

1                   **Hypothermic total liquid ventilation is highly protective through cerebral**  
2                   **hemodynamic preservation and sepsis-like mitigation**  
3                   **after asphyxial cardiac arrest**

4   Matthias Kohlhauer, DVM, MSc <sup>1,2,3</sup>, Fanny Lidouren BSc <sup>1,2,3</sup>, Isabelle Remy-Jouet, PhD <sup>4</sup>,  
5       Nicolas Mongardon, MD, MSc <sup>1,2,3</sup>, Clovis Adam, MD <sup>5</sup>, Patrick Bruneval, MD <sup>6</sup>,  
6       Hakim Hocini, PhD <sup>2,7,8</sup>, Yves Levy, MD, PhD <sup>2,7,8</sup>, Fabiola Blengio, BSc <sup>2,7,8</sup>,  
7       Pierre Carli, MD, PhD <sup>9</sup>, Benoit Vivien, MD, PhD <sup>9</sup>, Jean-Damien Ricard, MD, PhD <sup>10</sup>,  
8       Philippe Micheau, PhD <sup>11</sup>, Hervé Walti, MD, PhD <sup>11</sup>, Mathieu Nadeau, MSc <sup>11</sup>, Raymond  
9       Robert, PhD <sup>11</sup>, Vincent Richard, PhD <sup>4</sup>, Paul Mulder, PharmD, PhD <sup>4</sup>, David Maresca,  
10      PhD<sup>12</sup>, Charlie Demené, PhD <sup>12</sup>, Mathieu Pernot, PhD <sup>12</sup>, Mickael Tanter, PhD <sup>12</sup>,  
11      Bijan Ghaleh, MD, PhD <sup>1,2,3</sup>, Alain Berdeaux, MD, PhD <sup>1,2,3</sup>, Renaud Tissier, DVM, PhD <sup>1,2,3</sup>

12   <sup>1</sup> Inserm, U955, Equipe 03, F94000, Créteil, France

13   <sup>2</sup> Université Paris Est, UMR\_S955, UPEC, F-94000, Créteil, France

14   <sup>3</sup> Université Paris Est, Ecole Nationale Vétérinaire d'Alfort, F-94700, Maisons-Alfort,  
15   France

16   <sup>4</sup> Inserm, U1096, plate-forme BOSS, F-76183, Rouen, France

17   <sup>5</sup> Assistance Publique, Hôpitaux de Paris, Hôpital du Kremlin-Bicêtre, Service d'Anatomie  
18   Pathologique, Le Kremlin-Bicêtre, F-94270, France

19   <sup>6</sup> Inserm, U970, F-75005, Paris, France

20   <sup>7</sup> Inserm, U955, Equipe 16, F-94000, Créteil, France

21   <sup>8</sup> Vaccine research Institute, F-94000, Créteil, France

22   <sup>9</sup> SAMU de Paris, Département d'Anesthésie Réanimation, Hôpital Universitaire Necker-  
23   Enfants Malades, Université Paris Descartes – Paris V, F-75015, Paris, France

24   <sup>10</sup> Inserm, IAME, 1137, Univ Paris Diderot, Sorbonne Paris Cité, F-75018, Paris, and  
25   Assistance Publique - Hôpitaux de Paris, Hôpital Louis Mourier, Service de Réanimation  
26   Médico-chirurgicale, F-92700, Colombes, France

27   <sup>11</sup> Sherbrooke Departments of Mechanical Engineering and Physiology, University of  
28   Sherbrooke, QC, Canada

29   <sup>12</sup> Institut Langevin, CNRS UMR 7587, INSERM U979, ESPCI ParisTech, F-75005, Paris,  
30   France

31   **Institutions where the work was performed :** Affiliations 1-4; 7-8; 10

32   **Corresponding author:** Renaud Tissier

33   Inserm, Unité 955, Equipe 3

34   Université Paris Est, Ecole Nationale Vétérinaire d'Alfort

35   7 avenue du Général de Gaulle ; 94704 Maisons-Alfort cedex, France

36   Tel: +33.1.43.96.73.02; Fax: +33.1.43.96.73.99; E-mail: rtissier@vet-alfort.fr

37  
38   **Financial support:**

39   - Grant ABYSS- R12031JJ from the "Agence Nationale pour la Recherche" (Paris, France)

40   - Grant PSR-SIIRI-757 from the "Ministère du Développement économique, de  
41   l'Innovation et de l'Exportation" (QC, Canada)

42   - Grant from the Region Ile-de France (CORDDIM)

43   - Grant DBS20140930781 from the « Fondation pour la Recherche Médicale » (FRM)

44

45 **Abstract**

46 **Objective** - Total liquid ventilation (TLV) provides ultra-fast and potently neuro- and  
47 cardioprotective cooling after shockable cardiac arrest and myocardial infarction in  
48 animals. Our goal was to decipher the effect of hypothermic TLV on the systemic and  
49 cerebral response to asphyxial cardiac arrest using an original pressure- and volume-  
50 controlled ventilation strategy in rabbits.

51 **Design** - Randomized animal study.

52 **Setting** - Academic research laboratory.

53 **Subjects** - New Zealand Rabbits.

54 **Interventions** - Thirty-six rabbits were submitted to 13 min of asphyxia, leading to  
55 cardiac arrest. After resumption of spontaneous circulation, they underwent either  
56 normothermic life support (Control group, n=12) or hypothermia induced by either 30  
57 min of TLV (TLV group, n=12) or i.v. cold saline (CONV group, n=12).

58 **Measurements and Main Results** - Ultra-fast cooling with TLV (32°C within 5 min in the  
59 oesophagus) dramatically attenuated the post-cardiac arrest syndrome regarding  
60 survival, neurological dysfunction and histological lesions (brain, heart, kidney, liver,  
61 lungs). Final survival rate achieved 58% vs 0% and 8% in TLV, Control and CONV groups  
62 (p<0.05), respectively. This was accompanied by an early preservation of the blood  
63 brain barrier integrity and cerebral hemodynamics, as well as reduction in the  
64 immediate reactive oxygen species production in the brain, heart and kidney after  
65 cardiac arrest. Later on, TLV also mitigated the systemic inflammatory response through  
66 alteration of monocyte chemoattractant protein-1, interleukin-1 $\beta$  and interleukin-8  
67 transcripts levels as compared to Control. In the CONV group, cooling was achieved  
68 more slowly (32°C within 90-120 min in the oesophagus), providing none of the above-  
69 mentioned systemic or organ protection.

70 **Conclusions** - Ultra-fast cooling by TLV limits the post-cardiac arrest syndrome after  
71 asphyxial cardiac arrest in rabbits. This protection involves an early limitation in  
72 reactive oxidative species production, blood-brain barrier disruption and delayed  
73 preservation against the systemic inflammatory response.

74 **Key-words:** Cardiopulmonary resuscitation; Cerebral ischemia; Cardiac arrest;  
75 Hypothermia; Liquid ventilation; Asphyxia.

76 **Introduction**

77       Beyond neurological and hemodynamic disorders (1), multivisceral dysfunction and  
78 respiratory complications (2, 3) participate to the dramatic outcome of resuscitated  
79 patients after cardiac arrest. Temperature management has been proposed to improve  
80 this outcome (4, 5) but the ideal target temperature is still debated between 32-34°C  
81 (mild therapeutic hypothermia) or 36°C (6). This is in apparent contradiction with many  
82 animal studies clearly demonstrating potent benefits with therapeutic hypothermia at  
83 32-34°C (7-12). Such discrepancy could be a consequence of the differential ability to  
84 achieve rapid cooling in laboratory animals as compared to humans. Indeed, if rodents  
85 can be externally cooled within a couple of minutes, humans typically required couple of  
86 hours (13). This can in part explain the potent protection observed with intra-arrest  
87 experimental hypothermia in laboratory animals (7) as compared to the lack of benefit  
88 with pre-hospital cooling using current methods in the clinical arena (13). Thus, a key  
89 challenge is to determine whether it is possible to cool a human body as rapidly as in  
90 animals and to decipher the mechanisms supporting the benefit of such rapid cooling.  
91 Several techniques are currently proposed to achieve this goal including peritoneal  
92 lavage, (14) nasal evaporative cooling (15), partial (16) or total liquid ventilation (TLV)  
93 (8, 11, 12). The latter technique can use the lungs as a heat exchanger and provides  
94 rapid and systemic cooling independently of body weight (8, 17, 18). It can for example  
95 cool down the entire body at 32°C within 10-20 min in rabbits, lambs or swine (8, 17-  
96 19). After shockable cardiac arrest, hypothermic TLV improved survival (8, 17) as well  
97 as neurological (8), cardiac (17) and renal outcomes (20) in rabbits while conventional  
98 cooling was not protective (8, 17). Until now, the clinical translation of this concept was  
99 limited by the previous demonstration of lung injuries in early trials with partial liquid

100 ventilation in patients with acute respiratory distress syndrome (21). In contrast, recent  
101 experimental studies suggested that TLV could be better tolerated and beneficial in this  
102 context of respiratory care (22, 23). Here, we propose to use a new and original  
103 specifically dedicated liquid ventilator accurately controlling both tidal volume and  
104 pulmonary pressure (24, 25) in order to prevent lung trauma and to provide systemic  
105 and rapid hypothermia in the context of non-shockable cardiac arrest.

106 For these purposes, we investigated TLV in an experimental model of non-shockable  
107 and asphyxial cardiac arrest, as the effect of hypothermia is especially debated after  
108 non-shockable rhythm (26). Neurological, multivisceral and inflammatory outcomes  
109 were therefore assessed after 13 minutes of asphyxia in rabbits. The specific hypothesis  
110 was that hypothermic TLV could be highly neuroprotective through mitigation of early  
111 reperfusion alterations after cardiac arrest, *i.e.*, cerebral blood flow disturbances, blood  
112 brain barrier (BBB) permeability and reactive oxygen species (ROS) production.  
113 Importantly, the effects of TLV were compared to conventional cooling with external  
114 method and cold saline infusion.

115

116 **Materials and Methods**

117 Animal instrumentation and the ensuing experiments were conducted in accordance  
118 with French official regulations after approval by the local ethical committee  
119 (ComEth AnSES/ENVA/UPEC n°16).

120 *Animal preparation and experimental protocol*

121 Male New Zealand rabbits (2.5-3.0 kg) were anaesthetized using zolazepam,  
122 tiletamine and pentobarbital (all 20-30 mg/kg i.v.). After intubation and mechanical  
123 ventilation ( $FiO_2 = 30\%$ ), rabbits were paralyzed by cisatracurium besylate (0.2 mg/kg,  
124 i.v.). Asphyxial cardiac arrest was then induced by disconnecting the endotracheal tube  
125 from the ventilator during 13 min. Preliminary experiments demonstrated that cardiac  
126 arrest, *i.e.*, null cardiac output, was obtained within 4.5-5.5 min (data not shown). After  
127 13 min of asphyxia, animals were resuscitated using external cardiac massage (200  
128 compressions/min) and epinephrine administration (15  $\mu$ g/kg i.v.). After resumption of  
129 spontaneous circulation (ROSC), animals were randomly assigned to one experimental  
130 group (Control, CONV or TLV; Figure 1A). The administration of epinephrine was further  
131 permitted during 8 h (target mean blood pressure = 80 mmHg). The Control group did  
132 not receive any additional procedure and was maintained under normothermic  
133 condition by the use of thermal pads. In the CONV group, hypothermia was induced by  
134 conventional cooling through the intravenous administration of 30 ml/kg of cold saline  
135 (NaCl, 0.9%, 4°C) during the first 30 min after ROSC. It was combined with the  
136 application of cold blankets (0-4°C) upon the skin with no prior shaving. In the TLV  
137 group, ultra-fast cooling was induced by TLV started 5 min after ROSC. The lungs were  
138 filled by 13 ml/kg of perfluorooctane (F2 Chemicals, Preston, UK), with an initial  
139 temperature of 20°C and a progressive increase to 33°C. The liquid ventilator was  
140 initially set to a tidal volume of 10 ml/kg, a respiratory frequency of 8 cycle/min and a

141 positive end-expiratory pressure (PEEP) of 2 cmH<sub>2</sub>O, respectively (Figure 1B). We used  
142 a previously described algorithm with a volume- and pressure-controlled liquid  
143 ventilation mode monitoring PEEP and positive end-inspiratory pressure (PEIP) (Figure  
144 1C). Static lung compliance was calculated by dividing tidal volume by (PEIP-PEEP).  
145 After 30 min of TLV, animals were weaned from TLV by prolonged exhalation  
146 at -15 cmH<sub>2</sub>O. The liquid ventilator was then disconnected and animals were shifted to  
147 conventional mechanical ventilation. In the two hypothermic groups (CONV and TLV),  
148 the target temperature of 32°C was maintained by cold blankets until the 4<sup>th</sup> hour after  
149 ROSC. Animals were then slowly rewarmed with infrared lights and thermal pads during  
150 4 hours before weaning from conventional ventilation and awakening. Mechanical  
151 ventilation was continued until weaning from the mechanical ventilation and awakening  
152 of the animals. Rabbits were subsequently returned to cages for survival follow-up. They  
153 were housed in a closed cage enriched in O<sub>2</sub> for 24 hours. They received antibiotics  
154 (enrofloxacin, 5 mg/kg IM) and analgesics (buprenorphine, 30 µg/kg SC) every days for  
155 3 days.

#### 156 *Investigated parameters during the survival follow-up*

157 Throughout the protocol, we measured body temperatures, hemodynamics and  
158 biochemical parameters (Supplemental Method). In surviving animals, neurological  
159 dysfunction was blindly and daily evaluated using a clinical score previously validated in  
160 rabbits (0% [normal] - 100% [death]; Supplemental Table 1) (8, 17, 27). Survival was  
161 monitored during 3 days before euthanasia and organs sampling. In accordance with our  
162 ethical committee, animals eliciting a neurological dysfunction score above 80% at  
163 24 hours or 60% at 48 hours were prematurely euthanized. The heart, kidney, liver,  
164 lungs and brain were examined by histopathology and lesions were quantified using a 0-  
165 3 score system (0=normal; 3=very severe; ; Supplemental Tables 2 and 3), as previously

166 described (8, 17, 27). For lungs, two different score systems were used for infectious or  
167 cardiogenic congestive lesions, respectively. In the brain, the overall score was obtained  
168 by the average of the right and left cortex, hippocampus and cerebellum (8, 17, 27).

169 Blood was also sampled at different time points for quantification of mRNA  
170 expression of inflammation and/or hypoxia markers including interleukins (IL) 1 $\beta$ , 8  
171 and 10, interferon- $\gamma$  (IFN $\gamma$ ), tumor necrosis factor- $\alpha$  (TNF $\alpha$ ), hypoxia-inducible factor 1  
172 alpha (HIF1- $\alpha$ ) and heme oxygenase-1 (HO-1) as previously described (20)  
173 (Supplemental Table 4).

174 *Assessment of reactive oxygen species production, blood brain barrier integrity and*  
175 *cerebral blood volume*

176 Additional rabbits were submitted to the previously described procedure for early  
177 organ sampling and fixation, *i.e.*, 30 min after cardiac arrest. Brain cortex and  
178 hippocampus, heart, kidneys, lungs and liver were frozen in liquid nitrogen. ROS  
179 production was evaluated by electron paramagnetic resonance spectroscopy (detailed  
180 protocol in supplemental Method) as previously described (28-30). Other rabbits were  
181 submitted to the same procedures of cardiac arrest for BBB integrity evaluation using  
182 the Evans Blue Dye leakage method (Supplemental Method). In a last set of experiments,  
183 cerebral hemodynamics was assessed during cardiac arrest and after resuscitation using  
184 ultrafast ultrasound Doppler imaging, as previously described (31, 32).

185 *Statistical analysis*

186 Data were expressed as mean $\pm$ SEM. Hemodynamic and biochemical parameters  
187 were compared between different groups using a 2-way ANOVA for repeated measures.  
188 If necessary, post-hoc analyses were performed at each time point using a Student t-test  
189 with Bonferroni correction. Values were not compared between the different time  
190 points to avoid multiple comparisons. Neurological dysfunction and histological scores

191 were compared between groups using a Mann-Whitney nonparametric test. Survival  
192 curves were obtained with a Kaplan-Meier analysis and compared between groups with  
193 a log-rank test. Significant differences were determined at  $p \leq 0.05$ .

194

195



196 **Results**

197 *Total liquid ventilation can be instituted safely after resuscitation*

198 As shown in Table 1, 12 animals were successfully resuscitated in each group with  
199 similar times to ROSC. During TLV, tidal volume and PEEP values averaged  $8.9 \pm 0.3$   
200 ml/kg and  $2.1 \pm 0.2$  cmH<sub>2</sub>O in the corresponding group. This led to low PEIP values ( $11.4$   
201  $\pm 0.3$  cmH<sub>2</sub>O) which were well tolerated regarding gas exchanges (Table 2) and static  
202 lung compliance (Figure 1D) in the TLV group. The compliance impairment after cardiac  
203 massage was even partially reversed after weaning in the TLV group as compared to  
204 Control and CONV groups, respectively.

205 *TLV induces rapid cooling without hemodynamic disorders*

206 In the TLV group, body temperatures decreased to 32°C within 5-15 min as  
207 illustrated in Figure 2. In comparison, conventional cooling required 90-120 min to  
208 achieve the same target (CONV group). As shown in Table 1, heart rate decreased  
209 throughout hypothermia in the CONV and TLV groups while mean arterial pressure,  
210 blood gases and biochemical parameters were not different between groups. The  
211 amount of epinephrine administered to prevent hypotension was however significantly  
212 lower in the TLV group as compared to Control.

213 *TLV offers neurological and lung protection and improves survival*

214 As illustrated in Figure 3A, ultra-fast cooling by TLV was associated with a dramatic  
215 improvement of the neurological status as compared to Control and CONV groups. For  
216 example, neurological dysfunction score was 48% at day 1 in the TLV group as  
217 compared to 89 and 90% in the CONV and Control groups (median values), respectively.  
218 This reduction was significant when all animals were taken into account (including dead  
219 animals with 100% score) but also when dead animals were excluded from this analysis  
220 (scores of alive animals only). The final survival rate achieved 58% in the TLV group vs

221 0% and 8% in the Control and CONV groups ( $p < 0.05$ ; Figure 3B), respectively. The  
222 neuroprotective effect of TLV was associated with a significant limitation of brain  
223 ischemic lesions as compared to the Control and CONV groups (Figure 4 and  
224 Supplemental Figure 1, Panels A-D).

225 Beyond cerebral lesions, lung congestive and infectious complications were the  
226 most severe consequences of cardiac arrest after pathological examinations (Figure 4).  
227 Congestive lesions were attenuated in TLV (Supplemental Figure 1, Panels E-F) vs  
228 Control groups (Supplemental Figure 1, Panel G). Conversely, they tended to be  
229 aggravated in the CONV group (Supplemental Figure 1, Panel H). A trend toward  
230 reduced pulmonary infection was also observed in the TLV vs Control and CONV groups  
231 (Figure 4).

#### 232 *TLV limits early blood brain barrier disruption and cerebral hyperemia*

233 We then hypothesized that the multi-organ protection afforded by TLV could be  
234 linked to mitigation of early reperfusion injury. For this purpose, we investigated ROS  
235 production in additional organ samples withdrawn 30 min after cardiac arrest in rabbits  
236 ( $n=8$  in each group). As illustrated in Figure 5, this production was decreased in the  
237 brain cortex, heart and kidney in the TLV group as compared to Control ( $p < 0.05$ ). A non-  
238 significant tendency was also observed in the hippocampus and liver. Interestingly, slow  
239 cooling did not reduce ROS production in the CONV group. We then hypothesized that  
240 the decrease in ROS production could be a major trigger of neuroprotection through  
241 BBB integrity and cerebral hemodynamics protection. Indeed, BBB disruption was  
242 observed very early after cardiac arrest through Evans blue dye leakage (Figure 6A-B,  
243  $n=4$  in each group). TLV significantly limited this disruption as compared to Control and  
244 CONV groups when assessed 30 min after cardiac arrest ( $n=4$  in each group). In order to

245 corroborate this vascular effect, cerebral blood volume was further evaluated by ultra-  
246 fast ultrasound Doppler in other rabbits (Figure 6C). As shown in Figure 6D, cerebral  
247 hyperemia lasted approximately 30 min in the Control group (n=2) and was attenuated  
248 in the TLV group (n=2).

249 *TLV mitigates the systemic responses to cardiac arrest*

250 In order to assess the subsequent systemic responses to cardiac arrest, we then  
251 investigated the effect of TLV on the sepsis-like syndrome (2). The severity of hypoxic  
252 injury was evidenced by a potent up-regulation of HIF1- $\alpha$  and HO-1 (Figure 7A).  
253 Interestingly, early cooling with TLV amplified HO-1 up-regulation from the 8<sup>th</sup> hour  
254 after cardiac arrest. As illustrated in Figure 7B, an early pro-inflammatory response was  
255 also observed through an increase in IL-1 $\beta$ , IL-8 and MCP-1 transcripts. This response  
256 was significantly reduced by TLV vs Control at the 8<sup>th</sup> hour after cardiac arrest. The anti-  
257 inflammatory IL-10 cytokine was simultaneously up-regulated in the Control group and  
258 tended to be attenuated by TLV at the 24<sup>th</sup> hour after cardiac arrest. These data suggest  
259 that early cooling with TLV mitigates both the early pro-inflammatory and delayed anti-  
260 inflammatory responses induced by cardiac arrest. This was also associated with a  
261 down-regulation of IFN $\gamma$  and TNF $\alpha$  at the 24<sup>th</sup> hour after cardiac arrest in all groups.  
262

263 **Discussion**

264 In the present study, ultra-fast cooling with TLV potently limited the post-cardiac  
265 arrest syndrome after non-shockable and asphyxial cardiac arrest in rabbits while  
266 conventional cooling was inefficient. The protection was initiated as early as the first  
267 minutes following resuscitation. It was associated with inhibition of ROS production,  
268 limitation of BBB disruption and prevention of cerebral hyperemia. An ultimate  
269 attenuation of the so-called “sepsis-like” syndrome was also observed, showing that  
270 short, rapid and systemic hypothermia could attenuate the entire systemic response to  
271 anoxia.

272 Importantly, our experimental conditions of cardiac arrest were particularly severe  
273 as mortality and neurological dysfunctions were maximal in the Control group.  
274 Conventional cooling was even unable to provide any benefit as compared to TLV,  
275 supporting the concept that the rapidity of cooling plays a decisive protective role in  
276 such very severe conditions. Previous studies also demonstrated that immediate  
277 hypothermia was dramatically protective in mice after 8 min of asystole but not after a  
278 20 min delay after resuscitation (7). Interestingly, the benefit of conventional  
279 hypothermia is also highly challenged in humans after non-shockable cardiac arrest  
280 (26).

281 From a biochemical point of view, the severity of the ischemic injury is associated  
282 with a potent up-regulation of HIF-1 $\alpha$  in all groups in the present study. This  
283 transcription factor is well known to be enhanced during hypoxia (33) and could lead to  
284 various consequences such as vascular endothelium growth factor secretion, apoptosis  
285 or oxidative stress (34). Its upregulation could be linked to the activation of HO-1  
286 protective pathway (35) which occurred earlier in the TLV group as compared to  
287 Control or CONV groups. Such an earlier activation could promote ubiquitous benefits

288 regarding ROS production and inflammation in the TLV group (36). In addition,  
289 ultra-fast cooling with TLV potentially limited multi-organ ROS production as soon as 30  
290 min after CPR initiation. As this was observed not only in the brain but also in the heart  
291 and kidney, it emphasizes the importance of systemic hypothermia by TLV.

292 In order to further investigate the neuroprotective effect of TLV, we also  
293 investigated BBB permeability and showed very rapid impairment in Control conditions,  
294 *i.e.*, 30 min after cardiac arrest. This impairment was totally prevented by TLV, in  
295 agreement with the previously shown limitation in ROS production and reduced  
296 hyperemia observed with ultrafast ultrasound imaging. The lack of benefit of  
297 conventional cooling in these conditions also suggests that hypothermia should be  
298 achieved at least before 90 min after cardiac arrest to efficiently inhibit the triggering  
299 events of neurological injury.

300 Since one major interest of TLV is to provide rapid and systemic cooling, we also  
301 investigated the systemic responses to cardiac arrest and the “sepsis-like” biochemical  
302 disorders (2). Importantly, the balance between the early pro-inflammatory and the  
303 later anti-inflammatory responses was modified by TLV but not through conventional  
304 cooling. This is consistent with previous studies showing a lack of benefit with delayed  
305 hypothermia in rats submitted to asphyxial cardiac arrest (37). The benefit of TLV  
306 persisted far into the rewarming phase (*i.e.*, 8 h after cardiac arrest), demonstrating that  
307 mitigation of early resuscitation disorders (*e.g.*, ROS generation) resulted in delayed  
308 benefits during the entire post-cardiac arrest syndrome. The alterations in MCP-1 levels  
309 are especially of interest in this regard, as it is associated with brain injury during  
310 stroke (38). Conversely, IFN $\gamma$  and TNF $\alpha$  were not really modified in our conditions,  
311 which is likely related to a selective regional activation and/or different time-courses of  
312 activation (39).

313 In agreement with our previous studies (8, 17, 20), we confirmed here that TLV was  
314 well tolerated regarding lung function and histology. For this purpose, we used an  
315 original and advanced liquid ventilator that accurately controls both liquid filling  
316 pressures and volumes within the lungs (25). Beyond its capacity to induce an ultrafast  
317 and systemic hypothermia, such liquid ventilator was also able to preserve lung function  
318 and ultrastructure at difference with conventional hypothermia with cold fluid which  
319 promoted lung congestion (13). Alteration in lung static compliance after cardiac  
320 massage was even reversed by TLV, several hours after cardiac arrest as compared to  
321 others groups. This impairment in Control conditions could be consequence of  
322 pulmonary ischemia-perfusion and/or direct effect of the cardiac massage. TLV and  
323 perfluorocarbons may directly and independently reduce the congestive lesions and  
324 pulmonary infection. This shows that TLV could be well tolerated with such  
325 sophisticated and dedicated liquid ventilator, as compared to previous studies using  
326 partial liquid ventilation which were associated with lung injury (21). This new  
327 ventilator could therefore open promising perspectives for the applications of TLV and  
328 for the future management of cardiac arrest.

329 Our study presents however several limitations. As previously discussed, we only  
330 investigated some time-points for biochemical, ROS and imaging studies. Other  
331 experiments with additional time-points could be highly relevant to better understand  
332 the kinetic of alterations. It could also be relevant to investigate normothermic TLV or  
333 hypothermic TLV with a different schedule of institution (e.g., delayed initiation and/or  
334 duration). However, normothermic TLV did not provide any benefit after shockable  
335 arrest (8), supporting that TLV is only protective through its cooling properties. Longer  
336 episode of hypothermia could also be tested, as currently done in the clinical setting.  
337 However, if hypothermia needs to be prolonged to provide benefits after experimental

338 stroke (>12h) (40), it is well known that shorter episodes can be maximally protective  
339 after cardiac arrest (7, 41).

340 In conclusion, ultra-fast cooling with TLV limits the post-cardiac arrest syndrome  
341 after asphyxial cardiac arrest in rabbits with potent neurological and survival benefits.  
342 This protection involves an early and global limitation of ROS production, a rapid BBB  
343 preservation and an ultimate mitigation of the systemic inflammatory response. This  
344 was achieved using a “latest-generation” of liquid ventilator providing TLV safely and  
345 using the lungs as a unique medium for therapeutic hypothermia

346

347 **References**

- 348
- 349 1. Tian J, Kaufman DA, Zarich S, et al. Outcomes of critically ill patients who received  
350 cardiopulmonary resuscitation. *Am J Respir Crit Care Med* 2010;182:501-506.
- 351 2. Adrie C, Laurent I, Monchi M, et al. Postresuscitation disease after cardiac arrest:  
352 a sepsis-like syndrome? *Curr Opin Crit Care* 2004;10:208-212.
- 353 3. Perbet S, Mongardon N, Dumas F, et al. Early-onset pneumonia after cardiac  
354 arrest: characteristics, risk factors and influence on prognosis. *Am J Respir Crit Care Med*  
355 2011;184:1048-1054.
- 356 4. The Hypothermia After Cardiac Arrest Study Group. Mild therapeutic  
357 hypothermia to improve the neurologic outcome after cardiac arrest. *N Engl J Med*  
358 2002;346:549-556.
- 359 5. Bernard SA, Gray TW, Buist MD, et al. Treatment of comatose survivors of out-of-  
360 hospital cardiac arrest with induced hypothermia. *N Engl J Med* 2002;346:557-563.
- 361 6. Nielsen N, Wetterslev J, Cronberg T, et al. Targeted Temperature Management at  
362 33°C versus 36°C after Cardiac Arrest. *N Engl J Med* 2013;369:2197-2206.
- 363 7. Abella BS, Zhao D, Alvarado J, et al. Intra-arrest cooling improves outcomes in a  
364 murine cardiac arrest model. *Circulation* 2004;109:2786-2791.
- 365 8. Chenoune M, Lidouren F, Adam C, et al. Ultrafast and whole-body cooling with  
366 total liquid ventilation induces favorable neurological and cardiac outcomes after  
367 cardiac arrest in rabbits. *Circulation* 2011;124:901-911, 901-907.
- 368 9. Colbourne F, Corbett D. Delayed postischemic hypothermia: a six month survival  
369 study using behavioral and histological assessments of neuroprotection. *J Neurosci*  
370 1995;15:7250-7260.



- 371 10. Nozari A, Safar P, Stezoski SW, et al. Critical time window for intra-arrest cooling  
372 with cold saline flush in a dog model of cardiopulmonary resuscitation. *Circulation*  
373 2006;113:2690-2696.
- 374 11. Riter HG, Brooks LA, Pretorius AM, et al. Intra-arrest hypothermia: both cold  
375 liquid ventilation with perfluorocarbons and cold intravenous saline rapidly achieve  
376 hypothermia, but only cold liquid ventilation improves resumption of spontaneous  
377 circulation. *Resuscitation* 2009;80:561-566.
- 378 12. Staffey KS, Dendi R, Brooks LA, et al. Liquid ventilation with perfluorocarbons  
379 facilitates resumption of spontaneous circulation in a swine cardiac arrest model.  
380 *Resuscitation* 2008;78:77-84.
- 381 13. Kim F, Nichol G, Maynard C, et al. Effect of Prehospital Induction of Mild  
382 Hypothermia on Survival and Neurological Status Among Adults With Cardiac Arrest: A  
383 Randomized Clinical Trial. *Jama* 2013;311:45-52.
- 384 14. de Waard MC, Biermann H, Brinckman SL, et al. Automated peritoneal lavage: an  
385 extremely rapid and safe way to induce hypothermia in post-resuscitation patients. *Crit*  
386 *Care* 2013;17:R31.
- 387 15. Castren M, Nordberg P, Svensson L, et al. Intra-arrest transnasal evaporative  
388 cooling: a randomized, prehospital, multicenter study (PRINCE: Pre-ROSC IntraNasal  
389 Cooling Effectiveness). *Circulation* 2010;122:729-736.
- 390 16. Yang SS, Jeng MJ, McShane R, et al. Cold perfluorochemical-induced hypothermia  
391 protects lung integrity in normal rabbits. *Biol Neonate* 2005;87:60-65.
- 392 17. Darbera L, Chenoune M, Lidouren F, et al. Hypothermic Liquid Ventilation  
393 Prevents Early Hemodynamic Dysfunction and Cardiovascular Mortality After Coronary  
394 Artery Occlusion Complicated by Cardiac Arrest in Rabbits. *Crit Care Med* 2013;41:e457-  
395 465.

- 396 18. Nadeau M, Micheau P, Robert R, et al. Control of rapid hypothermia induction by  
397 total liquid ventilation : Preliminary results. Conf Proc IEEE Eng Med Biol Soc  
398 2013;2013:3757-3760.
- 399 19. Tissier R, Lidouren F, Hutin A, et al. Total liquid ventilation offers ultra-fast and  
400 whole-body cooling in large animals [abstract]. Circulation 2014.
- 401 20. Tissier R, Giraud S, Quellard N, et al. Kidney Protection by Hypothermic Total  
402 Liquid Ventilation after Cardiac Arrest in Rabbits. Anesthesiology 2014;120:861-869.
- 403 21. Kacmarek RM, Wiedemann HP, Lavin PT, et al. Partial liquid ventilation in adult  
404 patients with acute respiratory distress syndrome. Am J Respir Crit Care Med  
405 2006;173:882-889.
- 406 22. Wolfson MR, Hirschl RB, Jackson JC, et al. Multicenter comparative study of  
407 conventional mechanical gas ventilation to tidal liquid ventilation in oleic acid injured  
408 sheep. Asaio J 2008;54:256-269.
- 409 23. Pohlmann JR, Brant DO, Daul MA, et al. Total liquid ventilation provides superior  
410 respiratory support to conventional mechanical ventilation in a large animal model of  
411 severe respiratory failure. Asaio J 2011;57:1-8.
- 412 24. Avoine O, Bosse D, Beaudry B, et al. Total liquid ventilation efficacy in an ovine  
413 model of severe meconium aspiration syndrome. Crit Care Med 2011;39:1097-1103.
- 414 25. Robert R, Micheau P, Avoine O, et al. A regulator for pressure-controlled total-  
415 liquid ventilation. IEEE Trans Biomed Eng 2009;57:2267-2276.
- 416 26. Dumas F, Grimaldi D, Zuber B, et al. Is hypothermia after cardiac arrest effective  
417 in both shockable and nonshockable patients?: insights from a large registry. Circulation  
418 2011;123:877-886.
- 419 27. Baker AJ, Zornow MH, Grafe MR, et al. Hypothermia prevents ischemia-induced  
420 increases in hippocampal glycine concentrations in rabbits. Stroke 1991;22:666-673.

- 421 28. Favre J, Gao J, Zhang AD, et al. Coronary endothelial dysfunction after  
422 cardiomyocyte-specific mineralocorticoid receptor overexpression. *Am J Physiol Heart*  
423 *Circ Physiol* 2011;300:H2035-2043.
- 424 29. Bellien J, Iacob M, Remy-Jouet I, et al. Epoxyeicosatrienoic acids contribute with  
425 altered nitric oxide and endothelin-1 pathways to conduit artery endothelial dysfunction  
426 in essential hypertension. *Circulation* 2012;125:1266-1275.
- 427 30. Montaigne D, Marechal X, Coisne A, et al. Myocardial contractile dysfunction is  
428 associated with impaired mitochondrial function and dynamics in type 2 diabetic but  
429 not in obese patients. *Circulation* 2014;130:554-564.
- 430 31. Demene C, Pernot M, Biran V, et al. Ultrafast Doppler reveals the mapping of  
431 cerebral vascular resistivity in neonates. *J Cereb Blood Flow Metab* 2014;34:1009-1017.
- 432 32. Tanter M, Fink M. Ultrafast imaging in biomedical ultrasound. *IEEE Trans*  
433 *Ultrason Ferroelectr Freq Control* 2013;61:102-119.
- 434 33. Land SC, Tee AR. Hypoxia-inducible factor 1alpha is regulated by the mammalian  
435 target of rapamycin (mTOR) via an mTOR signaling motif. *J Biol Chem* 2007;282:20534-  
436 20543.
- 437 34. Benarroch EE. Hypoxia-induced mediators and neurologic disease. *Neurology*  
438 2009;73:560-565.
- 439 35. Oh GS, Pae HO, Lee BS, et al. Hydrogen sulfide inhibits nitric oxide production and  
440 nuclear factor-kappaB via heme oxygenase-1 expression in RAW264.7 macrophages  
441 stimulated with lipopolysaccharide. *Free Radic Biol Med* 2006;41:106-119.
- 442 36. Yao C, Wei G, Lu XC, et al. Selective brain cooling in rats ameliorates intracerebral  
443 hemorrhage and edema caused by penetrating brain injury: possible involvement of  
444 heme oxygenase-1 expression. *J Neurotrauma* 2011;28:1237-1245.

- 445 37. Callaway CW, Rittenberger JC, Logue ES, et al. Hypothermia after cardiac arrest  
446 does not alter serum inflammatory markers. *Crit Care Med* 2008;36:2607-2612.
- 447 38. Losy J, Zaremba J. Monocyte chemoattractant protein-1 is increased in the  
448 cerebrospinal fluid of patients with ischemic stroke. *Stroke* 2001;32:2695-2696.
- 449 39. Stoppe C, Fries M, Rossaint R, et al. Blood levels of macrophage migration  
450 inhibitory factor after successful resuscitation from cardiac arrest. *PLoS One*  
451 2012;7:e33512.
- 452 40. Clark DL, Penner M, Orellana-Jordan IM, et al. Comparison of 12, 24 and 48 h of  
453 systemic hypothermia on outcome after permanent focal ischemia in rat. *Exp Neurol*  
454 2008;212:386-392.
- 455 41. Ye S, Weng Y, Sun S, et al. Comparison of the durations of mild therapeutic  
456 hypothermia on outcome after cardiopulmonary resuscitation in the rat. *Circulation*  
457 2012;125:123-129.

458  
459  
460

461 **Legend of Figures**

462

463 **Figure 1: Experimental protocol and design of the liquid ventilator**

464 *Panel A:* Experimental protocol.

465 *Panel B:* Schematic representation and picture of the liquid ventilator.

466 *Panel C:* Typical waveforms of airway pressures and liquid flows during total liquid  
467 ventilation.

468 *Panel D:* Lung compliance at baseline and after cardiac arrest in the different groups.

469 *CONV group; CPR, Cardio pulmonary resuscitation; PTUh, programmable thermic unit of*  
470 *hypothermia; TLV, Total Liquid Ventilation; \*,  $p < 0.05$  vs Control; †,  $p < 0.05$  vs CONV.*

471

472 **Figure 2:** Tympanic, oesophageal and rectal temperatures in the different groups.

473 *CONV, Conventional cooling; TLV, Total Liquid Ventilation; \*,  $p < 0.05$  vs Control; †,  $p < 0.05$*   
474 *vs CONV.*

475

476 **Figure 3: Neurological outcome and survival**

477 *Panel A:* Neurological dysfunction scores at days 1 and 3 following resuscitation. Open  
478 circles represent individual scores and thick lines represent the median value of the  
479 corresponding group.

480 *Panel B:* Kaplan-Meyer curves of survival in the different groups.

481 *CONV, Conventional cooling; TLV, Total Liquid Ventilation; \*,  $p < 0.05$  vs Control; †,  $p < 0.05$*   
482 *vs CONV.*

483

484

485 **Figure 4: Lesional scores of the different organs in the different groups**

486 *Open circles represent individual scores and thick lines represent the median value of the*  
487 *corresponding group. CONV, Conventional cooling group; TLV, Total liquid ventilation; \*,*  
488 *p<0.05 vs Control; †, p<0.05 vs CONV.*

489

490 **Figure 5: Reactive oxygen species production**

491 The reactive oxygen species production was assessed in the brain cortex, hippocampus,  
492 heart, kidney, lungs and liver at t=30 min after cardiac arrest (n=8 in each group) by  
493 electron paramagnetic resonance spectroscopy (EPR). Data are expressed in arbitrary  
494 unit per gram of protein per minute.

495 *CONV, conventional cooling; TLV, total liquid ventilation; ROS, reactive oxygen species;*

496 *\*, p<0.05 vs control; †, p<0.05 vs CONV.*

497

498 **Figure 6: Assessment of blood brain barrier integrity and cerebral blood volume**  
499 **after cardiac arrest**

500 *Panel A:* Blood brain barrier permeability assessed by cerebral Evans blue dye  
501 concentration. Evans blue was distributed in the cerebral tissue through vascular  
502 leakage after *in vivo* administration at t=30 min after cardiac arrest (n=4 in each group).

503 *Panel B:* Typical pictures of brain slices in the different groups. Blue areas represent  
504 Evans blue dye vascular leakage.

505 *Panel C:* Ultra-fast ultrasound Doppler imaging after cardiac arrest. The echographic  
506 frontal views show the visual repartition of cerebral blood volume at the maximum  
507 intensity in representative rabbits of the Control and TLV groups. The corresponding  
508 hippocampus and cortical blood volumes were calculated in one control and one TLV  
509 rabbit.

510 Panel D: Overall cortical blood volume from Ultra-fast ultrasound Doppler imaging in  
511 one control and one TLV rabbits.

512 *CONV, conventional cooling; CPR, Cardio pulmonary resuscitation; TLV, total liquid*  
513 *ventilation; \*,  $p < 0.05$  vs control; †,  $p < 0.05$  vs CONV; A.U., arbitrary unit.*

514

515 **Figure 7: Blood transcriptomic profiles determined by quantitative real-time PCR**

516 *Panel A: Transcript levels of hypoxia pathway.*

517 *Panel B: Transcripts levels of blood immunity and inflammation markers.*

518 *Data are expressed as relative fold change as compared to baseline, i.e., prior to cardiac*

519 *arrest. CONV, conventional cooling; HIF1- $\alpha$ , hypoxia-inducible factor 1 alpha; HO-1, heme*

520 *oxygenase-1; IFN $\gamma$ , interferon- $\gamma$ ; IL, interleukin; MCP-1, monocyte chemoattractant*

521 *protein-1; TLR, toll-like receptor; TLV, total liquid ventilation; TNF  $\alpha$ , tumor necrosis*

522 *factor- $\alpha$ ; \*,  $p < 0.05$  vs Control.*

**Table 1:** Resuscitation parameters

	Control	CONV	TLV
<b><i>Body weight (kg)</i></b>	2.8±0.1	2.7±0.1	2.7±0.1
<b><i>Time to systolic blood pressure &lt; 40 mmHg during asphyxia (min)</i></b>	4.7±0.3	5.2±0.2	5.2±0.1
<b><i>Time to ROSC during cardiopulmonary resuscitation (min)</i></b>	1.5±0.3	1.5±0.3	1.5±0.2
<b><i>Total amount of epinephrine (µg/kg)</i></b>	164±22	133±23	101±11 <sup>a</sup>

CONV, Conventional cooling; TLV, Total liquid ventilation; ROSC, resumption of spontaneous circulation;

<sup>a</sup>,  $p < 0.05$  vs Control.



**Table 2:** Hemodynamic and biochemical parameters

	Baseline	After cardiac arrest			
		30 min	180 min	360 min	Day 1
<b>Number of rabbits</b>					
Control	12	12	12	12	8
CONV	12	12	12	12	8
TLV	12	12	12	12	12
<b>Mean arterial blood pressure (mmHg)</b>					
Control	69 ± 3	83 ± 2	82 ± 3	77 ± 3	96 ± 5
CONV	78 ± 2	79 ± 2	83 ± 3	83 ± 3	82 ± 11
TLV	72 ± 4	81 ± 4	83 ± 3	79 ± 2	86 ± 8
<b>Heart rate (beats/min)</b>					
Control	241 ± 9	198 ± 3.0	202 ± 10.5	228 ± 9.1	265 ± 23.3
CONV	260 ± 12	209 ± 11	149 ± 5 <sup>a</sup>	201 ± 8.4	224 ± 28.2
TLV	238 ± 13	124 ± 6 <sup>ab</sup>	148 ± 6 <sup>a</sup>	195 ± 6.8	237 ± 27.8
<b>Arterial pCO<sub>2</sub> (Torr)</b>					
Control	47 ± 3	58 ± 3	-	46 ± 2	30 ± 3
CONV	51 ± 3	65 ± 4	-	43 ± 1	44 ± 11
TLV	46 ± 3	65 ± 3	-	39 ± 2	55 ± 4
<b>Arterial pO<sub>2</sub> (Torr)</b>					
Control	172 ± 7	109 ± 13	-	146 ± 8	82 ± 9
CONV	148 ± 10	84 ± 4	-	154 ± 15	67 ± 12
TLV	168 ± 8	123 ± 15	-	170 ± 7	71 ± 6
<b>Arterial pH</b>					
Control	7.42 ± 0.04	7.14 ± 0.02	-	7.34 ± 0.03	7.39 ± 0.03
CONV	7.36 ± 0.02	7.07 ± 0.03	-	7.28 ± 0.02	7.36 ± 0.09
TLV	7.42 ± 0.02	7.08 ± 0.02	-	7.28 ± 0.03	7.31 ± 0.02
<b>HCO<sub>3</sub><sup>-</sup> blood levels (mmol/L)</b>					
Control	28 ± 1	19 ± 2	-	23 ± 1	18 ± 3
CONV	29 ± 1	20 ± 1	-	21 ± 1	22 ± 1
TLV	28 ± 1	21 ± 1	-	19 ± 1	26 ± 11
<b>Glucose blood levels (mg/dL)</b>					
Control	1.8 ± 0.1	4.4 ± 0.2	-	1.8 ± 0.3	1.5 ± 0.3
CONV	2.2 ± 0.2	4.2 ± 0.3	-	2.5 ± 0.4	1.6 ± 0.2
TLV	1.9 ± 0.1	3.7 ± 0.4	-	2.7 ± 0.2	1.6 ± 0.1
<b>Creatinine blood levels (mg/dL)</b>					
Control	77 ± 7	75 ± 7	-	81 ± 5	145 ± 35
CONV	67 ± 5	58 ± 4	-	66 ± 6	136 ± 15
TLV	73 ± 5	86 ± 5	-	94 ± 6	107 ± 8
<b>Alanine transaminase (UI/L)</b>					
Control	46 ± 3	-	128 ± 21	129 ± 18	142 ± 23
CONV	55 ± 9	-	129 ± 16	111 ± 14	157 ± 40
TLV	45 ± 7	-	135 ± 19	144 ± 23	124 ± 20
<b>Lactate dehydrogenase (UI/L)</b>					
Control	306 ± 37	-	885 ± 217	460 ± 72	498 ± 128
CONV	341 ± 31	-	923 ± 180	602 ± 97	542 ± 210
TLV	365 ± 38	-	808 ± 136	585 ± 134	516 ± 64

CONV, Conventional cooling; TLV, Total liquid ventilation ; <sup>a</sup>, p<0.05 vs Control; <sup>b</sup>, p<0.05 vs CONV.

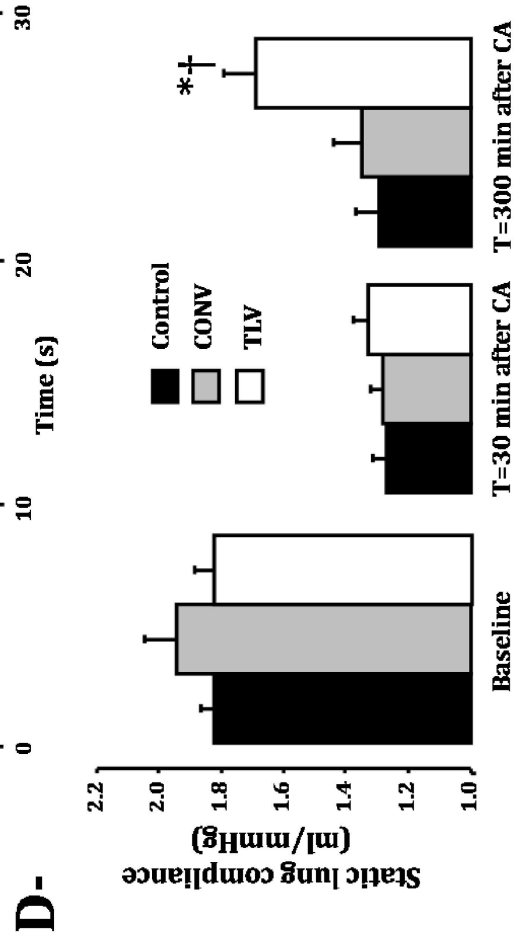
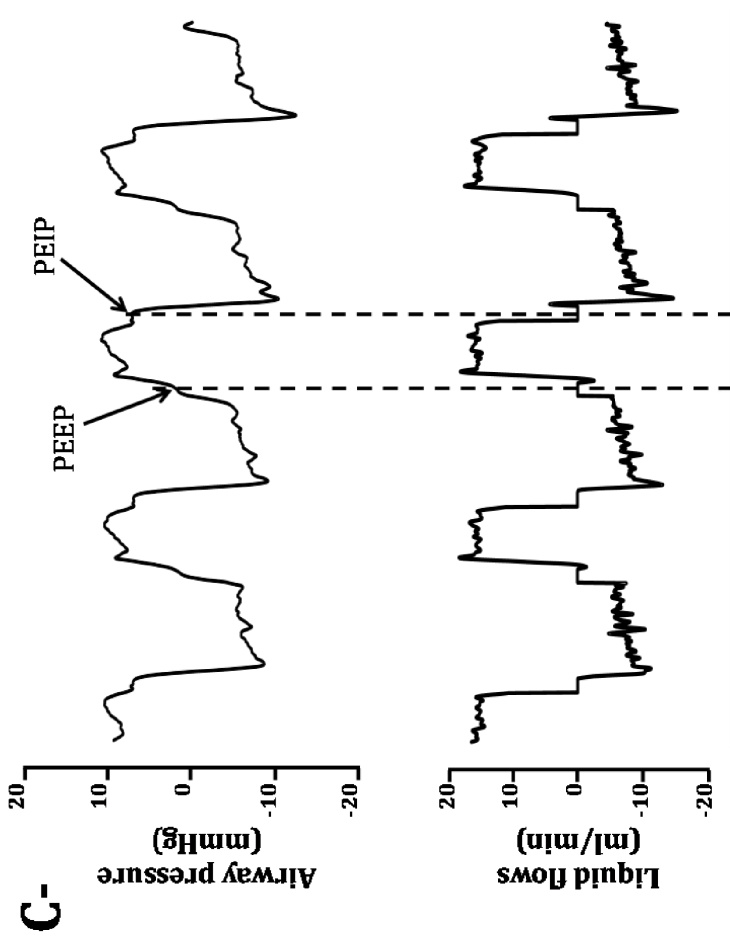
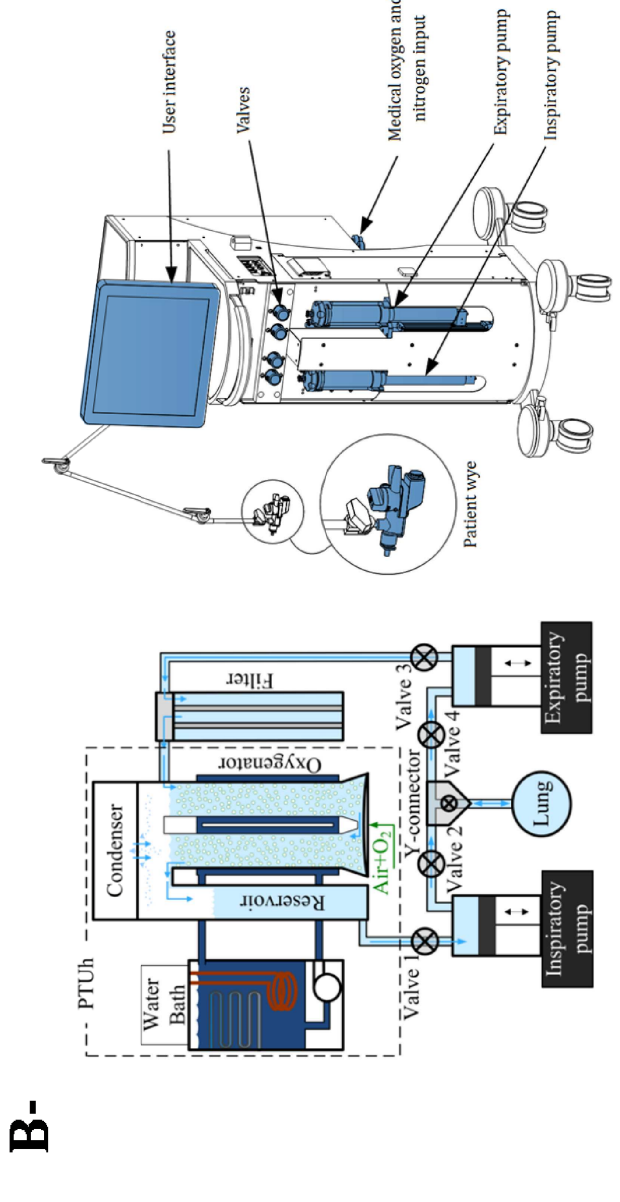
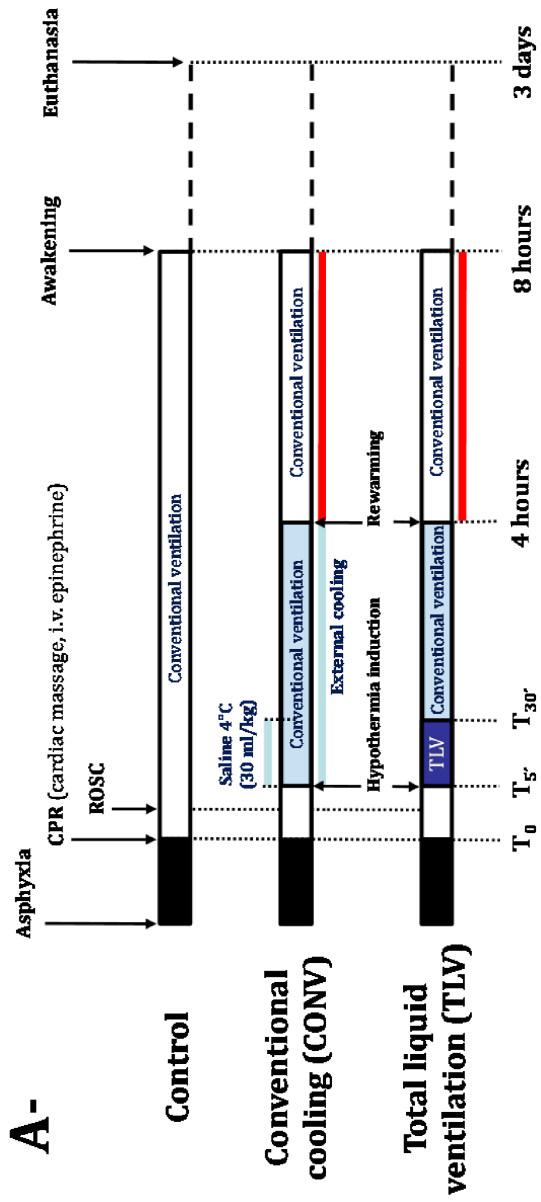

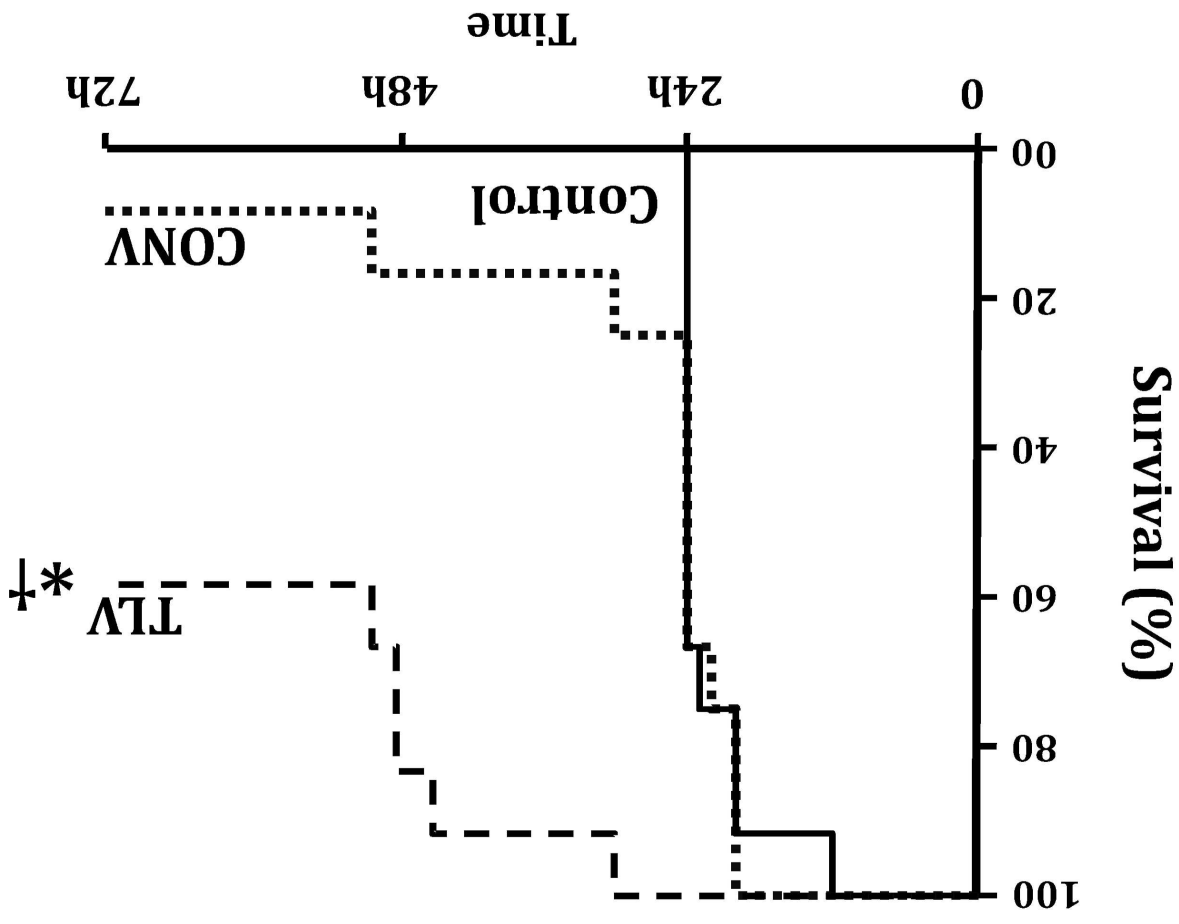
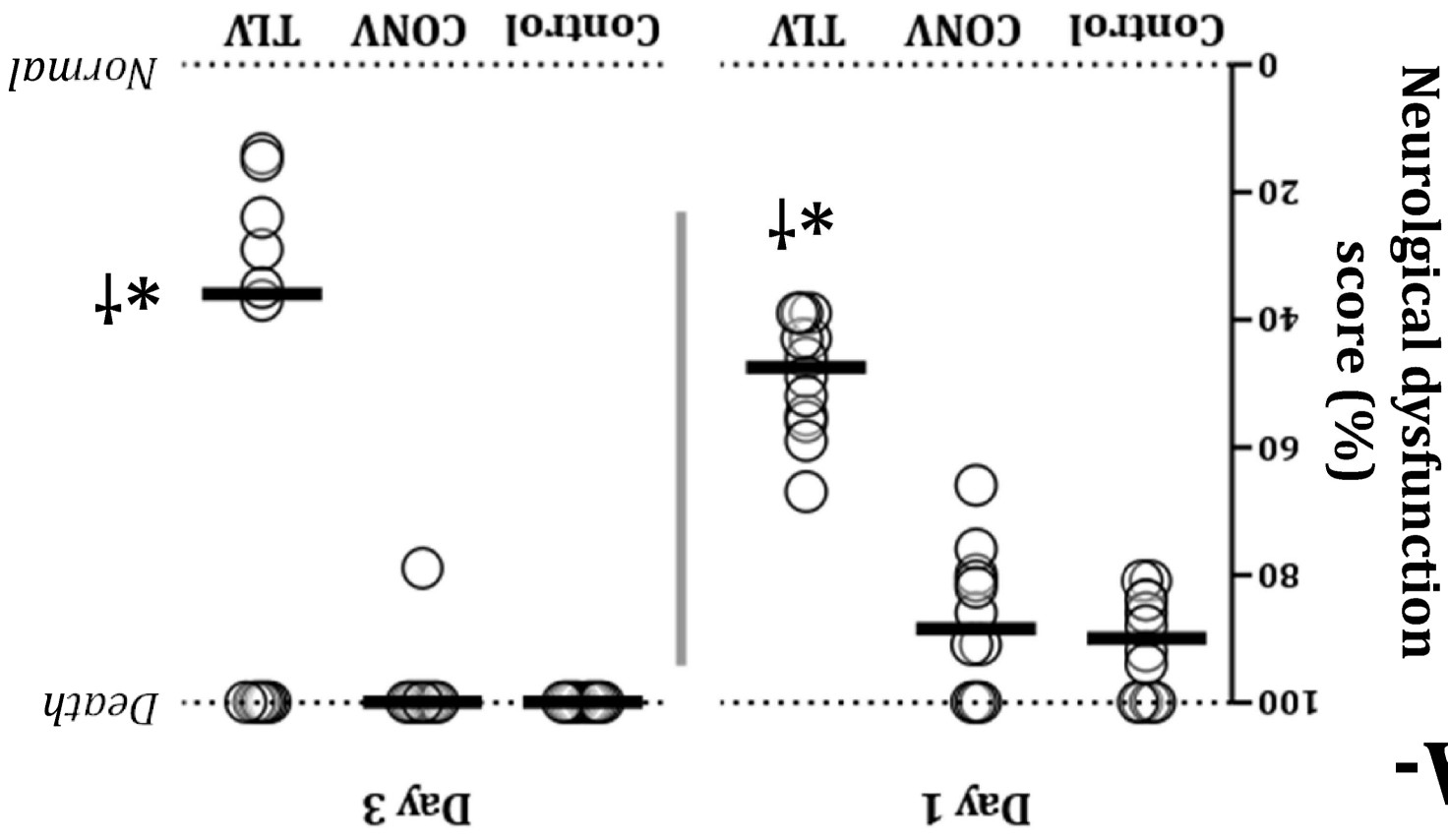

**B-****A-**

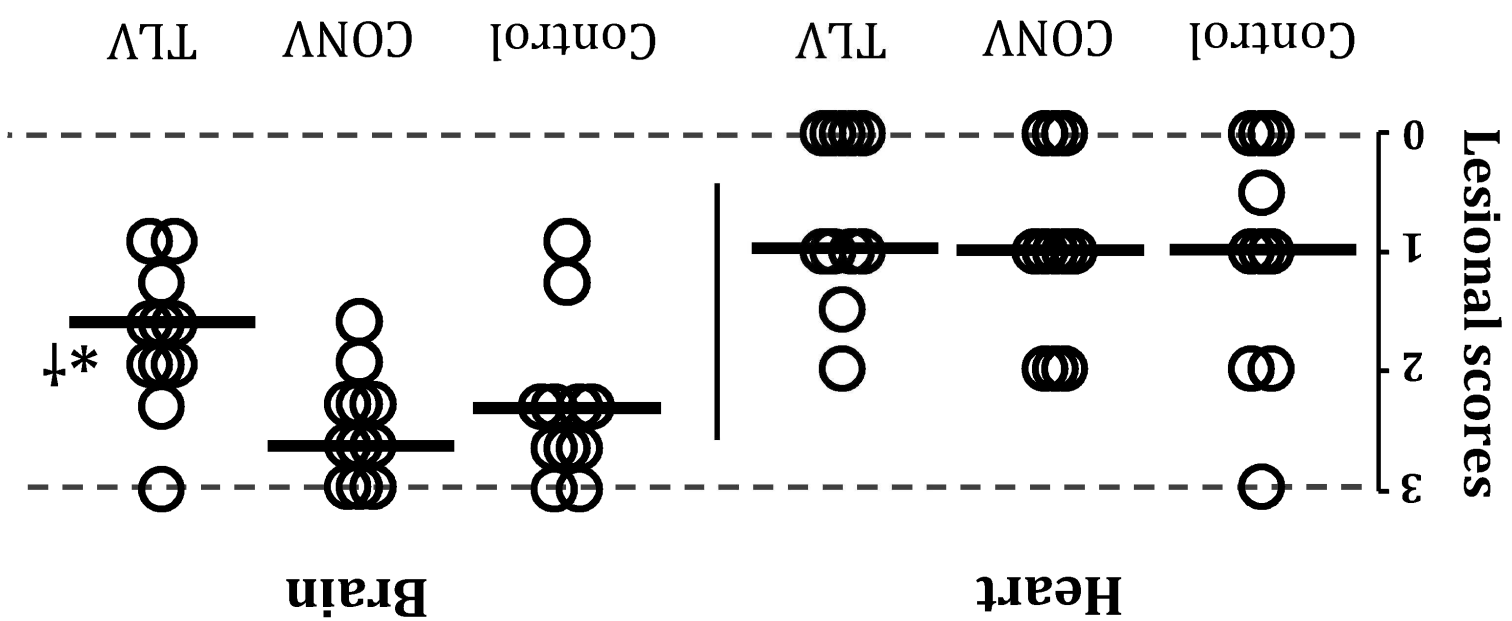
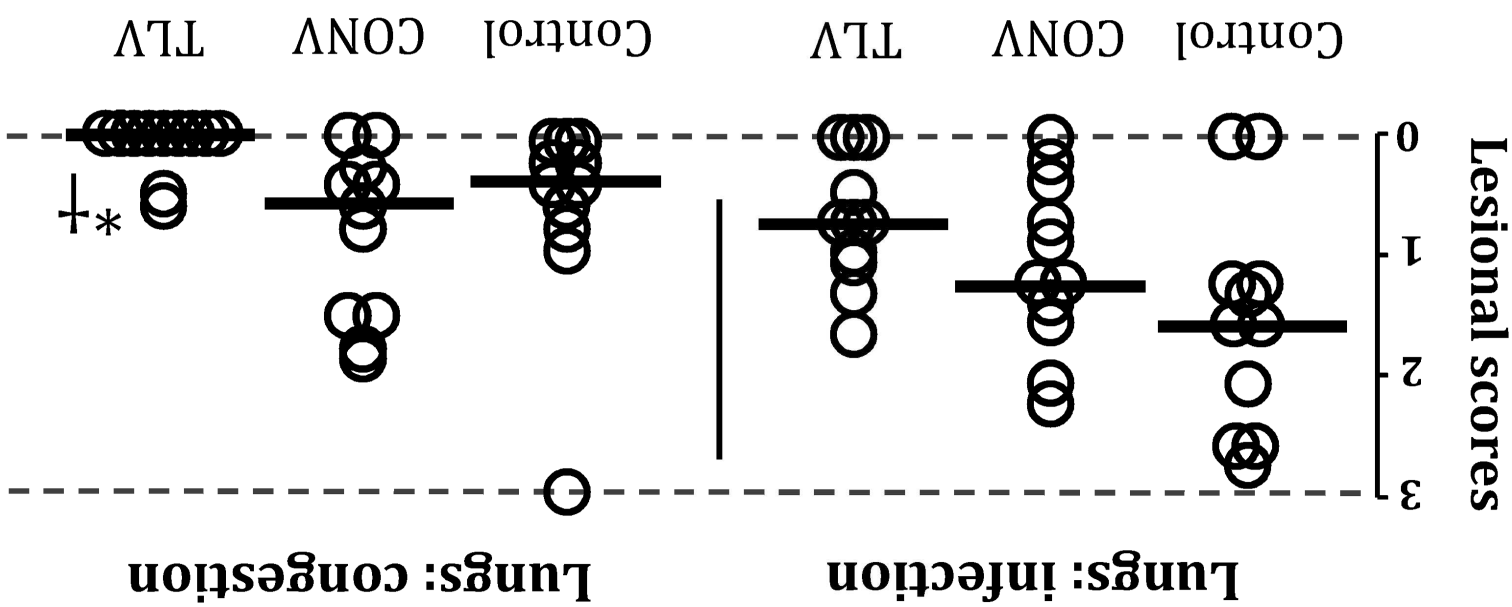
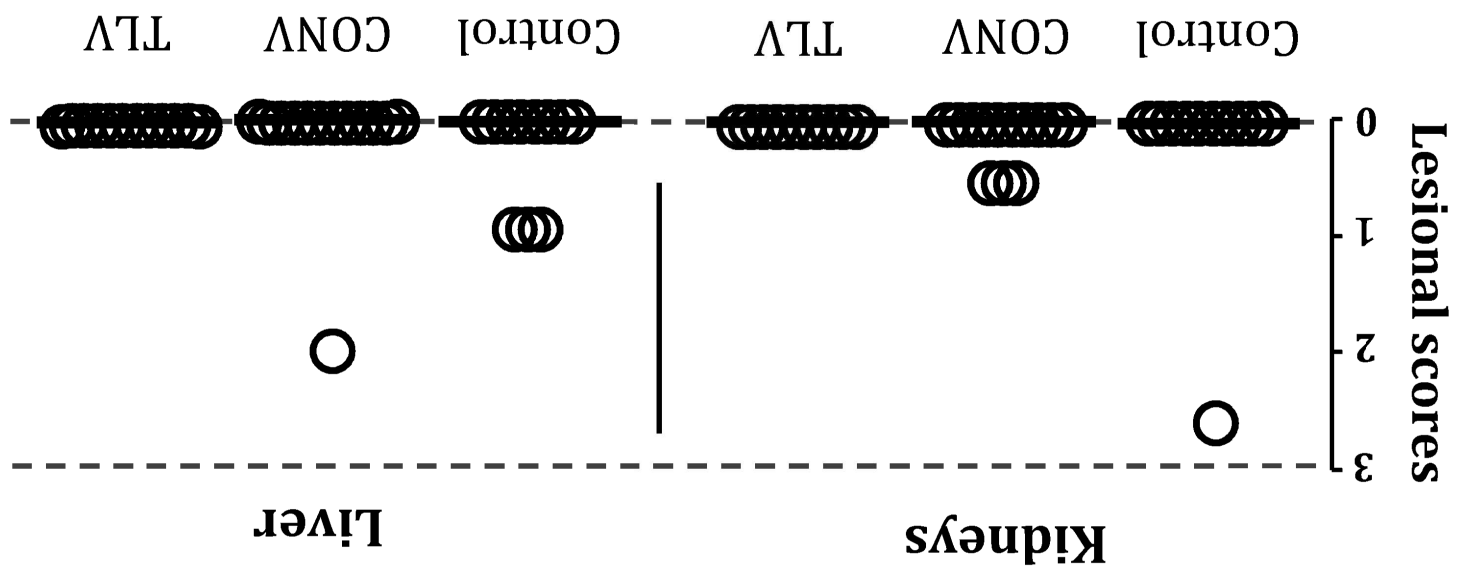

**ROS production  
(AU/g/min)**

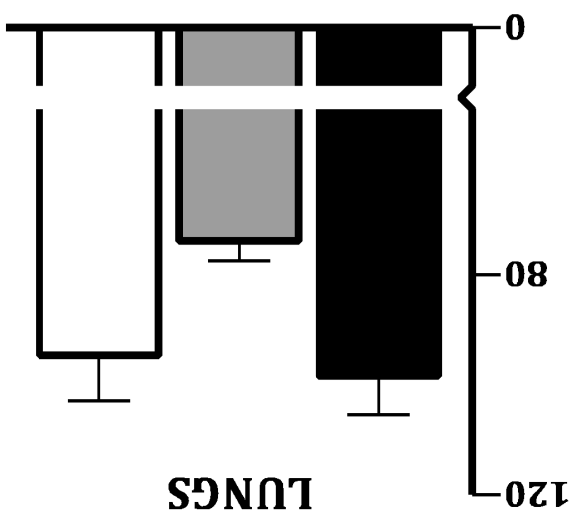

**ROS production  
(AU/g/min)**

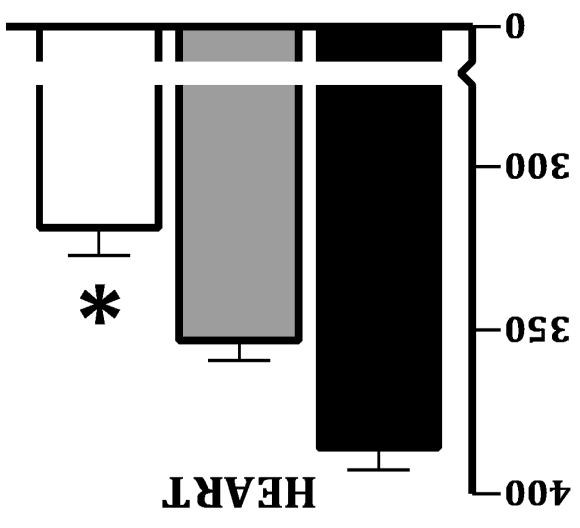

**ROS production  
(AU/g/min)**

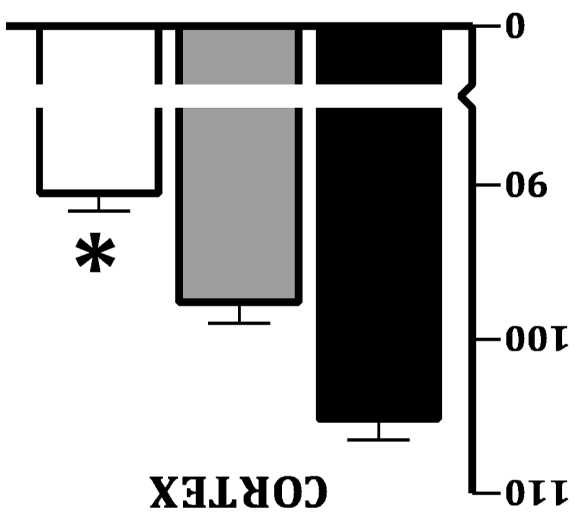

**ROS production  
(AU/g/min)**

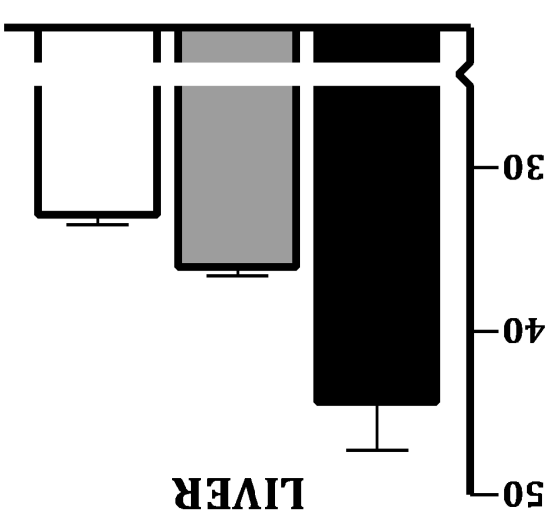

**ROS production  
(AU/g/min)**

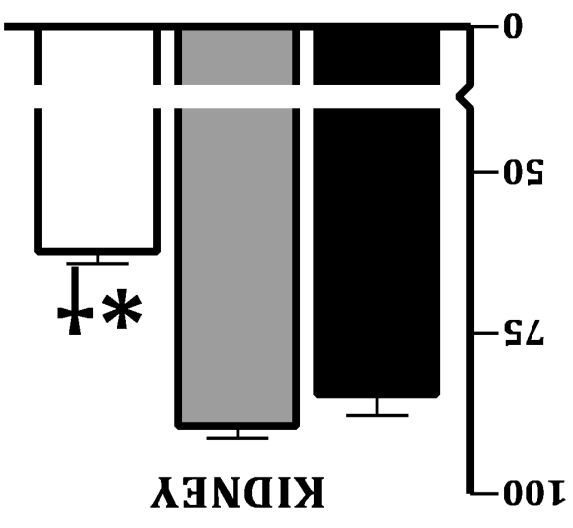

**ROS production  
(AU/g/min)**

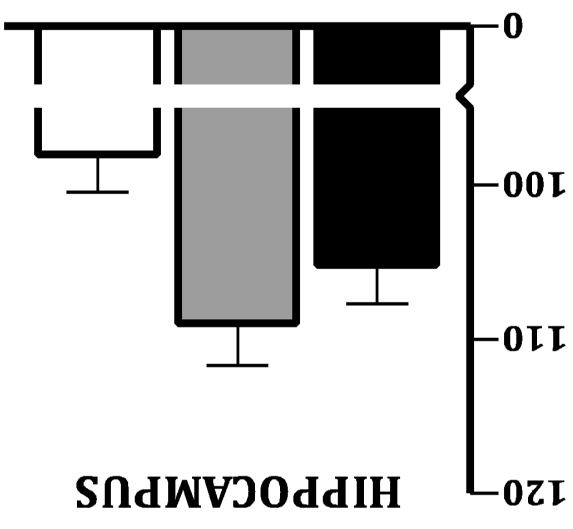

**A-** Evans blue dye vascular leakage ( $\mu\text{g/g}$ )

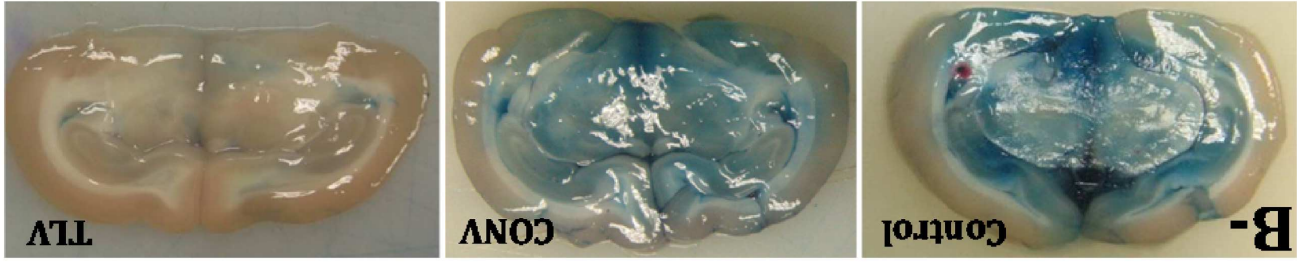
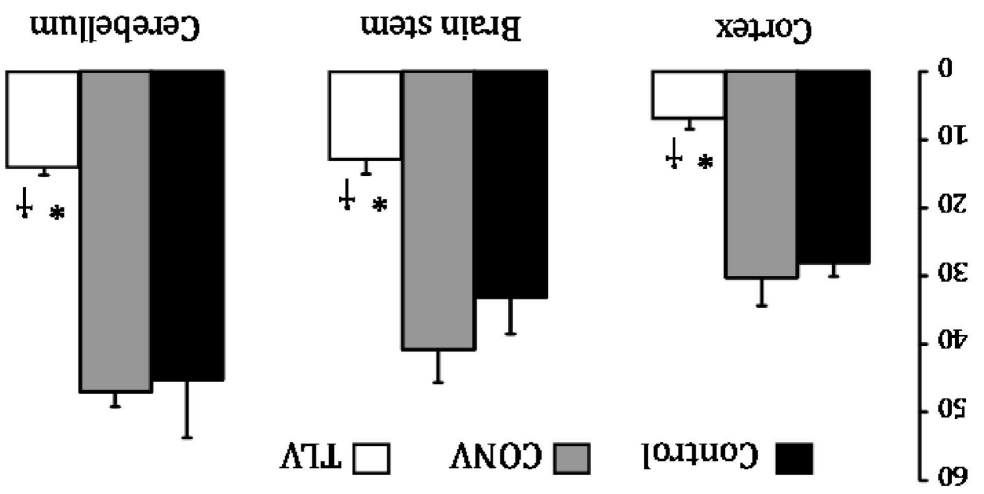

**C-**

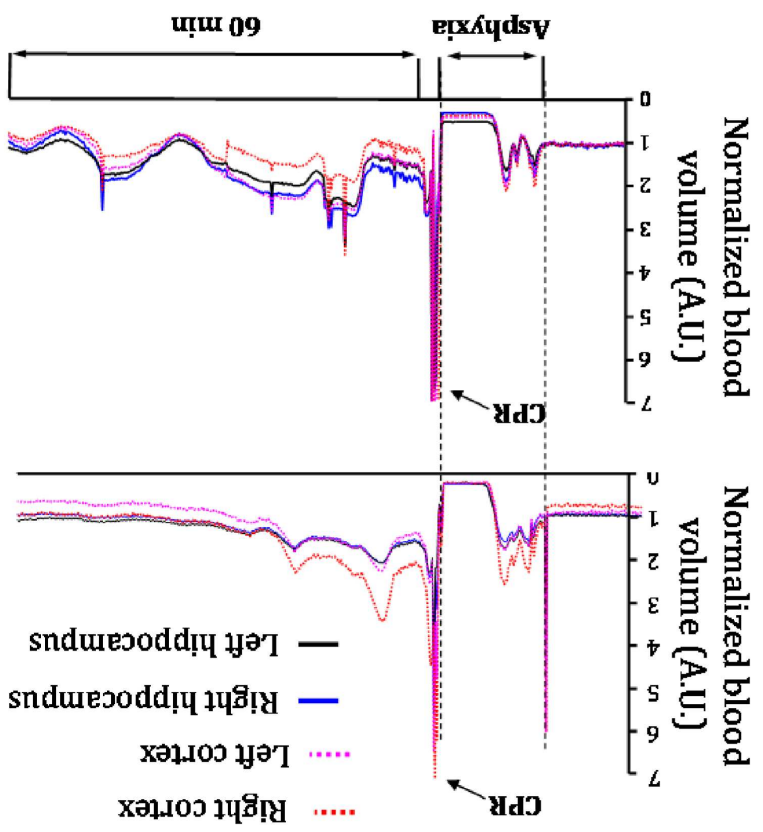
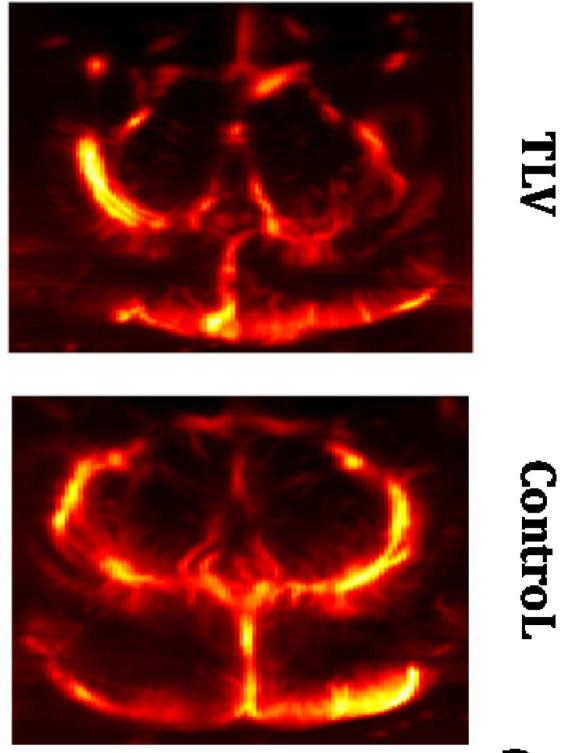

**D-**

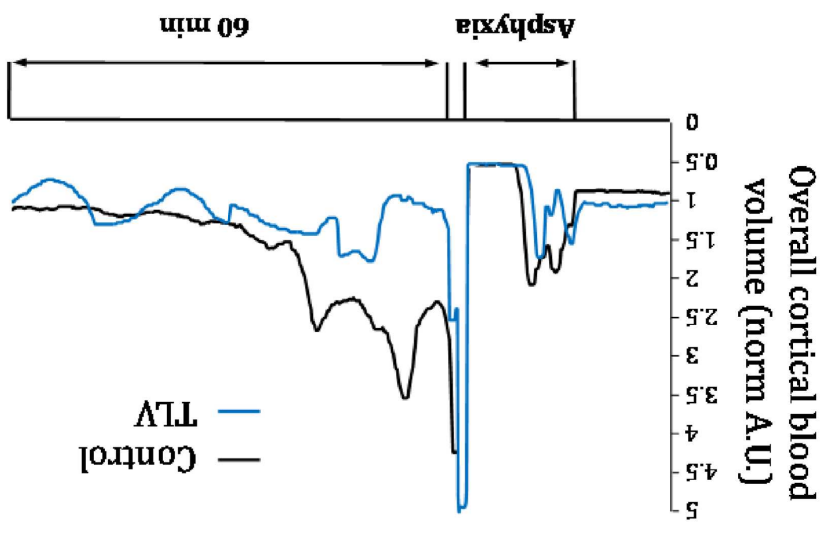

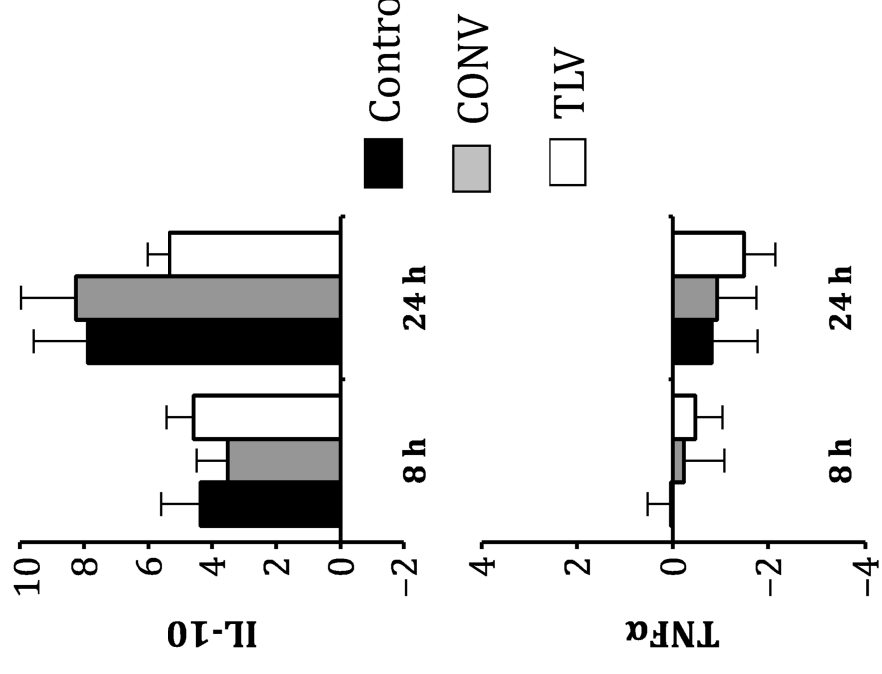
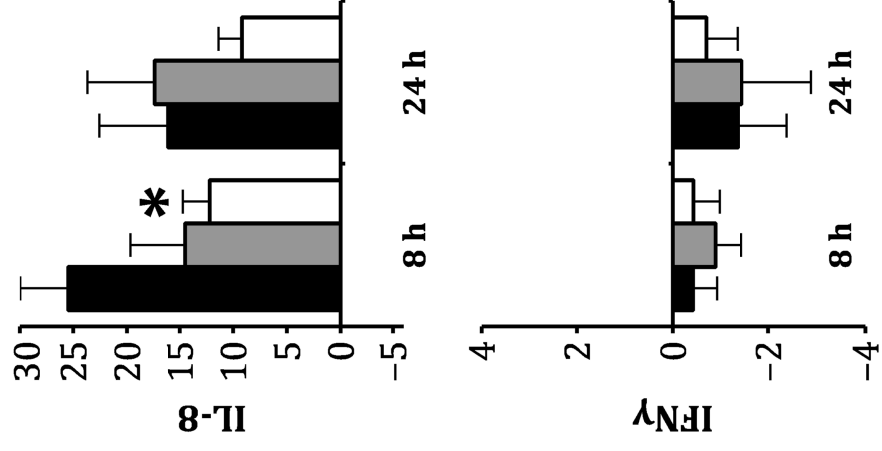
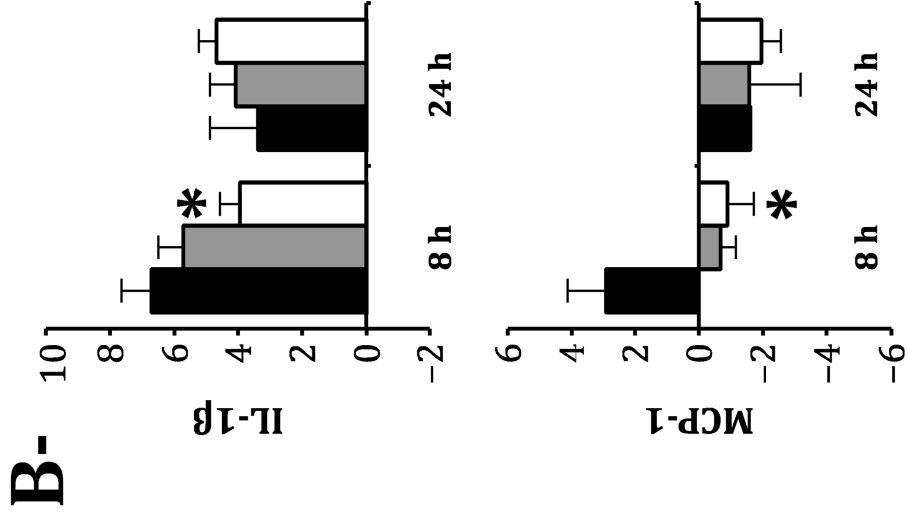
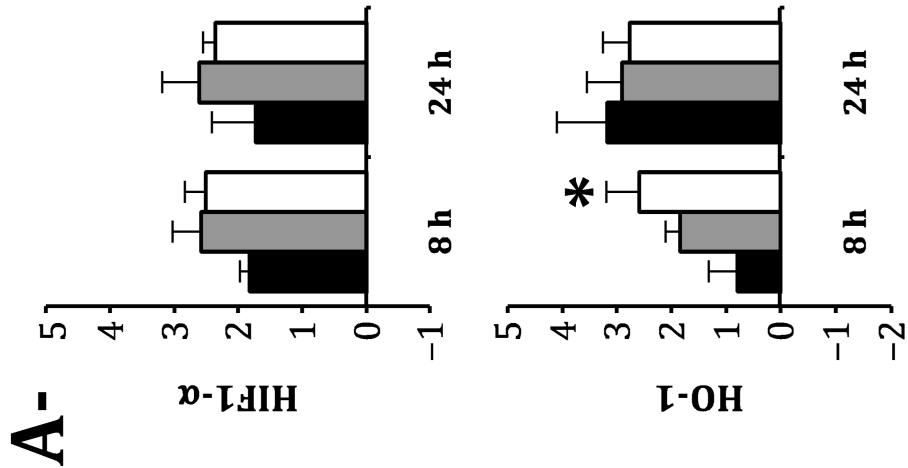



## **Supplemental Method**

### *Investigated parameters during the survival follow-up*

Rectal, oesophageal and tympanic temperatures were monitored using thermal probes (Harvard Apparatus, Paris, France). External electrocardiogram and invasive arterial blood pressure were continuously recorded (Notocord, Croissy-sur-Seine, France). Blood samples were withdrawn at baseline and at 30 min, 180 min and 360 min after cardiac arrest for blood gases and biochemical analyses.

### *Quantitative real-time PCR procedure*

Total RNA was extracted from blood using Tempus™ Spin RNA Isolation Kit (Applied Biosystems). The cDNA synthesis was performed on 1 µg of tot RNA using AffinityScript QPCR cDNA Synthesis kit (Stratagene). Quantitative PCR was performed using Brilliant II SYBR Green Master Mix (Stratagene) on a Biosystems ABI PRISM 7900HT Real-time PCR System. The amplification conditions were 10 min at 95°C, followed by 40 cycles of 15 seconds at 95°C, 30 seconds at 59°C and 15 seconds at 72°C. For IL18 and RPL5 the qPCR conditions were 10 min at 95°C, followed by 40 cycles of 15 seconds at 95°C, 30 seconds at 60,5°C and 15 seconds at 72°C. Expression levels were normalized to housekeeping gene RPL5. Transcripts levels were expressed as fold change from baseline levels.

### *Reactive oxygen species production measurement with electron paramagnetic resonance (EPR) spectroscopy*

Tissue were incubated in Krebs-HEPES buffer containing the spin probe 1-hydroxy-3-methoxycarbonyl-2,2,5,5-tetramethylpyrrolidine hydrochloride (CMH; Noxygen, Elzach, Germany). Spectra of the oxidized product of CMH (CM°) were recorded with an X-band spectrometer (MS-400; Magnettech, Berlin, Germany) and expressed arbitrary unit normalized per milligram of protein and per minute.

### *Blood brain barrier assessment using Evans Blue Dye administration*

In another set of experiments, rabbits were submitted to the same procedures of cardiac arrest and resuscitation for blood brain barrier integrity evaluation. Thirty minutes after cardiac arrest, Evans Blue Dye (EBD 4%, 3 ml/kg) was administered intravenously. Life support was further maintained during 2 h after which the rabbits were euthanized and the brain washed by 250 ml of saline (0.9%) through each carotid arteries. The brain was then sampled and slices of 1 mm were prepared and photographed. Cerebral cortex, cerebral trunk and cerebellum were further isolated and homogenized using formamide (1 ml / 100g) during 48 h at 37°C. After centrifugation, the absorbance was measured at 620 nm. The corresponding concentration of EBD was calculated using a calibration curve. It was expressed in µg/g of brain tissue.

### *Cerebral blood volume measurement*

A last set of experiments consisted in cerebral hemodynamics investigation during cardiac arrest and resuscitation using ultrafast ultrasound Doppler imaging, as previously described (1, 2). The rabbits underwent craniotomy and a linear ultrasound probe (192 elements, 7 MHz, 200 µm pitch; SuperSonic Imaging®, Aix-en-Provence, France) was positioned on the brain. Animals were subsequently submitted to the protocol described previously (Control and TLV groups only). Life support and brain imaging were pursued during one hour after cardiac arrest.

**Supplemental Table 1:** Rabbit neurological deficit grading scale (3-5)

		Maximum score
<u>Level of consciousness</u>		
Normal	0	
Clouded	5	
Stuporous	10	
Comatose	25	25
<u>Respiration</u>		
Normal	0	
Abnormal	5	5
<u>Cranial nervs</u>		
Vision	1	
Light reflex	1	
Oculocephalic	1	
Corneal	1	
Facial sensation	1	
Auditory	1	
Gag reflex	1	7
<u>Motor and sensory function</u>		
Flexor response to pain (Front)	2	
Flexor response to pain (Rear)	2	
Righting reflex	10	14
<u>Gait</u>		
Normal	0	
Minimal ataxia	5	
Moderate ataxia	10	
Able to stand	15	
Unable to stend	20	
No purposeful movement	25	25
<u>Behavior</u>		
Grooming	4	
Eating/drinking	10	
Exploring	10	24
<b>Total</b>		<b>100</b>

**Supplemental Table 2:** Histological cerebral lesion severity grading scale (3-5)

---

	Score
<u>Neocortex</u>	
Normal	0
Rare ischemic neurons (<10%)	1
Frequent ischemic neurons (10-50%)	2
Majority of neurons ischemic (>50%)	3
<u>Hippocampus</u>	
Normal	0
Rare ischemic pyramidal or granule cells	1
Focal ischemic damage	2
Severe, diffuse ischemic damage	3
<u>Cerebellum</u>	
Normal	0
Rare ischemic Purkinje cells	1
10-50% ischemic Purkinje cells	2
>50% ischemic Purkinje cells	3

---

**Supplemental Table 3:** Histological lesion severity grading scale for the kidney, liver, heart and lung (3-5). For this last organ, we assessed two separate scores for the cardiogenic lesions and the infectious complication, respectively.

	Score
<i><u>Kidney</u></i>	
Normal	0
Dilated regenerative proximal tubule	1
Focal scar fibrosis	2
Extensive scar fibrosis	3
<i><u>Liver</u></i>	
Normal	0
Limited clarification of hepatocytes	1
Moderate clarification of hepatocytes	2
Extensive clarification of hepatocytes	3
<i><u>Heart</u></i>	
Normal	0
Very rare foci of cardiomyocyte necrosis	1
Rare foci of cardiomyocyte necrosis	2
Frequent foci of cardiomyocyte necrosis	3
<i><u>Lung (cardiogenic lesion)</u></i>	
Normal	0
Limited congestion and/or serous edema	1
Moderate congestion and/or serous edema	2
Extended congestion and/or serous edema	3
<i><u>Lung (infection)</u></i>	
Normal	0
Limited foci of bronchopneumia	1
Moderate foci of bronchopneumia	2
Extended foci of bronchopneumia	3

**Supplemental Table 4:** Primers used for the quantification of mRNA expression of immunity, inflammation and/or hypoxia pathway markers with Reverse Transcriptase Quantitative Polymerase Chain Reaction (RT-QPCR),

Name	Sequence (5'→ 3')
IFN gamma FB - F	TGCCAGGACACACTAACCAGAG
IFN gamma FB - R	TGTCACTCTCCTCTTTCCAATTCC
TNF alpha FB - F	AGATTGAGCCCGGAACATC
TNF alpha FB - R	GCCTAGGTCTGGGTGACAAC
RPL5 - F	TCCCTCACAGTACCAAACGA
RPL5 - R	TTCTGCCCCATAATGTGCTT
RPLP0 - F	CGACGTGCAGCTGATAAAGA
RPLP0 - R	GGGTTGTAGATGCTGCCATT
HO - F	CCTTCGCAGGCACCAG
HO - R	CTGGGAGAGGCTGCTGAG
HIF - F	GGCTTCTGTTATGAGGCTTACC
HIF - R	AAACAGTTCATCTGTGCCTTCA
MCP1 - F	CTCAGTGAAGAGGCTAATGAGCTA
MCP1 - R	TCTGCTTGGGGTCAGCA
IL 1 beta - F	CCACAGTGGCAATGAAAATG
IL 1 beta - R	GCTGGATGCCCTCGTCT
IL 8 - F	CCCAAATTTATCAAAGAATTGAGAG
IL 8 - R	TTGGGGTCCAGGCAGA
IL 10 - F	ATGCCAAGCCTTGTCGGAGATG
IL 10 - R	TGATGGCTGGACTGTGGTTCTCAG

*HIF1*, hypoxia-inducible factor; *HO*, heme oxygenase ; *IFN*, interferon; *IL*, interleukin; *MCP-1*, monocyte chemoattractant protein-1; *RP*, ribosomal protein, *TLR*, toll-like receptor; *TNF α*, tumor necrosis factor-α.

## **Legend of Supplemental Figure 1**

### **Supplemental Figure 1: Histological appearance of brain and lungs in the different groups**

*Panel A:* Normal histological appearance of the cerebral cortex in a rabbit from the TLV group.

*Panel B:* Pathological appearance with multifocal necrosis (arrows) of the cerebral cortex in a rabbit from the Control group.

*Panel C:* Normal histological appearance of the hippocampus in a rabbit from the TLV group.

*Panel D:* Pathological appearance with multifocal necrosis (arrows) of the hippocampus in a rabbit from the Control group.

*Panel E:* Normal histological appearance of the lungs in the TLV group.

*Panel F:* Congestive lesions of the lungs in a rabbit from the TLV group (black arrows).

*Panel G:* Extensive alveolar edema in rabbits from the Control.

*Panel H:* Extensive alveolar edema in rabbits from the CONV group.

*CONV, Conventional cooling group; TLV, Total liquid ventilation.*

**Supplemental Figure 1**

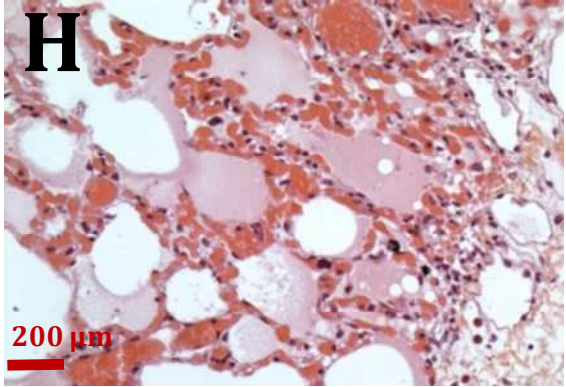
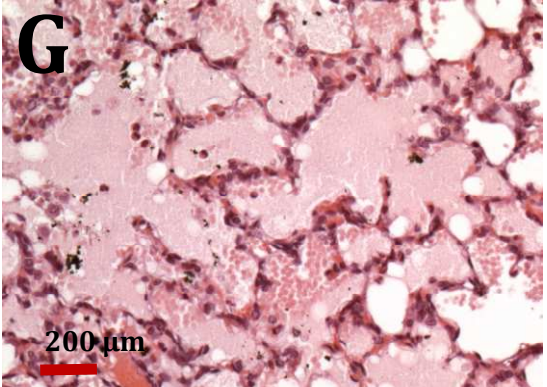
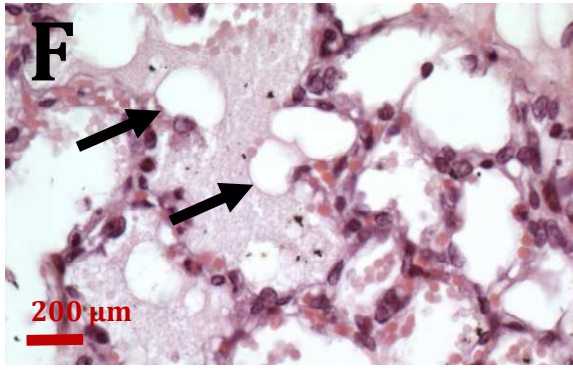
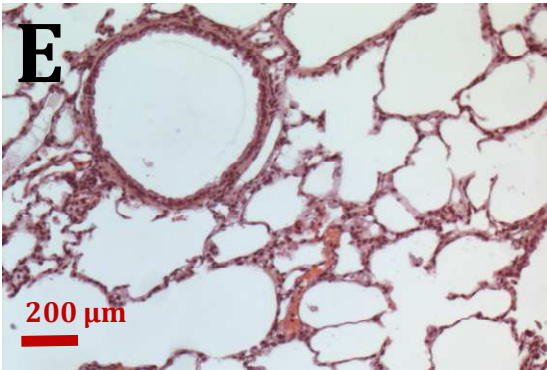
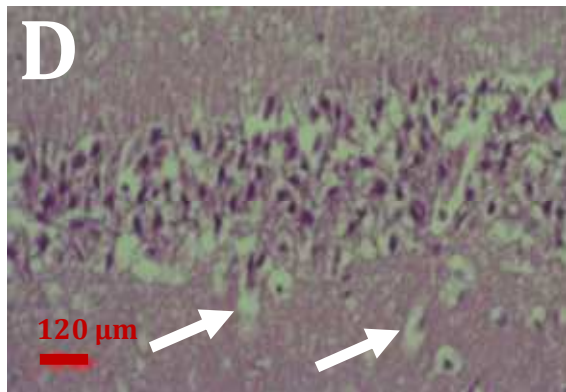
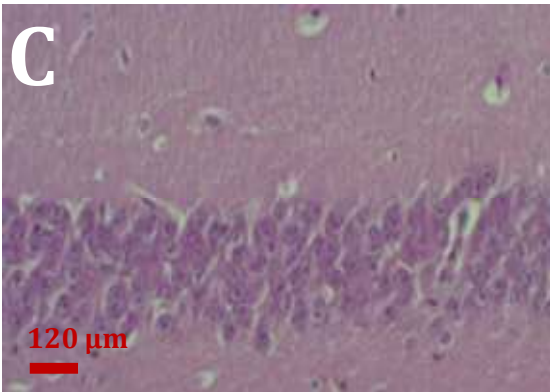
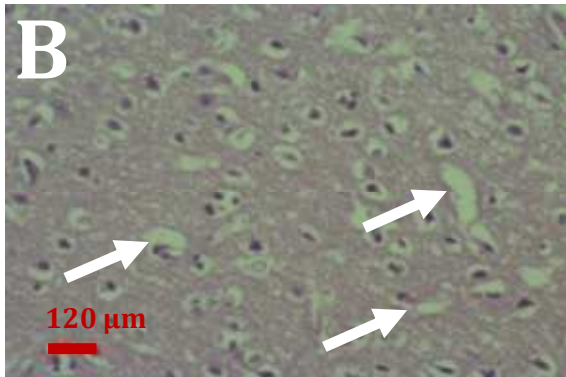
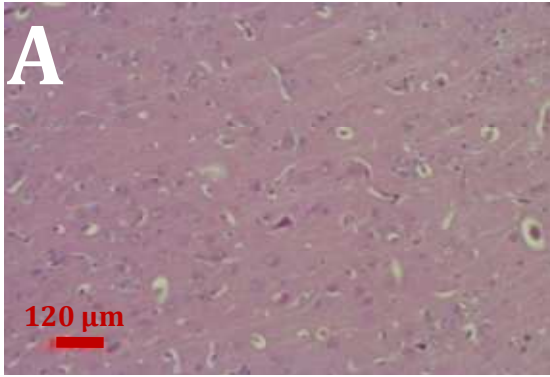



## **References of the Supplemental Material**

1. Demene C, Pernot M, Biran V, et al. Ultrafast Doppler reveals the mapping of cerebral vascular resistivity in neonates. *J Cereb Blood Flow Metab* 2014;34:1009-1017.
2. Tanter M, Fink M. Ultrafast imaging in biomedical ultrasound. *IEEE Trans Ultrason Ferroelectr Freq Control* 2013;61:102-119.
3. Baker AJ, Zornow MH, Grafe MR, et al. Hypothermia prevents ischemia-induced increases in hippocampal glycine concentrations in rabbits. *Stroke* 1991;22:666-673.
4. Chenoune M, Lidouren F, Adam C, et al. Ultrafast and whole-body cooling with total liquid ventilation induces favorable neurological and cardiac outcomes after cardiac arrest in rabbits. *Circulation* 2011;124:901-911, 901-907.
5. Darbera L, Chenoune M, Lidouren F, et al. Hypothermic Liquid Ventilation Prevents Early Hemodynamic Dysfunction and Cardiovascular Mortality After Coronary Artery Occlusion Complicated by Cardiac Arrest in Rabbits. *Crit Care Med* 2013;41:e457-465.