

# Mutor: Drone Chorus of Metrically Muted Motors

Mo H. Zareei

Victoria University of Wellington

mo.zareei@vuw.ac.nz

Dale A. Carnegie

Victoria University of Wellington

dale.carnegie@vuw.ac.nz

Ajay Kapur

California Institute of the Arts

akapur@calarts.edu

Dugal McKinnon

New Zealand School of Music

gal.mckinnon@nzsm.ac.nz

## ABSTRACT

The use of mechatronics and robotics in works of sound art and music has grown over the past decade. Among the significant body of work done in these fields, this paper narrows down its focus on those that employ mechatronics and robotics in order to explore and investigate new sonic possibilities associated with these technologies. Followed by a discussion on characteristics of such works of mechatronic sound art, this paper presents Mutor: a new mechatronic sound-object that utilizes the sonic artifacts of mechatronic systems—specifically, the noise of a DC motor—as its primary source of sound, and modulates it rhythmically and timbrally.

## 1. INTRODUCTION

Since the early days of the hybridization of music and robotics, electromechanical devices such as linear actuators, servos, and DC motors, have been the basic key components in the creation of new instruments, musical systems, and works of kinetic sound art. However, regardless of their popularity and numerous positive features such as high durability, extensive availability, relatively cheap cost, and the fact that they are fairly easy to work with, one major issue, which many works of musical robotics are challenged by, is their relatively loud “noise”. The integration of robotics in the musical world, in many cases, has been geared towards creating instruments that are inspired by already existing musical instruments, but have automated and/or augmented performance capabilities: an approach that has become associated with the term ‘musical robotics’. In this approach, motors and actuators are popular tools, used to create motions that help generate the automatic actions such as beating, stroking, plucking, etc. In other words, motors and actuators are used as means to create the mechanical force, which then leads to the sound production, and not as the source of sound itself. Therefore, in such systems, the noise produced by these electromechanical devices is often musically extraneous, and an unwanted by-product of the sound production mechanism. Accordingly, finding a workaround to overcome this issue can be a matter of concern in developing such musical robotic systems. For instance, in Kritaanjali, a robotic harmonium that uses a solenoid-based actuation method, even though 24V sole-

noids have been used to press the harmonium keys “the minimum voltage possible to press each key was applied” [1], in order to prevent the actuation noise caused by the solenoids.

Creating automated and augmented versions of already existing traditional musical instruments is not, however, the only path taken by the investigators of music technology, sound art, and robotics. There is, in fact, a great number of works of robotic and mechatronic sound art which explore the “extra-musical” noise rather than musical sound. For the purpose of this paper and for the sake of semantic clarity, we refer to this latter approach as ‘mechatronic sound art’. Contrary to the ‘musical robotics’ trend, here the sonic resemblance to what is expected from already existing musical instruments is replaced by a focus on the conventionally perceived “extra-musical” sonic territories provided by the machines and technologies of the new era. The ideological roots of these works of mechatronic sound art originate in Luigi Russolo’s art of noises, his fascination for the post-industrial revolution noise, and his orchestra of noise-intoners [2]. In these works, preserving the integrity and purity of a certain musical sound that is expected from a musical instrument—either melodic or percussive—is not a concern, and in fact, the goal is to investigate “non-musical” noises and tones. Therefore, the sonic by-product of the components that comprise a mechatronic system would not be considered as big of a threat to works of mechatronic sound art.

Alongside and influenced by the ‘mechatronic sound art’ movement and in a step forward towards further exploration of new sonic territories affiliated with the very nature of robotic and mechatronic music, this paper introduces Mutor: a mechatronic instrument in which the buzzing of DC motors and actuation noises of solenoids are not to be perceived as some form of unwanted aural by-product, but as the instrument’s main sonic output.

Section 2 provides an overview of the background and related works in the field of ‘mechatronic sound art’. Section 3 will introduce Mutor, presenting its design and technical features. Section 4 will present the conceptual and compositional ideas behind the instrument, and section 5 will be dedicated to the conclusion and a short discussion of potential future works.

## 2. BACKGROUND AND RELATED WORK

As noted in the previous section, amongst the numerous works of sound art and music that incorporate robotic and mechatronic techniques, some are directed towards creating systems that are influenced by already existing musi-

cal instruments, following a deterministic—and at times anthropocentric—approach in order to achieve certain musical output. Many significant examples of this, which we refer to as ‘musical robotics’, can be found in Murphy’s review article [3]. However, the purpose of this paper is to focus on the other trend identified as ‘mechatronic sound art’ in the previous section. Therefore, this section passes over the musical robotics trend to focus on significant examples—both early, and contemporary—of works related to the mechatronic sound art trend, along with its conceptual background<sup>1</sup>. Yet, it should be noted that this classification is inevitably a loose one, both semantically and conceptually, and the dividing line between these trends is blurry in many cases.

## 2.1 Noises of the Machine

With Luigi Russolo’s futurist manifesto, the integration of non-musical machine noises of the industrial revolution era in music was officially announced. In an effort to break out of the “limited variety of timbres” offered by the orchestra, Russolo called for sonic-artistic investigation of industrial technologies, claiming that “the evolution of music is comparable with the multiplication of machines” [2]. In collaboration with Ugo Piatti, he constructed a set of noise-intoners, many of which incorporated a simple mechanism of exciting a diaphragm using a vibrating string that was in contact with a rotating wheel. The tension of the string was controlled manually using a lever, and the speed of vibration was determined either manually using a crank, or by a motor and using a switch. Based on the type of noise they created, he divided his instruments into six distinct families, and used them in a number of performances throughout Europe. These performances drew strong responses from audiences and though none of the original noise-intoners have survived, his groundbreaking ideas continue to influence the artists and musicians in the realm of experimental music and sound art to this day.

Russolo’s instruments, whose pictures and sketches I had long known, still fascinated me even after hearing them play [5].

– Godfried-Willem Raes

In spite of their varied aesthetic and artistic approaches, the majority of the works that can be identified as ‘mechatronic sound art’ are rather indeterministic, or chaotic systems, in appreciation of the sonic by-products of the new technologies. More significantly, they deal with ‘noise’ rather than ‘musical sound’. Therefore, it is reasonable to consider Russolo’s works and ideas as the ideological father of this trend.

## 2.2 Early Days of Mechatronic Sound Art

In keeping with the anti-authoritarianism tendencies of the 1960s, the Logos Foundation was established by Godfried-Willem Raes, one of the key precursors of mecha-

<sup>1</sup> For a more expansive comparison of the “musical robotics” and “mechatronic sound art” trends see [4].

tronic sound art, in defiance of what he regards as the “authoritarianism of the music production and reproduction” [5]. As an effort to trespass the boundaries dictated by the music industry, this defiance was mainly realized in the form of the design and construction of new “electroacoustic” instruments and soundsculptures—many of which are discussed in [5]—using electromechanical machines and technologies. Another influential forerunner of the movement is Trimpin, whose numerous works of sound art and kinetic sculpture [6], are at the cornerstone of the mechatronic sound art movement. Trimpin’s methodology is often the sonic recycling of found objects and obsolete machines using mechatronic techniques in order to create kinetic soundsculptures and mechatronic sound-objects. This practice is extended in works such as Gordon Monahan’s *Multiple Machine Matrix* [7], in addition to a number of others [3].

The contributions of pioneers such as Raes and Trimpin, along with those of soundsculptors Jean Tinquelly, Joe Jones, and Martin Riches (discussed in Alan Licht’s *Sound Art* [8]), paved the way for development of mechatronic sound art.

## 2.3 Contemporary Mechatronic Sound Art

The trace of Russolo’s intonarumori and his futurist manifesto can be clearly noticed in the works of contemporary Canadian sound artists Nicolas Bernier and Martin Messier. In particular, their collaborative project *La chambre des machines*, is a direct homage to Russolo’s instruments. This project is a live performance in which two “machines made of gears and cranks are manipulated to produce a sound construction at the crossroads of acoustics and electronics” [9] (see Figure 1).



**Figure 1.** *La chambre des machines* by Nicolas Bernier and Martin Messier.

Clearly inspired by Russolo’s intonarumori, both in terms of their appearance and sound production mechanisms, these instruments use mechanical means to generate sound. However, the mechatronic and automation technologies are not investigated here as they are in the artists’ solo projects. Messier’s *Sewing Machine Orchestra* is an audiovisual project in which “computer processing transforms the functional sounds of eight 1940s Singer sewing machines, mounted on stands, into a vivid, dancing weave of hums, whirrs, and beats, accompanied by suitably pulsating lights” [10]. Bernier’s award-winning *Frequencies (a)* is also an audiovisual performance “combining the sound of mechanically triggered tuning forks with pure digital sound waves. The perform-

er is triggering sequences from the computer, activating solenoids that hit the tuning forks with high precision” [11], while the triggered sounds are accompanied by synchronous beams of bright light (see Figure 2).

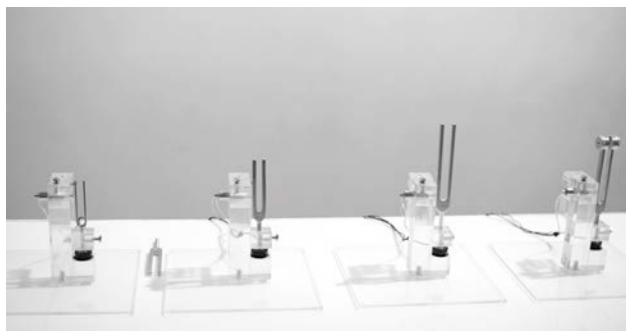

**Figure 2.** *Frequencies (a)* by Nicholas Bernier.

Contemporary examples of mechatronic sound art, where the basic mechatronic components are used as the source of sound itself, can be found in the numerous and remarkable installation works of Swiss artists Zimoun and Pe Lang. In a significant number of their solo and collaborative works, Zimoun and Pe Lang use a large number of what they refer to as “prepared” actuators in order to create large-scale sound installations (see Figure 3). These prepared actuators are small DC motors or solenoids that are attached to external objects such as pieces of wire, cardboard boxes, cotton balls, etc. The simultaneous actuation of motors or solenoids puts the external objects into motion, creating a large number of sound-object units that form an ambient wall of sound and fill the entire gallery space. According to Murphy, Zimoun’s and Pe Lang’s works “involve reductionist sculptures that pare sound-making elements down to their pure forms” [3].

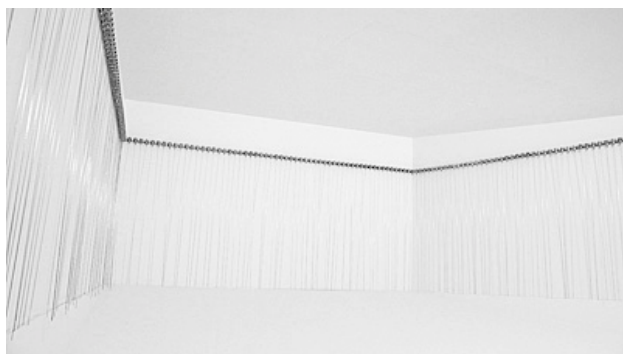

**Figure 3** 216 Prepared DC motors, Filler Wire 1.0mm, By Zimoun (2009/2010)

Other contemporary examples of using mechatronic devices to create works of sound art, primarily through actuation of various “non-musical” objects, can be found in Murphy’s *Metal+Motors* (2011), and Daito Manabe’s *Motor Music Test* (2013). *Metal+Motors* is an installation “consisting of a variety of DC motor actuators striking metallic objects in response to ultrasonic sensor data” [12] that are derived from audience’s movements in the gallery space. Similarly, *Motor Music Test* consists of an array of metal sheets, each attached to a servomotor. The servomotors rotate the metal sheets at various speeds and

directions, within various degrees and ranges, creating variation of rhythmic phrases from a combination of the sound of spinning sheets and the buzzing of the motors (Figure 4).

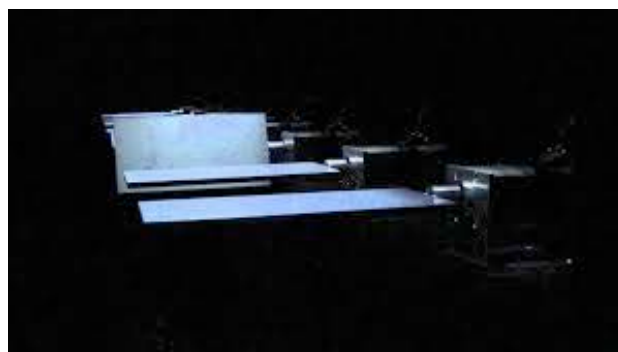

**Figure 4** *Motor Music Test* by Daito Manabe

Most of the contemporary examples of mechatronic sound art presented in this section share at least two significant common features. First, they exhibit a very minimalistic approach in terms of design, form, and structure, deploying factors such as repetition and iteration to their full extent. Second, from a technical point of view they employ mechanisms that are purely based on actuation of non-musical objects through basic mechatronic components. *Mutor* draws inspiration from both of these features. In doing so, it takes the second feature to an even more minimalistic degree by shifting the sonic focus from the external actuated object onto the mechatronic component itself.

### 3. MUTOR

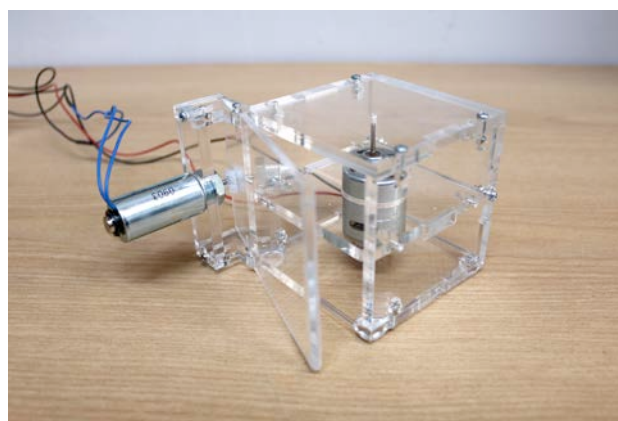

**Figure 5** *Mutor* (First finished version)

*Mutor* is a mechatronic sound-object in which the sound of a DC motor is controlled and manipulated, in terms of frequency, timbre, and amplitude, through mechatronics and microcontroller programming. It is comprised of a DC motor placed in a transparent acrylic box, and a push-type solenoid mounted on the edge of the box’s only pivoting side (see Figure 5). Microcontroller programming is used to control the motor’s rotation speed and the solenoid movements. Different rotation speeds create a continuous range of different frequencies, while solenoid actuations result in shutting or opening the box’s door,

modulating the amplitude and timbre of the motor's sound.

### 3.1 Design

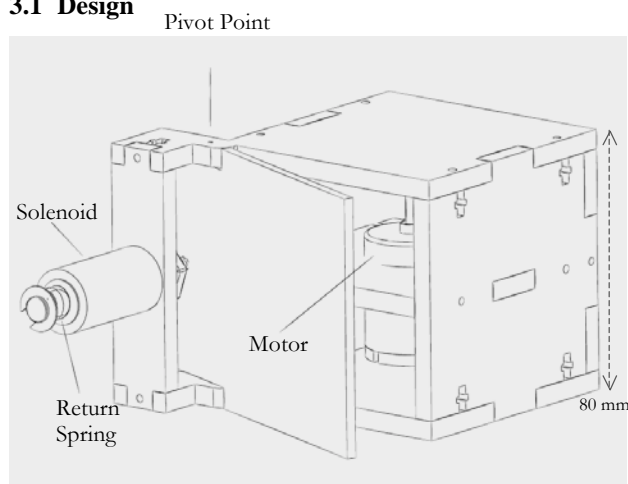

Figure 6 Mutor parts and design sketch

Mutor is designed using CAD technology. After creating 3D models of the mechatronic components, the box and the solenoid bracket are drafted and put together in the 3D mechanical CAD program SolidWorks (Figures 6 and 7). Several prototypes were designed to reach the optimum sizes and dimensions, both in terms of practicality and aesthetics. The enclosure is then manufactured using computer-aided manufacturing (CAM) technology. All parts are laser-cut from 6 mm thick sheets of clear acrylic, except for the pivoting side that was cut out of 3 mm thick acrylic in order to further facilitate its revolving motion.

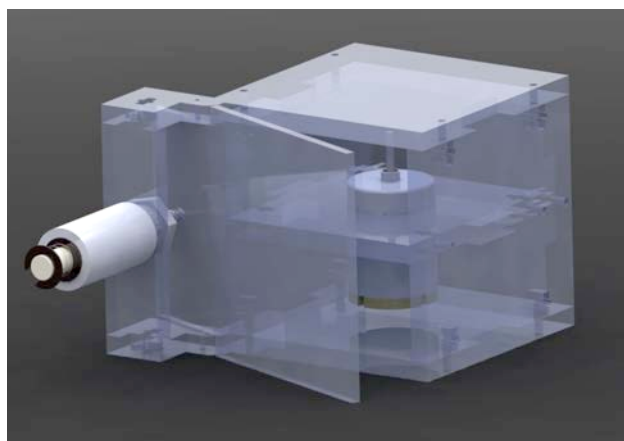

Figure 7 3D model of Mutor designed in SolidWorks.

### 3.2 System Overview

Figure 8 presents a flowchart of the different parts of the system and demonstrates the process of sound production. MIDI messages are sent to the Arduino board, which has been flashed to a MIDI device using HI-DUINO firmware [13]. The driver board is a custom-designed PCB and has been designed as an Arduino shield. Appropriate output PWM signals are generated by the Arduino in response to the incoming MIDI velocities, and then used to drive the motor and the solenoid through

the driver board. Separate MIDI pitch values correspond to each component (i.e. motor and solenoid).

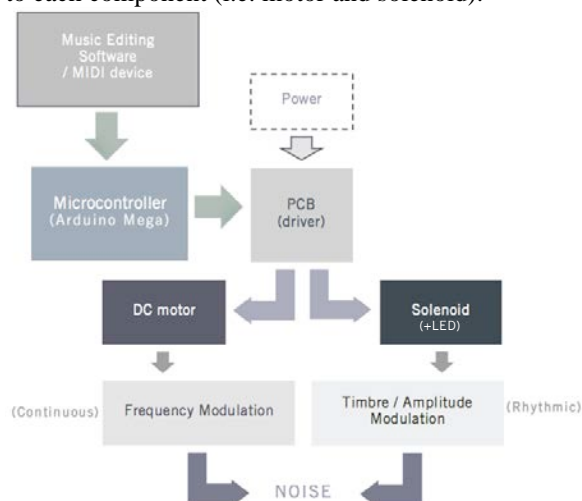

Figure 8 System overview

For the MIDI messages sent to the motor, different MIDI velocity values correspond to different motor speeds, and subsequently, different “buzzing” frequencies. For the MIDI messages sent to the solenoid, different MIDI velocity values correspond to the actuator stroke length. Higher stroke lengths result in wider angular displacement of the box's door, and therefore, more significant timbre and amplitude modulations. It should be noted that a push style solenoid has been used in this design whose shaft is mounted onto the outer edge of the pivoting side (the box's door). Therefore, as long as there are no MIDI inputs for the solenoid (i.e., the actuator is in rest position), the box's door is shut and the continuous buzzing of the motor is in the “muted” state. Once there is a note-on message, the solenoid receives a PWM signal corresponding to the MIDI velocity number and pushes the outer edge of the door, putting the motor's sound in the “un-muted” state, changing the amplitude and timbre of the buzzing. Transition from the muted to the unmuted state creates an effect on the motor's sound that is perceptually similar to that of a formant filter or a “wah-wah” effect, and the sound of the box's door shutting adds a percussive element to the aural output. A narrow strip of felt has been glued to the edge of the box's door to dampen the percussive sound, making the variations of the motor's sound more easily perceptible. In the latest version of Mutor, a strip of bright LEDs enclosed in a thin diffused acrylic box has been mounted on the back wall of the box in order to boost the audiovisual expressivity.

### 3.3 Audio Analysis

#### 3.3.1 Frequency Domain

In order to study some of the frequency response and sonic characteristics of Mutor, a series of tests were carried out on recordings of the instruments in both “muted” and “unmuted” states. These samples were used to make an analysis of audio feature extractions such as spectral roll-off, spectral centroid, and zero-crossing. Considering the significant degree of inconsistency and noisiness of

the sound of a DC motor, these feature extractions were obtained from average FFT data of one-second-long recordings of Mutor at various MIDI velocity inputs, i.e. various speeds, with the following specifications:

- Sample Rate: 44100 sample/s
- Window Function: Hanning
- Window Size: 1024 samples

The data presented in the following graphs are therefore calculated as the average of approximately 43 samples ( $44100/1024 \cong 43$ ). Two separate series of recordings are conducted for muted and unmuted states. In the muted recordings, the box’s door is kept shut by not sending any input to the solenoid, and for the unmuted recordings, a MIDI velocity of 127 is sent to the solenoid in order to keep the box’s door at its widest open angular position. In both cases, the speed of the motor is changed by sending different MIDI velocities starting from 127 and decreased by 10 every step, down to MIDI velocity 7. The graphs presented in Figure 9 exhibit the data from muted and unmuted in comparison to each other.

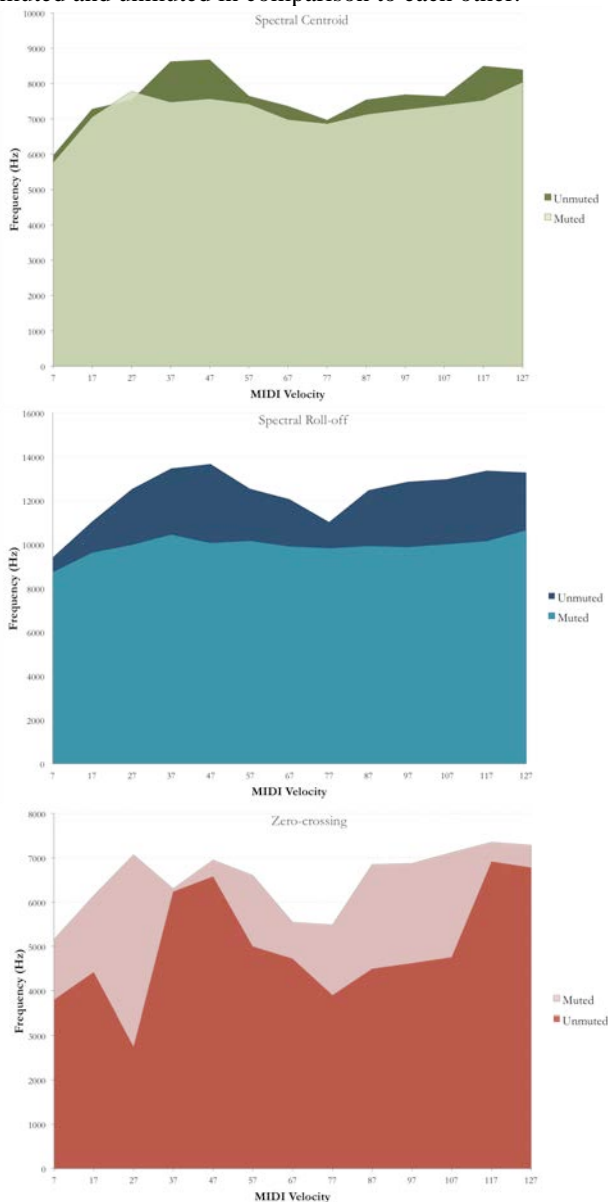

Figure 9 Analysis of audio feature extractions of Mutor’s recordings in “muted” and “unmuted” states

The spectral centroid chart at the top illustrates the concentration of the center of mass of the audio signal, at both muted and unmuted states, within the relatively narrow frequency band of 7 kHz and 9 kHz for most MIDI velocity values. However, this center of mass is somewhat higher when the instrument is in the unmuted state, a difference that can be perceived as a timbral variety between the muted and unmuted states. This timbral difference can be more notably viewed in the middle chart, where the difference between the frequencies marking 80% percent of the power distribution of the audio signals in muted and unmuted states is significant. According to this chart, opening the box’s door results in extending the frequency range to higher frequencies, overtones, and partials. Lastly, the highly wavering behavior of the (scaled) number of zero-crossings in both states vouches for the instrument’s noisy sonic quality. The lack of any meaningful form of periodicity and consistency of the signal at various speeds implies that there is no predictable or linear correlation between the motor’s speed and its frequency behavior. Therefore, although various MIDI velocity inputs for the motor’s speed do change the tone of the motor in terms of frequency and timbre, this change does not follow a certain pattern.

### 3.3.2 Time Domain

Figure 10 presents the visualizations of a one-bar long pattern played by Mutor in MIDI, waveform, and spectrum demonstrations. Part (a) shows the MIDI notes used to trigger the motor and the solenoid. C#-2 is used to send four 8<sup>th</sup> note-long MIDI messages of maximum velocity (127) to the solenoid, at a BPM of 120, in order to open the box’s door for an 8<sup>th</sup> note, shutting it for another 8<sup>th</sup> note, and repeating this procedure another three times throughout the bar. C-2 is used to send a velocity of 127 to the motor, keeping its speed and therefore frequency constant throughout the bar. Part (b) shows the waveform changing over a period of 2 seconds (one bar in a BPM of 120). Part (c) demonstrates the spectrum distribution of the audio recordings of Mutor generated by this MIDI pattern.

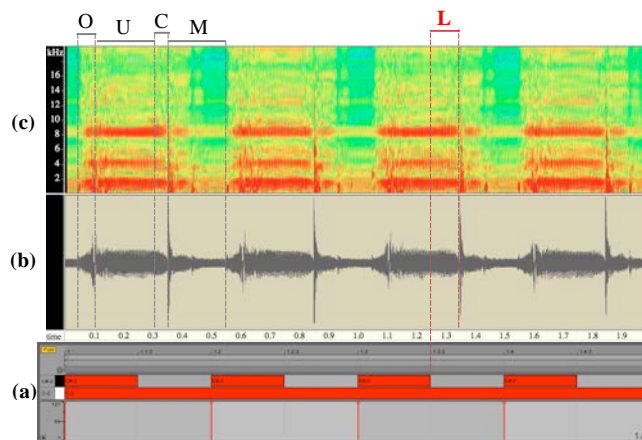

Figure 10 Visualization of a one-bar-long pattern played bar Mutor: (a) MIDI (b) Waveform (c) Spectrum

Different time intervals in each cycle have been marked at the top of the figure. These labels represent the following time intervals between (or during):

**O:** the note-on message and opening the door

**U:** the unmuted state

**C:** the note-off message and closing the door

**M:** the muted state

**L:** the latency between the note-off message and the unmuted state

As can be seen in the figure, there is a latency (L) of approximately 100 ms between receiving the note-off message and the actual shutting of the box's door. This is of course due to the time that the solenoid's return spring needs to decompress, and is therefore unavoidable. However, considering that it is this action that results in the most distinctive percussive element of the instrument, this latency should be carefully taken into account by the user or composer, especially when the intention is to create specific rhythms.

Furthermore, the relatively consistent changes in the shapes of the waveform and the spectrum show that, given a constant speed of motor, while constant MIDI input values are applied to the solenoid, changes in the audible output of Mutor would be relatively consistent and predictable.

#### 4. COMPOSITIONAL & CONCEPTUAL APPROACHES

Mutor and many other examples of mechatronic sound art discussed earlier, share a conceptual background with a portion of experimental electronic music often referred to as glitch. Regardless of the different mediums they use, mechatronic sound art and glitch music both focus on sonic by-products of the technologies they incorporate, and highlight the potential aesthetics of these by-products by utilizing them as the primary source of sound.

The appreciation of new sounds has been core to the creation and reception of an extensive number of works of contemporary sound art and experimental music, but as Landy points out a great deal of these works “[are] of marginal relevance to today’s society in terms of its appreciation [of them]” [14]. Landy argues that this separation of art from life is a consequence of “art for art’s sake” doctrine. He suggests certain “access tools” that can help such works of sound art and experimental music—or in his terminology, “works of organized sound”—be appreciated by an audience broader than just the peer musicians and sound artists. According to him, such access tools can equip the work with what he calls the “something to hold onto” factor, raising its accessibility, and therefore, appreciation by a greater audience. Conventional use of rhythm and pitch are among a number of “something to hold onto” factors suggested by Landy. In addition, he remarks on the strong effect of the visual aspect of sound-based works on enhancing their accessibility:

It has been my experience that inexperienced listeners tend to find sound-based works more accessible when

introduced in a convincing manner within *audiovisual contexts* regardless of what they are [14].

He claims that integration of visual accompaniments of some sort help the general (or non-expert) audiences connect to works of experimental music and sound art more easily:

I have discovered that when presenting sound-based music in video, theater, performance art, dance, and installation contexts, the number of viewers is normally greater than what I would reach within music [14].

Employing Landy’s ideas on accessibility of sound-based works, Mutor focuses on two of his “something to hold onto” factors: visual accompaniment and metric rhythms.

##### 4.1 Visual Accompaniment

Unlike digitally produced works of glitch music, the sound-production mechanism in Mutor is physical and this physicality is presented in a fully visible form. Generating sound through an entirely mechanical apparatus that is held together in a transparent enclosure, fully embodies the visual and bodily aspect of the work, boosting the audiovisual expressivity. The significance of this audiovisual expressivity in Mutor and similar works of mechatronic sound art is pointed to by Fowler:

Many of these mechanical instruments are... intended for looks as much as for sound [15].

##### 4.2 Metric Rhythms

Similar to many works of laptop-produced glitch music where pulse-based and metric rhythms are used as a platform to bring the ignored and unwanted technological noise to the domain of aural attention, Mutor is designed in a way that makes it perfectly capable of producing metric rhythms. The effect of metric rhythms is realized in simple timbral modulation of the motor’s sound, and further highlighted by the percussive clacks of the box’s revolving door. While the primary sound source here is the continuous buzzing of a DC motor, these minimal rhythmic modulations help remove this sound from its everyday context where it is unwanted and ignored, creating a framework in which the potential aesthetics of such sound are explored. This minimalistic approach was not only inspired by the contemporary works of mechatronic sound art, but also from Luigi Russolo’s approach towards making his own instruments:

These instruments, because of their extreme simplicity, are already perfect enough so that they need only small modifications of a secondary nature [2].

##### 4.3 Drone Chorus of Metrically Muted Motors

While the use of inexpensive components and CAD/CAM techniques make Mutor easily reproducible, mechatronics and microcontroller programming make it feasible to interact with and control a number of Mutors

in an ensemble setting. In such scenario, potential rhythmic characteristics of the system can be further explored, using any combination of synchronous, syncopated, phasing, or interlocking rhythmic patterns. Using a number of Mutors in an ensemble setting also replaces the buzz of a single motor with a more timbrally diverse and richer drone chorus of sounds (see Figure 11). Such an ensemble of mechatronic sound-objects, equipped with MIDI compatibility and/or autonomous functionality, can be used not only in an interactive live-performance, but also in a self-governed installation setting, where the physicality and bodily effect of the instruments play a predominant role<sup>2</sup>.

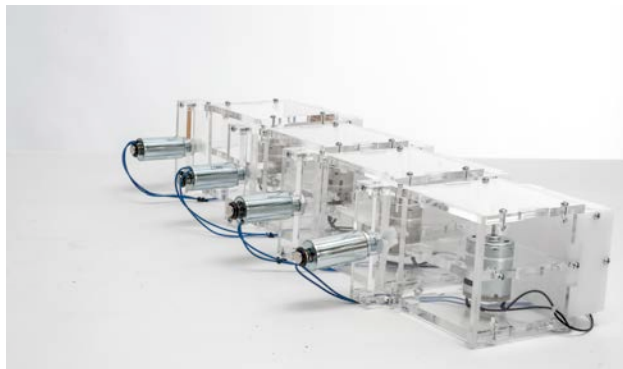

**Figure 11** A set of four Mutors (latest version)

## 5. CONCLUSION & FUTURE WORK

This paper presents a mechatronic sound art project that consists of new mechatronic sound-objects entitled Mutor. In these sound-objects, the continuous buzzing of DC motors is modulated rhythmically and timbrally in an effort to highlight the potential sonic aesthetics of some of the most prevalent electromechanical devices in modern everyday technologies. In order to do so, two main strategies suggested by Leigh Landy are employed:

1. Increasing audiovisual connectivity by placing emphasis on the visual aspect of the work.
2. The use of conventional and accessible rhythmic structures, i.e. metric and pulse-based rhythms.

Future works will include experimentation with different types of motors with various sonic (and visual) features in order to broaden the work's timbral and frequency scopes. Additionally, other methods of timbre, amplitude, and frequency modulation will be explored in order to create different variations of Mutor. Subsequently, a large-scale ensemble using different types and variations of the instrument will be manufactured and used to create large-scale installations and live-performances.

## 6. REFERENCES

[1] A. Kapur, J. Murphy, and D. Carnegie, "Kritaanjli: A Robotic Harmonium for Performance, Pedagogy and Research."

[2] L. Russolo, *The Art of Noises*. New York: Pendragon Press, 1986.

[3] J. Murphy, A. Kapur, and D. Carnegie, "Musical Robotics in a Loudspeaker World: Developments in Alternative Approaches to Localization and Spatialization," *Leonardo Music J.*, vol. 22, pp. 41–48, Jan. 2012.

[4] M. H. Zareei, D. A. Carnegie, and A. Kapur, "Rasper: a Mechatronic Noise-intoner," In *proceedings of the International Conference on New Interfaces for Musical Expression*, London, UK, 2014.

[5] G.-W. Raes, "A Personal Story of Music and Technologies," *Leonardo Music J.*, vol. 2, no. 1, pp. 29–35, Jan. 1992.

[6] A. Focke and Trimpin, *Trimpin: contraptions for art and sound*. Seattle, Wash. University of Washington Press, 2011.

[7] G. Monahan, "Gordon Monahan - Multiple Machine Matrix - Sound Installation," [www.gordonmonahan.com](http://www.gordonmonahan.com).

[8] A. Licht, B. Fontana, S. Roden, J. Dubuffet, A. Burr, C. Curtis, B. Gál, and D. A. Monsters, *Sound art: Beyond music, between categories*. Rizzoli International Publications, 2007.

[9] Nicolas Bernier and Martin Messier, "La chambre de machines," <http://www.lachambrede machines.com/>.

[10] J. Cowley, "Bernier and Messier," *Music Works*, no. 115.

[11] Nicolas Bernier, "Frequencies (a)," [www.nicolasbernier.com](http://www.nicolasbernier.com).

[12] J. Murphy and A. Kapur, "The Gallery as an Instrument: Using Remote Sensing Technology to Interface with Musical Robotics."

[13] D. Diakopoulos and A. Kapur, "HIDUINO: A firmware for building driverless USB-MIDI devices using the Arduino microcontroller," in *Proceedings of the International Conference on New Interfaces for Musical Expression*, Oslo, Norway, 2011.

[14] L. Landy, *Understanding the art of sound organization*. Cambridge, Mass.: MIT Press, 2007.

[15] C. B. Fowler, "The museum of music: A history of mechanical instruments," *Music Educ. J.*, vol. 54, no. 2, pp. 45–49, 1967.

<sup>2</sup> Video documentation of Mutor is available at: <http://www.m-h-z.net/mutor>