

Mini Symposium

IEA Wind Task 52: Lidar-Assisted Control and Turbulence Estimation

1. Integration of LIDAR simulation and LIDAR-assisted control within OpenFAST – Andrew Russell, Idcore
2. Field testing results of data-driven lidar assisted control on an active-stall regulated wind turbine – Mark Pitter, ZX Lidars
3. Using scanning lidar data to predict future wind flows – Wouter Engels, TNO
4. Assessment of measurement-data from nacelle-based Lidar-devices regarding their usability for the estimation of turbulence intensity – Jakob Von Eisenhart Rothe, DNV
5. Feedforward control and load characterization for a 15-MW wind turbine using a spinner-mounted single-beam lidar – Alfredo Peña, DTU



Implementation of LIDAR simulation within OpenFAST and LIDAR-assisted control within ROSCO

Andrew Russell, Maurizio Collu, Alasdair McDonald, Philipp Thies, Aidan Keane and Alexander Quayle

Wind Energy Science Conference, 23rd-26th May 2023, Glasgow, UK



EPSRC & NERC Industrial CDT
for Offshore Renewable Energy www.idcore.ac.uk



Introduction

Aims of this work

- Implementation of LIDAR simulation within the InflowWind module of OpenFAST.
- Interface with ServoDyn and ROSCO to allow for LIDAR-assisted control within OpenFAST and FAST.Farm.
- Engagement with NREL for the implementation into an official release and future collaboration.



Introduction



Integration of LIDAR simulation in OpenFAST and ROSCO

- LIDAR simulation changes proposed to NREL via GitHub pull request.
- Changes were approved:

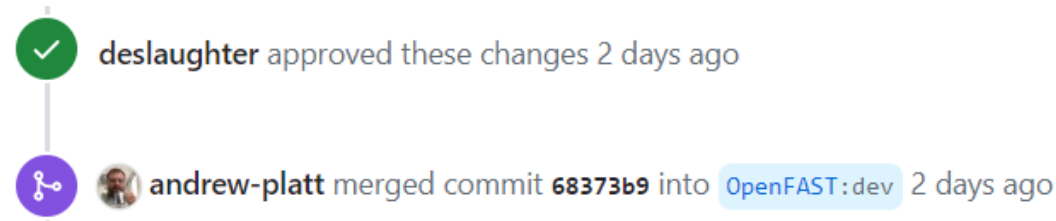

- The following additions are now present in the latest release of OpenFAST (v3.5.0).

[#1464](#) Add LIDAR simulation within InflowWind with control channels passed to controller [@Russell9798](#)

- Work ongoing to implement LIDAR-assisted control within ROSCO.



Introduction

FF control loop



WESC 2023
23 - 26 MAY | GLASGOW, UK

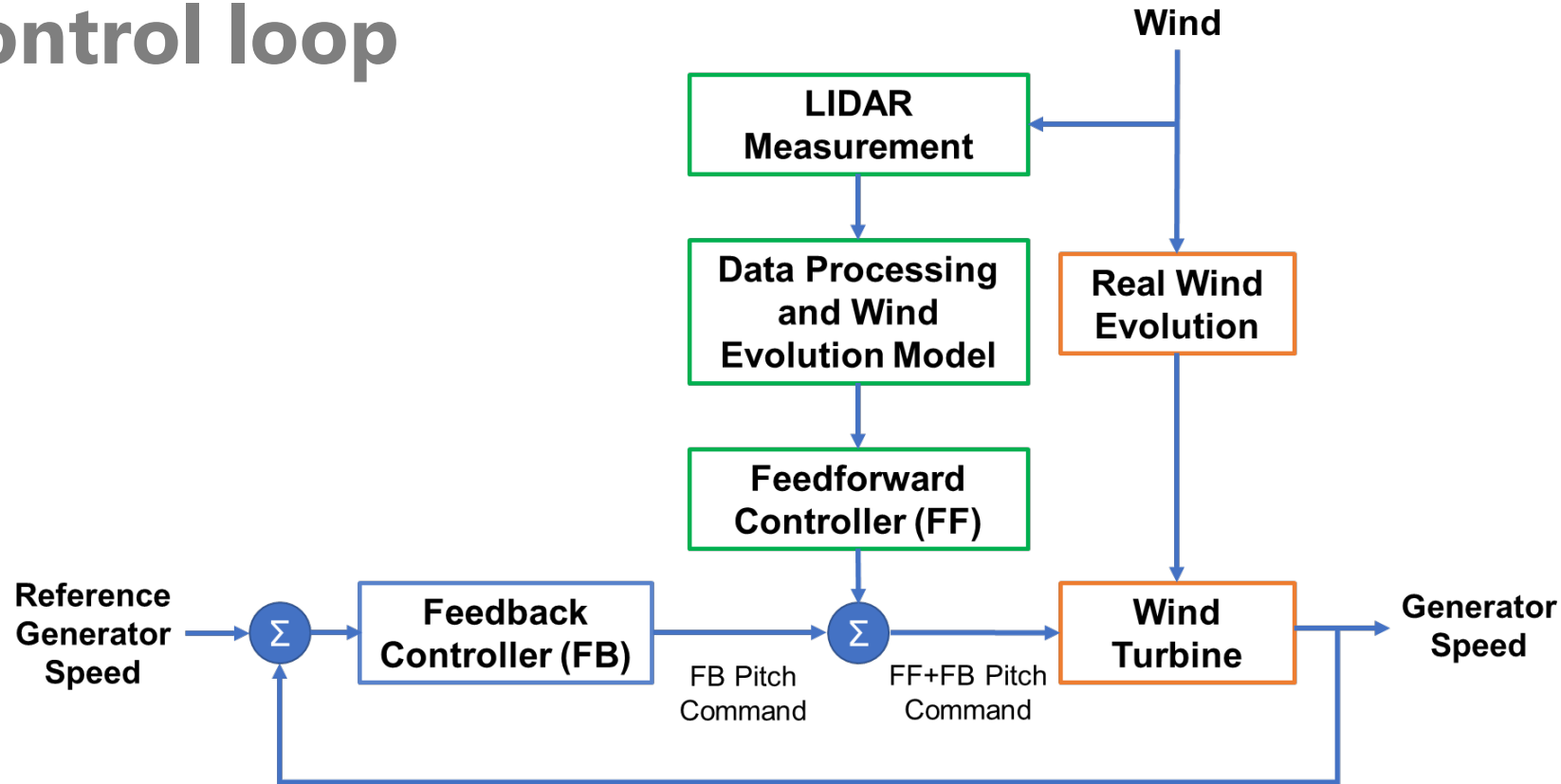

Adapted from: A. Scholbrock, P. Fleming, D. Schlipf, A. Wright, K. Johnson, and N. Wang. LIDAR-enhanced wind turbine control: Past, present, and future. In 2016 American Control Conference (ACC), pages 1399–1406. IEEE, 2016.



EPSRC & NERC Industrial CDT for Offshore Renewable Energy www.idcore.ac.uk



FLOTATION ENERGY

Simulation example

LIDAR configuration



WESC 2023
23 - 26 MAY | GLASGOW, UK

```
===== LIDAR Parameters =====
3      SensorType - Switch for lidar configuration (0 = None, 1 = Single Point Beam(s), 2 = Continuous, 3 = Pulsed)
3      NumPulseGate - Number of lidar measurement gates (used when SensorType = 3)
30     PulseSpacing - Distance between range gates (m) (used when SensorType = 3)
1      NumBeam - Number of lidar measurement beams (0-5) (used when SensorType = 1)
-200   FocalDistanceX - Focal distance co-ordinates of the lidar in the x direction (relative to hub height)
0      FocalDistanceY - Focal distance co-ordinates of the lidar in the y direction (relative to hub height)
0      FocalDistanceZ - Focal distance co-ordinates of the lidar in the z direction (relative to hub height)
0.0, 0.0, 0.0 RotorApexOffsetPos - Offset of the lidar from hub height (m)
15     URefLid - Reference average wind speed for the lidar[m/s]
0.25   MeasurementInterval - Time between each measurement [s]
False  LidRadialVel - TRUE => return radial component, FALSE => return 'x' direction estimate
1      ConsiderHubMotion - Flag whether to consider the hub motion's impact on Lidar measurements
```

Simulation example

ROSCO input configuration



```

!----- LIDAR-ASSISTED CONTROL -----
0.7          ! FF_LPFCornerFreq - Corner frequency (-3dB point) in the low-pass filters, [rad/s]
0.35         ! FF_Kp - FF proportional gain Kp
2           ! Pitch_ActTime - Feedforward pitch preview time
-0.04 0.15   ! Limits_15ms - Limits imposed on the feedforward pitch error when the measured wind speed is between 13m/s and 15 m/s
-0.015 0.05  ! Limits_13ms - Limits imposed on the feedforward pitch error when the measured wind speed is below 13m/s
36          ! NumPitchCurveFF - Number of points in the wind-pitch-Kp curve
0.4 1.4 2.4 3.4 4.4 5.4 6.4 7.4 8.4 9.4 10.4 11.4 12.4 13.4 14.4 15.4 16.4 17.4 18.4 19.4 20.4 21.4 22.4 23.4 24.4
0 0 0 0 0 0 0 0 0 0 0 0.0111 0.0888 0.1306 0.1642 0.194 0.221 0.2461 0.2697 0.292 0.3135 0.3349 0.3568 0.3778 0.398

```

Results

LIDAR simulator



WESC 2023
23 - 26 MAY | GLASGOW, UK

Motions

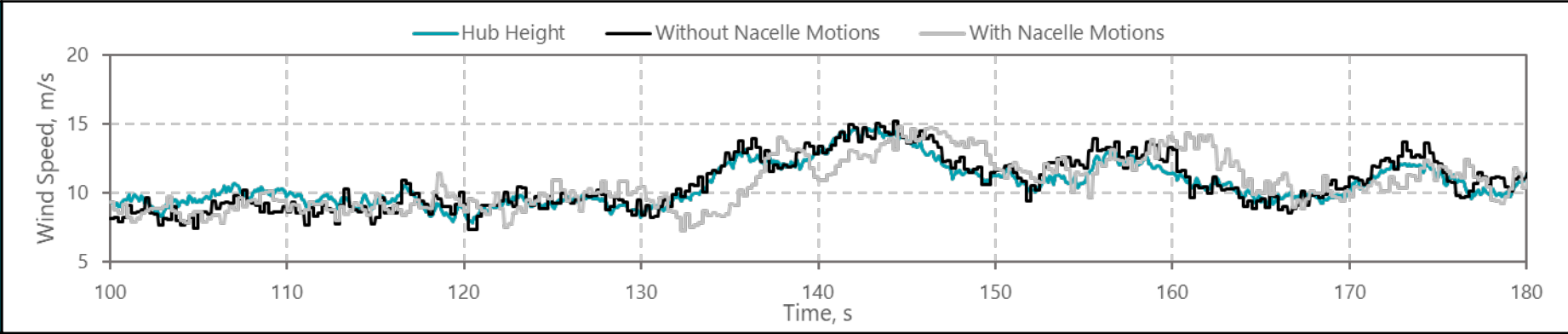

Pulsed LIDAR

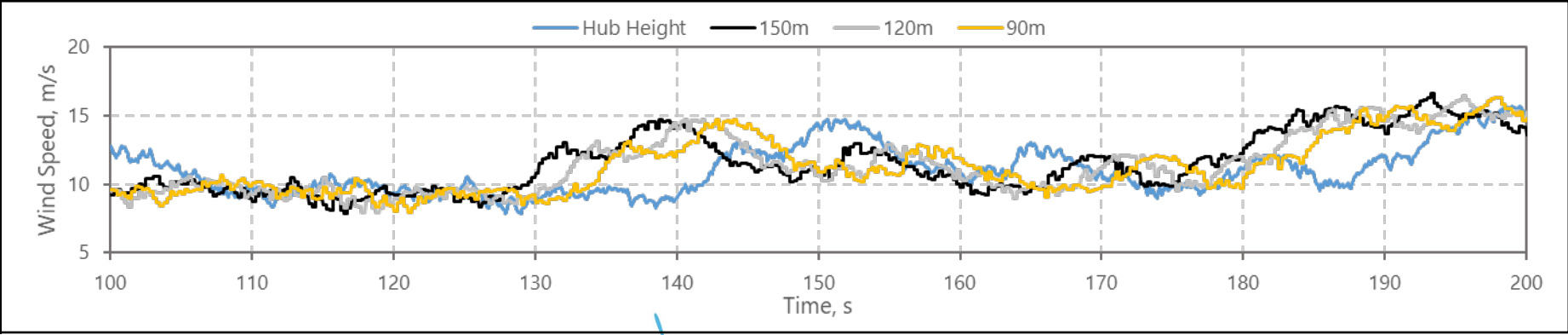

EPSRC & NERC Industrial CDT
for Offshore Renewable Energy www.idcore.ac.uk



FLOTATION ENERGY

Results

Turbulent wind field – $V_{avg} = 17 \text{ m/s}$

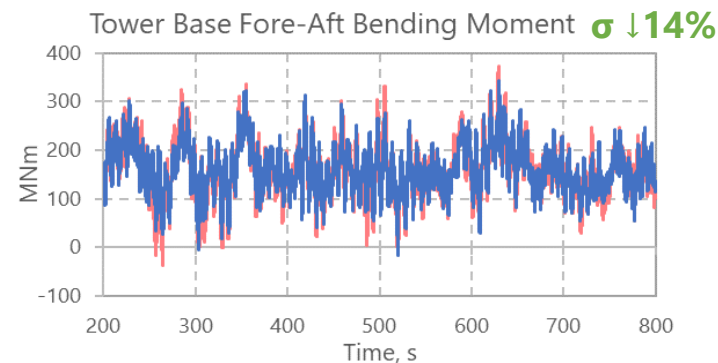
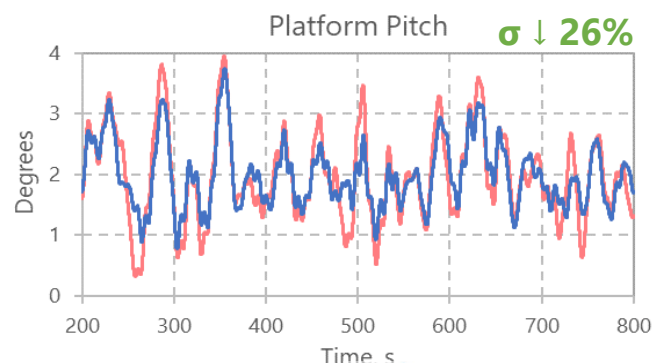
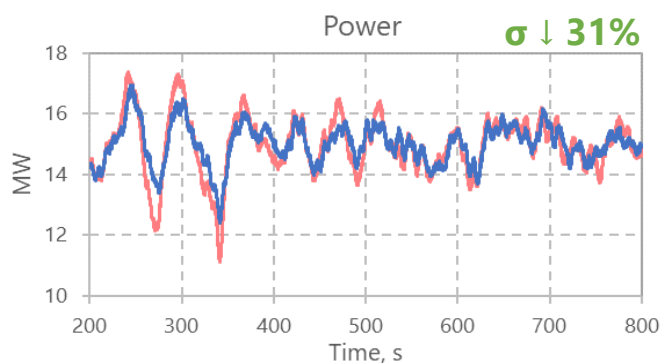
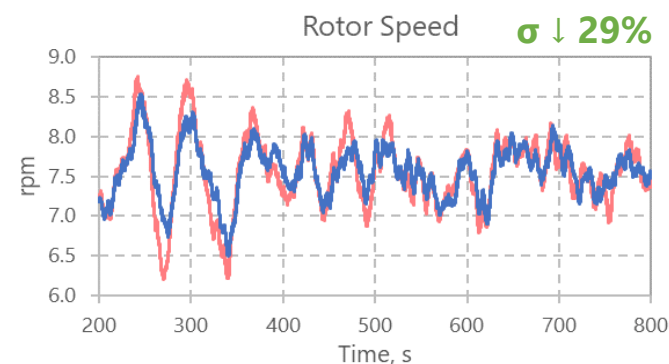
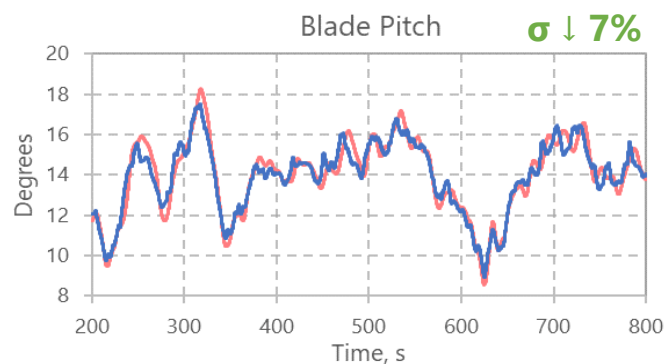
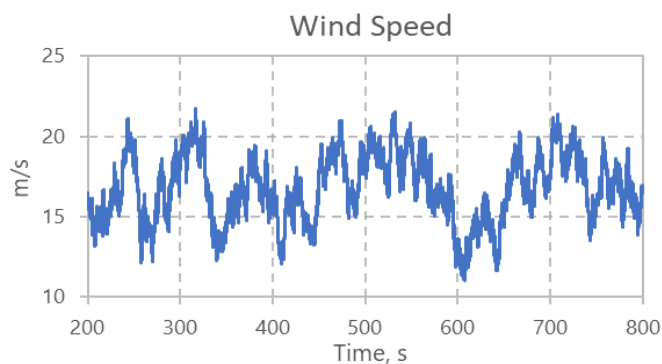

— Feedback

— Feedforward-Feedback



EPSRC & NERC Industrial CDT
for Offshore Renewable Energy www.idcore.ac.uk



FLOTATION ENERGY

Feedforward control for a 15-MW wind turbine using a spinner-mounted single-beam lidar

Wei Fu¹, Feng Guo², David Schlipf², Alfredo Peña¹ (¹DTU ²FUAS)

How helpful can a single-beam lidar be for control?

- optimizes the lidar scanning configuration for optimum wind preview;
- evaluates the control benefits using optimized lidars in aero-elastic simulations.

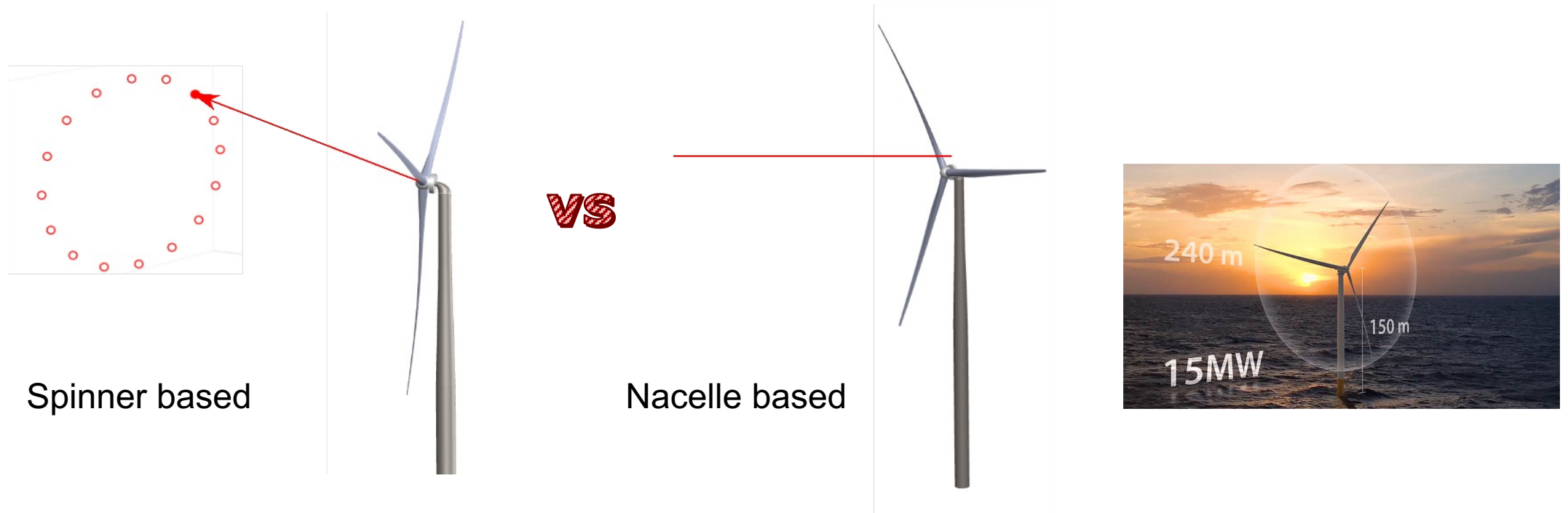

Optimization of lidar configuration (CW lidar)

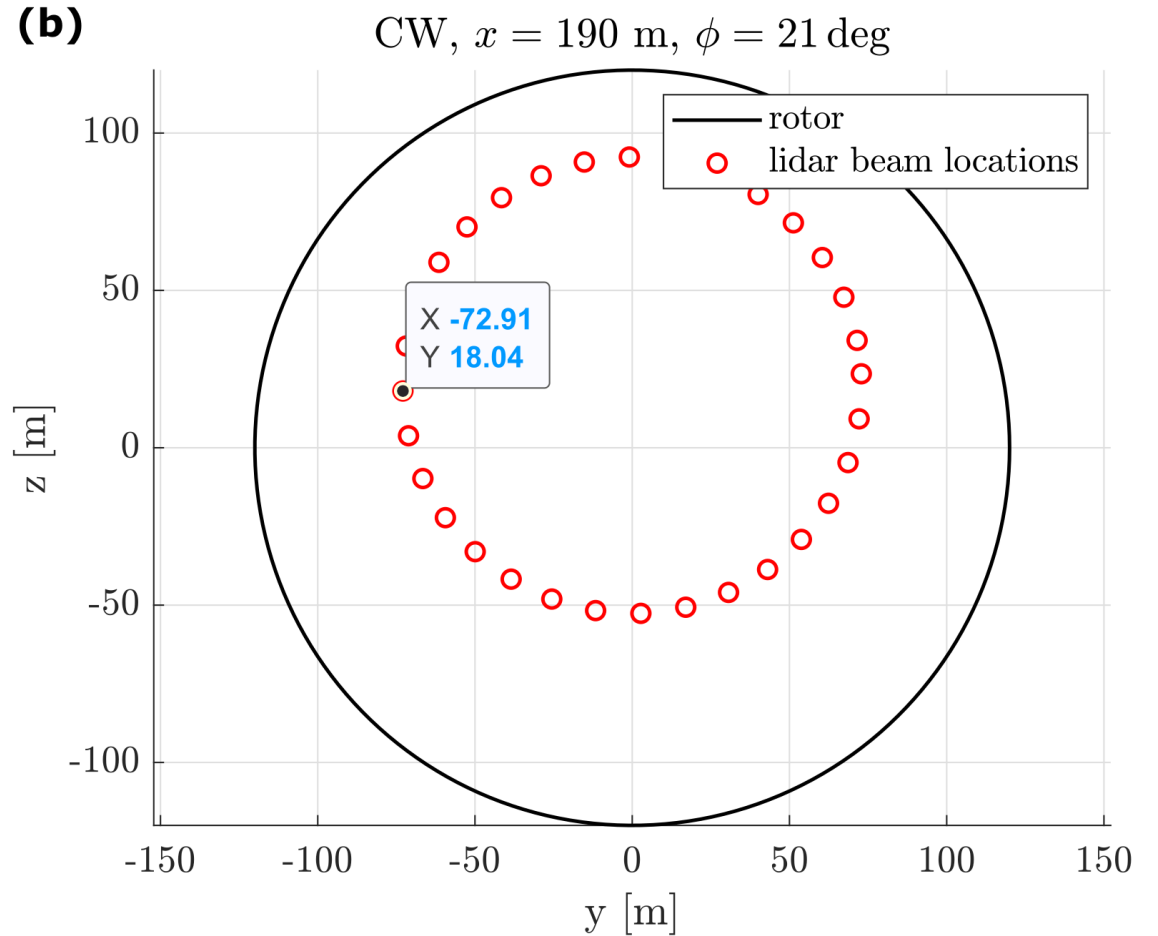
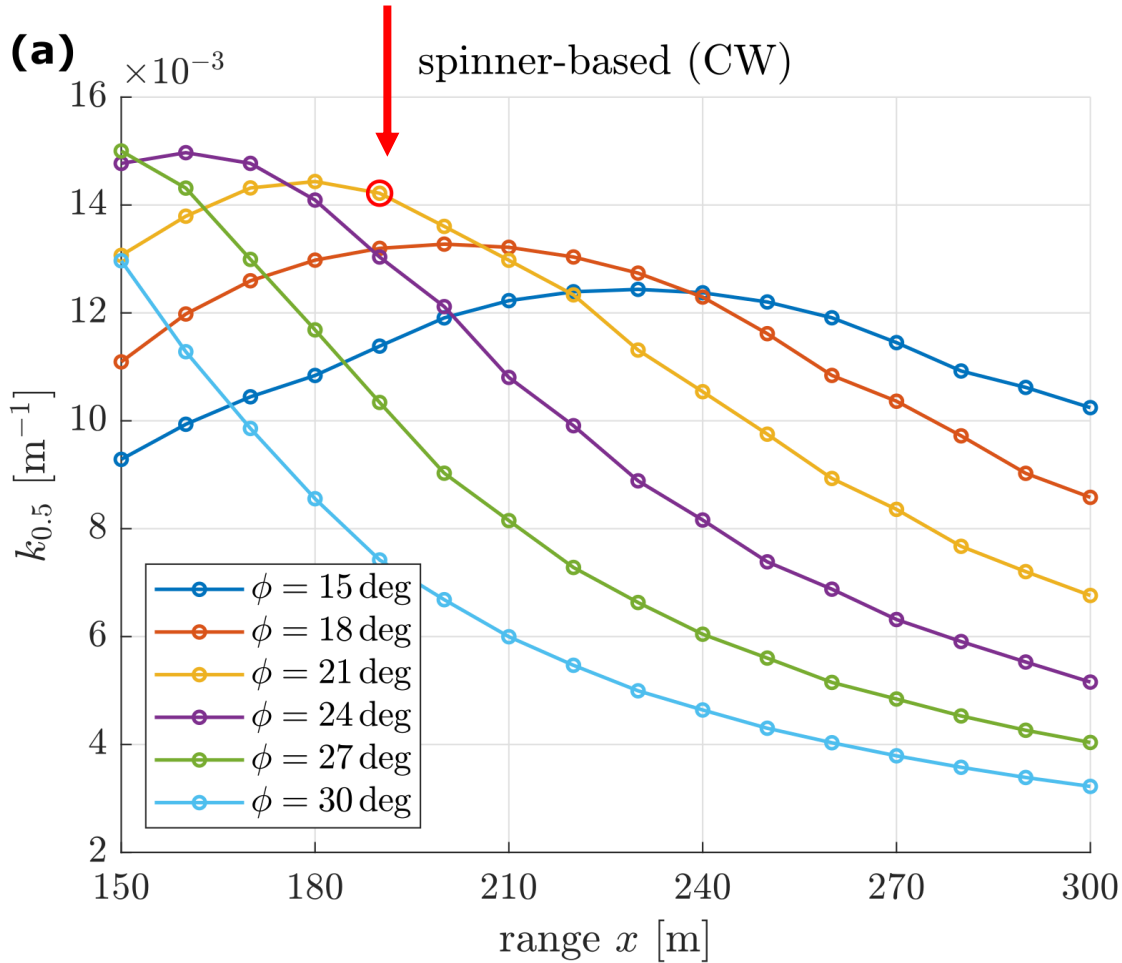

The optimized single-beam lidar in the spinner gives a much better wind preview quality than the same lidar on the nacelle.

Summary of control performances

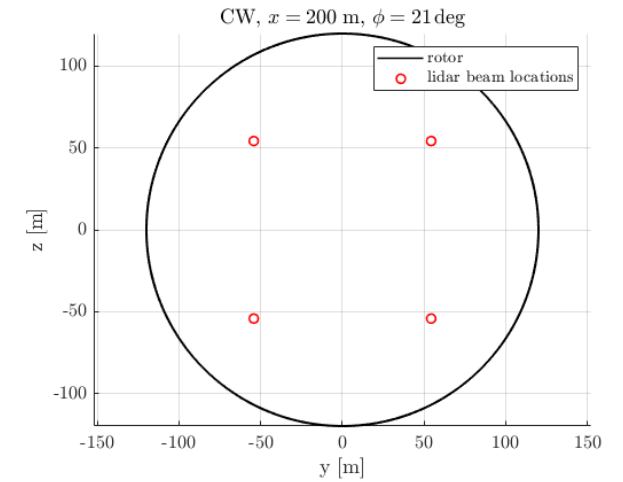
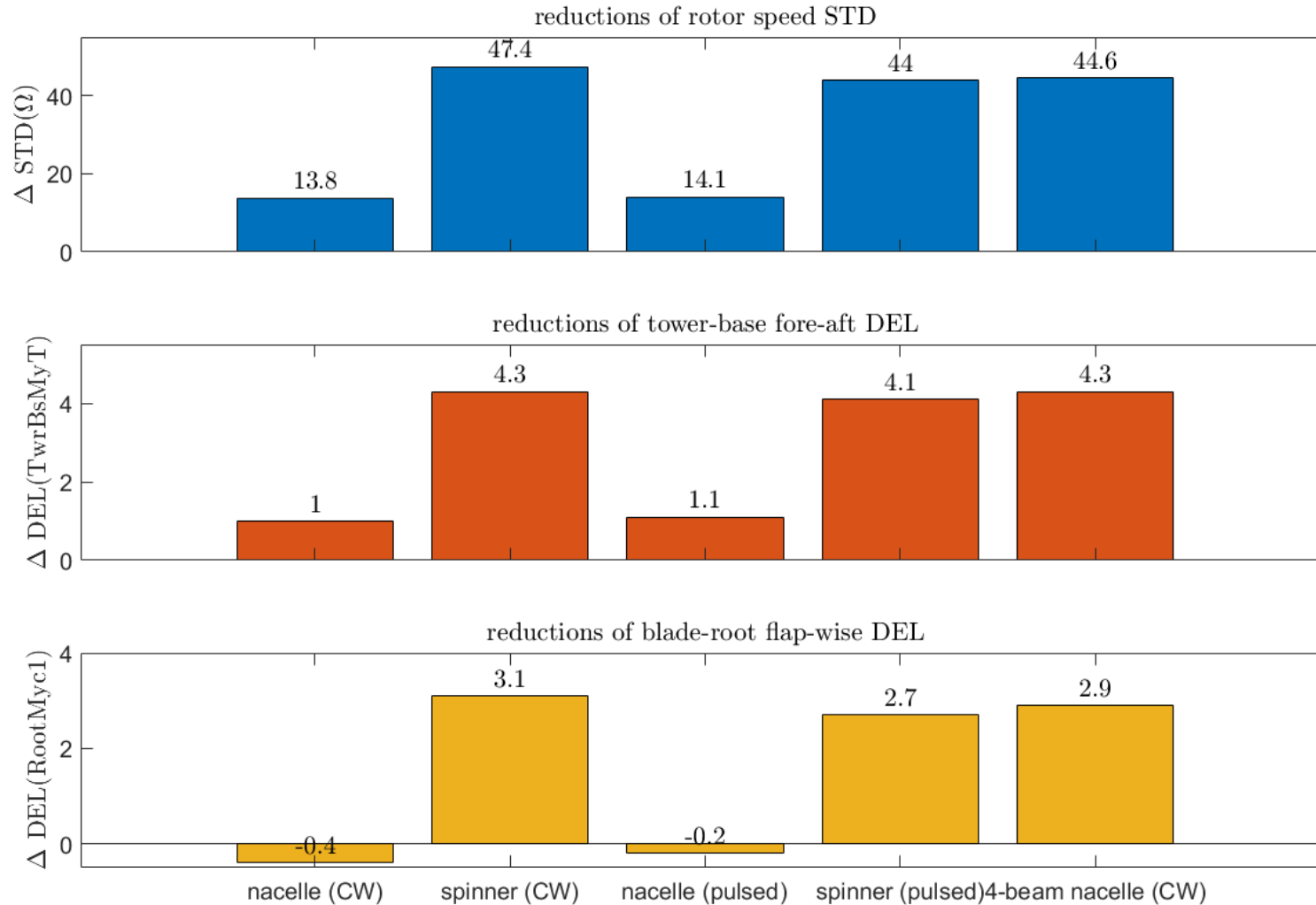

Control benefits using the optimized spinner-based single-beam lidars (CW & pulsed) are similar to the 4-beam nacelle lidar.



A data-driven approach to the design and implementation of retrofit lidar assisted control systems

Authors: Mark Pitter¹, Chris Slinger¹, Feng Guo², David Schlipf^{2,3}, Steffen Raach² and Steven White¹

¹ZX Lidars, Ledbury, UK

²sowento, Stuttgart, Germany

³Wind Energy Technology Institute, Flensburg University of Applied Sciences, Flensburg, Germany

Overview



- We report a successful and safe demonstration of load reduction using lidar assisted control (LAC) on an active stall turbine on a commercial wind farm*
- The project dimensions and commercial requirements were a test bed for concepts aimed at reducing the barriers to commercial LAC deployment
 - Utilisation of a data-driven design approach
 - Use of a simplified lidar prototype
- Baseline and lidar-assisted load measurements were aligned with design simulation predictions across a range of operational conditions.
- The prototype wind lidar was stable and flexible with performance matching or exceeding expectations

*This work is part of the 'RELACs' collaboration between RES, ZX Lidars and KK Wind Solution



Project outline

The test turbine was part of an operational wind farm in NW Europe

- 1.3 MW, fixed speed, active-stall
- Hub height 68 m, rotor diameter 62 m
- Strain gauge package was installed and signal integrated into SCADA



The design target for LAC was to reduce fatigue loads on the tower and blades with minimal impact on AEP

- Load reduction can be used to extend wind turbine lifetime and hence reduce LCOE

Safety and verification were paramount throughout the design, test and implementation phases

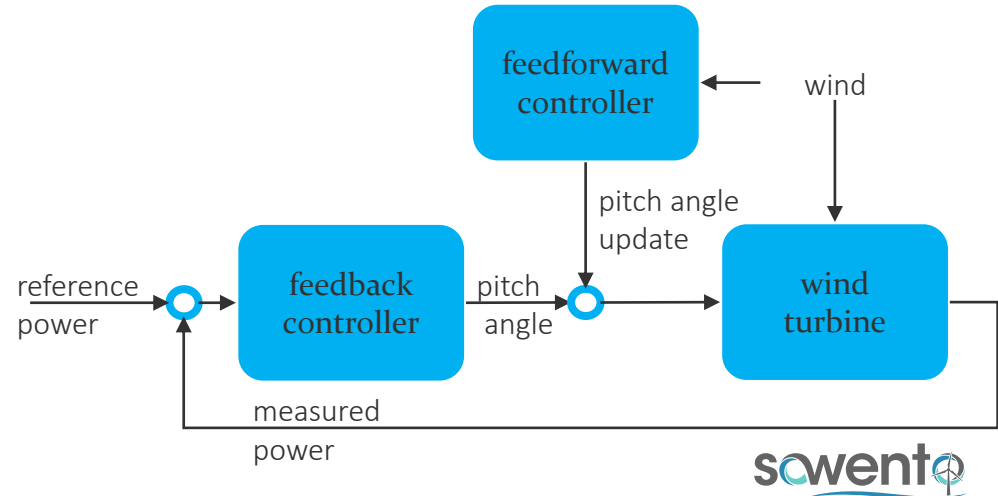

Simplified Low Order Wind (SLOW) turbine model

$$J\dot{\Omega} = M_a - M_G$$
$$m\ddot{x}_T + c\dot{x}_T + kx_T = F_a$$

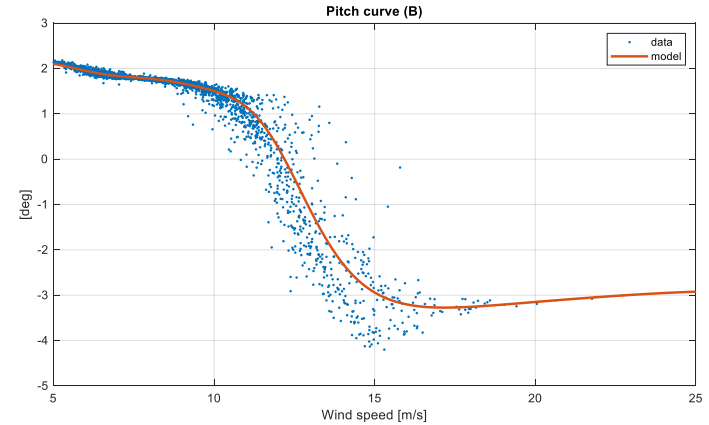
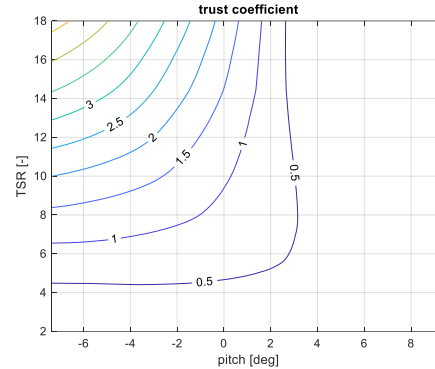
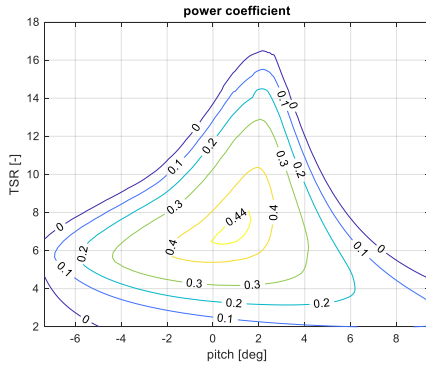

- Reduced rotor and tower motion model
- Parameters from basic data (e.g. tower top mass, rotor radius)
- Use of LM29 Blade designed for Stall-regulated turbines
- Aerodynamic properties with Qblades from NACA airfoils and public report
- Adjustment of pitch vector to fit to data

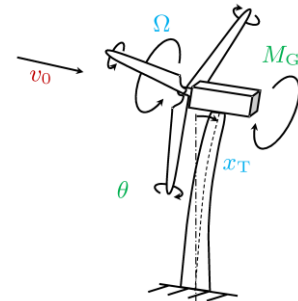

<https://d-nb.info/1118369653/34>

Operation of Activation Block

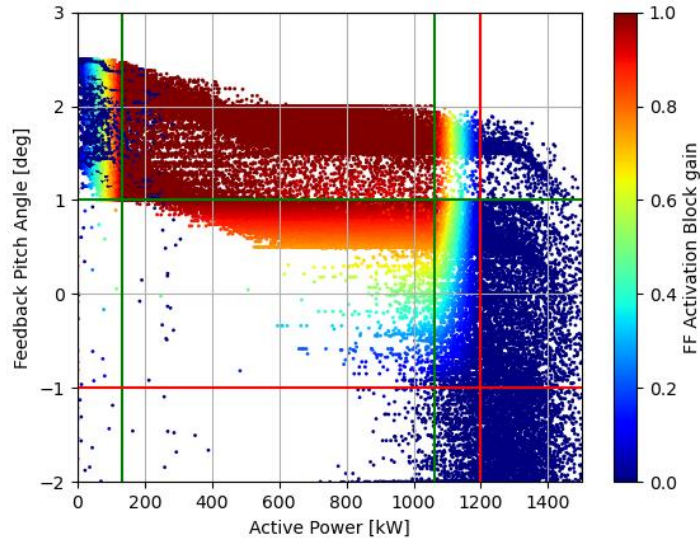

- The plot illustrates the Activation Gain block
 - FF gain fades out for active power below 10% and above 80% of rated power and for (FB) pitch angles less than $+1^\circ$
 - Active stall blade dither is clearly visible
- (The blue dots at low active power are from periods of small generator operation where LAC was disabled)

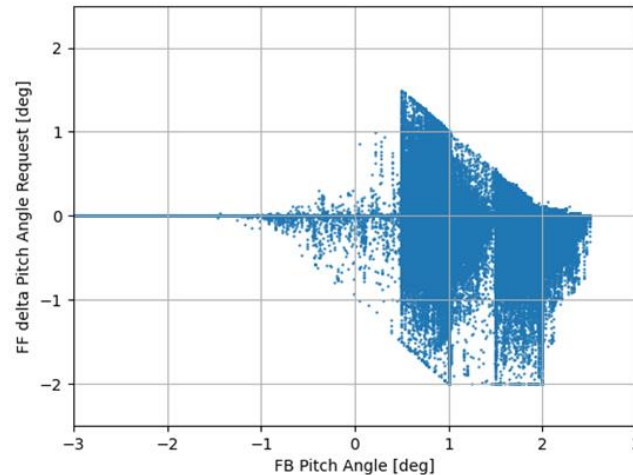

Results

The LAC scheme was “toggle-tested” with a 50-minute interval to best match atmospheric and turbine operation state for “LAC on” and LAC “off” periods

Strain gauge data was processed to extract fore-aft tower base bending moments

The resulting data was inspected as spectra and processed with the rain flow algorithm to calculate Damage Equivalent Load (DEL)

An early result demonstrated qualitative agreement between model and measurements and that LAC was having a positive effect

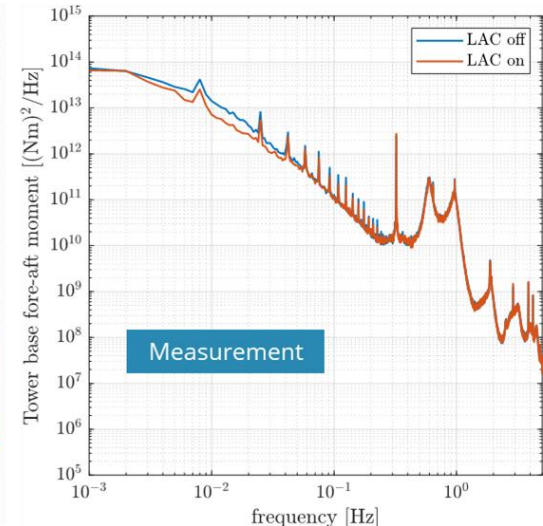
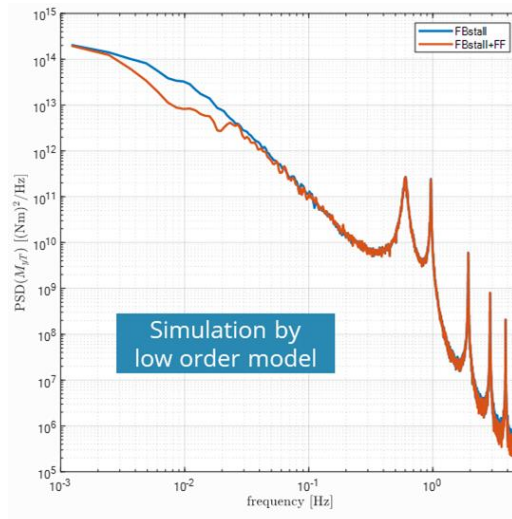

Histogram of Tower Base Damage Equivalent Load

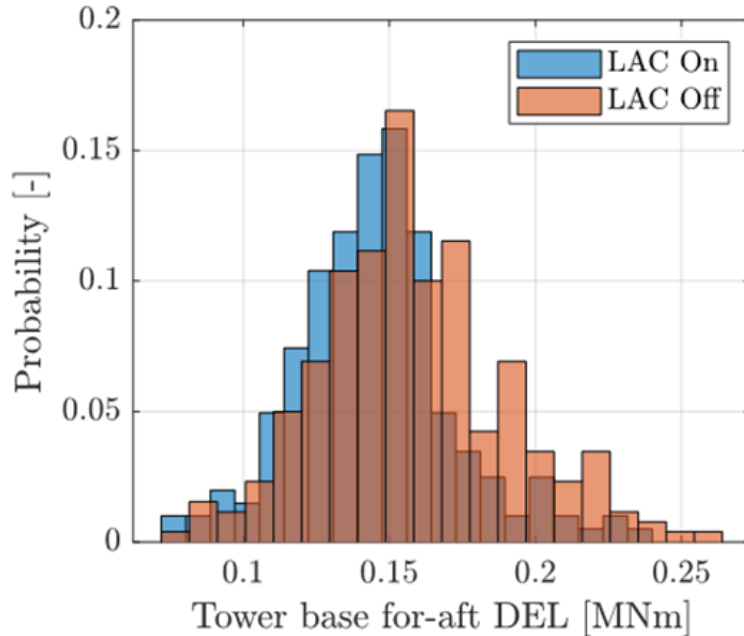

Overlapping histograms of DEL for each 1,000-second period clearly illustrate the DEL reduction when LAC is applied

Provisionally estimated DEL reduction of 8.6% for wind speeds between 7 and 10 m/s

Using scanning lidar data to predict future wind flows

W.P. Engels and R. Rotteveel

WESC 2023 Glasgow

What are we trying to predict?

A short term prediction of *the flow in a wind farm*

- Based on scanning lidar measurements
- Each scan: 3 elevations (2.4°, 4.8°, 7.2°), 20 azimuths, 80 ranges (25m each), ~2 min interval

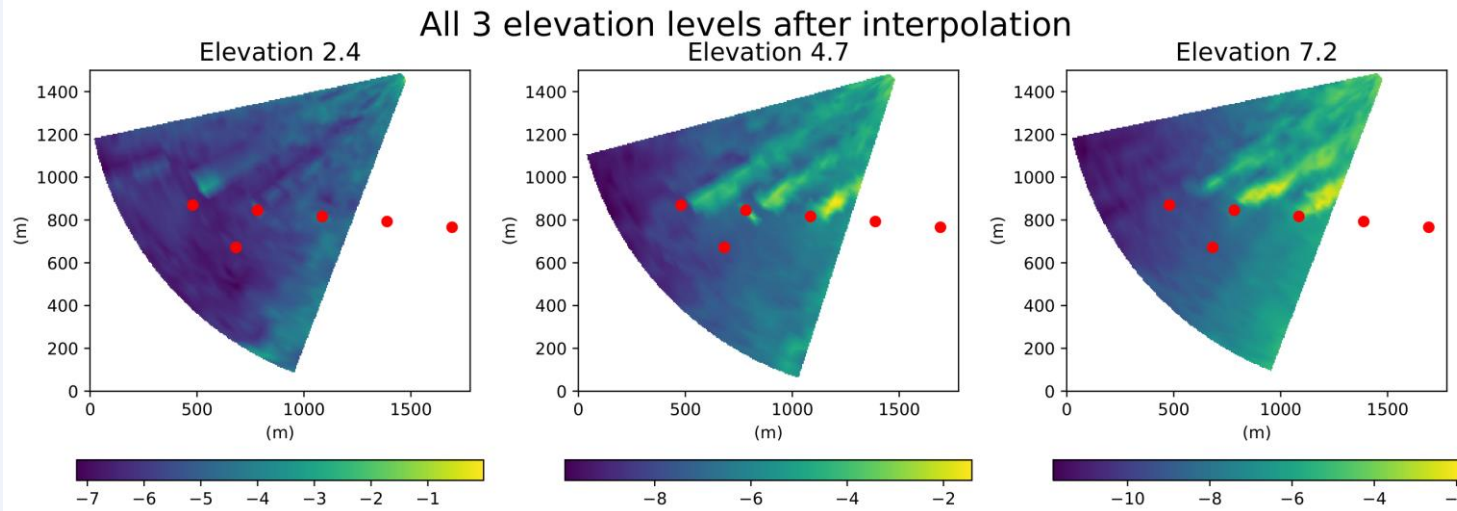

What are we trying to predict?

A short term prediction of the flow in a wind farm

- The flow in a wind farm, in particular: wakes
- Completely data driven
- Based on previous 5 scans: predict the next 5 scans

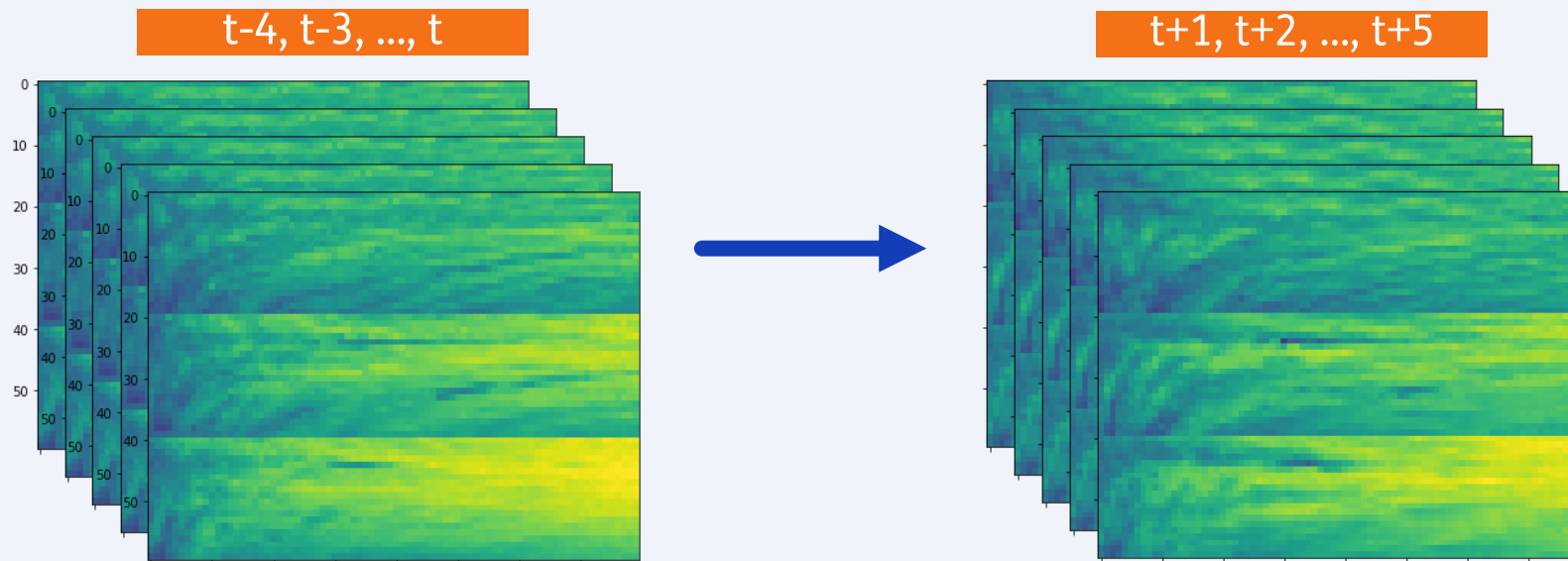

Why a short term prediction?

To use as part of wind farm control systems:

- Production prediction
 - Information for grid support/trading
- Wind farm control
 - Wake steering
 - Power/load distribution/hybrid power plants

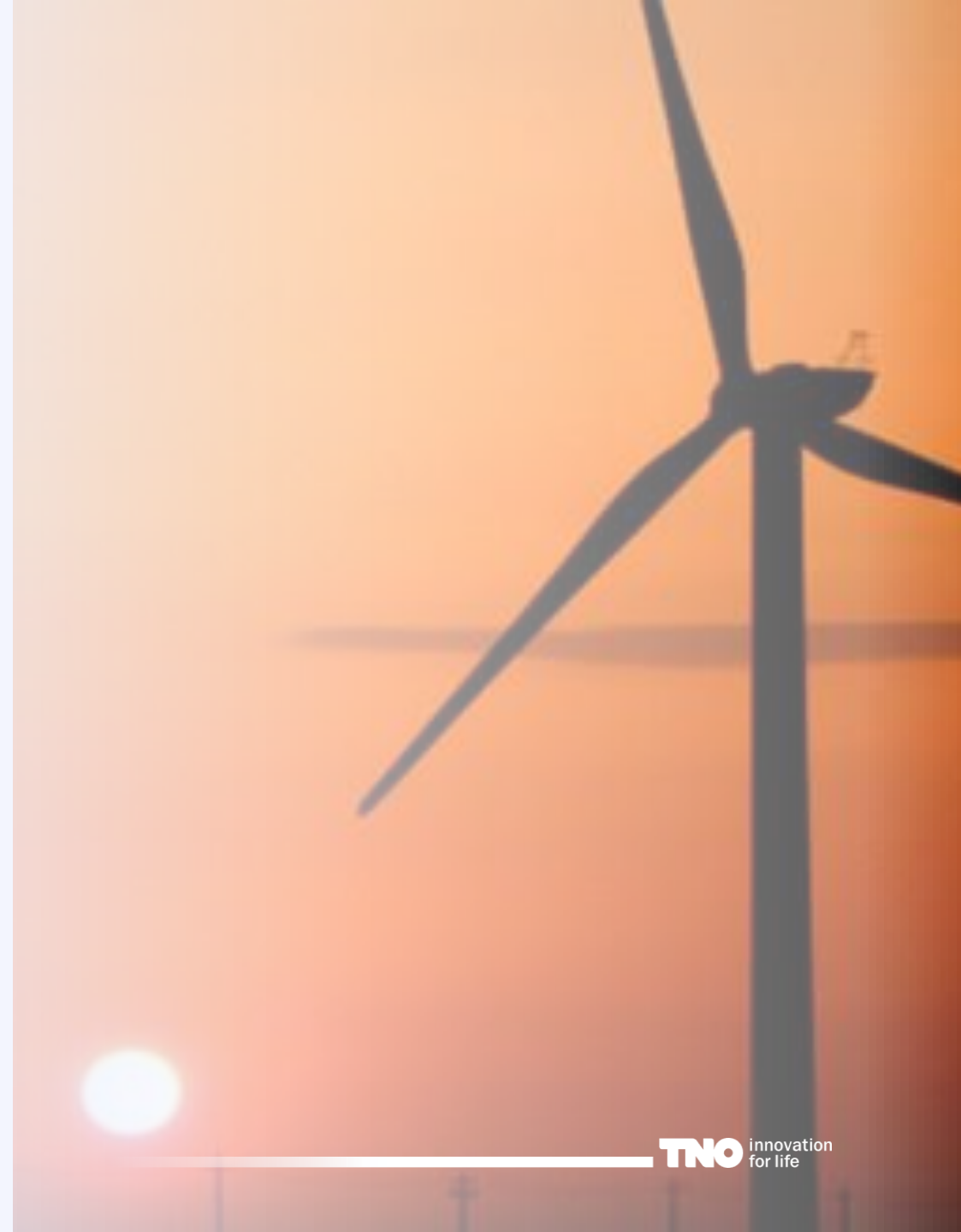
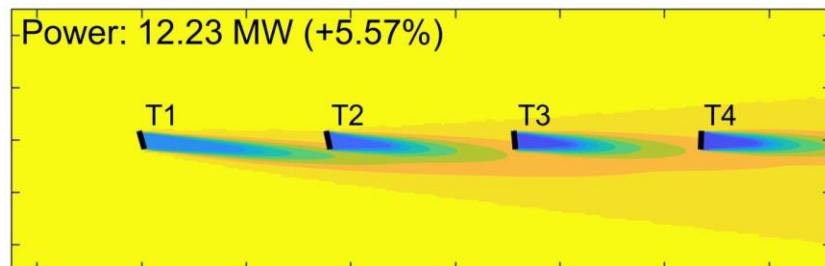
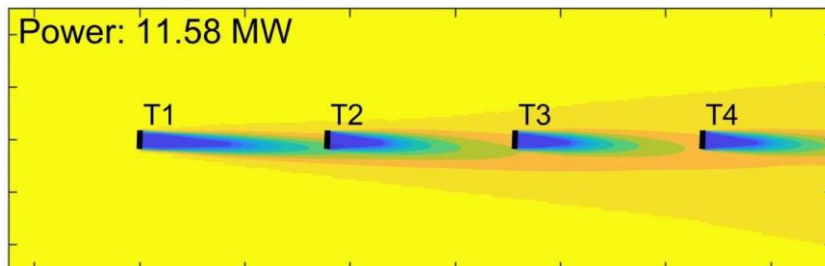

How do we make a prediction?

- Deep(ish) Artificial Neural Network with time component
- Encoder-decoder-like structure
 - Limits the data flowing through the network
- LSTMs used at bottle-neck
- Training on a single machine equipped with an Nvidia A100/40GB card

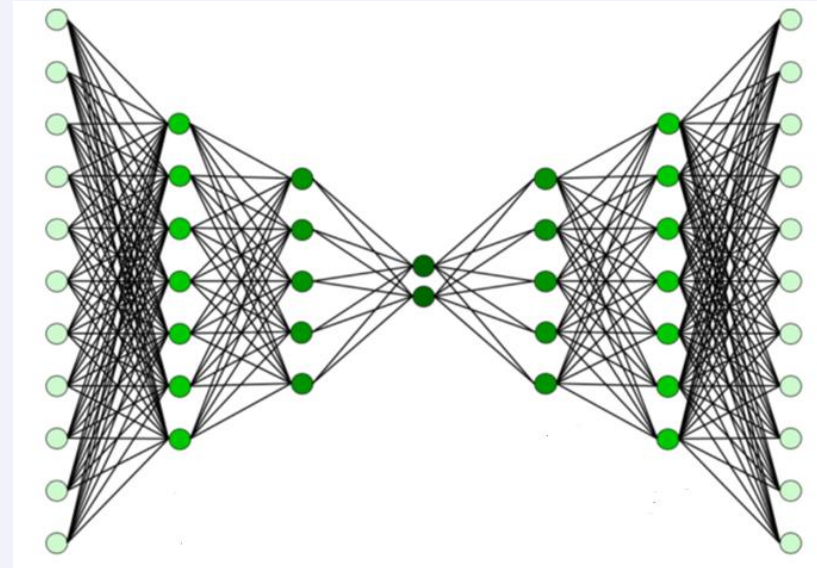

How do we make a prediction?

- Data acquired at EWTW test site
- Site configuration at the time
 - Top row (partly) in view
 - Bottom row of prototypes (disturbed inflow)
 - Main wind direction SSW
- Range up to 3km

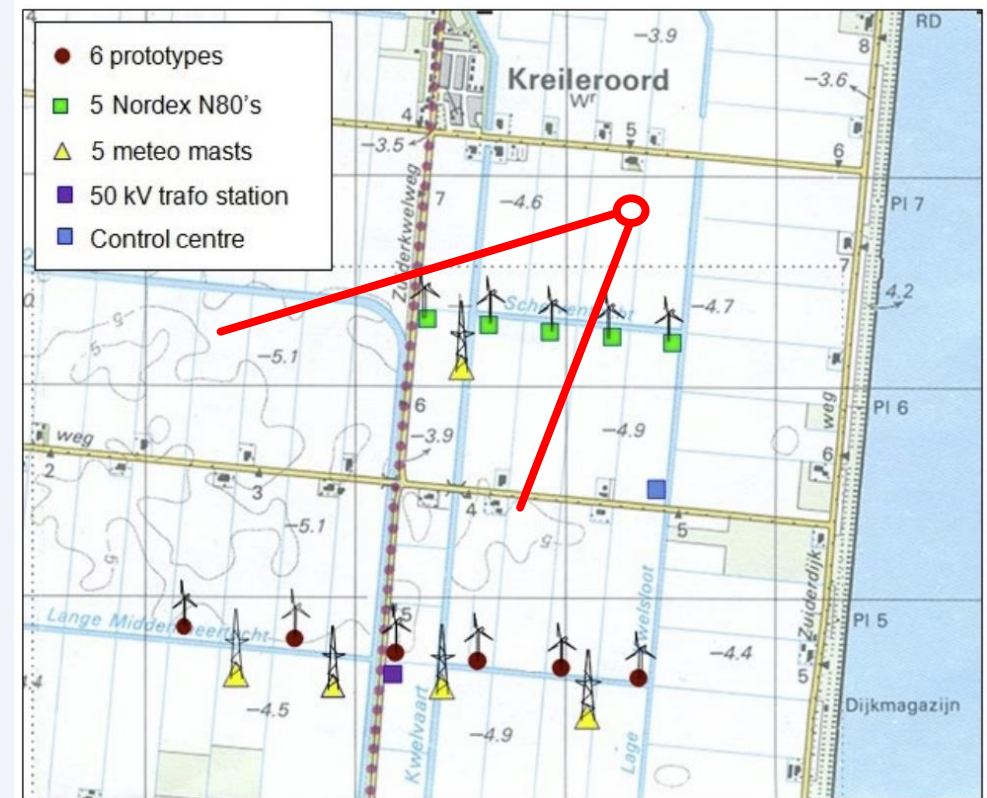
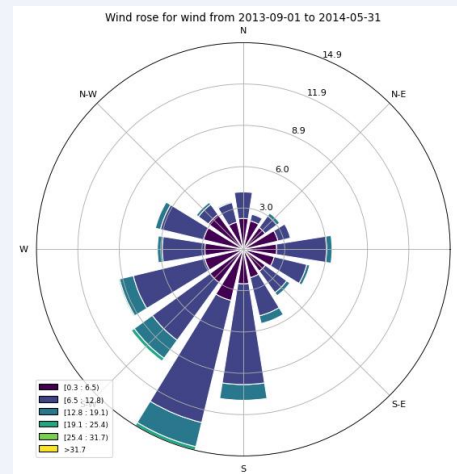

Results

- Typical prediction
- Wakes + mean windspeed are predicted well
- Note: wind speed along LoS
- North Easterly wind

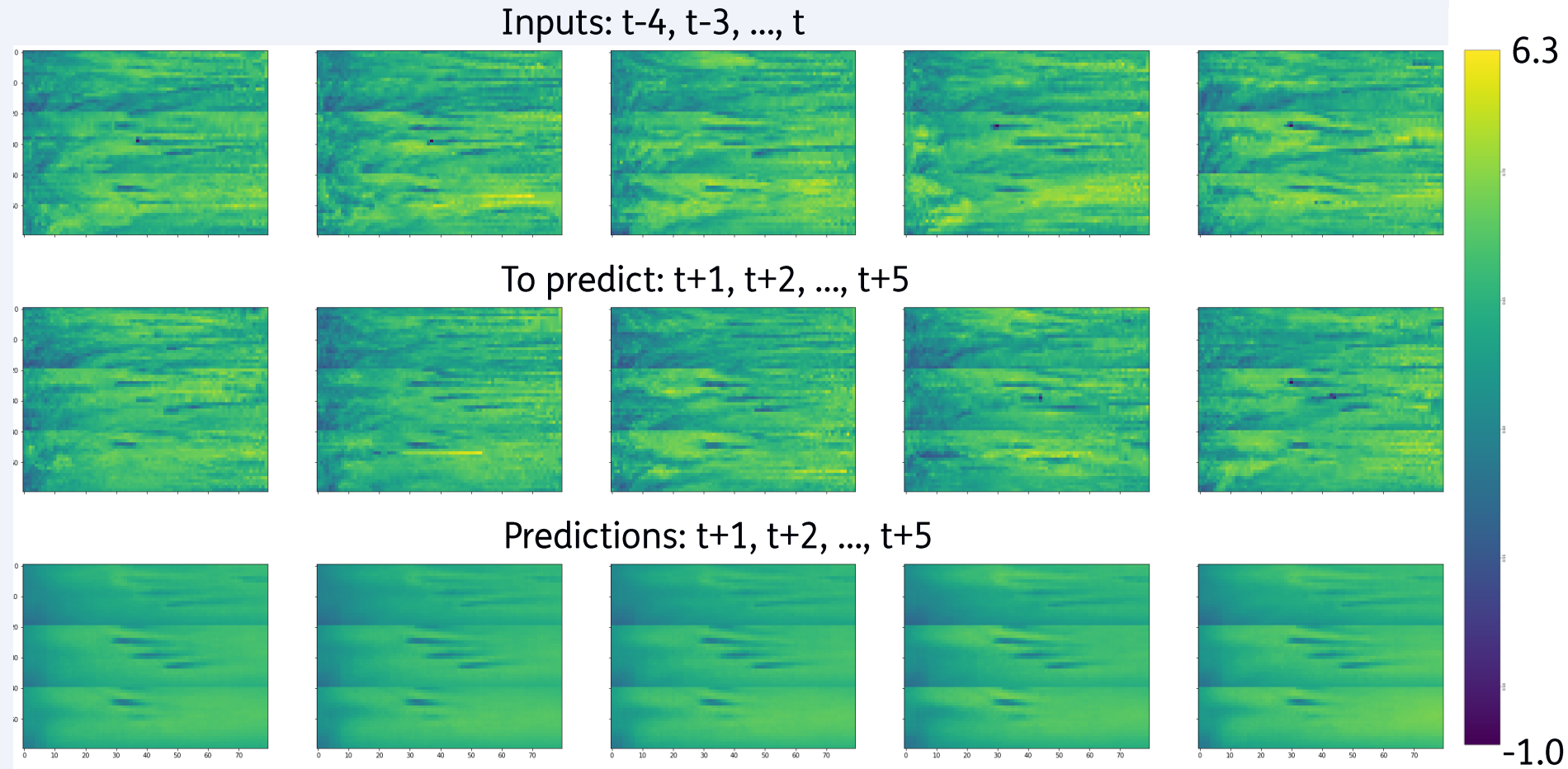



WHEN TRUST MATTERS

Assessment of measurement-data from nacelle-based Lidar-devices regarding their usability for the estimation of turbulence intensity

Presentation for WESC Glasgow 2023

Jakob v. Eisenhart Rothe MSc. Project Engineer Lidar & Power Performance

18 April 2023

LOS TI from 4-beam pulsed Lidar

$$TI_i = \sqrt{\frac{\sum (RWS_i - \overline{RWS_i})^2 * Status_i}{\sum Status_i}} \cdot \frac{1}{|\overline{RWS_i}|}$$

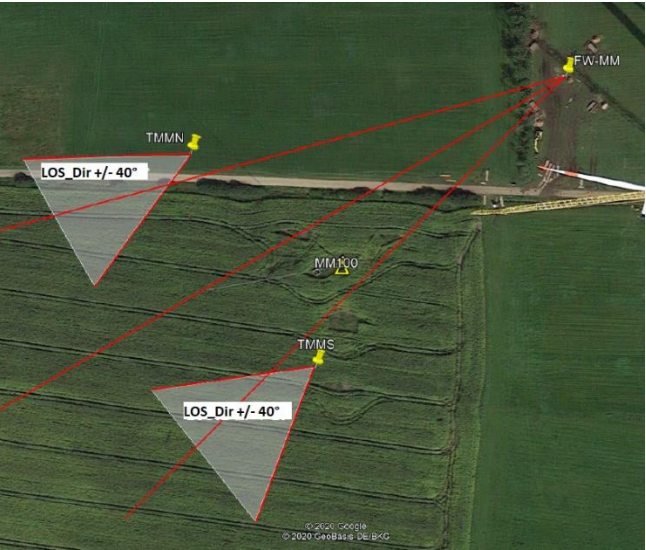
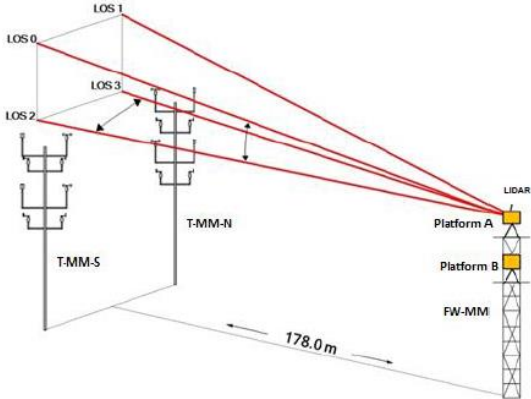

Results

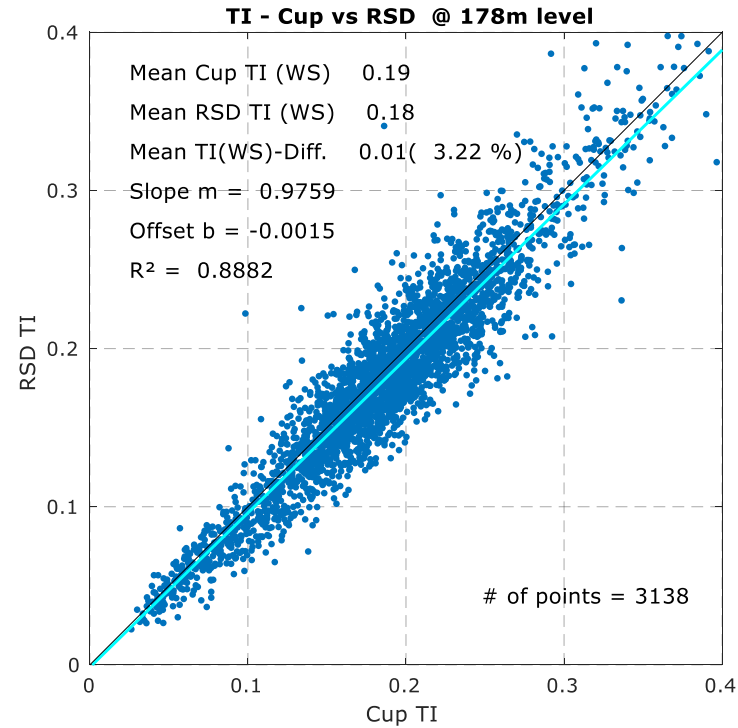
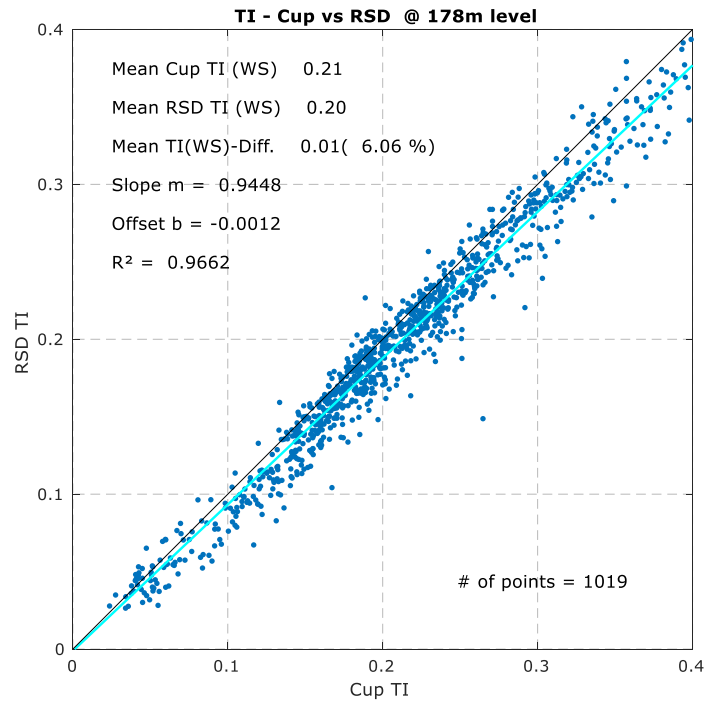

- Underestimation from Lidar through whole spectrum (more or less constant)
- Overall quite good correlation

Black box comparison

- $Tl_{ref} = \frac{USA_{HWS,10min}}{\sigma_{HWS,10min}}$
- $Tl_{low} = \frac{Tl_{LOS2} + Tl_{LOS3}}{2}$

- Overestimation from lidar

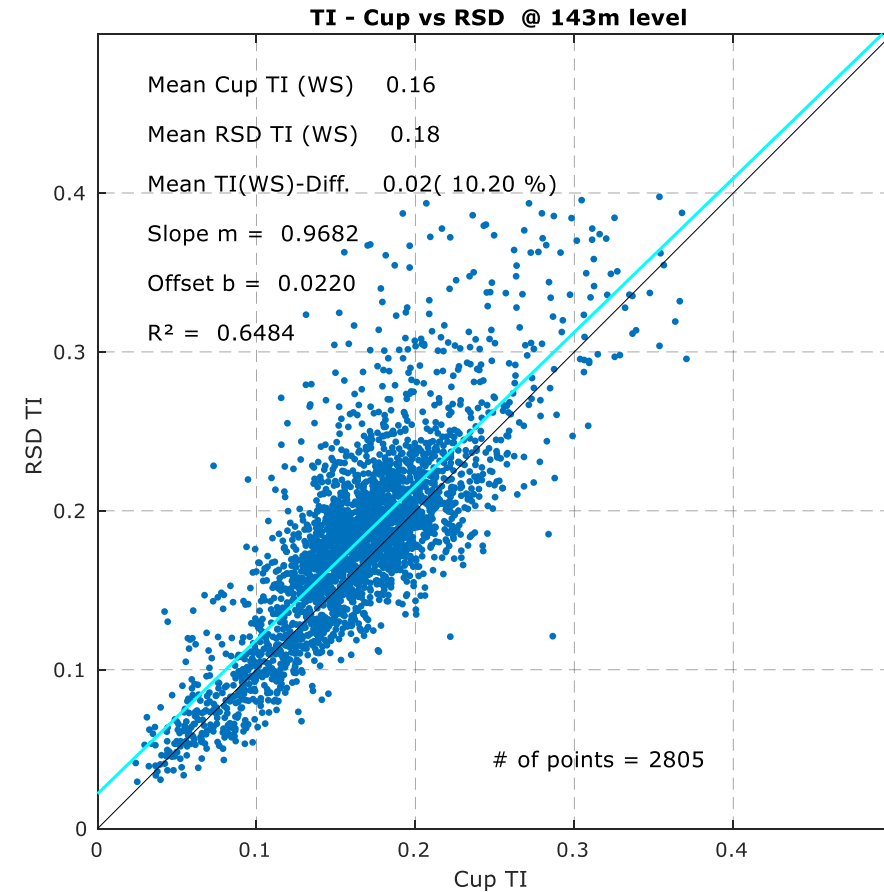
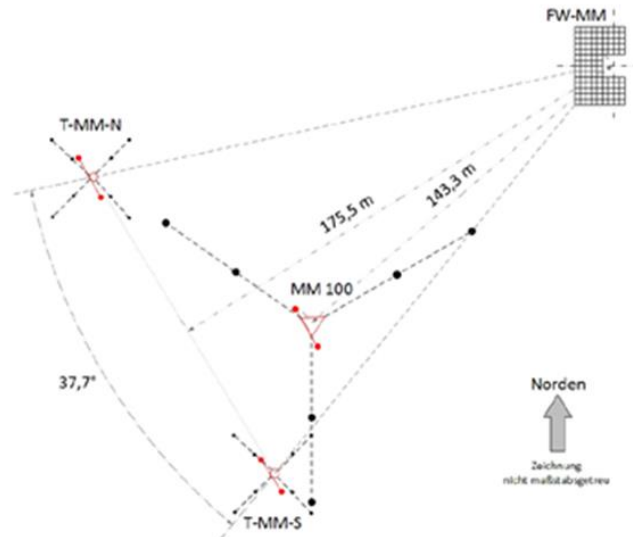

LOS TI from Continuous Wave Lidar

- $$RWS_{\vartheta \pm 1^\circ, 10min} = \frac{\sum_{i=0}^{n(10min)} RWS_{\vartheta \pm 1^\circ, 48.8Hz}}{n(10min)}$$
- $$TI_{CWlidar} = \frac{\sigma RWS_{\vartheta \pm 1^\circ, 10min}}{RWS_{\vartheta \pm 1^\circ, 10min}} [\%]$$

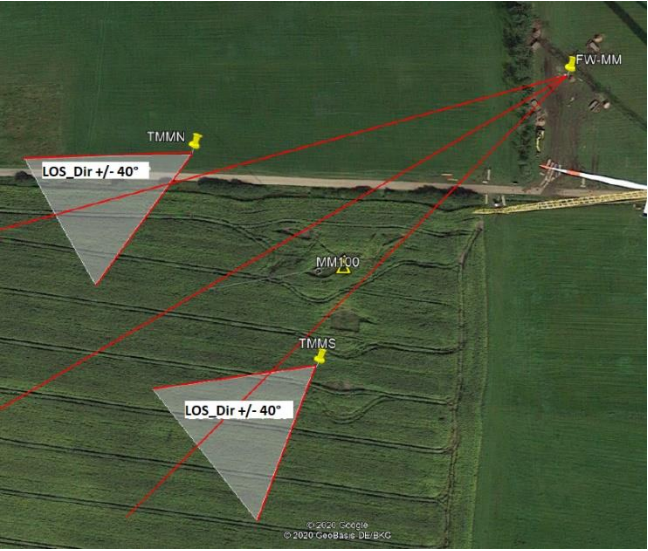
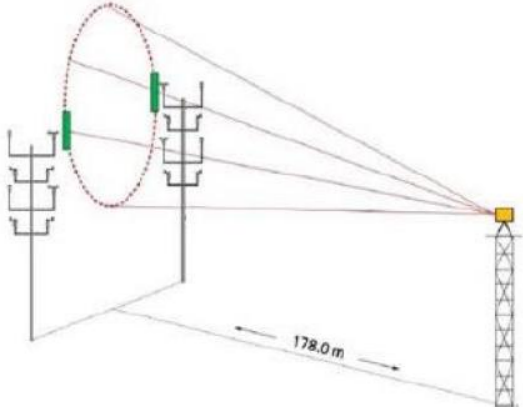

Results

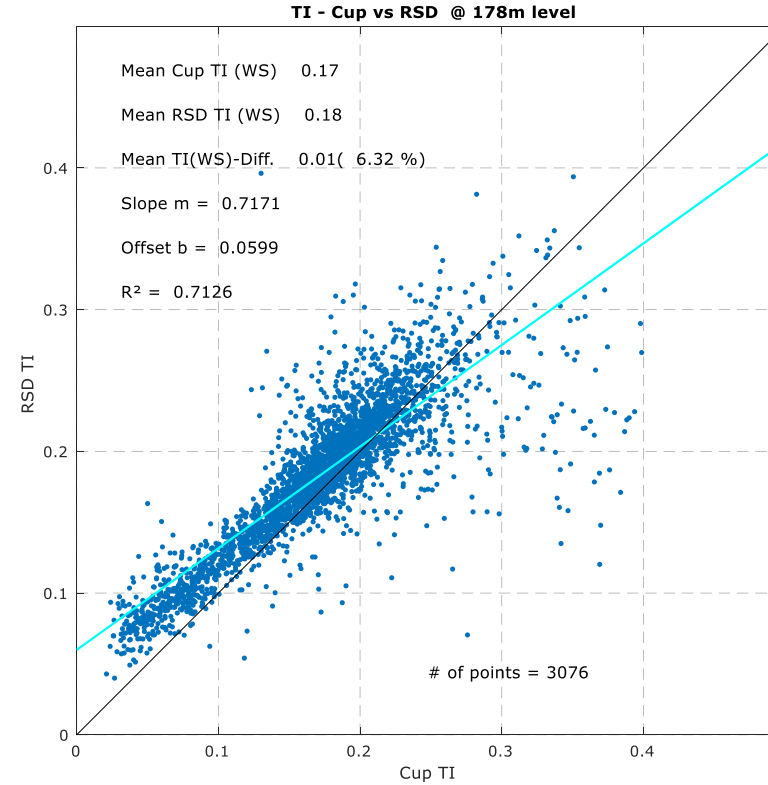
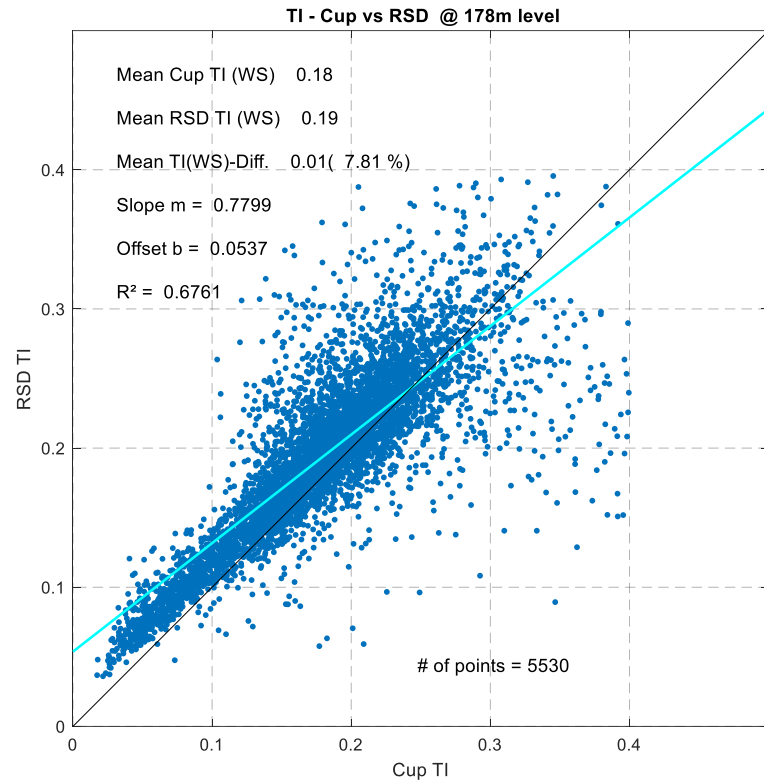

- overestimation from Lidar for lower TI
- smaller overestimation for higher TI

Comparison of TI from North and South Mast

- Mean TI is more or less equal
- High scatter through whole spectrum of TI
- WD filtered 195° to 275°

