

PROCEEDINGS OF SPIE

SPIDigitalLibrary.org/conference-proceedings-of-spie

Design and development of PhLEXSAT – a flexible photo-digital communication payload for very high throughput satellites

Madhubrata Chatterjee, Chiara Palla, Edem Fiamanya,
Steve Legate, Antoni Castells Cervello, et al.

Madhubrata Chatterjee, Chiara Palla, Edem Fiamanya, Steve Legate, Antoni Castells Cervello, Laurent Roux, Marta Beltran, Miguel Angel Piqueras, Patrick Runge, Nigel Cameron, Jakub Zverina, "Design and development of PhLEXSAT – a flexible photo-digital communication payload for very high throughput satellites", Proc. SPIE 12777, International Conference on Space Optics — ICSO 2022, 127773I (12 July 2023); doi: 10.1117/12.2690526

SPIE.

Event: International Conference on Space Optics — ICSO 2022, 2022,
Dubrovnik, Croatia

International Conference on Space Optics—ICSO 2022

Dubrovnik, Croatia

3–7 October 2022

Edited by Kyriaki Minoglou, Nikos Karafolas, and Bruno Cugny,



Design and Development of PhLEXSAT – A Flexible Photo-Digital Communication Payload for Very High Throughput Satellites



International Conference on Space Optics — ICSO 2022, edited by Kyriaki Minoglou, Nikos Karafolas, Bruno Cugny, Proc. of SPIE Vol. 12777, 127773I · © 2023 ESA and CNES · 0277-786X · doi: 10.1117/12.2690526

Proc. of SPIE Vol. 12777 127773I-1

Design and Development of PhLEXSAT – A Flexible Photo-Digital Communication Payload for Very High Throughput Satellites

Madhubrata Chatterjee^a, Chiara Palla^{a*}, Edem Fiamanya^a, Steve Legate^a, Antoni Castells Cervello^b, Laurent Roux^b, Marta Beltran^c, Miguel Angel Piqueras^c, Patrick Runge^d, Nigel Cameron^e, Jakub Zverina^f

^a MDA, United Kingdom, ^b Eutelsat, France, ^c DAS Photonics S.L., Spain

^d Fraunhofer – Institut für Nachrichtensysteme, Heinrich-Hertz-Institut (HHI), Germany

^e Axenic, United Kingdom, ^f Argotech, Czech Republic

*Corresponding Author: chiara.palla@mdaspace.uk

ABSTRACT

Cost of in-orbit capacity is an important element to take into account when ordering new satellites in order to remain competitive with terrestrial-based solutions. This can be achieved by minimizing the size, weight, and power consumption (SWaP), volume, reducing spacecraft AIT, etc. Properties of photonics components makes them a natural candidate while designing future generation Satcom payloads.

Photonic components offer the advantage of minimizing the SWaP of satellite communication payload and are capable of offering a limitless bandwidth in THz range at around 1550 nm wavelength. Light weight and low volume photonic components offer almost lossless propagation in an optical fibre within a spacecraft and immunity to Electromagnetic Interference (EMI).

With the advancement of photonic technology, it is now possible to develop Tbps-like software defined photonic payload of high data rates and frequencies with almost lossless propagation in an optical fibre. However, at present in the satcom industry only a few demonstrations of photonic devices in non-critical equipment with limited degree of integration can be found.

This paper presents a space-based photo-digital communication payload called PhLEXSAT and shows how the advantages offered by photonics can be utilized in increasing the capacity of Very High Throughput Satellites (VHTS) while reducing the cost at the same time.

PhLEXSAT is a Ka/Q/V/W band communication system that will use novel optical devices for space-based systems, these are currently under design and development stage. The architecture incorporates advanced broadband photonic ADC and photonic DAC with digital processing firmware with a high degree of miniaturization and power-consumption efficiency. This design will be suitable for future Terabit per second satellites.

PhLEXSAT project is focusing on the advancement of these key photonic technologies to develop a photo-digital channelizer for flexible HTS. PhLEXSAT project, funded under the European Union H2020 programme, is led by DAS Photonics in cooperation with MDA UK, Eutelsat, Axenic, HHI Fraunhofer and Argotech.

Keywords: Digital Signal Processing, Photonics, Satellite Communication, VHTS, Terabit

Acronyms/Abbreviations

ADC	Analog to Digital Converter
AIT	Assembly, Integration, Testing
DAC	Digital to Analog Converter
GW	Gateway
HL-PD	High Linear Photodetector
HTS	High Throughput Satellite
LEO	Low Earth Orbit
MZI	Mach-Zehnder Interferometer
PIC	Photonic Integrated Circuit
S/C	Spacecraft
SoA	State of the Art
SWaP	Size, Weight, and Power consumption
TDP	Transparent Digital Processor
TRL	Technology Readiness Level
VHTS	Very High Throughput Satellite

1. INTRODUCTION

Cost of in-orbit capacity is an important element to consider while designing a satellite mission. Cost can be lowered by minimizing the SWaP, volume, reducing spacecraft AIT, etc. Naturally, while designing future generation Satcom payloads, photonic components become a natural candidate because of their properties like light weight and low volume which offer a lower SWaP. Photonics also offers an exploitable capacity in THz range and limitless bandwidth at the band around 1550 nm while giving almost lossless propagation in an optical fibre within a spacecraft and immunity to Electromagnetic Interference (EMI).

PhLEXSAT H2020 project is focusing on the advancement of key photonic technologies to develop a photo-digital channelizer for flexible high throughput SATCOM applications. PhLEXSAT consortium members comprises of equipment manufacturer DAS Photonics S.L (Spain), satellite integrator MDA (United Kingdom), satellite operator and end user Eutelsat (France), component foundry Fraunhofer – Institut für Nachrichtensysteme, Heinrich-Hertz-Institut (HHI) (Germany), component manufacturer aXenic (United Kingdom) and assembly and packaging company Argotech (Czech Republic).

Photonic circuits are beneficial in some of the microwave functions like frequency generation, frequency conversion, beamforming, RF filtering, etc. [1]. Fibre Optic Gyroscope, which flew onboard the Planck scientific satellite (2005), used optical waves propagating in a fibre-optic coil to accurately measure a rotation rate. The fibre-optic coil was resilient to temperature changes, magnetic perturbations, extreme shock, and vibrations.

Soil Moisture Ocean Salinity (SMOS) (2009) demonstrated the first operational use of fibre-optics communication links. PROject OnBoard Autonomy (Proba-2) (2009) contained a fibre sensor-system to monitor temperature and tank pressure within the satellite propulsion system, marking the first full fibre-optic sensor network in space.

The design, development, and breadboard of a high-capacity optical interconnect solution (TAS's DTP 2nd generation) has been presented by [2]. The design presents a solution of using 1000 fibre links at 10 Gbps each linked with an optical interconnection flexible plane to reach 1 Tbps capacity. It uses high-speed serial links with fibre-optic interconnects instead of coaxial cables.

OPTIMA H2020 project studied that photonic technology can offer a mass reduction of up to 25% compared to the conventional payload technology by replacing co-axial cables with fibre-optic cables. A preliminary estimate of the mass and power consumption for the OPTIMA payload demonstrator, consisting of only optical equipment with RF input and output interfaces, shown a mass of 8.5 kg and power consumption of 54.5 W. ESA targets power consumption of <10mW/Gbps i.e.: <100 W for 10 Tbps [3].

2. MISSION SCENARIO

In this section we define, from mission operator perspective, a scenario where PhLEXSAT can give substantial benefit in terms of flexible throughput for next generation satellite telecom payloads. Two mission scenarios have been proposed to study the benefits of using photonics vs RF-only solution in the repeater implementation. One of the main conclusions from the previous studies, [4] [5] [6], is the reduction of size, weight and power (SWaP) provided by photonics solution. Two candidates which could exploit this advantage include:

- Very High Throughput Satellite (VHTS)
- Direct To Home (DTH) Satellite using active antennas

These two types of missions would require large number of RF units, making the reduction in SWaP, and therefore mission price, an attractive prospect from an operator point of view.

Furthermore, to make this solution attractive to the end customer, it is important to provide a data rate and a price comparable to terrestrial solutions. Therefore, the need to design missions providing the highest capacity, expressed in Gbps, at the lowest cost, expressed in terms of M€/Gbps. More details of the cost advantages are presented in [7]

2.1 Baseline Reference Mission

The baseline reference mission selected in this study was a VHTS.

Such satellite missions address mainly the maritime and aerial connectivity markets as well as the broadband internet market for underserved regions.

To do this, they rely mostly on a star topology implementation with, on one side, several Gateways connected to the internet backbone through internet Points of Presence and, on the other side, the user terminals distributed over the service area provided by the narrow beams.

It is possible to define two links:

- The forward link providing connectivity from the Gateway to a user terminal.
- The return link providing connectivity from a user terminal to the Gateway.

Current HTS systems operate in either Ka or Ku-band, although this does not have to be the case. Although existing solutions could be envisaged to benefit from flight heritage from previous missions, other frequency bands for the feeder links could be exploited. The addition of other frequency bands could maximise allocated bandwidths, simplify frequency plans, and remove constraints on gateway locations. This implies that other spectrum will be required for the Gateways.

For the PhLEXSAT mission scenario, a 1-Tbps capacity has been targeted. This is achieved by a network of 13 Gateways making use of all the available RF spectrum in V- and W-Bands on both uplink and downlink:

GW Forward Uplink (Dual Polarisation):

V-Band: 42.5 – 43.5, 47.2 – 50.2 and 50.4 – 52.4 GHz

W-Band: 81 – 86 GHz

GW Return Downlink (Single Polarisation):

Q-Band: 37.5 – 42.5 GHz

W-Band: 71 – 76 GHz

On the User side, the service area is divided in 500 beams each one with 500 MHz of allocated bandwidth. All User beams are working in Ka-band single polarisation for both User Forward Downlink (17.3 – 20.2 GHz) and User Return Uplink (27.5 – 30 GHz).

3. PAYLOAD CONCEPT

3.1 Payload Architecture

Once the mission scenario has been defined, it is possible to start working on the mission architecture based on a PhLEXSAT solution. On the uplink side, all Gateway and User signals will go through filtering and amplification prior to being photonicallly sampled for down-conversion. Once the signals are digitized by the ADC, the input signal is channelized and routed towards the output Photonic DAC that will convert the signal back to RF and perform up-conversion. This is followed by a final filtering and amplification section prior transmitting the signal to either a Gateway or a User beam. The block diagram of the proposed architecture is shown in Figure 1.

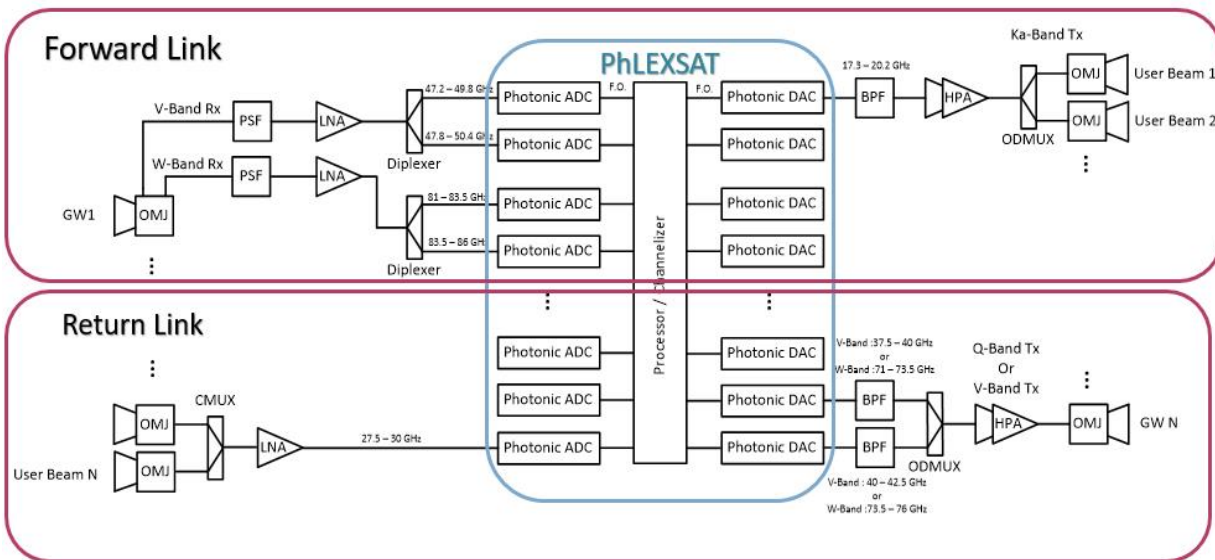

Figure 1 – VHTS payload architecture based on PhLEXSAT solution

3.2 Demonstrator Architecture

The PhLEXSAT demonstrator developed in this project consists of the following units:

- one Photonic Clock in charge of generating an LO reference at around 5.2 GHz of pulse repetition frequency
- one Photonic Clock distribution sending the reference photonic clock towards the Photonic ADC-MZI and Photonic DAC-MZI units
- one Photonic ADC-MZI capable of optical sampling of input RF signals up to the W-band (DC-86 GHz)
- one Photonic ADC-PD working in C-band (DC-6 GHz) in converting the photonic signal back to RF
- one ADC converting the RF signal into a digital bit stream,
- one Transparent Digital Processor (TDP) implementing a channelizer based on a Polyphase Filter Bank architecture as described in [8] allowing to generate channels of variable bandwidth, applying user defined gain and connecting any input port to any output port,
- one DAC converting the digital stream back to RF,
- one Photonic DAC-MZI performing optical sampling of RF signals from DAC,
- three Photonic DAC-PD each one working at a different band (Ka-, Q- and V-band) converting the photonic signal back to RF

The architecture of the PhLEXSAT photo-digital channelizer demonstrator is shown in Figure 2.

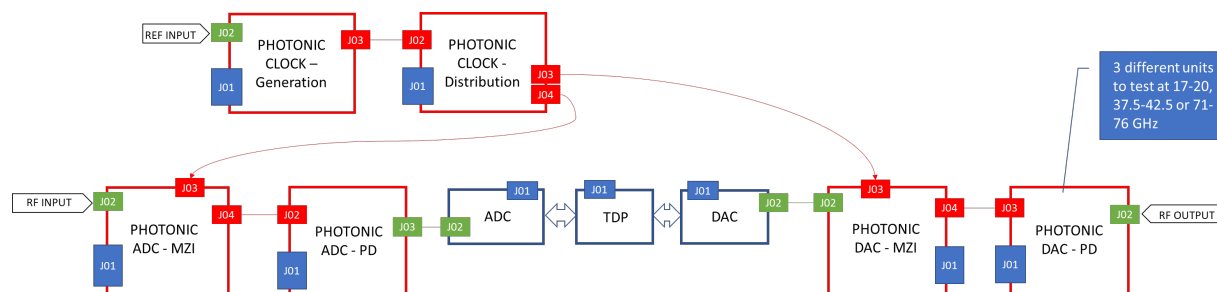

Figure 2. Architecture of the PhLEXSAT photo-digital channelizer demonstrator

The Photonic ADC-MZI and Photonic DAC-PD will be separate units to keep them in a real implementation close to the repeater input and output accesses to reduce RF losses, which can be quite significant as this payload operates at high frequency bands. On the other side, the Photonic ADC-PD and Photonic DAC-MZI will be kept close to the Transparent Digital Processor (TDP) as it is likely to be implemented in a real scenario as a single block to facilitate the data stream circulation among the different boards. The interconnection between the units is done by optical fibre allowing to fully exploit the fibre optics light mass, harness routing simplification and immunity to EMC.

The electronic ADC, DAC and FPGA implementing the TDP are implemented in individual PCBs separated from the Photonic ADC-PD unit and Photonic DAC-MZI unit, respectively. This solution offers more flexibility in testing and verification of different ADC/DAC components for upgrading of sampling frequency, considering the sampling frequency up to 10-12 GSps required from mission scenario and ADC/DAC chips currently available up to 6 GSps and under development up to 12 GSps.

4. DESIGN AND DEVELOPMENT OF THE PHLEXSAT COMPONENTS

Design of the Photonic Clock (Photonic Clock-Generation unit, Photonic Clock-Distribution unit), Photonic ADC (Photonic ADC-MZI unit, Photonic ADC-PD unit, Electronic ADC board), Photonic DAC (Photonic DAC-MZI unit, Photonic DAC-PD unit, Electronic DAC board) and TDP board is presented in this section.

4.1 Photonic Clock

The subsystem is composed of two photonic units for the PhLEXSAT demonstrator namely Photonic Clock-Generation and Photonic Clock-Distribution. The Photonic Clock-Generation unit is composed of a mode-locked laser (MLL), and a Phase-Locked Loop (PLL) integrated within a mechanical interface with one RF input for synchronization to an external reference oscillator and one optical output. The Photonic Clock-Distribution unit is composed of an optical amplifier and optical splitter integrated within a mechanical interface with one optical input and two optical outputs to drive the Photonic ADC and Photonic DAC for optical sampling. The Photonic Clock-Distribution unit will be simplified to demonstrate the PhLEXSAT concept. However, in a real payload, this unit would be composed by several cascaded connected stages, to cover the whole number of ADCs and DACs required in the satellite.

Photonic Clock Specification

The specifications of the Photonic Clock units are summarized in Table 1:

Table 1. Photonic Clock Specification

Parameters	Value	Unit
Centre wavelength	1550	nm
Pulse Repetition Frequency (PRF)	>5.2	GHz
External clock frequency (synchronization)	100	MHz
Pulse width	< 1	ps
Phase noise	-51-10log(f) 1Hz<f<1MHz -111 dBc/Hz f>1MHz	dBc/Hz
Level of spurious outputs	<50	dBc
DC power	+15/-15/+6	V
TM/TC	CAN bus	
Optical output interface	1550nm PM fibre with FC/APC connector	
Power & TM/TC connector	MicroD-15 (m)	
RF input connector	SMA (f)	

Photonic Clock Design

The block diagram of the Photonic Clock is shown in Figure 3.

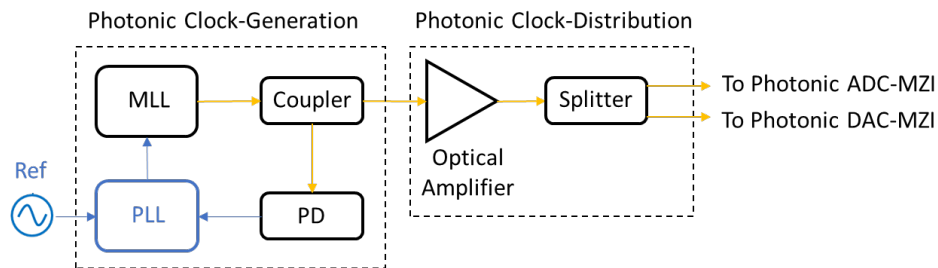

Figure 3. Block diagram of the Photonic Clock.

The main blocks of the Photonic Clock under development in PhLEXSAT are:

- MLL with a piezoelectric component
- Reference frequency PLL generator, which drives the piezo to stabilize the fundamental pulse repetition frequency of the MLL
- Optical Power Amplifier

4.2 Photonic ADC

The Photonic ADC is capable of down-converting and digitizing band-pass signals up to the W-band. It consists of two photonic units, MZI and PD interconnected by optical fibre, and one electronic ADC board:

- MZI unit: it consists of a mechanical interface with one RF input interface, one optical input for the Photonic Clock and one optical output connected to the PD unit. The unit integrates the Photonic ADC-MZI subsystem based on MZI PIC (DC-86 GHz) mounted on a PCB. The PCB includes the electronic circuitry for MZI bias control, which is implemented outside the Photonic ADC-MZI subsystem package via the DC bias ports.
- PD unit: it consists of a mechanical interface with one optical input connected to the MZI unit and one RF output (data signal for the electronic ADC). The unit integrates the Photonic ADC-PD subsystem based on HL-PD PIC + TIA (DC-6 GHz) mounted on a PCB. The PCB includes the electronic circuitry for PD and TIA bias.
- Electronic ADC board acting as quantizer: it consists of a COTS board with one clock input (sampling clock), one analogue data input, and high-speed lines for the digital signal outputs.

Photonic ADC Specifications

The specifications of the Photonic ADC units are summarized in Table 2:

Table 2. Photonic ADC Specification

Parameters	Value	Unit
RF frequency range	DC-86	GHz
Operational Input Bandwidth	>2.5	GHz
Sampling Rate	>5.2	Gsps
Input RF impedance	50	Ω
Effective number of bits (ENOB)	>7	
Spurious Free Dynamic Range (SFDR)	>50	dB
Distortion C/I3	>45	dBc
SNIR	>45	dB
Number of Optical inputs	1	
Number of RF inputs	1	
Number of digital outputs	8	

Photonic ADC Design

The block diagram of the Photonic ADC is shown in Figure 2. As a result of the photonic sampling, the spectrum of the RF input is repeated at multiples of the sampling frequency (pulse repetition frequency of the photonic clock) and the replica at DC-6 GHz will be used.

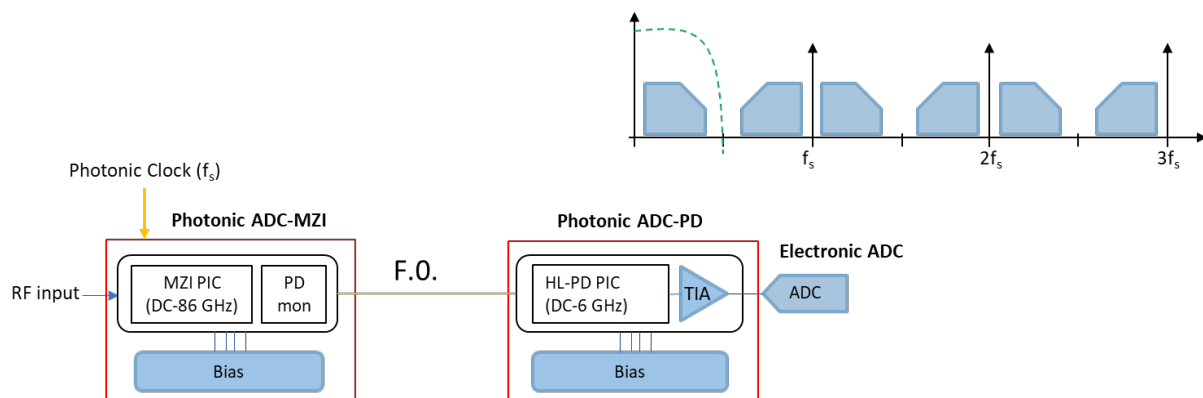

Figure 4. Block diagram of the Photonic ADC.

4.3 Photonic DAC

The Photonic DAC is capable of converting to analogue and up-converting signals up to the V-band. It consists of one electronic DAC board and 2 photonic units MZI and PD interconnected by optical fibre:

- MZI unit: It consists of a mechanical interface with one RF input interface (data from the electronic DAC), one optical input for the Photonic Clock and one optical output connected to the PD unit. The unit integrates the Photonic ADC-MZI subsystem based on Driver amplifier + MZI PIC (DC-6 GHz) mounted on a PCB. The PCB includes the electronic circuitry for Driver power supply and MZI bias control which is implemented outside the Photonic ADC-MZI subsystem package via the DC bias ports.
- PD unit: It consists of a mechanical interface with one optical input connected to the MZI unit and one RF output. Three different PD units will be fabricated integrating the Photonic ADC-PD subsystem based on HL PD PIC 17-20 GHz, 37.5-42.5 and 71-76 GHz, respectively. The Photonic ADC-PD subsystem is mounted on a PCB including the electronic circuitry for PD bias.
- Electronic DAC board: It consists of a COTS board with one analogue data output and high-speed lines for the digital signal inputs.

Photonic DAC Specifications

The specifications of the Photonic DAC units are summarized in Table 3:

Table 3. Photonic DAC Specification

Parameter	Value	Unit
RF frequency range	17.3 to 20.2 37.5 to 42.5 71 to 76	GHz
Operational Output Bandwidth	>2.5	GHz
Sampling Rate	>5.2	Gsps
Output RF impedance	50	Ω
Effective number of bits (ENOB)	>7	
Spurious Free Dynamic Range (SFDR)	>50	dB
Distortion C/I3	>45	dBc
SNIR	>45	dB
Number of Optical inputs	1	
Number of RF outputs	1	
Number of digital inputs	8	

Photonic DAC Design

The block diagram of the Photonic DAC is shown in Figure 5. As a result of the photonic sampling, the spectrum of the RF input is repeated at multiples of the sampling frequency (pulse repetition frequency of the photonic clock) and the replica at Ka/Q/V band will be used.

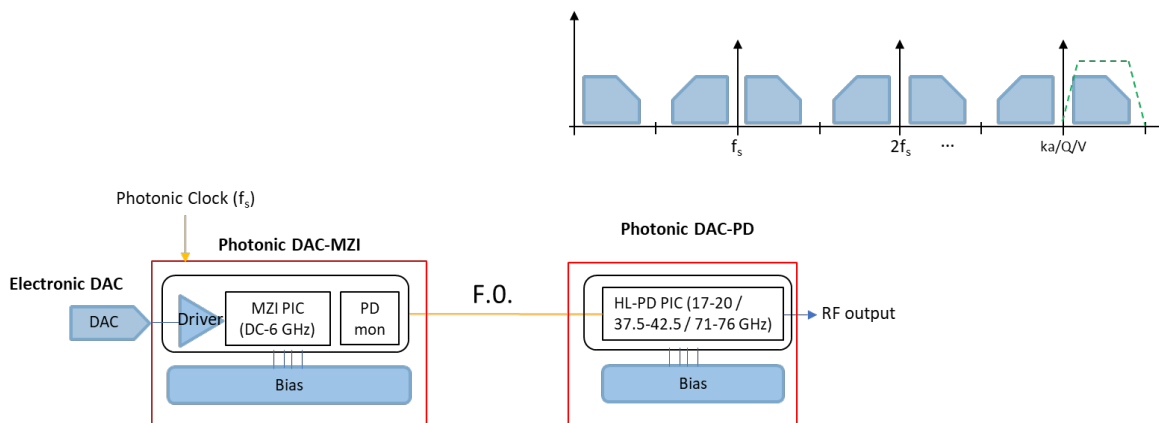

Figure 5. Block diagram of the photonic DAC

5. CONCLUSION AND FUTURE WORK

The consortium has presented the mission scenario for very high throughput satellites and analysed the suitability of the payload for various design drivers. A brief description of the demonstrator architecture has been identified.

Next step includes designing and breadboarding iteration on the optical clock, breadboarding of photonic sampler, under lab evaluation of high-speed data converters.

Final goal of this project is to build the photonic payload demonstrator with contribution by all the consortium members. To accomplish that the consortium is going through several intermediate phases of developing the components of the photonic payload like Mach-Zehnder Interferometer, High Linear photodetector, Channelizer, router, Multiplexer Photonic ADC, DAC and clock with required specification and performance.

6. ACKNOWLEDGEMENTS

The PhLEXSAT project is funded under the European Union's Horizon 2020 research and innovation programme under grant agreement No 101004253.

REFERENCES

- [1] Piqueras, M. A., *Recent advances of photonics processing in the satellite market*, Invited Paper, International Topical Meeting on Microwave Photonics (MWP), 2021, 15-17 November 2021, Virtual Conference.
- [2] Venet, N., Sotom, M., Gachon, H. and Foucal, V. et al. *High Throughput Optical Inter-Board Interconnects for Next Generation On-board Digital Transparent Processor* International Conference on Space Optics 2014
- [3] Karafolas, N. *Photonics in Telecom Satellite Payloads* European Space Agency lecture slides document
- [4] Pantoja, S., Piqueras, M. A., Villalba, P., Martínez, B., and Rico, E., *High performance photonic ADC for space applications*, International Conference on Space Optics—ICSO 2010, Rhodes Island, Greece, 4–8 October 2010

- [5] Anzalchi, J., Wong, J., Verges, T. and Navasquillo, O. *Towards Demonstration of Photonic Payload for Telecom Satellites*, International Conference on Space Optics—ICSO 2018, Chania, Greece, 9–12 October 2018
- [6] Anzalchi, J., Inigo, P. and Roy, B. *Application of Photonics in Next Generation Telecommunication Satellites Payloads*, International Conference on Space Optics, ICSO-2014, October 2014, Tenerife, Spain
- [7] Chatterjee, M., Palla, C., Fiamanya, E., Castells Cervello, A., Roux, A., Piqueras, M.A., Runge, P., Cameron, N., Zverina, J. *PhLEXSAT - A Novel Photo-Digital Communication Payload for Very High Throughput Satellites*, IAC-21-B2.4.5, IAC 2021, Dubai, October 2021
- [8] Harris, F., Dick, C., Rice, M. *Digital Receivers and Transmitters Using Polyphase Filter Banks for Wireless Communications*, IEEE Transactions on Microwave Theory and Techniques, Vol. 51, No. 4, April 2003