

First Four Centuries of Slovenian Vacuum Techniques

Stanislav Južnič

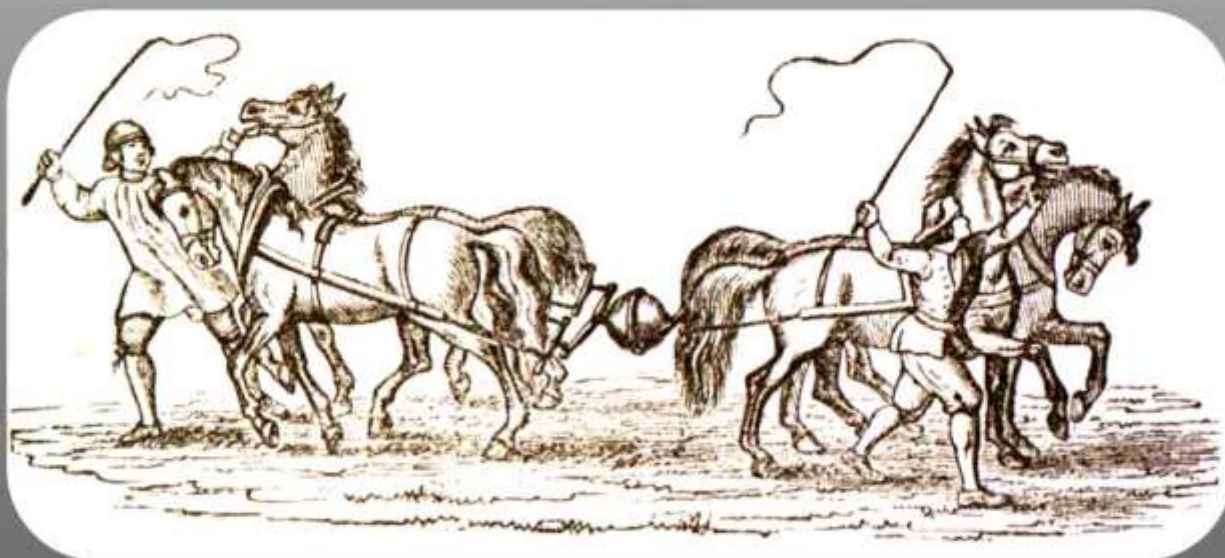

Slovenian Society for Vacuum Technique
2021

First Four Centuries of Slovenian Vacuum Techniques

Author: **prof. dr. Stanislav Južnič**

Translation: prof. dr. Stanislav Južnič (DZTPS accredited Translator no. 216-301/20)

Proofreader: prof. dr. Stanislav Južnič

Editor: dr. Peter Panjan

Layout: dr. Peter Panjan

Publisher: Slovenian Society for Vacuum Technique

For the publisher: prof. dr. Alenka Vesel

Acknowledgment: We thank Slovenian Research Agency (ARRS) for financial support of this edition

Kataložni zapis o publikaciji (CIP) pripravili v Narodni in univerzitetni knjižnici v Ljubljani
COBISS.SI-ID=44183043
ISBN 978-961-94431-1-8 (pdf)

Copyright © 2021 by Stanislav Južnič. All rights reserved. No part of this publication may be reproduced or distributed in any form or by any means, or stored in data base or retrieval system, without the prior written permission of the author.

Cover photo: The experiment of Guericke and prince Auersperg of Carniola with Magdeburg hemispheres conceived by the professor at the Zagreb Higher Real School Slovenian Ivan Tušek (* 1835; † 1877) two centuries after the first experiments in his translation of Schoedler's Physics in Ljubljana in 1869 on page 94, figure 111 (page 82 of original print in Braunschweig in 1865).

This book is dedicated to the teacher of us all, Jože Gasperič (1932-2019), who have played a decisive role in the education of Slovenian experts for vacuum science and technique

This treatise is published to celebrate the 350th anniversary of return of the first Slovenian experimental researcher of vacuum Janez Vajkard Auersperg (Turjaški) to Ljubljana-Žužemberk in 1669/70, and 60th anniversary of establishment of Society for Vacuum Technique of Slovenia (DVTS) and its journal Vakuumist)

Stanislav Južnič

First Four Centuries of Slovenian Vacuum Techniques

Slovenian Society for Vacuum Technique
Ljubljana, 2021

Index of Main Topics

I. Prelude: Philosophical Beginnings of (Seemingly Impossible) Vacuum

- 1 Foreword
- 2 Reflections on Emptiness among Slovenes Once and Today
- 3 No Experimental Tools for Vacuum

II. Fugue: Pumping & Measuring of Vacuum Related New Materials

- 4 Early Metrology: Barometers & Manometers
- 5 Pumps & Maintaining the Vacuums with Gettering
- 6 Books about Vacuums
- 7 First Major Industrial Uses of Vacuum and Overpressure Technologies: Steam Engines
- 8 Pioneering Vacuum Electronics: Low-Pressure Glow Discharge Tube
- 9 Plasma Waves or Corpuscles for New Aggregate State?
- 10 Advanced Metrology
- 11 New Thin Films Materials: Sputtering, Condensation, Evaporation, Blistering
- 12 New Materials with their Thin Films: Vacuum Metallurgy
- 13 Analyzing Surfaces: New Materials with their Thin Films

III. Intermezzos: Export of Vacuum Designs into Foreign Lands & Unexpected Uses

- 14 European Vacuums for Far Easterners
- 15 Pumping Vacuum for Full Enlightenment
- 16 Vacuum for Entertainments: Balloons
- 17 Ether in Vacuum
- 18 Industrial Uses of Vacuum Technologies: Modern Electronics
- 19 Household Domestic Uses of Vacuum Technologies: Food Processing & Vacuum Cleaners
- 20 Ether full of Plasma & Total Vacuum: When There's Nothing Left & Forth Aggregate State
- 21 Maintaining the Vacuums: Insulation

IV. Arias: Vacuum for Advanced Industries, Sciences & Entertainments

- 22 Major Industrial Uses of Vacuum Technologies: Thermos Flasks
- 23 Major Industrial Uses of Vacuum Technologies: Bulbs and Stefan's Radiations
- 23 Major Industrial Uses of Vacuum Technologies for Roentgen
- 24 Major Scientific Uses of Vacuum Technologies: Electrons
- 25 Major Industrial Uses of Vacuum Technologies: Electron microscope
- 26 Major Scientific Uses of Vacuum Technologies: Accelerators
- 27 Vacuum for Entertainments: Television
- 28 Major Industrial Uses of Vacuum Technologies: Ion Implantation for Transistors
- 29 Industrial Uses of Vacuum Technologies: Crookes's Vision Materialized in Ether full of Plasma
- 30 Industrial Uses of Vacuum Technologies: IJS & IEVT & Haldane
- 31 Industrial Uses of Vacuum Technologies: Luminescence

V. Finale: Organizing Vacuum Researchers & Backfired Philosophical Issues

32 Expert Societies for Expert Firms

33 Vacuum Questions Philosophers & Theologians

34 Summary: As an Epilogue

35 Keywords/Acknowledgements/ Literature and Sources/ Indexes

Detailed Index as Table of Contents

1	Foreword as Introduction.....	5	5.2.4	Conclusion.....	102
2	Reflections on Emptiness among Slovenes Once and Today.....	13	5.3	First Prince Auersperg and the Capuchin Valeriano Magni.....	102
3	No Experimental Tools for Vacuum.....	14	5.3.1	Introduction.....	102
3.1	Vacuum: Concept Development.....	14	5.3.2	Rheita, Auersperg and Schönborn.....	102
3.1.1	The Vacuum in Antiquity - Introduction.....	14	5.3.3	Vacuum Experiments of Capuchin Valeriano Magni.....	103
3.1.2	Aristotle.....	14	5.3.4	Marsenne Extends Knowledge of Vacuum.....	112
3.1.3	Ancient Researchers after Aristotle ..	15	5.3.5	Conclusion.....	112
3.2	Early Thinking about Empty among Slovenes.....	15	5.4	Academic Ancestors of the First Carniolan Vacuum Researcher, Janez Vajkard, Prince of Auersperg.....	112
3.2.1	Empress's Thin Films.....	15	5.4.1	Introduction.....	112
3.2.2	Copernicus on Vacuum.....	48	5.4.2	Training during Studies.....	113
3.2.3	Vacuum of Trubar's Days.....	54	5.4.3	Definition of the Time of Janez Vajkard Auersperg's School Days in Lower Schools.....	114
3.3	Conclusion.....	67	5.4.4	The First Carniolan Vacuumist's Brother and his Friend Librarian Schönleben ..	119
4	Early Metrology: Barometers & Manometers.....	69	5.4.5	Wilpenhoffer Helps his Religious Co-brother Kircher's Correspondence with Carniolan Pioneer of Research of Vacuum.....	121
4.1	Experiences with Vacuum in the Middle of the 17 th Century: the First Uses of Vacuum in Barometer.....	69	5.4.6	The Confessor of the First Carniolan Vacuumist.....	124
4.1.1	Galileo's Disciples.....	69	5.4.7	Conclusions.....	127
4.1.2	Pascal for the Frenchmen.....	72	5.5	The First Vacuum Pumps among Slovenes ..	128
4.2	Touching Vacuum for the First Time.....	75	5.5.1	Introduction.....	128
4.2.1	Introduction.....	75	5.5.2	Guericke's Inventions among Slovenes.....	128
4.2.2	Two Approaches to Vacuum Dedicated to the Late 17 th Century: Manuscripts in Oklahoma University.....	75	6	Books About Vacuums.....	146
4.2.3	Galileo's Relative in Carniola Propagating Early Vacuum Technology.....	81	6.1	Vacuum among Carniolans at End of the 17 th and in 18 th Centuries.....	146
5	Pumps & Maintaining the Vacuums with Getters.....	86	6.1.1	Vacuum Books in Ljubljana at the End of the 17 th century.....	146
5.1	Pumps in the Second Half of the 17 th Century.....	86	6.1.2	The Vacuum Related Instruction at the Jesuit College in Ljubljana (1706 -1773) ..	148
5.1.1	Guericke and the Research of Vacuum in the German Speaking Provinces....	86	6.2	Vacuum Related Books on Slovenian Soil ..	154
5.1.2	Auersperg, the First Carniolan Vacuum Enthusiast.....	87			
5.2	First Carniolan Vacuum Researcher: Books on the Vacuum of the First Ljubljana Vacuum Researcher.....	94			
5.2.1	Introduction.....	94			
5.2.2	Galileo and Kepler's Ideas in Auersperg's Networks.....	95			
5.2.3	Guericke's Vacuum Experiments at Auersperg's Ljubljana Library.....	99			

6.3	Books on the Vacuum once Owned in Cistercian Library in Stična of Lower Carniola.....	
	158
6.3.1	Introduction.....	158
6.3.2	Cistercian Vacuum.....	160
6.3.3	Stična Books	162
6.3.4	Conclusion	173
6.4	Capuchin and Franciscan Vacuum in the Middle of the 17 th Century	174
6.4.1	The First 800 Years of Franciscan Vacuum for Slovenes	174
6.4.2	Franciscans for Ljubljana Jesuits: North Italian Pace.....	183
6.4.3	Franciscan Library in Novo Mesto	184
6.4.4	Vacuum Devices of Bernard Vovk in Novo Mesto.....	188
6.5	Vacuum of Franciscans in Ljubljana	188
6.5.1	Introduction.....	188
6.5.2	Škerpin's Merits.....	188
6.5.3	Early Franciscans in Ljubljana Questioned the Vacuum	190
6.5.4	Ljubljana Franciscans in Favor of Vacuum	210
6.5.5	Users of the Franciscan Books about Vacuum in Ljubljana.....	248
6.5.6	Bavarian Vacuum for Ljubljana Franciscans: Bavarians Taught Vacuum Technology to Carniolan Literati	262
6.5.7	Conclusion	269
6.6	Valvasor about Vacuum and Thin-walled Sculptures	270
6.6.1	Introduction.....	270
6.6.2	Thin-wall Statues	271
6.6.3	Galileo's Circle in Valvasor's Networks	273
6.6.4	Boyle's Vacuum Pump for His RS Fellow Valvasor	274
6.6.5	Boyle's Antagonists	277
6.6.6	Conclusion	279
6.7	Vacuum of Baron Zois.....	280
6.7.1	Introduction.....	280
6.7.2	The End of Jesuit Dominance in the Ljubljana Vacuum Survey.....	280
6.7.3	Vacuum Technique of Illyrian Provinces at Central Schools in Ljubljana (1809-1813).....	281
6.7.4	The Jew Gunz - Ljubljana Brightest Scientific Star	284
6.7.5	Kersnik and Zois's Model of Vacuum Blast-furnace.....	288
6.7.6	Science Outside the Center of the Illyrian Provinces in Novo mesto, Gorizia, Trieste, Koper, Zadar.....	289
6.7.7	Capuchins and Franciscans in French Ljubljana and Gorizia.....	290
6.7.8	Zois's Vacuum Science in his Networks Captured by the Armed French Gentleman.....	290
6.7.9	Zois's Library.....	291
6.7.10	Swedenborg's Improvements for the Baron Zois	302
6.7.11	Conclusion.....	303
6.8	Erberg's Vacuum-related Books	303
6.9	Books on Vacuum Experiments in Slovenia before Cathode Ray Tubes	304
6.10	Three Hundred Years since Birth of Founder of First Modern Physics-chemistry Laboratory in Area of Slovenia	305
6.10.1	Graz and Viennese Applied Mathemaatics.....	306
6.10.2	Graz for Ph.D.	306
6.10.3	Judenburg Probation.....	310
6.10.4	Ljubljana Lab: Bernardin Ferdinand Erberg Reforms the Physics Lecturing in Ljubljana.....	311
7	First Major Industrial Uses of Vacuum and Overpressure Technologies: Steam Engines	327
7.1	Steam Engines - Introduction.....	327
7.2	Vacuum Technology in a Steam Engine	327
7.3	Steam Engines in Carniola.....	328
7.4	The First Steam Engines Discussed in Print among Slovenes.....	329
8	Pioneering Vacuum Electronics: Low-Pressure Glow Discharge Tube	332
8.1	The Rapid Progress of Vacuum Technology in the Second Half of the 19 th Century	332
8.1.1	Stagnation in the Development of Vacuum Technology by the Middle of the 19 th Century	332
8.1.2	Use of Vacuum in Cathode Ray Tube	333
8.2	Slovenian Vacuum Researchers after the Invention of the Cathode Ray Tube.....	337
8.2.1	The Equipment of Slovenian High Schools during the Great Progress of Vacuum Technology	337
8.2.2	Šubic's Research on the Transmission of Electricity in Gases at the University of Graz	342
8.2.3	Šantel's Vacuum Pump at the Grammar School in Gorizia.....	343

8.3	Breakthrough of Vacuum Technology into Industry at the End of the 19 th and Early 20 th Centuries	347	12.1.9	Separation Metallurgy (Reduction)..	390
8.4	Conclusion	349	12.2	Thin Films Technologies	391
9	Plasma Waves or Corpuscles for New Aggregate State?	351	12.2.1	Beginnings.....	391
9.1	Beginnings of the Research of "Cathode Rays" at the End of the 19 th Century.....	351	12.2.2	Thin Films on Glass	391
9.2	Supporters of the Wave Model	351	12.2.3	Glassware Development.....	392
9.3	Corpuscular Model and Crookes	351	12.2.4	Antireflection Coatings	392
9.4	Waves and Particles at the Same Time.....	352	12.2.5	Metal Mirrors	393
10	Advanced Metrology	354	12.2.6	Hard Coatings.....	394
10.1	Development of Manometers	354	12.2.7	Thin Films in the Cathode Ray Tube	395
10.2	McLeod's Compression Gauge	354	12.2.8	Slovenian Thin Films	395
10.3	Viscosity Pressure Gauges.....	355	13	Analyzing Surfaces: New Materials with their Thin Films	399
10.4	Application of a Radiometric Measurement of Pressure	356	13.1	The First Century of Auger Electron Spectroscopy for Measuring of the Composition of Thin Films - Introduction	399
10.5	Mechanical Pressure Gauge (Manometer).... ..	360	13.2	Discovery	399
10.6	Hot Cathode Ionization Meters.....	360	13.3	Application to Industry	405
10.7	Cold Cathode Ionization Meters	362	13.4	Auger Electrons in Slovenia	406
11	New Thin Films Materials: Sputtering, Condensation, Evaporation, Blistering	364	13.5	Conclusion	407
11.1	Experiments with the Sputtering of Metals and Thin Films in the 19 th Century	364	14	European Vacuums for Far Easterners.....	408
11.1.1	The Discovery of the Sputtering of Metals in England.....	364	14.1	Hallerstein Exports Carniolan Science ..	408
11.1.2	Measurements in Germany and Austria	366	14.2	Vacuum Pump in Hallerstein's Beijing: Voids Allowed in the Forbidden City	408
11.2	Theories of Blistering of Metals	377	14.3	Hallerstein's Vacuum Related Books and Tools	413
11.2.1	Stark's Theory of the Blistering of Metals	377	14.3.1	Introduction: Books also Like to Travel, Do they Not?	413
11.2.2	Modern Theory	377	14.3.2	Hallerstein's Ljubljana Scientific Background.....	414
11.2.3	Conclusion	378	14.3.3	Beijing Experiments with Electricity	415
12	New Materials with their Thin Films: Vacuum Metallurgy.....	380	14.3.4	Hallerstein's Vacuum-related Books	419
12.1	Vacuum Metallurgy	380	14.4	Habsburg-Slovenian Vacuum for the Far East	427
12.1.1	Introduction.....	380	14.5	Early Japanese Vacuum Techniques.....	427
12.1.2	Arc Melting of Metals in Vacuum	381	14.5.1	Introduction	427
12.1.3	Melting of Metals in a Vacuum ..	381	14.5.2	The Dutch Science Travels to the Habsburg Monarchy (1713-1795) and to Japan (1720-1853)	427
12.1.4	Vacuum Induction Melting of Metals	383	14.5.3	Rangaku伊學), Erekiteru (エレキ, エレキテル), and Vacuum Pumps in Japan	431
12.1.5	Metal Melting with an Electron Beam in a Vacuum	384	14.5.4	Erekiteru	434
12.1.6	Degassing of Metals in a Vacuum	385	14.5.5	Conclusion.....	441
12.1.7	The Theory of Absorption and Degassing of Metals	385	15	Pumping Vacuum for Full Enlightenment	443
12.1.8	Degassing of (Liquid) Steel in a Vacuum	387	15.1	Vacuum Pumps as Standard Experimental Tools for Enlightenment.....	443

15.2 Enlightenment Vacuum Pumps among Slovenes	443	15.8.2 Evaporation in Vacuum in 1788	493
15.3 Bošković's Vacuum	444	15.8.3 The Expansion of Gases in a Vacuum	499
15.3.1 Introduction.....	444	15.8.4 Vacuum Measuring Instruments	500
15.3.2 Bošković's Water-Filled Telescope ..	445	15.8.5 Conclusion.....	503
15.3.3 Dubrovnik Natives on Lana Terzi's Vacuum Balloons	446	15.9 Gruber on the Spread of Gases into a Vacuum.....	503
15.3.4 Conclusion	448	15.9.1 Introduction	503
15.4 Ljubljana Native's Vacuum Books in Brussels (On the 300 th Anniversary of the Birth of Janez Karl Philip Kobencel)	449	15.9.2 T. Gruber on Thermal Phenomena in Diluted Air (1788, 1791)	504
15.4.1 Introduction.....	449	15.9.3 Specific Heat of the Caloric Theory.	509
15.4.2 Kobencel and Coronini for Bošković .	449	15.9.4 Joule-Thomson Cooling.....	515
15.4.3 Technique of Guido Kobencel, Younger Brother of Brussels Minister Janez Karl Filip Kobencel.....	450	15.9.5 Conclusion.....	516
15.4.4 Kobencel Supports Sciences in Brussels	451	15.10 Vacuum Becomes Part of the Electrical Industry.....	516
15.4.5 Brussels Books.....	452	15.10.1 Vacuum Devices of the First Professor of Physics in Slovenia, Who was not a Member of the Monastic Order (on the 250 th Birthday of Neumann).....	516
15.5 Gian Rinaldo Carli - First Professor of Technical Sciences from the Area of Present-day Slovenia.....	460	15.10.2 Neumann's Ljubljana Predecessors .	517
15.5.1 Introduction.....	460	15.10.3 Ljubljana Physics	519
15.5.2 Vacuum Techniques by Paduan Professor Carli.....	461	15.10.4 Graz and Vienna.....	519
15.5.3 Carli and Tartini	462	15.10.5 Textbook about Physics	520
15.5.4 Electricity	462	15.10.6 Conclusion.....	523
15.5.5 Upgrading the Education of Chemistry and Related Sciences in Lombardy	466	16 Vacuum for Entertainments - Balloons.....	525
15.5.6 Carli and Bošković.....	467	16.1 Vacuum Balloons.....	525
15.5.7 Carli's Books	468	16.1.1 Exploitations in the Sixteenth Century	525
15.5.8 Conclusion	471	16.1.2 Vega and the First Balloons	527
15.6 Ljubljana Teaching Aids Upon the Suppression of the Jesuit Society	471	16.2 A Slovenian with a Vacuum Balloon and his Last Will (on the 250 th Anniversary of the Birth of the Pioneer of Slovenian Flights Gregor Kraškovič of Bloke)	529
15.6.1 Erberg.....	472	16.2.1 Introduction	529
15.6.2 Gruber's School Tools in 1768...	473	16.2.2 Training of a Future Balloonist..	529
15.6.3 Ambschell's Devices in 1779 and 1785	476	16.2.3 Kraškovič on the History of Aviation	530
15.7 Volta's Relative and His Idrija Pharmacy: Idrija Mercury for Barometers and Thermometers (on the 275 th Anniversary of Volta's Birth)	482	16.2.4 Kraškovič's Balloons and Parachutes (Paragliders)	537
15.7.1 Introduction.....	482	16.2.5 Prechtel on Kraškovič	539
15.7.2 Abondio Inzaghi and Torricelli...	482	16.2.6 Inner Carniolan Kraškovič in Dubrovnik.....	542
15.7.3 Idrija Pharmacist	487	16.2.7 Testament	544
15.7.4 Conclusions.....	489	16.2.8 Books on Vacuum Techniques...	545
15.8 Vacuum Gauges by Tobias Gruber.....	489	16.2.9 Conclusion.....	555
15.8.1 Introduction.....	489	17 Ether in Vacuum	559

17.1 Ether as a Vacuum: Cauchy's Gorizia Vacuum Theory - Introduction.....	559	18.5.7 Northern Light and Fluorescence.....	627
17.2 Cauchy's Gorizia Vacuum.....	562	18.5.8 Tesla in Graz	631
17.3 Cauchy's Thin Layer Optics of Stefan's Teacher Robida	563	18.5.9 Tesla in Maribor.....	639
17.4 The Vacuum in Cauchy's Optics	564	18.5.10 Maribor Telephones	645
17.5 Conclusion	568	18.5.11 Lower Styrian Members of Naturalists Society.....	646
18 Industrial Uses of Vacuum Technologies: Modern Electronics.....	570	18.5.12 Maribor Opportunities.....	651
18.1 Cathode Ray Tubes's Electronics among Slovenes	570	18.5.13 Puch's Bicycles	655
18.2 Vacuum Pumps among Slovenes after the Spring of Nations of 1848.....	576	18.5.14 Humiliating Arrest and Exile	655
18.2.1 Geissler, Crookes, X-ray and Braun's Cathode Ray Tubes for Slovenians	576	18.5.15 Gospić Again.....	661
18.2.2 The First Photographs of the Supersonic Missiles of the Son of the Landowner in Gorjanci Region for the Recording of Modern Plasma Turbulences in the Magnetron	577	18.5.16 Tesla in Prague.....	662
18.3 Hočevar's Vacuum Techniques.....	586	18.5.17 Tesla Celebrated in his Native Central Europe.....	664
18.3.1 Introduction.....	586	18.5.18 Tesla and Bošković	677
18.3.2 Hočevar in Ljubljana.....	586	18.5.19 Tesla and Pupin.....	677
18.3.3 Study in Vienna.....	590	18.5.20 Importance of Maribor Affairs for Tesla's Success.....	679
18.3.4 In Tyrol and Moravia.....	590	18.5.21 Nikola Tesla for Healthy Eating and Free Energy	679
18.3.5 Hočevar on Holtz's Influence Machine and Geissler's Vacuum Cathode Ray Tube	592	18.6 Vacuum of the President's Uncle.....	682
18.3.6 Hočevar about Wheatstone Bridge	596	19 Household Domestic Uses of Vacuum Technologies: Food Processing & Vacuum Cleaners	689
18.3.7 Conclusion	597	19.1 Vacuum Technology for Cooking and for the Preparations of Food.....	689
18.4 Tesla's Vacuum Researches	597	19.1.1 Introduction	689
18.4.1 Introduction.....	597	19.1.2 Guericke's Grapes	689
18.4.2 Tesla's Electrons and X-rays in Crookes's Vacuum	599	19.1.3 Boyle's Vacuum Pump and Wine.....	692
18.4.3 High Voltage Discharges of Tesla's Slovenian Jesuitical Precursors	601	19.1.4 Thermos.....	692
18.4.4 Tesla's Contemporaries Explore Arc Discharges in Slovenia.....	604	19.1.5 Packing.....	693
18.5 Tesla's Early Contacts with Vacuum Techniques	606	19.1.6 Lyophilisation (Freeze-drying) ..	694
18.5.1 Introduction.....	606	19.1.7 Cooking in a Vacuum.....	694
18.5.2 Tesla Teacher Sekulić and his Colleagues in Hungary.....	606	19.1.8 Futures of Cooking Sous-vide....	696
18.5.3 Sekulić and other Tesla's Teachers in Rakovac.....	612	19.2 Vacuum Cleaners	696
18.5.4 Tesla's Rakovac Classmates	619	20 Ether Full of Plasma: Total Vacuum: When there is Nothing Left & Forth Aggregate State	698
18.5.5 Tesla's Theory of Capillarity.....	621	20.1 Radiometer and Pursues for the Total Vacuums	698
18.5.6 Ether.....	625	20.2 Introduction: a Complete Vacuum.....	698
		20.2.1 Crookes's Discovery	700
		20.2.2 Crookes's Antagonists	702
		20.3 Maxwell and Reynolds' Theory of Radiometer	705
		20.4 From Radiometer to Cathode Ray Tube Electronics - "Electric" Radiometer	706
		20.5 Radiometer, Pressure of Light and Stefan's Law	708
		20.6 Radiometers in Slovenia	708
		20.6.1 Šantel's Experiments in Gorizia .	708

20.6.2	Radiometers in Cabinets for Physics in Slovenian Areas	709	22.2.4	Provincial Genius in Metropolis	766
20.7	Conclusion	709	22.2.5	Koller Enabled for Stefan's Academic Success	766
21	Maintaining the Vacuums: Insulations	710	22.2.6	Stefan's Collaborator Grailich against Robida and Mitteis' Electromagnetism	768
21.1	Thermos Flask: the Discovery and Development of Vacuum Insulation	710	22.2.7	Stefan Exploration of Kinetic Theory and Atoms	774
21.1.1	Exploration of Heat Transfer Through a Vacuum in England of the 19 th Century	710	22.2.8	The Radiation Law of Stefan	778
21.1.2	Heat Transfer Through Gases in Europe of 19 th Century: Stefan's Diathermometer.....	710	22.2.9	Stefan's Law among his Contemporaries.....	780
21.2	Dewar's Invention of Thermos Flask.....	711	23	Major Industrial Uses of Vacuum Technologies for Roentgen.....	783
21.3	Dewar in the Liquefaction Competition	712	23.1	Roentgen Rays for Electronic	783
21.4	Heat Transfer through Vacuum Insulation at Liquid Air Temperatures.....	714	23.2	Röntgen's Research on the Detection of Rays	783
21.5	Disputes about the Priority in the Discovery of Thermos	714	23.3	Discovery	783
21.6	Thermos Flask in Germany and the USA until the Middle of 20 th Century.....	715	23.4	Disputes on the Nature of X-Rays	784
21.7	Contemporary Followers of Dewar's Work.. ..	716	23.5	Experimental Determination of the Nature of X-Rays.....	785
22	Maintaining the Vacuums: Bulbs and Stefan's Radiations	717	23.6	Notes on Röntgen's Discovery in Habsburg Areas and in Slovenian Countries	786
22.1	The First Light Bulbs.....	717	23.6.1	On Röntgen's Invention in the German Language of Triestino Mosetig (Mozetič)	786
22.1.1	Edison's Bulbs.....	718	23.6.2	Slovenian Language Reports on X-rays	788
22.1.2	Vacuum Bulbs.....	720	23.6.3	Sirk's X-Ray Experiments in Ljubljana.....	789
22.1.3	Parallel Discoveries during the Edison's Research of the Bulb: Lamp Survey . ..	722	23.6.4	Conclusion.....	790
22.1.4	Carbon Filament Bulbs	723	24	Major Scientific Uses of Vacuum Technologies: Electrons.....	791
22.1.5	Tungsten Lamps.....	726	24.1	Thomson's Research of Negative and Positive Rays	791
22.1.6	Bulb in England, France, and Italy	728	24.1.1	"Cathode rays"	791
22.1.7	The Bulb in Germany and the Netherlands.....	729	24.1.2	Thomson's Study of "Positive" Rays (1906-1914)	803
22.1.8	Bulb in Habsburgian Monarchy.....	731	24.1.3	Search for the Atomic Composition.	803
22.1.9	Electric Bulb in Slovenia	734	24.1.4	Measurement of e/m Ratios of "Positive Rays"	804
22.1.10	The Bulbs in the Works of Stefan's Contemporaries and Students.....	736	24.2	Spread of Thomson's Ideas	806
22.1.11	The Arrival & Future of the Light: Lifestyle of the Bulb.....	738	24.2.1	Nobel Laureates among Thomson Co-workers and Rutherford.....	806
22.2	Stefan's Kinship.....	738	24.2.2	Echoes of Thomson's Research in Slovenia	806
22.2.1	Introduction.....	740	25	Major Industrial Uses of Vacuum Technologies - Electron Microscope	808
22.2.2	Genial Stefan as the Illegitimate Kid	741	25.1	Electron Microscopy	808
22.2.3	Marry or not to Marry, That is the Question on the Eve of Spring of Nations Revolutions in 1848	749	25.2	Optical Microscope	808

25.2.1	Early Users.....	808	27.6.9	Electronic Television in USA	841
25.2.2	Jena: Optical Microscope Capability	808	27.6.10	Color TV	844
25.3	Experiments with the Emission of Electrons in the Electromagnetic Field	808	27.6.11	Television in Slovenia.....	846
25.4	The Beginnings of an Electron Microscope	809	27.6.12	Codelli's Television.....	846
25.4.1	Abbe's Successors in Jena Accomplish his Vision	809	27.6.13	Codelli's Cathode Ray Tubes.....	851
25.4.2	Electron Microscope in Berlin	810	27.6.14	Problems with Politicians.....	856
25.5	"Parallel (Independent)" Discoveries in the Development of an Electron Microscope.....	811	27.6.15	Other Codelli's Inventions	857
25.6	The United States and England: the Refraction and Interference of Electrons	812	27.6.16	Slovenian Television before and After World War II.....	860
25.6.1	European Mainland Love Waves Spread Overseas	812	28	Major Industrial Uses of Vacuum Technologies	
25.6.2	England: Electron Microscope and Holography.....	812	-	Ion Implantation.....	861
25.7	Engineer Strojnik with the First Ljubljana Electronic Microscope	813	28.1	Rutherford's Discovery of Ion Implantation for Transistor	861
26	Major Scientific Uses of Vacuum Technologies		28.1.1	Introduction	861
-	Accelerators	816	28.1.2	Rutherford's Era	861
26.1	Accelerators: from Ideas to First Performances.....	816	28.1.3	Electrified Particles in Solid Matter: "Cathode Rays" of Helmholtz Pupils	862
26.2	Pre-history.....	816	28.1.4	Montreal and Paris: Ion Implantation Follows Absorption of α -rays (1905-1906)	862
26.3	Who Will Break the First Nucleus?.....	816	28.1.5	Rutherford in Manchester: Planter and Identification of α -rays with He ⁺⁺ (1908- 1909)	869
26.4	The English Won the Match.....	818	28.1.6	Rutherford's "Center Charge" of Atoms and Scattering of α -rays on Metals (1909-1914)	870
26.5	Accelerators Turn into "Big Science".....	819	28.1.7	Bohr in Manchester and Copenhagen: the Theory of Ion Implantation	873
26.6	Van de Graaff Generator	819	28.1.8	Rutherford's Research Affects the Networks of Slovenians.....	875
26.6.1	Early Ideas	819	28.1.9	Conclusion.....	876
26.6.2	The Ljubljana Van de Graaff	819	28.2	Discovery and Development of Transistor	877
26.7	Electron Accelerators.....	821	28.2.1	Introduction	877
27	Vacuum for Entertainments - Television.....	822	28.2.2	The Discovery of Silicon and Germanium	877
27.1	Cathode Ray Tubes and other Vacuum Elements for Television	822	28.2.3	Early Semiconductor Research ..	877
27.2	Naming of Television	822	28.2.4	Stefan-Braun's Discovery of a Potential Barrier in a Crystal Diodes (Detectors)	878
27.3	Sensors and Photocells	822	28.2.5	Semiconductor Research before World War II	880
27.4	The Amplifiers and Triode	824	28.2.6	Junction (Point Contact) Transistors	882
27.5	Scanners.....	828	28.2.7	FET Transistors	887
27.6	Cathode Ray Tubes's Electronics.....	828	28.2.8	Priority Problem	890
27.6.1	Braun.....	828	28.2.9	"Silicon Valley" and Research of Scientists in Industrial Laboratories	890
27.6.2	Zenneck.....	831	28.2.10	Application of Ion Implantation in the Semiconductor Industry.....	891
27.6.3	Other German Researchers: Wehnelt and Rogowski.....	832			
27.6.4	The "Mechanical" Television Development Period.....	833			
27.6.5	Television among Russians.....	833			
27.6.6	Television in the UK.....	834			
27.6.7	Television in Germany.....	837			
27.6.8	Mechanical Television in the US.....	840			

28.2.11 Transistor and the Beginnings of the Use of Ion Implantation in Semiconductors.....	892	Technique at the Time of Peterlin and Supek .	947
28.2.12 Integrated Circuits.....	893		
28.2.13 Ion Implantation at Higher Temperatures.....	897	30.2 Vacuum for Modern Slovenes	988
28.2.14 Ion Implantation as a Mature Form of Technology	899	30.2.1 Vacuum at the Time of Director Osredkar and Vacuum Techniques in the Nuclear Magnetic Resonance of Robert Blinc (*1933; †2011)	988
28.2.15 Conclusion	900	30.2.2 Honorable Professor Janez Strnad ...	999
28.3 Spread of Transistors to Europe	901	30.2.3 The Valley of the Upper Kolpa for Slovenian Vacuum Researchers Once and Today	1002
28.4 Development of Transistors in Slovenian Country.....	902	30.2.4 Duncan Haldane's Eight Part of Slovenian Nobel Prize	1002
28.5 Future of Transistors.....	903	30.2.5 Merits of Modern Slovenian Experts Connected with DVTS, IEVT, IMT and IJS ...	1008
29 Industrial Uses of Vacuum Technologies: Crooke's Vision Materialized in Ether Full of Plasma.....	904	30.2.6 The First Slovenian Female Vacuum Researchers.....	1014
29.1 Early History of Research of Plasma.....	904	30.2.7 Nanotubes.....	1026
29.1.1 Introduction.....	904	31 Industrial Uses of Vacuum Technologies - Luminescence.....	1039
29.1.2 A Weak Plasma in a Flame	904	31.1 History of Research of Luminescent Materials	1039
29.1.3 The Fourth Physical State	906	31.2 Research of Luminescence before the Discovery of Ultraviolet Lights.....	1039
29.2 Modern Plasma	907	31.2.1 First European Description of Fluorescence	1039
29.2.1 What Shines in the Sun?	907	31.2.2 The First European Artificial Luminophore: "Bologna Stone"	1040
29.2.2 Langmuir's Study of Fluctuations in a Plasma	910	31.2.3 Chemical Element Detection: Phosphorus	1042
29.2.3 Naming of Plasma.....	911	31.2.4 Investigation of Luminescence after the Discovery of Phosphorus.....	1044
29.2.4 "Pinch"- Effect	915	31.2.5 Echoes of Luminescence Exploration in Ljubljana.....	1046
29.2.5 The Kinetics of Plasma	917	31.3 Research of Luminescence in Germany after the Discovery of Ultraviolet Light	1051
29.2.6 Magnetohydrodynamics.....	917	31.4 Exploration of Solutions of Fluorescent Materials in England: the Stokes Law.....	1053
29.2.7 Continuing Langmuir's Research Into Plasma Fluctuations	919	31.4.1 Discussions on the Validity of Stokes' Law	1055
29.2.8 Nuclear Fusion	921	31.4.2 The Modern Theory of Stokes's Law	1057
29.2.9 Magnetic Traps and Stellarators	922	31.5 Exploration of the Phosphorescence of Solid Matter in France - E. Becquerel's Phosphoroscope.....	1059
29.2.10 TOKAMAK	925	31.6 Cathodoluminescence	1060
29.2.11 Laser Method	928	31.6.1 Discovery	1060
29.2.12 Uninterrupted Plasma Heating: Continuous Laser Method	928	31.6.2 Radioluminescence	1062
29.2.13 Future Research of Plasma and of Plasma Technologies.....	929		
29.2.14 Conclusion	930		
29.3 Slovenian Plasma: Sirk's Plasma and the Beginning of Physics at the University of Ljubljana	931		
30 Industrial Uses of Vacuum Technologies: IJS &IEVT&Haldane.....	938		
30.1 Peterlin's Contribution to the Development of Vacuum Techniques	938		
30.1.1 Introduction.....	938		
30.1.2 Samec's Spectral Analysis	938		
30.1.3 Samec Junior in Chemistry	945		
30.1.4 Peterlin's Experiments and Lectures on Vacuum Techniques: Slovenian Vacuum			

31.6.3	Cathodoluminescence in Braun's Cathode Ray Tube and Television Displays	1063	35	Keywords	1123
31.6.4	A Description of the First Luminophores Used for Television Displays.....	1064	36	Acknowledgements.....	1124
31.7	Bioluminescence and Chemoluminescence..	1065	37	Literature and Sources	1125
31.8	Research of Luminescence in the Habsburgian Monarchy and in Slovenian Areas....	1066	37.1	Unpublished Archival Sources with their Abbreviations and Cities	1125
31.9	Luminescent Lighting (Electro (Photo) Luminescence)	1068	37.2	WEB.....	1136
31.10	Conclusion	1072	37.3	Printed Sources	1139
32	Expert Societies for Expert Firms – and Vice Versa	1073	37.4	Index of Main Patents Noted	1295
32.1	Early European Vacuum Technology Companies.....	1073	37.5	Journals & Periodicals	1315
32.1.1	Introduction.....	1073	37.6	Index of Major Important Companies, Businesses, Institutions, Journals , Abbreviations and Lesser-Known Terms.....	1323
32.1.2	Heraeus	1073	37.7	Index of Noted Important Persons Mentioned (their deaths are designated by † even for people with no Christian background).....	1325
32.1.3	Leybold	1075	37.8	Index of Frequently Mentioned Places	1439
32.2	Vacuum Researchers in "Big Science" of the Second Half of 20 th Century.....	1076			
33	Vacuum Questions Philosophers & Theologians	1079			
33.1	Vacuum Philosophy.....	1079			
33.2	Slovenian Philosophical Minded Physics about Vacuum	1079			
33.2.1	Sašo Dolenc as Physicist-Philosopher.....	1079			
33.2.2	Structure of the Empty and Detela's Polyphase Cradles	1080			
33.3	Development of Vacuum Technology Under the Toynbee-Kuhn-Južnič Scheme	1082			
33.3.1	Introduction.....	1082			
33.3.2	Cathode Ray Tubes as Historical Case Study.....	1087			
33.3.3	Vacuum Experiments as a Motor for the Development of Physics and Chemistry in the Era of Crises	1090			
33.3.4	Contemporary Orientations in Slovenian Vacuum Tehnique	1092			
33.3.5	Conclusions.....	1097			
33.4	Vacuum as a Limit.....	1097			
33.4.1	Introduction.....	1097			
33.4.2	Limits Outside Physics	1100			
33.4.3	European Limits.....	1101			
33.4.4	Projection of the Vacuum of the Future	1105			
33.4.5	General Conclusion.....	1107			
34	Summary: as an Epilogue	1112			

Reviewer's Opinion

In the book *Vacuum and Vacuum Techniques History*, dr. Stanislav Južnič presents insights into the history of the vacuum research and history of the developments of the vacuum techniques he gained while studying archives both at home and abroad. The book is extensive, comprehensive, and it is intended for readers with a technical background who are also interested in the history of science. The contents of the book have mostly been published in the period 1993-2000 in *Vakuunist*, the bulletin of the Society for Vacuum Technology of Slovenia, and in three books written by dr. Južnič entitled *History of Vacuum Research and Vacuum Techniques*, Parts 1, 2 and 3, also published by the Society for Vacuum Technique Slovenia in 2004, 2010 and 2017. Some contributions were also published in some other publications.

Since vacuum techniques have been integrated into practically every field of the natural sciences until the 20th century, this work describes the whole history of physics, chemistry and related sciences. In his extensive work the author gives a historical overview of the world achievements in the field of vacuum sciences. He also provides a broad overview of the achievements of all those scholars who have worked in the region of present-day Slovenia in the last four centuries. Južnič's conclusion is that these scholars did not lag far behind their neighbors and that they even exceeded them in many ways. Many of these scholars are described and documented in detail in this book, like who their teachers were, their classmates, from which textbooks they were learning, and what teaching aids they were using. Of course, we can find out what kind of books have been published in the field of vacuum techniques as well as in other areas. Dr. Južnič also describes who their friends, supporters and opponents were. Also interesting is the fact that, at that time, these scholars worked very intensively with their colleagues in the European area as well as beyond. This is especially true of the close collaboration of the first Prince Janez Vajkard Turjaški (Auersperg) born in Žužemberk with the inventor of the vacuum pump, Otto Guericke. Special attention in this book is given to an overview of the books related to vacuum, which were accessible and present in the Slovenia

region. They were mainly available in the libraries of monasteries and some of them in private libraries. In this work is described an important role of Jesuits primarily engaged in science on the Slovenian region in the period from the 16th to the 19th centuries. The natural sciences were only part of their interest. However, the author of the book deals with their work in its entirety, so we find many interesting things in other fields of science where Jesuits were active. The author also described the importance of Slovenian Jesuits in the spread of European science to China and Japan, especially the significance of Augustine Hallerstein. The book also contains interesting descriptions of vacuum in period of Baron Zois, technology used by Janez Vajkard Valvasor, role of the Idrija mercury for vacuum barometers, measuring devices made by Tobias Gruber, brother of the better known Gabriel Gruber, builder of the Ljubljana Canal and General of the Jesuit Order and many other interesting matters. This book also contains numerous archival papers on Johann Philipp Neumann, the first professor of physics at the Faculty of Philosophy in Ljubljana and a pioneer of vacuum techniques in our space. Also interesting are the archival documents on the first Slovenian airplane and balloonist Gregor Kraškovič. His pioneering achievements in aviation, as well as in the field of vacuum engineering, can be our pride today. The vacuum related research performed by Jožef Stefan is also described and discussed in the book as well as the achievements of Baron Codelli in the field of the vacuum elements for television.

As basic phenomena related to vacuum were explored, the unprecedented evolution of technological use of vacuum also began, culminating in the 20th century in various industries, from metallurgy to electronics and aerospace, and basic particle research in high energy physics. In the book, the author describes the history of some of the most essential vacuum technologies used today (thin-film vaporization and sputtering, vacuum metallurgy, microelectronics, semiconductors, domestic household applications of vacuum, vacuum isolation, television... Among basic scientific areas related to vacuum author described topics like X-rays, electron microscopes, accelerators, plasma physics..... Especially in detail, the author of the book discusses

the achievements of Nikola Tesla, in particular, those related to vacuum technology since Tesla spent a short period after his studies in Graz in Maribor. Today's experimental physics cannot be imagined without the use of vacuum technology. Dr. Južnič highlighted the achievements of Professors Peterlin, Osredkar, Blinc and Strnad, who contributed significantly to Slovenian science in the second half of the twentieth century. The author describes the events and the circumstances of the founding and the first years of operation of the Jožef Stefan Institute and some other Slovenian institutes and related organizations like the Institute of Electronics and Vacuum Technique and Slovenian Society for Vacuum Technique.

The author also presented the reflections of Slovenian philosophical physicists (Dolenc, Detela) who touched on "emptiness" in their works, including the author's interesting thinking about vacuum as limits. In the book is demonstrated the Toynebee-Kuhn-Juznic method to illustrate the development of vacuum techniques.

This book is a popularly written scientific presentation of the development of vacuum science and technology in the world and in our country. It should be mentioned that this work also contains many copies of documents on important vacuum devices in Slovenia and worldwide as well as a very extensive list of archival materials that the author has collected for many years in domestic and foreign archives. Access to the Vatican archives and other archives in Europe and America was made possible by the University of Oklahoma, which also supported his research.

The book Vacuum and Vacuum Techniques History, written by dr. Stanislav Južnič is a nice walk through the history of vacuum science in present-day Slovenia territory and the wider neighborhood. We can be grateful to the author who has put a great deal of effort into preparing the great book in a history of "vacuum".

Prof. dr. Janez Kovač

Reviewer's Opinion

Stanislav Južnič physicist and historian, was born in San Francisco. After his schooling in Belgrade and Ljubljana, he graduated from the Department of Technical Physics at the University of Ljubljana and received his master's and PhD degree in the history department of the University of Ljubljana, Stanislav Južnič dedicates the life of the history of Physics and other natural sciences.

In the book *Vacuum and Vacuum Techniques History*, author presents insights into the history of the vacuum research and history of the developments of the vacuum techniques. The book is very comprehensive and extensive and is dedicated to teachers, students, and researchers with technical background. The book contents have mostly been published in Slovenian language in the period 1993-2004 in *Vakuunist*, the bulletin and Journal of the Slovenian Vacuum Society, and in three books written by Južnič entitled *History of Vacuum Research and Vacuum Techniques*, Parts 1, 2 and 3, also published by the Slovenian Vacuum Society (DVTS- Društvo za vakuumsko tehniko Slovenije) in 2004, 2010 and 2017, some contributions were also published in other publications.

His basic field of research is the physics of Carniolian Jesuits and their students seventeenth and eighteenth centuries. He is a researcher from the University of Oklahoma and the Scientific Research centre of SAZU, Ljubljana and examines the European books in USA. In the previous century, the Americans bought a huge amount of old European books, even the books of Galileo with his personal signature are in the library of the University of Oklahoma. Unlike the more advanced USA, there is no chair for the History of Science sciences in Slovenia. At Saint Louis University and at the University of Oklahoma Science Stanislav Južnič studied the works of Carniolian Jesuit-astronomer of Augustus Hallerstein in Beijing (2002), the scientific, military and freemastean activity of Jurija Vega (2003) and the extraordinary successes of the professor of astronomy Gabriel Grubert (2004). At the International Year of Astronomy, he completed his trilogy on the history of accurate science in Slovenia with *Astronomy* (Radovljica: didact: 2008), *Physics*, and *Mathematics* (2009). He is interested in

the links of Ljubljana jesuites with their rich donators' princes of Turjak, Baroni Enberg and the scientific design of the Jesuit Janez Vajkarda Valvasor.

He has published over three hundred scientific works in Slovenia, Croatia, Poland, Serbia, Russia, England, and the United States. Južnič received the wider attention of the media in 2006, when in the Ljubljana National and University library discovered a valuable copy of the book *De Revolutionibus* of the Polish astronomer Nikolaj Copernicus of 1566, which due to the error in cataloguing was stocked and forgotten.

After the first two parts of the history of vacuum exploration and vacuum techniques with collected announcements from years 1993-2004 and 2005-2010, the author Stanislav Južnič prepared the third part of the trilogy: the development of vacuum research and vacuum techniques (at UNESCO-known year dedicated light and related technology, and at the four-century birth of the first Carniolian vacuum of Janez Vajkard of Turjak

The author described in detail the first three decades of Ljubljana experiments with vacuum techniques within the newly established higher physico-mathematical cabinet. The first in historiography was used by the partial Mihael Peternel's description of the initial Bernard Ferdinand Erber devices drawn before the second century, Gabriel Grubert's orders from 1768, the lists that Anton Ambschell signed in 1779 and 1785, and a list of new purchases between March 1781 and March 1782.

The author has thus emphasised the role of Carniolian society and the Society for Agriculture and useful Arts in the financial support of vacuum pumps and other research equipment purchases. From the dynamics of purchases then modern vacuum technology and related experiments and maintenance devices, he attempted to exfoliate the prevailing scientific tendencies and the direction of the holders of the Ljubljana School of Physical-mathematical sciences.

The author also describes the beginnings of the use of vacuum technologies in the Slovenian area of IJS and mentions the Society for the vacuum technique

of Slovenia, which was co-founder of the Yugoslav Vacuum Society (in addition to France, the United states, Spain, Great Britain, Germany, Belgium, Japan, Sweden and the Netherlands) International Union for Vacuum Science, Technique and Applications - IUUSTA in 1958 and in 1962 in today's IUUSTA whose main areas are (see: <http://iuvsta-us.org/iuvsta2/index.php?id=468>) useful science on surfaces: Applied Surface Science (ASS), Bio Interface (BI), Electronic Materials (EM), Nanotechnology (NM), Plasma Science (PST), Surface Engineering (SE), Surface Science (SS), Thin Films (TF) and Vacuum Science and Technology (VST).

Monograph Vacuum and Vacuum Techniques History of the Slovenian author Stanislav Južnič is a historical representation of the functioning of Slovenian scientists and their cooperation with top scientists in the 17th century. and 18th century. At the same time, it shows excellent equipment with research infrastructure and scientific literature, which was collected by scientists in several private libraries. The monograph is fundamental to the further development of the scientific technical scientific area and the importance of presenting Slovenian science achievements in the domestic and international space as well as for the dissemination of new scientific knowledge and scientific culture.

The book contains many copies of documents on important vacuum devices in Slovenia and worldwide as well as a very extensive list of archival materials that the author has collected for many years in Slovenian and foreign archives. Access to the Vatican archives and other archives in Europe and United States of America was made possible by the University of Oklahoma, US, which also supported his research.

The book Vacuum and Vacuum Techniques History, written by Stanislav Južnič is review of the history of vacuum science in Slovenian territory and the west and central Europe. The book is important from the scientific and historian point of view and it worth to be published in English.

Prof. dr. Monika Jenko

I. Prelude: Philosophical Beginnings of (Seemingly Impossible) Vacuum

1 Foreword as Introduction

In front you, my dear reader, you may find a book that was created during the long decades between 1993 and 2020 following the Slovenian Independency. Its parts were published in *Vakuumist*, the bulletin of the Society for Vacuum Technology of Slovenia the newspaper for the vacuum technique and technology, vacuum metallurgy, thin films, surfaces and plasma physics. Some of the studies were adapted in a popular form for the magazine *Life and Tech* (*Življenje in Tehnika*) and others. While the tripartite Slovenian version of this book was published to promote the self-confidence of local Slovenian researchers and users of vacuum technique, the English language translation is here to promote the Slovenian merits worldwide after three decades of hard works.

There are lots of histories of research of vacuum published before this one. They focused technological or philosophical-theological aspects, or both. Why on earth do we need another one? There is one main reason: here, for the first time in historiography, we primary concentrate on the reception of vacuum-related issues in some limited geographical area. That area is called Central Europe, or, more precisely, Slovenia. There is also a nationalistic point in it: we wish to suggest, that all kinds of sciences including vacuum researches were never exclusive domain of Anglo-Saxon part of humans. In this stage of research, it is not quite possible to determine all the merits of non-European

people, while the Slovenian contributions are much clearer. And they are not at all some minor obscurities, as the following narration tries to prove. Regretfully, at this point there is not much to be narrated about the probable vacuum techniques of Aborigines, Pacific Islands people and Sub-Saharan Africans, while just some sporadic information are provided about the Native American lyophilization or lapis nephriticum, Near Easterners' development of Hellenic vacuum and overpressure technologies or the Far Eastern Oriental ideas about vacuums and zeros focused on Kerala areas in India. A little more is provided about Chinese and Japanese early borrowings of European designs of vacuum technologies and luminescence. Those faults are not just the consequences of our Eurocentrism, but also a regretful consequence of the lack of historical research and data about the Non-Europeans worldwide up to now.

Let us introduce the author. As a future physicist and historian, he was born and raised in San Francisco as a typical Frisco kid. The white one with a colored heart. After studying in Belgrade, Ljubljana and Minsk, he graduated from the Department of Technical Physics at the University of Ljubljana at the class of an academician prof. dr. Robert Blinc. He received his master's degree and doctoral thesis at the Department of History of the University of Ljubljana by the academician prof. dr. Vasilij Melik. His postdoctoral positions were all in his native USA. He dedicated his life to the history of physics and related natural sciences. His basic field of research is the physics of Carniolan Jesuits and their students of the seventeenth and eighteenth centuries. He loved to be a researcher at the Universities of Saint Louis and Oklahoma, of the Ljubljana institute of Mechanic, physics and mathematics and the Scientific Research Center of the SAZU as well as the interpreter of Slovenian cultural heritage for Slovenian government as the chief of Slovenian Jesuitical archives. He enjoys studying European books in America as the head of the archives of the Jesuit province of Slovenia and as the interpreter of cultural heritage of Slovenian government. In the previous century, the Americans picked up the huge decisive amounts of old European books, and even Galileo's books with his personal signature are in the library of the University of Oklahoma. In Slovenia,

in contrast to the US, there is no chair for the history of natural sciences.

The fiftieth anniversary of the death of Slovenian inventor of Codelli's Television and the 350th anniversary of the famous Guericke's vacuum experiment in cooperation with Slovenian prince Auersperg was a real opportunity to present our work to the Slovenian readers in 2004. We tried to cover as wide research area as possible, of course, a piece of each of it. For every direction of modern research of vacuum, we have searched for its roots in the past, so there may have been some repetition and intertwining.

We have repeatedly tried to highlight the important contributions of Slovenian researchers. The chapters about individual areas in the book do not follow the chronology of the papers published in *Vakuumist* journal. We decided to prefer the historical method, because the entropic time arrow is a master of us all. Thus, the technical part of this book begins with a longer chapter on the development of vacuum technologies, like pumps and meters, with special emphasis on Slovenian researchers. Then follow the fundamental discoveries in individual fields of research: "cathode ray", vacuum metallurgy and thin films, vacuum balloon, radiometer, thermos flask, bulb, X-ray cathode ray tube, electron microscope, accelerator, cathode ray tube in television, transistor, plasma, and much more. Apart from the radiometer, balloons, thermos, luminescence and few other chapters, everything else is closely related to the use of the vacuum discharges leading to cathode-ray tubes. We discussed the luminescent substances only in so far as we use them for television or computer screens.

After the first part of the History of vacuum research and vacuum techniques in which we collected publications from 1993-2004, its advanced path was available at the second part. We kindly ask you for a blatant benevolent reading.

The second parts of this story were published in 2004-2010 in *Vakuumist* of the Society for Vacuum Technique of Slovenia, the *Journal of Vacuum Science, Technique and Technology*, *Vacuum Metallurgy*, *Thin films*, *Plasma Surfaces*, and *Plasma Physics*. Some surveys were published in a popular

form for the magazine *Life and Tech*; others were published by the Japanese *Historia Scientiarum* and many other newsletters in all continents. But most of the collected texts have not yet been able to see the light of the world in a book form in English language. Therefore, it may seem right to pick them up here in one place. The 400th birthday of the first Slovenian vacuumist, Prince Janez Vajkard Auersperg, is perhaps the right opportunity for this kind of reading.

Two of the discussions in *Vakuumist* were published in cooperation with Vinko Nemanič and Andrej Pregelj. All papers were proofread by Jože Gasperič and edited by Peter Panjan and Miha Čekada. Franc Jurkovič, Albin Wedam and Branko Ozvald told us much about Codelli's television. Most of our ideas were critically examined and supplemented by the oldest Slovenian vacuum researcher, Alojz Paulin. When searching for the right words, I always used a help of my daughter Urška. The Society for Vacuum Technique of Slovenia arranged the printing of our books. Money for research and print was given by the Ministry of Education, Science and Sport of Slovenia and the Mellon Foundation of the Universities of Saint Louis and Oklahoma. For our great encouragement, we are a part of the game which we researched, a kind of guests of honor of inner circle vacuum scientists. We are deeply grateful to everyone. Without their help, the world would be empty as a vacuum.

The vacuum has always been disturbed by cunning people, because the empty space is not something that we can see or touch. Vacuum is also not a completely abstract concept, as it can be pumped out, and we must attribute to it certain physicochemical properties.

In perceiving the vacuum, theoreticians and philosophers on the one hand and practitioners like experimenters, engineers or technicians developed completely different approaches of dealing with each other. For the first, the vacuum is a completely empty space, without any material particles. Thus, about 400 BC, Democritus, whom the Europeans treat as the founder of atomism, taught that all events in nature are an eternal movement of atoms in an empty space. In his statement, the knife cuts the bread because a vacuum is cut out between atoms.

The opposite view was that of Aristotle almost a century after Democritus. In every object, even in the innermost part of matter, Aristotle saw the presence of God; maybe a devil was in the space without substance. The dogma, that nature does not allow the devilish vacuum, sounded nice for the medieval Christian Church. That dogma ruled the mainstreamers until the end of the 16th century. It was reversed by Torricellian famous experiment towards the real vacuum under the influence of imported Indic concepts where vacuum was never a taboo.

For researchers and technicians, however, the vacuum is a state of diluted gas. We can talk about a vacuum when the pressure is lower than atmospheric pressure at the sea levels. By using vacuum pumps, only a "better" or "worse" vacuum can be achieved, since all traces of gases can never be completely removed from the vacuum receiver. The vacuum is evaluated by the pressure or by number of molecules in the volume unit.

Although in the atmosphere, which is the basis for the existence of life on Earth, there are wonderful observable things like wind, rain, cloud formation, lightning, the mysterious atmospheric pressure remained hidden from European perspectives for a long time. It was measured only by Torricellian experiments in 1644. A few years later, the famous Pascal completed Torricelli's experiments and laid down the laws which rule the air pressure. He sent his brother-in-law for the first measurements of the height of the hills with a mercury thermometer-barometer by comparing the pressures at the foot and at the top of the mountain.

In 1654 the German Otto Guericke demonstrated a famous experiment with Magdeburg hemispheres with the help of Žužemberk-born prince Janez Vajkard Turjaški-Auersperg. Around 1737, the Swiss D. Bernoulli explained the gas pressure in a container by the collisions of particles with the vessel wall, thus laying the foundations of the kinetic theory of gases. Significant great progress in the field of vacuum science took place in the second half of the 19th century. Many eminent European scientists of that time tried to discover the elementary particles of electricity by trying to discharge in evacuated tubes. The results of these

experiments were remarkable. In 1852, during the exploration of discharges, the Welshman Grove noticed the sputtering dispersion of metals - i.e. the method of evaporation of metals, which in the form of thin films condenses on a cold basis. In 1892, the famous Edison used this sputtering process for metallizing matrices to make the gramophone records. In 1895, Röntgen discovered X-rays. Two years later, J. J. Thomson "discovered" an electron, and in the same year Braun's cathode-ray tube was born which soon became the basis for television. The last three discoveries were rewarded with Nobel Prizes while Edison or Tesla got none because the technically minded community sharply divided itself into moneymaking inventors and academicians with just sporadic actors active in both areas as William Thomson lord Kelvin. The gap separating scientists from engineers might not be that deep as the Charles Percy Snow's dual cultural gap between sciences and humanities but it is evidently deep enough for unwanted divisions.

The carbon filament lamps, manufactured by Edison in the United States since 1879, produced a powerful impulse for the advancements of vacuum technology. The result of glow discharge research was also a fluorescent lamp, which enjoyed its commercial use only after 1938, on the outskirts of WW2. An important invention in the field of vacuum technology was also a Seebeck-Peltier's thermocouple which gradually replaced clumsy Torricellian mercury thermometers. Dewar designed his first "thermos" flask in 1873.

After the First World War, the quick violent development of electronics began. In the mid-1930s, the use of vacuum expanded into metallurgy. After the Second World War, vacuum technology was an essential tool in the separation of uranium isotopes with thermo-diffusion and in the development of nuclear reactor materials. Vacuum technology was also indispensable in the development of accelerators and electron microscopes. In the 1960s, vacuum technologies enabled the development of lasers, optics, optoelectronics and microelectronics.

Research in the vacuum also made possible many fundamental scientific achievements: detection of isotopes by mass spectroscopy, confirmation of kinetic theory of gases, measurement of

photoelectric emission (photoelectricity), confirmation of wave properties of electrons by observing their dislocation, etc.

New insights about the history of vacuum research and vacuum techniques came from archival studies. Since the 20th century, the vacuum techniques have been practically applied to all fields of natural science and engineering described in this work, in fact throughout the history of physics, chemistry and related sciences. In the first two parts of the trilogy published in Slovenian language, the emphasis was placed on the history of worldwide achievements in the field of vacuum science. In third part, we limited ourselves to describing the achievements of all those scholars who have worked in today's Slovenia in the last four centuries. All of this and much more filled our first two books of the history of vacuum research and vacuum techniques. In the third book, we describe the achievements of those scholars who have worked in today's Slovenia in the last four centuries and who used vacuum in their research. During the review of archival material at home and abroad, we reached many unpublished documents to prove that in today's Slovenia, until the middle of the 19th century, the researchers had developed strong technical intelligence, which was not overshadowed behind their neighbors, but in many ways even overcame them. The secret desire is that these Slovenian scholars, who were mostly members of the "foreign" nobility, would again be declared as "ours". We all think that Slovenian embracement could be right for them. And as the reader of this book can find out, there were many of them. The conclusion is that until the middle of the 19th century Slovenian scholars were not far behind the neighbors and they even exceeded them in many ways. In the turn of political struggles in 1848, the elite, from which they emerged, the nobility, was declared non-Slovenian, therefore a great brain-drain soon began. One of the purposes of this book is that the scholars who worked in the field of modern Slovenia must be once again declared as the Slovenians. This is especially true of the close cooperation between the first prince Auersperg and the inventor of the vacuum pump Otto Guericke, since the prince was born in Žužemberk and spent the autumn of his life in his Baroque palace on the site of today's NUK in Ljubljana.

We do not only talk about who these Slovenian scholars were and what were their achievements. We described and documented them in detail. We learned who were their teachers, classmates, from which textbooks they were taught and what teaching aids they used. Of course, we can find out which books in the field of technology (as well as other areas) they published. We even know who their friends were, who supported them and who were their opponents. It is also very interesting that those scholars already collaborated very intensively with their colleagues on European soil, and even in the wider areas. At the time from the 16th to the 19th century, mainly the Jesuits dealt with science on the Slovenian soil. The natural sciences were only part of their interest. However, this book deals with the whole aspects of their work which is why we are also interested in other areas of science. Since they filled first barometers and thermometers made in Florence in the 17th century with Idrija mercury, we also described in detail who led the Idrija mine at that time, what technologies they used and what kind of education system they had in Idrija. The first vacuum experiments were carried out in Florence with Idrija mercury. We must know that the authorities in Vienna sent the best experts to Idrija to improve the process of obtaining and processing Idrija ore. For example, Inzaghi as the manager of the Idrija mine at the 18th century and his close relative Alessandro Volta among the first supported vacuum novelties in the territory of today's Slovenia. The heads of the mine, especially Abondio Inzaghi and his descendant Franc Janez Inzaghi, the second cousin of the mother of Alessandro Volta, played an essential role in the distribution of Idrija ore. Franc Janez Inzaghi employed his first-class collaborators, including Janez Anton Scopoli, B. Hacquet and the Bohemian pharmacist Ernest Freyer. Alessandro Volta contributed to the progress of the Idrija mine with his exploration of gases. Volta's relative Franc Janez Inzaghi, for his reimbursement, delivered to Volta a hefty amount of Idrija mercury required for production of barometers and thermometers at Volta's new physical laboratory of the University of Pavia, where he received his chair two years after Scopoli. With their knowledge of the distillation and vacuum procedures for the cleaning of Idrija ore, the experts in Idrija also contributed to the good supply of Volta's and Dutch vacuum pump manufacturers, including Musschenbroek who collaborated with

Herman Boerhaave, a teacher of many leading scholars at the Viennese court. The consumption of mercury for scientific purposes was not very great, but it greatly contributed to the prestige of the Idrija mine. Franc Janez Count Inzaghi achieved the decisive success at the end of his leadership of the Idrija mine due to enormous Spanish orders for amalgamation in Mexican and other Latin American silver mines. Due to connections with Inzaghi's relatives, Volta's rechargeable electrophorus and Volta's pistol eudiometer for measuring the quality of air spread remarkably fast, also into a collection of Ljubljana's higher education physics-chemical cabinet. Inzaghi stayed in touch with Volta even after his return to Graz, especially when Volta's wedding took place in 1794.

Our book also contains interesting descriptions of the vacuum measuring devices of Tobias Gruber the brother of the more famous Gabriel Gruber, the builder of the Ljubljana canal and General the Jesuit order. We also examined Tobias' scientific works as the vacuum gauges of his own production at that time were so reputable that he was repeatedly elected as president of the Bohemian Scientific Society, the forerunners of today's Czech Academy of Sciences. The younger brother of the general of the Jesuits Gabriel Gruber was the famous scholar-vacuumist Tobias. We presented Tobias inventions of vacuum measuring devices that were adapted for the field measurements. Tobias' scientific work, and especially handy vacuum devices of his own production, received such a resonance that Tobias was chosen three times for the president of the Czech Science Society. Early in 1804, Tobias Gruber renewed his vows as a Jesuits under the direction of his brother General Gabriel. He researched in Ljubljana and the wider Carniolan areas for four years, together with his brothers Gabriel and Anton who were more closely related to the city of Ljubljana.

We also published many archival documents about Johann Philip Neumann, the first professor of physics at the Ljubljana Faculty of Philosophy who wasn't a monk. He the pioneer of vacuum techniques in Slovenian areas. In addition to scientific discussions, he also wrote several textbooks, and he raised many successful successors. His best student was Janez Krstnik Kersnik (the grandfather of the

known writer Janko Kersnik), who later conducted chemistry-physics lessons in Ljubljana for almost half a century. It is also interesting that Neumann was a close collaborator of the famous composer Franz Schubert. Among the professors of Ljubljana and researchers of vacuum techniques, Neumann is by far the most notable online and in the literature. Therefore, we can only agree that Neumann deserves a kind of memorial in Ljubljana or at least a street with his name.

The archival documents about the first Slovenian aeronaut and balloonist Gregor Kraškovič, published in this book, are also amazing. His pioneering achievements in aviation, as well as in the field of vacuum technology, make Slovenians proud even today. We described in detail the first Slovenian astronaut and beginner of ballooning Gregor Kraškovič. We emphasized the early Kraškovič's experiments on the implementation of a half-century-old idea promoted by A. Kircher's student Francesco Lana Terzi of Brescia focused on the flight under vacuum balloons. The first Slovenian balloonist died in the then suburb of Dubrovnik immediately after the new year of 1823. Complications with his will reveal the complexity of his private life, and even more so his scientific interest in vacuum technique. Although after the completion of higher studies he never fully returned to Carniola, the Slovenians are undoubtedly proud of his achievements.

One chapter of the book is dedicated to the famous physicist Ernst Mach. His father was a landowner in Veliki Slatnik of today's South Slovenia between 1858 and 1879. Ettingshausen's students reshaped many aspects of vacuum techniques, among them Stefan and Mach. Mach designed the first use of flash photography of supersonic missiles, which was carried out for him by Peter Salcher, a student of K. Robida, S. Šubic and A. Toepler. Robida was a pioneer of metal sputtering, while Ettingshausen and Toepler developed modern scientific photography. Both these achievements are used today to take photographs of complex plasma turbulences during sputtering of thin films with a magnetron. Mach's achievements in the photography of supersonic missiles enabled today's studies of plasma turbulences with the fast cameras, which researchers

at the IJS developed together with American colleagues.

The teachings of Slovenian scholars, who in the past centuries marked Slovenian physics, were in steady mutual exchange with westerner advancements. Today's experimental physics without the use of vacuum technique is practically unimaginable. We particularly emphasized the achievements of professors Sirk, Peterlin, Osredkar, Blinc and Strnad as the leaders of others. Nor did we avoid the Slovenian philosophical physicists like Dolenc or Detela, who in their works touched the "voids". We included the interesting thinking about vacuum as a limit. The use of Toynbee-Kuhn-Južnič's method for illustrating the development of vacuum techniques is also a novelty. When we explained the use of vacuum in industrial production, we even included the history of vacuum technology for the preparation of dishes and cleaning. The book contains a very comprehensive list of archival documents collected for many years in domestic and foreign archives. Access to the Vatican archives and others in Europe and America was facilitated by the University of Oklahoma, which also financially supported this research. The book is very conscientious about the Slovenian and English naturalistic technical terminology. The technical terminology was updated to fit this kind of work. We use a juicy language, so the book is well readable. Sometimes we go into a detailed description of some of the peripheral events, which gives the narrative extra authenticity and consequently makes it no less professional. If we limit ourselves to a factual description of professional achievements, the book would have lost much of its readability. The narrative unveils many attractions. So, for example, we find that in 1894, chemist Swaty put into operation a Maribor grinding plant and that Kager metal workshop from 1737 was the predecessor of today's Maribor Foundry. We also learned that the Ljubljana watchmaker and electro-mechanic Josip Geba installed his phone in the fire monitor tower of Ljubljana castle at the premises of the Ljubljana Fire Brigade on 14 January 1882. Interestingly, the famous prof. Simon Šubic then boldly doubted this novelty. The book also tells us that Jožef Murko's money loans, mediated by the law student, later military priest Milan Panajotović, pushed Tesla into debts which ruined Tesla's studies in Graz. We deal with the achievements of Nikola

Tesla, especially those related to the vacuum technique. Tesla was "appropriated" by Slovenes because he spent in Maribor a shorter period after his unfinished studying in Graz.

We also learn from the book that in the 18th century, the "Réaumur Degrees" was used to measure the temperature, and the line unit (approximately 2.2 mm) was used for measuring the length, while with the eudiometer (which measures the change in the volume of gases during the chemical reaction) our academic ancestors measured the "goodness" of the air. This research is a wonderful walk through the history of science in the space of today's Slovenia and beyond. We can only be grateful to those who made a lot of effort in preparing the book because they enriched us for many insights that we would not be able to grasp otherwise.

We studied the works of the Carniolans including the astronomer Hallerstein's successes in Beijing (2002), Jurij Vega's scientific, military and masonry activity (2003) and the extraordinary success of Vega's professor of astronomical-nautical sciences Gabriel Gruber (2004). At the International Year of Astronomy, we completed another trilogy on the history of exact sciences in Slovenia with Astronomy (Didakta, Radovljica, 2008), Physics, and Mathematics (2009). We are interested in the connections between the Jesuits of Ljubljana and their wealthy patrons, the Auersperg princes, Erberg barons and the scientific ideas of the Jesuit student Janez Vajkard Valvasor. We published over one thousand scientific works in Slovenia, China, Japan, Hungary, Croatia, Poland, Serbia, Russia, England, Austria, Germany, Italy, Australia, Spain, Catalonia, and the USA. In 2006, we discovered the second edition of Copernicus' book, which for centuries lay forgotten in Ljubljana.

After the first two parts of the History of Vacuum Research and Vacuum Techniques with collected publications from 1993-2004 and 2005-2010, the third part of the trilogy was finally available with all their English translations included. That book contained eight chapters: (1) Introduction to research and concept of vacuum; (2) Reflections on the voids among Slovenes once and today; (3) Experiments in vacuum for the first time; (4) Vacuum pumps as standard experimental tools for enlightenment; (5)

Vacuum becomes part of the electrical industry; (6) vacuum for modern Slovenes; (7) Vacuum Philosophy; (8) The leading Slovenian vacuum researchers.

Hopefully, the third part will not lag much behind his predecessors. The stories of third book were mostly published between 2011 and 2016 in *Vakuumist*, the newspaper of the Society for Vacuum Technology of Slovenia, the *Journal of Vacuum Science, Technique and Technologies*, *Vacuum Metallurgy*, *Thin Films*, *Surfaces and Plasma physics*. The versatility of *Vakuumist* editors dr. Peter Panjan and dr. Miha Čekada, the President of DVTS dr. Janez Kovač and the reviewer Monika Jenko was decisive. For this edition, we sorted our published articles into a convenient timetable, interconnected them, and tried to conceive them so that the reader receives the impression of the desired integrity of the events and their connection with the modern everyday life. We dedicated the third book to the 250th anniversary of the birth of the vacuum balloonist Kraškovič with his pioneering achievements in aviation, as well as in the field of vacuum technology. They still delight us today.

We proudly described the life and work of the first Slovenian vacuum researcher, Janez Vajkard Auersperg, and his Ljubljana disciple Janez Vajkard Valvasor. We detailed the teenage years of a poly-historian Valvasor, described his teachers and important scholars who participated in the research, especially their books published in the field of technical sciences. We especially emphasized the most important Jesuits of Ljubljana in networks of Janez Vajkard Prince Auersperg, who completed his basic education in Ljubljana and continued his studies in Germany and then in Italy. We presented the work of his teacher Ferdinand Montegnana, who also studied in Italy. Further advances of the Slovenian share in the research of early steamships were conducted under the leadership of the Jesuit Gruber. We also extensively described the work of Rudjer Bošković, who characterized his physics with a description of the vacuum and visited Ljubljana at least on three occasions. We described the operation of Kobencel's Carniolan-Gorizia family with a special emphasis on their cooperation and friendship with Bošković and the collection of books on vacuum techniques and the establishment of private libraries.

All this and much more was achieved by the penultimate generation of Kobencel led by the Brussels-appointed Minister for the Habsburg Netherlands, Janez Karl Filip Kobencel. His first-rate Brussels library with technical-vacuum manuals and the Janez Karl Filipe Kobencel's collection of paintings paved the success of his pursuits in the line of Freemasonic freethinkers of the then Europe, whose interests were close to the vacuum, especially after the ballooning of Freemasons Montgolfier. Janez Karl Filip Kobencel did not read his books about the vacuum as his secretaries read and commented the novelties for him. We described his actions and failures at a time when good and timely information increasingly conditioned his correct economic interventions in the vacuum and other technologies of today's Belgium and Luxembourg, which Ljubljana native Kobencel managed for a decade and more under the name of the Habsburg Netherlands. We described in detail the first three decades of experiments with vacuum techniques in the newly established higher education physics and mathematical cabinet of Ljubljana. As the first in historiography we used Michael Peternel's partial description of the initial collection of devices of Bernard Ferdinand Erberg, compiled a quarter of millennia ago, commissioned by Gabriel Gruber in 1768, updated and signed by Anton Ambschell in 1779 and 1785 with lists of new purchases between March 1781 and March 1782. We thus emphasized the role of the Carniolan Society for Agriculture and Useful Arts in the financial covering of the cost of vacuum pumps and other purchases. From the dynamics of procurement of modern vacuum technology and related devices for experiments and from their maintenance, we learned all about the prevailing scientific tendencies or orientations of the holders of the then Ljubljana teaching chairs of physics and mathematics.

We described the beginnings of the use of vacuum technologies in the Slovenian space at the Jožef Stefan Institute and at the Society for Vacuum Technology of Slovenia, which was a co-founder of the Yugoslav Vacuum Society and (together with France, the United States, Spain, the United Kingdom, Germany, Belgium, Japan, Sweden and the Netherlands) of the International Association for Vacuum Science and Applications - IOVST in 1958 and of today's IUVSTA named on 8th December

1962. The main areas of IUVESTA are: the Applied Area Science (ASS), Phase Boundary with Biological Material (BI), Electronic Materials (EM), Nanotechnology (NM), Plasma Science (PST), Surface Engineering (SE), Surface Science (SS), thin films (TF), and vacuum science and technology (VST).

The development of vacuum and vacuum techniques provides a historical overview of the operation of Slovenian scientists and their collaboration with top scientists in the 17th and 18th centuries. It shows contemporary excellent equipment with the research infrastructure and scientific literature collected by the then scientists in several private libraries. This monograph is of fundamental importance for the further development of the field of history of science and technology and is important for the presentation of Slovenian scientific achievements in the domestic and international space, as well as for the dissemination of new scientific knowledge and scientific culture.

The vacuum has always been the central concept of mathematical-technical sciences, and it has since been a puzzle of philosophers and theologians. The modern astrophysical theories are full of vacuum, just like most of their predecessors. Years ago, my undergraduate and postgraduate professor Andrej Ule said: "For me, there is still a question, the vacuum is the absence of - what? Once we know how to respond, we really will know something. Until then, we have only assumptions." The vacuum is nothing in its own way, and somehow it seems empty. At the same time, however, the vacuum remains a relatively popular puzzle of the last millennia, while its usefulness is sufficiently recent, quite clear and of utmost value. Just over ten generations separate us from the first barometer that has emerged as a surprise outside the circle of Galileo's students and especially among the Jesuits: although it was not clear what is in it, it became obvious how useful and even funny can be that supposed zero matter in a vacuum. For two centuries, a useful vacuum was limited to scientific meters and gauges. Therefore, it may not have been so ennobling in the eyes of the Chinese Emperor as other European novelties, which were largely brought to him by Hallerstein from the sunny sides of Alpine mountains of Carniola. The vacuum

technology has indeed worked out in steam engines, where the lowered pressure of vacuum was turned into an overpressure. Then, with the improved glass technology, the electrical engineering suddenly gave birth of electrical discharges turned in the cathode-ray tubes' electronics, which in the following decades developed tools for quantum-mechanical discoveries ranging from the electron and X-rays to accelerators. On the other hand, this emptied tube became the foundation of modern lighting, storages of food, productions of new materials, nanotechnologies and the entertainment industry from television onwards. A century ago, people became aware that mercury from the barometers was unhealthy dangerous and recently the empty vacuum was removed even from the most of modern displays. Only in bulbs this congestion of vacuumed zero is still almost untouched, since only the light bulb remains like that of Edison's for century and a half, probably just because Edison was such a genius himself. Also, the vacuum increasingly protects our food. Above all, vacuum somehow searches for and finds many new areas of application. It is nothing, but it should not be given for nothing or even to despair.

2 Reflections on Emptiness among Slovenes Once and Today

Contrary to modern economic problems with always stronger doubts about the ability of Slovenes, the areas inhabited with Slovenes used to be active part of the scientific pursuits in past centuries. If the perspectives are not the best today, it was not so in the previous centuries. The past inhabitants under the southern slopes of the Alps were not far behind their neighbors who today earn much more than the Slovenian economy permits. Once the inhabitants of modern Slovenia even surpassed their neighbors. The merits of Slovenian ancestors seem to be hidden, especially because many of them are somehow inadvertently declared as foreigners. With their gradually lost democratic elections after the Spring of the Nations, in the aftermath of the year 1848, one of the worst brain drains damaged these southern Alpine neighborhoods, worse than those of Črtomir, Protestant, Jesuit Gruber, the emigrations of the poor to America in 19th century or in modern days. In the spirits of political struggles whose first victim is always the truth, the noble elite of territory settled by Slovenians was suddenly declared as foreign. This unreasonable proclamation then became even more silly when applied to the ancestors of Slovenian political opponents, and thus the Slovenes not only remained without their nobility, but even without the scholars of the past centuries, which can be much more painful. This book serves its purpose also by re-proclaiming the former inhabitants within the boundaries of modern Slovenia as Slovenians, since they are not guilty of anything even if their great grandchildren were subsequently expelled as the Slovenian "ethnic national enemy".

The national colors are only one side of the present work, by no means the most relevant. Much more fresh wind brings the search for legitimacy of the development of vacuum technologies as a model for the development of all sorts of sciences. The penetration of scientific and technical innovations into the space between the Adriatic, the Alps and Pannonia, their acceptance and their feedback return effect, especially focused on Slovenian western and

northern neighbours, is already well and thoroughly studied in this book, so that it can be used for the development model of all sciences as concisely described in the concluding chapters as a Južnič-Kuhn-Toynbee model.

3 No Experimental Tools for Vacuum

3.1 Vacuum: Concept Development

The issue of vacuum was important in ancient and medieval philosophy. In last four centuries, the technology of vacuum developed from the limited laboratory interest to a strong research and technological tool for nanotechnologies. In modern theories, the vacuum takes basic role. Therefore, the new millennium is surely an opportunity to see the way out from the questions: “What the hell we are missing inside the vacuum?”

3.1.1 *The Vacuum in Antiquity - Introduction*

The modern name of the empty is derived from Latin and not from the Greek "kenon (κενός)", although the roots of modern terms in science are mostly Greek. The reason for the exception may be in the wrong sound of the Greek word or in the prevailing rejection of the existence of a vacuum in ancient Greece.¹ Above all, there might be a very simple ignorance in the background, since many early practical vacuum explorers in the 17th century did not know Greek language well enough.

3.1.2 *Aristotle*

Aristotle's teacher Plato defended the existence of invisibly small atoms without describing the vacuum between them, contrary to Democritus or Epicure. The Platonists had a vacuum for the element of disorder, which the great Demiurge (δημιουργός dēmiourgos) did not use in his organization of nature.² It should therefore be a possible but non-existent element. A similar approach was used by the Jesuits later in their disputes against the vacuum in the barometer. The omnipotent Demiurge of Jesuits was certainly able to create the vacuum, but did he bother to do it?

Aristotle denied the existence of an empty vacuum,³ much like his teacher Plato and before them Parmenides. The properties of the moving body and the properties of the medium influenced the speed of movement in Aristotle's system. In the same environment the body with a greater "force of motion" achieved its working space faster on its way through the substance, which allowed it to increase speed. In an empty substance, there is no resistance of the media agent. Therefore, in emptiness, all bodies should move equally fast regardless of the "force of motion"; but this did not seem clever to Aristotle. That is why he rejected the emptiness, which does not resist the movement, as he saw the possibility of infinitely high speed in it. He designed four basic elements with the natural direction of movement upwards or downwards, depending on their density. Unfortunately, in a void, the poor philosopher did not find a point of reference, according to which he could define the difference in the direction of motion.⁴ So, his strange hostile vacuum rebuffed him on that side. He criticized the defenders of the empty including Leucippus, Democritus, Eleatics Melissos of Samos (Μέλισσος ὁ Σάμιος), Pythagoreans, and the Pythagorean from Croton (Crotone) in South Italian Calabria Xuthus alias Bouthus.⁵ Later, the physical and philosophical atomists of the 19th and 20th centuries cited primarily Democritus and Leucippus.

Peripatetic from the Jesuit schools declared the vacuum to be a contradiction by itself. So, it sounded especially to them in their medieval Latin; they baptized vacuum as the locatum sine loco, which was certainly deeply illogical. The modernized Galileo's Italian physicists preferred Italian language in Florentine court to avoid such a language conflict which was severely dissected by Valeriano Magni with the title of his work "Locus sine locato" in 1647. This was supported by Galileo, who likewise loved to distort the thoughts of the great teacher Aristotle. Such semantic games were never alien in the histories related to vacuum with the English language light-weight attached to the light of optics included. The language which we use determines our perceptions: the best way to stay objective is to use several different languages.

³ Aristotle, 1987, 98–100.

⁴ Sparnaay, 1992, 12; Podolny, 1986, 19, 21.

⁵ Aristotle, 1987, 97, 98, 99, 106.

¹ Podolny, 1986, 16–17.

² Sparnaay, 1992, 11.

3.1.3 *Ancient Researchers after Aristotle*

The physicist Strato of Lampsacus lived between 340 and 270 BC in Aristotle's Athens, where he listened to Aristotle's peripatetic lectures in Lycée. He described a process for obtaining a vacuum; contrary to Aristotle, he ignored the assumption of two types of vacuum. Heron of Alexandria, a contemporary of Jesus Christ nearby somewhat in eastern side, focused on the engineering scholarship. He made a "steam turbine" for sputtering the water vapor in the temples. He followed Aristotelians to assume that there was no empty space in nature. Nevertheless, in two parts of his "Pneumatics (Πνευματικά)", Heron has practically and theoretically proved that a vacuum can be created in closed containers; human products should be subject to different laws than the products of (God's) nature.

Around the year 1300, the term "horror vacui" began to scare common folks. At the same time, Aristotle's active role of the media in the motions aroused serious concerns in Paris and Oxford in the fourteenth century.⁶

3.2 **Early Thinking about Empty among Slovenes**

3.2.1 *Empress's Thin Films*

The westernized peripatetic ideas about vacuum and their criticism quickly penetrated in the areas inhabited by Slovenes. Not just ideas: even the practices of producing new substances and thin films soon became common among the wealthy on the southern sunny slopes of the Alps. The empress Barbara of Celje was the very best of them all. As an able pioneering researcher of new materials, she begins our story with her wit, while the other excellences of her gender will end it about thousand pages further. Between them, most of our subjects are men.

Herman of Carinthia opened the door into Mid-European minds for Eastern wisdom's expansion, but many centuries passed before folks knocked on

them. The locals were much too busy by keeping themselves alive. No times for contemplations. Enters Barbara. Wealthy. Adorned in public. Backbit in shadows. Herman's doors of knowledge opened widely for her grace never to close again.

No matter what's ones' opinion about her husband, Melania Trump seems to be the last among Slovenian-raised rulers. This is the story about the first ones named Anna (1380/88-21. 5. 1416) and her sister Barbara (1392-11 July 1451) of Celje (Cilli), who ruled six centuries before Melania. The reader is to decide which one was better.

All three chicks were the natives of Lower Styria where they grew up. The first two were a stepdaughter and daughter of the ambitious upstart Hermann II count of Celje (1365-1435), but they soon surpassed him as the girls with their own strong minds, as well as with their own powerful courts. Slovenia never had a king of its own, but that same land certainly nursed a handful of successful queens, empresses, or great governesses even if Slovenia not really looks like the feminist or Amazons' country. Why?

Because of the total lack of their own kings, the Slovenians borrowed the Hungarian one Matthias Hunjady Corvinus transformed into Slovenian king Matjaž. The king Matjaž is supposedly residing in a Carinthia Peca Mountain with his huge beard growing around the hills in Archimedean spirals while he is waiting for his new opportunity to save his Slovenes (again). Matthias helped his brother to kill Barbara's nephew Ulrich while Ulrich became the very last representative of Barbara's Celje house. Matthias and Celje princes were sworn enemies, but they both became the leading heroes of Slovenian glorified faked past. There was nothing Slovenian in Matthias except that he successfully fought against his contemporary Habsburgian ruler which makes Matthias a kind of local oppositional leader. His Slovenian fake story is typically domestic for Balkan, just like the one of the heroic prince-king Marko (Mrnjačević) whose two younger brothers Andrijaš and Dmitar migrated to serve under Barbara's husband in 1394, while Marko remained the Turkish vassal.

⁶ Asimov, 1978, 22; Podolny, 1986, 23; Sparnaay, 1992, 14.

The centres of knowledge change. They pick up one place for a while, get exhausted, and transfer their networks to the places which seemed very barbarous just a moment before. The spreading of science is a kind of democratic process although no contemporaneous literati were ever aware of that because they imagined that their central position in erudite networks might be eternal. It proved not to be.

The Styrian settlement of Celje was such a centre once despite of Piccolomini's critiques. The settlement nursed its privileged position for about a century, and, suddenly, its times were over.

3.2.1.1 Celje (Cilli)

The thousand inhabitants of the market Celje were glad when their rulers moved from the huge southeast upper castle to their more comfortable lower city castle. They used to tell each other in secret when their rulers were not at sight: "Well, if I had to pay so much taxes to make my landlords fat, it is still much better to have them around to watch their bellies grow, than to let them stay in that hill castle and see them once a month." The folks laughed: "You are certainly right. Now that we have our wealthy landlords here among us, they are much more like ones of us." Some suspicious guys did not agree very well: "Take care about your wives and daughters, my dear fellows. The sexual appetites of those landlords of ours has no limit, and now that they live so close to us, there is no obstacle to stop their megalomaniac wishes... Many of your offspring might have the blue noble blood suddenly!"

For the teenager kids and especially daughters of the landlord Herman II of Celje the funny busy market called Celje was far more interesting than the huge boring castle on the nearby hill. All eight of them kids used to play together despite of the dozen years of difference between their ages. There were no apparent competitions between Herman's legitimate, illegitimate, or adopted offspring. The oldest Frederik was the leader of them all including two kids named Anna, two Hermans, Elizabet, Ludvik, and the youngest Barbara. They loved to play on the banks of Savinja river and in the old metallurgical areas nearby. Barbara was always finding the

exciting pieces of minerals in the pebbles she passionately collected: "Look at those! What a nice pebble. The sun shines through every detail of its structures to make its surface shine like a thousand broken mirrors. What might be the composition of the pebble which makes it so strange? Which compounds does it contain? Please help me to carry all those pebbles back home to our Celje castle and I will ask our father's personal astrologer to perform some alchemistic analysis of the structure of the pebbles. It is quite possible that some precious metals are involved! Those Celje jewellers could put the pieces of those pebbles in my diadem for my birthday present, don't you think?" Frederik laughed, while he was getting used to the extravagancies of his little sister.

Anna lost her father very early while her mother Anna quickly remarried with Ulrich duke of Teck in Swabia.⁷ Barbara of Celje was born around 1392 in Celje as the youngest daughter of Hermann II, Count of Celje, and Countess Anna of Schaumburg. Barbara's own mother Anna von Schaunberg died when Barbara was only four years old. Anna von Schaunberg's widowed husband Herman II refused to remarry because Anna gave birth to quite enough of his offspring and he preferred to keep as many mistresses as possible. The feminine mother's hand was missed in the developing worldviews of his children which had huge consequences on their future sexual affairs. Barbara was sad as an orphan: "Dear Anna, you've lost your father as a little kid, and I also have lost my mother before I barely knew her. You are luckier because our father Herman adopted you and he is like a real father to you. Me, I have no such luck. There will be no mother to adopt me, that's out of a question, just look at the eyes of our father Herman and you will easily find up why. He's not going to find us a stepmother, that for sure. I'm orphaned, eternally orphaned, deprived of my mother's care, and you are not you are naughty happy princess of Poland!" "Do not get upset, Barbara. You are not orphaned at all. If you wish, I could play you mother for a while. It's going to be fun."

⁷ Ulrich duke of Teck died in 1432 (Lukanc, Maja. 2016. Ana Celjska. Celje: Pokrajinski muzej, 12); <http://genealogy.euweb.cz/baden/baden1.html>

3.2.1.2 Krakow

The new century proved to be the turning point for both youngsters. The widowed Polish king needed Anna's royal genes to legitimize his rule. The widowed Hungarian-Croatian king needed the support of Barbara's father to get the Bohemian and imperial crown. Both grooms were a quarter of century older than their brides, but the call of politics was far stronger than any love scruples even if the Polish king did not find Anna particularly attractive. In 1401 both girls left the banks of Savinja river forever. Their dog Urs was extremely sad because he was not allowed to accompany his beloved girls to their new destination. With his deep instinct, Urs even felt that he would not be very welcomed in his hut by the lower Celje castle without his girls and their mutual care. To avoid his dangerous destiny, Urs wandered around the market Celje a lot. Urs was barking sadly while the Celje counts Herman II and his eldest son Frederik accompanied their Anna and Barbara to Krakow. The summer was there while they rode northwards some 750 kilometers in a huge wealthy caravan. They passed Graz and Vienna with prolonged stays and had a lot of fun. They arrived in Krakow on July 16, 1401. By the city gate the Polish king Władysław II Jagiełło and his suiters greeted them. Władysław II Jagiełło used to be in eternal quarrel with Barbara's fiancé the Croatian-Hungarian king Sigismund of Luxemburg who tried to get Polish throne previously. Władysław was therefore not extremely happy to greet the fiancé of his former sworn enemy Sigismund together with his own fiancé,⁸ but the Celje counts had their own interests in playing the intermediate to soften the royal quarrel.

In any case, Barbara urged her fiancé Sigismund of Luxemburg to marry her as soon as possible because Barbara just couldn't stand the fact that Anna outran her in marriage and children productions. In November 1405, probably in Croatian city of Krapina of the possessions of Barbara's father,⁹ still teenager Barbara married Sigismund of Luxembourg, the king of Hungary with Croatia

included. Soon afterwards she was crowned as the queen of Hungary. The grandchildren were not Barbara and Anna's primary concern although Barbara's only grandson Ladislaus V the Posthumous later became the famous medicine-man as king of Croatia-Hungary and Bohemia, adorned with his court astrologer Georg von Peurbach¹⁰ who predicted almost all royal motions. Barbara's favourite was George Gemistus¹¹ with his heretical Platonist teachings based in Florence, but she preferred to get her astrological predictions based on then popular twelve houses fundament from Johannes Gmunden and Heinrich von Langenstein.

Anna went to Krakow monastery of the nuns of Poor Clares (Order of Saint Clare) of St. Andrew the Apostle to learn Polish language for the needs of her traveling fiancée,¹² while Barbara was also educated as the traveling fiancée of her eternally journeying royal groom. Barbara and Anna's grooms decided to travel as much as possible.

Among Barbara and Anna's Krakow classmates in Krakow academy recently restored by Anna's husband was John Cantius¹³ who studied the impetus of Parisian university erudite Johannes Buridanus.¹⁴ They liked to have their joint long discussions although they were not all on the same frequency with their thoughts.

Their mutual teacher Andrew Wezyk nicknamed Serpens¹⁵ sometimes joined their debates in their Krakow headquarters. Serpens got his bachelors' degree in Prague in 1397 and he upgraded it with his masters' degree of arts in Krakow in 1402. Serpens was the clear total supporter of Averroes and Buridanus, while Serpens later became a Dominican. Andrew the Serpens was much more on the side of John Cantius during their quarrels, but he was clever enough not to oppose the almighty queens: "Do not get upset, my dear queens. John Cantius has his right path and you also have your own. John Cantius'

¹⁰ Purbach, Peurbach, Purbachius (May 30, 1423 – April 8, 1461).

¹¹ Γεώργιος Γεμιστός, Plethon, Pletho, 1355-1452/54.

¹² Lukanc, Maja. 2016. *Ana Celjska. Celje*: Pokrajinski muzej, 22.

¹³ St. Joannis Cantii, Jan z Kęt, Jan Kanty, 23 June 1390 – 24 December 1473.

¹⁴ Johannes Buridanus (c. 1295 – 1363).

¹⁵ Andrew Wezyk nicknamed Serpens (1377-1430).

⁸ Rakovec-Felser, 2013, page 41; Lukanc, Maja. 2016. *Ana Celjska. Celje*: Pokrajinski muzej, 10.

⁹ Katanec, Sara. 2014. *The Perquisite of a Medieval Wedding: Barbara of Cilli's Acquisition of Wealth, Power, and Lands*. MA thesis, Budapest, 30-31, 44, 74.

future is the future of the truth-seeker, just like mine. We are researchers. The destiny of a queen is to rule, not to research. The knowledge is the highest goal of them all, but John Cantius' path to the wisdom is not the only one. You, the queens, you have your own pursuits to knowledge you need, but please be so kind to provide the material support for us, the poor lovers of sciences."

Barbara and Anna understood well Andrew Wezyk Serpens' applications and tried to help. The great opportunity soon emerged. The young queens clearly realized that Barbara and Anna's Krakow knowhow was based on the optical teachings of the Paduan University student the Pole Witelo.¹⁶ What the Krakow university needed was a strong well equipped group of professional astronomers who could support Barbara and Anna's thirst for astrological knowledge based on their model Herman of Carinthia. That was not all they needed, also the observational astronomy should be practiced just like elsewhere in Europe, and as they recently heard, also in Ulugh Beg's Samarkand and in China. The young ladies made a great plan to search for the wealthy local individuals why would be willing to pay the price which was by no means the small one. Barbara and Anna courted well the wealthy Krakow burgher Jan Stobner¹⁷ who graduated in Prague in 1379. "Dear Jan Stobner, we are so pleased to have you in Krakow. So much pleased indeed. There's a way to make your name known for eternity, for all Krakow citizens to come. Please be so kind and put some money on disposal of our new planned university chair where the secrets of astronomy and astrology will be hunted in mathematical ways!" Jan Stobner's soul quickly melted on those nice female sounds, and the accompanying secret additional unspoken beautiful girl's promises: "My honourable ladies! A man must be made of stone not to fulfil the demands of such a nice bunch of young queens as you are. All I have is on your disposal, my ladies, all my possession down to the last coin in my treasuries. We will make the Krakow mathematical stars-researchers the best worldwide, I assure you!" Jan was so pleased with the funny girls and their astrological pursuits that he donated his own funds

for the Krakow Chair of Astronomy and Mathematics. In 1402/1405 his generosity founded the prestigious chair which soon attracted many scholars,¹⁸ just like Anna and Barbara planned.

Besides astronomy, there was another important point that made Krakow university extremely attractive as Barbara and Anna soon figured out. Together with many others of their social class, Barbara and Anna initially supported the ideas of Jan Hus. They sounded nice, just like all ideas do, until they are endorsed by the massive movements of all kinds of folks. The nice sounds of Hus's ideas suddenly become something very subversive which questioned the very fundament of their queens' networks and that aspect of Hus' teaching soon confused and feared Barbara and Anna. The great new advantage of Leipzig and Krakow university was its ability to oppose Jan Hus' novelties which attracted Hus' learned enemies from Prague who were not quite fans of Hus' priorities put on Czech language. One of the best of them was Andrew of Kokorzyn.¹⁹ He studied in Prague to get his bachelor's in 1399 and masters in 1402 under the dean of faculty of arts and the rector in 1402-1403 named Jan Hus.²⁰ In 1402-1403 with final split on 18 January 1409 John Wycliffe' teaching in Hus' interpretation alienated literati who were not Czechs from Prague Charles' university. Hus was not Andrew's favourite, therefore Andrew left for Krakow where he became the dean of the faculty of arts. He lectured about physics in 1406-1407 and commented Aristotle's achievements.²¹ Andrew shared his feelings with Piotr Wysz Radoliński Leszczyc²² who studied in Prague and Padua. From 1391 Piotr served as a chancellor in the court of the queen, and he was appointed Bishop of Krakow on 4 December 1392, soon after Barbara's birth. In 1397 he co-founded the Department of Theology in Krakow and served as the first chancellor of the university established in 1364. Stanisław of

¹⁶ Erazmus Ciołek Witelo; Witelon; Vitellio; Vitello; Vitello Thuringopolonis; Vitulon; Erazm Ciołek, 1230 Legnica in Silesia-1280/1314.

¹⁷ Jan Stobner (1360–1405).

¹⁸ Paul Knoll. 2016. "A Pearl of Powerful Learning": The University of Cracow in the Fifteenth Century, 373, 376, 559.

¹⁹ Andrew of Kokorzyn (1379-1435).

²⁰ Jan Hus (c. 1369 – 6 July 1415).

²¹ Paul Knoll. 2016. "A Pearl of Powerful Learning": The University of Cracow in the Fifteenth Century, 349.

²² Piotr Wysz Radoliński Leszczyc (circa 1354-30 September 1414).

Skarbimierz²³ was the rector after him as he took over his ruling rector's stick in 1400, while their colleague Paweł Włodkowic²⁴ also used to be a distinguished scholar, jurist and rector.

Barbara's best Krakow astrologer was the sympathy of her royal mother and friend of Anna's stepson the Bohemian and Hungarian-Croatian king Władysław III.²⁵ His name was Henricus Bohemus²⁶ which indicated that he was a kind of Czech. Henricus Bohemus was experienced in geomancy but he got imprisoned for several years in Krakow as a Hussite and possessor of necromantic books. The similar evil destiny dogged Barbara's Krakow acquaintance Gajusz as well.²⁷

3.2.1.3 Prague

Their Krakow drunken scholarly funny parties all to soon ended for Barbara and she had to leave Anna. Barbara had to join her royal groom and to settle in the appropriate queen's castles of the nearby kingdoms of Bohemia and Hungarian North Croatia. Once settled in the golden Prague, Barbara quickly learned Czech language and became much more popular in locals Czech speaking networks²⁸ compared to her husband who was widely seen as the traitor of Hus in the Council of Constance. Barbara did not support the extreme Taborite wing of Hussite parties, but she was able to find supporters among the more moderate Hussite folks of their Utraquists' party. Barbara preferred to use her royal Bohemian or Hungarian-Croatian titles to the imperial ones which she never consumed;²⁹ that choice also made her popular in the areas where she

was the crowned queen. She was no Hus' traitor herself, she spoke Czech language fluently, and most of all, she was beautiful. All that combined with her wealthy occult researches provided the basis for her extreme popularity among the common folks as well as among the leaders in Prague. Her alchemistic networks in golden Prague became the prototype fulfilled two centuries later in the Prague court of Rudolf II with his employees including Tycho Brahe and Johannes Kepler.

Barbara missed Anna a lot. To fill up Anna's place in Barbara's heart, Barbara's main Prague female friend became the widow of her husband's stepbrother Vaclav of Luxemburg.³⁰ Her name was Sophia von Bayern-Munich³¹ and she was a decade and half Barbara's elder. Sophia also supported Jan Hus together with her husband until the pope banned Hus in 1410 to prove to all the infidels that there might be something subversive in Hus' seemingly good-mannered teachings. Sophia used to accompany Barbara during her travels as the somewhat special member of Barbara's court.

Barbara's alchemistic research lead her interests into the investigations of all kinds of substance including the gunpowder used for warfare and especially deeply misused by her husband's sworn enemy Žižka's Hussites. Barbara's favourite warfare expert used to be Konrad Kyeser³² who inscribed his nicely illustrated *Belli Fortis* full of alchemistic and magic visions to misguide the enemy in 1402-1405. Konrad wrote down his ideas during his spare times when Barbara's husband exiled him from Prague to his hometown of Bavarian Eichstätt north of Munich and Ingolstadt. Kyeser's novelties failed to distinguish himself during Barbara's husband and father's lost battle of Nicopolis in 1396 which made Kyeser quite unpopular,³³ but Barbara still admired his prophecies.

Barbara was the youngest daughter of Herman II of Celje and Anna of Schaunberg, and Anna was her

²³ Stanisław of Skarbimierz (1360–1431, Stanislaus de Scarbimiria).

²⁴ Paweł Włodkowic (Paulus Vladimiri, ca. 1370 – October 9, 1435).

²⁵ Władysław III Jagiełło (1424–1444).

²⁶ Henricus Bohemus (died after 1440).

²⁷ Rakovec-Felser Zlatka. 2013. Na valovih sreče in pogube. *Kraljica Barbara Celjska*. Maribor: Pivec, page 282-283, 290; Benedek Láng. 2010. *Unlocked Books: Manuscripts of Learned Magic in the Medieval Libraries of Central Europe*. Penn State Press, 69, 218, 225.

²⁸ Žižek, Aleksander. 2015. *ABC Arhivska Barbara Celjska*. Celje: Zgodovinski arhiv/Pokrajinski muzej, footnote 2; Fugger Germadnik, Rolanda. 2010. *Barbara Celjska 1382-1451*. Celje: Zgodovinski arhiv/Pokrajinski muzej, page 20.

²⁹ Fugger Germadnik, Rolanda. 2010. *Barbara Celjska 1382-1451*. Celje: Zgodovinski arhiv/Pokrajinski muzej, page 20.

³⁰ Vaclav of Luxemburg (Wenceslaus IV, 1361-1419).

³¹ Sophia von Bayern-Munich (1376-1428) (Fugger Germadnik, Rolanda. 2010, *Barbara Celjska 1382-1451*. Celje: Zgodovinski arhiv/Pokrajinski muzej, page 9).

³² Konrad Kyeser (Conrad Keyser, 1366–after 1405).

³³ Benedek Láng. 2010. *Unlocked Books: Manuscripts of Learned Magic in the Medieval Libraries of Central Europe*. Penn State Press, 211-212.

adopted sister as well as her second cousin, daughter of Herman II's first cousin Wilhelm who died in 1392.³⁴ As all other Herman's children, Barbara too had a very special place in his scheme for the rise of the Celje dynasty. However, her father probably never imagined she would go all the way to become the wife of the Sigismund of Luxembourg, the Holy Roman Emperor. Herman II of Celje most likely started to put together the pieces of the marriage puzzles of his children soon after his king's defeat against the Ottomans in the Battle of Nicopolis (Никопол, 1396), which could have ended tragically for king Sigismund without help of the Count of Celje. Numerous proofs of gratitude (estates and honours) followed, all leading to the marriage between Barbara of Celje and the widowed King of Hungary Sigismund of Luxembourg in 1405. Thus, the Counts of Celje won an "ambassador" and promoter of their interests in the very top ranks as Barbara wholeheartedly supported her husband's graciousness towards his father-in-law and the Counts of Celje in general. Among other favours, Herman II, Barbara, her daughter, and Frederik II of Celje were admitted to the Order of the Dragon, and the Counts of Celje became the Princes of the Holy Roman Empire.

Barbara liked Prague and she even more loved the success she had in the city as the admired queen. She liked to talk to the folks in Czech language which was somewhat linked to the Slavic Slovenian dialects which she used back in her good old Celje headquarters. Almost no other ruling member of the nobility spoke Czech so good, often, and with pride like Barbara and her late father-in-law Karl IV did. The locals knew very well how to admire that nice Barbara's habit although she never really got used to the fact that the Czech called her Barbora instead of her preferred name Barbara which she liked so much: "Well, every Sun has its sunspots, and I will become Borbora if I must", she told the locals jokingly. She even began to drink the local beer after the pope recently allowed the breweries outside the monasteries and the Bohemian beer slowly penetrated to Bavarian headquarters.

³⁴ Štih, Peter. 1996. Celjski grofje, vprašanje njihove deželno knežje oblasti in dežele celjske. Grafenauerjev Zbornik (ed. Rajšp, Vincenc). Ljubljana: ZRC SAZU, p. 235.

Nothing was so fancy in Barbara's Prague as the incomparable clock-astrolabe which soon became her favourite destination. The oldest part of the Prague Charles University hosted Barbara's beloved Orloj, the mechanical clock-astrolabe and astronomical dial. In 1410 Vaclav (Wenceslas) IV's imperial clockmaker Mikuláš of Kadaň (Kadaně) made the famous clock on design of Jan Šindel.³⁵ Jan Šindel studied philosophy in Prague for his M.A. in arts. After his lecturing in local parish school he became the teacher of mathematics in Vienna where he also studied medicine and learned a lot from Viennese astronomers and astrologers. Vienna was not his favourite, therefore he returned to Prague as a professor of mathematics and astronomy in Prague Charles' university, the Doctor of medicine, and rector in 1410. Jan earned even more as the personal astrologer of Vaclav and Vaclav's stepbrother Barbara's husband Sigismund. Barbara soon found that Jan Šindel is far the best of all experts whom she could afford: "Sir Jan Šindel, you are the very best literati in all our Golden Prague. I have learned some twelve houses astrology back in Krakow in my times, but your knowledge is far deeper, as I'm fully aware. Please share with me some of it but be aware that I have no patience for all those boring mathematical formulas. Therefore, please let me go straight to the point where I would be able to cast my own horoscopes, if you please." Jan Šindel was respectful but at the same time he also liked to be real: "My highly respected queen my ruler of all rulers! I love your Czech spellings and I also respect the careful support you are giving to the moderate part of our Hussite movement, which is Czech in its fundament, as you well know. I must disappoint you. There is no royal way into mathematics, just as my Alexandrian model Euclid liked to tell to his royal patron Ptolemy I Soter (Πτολεμαῖος Σωτήρ). If you want to know the stuff, you must learn it with all the efforts and sweats involved, if you'll be so kind to excuse me for that strong unroyal expression. No sweet road into the mathematics, just the sweat one. On the other point, it's nice to hear that you want to cast your own horoscopes. Nice, but also frightening in the same time. I must admit that point, as I can see the consequences very clearly. That's very unfair concurrence because you will deprive of the jobs all of us, the poor astrologers. The God invented

³⁵ Jan Šindel (Jan Ondřejův, Iohannes Andreae dictus Schindel, Joannes de Prague, abt. 1370 Hradec Králové-1455/1457).

astrology to enable us astronomers to earn some extra money, because otherwise we could get hungry. And now, you are up to deprive us of that funny profitable job?" Jan Šindel drank a glass of royal wine to clean his throat because he noticed that Barbara evidently got upset: "I'm just kidding, my beloved queen. We will make the greatest astrologer and horoscope caster out of yourself because you are far the cleverest queen we ever had here in Prague. Considering the royal path into that funny mathematics, we'll invent something which will spare your time, with God's fairy help. If I've got the right idea, your nice shortcut into mathematics will fly on the wings of astrolabes and equatorium..."

Together with Barbara's networks, Jan Šindel initially supported his namesake Jan Hus, but Jan Šindel never abandoned his Roman Christian faith while he preferred science over the religious disputes. The Hussite wars forced Jan Šindel to abandon Prague for the safer Olomouc. In 1423-1437 in Nuremberg he worked as physician while he was also acting as the personal physician of Barbara's husband the emperor Sigismund after 1432. After Sigismund's death Jan Šindel became the dean of Vyšehrad Chapter (Vyšehradská kapitula) in Prague where he was in frequent touch with Barbara who lived in the nearby royal castle of Mělník. In his later years from 1445 to 1447 Jan Šindel friendly corresponded with the future pope Pius II, the humanist Enea Silvio Bartolomeo Piccolomini. Enea was the enemy of Barbara's nephew Ulrich in the times when Barbara also got alienated from Ulrich over their diverse disputes on the heritage of imperial crown. Jan Šindel used to tell Enea: "Your critique of Barbara is far too sharp. She might be from that funny Celje heritage of mixed Bosnian Germans, but her personality is far better than those of her relatives. It is true that she uses her sex-appeal to achieve her political goals, but she also used her charms to advance sciences which is not bad at all. She is not a whore, far from that, she just loves to play with the masculine hearts while she keeps her lovers on distance from her bed, at least in most occasions. The sciences she promotes are certainly not the best of them all because she prefers the prophecies of astrology and the alchemy of new materials, but at least she is up to some mathematical kind of knowledge. Therefore, she

needs to be distinguished from most of the other crowned heads whose owners never read anything except the political pamphlets. Be so kind, dear Enea, and try to reformulate your critiques of Barbara into some jokes and funny stories. I have heard that you had the unsuccessful love affair with Barbara, but that's the destiny of all us men whom Barbara turns around her fingers with her soft promising voice all the time. Forget that, that's a kind of hobby of Barbara and please try to see the funny side of it. She's great and you must admit it, sooner or later." An important Viennese humanist Piccolomini, the later Pope Pius II, convinced the future generations that the magnates of Celje relationships to humanism was relatively dull, at least if the people believe Piccolomini's memories written from the political party opposed to Ulrich of Celje. Jan Šindel tried to be the peace messenger between Barbara and Piccolomini all the time, because Jan Šindel had wide interest in the networks of the both parties in seemingly eternal quarrels. In his younger times, Piccolomini even visited the court of Celje, but he did not create excessively high opinion about the folks there who were certainly also his political antagonists. Shortly after the year 1442 Piccolomini came to the Viennese court of Frederik III where he was crowned as the poet laureate under the auspices of the emperor's chancellor Kaspar Schlick. In 1445, the emperor sent Piccolomini to Rome, while in 1447 Piccolomini became the Bishop of Trieste. In that times his sharp words against Barbara already softened a little bit because of Jan Šindel's frequent suggestions. Still, Piccolomini never stopped his sarcastic comments of Barbara and emperor's repeated splits. Enea Silvio Piccolomini used to be the worst Barbara's critic also because his voice was heard very far despite of its deeply rooted political colors. Piccolomini was certainly a top humanist and then he also became a pope. As a youngster, Piccolomini did not hesitate to pick up a girl or two of them, and he even did not try to hide those facts from the posteriorly readers in his memories. In his best days, Enea Silvio Piccolomini even tried to court the dozen years older Barbara but he was not encouraged at all which damaged his pride a lot and made him a lifelong opponent of Celje house whose peril he finally witnessed several months before he got the tiara.

Jan Šindel was aware of most of the affairs of his friend Enea, but Jan Šindel still tried to shut up or at least calm down Enea's critiques of Barbara which Jan Šindel considered to be inappropriate and harmful for the advancements of the humanistic sciences worldwide. Jan Šindel's astronomical tables were good enough even for Tycho Brahe two centuries later. Two centuries are a great space of time, which proved that Jan used to be a great observer. Despite of Jan Šindel's warnings, Barbara wanted to pave her own royal path into astronomy-astrology anyway and the astrolabe was her tool to avoid the boring difficult geometrical calculations. She wished to learn how to get at least the approximate positions of the stars with her astrolabe which became her daily companion in its golden execution of the very best Prague goldsmiths. The design of the astrolabe in use was a clear status symbol of those days, therefore Barbara got the best of the best of it.

Besides the stars, Barbara additionally also needed to find out the positions of planets while the Sun and the Moon figured as something special in both networks. While the astrolabe covered the daily needs for the approximative position of the stars, she also needed an instrument to show her the yearly approximative positions of planets, which was based on far more sophisticated geometrical theories and did not really figure as the status symbol because the most of folks found it to hard and complicated to use. The instrument used to show to Barbara the approximative positions of planets over years was certainly much more complicate than her astrolabe. Barbara's astrolabe was the best appreciated within a single day while the information which astrolabe provided repeated after one year. Barbara's instrument which show her the approximative positions of planets over years was called with its Latin name equatorium in contrast to the Ancient Greek-based name of the astrolabe. The Latin was used because the equatoria gained their popularity much after astrolabes. The Latin name equatorium meant something like a correction because of the bettering that she needed to make to convert a planet's mean position to its actual position. On Barbara's demand Jan Šindel developed sophisticated equatorium called albion which not only predicted the positions of planets, Sun and Moon, but also estimated their mutual eclipses.

Barbara demanded: "Dear Jan Šindel, you might be right in your Euclidian statement that there is no royal way into mathematics, but we could invent the queens' path into it anyway. My nice planetarium is one of the components of that path designed by the secret Byzantine Antikythera mechanism and somewhat bettered with the new contemporary ideas of Campanus of Novara.³⁶ As you know very well, I'm also in the possession of the excellent astrolabe which I'm very proud of. The astrolabe is not enough for me even if I have the possession of the best of them worldwide because my instrument is based on the Al-Andalus work of the Moorish al-Zarqālī.³⁷ My astrolabe gives me the very good approximations of the motions of stars, but I also need to know my astrological relations to the planets. Therefore, I need the equatorium, precisely the English abbot Richard of Wallingford's (1292–1336) form of it nicknamed albion which not only predicts the positions of planets, Sun, and Moon, but also predicts their mutual eclipses. I need the predictions of eclipses very urgently because I want to astonish the folks by telling them all about the eclipses they could expect in future. Not just the eclipses of Sun and very usable eclipses of Moon while the blockings of Moon are frequent enough to earn me the admiration of folks worldwide. I also need the accurate predictions of the eclipses of planets which will provide the good opinions about my knowhow among learned literati. Therefore, be so kind sir Jan Šindel and provide the nice albion for me as soon as possible." Jan Šindel was honoured with that royal demand, but he was also somewhat worried in the same times: "My dear noble queen, that will be the honour for me. I'm good and I learned a lot in my times, but the albion is clearly an extremely sophisticated instrument for me to manufacture it, as well as for you to use it. I know, you are the most clever of all queens of the world and you will be able to learn how to use my abion in no time. There is the other problem which I certainly must report to you. Me alone, I'm still not good enough to make the best of all abions which is the one you need. Please allow me to form the team of designers for that royal task. I will like to share my ideas with in the collaboration with the Viennese

³⁶ Campanus of Novara (1220-1296).

³⁷ Abū Ishāq Ibrāhīm ibn Yaḥyā al-Naqqāsh al-Zarqālluh, Al-Zarkali, Ibn Zarqala, Arzachel, or Arsechieles (1029-1087).

professor astronomer Johannes z Gmunden³⁸ who is now a kind of Viennese replacement of Sorbonne educated Heinrich von Langenstein.³⁹ As you certainly heard of, Heinrich von Langenstein began to lecture on theology and astronomy in Viennese university in 1384, soon after it was established in 1365 and I had learned a lot from him there. As you know very well, Heinrich von Langenstein was instrumental in development of astronomical tower of Viennese university where he served as the University rector in 1393/94 in the times when I was also lecturing in Vienna. Gmunden was his best student although Gmunden got his masters after Heinrich von Langenstein's death in 1406 and substantially immediately became the very first Viennese professional lecturer of mathematic, physics, and astronomical sciences in German speaking areas⁴⁰ in the times when I already left for Prague. Me and Gmunden now work in different universities and in different cities. He is more like a German, and I'm more like a Czech. But the science knows no national borders of such kinds, so we kept ourselves in friendly mutual relations. That's why I will be very glad if I could employ Gmunden as I need his help to design the very best abion for you." Barbara smiled with her best deeply promising royal smiles: "It's up to you, my dear Jan Šindel. I'm the queen Barbara and I assure you that I like them both, Gmunden and Langenstein, although I'm not as frequent guest or visitor in Vienna as I would like to be. I was there much more often before my unhappy quarrels with my own daughter and my Habsburg son-in-law, as you certainly had heard about."

Jan Šindel was glad and he immediately put himself into sophisticated networks to fulfil the queen's demands. Despite of Barbara's recent reservations because of her sad family quarrels, her Celje relatives were traditionally very generous to the Viennese literati especially after they bought the expensive building in the prestigious part of Vienna. Gmunden's work was soon advanced in the hands of Georg von Peurbach who was promoted in Vienna

after Gmunden's death. Peurbach studied in Vienna before he journeyed to Italy to meet Bianchini and Nicholas of Cusa. Soon after Barbara's death no later than 1453 Peurbach came back to Vienna. In the following year Peurbach became the court astronomer of Hungarian king Ladislaus V Posthumous, whom Barbara's nephew Ulrich of Celje supported with wealthy hands. Thus, the Celje magnates also greatly supported Peurbach and the Viennese astronomy-astrology as the network of literati. Despite of Ulrich's generosity and the wide astrological-alchemical interests of the empress Barbara, the magnates of Celje relationships to humanism was relatively shallow because Herman and Ulrich just used the humanism for his political goals and not vice versa. Many professional humanists found their views somewhat frustrating. But that is the reality: only rare rulers really love wisdom more than power like Ulugh Beg who was two years Barbara's younger eastern ruler or later emperor Rudolf II. Both lost their power to their closest relatives who knew better all the dangers around the position of vulnerable king philosopher.

3.2.1.4 Barbara's Worldwide Networks

The only real convinced humanist among the Celje magnates and maybe even among all the crowned heads of her times was Barbara. The golden Prague was the pearl of them all, but Barbara also figured as the Hungarian-Croatian queen and had to spend the considerable portion of her times in those Hungarian-Croatian headquarters which were suffering more and more under the Turkish threats and frequent raids of the Muslim or pretended Muslims from the nearby southern areas. The Hungarians tried to form some university level studies in Hungary proper or in Bratislava, but the fear of the Muslims' raids made all those projects somewhat short-lived until about twelve decades after Barbara's death. Compared to Krakow, Vienna, or Prague full of the traveling humanistic literati like Piccolomini, Barbara's Hungarian-Croatian erudite circle was far less advanced. Her courtiers were even surpassed by the later astrological reigning court of the brother of the murderer of Barbara's nephew, Matthias Hunjady Corvinus.⁴¹ Just the young Hungarian-Croatian generations were slightly better

³⁸ Johannes z Gmunden (1380/83 Gmunden in Upper Austria – 1442).

³⁹ Heinrich von Langenstein (Heinrich Heinbuche, Heinrich von Hessen der Ältere, 1325 Langenstein by Marburg in Hessen-1397 Vienna).

⁴⁰ Csendes, Opll, 2001, 305, 317, 343, 379; Donnini, 2004, 199.

⁴¹ Matthias Hunjady Corvinus (Hunyady, Korvin, 1443-1490).

with the Barbara's decade and a half younger acquaintance John Vitéz de Zredna⁴² who studied among others in Vienna to become the prominent politically oriented archbishop, mathematician, astrologer and astronomer. For his scientific pursuits, John Vitéz de Zredna used his deep connections with Pier Paolo Vergerio the Elder⁴³ whom he met in the court of Barbara's husband together with Veronika Deseniška. John Vitéz de Zredna became the tutor of the future Hungarian king Matthias Hunjady Corvinus whose brother Ladislaus Hunyadi (László) killed Barbara's nephew Ulrich in Beograd. The astrologer and physician of John Vitéz de Zredna and of the king Matthias Hunjady Corvinus used to be Regiomontanus' collaborator Polish canon Martin Ilkuš-Olkusz.⁴⁴ Martin Ilkuš-Olkusz manufactured the instruments for the Krakow university and after Barbara's death he lectured on astrology in Bratislava based short-lived *Universitas Istropolitana* as the colleague of Regiomontanus, Vitéz, and Galeotto Marzio.⁴⁵

The newly popular astrology as the mathematical part of astronomy was a segment of the spread of humanist tendencies of Francesco Petrarca,⁴⁶ and his friend-correspondent Giovanni Boccaccio's *Il Decamerone* written in 1349-1353. Both of those were Barbara's favourite writers although she had some trouble with their Italian language which was not her best and no translations were at hand quickly enough.

Arnold de Villa Nova⁴⁷ published his *Nova opera medica et chirurgica* which pleased Barbara a lot. There was a lot of alchemy there which she deeply wanted to master. Still, Barbara remained the fan of Franciscans and their medical alchemy including her favorite experimental-technological-philosophical basis of the South Italian Franciscan Paul of Taranto of Apulia alias pseudo-Geber. Paul wrote incognito his Aristotelian alchemy almost a century before

Barbara's birth, but Paul's deep insights into the alchemical *Ars magna* secrets made his works readable for many generations to come. The Krakow education of the Franciscan order of Poor Clares (Order of Saint Clare) finally brought fruits in Barbara's mind because the Saint Clare nuns proved to be her straightforward connection with Franciscan alchemy. The Franciscan William Ockham's⁴⁸ *Quaestiones*⁴⁹ were among Barbara's bests although Barbara as the fulltime mystic did not always follow the limits of Ockham's razor. William Ockham has taught in Oxford and London, the places Barbara never visited in person. His new logic was separated from the ancient Aristotle while his understandings connected the time and the movement.⁵⁰



Figure 3-1: Barbara's Samobor castle.

Barbara loved to play the Goddess in her mystic alchemic-astrological ways which brought her very close to Al-Biṭrūjī-Alpetragius.⁵¹ Barbara fully approved Al-Biṭrūjī-Alpetragius' statement that people can solve supernatural questions, which was at odds with the opinion of Aristotle, Averroes, and other scholars, although Al-Biṭrūjī was a member of

⁴² John Vitéz de Zredna (Zrednai Vitéz János, Ivan Vitez od Sredne, c. 1408 Sredna by Križevci – 8 August 1472).

⁴³ Pier Paolo Vergerio the Elder (23 July 1370 Koper – 1444/45).

⁴⁴ Martin Ilkuš (Marcin Bylica, Martin Bylica, Marcin z Olkusza, 1433 Olkusz (Ilkuš, Ilkuš) – 1493 Buda),

⁴⁵ Galeotto Marzio (1427-1497).

⁴⁶ Francesco Petrarca (Petrarch, 1304-1374).

⁴⁷ Arnaldi de Villa Nova (Arnaldus * around 1235 near Valencia; † 1311 in the sea between Naples and Genoa).

⁴⁸ William Ockham's (* 1285; † 1347/9 (Mlinarič, 1995, 869)).

⁴⁹ Under number 221 of Glonar's catalogue of the monastery of Stična books (J.Glonar, *Iz stare stiške knjižnice*. In: *Glasnik Muzejskega Društva za Slovenijo* (1937), 125).

⁵⁰ Donnini, 2004, 124.

⁵¹ Al-Biṭrūjī-Alpetragius (Nur al-Din ibn Ishaq Al-Biṭrūjī, * Morocco; † around 1204 Sevilla (J. Ziegler et all, *In C. Plinii De naturali historia librum secundum commentarius*, Basileae 1531, 29, 32-35)).

the Spanish school of Aristotle's fans.⁵² Barbara certainly felt as the queen of all queens. She was sure that she could solve supernatural questions. Her way into astronomy was certainly a kind of different from Al-Biṭrūjī's because the study of astronomy took Al-Biṭrūjī by surprise after he saw some antagonism between Aristotle and Ptolemaic teachings. Al-Biṭrūjī asked himself why Ptolemaic teachings objected to Aristotle's philosophical attempts, although Al-Biṭrūjī essentially took all the parameters of the *Almagest*.⁵³ Of course, Al-Biṭrūjī quoted the Quran (Koran) to support his ideas. The clever Al-Biṭrūjī was aware that all those astronomical novelties were not at Muhammad's disposal when he dictated his Quran (Koran). The Quran (Koran) does not mention the eccentric spheres, but Al-Biṭrūjī felt rightfully that they cannot be ignored. Based on the Quran Al-Biṭrūjī rejected all spheres except seven of them. He equipped his manuscript with illustrative drawings, but they were not too close to the later N. Frischlin's pictures.⁵⁴ Copernicus mentioned Al-Biṭrūjī's work on the order of the planets, but Regiomontanus refused Al-Biṭrūjī because of the supposed Al-Biṭrūjī's erroneous interpretations. Al-Biṭrūjī took over the computations of Levi ben Gerson († 1344) and other Jewish astronomers. Al-Biṭrūjī and his fellow Moorish genius al-Zarqālī were among five Muslims whom Copernicus quoted⁵⁵ after Barbara's death, which was also a kind of consequence of Barbara's promotions of Al-Biṭrūjī's merits.

As the reigning queen, Barbara was not a great fan of Roger Bacon's anarchistic in-jailed worldviews of the marvelous poverty needed for the sound scholarship, but she liked Bacon's practical astrology needed for the contemporary judicial predictions. In fact, that was the same kind of astrology which Barbara practiced. Roger Bacon's praised optics as a new academic discipline to be introduced in curricula on behalf of his informal teacher Robert Grosseteste of Franciscan Oxford school. Roger Bacon's promotion of optics as the new research field was the very first one in the row

⁵² N.D.I. Al-Biṭrūjī, B.R. Goldstein, *On the Principles of Astronomy*, New Haven/London 1971, ix.

⁵³ Al-Biṭrūjī, Goldstein, *ibidem*, 3, 7, 19, 75.

⁵⁴ Al-Biṭrūjī, Goldstein, *ibidem*, 21.

⁵⁵ J. Ragep, Copernicus and His Islamic Predecessors, In: *Hist.Sci.* (2007), 65.



Figure 3-2: Barbara's Samobor castle from inside: what was left of her lab?

which later promoted magnetism, electricity, heat phenomena, chemistry, and so on. Barbara with whole heart supported the claims like that, while her support was in some senses much more important than the opinions of the professional literati because Barbara was their wealthy patron as well as the renowned practitioner of the alchemy-astrology focused on new materials. Barbara was not interested just in the experimental part of Bacon's optics, but she wished to learn more about the nature of light for her transmutations of metals where the colors of the changeable products played the prominent role. Barbara's favorite therefore became the Franciscan Thomas of York with his studies of the nature of light.⁵⁶ In her practical astronomical-astrological pursuits Barbara needed optics, but the somewhat occult forces of magnetism were even more important to her. Roger Bacon's teacher and friend was his fellow French Franciscan Pietro di Maricourt⁵⁷ who announced the *Epistula de magnete* of eternal impact in 1269.⁵⁸ Barbara liked the stuff and used huge magnets in her Samobor alchemic lab in tight connection with enterprises in her nearby mines of copper. Her unconventional behavior earned her a dangerous funny title of black queen, probably connected with her widow's black suits or with her alchemical dark arts. The vampire legends of her black witchcraft whereabouts never ceased to

⁵⁶ Thomas of York (OFM; † 1268/69 (Donnini, 2004, 141)).

⁵⁷ Pietro di Maricourt (Petrus Peregrinus, * around 1220).

⁵⁸ Donnini, 2004, 129.

be told in Samobor, nearby castle of Medvedgrad, and the nearest city of Zagreb.⁵⁹

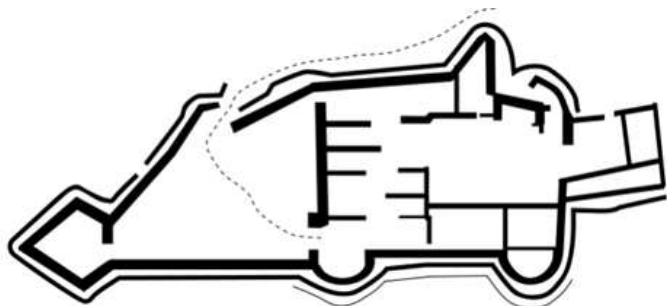

Figure 3-3: The layout of Barbara's Samobor castle with the lab in the cellar.

Barbara's fascination was the motion which she observed in her touchable *Ars magna* transmutations as well as in the remote motions of the heavenly bodies. Her inspirations were again the Franciscans, among them Richard of Mediavilla.⁶⁰ In his theory published in *Calculatores* he set the new perspective of physics. Richard of Mediavilla argued against the fundamental principles of Aristotle's physics-metaphysics.⁶¹ The English Franciscan of Augustinian orientation Roger Marston⁶² was a Parisian student of the Franciscan optician John Peckham (1230-1292) who died as the Archbishop of Canterbury. In 1328 the later Archbishop of Canterbury secular priest of Oxford Merton college Thomas Bradwardine (c. 1300-1349) wrote his *Tractatus proportionum, seu de proportionibus velocitatum in motibus* where he studied the relationship between resistance and speed. He rejected Aristotle with his own rate of velocity as the ratio of an exponential increase of the driving force to resistance as the first Western author to introduce the exponential growth in the equation of physics. Bradwardine's velocities vary arithmetically, while the ratios of force to resistance vary geometrically. Bradwardine's theory of isoperimetric figures

(having equal perimeters) was widely used.⁶³ The Englishman Gualterius Burlaeus of Oxford and Parisian professorships wrote about the theory of impetus in his comments of Aristotle's physics published later in 1589.⁶⁴ Gualterius Burlaeus used the arguments of logic in the newly advanced fields of physics. He was among the first who focused Barbara alchemistic interests on the newly bettered theory of heat. Gualterius Burlaeus used logical argument to promote the idea of the singular substance of heat in contrast to the opposite idea of the separate substances used to describe the coldness and the warmness. Gualterius Burlaeus claimed that contrary forms, such as hot and cold, belong to the same ultimate species because logically things equidistant from an extreme are of the same species. By Aristotle Gualterius Burlaeus argued that if a cooled body is immediately reheated, at some instant, *B*, preceding the first instant when the body is cold, *A*, it will have a degree of heat, and at some instant, *C*, succeeding *A*, it will have a degree of cold, both of which degrees will be formally equidistant from maximum heat and thus of the same species. This argument also reflects contemporary debates over the latitude of forms, the intensive range of possible degrees that a quality may possess. It also reflects the first and last instants of change. Gualterius Burlaeus might have been Ockham's classmate and the student of John Duns Scotus in Oxford as a part of the once huge British Franciscan scientific networks which Barbara admired so much. As a lecturer in Paris Gualterius Burlaeus quarreled with the Oxford lecturer Ockham over their different forms of peripatetic physics.

Barbara was equally interested in North Italian contributions to the knowledge which suited her. As the reigning queen and the wife of the emperor, she certainly supported the fans of her husband called Ghibellines in Apennine Peninsula. The employee of Emperor's fans Ghibellines Guido Bonatti⁶⁵ first studied law, until he was converted with the mathematical muse. He became a professor of mathematics at the University of Bologna, occasionally even in Paris. Bonatti became one of the leading astrologers and astronomers of his time,

⁵⁹ Paušek-Baždar 2008. Königin Barbara zu Cilli als Alchimistin in Samobor. *Godišnjak Njemačke narodnostne zajednice* 15/1: 275, 279; Žvab, Andraž, 2016. Baroque Alchemy in Carniola. *Kronika*. 2: 199–224; Katanec, Sara. 2014. *The Perquisite of a Medieval Wedding: Barbara of Cilli's Acquisition of Wealth, Power, and Lands*. MA thesis, Budapest, 9, 10.

⁶⁰ Richard of Mediavilla (* around 1249; † about 1307).

⁶¹ Donnini, 2004, 131.

⁶² Roger Marston (* around 1235; † about 1303).

⁶³ Donnini, 2004, 139, 140.

⁶⁴ Gualterius Burlaeus (Walter Burley, * around 1274; OFM; † about 1345 (Donnini, 2004, 142)).

⁶⁵ Guido Bonatti (1210-1296).

he was perhaps even the most important astrologer of 13th century.⁶⁶ He correctly predicted a victory of the Ghibellines' army of Siena. Federico Guido Novello helped the defeat of the Florentine Guelphs in the Battle of Montaperti in 1260, after the victorious Ghibellines occupied the city. Barbara supposed that they maybe won precisely because the Bonatti's prophecy uplifted their extra courage, as Bonatti himself opposed Guelphs and the Pope, which was certainly also the option of Barbara's husband, the emperor. At the court of Emperor Frederik II Bonatti collaborated with the polyglot famous for his Arabic-Hebrew-Greek knowledge named Michael Scotus,⁶⁷ even if Bonatti did not quote Scotus' adaptation of Johannes de Sacrobosco's⁶⁸ *Tractatus de Sphaera*. Bonatti's reputation grew after his success in providing a proper prophecy for the count Guido de Montferrato (Montefeltro) whom Pope Martin IV together with French allies besieged in the city of Forli. On 1 May 1282 Montferrato escaped and won the unequal battle despite numerous wounds. Bonatti derived his knowhow from the Arabic knowledge and added his own experiences. He was the first to explain the importance of astrology. He carefully considered the positions of planets, their impact on the Earth, conjunctions, and the like.⁶⁹ Bonatti died in a Franciscan monastery. Despite the long-standing conflicts with Franciscan, as an old man he dressed himself in a Franciscan habit which pleased Barbara a lot.

The other Barbara's window towards the eastern wisdom was Pietro D'Abano⁷⁰ who had embarked on a longer visit to Constantinople (Istanbul) where he read the works of Galen, Averroes, and Avicenna in original. After returning home he acquired a reputation as a translator. He has taught medicine, philosophy and astrology at the University of Paris, and since 1306 in Padua as the main supporter of Aristotle and a friend a few years elder Marco Polo.⁷¹ Both won Barbara's sympathies although

both spent their times in prisons and D'Abano even died there as the captive of Inquisition because of his magic.

The North-Italian Humanists' frames were soon upgraded from eastern sources which Barbara preferred because of her Bosnian networks of Barbara's Celje grandmother Katarina Kotromanović and Bogomil's networks related to Hus which Barbara's husband sadly destroyed during his bloody crusade.⁷² Katarina Kotromanović was the first cousin of Bosnian-Serbian king Tvrtko I Kotromanović who was closely related to the legendary prince-king Marko (Mrnjačević). Despite of turbulent times of wars they used to have the first-hand knowledges of Byzantine and Muslim sciences which expanded mostly through land routes of those times. Barbara was interested in philosophical aspects of the alchemistic research in India, and she was as well extremely upset with the very first supposed perpetuum mobile. The device was constructed in India by Bhaskara II⁷³ for more religious aspects, while the Arabic traders transferred that wonder to Barbara's nearby European headquarters as the very first of its kind. In Europe, Bhaskara's tool lost its religious-philosophical meaning which was essential for its whereabouts in India. The Christians with Barbara included had no way to understand the Indic religious philosophy, therefore they just employed the technical aspect of the imported item, as they did with so many other knowhows which they imported from India including the infinitesimal calculus. The great figure of Barbara's contemporary new eastern knowhows was Madhava⁷⁴ with his major work of 1403 in Sanskrit based on his Indian predecessors of Kerala school. Madhava was not that much interested in gnomons, while he preferred the mathematical part of astronomy called astrology with the disputed rotation of planets included. He bettered the calculation of the number pi, the series expansions, as well as the integrals. Those mathematical details were not the ones which Barbara liked and understood the best, but she certainly enjoyed each part of Indian patina in her astrological predictions.

⁶⁶ L.Thorndike, 1923, 2: 826; J.A.Hill, E.B.Heffelfinger, *Scientific, Medical & Natural History Books*, New York 1983, 11.

⁶⁷ Michael Scotus (1175-1232).

⁶⁸ Johannes de Sacrobosco (c. 1195-c. 1256).

⁶⁹ L.Thorndike, 1923, 2: 830-833.

⁷⁰ Pietro D'Abano (1257-1316).

⁷¹ Marco Polo (1254-1324 (Donnini, 2004, 204)).

⁷² Rakovec-Felser Zlatka. 2013. *Na valovih sreče in pogube*.

Kraljica Barbara Celjska. Maribor; Pivec, page 36-37.

⁷³ Bhaskara II (1114-1185).

⁷⁴ Madhava (1340 Sangamagrama-1425).

Further east, the orphaned kid of Muslim origin was captured by Chinese-Han Ming rulers after his father was killed. Under his eunuch name Zheng He,⁷⁵ the orphan led the prolonged expeditions to South Seas and Americas. Most important of those Easterners was Barbara's peer, the grandson of Timur (Tamerlane) called the sultan Ulugh Beg.⁷⁶ After his lost Nicopolis battle Barbara's husband and father considered Tamerlane as a kind of ally since Tamerlane had stopped the Ottomans for a while after Tamerlane defeated and captured Bayezid I in Ankara (Angora) in 1402. Therefore, the Catholic Europeans also supported Tamerlane's grandson and student Ulugh Beg, but Ulugh Beg proved to be entirely casted from the different kind of mould as a kind of Plato's philosopher-ruler, actually the best of that kind which ever existed although Barbara resembled Ulugh Beg in her somewhat narrower networks. Barbara never had a real observatory of her own, although she always wished to erect it. Ulugh Beg established his observatory in Samarkand with his excellent employees including al-Kāshī⁷⁷ and Ulugh Beg's student reformer of Aristotelian astronomy-mechanics al-Qushji.⁷⁸ The enterprise worked nice like a kind of heavenly clock, but those heavenly knowhow were never designed to work in the frames of the naughty evil greedy humans. The great Ulugh Beg's observatory worked just until Ulugh Beg's own son found the earth more promising compared to his murdered father's stars a year and half before Barbara's own death.

Barbara and her networks of humanists Platonists soon rediscovered their Balkan-Byzantium headquarters with the distant Ulugh Beg included as soon as the Byzantines began to migrate westwards from their collapsing Greek-speaking traps threatened by the Turkish Ottoman Muslims. Many of those eastern refugees joined Barbara courts long before the most famous of those Byzantine lecturers from Constantinople named Johann Agyropolus⁷⁹ fled to Italy to teach Leonardo da Vinci and the Medici about Vitruvius' art. As all his erudite Byzantine fellows, Agyropolus knew the ancient Greek

language which enabled him to translate a lot of Aristotle's Physics inter alia. Agyropolus got his additional doctorate in Padua during a diplomatic mission, lectured in Padua until 1471, in Florence and then in Rome. Barbara liked the golden colors of the Byzantine whereabouts and tried to get as many Byzantine refugees in her court as possible to learn more about their alchemy.

3.2.1.5 Principal-Counts of Celje, not to Speak about their Veronica of Desenić

Barbara liked to use her royal status to advance the Counts of Celje. With Sigismund, she founded the Order of the Dragon⁸⁰ just before Christmas on 13 December 1408. The funny order brought together the closest imperial confidants and the biggest, wealthiest, and the most important European rulers of the time. Barbara and her daughter were the only females of that famous elite order, whose members included Herman II and Frederik II of Celje. Barbara was proud: "That Order of the Dragon of ours is the real achievement! Very good indeed also because it seems that I'm the only real woman in charge there besides my lovely daughter Elizabeth."⁸¹ Never mind the feminism, but that membership of mine makes me more than equal of all the men involved including my husband, father, brother Fredrik, and brother-in-law Nikolaj II Gorjanski (Garai). My grandmother's relative the Serbian despot poet Stefan Lazarević or the would-be Transylvanian ruler are somewhat obsolete founding members of our order, but there is still something great in that funny Order of the Dragon of ours. The insignia of the Holy Grail are there and everything I need for my astrological-alchemical work."

In 1411 Barbara of Celje's fiancée Sigismund was elected as the king of Romans (*Romanorum Regina, Römisch-deutscher König*), as the ruler in-waiting of the Holy Roman Empire of German nation, and he was crowned King of German nation in Aachen on 8 November 1414. He exercised the right to have his wife crowned alongside him, and Barbara of Celje thus became Queen of Romans (*Römisch-deutscher*

⁷⁵ Zheng He (鄭和, 1371-1433/35).

⁷⁶ Ulugh Beg (1393-1449).

⁷⁷ Ghiyāth al-Dīn Jamshīd Mas'ūd al-Kāshī (al-Kāshānī, 1380-1429).

⁷⁸ Ala al-Dīn Ali ibn Muhammed al-Qushji (1403-1474).

⁷⁹ Johann Agyropolus (1415-1489).

⁸⁰ Order of the Dragon (German: Drachenorden, Latin: Societatis draconistarum).

⁸¹

http://www.bibliotecapleyades.net/sociopolitica/esp_sociopol_dragoncourt07.htm

Königin), which legitimately placed her at the very summit of her contemporary state authorities. The Germany of those times had not much in common with German national or linguistic boundaries because it also included Denmark as well as North Italy, Croatian Istria, Carniola, Styria, Bohemia, and other Roman or Slavic lands.



Figure 3-4: Barbara in Constance as noted by Ulrich of Richenthal

The coronation to the Queen of Romans (*Römisch-deutscher Königin*) in Aachen (1414) and Barbara's glorious accompanying of her husband to the Council of Constance (1415) which was not Jan Hus' favourite were the highlights of Barbara's marriage to Sigismund. The king Sigismund soon became somewhat upset: "My dear Barbara, you have no right to cry over the destiny of that crazy prophet Jan Hus. The prophets are only good for ordinary folks, but we are the rulers and we do not mess with those ugly smelling folks. You are going much too far with the astrology and alchemy of your beautiful face." The king's warnings were in vain because Barbara was just too much extravagant for her time and place. It was never quite certain what Barbara did in Constance (Konstanz). The chronicler Constance native Ulrich of Richenthal⁸² mentioned

her only rudimentarily, because Barbara did not participate in the Council. Church matters were a kind of menaced men's affairs, and like the other queens who came to Konstanz during the Council, Sigismund's Barbara was not allowed to attend the meetings. But Barbara had her own ways to promote herself.

The rumors about Barbara's crazy alchemistic-astrological ways soon proved to be much to harmful for her husband's networks. Their honeymoons were accelerated into strange orbits followed by their break-up because of Barbara's destructive midnight shouting and Constance escapades. Very quickly there was their royal couple's first (informal) separation in 1419 while Hus's fans led by former chamberlain of Barbara's friend Sophia of Bavaria named Jan Žižka⁸³ fought down Barbara's poor husband in every battle of theirs. Žižka promoted the use of gunpowder and his newly invented movable field artillery which soon made the Bohemians prominent in artillery business until the industrialization of that field in Napoleonic wars. Barbara's model the Franciscan Roger Bacon was among the first to promote gunpowder in Europe, but Barbara certainly disliked Žižka's making any profit of that discovery. Barbara commented to her furious royal husband: "My favourite Chinese alchemist Wei Boyang⁸⁴ described the substances needed to produce the gunpowder mixtures long ago. He was the descendant of a long tradition of Chinese magicians-chemists while he composed the earliest book on alchemy and the first document on chemical composition of gunpowder worldwide nearly thirteen centuries ago. You are stupid my dear husband, it was not clever to let that one-eyed Žižka of Cyclops' sort to be the first to use such an old invention in Christian European lands. If you ever bother to listen to your wife's alchemistic advices, you could have been much earlier user of gunpowder provided in my alchemy labs." But the facts went beyond Barbara's possible interferences: the combative Czechs Taborites of Žižka's camp were a kind of peoples' army like the French revolutionaries four centuries later and no crowned head was their match.

⁸³ Jan Žižka z Trocnova a Kalicha (Johann Ziska, John Zizka of Trocnov and the Chalice, c. 1360–1424).

⁸⁴ Wei Boyang (Wei Po Yang, 魏伯陽).

⁸² Ulrich of Richenthal (died about 1438).



Figure 3-5: Barbara during the Constance Council as noted in the chronicle of Ulrich of Richenthal.

The split of the royal couple was short-lived because Barbara was just too clever to be left behind and the king certainly needed her charm, as well as her alchemy and astrology. Barbara of Celje was an important representative of the Counts of Celje in the highest circles of European nobility. Barbara used to tell her husband: “Well, honey, it really seems that you dislike my midnight hysterical shouting, which I deeply regret. The shouting is not all I know. My connections with Krakow Polish court of my beloved sister Anna are deep and therefore please employ me into your diplomatic service. I will become more than useful there, you can bet on that.” Sigismund looked at her eyes after another night during which he was unable to get any sleep at all and at the first sight wished to call Barbara names because of all that night suffering she has provided for him. He just began to shout, but he suddenly realized that Barbara might have a right point, at least in that diplomatic whereabouts. Soon Barbara played a major role in establishing peace between the Polish crown and the Teutonic Knights, and in the alliance between the Grand Duchy of Lithuania and the kingdoms of Poland and Hungary because the Polish kingdom was the biggest European country of those turbulent times.

Barbara of Celje was one of the most progressive and free-thinking women of the age. She was a genial diplomat; she knew how to make money, spoke several languages, and argued in favour of new artistic and social developments. Most of all she had a strong interest in astrology and alchemy. She was often depicted negatively during her life and later by jealous historians, but more recent studies are presenting a more objective image of her.

Barbara was the secret shadow behind the disgusting legend about her unwanted sister-in-law Veronika Deseniška. She tried to learn some Veronika’s alchemistic secrets, but Barbara didn’t have the guts to oppose her father Herman’s will. Barbara was also very instrumental to smoot her father’s seizure of Ortenburg’s heritage. Ulrich duke of Teck⁸⁵ was the brother of Margaret Teck.⁸⁶ Their parents were Frederik IV Duke of Teck⁸⁷ and the countess Anna. Margaret Teck, the wife of Otto’s son Frederik III of Ortenburg⁸⁸ helped a lot to advance Barbara’s networks. Margaret Teck’s only son died young and her marriage with Frederik of Ortenburg proved to be the unhappy.⁸⁹ On April 28, 1418 in Leibnitz⁹⁰ a nice lady Margaret Teck, the relative of Anna’s stepfather Ulrich of Teck, gave the other half of poisoned apple to her unsuspecting husband Frederik III who became the very last Count Ortenburg a moment later. After that sad family quarrel Margaret’s relatives, the mighty Counts of Celje, took over Gottscheerland and other former Ortenburg property in 1420. Barbara’s father count Herman II of Celje, the son of Herman I,⁹¹ inherited the Ortenburg areas with Gottscheerland included by their mutual contract of 1377 and sly counts of Celje kept the property until their abrupt princely end in 1456. Margaret’s other unlucky brother was the patriarch of Aquileia Ludwig II/IV duke of Teck who lost his Aquileia lands to the Venetians and resettled to Herman’s Celje court, which was a great blow to her pride. But she was strong and powerful,

⁸⁵ Ulrich duke of Teck died in 1432.

⁸⁶ Margaret Teck married Ortenburg († 1422).

⁸⁷ Frederik IV Duke of Teck’s father was Frederik III of Teck (1325-1390), the eldest son of Ludwig III of Teck.

⁸⁸ Frederik III of Ortenburg († 1418).

⁸⁹ Skubic, Anton. 1976. *Zgodovina Ribnice in Ribniške pokrajine*, Buenos Aires: Baraga S.R.L. 12, 318-319, 321-323; Weltzer und Welte. 1882. *Kirchenlexicon*. 6: 847; 7: 715.

⁹⁰ Troha, 2003, 18.

⁹¹ Herman I of Celje (1333-1385).

and she did not hesitate to offer her poisoned half of an apple to her husband to enable her Celje relatives to get his heritage. The son-in-law of Herman II of Celje became her relative the future emperor Sigismund of Luxemburg,⁹² and that was the power of all powers. Sigmund betrayed the Czech priest Jan Hus to bring a war and with it the new settlers from disturbed Bohemia to her lands all along the Upper Kolpa river basin. The Thuringians might also provide new migrants for her Upper Kolpa areas. Her dreams have come true. The land of hers was fertile and inhabited, although her husband was now buried and the former Ortenburg areas passed to her relative Herman II of Celje.⁹³

Before Barbara's birth, in 1388 Count Herman II of Celje engaged and around the year 1405 married his eldest son Frederik II († 1454) with Elizabeth Frankopan, the daughter of Stjepan I Frankopan of Modruš and of the island of Krk. Stjepan was a prince between 1360 and 1390, and he married Katarina, the daughter of Franjo Carrara, master of the Paduan Town.⁹⁴ The diligent bride Elizabeth Frankopan did not hesitate too much and quickly gave birth to Ulrich II. She brought the dowry of the prosperous Bakar town harbor to Frederik II because the Counts of Celje dreamed about their accession to the seaside. The city of Bakar became the principal harbor for the smuggling trade from the central Carniola because before the collapse of Zriny-Frankopan Conspiracy (1670) the town of Bakar was not subordinated to the regulations of Habsburg imperial customs officials. Herman II prosperously married his daughter Barbara of Celje⁹⁵ with the king Sigismund I of Luxemburg.⁹⁶ Herman became Croatian, Slavonian, and Dalmatian Ban.⁹⁷ Herman also found the suitable high positioned husbands for his daughters Elizabeth and Anna: Elizabeth got the bed of the fifteen years old teenaged count Majnard Henrik of Gorica (Gorizia, * 1385; † 1426) in the year 1400, and somewhat later Anna married the palatine Nikolaj II Gorjanski whose sister was a

second wife of the prince Nikola IV Frankopan.⁹⁸ Around the year 1445 Herman's granddaughter Margaret († 1480), the daughter of Herman III, married for the second time and her choice was Vladislav († 1463), the son of the Silesian Duke Cieszynsko-Glogovski. Herman II used to say to his family members: "Well, I've done all possible to make you a great family. Probably I cheated a little bit and ruined a person or two on that way to the top, but that's eventually the price you had to pay if you want to become a real successful ruler. Our focus of expansion is now shifting from the northwest to the southeast, from the overcrowded networks of Renaissance rulers to the Balkans. To succeed, we need the Byzantine collapse, which is at hand, but we need even more to defeat the Ottomans, which we failed to do altogether as far. With Ottomans behind our necks, all our efforts will perish into the ashes. Remember, you have to produce as much sons as possible and accomplish all military, diplomatic, astrologist, or alchemistic networks to keep those dangerous Ottomans out of Balkans."

On February 28, 1420 in Bratislava (Pressburg) the Emperor Sigmund confirmed the Ortenburg heritage to Sigmund's father-in-law Herman II of Celje, and in Celje the prolonged visitor Patriarch Ludwig gave to Henrik all former Ortenburg-Aquileian feuds including Gottscheerland.⁹⁹ In that way the Celje counts became the strongest family dynasty in the Slovenian National area and Frederik used his opportunity to accommodate his illegal nest above the settlement of Gottschee. In the year 1421 Herman II gave to his son Frederik II a part of his possessions including the manors of Teničnjak, Samobor, Mehovo, Novo Mesto, and Kostanjevica with Frederik's independent court in Gurckfeld (Krško) town on the banks of Sava river. Frederik II liked to hunt in Gottscheerland forests, and he finally hunted up his best trophy named Veronika there as the very best pearl from the royal court. From around the year 1415 he lived separately from his legal wife of the mighty Frankopan family, which

⁹² Sigismund of Luxemburg (1368-1437).

⁹³ Herman II of Celje (1365-1435).

⁹⁴ Cividini, 1935, 78-79.

⁹⁵ Barbara of Celje (* 1392 Celje; † July 11, 1451).

⁹⁶ Sigismund I of Luxemburg (* 1368; Hungarian king 1387, Emperor 1410/1417, Bohemian king 1419-1421, 1436-1437; † 1437 (Burić, 1991, 41)).

⁹⁷ Mlakar, 1996, 59.

⁹⁸ Nicholas II Garai (Nicolaus de Gara, II Garai Miklós, Nikola II Gorjanski, 1367–1433 (Lukanc, Maja. 2016. *Ana Celjska*. Celje: Pokrajinski muzej, 52)). Katanec, Sara. 2014. *The Perquisite of a Medieval Wedding: Barbara of Cilli's Acquisition of Wealth, Power, and Lands*. MA thesis, Budapest, 95.

⁹⁹ Steska, 1896, 119.

was somewhat dangerous move. In the year 1422 or a year later his Frankopan wife was found dead in her castle Krapina, but the cause of her misfortune was never clearly put at the limelight. It is quite possible that Herman II's persistent tries to bring together the unhappy married couple on bad terms caused the disaster. Herman II wanted to get as many grandsons as possible and the only reliable grandson Ulrich was not enough for him. Herman had heard about so many families which got extinct in their male lines that he became somewhat paranoiac with some astrological predictions suggesting the similar ill fate to his own family. After 1422 Frederik II was not without guilty merits when he erected the castle above Gottschee for his new fiancée Veronika von Desenice.¹⁰⁰ Frederik wanted Veronika of Desenice and Margaret Teck was happy to provide for the new couple her previous build castle of Fridrichstein above Gottschee for their love nest just before Margaret died. Their residence was called Friedrichstein ever since. The jovial widower Frederik II neglected his father and Emperor's opposition with dangerous anger included and married Veronika in the year 1424/25. Her family could originate in the castle Desinić across Sotla in Croatia near Slovenian Podčetrtek, but she is rather unknown in Croatian genealogy. She came from one of Hungarian-Croatian castles while she had some connections with Silesia. She was of noble origin, but she certainly had much lower rank compared with the counts of Celje. Right after her marriage before the summer of 1425 the circumstances sharpened so much that Frederik II asked for asylum in the republic of Venice. On June 25, 1425, Venetian doge and senate refused Frederik's petition because they quarrelled with Habsburgs just as Herman II did and did not want to abandon Herman's support. The Venetians also rejected Frederik's offer to buy his properties from Elizabeth's dowry on January 7, 1424, probably because they considered the deal dangerous as Frederik had no real practical control above those estates. Frankopans recaptured those manors, but the Emperor asked them to return them back in the year of Herman's death of 1435.¹⁰¹ In 1425 the Venetians took over the secular power of Aquileia Patriarch Ludwig II in Friuli and Istria,

therefore humiliated Ludwig asked for his relative Herman's help, resettled to Celje, and confirmed the feuds which Herman inherited from Ortenburgs. Ludwig prolonged visit in Celje stimulated the Celje landlords' appetite to develop their own bishopric in Celje, but in all real comparisons the settlement of Celje was far too small to compete with Vienna or similar metropolis.

The Emperor Sigismund hired the Danish King Erik VII who visited Hungary between June and August 1424, to give the judgment about possible Frederik's involvement in his wife's murder case. Frederik did not seem to be much upset, but next year the emperor captured Frederik and handed him over to his father-in-law, Herman. Barbara was silent: "The family quarrel is the worst of them all. I understand my brother, he wants that bitch Veronika so much after he discovered her in my court. That relation could bring Herman the necessary male offspring, just in case if my nephew Ulrich will get some troubles in that point. On the other hand, my crazy brother crossed the line. He expected that my father will calm down after Veronika gave birth to his grandson, but Herman just wasn't that sort of guy..."

Herman tied his unhappy son for his captured trip in a covered wagon. He closed his chained heir in the tower of Celje County castle Ostrovec, forced him to return his manors, and demolished the Friedrichstein Castle above Gottschee.

The unwanted daughter-in-law Veronika and her chambermaids hid in the ruined castle, in nearby woods, and in remote village Kunč (Kunschen, Kuntschen, Kleč) cave under the Gottscheer Horn forests east of Altlag. The ladies hid in nearby ice cave which was 10 m high, 10 m long and 20 mm wide. The air currents kept the ice in the cave almost all year round to enable the nice ladies' comfortable summer and autumn stay¹⁰² with the cold summer beer and wine included. After Margaret Teck passed away, Veronika had nobody to relay on, so she was hiding for a while in a cave near Kunč village east of Gottschee. A century and a half later the Kunč Village had a hide and a half. The village probable got its name from its inhabitants named Künig who

¹⁰⁰ Veronika von Desenice (Dessnitz, Dessenitz, Desnicze, Teschnitz, Teschenitz, Dessewitz, Hatschen, Kotschee).

¹⁰¹ Grafenauer, 1982, 412.

¹⁰² Thanks to dr. Miha Čekada for a note.

had the neighbours with the family name Mauser there in the year 1574.

The cave was horizontal and tall, but the ladies from her court were not extremely happy there with only dirty peasants for their company. Veronika felt like her youthful beauty is passing away in vain, so she tried to make a short visit to her domestic folks on Croatian side. The reckless Veronika secretly but not cautiously enough visited the castle of Frederik II in Petovia near her reputed home castle of Desinić. The sly Herman traced her out and closed her to Ostrovo (Ostrovec) Tower where her husband Frederik already waited for the better days. She was judged in Celje but the able lawyer saved her from the witchcraft accusations which could be the very first one in that area. Herman eventually had no legal rightful position to bring the noble Veronika to the court in Celje.¹⁰³ Veronika cried: “By murdering me you will also murder your own grandson. Your other grandson Ulrich probably doesn’t like my son, his eighteen-years younger kid stepbrother as his future competitor, but that doesn’t change the fact that you are going to ruin your own dynasty!”

Veronika’s father-in-law Herman II who did not want to be her father-in-law was quick to prove that Veronika’s beauty was really vanishing. “Hello, Veronika, the damned choice of my crazy vicious son! Please be so kind and leave my Frederik alone, there are plenty of other noble lovers you could play with,” Herman demanded. Veronica was proud: “My dear father-in-law, please just remember the times you were of Frederik age,” and she tried to charm Herman a little bit because she did not recognize that the power is the only charm Herman really loved: “I’m blind to your charms, nice maid. Please behave yourself or you’ll get drowned as you do not really know how to swim properly!” What a terrible mistake! Under her heart, Veronika was carrying Herman’s grandson or more of them who could save Herman’s dynastic male line. Herman did build the dynasty, but he also ruined it for the Habsburgian benefit. In fact, some of those high society folks did not care much for their grandchildren and did not cry when their heavily grabbed property passed to their related dynasties. The life and death were quick

¹⁰³ Štih, Peter. 1996. Celjski grofje, vprašanje njihove deželno knežje oblasti in dežele celjske. Grafenauerjev Zbornik (ed. Rajšp, Vincenc). Ljubljana: ZRC SAZU, p. 235.

close friends of their times and they did not really care for posteriors except some more clever among them like the Habsburgs or Auerspergs. Despite of Veronica’s success at the provisional unlawful court of Celje, Herman ordered two knights to drown Veronica in the bathtub on October 17, 1425, although it was a pity to get rid of such a beauty. With such a cruel act Herman excused himself of supposed guiltiness for the death of his daughter-in-law Elizabeth Frankopan in the eyes of Croatian nobility. In those times the Frankopan Prince was the only Elizabeth’s brother Nikola IV¹⁰⁴ and Nicola could be the very hard enemy if he felt that his honor was offended.

The second Herman’s son Ludwig died in the year 1417, his illegitimate son the bishop Herman died in year 1421 after the unsuccessful operation in Celje, and Herman III died in the year 1426. Solitary and full of misfortune Herman II had to release his only son Frederik before August 24, 1426 because Frederik was simply the only son Herman had left. To clear up the consequences of lengthy quarrels Frederik II went on a pilgrimage to Italy. In the same times, his and Elizabeth’s only surviving son Ulrich II¹⁰⁵ went on a Spanish pilgrimage in the Iberian Santiago de Compostela, but Ulrich eventually forgot to arrange a good looking Celje heir with his countess Katarina Branković because all his offspring died much too early.

Veronika was buried in Braslovče, but disconsolate widower Frederik later took her bones to the monastery of Carthusian monks in Jurklošter. He prayed there on the anniversaries of her death and gave a present to the monastery of Carthusian monks in Bistra for her memory.¹⁰⁶ Frederik renovated the castle Friedrichstein above the settlement of Gottschee in the year 1433, but he was not looking for a new bride,¹⁰⁷ although several beauties tried to charm that wealthy old man. After the death of Herman II, the Emperor Sigismund of Luxemburg confirmed to his brother-in-law Frederik II the former Ortenburg feuds and raised Frederik and his son Ulrich II to the rank of Principality of Holy

¹⁰⁴ Nikola IV (1393-1432 (Cividini, 1935, 79-84).

¹⁰⁵ Ulrich II (* 1406; † November 9, 1456 Belgrade).

¹⁰⁶ Grafenauer, 1982, 413.

¹⁰⁷ Mlinarič, 1982, 64, 81, 82; Valvasor, 1977, 232; Simonič, 1956, 86-87; Kordiš, 2001, 8; Jakič, 2001, 46.

Roman Empire on November 30, 1436. As Princes and Counts they were subordinated only to the Emperor himself, although the Habsburgs refused to accept all formal aspect of Celje Princes' independence and still observed Celje magnates as one of their subordinates.¹⁰⁸ There was almost no higher possible position available for Celje landlords, but the breakdown of Celje magnates happened all to soon two decades later.

3.2.1.6 Habsburg Shares

Barbara died in 1451, her brother Frederik died in 1454, and Frederik's son Ulrich was killed in 1456 as the very last male of his descent. A year after Ulrich's death the Gottscheerland and other possessions of Celje magnates passed over to Habsburgs because of the similar heritage contract (1443) which enabled Counts of Celje's heritage after Ortenburgs' huge possessions lost their last male descent three decades earlier. In December 1457, Ulrich's widow Countess Katarina had to give the properties of her deceased husband to the Emperor Frederik III Habsburg.¹⁰⁹ The Celje Princes' manors of Polland and Gottschee became the Habsburg property for next century and a half, a century after Ortenburgs gave several Polland hides as a feud to Zobelsberg nobles in 1359.¹¹⁰

The first Gottscheerland Parishes belonged to the archdeaconry of Slovenian Mark or Krajina (Carniola). The oldest parish of Ortenburg possession south of Ljubljana was Ribnica and from there they led the secular and religious government of all their south province for a long time. On September 1, 1339, the Aquileia Patriarch Bernard permitted Otto V Ortenburg (* 1292; † 1343), a son of Frederik I, to install a priest in Mooswald chapel of St. Bartholomew in the areas of today's Gottschee. On May 1, 1363 1339 the Aquileia Patriarch Ludwig II della Torre¹¹¹ in Udine permitted Otto's nephew Otto VI Ortenburg,¹¹² a

husband of the Barbara's relative countess Anna Celjska, to suggest the priests for their superior Ribnica rector's confirmation in churches of Mooswald (Gottschee), Polland, Kostel, Ossiunitz, and (Gottschee) Rieg called Göttnitz.¹¹³ The permit was not the document of establishment or even of erecting of those churches. In Stari Trg of Polland the church worked at least a century earlier. The parish Göttenitz (Gotenica) was established in the year 1845 and did not have a priest before the year 1786. Therefore, Ludwig II certainly meant a neighboring (Gottschee) Rieg where a priest Johannes Zink,¹¹⁴ the scribe of Margareta Teck at the first place, pastured the souls already before the year 1377 as a successor of priest Melhior mentioned in the year 1375.¹¹⁵ The clever Zink fathered several children,¹¹⁶ but didn't have much to do with the famous Margaret's half of the apple because he died three years earlier. His supposed great-grandson Clement Zingale was noted among the last subjects of Rieg where he cultivated the half hide in 1498.¹¹⁷ Zink was strictly speaking the only Swabian settler from the original settlement whose destiny is eventually clearly documented for the future researchers. His nephew Burkard Zink¹¹⁸ described his life when he escaped from his evil stepmother in 1407 to study in Ribnica school for seven years.¹¹⁹ Burkard Zink left the areas before the Celje magnates took them over, but he was aware of their mighty positions.

Bayern, sowie deren Nebenlinien. In: Ostbairische Grenzmarken. Passauer Jahrbuch für Geschichte Kunst und Volkskunde. Nr. 36, Passau 1994).

¹¹³ Schumi, 1882, 31; Steska, 1896, 117-118; Žagar, 1983, 140; Ožura, 1995, 9; Widmer, 2001, 15; Lucijan, 1995, 12.

Ambrožič (2007, 12-13, 15-16) took Otto VII for Otto VI

¹¹⁴ Johannes Zink (Zengg, * Memmingen; † 1415).

¹¹⁵ Troha, 2003, 17.

¹¹⁶ Ambrožič, Ferenc, Zupan, 2007, 26. According to Steska (1896, 118) Ossiunitz was in those times just a branch-church and became parish only in 1509. Skubic (1976, 52, 632-633) connected the document of 1363 with Land Estates establishment of all five listed parishes, he just moved Gotenica to Rieg and Kostel to Fara. Steska noted (1896, 119) that mentioned sites were previously settled and the document just listed the names of the areas. Several churches in Gottscheer Land were not mentioned in the document, among them Koprivnik which became parish in the year 1400.

¹¹⁷ Urbar 1498, 9.

¹¹⁸ Burkard Zink (* 1396 Memmingen; † 1474 Augsburg).

¹¹⁹ Ambrožič, 2007, 26; Schröer, 1870, 18.

¹⁰⁸ Štih, Peter. 1996. Celjski grofje, vprašanje njihove deželno knežje oblasti in dežele celjske. Grafenauerjev Zbornik (ed. Rajšp, Vincenc). Ljubljana: ZRC SAZU, p. 235.

¹⁰⁹ Grdina, Štih, 1999, 19; Simonič, 1939, 67.

¹¹⁰ Kos, 1991, 81.

¹¹¹ Ludwig II della Torre (* 1338; † 1365).

¹¹² Otto VI Ortenburg (* 1338; † January 29, 1374 (Friedrich Hausmann: Die Grafen zu Ortenburg und ihre Vorfahren im Mannesstamm, die Spanheimer in Kärnten, Sachsen und

Herman II of Celje and his grandson prince Ulrich were the only ones able to challenge the Habsburg supremacy on the ancient Argonautic Sava and Danube rivers including the Ljubljana areas. Herman wished to rule the world and to get as much as possible into his hands. He liked his friends of Teutonic Knights' Order whom he helped in their wars against Prussians in 1377. Herman II kept the famous coup of St. Grail (Graal) in his Styrian castle of Rogatec¹²⁰ but he was convinced that the amulets of his Order of Dragon could be even more powerful. His favorite rigorous Carthusian order of the Catholic Church successively established four monasteries in Slovenian Lands: in Žiče (1164), Jurklošter, Bistra (1260), and finally the Monastery of Pleterje south of Ljubljana on Herman's own orders. The people wondered why the rigorous Carthusians founded so many monasteries in the lands inhabited with Slovenes, but their goal was obvious: they knew that Herman needed them, and they hoped that Herman will help them to keep their strongholds. The clever Herman knew what the Carthusians are up to and therefore supported the Pleterje monastery not to miss his share of the divine opulence with Carthusians' monasteries now encircling Ljubljana from all sides.

Herman II of Celje urgently needed the connections with the very top networks because he wished to rule the world. In 1405, he engaged/married his daughter Barbara of Celje¹²¹ to the future Emperor Sigmund of Luxemburg¹²² elected in 1433. The naughty Barbara's brother Frederik performed some disputed love affairs in his castle above Gottschee,¹²³ and Barbara's nephew and final hope Ulrich on his way to the top of European politics forgot to make enough children of his own. The Italian visitors respected the mighty Celje court but dismissed their poor education with no major schools or universities founded in the area, although there was some rumour of future Bishopric of Celje. Barbara was different

from the most girls of her age: powerful, wild, and on search of the secret knowledges urgently needed for her alchemical pursuits. When her dreams finally came true and she got her crowns which extended her jurisdiction even to Ljubljana and deep on the East, she was overlapped with joy. She smelled her precious alchemistic-astrological goals somewhere in the vicinity while her imperial husband was busy with his Hussite wars. When she finally found out her own Ars magna, her poor old husband died, and her power slowly vanished together with his soul. She was never able to put her foot into Ljubljana again and passed away on the eve of Gutenberg's¹²⁴ printing era borrowed from the Chinese networks which could have pleased her so much.

The Jason-Medea's Golden Fleece was all but forgotten and Barbara's relative duke of Burgundy Philip the Good established the prestigious order with that name of Golden Fleece of Jason's memory in 1430, with a sovereign usually on the top position of the order. Barbara liked the idea but as a female she was not invited to become a member, while her husband was too busy anyway. Barbara was deeply disappointed because as the full member of Dragon Order she expected to enter also other similar organizations.

Later the Spanish and Austrian branches of the Golden Fleece order gained their prestige with Habsburg rulers on the top positions of the order of Golden Fleece and Auerspergs also included on regular basis began with the first great Carniolan researcher of vacuum the prince Janez Vajkard Auersperg. The most alchemistic-astrologic of all emperors worldwide Rudolf II of Prague joined the order, and almost all emperors followed him while producing gold with their assistants' stones of wisdom in their spare times. Herman's son Frederik II of Celje married a Frankopan girl Elizabeth in unhappy coupling which Frederik ended similarly as Margaret ended her own four years earlier. The unhappy marriages sometimes bring happy offspring and Ulrich II of Celje¹²⁵ was supposed to be one of them. Barbara put all her hope for her successful Balkan politics on her young nephew Ulrich who son betrayed her hopes as the supporter of Barbara's Habsburg grandson. The new upstarting Celje

¹²⁰ Likar, Silvo. 2007. *Vloga viteških redov na obrambnem in karitativnem področju s poudarkom na Nemškem viteškem redu na Slovenskem*, Graduate work (Diplomska naloga). Teološka Fakulteta Univerze v Ljubljani, mentor Bogdan Kolar, 61-62.

¹²¹ Barbara of Celje (Cilli, 1392-1451).

¹²² Sigmund of Luxemburg (1368-1437).

¹²³ Mlinar, Janez, 2016. *Povednost srednjeveških urbarjev*.

Primer belopeškega urbarja iz leta 1498, *Urbarji na Slovenskem skozi stoletja* (ed. Bizjak, Matjaž; Žnidaršič Golec, Lilijana), Ljubljana: Arhiv Republike Slovenije, 35.

¹²⁴ Gutenberg (1398-1468).

¹²⁵ Ulrich II of Celje (1406-1456).

counts-princes were successful in everything except in the legitimate children-making after Herman II ceased to do that job. With the Aquileia Patriarch as their perpetual guest in Celje they also planned the seat of Bishopric there while they made no move to establish the higher education enterprises outside the church. Kostel castle was one of their favorite strategic strongholds, therefore they rebuild it and enlarged the old Oldenburg castle there. After the sad year of Herman II's death in 1435 the extremely happy Celje counts' year 1436 followed with their newly acquired title of imperial princes in their pockets. It was no surprise as the empress was the sister and aunt of both newly promoted princes, the alchemic ruler Barbara. The newly appointed prince Frederik noted that Barbara did not wear any usual black dress to commemorate their father's recent death: "What's up Barbara? I supposed you will be still in black because of our recent tragedy in the family?" Barbara felt much better in her lighter colors: "Our father died – so what? He was rather old, and you probably hated him anyway because he ordered the murder of your lovable Veronika?" Frederik was rather upset. He waited a little before he spoke in a low voice after he drank and eat his share of the meal: "Our father died – then what? Please speak more quietly, Barbara. My son Ulrich should not hear anything like that! He is already in his late twenties, but he is still a kid, a kid deeply in love with his grandfather. I do not mean much to Ulrich - his grandpa was all to him. If Ulrich anyhow happen to learn anything about your crazy statement 'our father died – then what?', Ulrich might become your sworn enemy. For my part, my heart died with Veronika. You knew her very well as she certainly was an angel. But that was a decade ago. The father was wrong, now we have just Ulrich to keep our dynasty afloat and Ulrich's firstborn George is not a very strong kid. Veronika would be a perfect mother, but it's a buried past now. I died with Veronika, but I also forgave our father, even in Veronika's name. A guy cannot live with such a hatred in his heart, not me. Our father was crazy in his pushing to the top, you are quite right about that. But, there is another side of the medal, he did all he did for us, for us who are his family..." Barbara did not agree at all: "Your son Ulrich is like a brother to me because he isn't much younger than me, a dozen years or so. Still, I cannot talk to him openly. 'Our father died – then what?' is sad but true statement. Yes, our father

accumulated enormous property in his lifetime, together with the great political forces to serve his goals. Otherwise, he was a fool. He had no understanding of the symmetries of nature where a guy must be in balance with both of his dual equally strong Chinese principles of yin-yang as Marco Polo recently reported. Our father was wrong because he swore just on one half of the principle while he was accumulating all the time, and never donating much except for priests and monks. The Bogomilist Bosnian promoters are also wrong because their dualism endorses one pole as the evil one and not as the equivalent to the other. The legendary Dzhou Yen¹²⁶ did better in China some eighteen centuries ago. Dzhou Yen disliked our four bases while he promoted the Taoist five bases without gases involved called wu xing (wu hsing, 五行, metal, wood, water, fire, earth) combined by earthy female yin and heavenly masculine yang. On Dzhou Yen's merits the king of the state Qi (Chhi) established the academy Jixia (Chi-Xia) in 318 B.C. six decades after Plato's Athens Academy. Certainly, the Chinese academy was made with somewhat different goals, because the Chinese are different compared to the European Christians. Later in 221 B.C. the ruler of the state Qin (Chhin) Qin Shihuangdi (Chhin Shih Huang Ti) united all Chinese states as a firm believer in the elixir of eternal life with the alchemists employed at his court, the elixir of life which I'm also searching for. Little before 169 B.C. Liu Yan,¹²⁷ the Han prince-ruler of Huainan, gave to his nephew the 5th king of Han-Chinese dynasty the book *Huai Nan Zi* (Huainanzi). The book contained the very best description of five elements and the fire as the female qi in dualism of Yin-Yang male-female qi compiled by his Huainan eight immortals visiting scholars. Based on those equivalence principles, the Chinese have a great state already for millennia, while our European Hermans and Sigismunds, my fathers and husbands, just grab as much they could for their dynasties which all too soon sadly collapse because they forgot to produce their own children..."

Frederik had to empty two glasses of wine before he could understand all the facts his sister was filling

¹²⁶ Dzhou Yen (Zou Yan, Tsou Yen. 鄒衍, about 305/340 B.C.-240/250 (Grdenić, Drago. 2003. *Alkemija*. Zagreb: Jasenski i Turk, 195)).

¹²⁷ Liu Yan (Liu An, 177/179 B.C.-122 B.C.).

his poor head with. After a while, he took a deep breath and demanded: “You became quite an erudite, my baby sister. I’m so proud of you, I really am. You do talk with such an erudition that I do not understand almost a half of your speech.” Frederik took another deep breath: “OK, my nice Barbara. Let’s do it your way. You could wear your light dresses for a while even if the people already refer on you as the famous black queen. But do not tell anything naughty to Ulrich because you might upset him, and his anger is much quicker than his mind. You will have a dress as you wish, but we will move the celebration to periphery where folks do not know much about our father’s recent death and your nice costume will not get criticized too much. We could pass by mine and Veronika’s castle and ride some 25 kilometers down south to Kolpa river and make our fest there. To celebrate the happy princely event. Then we should take a ride to Kostel to hear the special mass in Fara St. Mary’s church which good old Hans Schwab of our father’s generation had finally built. Their renter of three hides under the church Kristof Reuter just passed away, so we could also celebrate the new owner of those hides, the brand new Kostel leaseholder Ivan Schrabas.¹²⁸ The knight Ivan of Svibno-Planina landlords with their main property in Krško was supposed to pay for our festival there and he will bring some good Styrian wine for the occasion. The nobles agreed, that after Ivan’s death the three Fara hides and whole manor will pass to Volklein Auersperg,¹²⁹ the oldest son of Theobald (Diepold) II from Turjak manor. Volklein could keep Kostel until Volklein’s own death.¹³⁰ Your husband the emperor will not come to join us as he is already very ill...” The alchemistic chick Barbara was all for the party and all the flowers of the local nobility joined them. Most of the folks agreed: “Those Celje masters were not bad except that they liked to hunt the local girls. They were not a kind of proud learned nobles who carry their heavy books and speak their awful polite Latin which even our learned priest Kajclin does not understand. The literary ambitions of Celje lords were never great as their visiting Italian diplomats recognized very well.

All they wanted is power, a great power, and they used to be loud heavy drinkers and eaters. Their Slovenian language has that heavy Styrian accent, but they are like one of us, although they are enormously wealthier.” So, the locals approved the Celje magnates’ roughness and they repeated the jokes about their love affairs with a secret wish that their own wife or daughters would not be involved. Those celebrating folks just did not imagine how close might be the end of the mighty Celje princes’ dynasty which came within a decade.

The Celje magnates recently acquired friends of the noble family of Auersperg may also have originated from Teck’s Swabia, namely from Ursberg. No matter what was their real origin they were already intermarried with different local Slavic and German groups for centuries when Habsburg finally got Gottschee and upper Kolpa manors in their hands after the brother of the future Hungarian king Matjaž (Mathias) assassinated Ulrich II of Celje¹³¹ in Belgrade. Habsburgs and Auersperg knew their job better than most of their competitors and always produced a lot of male children except in Maria Theresa’s later case. The Habsburgs were also able administrators and soon ordered the listings of their subjects’ taxes in Gottschee, Kostel, Polland and other manors in 1490s. They wished to know how wealthy they were, and how many new subjects they got from their recent northern and southern migrations on Oldenburg behalf.

The emperor Frederik III Habsburg’s¹³² Kostel leaseholder Volklein Auersperg¹³³ already passed away, therefore the emperor leased Kostel to Volklein’s daughter Susanna Auersperg who died in 1486 as a wife of her second husband Andreas Hohenwarth from the manor Kolovec north of Ljubljana. Andreas, his brother Stefan, and their father Erhard already got Polland (Poljane) manor in their leasehold in 1466. Andreas was therefore one of the rare fellows who managed Kostel and its eastern neighboring manor Polland altogether, which enabled him to switch some hides of the milers near the border of both manors from one manor to another. Andreas offered a lot of money to Frederik

¹²⁸ Ivan Schrabas (Hans Schrabass, Schrawass).

¹²⁹ Volklein Auersperg (Volkhard, Volker Turjaški, 1401-1451/1454).

¹³⁰ Three hides of future villages Mavers or Stelnig under the castle, or Fara under the Fara church, or even Slavski Laz (Južnič, 2008, 24).

¹³¹ Ulrich II of Celje (1406-1456).

¹³² Frederik III Habsburg (1415-1493).

¹³³ Volklein Auersperg (Volkhard, Volker Turjaški, 1401-1451/1454).

III, who gave him on return also the leasehold of manor of Ribnica on May 10, 1470, Ravbar's castle of Mengeš in 1479, and Krupa manor in Andreas' final year of 1483. Andreas died under Muslim Turkish-related sable in the year 1483¹³⁴ after he used to be the governor of Celje, Provincial Governor of Carniola in 1467, and Metlika General Governor in the next year.¹³⁵ Andreas's violent death was a sad event for his son who had the same name Andreas. After Frederik died, the new emperor was proclaimed in the person of his son Maximilian I Habsburg.¹³⁶ Maximilian appreciated Andreas' familiarity with domestic affairs of Kostel. Maximilian ordered the tax records called urbars to be completed for all his manors including Kostel which was in Andreas Hohenwarth's leasehold. The emperor told Andreas: "Well, my noble dear, the new times are approaching. The way my and your father, may God bless their souls, run our lands, that funny way is no longer appropriate. The Italian Genovese-Florentine-Venetian double bookkeeping and Fugger's Swabian Augsburg business enterprises are now modern and there is no way we could avoid a reform of our enterprises."

The Habsburg guys might have been wealthy, but Barbara surpassed them all in her times. At the wedding, her royal husband signed for Barbara a contract on her widow's possessions which contained a huge territory, cities across Hungary, the mining towns in Slovakia. This would allow the widowed Hungarian queen a decent life, but only if she does not remarry. After the emperor's death, his widow should stay a widow if she wanted to enjoy all those goods. The contract was restricted to her yearly salaries of 28,000 guilders, while the surplus was due to the royal treasury. Her management also included Krems on Danube with Chamber of Commerce and Mint, as well as receipts from the mines of gold, silver, lead, iron which suited Barbara's interests in alchemy. She got financially very lucrative property, which likely made her the

¹³⁴ Skubic, 1976, 341-342; Smole, 1982, 620; Južnič, 2008, 26; Simonič, 1939, 69, Južnič, 2009 *Dvig*, 15, 388; Podlogar, 1921, 103; Žagar, 1983, 67; Bidermann, 1882, 141, 185; Južnič, 2005, 71, 81.

¹³⁵ Južnič, 2008, 25, 34.

http://www.waymarking.com/waymarks/WMT8A8_Andrej_H_ochenwartskii_Castle_Chapel_of_St_George_Ljubljanski_Grad_Ljubljana

¹³⁶ Maximilian I Habsburg (1459-1519).

richest woman in Hungary. On her eternal sorrow, her lands and domains were repeatedly devastated by the Muslim intruders.

Between Barbara and Sigismund in their marriage there were apparently not too many problems, because they were much apart during Sigismund's journeys which carried him happily away from Barbara midnight hysteric escapades. Sigismund has traveled a lot through his territories, because the only way to find out what was really happening on his huge estates was to be there in person. When in April of 1419,¹³⁷ after six years, king returned to Hungary, he judged Barbara's regency up to date as unsatisfactory with regards to the Žižka's Hussite and Turkish threats of the Muslim intruders.

In 1422, Barbara's husband Sigismund had arranged their daughter Elizabeth's marriage with Albrecht V of Habsburg who supported him in the Hussite Wars. By marrying Sigismund's daughter, Albrecht also became the successor to the Holy Roman throne which was the option Barbara did not like very much. In fact, her astrological fortune-telling predicted the space of time of Habsburg Holy Roman and related ruling in amount of almost half of the millennia, which was much to long for Barbara's taste.

Despite of Barbara's doubts, the alliance with Habsburgs was a great success of the politics of Barbara's husband Sigismund and Barbara's father Herman. Still, there were many that were nasty to write about Barbara and emperor's repeated splits. Particularly, it happened that the historiographical opinions about Barbara were very negative for centuries, mostly because she was not very supportive for Habsburg Holy Roman and related ruling which lasted for almost half of the millennia, while Barbara's and her husband family houses disappeared in male lines with nobody there to defend Barbara's whereabouts. The woman Barbara, who knew how to deal with money well enough to help her husband the king, was presented as an unbeliever and a politically ill person, a kind of person with too much ambitious. Her employment with alchemy was put in a questionable light. Some

¹³⁷ Katanec, Sara. 2014. *The Perquisite of a Medieval Wedding: Barbara of Cilli's Acquisition of Wealth, Power, and Lands*. MA thesis, Budapest, 70.

writers find this seemingly symptomatic. A similar story had been reported by historians to Barbara's contemporary Isabeau de Bavière, who temporarily represented her husband the French king in the Parisian government.¹³⁸

Besides Enea Silvio Piccolomini, the Krakow bishop's secretary priest Jan Długosz¹³⁹ also extensively wrote on the affairs of the daughters of the magnates of Celje. Długosz' first section included notices which were linked to Anna of Celje, the daughter of the Count William (Wilhelm) of Celje deceased in 1392. Długosz mentions her arrival to Poland, her marriage to a Polish king, and Władysław II Jagiełło's coronation with Anna. Anna's mother Anna participated in the feasts. After the death of her first husband William, Anna's mother Anna remarried to the Earl of the family Teck. Anna criticized her daughter and namesake: "Dear daughter of mine, I'm glad that you are showing me your wedding dress before the marriage ceremonies. But I must disappoint you: that material of your costume is no silk at all." The younger Anna was greatly surprised and sad. She nearly put some tears in her eyes: "Dear mother, it can't possibly be true! I spent a lot of money for the dress and the merchant assured me it's pure silk, the purest of them all." The mother touched the face and hair of her only daughter with affection but continued her serious remarks: "That awful trader of yours must be a crook, a great cheater. I will get him caught one of these days, please be sure of that. To cheat a bride in her wedding day, well, that's the crime of all crimes, I tell you. I'm so sorry for you, baby, I did not spend enough time with you when you were a kid to teach you the lesson about this world full of dishonest merchants. The real dress made of silk should be so thin, that you could pack it in a small box. This dress of yours is very far from that kind. Your supposed Russian ancestors knew those things very well as they lived much closer to the Chinese producers of silk that we do. Next time, my poor daughter, try to put me in charge for your new dresses, and I will use my connections with the honest travelers who have their almost direct connections with the well-hidden Chinese ways of producers of silk..."

¹³⁸ Bader 1942

¹³⁹ Jan Długosz (Ioannes, Joannes, Johannes Longinus, Długossius, 1 December 1415 – 19 May 1480).

Despite of Anna the younger's wedding dress or because of it, very soon there was the crisis between the royal couple which erupted in 1407, when Władysław II Jagiełło accused his wife of adultery.¹⁴⁰ Probably in 1412 Anna has played the role of a kind of secret diplomat of her Celje relatives. Under the pretext of visiting her relative Barbara as the daughter of Anna's uncle Herman and the wife of Hungarian king Sigismund, Anna was transmitting the notes between Sigismund and Anna's husband, Władysław II Jagiełło. Anna and Barbara managed to negotiate a personal meeting of the two kings. Długosz mentioned Anna's death in 1416, when the grieved Władysław II Jagiełło ordered the full sorrow to all Polish churches in her honor during her funeral ceremonies. In Długosz' notices Anna was primarily a function element legitimizing Władysław II Jagiełło's rights on the Polish throne. Władysław II Jagiełło from the Lithuanian dynasty of Jagelonians got the crown in 1386. Then he baptized quickly and married with a daughter of already deceased Hungarian King Louis named Hedviga. In this way, he became a co-ruler of Hedviga, who has been on the throne since 1382. With Hedviga's death in 1399 Władysław II Jagiełło's Polish crown lost its legitimacy and Władysław II Jagiełło was even willing to give up the throne. At least Długosz thought so, even if it is a kind of improbable story because the folks naturally like the power and very seldom decide to abandon it by their own free will. In any case, by marrying Anna Władysław II Jagiełło was back in the saddle again.

Barbara and her cousin the adopted sister Anna, both married the kings. Anna's husband first wife was affiliated with the Christianization of the local areas including Baltic lands which made her a saint. Anna was not that lucky when she became the second wife of Vladislav II Jagello (Władysław II Jagiełło) in 1402 after the death of his first wife Hedviga (Hedwig) of Anjou. Like their ancestors, Anna and Barbara were known for their toughness, passion, and indulgence. "She was a very sensual woman," wrote about Barbara the humanist Aeneas (Enea) Silvius Piccolomini. "She even supposedly banned her maid's prayers." Barbara of Celje was reportedly energetic woman and her husband, allegedly due to

¹⁴⁰ Further Długosz' notice in his chronicle.

her infidelity, took revenge and told her to go to Oradea in 1419. After the reconciliation, Barbara received the huge payments from Central Slovakian mining towns, Zvolen Castle, Trenčanský Castle, and several castle domains in 1424 and afterwards. Barbara still rather acted against the interests of her husband. Since 1436 as a Bohemian queen Barbara led diplomatic relations with the Czech statesmen in their maternal Czech language. She was closer to Utraquists Hussite than to the Catholics, which was not her husband's wish. As the Empress Dowager, she opened new possibilities a year later. "That woman, already an old woman," said Aeneas Silvius (Enea Silvio Bartolomeo Piccolomini) about Barbara, "have the intention again to marry, after she was banished from the mind of her daughter who grew up in the hope of the throne and married the Austrian Duke Albrecht. In that situation, Barbara did not think about anything other than the joy of a new marriage." Barbara was going to marry the heir to the throne of Poland, who was then a teenager of only thirteen years of age. Barbara secretly wished to be again in the Krakow on the post of her adopted death sister Anna. Her plans failed mainly because of the power of her daughter and Barbara's son-in-law Albrecht.

3.2.1.7 Alchemy, the Queen of us All

After Barbara's politics failed, Barbara devoted more time to her intellectual and alchemistic-astrological interests designed to produce the new materials. To learn more about Avicenna's Muslim astrological-chemical pursuits Barbara even sent her nephew Ulrich with his sixty knights to the Iberian Santiago de Compostela near the center of Moorish learning. Barbara's power was not entirely in her politic-diplomacy as soon as she learned that her reputations of astrologer-chemist brings in even more admirations of her networks. The politics became Barbara's tool to learn more about astrology-alchemy, which was diametrically opposite to the approach of most of her Celje family members.

Barbara had not accompanied Sigismund to his imperial coronation in Rome in 1433 which formally deprived her from the crown and the related titles as the only medieval Roman princess who failed that formality. Even more frustrating, she was not

allowed to attend the solemn funeral of her own husband, something like the humiliations needed to diminish her power as much as possible. Barbara's son-in-law Albrecht of Habsburg and Barbara's angry daughter might also have been instrumental in the battles against Barbara's influences. Both Sigismund and Albrecht's networks saw in Barbara an antagonist who had enough power to disable Albrecht V as the successor to the Bohemian and Hungarian royal thrones.



Figure 3-6: The title page of Laaz' alchemical book containing the stuff he previously learned from Barbara, with a note of the year 1448 as the time of writing.

After the Hussite Wars, the royal couple temporarily reconciled, and Barbara was crowned Queen of Bohemia which greatly approved her merits in Prague astrological-chemical circles. All doors were opened to her at once. On 11 February 1437 in Prague Barbara was crowned Queen of Bohemia in her own right just several months before her husband passed away. Therefore, Barbara's happiness in Prague did not last long. As a widow, she became an easy target for her daughter and for Barbara's nephew Ulrich. In 1441 just before the death of her only daughter Elizabeth, Barbara left for Mělník which was the usual resting place for the widow of the king of Bohemia.



Figure 3-7: Laaz' beginning of the book reportedly finished in 1448, eight years after he visited Barbara.

Very early in her public life, Barbara of Celje (Cilli) became famous for her dealing with astrology and alchemy. She frequently left her Mělník castle for her Celje family castle of Samobor 20 kilometres west of Zagreb and 90 kilometres southeast of her native Celje. Already on September 28, 1408, Barbara had her court in Samobor where she issued the order on important administrative matters of Zagreb folks¹⁴¹ while she developed her alchemistic lab in the basement of her Samobor castle. Later, Barbara's father was the Ban of Slavonia including Samobor during the last dozen years of his life.¹⁴²

After their father passed away, Barbara's brother Frederik was formally in charge in Samobor, but Barbara was more than his match. Barbara spent most of the time in the basement of the Samobor mansion which she transformed into the laboratory for her alchemistic experiments. Her own notes on her alchemic pursuits were not maintained because Barbara was the wealthiest female in Hungarian kingdom which made her quite reluctant to admit to

¹⁴¹ Katanec, Sara. 2014. *The Perquisite of a Medieval Wedding: Barbara of Cilli's Acquisition of Wealth, Power, and Lands*. MA thesis, Budapest, 66.

¹⁴² Katanec, Sara. 2014. *The Perquisite of a Medieval Wedding: Barbara of Cilli's Acquisition of Wealth, Power, and Lands*. MA thesis, Budapest, 69.

the crowd that she is making some false precious metals in her laboratories. As the member of the highest nobility Barbara had no intentions to make her research public as the ordinary literati usually do.



Figure 3-8: Reprint of Laaz' booklet under the title Joannes de Lasniore. *Tractatus aureus de Lapide Philosophorum*, In: Zetzner (ed.). *Theatrum chemicum, præcipuos selectorum auctorum tractatus de chemiæ et lapidis philosophici antiquitate, veritate, iure, præstantia et operationibus, continens...* Volumes I-IV. (Ober)Ursel: Zetzner. 1602. Reprint: 1613. Strasbourg: Zetzner, 4: 579-584. Here is first page 579.

The uneducated crowd is one thing a clever guy must be aware of, but the alchemical-astrological networks of Prague and Hungary knew very well all about Barbara's merits. The best extensive critical testimony of Barbara's alchemistic work was obtained from the records of her alleged visitor, the Bohemian alchemist Johannes from Laaz (Ledce) south of Brno in Moravia. Laaz authored *Tractatus aureus de lapide philosophorum* and claimed in the subhead and again in conclusion of his *Tractatus II de lapide philosophico* to be the student of alchemist Anthony of Florence (Antonius de Florentia), who was supposedly murdered in Bohemia¹⁴³ in a kind of the alchemistic complot. In the *Tractatus* Laaz's

¹⁴³ Benedek Láng. 2010. *Unlocked Books: Manuscripts of Learned Magic in the Medieval Libraries of Central Europe*. Penn State Press, 157.

editor finally noted the year of 1448 as Laaz's times of writing. In the advanced part of his tractate¹⁴⁴ after the detailed instruction on handling mercury, sulphur, and arsenic, Johannes Laaz connected his divine magisterium with the works of the new philosophers as were Hermes and Thomas Aquinas. The mercury mine of Idrija was not in operation in those days yet, therefore Laaz and Barbara got most of their quicksilver from Spain, especially after Barbara's nephew Ulrich made a pilgrimage journey to that part of the world.



Figure 3-9: Laaz' booklet with notes on Hermes and Thomas Aquinas on p. 572 and data on Joannes Lucianus on the last page 584 under the title Joannes de Lasnoro. Tractatus aureus de Lapide Philosophorum. In: Zetzner (ed.). Theatrum chemicum, præcipuos selectorum auctorum tractatus de chemiæ et lapidis philosophici antiquitate, veritate, iure, præstantia et operationibus, continens... Volumes I-IV. Zetzner, Ursel. 1602. (reprint: 1613. Strasbourg: Zetzner), 4: 579-584. This Picture was attached to the page 584 to indicate Laaz' allegations about connections between metals, their conversion, solution in water and celestial bodies as Laaz debated them gladly with Barbara of Celje before they quarreled. Johannes from Laaz connected his instructions of their alchemy with the gradual reduction of the full moon of the eight lunar

stages. Of course, he did not use the heliocentric system which Copernicus promoted only a century later, although the central figure in the Sun also attributed a central position between the planets. At the same time on left part of the page in the first sentence, he denied the force of the Sun, and noted the preciousness of water baptized into wine on the right side. In the final sentence, among the other eight beauties, the Moon relied on Ennead (Enneadem, nine, Greek: Εννεάς, Egyptian letter Pesedjet) as the Assembly of the nine major Egyptian Osiris (wsjr, jsjrt) deities. They were Atum, Shu, Tefnut, Geb, Nut, Osiris as a God (mortal) change, Isis,¹⁴⁵ Set, and Nephthys, while the Ennead perfect hint as the sum of all the Gods. Johannes Laaz used the famous Nine Ennead obviously plus a famous son of Osiris and his sympathies were put on a versatile Isis called Horus (Hor). In that way Laaz won the universal number ten palatable. According to Laaz and probably also according to Barbara's belief, eight lunar Monads (elements, units, Greek: μονάδες) were created for all people with universal Eneado number ten. Then fountain main red light again pours into Nabathea eyes, probably connected with commercial influential Arab tribe of the Kingdom of Nabatea in the days of Christ.¹⁴⁶ Occult interpretation of the final instructions for the great process of alchemy called Ars magna from the coffers of transmutations made by Johannes from Laaz who shared Barbara's beliefs regardless of the amount of gold that any of them may create by the mysterious mishmash of their promising chemicals that could undoubtedly also help the contemporary impoverished folks.

Besides sulphur and mercury, Johannes Laaz also advised the use of ones' own naturally produced sperm, female liquids, and blood after the triple distillation. The distillation of those days was quite a novelty which the Arabic traders introduced in

¹⁴⁵ Transformed into a name of modern Islamic State; Isis (Aset, Iset) was Oziris's maid and sister as the protector of nature and magic, which is not entirely in the frame of Islamic State as interpreted by Trump, Putin, and most of all Merkel.

¹⁴⁶ Octas in monadam lunae projecta creat Enneadem, è quibus omnibus Decas oritur numerus omnis atq, universus. Ubi tamen fulvus fons fundit oculatam Nabatheo cardine lucem (The eighth casted monades of the moon create the Ennead, the number of all of which gives rise to all the ten, which is all the men. There, however, the fountain of the red light pours forth of the hinge in the eyes of Nabathea).

¹⁴⁴ Johannes from Laaz. 1611. *Tractatus II de lapide philosophico/ Tractatus aureus de lapide philosophorum*, page 8, unpagged.

Europe from the Chinese headquarters mainly for alchemistic or medicinal purposes while the first alcohol distillation was available in the Italian school of Salerno just several decades before Laaz put his foot in Barbara's lab. The strong alcoholic distilled spirits gained their popularity already in Barbara's era, but she served none of them to Laaz because she preferred to keep Laaz' head sober. Barbara was aware that the Chinese Yi Di made great efforts to make mellow wine with fermented glutinous rice. She even knew about Du Kang,¹⁴⁷ who lived or even ruled during the Xia Dynasty¹⁴⁸ and invented making top-notch liquor with Chinese sorghum beans.¹⁴⁹ But Barbara was a kind of early feminist, therefore her favourites were the female Alexandrian proto-chemists focused on metallic transformations, while the eternal life was not their greatest goal. Barbara liked mostly the legendary Maria the Jewess¹⁵⁰ who used her water baths and *kerotakis* to collect vapours in sealed vessel with copper sheets in vacuum. For Barbara, her predecessor Maria the Jewess was considered as the earliest proto-European, or in fact rather African alchemist and the earliest female user of the vacuum producing techniques which also pleased Barbara. The Alexandrian researchers pretended to be useful in industry, which made them suspicious in the eyes of the Roman Emperor Diocletian of Split and almost similar fate dogged the Chinese alchemists four centuries and the half before Diocletian. As a ruler, Barbara was far from being opponent of any kind of alchemistic research. Just like Barbara herself, the Muslims had considerably less fears of the alchemists' secrets compared to Han-Chinese of Catholic Europeans. The Arabic alchemists introduced the distillation from Chinese, Alexandrian, and other networks for the processing of etheric oils in 9th century and of wine in 11th-12th century while the discovery of the distilled alcohol maybe took place in South-Italian Salerno Medical School. The alcohol was used just as a remedy primary against the black death pest up to 13th and 14th century until the strong drinks widely

spread in 16th century¹⁵¹ as a kind of strong intoxication.

The fractional distillation of Florence born alchemist Taddeo Alderotti,¹⁵² who used to be the professor of medicine at the Bologna University before he retired to Venice, was still a novelty in Christian European headquarters. The fractional distillation was one of Laaz's favourite tools as he spent much of his times in Italy and learned all the details almost from their very sources. The technical details of fractional distillations were one of the top Barbara's priorities and one of the main reasons why she welcomed Laaz' visit to learn more about the new Italian technologies borrowed from the ancient Chinese headquarters although Alderotti died few years before Marco Polo's Chinese travelogue was available after Polo's supposed narration in Genovese prison in 1298/1299. For one reason or another Barbara failed to visit Italy for her husband imperial coronation in Rome on May 31, 1433, which made her very willing to hear all which Laaz possibly could tell her about the new Italian inventions.

The alchemists like Barbara and Laaz considered the colour as the most important sign of change of their artefacts.¹⁵³ The Sun, Moon, and five planets corresponded to the seven metals which sometimes exchanged their connections with the nebular objects. Barbara took a great interest in a stuff like that and tried to learn more about it from Laaz who was also known as a kind of magician. The short independent addition to Johannes Laaz' text was dedicated to the abbot Johannes Trithemius (1462-1516) who became famous with his cryptography and supposed magic, although he did not really approve the alchemy.¹⁵⁴ Barbara was aware of those Laaz' works although Laaz supposedly put them in his final readable form some eight years after he visited Barbara's alchemical lab. As all those novelties, Laaz's opinions widely circulated through the networks of somewhat secret alchemistic communities well before the publication of them in

¹⁴⁷ Shao Kang, 少康.

¹⁴⁸ About 2100 BC-about 1600 BC.

¹⁴⁹ <http://www.drinkingcup.net/chinas-oldest-liquor-du-kang/>
http://www.chinadaily.com.cn/life/2010-10/27/content_11692216.htm

¹⁵⁰ Maria Prophetissima, Maria Prophetissa, Mary Prophetissa, Miriam the Prophetess.

¹⁵¹ Grdenić, 2007, 103, 109.

¹⁵² Thaddaeus Alderottus, Thaddée de Florence, 1206/1215-1295.

¹⁵³ Grdenić, 2003, 50, 52.

¹⁵⁴ J.Trithemius, *Steganographia*, Norimbergae 1721, 125, 251, 255.

their final form. Barbara was among the persons with the best social connections of her time and she quickly mastered all the traches and stories of alchemistic community worldwide, even if they were supposed to be the secret ones.



Figure 3-10: The title page of Basilica chimica of Oswald Croll (* about 1560 Hessen-Kassel; † 25. 12. 1609 Prague) falsely but profitably attributed to Basilus Valentinus in a book which the count Volf Engelbert Auersperg (Turjaški) and his brother prince Johan Weikhard kept in their Ljubljana Library.

Johannes from Laaz mainly achieved his fame in Italy, where he worked on aurefaction and transformation of metals with no apparent luck. Due to failures in the transformation of metals he disappointed the local rulers and had to flee from Italy. He got even the funny nickname Lasniuro (Laz-Nien-oro) as the Italian expression for »Laz no gold" which could also have other meanings. After fleeing from Italy, he traveled extensively, learned all about the alchemistic networks around, and wished to learn even more by visiting many alchemistic labs where he tried to figure out the strictly hidden alchemistic secrets. Laaz therefore

also visited the palace of queen Barbara in Samobor and her alchemistic lab in the basement. What he saw and Barbara's trials carried out in his presence were fascinating, not just because of Barbara's knowhow, but also because of Barbara's high social position. Laaz described his experiences with Barbara in his book *Via Universalis* ("universal way"). Part of the text of that Laaz's work was published in the seventh edition of the alchemical work *Currus Triumphalis Antimonii* ("Winning of antimony wagon" or "Triumphal antimony wagon.") which was attributed to the alchemist Basilus Valentinus.¹⁵⁵



Figure 3-11: Barbara of Celje portrayed as a Venus of her astrological pursuits, which was believed to be equivalent of copper of her deepest earthly lab matters (Konrad Kyeser, Bellifortis, manuscript 1360, folio 002v, Bibliothèque municipale de Besançon, first half of the fifteenth century, "Liber de septem signis", Bellifortis-fragment).

Johannes from Laaz wrote as follows on his mishmashes with Barbara: "I heard several rumours of the queen, the widow of King Sigismund of

¹⁵⁵ Paušek-Baždar 2008. Königin Barbara zu Cilli als Alchimistin in Samobor. *Godišnjak Njemačke narodnostne zajednice* 15/1: 277.

venerable memory. All talked about her knowledge in the physical arts, so I went up to her to try it out. She gave me very clever answers. I saw that she took mercury, arsenic, and something else which I did not recognize. She made the powder from which the copper was whitened. That substance did not withstand the mechanical experiment with a hammer although it withstood the scrapping with the sander. In that way, she defrauded many people".¹⁵⁶

The above experiment in Laaz' description was known very well in the alchemist literature for a while. The main part of it was important for bonding of the copper with mercury and arsenic, wherein the compound obtained a silver colour which resembled the precious metal. Pseudo-Democritus already in the 2nd century discovered the secret of changing the colour of copper into the colour of silver,¹⁵⁷ which meant that the procedure was not at all Barbara's invention.

Laaz continued his valuable report, which might have been somewhat adapted to fulfil Laaz's own wishes: "I also saw how she heated copper sprinkled with some powder that she yelled in copper and made her copper coloured as fine silver. When she re-solidified copper, the copper has become ordinary as it was before. She showed me there some more fake arts." Laaz certainly knew the tricks of those sorts because he also used to cheat folks in his good old Italian times. And Laaz testified further: "Next, she took crocus Martis (Crocus Martis - literally "Mars saffron" iron oxide (FeSO₄), which normally contains a proportion of impurity), some saffron of Venus (copper lime), and other powders. She mixed them and thereby cemented all those parts with gold and silver. The metal had the outside and the inside appearance of fine gold, it really looked fine from inside and outside. But when she melted it, the mixture lost its colour. In those ways, she has cheated many traders".¹⁵⁸ The first above described process was also known for a long time in the alchemic literature. The famous Stockholm papyrus (Papyrus Graecus Holmiensis, dated about 300 AD) already contained such stuff as it presented craft recipes written in Demotic Greek script. The Stockholm papyrus had 154 recipes for dyeing,

colouring gemstones, cleaning (purifying) pearls, as well as for the imitation gold and silver. It also reported of bleaching of copper (halkoy leukosis) with the arsenic. The procedure used to be performed with arsenic, so that realgar (red arsenic sulphide, α -As₄S₄, arsenic sulfide mineral, "ruby sulphur" or "ruby of arsenic") and arsenic (poisonous dust, arsenic trioxide) were thrown into the molten heated copper. In the second procedure, the alchemists used Martis crocus (Crocus of iron) or iron (III) oxide Fe₂O₃ for the yellow colour, while copper oxide was red. The hardening in alchemy designated the process of discharge of gold from silver and that was the art which the wealthy Barbara wished to achieve while the poor Laaz was maybe also remotely dedicated to that goal.

In Barbara's laboratory, which she headed with the little help of her assistants, the metals and metal oxides were heated to the glowing temperatures in a container together with a simple salt and copperas, the so-called cement. Thus, the cleansed gold which Barbara got was even much cleaner than the natural one. That kind of gold later in the era of iatrochemistry became very useful as a medicine in the form of thin gold leaves, or in the form of potable gold. The potable gold elixir was indeed the gold dissolved in Aqua regia, which was also called "royal water" or "king's water" as a mixture of alcohol and lemon juice.¹⁵⁹ The funny Laaz's excerpt ended as follows in a spirit of his times which were full of colourful scenes: "I have seen many frauds and scams, so I told her that this reproach of her is bad. She wanted to jail me, but I escaped with God's help."¹⁶⁰ The clever Laaz never explained the way he managed to escape from the almighty queen. His intention was to provide the testimony about the alchemical laboratory research of the wealthy folks as a kind of propaganda for his

¹⁵⁹ Paušek-Baždar 2008: 278-279.

- ¹⁶⁰ Mihael Brenčič. 2017. Alkimija Barbare Celjske, *Idrijski razgledi*. 62/2: 26-36; Fugger Germadnik, Rolanda. 2010, *Barbara Celjska 1382-1451*. Celje: Zgodovinski arhiv/Pokrajinski muzej, page 32; Sivec, Ivan. 2016. *Kraljica s tremi kronami*. Mengeš: ICO, 244-245, 252-256; Benedek Láng. 2010. *Unlocked Books: Manuscripts of Learned Magic in the Medieval Libraries of Central Europe*. Penn State Press, 156. 211; Nicolaus Petrus (ed.) 1717, 1740, *Fr. Basilii Valentini Chymische Schriften*. Hamburg; Kopp, Hermann. 1886. *Die Alchemie in älterer und neuerer Zeit*. Heidelberg: Carl Winters, Volume 1: 60-61.

¹⁵⁶ Paušek-Baždar 2008: 278.

¹⁵⁷ Paušek-Baždar 2008: 278.

¹⁵⁸ Paušek-Baždar 2008: 278.

own up to date failed *ars magna*. As the grandma of the Habsburg ruler Ladislaus V the Posthumous, Barbara was the initiator of a huge row of documented Habsburg alchemistic rulers including the emperors Rudolph II and Leopold I. All of them borrowed from Barbara's lab in all aspects.



Figure 3-12: Barbara of Celje portrayed as a blue Venus of her astrological pursuits, which was in blue color even more equivalent to copper of her more earthly lab matters (Konrad Kyeser, *Bellifortis*, manuscript 1360, folio 002v, Bibliothèque municipale de Besançon, first half of the fifteenth century).

The Bohemian alchemist Johann von Laaz supposedly described Barbara's alchemical experiments in a manuscript written about 1440, which was later lost. The doctor Benedict Nikolaus Petraeus reported about Laaz' testimony in the preface of his edition of the *Chymischen Schriften* (Chemic writings) of Basilius Valentinus. The authorship of the supposed Benedictine Basilius Valentinus was probably a hoax. One of the real authors behind that penname was the Paracelsus-fan alchemist and poet Joachim Tancke (Tancky, 1557/1559 Perleberg in Brandenburg-1609

Leipzig)¹⁶¹ who became the Leipzig professor in 1589; as the rector there he repeatedly wielded his stick. Until in 1624 he participated in the hoax Basilius Valentinus' publication of Johann Thölde of Hesse (1565–1624), a city chamberlain in Frankenhausen and co-owner of the plant used for the salt production. He published his felicitous alchemy under the fanciful name of the supposed German Benedictine monk Basilius (Basil) Valentinus.

Barbara liked Laaz (Laatz) in the first place and Laaz welcomed the opportunity to examine Barbara's alchemical knowledge. She had answered Laaz' sophisticated questions "with feminine subtlety." In front of Laaz' somewhat surprised eyes, Barbara with a powder of mercury, arsenic, and concealed ingredients, dyed her copper white and thus supposedly converted it into silver. Laaz, however, found that the product was really like silver, but the metal was not strong enough to resist the hammer. Barbara also introduced to him many similar "art pieces", including "iron ice", "copper lime" and other powders of "gold", which, however, lost its color when Barbara melted it. Laaz (Laatz), who was himself a kind of hoax, wrote that she had deceived many merchants in her times, which was not very likely because Barbara was extremely wealthy, and she really did not need that kind of additional incomes. When Laaz accused her of deception, she threatened to imprison him, but he had "come back from her headquarters with God's help" once again. Other princes of their times also dealt with alchemy, especially Johann von Brandenburg-Kulmbach, who politically promoted his alchemistic networks to smooth his good relations with the House of Brandenburg.¹⁶²

¹⁶¹ <https://www.wikidata.org/wiki/Q1613237>

<https://thesaurus.cerl.org/record/cnp01113736>

¹⁶² Ulrich Büttner, Egon Schwär: Barbara von Cilli - Empress, Femme Fatale, and Vampire, in: (ed. Ulrich Büttner, Egon Schwär), *Konstanzer Konzilgeschichte*, Constance: Stadler, 2014. 63-68; Ferguson, *Bibliotheca Chemica*, Glasgow 1906, 2: 10; Karl Christoph Schmeider, *Geschichte der Alchemie*, Halle 1832, Hamburg 1717, Katanec Sara. 2014. *The Perquisite of a Medieval Wedding: Barbara of Cilli's Acquisition of Wealth, Power, and Lands*. MA thesis, Budapest.



Figure 3-13: Barbara and her husband in the council of Constance enrolled in all the glory of the supreme rulers.

The pseudo-chemist Laaz was just one of the many visitors in Barbara's alchemical-astrological networks which were well known to the interested learned circles. Besides the erudite, the common folks also talked a lot about Barbara's occult research, which put the work of Barbara in quite a different limelight. Many legends were spread about her apparently black magic and just her highly advanced social status saved Barbara from the troubles. She might have suffered even harder than Veronika, but all those crowns on her head protected her.

Barbara was even happy enough to survive her only offspring because the poor daughter died in her early thirties in 1442. Barbara spent most of the rest of her life in Mělník, where she allegedly devoted herself to the occult sciences. She loved to inspire herself into the mystical research as she was concerned with alchemy and astrology, all of which felt deep into

the hands and minds of many of her contemporaries. This fame of Barbara went so far that later even the legends arose. In some of them she would have evaded as a vampire during the Constance Council, and still today some memories of Barbara's whereabouts tell the story that she should be feared in the Balkans as a blood sucker. The signs of her evil obituary as a "German Messalina" were promoted by Barbara's dynastically competing Hapsburgs: "She fell into such an antichrist abuse. And her body and soul would die together".¹⁶³ That was certainly a hard wish.

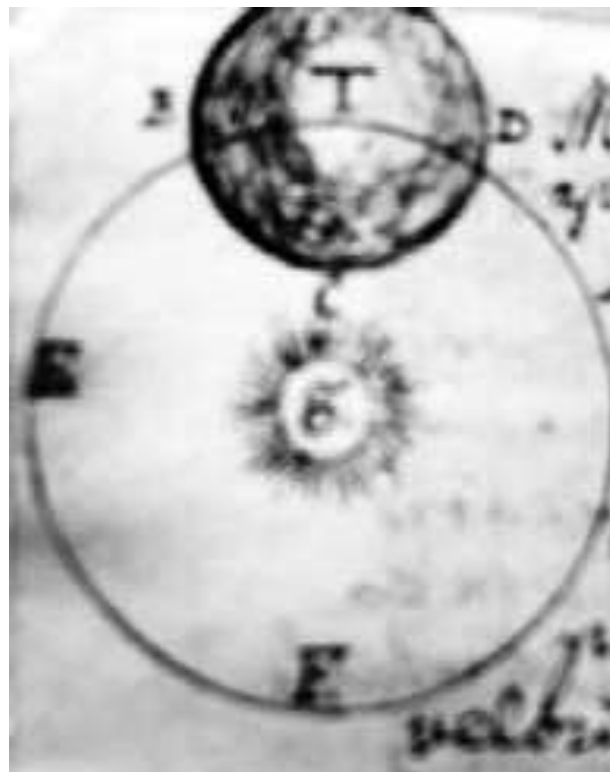

Figure 3-14: The Ljubljana based Franciscan lecturer of philosophy with physics illustrated the Copernican motion of planets in vacuum soon after the suppression of Jesuit order (Anonymous, 1774-1775, 8r; F).

Barbara spent her last years in Mělník 35 kilometers north of Prague above the huge vineyards. She was also frequently in Hradec Králové (Königrätz) a hundred kilometres to the east which was also the ordinary residence of the queens.¹⁶⁴ The aging

¹⁶³ Hartmann Schedel, 1493, *Weltchronik*.

¹⁶⁴ Paušek-Baždar 2008. Königin Barbara zu Cilli als Alchimistin in Samobor. *Godišnjak Njemačke narodnostne zajednice* 15/1: 279.

Barbara enjoyed the protection of the powerful Bohemian future king of the Utraquists moderate Hussite party named Podebradski (Jiří Poděbrad, 1420-1471). Podebradski was adopted as the executor of Barbara's rights in 1445. With George Podebradski backing her, Barbara joined the winning side of Hussite conflicts which her husband and nephew did not particularly approve. George Podebradski was a quarter of century Barbara's younger and as the real gentlemen he took care for aging Barbara.

After Barbara's long postponed death, George Podebradski got Mělník and all her cities which she received as the dowry upon her coronation as the Bohemian queen. On 11 July 1451 Barbara died in Mělník of plague that raged there more-or-less because she was approaching her sixties which was quite an old age in her times. Barbara tried to use her distilled alcoholic beverages to stop her own disease as she learned from Laaz a dozen years earlier, but her aging body was willing no more. The last notice she received was the happy one as her beloved native settlement of Celje finally received its town privileges on April 11, 1751. Barbara's brother Frederik was in charge there and he hurried to inform Barbara about that happy news. Exactly three months later Barbara's days were over, while Frederik had another three years to think about all kinds of everything. Barbara's royal body was transported to Prague with all custom ceremonies included. Her Czech friends buried her remains with great honors in the royal tomb in the chapel of St. Andrew and Silvester of St Vitus Cathedral in Hradčany in her beloved Prague, where many other European rulers were also buried. George Podebradski (Jiří Poděbrad) was crowned as the king of Bohemia after the premature deaths of Barbara's nephew Ulrich and Ulrich's protégé Barbara's only grandson Ladislaus V the Posthumous.

Barbara survived as a symbol. She was not always a good girl, but she was certainly a clever one all the times. Her research in sciences and technologies was performed in completely other ways in her space of times and social structures compared to later circumstances, which makes someone hard to judge Barbara's merit from the contemporary point or view of publish or perish.



Figure 3-15: The Ljubljana based Franciscan lecturer of philosophy with physics illustrated Ptolemy's motion of planets in vacuum soon after the suppression of Jesuit order (Anonymous, 1774-1775, 8v; F).

3.2.2 Copernicus on Vacuum

3.2.2.1 Introduction

Barbara was a pioneer of the long series of researchers of new materials connected with the lands inhabited with Slovenes. Barbara loved her new materials produced in her alchemistic lab, while she also liked astrology. It was too early for her to promote heliocentrism which gained ground with Copernicus' work a century after she passed away. A few years ago, we discovered in Ljubljana the mistakenly forgotten Copernicus work from 1566. The discovery confirms the exceptional scientific ambitions of Slovenian ancestors. What does it have to say about the beginnings of vacuum techniques in Slovenia, as Copernicus used to be the beginner of modern new science in Europe?

Copernicus died a hundred years before Torricellian experiments. So, of course, on the experimental plane, Copernicus still could not think about the vacuum technique in a modern way. By the way, he could not pass without the vacuum issue, since the later Galilean clouds began to collect over him. What was Copernicus's opinion about emptiness?



Figure 3-16: The title page of the Ljubljana edition of the second edition of Copernicus's work from 1566 in FSLJ



Figure 3-19: Frombork (Frauenburg) near the Baltic Sea in the then Prussia, today's Poland, where Copernicus died on May 24th 1543



Figure 3-17: The page of Copernicus's *De Revolutionibus* manuscript (212 sheets, with the permission of the Public Library in Krakow).



Figure 3-18: Torun (Torno, Thorn) in the then Prussia on the border with Great Poland, where Copernicus was born on 19 February 1473.

3.2.2.2 Copernic's Atoms and Vacuum between them

Copernicus' universe, or the solar system, was infinitely large in comparison with the Earth. He also considered invisible atoms that reach a noticeable size only when they are collected in large enough quantities.¹⁶⁵

Atoms of Democritus, Epicurus and Leucippus, of course, presupposed the existence of a vacuum between particles of matter. Although he did not explicitly mention the vacuum, Copernicus assumed his existence on Earth with his discussion of the atoms. He has not yet asked questions about how the planets move around the Sun without friction, although the other researchers have already written about it.

Besides the Ljubljana Jesuits, the Franciscans of Ljubljana also acquired Copernicus' book in its second edition. They also got astronomic-geographic work of Johann Schöner (1477 Karlstadt am Main-1547 Nurnberg). After Johann Schöner passed away, Gemma Frisius (1508-1555) edited his book. In Nurnberg, Rheticus' first teacher of astronomy was Schöner. Rheticus later became the only relevant student of Copernicus. Therefore, Schöner became the early reader of Copernicus' ideas which Rheticus summarized for him in *Narratio Narratio Prima*, as noted in the title of Copernicus' second edition. Schöner's book was printed nearly simultaneously with Copernicus' first edition, and the Franciscans of

¹⁶⁵ Copernicus, 1998, 58-59.

Ljubljana bound it in parchment with some additional carton coverage. The part of other book used for binding must have belonged to 9th division of Ljubljana Franciscan library and not to 10th division to which Schöner's work should be catalogued. Gemma added to Schöner's book his own unpagged work as the last third part of it in 1548 and concluded the edition with Schöner's rules for the uses of sphaera armiralis (κρικωτῆ σφαῖρα). The previous owner of the Ljubljana Franciscan book was Michaelis Khernis Gablosensis (Černe Chernis, Gablkouer, Gablkoven) who got the item from Abraham Rucly on 21. 7. 1602. Before the title page there is partly preserved bookplate dated in (15)68. The first geographical Ptolemy's part of the book had the table of geographic longitudes of cities¹⁶⁶ with descriptions of Austria, Styria, Carinthia, Hungary, but not Carniola. The author added the geography of American islands and peninsulas including the Yucatan and Jamaica,¹⁶⁷ which certainly interested the Franciscan missionaries of Ljubljana.

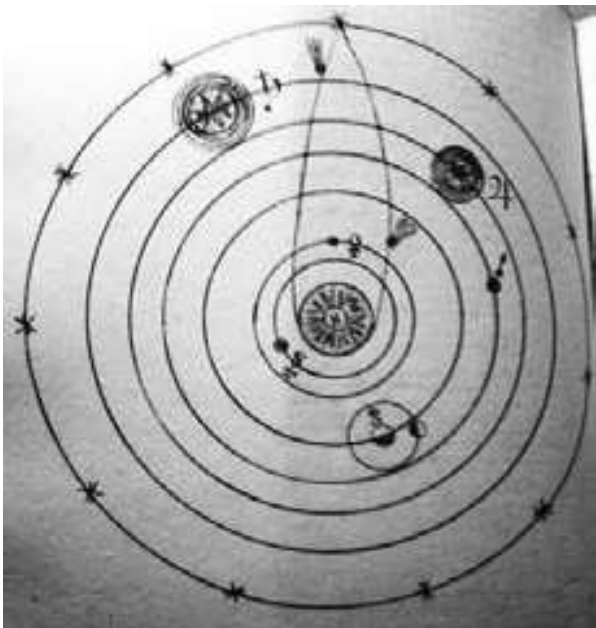

Figure 3-20: The Ljubljana based Franciscan lecturer of philosophy with physics the Bavarian Theofil Zinsmeister illustrated the Copernican motion of planets in vacuum (Zinsmeister, 1799, 2: 156; F).

Gemma wrote the introductions to the first part of the book long before their printings. The

¹⁶⁶ Schöner, Gemma, 1548, 72r-72v.

¹⁶⁷ Schöner, Gemma, 1548, 39v, 71r-71v.

introduction to the first third of a book was dated in Antwerp on 1. 10. 1530 and the introduction to the second third Schöner (not Gemma) dedicated to Johan Khreutter in Leuven in February 1514. Johan Khreutter served as a secretary of Hungarian queen Mary of Habsburg (1505 Brussels-1558 Spain), the widow of Louis II Jagiello (1506-1526 Mohács). The granddaughter of the emperor Maximilian I, queen Mary, served as the governess of the Netherlands for her brother the Emperor Karl V. Gemma dedicated to Johan Khreutter his own treatise on the astronomical rings in 1534.¹⁶⁸ Johan Khreutter was a friend of Cornelius Agrippa. The astronomical rings were an early astronomical instrument consisting of three rings, each representing the celestial equator, declination, and the meridian. It can be used as a sundial to determine time, if the approximate latitude and season is known, or to ascertain the latitude. It was a simplified, portable armillary sphere, or a more complex form of astrolabe.



Figure 3-21: The title page of the geographic-astronomic book of Gemma Frisius and Schöner in the Franciscan library of Ljubljana.

¹⁶⁸ Gemma, *Usus annuli astronomici*. In: *Petri Apiani Cosmographia* Antwerp: Aegidius Copenpius and Arnoldus Berckman, 1539, folio 2r.



Figure 3-22: The title page of Schönner's instructions for the use of armillary sphere (Sphaera Armillaris, κρικοτή σφαῖρα) in the Franciscan library of Ljubljana (Schöner, Gemma Frisius, 1548, 89r).

The second third of a book was divided into twenty paragraphs. Many funny illustrations of visually measured heights of stars or towers were added; at the end there was again the table of geographic longitudes of cities. Schönner's rules for the uses of sphaera armillaris (κρικοτή σφαῖρα) were published in 1548 with undated introductory greetings in epigram of sphaera armillaris (κρικοτή σφαῖρα). He cited Regiomontanus' opinion about the shape of meridians in Arctica. In the last part the unsigned Schönner described the types of sphaera armillaris (κρικοτή σφαῖρα) dedicated to the bishop of Bamberg named Georgio, in fact Georg Schenk von Limpurg (1470–1522) who excelled as the trusted imperial advisor of Maximilian I. Schönner tried to figure out the distances between the stars and the Sun in zenith, as well as the apparent solar and lunar heights (altitude). He used eight domus for prophecies based on Ptolemy's Almagest.¹⁶⁹

The other early owners the Copernicus' Book, the Jesuits of Ljubljana, used a lot of books of Copernicus' contemporaries who also considered vacuum. Among them was Benedetti,¹⁷⁰ a disciple of

¹⁶⁹ Schönner, Gemma, 1548, 2r, 39v, 71r-71v, 73v, 74v, 83v, 85r, 87v-88v, 94v. 103r, 104r, 112r, 114v.

¹⁷⁰ Giambattista Benedetti (Benedictus, * 1530 Venezia; † 1590 Torino).

Tartaglia.¹⁷¹ He published some evidence of Copernicus' assumptions and paved the way to Galileo's dynamics with his ideas. In 1558-1566, the Copernicus fan Benedetti was a mathematician at the court of the Duke Ottavio Farnese (1524-1586) in Parma and later at the court of the Grand Duke of Savoy in Turin. He wrote the book in the form of letters to various scholars, among others to Nuñez,¹⁷² the first professor of advanced mathematics at the University of Coimbra in Portugal.¹⁷³ Benedetti wrote about many questions, including the squaring of the circle,¹⁷⁴ or the temperature differences on the Sun¹⁷⁵ interesting in connection with the sunspots discovered later in 1610. He discussed the vacuum in the Heron vessel, the weights of air and oil.¹⁷⁶ Benedetti used the arguments of Giovanni Filippo from the 6th century to challenge Aristotle's assumption of the impossible infinite speed of missiles in a vacuum.



Figure 3-23: Cardano's siphon with submarine in the Franciscan library of Ljubljana (Cardano, 1627, 690).

This seemed to him particularly important as a continuation of Benedetti's teacher Tartaglia's

¹⁷¹ Bogoljubov, 1983, p. 39; Cantor, 1900, 2: p. 388, 565-566; Benedetti, 1599, p. 241, 241, 261. Niccolo Fontana called Tartaglia (* 1499; † 1557).

¹⁷² Pedro Nuñez (Nonius, * 1492 Alcazar del Sol; † 1577 Coimbra).

¹⁷³ Cantor, 1900, 2: 388; Benedetti, 1595, 214.

¹⁷⁴ Benedetti, 1595, 303.

¹⁷⁵ Benedetti, 1595, 358.

¹⁷⁶ Benedetti, 1595, 225-227.

research of the movement of cannon missile.¹⁷⁷ Of course, the research of the vacuum became particularly interesting after Torricelli, Guericke and Auersperg's experiments half a century after Benedetti's death.

Benedetti's letters (1599) were probably the first mathematical work procured for the Jesuit college in Ljubljana. Copernicus, Galileo, and vacuum issues were by no means foreign to Slovenian Jesuits even at the time when the discussions of these ideas were officially restricted in Catholic countries.



Figure 3-24: The first page of the list of the mathematical part of Auersperg's library that was drawn up in Ljubljana fourteen years after the participation of the Auersperg Prince at the Guericke's experiments in Regensburg. The census lists Galileo, Harsdörffer, and Kepler's books (Haus-, Hof- und Staats-archiv, Fürstlich Auerspergsches Archiv, VII Laibach, A 14/4 conv. 1 Laibach-Fürstenhof 1729-1895, Vienna, Minoritenplatz 1, Catalogus, Septima Classis sive Mathematica, 1668, 331).

In the early days Carniolans purchased the books of Tartaglia's sworn opponent Cardano.¹⁷⁸ In Copernicus' time Cardano designed procedures for production of vacuum by the condensation of steam. The Jesuit Porta¹⁷⁹ developed Cardano's ideas into his attempts to lift water in a vacuum tube, which was adopted by Edward Somerset, 2nd Marquess of Worcester (1602/1603–1667) in 1663 and finally by Boyle's assistant Denis Papin.¹⁸⁰ Porta was thinking about a vacuum in the universe, as well as on Earth, after the example of Pythagoreans and Heron's experiments in Alexandria.¹⁸¹ The inhabitants of Ljubljana had many Porta's works, and the Carniolan family Rechbach had even two different Porta's prints.

A century after the publication of Copernicus's book, Prince Auersperg¹⁸² helped Otto Guericke during their vacuum experiments in Regensburg. In any case, he already learned a lot about a vacuum as a young man in Ljubljana. He even read about vacuums in his rich library in Ljubljana in the mature years. His important basic role played in Guericke's beginning of the vacuum technique is not a complete surprise: Ljubljana of those times was one of the centers of the exchanges of ideas of modern science during the Renaissance between the Baroque Italy and the imperial humanists residing in Vienna. Among other things, Auersperg in his library in Ljubljana kept a book on hydro-technics and vacuum experiments of the Prague professor and rector Dobrzensky de Nigro Ponte¹⁸³ from a famous Prague medical family, which was strongly criticized by the nobleman Rain¹⁸⁴ from the castle Strmol by Cerklje near Kranj. Of course, today might be difficult to evaluate which side in that quarrel was then supported by the prince Auersperg, but certainly his experience with vacuum experiments influenced Dobrzensky's research.

¹⁷⁸ Girolamo Cardano (* 1500; † 1576).

¹⁷⁹ Giovanni Battista della Porta (* 1534/35; † 1615).

¹⁸⁰ Crombie, 1970, 436.

¹⁸¹ Porta, 1561, 1: 282^v, 2: 125^v, 127^f.

¹⁸² Prince Janez Vajkard Auersperg (* 11. 3. 1615 castle Žužemberk; † 13. 11. 1677 Ljubljana).

¹⁸³ Jakob Joannes Wenceslaus Dobrzensky de Nigro Ponte (Jakub Jan Vaclav (Wenčeslav) from Černeho Mostu (Schwartzbrug), * 1623; † 1697).

¹⁸⁴ Janez Friderik (Joannes Frideric) von Rain.

¹⁷⁷ Crombie, 1970, 324-325.

The first Slovenian vacuumist, Auersperg, did not only acquire the works of foreign authors in his library, which was the best private collections in the Baroque Europe at that time. In a prominent place he also had a book of Carniolan professor of mathematics Kobav.¹⁸⁵



Figure 3-26: The title page of Aleksander baron Ruessenstein's initial manuscript book on philosophical stone in the Franciscan library of Ljubljana (Ruessenstein, Drittes Buech von denen zusamm getragenen Schriften des Herren Alexis Baron Ruessenstein (von Salzburg), dated 1694 1694a, 1 (FSLJ- 29 F-56)).

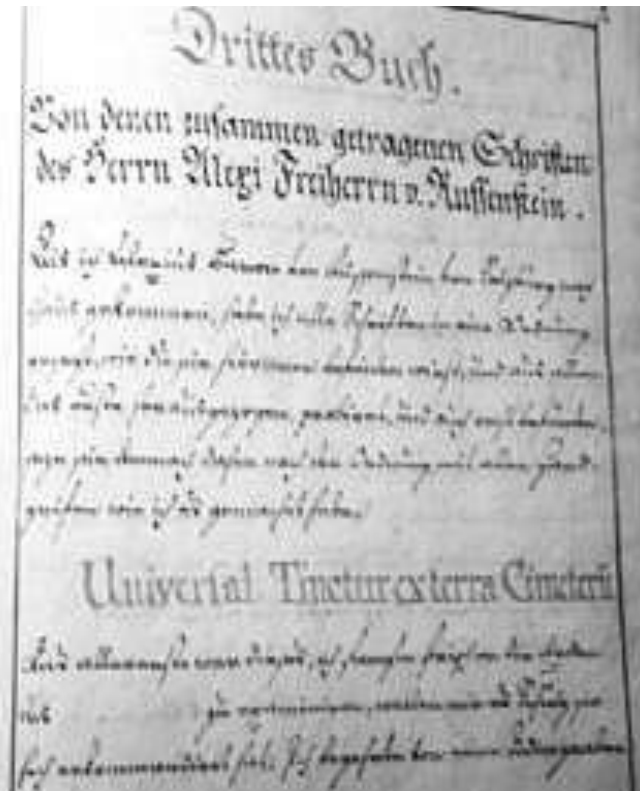

Figure 3-25: The title page of Aleksander baron Ruessenstein's clean copy of his edited manuscript book on philosophical stone in the Franciscan library of Ljubljana (Ruessenstein, 1694, 1 (FSLJ- 29 F-54)).

3.2.2.3 Conclusion

The surprising discovery of Copernicus's books in Ljubljana is reflected in a more anticipated light if we connect it with an extremely important basic role played by the first Auersperg Prince in early Guericke's vacuum experiments after the Galilean quarrels about Copernican doctrines. The findings of this kind certainly leave a new self-esteem of Slovenian vacuumists, the successors of so famous ancestors.

¹⁸⁵ Andrej Kobav (* November 1591 Cerknica; SJ 22. 10. 1610 Brno in Moravia; † 12. 2. 1654 Trst).



Figure 3-27: Koller's illustration of refraction of light at the beginning of first Stefan's lecture about the theory of light at winter semester 1863/64, read on 20 October 1863 (Koller's notes taken from J. Stefan lectures, manuscript 26).

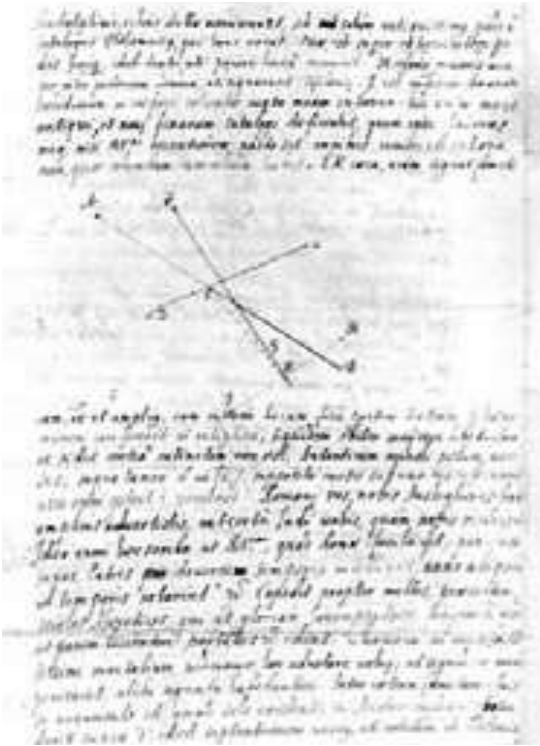

Figure 3-28: Kobav's explanation of the motion of comet in his Viennese letter mailed to Kircher (APUG, 567, folio 20v, page 2e).

3.2.3 Vacuum of Trubar's Days

3.2.3.1 Introduction

At the time of Trubar's birth, the most important Slovene professors of humanities taught in Vienna, where they occupied so many main chairs and positions as never before or after. On 14 April 1528 Primož Trubar enrolled at the University of Vienna and listened to the philosophy with physics in the classes of the most prominent Slovenian scholars, such as Styrian Andrej Perlah, while the Zasavec (born by Sava riverbanks) Matija Hvale had already died before Trubar's studies. Nevertheless, Trubar naturally read Hvale's philosophy of nature with thoughts about a vacuum, which may have been preserved in the NUK in Ljubljana right from Trubar's library. Unfortunately, several months after the arrival of Trubar, the Turks under the Suleiman the Magnificent besieged Vienna for their first time; therefore, Trubar did not finish his studies, but returned to Trieste. Similarly, most Trubar's classmates run away, so the number of students enrolled at the Viennese University from close to 700 in Trubar's boyish years fell to zero in 1532.

In Vienna, some of Trubar's colleagues studied at least occasionally, among them Adam Bohorič, who reached the first academic degree of Baccalaureate in Vienna in 1547. The accumulated thoughts about vacuum and other puzzles of the then natural science in Vienna influenced Bohorič's purchase of five hundred books, his rectorate in Ljubljana and, last but not completely least, his own writings. At least Bohorič and Trubar were among the Slovene Protestant heirs of a rich tradition of reflections on the vacuum of the Viennese professors of the Slovene genus.

The older Trubar collaborators studied in northern Italy, among them the bishop Peter Bonomo in Bologna (1487),¹⁸⁶ and Peter Pavel Vergerius the younger in Padua until 1523.¹⁸⁷ Most of Trubar's younger colleagues studied in Tübingen, including his sons, Jurij Dalmatin, Frischlin and Bohorič, since the Duke of Württemberg specifically advocated the spread of Protestantism in the Inner Austrian lands with Carniola included.



Figure 3-29: Melanchthon's foreword to Euclid in the Franciscan library of Ljubljana (Melanchthon, Euclid, Elementorum geometricum libri XV, cum expositione Theonis in priores XIII a Bartholomaeo [Zamberto], Veneto (Zamberto, Bartolomeo Zamberti * abt. 1473 Venice; † 1543), latinitate donata, Campani (Campanus da Novara) in omnes et Hysiclis, ... in duos postremos. His adjecta sunt Phaenomena, Catroptica et Optica, deinde Protheoria Marini et Data. Postremum vero Opusculum de levi et ponderoso, hactenus non visum, ejusdem auctoris [Philippus Melanchton praefatus est]. Basileae: Hervagius, 1546, (FSLJ-24 k 47)).

¹⁸⁶ Kidrič, 1925, 1: 53.

¹⁸⁷ Filipović, Rajhman, 1982, 4: 407.

3.2.3.2 Terpin's List of Upper Castle (Gornji Grad) Books

What did Trubar's think about vacuum? Trubar's authored books were extremely religiously oriented,¹⁸⁸ while several natural-science thoughts are in his letters and especially in the books of his library. Trubar repeatedly praised Luther's chief co-worker, Philip Melanchthon, whose physics with vacuum descriptions was also used in Ljubljana, while the Franciscan in their library used Melanchthon's foreword to the translation of Euclid.¹⁸⁹



Figure 3-30: Title page of Index of prohibited books of the Pope Innocent XI in the Franciscan library of Ljubljana (Innocent XI, 1726 (FSLJ)).

Melanchthon was convinced that nature at first avoids infinite quantities, while as the second nature avoids vacuum. On the third point nature does not allow several simultaneous positions of the same body contrary to Heisenberg's uncertainty principle

¹⁸⁸ Kranjc-Vrečko, 2002, 548.

¹⁸⁹ Rajhman, 1986, 28, 41; Trubar's letter to the emperor Maximilian on 2. 1. 1560; Melanchthon, Euclid, Elementorum (geometricum libri XV), interpreta Barth Zamberto Veneto, cum expositione Theonis in priores XIII a Barth (Zamberto) & Campanus da Novara & Hypsiclis, Basileae: Hervagius, 1537/1546, unpagged introduction II-VII (FSLJ-24 k 47).

published half of millennia later. On fourth point the nature refuses penetration into the substance as the Pauli's exclusion principle formulated half of millennia later, and in the ultimately fifth point the nature avoids the destruction of the substance in an early form of law of conservation of energy which was fully understood only three centuries later. Melanchthon denied the possibility of a vacuum in nature and gave an example of a water clocks where the water fills up completely any created voids. In the vacuum, movement is not possible: Melanchthon's standard scholastic responses, as well as the continuation of the chapter on thinning and condensation was purely Aristotelian, just like his description of time and infinity.¹⁹⁰



Figure 3-31: Self-explanatory illustration at the Title page of Index of prohibited books of the Pope Benedict XIV in the Franciscan library of Ljubljana. He finally lifted the sharpest ban of Copernicus' book, but he kept Trubar's works in his index (Benedict XIV, Index Librorum Prohibitorum, 1758 (FSLJ)).

¹⁹⁰ Melanchthon, 1560, 157^v, 158^r, 158^v, 160^v.



Figure 3-32: The Grammar lady as a guide leads the student through the knowledge house in the book noted in one of the oldest Slovene preserved catalogs of books of Terpin (Reisch, 1508).

After the Tridentine council, Trubar's writings went to the index of prohibited books, where Frischlin's collected works joined them in 1603.¹⁹¹ The lists of books of Trubar and his colleagues' collections were not entirely preserved, but after the confiscations they were mostly brought to the Gornji grad (Upper castle) Diocesan Library in southern part of Styria. Some might have been burned, but those acts are not very probable considering the huge cost of books in those days. Many works from the libraries of Carniolan Protestants were transferred to Upper Castle, including the legacy of the Protestant school teachers of Ljubljana Lenart Budina, his son Samuel Budina, and 274 Primož Trubar's books inherited by his son Felician Trubar. After selling his Ljubljana house in 1569, P. Trubar presented a box with books to the Carniolan "Land and Church"¹⁹² as the basis for a library of Estates General or even the first public library on Slovenian soil,¹⁹³ where many opinions about the vacuum could be read. In 1604,

¹⁹¹ Benedict XIV, 1758, 117, 296; Pius VI, 1726, 116, 296.

¹⁹² Rajhman, 1982, 4: 210.

¹⁹³ Simoniti, 1974, 25; AS, Estates general archive, Fascicle 54/7, volume 2, pages 403-415.

the provincial Estates general attempted to smuggle their books hidden in the barrels to Swabia, but their cargo was seized and taken to the Upper Castle (Gornji Grad) of Styria.



Figure 3-33: Terpin's list of philosophical books with descriptions of vacuum - beginning (Terpin, 1655, 15r).

Table 3-1: Terpin's (1655) list of Upper Castle books arranged by units¹⁹⁴ with vacuum descriptions compared to the thirteen years later Schönleben's¹⁹⁵ list of the books of the provincial Governor general count Volf Engelbert Auersperg. Schönleben entered in his catalog three times more units than Terpin.

Terpin's library section, folios	Number of titles in Terpin's list	Number of titles in Schönleben's list
Philosophy of Physics, 15r-16r	55	85
Medicine, 16v-17r	19	92
General History, 20r-21v	99	661
Total number of titles	994	3257

¹⁹⁴ Simoniti, 1974, 17-18.

¹⁹⁵ HHSa, FAA, 337-392.



Figure 3-34: Terpin's list of philosophical books with vacuum descriptions - end (Terpin, 1655, 15v, 16r).

Table 3-2: Terpin's list of books with vacuum descriptions

Author	Title	Folio in catalogue \ Year and Place
Platon	Opera Platonis	15r
Palamedes	Tabula seu index In opera Arlis	15r
Johannes Versor	Questionis in lib: phys.	15r 1486. Cologne (2 copies)
Boethius, Anitius Manila Severin	De consolata philosophiae	manuscript 15r
Wildenberg, Heronymus	Totus philosophiae humanae	15v 1571. Basel: Oporniana
Sunczer, Friderici	In octo libros physicorum Aristotelis	15v 1500. Venice: Jacobus Pentius

Scarlichi, Rajnald	manu scripta philosophia	15v 1606-1608. Graz
Reisch, Gregorius	Margarita philosophica	16r 1508. Strasbourg: Joannes Grüninger
Aristotel; Christiani, David	<i>Tractatus physico-astronomico-historicus</i>	16r 1653. Giessa: Chemlin
Aristotle	Physica libri	16r
Heingarten; Schleusingers	Tractatus de cometis materia	16r 1474. Venetii: Aurl
Jesuits from Coimbra	Octo lib. Phys.	16r 1606. Venetiis or 1609. Coloniae
Jesuits from Coimbra	In 4 libros de Coelo	16r
Toledi, Francisco (Toledo)	In Octo Libros (Aristotle) Physica	16r 1600/1617. Venice: Iuntas / Bertan
Ziegler, Jakob	Astronomia Plinis	16r, 21v 1531. Basel: Henric Petri (2 copies)
Massari, Francesco	Pliny. In nonum Plinii de naturali	16r 1537/1538. Basel: Froben (T).
Pliny the elder, Gaius Cecilius	Historia naturalis	(2 copies) 16v, 17r
Jordan, Gregor	theatri (Theatre) coeli et terrae	21v 1591. Cologne (2 copies)
Bordini, Fran	Quas et resp. Matematica	21v 1573. Bologna: Alexander Benati
Padovani, Giovanni	Viridarium Mathematicorum	21v 1563. Venice: Bologna Zalter

Half of a century later, the Diocesan Vicar Terpin in Upper Castle (Gornji Grad) catalogued the former books of the director of the Protestant school Lenart Budina, including his copy of natural science of Gregorius Reisch, bound in wooden covers.¹⁹⁶

¹⁹⁶ Terpin, 1655, 16^r; Simoniti, 1974, 31.

Reisch earned his bread as the confessor of Emperor Maximilian I and the Prior to Charterhouse of St. John the Baptist near Freiburg im Breisgau. He dealt with arithmetic, music, architecture, perspective and astronomy with excellent drawings under Dürer's influence. He wrote about the vacuum, especially when describing the universe. His first illustration was a sketch of the human eye, and under the heading *Typus grammatio*, he painted Mrs. Grammar, who leads the student along the path of knowledge through a five-story house. On the third floor, the lady logic was waiting, and on the fourth there was the lady physics with the theories of vacuum and moral teachings.¹⁹⁷

3.2.3.3 Hvale

The most important Slovenian thinker about the vacuum of Trubar's days was Hvale from the vicinity of Litija. Hvale's *Philosophy of Nature* (1513) was also among the southern Styria Gornji grad (castle) books of the Bishops of Ljubljana. It was catalogued by Terpin. Hvale's book was the oldest printed vacuum reading published by naturalists and philosophers of Slovenian descent.

At least in 1502, Hvale began to compose his only publication, when he was a magister, a treasurer, head of the Faculty of Philosophy and head of one of the main student dormitories in Vienna. He was praised as the dean of the Faculty of Philosophy elected for a half-year time on 12 April 1510.¹⁹⁸ He overhauled the nominalism that had been ruling at the University of Vienna since its foundation in 1365. At the same time, he defended humanism, which was supposed to attract students again to Vienna once they had begun to prefer Krakow and other universities, since even Copernicus studied in Krakow and not in Vienna. In 1492-1502, the Slovene astronomer Perger led the fight for humanism in Vienna as the author of the first Slovene grammar,¹⁹⁹ and continued to praise Hvale as the most prominent scientist-philosopher of humanism with its beginnings in the newly shaped ideas about the vacuum.

On 10 January 1512, Hvale addressed his introduction of the unpaginated book to his Carniolan colleague, the Radovljica native Pavel Obersteiner, the Viennese Master of Philosophy, who reached his noble status in that same year. In 1513, Emperor Maximilian I ordered a dictionary of the Slovene language to his counselor and secretary Obersteiner, who mastered then highly esteemed art of the secret encrypted writings. Obersteiner became a provost in cathedral, and between 1516 and 1544 Chancellor of the University of Vienna as an opponent of the Nuremberg Lutherans.

A Swiss doctor and Mayor of Gallen, the later Protestant Joachim Vadian, coined the introductory epigram for Hvale,²⁰⁰ which proves Hvale's involvement in Viennese humanistic circles. Hvale's pupil and then co-worker Vadian lectured on humanities in the years 1516-1518. Along with Tannstetter and other educators, he was a member of the Viennese *Sodalitas litteraria Danubiana*, and thus operated under the same humanistic patterns as the author of book about geometry in Terpin's library named Johann Vögelin.

Hvale designed his booklet as comments on *Parvulus philosophiae naturalis*, which were used in Vienna to achieve academic grade of Bachelor of Philosophy with Natural Sciences included. Hvale and his collaborators have already devoted more time to their studying of natural sciences than to other renowned works. Hvale divided his work into three tracts, each with more than twenty lessons. He opposed Averroes, much like the French humanist Fabri Stapulensis (Jacques Lefevre, 1450? Étampes in Picardy-1536), who was greatly appreciated by Hvale.²⁰¹ Hvale on the other hand used quite a lot of Arabic literature. He agreed with Occam's (Ockham) theory of impetus as it was expanded by the nominalist Buridan, focusing primarily on the natural sciences of physiology, biology and medicine. Buridan was a rector of the University of Paris in 1327, and he was a canon in Arras in 1342. He denied Aristotle's claim that after the initial shock (impetus), further movement is enabled by the surrounding medium. According to Buridan, an impetus is enough, which he described as something

¹⁹⁷ Ahačič, 2007, 70.

¹⁹⁸ Sodnik-Zupanec, 1975, 242, 244-245, 256, 259; Uršič, 1975, 89.

¹⁹⁹ Ahačič, 2007, 90.

²⁰⁰ Uršič, 1975, 89-90; SBL, 4: 80, Sodnik-Zupanec, 1975, 164, 253, 262, 269, 294.

²⁰¹ Sodnik-Zupanec, 1975, 272, 277, 260, 302.

like the modern energy. The medium was not necessary for him, especially not for the movement in the universe, which he filled with the vacuum without shouting about it from the rooftops. He thus established the principle of inertia from the first Newtonian law, and even indicated the later concepts. However, for a long time Galileo used the word "impeto" or mobility both for the speed that the body acquired at a given time, and for the distance traveled on differently inclined planes within a given interval. Despite his enthusiasm over Buridan, Hvale did not fully accept his approval of a vacuum, which was rarely at that time anyway. Since its founding (1365), the University of Vienna has supported the nominalism of Buridan and Franciscan Ockham, a physicist known for his "Ockham's Razor." The opposite direction of the "realists" of Albert the Great and his student Tomas Aquinas, who was heavily represented in Terpin's catalog of books, allowed the vacuum to be an option in principle because they did not equate it with nothing.



Figure 3-35: The head in the book of Hvale.

Hvale decorated his twelfth lesson of the first part with a picture of a bust of a man. Hvale focused on the individual parts of the skull and the esophagus, drawn as the visible part outside of the bust of a body. There, he painted a symbolic image of a human head with letters as signs of individual parts of the eye.²⁰² The problem of space, vacuum, and

²⁰² Sodnik-Zupanec, 1975, 281, 283, 288, 291, 302; Pintar, 1949, 53; Hvale, 1513, 1: lessons 12-17.

place was solved by Hvale's brief explanation of Aristotelian definitions of Albert the Great (Albertus Magnus, 1200-1280), whose books Terpin also catalogued. Despite of the otherwise modern humanistic approaches, Hvale accepted the scholastic Aristotle's space as a determinant of substance. This meant there was no room without substance. That is why Hvale rejected the existence of a vacuum three times: there is no empty space outside the world (of the Earth), it is not natural because of the horror vacui, nor is the vacuum in the material content of the bodies, such as in supposed pores.²⁰³ The first claim that denied the vacuum in the universe was particularly questionable and many doubted it because of the apparently unimpeded movement of celestial bodies.

In the first lesson of the second part, Hvale described four ancient elements and sketched their connections with four human temperaments, four feelings, and the like.²⁰⁴ The number four seemed to be something special to the humanist Hvale. In the sixth lesson of the second part, he described the dilution and condensation. The thinning was, of course, a way to a vacuum, which, however, was not entirely up to Hvale.

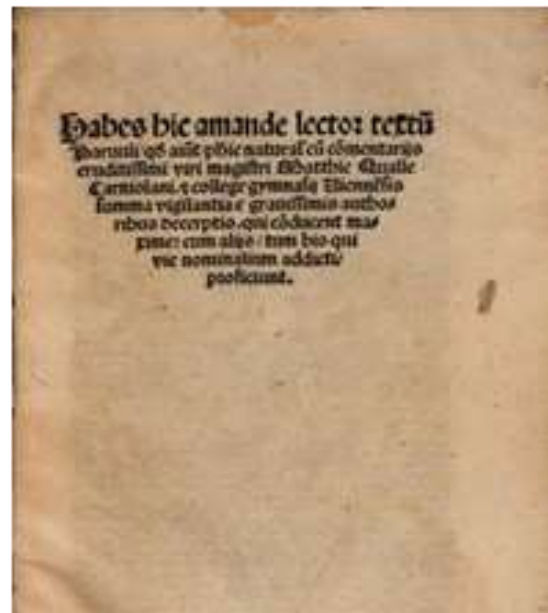

Figure 3-36: The page from Hvale's book.

²⁰³ Sodnik-Zupanec, 1975, 288-289; Hvale, 1513, 1: lessons 17-18.

²⁰⁴ Sodnik-Zupanec, 1975, 302; Pintar, 1949, 53; Hvale, 1513, 2: lesson 1.

Besides Hvale, many other Slovene scholars taught in Vienna of Trubar's days. In 1464, at the University of Vienna as a magister of philosophical sciences, the Styrian Perger lectured on Euclid's geometry, optics and mathematics with astronomy, in which he interfered with vacuum issues. In the spring semester 1470/71 he was dean of the Viennese Faculty of Philosophy, and he was the rector of the entire university in winter semester.

In 1492 the Emperor Friderik III appointed Perger as his attorney at the University of Vienna; therefore, after Friderik's death in 1493, he had a magnificent speech as Chancellor of the new Emperor Maximilian I, who soon proved his support for the scientists of Perger's kinds. Up to 13. 10. 1500, Bernhard Perger kept his super-intendant's job until he was certainly sick. Styrian Perlah from the western edge of Slovenske Gorice²⁰⁵ may not personally know his somewhat eastern compatriot Perger, but with their influences they almost followed each other at the University of Vienna and at the court of Emperor Maximilian I. Three years after Trubar's birth, in 1511, Perlah, entered the Viennese philosophical Faculty and after four years he got his title of Master under the influence of his compatriot Matija Hvale. Already as a student, Perlah began to copy and arrange foreign works that he mostly devoted to his patron, the Bishop of Vienna Jurij Sladkonja. Sladkonja was born in Ljubljana, which made him especially close to the great Styrian Perger. In the year before his death in the spring of 1522, Sladkonja allowed the Viennese St. Stefan preachers to advocate the new Reformation concepts,²⁰⁶ which the other authorities soon canceled.

Perlah became a professor of medicine after his doctorate at the Viennese Faculty of Medicine in 1530. He made an analogue computer called *Astrolabium Arithmeticum*. His invention of Ptolemean Organum gave a good enough picture for observing of Mercury, which was only rarely possible before the invention of the telescope. The

Latin translation of Perlah's German ephemeris for 1531, issued in 1530 in Vienna, was provided by Perlah's pupil, the Bela Krajina native Kukec. In 1535 he was a professor of mathematics and a procurator of students of Hungarian nationality at the University of Vienna, and in 1539 he became dean of the Viennese Faculty of Philosophy. Thus, the Slovenes Perlah and Kukec were the deans simultaneously in two of the four faculties of the Viennese University. Dr. Jakob Strauss continued with Perger's and Perlah's tradition of editing calendars. Jakob Strauss began his education in Budina's private school in Ljubljana. From 1552 to 1556, Strauss studied Philosophy at the Viennese University until his master's degree. In 1560 he completed his studies with answers to 144 questions, which also touched on the existence of a vacuum. He then went to the University of Padua before the Istrian Santorio and received a doctorate in medicine in 1565. In 1571 he became a doctor in Celje, and he occasionally treated his patients in Ptuj and Radgona. Trubar and Kepler as regional physicist and professor in Graz continued the tradition of publishing profitable calendars and prophecies in those areas after Perlah. This type of money was not provided solely with the support of a few superstitious rulers and noblemen. From Perger onwards, the cheap calendars were published even for a simple people, which was, of course, a great business.

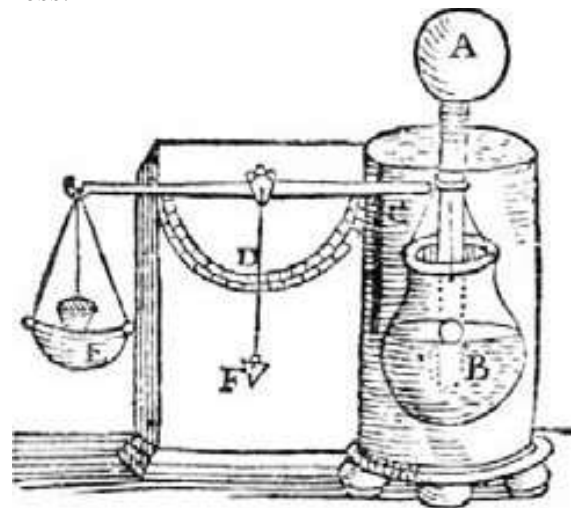

Figure 3-37: A sketch of air weighing in Harsdörffer's book kept in Volf's Library. The procedure was first performed by Koper native Santorio Santorio (Harsdörffer, 1651, 2: 365).

²⁰⁵ There are some doubts about Perger's Slavic background which relies only on scolding of Conrad Celtis (Celtis, 1459-1508) and are therefore doubted by Daniel Luger: *Humanismus und humanistische Schrift*, 2014, p. 200; *Humanismus und humanistische Schrift in der Kanzlei Kaiser Friedrichs III (1440-1493)* (MIÖG-Ergbd. 60, Wien 2016).

²⁰⁶ Belii, 1971, 43, 46, 48.

3.2.3.4 The Physician Santorio

Besides Vienna, Padua was also an important center of scholars of the Slovene genus. Many of the then educators and erudite were physicians, including Piran native Protestant Janez Krstnik Goineo and Koper native Ivan Bratti. Bratti was born in Koper according to his own narration in his main work, the *Debate on New and Old Medicine*. Bratti's contemporary from Koper was a physician and doctor Santorio, the son of the Friuli native nobleman and the noblewoman of Koper. After his initial schools in Koper and Venice, he completed his studies in Padua in 1582, and then he practiced at the Polish royal court, where the Capuchin Valeriano Magni independently carried out his own Torricellian experiment in Warsaw half a century later in 1646. The atmosphere at the Polish court was therefore favorable to vacuum experiments already at the time when Santorio first weighed the air to prove the air pressure. With this, he indirectly confirmed the possibility of a vacuum, which was later repeated by Otto Guericke with the help of the Prince of Ljubljana Janez Vajkard Auersperg. Between 1587-1599 Santorio became a doctor in Karlovac, which had just been built between 1578-1583. Santorio served the Croatian counts Krsto, Juraj and Nikola Zrinski. He then cured the illnesses in Venice as a member of the Galilean networks.

Between 1611-1624, Santorio was teaching medicine in Padua in accordance with his two six-year contracts instead of three-years-old Galileo, who went to Florentine court. After his retirement (1624), Santorio lived in Venice. In the commentary of the works of Arabic doctor Avicenna, Santorio immediately added the scale to Galileo's thermometer for medical measurements right after the start of his Paduan lectures.²⁰⁷ In 1634, the third reprint of Santorio's medical book *De Statica Medicina* was published.²⁰⁸ It was offered for sale by Mayr in Ljubljana in 1678.²⁰⁹ With medical statics in the form of aphorisms, Santorio introduced a research of metabolism and other experiments in biological sciences. Santorio invented scales on a table to measure his own weight during his eating and drinking. Thus, he has proven a high proportion

of secretion of matter through the human skin, which was unmeasurable by itself in those times. He determined the pressure and compiled a pulse gauge with a Galilean pendulum. His explanation of metabolism is often mentioned together with discovery of the blood circulation of his seventeen years younger Englishman Harvey, who also studied in Padua. Santorio's collected works (*Opera omnia*) were printed post-mortem in 1660.²¹⁰

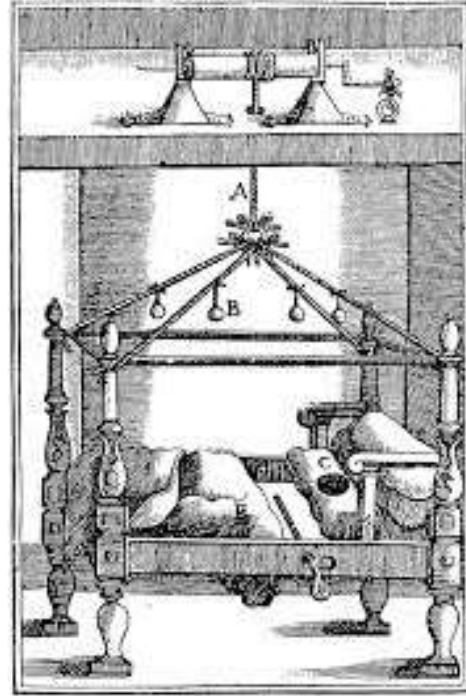

Figure 3-38: This was how Koper native Santorio weighed himself after an abundant meal to confirm the presumption of the passing of matter through the skin.

3.2.3.5 Frischlin's Vacuum in Siphons beneath Lake Cerknica

At the end of the Santorio's era, Frischlin became the first Ljubljana scientist of European reputation. He did not spend much more than two years in Ljubljana by Trubar's recommendation. In any case he placed Ljubljana on the map of scholars of the world.

Frischlin matriculated at the University of Tübingen on 12 November 1562, a year after Primož Trubar's

²⁰⁷ Santorio, 1614; Crombie, 1970, 405, 433.

²⁰⁸ Dadić, 1994, 12, 237.

²⁰⁹ Mayr, 1678, 60.

²¹⁰ Dadić, 1994, 12, 237.

relocation to nearby Urach,²¹¹ where Frischlin later ended his pursuits very sadly. In 1571, the Tübingen University was shut down due to the plague as Trubar²¹² reported to the residents of Ljubljana. For seven years, Frischlin led the philosophical discussions of the future baccalaureates, which usually lasted for three hours. He even compiled an encyclopedia of physics, morality, astronomy, logic, and rhetoric for baccalaureates, as reported to the Senate of the University. In the autumn of 1574, Frischlin publicly questioned thirty-eight candidates; among them were three candidates for the degrees of baccalaureates. He asked questions about seven free arts, as usual.²¹³ He began with arithmetic, followed by music, geometry, Sun with the Moon, astronomy, problems of vision and light, and smelling with fragrances, as the last among human senses.²¹⁴ Vacuum-related questions were placed mainly in the second half of the defense. The milieu of Tübingen, as one of the leading Protestant universities, formulated the opinions about the vacuum of Frischlin, Kepler, as well as Trubar and almost all prominent Protestants in Ljubljana of those times.



Figure 3-39: Frischlin's portrait.

The first sight of the magnificent supernova was observed on 5 November 1572. The formidable spectacle caused great excitement in Europe. A powerful shining star, which suddenly emerged in the supposed vacuum of the universe, has sparked many guesses. Of course, Frischlin also did not forget to put his erudition on stage, and he immediately published his 831 verses in the following year (1573); he wrote that poem in November 1572. He addressed it to Wilhelm's brother, the Prince Friederich Württemberg, and published it together with the accompanying letter and Maestlin's observations. The later Kepler's teacher Maestlin was right then the second professor of mathematics in Tübingen, and with his observational astronomy, he complemented Frischlin's more philosophical approach. Obviously, at that time Frischlin and Maestlin were still in good relations.

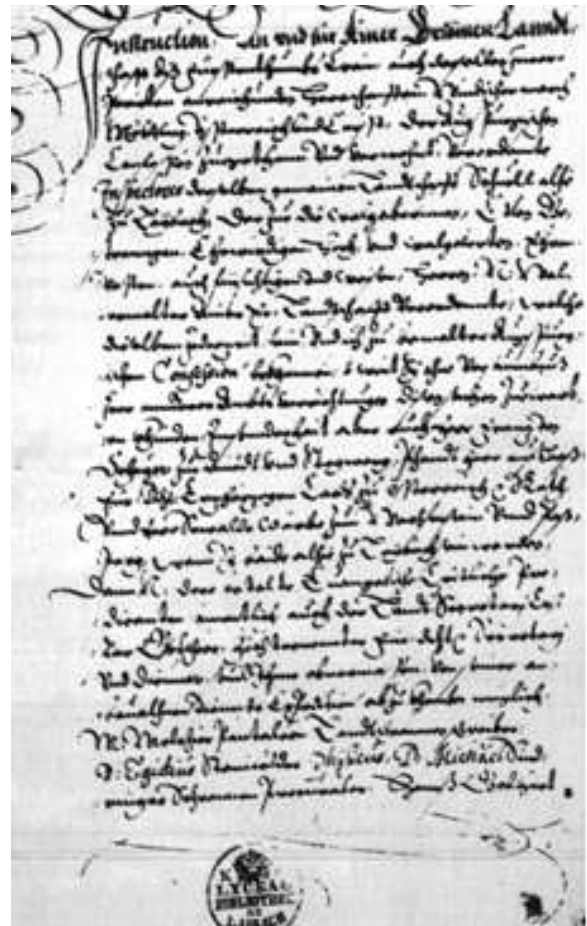

Figure 3-40: Frischlin's students of the fifth and fourth year in Ljubljana in 1583, where they also heard much about vacuum (ARS, Regional Estates General I, fasc. 98).

²¹¹ Rajhman, 1982, SBL, 4: 208.

²¹² Rupel, 1966, 302.

²¹³ Frischlin, 1598, 169-252.

²¹⁴ Frischlin, 1598, 207, 210, 211, 213, 219, 224.

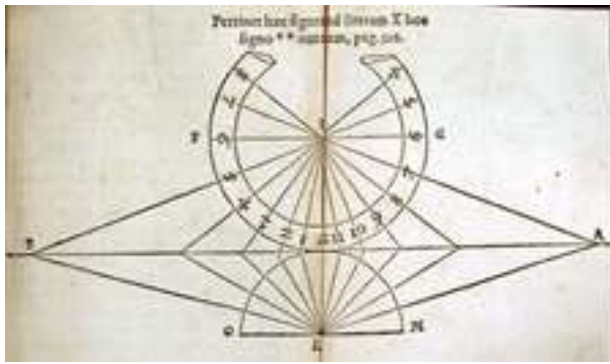

Figure 3-41: Frischlin's sketch of the zodiac when interpreting the variable speed of the Sun in a vacuum of space (Frischlin, 1586, 237)

The Carniolans also participated in the Württemberg debates about the supernova, as Primož Trubar preached for a while near Tübingen in Urach, and his patron the baron Ivan Ungnad was leading a print shop there until his death. On March 1, 1583, Frischlin wrote to Trubar in Derendingen. A few weeks later, on 3 April 1582, Dr. Jakob Andreae in Tübingen and Primož Trubar in Derendingen were searching for the successor of retired Ljubljana school rector Adam Bohorič. In June 1582, the Duke allowed Frischlin to accept the position of the Ljubljana Rector.²¹⁵

On 24 June 1582, Frischlin sailed on the Danube and Mura river through Vienna and Graz, as Frischlin traveled to Ljubljana. In June, he arrived without a family and took over the position of the rector of the school. In his Ljubljana era, Frischlin published two Latin textbooks in Venice, but he was not allowed to use them in his class. Since he published the book without the permission of Carniolan provincial Estates General, he was questioned about his motives. This was another Frischlin's displeasure while his wife was constantly complaining about her Ljubljana whereabouts. He had resigned, which proved to be a grave mistake.

Frischlin has certainly found many educated men in Ljubljana. In Ljubljana, the scientific thought was supported by the Ljubljana printer Mandelc together with the astronomer-doctor Strauss. On March 1, 1583, Frischlin wrote against the Duke of Wirtemberg and even against Primož Trubar.

Frischlin had always his conflicts with the Carniolan school inspector, the head of the Carniolan schools Juraj Dalmatin, although he supported the printing of Dalmatin's translation of the Bible upon his arrival in Ljubljana. In 1586, Primož Trubar was buried by Frischlin's opponent the chancellor and the city provost J. Andreae in Derendingen. The tombstone in the verses, which we read today in the Church in Derendingen, was compiled in Greek and Latin by Martin Crusius, who was the worst enemy of Frischlin.

Frischlin was sufficiently educated to understand the working of underground pipes in a perforated earth through which the water penetrated the Lake of Cerknica to drain from the dried bottom later. Thus, he was among the first to investigate Lake Cerknica and vacuum was involved in his description. He published a Latin-written poem about Cerknica Lake, which was reprinted by Valvasor. Anton Urbas partly translated it into German language three centuries later. Valvasor devoted to Frischlin a whole chapter of eight pages, of course,²¹⁶ with a special emphasis on his Ljubljana period. Frischlin personally looked at Lake Cerknica at least in winter and witnessed successful fishing or even ducks that were supposedly driven by winter torrents. Even more important was Frischlin's idea of underground siphons (siphonibus), which also became part of Valvasor's description.²¹⁷ Of course, Frischlin was the best Latin poet of his time. The term siphonibus could also be used in the sense of a waterjet or tube, and not only in the modern sense of the siphon that presupposes an intermediate vacuum. Frischlin might have used Žiga Herberstein's earlier description of Cerknica Lake. Valvasor's Latin language ability was much weaker and did not go beyond the high school level, so that he was probably unaware of all aspects of Frischlin's Latin poem. Frischlin's siphon theory influenced Edward Brown in 1669, who also wrote about hidden collecting lakes in Javorniki, about siphons under the visible Cerknica lake and the alleged underground lake. Similarly, Valvasor and Steinberg conceived the infinite sequence of siphons under Javornik. Only Gruber successfully criticized that siphon theory. Gruber did not accept Steinberg's description of Cerknica Lake as a system of interconnected

²¹⁵ Röckelein, Bumiller, 1990, 136.

²¹⁶ Valvasor, 1971 *Die Ehre*, 2 (7): 450, 445-452..

²¹⁷ Valvasor, 1977, 108.

siphons. Gruber was one of the pioneers in the description of Cerknica Lake and Planinsko polje as he knew that in the riverbed and lakes there is a balance between the flow of precipitation from the atmosphere and the runoff of the river towards the sea.

Frischlin wrote his astronomy in the form of questions and answers, like Kepler did later in his *Epitome astronomia Copernicana*, which was an interesting pedagogic approach. The Protestant Frischlin unanimously bravely supported the papal calendar reform in Ljubljana, but, of course, he had the support of the ruler in Graz. The Habsburg monarchy adopted the Gregorian calendar in 1584. Later, the Gregorian calendar was also supported by the Protestant Kepler, which was one of the reasons why he was not able to get a job in Tübingen.

Frischlin described the similarity between humans and planets and separated observational astronomy from astrology. He was interested in the color of the supernova fire, which, despite Maestlin's interpretation, Frischlin still identified with comets.²¹⁸ Frischlin certainly respectfully noted Copernicus's ideas about the motion of the sky. In his explanations of the heat of the Sun, Frischlin quoted the alchemical work of the Twelve Keys, published by the alleged German Benedictine Monk Basilius Valentinus. Basilius's book was even used by Newton. According to Basilius, Frischlin summed up the correct claim that the heat of the Sun promotes growth on Earth, but it does not cause it. Frischlin read the records of Menelus of Alexandria about the movement of stars and a Muslim researcher from the 9th century Albatagnus (Albatagnus) with the Arabic name Abu Abdullah Muhammad Ibn Jabir ibn Sinan al-Battani-Harrani. Frischlin accepted Pliny's and Ptolemy's opinion about the circulation of Venus and Mercury around earth beneath the sun in contrast to Plato or Aristotle. Frischlin based his opinions about the moving of planets through a vacuum mostly on Purbach's Viennese book on the motion of the eight spheres,²¹⁹ and thus approached Hvale's Viennese conception of space and vacuum. Frischlin supported

²¹⁸ Weichenhan, 2004, 532-536; Frischlin, 1586, 4 (verses 97-100, 105-110), 8.

²¹⁹ Methuen, 1998, 119; Frischlin, 1586, 6, 33, 50, 181, 221, 222, 231.

Aristotle's philosophy of nature and did not recognize the vacuum, just like Hvale.

A quarter of a century after listening to Frischlin's Tübingen astronomical lectures, Kepler's teacher Maestlin, now an already famous astronomer, rejected Frischlin's astronomy (1586) in his report to the Tübingen University. His former professor Frischlin utterly poorly mastered astronomical and mathematical terms, as Maestlin noted in his letter handed over to the duke on 18. 1. 1586. A few months before Trubar's death in nearby Derendingen, Maestlin found a mathematical error in Frischlin's data, and he even quoted the Bible in proof of Frischlin's misconceptions about the appearance of the Sun and Moon.²²⁰

Maestlin did not like Frischlin's rejection of astrology and "poetic" doubt about the use of mathematics in astronomy. Above all, Maestlin did not approve Frischlin's reception of the Gregorian Papal calendar because Maestlin was the greatest critic of Papal reform. The Copernican fan Maestlin refused Frischlin's sharp criticism of Copernicus, which was not insignificant in Maestlin's eyes. Like his student Kepler, Maestlin saw in astrology, among other things, a natural source of earnings for professional astronomers, which he was not willing to abandon. So, Maestlin critique of Frischlin had more economic than scientific background.

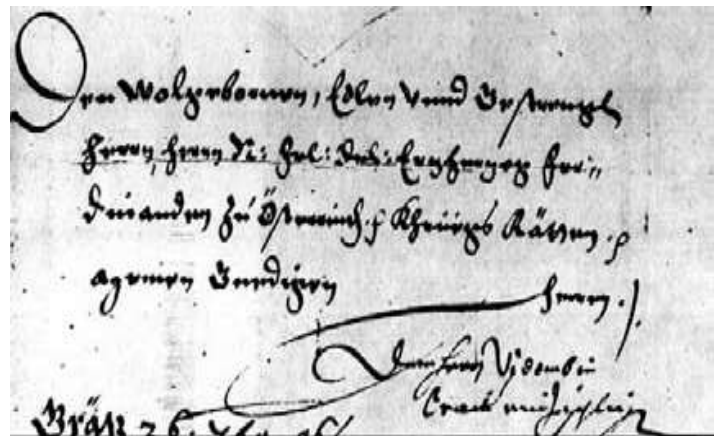

Figure 3-42: The Ljubljana Fireball of 1596: the cover of the ruler's decree signed in then capital, Graz, on October 7, 1596 (SI_AS, Archives of Slovenia, Vicedom's archive, box 181, fasc. I / 102, IX-2, p. 4).

²²⁰ Maestlin, 1584, fol 10^r; Methuen, 1998, 129.

A member of the Academy of the United (St. Dizma) and Terpin's successor in the position of a diocese vicar, Carl Peer, kept Frischlin's Astronomy (1586) in solid leather coverings among Peer's 1022 works bind in 2019 volumes. Peer's copy of Frischlin's work is in NUK today, while the Semeniška (Seminary) Library have inherited several other treasures from Peer's collection.

3.2.3.6 Ljubljana Design of Fireball Resembling later Steam Engines

In Trubar's days in Ljubljana, the experts did not only witness an advanced theory, but also a bunch of practical inventions, the ancestors of steam engines. Shortly after Trubar's death, on 20 September 1596 Gregor Corissa from Ljubljana sent to the emperor Ferdinand and to a viceroy in Ljubljana an extraordinary letter on three pages about the invention of fireball of Joachim Turekh, who was probably also a citizen of Ljubljana.²²¹ At the same time, he addressed the letter to the four members of the chamber. The fireball should be used at 100 miles of distance and could be even set to start and operate after 24 hours; a kind of medieval timebomb. It produced a powerful fire. Turekh used Heron's ancient findings about vacuum, air pressure and steam engines. He handed over his invention to Corissa, who wanted to show Turekh's ideas to the archduke Ferdinand II. On 26 September 1596 he sent another letter, and the archduke answered him on 7 October 1596.



Figure 3-43: Kepler's memorial plaque at the Paradeishof number 1 building in Graz, where he taught (Photo: Bruno Besser, 2005).

3.2.3.7 Kepler in Prekmurje

Frischlin's younger Tübingen colleague Kepler as a Styrian provincial mathematician left a deep trace in the development of science in today's Styria. How deep? What was his influence on thinking about the vacuum in Inner Austria?

The most important Estates General's Protestant school (Stiftsschule) in the Habsburg hereditary countries worked in Graz from 1 June 1574 to 1602. Kepler taught there from 11 April 1594 to 28 September 1597. Until 1600, he continued with lessons, practically without students.²²² After the reformed school order of 1594, they taught mathematics and physics in the last fourth public class (quarta classis, quae publica dicta) in Graz and Ljubljana.²²³

On 11th/21st April 1594, Kepler came to Graz, although he had not finished his studies in Tübingen, which he should have done in the summer of 1594. Kepler's friend, the Slovenian Protestant Sigmund Friderik Herberstein, was by the funny old fashion in charge of "chopping meat at the court". In September 1595, Kepler mildly mocked about this Herberstein's lucrative job which used to nurse such funny medieval obsolete name. Herberstein was born on Šahenturn in today's Gornja Radgona on Prešerenova Street no. 1 shortly after the first edition of Copernicus' book. Herberstein was among the first readers of Kepler's *Mystery* together with Maestlin, professors and students of Tübingen University, Styrian nobles, Kepler supporters, Galileo and Tycho Brahe.²²⁴ Kepler wrote the *Mystery* from July 1595 to January 1596 while he was consulting with Maestlin. In February 1596, Kepler went to publish his *Mysteries* in Tübingen, and at the same time he prepared his wedding with a twenty-year-old Protestant Barbara Müller from Graz, a double widow with one daughter. As a professional astronomer Kepler first published in his *Mysteries* a convincing geometric interpretation of the Copernican theory of motion of celestial bodies in a vacuum, to which just this Keplerian work gave the right swing; so far, only a dozen astronomers

²²² Belii, 1971, 30, 260-261.

²²³ Vidmar, 2000, 10, 24.

²²⁴ Kepler, 1984, 240, 242, XXIV.

²²¹ SI_AS, Vicedom's (Viceroy's) archive, box 181, fasc. I/102, IX-2.

supported it. Kepler had corresponded with Galileo, even if he did not agree with all Galileo's descriptions of vacuum.



Figure 3-44: Title page of Kepler's *Mysterium Cosmographicum* from the year 1596 issued by the same Tübingen printer Georg Gruppenbach who released Trubar's translation in next year.

Trubar and Kepler often met as they had the same publisher Georgius Gruppenbachius in Tubingen. Kepler inserted several geometric images into the text of the Mystery. He connected the orbits of the planets to the five familiar known characters. He placed the cube between Saturn and Jupiter, and the tetrahedron was between Jupiter and Mars. Even in *Harmonices Mundi* (1619), Kepler used the regular 3-dimensional geometrical shapes to delineate the orbits of individual planets, although in the meantime he found that the model cannot be completely accurate. That great idea was related to Kepler's thoughts about the symmetry of crystals published in his Prague observations of the first snowflakes in the new year of 1611. He thought about the surfaces and crystalline forms with the metal compounds themselves, thus forming

alchemical connections between planets and metals that are still present in the name of Mercury.

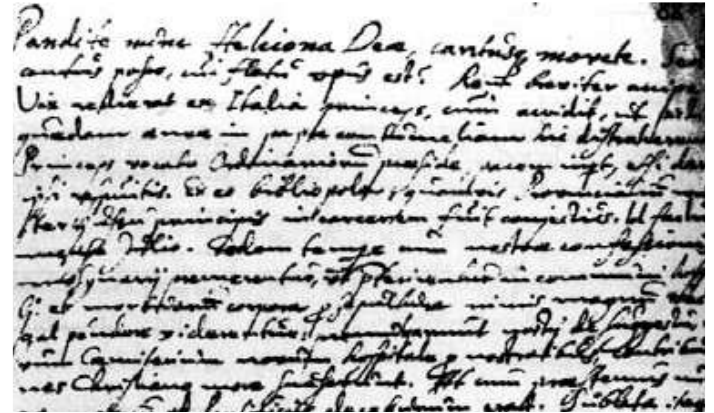

Figure 3-45: Kepler's letter from Graz, mailed on 8. 12. 1598 to his teacher Maestlin to Tübingen with a report about staying in Petany (Petanjci) in his 40th line (Stuttgart, Württemberg Regional Library, Code Math Foll 14a, pages 78-86).

In Kepler's youth, the era of Catholic tolerance towards Protestant religions was abandoned for many decades to come. On 23 September 1598 the newly powered wind was announced by Archduke Ferdinand II, who commanded all Protestant pastors and teachers to leave Graz in six days. The measure seemed impossible to everyone at first. On September 28, 1598, he ordered them to leave Graz by the sunset. They should leave Styria and other areas of inner Austria in a few days or face their death penalty. In a month (October 29, 1598), the same cruel measure surprised the Ljubljana preachers and lecturers. Together with about forty other teachers and pastors from Graz and Radgona, Kepler headed towards Zrinski's estates in Varaždin. The violence was mitigated so that they gave farewell with their last salary pocketed. The exiled victims soon found their shelter in a castle on the nearby estate of Count Nádasdy in Petanjci in the royal Hungarian Prekmurje, just a few miles east of Bad Radkersburg (Radgona). They used the church in the nearby village Tišina (Silence). They were the first Protestants in those now Slovenian settlements. Since they did not know the Slovene language of the locals, it was difficult for them to purchase food, which was therefore imported from Radgona. Kepler retained his good relations with the Bavarian Catholic Chancellor and the Graz based Jesuits. Therefore, he was able to return to Graz after a

month, while the rest of his company continued to live in Prekmurje. Kepler was particularly helped by his service of regional mathematician-physicist, which was not dependent on political circumstances related to religion, so he had his unique chance of returning after one month of exile. Kepler's "trip" to Prekmurje further contributed to the resurgence of his theories of vacuum and crystal surfaces in Slovenian places, where many clever readers bought his works. He published his ideas on crystal surfaces in Slavic Prague immediately after returning from the Slavic Slovenian areas, so that he must have at least somehow designed them during his stay in Prekmurje.

3.2.3.8 Concluding Remarks on Vacuum of Trubar's Days

The special kind of circumstances before the start of the Counter-Reformation in the Inner Austrian capitals lead the flower of Tübingen scholars into Inner Austria: Frischlin went to Ljubljana, Megiser to Klagenfurt and Kepler to Graz.²²⁵

Tubingen thus did not only provide Slovenes with Trubar's Protestant press in Slovenian and other languages, but also with fruitful newly designed ideas about vacuum, crystals and surfaces. Both bore its fruits in the next generation, when Ljubljana prince Vajkard Janez Auersperg as a youngster converted from Protestant to Catholic faith to become the main Guericke's assistant in vacuum experiments. Janez's ancestors were widespread supporters of Trubar, who was the subject of Janez's grandfather, former Paduan student Baron Krištof Auersperg, a resident envoy at the National Assembly in Augsburg in 1582.

Only one year after Auersperg's participation in Guericke's vacuum experiments in Regensburg the Diocesan vicar Upper Carniolan (Gorenjec) native Filip Terpin (Trpin, * 1603 or 1604 Selca above Škofja Loka; † 23. 6. 1683 Šmartno by Kranj) also listed technical, military and natural science-mathematical books on the conclusion of his division of World History books. Such arrangement was at that time in the habit.

²²⁵ Röckelein, Bumiller, 1990, 107.

3.3 Conclusion

The evolution of vacuum techniques by the invention of the barometer and vacuum pump can only be compared with the century later installations

Table 3-3: The Diocesan library of Ljubljana books in Gornji Grad which contains discussion of the vacuum. They were listed on page 21v of Terpin's census from 1655

Author	Title and format	Year and place of the print
Jordan, Gregor	Theatri coeli et terrae	1591. Coloniae (duplicate, in fact: <i>Prophetiae seu vaticinia XIII tabellis expressi de horrendis calamitatibus orbi terrarum impendentibus</i>)
Bordini, Francis	<i>Quaesitorum, et responsorum mathematicae disciplinae</i>	1573. Bononiae: Benacci
Padovani, Giovanni	Viridarium Mathematicorum, Quarto	1563. Venetiis (Venice)/Bologna Zalter
Ziegler, Jakob	Ziegler comment. in lib. 2 Plinii de Astronomia	1531. Basileae: Henric Petri
Zwinger, Theodor	<i>Theatrum Vitae Humanae</i> toms 1- 2. 3 anno in fol. Tab.	1565 and 1571. Basileae: Froben

following the breaking vacuum cathode ray tube experiments after Geissler achieved a repeated Torricellian mercury experiment in a glass tube in 1857. He reached the pressure of 1 mbar in barometric mercury tube after the Plücker's Bonn order. Half of a century later, a new upheaval was followed, when this kind of fun toy was suddenly used in the advanced science of emerging quantum mechanics. Today's surprises are the result of their technological use. Despite of the subsequent sequence of great achievements, it seems that the Slovenians most likely contributed to the progress at

the very beginning by Auersperg's helping Guericke's experiments and, consequently, with the growing interest in the vacuum among Carniolans, which is proven by unexpectedly many early discussions about the vacuum in libraries in then Slovenian areas. Therefore, the writer of these lines would have imagined that Janez Vajkard Auersperg, as a Guericke's assistant, should become part of the public image of the Society for the Vacuum Technology of Slovenia, since Guericke in his book acknowledged Auersperg's share in their experimental success,²²⁶ and it is unlikely that in the Slovenian areas there will be another such success anywhere soon. To this end, we propose the appealing version of the sign of the Society for Vacuum Technology of Slovenia, which can further emphasize the Ljubljana share in the progress of vacuum techniques on a global scale.

²²⁶ Guericke, 1672, 109 paragraph 27: reprint 1986.

II. Fugue: Pumping & Measuring of Vacuum Related New Materials

4 Early Metrology: Barometers & Manometers

4.1 Experiences with Vacuum in the Middle of the 17th Century: the First Uses of Vacuum in Barometer

4.1.1 *Galileo's Disciples*

Gilbert was one of the first modern experimental researchers and has therefore successfully treated the unpredictable English perpetual virgin queen Elizabeth. Unfortunately, he was convinced that nature avoided the vacuum; although, on the other hand, he knew that the vacuum does not hinder the motion of the bodies above the Earth's atmosphere. Two differently imagined types of empty were still battling ghosts. Galileo challenged Aristotelian authority with an experimental approach to science. According to Aristotle, the movement was focused on the balance that was defined by the characteristics of the body. The speed of movement decreases with increasing environmental density. Galileo summed up the concept of acceleration by Strato of Lampsacus. He distinguished the concept of vacuum from metaphysics and attributed physical properties to it, such as zero density and viscosity. In the first day of talks on two new sciences, Galileo's Sagredo proved the final speed of bodies in a vacuum. So, Aristotle made a mess. Galileo communicated two novelties:

1) In the vicinity of Earth all bodies fall with the same acceleration; the substance in the surrounding area obstacles their free falls.

2) The vacuum is a substance with zero density and zero viscosity.

Galileo's vacuum was described as the extreme example of the lowest-density environment. This avoided Aristotle's fear of the emptiness, which Galileo put on the funny tongue to his simple hero Simplicius with the assumption that "the empty space itself opposes its own creation, which is not in accordance with the supposed economy of natural phenomena."²²⁷

Galilei used a new concept of "microscopic voids in matter" to avoid a direct dispute with Aristotle's deflection of the vacuum. He attributed these to physical properties and thus introduced the emptiness into physics through the back door. The philosophical description of the empty was necessary for Galileo's contemporaries to undertake research into the vacuum. For a long time, they knew the primitive ways of pumping. Their improvement and systematic exploration only flourished after Galileo's reflection was based on such a practice. The theory of vacuum initially led experiments, but soon experiments with powerful steps overtook their interpreters. The emptied voids become a driver of progress. Galileo's pupils did not use air pumps, although with it, the ancient Greeks had pumped flutes in their musical instruments. Water pumps were known in ancient Alexandria and in the mines of ancient Rome. The famous Roman engineer Vitruvius described them; he was followed by Agricola in his famous book on metals, which was purchased in Ljubljana in 1678. With the pumps, a vacuum of 0.33 bar (250 torr) was obtained in the 16th century. The constructors did not know anything about such exact results as they had no proper tools to measure the pressure. Galileo tried to estimate the force needed to create a vacuum. The problem connected pumping of water vertically upward with Archimedes' screw and with water pumps. Miners told Galileo that the height cannot exceed 34 or 35 feet or 18 elbows, which is today's 10 m. Thus, the senator's son Giovanni Battista Baliani (1582 Genova-1666) unsuccessfully constructed the siphon in Genoa in 1630.

²²⁷ Galilei, 1964, 124–125.

Evangelista Torricelli was born in Faenza south of Bologna, where he graduated the Jesuit college. After studying at the University of Rome, Torricelli became Galileo's secretary and successor in Florence.



Evangelista Torricelli (*1608; † 1647)²²⁸

In the 17th century, technological problems were solved with specially prepared experiments. Berti set up an adapted "pump" in front of his house in Rome in 1640, while he had a direct influence on Galileo's disciples.²²⁹ Berti's device was basically a water barometer, but he still had to wait for the correct explanation.²³⁰ He filled his 10 m high lead tube with water and connected its open end with the collector. He did not manage to show persuasively that the emptied space does not translate the ringing from its interior, which would convince the contemporaries of the existence of a vacuum. He was assisted by the Jesuits Zucchi and Kircher,²³¹ as well as Torricelli along with them. Torricelli happened to be in Rome at the time, as all the roads lead to Rome. They all admired the experiment, but at the same time each of them offered his different explanation of the results. As much people, so many opinions. At that time, in 1639/40, Kircher began to teach mathematics at the College of Rome. He continued with the lessons between 1644 and 1646,

²²⁸ Sparnaay, 1992, 2.

²²⁹ Hablanian, 1984, 17–18.

²³⁰ Madey, 1984, 9.

²³¹ Kircher, 1650; Middleton, 1964, 15; Hellyer, 1998, 187.

and he later set up a museum with a vacuum pump and other unusual devices in his premises of Roman college. His collection became one of the wonders of the eternal city.

Kircher's pupil, the German Jesuit Schott, reported all about Berti's experiment in a book that was soon on sale in Ljubljana.²³² Thus, Slovenian ancestors in today's Slovene countries quickly learned about the first experiments with a vacuum (Fig. 4-1).

Galilei died on January 1, 1642, almost 78 years old. Torricelli's barometric experiment was designed very likely only in the spring of 1644, and not a year earlier. Torricelli's passed his instructions to another Galilean pupil and founder of the Florentine Academy of Cimento, Viviani.²³³

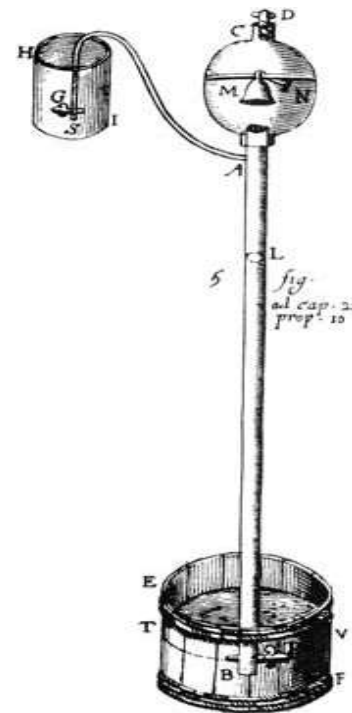

Figure 4-1: Berti's vacuum device²³⁴

The experimental trial was supposedly completed before 13th June 1644, when Torricelli described it in Florence in a letter to the future Cardinal Michelangelo Ricci (1619 Rome-1681 Rome). Ricci was a Roman student of Galileo's student Benedetto Castelli (1578-1643). Torricelli called his experimenters all the time with the pronoun "we",

²³² Schott, 1664; Mayr, 1966, 89.

²³³ Redhead, 1984, 31.

²³⁴ Madey, 1984, 10.

which certainly included at least Viviani. He used a two "braccia" (1.2 m) long glass container. He did not report about the thickness of the glass and the width of the tube. The Venetian masters, who greatly surpassed all contemporaries, could have designed such a vessel. Thus, in the middle of the 17th century, Colbert had to trick Venetian authorities to steal their secrets of making mirrors for the needs of the French court. The closed top of Torricelli's tube was expanded into a pumpkin, as was usual with the then Italian thermoscopes, while the Dutch tubes were mostly made in the form of a letter J. In 1624 the term thermometer was first used by the French Jesuit Jean Leurechon (1591 Bar-le-Duc-1670 Pont-à-Mousson) or by his local printer engraver of University of Pont-à-Mousson Jean Appier Hanzelet (1596-1647) in their *Les Récréations Mathématiques*²³⁵ published under the pseudonym Hendrik van Etten. Ozanam, Schwenter and many others used the similar titles few years later. Likewise, the extension pipe at the closed top was drawn by the supposed Jesuitical fan Marcus Marci in his letter mailed from Prague to Kircher on January 25, 1642. Kircher himself proposed the use of mercury in a thermoscope because he knew about its production in the Carniolan Idrija. Thus, all elements of the Torricellian experiment were known even before it was placed. Nonetheless, no one in Italy has disputed Torricelli's priorities. Consequently, the Jesuit Fabri claimed that he had made a similar experiment at the Jesuit College of St. Trinity in Lyon around the year 1641²³⁶ while Magni demanded his own championship for his experiments in Warsaw.

Torricelli reported: "... We filled (a vessel) with mercury. We tightened its mouth with a finger and turned it into a mercury vessel C. It showed up its the emptiness, and nothing has happened in the empty part of the container. The length AD has always been filled to the height of one and a quarter of Braccia and one inch (a total of 29.75 inches or 760 cm). To show that the vessel is completely empty, we filled the container below it with water to the point D. The vessel was slowly rising, and when water reached its mouth, we saw a drop of mercury at the neck (of a vessel). The great force filled the container with water up to the mark E. During the

²³⁵ Among its many reprints by Claude Prost in 1642.

²³⁶ Gorman, 1994, 12, 17.

experiments, the AE container was empty, and the heavy mercury was held in the neck noted as the AD.

The force, which holds the mercury upright and prevents its fall back into the container against its nature, is presumably in the AE container, and it originates either from a vacuum or from a strong diluted mercury. For myself, I suppose that the force is external and that it comes from the outside. The surface of the liquid in the vessel is pressurized by a mass of 50 miles high air. Should we then be surprised that the mercury in the CE container, where it is not pushed nor hauled, because there is nothing there, rises to such a level that it comes into balance with the outer air that pressures it. The water will rise to almost 18 braccia (10 m) in a similar but much longer container. This is much higher than mercury rises, as mercury is heavier than water, but it must strike a balance with the same pressure that presses on both of the liquids..."



Figure 4-2: Torricellian mercury barometer²³⁷

²³⁷ Wolff, 1758.

Torricelli followed his teacher Galileo's turning around of ancient questions, heads upside down. Instead of exploring how the "fear of emptiness" drags the column of Idrija mercury upwards in the closed side of the U-tube, he explained that it is pushed up by the air pressure from the open side of the U-tube. By changing the question, "fear of emptiness" gradually lost its meaning as it was replaced by the term of (reduced) air pressure (Figure 4.2).

Upon returning from Florence and Rome, in the spring of 1645, Descartes' former classmate Mersenne reported Torricelli's success in Paris.

In 1645, the grand duke Cosimo II's (1590-1621) son, the art-collector Cardinal Giovanni Carlo de'Medici (1611-1663) presented Torricelli's experiment to Kircher and other Roman Jesuits, as we read in five years later Kircher's Report.²³⁸

On 25 October 1647, Torricelli suddenly died of fever. About a month later, on December 13, 1647, Descartes reported to Mersenne in Paris that he set a Torricelli's type barometer.²³⁹

Despite the Thirty Years' War, scientific news spread even in the burning German countries. As early as 1646, the Capuchin Magni set up the similar Torricellian experiment at Ladislaus and Louise-Marie's courts in Warsaw. The Queen's Secretary, Noyers, immediately informed the French physicists about the event. The Polish court was very enthusiastic about science, because the queen brought to the palace one of the first models of Pascal's computer and wrote a letter to Kircher. Researchers from the Ujazdów Observatory near Warsaw collaborated with Parisian astronomers Boullualdi, Pierre Petit (1594-1677) and Adrien Auzout (1630-1691). In 1663 Auzout demonstrated the use of a telescope without a tube,²⁴⁰ and later investigated the vacuum.

The last ruler of the Vasa dynasty, Jan Kazimierz, was also interested in science. Before the marriage with his half-brother Ladislaus's widow, the energetic Louise-Marie (Maria Ludwika), he was a

cardinal and Jesuit; after his resignation from the Polish throne, he preferred to live in the worldly France. In 1654, Magni described his experiment to Guericke, prince Auersperg and other curious people at the National Assembly in Regensburg. Guericke's father was a member of the Polish royal court during his young years; so, he knew the situation in Warsaw well. The Regensburg audience did not fully believe Magni, as they have already heard something about Torricelli's and Viviani's experiments. After arguing, Magni admitted with his heavy heart Torricellian priority.²⁴¹

Magni first described in detail the passage of light through the air and through a vacuum.²⁴² As a Capuchin, he was an unpleasant interlocutor to any Jesuit, especially with his sharp criticism of Aristotelian opposition to the vacuum. A magnificent Magni's critique of Aristotle's rejection of the existence of a vacuum was the worst challenge to the peripatetic guys of that time.

While continuing disputes with scholastic annoyed him, Magni found himself in Vienna. He was at the height of the path of life, and he tried to get even the cardinal hat. Of course, Auersperg would rather see a cardinal hat on his own head in those windy days; therefore, he did not support his old acquaintance Magni. He did not become too angry when the Pope²⁴³ issued an order for arrest of Magni to bring Magni from Vienna to Rome after the advice of the Jesuits in 1661.²⁴⁴ Magni's ideas remained a lasting thorn in the heels of all the advocates of Aristotle's science. The grandson of Auersperg's tax collector Anton Erberg, along with other Carniolan Jesuits, vehemently criticized the long-dead Magni's description of the vacuum even a century later.

4.1.2 *Pascal for the Frenchmen*

Pascal investigated the air pressure between October 1646 and April 1652. First, Petit reported on Torricelli's experiment to the family of Pascal in Rouen. Blaise Pascal repeated an experiment with the help of his father Etienne, Petit and their neighboring glassblowers. With the pump and

²⁴¹ Hellyer, 1998, 264.

²⁴² Guericke, 1986, 92–93, 108; Sparnaay, 1992, 4, 52.

²⁴³ Aleksander VII, the Pope between 1655–1667.

²⁴⁴ Gorman, 1994, 19, 21.

²³⁸ Gorman, 1994, 19.

²³⁹ Redhead, 1984, 31.

²⁴⁰ Helden, 1995, 196.

according to the Torricellian method, they proved that mercury cannot be brought above the height of two feet, three inches and five lines. The water could be pumped much higher, up to 31 feet, and the oil up to 34 feet. The results were in the ratio of then available values of the density of those three liquids. Pascal immediately publicly exhibited experiments with communicating vessels and Torricelli vacuum over oil, water and red wine in front a glasswork shop in Rouen. Especially the latter was heavily cheered by passers-by. Blaise Pascal also investigated the pressure above water and wine in over 12 m long sailed containers. He proved that the vapor pressure over water or wine which evaporates faster does not affect the height of the column of the liquid in the tube. One of the demonstrations was seen by 500 knowledgeable and most of all thirsty neighbors.

On 23. 9. 1647, Descartes visited Blaise Pascal in Paris where Blaise's sister Jacqueline nursed him during his illness. At the first meeting, many friends and admirers were gathered. In the continuation of the conversation, the opinion of the sick Pascal was represented by mathematician Roberval. A sharp exchange of views ended the next morning with Descartes' visit to Pascal, who then probably imagined his famous measurements of heights with a barometer.

Because of Magni's demands for priority, Pascal hurried next month with his publication of *New experiments with Emptiness*. At the same time, he wrote a preface to his book about the vacuum, from which only parts were preserved.

The Jesuit Noël urgently sent his criticism to Blaise. He was a respected Rector of the College of Clermont (later Louis le Grand) and former Descartes' Professor of Philosophy at Le Fleché College.

On 29. 10. 1647 Pascal answered Noël that the space above the column of mercury is empty, because we can hardly imagine an invisible substance, although we can invent it. Pascal's thought sounds nice even for today's time:²⁴⁵ "... the empty space is in the middle between matter and nothing."

²⁴⁵ Sparnaay, 1992 10, 14, 15.

So, the vacuum is not a mere nonsense, and it is not clearly a nothing. In January 1648, Noël supported Aristotle's opinion in the book "Fullness of the empty". Blaise Pascal refused to answer him but described his position next month in a letter to Jacques le Pailleur. A further controversy with Noël angrily interrupted Pascal's father Etienne, as Blaise felt that Noël "changed his views more quickly than he himself could answer." In the Latin translation of his book, Noël later gave the recognition of the experiments of an ever-famous Pascal.

At the same time, the Englishman Hobbes wrote to Mersenne that Noël's experiments were not enough. But Hobbes, like Noël, was also a "plenist." He did not believe in the existence of a vacuum and preferred to claim that the "invisible substance" remains after pumping. His emptiness seemed a contradiction by itself; but this did not bother the convinced "vacuists", among them the French priest Gassendi, the professor of mathematics and astronomy at the Royal College of Paris since 25. 2. 1645.

In 1648, Hobbes wrote in French language to Mersenne, just before leaving Saint-Germain. He claimed that with Torricelli's experiment only a part of the air was removed; a tiny substance remains, like the passage of smoke through the water. Pascal responded to Hobbes's criticisms with a humiliating exclamation: "Hobbes, who knows this name in France?" The question was extremely offensive, as Hobbes lived in Paris between 1635 and 1640, and then returned to England. He subsequently participated in vacuum experiments in Paris and reported them to England in the spring of 1648.²⁴⁶

On November 15, 1647, from Paris, Pascal wrote to the Judge Périer, the husband of his older sister Gilberte (1620–1668). Blaise asked him to measure a supposed change of lengths of about 4 kg of mercury in a barometer at the height of 1465 m of the Puy-de-Dôme mountain near Pascal's Clermont-Ferrand birthplace in the Auvergne region, 150 km west of Lyon. Périer should compare his result with the measurement at the foot of the mountain. Only ten months later, on 19 September 1648, Périer and his companions carried out several measurements.

²⁴⁶ Bernhardt, 1993, 229–239; Schaffer, Schaffer, 1993, 83, 86–87, 122.

For companions and witnesses, he took esteemed folks from the city of Clermont: The Abbot Bannier (Boniere) of the Minim (Minime) religious order monks, the canon of the Clermont cathedral church (*Cathédrale Notre-Dame-de-l'Assomption de Clermont-Ferrand*) Mosnier (Monière), the councilors of the court of Aides La Ville (Lavaille) and Begon (Begonn), and the doctor La Porte (Laporte) as professor of medicine in Clermont. At 8 am in the monastery garden at the foot of the hill, in three experiments with two identical barometers, the same height of the mercury column was measured. The result was 66 cm each time.²⁴⁷ Then one of the two pipes filled with mercury was brought to nearly a kilometer²⁴⁸ higher peak of the Puy-de-Dôme. There they measured by 3 inches and a half-line (8 cm) shorter column. The experiment was repeated five times in different suitable places and under different conditions: in the shelter and in the open, in good pleasant weather, in the rain and in the fog. The result was always the same: 23 points and 2 lines (58 cm). On their way back, they measured 25 points (62.5 cm) in the lower place "slightly above the monastery gardens" of the *église Saint-Pierres-des-Minimes*.

When they returned to the monastery garden, the Father of Minim religious order Chastin (Chastain) reported that the level of mercury in U-tube stored there was all the time on the same level, although the weather was changing with the wind, rain and fog several times. Périer then the elevation of mercury in the tube that he carried with him to the top several times. Each time, he got 26 points and 3.5 lines, which is today 66 cm.

Périer described his experiment in the garden and on the hill to the Oratorian priest de la Marc (abbot Mare); the next day he submitted a measurement at the top of the Notre-Dame-de-Clermont cathedral church tower, which was 27 toise (fathoms), 53 m above the garden. As they climbed the belfry, the mercury column dropped there by 2.5 lines (5.6 mm). The result was somehow disappointing; unfortunately, it was too late to find that heavy and awkward mercury barometers do not even have to be carried at the high Puy-de-Dôme, as Blaise's ideas

could be easily proved on the bell tower of the nearby church. On 19. 9. 1648 Périer reported to Blaise about the experiment and submitted mercury column measurements for every 100 toise (fathoms) (195 m) of height. Pascal repeated experiments on the Saint-Jacques tower with a height of about 25 toise (fathoms, 49 m). The difference between the levels of mercury was more than two lines (4.5 mm). At the top of the staircase with about 90 steps, he noticed a difference of 1.1 mm.²⁴⁹ Thus, even the physically weak Pascal was able to prove his own theory.²⁵⁰ In fact, the measured results were at hand for centuries, but nobody bothered to pick them up because of the lack of motivations.

At the end of same year, Pascal published his own and his brother-in-law's letter together with the results of the barometer measurements in various French cities: in Paris, in his domestic Auvergne region and in the offshore Dieppe northwest of Paris. The total weight of air in the the atmosphere was estimated at 4 million tons.²⁵¹ This figure was, of course, beyond the human imaginations of the time and testified about the triumph of mathematical physics over commons senses.²⁵²

In April 1652, Blaise demonstrated the operation of his own arithmetic computer at the Parisian saloon of his relative Richelieu and explained his vacuum theory. His research later evolved hydrostatics, which he wrote in 1653. His pamphlet about the discussion of the weight of the air and the balance of liquids was published much later in 1663. With the weight of the air concept, Blaise proved that the weather influences air pressure²⁵³ and thus founded the modern weather science later called meteorology by Aristotelian term.

To recover from the arduous writing about those puzzles, in the following year Blaise took a trip to the surroundings of Paris in late October/early November 1654. Suddenly, the horses went wild, and Pascal "miraculously" got out of the carriage and immediately completed his experiments. He abandoned his mathematical and physical research

²⁴⁹ Half of a line.

²⁵⁰ Sparnaay, 1992 15, 17; Tarasov, 1979, 128–129.

²⁵¹ 8.5 billion of French pounds.

²⁵² Pascal, 1648.

²⁵³ Bernhardt, 1993, 227; Tarasov, 1979, 330.

²⁴⁷ 26 inches (doim) and 3.5 lines. The correct result should have been higher.

²⁴⁸ 500 tois or fathom by 1.949 m, therefore 974.5 m.

because of wild-fired horses; the same kind of more polite animals which almost simultaneously brought glory to Guericke several hundred miles east on 8. 5. 1654. Thus, the year 1654, in truth, we can obviously call a horse year, according to the scientific merits that springs acquired and at the same time wasted.

On 5 December 1661 and again eight days later, six years younger Huygens visited the sick and prematurely aged B. Pascal in Port Royal near Paris. Huygens reported that they discussed the "diluted water" force, today we could say steam in a steam engine. They also mentioned telescopes imported from Huygens' Dutch homeland. At that time, Pascal was no longer interested in physics, but mainly in theology; but he did not try to get Huygens into theological talks. The Jansenists were present, although the Protestant Huygens was not particularly interested in disputes between Catholics; he was more intimidated by the growing intolerance of his own Protestant faith, which forced him to leave the Parisian beauties all too soon.

The controversy between defenders of the "full" and the adherents of the vacuum was annoying for the next-generation scientists. Even many admirers of empty thought that after exhausting the air, something remains in the container. In the theories of Newton and Huygens this "something" was ether. Leibniz, in his last letters of May 1716, rejected the existence of a vacuum²⁵⁴ and never repented. The philosophical implications of the void seemed much worse than the assumption of the infinitely small one that Leibniz used in the development of the differential calculus.

4.2 Touching Vacuum for the First Time

4.2.1 Introduction

The first Carniolan vacuum researcher, Janez Vajkard Auersperg, did not publish many of his works, since he lived before the modern motto publish or perish; correspondence with the relevant contemporaries was quite enough in those Baroque

completely different unmodern times. That's why today's research in the history of physics is increasingly focused on the study of manuscripts or at least the longer handwritten notes in books. This can also be expected, since the main printed books have long been read and illuminated from many aspects, so it is difficult to learn out something innovative from their reading. The manuscripts offer exactly that: the original works.

Due to historical data, most early manuscripts on early vacuum techniques are now stored in European and Asian libraries. Some of them, however, traveled in one way or another, across the large blue pond called the Atlantic Ocean, and they are talking about themselves in our next story.

4.2.2 *Two Approaches to Vacuum Dedicated to the Late 17th Century: Manuscripts in Oklahoma University*

4.2.2.1 Paolitto's Vacuum Barometer

Four and a half centuries ago, the peer of the Prince Janez Vajkard Auersperg, the Italian Valentino Paolitto, signed himself several times in the cover of the handwriting was, intended for the teaching of applied mathematics, which consisted mainly of astronomy, also of some vacuum and other technical explanations.

In Paolitto's time, the vacuum was a fundamental issue of theology, but at the same time, they studied voids as the lesson of applied mathematics, closely related to the physics of the vacuum. Paolitto's manuscript, in course of those habits, described four fundamental elements of the world, which he dealt with one after the other. Paolitto's writer concluded his discussion with the treatment of water and air; these two have occupied the ideas of liquids and gases in modern terminology. In the next chapter 16, he proved the geoid's circularity and scribbled it with excessively large images of ships and buildings on the bump of the globe of the Earth. He then proceeded to tides, and gently hid Galileo's

²⁵⁴ Sparnaay, 1992, 19, 39–40; Frankfort, 1976, 92, 98.

erroneous attempts designed to prove Copernicus's rotation of the earth with tides.²⁵⁵



Figure 4-3: Paolitto vacuum barometer from the second half of the 17th century (Paolitto, after 1657, folio 15v, with the permission of the curator of the history of science at the University of Oklahoma, Dr. Kerry Magruder)

Paolitto's writer proved the hydrodynamic paradox by quoting modern research in hydrography and geography.²⁵⁶ He then proceeded to undertake another treatment of gases, which he has usually referred as "airs"; at that time, they were not yet aware of any gases that were not part of the atmosphere. Immediately at the beginning of the discussion, he cheered the reader with a nice picture of Torricelli's vacuum barometer, which he may have filled with Idrija mercury, although he only mentioned water in all his discussions. Depending on the ratios provided in his picture, the charge with water would not sound reasonable, since the emptied tube in the picture would be extremely large, at least a few meters. Paolitto's writer ensured us that the appearance of the vacuum in the barometer does not in any way cause movement under the influence of force, as the true cause of the vacuum pumping is the dilution force which the writer and his contemporaries conceived for that purpose. The

²⁵⁵ Paolitto, after 1657, 21r, 21v, 23r.
²⁵⁶ Paolitto, after 1657, 23v.

recipient, marked with the letter B,²⁵⁷ connected an opening facing down into the container with the liquid that he had noted with the letter A. To facilitate the observation of the experiment, the liquid was painted with a color of suitable properties. Closed air in the recipient B dilutes and therefore raises the liquid from the container through a suitable closure marked with the letter C; the liquid compresses the air in the recipient B. In the next second section of the chapter on gases, Paolitto's writer moved to motion under the influence of wind.



Figure 4-4: Paolitto's vacuum barometer from the second half of the 17th century in a mirror image at the start of a second vacuum chapter on air distribution (Paolitto, after 1657, folio 15v, with the permission of the curator of the history of science at the University of Oklahoma, Dr. Kerry Magruder)

The distribution of gases in the atmosphere, composed of three allegedly different used parts, was narrated as a transition to the description of the fire. In this meteorological part of the manuscript, he described the elements of the atmosphere in a series, with the external, third, very hot part used for the passage of comets,²⁵⁸ for Paolitto's writer the comets were still part of the meteorological phenomena below the Moon, although Tycho Brahe, Kepler and other established astronomers have long been

²⁵⁷ Paolitto, after 1657, 25r.
²⁵⁸ Paolitto, after 1657, 25v.

proving that Aristotle offered gravely erroneous descriptions of comets.

Paolitto's manuscript can be very well dated when reading its ninth chapter on Saturn, where the author explicitly quoted Kircher's opinion about the Saturn's ring,²⁵⁹ which was soon corrected by the Dutchman Christiaan Huygens in 1655 with a better telescope of his own manufacture. Huygens published his findings in *Systema Saturnium* in The Hague in 1659. In 1643, during his Bologna observations, Kircher represented Saturn's ring as two sympathetic ellipses on each side of the planet, which he painted in his famous book *Ars Magna* in 1646 and in a revised reprint in 1671. Besides A. Argoli, Kircher used to be the main source for Paolitto's manuscript, in good and bad. Therefore, the author of Paolitto's manuscript must have been in touch with the Jesuits of Kircher's school, maybe with North Italian Kircher's student Lana from Brescia.

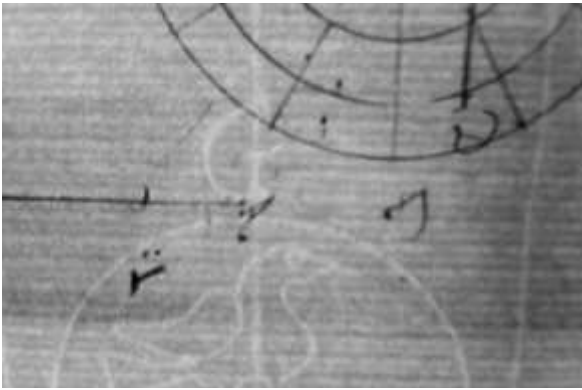

Figure 4-5: A watermark of a circular bird on three hills or rather on three eggs in Paolitto's manuscript.²⁶⁰

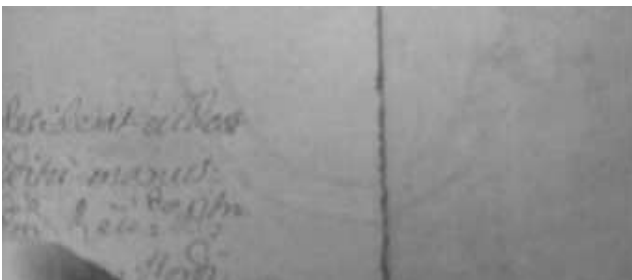

Figure 4-6: A watermark with a ring, noted in conveniently connected two corners of the Zacco's manuscript used for better transparency.²⁶¹

²⁵⁹ Paolitto, after 1657, 56r, 56v.

²⁶⁰ Paolitto, after 1657. Courtesy of University Oklahoma and dr. Kerry Magruder.

4.2.2.2 Zacco's Vacuum

Paolitto's younger contemporary was the Venetian patrician Augusto Zacco (Augusto Antonio M. Zacchi, * 10 November 1662, Padua; † 18 February 1739, Treviso). Zacco was consecrated on June 1, 1687, and on 15 November 1706 he was appointed Archbishop of Corfu in Greece, which Zacco's native Venice almost lost during their war against the Ottoman Turks. On 22 November 1723, Zacco became Venetian Archbishop of Treviso near Piava river on the Slovene-Friulian ethnic border near the borders of then Habsburg Monarchy, which also acquired Lombardy with Milan of those times. Treviso north of Venice should not be confused with Tarvisio (Tržič) on the tripoint border areas somewhat eastern. As a teenager, Augusto Zacco tried to write a small, perhaps a student book with comments on Aristotle's physics and thoughts about a vacuum in the spirit of Tomas Aquinas. The manuscript was dated on the cover page, on the page before the end and on the ending, respectively in 1680, in August 1680, and finally in November 1681. It spread over the interval of a year and a half, which could be accomplished during Zacco's studies of physics! A little before Zacco's Ph.D., the University of Padua awarded the PhD to the first woman, the Venetian wealthy beauty Elena Lucrezia Cornaro Piscopia (Corner, * 1646, Venice; † 1684, Padua), who then became an university teacher of applied mathematics including physics of then highly popular vacuum.

In the second half of the manuscript, Zacco included his observations of the fourth Aristotle Book of Physics, where he discussed the eighteenth question about the vacuum in a total of eight pages²⁶² after the discussions of the locations. Regardless of Torricelli's and Guericke's experiments with the help of Carniolan Prince of Ljubljana Janez Vajkard Auersperg, Zacco rejected the existence of a vacuum;²⁶³ he did not even help himself with the experiments as revealed by Boyle, Pascal or Huygens. Thus, he entered the circle of Descartes or Leibniz, who also rejected the vacuum, although in

²⁶¹ Zacco (Zacchi), 1680/81. Courtesy of University Oklahoma and dr. Kerry Magruder.

²⁶² Zacco, 1680/81, 4: 10r-13v.

²⁶³ Zacco, 1680/81, 4: 10v.



Figure 4-7: The indication of Athanasius Kircher and his publications from 1657 or later in 1671 about Saturn in *Ars Magna*, as recorded in Paolitto's manuscript (Paolitto, after 1657, folio 58v, with the permission of the curator of the history of science collection at the University of Oklahoma).



Figure 4-9: Nazzaro Nazzari's (Nazario Nazari, * 1723/4, Venice; † after 1793) Venetian post-mortem portrait of Zacco, oil in canvas, 78 cm × 60 cm, hanging in the Sagrestia dei Canonica cathedral in Padua. Zacco was the canon of Padua named in 1689, and the Archbishop of Corfu, where he became famous for his defense against the Ottoman Turkish invaders.²⁶⁵



Figure 4-8: Zacco's portrait in oil stored in the Milan house of heirs of his family Adler-Zacco after Lorenzo Zacco from Padua took it over in 1933. Zacco is in bishop's suit; in the right hand he holds a book, probably about the vacuum of his days.²⁶⁴

Venice at the nearby University of Padua, vacuum already for many years acted as a sure fact under the influence of Galileo's heirs of the Florentine Academy. Like many of his cautious contemporaries, Zacco's vacuum more influenced theology than physics, although he seriously considered the possibility of moving in an empty space at the limited time;²⁶⁶ Aristotle, Descartes, or Leibniz assumed that in the vacuum without resistance, the body would fly long distances at the very moment that, according to the known physical laws, was rather strange. Among the most important Venetian advocates of vacuum was the astronomer Geminiano Montanari (* 1633, Modena; † 1687, Padua), who was invited from Bologna to the Paduan University chair of astronomy and

²⁶⁴ Bonora, Manzato, Sartor, 2000, 84.

²⁶⁵ Bonora, Manzato, Sartor, 2000, 209.

²⁶⁶ Zacco, 1680/81, 4: 11v, 12v.

meteorology in 1678/79. Shortly before, Montanari published his *Discorso sul vacuo* in Bologna in 1675, which his fans later reprinted in 1696 for the instruction of the future Venetian doge Pietro



Figure 4-10: Elena Lucrezia Cornaro Piscopia²⁶⁷



Figure 4-11: First page of Montanari's discussion of the vacuum in barometers with a sketch²⁶⁸

²⁶⁷ Piovan, Sitran Rea, 2001.



Figure 4-12: The cover page of the magazine that published the discussion of the vacuum (1696) of the Paduan astronomer Geminiano Montanari.²⁶⁹

Grimani (* 1677, Venice, 1752), who was enthroned in 1741. Grimani was a Venetian ambassador to France and England until 1719; there he used his knowledge of vacuum technologies, acquired at Montanari's class, for a particularly genuine friendly relationship with Newton himself. Montanari began to experiment with vacuum in Bologna at the end of 1665, after he improved Torricellian barometer so that he could measure differences in the specific weights of the used liquids, including the sea water. He also studied lead sinking into water according to Archimedes' law. To get the most accurate results he used a thermometer and tried to consider the temperature differences between the individual measurements.²⁷⁰ He was brave enough to accept the principles of Archimedes, Galileo, and Roberval,²⁷¹ although many of Galilean works were forbidden to him with the Papal index. From 1678 to 1687, Montanari traveled between Padua and Venice in a

²⁶⁸ Montanari, 1696, 291.

²⁶⁹ Montanari, 1696.

²⁷⁰ Facciolati, 1737, 2: 326; Montanari, 1696, 391, 393, 394; Favaro, 1917, 150.

²⁷¹ Montanari, 1696, 392.

permanent scientific collaboration with Carl Rinaldini after their discussions of the lunar eclipse on September 29, 1670.²⁷² The physicist Rinaldini became the mentor and hidden sympathy of the first woman with Ph.D. in philosophy and physics, Elene Lucrezia Cornaro Piscopia.

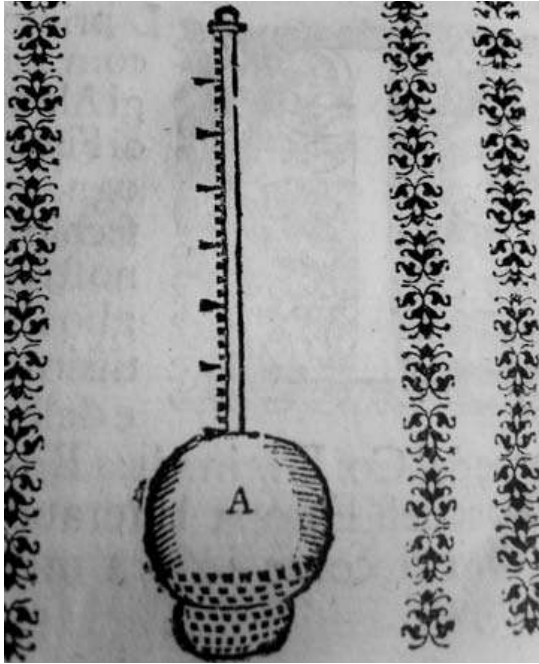

Figure 4-13: The sketch of the barometer on the first page of the paper on the vacuum of the Paduan astronomer Geminiano Montanari²⁷³

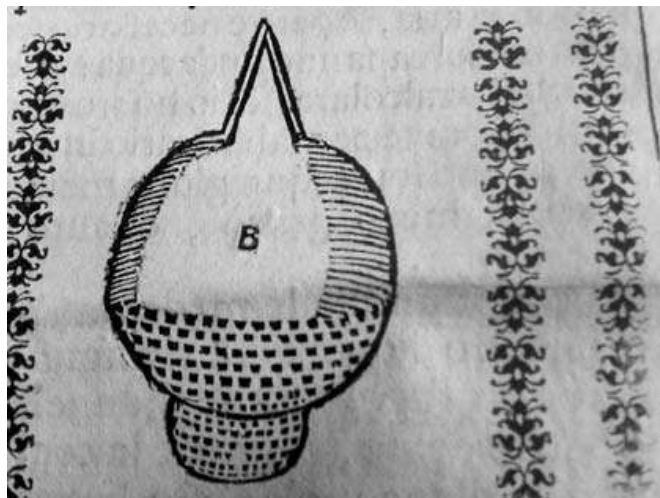

Figure 4-14: The first sketch of the barometer on the other side of the paper on the vacuum of the Paduan astronomer Geminiano Montanari²⁷⁴

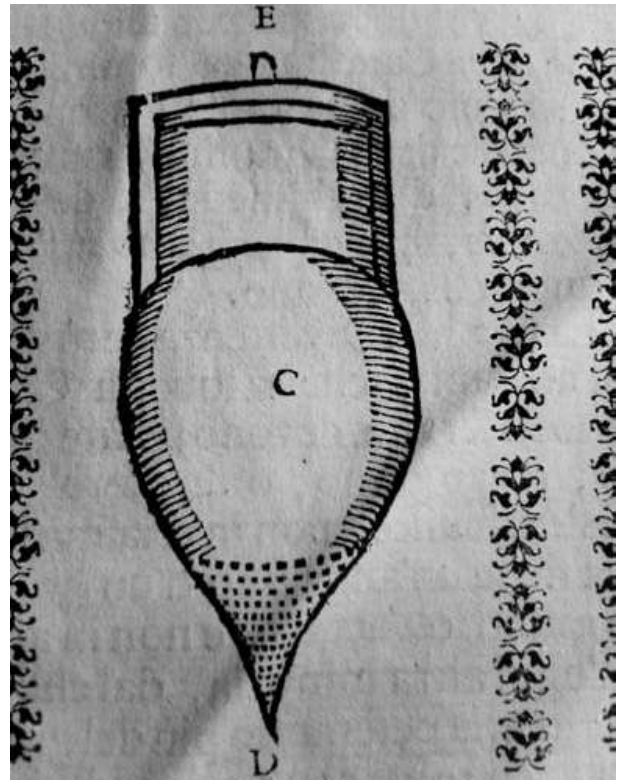

Figure 4-15: The second sketch of the barometer on the other side of the paper on the vacuum of the Paduan astronomer Geminiano Montanari²⁷⁵



Figure 4-16: Montanari's portrait

²⁷² Pighetti, 2005, 84.

²⁷³ Montanari, 1696, 291.

²⁷⁴ Montanari, 1696, 292.

²⁷⁵ Montanari, 1696, 292.

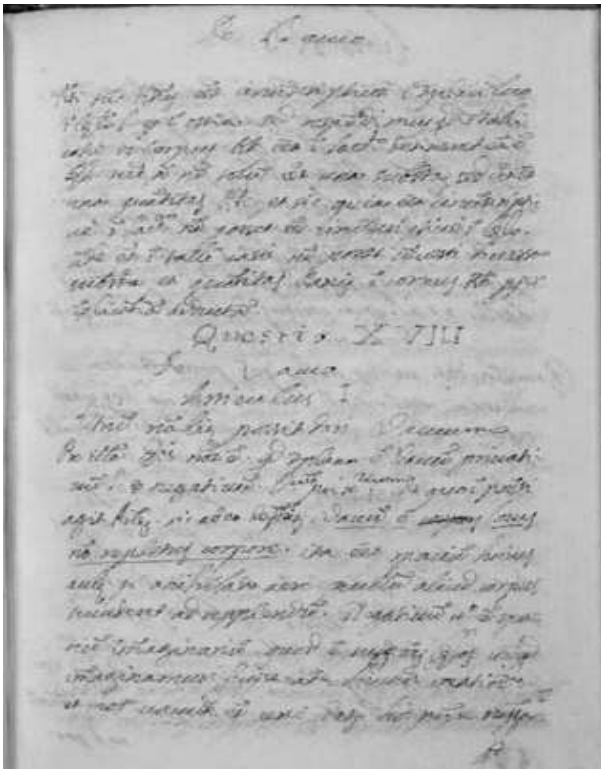

Figure 4-17: The beginning of Zacco's discussion of vacuum (Zacco, 1680/1681, 4, book on page 10r, with the permission of the curator of the History of Science Collection at the University Oklahoma, Dr. Kerry Magruder)

Zacco did not discuss experiments in a vacuum like the simple Torricellian barometer in Paolitto's *Sphaerae*. Because of this, Zacco could hardly be considered a student of the Paduan Professor Rinaldi, a distinguished member of the Academy in Florence, where Torricelli's barometer was largely the main attraction. Naturally, Zacco wrote about a philosophical vacuum, not of the so-called Boyle Emptiness (*vacua Boiliana*), which was considered primarily as a highly diluted air and not as a complete vacuum. The problems of vacuum were certainly inherited from the ancient and medieval problems of physics and metaphysics. Torricelli, Guericke, his assistant Janez Vajkard Auersperg, Boyle or Pascal enabled a great progress, but the problems of the empty have not been resolved forever, as we cannot yet achieve a total vacuum on Earth, nor in the universe where we still find somewhat filled although rarefied spaces. Zacco was certainly a young man with good eyesight during his writing of his booklet with such exceptionally small letters at a time when Ottoman and other wars damaged his Venetian homeland. In any case, with

his scholastic notion of empty, Zacco has somehow drifted away from the modern hints of his time.

4.2.2.3 Conclusions

Paolitto and Zacco's manuscripts were provided by Italian scholars of the late 17th century. Both are the echo of teaching at the then universities in Italy, especially in Padua, where many sons of fathers from today's Slovene territory also studied. Both manuscripts, though preserved in America, reflect in their own way the events among the educators in the lands that later became Slovenian republic.

4.2.3 Galileo's Relative in Carniola Propagating Early Vacuum Technology

The influence of Galileo Galilei on Carniolans started during the studies of Carniolan youths in Padua, where Counts Auersperg and the noble Valvasor also attended the university. Of course, due to their politically oriented life goals, the nobles did not enroll in the medical faculty where Galilei taught mathematical science. A different level is mirrored in the purchase of the Galilean analogue computer manufactured in his house, in a silver dear version for the rulers including Habsburgs and in cheaper metallic forms; among other things, it was purchased by Counts Auersperg for their palace in Ljubljana, later called Prince's palace, by Valvasor and by Janez Adam Petenegg as the Ljubljana host of Roberto Galilei. The third level of Galileo's influences was the acquisition of his books, including those forbidden, for the Carniolan libraries of Counts and princes of Auersperg, for their Siena classmate, the Radovljica manor owner Count Janez Ambrož Thurn-Valsassina (1616/1624-5, 1654), Janez Vajkad Valvasor, baroness Maria Theresa Wintershofen married Oršić (* about 1665; † 1700), for Franciscans in Kostanjevica and for other Carniolan lovers of good reading.

It is not fair to ignore the other paths of the penetrating of Galileo's ideas among the Carniolans. It's all about an unknown, perhaps even surprising influence of Galileo's relatives. The oldest among Galileo's relatives in Carniola was the chief Venetian trader with the salt Franc Galilei (* Florence; before

17 June 1647); he established himself as an Istrian entrepreneur in the areas of Rijeka, Bakar, Bakarac, Koper, Milje and Trieste in a harsh situation, which soon led to the Zrinski-Frankopan's conspiracy, also due to the actual duty-free zone in Zrinski's Bakar harbor, as a competitor of the Rijeka (Fiume) port with its imperial customs of St. Vid. In those times Bakar was the biggest port in those areas with subterranean springs of water everywhere gathered in an artificial lake called Jaz also used for washing the clothes in nearby waters of Perilo. Up the hill there were the Roman and Turkish houses probably used for the trade attachés' deals of Venetian and Ottomans, although the local legends prefer their different stories. Franc Galilei exploited the huge differences in salt prices between the Venetian and Habsburg territories. In addition to the Carniolan archival data on Franc Galileo's trade, Galileo Galilei of Florence connected with the Venetian trader Florentine nobleman Francesco (Franc) Galilei on 4 November 1632. Their deals coincided with the publication of the Galileo's Dialogue dei Massimi Sistemi (1632) before Galileo's call for a fatal trial in Rome culminated in Galileo's conviction on 22 June 1633. The trader Franc Galilei decisively contributed to the regulation of Galileo's Galilei's pension provided by the Cathedral of Brescia on the then Venetian territory.

The Lyonian banker and trader Roberto Galilei (* 1595, Florence) transmitted the messages of the imprisoned Galileo Galilei from Arcetri from Florence to Lyon and to Élie Diodatius (Elia, Elias, * 1576; † 1661). In one of the more shocking letters Galileo Galilei described his grief over the death of his daughter Virginia Mary Celeste Galilei (16 August 1600, Padua, 16 February 1634, Florence) and allegedly blamed the Jesuit for the process against him. Élie Diodati was a Swiss lawyer from one of the leading catholic families in Geneva, to where they moved from Lucca. With the help of Roberto Galileo Élie Diodati organized Elzevir's print of the last Galilean book *Discorsi e dimostrazioni matematiche, intròno à due nuove scienze in Leiden* in 1638. In the final paragraph of his letter to Elie Diodati, Galileo Galilei presented Roberto Galileo as his relative, to whom Elias Diodati can entrust the contents of the letter; he also mentioned the correspondence with Gassendi and Peiresc, who asked Galileo for telescopic glasses -

lenses. On 25 May 1635, Roberto Galilei passed an interesting letter from Galileo Galilei to Lyon for Nicolas Claude Fabry de Peiresc (1580-1637) and Gassendi. It contained thoughts on the magnetic water-clock of Jesuit Franciscus Linus (Hall, * 1595; † 1675) including Roberto's reading and agreement with the ideas of his relative Galileo Galilei.

The connection between Roberto Galileo (* 1595, Florence) and his cousin Roberto Galilei (* 16. 12. 1615, Florence; † 1681, Ljubljana) is significant. Roberto Galilei (* 16. 12. 1615) used to be the captain for the Istrian fourth part of Carniola, the banker and the salt trader. Ljubljana's Roberto was only nine months younger than the first Carniolan vacuum researcher, Janez Vajkard Auersperg; they often met and worked in mutual businesses. The Florentine origin of Roberto Galileo (* 1615; † 1681) and his kinship with Galileo Galilei enabled his influencing of the Ljubljana society with the help of his wife Sidonia Victoria Baroness Mordax (* 1624; † 1665, Ljubljana). Roberto's position in Carniola was extremely high in relation to the godparents of Roberto's children which included the provincial chief, brother of the first prince Janez Vajkard of Auersperg (* 1615; † 1677). On the other hand, Roberto's wife was, among other things, the godmother of the daughter of Karl baron Valvasor († 1697), the older half-brother of Janez Vajkard Valvasor. Roberto's work in Ljubljana has made a decisive contribution to the popularity of Galileo Galilei's works in Carniola. The Provincial Governor and his brother, the Prince Auersperg, kept the main texts of Galileo Galilei including those which were forbidden in their library in Ljubljana. A few years before Roberto's death, the best friend and librarian of the deceased Carniolan Governor general Volf Engelbert Auersperg, the son of the Mayor of Ljubljana Janez Ludvik Schönleben (* 1618, Ljubljana; † 1681) invited from Salzburg the printer and bookkeeper Janez Krstnik Mayr (* 1634; † 1708). In the autumn of 1678 Mayr did not dare to offer openly to Ljubljana natives the forbidden Galileo's works in Mayr's printed catalog, but he offered equally "dangerous" publications of the Protestant Kepler.

Roberto Galilei of Ljubljana (* 1615) had a brother, a distinguished Maltese knight, at a time when the Bishop of Ljubljana became a slightly younger

Maltese knight Josef Rabata. Roberto Galilei (* 1595, Florence) also had a brother among the Maltese knights. We assume that the concentration of the Maltese knights in Ljubljana helped the defences against Ottomans, with Rabatta and Roberto Galilei actively involved. Galileo's multiple connections with the Maltese knights reshaped his much more troublesome connections with the Jesuits.

Roberto Galilei (* 1615) of Ljubljana descended from a Banking Florentine-Lyon family. He was adopted to the Lyon branch of their family of his older cousin and importer Roberto Galilei (* 1595, Florence). After the Galileo Galilei's process, Roberto (* 1615) was too young in his early twenties to get a sensible engagement in the events and to help his cousin Roberto to conceal the letters of Galileo Galilei in secret. In addition, Roberto Jr. was sent to Carniola shortly after the end of his teens to expand the banking operations of his father Ottavio. Of course, the fateful events following the Galilean process were closely monitored and decisively defined the relationship of the Ljubljana high society to modern science during Roberto's (* 1615) half of a century spent in Carniola.

Roberto Jr. (*1615) was trading with other Ljubljana businesspeople, mainly with traders such as Zacharia Waldtreich and Zergoll(ern). Roberto took over the first devices from Galileo's workshops for Carniolans, which was proven above all for Galileo's analogue computer noted in the legacy of Roberto's Ljubljana host Hans Adam Pettenekh on January 23, 1705²⁷⁶ and in the legacy of Janez Vajkard Valvasor in 1694. Here we would be even more interested in Roberto Galileo's telescope or even the Florentine mercury thermometer, but up to now, unfortunately, the archival data are still silent about those facts. We also do not know for sure whether Roberto or his peer and neighbor, the Prince Janez Vajkard Auersperg, operated a vacuum pump or barometer in Ljubljana.

When he learned of Périer and Pascal experiments, Guericke repeated them with the first useful barometer filled with the water in 1660. The pipe with water reached the third floor of his house, and a

figure in the wood floated in the water as a pointer. The pump was installed on two floors of his house. The neighbors were originally muzzled at the expense of their mayor, who filled the house with strange devices. On a beautiful day, Guericke noticed that the air pressure had dropped dramatically two hours before a terrible storm, and urgently warned his neighbor citizens.²⁷⁷ An exact weather forecast, which is only rarely achieved by modern meteorologists, of course, enabled Guericke's great political reputation. The housekeepers were deeply grateful to him, so next time he was re-elected by a landslide. Today, this could perhaps be said to be a scientifically supported political campaign, which, unfortunately, is not the best established in Slovenian politics.

Guericke also tried to repeat Pascal's barometric experiments on nearby hill, but his servant was far too clumsy and broke the heavy (and costly) barometer which he was supposed to carry.

Boyle and Hooke measured down to 7.9 mbar (6 torr).²⁷⁸ Guericke estimated the pressure at Torricelli's experiment at 13 mbar at the same time. In 1660, Boyle listed the experiments carried out in 1658 and 1659 with the first Hooke's pump, using a mercury gauge in the bell. Thus, several centuries of fruitful competition for the best available pumps and pressure gauges have started. The goal was the lowest pressures that they were still able to exhaust or measure (Figure 4-18).

In 1662, Boyle published his measurements of diluted air pressure in the second edition of his "New experiments" and wrote his findings that we now call the Boyle Law. In 1679, Mariotte independently carried out Boyle-like measurements with decreasing air density at higher temperatures. In 1699, the Frenchman Amontons published the same law for all gases. Most of the later studies of gas laws were carried out in Paris: in Charles' lab around 1787, by Gay-Lussac in 1807 and in Regnault's group lab after 1840.

The "New experiments" together with the other two Boyle books were offered by the bookkeeper Mayr under the title "The Tract on Air" in Ljubljana in

²⁷⁶ SI_AS 309, Legacy Inventory Ljubljana Pettenekh 23. 1. 1705, fascicle 35, box 85, litera P, no. 75, p. 97–98.

²⁷⁷ Sparnaay, 1992, 39; Schott, 1664, 66–67.

²⁷⁸ Redhead, 1999, 137–138.

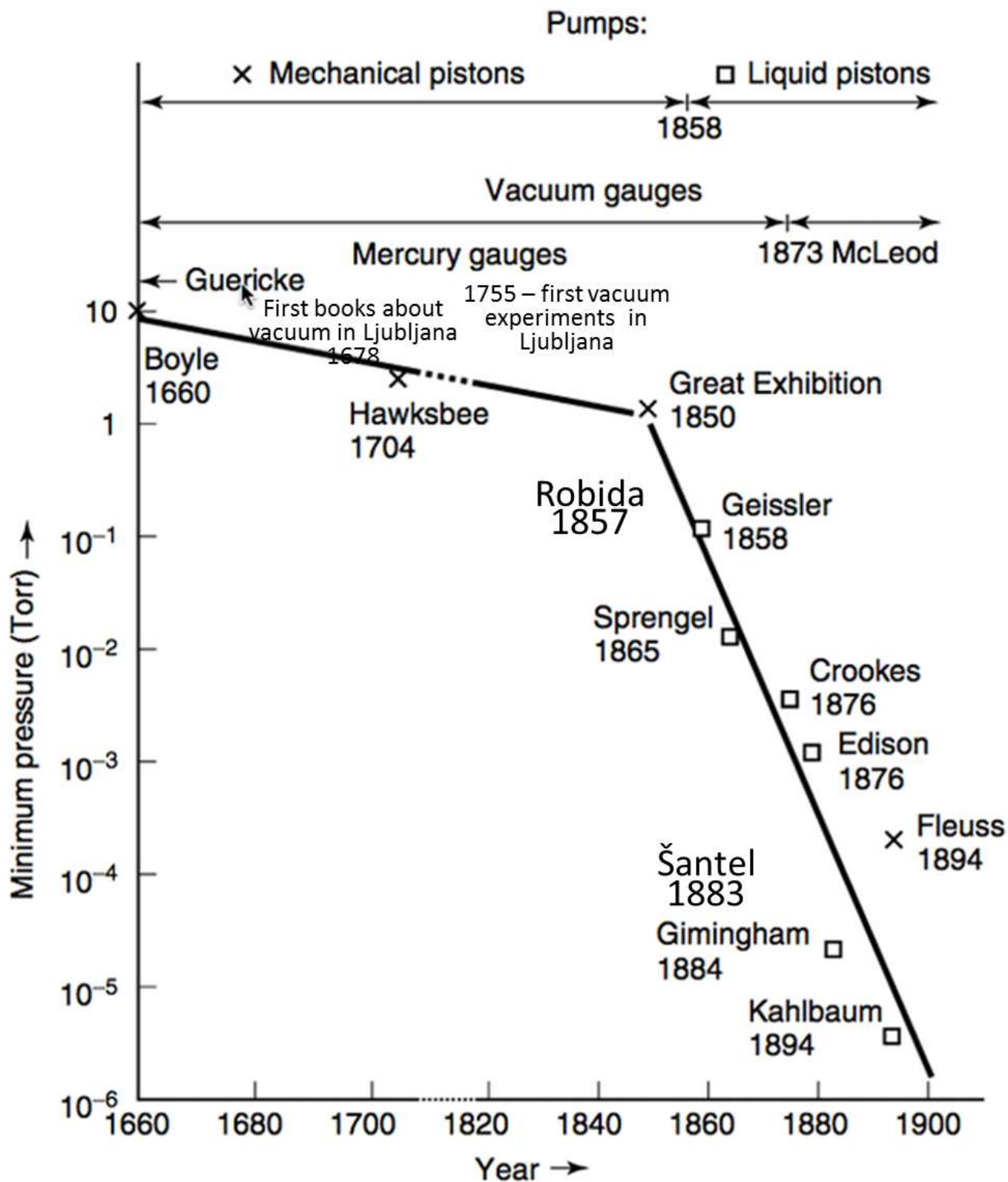

Figure 4-18: Graph of the best vacuum achieved between 1660 and 1900²⁷⁹ with the added achievements in Slovenia and the types of vacuum pumps used

²⁷⁹ Redhead (1999, 142).

1678.²⁸⁰ Boyle tabulated experiments with the rarefication of air down to the pressures of 42 mbar. He rejected Linus' defense of Aristotle against air pressure. According to Linus, the mercury in the barometer is held 0.76 m high by the invisible membrane "Funiculus" from diluted mercury, which we could even touch by sealing the voided vessel with our finger²⁸¹. Similarly, the theory of small "vacuums" that hold the 10 m column of water upright in the pump has already been advocated by Galileo in his interpretation of Heron's experiment, and therefore in their times it was not so unusual or even funny as it seems to us today.²⁸²

achievements advanced in the foreground. Whatever might be inside the vacuum, those tools were industrially useful.

Kircher's student **Franciscus Linus (Hall)** was a Jesuit of English descent, a professor of mathematics at an English college in the Belgian city of Liège. After Cromwell's death in 1658, he was able to return to London for a short visit, but he soon had to return as the unwanted Catholic. He was especially well-known for his controversy against Newton theory of colors, which he published shortly before his death in *Phil. Trans.*

Boyle refused Linus's ideas with a nice trick. By sucking, Boyle lifted the mercury column at the open end of the barometer by 2.2 m higher than on the closed end. Linus did not give up, and he repeated Pascal's experiment, but with the opposite result. He claimed that the height of the mercury column was the same at the top and at the foot of the hill. Of course, there were no particularly high hills around Liège except for Ardennes; in addition, Linus was already approaching his seventies, and he was not strong enough to carry up that heavy mercury anymore. In 1711, Leibniz, Réaumur and others differed in their terms of the decrease in the mercury level in the pipes during the rainy weather. But at the end of the 17th century, barometers for sale were already being manufactured in England, and soon afterwards in Europe. The philosophy of the vacuum was pushed along the side, the technical

²⁸⁰ Sparnaay, 1992 41–44; Hurd, Kipling, 1964, 258–263; Mayr, 1678, 51.

²⁸¹ Linus, 1661; Shapin, Schaffer, 1993, 76, 161–165.

²⁸² Gorman, 1992, 11.

5 Pumps & Maintaining the Vacuums with Getters

5.1 Pumps in the Second Half of the 17th Century

5.1.1 *Guericke and the Research of Vacuum in the German Speaking Provinces*

Guericke carried out his first vacuum experiments in 1640. Eight years later, he put together an early version of the "Magdeburg hemispheres".²⁸³ During the reading of Descartes's *Principles of Philosophy* (1644), he concluded that the controversial existence of a vacuum would be proven by experiments. Thus, Descartes, with his mistakes, encouraged his opponents Guericke, and later even Newton.²⁸⁴

For his first pump, Guericke filled a wine barrel or beer barrel with water, sealed it well and then left the water out through a low-mounted copper tube. The barrel crashed before the water had totally run out. Later, the wooden barrel was replaced by bronze one. In 1650, Guericke assembled an air pump, with which four years later in Regensburg he carried out a famous experiment with Magdeburg hemispheres in front of the Emperor Ferdinand III, Carniolan Auersperg and other princes the electors. He did not use moveable contacts in the form of cones and sleeves. The bronze hemispheres with a diameter of 0.68 m²⁸⁵ was better sealed with a ring made of the skin, which was impregnated by the mixture of wax and turpentine, although sometimes it was sealed with resin. The pull mode was later described as "fast"; as he usually hired two powerful men who emptied the hemispheres in two or three hours, which is not really very fast in today's eyes. Of course, they pumped for good money, which was not lacking in the trustworthy pockets of Mayor Guericke. He used five different large exhausted vessels, the largest was ten times bulkier than the smallest.²⁸⁸

²⁸³ Sparnaay, 1992, 4; Madey, 1984, 11.

²⁸⁴ Hablanian, 1984, 18.

²⁸⁵ ¾ of a yard.

After a successful experiment in Regensburg, many princes wished to buy a wonderful machine. Guericke sold the device to Schönborn,²⁸⁶ who offered him the most. The wealthy buyer was the Prince of Würzburg and Worms and the Archbishop-Elector of Mainz; therefore, it was not hard for him to pay some extra gold coins. He did not buy the pump for himself but gave it to the Jesuits from the University of Würzburg. As early as June 22, 1655 in Mainz, Schott wrote to Kircher about Guericke's device, before taking it over together with the Chair of Mathematics at the University of Würzburg in 1655/56. Schott was a friend and a pupil of Kircher, so he quickly found out what treasure had just fallen into his hands. He began to correspond with Guericke and to publish his achievements. Although Schott was a professor in Würzburg for ten years, not far from Guericke's Magdeburg, we have no testimony to their possible personal meetings. Their different faiths were not the fatal hindrances, as Guericke's son paid a courtesy visit to Schott's teacher Kircher in Rome.²⁸⁷

The first two Guericke's pumps were a reversed fire extinguishers with a bronze cylinder, a wooden piston and a copper sphere, which was used in the second version for a exhausted vessel. In 1657 Schott published the first sketches of Guericke's pumps. At first, he intended to describe hydraulic and pneumatic devices from the Kircher's Roman Museum, and later included other experiments.²⁸⁸ He dedicated his work to Schönborn,²⁸⁹ who, certainly, opened his purse wide to become a great benefactor of early vacuumists. Therefore, of course, Schott dedicated to him another book in 1664, since his professor's salary was not nearly enough to print such large and well-illustrated works.

Schott did not recognize vacuum as something completely void. His friend and patron Dobrzensky Nigro Ponte²⁹⁰ from the established Prague medical family held similar opinions. Nigro Ponte preferred to swear on the mercurial vapors above the barometer. Nigro Ponte criticized the

²⁸⁶ Hellyer, 1998, 265–268; Guericke, 1986, 113.

²⁸⁷ Hellyer, 1998, 280.

²⁸⁸ Grant, 1981, 395.

²⁸⁹ Hellyer, 1998, 268.

²⁹⁰ Schott, 1664, 252, 885.

alchemists, so Carniolan Rain published a book in Ljubljana against him focused on the human saliva and dedicated it to Emperor Leopold I. The clever emperor did not send gold only to Carniolan Rain, but he also supported the opposite books of Nigro Ponte and of Nigro Ponte's model Kircher; of course, they also filled their works with magnificent dedications to the emperor. Unfortunately, the similar emperors, princes or at least elector dukes are now almost completely overlooked so we the modern writers witness much poorer stream gold into our empty pockets, if we do not kindly get help from any ministry. In 1662, using the Boyle's early work, Guericke composed the third version of his pump nicknamed "Reiseluftpumpe". It happened be without the disadvantages of the first two designs. He used a leverage system for pumping in the manner of reversed manual fire extinguisher, which was supplemented with a valve on the lid and reduced the volume of the exhausted vessel. Instead of water, he directly pumped out air, which was one of his most important novel contributions to vacuum technology. Three original Guericke's products are kept today at the Technical College of Braunschweig, the Technical Museum in Malmö and at the German Museum in Munich.²⁹¹

On 14 March 1663, Guericke completed seven parts of his book, which was only published a decade later because of his overemployment and occasional diseases. Although the Auersperg prince had already felt into imperial disgrace during this time, Guericke published a detailed description of their mutual research of vacuum. With this, the Early Carniolan science set up a magnificent monument, which modern Slovenian vacuum researchers are proud of. Guericke used their devices as "syringes", "*Antlia Pneumatica*" and in 1662 "Reiseluftpumpe". Boyle baptized his pumps for "pneumatic machines". The names such as the air and vacuum pumps were established later. Schott and Guericke criticized the usefulness of Hooke and Boyle's pumps, and the brave Englishmen made their good returns with heavy interest. Part of the criticism came from poor information; Hooke and Boyle knew only the first version of Guericke's pump from Schott's book. Schott and Guericke considered that the pump of their colleagues beyond the English Channel was badly sealed as they were not informed early enough of Boyle's improvements. Nevertheless,

they occasionally borrowed ideas from each other for individual parts of the pumps without considering much of the copyright. Just for his experimental facilities, Guericke used up 20,000 Thalers; at least so narrated his son, who spent the last five years in Hamburg. Guericke's work divided in seven books was not published until 1672. The Amsterdam printer did not pay Guericke's honorarium, but after painful negotiations delivered only a few copies of the book to Guericke.²⁹²

The first vacuum experiments have not yet yielded promising profits, but they harvested plenty of honor. In 1666, Emperor Leopold I elevated Guericke to the noble ranks, so he was proudly signed with the adjective "von". The Almighty Auersperg prince supported the advancement of his friend Guericke, although he was no longer as proudly honored by his new emperor, as he used to be by Leopold's imperial father and brother in his better time.

5.1.2 *Auersperg, the First Carniolan Vacuum Enthusiast*

5.1.2.1 Auersperg and Guericke

Three and a half centuries passed after the famous Guericke's experiment in the Bavarian Regensburg. On the banks of the Danube, the spark-horses pulled out two semicircular discharged hemispheres on each side: without success, but with a big pomp. Only a decade ago, Torricelli and Viviani put together their barometer; but the Florentine academics did not promote their invention on the big bell in fear of a possible repetition of Galileo's condemnation. So, a lot of water has passed before Carniolan Idrija miners started selling much of their mercury for barometers. Only Guericke, Carniolan Auersperg and other great men first publicly discussed vacuum experiments in Regensburg. The validity of scientific assumptions and experiments was judged by the then educated nobles who were accustomed to solving technical problems while they swunged their swords during the thirty years of war. Regensburg and Carniola were parts of their common Holy Roman empire at that time and a century and a half later. Since Carniolans were

²⁹¹ Schneider, 1986, 398–399.

²⁹² Guericke, 1986, 109; Shapin, Schaffer, 1993, 277–278.

always the right people in the right places, we should not be surprised that they have significantly interfered with the very beginnings of the vacuum technique. The state gatherings were meetings of the Central European cream that could not pass without a joyful Carniolan nobility. The Gottschee (Kočevje) landlord Ivan baron Ungnad was the adviser to Emperor Ferdinand I at the National Assembly in Regensburg in 1546. Later, he became the most prominent supporter of Primož Trubar together the Auersperg family. The provincial Governor Janez Cobenzl from the Predjama castle near Postojna joined 15000 followers of Emperor Rudolf II, the grandson of Ferdinand I, at the National Assembly in Regensburg. Unfortunately, he died there and never saw his homeland again. He was the grandson of the famous Carniolan Robin Hood, Erasmus of Predjama (Lueger, † 1484), and the father of the Jesuit mathematician Janez Rafael Cobenzl. Janez Rafael learned modern science from Grienberger, Clavius' successor at the College of Rome. In 1626 and 1627 he was an adviser to the Austrian provincial and the Rector in Vienna where he significantly influenced the education of one of the heroes of our story, Janez Vajkard Auersperg (* 1615).

In 1653 and 1654, Carniolan nobles attended a gathering in Regensburg. The most important among them was newly inaugurated Prince Janez Vajkard Auersperg (Figure 5-1). He was the great-grandson of the famous military leader, Baron Herbert Auersperg, who bravely fell under the Turkish sword, and the grandson of his eldest son, Kristof. He was born as the fourth of five sons of hereditary Marshal Ditrih Auersperg. Ditrih inherited the Žužemberk castle after a fire that destroyed the building during the Easter celebration in 1591. In 1631 he bought the nearby manor Vrhkrka, which his son Janez Vajkard inherited after his death. In 1625, Dietrich (Ditrih) among the last Carniolans returned to the bosom of the Catholic Church. At that time, he bought two houses at the crossroads of Gosposka and Turjaška ulica (street) in Ljubljana, which he rebuilt in 1631 and 1632. On 16 September 1630, he became the imperial count and his sons inherited that privilege. Thus, Carniolan hero Janez Vajkard spent his youth and the first school years on the same street opposite the provincial house, where the other two Carniolan princes and the Viennese ministers Eggenberg and Portia also lived. Portia was

married to the first cousin of Janez Vajkard, so that alongside the neighborhood ties they added their marriage connections. Between 1635 and 1650, Portia was a provincial judge in Carniola, then became "ajo", the highest court master and educator of the young Emperor Leopold. Together with his relative, the prince of Auersperg, they raised both Emperor's sons and brought them up with Carniolan wisdom. Naturally, after his enthronement, Leopold I gave much more confidence to his former educator Porta.



Figure 5-1: Auersperg Prince Janez Vajkard (* 1615; † 1677) in his younger years.

Ditrih's oldest son, the Count Volk (Wolf) Engelbert Auersperg, bought the Kočevje and Poljane domains on July 9, 1641, and after a few months he continued with his father's constructions in Ljubljana.²⁹³ In 1649, he became a regional leader Governor General, and next year he built a castle on the edge of the then town of Kočevje. On 20. 4. 1660, he began to build near his father's northern half of the "princess castle", on the southern part of today's Plečnik's NUK in Ljubljana. There he staged the opera according to the Venetian example. He completed the construction in two years. Near the Duke's Castle, the first cousin of Volk Engelbert, the Count Janez Andrej Auersperg from Turjak, brought together three buildings for his new Auersperg Count's

²⁹³ Mal, 1925, SBL, 1: 19.

Palace at Gosposka and Križevniška Street between 1654 and 1659. Today, there is the Municipal Museum on Gosposka Street no. 15. Thus, the Auerspergs of Kočevje and their relatives of Auerspergs of Turjak, lived in magnificent buildings in the middle of the New Square, which became the provincial administrative noble part of Ljubljana. The count Volk Engelbert decorated his mansion with the richest noble library at the then Carniola, which his ancestors began to collect on the Auersperg castle in the 14th century. Meanwhile, his younger brother, Janez Vajkard, led the politics of Emperor Ferdinand III who was educated by the Jesuits as a capable linguist and composer of church music. When Janez Vajkard completed his studies at the aristocratic colleges, the Emperor entrusted him with the education of his oldest son the crown prince Ferdinand IV. In 1637, Janez Vajkard became a courtier. Two years later, his elder brother Herbert Auersperg joined the Viennese Spanish court of the Empress Maria Anne of Spain. Herbert Auersperg married baroness Moscon from Krško near Šrajbarski Turn in 1649.

On 7. 9. 1653, the Emperor promoted Janez Vajkard to the great rank of state prince. The ceremony was staged at the National Assembly in Regensburg, three months after the crowning of the crown prince Ferdinand IV. Janez Vajkard got to the fiefdom county Wels in Upper Austria. The following year, the emperor gave to Janez Vajkard the Silesian principalities of Münsterberg (Ziębice) and Frankenstein (Ząbkowice Śląskie) which belongs to the Polish Sudeten today. Carniolan Janez Vajkard became a secret councilor, a golden fleece knight, a conference and state minister. His rival, Lobkowitz, at the same time received the title of a secret councilor and, together with Portia, spearheaded the imperial foreign policy. The popular successes of Janez Vajkard were crowned with his personal ones. On November 20, 1654, he celebrated a cute wedding with a countess from the Losensteiner castle at Steyr in Upper Austria. Her father, a courtier count Jurij Ahac, died during the assembly in Regensburg, two months after his future son-in-law got the title of prince. Soon the funny old death picked up Jurij Ahac's wife, the noble Mansfeld. Of course, their very poor orphaned daughter was quickly comforted by Carniolan great prince, while the couple gave birth to their eight children. The Carniolans were worth their money.

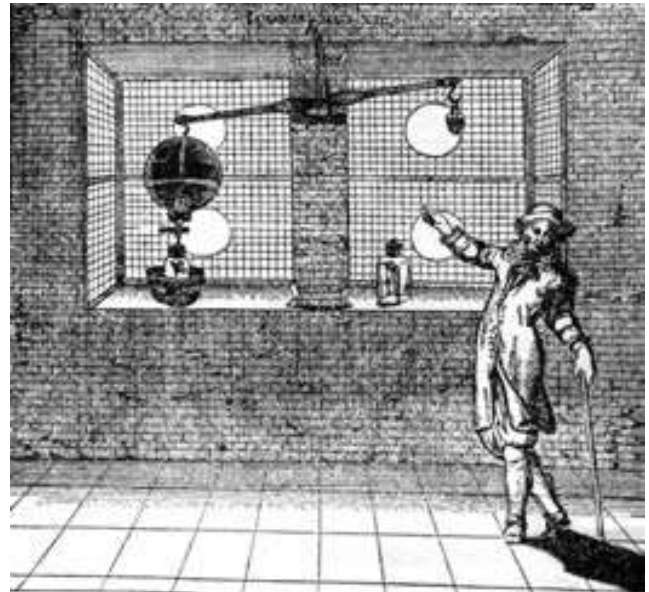

Figure 5-2: An experiment which Guericke pointed to the Auersperg prince in Regensburg in 1654.²⁹⁴

The origin of Guericke's family lacked Auersperg's noblesse. He was born in the family of officials and patricians who lived in Magdeburg since 1315. Among his ancestors, there were as many as thirteen mayors. He studied philosophy and law at universities in Leipzig, Helmstedt and Jena. He completed his education at Stevin's Engineering School in Leyden, then expanded his horizons with journeys across England and France where he met Boyle and Pascal's networks. After returning to his native Magdeburg, during the Thirty years of war he began to work in politics in 1626, and after twenty years he became one of the five mayors in the city. In the meantime, he spent a lot of dreadful hours, especially after Marshal Tilly took over the command of the Imperial Army in 1630. On May 20th, 1632, Guericke successfully escaped from the burning Magdeburg only because his father-in-law was in contact with Tilly's officers; Tilly's have given their fatal swords as final presents to the two thirds of the thirty thousand Guericke's fellow citizens. Bosnian Srebrenica is by no means a novel invention.

The Protestant Guericke served as an engineer in Swedish and then in the Saxon army during the war.²⁹⁵ Despite his understandable resentment towards Tilly, he co-operated with his Emperor Ferdinand III, who personally assumed the command of the army four years after Tilly.

²⁹⁴ Guericke, 1986, 76.

²⁹⁵ Hellyer, 1998, 279, 280.

Guericke was representing the benefits of his city at the Osnabrück conference, where between 1645 and 1648 those funny folks finally agreed on peace after a thirty-year war. There he met Janez Vajkard Auersperg, who attended the conference in the Embassy of the Emperor. They saw each other again during Guericke's visit to the Viennese court.²⁹⁹ The inventive Guericke already wanted to report on his vacuum experiments at that time.

Guericke attended the National Assembly in Regensburg as a full-fledged politician. He presented to the Emperor and prince his experiments with air pressure and told about new, barely discovered phenomena. He ensured the doubtful nobleman that the atmosphere above us presses on all hollow bodies that are not completely fully filled with wood, stones and similar substances. The air fills all the voids; but if it does not, it presses the empty containers to transform them.

The clever mayor was first weighing his air, which would still be considered today for a wasting of time. He equilibrated his balance with a vacuum container on one hand and with the weights on the other side. After he emptied his container, he found that some weights needed to be removed on the opposite side to retain the balance (Figure 5-2).

In the second experiment, the quadruped container was exhausted and sealed with a valve. The container did not withstand the external pressure and it collapsed in a thousand and one piece with a sharp crack. The circular vessel did not burst in a similar experiment, because it was not so easily deformed by the external pressure. Guericke told Emperor Ferdinand III, King Ferdinand IV, Auersperg and other princes about his experiments in an empty space, and by the way he mentioned that we run out of air when we blow into vacuum container. He knew that many dangerous things could happen to us, since the external pressure does not only squeeze out all the air from the human or animal body into a exhausted vessel, but even damages the body with the gut included. Because of pressure, we can even die. The Auersperg prince did not believe much in the empty words: he demanded an experimental proof. He was not prepared to abandon Aristotle's science from his student benches, where the vacuum seemingly opposed any common sense. Even the recently deceased Descartes did not approve total

emptiness. The Carniolan noble Auersperg wanted to examine the circumstances in an exhausted vessel. The Auersperg prince was then in his thirty-nine year of age and was almost more powerful than the very old emperor. The doubts of the powerful prince had questioned all other Guericke's experiments. It was a question of personal prestige: will Guericke convince the prince of the validity of his considerations? The engineer Guericke was not particularly at home in Aristotle's logic, and he did not want to go into discussions about the nature of the vacuum, which was often blown by his rival Boyle beyond the English Channel. In an empty space, he saw a useful utility for the propulsion of machines; only two years after Guericke's death, Denis Papin fulfilled those ideas after he took over the chair of mathematics at the University of Marburg, 250 km southwest of Guericke's Magdeburg.

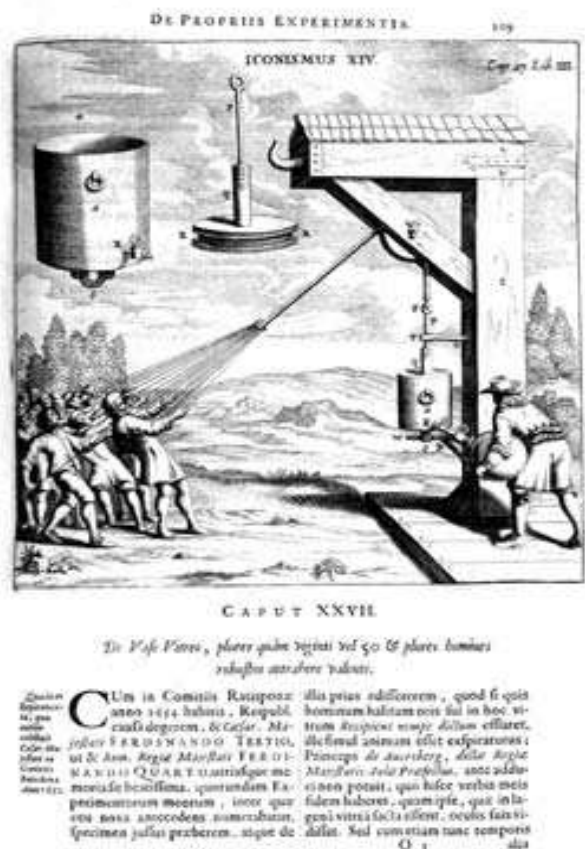

Figure 5-3: This is how Guericke persuaded the Auersperg prince that the vacuum really existed.²⁹⁶

Guericke avoided a scholastic dispute with Auersperg and left the decision to his experiments.²⁹⁷ To remove doubts from his

²⁹⁶ Guericke, 1986, 78.
²⁹⁷ Hellyer, 1998, 280–282.

demonstrations, he hired twenty, thirty and finally hundred people who could not lift the lid off the empty exhausted vessel (Figure 5-3).²⁹⁸ He calculated that the air pressed on the lid with a force of 13 kN, which thirty or even fifty men could not overcome. Apparently, he did not deal with the especially strong guys.

Guericke then replaced his hired people with weights and thus weighed the air pressure.²⁹⁹ To the Carniolan prince and other surprised grand magnates Guericke showed how the vacuum "pulls" water up the tube, extinguishes the candle and suffocates the ticking of the clock. To the lovers of grapes and its processed forms, which at that time were not lacking and are not lacking even today, he served a very welcoming news: "Finally, it should be mentioned at this point: when we place the grapes in such a glass container, we empty it and then store it in a cold place for half a year, the grapes' appearance will not change, but they will lose all the juice." He explained the success of the vacuum preservation: "From here, it follows that the juice escapes into the empty space is evaporated, while otherwise it would return backwards and remain in the interior due to the pressure of the surrounding air."³⁰⁰

All that was not enough for the vile Auersperg. As a genuine knight of his time, he wanted to resolve the plot with an empty space, as it is suitable for the grandson of the commanders of the Habsburgian armies. The cavaliers of the knights' tournaments mostly trusted their sparkling sparrows; therefore, they ordered to their horses resolve the vacuum puzzle. The assembly in Regensburg was boring, so every party was welcome. The Magdeburg hemispheres experiments were the summit of several months of debates and experiments in Regensburg. The expectation was gigantic, the enthusiasts even bet on that or the opposite side. The emperor himself, Auersperg and other elector princes extended their stay in the city to see what Guericke's horses would do.³⁰¹ Preparations for the first large, luxurious event in history have raised a lot of dust but the clever Guericke dwindled all opposition after he had precisely recalculated all the conditions regarding the surface and diameter of

the spheres and the number of horses needed (Figure 5-4).³⁰⁷ Let's ensure that Carniolan Auersperg would not be able to find some problems again! The calculations convinced Guericke that, God forbid, the horses will in no way be able to disassemble the hemispheres when the air is exhausted from the space between them. Certainly, the pressure was almost twice higher than the power of horses. Auersperg, of course, was equally well prepared by preventing Guericke's eventual cheating by any helpless old horses.

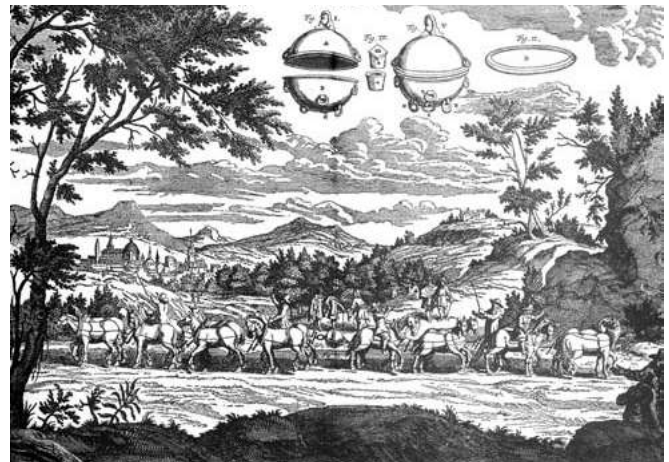

Figure 5-4: An experiment with Magdeburg's hemispheres, which Auersperg's saw in 1654 in Regensburg.³⁰²

Then horses dragged, dragged ... Finally, the wide-eyed hats of many curious people, princes and with a slight delay, even the Auersperg's hat itself flew into the air. The Magdeburg mayor won. The last doubter had to admit that they were witnessing a new chapter in physics. Of course, many spears have been broken during next half of a century over the explanations of vacuum phenomena with empty space, air pressure, invisible filaments or vapors. The vacuum entered the Central European High Society in a particularly magnificent way, under the critical eye of Carniolan Auersperg prince.

5.1.2.2 Auersperg Prince in a Political Vacuum

The news of the Magdeburg hemispheres quickly swept Europe. On 22 July 1656, Guericke reported to Schott about the experiment with copper hemispheres in Regensburg (Figure 5-4).³⁰³ The Prince addressed the Emperor to invite Guericke to

²⁹⁸ Guericke, 1986, 77.

²⁹⁹ Guericke, 1986, 80.

³⁰⁰ Guericke, 1986, 49–50.

³⁰¹ Hellyer, 1998, 266.

³⁰² Guericke, 1986, 68/69; Schott, 1664, 38.

³⁰³ Schott, 1657, 460; Schott, 1658, 604; Schott, 1664, 18, 39.

Vienna. A famous experiment with horses that in vain tried to separate two hemispheres held together only by air pressure was repeated by Guericke at the Emperor's Viennese Palace in 1657, shortly after the death of Emperor Ferdinand III. The strong Carniolan horses Lipizzaners were encouraged by the most beautiful ladies of the Empire, but they did not split the hemispheres. The Carniolan prince was already for a long time the top guy in the imperial city. His protégé the king Ferdinand IV soon got his fatal smallpox pest and died. The throne was taken over by his younger brother Leopold I, whom the Jesuits had so far educated for church services. He was still young, and therefore, he was led by Auersperg, his adviser and the first minister. The Emperor and Prince, under Guericke's influence, became interested in vacuum technique, so in 1658 they visited Schönborn, Schott and the Jesuit College in Würzburg.³⁰⁴

After the printout of *Oedipus* (1658) Janez accompanied the new Emperor Leopold I. The emperor Leopold I and Janez visited Schönborn and Schott's Jesuitical college in Würzburg in 1658.³⁰⁵ Schönborn grew up in a mixed family full of religious tolerance and was hoping to unite both churches. He codesigned a League of the Rhine River for the French king against the emperor.

During the year following the death of Ferdinand III the Parisian first minister the Cardinal Mazarin obstructed the election of Leopold I for the Emperor until Lobkowitz, collaborator and rival of Carniolan Prince Janez Vajkard Auersperg, convinced Schönborn to give his vote for Habsburgian at the state council. Auersperg's rival Wenzel Lobkowitz addressed and talked over Schönborn to give his own votes to Leopold I, and thus transferred the scales to gain the Imperial title in Leopold's favor. Schönborn's vote was vital as only eight eligible voters participated in the elections of new emperor. The electoral prince and Archbishop of Mainz (1642-1673), Würzburg and Worms Prince-Bishop Johann Philip Schönborn have agreed to give his (both) votes to the Leopold's election. These (two) votes have decisively stopped conspiracies for the election of the Bavarian candidate. That success, despite the lord protector Oliver Cromwell's (1599–1658) and

Mazarin's conspiracy favouring the Bavarian prince-electors Ferdinand Maria (1636-1679), however, rearranged scales of eight appointed electors. Leopold got imperial title at the coronation in Frankfurt am Main on August 1, 1658. The archbishop of Mainz Johann Philipp von Schönborn performed the coronation as Frankfurt was in his province of Mainz. The probable freemason Oldenburg also attended that fest of coronation while he served as a home teacher and travel companion of R. Boyle's nephew Richard Jones; Oldenburg has certainly met Prince Janez Auersperg there even if the number of people attending was huge. Katherine Jones viscountess Ranelagh's (1615-1691) son Richard Jones (1641-1712) 1st Earl of Ranelagh FRS, known as the Viscount Ranelagh between 1669 and 1677, was an Irish peer, as well as politician in the Parliaments of England and Ireland. Robert Boyle spent his last almost quarter of century in his sister Katherine Jones' household in Pall Mall in central London while Oldenburg also lived and died in the same street with his own wife. In that way, Robert Boyle could indirectly exchange his experience of pumping of the air with Guericke's former assistant Prince Janez Auersperg. Later, Oldenburg and his protégé somewhat bisexual Richard Jones rode to Mainz and met a promising young erudite Becher.³⁰⁶ A decade later Oldenburg has drawn up detailed instructions for the visit of Edward Brown (* 1644; † 1708) in Carniolan and nearby lands in 1669: Brown's travelogue was also published in Oldenburg's *Philosophical transactions* of RS³⁰⁷ but Valvasor was not particularly impressed and he criticized Brown's narrations as the allegedly better informed native.

On 6 September 1660, the prince traveled with his wife across the Alpine Ljubelj and arrived in his brother's Ljubljana's mansion. There they prepared a reception for the Emperor, who came to White Ljubljana for a hereditary homage during the following day. Between 18 and 24 September 1660, the ceremony was repeated in Gorizia, where the Jesuit Baučer spoke as the first historian of Slovenian origin. In 1663, the Auersperg prince bought the County of Thengen in then Upper Austria (later Tengen in Baden) and made it the princely manor with his purchase. He preferred to relax in the forests of Carniola. That is why, the Prince bought the Carniolan manor Pazin in Istria

³⁰⁴ Hellyer, 1998, 100.

³⁰⁵ M. Hellyer, Jesuit Physics, In: *The Jesuits cultures, Sciences, and the Arts 1540-1773*. 1999.

³⁰⁶ M. Boas Hall, *Henry Oldenburg*, Oxford 2002, 34, 36.

³⁰⁷ Šumrada, 1989, 56.

on 18 June 1665. In the following year, Paz and Krašan in neighborhood joined his Pazin. The prince and his brother Volk Engelbert each bought a half of Belaj near Paz, 15 km east of Pazin. However, the days of the harmony between the prince and the increasingly independent new emperor passed. Carniolan Auersperg wanted a cardinal hat, which, unfortunately, very rarely adorned the Carniolan head. He did not even inform the emperor about his negotiations with the Papal headquarters. At the same time, he tried to change the foreign policy of the Habsburgs who opposed the French during the thirty years war and after that. This was not possible during the time of Italian Mazarin, who won the cardinal hat in 1641, and the chair of the first Parisian minister two years later. Mazarin took care of French domination in Europe and despite the death of Ferdinand III hampered the election of Leopold I to the post emperor until Lobkowitz persuaded Schönborn to vote for Habsburg. A year after the death of Ferdinand III the Parisian first minister the Cardinal Mazarin obstructed the election of Leopold I for the Emperor; until Lobkowitz, collaborator and rival of Carniolan Prince Janez Vajkard Auersperg, convinced Schönborn to give his vote for Habsburg at the state council and thus influenced game for the Imperial title in Leopold's favor.

The angry Nikola Zrinski (d. 1664) with his brother Peter and his brother-in-law Franjo Frankopan announced to the National Assembly in Regensburg (1663-1664) his intension to seek a new ruler if Leopold will not protect the Croatian interests under the current unfavourable Peace of Vasvár (Železnograd). However, Auersperg's and Carniolan nobility remained deaf to that mutiny conspiracy invitations for the rebellion except for a Styrian Ivan Erasmus Tattenbach (1665) and Gorizia chief Karl Thurn (1668).³⁰⁸

After Mazarin's death and a benevolent Habsburg peace agreement with the Ottoman Turks in Vásvar on August 10, 1664, Auersperg felt that the time had come for a reversal. He had a lot of promises from Mazarin's successor the lover of books Colbert, who in 1665 became the chief controller of French finances and in 1669 the naval minister. The French ambassador to Vienna between 1664 and 1673, the General Lieutenant Colonel Grémonville, completely mastered the

Viennese diplomacy of Lobkowitz and Auersperg. In addition, the Emperor Leopold I was in close kinship and friendship with the French king. Despite the unexpected French occupation of Belgium on 26 May 1667, a few months later, the emperor concluded a secret agreement for the possible division of the Spanish heritage with the Sun king Ludvik XIV on 19 January 1668.

After the death of Auersperg's relative Portia (Porcia), Lobkowitz assumed the position of the first counselor at the court. The prince Auersperg's alleged secret negotiations with French diplomats and the Pope came to the Emperor's ear. The emperor could hardly wait to get rid of his father's former protege with his annoying patronizing. At the request of the Spanish court, the emperor pushed Auersperg in his early retirement in 1669 and sentenced him to death for the sake of his alleged betrayal. The French were of course surprised, as their negotiations with the Auersperg did not go beyond the boundaries of conventional diplomacy. The plot grew up mainly as a master minded hoax of Auersperg's opponents. In any case, the frightened Auersperg hid himself in Venice for two years and waited for more pleasant winds from Vienna.³⁰⁹ Of course, his hosting at the hostile dodge's networks did not bring him the love of the Viennese rulers; nevertheless, he was forgiven by the benevolent emperor who "only" banned him from the court.

The new first minister and director of the cabinet became Lobkowitz. An obtrusive Auersperg was dismissed after his premature deals. Lobkowitz soon rolled the policy into a short-lived Catholic alliance with Paris and Madrid. He retained the position of the deposed Auersperg prince until 1674 and died only a few months before him. After Auersperg's departure, Leopold I double-crossed the French candidate for the succession of the Polish King Jan Kazimierz. On 19 September 1669, the Polish "Szlachta" convinced with a good strong drop elected the Habsburg candidate Wisniowiecky (Mykolas I Kaributas Višnioveckis; 1640-1673). Of course, in the following year, he married Leopold's half-sister, Eleanor Maria, in a brilliant ceremony. Grémonville and the angry French MPs searched for allies among Hungarian conspirators, but their plans came to Lobkowitz's ear. The conspiring princes, Frankopan and Zrinski, voluntarily surrendered to the Viennese in

³⁰⁸ J. Škofljanec, *Observanti*, Ljubljana 2008, 67-68.

³⁰⁹ Note of Dr. Janez Šumrada on 9. October 2003.

April 1670, only a few months after the Auersperg's fall. The Croats did not get Auersperg's support and they were decapitated after a year-long hearing. Among the plans of the Zrinski-Frankopan conspiracy was the penetration of eight hundred conspirators led by the Brod na Kupa parish priest Juraj Prpinić across Kostel to Kočevje, where they hoped in vain for the support of Auersperg after the prince's dispute at the court.

The aggressive Colbert's Dutch trade policy forced enlightened Habsburgian emperor to take his action with countermeasures. In 1671, the French and Habsburgs signed a treaty of neutrality. The following year a Dutch war broke out, the first of three wars between Louis XIV and Leopold I.

5.2 First Carniolan Vacuum Researcher: Books on the Vacuum of the First Ljubljana Vacuum Researcher

5.2.1 Introduction

Modern vacuum technology began to develop when the mercury barometer and vacuum pumps were invented three and a half centuries ago. The basic ideas were probably Galileo's, and their performance involved at least seven stronger research groups, which were often very able but suffered in permanent mutual quarrels:

- The Galilean Circle around the Academia dei Lincei in Rome and then with Torricelli and Viviani's Florentine Academia del Cimento;
- Athanasius Kircher's (* 1602; SJ; † 1680) circle in Rome that began to flourish with Gaspar Berti (* about 1600; † 1643) in 1640 in a company with Torricelli, Nicoló Zucchi (* 1586; SJ; † 1670) and Gaspar Schott (* 1608; SJ; † 1666);
- Valeriano Magni at the court of the Polish king and in Regensburg (1654);
- Robert Boyle in Oxford and London with assistants Robert Hooke, Denis Papin and Francis Hauksbee (Huxbey, Hawksbee, * 1660; † 1713) in connection with the Royal Society experiments of Henry Power (* 1623; † 1668) in Halifax on 6/5/1653;

- Otto Guericke in Magdeburg in connection with the Prince of Ljubljana Janez Vajkard Auersperg in Regensburg (1654), then with Prince Philip von Schönborn (* 1605; † 1673) and Jesuit Gaspar Schott in Würzburg;
- Blaise Pascal's circle in Rouen and Paris with Florin Périer (* 1605; † 1672) at Clermont-Ferrand in the Auvergne region (1647) alongside with Mersenne's Parisian visitors like Etienne Noël (* 1581; † 1659), or even Descartes, followed by Henri Louis Habert de Montmor's (* about 1600; † 1679) Parisian group with Huygens in The Hague as the forerunner of the Parisian Royal Academy of Sciences;
- Londonese Franciscus Linus (Hall, * 1595; SJ; † 1675) in the Belgian Liege in 1661

Vacuum experimental innovations were spreading extensively across Europe devastated in the wilderness of the Thirty Years' War. White Ljubljana was by no means exempted: Slovenian vacuum technology can be traced through the paths of the main protagonists of vacuum research related to Janez Vajkard Auersperg's purchasing the main books on vacuum or testing vacuum devices. Most of the mercury of early vacuum researchers was mined up in Carniolan Idrija.

Among Carniolan compatriots, the most prominent was the Prince of Ljubljana, Janez Vajkard Auersperg, who arranged the Emperor's invitation for Guericke's Viennese visit; Janez was closely involved in the design of Guericke vacuum experiments in Regensburg in 1654. Guericke repeated his famous experiment with horses, which in vain tried to separate the hemispheres of emptied receivers in the court of Vienna shortly after the death of Emperor Ferdinand III in 1657.

Our prince was by far the most powerful in the imperial city of Vienna, where all those less wealthy had to leave the belly outside. The emperor Leopold I and Janez visited Schönborn and Schott's Jesuitical college in Würzburg in 1658.³¹⁰ Two years later the emperor in pleasant company of the empress moved to Ljubelj on 13 September 1660 and rode to the castle of Janez's brother, Volf Engelbert Auersperg, to get his bows of obedient inheritance from Carniolans. The Ljubljana Imperial visit was prepared by three

³¹⁰ Hellyer, 1998, 100.

brothers Auersperg: Janez Vajkard was the first minister in Vienna at that time, and the older brother Count Wolfgang Engelbert was the provincial chief of Carniola; also, their middle brother was not lagging behind, as he was the commander of the Karlovac Military Krajina Herbert from the Šrajbarski Turn near Krško. Herbert brought 150 knights from Karlovac in folk costumes accompanied by two whistlers and two drummers.³¹¹ The unusual eastern colored music by the Auersperg palace was a pleasant view for eyes of everybody including the high society. For his emperor, Volf (Wolf) staged one of the first Ljubljana performances of the Italian opera at the time. The imperial messenger Lovrenc Kurelić (Churelichz) reported about the Italian Commedia and musica at Wolf's Garden, and later Valvasor noted it in his masterpiece *Die Ehre (Glory)*.³¹² Naturally, Valvasor watched enthusiastically and then painted the nice cavalry show in honor of the Emperor's visit. Unfortunately, we do not know whether on this occasion even the famous Guericke's "horse" vacuum experiment was taken to Ljubljana.

The happiness is never eternal and soon after that, Janez's luck began to decline. On December 10, 1669, they ordered him to leave Vienna within three days; the court intrigues pushed him from the sky above the empty space roughly against the solid ground! He had to go to his estate in Wels, and later he was permitted to return to his native Carniola.³¹³ In April 1670, the secretary of the academy del Cimento, the Count Lorenzo Magalotti of Tuscany (* 1637; † 1712), reported in Florence about the incessant attempts of the president of court chamber the Count Johann Quentin I Jörger Tollet (1624-1705) of the golden fleece order to arrange the return of Auersperg to the Viennese court.³¹⁴ The publication of Magalotti's letters was later purchased by the Jesuits of Ljubljana. The people of Ljubljana were left without a prince's prevalent word overnight in Vienna: how did they appropriately acquire knowledge of the modern vacuum experiments, the leading entertainment of the days?

During the development of their Ljubljana "prince" library in the middle of the 17th century, the Auersperg brothers were the most important in Carniola, often the first after the Habsburg rulers themselves. Such highest position was retained three centuries later. It is therefore particularly important to know by which ways and tools they advocated the advancement of experimental techniques and especially vacuum experiments in areas inhabited with Slovenians. Of course, the best example of their efforts is the Auersperg Ljubljana Prince's Library, which was placed in their Baroque palace around the premises of today's NUK and kept the best private collection of books in Europe. In the 1668 catalog, rewritten in 1762 on 431 pages, there were as many as 3257 books in 6000 to 7000 volumes;³¹⁵ many of them were devoted to the problems of vacuum. The Auersperg's Library catalog has long been considered a lost one until it was found in Vienna by dr. Matija Žargi and kindly made available to the author of this book.

5.2.2 *Galileo and Kepler's Ideas in Auersperg's Networks*

Janez Vajkard Auersperg completed his studies in Siena in 1635 in the class of mathematician and architect Gallaccini. During his research of the vacuum Gallaccini was referring to the book of Benjamin Bramer, so he also directed Auersperg's thoughts to Bramer.

The most important Auersperg door for modern science were, of course, two thick parchment-bound books of Galileo's collected works in the first Bologna Manolesi edition from 1656. The edition classified Galileo's works chronologically. It began with Galileo's proportional compasses as an ancestor of an analogue computer, which Auersperg also acquired in an older edition. This was followed by a Galileo's defense in the conflict of interest involving the falsely claimed invention of Capra (1607), which was in Ljubljana and certainly in many other libraries bound together in the same volume with the book about Galilean Proportional compass' drawing tool. After that paper, Manolesi published the second edition of Galileo's Paper about Water with numerous defenses against criticism. The first book was completed with *Mechanics and Libra*. The second

³¹¹ Steklasa, 1881, 741.

³¹² Höfler, 1978, 126; Radics, 1912.

³¹³ Sienell, 2001, 87-91, 96, 103; Mecenseffy, 1955, 71-74.

³¹⁴ Seifert, 1988, 56.

³¹⁵ Radics, 1878, 14.

book was launched by the Star Messenger, who brought fame to Galileo in 1610. Behind it, the editor added Sunspots, Comet from 1618, disputes with the Jesuits Scheiner and Grassi in various letters and finally the Discorsi with the foundation of the later Torricellian vacuum experiments.

Theophilus Gallaccini (* 22. 9. 1564 Siena; † 27. 4. 1641 Siena) was the son of poor respectable noble parents. At first, he devoted himself to philosophy and medicine and received his doctorate in Siena on 19 June 1583. He returned to Siena from Rome in 1602 and married a local beauty. In 1608 and 1609 he taught mathematics instead of Francesco Pifferi (* about 1548 Monte San Savino in Tuscany; O.S.B. Cam; † after 1604). In 1621, Gallaccini became a university professor of mathematics. After the death of the famous Guglielm Gangioli, Gallaccini also took over his lectures of logic and philosophy. His book on the architecture of ports, and his manuscripts on architectural theory were only printed in 1767. Gallaccini was very close to Galileo in his mathematical surveys, especially after Galileo's visit to the Sienese bishop in August 1633, immediately after the process in which Galileo was sentenced in Rome. Janez Vajkard Auersperg arrived in Siena a little later.

Manolessi did not include the disputed Copernican Dialogues of 1632 despite the death of Pope Urban VIII (Maffeo Barberini) in 1644, as the ecclesiastical authorities still feared the consequences of the Papal index. The problems remained for many decades, since Mayr did not offer Galilean works in Ljubljana in 1678. So, only Galileo's proportional compass in its first edition (1606) is still preserved in Ljubljanian libraries, while *Il Saggiatore* written against the Jesuits of Grassi in the first edition (1606) was acquired in Maribor, also in the first Roman edition of 1623. In any event, Auersperg had the opportunity to read Galileo's opus as the whole, since he surely did not forget to secretly look at his controversial Dialogues.

The father of Janez Vajkard Auersperg, Dietrich, studied in Tübingen only shortly after Kepler. Nevertheless, Auersperg did not buy much of Kepler's works. The family of Auersperg did not acquire neither the *Mysteries* dedicated to Kepler's

friend Styrian governor (Landeshauptmann) Sigmund Friderik Herberstein, nor Rudolphine tables, not to mention the more Copernican-oriented Kepler's writings. Perhaps you would expect at least Kepler's Rudolphine tables, which were sold by Bookshop of Mayr in Ljubljana in 1678; however, the Auersperg did not store the Rudolphine tables in their library, unless they were cataloged in more than one hundred calendars listed at the end of the mathematical books list. Nowadays older Kepler works are not kept in public Slovenian libraries. Auersperg acquired the first edition of Kepler's optics from 1604 with the first mathematical treatment of the law of reflection and the vacuum interconnection space; he did not have other Kepler's works. In 1604, Kepler dedicated his optics to Rudolf II and laid the foundation for modern exploration of light. This Addition to Witello, the medieval Polish optician, Kepler wrote already in Graz, but then he indeed finished it in a hurry during his study of Tycho's measurements of Mars in Prague. He explained reflections of light as well as the operation of the eye and his own short-sightedness. At his Addition to Witello, Kepler frequently cited Porta to recognize the invention and even the first production of a relatively cramped Porta's telescope. According to Euclid's example, Kepler compiled his work full of assumptions, definitions, demonstrations, lemmas, and corollaries, since he already advocated Euclid's works in Maestlin's class in Tübingen in 1596, and he beloved such an approach. Kepler made a special table of his measurements of the solar eclipse in Graz on 30 June 1600/10. 7. 1600. The use of then popular wooden measuring device led Kepler to a more detailed study of optics.

Apart from Bacon's works, Auersperg did not buy books related to Londoner Royal Society, such as Robert Boyle, Hooke or Wren's notes on vacuum experiments. Similarly, we miss the works associated with the then new Parisian Royal Academy. Of course, both institutions were created in the era when Janez Vajkard Auersperg had just seen Abraham in his 50th year of age. Auersperg even obtained a polemical theology of Valeriano Magni. Magni and Pascal initially quarrelled over alleged priority rights of their invention of new vacuum experiments, but later they preferred to criticize the Jesuits jointly. In 1647 Magni showed vacuum experiments at the Polish court and published them in the book full of sharp critic of

Aristotle. Roberval charged Magni for plagiarism as Mersenne testified that he had personally informed Magni of Torricelli's experiments at their meeting in Rome.³¹⁶ In any event, Magni had to hear something about Torricelli's achievements during his Italian tour, which was the theme of the day after Torricelli's letter to Michelangelo Ricci dated 13 June 1644.

Magni wanted to be the inventor of Torricelli's vacuum barometric experiments at the National Assembly in Regensburg in 1654; there he met the Prince Auersperg, who was one of most relevant political stars of his era. He did not miss the mayor of Magdeburg, Otto Guericke, whose father, during his young years, carried out his duties for the Polish king. Guericke did not quite believe Magni's narrations, as he had already heard something about Torricelli's successes in the meantime. Magni as the first accurately described the passage of light through the air and through a vacuum,³¹⁷ and his criticism of Aristotle's rejection of the existence of a vacuum was the greatest challenge to the Jesuits of that time. At that time, Magni was at the height of his life, and as a Capuchin, he was not a pleasant interlocutor to the Jesuits.

Jean Rodolph Lefèbvre (Faber, * about 1580; † 1650) from Geneva became a professor of law and philosophy at Bern. In 1625 he published the *Philosophy*, which was purchased by Auersperg. The book was reprinted in the following year. He divided the physics in general and special kind. Those were still the sharply divided areas. The first, he described the rise in air pressure above the body, which is expected to accelerate its fall and further reduce the resistance of the air under the body. He described the siphon and the cannon project against the existence of a vacuum.³¹⁸ Even during the freezing of hot sealed water, Lefèbvre (Faber) attempted to solve the claim that the container would rather burst than to permit the existence of an emptiness.

Auersperg bought Melchior Cornaeus's (1598 in Brilon-1665 Mainz) *Curriculum of Philosophy*, which was offered to Carniolan customers by their new bookseller Mayr in Ljubljana.³¹⁹ The Jesuit

Cornaeus retreated to France during the Thirty Years' War and taught philosophy in Toulouse for seven years. After returning to Germany, he taught scholastic and polemical theology in Mainz and Würzburg as a co-worker of ten years younger teacher of mathematics, the Jesuit Schott. He became a rector in Würzburg and then in Mainz. Of course, Cornaeus defended Peripatetic philosophy by remaking a new science together with Schott. With Schott's inherited vacuum pump, they also rebuilt a new kind of complementary science with the cautious remaking of Aristotle's ideas which later proved to be abortive anyway. Schott praised Cornaeus's careful study of experiments and in his *Mechanica Hydraulica* even reprinted some of the descriptions of experiments in the empty from Cornaeus's *Curriculum Philosophia* under the title *Melchioris Corneai Diatriba de Novo Experimento*. Among the twenty-seven Cornaeus's published works were his letters, which Kircher communicated to Iter Exaticum.³²⁰ Schott discussed Cornaeus's views on the vacuum, at the very beginning of his first reports on Guericke's experiments involving the Prince of Auersperg, and those parts of a book certainly supported Auersperg's attempt to include eight Schott's works into Auersperg's Library, among them three in the joint bindings.

Auersperg's librarian, son of the mayor of Ljubljana Janez Ludvik Schönleben, included Schott's *Mechanics* among the books on architecture. There Schott reprinted Kircher's letter sent from Rome on 26 February 1656. Kircher discussed Cornaeus' hydraulics of "presumably" emptied receivers. Kircher offered a simple description of the supposed vacuum of another Jesuitical hydraulics expert turned astronomer Valentin Stansel (Estancel, 1621 Olomouc – 18 December 1705 Salvador Bahia in Brazil). In any case, Kircher insisted on Aristotle's ideas of opposing "vacuumists", as he was not able to escape the puzzles of disconnections and the problem of the impact of force (*Impetus*) in an emptiness. Kircher was convinced that even after pumping some air remained, while Schott nevertheless accepted Riccioli's compromised Galilean description of the weight of the air. Schott put some pages of beautiful pictures into his description of Heron's well and fountains.³²¹

³¹⁶ Sousedik, 1983, 75.

³¹⁷ Guericke, 1986, 92-93, 108.

³¹⁸ Lefèbvre, 1626, 122; Thorndike, 1941, 6: 397-398.

³¹⁹ Mayr, 1678, 72.

³²⁰ Schott, 1657, 465-486; Kircher, 1657, 509-512.

³²¹ Schott, 1657, 451, 453, 169, 193, 384.

Janez Vajkard Auersperg obtained several Daniello Bartoli's books printed in Bologna where Janez Vajkard Auersperg studied from spring to autumn in 1633. Bartoli was seven years older than Janez Vajkard. His school benches were in Piacenza and Parma and he learned his theology in Milan and Bologna. Bartoli studied in Bologna in the class of physicist Riccioli who later also taught Janez Vajkard. Bartoli and Grimaldi served as Riccioli and Niccolò Zucchi's (1586-1670) assistants in their pioneering observation of the belts of Jupiter simultaneously discovered by Evangelista Torricelli in 1630.

After his travels, Bartoli returned to Rome in 1650, where in his letters he repeatedly reported to his friend about the limitations in describing the physical truths posed by their Jesuitical order. Indeed, Bartoli became the leading baroque literati of Italian vernacular with his *L'huomo di lettere difeso ed emendato* published in Rome in 1645; Bartoli and Kircher were the Roman stars of the Jesuits also with their subsequent descriptions of China. Bartoli was a professor and rector of the Roman college. He repeated Pascal's measurement of altitudes with the barometer.³²² Despite the Jesuits like Linus,³²³ Bartoli defended the pressure of the air contrary to the outdated conception of tension or even strangest fear of empty. He compared the evidence of the stresses in emptiness in the older theories of Torricelli's pressure above the vacuum; he accepted a modern belief.³²⁴ Nevertheless, he rejected Magni's³²⁵ and other philosophical explanations of the vacuum. Volf Auersperg did not buy this most physically colored Bartoli's book entitled the Tension and pressure (*La tensione, e la pressione*), which came out just before the death of his brother the prince Janez (John) Vajkard. In view of his cooperation with Guericke, Janez was particularly interested in the »substance« of vacuum; to the prince's lesser-minded heirs, however, the purchase of science of that kind may have seemed a little too deep. Janez probably himself ordered that Bartoli's book in its first Bolognese edition but he died on 13th November 1677 in the year when it was published, therefore he might not be able to read it carefully enough. The Friars minor observants of Ljubljana obtained the Venetian edition published next year

which proved their early interests in vacuum experiments.



Figure 5-5: The first Auersperg Prince Janez Vajkard, after the appointment in 1654, was also commissioned to mint his own money as shown by the painting. On one side of his coin, he put his coat of arms, and on the other, of course, he engraved his own image. The silver coins proved to the last doubters that the vacuum plays really pays off)

Bartoli did not believe in the compressibility of water, which was convincingly demonstrated by Herbert and his pupil, the professor Anton Ambschell of Ljubljana, almost a century later. Bartoli mistakenly assumed that Torricelli had undergone his experiments in Florence before Berti's performance in Rome;³²⁶ the historians did not correct the error until the middle of the 20th century. Bartoli's work on Geography was offered by Mayr in Ljubljana in 1678. Zois bought Bartoli's book about ice and its coagulation in its only Bolognese Italian edition entitled: *Ghiaccio e della Coagulatione*.

Kircher's student Lana Terzi was a member of the Royal Society of London; he corresponded, of course, to its secretary Oldenburg. In the year

³²² Bartoli, 1677, 66.

³²³ Bartoli, 1677, 96.

³²⁴ Bartoli, 1677, 185, 233, 241; 253; Gorman, 1994, 9.

³²⁵ Bartoli, 1677, 274.

³²⁶ Bartoli, 1677, 75, 91.

5.2.3 *Guericke's Vacuum Experiments at Auersperg's Ljubljana Library*

Janez Vajkard Auersperg (Weikard, * 1615; † 1677) led the politics of Emperor Ferdinand III who was raised by the Jesuits and became even capable linguist and composer of the church music. After the death of Ferdinand II, Janez Weikard became a court councilor on 17 January 1640. A few weeks later he was sent to The Hague, where he became acquainted with Emperor Counselor the Count Otto Piccolomini and the secretary of the State Court Office Johannes Baron Walderode. Piccolomini was a member of the Fruchtbringende Gesellschaft, therefore Janez dedicated his memories to Piccolomini in Vienna upon his death. That memorial book was kept at the Auersperg Library in Ljubljana, while nowadays it is in a library in Wolfenbüttel along with eight Auersperg's almanacs and other works. As a member of the Fruchtbringende Gesellschaft, Piccolomini mediated with Janez that Janez should support Stubenberg's translation of the famous Francis Bacon, the first in the German language. Janez gave the Fruchtbringende Gesellschaft a magnificent and, of course, an expensive golden cup in 1657.³²⁷ Bacon was, of course, the beginner of experimental thinking. His glory brought to him the respect of the Royal Society of London; unfortunately, his publications do not contain illustrations that were so characteristic of a later stance in physical experiments following the efforts of the Galilean Academy of Lincei. In the year 1654 the lower Austrian nobleman Stubenberg devoted a translation of Bacon's work to Auersperg a few months after the emperor's assignment of the title of prince to Auersperg. Stubenberg dedicated his translation of the other Bacon's work to King Friderick IV at the same time. Janez Vajkard Auersperg, during his collaboration with Guericke in vacuum experiments, became a knight of golden fleece, a conference and state minister. Are vacuum experiments, therefore, worthwhile?)

Janez Vajkard Auersperg acquired the first printed descriptions of Guericke's experiments published by the German Jesuit, Kircher's scholar Schott. Schott wrote most of his physics in his *Interesting Technique* dedicated to the Würzburg and Worms Archbishop the prince-electoral of Mainz Johann Philipp von Schönborn, the same who bought a vacuum pump from Guericke a decade earlier. He donated that pump to the Jesuit University in Würzburg shortly before Schott began lecturing there.



Figure 5-6: The cover of the book of Schott's teacher Kircher issued in 1657, where Auersperg's librarian Schönleben specifically emphasized that it was a gift from Kircher himself. Auersperg had nineteen Kircher's books in Ljubljana; at least three of them were donated to him personally by Kircher, probably with the little help of Ljubljana Jesuits.

Auersperg naturally acquired Schott's book of the Pneumatic Mechanics with the first printed description of Guericke's vacuum experiments. Three years before Schott's edition, the newly promoted Prince Auersperg co-operated with Guericke's experiment in Regensburg in 1654.

1670, he was famed for his description of aircraft carried by the emptied hollow copper metal balls; the idea obviously impressed Auersperg when he purchased Lana's book. It is less likely that Janez Vajkard Auersperg would also test vacuum balloons on the roof of his Ljubljana palace, as they were never successfully flown anyway.

³²⁷ Bircher, 1995, 289, 297.

Guericke corresponded with Schott but probably never met him in person. Auersperg also visited Schott in the imperial Embassy.

The Ljubljana Jesuits bought for their library in Ljubljana the more recent Schott's posthumously issued book entitled »the interesting techniques« for the founding of their studies of philosophy. Auersperg had it before. In this important book, Schott accurately cited early vacuum experiments in Europe and England, which particularly interested the first Auersperg prince. Schott relied on his Hydraulic-pneumatic mechanics and again rejected the existence of a vacuum.³²⁸

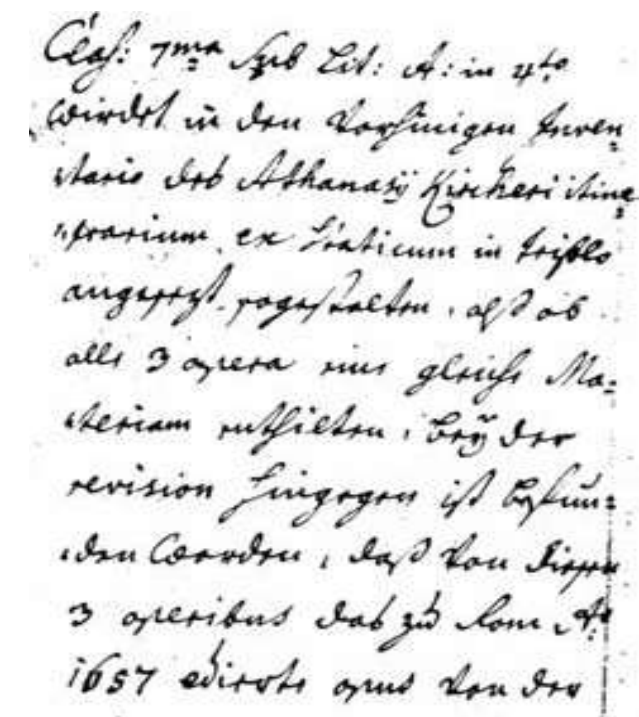

Figure 5-7: A catalogue of Auersperg's books, which on page 227 lists Kircher's (1657) work with its numerous vacuum discussions (1668, after the transcript from 1762, Vienna, Haus-, Hof- und Staats-archiv, Auersperg-Archiv VII, A / 14/4 (Minoritenplatz 1, Haus-, Hof- und Staats-archiv, Fürstlich Auerspergsches Archiv , VII Laibach, A 14/4 conv. 1 Laibach-Fürstenhof 1729-1895, Page 227).

Georg Philipp Harsdörffer was a member of the German Fruchtbringende Gesellschaft since 1642. His academical name used to be the Der Spielende which he used as a signature under his introductory glorifying poem on 2 + 2 pages to praise the patron Janez Vajkard Auersperg and even more Bacon

³²⁸ Schott, 1687, 185-223, 255, 258.

Verulam in the translation of his fellow member of *Hochlöblichen Fruchtbringenden Gesellschaft* Johann Wilhelm count Stubenberg with academic name *Unglückseligen* in Nurnberg in 1654. Georg Philipp Harsdörffer studied law in Altdorf and listened to Schwenter's lectures. In 1652 he became a constituent, and from 1655 until his death, he was a member of the Nuremberg home counsel. He also worked on literature and music, especially in the *Der Grosse Schauplatz jämmerischen Mordgeschichten*, a collection of horror stories that Auersperg certainly enjoyed reading during the foggy Ljubljana winter evenings.

The first part of *Deliciae*, a book on fun mathematics and physics, was primarily Schwenter's work, although Auersperg's librarian attributed it to Harsdörffer. In 1636, Schwenter in his *Deliciae* described improvement of the microscope by twisting, modelled by the model of the human eye. In the same part, he described the fountain pen,³²⁹ the numerous vacuum experiments and the flight of a bird filled with air.³³⁰

Daniel Schwenter (* 31. 1. 1585 Nürnberg; † 19. 1. 1636) was the merchant's son and studied under supervision of the professor Daniel Gelegengeim in his native Altdorf. Among Schwenter's professors was Johannes P. Praetorius (* 1537; † 1616), whose books were also purchased by Auersperg. Schwener became a professor of Old Eastern Languages and Mathematics at Altdorf University near Nuremberg. In 1626 he described measurements with proportional heights according to Galileo's model: Auersperg did not get it because he already had a dozen books on that thematic.

Harsdörffer added volumes 2 and 3 to Schwenter's *Deliciae* in 1651 and 1653. The library of Auersperg did not acquire them, but other residents of Ljubljana had both the first and the second edition. Harsdörffer was interested in Magni and Kircher's experiments with vacuum above a column of mercury, but he did not mention Guericke.³³¹ He described a popular Torricellian experiment of those times with a tube full of mercury, which is closed with a finger and then turned. He was interested in Magni's and

³²⁹ Schwenter, Harsdörffer, 1636, 1: 519-520.

³³⁰ Schwenter, Harsdörffer, 1636, 1: 454, 472.

³³¹ Thorndike, 1958, 7: 594; Harsdörffer, 1651, 2: 464-467.

Mersenne's experiments with Torricelli's vacuum, in Pascal's barometric altitude measurements, and in Bramer's vacuum experiments.³³²

After the death of his father, the sister took care of **Benjamin Bramer** (* 1588 Felsberg; † 1652 Ziegenhain). She was married to Bürgi. In the year 1604 Joost Bürgi (Jobst, Jöst, * 28 February 1552 Lichtensteig in Switzerland; † 1632 Kassel) took Bramer with him to Prague, where the young man remained for five years. From 1603 to 1612 in Prague Bürgi was Kepler's assistant hired for computing, dealing with logarithms and ballistics. Bramer published a book on a vacuum in Marburg. He designed an experiment like the later Guericke's; he considered the vacuum to be primarily the air that is squeezed out of bodies with water or fire.

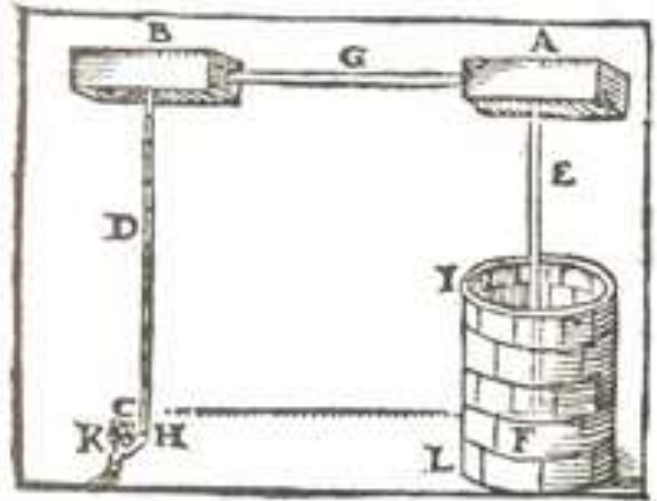

Figure 5-9 Schwenter's barometer with a pump (Schwenter, Harsdörffer, 1636, 487).



Figure 5-8: Schwenter fountain pen in the Auersperg Library (Schwenter, Harsdörffer, 1636, 1: 560).

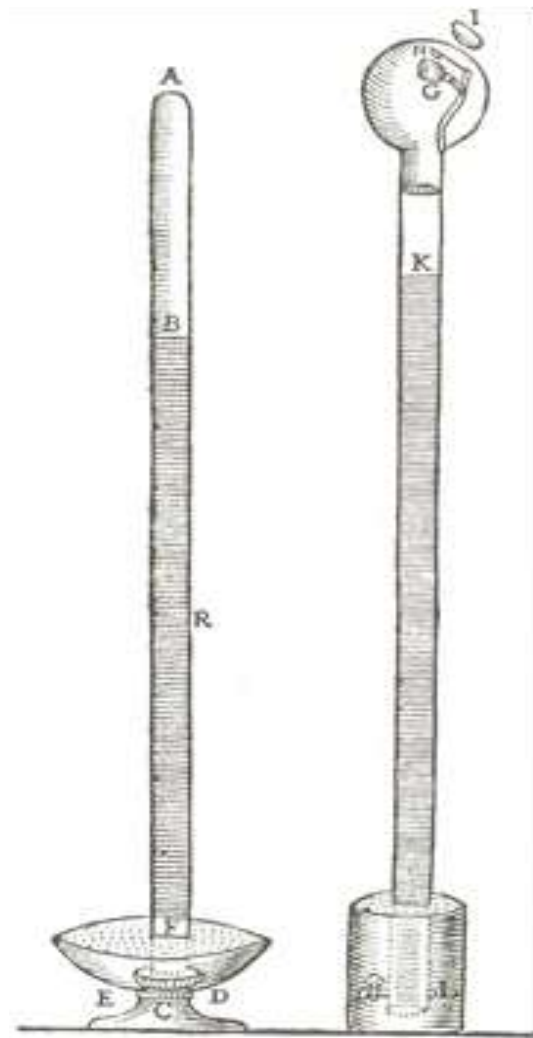

Figure 5-10: Schwenter's thermometer and barometer (Harsdörffer, 1651 2: 465).

³³² Harsdörffer, 1653, 3: 659, 466.

5.2.4 Conclusion

Within expectation, the first Ljubljana-Carniolan vacuum researcher procured numerous books on vacuum experiments. His interest in scientific experiments was crowned with his material support for the first German translation of Bacon's work, which allowed the penetration of new ideas also in Ljubljana.

5.3 First Prince Auersperg and the Capuchin Valeriano Magni

5.3.1 Introduction

Recently, the contribution of the Jesuits to the development of science, especially the early research of the vacuum, is most emphasized. The advantage of the Jesuits lies in the fact that today there are a quarter of them in the US while the American side of Atlantic is the most important source of research for the history of vacuum techniques. On the other hand, the contribution of the Franciscans, especially the Capuchins, was not much smaller, although the Jesuits were often in quarrels with Franciscans, especially regarding to the existence of a vacuum.

5.3.2 Rheita, Auersperg and Schönborn

Guericke produced the first pump in Magdeburg in 1648; that year officially ended the 30 years of war and started the 300 years of victorious path of vacuum techniques. Two years after the discovery, Guericke ordered to his servants to build a pump, which emptied the hemispheres for the famous experiment in Regensburg in 1654. The doubting Prince from Carniola, Janez Vajkard Auersperg assisted him. After a successful experiment, many bon vivant were interested in the purchase of a pump. Guericke sold the device to Prince Schönborn,³³³ who offered him the most; he was the prince of Würzburg and Worms, and the archbishop-elect of Mainz, and he was not running out of the money at all. He did not buy the pump for himself but gave it to his Jesuit university in Würzburg. As early as June 22, 1655, from his journey to Mainz, Schott wrote to Kircher

³³³ Hellyer, 1998, 265; Guericke, 1986, 113.

about the Guericke's Pump, before taking it along with the lectures of mathematics at the University of Würzburg in 1655/56.

Schönborn closely collaborated with Anton Maria Schyrl (Rheita, * 1597/1604 Reutte in Tyrol; OFMCap; † 14 November 1660).³³⁴ Rheita invented the eyepiece for a Keplerian telescope and the binocular Telescope (1645),³³⁵ which is still used today, unlike Kepler's variant. Rheita coined the term ocular and objective for the eyepiece and the lens, and even bothered to paint a map of the Moon (1645). The second edition of his *Oculus Enoch* was equipped with an addition.³³⁶ On October 14, 1623 he matriculated to the humanistic studies of Ingolstadt University;³³⁷ there he heard more about Tycho's merits, than about Copernican science.³³⁸ That is why he defended Tycho Brahe's system of planets; of course, Tycho as an angry man with a mighty mustache under an artificial nose from an elephant's bone already passed away. Rheita ensured the existence of several satellites around Jupiter, Saturn and Mars (1643),³³⁹ of course, other literati did not believe him much,³⁴⁰ because at that time many other similar unproven ideas circulated among the scientists' networks. In later manuscripts Rheita described a geometric tube for the optical distance measurement, a periscope as the precursor of the panoramic telescope; he also did not forget to describe the structure of atmosphere on Jupiter with some funny guesses about the initial sins of the alleged inhabitants of Jupiter.³⁴¹

Before his invention of the telescope, Rheita had long correspondence with Johann Philipp von Schönborn (* 1605; † 1673).³⁴² On 21 March 1651, he wrote to his brother Alberto, who was in the military service, about his binocular telescope, which he provided for Schönborn's collection.³⁴³ Later, he clashed with Schönborn, so Schönborn's office in Mainz arranged Rheita's arrest in Brussels

³³⁴ Thewes, 1983, 10, 45.

³³⁵ Thewes, 1983, 13.

³³⁶ Thewes, 1983, 46.

³³⁷ Thewes, 1983, 11.

³³⁸ Thewes, 1983, 14.

³³⁹ Lenhart, 1923, 24.

³⁴⁰ Thewes, 1983, 10, 45.

³⁴¹ Thewes, 1983, 47.

³⁴² Thewes, 1983, 19.

³⁴³ Thewes, 1983, 22-24.

on 21 January 1653.³⁴⁴ After the inquisition process, Rheita was expelled to Ravenna;³⁴⁵ his problems resembled the destiny of the other Capuchin V. Magni. The wealthy Schönborn was not particularly disturbed, so he arranged a private astronomical observatory in Würzburg and hired Ignacio Christian Bezold to this purpose.³⁴⁶ This made Rheita's idea possible, as Rheita planned to set up his first European observatory equipped with the telescopes in Mainz,³⁴⁷ which was earlier carried out only by Landgrave Wilhelm IV of Hesse-Kassel (1532-1592) and by Tycho Brahe.

5.3.3 Vacuum Experiments of Capuchin Valeriano Magni

Valeriano count Magni can be placed alongside Schyrl Rheita and Cherubin Le Gentil (Chérubin, * Orleans, OFM Cap, † 1697) as the third famous Capuchin inventor.³⁴⁸ Among the Capuchins served many other discoverers: the Capuchin Francis Marie Jablier has invented a photometer; the corresponding member of the Parisian Academy, Capuchin Emmanuel of Viviers, has compiled many popular microscopes and telescopes. Capuchin Chrysologus André designed the planispheres, maps and improvements to the barometer.³⁴⁹ Galileo's correspondent Hilarius Altobello (Ilario Altobelli, 1560 (Montecchio (Treia) in Macerata-1637) published a map of stars which even Kepler used.³⁵⁰ The Franciscans and Capuchins also made a great deal of missionary work, although Kircher, as a hostile competitor, did not attribute such importance to them as he did to Jesuit group of the Carniolan Bernhard Diestel, J. Gruber, and Albert D'Orville, who left Beijing in 1661 and headed for Lhasa in Tibet.³⁵¹

The experiments had their early deep influences on the Franciscan view of the world, and it was brought to the highest point by Capuchin Valeriano Magni (Maximilian Magnani, Magnus, * 11. 10. 1586 Milan, OFM Cap 25. 3. 1602 Prague;³⁵² † 29. 7. 1661 Salzburg), the most important Capuchin

Baroque researcher of vacuum. Volf Engelbert Auersperg has even acquired Magni's polemical theology from Magni's mature years. Magni was born as the third child of the Italian merchant Constantine Magni (Costantino, 1527-1606) from Como. Costantino arrived in Milan in 1563, and worked in Vienna at an imperial secret council. He served Habsburg emperors, Maximilian II and Rudolf II. In 1588 he moved to the Prague Emperor's Palace and named his son by the ruler Maximilian. His name was kept until the gifted boy turned into Capuchin Valeriano.



Figure 5-11: Valeriano Magni around 1628, a few years before his vacuum experiments

Valeriano was a young Capuchin in Vienna from 28 August 1603 to 11 March 1605.³⁵³ By 1605, he studied philosophy with physics included in Prague.³⁵⁴ Valeriano briefly taught in Vienna (1613). He was sent to Linz³⁵⁵ during the Viennese (1613) and the Prague plague. In 1614, he taught philosophy in Vienna, and in 1616 he went to Poland.³⁵⁶ In 1619, he transferred to Linz as the Guardian and Master of the novices;³⁵⁷ he met Kepler there.

Magni also supported Galileo's ideas in opposition to some Jesuits, which were quite bitter to such novelties, because the vacuum had gone into their noses. After short teaching in the Prague University, Magni became a Habsburg deputy in Paris (1622-1623); there he personally became

³⁴⁴ Thewes, 1983, 33-34.

³⁴⁵ Thewes, 1983, 46.

³⁴⁶ Thewes, 1983, 44.

³⁴⁷ Thewes, 1983, 47.

³⁴⁸ Lenhart, 1923, 25.

³⁴⁹ Lenhart, 1923, 25.

³⁵⁰ Lenhart, 1923, 26.

³⁵¹ Lenhart, 1923, 37.

³⁵² Cygan, 1989, 33, 230; Abgottspon, 1939, 25.

³⁵³ Cygan, 1989, 33.

³⁵⁴ Cygan, 1989, 38.

³⁵⁵ Cygan, 1989, 40.

³⁵⁶ Cygan, 1989, 43.

³⁵⁷ Cygan, 1989, 46.

acquainted with leading vacuum researchers, including his two-years younger B. Pascal's father and the Minim Mersenne.

In 1623 he returned to Vienna as a defensor. Magni became a guardian in Prague,³⁵⁸ where he soon became involved in a dispute with the confessor of Emperor Ferdinand II, the Jesuit Gulielmo Lamormain (Lamormaini), especially for Valeriano's opposition to the Jesuit takeover of the



Figure 5-12: The cover of Valeriano's book, where he first described the vacuum above the mercury column to explicitly advocate the vacuum.



Figure 5-13: The Parisian edition of Valeriano's problems, which was followed immediately by Warsaw edition in 1647

Prague University³⁵⁹ where Valeriano got his support from the famous optician Marcus Marci. Valeriano also polemized with the father of modern education Jan Amos Komenski (Comenius, Komenský, 1592-1670), who under the pseudonym published the criticism of Valeriano's theology in 1644,³⁶⁰ and with the Cistercian Caramuel von Lobkowitz.³⁶¹ For a while, Magni even served as a Provincial of the Bohemian Capuchin Province (1624) until he became Apostolic Missionary in Poland, Hungary and the Holy Roman Empire of German nation in 1626; despite of the awkward name, the empire was also inhabited with Slovenians. In 1625, Valeriano was elected Bohemian provincial in Rome,³⁶² and in November 1627 he was in an audience with the emperor.³⁶³ In Prague, during 1626-1628 he worked closely with the most important warlord of his time, Dietrich Auersperg's classmate Wallenstein,³⁶⁴ who was very interested in the problems of vacuum and other sciences. For that purpose, he hired a personal astrologer, Zenno.

Magni cooperated with the Cardinal Archbishop Ernest Adalbert de Harrach (Arnošt Vojtěch hrabě z Harrachu, * 1598; † 1667). He travelled with him from Prague to Vienna to visit the Emperor.³⁶⁵ Magni established himself as an adviser to the Prague Archbishop Harrach (1622-1634), a later Cardinal. Valeriano tried to persuade the Galilean camp the Archbishop Cardinal Franciscus de Dietrichstein († 1636) who served as the Bishop of Olomouc from 1599.³⁶⁶ Magni used his social relations among the Czechs to arrange the printing of Galileo's Discorsi full of hints for vacuum experiments. Unfortunately, the cardinal passed away before the deal was accomplished up and the book was published by the Dutch. Magni tried to persuade the Cardinal Dietrichstein to publish Galileo's Discourse in the Bohemian Lands through his social contacts; unfortunately, the cardinal just released his sinless soul at that time and the book was only later published in

³⁵⁹ Abgottspon, 1939, 31, 34, 54; Cygan, 1989, 237.

³⁶⁰ Abgottspon, 1939, 65; Cygan, 1989, 80, 92, 225.

³⁶¹ Abgottspon, 1939, 62.

³⁶² Abgottspon, 1939, 27.

³⁶³ Abgottspon, 1939, 55.

³⁶⁴ Cygan, 1989, 424; Mann, 1971, 94-96, 442, 444-448, 523-546, 1229, 1235.

³⁶⁵ Nicolaus from Lucca; Ludwig from Salice, 1976, 35;

Cygan, 1989, 50.

³⁶⁶ Cygan, 1989, 52.

³⁵⁸ Cygan, 1989, 49.

Leyden.³⁶⁷ The clever Valeriano became familiar with vacuum problems at the same time. Thus, the young Valeriano was acquainted with the main innovations of the then science at an early age; Throughout his prolonged work, he acknowledged his Galilean description of the vacuum.

Magni's eruditions as the magnificent aspirations gave a powerful momentum to vacuum research within the Capuchin order, which Magni helped to establish in the Polish kingdom. In 1634, his early description of Protestantism was translated by the English. He was fierce and sometimes quite a passionate writer.³⁶⁸ The Capuchins wanted Valeriano to be elected as their general, and the Polish king Vladislav (Ladislaus) wished to provide for Magni a nice red cardinal hat,³⁶⁹ unfortunately, in 1643, Magni was not successful enough to collect enough support directly because of polemics about Magni's first edition of *De luce mentium et eius imagine* on 8. 9. 1642. Magni again met the influential persons at his visit to Rome three years later. Likewise, a quarter of a century later, a cardinal hat escaped the stubborn head of Wolf's brother, the Auersperg Prince Janez Vajkard. Volf Engelbert Auersperg acquainted Magni's polemics for his Ljubljana library; Magni's description of Protestants was published even in England in 1634. He became a famous polemical writer.³⁷⁰

On 8 April 1642, Valeriano traveled from Vienna to Graz and Ljubljana, then to Venice and Bologna, along with Fortunato de Tridento, Val di Sole († 1674). Fortunato was thirty years old Valeriano's companion, later a lay perfect of the Bohemian-Austrian province.³⁷¹ On 22 July 1643, Valeriano visited Gorizia and Trieste³⁷² in preparation for the Styrian provincial assembly, which included most of Inner Austrian places; the meeting was in May 1644, when Magni returned to Gorizia and Rome to meet the then Styrian provincial, the Guardian Silvester.³⁷³ Thus, Valeriano was well acquainted with Kristof from Cividale (Čedad, * 1606; OFMCap 1623, † 5. 9. 1674). On 28 January 1664 (by the Gregorian calendar on 11. 2. 1664) Kristof carried out the

first documented astronomical observation of the eclipse on the road between Vrhnika and Logatec.

When visiting the Slovenian places Valeriano, of course, lived with Capuchins and told them about his *De luce* and about planned vacuum experiments. As an experienced professor skilled in vacuum experiments, he also helped in teaching, since the Gorizia Capuchins led their internal philosophical studies with some intervals after 1591. The Bishop Tomaž Hren laid the foundation stone of the Ljubljana Capuchin church of St. John the Evangelist on April 25, 1607; in the quiet, he must have felt that it would become the largest in the then Styrian province. The Ljubljana Capuchins were mainly set up with a well-equipped well-known pharmacy, a bookbinding and the production of the monastery clothes.³⁷⁴ In 1622 they established a library. Unfortunately, the French dissolved their monastery in 1809. It is said that Marmont's wife was angry after she supposedly caught a Capuchin's handkerchief on her nicely decorated breast during Capuchin's violent speech. In 1817 the monastery was demolished along with the church;³⁷⁵ but the reports of the further fate of a fatal dirty handkerchief, unfortunately, are still silent.

In 1645, the Polish king Ladislaus (Vladislav) sent Valeriano Magni to Rome to prepare for the Torino Congress; the inspired Capuchin benefited the Romans by sharing with them his book *De luce*.

In the following year 1646, the Capuchin Magni independently carried out a Torricellian experiment on Ladislav IV's and Louise-Marie Princess de Gonzague-Nevers's Warsaw court. Queen's Secretary, Pierre Des Noyers, immediately informed French physicists of success. The Capuchin Magni set the barometer experiment next year for his Warsaw ruler Ladislaus IV and even more so for his bride, Louise-Marie de Gonzague, Princess Nevers (1611-1667). The queen's secretary, Pierre Des Noyers (* 1608; † 1693), immediately informed Roberval (4. 12. 1647)³⁷⁶ and other French physicists from the Pascal's Circle of Magni's success. Valeriano himself wrote to astronomer and mayor Jan Hevelius in Gdansk (25 January 1648) and to the Parisian Mersenne

³⁶⁷ Sousedík, 1983, 21, 31, 55; Abgottspon, *ibidem*, 10.

³⁶⁸ Teraš, 1929, 57.

³⁶⁹ Nicolaus from Lucca; Ludwig from Salice, 1976, 15.

³⁷⁰ Teraš, 1929, 57.

³⁷¹ Cygan, 1989, 92, 256.

³⁷² Cygan, 1989, 89, 182, 259.

³⁷³ Nicolaus from Lucca; Ludwig from Salice, 1976, 91.

³⁷⁴ Benedik, Kralj, 1994, 23.

³⁷⁵ Bahor, 2005, 679-680.

³⁷⁶ Cygan, 1989, 93, 265-266.

about his vacuum experiments (14 April 1648).³⁷⁷ In Gdansk, Valeriano dealt with philosophical and mathematical experiments until November 1648, when he would return to Inner Austrian places of Habsburg monarchy.³⁷⁸ Valeriano's physics was published in 1660 by his nephew, Filip's son Francisco Stephano de Magni Count Strážnice (Strassnitz in Moravia, † 1671). Valeriano's other brother František z Magni (František Magnis ze Strážnice, 1598-1652) was among the victorious Catholic commanders of the Battle of the White Mountain and established Piarists in Strážnice instead of Jesuits with a little help of Valeriano. The other unpublished manuscripts contained Valeriano's papers on vacuum, magnet, "physics of nonexistent bodies", the Solar system, arithmetic, geometry with the Sacrobosco sphere, telescopes, Galileo, Zaberella, Mersenne, Helmont and the vacuum researcher Pascal.³⁷⁹ In his philosophical manuscripts with special chapters on vacuum, magnet and light with heat, Magni imagined round indivisible atoms like particles of bodies and a vacuum between them. Their movements should produce the energy.³⁸⁰ The interest in science continued in Warsaw under the jurisdiction of Ladislaus' stepbrother the new king Jan Kazimierz. Kazimierz was a Jesuit and Cardinal before he married his stepbrother's widow Louise-Marie de Gonzague. Nevertheless, Capuchin Magni, who did not like the Jesuits, supported the throne. Capuchin Magni heavily quarreled with the Jesuits. A few months after the dismissal of his first minister, Guericke's coworker the vacuumist Prince Janez Vajkard Auersperg, Emperor Leopold double-crossed Kazimierz and placed his imperial stepsister as the groom on the prestigious Polish throne. Eleonora was later considered a merciful widow. Mykolas Kaributas Wisniowiecki was the hero of subsequent Sienkiewicz's novels very popular in Carniola. Of course, as the new king, he married his stepsister Eleonora the next year, and poor Kazimierz soon waited for his last days in France.³⁸¹ Among Eleonora's courtiers was Alojzija, the daughter of Prince Janez Vajkard Auersperg.³⁸²

³⁷⁷ Cygan, 1989, 265-266, 293.

³⁷⁸ Nicolaus from Lucca; Ludwig from Salice, 1976, 78-79.

³⁷⁹ Cygan, 1989, 151, 289-294.

³⁸⁰ Cygan, 1961, 614, 617-618, 623, 633.

³⁸¹ K. Targosz, Le mécénat de Louise-Marie de Gonzague, In: *Xii^e Congrès International d' Histoire des sciences* (1971), 137-142.

³⁸² G. Mecenseffy, Im Dienste dreier Habsburger, in: *Archive*

Magni and Pascal initially quarrelled for the championship for new vacuum experiments, but later they rather unanimously criticized the Jesuits. Due to the demand for priority of Valeriano Magni, in October 1647 Blaise Pascal hurried with his publication of the debate »*Novarum Observationum...*« (New experiments with the vacuum). At the same time, he wrote a preface to the book on empty (*Préface pour un Traité du Vide*), which was only partially preserved.

On July 12, 1647³⁸³ Magni described his vacuum experiments in a book full of sharp critic of Aristotle and Aristotelian-friendly Jesuits; this was the first printed description of the properties of the vacuum over a closed mercury tube. In any case, while traveling through Italy, Magni had to hear something about Torricelli's achievements, which became a popular apple of dispute after Torricelli's letter to Michelangelo Ricci on June 11, 1644. The letter was of course secret and private, but soon everyone knew about its description of the vacuum above the mercury. Magni socialized at the highest class of Milano society, only a few hours away from Torricelli's Florence, so he should have heard all about such important news. Roberval has charged Magni with dishonest plagiarism, as he was told by Descartes's former classmate Parisian Minim Marin Mersenne (* 1588; OFMConv 1611; D. 1648) that Mersenne met Magni in eternal Rome and informed him of Torricelli's vacuum experiments in January 1645.³⁸⁴ In any case, Magni had to hear something about Torricelli's vacuum experiment during his Italian journey, which became news of the month after Torricelli's letter to Michelangelo Ricci. After returning from Florence and Rome, the Minim Mersenne published a report on Torricelli's experiment in Paris in the spring of 1645;³⁸⁵ in his monastic cell near Place Royal, he has acquainted the French with new evidence of the existence of a vacuum through a correspondent circle of his friends and visitors. He also talked about motions and vacuum with Hobbes and Descartes, who disliked the vacuums; Descartes liked to emphasize that his emptied glass is still filled with air. On 13 December 1647, René Descartes reported to Mersenne in Paris that he had put the paper

für Österreichische Geschichte (1938), 500, 505.

³⁸³ Cygan, 1989, 95.

³⁸⁴ Sousedík, 1983, 75; Cygan, 1989, 91.

³⁸⁵ Gorman, 1994, 19.

measure parallel to the Torricellian barometer.³⁸⁶ The experienced glassblowers were needed for production of such glass devices; so, Mersenne could not carry Torricellian experiment in Paris, where he did not have competent craftsmen like Pascal had in Rouen. Shortly after Mersenne's death, his associates expanded into the beginning of the Parisian Academy of Sciences.

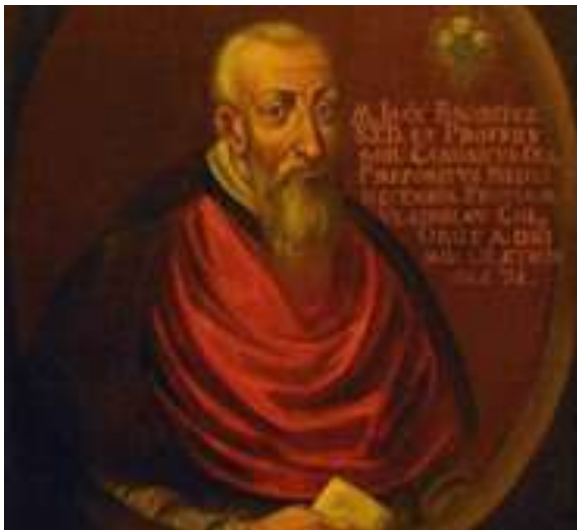

Figure 5-14: Jan Brozek published early critique of Magni from the Jesuit networks in Krakow in 1647.

Magni released his vacuum theory in July 1647, and in September 1647 he wrote and published an addendum.³⁸⁷ Despite of his position in Polish court, Magni's ideas about vacuum were too much controversial to receive much support in Poland. On 18 July 1647 in Krakow, in his *Peripateticus Cracoviensis productur de oculari demonstratione, contra Valeriani Magni demonstrationem ocularem de Vacuo. Vars.*, Jan Brozek (Joannes Broscius, 1585-1652 Bronowice in Krakow) from the University of Krakow, wrote against Magni as advocate of Aristotle. In 1620 during his studies of medicine in Padua Brozek corresponded with Galileo as a prominent biographer of Copernicus. Brozek was the best Polish mathematician of the 17th century and rector in Krakow in 1652, but he was also a sharp critic of Jesuitical influences in his university of Krakow in 1625, which eventually did not bring Brozek any closer to Magni's vacuum. The idea of an enemy of my enemy is my friend certainly did not apply in that case. A year after Brozek, Wojciech Kojalowicz (Albertas Vijūkas-Kojelavičius, * 1605 Kaunas (Kowno); SJ

³⁸⁶ Redhead, 1984, 31.

³⁸⁷ Subotowicz, 1959, 73.

1627 Vilnius (Vilno); † 1677 Warsaw) additionally criticized Magni. Kojalowicz taught philosophical lectures including physics at the University of Vilnius and became a rector there later in 1653-1655.³⁸⁸

In December 1645, Valeriano returned to Poland,³⁸⁹ but he did not give up and wanted to be considered as an inventor of the barometer at the National Assembly in Regensburg 1653-1654.³⁹⁰ Magni did not easily throw his chances away while he wanted to pose as the discoverer of Torricellian vacuum a decade later at the National Assembly in Regensburg (1654); there he met the Prince from Carniola Janez Vajkard Auersperg, the brightest among the then political stars. They did not miss the mayor of Magdeburg, Otto Guericke, whose father used to be a young delegate of the Polish king during his young years. Guericke did not fully believe Magni because in the meantime he himself has heard much about Torricelli's successes.

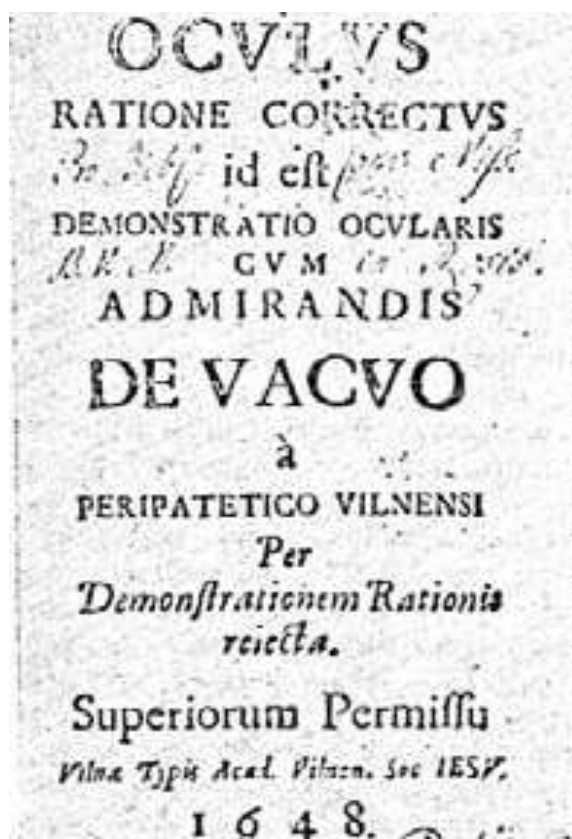

Figure 5-15: The title page of the Lithuanian Vilnius booklet against Magni's vacuum of Wojciech Kojalowicz (1648): *Oculus ratione correctus id est demonstrationis ocularis de Vacuo*".

³⁸⁸ Ogonowski, 1979, 197, 199.

³⁸⁹ Cygan, 1989, 91.

³⁹⁰ Nicolaus from Lucca; Ludwig from Salice, 1976, 144.

Magni gave his book to Guericke, proving the movement of bodies in a vacuum tube above mercury column in the second part of his book; in the last third part of the book, he accurately described the passage of light without a material carrier through the air and through the vacuum. Obviously, Magni did not love particles; he preferred waves, just like the vacuum researchers Huygens or Hooke. According to Guericke's report, he used a long tube of 6/4 Magdeburg cubits (Elle), which was clogged and filled with mercury at one end; they surely took it right from Idrija. When the opposite end of the tube was pressed with a finger, twisted and sank into the reservoir, the mercury slowly descended to a certain height of 5/4 cubits, which is today measured as 760 mm. The Magdeburg mayor Guericke, therefore, measured in cubits somewhat longer than 6 dm.

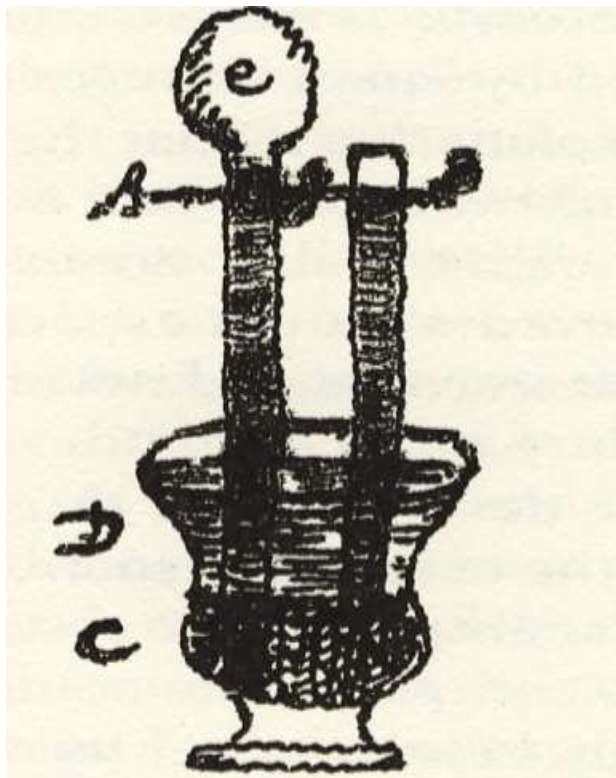

Figure 5-16: Torricelli named an experiment with mercury vacuum in a tube that was almost attributed to the inventive Cappuchin Valeriano Magni.

In any case Magni first described the light passing through the air and the vacuum;³⁹¹ by rejecting Aristotle's critique of the vacuum Magni became a black sheep for all the Jesuits, as he was not a Jesuitical sweetheart because he was a Capuchin.

³⁹¹ Guericke, 1986, 92-93, 108.

Valeriano watched an empty space in the tube over mercury, which was more rarefied than the vacuum which the mayor Guericke³⁹² was able to exhaust with his pump. As the most magnificent critics of Aristotle's rejection of the existence of a vacuum Magni was the greatest challenge to the Jesuit of his days. Magni was just at the height of his life path, but the Capuchin was not a pleasant interlocutor to the Jesuit. In 1659 Magni published a devastating *Contra imposturas jesuitarum* file against the Jesuits. Similarly, Pascal in his Parisian Provincial Letters humiliated the Jesuits; cautious Pascal did not sign up under his masterpiece because he was surely afraid to be caught by the similar impediments which dogged Valeriano.

Magni resented the Jesuit profoundly, especially with his criticism of Aristotle's denial of the vacuum. According to Aristotle, the four basic elements should have the natural direction of movement up or down according to their density. The emptiness has no density; so, Aristotelians were unable to determine the direction of its movement.³⁹³

Otherwise, the Pope Alexander VII (Fabio Chigi, 1599-1667) was very interested in science, but the daily politics forced him to condemn Pascal's letters and even Magni's vacuum. In 1661, following the advice of the Jesuits, he ordered the arrest of Magni in Vienna and his transfer to Rome.³⁹⁴ The Pope Alexander VII was very grateful patron for sciences, but in that case, he had to follow the politicians. In 1661 the curia issued a command for the Magni's transfer from Vienna to Rome for the suspicion of heresy.³⁹⁵ The Pope Alexander VII was quite grateful patron of sciences, but Magni proved to be too naughty even for Papal networks. Valeriano was called to Rome for defense; the magnificent Magni preferred to stay in the hospitable safe city of Vienna, even though by the Viennese proverb the belly had to be left outside. According to the advice of the Jesuits, the Papal Viennese nuncios issued an order for the Magni's arrest in Vienna and his capture in Rome; politics was just above science. Luckily, the Emperor Ferdinand III and his first minister, the prince of Ljubljana, Janez Vajkard, pulled out for

³⁹² Guericke, 1986, 92-93, 108.

³⁹³ Sparnaay, 1992, 12; Podolny, 1986, 21.

³⁹⁴ Gorman, 1994, 19, 21; Thorndike, 1958, 7: 203.

³⁹⁵ Gorman, 1994, 19, 21; Thorndike, 1958, 7: 203; Ogonowski, 1979, 187.

the unlucky Capuchin, who was apparently treading on corns of his mighty opponents. The hunted Valeriano rescued his head by moving to a more remote Salzburg, which was called by Slovenes since the ancient times as Solnograd; there he spent his last months in a monastery in a peculiar house prison, just like Galileo suffered previously in the suburbs of Florence. Shortly before his death, Magni went to Rome while all the ways were still heading to that eternal city; there, with his innate eloquence, he hoped to turn the rulers over to his empty vacuum theories. However, for those times, an old man's journey proved to be fatal; just before he caught his sight of the eternal city, he was visited by inexpressible fatal old woman called death.



Figure 5-17: Will it fall, down? The legendary rhetorical question of Minim Mersenne, who along with his aristocratic colleague fired a bullet from his vertically positioned cannon. Mersenne proposed that experiment in a letter to Descartes when he learned about the density of air, finally proved by vacuum.

Dobrzensky, who at that time had a great deal of clashes with the Carniolan alchemist Rain, believed in the Magni's championship in Torricellian experiments a decade later in his book on the New Philosophy of Fountains,³⁹⁶ which was also purchased by Volf Engelbert Auersperg in Ljubljana; Valvasor collected other books of Dobrzensky at Bogenšperk. Naturally, the Czech Patriotism, which was not entirely foreign to the then educated people, could have been the cause of Dobrzensky's praise, although the networks were more geographically and ethnically colored in those times when Dobrzensky has severely

³⁹⁶ Thorndike, 1958, 8: 202-203; Dobrzensky, 1659, 25, 28; Cygan, 1989, 378.

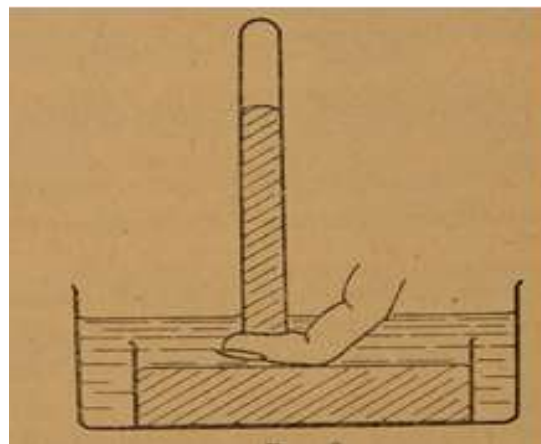

Figure 5-18: Magnified Magni's experiments in July and August 1647 with Hg under water, described on 17 September 1747 (Magni, 1959, 99) and published in the same year (Magni, 1959, 84-85).

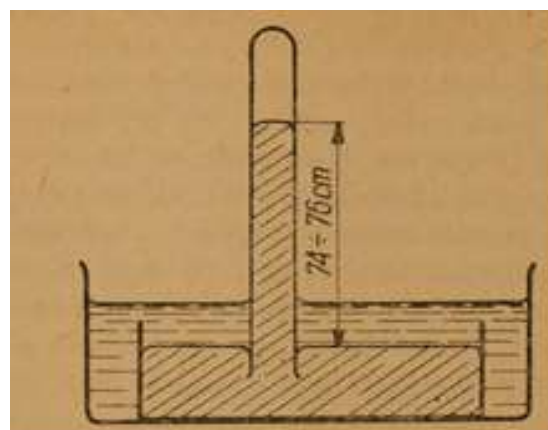

Figure 5-19: Magni's experiments 13-15 from 1650, published in the same year in Venice and in 1552 in Cologne (Magni, 1959, 89).



Figure 5-20: The vacuum researcher Magni on a death bed, painting in oil, which hung up to 1945 in Magni's castle Eckersdorf in the Glatz Midlands County (Bożków 9 kilometres south-east of Nowa Ruda). Later it was moved in the National Museums of Warsaw and Poznań (Nicolaus from Lucca; Ludwig from Salice, 1976, 128/129, 185).

quarreled with the Upper Carniola (Gorenjska) alchemist Janez Friderik Rain regarding the use of the philosophical stone. Even a century later the Carniolan Jesuit and the Ljubljana Rector, Anton Erberg from Dol near Ljubljana criticized the dead Magni, who obviously offended the Jesuits; with his description of the vacuum he pushed his thorn into their eye. Anton Erberg was still angry with the long-dead Magni, who obviously threatened the Jesuits' interests.



Figure 5-21: Magni on a deathbed, later inserted into the older Magni's theological work *Iudicium* (Vienna 1641) (Salzburg, Capuchin monastery) A copy from the Franciscan Assisi Museum (Nicolaus from Lucca; Ludwig from Salice, 1976, cover, 185).



Figure 5-22: Magni on a deathbed (Salzburg, Capuchin monastery). A copy in the Franciscan Assisi Museum (Nicolaus of Lucca, Ludwig of Salice in Italy, 1976, 132/133, 185))

Magni's thoughts about empty were the crown of disputes that had been dragging for over two millennia. The Jesuits who taught Aristotle's physics considered a vacuum as a concept which opposed itself. This was clearly felt in the Latin

language, which happily sounded as empty as "locatum sine loco". Galileo's physics written in Italian language could avoid such verbal contradiction, but Magni (1647) turned that Latin proverb term with its head upside down onto the provocative title of his "locus sine locato".³⁹⁷ Observations and experiments of the influential Capuchin have been based on modern vacuum theory. Because his experiments directly touched the ideas of Otto Guericke, his collaborator, the Prince of Ljubljana Janez Vajkard Auersperg and the other nobles of Carniola who were acquainted with Magni's ideas about the vacuum. That is why Janez Vajkard supplemented his own and his brother's library in Ljubljana with Magni's book; it is not improbable to say that the great writer Magni gave the book to Janez of Carniola, as did Janez's colleagues Kircher or Guericke.

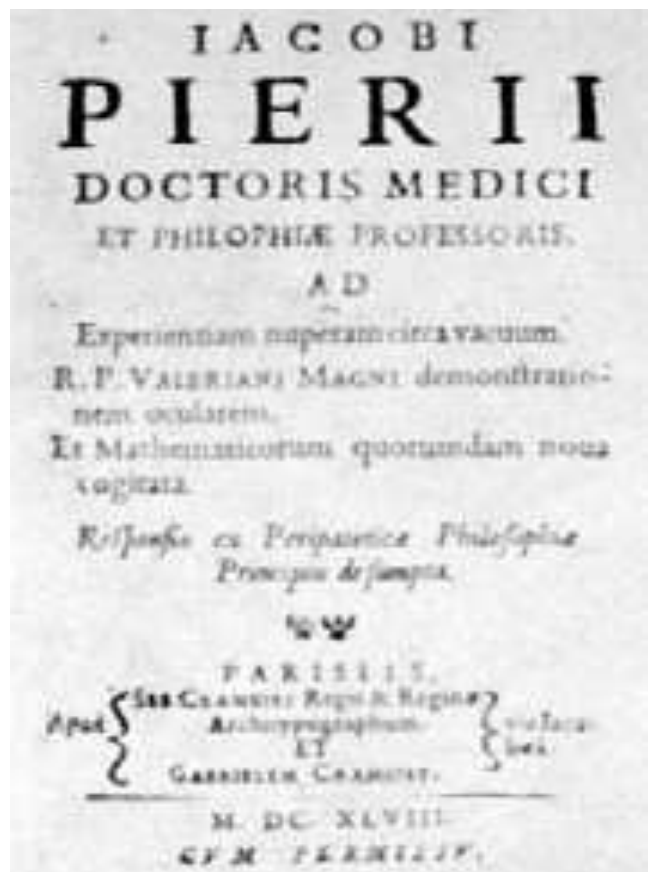

Figure 5-23: The professor of philosophy at Rouen Jakob Pierius' Parisian critique of Magni's experiments from 1648. The title page of the book: *Jacobi Pierii, ... Ad experientiam nuperam circa vacuum, R.P. Valeriani Magni demonstrationem ocularem et mathematicorum quorumdam nova cogitata, responsio ex peripateticae philosophiae principiis desumpta.*

³⁹⁷ Prager, 1980, 48.

However, the times have changed over the next generations while many have accepted Magni's description of the vacuum. What's more: two centuries after the death of its early promotor, the Capuchin Magni, the vacuum has become the basis of all modern technologies, from light bulbs to television displays.

The Frenchmen J. Pierius from Archiepiscopal College of Rouen in 1648 and E. Noël also rejected Magni, as well as the Italian Doctor of philosophy and medicine Johannes Elefantutius (Giovanni Scipione Elefantuzzi, Fantuzzi, † 14. 11. 1648) in his *Euersio. Demonstrationis ocularis loci sine locato, &c.: Pro vacuo imaginario dando in fistula vitrea Mercurio in ea descendente. Ab admod. R.P.F. Valeriano Magno editae*. He published his book in Bologna where he taught philosophy in philosophical college of the Bolognese Grammar School in 1648. The peripatetic Pierius witnessed and criticized Pascal's experimenting in Rouen.

The professor of Collège de France, Roberval, blamed Magni for plagiarism in 1647.³⁹⁸ Noyers sent Magni's Book of 1647 to Mersenne.³⁹⁹ On 5 November 1647, Magni sent to Roberval his defense against charges of his appropriating of Torricellian invention, describing his journey to Rome from 28 April 1642 to May 1643 and in beginning of 1645; he mentioned his Roman meeting with Mersenne, claiming that he was not told anything about the experiments and that he did not know Torricelli's success; he read Galileo (1638), the Archimedes' work on scales, the description of hydrostatic balance of Tytus Liwius Burattini (1617; † 1681) from Krakow and the writings of Hieronim Pinoccio (* 1612 Lucca; † 1676) who served as a mayor of Krakow in 1645-1649, as the secretary of Jan Kasimierz and his deputy in the Netherlands and in England.⁴⁰⁰ Magni was visited by the noble Aleksander Mazzi in Warsaw, and in 1645 by the Jesuit Jan Baptiste Adrianus, who left his Roman studies of rhetoric to come to Warsaw.⁴⁰¹

³⁹⁸ Subotowicz, 1959, 74; Ogonowski, 1979, 188, 192; Anna Kołos, Battle of the „glass pipe”. Struggle between the „old” and „new” in the debate around experiments with vacuum dating to 1647. *Wydawnictwo Poznańskie Studia Polonistyczne*, 31/2017: 167-190.

³⁹⁹ Magni, 1959, 104.

⁴⁰⁰ Magni, 1959, 101; Ogonowski, 1979, 193.

⁴⁰¹ Magni, 1959, 104; Ogonowski, 1979, 195; Subotowicz, 1959, 55.

In July 1647, Magni performed his seven stages of the experiment in front of the Polish king and his court. In the second phase, he pressed the mercury tube with his finger, turned it around and poured it inverted into the water, which spilled over a small bowl with mercury in a wider container. He measured 74 to 76 cm high column of mercury in the tube. Magni removed his finger to let the mercury pour from the tube into the bowl, while the water filled the tube to the top, where previously above the mercury he noticed few centimeters of vacuum. In the same year he described his experiments in *Demonstratio*. In February 1647, similar experiments were performed by Pascal in Rouen. In his booklet *Vacuum pleno supletum* (1650), Magni added experiments with an oblique tube that he pushed towards the horizontal position so long until it ran out of an empty space at the top.⁴⁰²

Magni's first published his twenty-four pages long booklet in 1647 or 1648. He put the question in the first subheading, and then he started a controversy with Aristotle. Magni's narrations were supplemented with the quotation of Galileo's *Discorsi* (1638),⁴⁰³ and occasionally he also addressed his king and patron.⁴⁰⁴ He then put Aristotle's name in the title of Magni's three chapters with which he concluded the book.⁴⁰⁵

The important new thoughts about empty were the crown of disputes that dragged already over two millennia. The Jesuits had a vacuum for a kind of entity opposing itself. This was also felt by use of the Latin language term sounding like "thing without space". Galilean physics published in Italian vernacular could avoid such a semantic contradiction. The apparent puzzle was also denied by Magni's title of his own work "space without things in 1647."⁴⁰⁶ Experiments of Magni the Capuchin have been paved the way for modern vacuum theory. Since his experiments directly touched the ideas of Otto Guericke and his collaborator, Prince of Ljubljana, Janez Vajkard Auersperg, the other nobility of Carniolan were acquainted with Magni's ideas about the vacuum. That is why John Vajkard's brother supplemented their library in Ljubljana with Magni's book; the

⁴⁰² Magni, 1959, 83-86, 89.

⁴⁰³ Magni, 1959, 80.

⁴⁰⁴ Magni, 1959, 82.

⁴⁰⁵ Magni, 1959, 85, 91, 93.

⁴⁰⁶ Prager, 1980, 48.

writer-capuchin might gave a book to Janez as a gift.

Magni mostly resented the scholastic criticism after he refused Aristotle's denial of the vacuum. He wrote mainly against the Jesuit vacuum which served the Roman Inquisition networks of Honoratio Fabri (Faber, * 1606/7 Le Grand-Abergement between Lyon and Grenoble; SJ 1626 Avignon; † 1688 Rome),⁴⁰⁷ whose vacuum seemed to be still full of vapours of mercury, just like Kircher or Linus' voids. Fabri was extremely popular among the Jesuits of Inner Austria with Ljubljana included. H. Fabri made similar experiments with vacuum between 1639-1641.⁴⁰⁸

Magni mostly contradicted the scholastics with his criticism of the Aristotelian denial of vacuum. According to Aristotle, four basic elements should have a natural direction of movement upward or downward relative to its density. Unfortunately, there is no direction of movement of the empty vacuum⁴⁰⁹ since it doesn't have a density. One hundred years later, the Carniolan Jesuit and the Ljubljana Rector Anton Erberg reviled the long-dead Magni, who obviously fairly stepped on to the Jesuits. However, the times have changed as the following generations have accepted Magni's description of the vacuum. What's more: two centuries after the death of Capuchin Magni the vacuum became the basis of all modern technologies, from the bulb to the television screen.

5.3.4 *Marsenne Extends Knowledge of Vacuum*

The Minim Mersenne, in his monastic cell near *Place Royal*, through his vast enormous circle of correspondents, told the French about Torricelli's vacuum experiment. After Mersenne's death, Mersenne's correspondents enabled Colbert to establish the Parisian Academy of Sciences. Mersenne became famous with his equation for calculating the of prime numbers, which proved to be wrong for the large numbers, but nevertheless encouraged many researchers. Mersenne corresponded with the vacuum deniers Hobbes and Descartes about the movement and the vacuum. Mersenne doubted that Galileo tested any motions

of bodies down the inclined plane, but modern research has proved Galileo's reputation and his merits. In any case, Mersenne enabled the reception of Galileo's doctrine in the high society Parisian circles.

After returning from Florence and Rome in spring of 1645 Mersenne issued a report on Torricelli's experiment with a barometer in Paris.⁴¹⁰ On 13. 12. 1647 René Descartes reported to Mersenne in Paris that he had put the paper measure in front of Torricelli's type of barometer.⁴¹¹ The experienced glassworks were required for production of such glass devices; so, Mersenne could not repeat Torricellian or at least Valeriano Magni's experiment in Paris because he did not have enough skilled masters there; much better happened to Pascal in the province.

5.3.5 *Conclusion*

The Jesuits made from Aristotle's science a barrier through their refusing to recognize the existence of a vacuum. The Capuchins were free of such clashes, so they received more novelties, which were offered by the invention of the barometer. The Capuchin Valeriano may not have been the first at his barometer experiments, but he was at least very successful in exploring the properties of the vacuum. He also visited his colleagues in today's Slovene places on several occasions during his official duties, and thus he also relied on newly advanced approaches to vacuum techniques to the erudite Slovenes.

5.4 **Academic Ancestors of the First Carniolan Vacuum Researcher, Janez Vajkard, Prince of Auersperg**

5.4.1 *Introduction*

Janez Vajkard Auersperg (Johann Weikhard, * 11. 3. 1615, the castle Žužemberk; † 13. 11. 1677, Ljubljana) was born four centuries ago; 370 years

⁴⁰⁷ Cygan, 1989, 377, 427.

⁴⁰⁸ Subotowicz, 1959, 75.

⁴⁰⁹ Sparnaay, 1992, 12; Podolny, 1986, 21.

⁴¹⁰ M.J. Gorman, Jesuit explorations of the Torricellian Space, *MEFRIM* (1994), 106/1: 19.

⁴¹¹ Redhead, The measurement. In: *History of Vacuum Science and Technology* (1984) 31.

ago, he became the first successful vacuum enthusiast in the areas of modern Slovenia. He was an assistant and simultaneously wealthy patron of Otto Guericke. At the same time, he supported the Jesuit researcher of the vacuum Athanasius Kircher and the first Viennese translations of Francis Bacon. Guericke and Kircher's opinions on vacuums were opposite, but they collaborated anyway. Janez Vajkard Auersperg undoubtedly played a key role in the beginnings of a modern new science, and especially for vacuum techniques among Slovenes, as well as among their then northern neighbors. His phenomenon is typical Slovenian. Like the entire row of subsequent educators in Slovenia from Žiga Zois through Valvasor and Fran Levstik, Janez did not even have official higher education; on the other hand, his early successes within top diplomacy enabled him to take over the most prominent Viennese political positions and above all to develop contacts with pioneers of vacuum technology in his mature years. And the Slovenian specialty: the modern Slovenes can easily welcome the "baron" Valvasor or Baron Žiga Zois among their compatriots, while most of their professional comrades and role models with Prince Janez Vajkard Auersperg included were declared as foreigners, even though they were Carniolans or even their fellow Slovenes as they were no more alien to Slovenian networks than Zois or Valvasor. They all wrote and spoke a little Slovene and preferred Latin or German; of course, Janez was speaking the Slovenian only in the dialect; he certainly did not use today's Slovene letters for his writings. This duality of criteria will be especially funny in the eyes of Janez's brother, the governor general Wolf Engelbert Auersperg, the principal extra-school educator of the teenager Valvasor. Both Auersperg brothers would not be able to close their mouths from surprise if in one way or another they'll learn that Valvasor was today a genuine Slovene, but not the Auerspergs! The modern thinker can by no means avoid the feeling that it is the transfer of later modern qualities to the former generations: because the princes Auersperg were bitterly opposed to the Slovene parties in the 19th and 20th centuries, the current Slovene politicians unduly transposed their "faults" to four centuries earlier Auersperg's ancestors. Here, perhaps, we have a surprise for you, dear reader: it is not the Slovenian stock of the poly-historian Valvasor or Žiga Zois perhaps connected with the fate of their own genus. The decisive point is that Valvasor

family exist no longer in Slovenia, and the Zois family avoided the oppositions of Slovenian native supremacy policy? If we take a further step, would a possible descendant of the poly-historian Valvasor or Zois who would support foreign Germanization policy undermine the modern popularity of Valvasor's Slovenian stock or even the modern glory of his Glory? Valvasor really became popular among Slovenians on the national side, especially after his sons, because of his bankruptcy, went to the monasteries, and the offspring of their daughter enjoyed their bit of happiness abroad? In any case, it would be worth adopting at least the vacuum researcher Janez Vajkard, Prince of Auersperg, since he was undoubtedly Žužemberk native and Ljubljana used to be his home. In any case, his family lived in those areas of Turjak castle at least so long as the Slavic folks themselves.

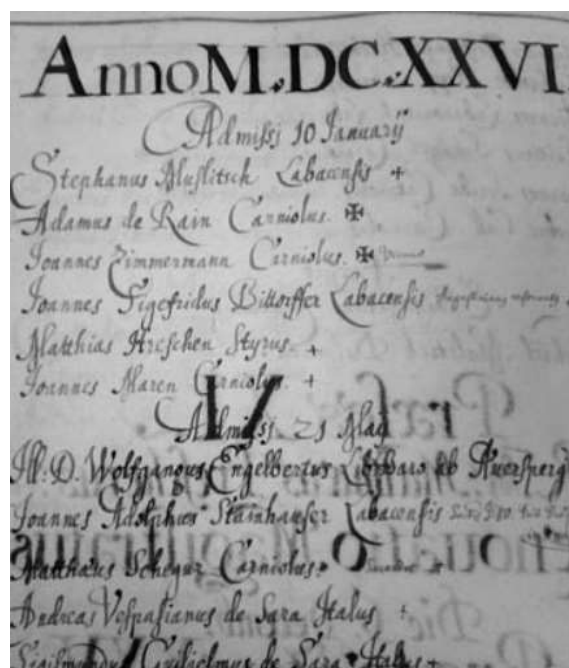

Figure 5-24: Volf Eglebert's entry into the upper Latin Marian congregation-society in Ljubljana on 21 May 1626 (AS 1073 II / 51r paginated 110).

5.4.2 Training during Studies

Janez Vajkard Auersperg was a member of highest Habsburgian nobility. Obviously, he did not study for an academic degree, but to socialize with the other future European rulers. Anyway, it might be interesting to name his teachers because they taught him Aristotelian physics which propelled his doubts in later Guericke's experiments.

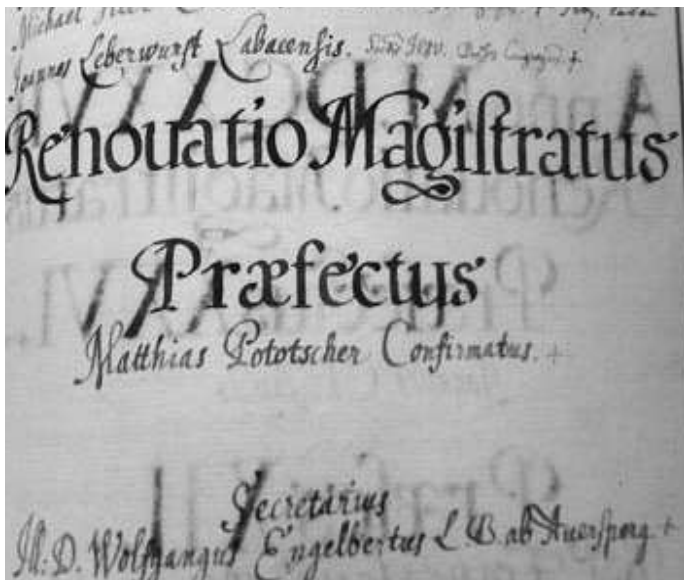

Figure 5-25: Volf Eglebert Auersperg as secretary of the Marian congregation-society in Ljubljana after 21 May 1626 (AS 1073 II / 51r paginated 111).

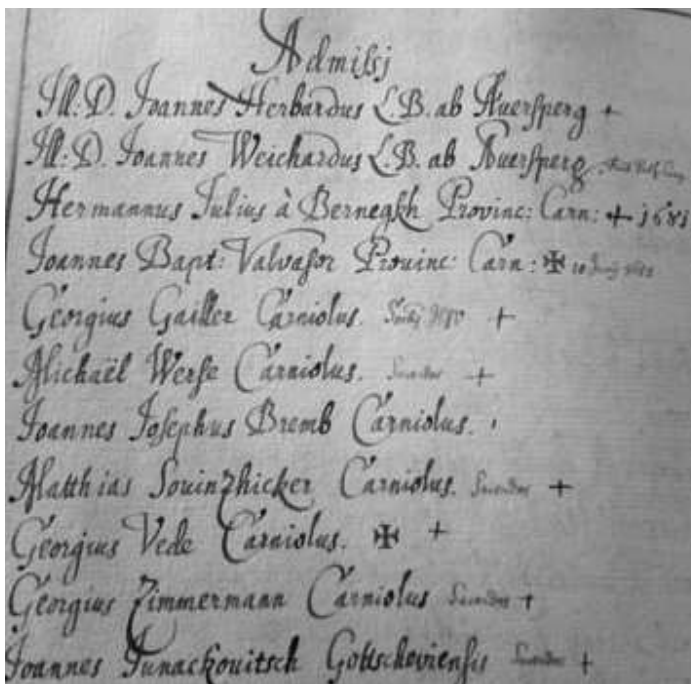

Figure 5-26: The entrance of Janez Vajkard and Herbard Auersperg into the higher Latin Mariean Society in Ljubljana in 1629 (AS 1073 II / 51r paginated 116)

5.4.3 Definition of the Time of Janez Vajkard Auersperg's School Days in Lower Schools

In Janez's times, the Jesuits of Ljubljana offered six years needed for the lower studies: initials, basics, grammar, syntax, poetics and rhetoric; for

the purpose of future priests, the Jesuits of Ljubljana also offered higher education studies in moral theology. Janez Vajkard did not complete his lower studies before the autumn of 1629, when he joined the higher (large) Latin congregation (Society) of the Assumption of St. Mary. He crossed over from the lower (small) Latin Congregation of the Queen of the Angels, which, however, has no preserved matrices. In 1628/29, a future vacuum researcher Janez studied syntax (higher grammar) as a member of the lower (small) Congregation of the Queen of the Angels, and therefore, in 1629, he entered the Latin higher Congregation of the Ascension as a future poetry student in the school year of 1629/30. It cannot be proven that the future first Slovenian vacuumist was included in the Congregation of the Death of Christ, which, despite of the earlier disputed beginnings, came to life well in 1660.⁴¹² Also, of course, as a high nobleman, he did not join the German bourgeois Congregation of St. Mary. In this discussion, we will discuss vacuumists' school days in Ljubljana in 1620s.

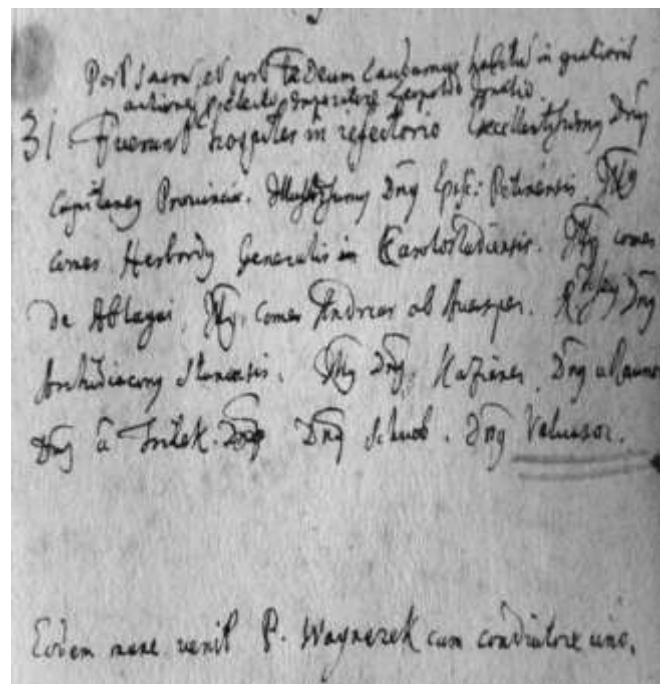

Figure 5-27: A record about the brother of the first Carniolan vacuumist, Karlovac General Herbard Auersperg, from the pen of the minister of Jesuit college as a writer of diary on the New Year day on 1. 1. 1654.⁴¹³

⁴¹² Lavrič, 2010, 274; ARS SI_AS 1073 II/53r.

⁴¹³ SI_AS 1073, I/32r, folio 64r.

Table 5-1: Students' years and congregational functions of Janez Vajkard Auersperg, his father, uncles, brothers, and first cousin

Name of Student	Studies (sources)	Professors of mathematical-physical topics
Janez's uncles Herbard and Vajkard	1587 Strasbourg ⁴¹⁴	
Janez's father Ditrih (Dietrich)	Strasbourg 1591? ⁴¹⁵	
Hербard, Vajkard and Ditrih	Tübingen 26. 8. 1592 as 469 th Austrian student ⁴¹⁶	Maestlin as astronomer
Janez's father Ditrih	Strasbourg 1593 ⁴¹⁷	
Hербard, Vajkard	Padua 1593 ⁴¹⁸	Galilei mathematician 1592-1610
Ditrih	Padua 1595-1596- ⁴¹⁹	Galilei mathematician 1592-1610
Janez's brother Volf	Ljubljana 1625- . On 21. 5. 1626 left lower for higher Latin society, Secretary of the Latin Marian congregation in 1626 ⁴²⁰	Pole Albert Ocicky was Rector in 1622-163.; In 1626, the Latin congregation was led by Matej Prešeren, and after his departure, by Francis Magerle. Professor of syntax was Gorizia native Nikolai Posarel in 1626, who in 1627 taught poetry
Volf	In Graz matriculated in Poetics on 9 February 1627. ⁴²¹ In Graz, in 1626/27 he continued his Ljubljana studies also with the study of ethics	In the class of Magister Stefan Keresztes (* 26 December 1600 Žitný Ostrov (Csallóköz) in Slovakia north of Győr) who taught poetry in Graz in 1627. Durand taught philosophy with physics in 1628-1630; the confessor Alex Rocha lectured on physics, and Kobav taught mathematics during Kobav's specialization
Volf	Venice, Padua, Bologna ⁴²²	During this time, Riccioli completed his studies of philosophy and then lectured in Parma
Volf	Vienna 1629? ⁴²³	Guldin was a professor of mathematics in 1623-1637
Volf	Siena 15 June 1630-; Higher studies and later also University studies ⁴²⁴	Gallaccini was a professor of mathematics
Volf	Cleve (Cleves) 1631? ⁴²⁵	
Janez's Brother Herbard	Enrolled in the great Latin Marian congregation in Ljubljana in 1629. Besides two prominent Marian congregations, the congregation of excellence	Lecturer of rhetoric was Aegidius de la Rovere

⁴¹⁴ M. Preinfalk, *Auerspergi*, Ljubljana 2005, 99.

⁴¹⁵ M. Preinfalk, *Auerspergi*, Ljubljana 2005, 99.

⁴¹⁶ M. Preinfalk, *Auerspergi*, Ljubljana 2005, 99, 111; H. Hermelink, *Die Matrikeln der Universität Tübingen*.

Nendeln/Liechtenstein 1976, 1:696; T. Elze, *Die Universität Tübingen und die Student aus Krain*, Munich 1977, 80.

⁴¹⁷ Elze, *ibidem*, 79, 80.

⁴¹⁸ Elze, *ibidem*, 79.

⁴¹⁹ M. Preinfalk, *Auerspergi*, Ljubljana 2005, 99; Elze, *ibidem*, 80.

⁴²⁰ Radics, 1865, L. Lukács, *Catalogi presonarum et officiorum Provinciae Austriae*, Roma 1982; Radics, 1865, SI_ AS 1073 II/51r, folios 110 and 111; Baraga, 2003, 104.

⁴²¹ Radics, *Der Verirrte Soldat*, Agra 1865; L. Lukács, *Catalogi presonarum et officiorum Provinciae Austriae*, Roma 1982, 2: 297; J. Andritsch, *Die Matrikel*, Graz 1977, 1:82 (no. 104).

⁴²² Radics, 1865, X.

⁴²³ L. Lukács, *ibidem*.

⁴²⁴ Weigle, 1962, 1:255.

⁴²⁵ P.P. Radics, 1885, 36; M. Bircher, The "Splendid Library" in: *The German Book 1450-1750*, London 1995, 286.

	"Christ, the victorious in the Eucharist" was in crisis under the leadership of Ditrh Auersperg ⁴²⁶	
Herbard	Munich 1630-23. 1. 1632-	Lower studies at the Jesuit college, then at the court ⁴²⁷
Herbard	Strasbourg 1631-21. 1. 1632 ⁴²⁸	Lower Schools ⁴²⁹
Herbard	Graz spring 1633-Autumn 1633 ⁴³⁰	Durand was a professor of mathematics in 1632-1654; Kobav taught mathematics during his specialization
Janez	In 1629 in Ljubljana president of the great Latin Marian congregation ⁴³¹	Head of the Congregation Aegidius de la Roiere (Royer), syntax lecturer Janez Popp as Graz student of Theology
Janez	Munich 1630-15 January 1632-	Lower studies at the Jesuit college, then at the court. Professor Franz Schildt, a doctor of both laws, taught him in Munich or Wurzburg ⁴³²
Janez	Strasbourg?	Lower Schools ⁴³³
Janez	Bologna Spring 1633-Autumn 1633 lower school ⁴³⁴	Riccioli was a teacher at university while Janez was also playing with his classmates the inflated ball game <i>Pallone</i> ⁴³⁵ probably Pallone col bracciale while the inflation might give Janez some ideas of Guericke's vacuum pump
Janez	Siena June/July 1635-1636: philosophy, law, maybe also some medicine studies ⁴³⁶	Professor Gallaccini; Galileo's visit to the Archbishop of Siena Ascanio (Ascano) Piccolomini, the brother of Ottavio and Eneo Piccolomini, lasted from 30 June 1633 until the end of the year
Janez's first cousin Andrej Count Auersperg (* 16. 7. 1615; † 8. 10. 1664)	Ljubljana leader of Marian congregation on 21 June 1651 ⁴³⁷	

⁴²⁶ SI_AS 10773 *Sodalitas* II/51r, Pagina 116 No. 1, Baraga, 2003 *Letopis (Yearbook)*, 107, 108, 109.

⁴²⁷ S. Sienell, *Die Geheime Konferenz*, Frankfurt 2001, 87; G. Mecenseffy, Im Dienste dreier Habsburger, in: *Archive für Österreichische Geschichte* (1938), 299.

⁴²⁸ Radics, Ernstes und Heiteres aus einer Cavalierbibliothek, In: *Bilder Oesterreichischer Vergangenheit und Gegenwart* (1885), 34.

⁴²⁹ Not mentioned by G.C. Knod, *Die Alte Matrikeln*, Nendeln/Liechtenstein 1976.

⁴³⁰ P.P. Radics, 1885, 36; IX Steklasa, Herbart X. Turjaški (1613-1669), In: *Ljubljana Bell (Ljubljanski Zvon)* (1881), 613 36; IX Steklasa, Herbart X. Turjaški (1613-1669), In: *Ljubljana Bell (Ljubljanski Zvon)* (1881), 613.

⁴³¹ SI-AS 1073 *Sodalitas* II/51R, Pagina 116 No. 1, . Baraga, 2003 *Letopis (Yearbook)*, 107, 108, 109.

⁴³² S. Sienell, *Die Geheime Konferenz*, Frankfurt 2001, 87; G. Mecenseffy, Im Dienste dreier Habsburger, in: *Archive für Österreichische Geschichte* (1938), 299-300.

⁴³³ No mention of him by Knod, *ibidem*

⁴³⁴ Not mentioned by G.C. Knod, *Die alten Matrikeln* 1976.

⁴³⁵ M. Žvanut, *Noble Stories*, Ljubljana 2009, 13.

⁴³⁶ Weigle, 1962, 1:263.

⁴³⁷ SI_AS 1073 *Sodalitas* II/51r, Pagina 31.

STAMMTAFEL HAUS MAGNI, LINE LURAGO MARINONE-COMO
ÄHNLICHEN UND GESCHWISTER VON P. VALERIAN



Figure 5-28: The count V. Magni's genealogy tree (Nicolaus from Lucca, Ludwig of Salice, 1976, 132/133, 186).

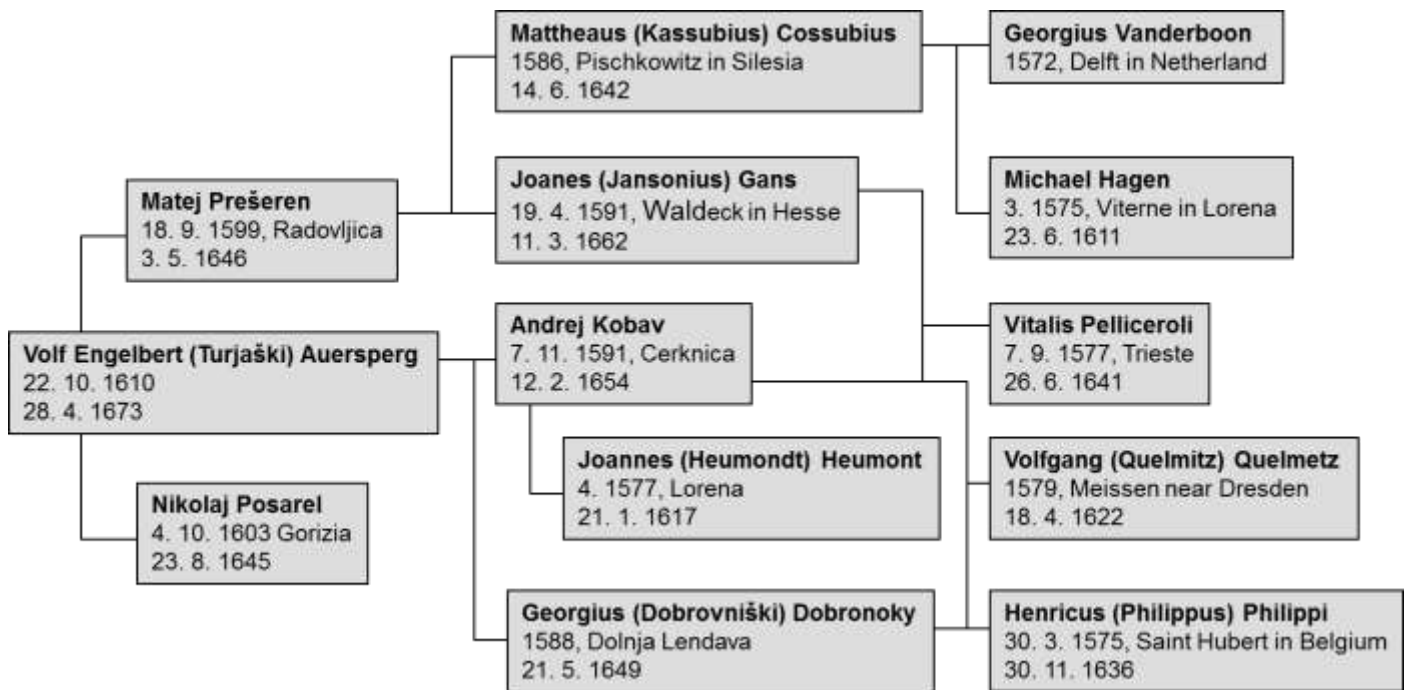

Figure 5-29: The academic ancestors of Volf, the brother of first vacuum researcher, according to his studies in Ljubljana. Among them were of Slovenian descent (at least) Prešeren, Posarel, Kobav and Dobronoky. The first note is the date of birth, followed by the date of entry into the society of Jesuits, studies (mathematics and physics), the completion of studies (shifted to the right), jobs and death (in the lower right corner).

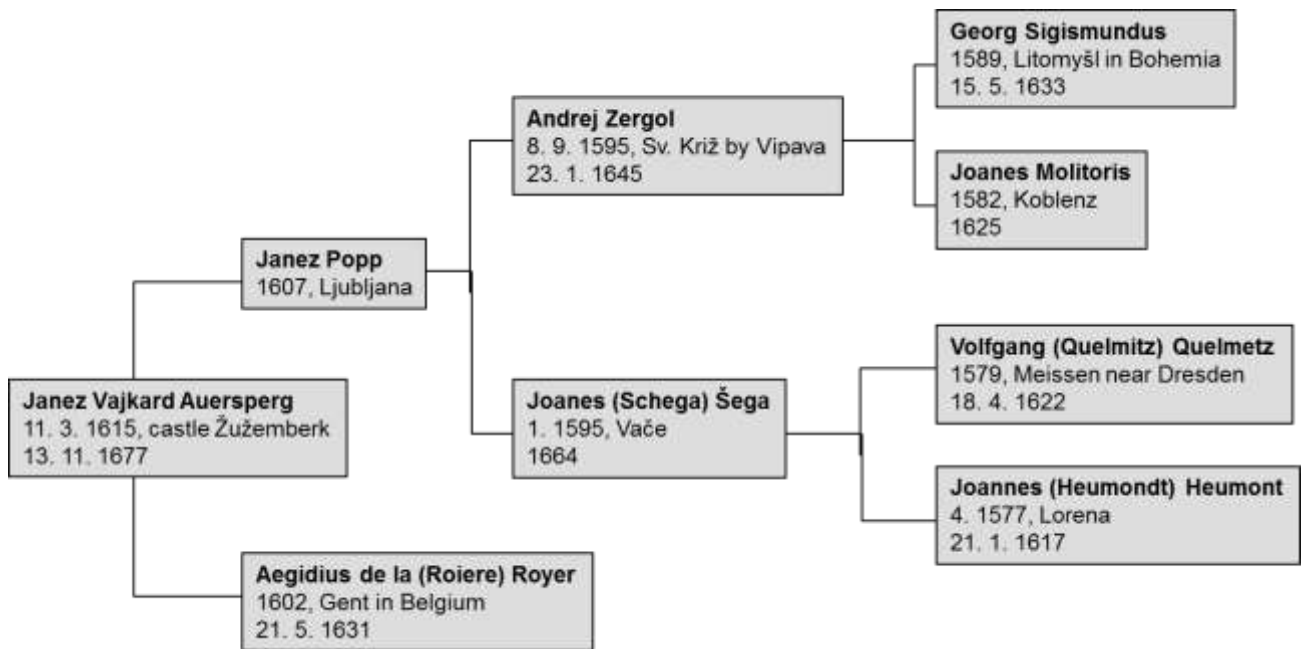

Figure 5-30: Academic ancestors of the first Carniolan vacuumist in relation to his studies in Ljubljana.

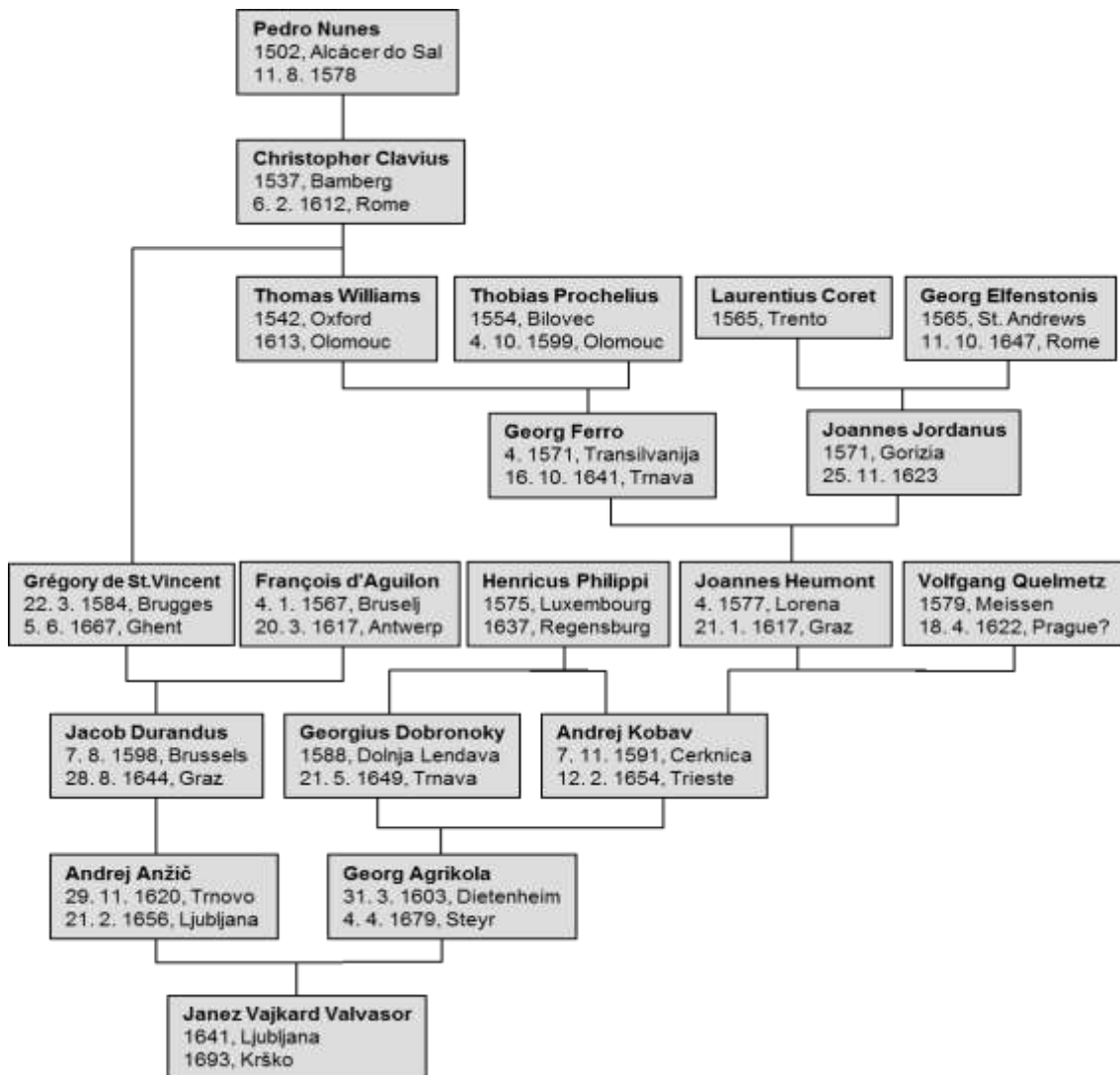

Figure 5-31: Academic ancestors' tree of prefect of the Ljubljana Lower School of Jurij Agrikola, who worked in Ljubljana during the time of Valvasor's schooling between 1653 and 1657; there are also the academic ancestors of his colleague Anžič.

5.4.4 The First Carniolan Vacuumist's Brother and his Friend Librarian Schönleben

As a son of Ljubljana mayor, Janez Ludvik Schönleben studied physics at the University of Graz in a class of a pupil Ch. Grienberger Hermann Horstus and Andrew Zergol from the Vipava Cross, who was also the student of Cerknica native Andrej Kobav. Schönleben's and Warmuet's mathematics professor Filip Müller (Philip, * 1613 Graz) also came out of Kobav's long-standing Graz school as a student of the Belgian Jacob Honorat Durandus and, above all, of the Pole Sigismund Mogilnicki. Philip Müller taught law and mathematics to the Emperor, and as his confessor serving between 1654 and 1676, the accompanied the Emperor's visit to Ljubljana on September 12, 1660;⁴³⁸ the high-ranking visitors were hosted by the first Carniolan vacuum researcher, Janez and his brother, the regional governor general.

The philosopher and librarian of Volf Engelbert Auersperg, Schönleben, was the prefect of the Ljubljana Jesuit lower school in 1650/51.⁴³⁹ At the end of his prefecture, on June 22, 1651, Schönleben led the Ljubljana celebration of the anniversary of the Battle of Sisak,⁴⁴⁰ which the 10-year-old Valvasor must have seen. Schönleben set up a school play named *Heresis fulminata*, followed by performances by the other patrons: the syntax lecturer Joachim Hating's under the title *S. Janchorus Martyr* in 1655, lecturer of rhetoric Andreas Anžič (Anšič) with a play about *S. Pancratius* (289-12 May 303 or 304 Rome) in 1655, and grammar lecturer Willibaldus Kogger with the tragic performance of *Maria Stuart, the Scotia Regina* in 1657 during Valvasor's schooling.⁴⁴¹

As a priest in Ljubljana, Schönleben also worked closely with the Jesuits after leaving the Jesuit society, as he was often quoted in the Jesuitical diary. He left the society of Jesuits only to be able to remain in Carniola after a nearly twenty-years of Jesuitical experiences; traveling to exotic lands

obviously did not please him too much, as it would certainly hinder his writing about Carniola. He was a frequent guest of the Jesuit college of Ljubljana where he encountered the teenager Valvasor. As a Jesuit in Ljubljana, Schönleben associated with a former Trnava physicist Harrer, who had just arrived in Carniola; together they visited Bled on 8. 6. 1651. Wilpenhoffer and Harrer visited Trieste together; Schönleben visited the Jesuit College of Ljubljana in May 1657, while Wilpenhoffer and Harrer visited Kamnik on 6 August 1657 and Kočevje on 20 September 1657.⁴⁴²

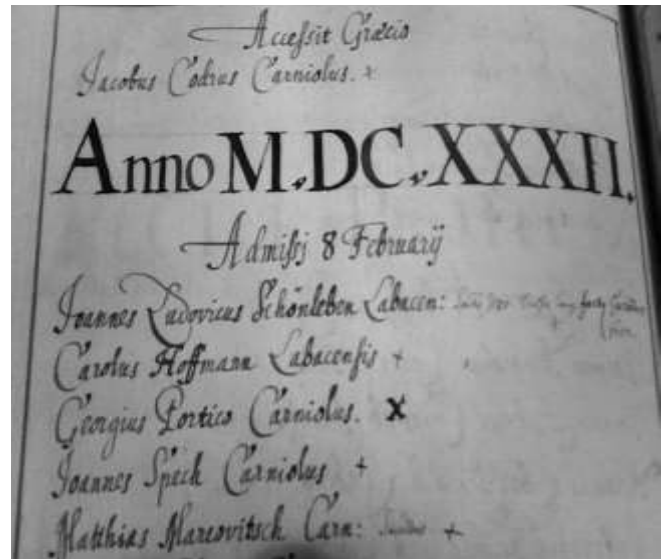

Figure 5-32: Schönleben became a member of the upper Latin Marian congregation-society in Ljubljana on 8 February 1632 (AS 1073 II / 51r paginated as page 122)

The well-dressed tables of the Governor-General Wolf (Volk, Volf) Engelbert Auersperg and his heirs were often attended by young Valvasor, Janez Danijel baron Erberg, brother of Valvasor's classmate Jurij Andrej Baron Gallenfels, Franc Hohenwart, Marko Grbec (Gerbec), the later provost Janez Krstnik Prešeren, and their older fellow Janez Ludvik Schönleben. From a fruitful exchange of opinions, even many fatal links have been coined: the owner of several books about vacuum, M. Grbec chose Ana Katarina Schwiz(en), the niece of Schönleben's nephew Janez Gregor Dolničar, for his second spouse.⁴⁴³ She certainly loved her groom's library full of vacuum data including Boyle's *Nova experimenta pneumatica respirationem spectantia* bind to Boyle's *Exercitationes de atmosphaeris corporum*

⁴³⁸ Baraga, *Letopis*, p. 214, Lukács, *Catalogi*, p. 678.

⁴³⁹ Dolinar, 1976, 203–204; Baraga, 2003, 167.

⁴⁴⁰ Reisp, 1983, 77.

⁴⁴¹ Dolinar, 1976, 61.

⁴⁴² SI_AS 1073, I/32r, folio 3v, 36v, 40v, 49r.

⁴⁴³ Smolik, Terpin, 74.

consistentium: deque mira subtilitate, determinata natura, et insigni vi effluuiorum in Bolognese edition of 1675.

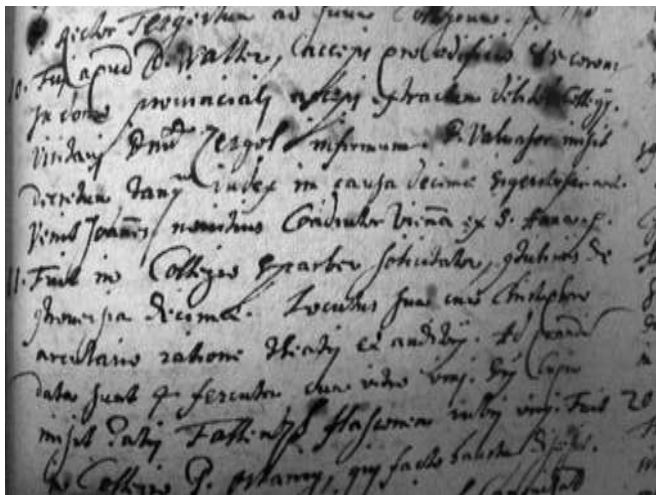

Figure 5-33: A note about the friend of the first Carniolan vacuumist, Valvasor, in the diary of the Jesuits of Ljubljana during the schooling of JV Valvasor on March 10, 1657. That's the only note about Valvasor in the Jesuit journals, which might have been related to Janez Vajkard Valvasor, since the remaining three notes dated during his school years clearly report on the celebrations attended by Valvasor at headquarters of the Jesuits of Ljubljana together with other nobles of Carniola, and thus obviously referred to one of the older Valvasors. Ljubljana native Franz Zergoll von Zergollern (1613-4 May 1657 Ljubljana) as the husband of Felicita and the father of Franc Wilhelm from the later Gruber's castle Področnik (Mali Rožnik, Rosenbüchel), donated 500 guildens to the Jesuit of Ljubljana at the end of Valvasor's studies in 1657/58,444 so the record probably refers to him. The record does, however, only report 85 crowns in connection with the provincial's fees and the weakened Zergol who died two months later. Valvasor is listed in relation to index and tithe. Immediately after Valvasor, Joannes was listed as a promoter of lessons of novices at the Jesuit Church of St. Anne in Vienna.

Wolf's palace looked like the then modern Italian academy; in fact, Wolf's young friends became the embryo of the academy Operosorum, founded in the year of Valvasor's death.⁴⁴⁵ Many of Wolf's close friends were Academics Operosorum, such as Franc Hohenwart with the academic name "Innubus". On the other hand, Schönleben joined

⁴⁴⁴ Dolinar, 1976, 130; Baraga, 2003, 200, 206.
⁴⁴⁵ Kmecl, 2005, 11.

the Bolognese Academy of Gelati, like his nephew Janez Gregor Dolničar later in 1679. Janez Gregor Dolničar even enrolled in the Roman Arcadians in 1709.

The chief charm of the Wolf's Baroque table was certainly his rich library. At Wolf's time, at least Schönleben and Valvasor used it, which is why they soon gathered their own rich book collections.⁴⁴⁶ Similarly, Janez Danijel Erberg, son of Auersperg customs officer from the Knežja Lipa of Kočevje region, was the grandfather of the Chinese astronomer Hallerstein and great grandfather of one of Carniolan most important owners of collections of books and antiques the baron Jožef Kalasanc Erberg; Janez Danijel had over 650 books.⁴⁴⁷ Valvasor's Bogenšperk played a similar role in the space of time between Wolf and the Enlightener Žiga Zois, although the local hospitable Bogenšperk network was not based solely on the well-being of the domestic library due to rural remoteness, domestic printing works and a collection of technical devices.

On 21 May 1626 the provincial governor general Volf (Wolf) Engelbert Auersperg became member and then secretary of the senior Latin Mary Congregation in Ljubljana, a few months after his transfer to the Catholic faith;⁴⁴⁸ until then, he was Protestant, as his ancestors of Auersperg family were the main supporters of their subject Primož Trubar. Of course, Wolf's conversion to the Catholic faith was necessary, since as a Protestant he would not be able to study in Graz at all. On 9 February 1627 he continued his studies of poetry in Graz as the 104th student named Wolffgangus Engelbertus L. Baron ab Auersperg Dominus in Schemberg at the class of lecture master Stefan Kerezstes. The Bohemian Kerezstes studied philosophy with mathematics and physics in Olomouc, so many of his academic ancestors were numerous Bohemians and Poles, as Joannes Cadlovius. Among the most important academic ancestors of Volf Engelbert Auersperg, according to his Graz studies, was the Karst native Janez Rafael Kobenzl, whose family has climbed up primarily through diplomacy as undoubtedly one of the most important in the empire. Contrary to the Auersperg's family, Kobenzl's family mostly

⁴⁴⁶ Kovač Artemis, 2005, 56.
⁴⁴⁷ Štuhec, 2005, 120; Lubej, 2005, 51.
⁴⁴⁸ Radics, 1865, X; SI_AS 1073 II/51r, folio 110, 111; Baraga, 2003, 102, 104; Andritsch, 1977, 1: 82, no. 104.

remained faithful to the emperor's Catholicism. In 1627, the prefect of Wolf's Lower School and the dean of linguistics was the Gorizian professor of physics Vincentius Amigoni (Amigoli). In 1657, the son of Wolf's cousin with the same name Volf Engelbert Auersperg studied rhetoric and later philosophy in Graz.⁴⁴⁹

Wolf continued his studies in Venice, Padua, Bologna⁴⁵⁰ and Vienna. He completed his schooling in Siena at the class of mathematician Gallaccini after matriculation on June 15, 1630, like his younger brother, the prince Janez Vajkard Auersperg, who was able to listen to the lectures of famous astronomer and researcher of the gravity Riccioli. Janez' three years younger acquaintance Bolognese noble Grimaldi joined the Jesuitical society in Bologna on 18. 3. 1632, met his lifelong friend Riccioli there in autumn 1633 and later discovered diffractions of light. Among Gallacini's and Riccioli's classmates was also the famous Jesuit researcher of magnets and meteorology Niccolò Cabeo, whose book was bought by Valvasor.⁴⁵¹ Their teacher was a friend of Galileo, Giuseppe Biancani, who studied under supervision of the professor Markantun de Dominis. According to Newton's opinion, De Dominis was the main explorer of the rainbow; Dominis later left the Jesuit society, became a Senj-Modruš bishop, and then a Split archbishop. During his prolonged visit to the Protestant England, he was quite fond of Newton's predecessors. At the same time, he fell into the complicated wheels of the Inquisition, which, after his death, burned his books and remains on December 21, 1624, at a time when Volf Engelbert Auersperg still attended lower studies in Ljubljana.

5.4.5 *Wilpenhoffer Helps his Religious Co-brother Kircher's Correspondence with Carniolan Pioneer of Research of Vacuum*

After his studies among Italian scholars, Volf, returned to Ljubljana as a leading Carniolan politician. He supported his domestic Jesuits all over again. In contrast to the Jesuit mathematician

Kobav or the Prague mathematician Gottfried Alois Kinner of Löwenturn, the Jesuit of Ljubljana Wilpenhoffer sent to Kircher only the local scientific information that Kircher skillfully used in his descriptions of Carniola. Kircher never saw Carniola in person even though he was not far from it, since his journey from France to Rome could have ended in Vienna, where he was supposed to replace Kepler as an imperial mathematician in 1633. Wilpenhoffer also took care of the spreading of Kircher's works among the Carniolans, especially in favor of the regional governor Wolf Engelbert Auersperg. A few months after the release of *Mundus Subterranei* (*Structura globis terrestris, Iter Extaticum II*), on 24 October 1658, Wilpenhoffer reported to Kircher about the desire of the "Count, our lord" to have that book. In fact, Wolf's librarian Schönleben entered Wolf's bookplate in the title page of that book in the same year 1658.

Wilpenhoffer supplemented Kircher's knowledge of Carniola; Kircher initially did not mention either Idrija or Cerknica Lake in his book, although he reported on the waters between the Alps and on silver and minerals below them in the Alpine Hydraulics chapter.⁴⁵² He described the Danube river⁴⁵³ in more detail and discussed the properties of mercury.⁴⁵⁴ Wilpenhoffer reported to Kircher on a mercury mine, without naming Idrija; he noted that they also have a "fossil silver" wire there. In relation to the mine, he quoted Casati's book *Ex Ligna*, which was one of the books of the Jesuit Paulo Casati or the earlier work of the other Jesuit Albert von Curtz (Curtius, pseudonym-anagram Lucius Barrettus, * 1600 Munich; SJ 1616; †19. 12. 1671 Munich). Casati's *Geometricum problema ad lineas cuicumque rectae datae aequidistantesc* was published in Milano in 1602. Kircher paid special attention to the lake "near the place called Cerknica", which completely sinks underground and allows plowing over the dried field and even the hunting. Over time, the water from the bottom again bursts its banks and flooded the fertile field within the pond. Kircher relied on Wilpenhoffer's instructions.

Eleven years later, Wilpenhoffer wrote again to Kircher from Ljubljana to Rome on 28 November 1669. The letter was shrunk on the bottom; the last

⁴⁴⁹ Andritsch, 1977, 1: XVII, XIX, XXVII, 80, 82; 1980, 2: 103.

⁴⁵⁰ Radics, 1865, X, XVII.

⁴⁵¹ Valvasor, 1995, 199.

⁴⁵² Kircher, 1657, 185–186.

⁴⁵³ Kircher, 1657, 162.

⁴⁵⁴ Kircher, 1657, 202.

half of report was written in much smaller letters, as if Wilpenhoffer was not supposed to start the other additional page on another leaf. He first mourned the death of Karl Watoser, probably their common Jesuit acquaintance outside the Austrian

province, and then reported on two parts of Kircher's *Ars Magna sciendi seu combinatorica* under the abbreviated name *Ars combinatorica*. This book also inspired Wolf "Count the Excellency the

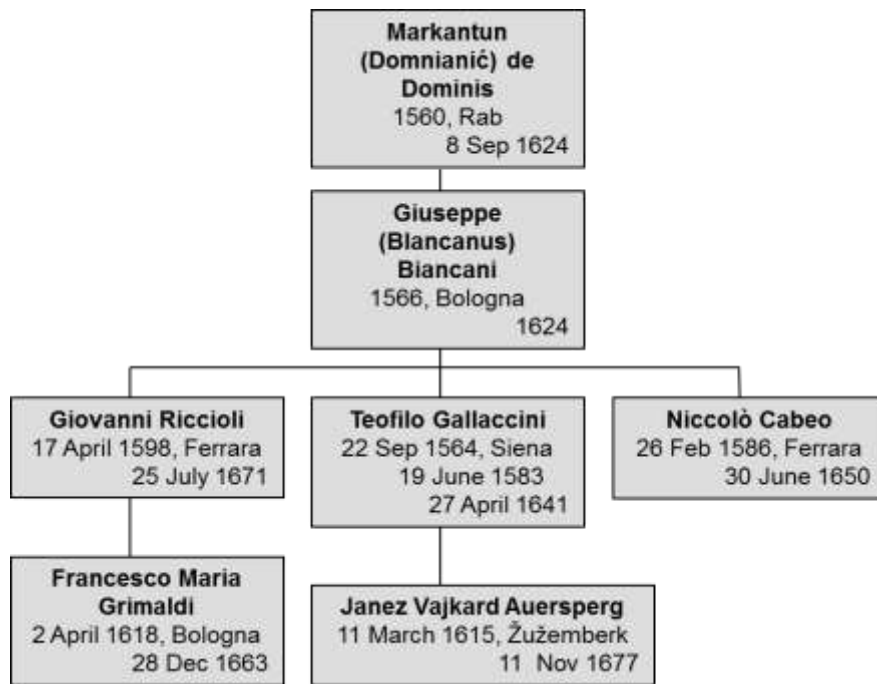

Figure 5-34: Academic ancestors of the first prince Janez Vajkard Auersperg according to his study in Bologna

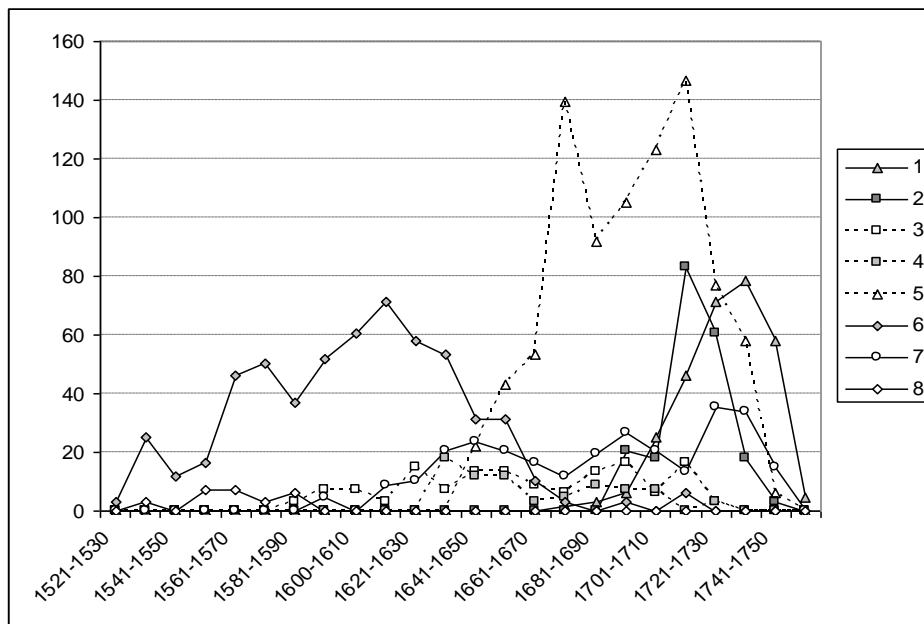

Figure 5-35: Changing the ideas of physics of the 1480 Jesuit professors of mathematics and physics from the Austrian and Bohemian provinces plotted along the decades of their births. (1 Bošković's supporters, 2 Cartesians, 3 Aristotelians, 4 Riccioli's North Italian networks; 5 Newtonians including the Jesuits Paul Hansiz (1645-1721) and E. Vols, 6 Clavius' networks including the Belgians D'Aguillon, Tacquet, Theodorus Moretus, 7 The researcher of vacuum Kircher and his students Lana and Casati, 8 Kircher's collaborators)

Governor of the Province": only recently he was elevated to the title of the Excellency as the new Imperial Secret Councilor. Wolf received that work printed in Amsterdam in 1669, and Schönleben catalogued it into a professional group of linguistics. Contrary to other three Kircher's books, in *Mundus Subterranei* and *Ars combinatorica* Schönleben did not note that it was a gift from the writer. This may mean that Wolf had to buy both prints; Wilpenhoffer certainly acted as a facilitator.

Kircher explored Carniolan waters without visiting those places. He never saw Lake Cerknica,⁴⁵⁵ but used notes of his fellow Jesuits as Kircher's Museum in Rome was a gathering place for all kinds of Jesuit discoveries and reports. Before Wilpenhoffer, the greatest Kircher's Inner Austrian reporter was his fellow Jesuit Sigismund Siser (Siserius, Siserus, * 1.

5. 1636, Klagenfurt; SJ 7. 10. 1653, Leoben; † 29. 12. 1693, Vienna). Kircher reprinted Siser's letters in his *Iter extaticum II Qui et Mundi Subterranei* (1657),⁴⁵⁶ which almost forced Wilpenhoffer's additional reports on Idrija and Cerknica for the later release of Kircher's *Mundus Subterraneus*.⁴⁵⁷

After he joined the Jesuits in 1653 and spent his novitiate years in Leoben in 1655-1656, Siser may have stayed among the Jesuits of Ljubljana, although without official office. In 1656 he voted for the Jesuits of Ljubljana 800 gulden from his legacy; the Carinthia provincial States general, in fact, sent out 500 golden dinars from this account to the Jesuits of Ljubljana in 1658. Siser's attachment to the Jesuits of Ljubljana was also the result of a fall from the horse of the Ljubljana student of the casuistic Janez Siser (* 1 July 1608; † 1636) from Velikovec (Völkermarkt) in Carinthia near Klagenfurt, who died in the Ljubljana college on the day of the birth of his relative Sigismund Siser. Between 1657 and 1659 S. Siser studied at Kircher's class in Rome,⁴⁵⁸ so, he brought fresh news about Carniolan attractions to the Eternal City. During the years 1670 and

⁴⁵⁵ Kircher, 1650, 9th book, 2nd part, 7th paragraph; Schott, 1677 4th book, 2nd part, 518–533, 554–555; Habe, Kranjc, 1981, 20–21; Gruber, 1781 *Briefe*, 110; Korošec, 1967 *Beseda dve*, 12, 21.

⁴⁵⁶ Kircher, 1650, 9th book, 2nd part, 7th paragraph; Siserius, *Epistola ad R. P. Kircherum, in qua hydria sive fodina argenti vivi in Carniola describitur* in Kircher, 1657, part, 173; Schott, 1677, Liber IV pars II, 518–533, 554–555.

⁴⁵⁷ Kircher, 1665, 9th book, 2nd part, 7th paragraph.

⁴⁵⁸ Baraga, 2003, 196, 294; 129; Lukács, 1988, 1554–1555.

1673, Siser lectured on ethics and philosophy in Vienna.

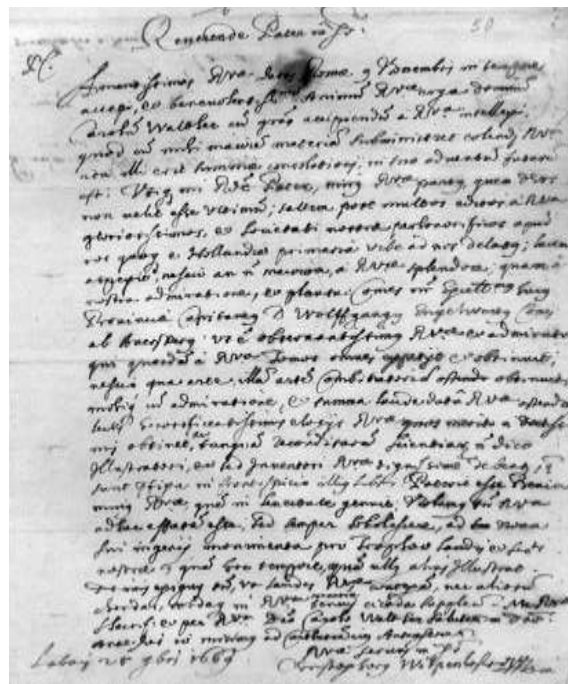

Figure 5-36: Wilpenhoffer reports to Kircher about Wolf's praise of Kircher's book *Ars combinatorica*⁴⁵⁹

Among seventy-five Jesuitical master's and priests of Valvasor's school days in Ljubljana there were altogether five teachers of mathematics (7%) and 16 professors of physics (21%); among them twelve (16%) published their works (Francis Menegatti, Janez Rover, Kobav, Montegnana, Souttermans, Schönleben, Preischaff, Dillherr, Söldner, Jelenčič, Lindelauf, Rainer). Only the first four wrote also on physics and mathematics, among them in Celje resettled Ljubljana native Montegnana. Montegnana wrote about the square of the circle, magical quadrangles and other entertaining problems in four chapters⁴⁶⁰ at the time when he was still in charge as the confessor of the deposed minister Prince of Auersperg. Valvasor did not acquire the books of the Jesuits of Ljubljana who taught there in his schooling times, except the works of Schönleben and Friderik Jelenčič, who both left the Ljubljana college in the summer of 1652.⁴⁶¹ Apart from Hermann, Jelenčič, Schönleben, Montegnana and Kobav, Dolar was the only one among the Valvasor's professors of Ljubljana noted in Valvasor's book *Glory (Slava)*, except for his list of rectors. Of course, Valvasor

⁴⁵⁹ APUG 559 folio 50^r. Courtesy university Stanford..

⁴⁶⁰ Valvasor, 1689, 4/6: 353, 8: 742.

⁴⁶¹ Valvasor, 1995, 416, 659–660; Jelenčič, 1662.

also mentioned some of the other Carniolan Jesuits among his list of local writers.⁴⁶²

5.4.6 *The Confessor of the First Carniolan Vacuumist*

The confessor of the first Carniolan vacuumist, the noble Montegnana, was a kind man, a trusted collaborator of his patron Janez Vajkard Auersperg. He was among the most famous of his species. The confessor of Auersperg, the Jesuit Ferdinand de Montagnana (Montegnana), was the grandson of Trubar's archenemy Polydor Montagnana († 1604) and the son of Severus (* about 1579; † before 1602). His cousins were the Jesuits Francesco Harrer and Janez Jakob Harrer, sons of the Preddvor castle owner Felicitas Montagnana and the court judge Sebastien Harrer of Carniola. Polydor became a noble member of the Carniolan province Estates General on 3 June 1592 in Gorizia; eight years later he donated organ musical instrument worth 400 golden coins to the Jesuits in Ljubljana and in 1605 he founded a scholarship for two students. Trubar was the subject and friend of the ancestor of the first vacuum researcher Auersperg, who would surely be surprised by the vacuumist's choice of confessor after Polydor proved to be so hostile in his times.

Ferdinand de Montegnana completed his lower school in Ljubljana by studying rhetoric in 1615/16. With the recommendation of the Ljubljana Rector the Pole Nikola Jagniatovius (Jagniatovič) on 27 December 1616, he was accepted to the Graz seminary of Ferdinandeum, where he studied mathematics at the university together with Andrej Zergoll on 3 January 1617 and on 3 February 1617. Next year 1617/18, he studied physics in Graz. In 1619/20 he studied rhetoric in Vienna in the class of Viennese Ferdinand Mengenhauser (Mengerhauser) together with Andrej Tullius Bernardini from Ljubljana. While their three classmates continued mathematical-physical studies in Graz, the Jesuits sent Montegnana, Bernardini and Graz native Valerio Schörckel to Italy. Thus, between 1620 and 1622, Montegnana was educated at the Jesuit college in Sicilian Messina, where in his times the legendary Greek Francesco Maurolico (* 1494; † 1575) taught. Francesco Maurolico was the son of the Constantinople guy who did not love their new

Ottoman rulers there. The Benedictine Maurolico, along with other Byzantine fugitives, presented to the Europeans the ancient Greek language, thus paving the path for the vacuum experiments of Torricelli and his heirs. Among the publishers of Maurolico's works were the Roman mathematician Ch. Clavius, Giovanni Giacomo Staserio (* 1565; † 1635) and Vincenzo Carnava († 1615) from Messina. At the time of Montegnana's education, Galileo, with his Copernican stance, began to oppose the Vatican's mighty men, after being cruelly crushed by the Jesuit astronomer and architect Orazio (Horatio) Grassi. Immediately after completing the study of mathematics-logic, physics and metaphysics, Montegnana returned to Ljubljana together with the Istria native Leonard Bagni (* 1593, Pazin; † 1650, Zagreb) as a lecturer of the first classes in Ljubljana, full of impressions of the new Italian sciences, the beginnings of vacuum technique and quarrels about the motion of the Earth. Montegnana's older companion Bagni finished his studies in Rome. Perhaps, this was precisely why he carefully dictated his lectures to his graduate student of physics Graz native Jurij Winkler, in which he adhered to Aristotle's guidelines in dealing with the vacuum in 1628. When Montegnana occupied the Ljubljana teaching position for the third time, after the Emperor's death on March 23, 1637, he performed a famous festive speech in the Ljubljana cathedral, which he printed in Graz on 44 pages and dedicated his first pages to three young brothers, the Counts of Auersperg: the future regional governor Wolf Engelbert, the prospective General Herbert and the future prince of the vacuum experiments, Janez Vajkard. His contribution was addressed as: *Oratio Funeris ... Labaci ... Ferdinandi II.* That oratorical performance opened his door to the diplomatic work of Janez Vajkard Auersperg, who was just then preparing a peace treaty after a devastating Thirty-year war. Thus, in 1642 Montegnana was sent to Spain to accompany the imperial mission. In 1661, as a prefect of the Ljubljana School, he wrote reports for the provincial.⁴⁶³ He was precisely the kind of priest whom the vacuumist Janez Weikard (Vajkard) needed; shortly after the end of his experiments with Otto Guericke with a vacuum pump in Regensburg in 1654, Janez wished to use Montegnana's experience with Italian science and

⁴⁶³ SI_AS 1073 II/51r, p. 78; Baraga, 2003, 37, 90, 97, 217; Lukács, 1982, 681–683; Dolinar, 1976, 61, 124, 172, 192; Korade, 1998, 137; Andritsch, 1977, 50, 218, 240.

⁴⁶² Valvasor, 1689, 2/6: 353, 357, 358, 359, 365, 367, 8: 713.

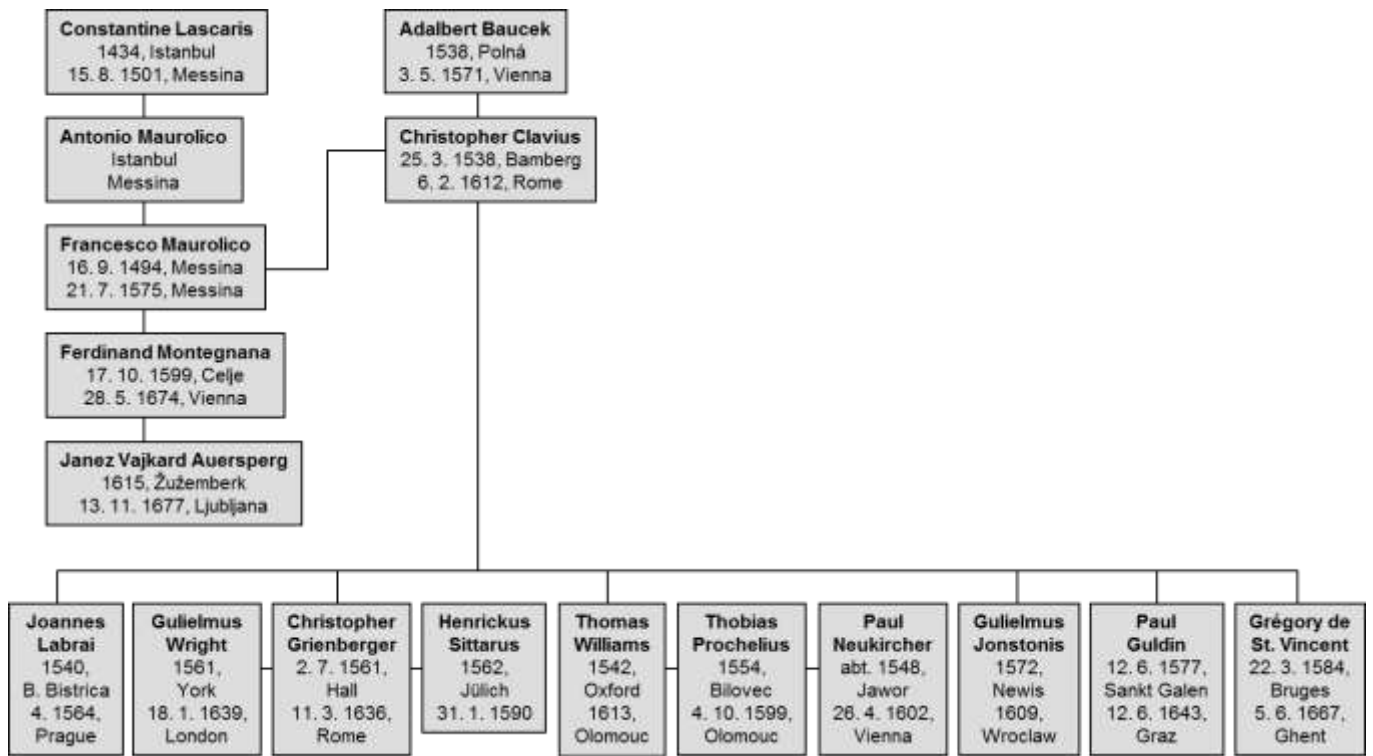

Figure 5-37: Montegnana and the Byzantine academic ancestors of the first Carniolan vacuum researcher, Janez Vajkard Turjaški (Auersperg).

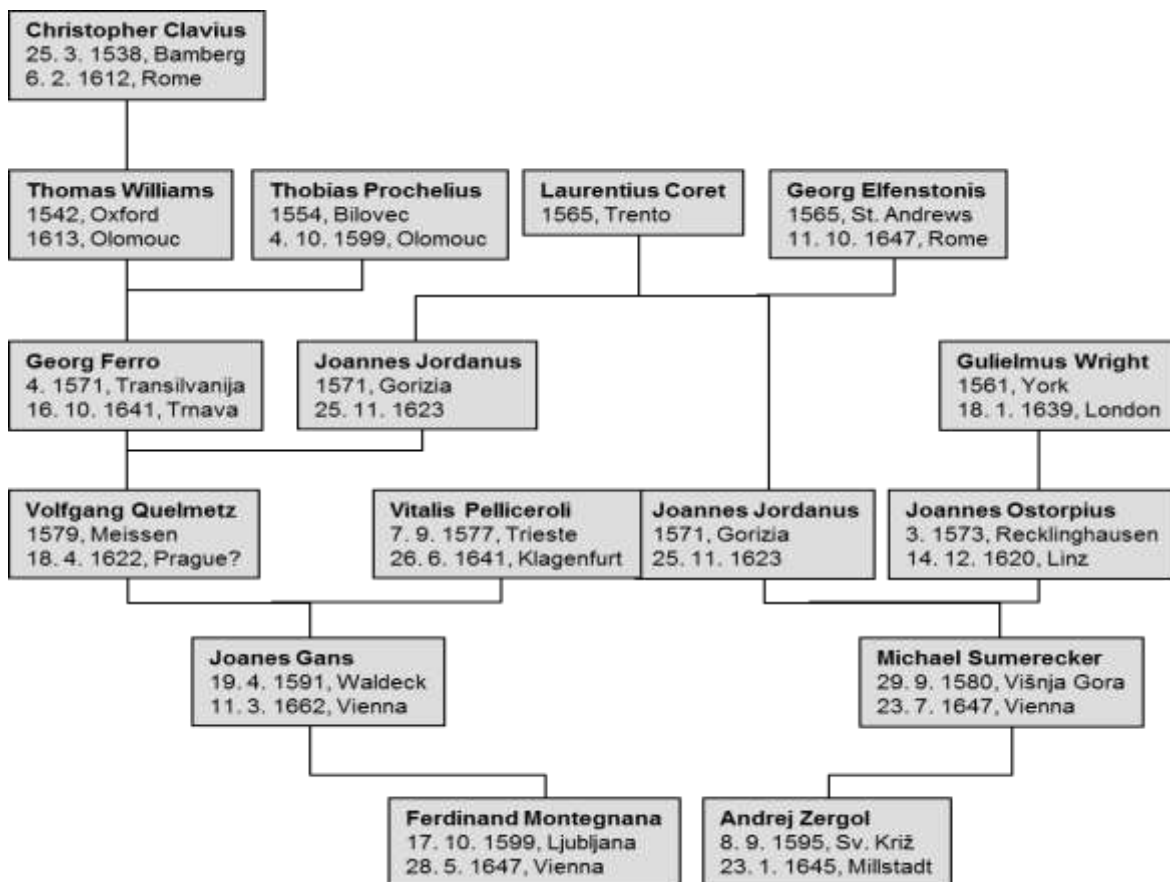

Figure 5-38: Academic ancestors of Montegnana and Zergoll by Their Graz Studies in Logic-Mathematics

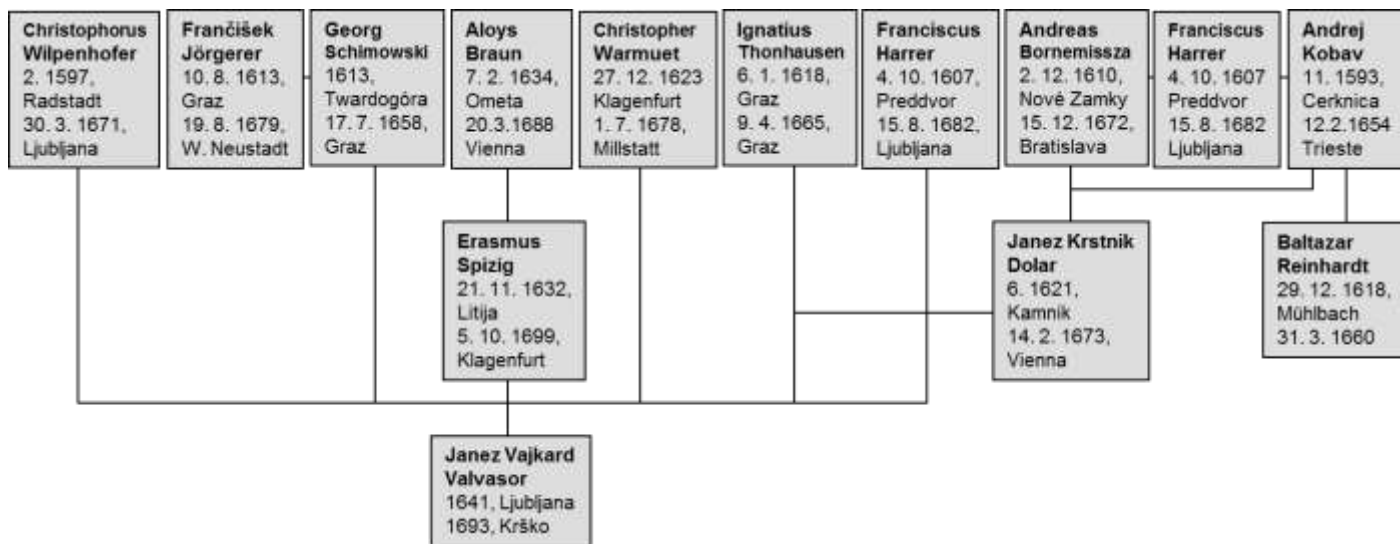

Figure 5-39: The Jesuit teachers in the time of the studies of the namesake and coworker of the first Carniolan vacuumist, renowned Janez Vajkard Valvasor

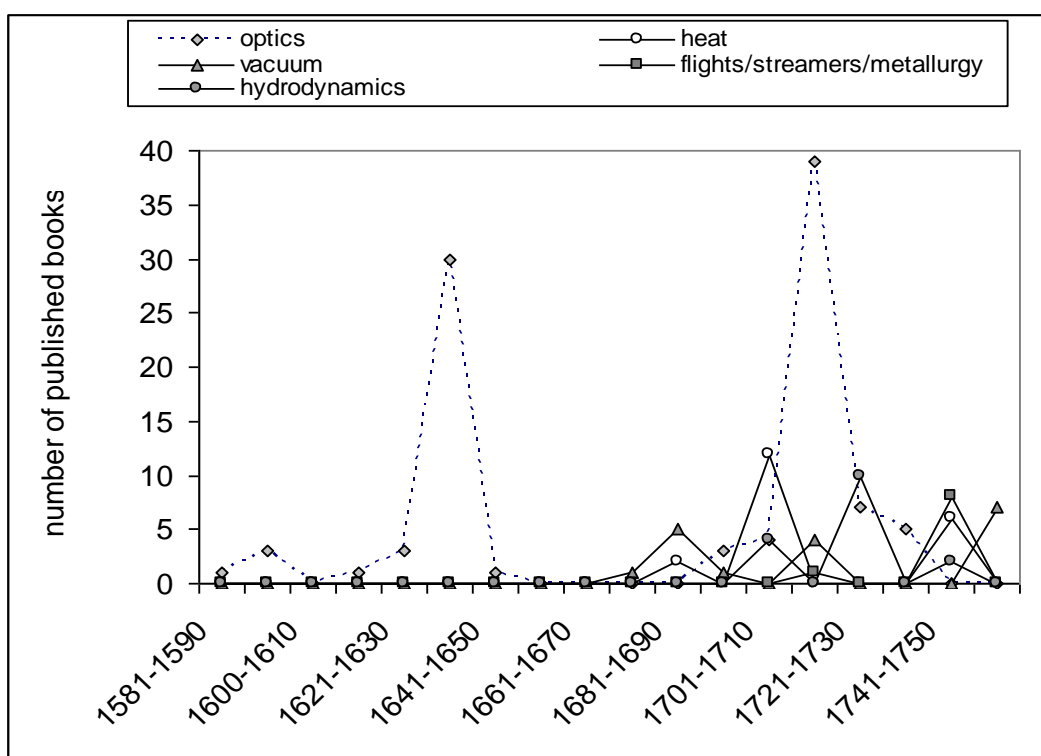

Figure 5-40: The number of published books about physics authored by the Jesuits of the Austrian and Bohemian provinces, out of a total of 601. Among them, thirty-six were authored by the Jesuits who taught physics and / or mathematics in Ljubljana.

chose him as his personal confessor in 1664. Their cooperation was mainly about science, until the prince vacuumist fell of the imperial favor in the last weeks of the year 1669. He soon had to return to his Carniolan home, where Montegnana did not dare to follow him. Nevertheless, in 1673, Montegnana published anonymously his joint

designs about the squaring of the circle. The only well-known edition with a similar title is attributed to the bibliophilic count Bernard Ignätz Martinitz (* 1603; † 1685).⁴⁶⁴

⁴⁶⁴ Valvasor, 1689, 2/6: 353. Baraga, 1999, 103 and Simoniti, 1972, 89 put the year of printing 1637 to Graz or to Ljubljana.

The prince vacuumist Janez replaced the absent Montegnana in Ljubljana with the local Jesuit teachers of his children. First, in 1674, he selected the Viennese professor of Logic Karl Boranga (* 1640; † 1684), a former student of Tolmin native mathematician Janez Krstnik Cruxilla (Križanič), who had just returned from Madrid. Karl has spent his last five years as a missionary after Janez Vajkard Auersperg's death. Initially, he converted the natives of Mexico as the precursor of Marko Kappus, and then sailed to the Philippines and to the Mariana Islands. After Boranga, Janez chose his own namesake Austrian Nexinger (* 1641

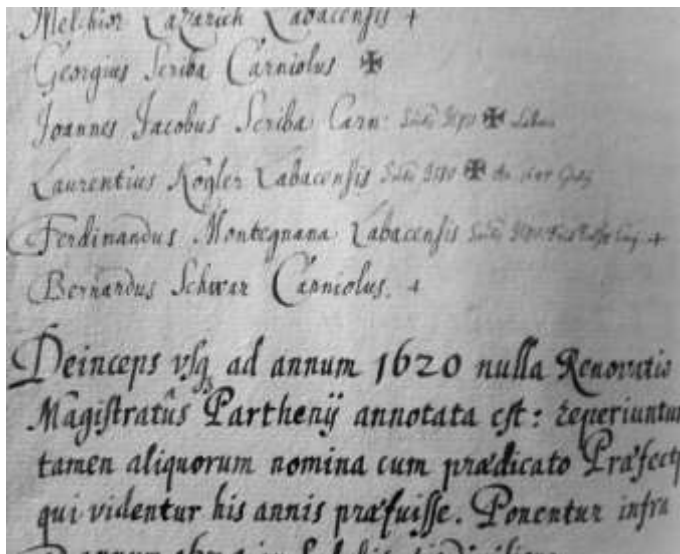

Figure 5-41: Record of the entry of the future confessor of the first Carniolan vacuum researcher Ferdinand de Montegnana to the High Latin Marian congregation-society under the chairmanship of professor of rhetoric Valentin Koch (Cochio) from Duderstadt, east of Göttingen, on 8 September 1614 (AS 1073 II / 51r pp. 76, 78). Two other younger future Jesuits, Montagnana's two years younger guy from Ljubljana Lovrenc Kogler and the Škofja Loka native Janez Jakob Scriba, entered the society together with Montagnana. A note was promptly added upon Montegnana's three-year later entry into the Jesuits' society and on the conduct of congregations. Valvasor also had him for a Ljubljana native in contrast to more relevant records that considered the subsequent relocation of the Montegnana's family to Celje.

Schwanenstadt in Upper Austria; † 1729) as Auersperg's home teacher in 1675/76. Nexinger used to be a student of Solkan mathematician Philip Ceferin (Zeferin, Čeferin). Following the

prince's death, Nexinger lectured on physics in Trnava and Zagreb. Nexinger was able to present the newest advances in vacuum techniques at Janez Vajkard Auersperg's Ljubljana palace. The ideas related to vacuum which circulated in Ljubljana of the prince Janez Auersperg's era were mainly connected with the vacuum balloons that Kircher's student from Brescia, Francesco Lana Terzi, described immediately after Janez Vajkard Auersperg's return to Carniola.

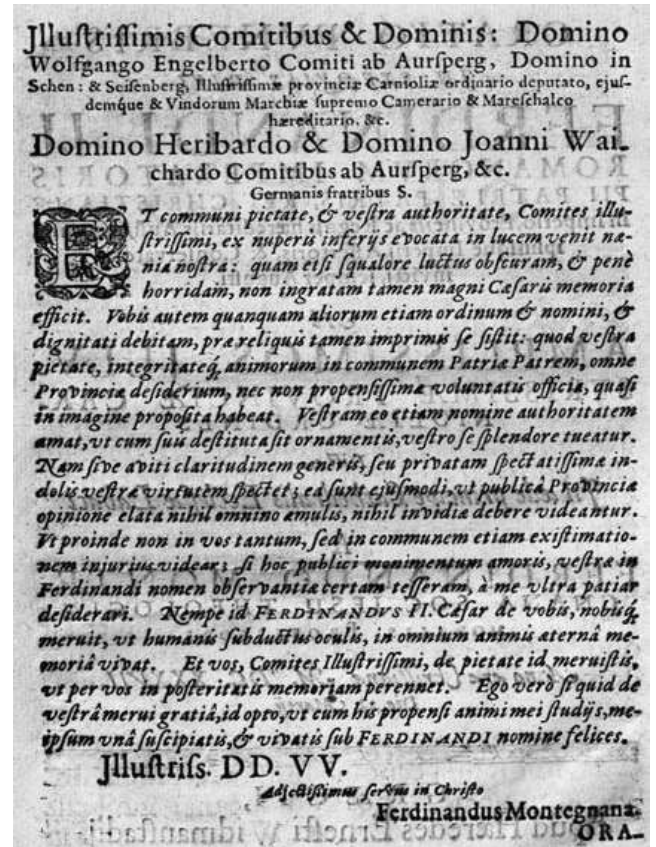

Figure 5-42: Montegnana's dedication to the first Carniolan vacuumist, Janez Vajkard Auersperg and his brothers to gain their confidence in Montegnana's printed edition in 1637.

5.4.7 Conclusions

The schools do not merely appear to be an important part of the human being and life. In fact, they define it as deeply as ever, once upon history even more than now, when the world's web is becoming a rival to the teachers of blood and meat. The future vacuum researcher, Janez Vajkard Auersperg, soon left his Ljubljana's school benches. On the one hand, the wider continuation of his studies could be an obstacle to his political journeys to the wider world. On the

other hand, Ljubljana did not even have enough higher schools for him.

5.5 The First Vacuum Pumps among Slovenes

5.5.1 Introduction

In the modern world, vacuum is part of our everyday life of food or lighting; therefore, vacuum pumps are also numerous. Of course, this was not the case many centuries ago, since vacuum pumps were the most expensive machines in the European world of the inventions for decades. Three centuries ago, Hauksbee's manufactures began their mass production in London and later Musschenbroek's enterprise in Leiden joined them; soon the prices became more accessible. Where and when did the first vacuum pump run on today's Slovenian territory?

The question provides by no means easy answer. The traveling of books is much easier to follow than the export of machines. Books have always been the high-valued commercial merchandise, so that the officials always took care over their resale. A rare careless person will reject the book, because everyone knows that it can be sold with a profit. But we treat the machines differently: so long as they work, they are used, when we can replace them with more efficient ones, we are happy to discard them. The old machines did not have value on the markets until recently and today we are barely trying to protect the industrial heritage as an important instructive memory. In preserving their industrial heritage, the Croats are one step further than the Slovenes, since Rijeka with an effective Pro Torpedo association and other neighbors' cities try to transform their former industrial plants into memorials from which new technological solutions could be learned.

The history of technologies is by no means free from problems; however, there are many more collections of old books in the world than museums of once important, but now unmanaged machines. Therefore, it is much easier to find out when a single basic book about vacuum techniques arrived in Ljubljana, rather than guessing when Slovenians first started a vacuum pump on their home soil for their pioneering

time. Despite the difficulty of researching, let's try to get that tough nut resolved for our readers!

5.5.2 *Guericke's Inventions among Slovenes*

The prince from Ljubljana, Janez Vajkard Turjaški (Auersperg) was the main Guericke co-worker and critic. Of course, his money was not lacking, and his elder brother, Volf Engelbert, was the wealthiest guy in city of Ljubljana. The Auersperg Brothers placed in Ljubljana the best private library in those days. In their palace on the premises of the modern NUK, they also had a special room full of strange foreign curiosities, as was usually the case among wealthy educated guys; in the wilderness of later centuries, this pleasant tradition has been lost for good. Naturally, visitors to Ljubljana did not miss the opportunity to watch their famous collection. Thus, we have kept quite a few descriptions of Auersperg treasures. Auersperg's Rubens was particularly honored because he hung at least one of Rubens's art in the palace, and of course, the other Carniolans also kept Rubens's works, among them the later Jožef Kalasanc Erberg in Dol,⁴⁶⁵ the grandson of Janez Vajkard Auersperg's customs officer. Some wall and ceiling paintings were made by the renowned artist Almanach from Antwerp in the Auersperg's Palace in Ljubljana around the year of the death of Janez Vajkard Auersperg's brother Volf.⁴⁶⁶ Valvasor kept Dürer's "Samson Kills the Lion" of 1496/1497 in a later print, made around 1600.⁴⁶⁷

Janez Auersperg's elder brother Volf bought Rubens's book on architecture published in Antwerp; but it is not entirely clear from the librarian's record whether he owned one or the other Rubens' books published there in 1652; he almost certainly got both. Rubens was also honored at the Academy dei Lincei of Galileo, as his disease was treated by the member of academy Johannes Faber (Fabro).⁴⁶⁸ In the halls and fifty-two living rooms of his palace in the middle of Ljubljana, Auersperg exhibited a portrait of emperors Ferdinand III and Leopold I next to the painting of Rubens, the chronicles of

⁴⁶⁵ Kidrič, 1926 Erberg SBL, 1: 164.

⁴⁶⁶ Murovec, Klemenčič, Breščak, 2005, 205.

⁴⁶⁷ Ubel, 1955, 9, 50.

⁴⁶⁸ Freedberg, 2002, 283–284.

the success of Emperor Charles V and many oriental valuables; he covered the marble floor with Turkish and Persian rugs, and he spread the Dutch Gobelins along the walls. At the front of palace, he arranged a garden with southern fruits like lemon-trees and orange-trees as the climate used to be much milder in those days. In the room of treasures, he had war trophies, paleontological rarities and even a hand of mummy. The inventory of the palace together with forty-eight paintings was compiled in the register of the first Auersperg prince, the vacuum researcher Janez Vajkard, in 1677,⁴⁶⁹ and again at the handover among his grandchildren in 1762. The building was especially admired by Emperor Francis Joseph during a visit to Ljubljana in July 1883.⁴⁷⁰ Unfortunately, none of the contemporaries of the first prince of Auersperg and his brother mentioned any vacuum pumps in the Auersperg 'princes' palace. Guericke's performance of the device was not only extremely expensive, but it was also characterized by obesity and weight. Such a machine would, of course, catch the eyes of the people of Ljubljana, and so one can find only one reason for the silence of visitors about a possible vacuum in the Auersperg Palace; despite of friendship with Guericke, Janez Vajkard did not bring the vacuum pump to Ljubljana.

Janez Vajkard Valvasor learned his skills as a young nobleman during his visits to Wolf Engelbert Auersperg's fests. When he finished the main part of his world-wide tours, he arranged the premises and library in Bogenšperk according to the Auersperg's Ljubljana model. Was Guericke's, Boyle's, or even Huygens' vacuum pump among his castle treasures? Hardly. In any case, it is not among Valvasor's legacy, recorded in his last home in Krško.

Like Valvasor, Janez Danijel baron Erberg learned a lot in the palace of Wolf Engelbert Auersperg, including his first reflections on science. Erberg's great grandchild, Jožef Kalasanc baron Erberg, in many ways repeated the political path of the first prince Janez Vajkard Auersperg, as Jožef Kalasanc was also the educator of pretender to the throne in Vienna. Later, he suddenly returned to Carniola. In today's beautifully preserved pavilions in Dol, Jožef Kalasanc decorated the library and the first

museum in Carniola. He adorned his library with an educative note above the entrance and saved a lot of the vacuum-related book on it - did he store a vacuum pump in the neighboring museum pavilion? His son-in-law sold most of Erberg's books to Rudolfinum which is today's National Museum in Ljubljana. The peculiarities of the museum from the neighboring pavilion were scattered by all sorts of the winds. While we are maintaining the Erberg's library catalog, the list of objects from the former Erberg's Museum in Dol is not available.

5.5.2.1 The Vacuum Fun in Carniola

The prince Auersperg had enough money in his treasures; maybe he got Guericke's pump, which was the biggest and most expensive scientific instrument of the time? Perhaps at least some small vacuum preparations have been brought to his Ljubljana mansion? He certainly did not buy the first pump from 1648 or that from 1650, which was used by Schott, but he could supply the pump from 1662. Several pumps were only available after the fall of Auersperg's Viennese policy. The humiliated Auersperg prince with his wife and his seven children went to Wels, and then to his Ljubljana home in Carniola. During his frequent hunts he cooled the anger over the fading of his happiness and entertained himself with scientific studies. On July 7, 1669, he bought from the Prince Janez Anton Eggenberg the Inner Carniola manors of Snežnik and Lož and took over the Postojna manor. In 1623 Cluverius described the Postojna cave as a "big cave with the effervescent river in the hollow hill by Ljubljana". This and his other works were known to Carniolans, as they were offered as many as five Cluverius' books in Ljubljana in 1678.⁴⁷¹ The humanist Cluverius has established himself with geographical research of antiquity and the Middle East. After his long journeys in Germany, Italy, France and England, he befriended Thomas Bartolin and lectured at Leyden University, where Guericke studied immediately after Cluverius' death.

At that time, the Postojna cave had already been visited and the folks studied underwater flow of Pivka river "even a mile far". Therefore, the curious gentleman Auersperg of the "benevolent

⁴⁶⁹ Žargi, 2002, 282; Radics, 1885, 28.

⁴⁷⁰ Radics, 1885, 227, 28, 29; Radics, 1878, 54.

⁴⁷¹ Mayr, 1678, 71–72.

memory", as a new owner of Postojna, undertook his own research. In 1673, he lowered one of his paws on the ropes to the water in the river under the thick natural bridge in the Postojna Cave. The farmer was an apprentice fisherman equipped with fishing nets, since the economical Auersperg was particularly attracted by speculations about the underground animals that he was reading in Agricola's works. A man used the single-rope technique for his descent. He skated on a rock during a slow downhill and finally came to the water. His aides enjoyed some funny chatting and did not do too much to pull up their researcher quickly or safely. They were very pleased when he finally climbed back to the bridge and brought a pike, a carp and a clone in his net. The fish were not specially reared, but more like skinny. Auersperg was nevertheless satisfied and wanted to repeat his observations during the next day. He again offered the man a crown for his effort. However, the stubborn farmer did not want to go to the deepness again, even if Auersperg wished to give him the entire Postojna manor. He refused any further cooperation: "I will not tell about anything what I have seen and heard; but I will even not tell why I do not want to go down anymore!" He was so convincing that nobody knew how to help the prince, not with the word, nor with a sword. Further research had to be abandoned, since new volunteers wouldn't do it either, of course. Thus, one of the first planned Carniolan modern experiments ended quite laughable.

In 1679, a year and a half after Auersperg's death, Valvasor found the elderly cave fisherman and tried to find out the details of the famous underground experiment from him.⁴⁷² Unfortunately, this man again did not want to say anything useful. From his behavior, Valvasor assumed that the scarecrow was displayed in the cave. Valvasor was assisted by the Provincial Governor, Prince Janez Sigfrid Eggenberg, who in the meantime took over the Postojna manor. Valvasor worked closely with him and devoted to him a map of Croatia at the beginning of the 12th book of his *Glory (Slava)*. At that time the owner of the nearby castle Jama (Luege) near Postojna was the Count Janez Filip Cobenzl (Kobenzl), the grandson of the brother of the mathematician-rector the Jesuit Janez Rafael Cobenzl.

As Cobenzl (Kobenzl), Auersperg also became a fan of the local Jesuits. In 1674, together with his relatives and sons, Auersperg attended a dinner in the suburban Jesuit house in Ljubljana. He paid the costs of a whole banquet; when they were extensively served foods and drinks, the servants took the tables away and provided some entertainments, while the prince gave the great presents to everybody. The Jesuits of Ljubljana were also supported by the descendants of the princes. On the day of Jesus' circumcision in the winter of 1st January 1682, the son of the deceased first prince, along with the other highest nobles, attended a feast at the Jesuits in Ljubljana and vigorously supported the beginnings of scientific and higher education in Ljubljana.

After the death of his unmarried brother Volk Engelbert Auersperg, the prince inherited his estate. A week before his death, the prince brought together the manors of Poljane, Kočevje, Višnja Gora, Belaj, Žužemberk and the prince's manor into the trust (fidejkomis), which only the firstborn of the family could inherit. His descendants thus became the largest landowners of Carniola, but the real center of their wealth was in the Bohemian Sudeten Lands.

The Prince of Auersperg introduced the enthusiastic Carniolans with the beginnings of a vacuum technique in the empire and told them about some other jolly gossips of court intrigues. During the hunt he told his helpers, his subjects and the nobleman about the unusual properties of the emptiness. His stories fell to the fertile ground, as well-known among his listeners were Lienhardt Panian, Anne Panian and Jurco Panian from the Tanča Gora and Dragovanje Village of Bela Krajina in southern Carniola. Their descendants are today among the leading Slovenian vacuum researchers.

For his hunting and local politics, Auersperg needed loyal Carniolan nobles. The service of the prince was best used by the Verderber family employed as the customs officers at the Prince's Leiden Tree (Knežja Lipa) in the Kočevje lordship. After that manor was taken over by Volk Engelbert Auersperg, the Verderber family got their noble ranks. Since name "von Verderber" sounded a bit embarrassed, they renamed themselves into "von Erber" and finally to von Erberg. With a welcome Auersperg's support they

⁴⁷² Reisp, 1983, 144.

soon grew up too wealthy for Kočevje (Gottschee) manor and gradually moved their business to Ljubljana areas. The Kočevje native Janez Danijel, later baron Erberg, grandfather of Avguštin Hallerstein, was one of the main prince's helpers. The Auersperg prince told Erberg and other associates in course of hunting games and a pleasant glass of local wine about the wide world and about fashionable vacuum experiments.

The Erbergs imitated their benefactors in the purchase of scientific literature. On January 2, 1680 Anton's uncle, Franc Jakob Erberg, bought and rebuilt the house on today's Old square number 9 in Ljubljana and arranged a rich library in it. Since all his children died, the house and the library with many books about the vacuum were inherited by his half-brother Janez Danijel Erberg,⁴⁷³ who continued to enjoy the support of the Auersperg princes in Ljubljana. Prince Janez (John) Weikard was succeeded by his oldest son who, shortly after his father's death, married a countess from the mighty Herberstein family in 1678. In the meantime, Erberg's library grew and soon almost surpassed its model in the nearby princess castle (Figure 5-43). Karel Dežman bought at least part of the Erberg library for the National Museum in Ljubljana of today, but the Auersperg's Book Treasures were mostly sold to the American libraries in 1982. The auction in London took part without much of the Carniolans, who, of course, already had too much vacuum in their pockets.



Figure 5-43: One of the last photographs of the Prince's castle in Ljubljana, recorded after the earthquake in 1895

⁴⁷³ SBL, 1: 162.

In 1791, the Auersperg princes received a ducal title and with it they achieved the privilege to mint their own money in the Duchy of Kočevje inside the duchy of Carniola. Auersperg's customs officer Erberg have also progressed and successfully jumped into the high society circles. After the first Prince of Auersperg educated the Crown Prince Ferdinand IV, the descendant of his former tax collectors, Baron Jožef Kalasanc Erberg became the educator of the Crown Prince Ferdinand I in the spring of 1809. Unfortunately, Ferdinand I was not overly glittering on the Habsburg sky while ruling from his imperial throne.

5.5.2.2 Boyle and Hooke: Exploring Vacuum in England

In addition to other Europeans, the English researchers in the middle of the 17th century also discussed their empty spaces. The most famous English thinker of experimental science, Bacon, wrote about the vacuum. Unfortunately, King Charles II did not support the research of vacuum as the patron of the Royal Society (RS) organized in November 1660 at the Gresham College and officially established two years later. As early as on 1 February 1662, the king ridiculed "weighing the air of the Greshams". "Weighing" or "blending," that is, determining the density of the air which to all uninitiated must have seemed a serious waste of time. The density of the air was already measured by Galileo in 1613, however he got about twice as high result than a modern one.⁴⁷⁴ Later they measured more precisely, since they were able to determine the difference in weight up to 6.5 g in the 17th century.⁴⁷⁵

On 6 May 1653, a physician from Halifax and a later Fellow of the Royal Society (FRS) Power performed measurements like Pascal's on a hill Beacon by Halifax.⁴⁷⁶ The experiments were later repeated by Ball, Towneley and Boyle at the top of the church in Westminster. In January 1658, Boyle read about Guericke's experiments in Schott's book from 1657, and he repeatedly wrote to Schott.⁴⁷⁷

⁴⁷⁴ Sparnaay, 1992, 17, 37; Nichols, 1999, 133; Schaffer, 1993, 113.

⁴⁷⁵ 1 grain.

⁴⁷⁶ Middleton, 1964, 59–60.

⁴⁷⁷ Shapin, Schaffer, 1993, 167, 235, 275.

Robert Boyle was born in Ireland as the seventh son of Count Richard. He studied at home and traveled throughout Europe until 1645. During his trip to Geneva, he was supposed to "turn to experimental philosophy". From 1654 he lived in Oxford, where the open coffee shop Tillyard's hosted the advocates of "experimental philosophy" in 1656. In July 1660, Oldenburg began to work closely with Boyle and his nephew. In 1660, Boyle moved to his sister's household in London, but he still frequently stayed for longer periods in his house at Oxford. During the plague in 1664, he led the RS in Oxford. He helped to establish RS, and edited the Phil. Trans. In April 1668, he finally moved to London and actively participated in the RS. In 1680 he was elected president of the RS, but he did not accept the position. In addition to chemistry and physics, he also studied and wrote about theology.



Robert Boyle (*1627; † 1691)⁴⁷⁸

As Pascal a decade before him, Boyle had also developed his vacuum experiments at Oxford within a broader research of the properties of liquids. Pascal's barometric experiment of Puy-de-Dôme was repeated in Boyle's laboratory. As Guericke's competitor, Boyle developed three vacuum pumps. The first two of them were assembled by Hooke. The London-based device manufacturer, Greatorex, was trying to improve Guericke's pump. However, according to Hooke,

⁴⁷⁸ Bogoljubov, 1984, 47; Schaffer, 1993, 236, 259, 289, 297, 314.

his device was too large for useful handlings. At the end of 1658, Boyle agreed to develop a pump with Greatorex and Hooke, who had been his assistant for a year. Hooke has compiled his model called "pneumatic machine or air pump".⁴⁷⁹

Robert Hooke was born in the priest's family on the island of Wight. He studied at Westminster and at the Oxford University, where he and his relative Dr. Christopher Wren were under fatherly protection of John Wilkins, who was the first secretary of the RS along with Oldenburg. In 1655, Hooke moved to Oxford, where Wilkins later recommended him for the post of assistant to Boyle. From 12 November 1662 Hooke was an administrator of experiments with the RS and thus the first professional scientist in Britain. In 1664, he became a professor of geometry at Gresham University, where he lived until his death. On 11 January 1665, he was promoted to a life-long guardian of experiments in the RS, whereby, after Oldenburg's death, he was also secretary and editor of Phil. Trans. between 1677 and 1683. Hooke contributed to the development of many sciences: physics, horology, physiology, geology, astronomy, meteorology and architecture.



Robert Hooke (*1635; † 1703)

In 1660, Boyle listed the experiments performed in the previous two years with the first Hooke's

⁴⁷⁹ Nichols, 1999, 22, illustration after page 86.

piston pump⁴⁸⁰. Among the main critics of Boyle's results were Linus and later Newton's Teacher Henry More (1614-1687), a Platonist from Cambridge. More, like Hobbes, rejected the essence of the experimental program of the RS. The members of RS Wallis, Flamsteed and Hooke defended Boyle from Before More's criticism. Zucchi thought that the vacuum above the mercury column was still full of mercury (vapours), which was accepted by Casati, but not by Gassendi and Valeriano Magni.⁴⁸¹ The name mercury for quicksilver was hilariously linked with the name of the Roman god, who was supposed to be the protector of the thieves, and therefore smuggled over mercury in the form of invisible vapour, at least the critics of vacuum thought so. The name barometer was coined by the French statistician, Varignon.⁴⁸²

In the end of the year 1660 and on 30th May 1667, Boyle showed the operation of his pump to the beautiful opponent of animal testing Margaret Lucas Cavendish, Duchess of Newcastle-upon-Tyne (1623-1673) and the Tuscan archduke on their visit to the Gresham College. Immediately after the new year 1661, the Society, which changed its name a year and a half later in the RS, asked Boyle to bring a pneumatic machine and show the fellows his experiments. Hooke and Boyle simplified pumping by using the iron rack and pinion device to push the piston up and down. They did not like the large amount of water which Guericke needed to seal his device. They used lubricating taps machines and valves, which had to be manually opened and closed. The wooden piston was lifted and lowered through the bronze cylinder. To ensure good sealing, a "piece of tanned show-leather" was placed between the piston and the inside of cylinder. Their machine ointment was a mixture of olive oil and other vegetable juices boiled together with PbO. They added a little kitchen salad oil to lubricate a cylinder, valve and a round glass vacuum receiver.⁴⁸³

On 12 November 1662, Hooke was nominated as the custodian of experiments in the RS. With this new job, he stopped being Boyle's assistant; but

they corresponded until Boyle's death. On 16 June 1663, Hooke described his pump in front of the RS.⁴⁸⁴

On 15 February 1665, Hooke and Boyle made an experiment with a vacuum pump in front of the RS. Boyle rejected Cartesian physics, much like Newton did later. Boyle tried to rarefy the content of his vacuum receiver so much as to leave only the smaller substances thinner than air. Unlike of Torricelli or Guericke, Boyle did not try to pump out his receiver to get a "perfect vacuum," but he rather studied the properties of diluted air.

Like Noël, Boyle also saw several species of "matters" in the air, which proved to be true a century later in the experiments of Scheel, Priestley, Cavendish and Lavoisier. However, Boyle misrepresented the gas mixture as inhomogeneous, contrary to the later Dalton's law.⁴⁸⁵

In January 1671, Hooke reported to the RS about his new gigantic vacuum pump connected to the pump. He could sit inside it, as Hooke wanted to investigate the effect of reduced pressure on the human body. Hooke was small and slightly humpy; so, he easily dragged himself into a bowl where the place would be too tight for other people. His hunchback was mocked many times, as Newton ridiculed him with a funny statement that he saw further when standing on the shoulders of the giants.

On 23. 2. 1671, Hooke reported to the RS that he sat for a quarter of an hour in an emptied container and did not feel any special problems. Members of the RS commissioned him to repeat experiments with animals and with a burning candle. He climbed into the container at a pressure of 0.9 bar, but did not feel any problems, except for the pain in his ears. On May 5, 1671, he exhausted the air with bellows and measured the pressure with the gauge. The candle was extinguished much earlier before he felt the inconvenience in his ears. His heart rate did not increase during the experiment.⁴⁸⁶

⁴⁸⁰ Nichols, 1999, 1, 5, 9, 22; Bogoljubov, 1984, 47, 52, 54, 229; Schaffer, 1993, 235.

⁴⁸¹ Shapin, Schaffer, 1993, 74, 159, 161, 227–228.

⁴⁸² Pouillet, 1853, 132.

⁴⁸³ Sparnaay, 1992, 26–27.

⁴⁸⁴ Shapin, Schaffer, 1993, 257–258; Nichols, 1999, 22, 26–27, 43–44.

⁴⁸⁵ Shapin, Schaffer, 1993, 262–263; Conant, 1958, 68–69

⁴⁸⁶ Nichols, 1999, 60.

Papin helped Boyle to assemble a third pump between 1675 and 1680. Hooke's method was improved by substituting the vacuum with "artificial air", CO₂, obtained by soaking coral in the acid. The pump with two cylinders reached 0.01 bar. Two hundred years later Wilde catalogued Boyle's book (1682) with a description of the pump in the library of Ljubljana Lyceum; today it is found in the NUK bind to six books of other authors.

5.5.2.3 Huygens' Vacuum in the Netherlands and in Paris

The vacuum pump and manometer capacity has undergone numerous improvements in valve, connector and trap in vacuum systems over the next centuries, which have enabled lower pressures. These tiny improvements, and mostly the precise cleaning of surfaces, proved to be important in the experiments of Christiaan Huygens, the second son of Descartes' friend the Dutch diplomat and poet Constantijn Huygens.

During the spring 1661, Huygens visited Boyle in London.⁴⁸⁷ After seeing Boyle's devices, he built his own pump in November in The Hague. He exceeded his role models because "the bladder remained empty all night," meaning about eight hours. Huygens' pump was better than Boyle and Hooke's use of a wooden piston.

In the same year in The Hague, Huygens observed anomalous suspension in experiments with "vacuum in vacuum" (Figure 5-44). He purified the cleaned glass tube with water, closed it, turned it around and connected it to the water tank. Due to the resulting vacuum, the water in the tube was higher than the level of the collector. He placed it all under the bell-shaped container connected to the pump. When the air was exhausted, he expected to align the water levels in the pipe and the reservoir. But often the water level in the tube did not drop until he shook slightly the device. Boyle, who was dealing with similar problems on the other side of the Channel, initially did not believe Huygens's assumptions; Boyle attributed the result of the experiment to impurities. He and Towneley could not repeat Huygens's experiments. After two years of precise cleaning of their device, Boyle and Hooke

finally got Huygens' results with water and mercury. In January 1665 Huygens announced his discovery to Kinner from Prague, who reported the news to Schott. Unfortunately, even the exact Germans and Bohemians did not know how to repeat Huygens' experiments. Huygens did not immediately publish his results, which could bring him a lot of inconvenience today. It was not until July 1672 that his experiment was described in a Parisian magazine of scholars. Two years later, Huygens' former assistant Papin reported on the success, attributing the anomalous suspension to the bubble of air in the liquid.⁴⁸⁸

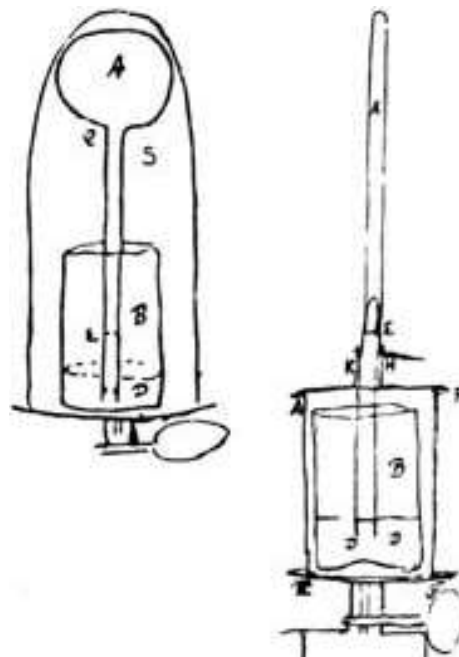

Figure 5-44: In 1660 and in 1673, Huygens' sketch of the experiment with a "vacuum in vacuum" helped to understand the need for precise cleaning of surfaces in vacuum technology

In the spring of 1672, Newton and Hooke quarreled about their theory of colors. Huygens' experiment certainly promised some less severe blood. The RS Secretary, Oldenburg, provided a translation of the Huygens discussion for the August issue of the Philosophical Transactions, since most members of the RS were unable to read the French notes fluently. During the holidays, the members of the RS met only informally, so Huygens' ideas were discussed by the RS only on October 30, 1672. The special interest was shown by Hooke, Wallis, and

⁴⁸⁷ Sparnaay, 1992, 25.

⁴⁸⁸ Frankfour, 1976, 158; Shapin, Schaffer, 1993, 244, 271, 273, 277.

president of the RS Brouncker. They published a notable paper about Wallis' letters mailed to Oldenburg.⁴⁸⁹

In July 1672 Newton and after him Huygens attributed the phenomenon to adhesion between two solids or between solid and liquid. While Huygens believed that adhesion was caused by particles of the ether, Newton and the Dutchman P. Musschenbroek attributed the cause to the attractive forces between molecules and not to the force of gravity. Wallis rejected Huygens' Cartesian fine matter; the result of the experiment was explained by the "lack of elasticity" of water or mercury.

On 6. 11. 1672 in front of the RS Hooke read the paper about Huygens' experiment, which was not published. Two weeks later, Hooke carried out additional experiments in which the water was 12 inches above the equilibrium plane before it began to fall. "Huygens effect" was explained by Huygens' Parisian confidant, the poet-critic Jean Chapelain (1595-1674), with the assumption of the pyramidically shaped atoms that supposedly take the leading role in water under exhausted air. Of course, Huygens refused that idea too. He himself saw in the phenomenon the pressure of a fine substance, like Hooke. Later, Laplace attempted to explain the experiment with capillarity. In the 19th century, the phenomena interested the Belgian Jean-Jacques-Daniel Dony (abbé Dony, 1759 Liège-1819 the Englishman Charles Frederick Partington (Wartington, † 1857), and after them the German Helmholtz. In the 20th century, the research was continued by Huygens' fellow Dutchmen Kamerlingh-Onnes, his student Willem Hendrik Keesom (1876 Texel-1956 Leiden) and Casimir at Philips Research Laboratories in 1948 (Figure 5-45).⁴⁹⁰ The electromagnetic causes of the Casimir effect have shown that Newton may have been amongst the closest to the truth.

In 1662, Huygens assembled another pump, which became a model for many later performances. Position of the components of the first pump were turned upside down on that occasion. By adding a mixture of oil and water to the piston, the surface between the piston and the roller was better protected against moisture, and

at the same time retained enough moisture for the leathered ring around the cylinder. While he descended the cylinder, the valve opened and let some liquid in. He bound his vacuum container and the pump in the metal plate. Since he did not find enough experienced glassblowers among the Dutch experts, Huygens used a pharmacy dish for a vacuum container.



Figure 5-45: Hendrik Brugt Gerard Casimir (*1909; † 2000)⁴⁹¹

Huygens settled down in Paris in 1663 to develop a new center for vacuum research. He presented the air pump to the Montmor's Parisian Group. In 1664, that group became the foundation of the Académie Royale des Sciences (AR) with Huygens as its leading member, though without the important associate Petit. Huygens stayed in Paris for two decades with interruptions due to his return to the Netherlands in June 1665 and the illnesses between 1670 and 1671 and between 1676 and 1678. In a later version of the pump presented in 1668 before the AR, Huygens replaced the metal plate with two inches thick wood connected to the iron plate that fixed the pump. He used bronze emptied receivers with wide apertures, which enabled a variety of experiments. The problem of sealings between the container and the base plate was solved with a lot of soft yellow mixture of wax and turpentine.

⁴⁸⁹ Wallis, *Phil.Trans.* 24. 2. 1672/3.

⁴⁹⁰ Sparnaay, 1992, 47–50.

⁴⁹¹ Casimir (anonymous notice), *Europhysics News*, July-August 2000, 30.

The same cement was used by Boyle, who remained in genuine relations with Huygens. Huygens confirmed the validity of Boyle's law and derived a barometric equation that heightened his interest in logarithms.⁴⁹² The same equation was used by Newton in his Principles.

The work of the first vacuum researchers was often dangerous. On 14. 4. 1668, during the fourth Huygens pumping of an octagonal vessel in front of the members of the AR, there was an explosion; the particles of the device were flying a meter far. Luckily no one was seriously injured, and more cautious academics later watched Huygens' experiments from an academic distance. In the next week, Huygens gathered somewhat scared members of the AR and showed them an experiment with a clock. Its ringing was almost no longer heard from the exhausted container in which the clock was immersed. As the first, Kircher proposed a similar experiment with the magnetic deviation of ringing bells in a vacuum. Guericke made that experiment which again proved excellent collaborations among the Catholics and Protestants of those times.

In 1673, Huygens published a plan for a pneumatic lift, where the blast explosion lowered the pressure in the vessel. The air pressure pushed the piston into the bowl and raised the weight. With his elevator, Papin raised four or even five people with the excited exclamations of AR members and of the mighty minister Jean-Baptiste Colbert himself. Unfortunately, the procedure was not repeatable.⁴⁹³

Ten years later, the Protestant Huygens returned to the Netherlands before the revocation of the Edict of Nantes could damage his faith in October 1685. His work was subsequently continued by one of his executives, de Volder, in collaboration with the workshop of Johannes Joosten van Musschenbroek, the father of later famous physicist Pieter Musschenbroek.

5.5.2.4 Papin's Pumps

Like Huygens, Papin was also a Protestant. The Huguenot Papin was born to the wealthy parents in Coudraies near Blois, 150 km southwest of Paris. In 1669 he finished the University of

Angers. Two years later, he went to Paris, where he learned mechanical skills at the Antoine Gaudron's (1640-1714) watchmakers manufacture. Papin collaborated with Huygens and became his assistant in 1672/73. Huygens's advice opened new horizons to him at meetings with Leibniz. Papin invented his handy three-way switch to become a member of the AR and RS.

Just like later Huygens had to abandon Paris when the Protestants lost their space in France a decade before the abolition of the Nantes Edict in 1685, Papin was also forced to find his new fatherland. Papin became Boyle's helper in London, in 1679 Hooke's assistant in managing the correspondence of the RS, and finally the custodian of the experiments in the RS. Between 1688 and 1695, he was a professor of mathematics at the University of Marburg in the service of Count Karl of Hessen. Unfortunately, the count wasted too much money for his war against the French to pay the Papin's inventions well enough. That is why Papin traveled through Italy and Germany for several years. Between 1692 and 1700 he argued with Leibniz about the measure of motion. For the proposals of the quarreling parties, they later coined the terms impetus, momentum or the quantity of motion ($m \cdot v$) and the "living force" of Papin's times, later referred to as the kinetic energy ($m \cdot v^2$). Papin was sorely defending his Cartesian position of the preservation of $m \cdot v$.

In 1707 Papin returned to England, but both his patrons, Boyle and Hooke, had already died. Therefore, he could not get a job at Newton's RS, where he cooked for King Charles II three decades earlier in an economic pressure cooker with Papin's design of steam-release safety valve. Finally, he was struggling for his piece of bread when he died in a significant shortage in London with almost nothing to boil in his pressure cooker.⁴⁹⁴

In May 1674 the Parisian academician Mariotte estimated Papin's pumps as twice cheaper, safer and more useful than Huygens' device. They were sold for four English Guineas, as we read in the report of Huygens' mechanics the Englishman Jean's son Louis Hubin (* 1628; † 1703) who

⁴⁹² Shapin, Schaffer, 1993, 267; Frankfourt, 1976, 101–102.

⁴⁹³ Sparnaay, 1992, 53–54, 30, 40; Frankfourt, 1976, 156.

⁴⁹⁴ Sittauer, 1989, 8–9; Bogoljubov, 1984, 209; Frankfourt, 1976, 155; Asimov, 1978, 144–145.

served as the enameller (*émailleur du roi*) to the French king in rue St Martin of Paris in 1687.⁴⁹⁵

On 14 December 1687, Papin presented his vacuum device for circulating water by diluting the air in front of the RS, immediately after the election of the new FRS, the Carniolan Valvasor. At that time, they read the first part of Valvasor's letter about the flow of water through the karst underground below the Lake Cerknica, which was based on the older theory of the Jesuit Kircher. First, Papin showed his vacuum experiments, then Newton's friend Halley illustrated the filling and emptying of the Cerknica lake according to Valvasor's description with the help of three connected containers placed at different heights. Valvasor certainly personally met important vacuum researchers when he traveled through Germany, France and England between 1658 and 1672. In 1667 he was in Paris, later in Toulon and in Lyon again in 1670. Thus, Carniolans were again somewhat nearer the pioneering research of the vacuum.

Except for Guericke, all pioneers of the vacuum exploration started their research very young: Torricelli was thirty-six years old, Pascal twenty-four, Carniolan Auersperg 39, Boyle 32 and Huygens 31. Their assistants, Viviani, Hooke, Papin and Hauksbee, of course, were even younger. The first barometer and air pressure experiments were carried out in the Catholic circles of Northern Italy and France, and the first vacuum pumps were developed by Protestants in Germany, England, in the Netherlands and France. For some reasons, the early pumping which enabled the changing of the experimental tools inside of vacuum receiver seemed to be the affair of Protestants, while the Catholics preferred the better vacuum of their early barometric tubes. The deniers of vacuum grew on both sides like the protestant Leibniz or the Catholic Jesuits and Descartes. Most of the young vacuum technology pioneers have traveled a lot at least during their studies, while Huygens and Papin have journeyed even as the established researchers. In this way, the details of the inventions spread relatively quickly through demonstration and personal contacts, especially in the scientific societies in Florence, London and Paris. These academies have played the role of modern vacuum societies, although they were, of course, intended for all branches of knowledge. For most early

researchers, the investigation of vacuum was only part of their wider research projects focused on the properties of liquids, especially in Pascal and Boyle's networks. Hooke and, above all, Huygens were experts for almost all physics. Despite the bloody religious wars of the time, religion was not an obstacle to the spread of discoveries. Thus, the Protestant Boyle learned about Guericke's experiments by reading the book of Jesuit Schott. More bitter disputes involved the British vacuum researchers due to political tension during the Restoration.

With his description of the vacuum, Boyle came across a fierce rival, his four decades older philosopher Hobbes. The dispute was politically colored; Boyle's elder brother, Broghill, was a member of the weak government of the Protectorate after Cromwell's death until May 1659 and an adversary of the Presbyterians. The monarchist Hobbes opposed the authority of both Catholic and Anglican churches; of course, he cordially greeted the Restoration in May 1660. He was F. Bacon's secretary and the friend of Harvey. In Parisian exile Hobbes taught mathematics to the King Charles II. In 1662, he devoted himself to "Physical Problems"; but later received the royal salary, though quite irregular. He rejected the idea of Boyle's RS about the basic role of experiments; he had such a position to defend the philosophical pursuits against "craft" work, even though Hobbes admired Galileo. The idea of a vacuum seemed overwhelming even in political terms. Although Hobbes' works were never printed in *Phil.Trans.* of the RS, his criticism strongly influenced experiments and even the changing of Boyle's vacuum pump performance. The Boyle's group of moderate puritans in the RS supported the parliament against the king in fear of absolute monarchy. Later, Boyle's group was politically successful, as RS had received the right to print, while in 1668 Hobbes was banned from publishing political and religious works in England and forced to issue them in Amsterdam. In 1674, due to political controversy, Boyle was particularly hostile to Hobbes' collected works which appeared in 1668. Hobbes had an attractive force at contact between smooth marble plates for the main evidence against Boyle's description of the vacuum. The phenomenon was explained only by Leibniz in February 1672, by Huygens at AR in June 1672, by Newton in a letter to Boyle

⁴⁹⁵ Shapin, Schaffer, 1993, 273.

on February 28, 1679,⁴⁹⁶ by Josef Stefan, and Casimir.

Vacuum pumps were the most expensive scientific tools of the time. According to preserved paintings, Boyle's pumps were about 0.5 m high, that is, much smaller than Guericke's giant, located on two floors of the house. Even the gigantic barometers with water or wine were not cheap. Much experience in blowing glass was needed to make such devices. Thus, Mersenne could not design the Torricellian experiment in Paris, where he had no capable craftsmen at hand. Pascal was more successful, as he was helped by the famous glassblowers from Rouen. From 1647 to 1670, a total of fifteen pumps were built in Magdeburg, Oxford, London, Paris and the Netherlands:⁴⁹⁷

- The first Guericke pump in Magdeburg in 1648. Two years later, he created a pump, in which he evacuated hemispheres for the famous Magdeburg experiment in Regensburg in 1654 and sold it to Schönborn.
- Grotto's improvements to Guericke's pump.
- One or more pumps at the Boyle's house in Oxford. The first of them was made at the beginning of 1659 in London and they transferred it to Oxford in March. In December 1661, a new pump was planned in Oxford.
- One or more air pumps were in the Gresham College in London after Boyle transferred them from Oxford in the summer of 1660. With it, Hooke experimented from 1661 to 1663, and the operator Mayow showed visitors the operation of pumps in the autumn in 1667.
- Pump in Halifax in 1661.
- Huygens took the pump to the Netherlands in the autumn of 1661.
- By March 1663, Huygens assembled and later operated a pump for the Montmor's group. The group with Pascal's friends Petit, Roberval (until 1658) and others operated between December 1657 and May 1664 in Paris.

⁴⁹⁶ Shapin, Schaffer, 1993, 93, 114, 134–139, 150, 189–203, 225, 280–281, 290–292.

⁴⁹⁷ Hellyer, 1998, 295.

- In the mid-1660s they had a pump in Cambridge.

- Huygens brought the pump, built in winter 1667/68, into the rooms of AR between March and May 1668.

- Another Hooke's pump with a mercury gauge made in 1667, which Boyle described two years later as "An experiment that tests the motion and sensitivity of Cartesian fine matter called ether."

- The third Boyle's pump was compiled by Papin.

- Senguerd constructed a pump with a single almost horizontal piston, which he mentioned in his "Philosophy of Nature" in 1681 and described it in detail in the second edition four years later. According to Guericke's example, he used an oblique position of cylinders and sealed with water. His toothed rails, the front wheel and the cross-spindle were summarized = by Hooke, two pistons on one rod designed after Papin, and the installation of the elements reported by Boyle.⁴⁹⁸ According to Senguerd's plans in Leyden, Johannes Joosten van Musschenbroek made a convenient pump. Johannes Joosten's son, Pieter van Musschenbroek, took over Senguerd's Chair of Physics at the University of Leiden and contributed to the sale of the pump throughout Europe. Musschenbroek's pumps from the beginning of the 18th century used to be among the oldest preserved⁴⁹⁹ since most of the elderly tools were destroyed by the teeth of time.

- Hauksbee's double-cylinder pump, manufactured according to Boyle and Huygens' plans of 1675, was on sale between 1703 and 1709. Individual products are still on display today.

5.5.2.5 Hauksbee's Vacuum Pumps with Ljubljana Franciscans

The vacuum pump caused first-class philosophical disputes between Aristotle's or Descartes's followers and their antagonists, the Galilean admirers of modern new science. The main propagandist announcer of novelties was Francis Bacon, who, like Janez Vajkard

⁴⁹⁸ Schneider, 1986, 399.

⁴⁹⁹ Hellyer, 1998, 295, 335.

Auersperg half of a century later, ended political work in disgrace in 1621 and devoted himself to science. Janez Vajkard Auersperg felt the resemblance of his own and Bacon's fate, and he therefore paid for the first German translation of Bacon's work. At the same time, he decorated the Ljubljana palace with a picture of the fall of Helios' son Phaeton, whose prided but incompetent drive of solar chariot Zeus punished with a deadly strike.

In the meantime, the vacuum pump in the hands of the draper's son Hauksbee the elder (* 1660) became part of the industrial offer after the initial Boyle's support. His nephew Francis Hauksbee (* 1687) already advertised his vacuum pumps as a member of a powerful Drapers' Company of the City of London. After Hooke's death, the experiments in the RS were being prepared by the self-taught Hauksbee the elder (* 1660). He used to be Boyle's assistant, but he was not employed by the RS as Hooke used to be. On 15 December 1703, at the first session of the RS, under the direction of new President Newton, Hauksbee described an improved double-barrelled air pump with two pistons, which was much easier to use. Boyle's pump enabled Hauksbee's observations of the speed of moving bodies in a vacuum. The next year, Hauksbee emptied the container with a volume of 0.7 l to a pressure of 0.0025 bar within two minutes.

The erudite of Ljubljana closely followed the western novelties. Guérinois' work, read by the Franciscans in Ljubljana, became more involved in Gassendi's atomism and experiments with the (Boyle's) pneumatic vacuum pump. Jacques-Casimir Guérinois (1640 Laval in western France-1703) was a Dominican monk who served as the professor of theology in the University of Bordeaux. His books in Ljubljana Franciscan library proved again that the monks might have some political quarrels among their orders, but they certainly loved to read useful valuable books of their alleged opponents without any real limits.

5.5.2.6 Getters

The term "getter" is derived from the English verb "to get". The getter reacts well with gases and thus removes them from space. The getters appeared very early, so pumping was soon no longer the only way to get a vacuum. As early as in 1674 and 1684, Boyle investigated the porosity

of the substance and the occlusion of gases. The phosphoric anhydride was used initially to remove traces of water vapor in a vacuum. In 1772 Fontana discovered the adsorption of gases in hot wood charcoal. He was a priest, a professor of logic and physics in Pisa, and then in Florence, where he was also a physicist at the court of the Archduke Leopold I. The insulation of his pumps prevented any contact with the outside air while the ember of burned charcoal was dying. With this, the adsorption effect of charcoal was saved for the air in the recipient. Landriani described Fontana's achievement in a letter mailed to the Englishman Priestley, who successfully repeated the experiments in 1775. The discovery was, in one way or another, used by Scheele (1773) and B. Higgins (1776).

The invention of Fontana was described by the Dutchman Ingenhousz upon his return from Vienna to England in 1782. Ingenhousz assembled a device with a cover made of copper and of brass, but unlike Fontana, he considered that it was not possible to get such a good vacuum with gettering alone as with pumping. The Croat Domin agreed with Ingenhousz and announced that the adsorption could be used elsewhere.⁵⁰⁰ The Frenchman Regnault of Collège de France improved the vacuum by replenishing the container with water vapor before pumping; then it was extracted with H₂SO₄, stored in a smaller container which Regnault finally broke within the emptied receiver. The procedure was repeated several times. A similar method with CO₂, oxygen and other gases was later developed by others. In 1852, Andrews followed Davy's = advice and twice filled his vacuum receiver with CO₂ and emptied it. After that, he fixed the rest of his gas with potassium carbonate.

Andrews' method was taken over by Gassiot who used potassium carbonate to remove enough gas from his Geissler's cathode ray tube to prevent discharge. The exploration of adsorption in charcoal was continued by Dewar and Tait in 1874. The vacuum was obtained only by adsorption, completely without pumping.⁵⁰¹ Dewar increased the adsorption power of charcoal with cooling in the liquid air. The

⁵⁰⁰ Domin, 1987, 182–187; Radić, 2020.

⁵⁰¹ Andrews, 1889, 224–227; Dewar, 1927, 1116, 121, 127, 892, 1014, 1118, 121, 127, 894, 1120, 1244.

obtained pressure was estimated at $3.8 \cdot 10^{-3}$ mbar (1/350 torr). Finkener filled the oxygen tank and exhausted it. By heating the copper to the red grill, he then bonded the remaining oxygen to the copper oxide and got a pressure of 0.033 mbar.⁵⁰²

5.5.2.7 Early Vacuum Experiments of Italian Jesuits

The getters and barometers were essentially the Florentine inventions. Galilean physics and vacuum experiments of Florentine academicians were much more slowly accepted at Jesuit schools than Bošković's physics a hundred years later. The Jesuits at least at first initially resisted the existence of a vacuum as a logically impossible and equal to zero. Vacuum experiments have been interpreted by the Jesuits of Linus' networks. The drawings in Jesuit manuscripts are the only relevant data on glass devices for vacuum experiments used at Italy and at the end of 17th and early 18th centuries. The vacuum pumps composed in London, Oxford, Paris and the Netherlands were different from school sketches of Italian professors, which show some specific features of Jesuit vacuum research (Table 5-2).

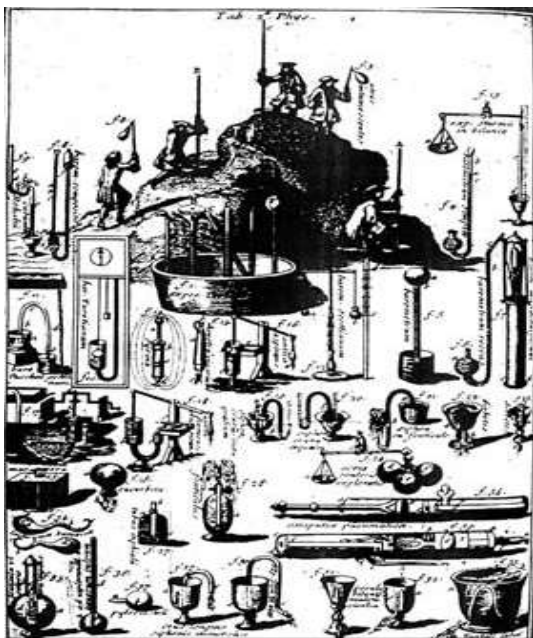

Figure 5-46: Measuring the height of the hill with the barometer.⁵⁰³

⁵⁰² Rosenberger, 1890, 684; Priestley, Autobiography 1966, 165, 181.

⁵⁰³ Esteran, about 1720, 311.

Other Jesuitical manuscripts contain less useful images. Panici and Guarini still believed in Linus' theory,⁵⁰⁴ but they did not reject the vacuum. In 1699/1700 Panici taught physics at the College of Rome; he described Boyle's experiments, but he was more interested in the explanation of the colleagues Linus and Faber (Fabri),⁵⁰⁵ whose textbook the Jesuits used in Ljubljana. Panici acknowledged the pressure of the air and commented Torricelli's famous letter to Cardinal Michelangelo Ricci. In addition to Boyle, Panici quoted Giovanni Alfonso Borelli and the Roman professor Jesuit Benedictis who taught in 1666. Panici was interested in the achievements of Bartoli from Ferrara, who served as rector of the Roman College between 1670 and 1674 and published the biography of Zucchi in 1682.

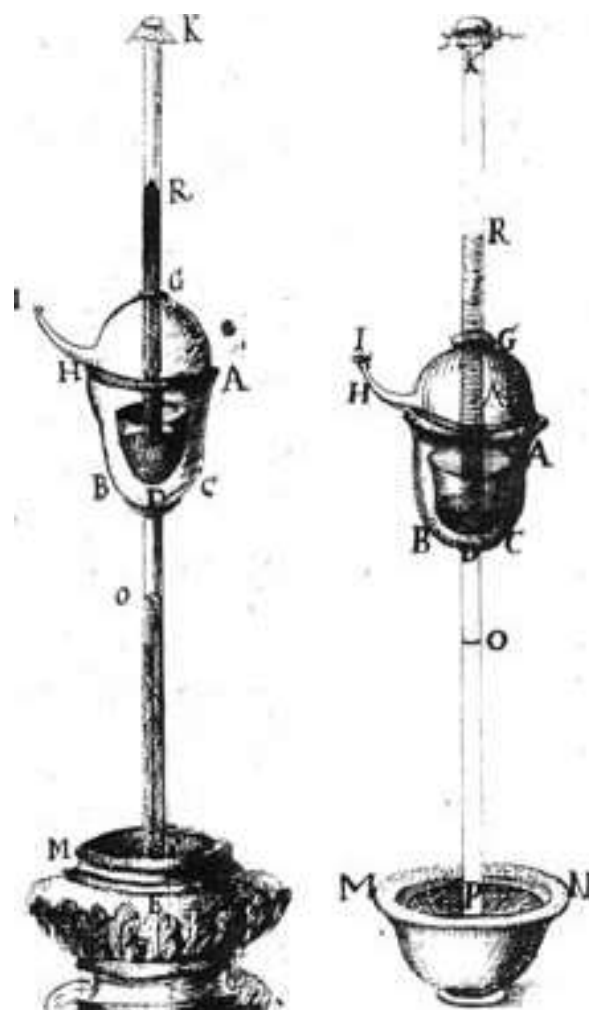

Figure 5-47: Vacuum in a vacuum⁵⁰⁶ by Guarini (1706, 341/342)

⁵⁰⁴ *Fistulae* (Guarini, 1706, 339).

⁵⁰⁵ Panici, 1700, 990–992, 996, paragraphs 1242–1245, 1251.

⁵⁰⁶ Guarini, 1706, 341/342.

Panici noted the measurements of the masses and densities of air of Galileo, Mersenne and Faber. He examined the experiments of Florentine scientists with mercury and Galileo's experiments with water in support of his opinion on the vacuum.⁵⁰⁷ Thus, his description of the vacuum was the basic part of the *Physics* of Panici. He devoted his last chapters to it.⁵⁰⁸

Guarini was a professor of physics at the College of Siena in 1703 and a professor of mathematics at the Roman College between 1710 and 1712. Six years after Panici, he criticized Descartes's theory of vortices, primarily because of Descartes's opposition against vacuum. He reported on Torricellian experiment, Magni and Linus. He described Boyle's pneumatic pump and vacuum experiments at the Florentine Academy⁵⁰⁹ and, above all, Roberval's theory of vacuum.



Figure 5-48: The Jesuit Barometer⁵¹⁰

⁵⁰⁷ Panici, 1700, 992, 994–995, paragraphs 1246, 1249–1250.

⁵⁰⁸ Panici, 1700, 980–998, paragraphs 1226–1254.

⁵⁰⁹ Guarini, 1706, 77, 295, 304–305, 309–314, 319.

⁵¹⁰ Guarini, 1706.

Panici and Guarini taught at the Collegio Romano. Their sketches show devices that were later explained to a young Roman student Bošković from Dubrovnik. Half a century after Panici and Guarini, Bošković's physics assumed a vacuum for one of its foundations. The question of Bošković's vacuum has now been raised in a completely differentiated way than in the earlier dispute between peripatetic and atomists.⁵¹¹ Bošković avoided the Cartesian linguistic problem of vacuum as nothing. Therefore, for most Jesuits the description of the vacuum in Bošković's networks was the only useful way out of the puzzle that was triggered by the already obvious success of vacuum experiments. The first measurements of heights with barometers were carried out in France on 19 September 1648 and five years later in England. Much less is known about altitude measurements in Italy and the Habsburg Monarchy. Esteran's drawing shows measurements in Italy or in Spain as he served at both places. From Esteran's picture, we can find out how at a certain height of the hill the researchers reported time and direction of winds at the era when they had no portable clocks available yet (Fig. 5-46).

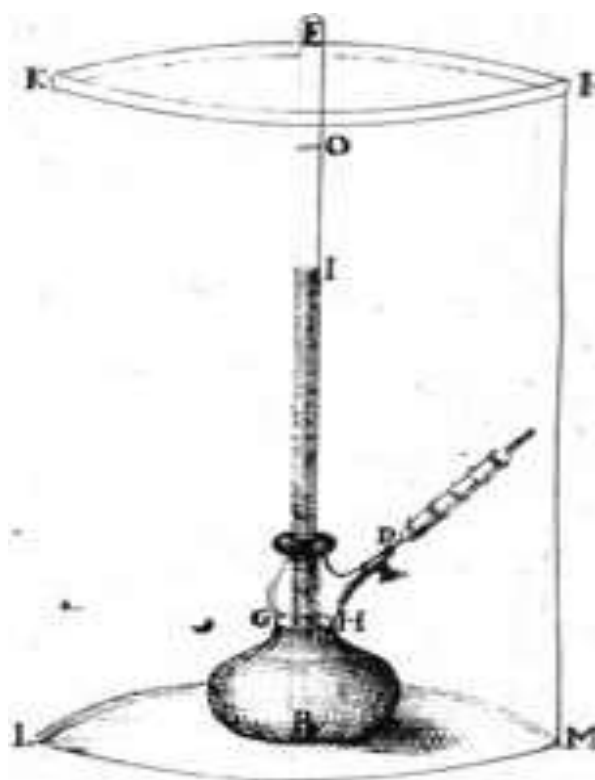

Figure 5-49: Simple Italian Jesuits' Pump⁵¹²

⁵¹¹ Hellyer, 1998, 389.

⁵¹² Guarini, 1706, 341/342 b.

Roberval and Auzout first observed their barometer in vacuum in 1648. Soon after, the experiment was repeated by Roberval's friend Pascal. A similar Boyle's experiment was the one which Schott appreciated the most among all Boyle's achievements.⁵¹³ The experiment was termed a "vacuum in a vacuum", and later it was particularly well-known in Huygens's version (Fig. 5-47).

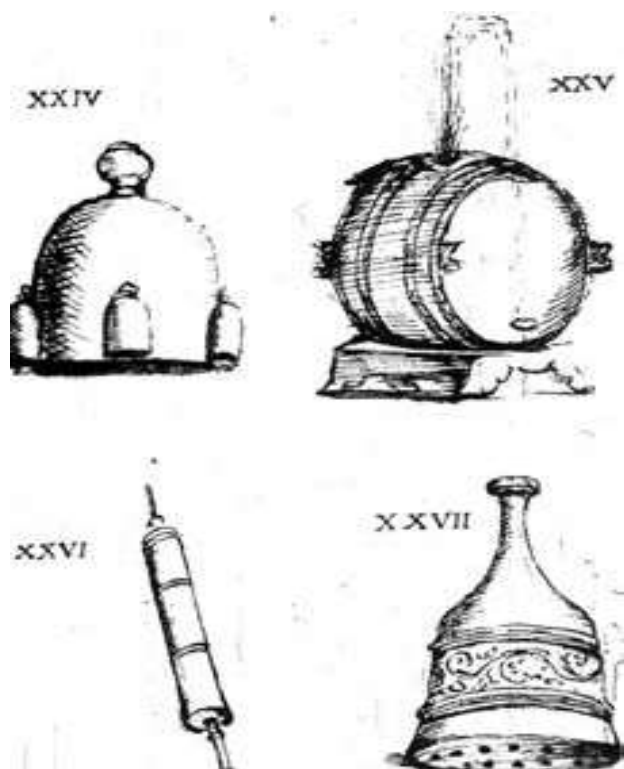

Figure 5-50: Other equally simple Italian Jesuit Pump⁵¹⁴

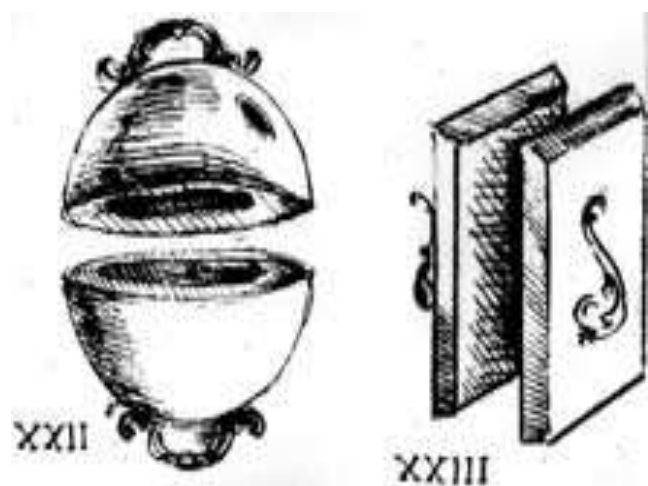

Figure 5-51: The Magdeburg hemispheres.⁵¹⁵

⁵¹³ Boyle, 1965, 1: 33–39, 168–169 (17th experiment and its defense against critiques); Hellyer, 1998, 288.

⁵¹⁴ Anonymous, about 1700, 181.

Guarini twice sketched the famous Roberval's experiment for his students.⁵¹⁶ A mercury column dropped when the barometer was placed in a vacuum container. When the air filled the container, the column rose to a level that balanced the outer air pressure (figure 5-48).

Both Guarini and his anonymous contemporary drew simple vacuum pumps like early Guericke's tools in their manuscripts. The details of designs cannot be distinguished in the sketches of Figures 5-49 and 5-50.

Experiments with Guericke's Magdeburg hemispheres were explained within the Jesuit curricula in the chapter on adhesion rather than in the chapter on vacuum. Therefore, the sketches were depicted in experiments with the adhesion of two marble plates (Figure 5-51).⁵¹⁷ Centuries later, J. Stefan proved that the adhesion of two marble plates does not involve forces between the invisibly small constituents which were proposed earlier.

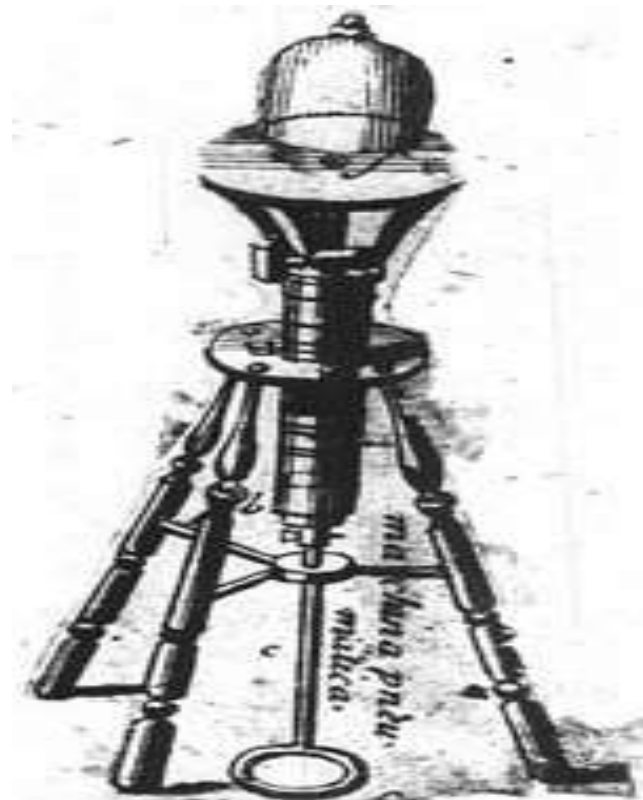

Figure 5-52: Italian Jesuits' Vacuum Pump⁵¹⁸

⁵¹⁵ Anonymous, about 1700, 181.

⁵¹⁶ Guarini, 1706, 333, 342; Middleton, 1964, 48–49, 54

⁵¹⁷ Esteran, about 1720, 406 left; Anonymous, about 1700, 181.

⁵¹⁸ Esteran, about 1720, 32.

Esteran's vacuum pump⁵¹⁹ was not quite the same as the pumps which Hooke had assembled for Robert Boyle in Oxford and London in the late 1650s and in the 1660s, nor even to those which Papin designed in the second half of the 1670s. Esteran's vacuum pump was even more distinct from older Guericke's pumps (Figure 5-52).

Esteran named his device as "pneumatic" by Boyle and also separately sketched each of its components. Like Boyle in 1669, Esteran drew and recorded dozens of experiments in an emptied receivers. In the vacuum, he observed the eventually changed activity of the balance, waterway fountain, suffocating of animals, ringing, adhesion, barometer, magnets and much more (Figure 5-53).⁵²⁰

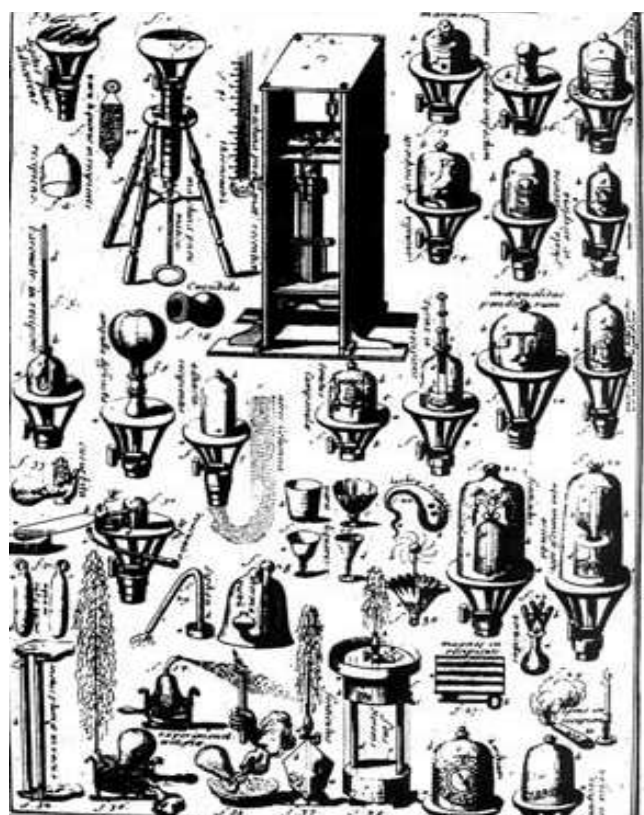

Figure 5-53: Jesuitical experiments in a vacuum⁵²¹

Panici's Pumps in the College of Rome closely resembled the first and second Boyle's devices. The first Panici' sketch differed primarily in the shape of the frame and with its different design of the shut-off valve under the vacuum container. There were some differences with the cover of

⁵¹⁹ Esteran, about 1720, 32 left.

⁵²⁰ Esteran, about 1720, illustrations 10, 21, 14, 8, 7, 5, 27.

⁵²¹ Esteran, about 1720, 320.

the container, which is not well visible on the Panici's sketch. The other Panici' sketch differs greatly from second Boyle's pump depending on the shape of the frame, the vacuum container and the movable parts (Figures 5-54, 5-55 and 5-56).

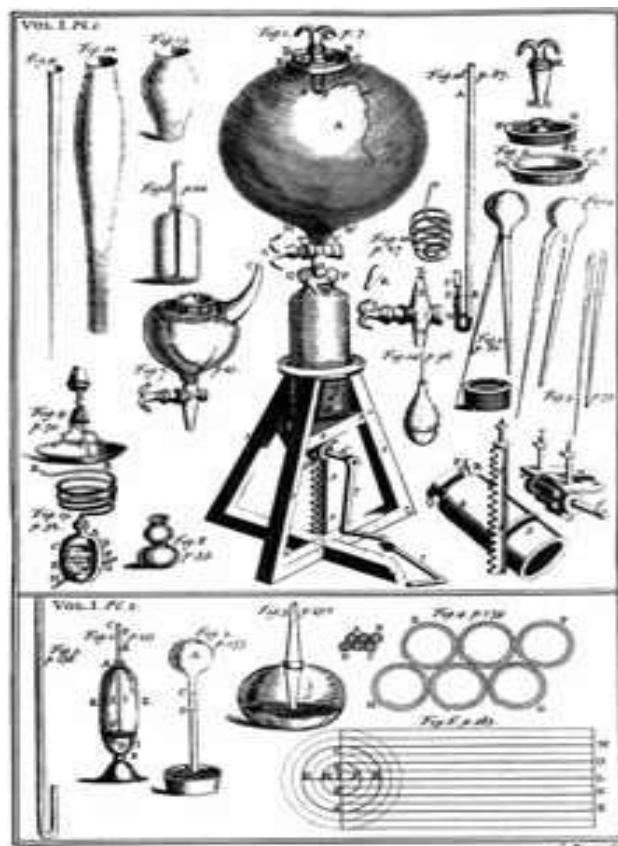

Figure 5-54: Boyle's pump⁵²²

Before our discovery which described the sketches of Jesuit professors in the Italian province, the researchers preferred their false opinion that Torricellian vacuum was mainly used in Italy under the influence of Galilean pupils from the Florentine Academy. Since the vacuum in the barometer was better than the vacuum of Boyle's pump, the Italians were supposedly not particularly interested in the pump, which would otherwise allow them to conveniently set up experiments with a much larger space for their execution. In Florence, Guericke or Boyle's pumps were not made, although the Tuscans knew their composition. The secretary of Florentine academy, Magalotti, was personally convinced of the advantage of Boyle's device in eliminating bubbles in a vacuum in England in 1678. The information spread mainly through personal contacts and books; so, the Florentine academics have argued

⁵²² Boyle (1660), 1965, 86/87.

that their own vacuum devices are as good or even better. The opinion was created as based on the early reports of pioneering Boyle's work, much like Boyle's underestimation of Guericke's pump.⁵²³ Apparently, at least in Rome, they tested Boyle's and similar pumps.

There are still many white spots left in the historical development of early vacuum devices. Since the devices from the 17th century have not been preserved, many details have been lost to oblivion. The manuscripts of the Italian Jesuit professors help us to fill the gaps in the knowledge of the experiments with which our ancestors proved the existence of a space with reduced pressure (Fig. 5-57).

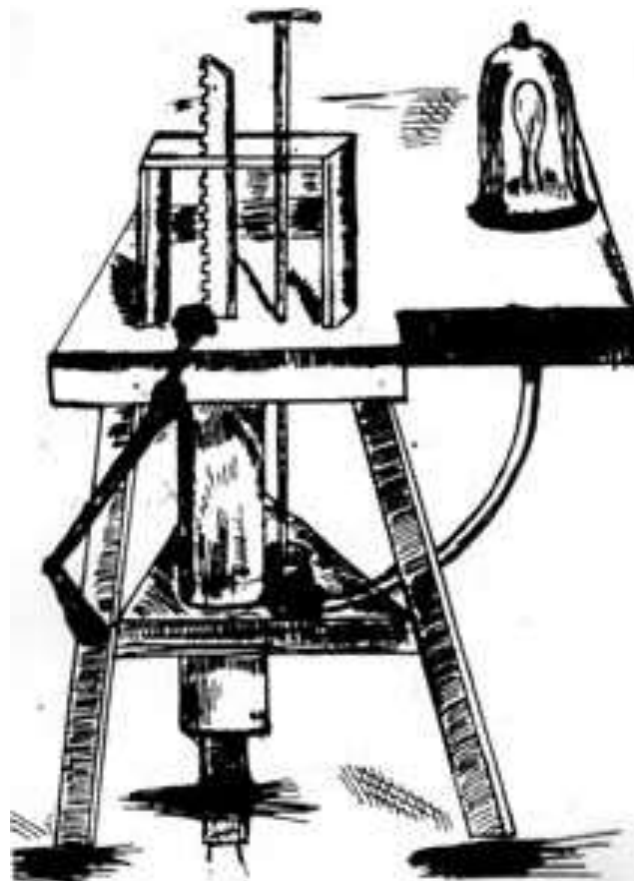

Figure 5-56: The other Panici's vacuum pump from around 1700⁵²⁵

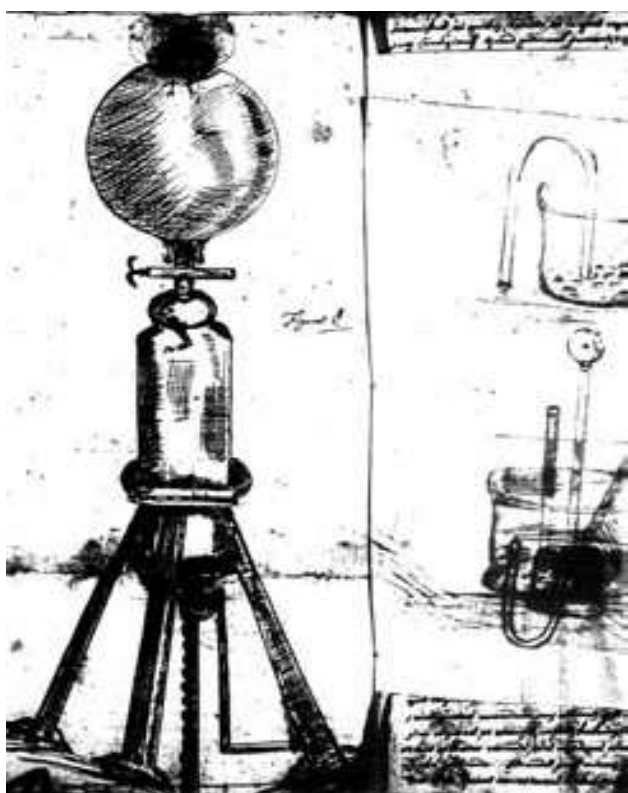

Figure 5-55: Panici's vacuum pump from around 1700⁵²⁴

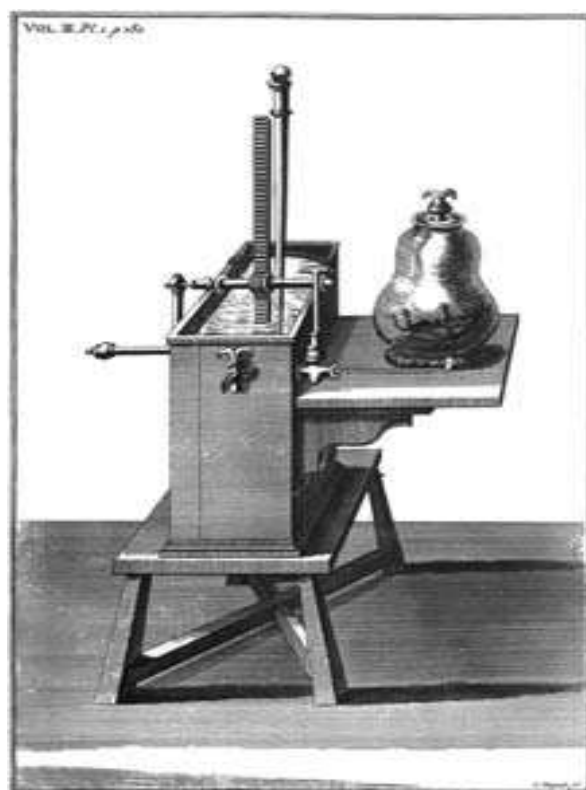

Figure 5-57: A somewhat inhuman experiment in Boyle's vacuum.

⁵²³ Schaffer, 1993, 62, 232–237, 264–268, 273–277.

⁵²⁴ Panici, 1700, 4.

⁵²⁵ Panici, 1700, 4.

Table 5-2: Vacuum experiments in Italian Jesuit manuscripts

APUG No.	Place, time and author	Contents of images
1093	Roman college 1700, Panici	two types of pumps, barometers, Roberval's experiment "vacuum in a vacuum"
1532	Around 1700, Anonymous	Magdeburg hemisphere, pump
Adiuncta 2	Roman college 1706, Guarini	experiment with vacuum in a vacuum
2144a	Around 1720, Manuel Esteran	Magdeburg hemispheres, pump, heights measurements

6 Books about Vacuums

6.1 Vacuum among Carniolans at End of the 17th and in 18th Centuries

6.1.1 Vacuum Books in Ljubljana at the End of the 17th century

The oldest data on the knowledge of vacuum in the former Carniola is illustrated by the relative prevalence of the books about emptiness. In May 1678, Mayr's catalog of books offered 2566 titles of different topics to Mayr's clients in Ljubljana. Mayr put up for sale the works of the then most important Jesuit researchers of vacuum: four Kircher's books, letters and two other Fabri's works,⁵²⁶ and six books of Würzburg professor of mathematics, the Jesuit Schott. Among the researchers of the vacuum outside the Jesuit order in Mayr's offer there were mainly three Boyle's books, among them the Tractate about Air with experiments in vacuum. In addition, Mayr offered the most important scientific journal, Phil. Trans. with Boyle and Newton's discussions published there (Fig. 6-1).⁵²⁷ This was the newsletter of the RS whose member became Carniolan Valvasor nine years after Mayr's printed offer.

Among the Schott's books in Mayr's offer, we miss a work "Hydraulic pneumatic mechanics", where in 1657 Schott first described the Guericke pump. For this reason, Mayr offered Technical Specifications from 1664, where Schott described in the first part the experiments with Boyle and Guericke's air pumps. The rich residents of Ljubljana were able to buy Schott's brand-new work on Magic, where in the 7th book on gas experiments Schott described the Jesuit exploration of the vacuum and the experiment with Magdeburg hemispheres (Figure 6-2).⁵²⁸ The richly illustrated book was, of course, purchased by the Jesuits of Ljubljana as it proved the reality of the Auersperg Prince's Regensburg stories.

⁵²⁶ Mayr, 1678, 53, 74.

⁵²⁷ Fabri, 1677; Mayr, 1678, 51–52, 53, 74, 84.

⁵²⁸ Schott, 1677 4: 518–533, 554–555.

Bohni Theatrum Anatomicum,	4
Pinax Theatri Botanici,	4
Institutiones Anatomicae,	2
Veumgartners Garten-Memorial/	2
Raschhaus de Lapide Hamatite & Etite,	2
Siegers Thier- & Kräuter- vnd Berg- Buch/	2
sambt der Salernitan. Schul/ fol.	
Physica subterranea libri duo,	2
Experimentum Chymicum novum,	2
Acta Laboratorij Chymici Monacen-	2
sis,	2
von der Deck Experimenta & Meditationes cir-	2
ca naturalium Rerum principia,	2
Guericks Schriften/ fol.	
Duteraut Wehmütige Nias, Thranen der	2
löblich höchst-bedrangten Arznei-	2
Kunst/	4
Wähnen von benehrtten Kopf-Arztneyen/	2
Bohls Epistola de Alkali & Acidi Insufficiencia	2
pro Principior. seu Elementar. cor-	2
por. naturalium munere gerendo,	2
Bohls Aurora Chymica,	2
Boerichij Dissertatio de Ortu & Progressu Che-	2
miz,	4
Lingua Pharmacoporum,	4
Hermetis Aegyptiorum & Chemicorum	4
Sapientia,	4
Docimastice metallica clarè & com-	4
pendiariò tradita,	4
Bohls Schuß-Wundt vnd Franckosen-Cur/	2
Boyle Tractatus de Aere,	12
Specimen de Origine & Virtutibus Gem-	2
marum, 12	G 2 Boyle

Figure 6-1: page 51 of the Mayr's bookkeeping offer to Ljubljana residents in 1678, which contained two Boyle's works. They were classified as "Libri medici", which, according to then relevant classifications, also included chemistry

Bohls Lexicon Græco-Latinum,	fol.
Schottij Scleron Geographicum,	fol.
Schottij Panegyricus memoriz Viri Generosi,	4
filii a Draxdorf,	4
Schottij Carolus Magnus explicatus & vindicatus,	4
Schottij de Re vehiculari Veterum,	4
Lapponia, i. e. Regionis Lapponum & gentis Descriptio,	4
Schottij de Stylo Exercitiorum ejus, & de Gymnasio styli seu varia scribendi Exercitio,	2
Regum Principumque Institutio, fol. de Archiepiscopis & Sacerdotibus cæteris Ecclesie Upsalienfis brevis Chronicon,	2
Schottij Astroscopium,	2
& Berneggeri Epistola,	12
Schola Curiositatis, sive Antidotum Melancholiz joco-serium,	12
Schottij Terentius Christianus, seu Comœdia sacra,	2
Schottij Apparatus Eloquentiz,	2
Prouptuarium Germanico-Latinum,	2
Schottij de Serpenticino,	2
Schottij Magia universalis Naturæ & Artis,	4
Organum Mathematicum,	4
Arithmetica Practica,	2
Schola Steganographica,	4
Technica Carniola,	4
Itinerarium Italiae,	12
Philosoph,	M
Schultheßij	

Figure 6-2: Mayr's bookkeeping offer to the Ljubljana residents from 1678, that included six Schott works which reported about Guericke's and other experiments on the bottom.⁵²⁹

⁵²⁹ Mayr, 1678, 89.

Table 6-1: Books on the vacuum in Ljubljana between 1678 and 1800

Author	Title	Place and Year of publication	Library
Mayeri (Georg Meier (1632 Lüneburg 50 km southeast Hamburg-1691/1695 Lüneburg, professor in Wittenberg)	Pneumatica (<i>Disputatio Pnevumatica De Attributis Dei In Genere</i> , University of Wittenberg Dissertation, 1662, second edition: <i>Pneumatica qua Scientia Spirituum Dei, Angeli & Animae hominis separatae Naturalis</i> , Wittenberg, 1666)	Wittenberg 1662, second edition: Wittenberg, 1666	Mayr's catalogue 1678 on page 84, also offering Georg Meier's Succincta Gnostologiae Delineatio Generalia Totius Philosophiae Fundamenta Methodice Exhibens Cujus Disputationem, University of Wittenberg Dissertation, 1660
Wolfgang Augustin Mayer & Marx (Markus) Eysenkrämer von Bissigheim	Lust-, Luft- und Feuer Kunst (Fancy air and fire art from which without cost and effort to gain how to make large and small rockets, pumps (pp. 12-13, 30, fig. 23-29) and great sticks, large and small, even preparing rockets throwing water balls with different curves and turns) bind to <i>Kurtzer jedoch gründlicher Unterricht, Wessen sich ein jeder Constabel od. Buchsenmeister in Feldzügen u. Guarnisonen befeissen, was er für Instrumenten und Bereitschaften, so zu den Canonis Sachen gehörig, bey handen haben zum viertenmal in Truck gegeben durch M. E. von Bissigheim, fürstlicher Württembergische bestellten Ingenieur</i> (Ulm, 1634, 1677, 1680)	Ulm: Schultes 1680	Wilde (reference code 1540), NUK (signature 5463) from Stična Cistercian library
Blaise Pascal	Traite de l'equilibre des liqueurs	1663, 2: 1698	Erberg 1798
Laurentio Gobart	Tractatus philosophicus de barometro	Vienna 1716, Graz 1746	Erberg 1798. Other Gobart's books were catalogued by Wilde (reference code 1494) and NUK (reference code 8294)
Robert Boyle	Experimentum Novorum	Geneva 1682	Wilde (1420), NUK (8340-8346)
Descartes	Opuscula posthuma physica et mathematica	Amsterdam 1704	Wilde (1421), NUK (6890)
Josef Anton Haymon	Disertatio Physico-Medica de Aire	Vienna 1758	1758 Erberg 1798, Wilde (1432), NUK (8184)
P. van Musschenbroek	Essai de Physique with the description of new varieties of machines pneumatics, and the experiences	Leyden 1739	Wilde (1442), NUK (8463)
Ferenc Kéry (Kéri, Keri, Franc Borgia, 1702 Kenézlő in northeastern Hungary-1768 Trnava)	Dissertatio Physica de corpore generatim, de que opposito eidem vacuo (promotion of the part of original work of his fellow Jesuit Luis de Lossada Prada (1681 Quiroga-1748 Salamanca)	Trnava 1753	1753 Wilde (1483), NUK (8257)
Franciscus Xavier Spindler (1726 Graz-1775 Graz)	Supplicium Mercurii in Barometro. Carmen (execution of mercury in the barometer, a song published in octavo format)	Graz 1752	Wilde (1568), NUK (8576)

Between 1655 and 1663, Schönleben, the son of a Ljubljana mayor, cataloged the books of the prince's elder brother, the Auersperg Count Wolf Engelbert. He had the first edition of Kircher's Great Art (*Ars Magna*), whose second edition Mayr offered to the citizens of Ljubljana a few months after the death of Prince Janez Vajkard. In 1697, Auersperg gave his copy of the Great Art (*Ars Magna*) to the Jesuits of Ljubljana, who were

just preparing for the opening of Ljubljana's higher studies. In that book Kircher examined Torricelli's experiment with a mercury barometer.⁵³⁰ Already for two centuries, mercury was dug in the Idrija mine; so, the experiments with it were especially important for Carniolans. We do not know how many books the residents of Ljubljana bought at

⁵³⁰ Kircher, 1664, 26–29; Mayr, 1678, 79.

Mayr's shop, since we know the catalogs of most larger libraries in Carniola only for the 18th century while only Valvasor's listing and the legacy inventories are relevant for earlier data of late 17th century. Certainly, the offered books on vacuum show that Carniolan ancestors were interested in vacuum puzzles very early. Boyle's works sold in Ljubljana still apply today as a key to the foundations of modern physics, chemistry and vacuum techniques; Ljubljana was not the provincial city three centuries ago without contact with the progress of vacuum research in the European centers of the time. Most of the books were purchased by the son of the first Auersperg prince and the son of his knighted tax collector, Franc Jakob Erberg, elder brother of Janez Danijel Erberg (Table 6-1).

6.1.2 *The Vacuum Related Instruction at the Jesuit College in Ljubljana (1706 -1773)*

6.1.2.1 Students Start Learning about the Vacuum

The younger sister of Janez Danijel Erberg, Maria, was married to the nobleman Matija II Jenčič. Shortly after the marriage, in 1674, Matija became the manager of the Auersperg's castle Poljane by Kolpa river. His son, the physicist Sigmund Jenčič, taught at the college in Ljubljana between 1701 and 1705 and again between 1713 and 1718. He must have remembered his uncle's stories about Auersperg's and Guericke's experiments. Therefore, in the thirty-five exams queries, his physics students of physics in Ljubljana learned the differences in the density of substances that enabled the operation of vacuum pumps.

In the Jesuit College in Ljubljana, they began to teach physics in 1706. Anton baron Erberg from Dol by Ljubljana, the first cousin of Sigmund Jenčič and son of Janez Danijel Erberg, was the first domestic author of the textbook about physics in Carniola. Anton was a professor in Ljubljana and during the last two years before the death even the rector of the Ljubljana College. He wrote *General and Special Physics in Aristotelian Chapters*⁵³¹ modified for the Maria Therese's

Reforms, which were printed only posthumously after Anton Erberg passed away.

In the first part of the conversation *On Creation and Decay*, Anton Erberg cited his own and the scorned Magni's works. In the second part, he addressed the physical changes of substance. He listed the vacuum experiments of Torricelli, Huygens, Boyle and Guericke. He heard a great deal about Guericke's and Auersperg's experiments in Regensburg from his father, and he did not completely shake off Aristotle's and Auersperg's doubts about the possibility of moving any stone through a complete vacuum. He has denied the possibilities for the existence of a vacuum and, in contrast to Magni, ensured that in the body there cannot be a completely empty space.⁵³² The opinion was still quite widespread in the time of A. Erberg's youth, but upon the publication of his book it had already become obsolete after the vacuum in steam engines became the leading industrial motor.

6.1.2.2 Erberg's Concept of Vacuum, his Collection of Textbooks and Experimental Tools

Anton Erberg's nephew Hallerstein together with his colleagues presented for the first-time their vacuum experiments to the Chinese Emperor in 1773. At that time, the great grandson of Prince Janez Vajkard Auersperg's brother, Herbert Auersperg, became the professor of special and general physics in Ljubljana in 1770. Anton Erberg's first cousin, B. F. Erberg, published the translation of *Physics of magnets* of the famous Dutch physicist P. van Musschenbroek in Ljubljana in 1754. In the same year, at least three Musschenbroek books were purchased at the college in Ljubljana, among them *Essay on Physics*, where he dedicated an entire chapter to an empty space. In contrast to Cartesians, Musschenbroek argued that empty space is much more than a space without a substance. He thought that the water was cooling faster in an empty space than in the air, which was incorrectly proved by stopping of the burning in an empty space. The mistake was due to the ignorance of the role of oxygen in combustion, which was investigated only by Priestley, Scheele and, above all, by

⁵³¹ Hellyer, 1998, 374.

⁵³² Erberg, 1750. 2: 351–353; Erberg, 1751, 2: 47, 351–353, 3: 151, 161, 492–497.

Lavoisier. All of them succeeded after A. Erberg's death.

Pieter van Musschenbroek was born in Leyden in the Protestant Flemish family which retreated to the north to avoid religious exoduses. By 1715 he studied philosophy, mathematics and medicine at the University of Leiden in the Netherlands. His best teacher was Boerhaave, a professor of medicine, botany and chemistry at Leyden since 1708. Pieter van Musschenbroek then went to visit Newton in London. He continued his studies in Germany, where he received his doctorate in philosophy in 1719 and became a professor of philosophy and mathematics at the University of Duisburg. He was experimenting in his classes. Between 1723 and 1739, he taught at the University of Utrecht and in 1734 he issued a famous textbook of physics in the Latin language, which was published two years later as the first physical work in the Dutch language. In 1732 he received the Astronomy Chair in Utrecht, and in January 1740 he accepted the Leiden Chair of Philosophy.

The vacuum pump was an integral part of every better laboratory in the century after its invention, like the later Leyden jar.⁵³³ We know very little about vacuum pumps at the Jesuit College in Zagreb.⁵³⁴ According to the catalog of manufactured scientific devices published by Johann Gabriel Doppelmayr's student Brander from Augsburg in 1753, the cheapest vacuum pump was worth 150 to 175 florins, together with the associated glass parts. The other pump costed 250 fl, and the costliest was sold for 350 fl. The most expensive pump was made according to the plan of 'sGravesande, the coworker of P. van Musschenbroek in Leyden. The microscopes were much cheaper, as only 30 to 40 florins⁵³⁵ had to be paid for them. On 17 September 1755, B.F. Erberg as the professor of mathematics enumerated the fifty-five instruments needed for the teaching of mathematics and physics in Ljubljana. They averaged the prices of 50 florins, but later the

⁵³³ Leyden jar was an earliest usable electric condenser. It got its name by the Dutch university where P. van Musschenbroek taught as one of the inventors. After his first experiments he got such strong electrical shock that he refused to repeat it by any chance.

⁵³⁴ Dadić, 1982, 2: 240.

⁵³⁵ Hellyer, 1998, 309.

Jesuits received yearly as much of half of that price for their maintenance. So, the people of Ljubljana could not afford to have more vacuum pumps which were at last three times more expensive than the average tools.

B. F. Erberg was a professor of mathematics, philosophy and physics at higher studies in Ljubljana between 1751 and 1758. From his student years he preserved the undated manuscript of Physics, in which he dealt with air and with the fear of vacuum. He devoted ten chapters to the explorations of vacuum, overpressure and air resistance. Among his favourite experimental devices was a pneumatic pump with its own vessel and a double piston needed to exhaust the air from the container. With a similar device, Boyle has already proven that the vacuum does not translate the sound. In his Ljubljana experiments with the pump, Erberg also glowed his metallic plate and demonstrated the transfer of thermal radiation through a vacuum. The pump had a special lamp. A resinous mixture of lead and silver was used to seal the emptied receivers. Thus, six Erberg's devices in his Ljubljana lab formed a vacuum experimental kit (Figure 6-3). Guericke's Magdeburg hemispheres were used to display the air pressure.

Thus, the grandson of the prince's customs officer, B.F. Erberg, acquired a Magdeburg hemisphere of Auersperg and Guericke for teaching at the Jesuit's college of Ljubljana a century after the original experiments in Regensburg. At least then, if not during the time of the first Auersperg prince, they could repeat Guericke's experiment four hundred miles south-east of Regensburg, in white Ljubljana. The Magdeburg hemispheres were enumerated again in 1811 among the instruments for the study of hydrostatics and in 1847 among the instruments for the exploration of gases. The device from 1755 was replaced by a new one made by the Ljubljana bell-foundry of Samassa. In the following years they wrote off the Samassa's Magdeburg hemispheres, which were not listed in the census in 1866. The third Guericke's hemispheres in a more modern version were acquired for the Grammar School in Ljubljana in the school year 1867/68. After 1755 in the college of Ljubljana the Jesuits used Heron's bronze fountain to demonstrate the lifting of a stream of water with compressed air, which was already known in ancient Alexandria. Erberg also obtained

a barometer for meteorological observations and a Cartesian diver, attached to a semi-transparent hollow ball, which, under pressure on the tube stop, descended from the surface to the bottom of the liquid. Erberg also purchased Heron's copper sprinkler. Like Magdeburg's hemispheres, both Heron instruments were written off before 1866. However, in Heron's case, they did not acquire new devices that apparently no longer fit modern curricula. Erberg's "Barometer for Meteorological Observations" was used in 1811, when Kersnik listed the teaching aids at the Central Schools in Ljubljana.

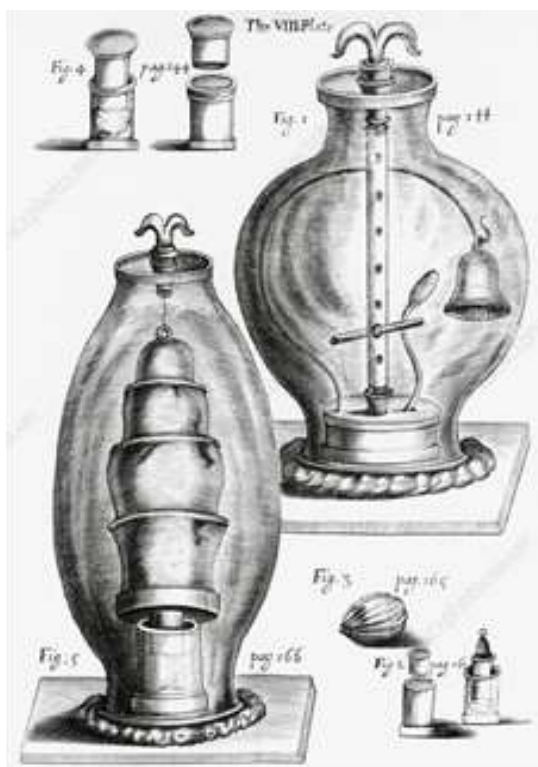

Figure 6-3: Woodcut from Boyle's book with an experiment of ringing in a vacuum, as it was shown to the students in the Jesuit College in Ljubljana after 1755.⁵³⁶

6.1.2.3 Taufferer's Edition of Mairan's Book

The Rijeka (Fiume) native Tricarico taught physics in Ljubljana in 1757. Two years earlier, he printed his thirty examination theses in Graz, among which he laid the theses in physics after his eleven theses from metaphysics. After describing the difference between physics and chemistry, students had to prove the existence of a vacuum and its distributions in the world. After his theses, he printed the popular physics conversations of the

⁵³⁶ Conant, 1958, 75.

French Jesuit Cartesian Regnault. He described Torricelli's experiments with a mercury barometer, the rejection of the fear of emptiness in books of Galileo and Kircher, and the experiments of Pascal, Mariotte, Boyle and Guericke with a vacuum.⁵³⁷

In 1760, the professor of physics Taufferer from Turn by Višnja Gora printed nineteen exam theses from the general and the same number of theses from special physics. He finished the examination with two theses about biology. The theses were defended by Škofja Loka natives Anton Feichtinger and Alojzij Vermati de Vermesfeld, where for the first time in the history of Ljubljana schools they publicly supported the Copernican system. Taufferer explained Torricelli's experiments with barometric tubes, an elastic ether and an empty space in the body pores. The small body particles are supposed to generate heat and sound with oscillation, and there should be an empty space around them. Dilution of the body is due to the spread of the pores (cavities) caused by the ingress of countless particles of fire. Similarly, thickening should be caused by the cavity shrinkage due to cohesion. Due to disorders in the ether balance evaporation of very fine particles from the cavities of the substance is expected. His ideas of a vacuum were noted in the first two chapters of his publications of translation of the book of the secretary of the Parisian Academy Mairan. Taufferer published it in a promoting print bind to his Ljubljana exams theses. Jean Jacques D'Ortous de Mairan (Dortoux, D'Ortous, 1678-1771) described a vacuum in a tube above a mercury column. He dealt mainly with meteorology; only on the first page he described the operation of the vacuum in the barometer and the air pressure.

6.1.2.4 Schöttl's Concept of Vacuum According to Raigersfeld's Records from 1763

Raigersfeld was the Carniolan noble family of the farmers' genus from Rakovica under St. Jošt mountain in Upper Carniola (Gorenjska). From 1761 to 1767 M. Raigersfeld studied law and cameralism at Sonnenfels' class in Vienna. Sonnenfels proclaimed M. Raigersfeld as his most talented student. In 1763 he studied at the elite Theresian Jesuit College in Vienna. There he

⁵³⁷ Regnault, 1755, 67, 349–357.

listened to the lectures of physics of former Ljubljana professor J. Schöttl, who used the textbook of Hungarian Jesuit Paul Mako.

Raigersfeld wrote about the vacuum and pores in the bodies.⁵³⁸ He first attempted to justify the existence of a vacuum, but only in subsequent chapters he began his mathematical equations. Regarding the vacuum, the Cartesians and Leibniz were opposed to the advocates of Newton and Epicurus. However, in the completely totally filled space, movement is not possible, as there is no space to move in. The vacuum must be between the stars. Raigersfeld and his teachers saw contradictions in the Cartesian doctrine of a subtle ether. He thought it would hinder the movement of the planets. This argument was repeatedly used in the second half of the 19th century. Raigersfeld had pores for a space between two distinguished particles of matter. In the pores there is an infinitely more vacuum than in the bodies themselves. There is also much more vacuum than matter in the pores, and Raigersfeld expressed the ratio between them with numbers. The weight is proportional to the amount of matter; in lighter bodies there is more vacuum. In the background of such thinking he anticipated the later William Prout's assumption of the same atoms with different mutual distance in different substances announced in 1815/16 after the experiments in a vacuum apparatus of Prout's own design.

Raigersfeld's pores in the bodies allow the propagation of sound and light. The particles moving through the substance experience a repulsive force. At other distances between particles, there is a mutual attractive force⁵³⁹ according to Bošković's theory. Raigersfeld did not mention the new Bošković's work by name because he did not provide much quotations anyway. His professor J. Schöttl and Mako, were among the most enthusiastic defenders of Bošković in the Habsburgian monarchy.

6.1.2.5 The Influence of Bošković's Physics in Ljubljana until 1773

In the 1750s, the Jesuits modernized physics classes at the College of Ljubljana. After 1753, they acquired many books about physics published by non-Jesuitical authors and modernized the

cabinet of physics. On March 9, 1758, the famous Jesuit physicist Bošković visited Ljubljana. On his way from Vienna to Venice, he slept overnight after a fine reception at the Jesuit College in Ljubljana (Figure 6-4). Bošković visited Ljubljana at last three times. At that era, physics course in Ljubljana was still a part of the course of philosophy together with metaphysics and logic. Only after 1764 the professors of physics in Ljubljana were no longer alternating every year, but rather they lectured physics for several years in a row. Their physics was also split in its modernized experimental (particular) and theoretical (general) parts.



Figure 6-4: Note in the Jesuit Diarium of the Minister of Ljubljana college on the visit of Ruder Bošković to the College of Ljubljana on March 9, 1758⁵⁴⁰

In the last decade before the suppression of the Jesuit order, all professors of physics in Ljubljana have been also the advocates of Bošković's physics. According to Bošković, the vacuum was purely imaginary, but not entirely nothing, because it changed completely real distances between masses. The penultimate rector of the Ljubljana College between 1763 and 1766, and again from 1769 to 1772, Dillherr, published Gobart's book about the barometer as a promoter in Graz in 1746. The small format booklet consisted of 220 numbered paragraphs. The fourth among them denied the "horror vacui", and the tenth correctly described the lifting of mercury in the barometer

⁵³⁸ Raigersfeld, 1763, 4–13.

⁵³⁹ Raigersfeld, 1763, 5–13.

⁵⁴⁰ SI_AS 1073, Manuscripts, I/40 r, page 1742 right.

due to the weight of the air. The descriptions of the experiments of Kircher, Boyle and other researchers followed. In paragraph 104, the possibility of dilution and compression of air with a pump was described.

The Carinthia native Janez Krstnik Pogrietschnig was a professor of physics in Ljubljana between 1764 and 1768. In 1768, he published the theses for the physics examination. His students bound their exam thesis together with the books of the famous authors to promote Asclepi's astronomical discussion and Bošković's physics. The balance of mercury in the barometer was explained without mentioning the vacuum, and the barometer was mainly analyzed from the meteorological point of view. In addition to Pogrietschnig's examinations, in Graz Bošković and Asclepi's works were also reprinted by the Viennese Biwald, the most important writer of textbooks of physics in the then Habsburg monarchy. He taught at the Jesuit College in Ljubljana between 23 October 1755 and 1757 and might have been there again as the student of last year of theology and assistant librarian in Graz, in 1761. His theses for physics examinations were repeatedly reprinted with minor changes. They contained no specific questions about the theory of vacuum, while Biwald's students had to know experiments with pumps, a siphon, and various artificial springs to describe the operation of the barometer. The opaque nature of the bodies was explained by the heterogeneous structure of parts of the body and by the evenly distributed mass particles and empty spaces in the body.

6.1.2.6 Vacuum-related Instruction on Lyceum in Ljubljana from 1773 until its Temporary Closure (Abolition) on 20th October 1785

In 1775, Jurij Vega passed the final exam at Lyceum in Ljubljana after he answered thirty-eight physics theses of his professor Gregor Schöttl, a relative of Janez Schöttl. In 1769 Gregor started to teach physics in Ljubljana.⁵⁴¹

In 1771, G. Schöttl considered the fluids in general, and he especially focused water and vapor, but he did not mention a steam engine nor a vacuum. In 1775, Vega and other students provided a description of matter, which, in addition

to the substance, also forms pores with a vacuum included. The students described the spread of light through a vacuum, referring to demonstration experiments with two decades previously acquired devices that they observed during their lessons (Figure 6-5).



Vega
1788

Figure 6-5: Jurij Vega (* 1754; † 1802)

Later Vega used the knowledge gained during his studies in Ljubljana. In 1800, the whole chapter of his textbook was dedicated to air pumps and presses consisting of piston, communicating vessels, recipients, and pipes. He specifically described Torricelli and Guericke's experiments with hemispheres. He knew that Guericke pump couldn't possibly achieve such rarefied air comparable to the vacuum in Torricelli's barometer. He described a dozen vacuum experiments using air pumps:

- 1) The height of the mercury column increased with pumping out the air above it.
- 2) He rarefied the air in the tube so that mercury went into an open pipe connected to a mercury container. When he released atmospheric air into a tube, mercury dropped down into the container.
- 3) As the air was pumped, the external pressure on the glass container's wall rose. In the case

⁵⁴¹ Schöttl, 1775, 33–52.

of large dilution, the deformation of the container may have occurred.

- 4) By allowing the atmospheric air into the emptied container, he levelled the external and internal pressure.
- 5) He described the Guericke's experiment in which 15 horses on each side, without any success, pulled the evacuated hemispheres.
- 6) The candle extinguished, and the poor animal choked in diluted air.
- 7) By diluting the air, he reduced the volume of the sound of the bell in the vacuum so that the ringing of bell was almost completely dried off.
- 8) He described the Cartesian diver which he had already used during the physics lesson in Ljubljana.
- 9) Despite the strong dilution of the air, the water in the recipients is only slightly heated during pumping.
- 10) Beer, milk and yeast secreted a lot of air bubbles in diluted air.
- 11) Some water evaporated when he considerably diluted the air above it. A completely transparent vapor was liquefied on the walls when he let the air into the container.

By weighing the emptied hollow sphere, he proved that the air had gravity. The bodies were heavier in a vacuum without buoyant force, which would counteract force of the gravity.⁵⁴²

After the suppression of the Jesuit order, physics at Lyceum in Ljubljana was taught by the former Jesuit Ambschell from Győr in Hungary for half a dozen years in 1778-1785. He was an enthusiastic advocate of Bošković's physics. He examined the barometer and empty spaces to make it the subject in his examinations. As the Ljubljana Rector, he was unable to prevent the temporary abolition of the Lyceum which remained closed for several months due to the Josephine centralization reforms.

6.1.2.7 Vacuum in Physics Classes in Ljubljana in the First Half of the 19th Century

After the reestablishment of Lyceum in Ljubljana on 24 April 1788, physics was taught by the former Jesuit Jernej Schaller, born in the Viennese suburb in 1745. After his illness, he was replaced by Neumann from Moravia from 3 March 1803 until autumn 1806. Later, Neumann became the professor of popular astronomy and physics at Joanneum in Graz until he went to Vienna. Neumann published a *Compendiaria Physica* textbook in Graz from 1808 to 1812; in the German translation it became the *Lehrbuch der Physik*. The book was purchased immediately after the print for the Lyceum Library in Ljubljana. The former Neumann's Lyceum student Kersnik, a grandfather of renowned writer, used it in his Latin physics classes for the freshmen at the Faculty of Arts of the Academy of Ljubljana in 1810/11. Kersnik is one of the most proficient physicists in Slovenia, because he taught physics since 10. 12. 1808 until his death; almost forty-two years. During the French occupation, he was a professor of physics at *Écoles centrales* in Ljubljana, the capital of the Illyrian Provinces. In 1811, he catalogued Magdeburg hemispheres and other devices in the physics-chemical cabinet in Ljubljana. After the restoration, Janez Kersnik taught physics at Lyceum in Ljubljana according to the textbook of the Piarist Remigio Döttler. Döttler took over the lectures of physics and mechanics at the University of Vienna after Ambschell (1804-1809) and retained the chair until his death in 1812. Döttler's textbook was not based on Bošković's dynamics anymore, but it still distinguished between general and special physics. Guericke's experiments, the consequences of dilution and air compression and the production of various Torricelli tubes or barometers were discussed in the first chapter of special physics.⁵⁴³

For a half of decade, Hummel from Moravia was Kersnik's colleague in Ljubljana. Hummel taught the elementary mathematics in the first year of Lyceum in Ljubljana from 1835 until his departure to Graz. In 1850 at Graz University, he became the first professor of physics and retained the chair until his retirement on 31. 5. 1867. Before his appointment to post of a substitute (suplent) teacher, and in 1837 as a full professor in

⁵⁴² Vega, 1800, paragraphs 62–66, 70–74, 76, 80–82.

⁵⁴³ Döttler, 1815, 1: 12–15, 33, 2: 4–25.

Ljubljana, he made a device for the improved fermentation of wine and beer in 1821.⁵⁴⁴ In the fermentation machine, he used gaskets and recipients that were characteristic of the then vacuum and overpressure devices (Figure 6-6).

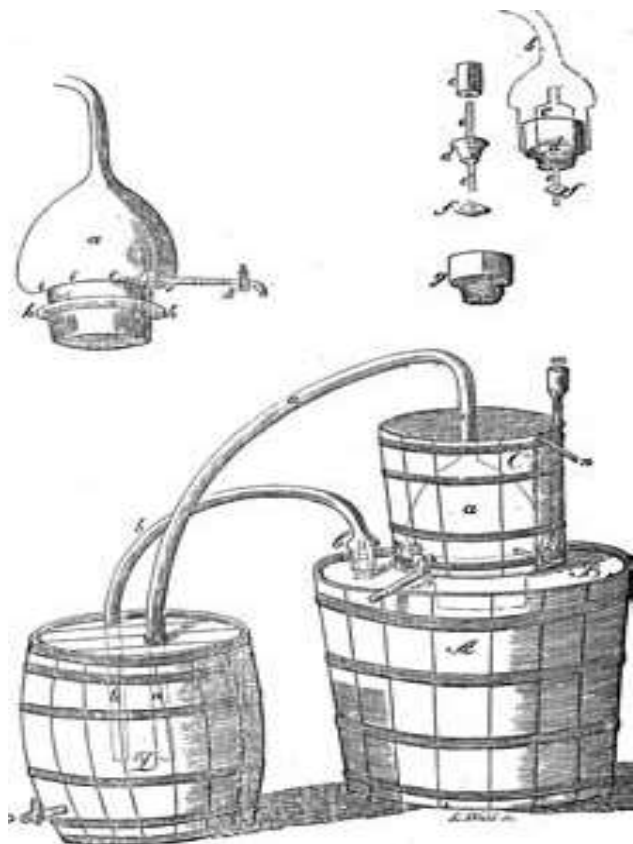

Figure 6-6: Hummel's Machine for the fermentation of wine.⁵⁴⁵

6.2 Vacuum Related Books on Slovenian Soil

What was the education of the first Slovenian vacuumists? We will find the answer in books with descriptions of vacuum techniques of their times, but we will be able to tell less about vacuum devices in the then Baroque Ljubljana. Janez's brother Wolf Auersperg has filled one of his Ljubljana's rooms with unusual devices like "chamber of wonders" as Kircher did in Rome, but there is not enough information about any Wolf's vacuum devices in it. So, we have the first explicit proofs of the school's vacuum experiments in Ljubljana only on 17 September 1755, in Ambshell and Schaller's catalogues, and from

1811, a century after Auersperg's cooperation with Guericke in Regensburg.

Auersperg's library in Ljubljana might be the greatest private collection of his era, but the bulk of knowledge of his neighbours was still concentrated in local monastic libraries. The Slovenian ancestors were the descendants from Latin culture although their linguistic drastically changed. After the collapsed fall of Roman Empire, there was a long silence and disastrous lack of any great eruditions. Mostly through the preserved ecclesiastical Christian organizations the Slovenian ancestors soon met again with Latin culture which somewhat vanished after the collapse of Rome. They learned their forgotten erudition through the Benedictine monasteries in Štivan near Devin (Duino) from the 4th century to the 6th century, as well as from 7th century up to the 4th of July 1289 at St. Peter in Salzburg, where the Irish monk St. Rupert founded a monastery around the year 700. The Irish missionary methods were based on adapting to local conditions, which were later borrowed and developed by Matheo Ricci and his Jesuits in China, while the Irish folks resembled Slovenians in many aspects of their political and religious struggles in the following centuries except that the Irish hated master were English while the Slovenians had their similar troubles with racist Germans as well as with their own renegaded Quisling Germanized folks. The Irish encouraged regular reading of their faithful believers for the training and education of their souls. The Green Irish island was thus a bridge to the knowledge of the new Slavic settlers in Slovenian countries.

One of the most important then-existing libraries in the Slovenian lands belonged to the Cistercian monastery in Stična. Between 1140 and 1473 a Benedictine monastery in the Upper castle (Gornji Grad) in southern Styria was operating, and from 1183/84 the important Cistercian friars settled in Monošter (Szentgotthárd) on the former Slovene territory of today's Hungary.⁵⁴⁶ Among the most important libraries in the Slovene areas was the Cistercian stronghold in Stična, where the monasterial theological school and scriptorium was established in 1136 with the founding charter of the Patriarch of Aquileia named Peregrinus (Peregrin).

⁵⁴⁴ Hummel, after 1821, 49–56.

⁵⁴⁵ Hummel, after 1821, 56.

⁵⁴⁶ Bahor, 2005, 99.

Table 6-2: The leading promoters of the early modern new sciences in Carniolan libraries of their days⁵⁴⁷

Galilei	• Kepler
<ul style="list-style-type: none"> • Volf Auersperg owned <i>Opere and De proportionum</i> • The classmate of Janez Vajkard, Prince of Auersperg, Count Janez Ambrož Thurn-Valsassina had <i>Discorsi</i>.⁵⁴⁸ • Baroness Maria Theresa Oršić at the beginning of the 18th century owned <i>Discorsi</i>.⁵⁴⁹ • Ljubljana Jesuits had <i>Le operazioni</i> 	<ul style="list-style-type: none"> • Volf Auersperg possessed <i>Ad Vitellionem</i> • books of Janez von Pučar, inherited by dr. Franc Christoph Ott (Otto) in 1650⁵⁵⁰ • Ljubljana bookshop (Mayr, 1678, 79, 91) offered <i>Tychonis Hyperaspistes; Tabulae Rudolphinae</i>. • Ljubljana Jesuits used <i>Mysterium Cosmographicum</i> 1621; <i>Tabulae Rudolphinae</i> 1627. • Valvasor acquired <i>Ad Vitellionem, Dioptrice</i>. • Stična Cistercians catalogued <i>Tabulae Rudolphinae</i> 1627

Table 6-3: Auersperg and Valvasor's books from the Galilean Roman (Academia dei Lincei) or Florentine (Academia del Cimento) circle, Kepler's networks at the Palace of Rudolf II and Bacon's headquarters of later Royal Society

Author	Year	Title in Auersperg's library	Title in Valvasor's library	Title in Franciscan library in Ljubljana (if not noted otherwise)
Bacon, Francis	1654	Stubenberg's translations dedicated to Prince Janez and Count Wolf's Auersperg	/	<i>Historia ventorum; Historia vitae et mortis</i> (1636); <i>Historia naturalis</i> (1662)
Marquess Guidobaldo Monte	1577	<i>Mecanicorum liber</i>	German translation 1629	/
Galileo	1612; 1655-56	<i>Le operazioni del compasso; Opera</i>	Only letters in Kepler's book	/
Porta, Giovanni Batista	1650	<i>Magiae naturalis</i>	Translations: German 1612, Italian 1650, Latin 1680	Same also KSSKL-24; KSSKL-Kranj V 61
Porta	1650, 1652	<i>Physiognomoniae coelestis libri sex</i>	Italian Translation 1616	/
Schall von Bell, Adam	1665	<i>Historica narratio de initio et progressu missionis Societatis Jesu apud Chineses</i>	Same	/
Ferrante Imperato	1599	<i>Dell'istoria naturale</i>	/	/
Hernández & Cesi	1651	<i>Nova plantarum, animalium et mineralium Mexicanorum historia</i>	/	/
Kepler	1604	<i>Ad Vitellionem</i>	Same	/
Kepler	1611	/	<i>Dioptrica</i>	/
Redi, Francesco	1670	<i>Miscellanea curiosa medico-physica</i>	Four books of Redi's Florentine polemics with Kircher, among them two Latin about snakestone	/
Pallavicini, Marchio Sforza	1625	/	/	<i>Universa philosophia</i>
Viviani, Vincenzo	1746	/	<i>Elementi d'Euclide</i> 1-2	/

⁵⁴⁷ Štuhec, 1995, 80, 89-90.

⁵⁴⁸ ARS, SI_AS 309, Legacy Inventory archive, fascicle 46, technical unit 112, litera T, no. 1-11, here no. 7, p. 61; Štuhec, 1995, 90.

⁵⁴⁹ ARS, SI_AS 309, Legacy Inventory archive, fascicle 39, technical unit 78, litera O, no. 10, p. 68; Štuhec, 1995, 90.

⁵⁵⁰ ARS, SI_AS 309, Legacy Inventory archive, fascicle 34, Technical unit 81, litera P, no. 32, p. 68; ARS, SI_AS 309, Legacy Inventory archive, fascicle 39, technical unit 77, litera O, no. 1-8, here no. 2, p. 64; Štuhec, 1995, 90.

Table 6-4: Boyle's vacuum books at Valvasor's library (M) and elsewhere in Carniola

1665 ... Experimenta et considerationes de coloribus Londini: Herrigman (M). Inserted: Boyle, Robert. 1664. Brevis enarratio
1670 Paradoxa hydrostatica novi experimentis Rotters: Leers (M).
Nova experimenta pneumatica respirationem spectantia bind to Boyle's Exercitationes de atmosphaeris corporum consistentium: deque mira subtilitate, determinata natura, et insigni vi effluuorum. Bologna 1675 (Gerbec's library, today in Semeniška Library (SKLJ)).
1680 Opera Varia1. Nova experimenta physico-mechanica ... 2. Defensio ... gravitare aeris ... 3. Tractatus Mira aeris Experimentum nova de condensatione aeris 4. Tentamina quaedam physiologica ... fluiditatis et firmitatis5. Chymista scepticus ... 6. Paradoxa hydrostatica ... Geneva: Tournes (M).
1682 Die luftige Noctiluca Hamburg: Kosten (M).
1682 Experimentorum novorum physico-mechanicum continuatio secunda. Genevae. NUK copy bind to Sturm, Johann Christoph . 1685. Collegii Experimentalis Sive Curiosi. Pars secunda in qua purro praesentis aevi Experimenta & inventa physico-mathematica compluria, Speciatim Hygrostaticorum quorundam Instrumentorum, Siphonis Reflexi grandioris, Lachrymarum vitrearum, Clepsydrarum & Clepselæorum, Tubarum Stentorophonicarum sive Acusticarum, Hæmisphæriorum Magdeburgicorum,... Norimbergae: Wlfg. Maur. Endter. Valvasor had both volumes of that Sturm's book about Guericke's vacuum experiments in the edition of 1676 and 1685
1696 Opera omnia. Venetiis: Hertz (FSNM)

Table 6-5: Other Valvasor's Magazines (First Four Records) and Books on Vacuum Techniques Among his 79 works about Physics at Bogenšperk; they later went to Zagreb

Writer	Year	Title
	1671	Le Journal des scavants = Ephemerides eruditorum anni 1666. Lipsiae / Francoforti
	1690	Acta Eruditorum anno 1680 Lipsiae: Gunther
Oldenburg, Henry	1674	Acta Philosophica Societatis Regiae in Anglia anni
Oldenburg, Henry	1675	Acta Philosophica Societatis Regiae in Anglia anni 1665-1669 ... Amsterlodami: Boom
Cabeus, Nicolaus	1629	Philosophia magnetica ... Coloniae: Franciscus Sucus
Descartes, René	1690	Grundliche Beschreibung von Scharbock. Leipzig. V: Blanckaart, Steven
Harsdörffer, Georg Philipp; Schwenter, Daniel	1651-1653	Deliciae ... Nürnberg: Endter / Dümler (also in Stična, Auersperg's library and Janez Ambrož Count Thurn-Valsassina's collection; The Novo Mesto Franciscans had German translation).
Jungenickel, Andreas	1661	Schlüssel zur Mechanica ... Instrumenten der machination Nürnberg: Fürst

Table 6-6: Vacuum Technical Reading in the Volf Engelbert Auersperg's Ljubljana Collection

Writer	Year	Title	Schönleben's catalogisation
Magni, Valeriano	1654	Lux and tenebris lucens	56, polemical theology
Marci à Kronland, Joannis	1635	Idearum operatrici Idea. Prague. 4. Perg: (Parchment) White	317; 239
Marci	1662	Philosophia vetus restituta. Praga. 4 perg: (Parchment) White	342
Jakob Joannes Wenceslaus Dobrzensky de Nigro Ponte (Jakub Jan Vaclav (Wenceslas) of Chernego Mostu (Schwartzbrug), * 1623; † 1697)	1657	Fontes. Ferrara	325; 283

Table 6-7: Nineteen Kircher's books in Wolf's Library (sixteen different and two copies of Musurgia, Oedipis and Iter Extaticum I). Valvasor (M) acquired four Kircher's books and Capuchins in Kranj owned one of them

Year of bookplate	Year of print	Title, place, dedication	Page of Schönleben's catalogue
1655	1641	Artis Magnetica. Roma; Emperor Ferdinand III (Merill, 1989, 6)	327, Mathematics; 209; - (also in National Museum (NMLJ))
1658	1646	Ars Magna lucis. Roma; Ferdinand IV	-; -: - donated to Jesuits, now in NUK
	1650	Musurgia Universalis. 1-2, Roma, perg. (Parchment) Com.; Archduke Leopold Wilhelm	397, music; 211, 2: 314
	1650	Musurgia Universalis. Part 1, Roma, fol. Perg. (Parchment) White.	397, music; 212. Both parts also in NUK
	1650	Musurgia Universalis. Part 2, Roma, fol. Perg. (Parchment) White.	397, music; 212
	1652, 1654	Oedipus Aegyptiacus. Roma	
1658	1656	Itinerarium. Roma (gift of author = Donum Authoris (Sotheby's, 1982, 58))	329, Mathematics; 204; 1030
	1656	Structura globis Coelestis (Iter Extaticum I). Roma (2 copies)	327, Mathematics; 204, 205; 1032
1658	1657	Structura globis terrestris (Iter Extaticum II; Mundus Subterranei). 1-3, Roma	327, Mathematics
	1658	Scrutinium physico medicum. Roma. 4 perg: (Parchment) white	315, Medicine; 218; 1033 (Offered by Mayr in Ljubljana in 1678. 1740 Graz edition catalogued in W-1521 and NUK-11813. Gerbec had Leipzig edition of 1671, now in SKLJ which also has Kircher's Turris Babel, of 1679)
1663	1661	Diatribe di prodigiosis. Roma 8 cart, turquoise; Archduke Leopold Wilhelm (gift of author = ex dono Authoris (Sotheby's, 1982, 58; Merill, 1989, 36, 38))	233, Church history; 203
1664	1663	Polygraphia. Roma, gift of author in Rome	217

		3. 3. 1664 (Sotheby's, 1982, 60)	
	1667	Historia Chinensis. Amstelodami, fol. Perg. (Parchment) White	244, a sacred history; 202
	1667	Regnum natura magneticum. Roma. 4 perg: (Parchment) Old	337, Philosophy; 210
	1669	Ars Magna sciendi seu combinatorica. Amstelodami, fol. Perg. (Parchment) White	369, linguistics; 201
	1671	Descriptio Latium veteris et nova. Amstelodami, fol. Perg. (Parchment) White	244, sacred history; 208
	1654	... magnes sive de arte magnetica ... Romae: Masotti	M
	1667	... Magneticum naturae regnum ... Amsterlodami: Jansson	M
	1671	... Ars magna lucis et umbrae ... Amsterlodami: Jansson	M
	1678	...Musaeum celeberrimum .. Georgius de Sepibus Valesius authoris in machinis ... Amsterlodami: Jansson	M
	1739	De venenis liber physico-medicus publico commodo recusatus ... Graz: Widmanstad	KSSKL-Kranj V 72, Loka Y 16

The most abundant libraries with scriptwriting had the strictest Carthusian order of the Catholic Church. Their particularly rich libraries and scriptoriums were successively established in their four monasteries in Slovenian Lands. We do not know (yet) how to explain why such an interest of the Carthusians for Slovene ancestors; in any case, the actions of the Carthusian monks have greatly increased the level of astronomical, mathematical and literary education in Slovene places. However, the functioning of the Carthusian monks significantly raised the level of Natural History, mathematical, and literary education in Slovenian Areas.

As could be expected, most of the books including those related to the vacuum were initially kept in monastic libraries, which was especially true for now Slovenian areas where the monastic literati remained almost the only ones until the Renaissance. During the Habsburgian centralizations of Josef II, several monastic libraries were disowned with their books officially transferred to Vienna or to the Lyceum library of Ljubljana, but in facts many books were stolen. By the lucky coincidence even if many of these books are not in our evidence now, we still have access to the several variants of their catalogues to enable our search and valuations of knowhows about

vacuum among the early monks living at the areas of now Slovenian state. Certainly, far the most important library in the Slovene area was the Cistercians' library in Stična which was also sadly victimized by Josef's imperial reformers.

6.3 Books on the Vacuum once Owned in Cistercian Library in Stična of Lower Carniola

6.3.1 Introduction

Among the most important libraries in the Slovene area was the Cistercians' library in Stična. In 1136, the Patriarch of Aquileia Peregrin issued the founding charter of the local monastery with a theological school and scriptorium.⁵⁵¹ Six years later, the Cistercians founded a monastery in Vetrinje, which had similar significance for Carinthia (Koroška) and nearby Upper Carniola (Gorenjska) as Stična had for Lower Carniolan folks (Dolenjci). Especially rich scripting libraries have developed the strictest Carthusian order of the Catholic Church who established four monasteries

⁵⁵¹ Bahor, 2005, 100.

in later Slovenian places: Žiče (1164), Jurklošter,⁵⁵² Bistra (1260) and finally Pleterje⁵⁵³ of the Count Herman of Celje, who acquired the emperor himself for his son-in-law.

Pleterje monastery was abolished after its internal problems in the Protestant era in 1596, and the whole property was transferred to the Jesuits of Ljubljana.⁵⁵⁴ Only God knows the reasons for so much interest of the Carthusians for Slovenian ancestors. In any case, the actions of the Carthusian and Cistercian monks greatly raised the educational level in later Slovenian towns.

In 1576, 418 books with more than 650 texts were listed in the Stična monastery.⁵⁵⁵ The Abbot Maximilian Mottoch served in 1660-1680. He edited a library and archive. After him, the library was led by Janez Kočevar, Francis Plehan, and in the 18th century by Placid Peternel, Evgeny Wernegkh, Robert Kuralt and Bernard Schuderbach. Today the NUK stores the inventory compiled at the time of the abolition of the Stična monastery in 1784. It lists 2663 volumes,⁵⁵⁶ which, unfortunately, today unknown Cistercian divided between ten expert groups starting with bibles.⁵⁵⁷

The Aesthetic books followed,⁵⁵⁸ and after them the historical books;⁵⁵⁹ The fifth group listed the sermons.⁵⁶⁰ The fourth expert group is most interested in us as it included philosophical and physical work, descriptions of medical sciences and classical manuals under the reference codes SS and T.⁵⁶¹ It contained 263 works on philosophy and medicine and dictionaries. Of course, philosophy still included naturalistic works with numerous explanations of Aristotle's physics; then natural science included general science, medicine, pharmacology, astronomy, physics with vacuum experiments, chemistry, including even superstitions. The mathematics and physics-based work in Stična originated mainly from the former

⁵⁵² Established 1164/1174, after the year 1595 Jesuitical (Bahor, 2005, 264).

⁵⁵³ Established 1407, after the year 1591 Jesuitical (Bahor, 2005, 264, 267-268).

⁵⁵⁴ Dolinar, 2004, 136-137.

⁵⁵⁵ Bahor, 2005, 243.

⁵⁵⁶ Bahor, 2005, 106-107.

⁵⁵⁷ Anonymous, NUK Ms 22/83,1784, 1.

⁵⁵⁸ *Aestetici*; anonymous, 1784, 96,

⁵⁵⁹ *Historici*; anonymous, 1784, 103-107, 88-95.

⁵⁶⁰ *Prodiger*; anonymous, 1784, 107-.

⁵⁶¹ *Philosophia, medici, classici*; anonymous, 1784, 108-116^v, 96^f-106^f; Janeš, 2000, 27.

private library of the secular priest turned Cistercian Florjančič.

In 1783, on the General Cistercian Chapter, the abbots encouraged the heads of regular posts to purchase books in the field of physics, mathematics and sciences, and especially the useful works of horticulture with forestry. At the abolition of the monastery, there were about thirty mostly Latin medical works in Stična. The monks read much less German or Italian books. More than a third of medical books were printed in the 16th century. Among the Stična codes of 12th Century they kept the various scriptures of the Irish monk Baeda Venerabilis (Bede, Beda, * 673 Jarrow in Durham; † 735 Jarrow) *Commentarius in Matheum (Explanatio super Matheum)*, *Expositio in Libros regum* and *Varia*.⁵⁶² which testifies to the early visits of Irish monks to Slovenian medieval ancestors. The oldest printings among Stična Incunabula were authored by Regiomontanus, Arnoldus de Villanova's Venetian incunabula *Opera medica et chirurgica* (1490),⁵⁶³ and a year younger the most popular witty Boethius physical reflection of *De consolatione philosophica*⁵⁶⁴ which was the most beloved among Carniolan high society readers.⁵⁶⁵

Arnoldus de Villanova (Arnaldus, * about 1235 near Valencia; † 1311 at sea between Naples and Genoa) learned Greek and Arabic at home; he successfully treated the Pope Boniface VIII, wrote about the philosophical stone, among the first distilled alcohol and described the carbon monoxide during the smoldering. The Ljubljana Lyceum Library also acquired its Venetian translation of Avicenna with Averroes' comments *In fine expletus est liber primus canonis quem princeps aboali Abinsceni de medicina edidit. Translatis canticorum Avicenne cum commentaris Averrois* issued in 1489.⁵⁶⁶

The Ljubljana Lyceum Library took over the books of the Carthusian monastery in Bistra five years after its abolition in 1782, together with the library of the Kostanjevica monastery. According to the census, the library in Bistra upon the abolition of

⁵⁶² NUK Ms. 18; Janeš, 2000, 40.

⁵⁶³ Janeš, 2000, 29-30; W-1584.

⁵⁶⁴ Janeš, 2000, 65.

⁵⁶⁵ L. Janeš, *ibidem*, 65.

⁵⁶⁶ NUK-11294.

Slovene naturalist **Ivan Dizma Florjančič de Grienfeld** (Janez, * 1. 7. 1691 Ljubljana; † 1758) was the son of a lawyer in Ljubljana the member of Academia Operosorum Ivan Štefan Florjančič de Grienfeld (* 1663 Ljubljana; † 1709 Ljubljana). Ivan Dizma completed philosophical-physical and theological studies at the Jesuits of Ljubljana. He was delighted with his professors' scientific sophistication that he even entered their order for two years, just like his father before him. Between 1733 and 1738 he was a priest in Šmartno pri Litiji where he arranged an observatory of astronomical phenomena and magnetic declinations. In next decade, he was a priest in St. Vid, near Stična, and before his death he found the last peace as a Cistercian in the neighboring Stična. In any case, he was among the most educated Cistercians in Stična, the most prominent in natural sciences and vacuum techniques; a large part of the monastic physical reading is adorned with his inscription on the bookmark. He left his own manuscripts, vacuum books and other books. He used Vlacq, Strauch and Sturm's tables, learned Wolff's mathematical technique. He used Winkler's book about the electricity, and Matheseophilus's solution of the ancient quagmire of the squaring of the circle (1733), which Florjančič strongly rejected in the manuscript. He also used five-hundred thirty pages long Johann Leonard Rost's (* 1688; † 1727) astronomical guide with fourteen sketches (Nürnberg 1726), which was finally enlarged by fourteen pages full of images. In the end, in the research enthusiasm, he stuck with the notes for the year 1700, for 1753, and for the day July 6, 1753. Then he observed the eclipse of the first satellite of Jupiter. He added on both sides written leaf list full of data about the Polar star and Tycho's constellation of stars noted for 1717; among them Florjančič was specially interested in Andromeda. It is quite probable that the Cistercians in Stična inherited from Florjančič's legacy also Jacques Cassini's (* 18 February 16; † 15 February 1756) Parisian mathematical writings (1749) and today lost Kepler's Rudolphine tables, which had been on sale in Ljubljana over a decade before Florjančič's birth in Ljubljana.

the monastery had 2900 books and manuscripts.⁵⁶⁷ Similarly, the Stična library was only taken over six years after the dissolution in 1784. The most beautiful Stična manuscripts from the second half of the 12th and the beginning of the 13th century used to be appropriated by the Viennese court library, but, of course, many were lost or slipped through the fingers of "conscientious" officials. Thus, only about two-thirds of the former library of the monastery in Stična is preserved in the NUK today.⁵⁶⁸ Most of the other expensive stuff just – disappeared. According to Ž. Zois' report, a guy could buy a manuscript or even incunabula for a price of 1 kg of bread in Ljubljana in those dunny days.

The last abbot in Stična was Višnja Gora native baron **Franc Ksaver Taufferer**,⁵⁶⁹ who had two brothers priests: Jakob Jodok died in 1810 as a provost and canon of monastery of Augustinians in the town of Vorau in Styria northeast of Graz, while Inocenc became an important Jesuit in Ljubljana and professor of physics in 1760. Franc Ksaver studied in Germanicum in Rome between 1752 and 1756 and received his doctorate there. In March 1756 he was consecrated, and in 1764, he became an Abbot in Stična. Despite his Lower Carniolan origins, he took care of every coin of wealth for his reasonably well-built constructions like a guy from the Upper Carniola (Gorenjska) region or the Scotsman would do. His ways of heading of the monastery caused quarrels and the departure of the newcomers like Gollmayer, Kuralt and the later famous Anton Tomaž Linhart. The Abbot even suffered under the humiliating interrogations of Maria Therese's officials as all sorts of triable bothered his poor greedy head.⁵⁷⁰

6.3.2 *Cistercian Vacuum*

The first-class domestic library of Cistercians from Stična was largely supplemented with Florjančič's heritage. The Cistercians from Stična were well established among the Ljubljana scholars and technicians. Thus, a few days after the death of

⁵⁶⁷ Minařik, 2000, 578.

⁵⁶⁸ Mlinarič, 1995, 871-872.

⁵⁶⁹ Jurij Jožef Dizma (Franc Ksaver) Taufferer (* 22. 3. 1733 Tum by Višnji Gori; † 23. 3/5. 1789 Ljubljana).

⁵⁷⁰ Bahor, 2005, 101.

Anton Čokl (Tschokl, * Vienna; † 8 February 1779 Ljubljana), his chair on the Ljubljana Lyceum was taken over by Jožef Andrej Novak (Novak, Novakh, Baptized as Josef, 1750 Gorizia-15. 4. 1888 Stična).⁵⁷¹ In 1767 Jožef Andrej Novak made regular vows and became a profess of the Cistercian abbey in Stična, which he left for a while during his service in Ljubljana. Despite the simultaneous professorship in Ljubljana, he was an archivist and abbot's secretary when the monastery was abolished in Stična in the year 1784.⁵⁷² Besides the archive, he certainly also carefully looked upon the library too. Unfortunately, Novak sharply contradicted the researcher of the vacuum and compressibility of water, the Ljubljana rector Anton Amschell.

They quarreled for the proof of the immortality of the human soul; therefore, they had to transfer both of their non-gambling souls to Vienna, after the whole of Ljubljana's faculty of theology moved to Innsbruck for a few years while the faculty of philosophy was abolished until the ex-Cistercian Linhart asked for the return of philosophical studies to Ljubljana.



Figure 6-7: Florjančič measuring instruments published along his map of Carniola (1744).

The Stična Cistercians underwent new vacuum and other experiments under Florjančič's influence. They even knew how to predict the weather from the behavior of human fish Proteus fished in the surrounding area, which they nourished for that purpose in the monastery. They told many people about mysterious underground animals Proteus including the owners of the surroundings of Stična, barons Zois. Together with Zois, they worked

⁵⁷¹ Novak (Schmidt, 1963, 165, 269).

⁵⁷² Mlinarič, 1995, 796, 858; Sodnik-Zupanec, 1975, 183.

diligently in the Carniolan Agricultural Society, which in two decades of operation (1767-1787) successfully played the role of the domestic academy, and deeply interfered with the development of Carniolan physics, fertilized by vacuum technique. Every year, the society has been awarding prize-winning questions. In 1767, the very first reward went the manager of the Rifno (Rifnik, Raicheneck, Reichenekk, Reichenegg) estate by Celje south of Šentjur Franz Jamnik. On 23 November 1768, the Society also praised the Jesuit Pogrietschnig's paper on the Common pastures under the motto *Labor omnia vincit*.⁵⁷³ Dr. Ivan Jožef Anton von Haymonn (Haymann, Haiman, Haymon, * 1722 Postojna; † 1799 Ajman's (Ehrenau) castle by Sveti Duh by Škofja Loka), together with the procurator and prelate of the monastery in Stična, evaluated the answers. Postojna Jew Haymonn from the old Carniolan family wrote papers about fertilization, just like Pogrietschnig;⁵⁷⁴ of course, the Cistercians in Stična did not forget to acquire Haymonn's books, perhaps during his collaboration with the prelate of Stična In 1757 Haymonn studied his first year of theology in Graz. In the following year he was promoted to the Doctor of Medicine in the imperial



Figure 6-8: A hunter with an air belt around his hips crosses over water with a gun and a game for his dinner.⁵⁷⁵

⁵⁷³ Umek, 2006, 24.

⁵⁷⁴ Umek, 2006, 12; Schviz, 1905, 283.

⁵⁷⁵ Schwenter, Harsdörffer, 1636, 1: 468.

Vienna with a dissertation on air, various gases and vacuum. On this occasion, he thanked the Empress' Minister Gerhard van Swieten (* 1700; † 1772),⁵⁷⁶ and quoted Hippocrates, Jean le Clerc's (* 1657; † 1736) *Histoire de la Medicine*, Bernardino Ramazzini's *Dissertation, de Const. (De Constjtutjone [sic] Anni M. DC. LXXX. Ac De Rurali Epidemia, Quæ Mutinensis Agri, & vicinarum Regionum Colonos graviter afflixit, Dissertatio)* printed in Modena in 1691 and especially the famous Boerhaave's *Inst. Med.* with the description of the heat of the air.⁵⁷⁷ He examined Mariotte's research of the increase of air resistance with the square of the velocity of the projectile; he quoted Johann Rieger's *Introd. Rer. Natur.*,⁵⁷⁸ instructive Swieten's observations of animal behavior in a vacuum,⁵⁷⁹ mercury barometer, Réaumur's experiments, Stahl's exploration of burning, Fahrenheit's thermometer and scented evaporations.⁵⁸⁰ In fact, Haymonn's dissertation contained more physics than medicine; the wise man successfully practiced in Carniola, and he paid special attention to the equipment and business of pharmacies, so that before 1774 he became a medical councilor and protomedicus as a specialist of urologic and obstetrics. He married lady Angerburg whose father Janez Adam Gottfried Dinzl von Angerburg (* 9 November 1720 Zgornje Perovo) gave him the castle which got the name Ajman by Slavic misspelling of Haymonn's name.⁵⁸¹

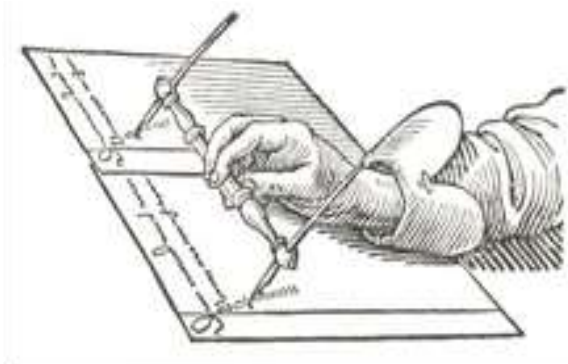

Figure 6-9: "Invention" for producing copies before the photocopier was available.⁵⁸²

⁵⁷⁶ Haymonn, 1758, 4.

⁵⁷⁷ Haymonn, 1758, 4-5.

⁵⁷⁸ Rieger, 1742/1743, Haymonn, 1758, 10.

⁵⁷⁹ Haymonn, 1758, 23

⁵⁸⁰ Haymonn, 1758, 25, 29, 32, 35, 56, 57.

⁵⁸¹ Pintar, 1925, 299; Schiviz, 1905, 406.

⁵⁸² Schwenter, Harsdörffer, 1636, 1: 48; Harsdörffer, 1651, 2: 48.

6.3.3 *Stična Books*

Georg Philipp Harsdörffer (* 1. 11. 1607 Nürnberg; † 22. 9. 1658) mailed eleven Latin letters from Nuremberg to the Roman naturalist Kircher in 1653-1656.⁵⁸³ Harsdörffer swore mainly on Francis Bacon;⁵⁸⁴ he even imagined an airy belt around the hunter's hips, to make it easier for him to cross the waters with a gun on his shoulder and a newly caught bird.⁵⁸⁵ After Porta and Ryffus' example, Harsdörffer described the siphon used to pump up water onto a hill, where he launched another pump.⁵⁸⁶ He liked the description of the winds in Venice, which blasted in their time also to the fun of the Protestant Megiser of Carniola.⁵⁸⁷

In 1651 and 1653, Harsdörffer added the second and third volumes to Schwenter's *Deliciae*.⁵⁸⁸ Cistercians in Stična acquired them. The Višnja Gora baron Maximilian Anton baron Taufferer bought *Deliciae* in the first edition of 1651, as well as in the second edition of 1677, and adorned them with his bookplates in 1720.



Figure 6-10: Illustration of the legend of the Archimedes' fire produced with focused mirrors during the defense of Syracuse against the Roman invasion in a book kept by the Cistercians in Stična

⁵⁸³ Gramatowski, Rebernik, 2001, 55-56.

⁵⁸⁴ Schwenter, Harsdörffer, 1636, 1: XV, XIX, XXI, XXII, 32, 156.

⁵⁸⁵ Schwenter, Harsdörffer, 1636, 1: 468.

⁵⁸⁶ Schwenter, Harsdörffer, 1636, 1: 480, 482, 495, 503, 541.

⁵⁸⁷ Schwenter, Harsdörffer, 1636, 1: 459.

⁵⁸⁸ Thorndike, 1958, 7: 594.

Table 6-8: Stična Books: Inventory of Natural Science, Physics, Mathematics, Building and Techniques of Vacuum research in Cistercians' library in Stična, mostly from Florjančič's legacy

Writer	Year	Title	Place: Publisher	Inventory pages
Sunczel, Friderici	1499	Collecta et ercitada in 8 libros Philosophorium Aristotelis and almo studio Ingolstadiensi	Venetiis: Jacobus Pentius	21/83 98r and 21/83 110v
Aristotelis, Argyropoulos	1500/1 508	Octo lib. Physicorum	Venetiis: Pentius	21/83 98r and 21/83 100r
Stoeffler, Joannis; Pflaumen, Jacob.	1507	<i>Almanach nova plurimus anis venturis inservientia, per Joanne Stoefflerinus Justingensem et Jacobum Pflaumen Ulmense accuratissime suppata et toti fere Europa dextro sydere impartita</i> (NUK- 4063)	Venetiis: Peter Lichtenstein	21/83 98v
Peter Apian (* 16. 4. 1495 Leising in Lower Saxony; † April 1552)	1533	Cosmographius liber oludore Colectus cum figuris, item horologio graphica Sebastiani	Münsteri in eodem volume Basileae	21/83 97v and 21/83 100r
Apian, De Piere	1551	La cosmographia	Paris	21/83 99r
Pontani, Joanis	1539	Liber de metheoris	Argentorati	22 / 83 109r
Harsdörffer, Georg Philipp	1653	Deliciae Mathematicae ...	Nürnberg	2 th & 3 th parts 21/83 99r
Lull, Raymundus	1666	Testamentum unikatam arte chimica completa. in octavo	Coloniae Agripina	22/83 109v
Scotteus, Herrn Konrad	1671	(Schott, Gaspar) Magia optica	Bamberg	21/83 98v
Hainlain (Heinlein), Petri Henrici ordini S. Benedicti	1675	Disputatio Physics of the Mundo et cielo, de elements et de meteoris	Salisburg: Mayr	22/83 109r
Meyer (Mayr), Wolfgang Augustin	1680	Lust-, Luft-, und Feuer Kunst.	In octavo Ulm	22/83 109v
Sperlette, Joanio	1694	Physica nova, sive philosophia naturae	Basilea	21 / 83 99r
Papi, Petrus Angelus	1706	Sacra authorum recentiorum Critica in Philosophia, Chimia et Medicina. Opus in tres tractatus distinctum. Authore Petro Angelo Papi Medico et Philosopho Sabinens (NUK-11474)	Romae: Herculis	22/83 109r
Bion, Nicolaus	1713	Mathematische Werck=schule oder Gründliche Anweisung wie die Mathematische Instrumenten mit schicken und recht zu gebrauchen, sondern auch auf beste und accurateste Manier zu Ververtigen, zu probiren, und allezeit im guten Stand zu erfulten sind (NUK-21406)	Nürnberg	21/83 98v
Amort, Eusebius	1734	Philosophia	Venetiis: Recurti	22/83 109v
Weidler, Johann Fridericus (* 1691 Großneuhausen in	1736	Institutiones matheseos selectis observationibus illustratae in usum praelectionum Academicarum.		21/83 97v 22/83 110r

Thuringia; † 1755 Wittenberg		Wittenberg: Ahlfred Editio nova (NUK-4075)		
Redlhammer, Joseph. S.J.	1745	Philosophia (probably: philosophia Rationalius 1752; Philosophia naturalis... Metaphysica Cosmologia 1753)	Vienna	22/83 109v
Redlhamer, Joseph. S.J.	1755	Philosophia naturalis, pars prima; Seu, Physica generalis ad praefixam and scholon nostris normam concinnata.	Vienna: J. T. Trattner	424 pages with images 22/83 109v
Mayr, Antonius S.J.	1745	Philosophia peripatetica antiquorum principiis et recentiorum experimentis conformata, auctore R.P. Mayr Societatis are Sacrae Phliae Doctore et antehac in Universitate Ingolstadiensi Phliae ac Thliae Professore ordinario (NUK-4864)	Venetiis: Nicolas Pezzana	22/83 109v
Winkler, Johann Heinrich (* 1703; † 1770)	1743/1744	Gedanken von den Eigenschaften, Wirkungen und Ursachen der Elektricität, nebst einer Beschreibung zwo neuer Maschinen.	Leipzig: Breitkopf (ST-8113).	22/83 110r21 / 83 97v
Zanchi, Josephi S.J.	1748	Scientia rerum naturalium sive physica tomus primus et secundus. In one volume	Vienna Austriae	21/83 97v and 21/83 100r
Zanchi, Josephi.	1750	Philosophia mentis et sensuum tomus primus	Vienna Austriae	21/83 97v
Erberg, Anton	1750	Cursus Philosophicus (NUK-5234)	Vienna	22/83 109v
Gusman, Julius Franciscos (Gusmann, * 1702; OAug; † 1776)	1755	<i>Dissertationes Philosophicae, quibus philosophia rationalis et naturalis nuper usibus academicis accomodata ex Magni Patris et Ecclesiae Doctoris D. Aurelii Augustini. Hipp. Ep. Autoritate et rationibus plurimum illustratur etc. Tomul. I. Philosophiam rationalem complectens Tomul. II. Tres priores Metaphysicae sectiones. Ontologiam, Altiologiam et Cosmologiam complectens. Tomul. III. Quator posteriores Sectiones Pneumatologiam, cum Theologia naturali, Angelographia et Psychologia complectens Tomul. IV. Physicam generalem Tomul. V. Physicam particularem complectens. in octavo (NUK-4866) Ad ligate: Assertiones. Franciscos Salesius Taufferer... Albin Spandl Canonicus Regularis lateranensis S. Augustins... Gregor Lainix Phil. Prof. Jerome Rechpach etices Prof... Joseph Mayer Prof. Matemat. Quarto</i>	Graecii: Haeredum Widmanstad	22/83 109v
Giovanni Antonio Lecchi	1752	Arithmetica universalis Isacii Newtoni sive de compositone et resolutione, arithmetica perpetuus commentariis illustrata et aucta. In 8to (NUK-4123; ST; ER-30 9)	Mediolani (Milano): Jos. Marelli *	22/83 110r21 / 83 97v
Lecchi	1773	Memoire idrostatico-storiche	Modena: Società	22/83 110r

			Tipografica	
Rieger, Christian S.J.	1758	Universae Architecturae Militaris Elementa brevibus ... Soc. Iesu Sacerd. Mariae Theresiae Augustae honoribus d(ed icata a Joanne Baptista L. B. De Schilson, dum idem sub augustissimis auspiciis in collegio regio Theresiano S. J. tentamen publicum ex disciplinis philosophicis atque historicis subibat (ST; NUK-8123).	Windbone: Joannis Thomae Trattner	21/83 99v
Mako, Paul von Kerek-Gede S.J.	1762	Compendiaria Physicae Institutio quam in usum auditorium philosophiae. I-II Vienna. Expanded Reprint: 1766.	Vienna (ST) Vienna: Trattnern	22/83 110r

Table 6-9: Medical, chemical and biological books related to vacuum techniques in Cistercians' collections in Stična

Author	Year	Title	Place: Publisher	Inventory pages
Agricola, Georg	1546	De natura subteraneum Basileae:	Basileae: Froben	21/83 103v
Philippus Aureolus Teofrastus Bombastus von Hohenheim Paracelz (Paracelsus, * 1. 5. 1493; † 24. 9. 1541 Salzburg)	1603	Opera medico-chimico-chirurgica	Nurenberg	21/83 105v
Glauber, Johann Rudolph	1652	<i>Furni novi philosophici oder Beschreibung einer New-erfundenen Destillir-Kunst: auch was für Spiritus, Olea, Flores und andere dergleichen vegetabilische, animalische und mineralische Medicamenten, damit auffeine sonderbare Weise gantz leichtlich mit grodden Nutzen können zugerichtet und bereytet werden. Auch wozu solche dienen, und in Medicina, Alchimia und anderen Künstler können gebraucht werden. Allen Liebhabere der Wahrheit und spagyrischen Kunst zu Gefallen an Tag gegeben</i> (NUK-11791; NUK-11793; also V (Valvasor's book) (New Philosophy or the description of Spiritus, Olea, Flores and other vegetative, animal and mineral medicines, and weeded a lot of Weise utilities)	Frankfurt am Main: Matthia Mariansel	21/83 100v
Glauber, Johann Rudolph	1651	<i>Operis Mineralis oder Vieler... 2 Theile = Operis Mineralis oder vieler Künstlichen und nützlichen metallischen Arbeiten Beschreibung 1- 3 part...</i> (NUK-8991)	Behrenberg = Frankfurt am Main: Mariani Erben	21/83 100v and 22/83 110r
Haymonn, Joseph Anton	1758	Dissertatio physico medica de aire (W-1432, NUK-8184, ER-physics 25)	Vienna: Kaliwoda	21/83 101r

By **Johann Rudolph Glauber** (* 1604 Karlstadt; † 1668 Amsterdam) we call Glauber's salt, the sodium sulphate. Glauber was curious about many sciences. He spent his youth during the Thirty Years' War in Viennese cosmopolitan world, then traveled along the Rhine Valley, finally settling in Amsterdam for two decades, where he rebuilt a former alchemy house for modern vacuum and chemical experiments with burners and distillation devices. He became wealthy so he hired five or even six assistants, as he had a lot of income. Glauber's vacuum-related procedures and chemical ideas were sufficiently popular for the Cistercians in the Stična to buy as much as two of his books.

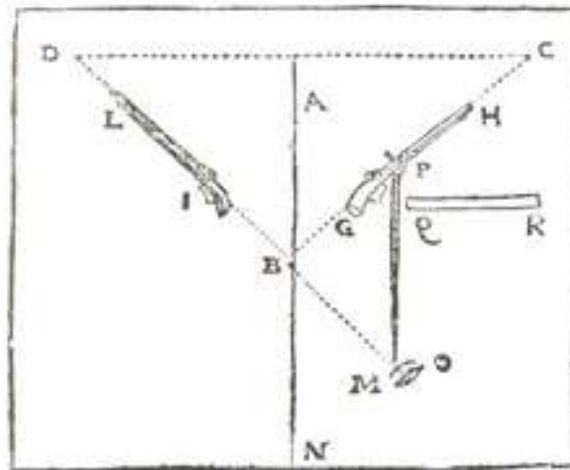
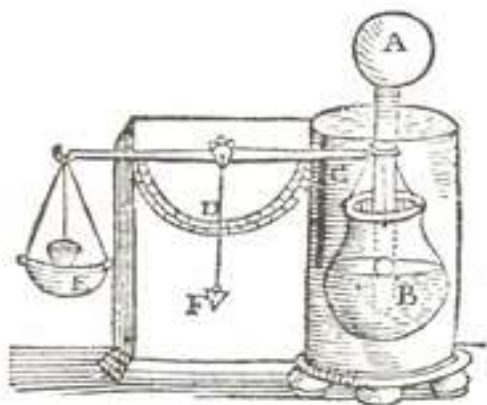

Figure 6-13: Target with a rifle in a mirror image.⁵⁹²



589

Figure 6-11 : A sketch of air weighing in the Stična library; first performed by Koper native Santorio Santorio (* 1561 Koper; † 1636) as an introduction to Torricelli's vacuum experiments.⁵⁹⁰

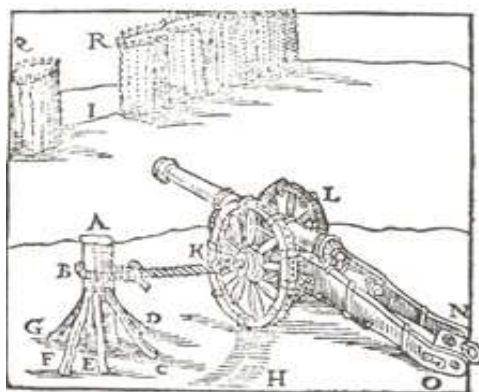

Figure 6-12: Fixed cannon to mitigate a recoil momentum.⁵⁹¹

⁵⁸⁹ Harsdörffer, 1651, 2: 258.

⁵⁹⁰ Harsdörffer, 1651, 2: 365.

⁵⁹¹ Schwenter, Harsdörffer, 1636, 1: 435.

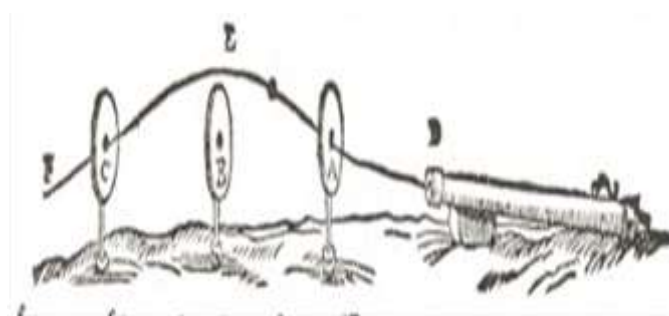

Figure 6-14: A sketch of the parabolic trajectory of a projectile in the former Stična Library.⁵⁹³

In the second volume, Harsdörffer described Marquess Guidobaldo Monte's moving images in perspective, Liceti's luminescence, and Mario Bettini's description of the burning with Archimedes' mirrors. He described Magni's and Kircher's experiments with a vacuum above the column of mercury, but he did not mention Guericke in this respect.⁵⁹⁴ He was interested in a Girolamo Fracastoro's magnet supposedly useful for moving iron through the air despite W. Gilbert's criticism. Harsdörffer praised Heron's sphere with an overpressure as an ancestor of the steam engine and Bacon's description of the winds; he conscientiously illustrated concentric circles cut from paper for the correct formation of German sentences, the testing of the Drebbel's submarine on the Thames and Furttentach's metal ship. After the ill-fated or maybe even useful habit of his days Harsdörffer ended his work with alchemy.⁵⁹⁵

⁵⁹² Schwenter, Harsdörffer, 1636, 1: 494/495.

⁵⁹³ Schwenter, Harsdörffer, 1636, 1: 423.

⁵⁹⁴ Harsdörffer, 1651, 2: 426, 453, 456, 464-467.

⁵⁹⁵ Harsdörffer, 1651, 2: 474, 478, 480, 482, 493-494, 589.

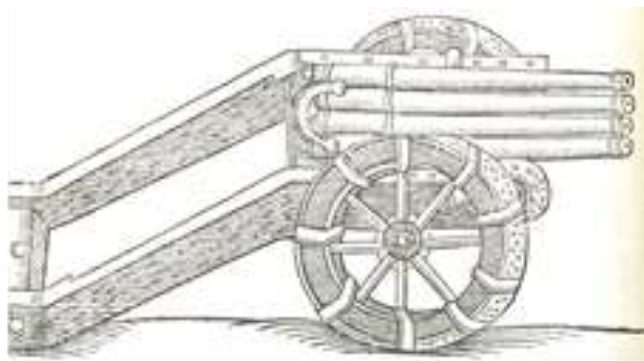

Figure 6-15: The cannon with four barrels which inspired the Cistercians in Stična.⁵⁹⁶

In his third book, Harsdörffer offered the reader a double feather for writing copies, Kircher's slightly missed Egyptian hieroglyphic research, Copernican Movement of the Earth, and the instructions of the Croat Marin Getdalić for weighing metals according to the provisions of the Archimedes' law.

Harsdörffer liked to play draughts (Checkers) or chess even with living figures: on the left he placed his female figures, and his right side was populated by male figures. The fortresses-castles, often referred to as elephants, were put in Spanish dresses, hunters were dressed in a Welsh costume, the farmers seeking for their transformations after reaching the end of the desk were courtiers or Garde-dames of the court.⁵⁹⁷ Harsdörffer described the static of the sloping towers in Pisa and Bologna, the domestic Native American use of tobacco, and especially the drive of ships without sails or rudders,⁵⁹⁸ which soon led to the invention of the steamer.

Harsdörffer described the old but still popular Torricellian experiment with a tube full of mercury tube, which he sealed with a finger and then turned clockwise quickly. Harsdörffer discussed Magni and Mersenne's experiments with Torricelli's vacuum, Pascal's barometric measurement of heights and the vacuum experiments of Kepler's Prague associate Benjamin Bramer.⁵⁹⁹

Harsdörffer offered many entertaining answers: How long do we live without eating dishes, Bacon's opinion on the use of salt, the afternoon's naps benefits... Harsdörffer provided thirty-four

⁵⁹⁶ Harsdörffer, 1651, 2: 510.

⁵⁹⁷ Harsdörffer, 1653, 3: 48, 73, 153, 308-309, 391, 405.

⁵⁹⁸ Harsdörffer, 1653, 3: 432, 462-464, 479; Harsdörffer, 1651, 2: 493, 659.

⁵⁹⁹ Harsdörffer, 1653, 3: 659, 466.

short, pleasant questions with answers suitable for evening social entertainment.⁶⁰⁰

The Cistercians in Stična did not avoid even using a vacuum in the military efforts at that time. Wolfgang Augustin Meyer (Mayr, Mayer) dated a preface to his military manual in Ulm on 8 January 1680. It was soon read by the Cistercians in Stična. The unusual book initially served thirty-eight figures - the pictures were followed by an initial chapter with descriptions of the tools.⁶⁰¹ Meyer then elaborated on the details of vacuum pumps and pumps with relatively complex seals and discharge openings conveniently adapted for pumping air out of the vessels. He added a description of big balls with water⁶⁰² and some smaller ones. He provided specific instructions on the preparation of the powder; he listed the masses of materials used with alchemistic signs for gunpowder, water, sulfur, turpentine, etc.⁶⁰³ It was convenient for the reader to read the instructions and quantities needed for mixing, describing the best rockets and vacuum pumps; he knew how to check the quality of the gun and the fireballs popular in those times.⁶⁰⁴ Loth was used to measure the mass, which weighted close to 13 grams.⁶⁰⁵ The flammable substances were made from arsenic and sulfur. He summarized even the advanced artillery use of geometric devices, while he listed various useful types of firearms.⁶⁰⁶ The second part of a book was compiled by Wurttemberg prince's engineer the captain Marx (Markus) Eysenkrämer von Bissigheim who resided in the house of the future apothecary in Besigheim 20 km north of Stuttgart in 1603-1634. For the instructive end Eysenkrämer listed ten rules of an expert artilleryist,⁶⁰⁷ trained in his dealings with a vacuum formed in a cannon tube.

Despite the rivalry between their orders, the Cistercians in Stična did not avoid even Jesuit writing about a vacuum: the desire for knowledge does not recognize secular restrictions. The Slovenian Jesuit Janez Baptist Cruxilia (Križnič, * 23. 6. 1623 Tolmin; † 1684 Klagenfurt) began his book stored in a monastery in Stična with the

⁶⁰⁰ Harsdörffer, 1653, 3: 541-544, 551, 566, 656.

⁶⁰¹ Meyer, 1680, 1.

⁶⁰² Meyer, 1680, 13-14 and figure 27.

⁶⁰³ Meyer, 1680, 24.

⁶⁰⁴ Meyer, 1680, 25, 26, 32, 33 39, 56.

⁶⁰⁵ Meyer, 1680, 34.

⁶⁰⁶ Meyer, Eysenkrämer, 1680, 35, 45, 51-53, 72.

⁶⁰⁷ Meyer, Eysenkrämer, 1680, 74-75.

discussion of logic and continued with physics on 94 independently numbered pages. He devoted the third part to mathematical physics on fifty pages. He continued with physics-ethics on 38 pages and added the last part, metaphysics. He dedicated his work to Emperor Leopold I. The book was published in the form of a Philosophical and Physical Examination at the University of Graz, where he tested his Graz native student Gregor Sigfrid Count Dietrichstein without any sharp questions as the Dietrichstein family used to be one of the most powerful in all monarchy. Dietrichstein studied for his baccalaureate in philosophy. The conscientious student first considered Aristotle⁶⁰⁸ in blind faith that nature opposes the installation of a vacuum; physics of empty space should be diabolical, but God is able to even work with it. He did not describe in detail the two decades old Torricellian experiment. The mathematical physics followed, and physics astronomy was next. The treatment was crowned by the technical physics, which Dietrichstein connected with the static of vacuum related tools and other machines.⁶⁰⁹ At the end, he listed the questions from all Cruxillia's exam areas on unnumbered pages.

The Protestant descriptions of the vacuum were not unwelcomed to the Cistercians of Stična; so, they read Johannes Sperlette's (* 1661 Mouzon in Champagne; † 5 February 1725 Halle) book dedicated to Friderik III Brandenburg, the ruler of Prussia and the city of Magdeburg, where until recently the famous vacuum researcher Otto Guericke excelled as a mayor. Sperlette was a Huguenot which forced him to abandon France after the eviction of the edict of Nantes. In the time when he published his *Physica nova* he served as the rector and professor of philosophy in French Grammar school of Berlin. Sperlette was a gymnasium rector, the Doctor of philosophy and a public professor, according to today's terminology, a regular full professor. In the subheading, he listed mathematics with the explanation of the inevitable laws of motion. The real principles of the bodies followed and the description of the true nature of the vacuum.⁶¹⁰ In the title, he announced the images which he put in between the text; he drew a nice illustration of the law of refraction.⁶¹¹ To his notes on Euclid he added a picture and illustrated

Descartes' vortexes for the nice pictures.⁶¹² In the second part of the book, he reported on the Zodiac, the »fixed« stars, gravity and lightness, as well as the rain.⁶¹³ To conclude, Sperlette served his questions from all physics: in Question 5, he exposed the supposed error of Epicurus and Gassendi. He refused any existence of the atoms with an intermediate vacuum included. He devoted the 42nd question to the local motions, and his 126th question to the Moon.⁶¹⁴

The famous **Josip von Zanchi** (* 23 August 1710 Rijeka, † 1786 Gorizia) represented the new streams of Viennese students of Boerhaave's ideas in physics and philosophy. Zanchi was born in Rijeka in a patrician family. He entered the Jesuit novitiate in Vienna in 1725. He taught at the college in Gorizia and published a book with historical and scholastic content. In the years 1741-1752, he taught mathematics, logic, physics, metaphysics and ethics at the Viennese Theresianum and at the University of Vienna.

Among the popular Cistercian authors in Stična was Eusebius Amort (* 15 November 1692 Bibermuehle in Bavaria; 5 February 1775 Polling); a famous scholar, canon, professor of theology, and a librarian in Polling forty kilometers southwest from Munich. In third part of his work which he described physics, Amort narrated about the systems of ideas of physics, as the astronomy of Ptolemy, Tycho and Copernicus. Basically, he addressed Galileo's ideas in Torricellian vacuum experiments with a barometer⁶¹⁵ and a thermometer.⁶¹⁶ The last ninety-three pages of special physics Amort devoted to metaphysics, which sounded more like a pendant than anything like a special fourth part of a book. At the conclusion, he filled his first five tables with astronomical drawings. The sixth table dealt with barometer and vacuum techniques of his days, and the final three tables illustrated the biology of those times.

⁶⁰⁸ Cruxillia, 1662, 57.

⁶⁰⁹ Cruxillia, 1662, 863, 969, 1292, 1411.

⁶¹⁰ Sperlette, 1694, 13, 65.

⁶¹¹ Sperlette, 1694, 89, 97.

⁶¹² Sperlette, 1694, 40, 97, 149.

⁶¹³ Sperlette, 1694, 166, 171, 187, 213.

⁶¹⁴ Sperlette, 1694, 315, 319, 328.

⁶¹⁵ Amort, 1734, 3: 212, 213.

⁶¹⁶ Amort, 1734, 3: 235.



Figure 6-16: Zanchi's coat of arms.

The Cistercians of Stična read the textbooks of Zanchi,⁶¹⁷ who still did not accept the new Bošković's dynamic philosophy and physics; he based his explanation on Musschenbroek's Dutch version of Newton's physics, which was also very popular among the Jesuits in Ljubljana.

Zanchi restored Aristotle's science of matter and form in his double, metaphysical and physical sense. To his first book of "general physics" on three hundred eighty pages, he bound another book about the "special physics" with its own cover page and page numbering; both books eventually shared pictures. The first of these were interesting sketches of Magdeburg and other vacuum experiments, which stimulated the discussions already for centuries.

Zanchi divided his general physics into basic principles and observed types of bodies. In the second book, he described all three astronomical systems: Ptolemy, Copernicus, and Tycho's in the order of their origin. The role of water and fire in changing of the weather was followed. He came up with a special occurrence like the northern lights (Aurora Borealis), along with modern metallurgy

⁶¹⁷ Lovato, 1959, 135; Korade, 1990/91, 26.

and even alchemy.⁶¹⁸ Then, in turn, he dealt with phenomena outside of mechanics: fire and cold,⁶¹⁹ elasticity,⁶²⁰ and above all, magnets and electricity as unusual puzzles of those times.⁶²¹

At the promotion of his baccalaureate candidate the Count Ivan Patačić von Zajezda he translated into Latin Noël Regnault's critic on Voltaire's Newtonian work.⁶²² The book was later reprinted four times as it promoted Cartesians from French nationalistic approaches.⁶²³ It was purchased by the Cistercians in Stična, and at the same time by the Trieste and Ljubljana Jesuits.

The monks in Stična also bought books of their neighbor Jesuit (Franz Xaver) Anton Erberg (October 21, 1695 Dol by Ljubljana; † 3. 10. 1746 Ljubljana), the first Carniolan writer of the modern textbook about physics. Up to his age of twenty-five Anton Erberg attended lower studies in Ljubljana, studied philosophy, entered the society of Jesuits, passed his novitiate, led the congregation, lectured in upper and lower secondary schools. He thus became acquainted with the Ljubljana higher school, which he later led. Between 1720 and 1723, he studied theology in Graz and at the same time took care of the library. After he took his three vows in Judenburg, he returned to Graz and taught ethics and then a three-year course of philosophy with physics from 1725 to 1728. Anton Erberg lectured again in Vienna between 1729 and 1731. He gave a three-year course in philosophy. From 8 December 1744 until his death he was a rector in Ljubljana. After his death his fans published his Logics, General and Special Physics, and repeatedly reprinted his Dialectical philosophy. He compiled those books already during his teaching of philosophy in Vienna and Graz between 1725 and 1735; he postponed the publication in anticipation of the Maria Therese's Reforms, which in the middle of the century imposed a new modern approach to physics teaching. He died already before the changes of natural science curriculum in Ljubljana and other Habsburg colleges.

⁶¹⁸ Zanchi, 1748, 106, 113, 140, 219.

⁶¹⁹ Zanchi, 1748, 318.

⁶²⁰ Zanchi, 1748, 342.

⁶²¹ Zanchi, 1748, 355.

⁶²² Zanchi, 1748, 22.

⁶²³ Sodnik-Zupanec, 1943, 22-23; Martinović, 1992, 88, 90; Vanino, 1987, 183.

Stična's monks were interested in siphons and similar natural vacuum-related hydrographic puzzles on their domestic karst: therefore, they bought numerous works of Jesuit Lecchi. In 1765, Jesuit Giovanni Antonio Lecchi (* 1702; † 1776) published Bošković's letter on the principles for the convenient rules for measuring the water flowing in the basins; he added the process of calculating the average velocity of a fluid.⁶²⁴ Lecchi was the leading expert for Italian waters just like Grandi.⁶²⁵ He was a professor of mathematics in the university of Pavia, where Bošković taught later. From 1738 until the ban of the Society in 1773, Lecchi taught at the Brera University in Milano, where Bošković taught afterwards. Then, Lecchi became a court mathematician and hydraulician of Maria Theresa with 300 florins of his annual salary as a kind of predecessor of navigational director G. Gruber. On the request of the Pope Clement XIII he managed river currents in the province of Emilia-Romagna until 1769. In 1752, Lecchi published a book on Newton's infinitesimal calculus; so, besides Bošković, Lecchi became one of the first researchers of new physics and mathematics among the Jesuits working in Italian areas. But already on 27. 5. 1766, Bošković found that Lecchi's book contained the "wrong assumptions" of his enemy, the Parisian academician d'Alembert.⁶²⁶ In the beginning of 1774, in his letter to his pupil and associate Francesco Puccinelli (* 1741; † 1809), Bošković recommended Lecchi's work, but after Lecchi's death, he completely rejected him on October 25, 1780.⁶²⁷ At the same time, Gabriel Gruber equally changed his opinion on Lecchi; the man resented him for his sharp assessment against the Ljubljana Canal. Gruber was the student of Bošković's friends, while Lecchi belonged to the different networks.

Anton's physics was published as the second and third part of his philosophy needed for the higher education, while his *Institutiones dialecticae* was intended for lower levels of instructions.⁶²⁸ General physics was printed with Imperial

privilege on November 4, 1750, and special experiments and vacuum techniques were issued next year. Immediately after that, the imperial decree of 1752 ordered the formal division of physics lectures into a general and special part. Thus, the textbook with the authority of the late rector Anton Erberg supported the introduction of novelties into the study of physics.

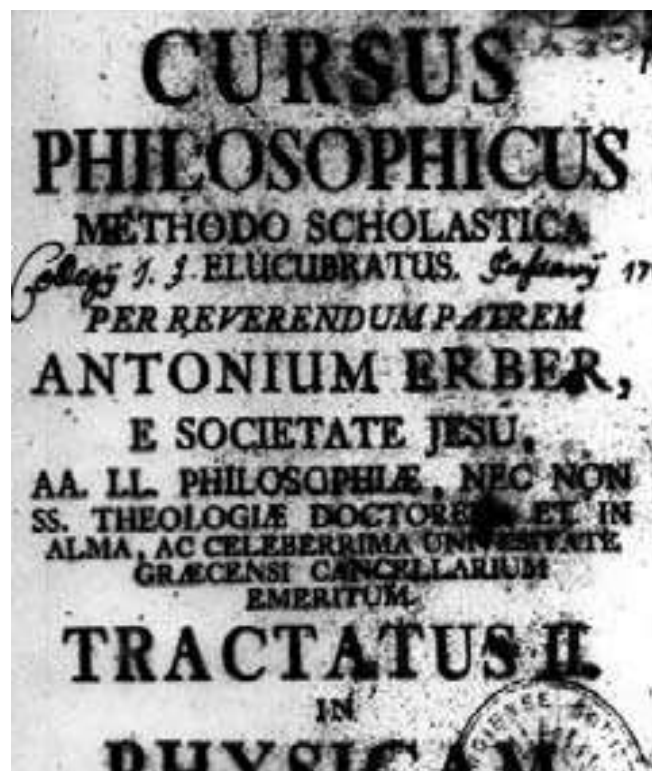

Figure 6-17: The title page of Erberg's *General Physics* (1750), the first book about physics of the Carniolan Jesuit scholar.

The monks from Stična lived in karst areas and were therefore very interested in Gruber's research, which "became productive" at his Ljubljana canal. In 1769 the Empress demanded a report on possible drainages of the Ljubljana moor. Gruber presented two proposals for the protection of Ljubljana from floods and the drying of the marsh at the invitation of the provincial Land Estates General in the same year. In the first he planned to deepen the Ljubljanica river for a very modest price of 74,271.42 guldens, while in the second one he was planned to spend somewhat more on canal, namely 82,744.17 guldens. The Gruber's canal was for only 10% more expensive, and Gruber supported that plan with all his might; of course, he cleverly presented the lowest possible costs in the hope that he would be able to increase them a little bit during the advanced course of his work.

⁶²⁴ Bošković, 1765, 319-345.

⁶²⁵ Abbé Guido Grandi (* 1. 10. 1671 Cremona; † 4. 7. 1742 Pisa).

⁶²⁶ Jean Le Rond d'Alembert (1717-1783).

⁶²⁷ Glonar, 1926, SBL (1925-1932) 1: 268; Martinović, *Filozofska* 1992, 82-83; Marković, 1969, 662, 822, 897; Bošković, 1980, 181, 190 (letters 28. 11. 1765, 27. 5. 1766).

⁶²⁸ Sodnik-Zupanec, 1975, 235.



Figure 6-18 : The cover of the book with Lecchi's criticisms of Gruber's ideas, which the Cistercians read in Stična.⁶²⁹

In 1770, a decree of the Viennese court ordered the creation of a special commission for the drainage of the Ljubljana moor. The members of the commission were the engineer Liber(ius) from the famous Ljubljana-based scholarly family, Gruber and the Milanese Jesuit Lecchi, who then resided in Ljubljana for a while. On the orders of the authorities, each of the three delegates communicated his opinion. In Milano, Lecchi received Gruber's plans to build a canal; he disliked the proposal, which caused grave problems to Gruber. Lecchi felt that a deepening and widening of the Ljubljanica riverbed should be a better solution. Gruber criticized Fremaut's proposals, as well as "P. Lechi (sic!), Milanese Jesuit and known mathematician" and the ideas of engineer S. Hubert. Everyone advocated the deepening, while Lecchi even favored the extended the riverbed of the Ljubljanica river. However, their solution did not seem much cheaper than Gruber's, and even houses near the Ljubljanica could be threatened, such as the home of Baron Zois on Breg. The most threatened would be the Jesuit college with its walls over the right bank of the Ljubljanica at the beginning of its current

⁶²⁹ Lecchi, 1773, 152.

through the then city of Ljubljana. Therefore, the Jesuits of Ljubljana wanted the canal. Gruber proved to be able to provide the local high-society support because he used to be first home teacher of Žiga Zois, and was also supported by Žiga's father, the richest Carniolan Michelangelo Zois. While Gruber introduced Žiga to the mystery of the latest vacuum findings, Gruber told to both Žiga and his father about the threat of their palace on the Breg (side) of Ljubljanica river if, God forbid, the authorities would accept Lecchi's proposal.

Lecchi published his critique of the Gruber's canal just before ban of the Jesuits on 23. 3. 1773, when the diggings of canal in white Ljubljana were already in full swing. By doing this, of course, Gruber's opponents were firmly supported, although at that time both Lecchi and Gruber were still the subjects to their Jesuitical order. Lecchi devoted his book to Francesco III⁶³⁰ from the house of Este, the Duke of Modena, Reggio, Mirandola north of Modena, etc. Lecchi dedicated his posthumous work with the related topics to the archduke Ferdinand,⁶³¹ the 14th child of Maria Theresa, who was married to Francesco's granddaughter and his only heiress, Maria.⁶³² Thus, Lecchi dedicated both of his basic researches to the dukes of Este and their Modena, where he planned several highlighted meliorations of the local waters. Of course, the Cistercians in Stična used to read both books.

Lecchi divided his book into two parts, which he tied together. He independently paginated each part. In his second part, he first presented his work on two Italian waters in two dissertations. He devoted much of his book⁶³³ to his vacuum-related hydrodynamic studies of the individual places of the German Empire in the years 1769, 1770 and 1771. In five sections he described his works in Šibenik of Dalmatia, on the Adige (Adiža) river in Trento, in Treviso, and by the Adriatic Sea in Ancona. He put his discussions about Ljubljanica river into the third section, which he sent to the Chancellor and Foreign Minister Kaunitz already on 27 February 1771. Lecchi referred to Gruber's

⁶³⁰ Francesco III Maria d'Este (* 2. 7. 1698 Modena; † 22. 8. 1780 Varese).

⁶³¹ Ferdinand Karl Anton Joseph Johann Stanislaus, archduke of Austria, duke of Modena (* 1. 6. 1754 Schönbrunn; † 24. 12. 1806 Vienna).

⁶³² Marie Beatrice Ricciarda d'Este, princess of Modena (* 7. 4. 1750 Modena; marriage 15. 10. 1771; † 14. 11. 1829 Vienna).

⁶³³ Lecchi, 1773, 79-195.

report and maps designed in the ratio of 1: 11300, so he did not even provide specific sketches of his own to his file. In three articles, he described the situation at that time near the Ljubljana River, recommended improvements and his final decisions, which, despite some complimentary comments on Gruber, strongly opposed Gruber's intentions focused on canal. Lecchi used Gruber's measurements of the fall, width, tributaries, banks and floods of the Ljubljana River. Lecchi began his description with a great deepening of the riverbed of Ljubljana below the Jesuit school where Ljubljana river enters the city of Ljubljana all the way to the house of Baron Codelli in the other side of then city; Codelli was an early friend and patron of Michelangelo Zois as both were native from Bergamo. Lecchi listed rapids and obstacles along the further flow of the traditionally sleepy river Ljubljana. Lecchi considered the level of the riverbed, the depth of the stream and the influence of the bottom. From experience in Ferrara, Bologna and during the regulation of the Reno river that flows into the Po River, he has realized the unsteady variability of the rivers which flow in flat plains. In addition to technical notes, he also used pleasant thoughtful descriptions of the "nature of the waters in their free stream" and advised: "Do not go too far from natural circumstances ... let the river be where it was for centuries."⁶³⁴ The Ljubljana river with Barje (Moors) valley was treated as a lake in a satisfactory way, as a lake that can rise its level by source, rains, sand ditches, mills and other circumstances.

In 1769 the professors Breguin and Marcy,⁶³⁶ as well as the cameral engineer Sigmund de Hubert (Hübert) assisted Lecchi in his measurements.⁶³⁷ Lecchi estimated the volume of material that should be removed at the beginning of the Ljubljana river and from its riverbed in the city itself; he intended to increase the speed of the river, so that during the spring floods the water level would not have risen for more than four feet. What obstacles does one had to overcome to achieve the desired flow rate? In the discussion, he expressed the opinion of Professor Gruber, although Lecchi felt that all data on the river flow was not available. Also, the complete destruction of the Ljubljana mansions storage facilities and mills because of the deepening of Ljubljana and

floods did not bother Lecchi much; in Lecchi's opinion, Gruber was supposed to spend the unknown higher costs for his canal. For this reason, he proposed the use of locks, as they had already done on Italian rivers. This, of course, was much cheaper, as instead of part of the human hands or very rare useful manufactured devices before the emerging vacuum technique of steam and mechanical machines, they could use the power of the river stream. The flow was supposed to deepen its own riverbed by itself in two or three years. A similar procedure, where the river itself was friendly digging its own bottom, Lecchi had previously tested for his drying works near Bologna; of course, the excavated bottom should be maintained every year. After the second year of work, the river should dig its own riverbed for two feet unaided, while in the third and fourth year it will dig up for two additional feet. New depths would contribute to the permanence of the riverbed. However, the deepening of the Ljubljana River would make the work of the mills impossible at the end of the city because the mills will remain too high above the water of river. Lecchi was sorry for them, "but such was the price of general well-being," he commented sarcastically.



Figure 6-19: Lecchi on the Ljubljana Canal with a critique of Gruber's ideas, read by the Cistercians in Stična.⁶³⁵

⁶³⁴ Lecchi, 1773, 152-173. Prince Wenzel Anton count Kaunitz-Rietberg (* 2. 2. 1711; † 27. 6. 1794).

⁶³⁵ Lecchi, 1773, 152.

Lecchi had some concerns, he did not look at Ljubljana's circumstances in detail but summed up his data mostly by Hubert's notes. Concerning the drainage, he referred to Gruber's sketches⁶³⁶ and considered the underground tributaries of the Ljubljana River. He advocated the preservation of old bridges and encouraged the installation of new ones; in any case, it was all still relatively cheaper than the canal.

In conclusion, Lecchi criticized the Gruber's Canal project, although he repeatedly referred to Gruber's sketch. The canal was projected in the middle between the two hills behind Codelli's house-castle; of course, the canal would take most of the waters from the original riverbed and increase its speed. However, after many years of experience, Lecchi supposed that without any obvious urgency it is not necessary to deal with such a costly and radical intervention. According to Lecchi, the Ljubljana already has a sufficiently large force at the Old Caves (Stare Jame) near the mill, where Gradaščica spills in, and the new canal overflow would, of course, reduce the force of water in the Ljubljana river. The redirection of parts of water into the canal would have shared some of the water that was available for the millings so far. According to Lecchi and by Galileo's student Castelli,⁶³⁷ the amount of water transferred is proportional to its speed,⁶³⁸ which of course is a very simplified D. Bernoulli's theorem. Such a stream would not by itself eliminate the threatening floods, as it would only work at relatively low water levels. In addition, the tributaries of the Ljubljana River bring a lot of material; they can even overflow a canal and prevent rotation of the mills.

Therefore, Lecchi cleverly described the canal as a peculiar risk and led the water to his own mill focused on deepening the riverbed. Finally, Lecchi added some glimmering hints about the private interests of people involved in planning the Ljubljana canal,⁶³⁹ which, of course, interfered with the very core of the problem focussed between the golden yellow crowns. Lecchi did not expose Codelli and Zois with their names, but all readers knew what was Lecchi talking about. Lecchi's deepening and expansion of the

Ljubljana riverbed would never spend so much money as the Gruber's canal, which at that time became one of the largest projects in the entire Habsburg monarchy.

On the other hand, Gruber presented his canal with flows, falls, and underground vacuums while using the support of major Struppi⁶⁴⁰ and Hubert.⁶⁴¹ Baron Zois and a lot of other Carniolan wealthiest folks were supporting Gruber; so, on March 9, 1771, ten days after Lecchi's report to Kaunitz, the Viennese authorities decided to prepare the money and give Gruber a green light. Lecchi's luck began to fade, and soon after him Kaunitz's star was in decline, while Gruber's reputation grew steeply. Lecchi died at a time when Gruber was still working on a canal; in the posthumous issue of his works on the waterways in 1776, he no longer mentioned the dispute around the Ljubljana River, but rather concentrated on the waterways in the areas of Milano, Modena, Reggio and Venice.⁶⁴²

6.3.4 Conclusion

For centuries, the Stična Cistercians built their base of learning in Lower Carniola (Dolenjska), and they also intervened in the field of technique and vacuum devices closely related to the regulation of karst waters in their immediate Ljubljana neighborhood. In the early days, they accepted the correct interpretations of early vacuum experiments, especially from the books inherited by Florjančič. Unfortunately, half of a decade after Florjančič's death, the monastery in Stična was recklessly abolished and many of the literary treasures were forever lost on their way from Stična to the white Ljubljana or to the Viennese metropolis.

⁶³⁶ Lecchi, 1773, 162.

⁶³⁷ Abbé Benedetto Castelli (* 25. 4. 1577 Brescia; † 1644).

⁶³⁸ Lecchi, 1773, 168.

⁶³⁹ Lecchi, 1773, 173.

⁶⁴⁰ Vincenc Jurij Strupi (Struppi, * 1733; † 1810).

⁶⁴¹ Kopatkin, 1934, 9.

⁶⁴² Lecchi, 1776, 169.

6.4 Capuchin and Franciscan Vacuum in the Middle of the 17th Century

6.4.1 The First 800 Years of Franciscan Vacuum for Slovenes

6.4.1.1 Introduction

The Friars Minor Franciscans with St. Francis' guide to the collection of scriptures in honorable places strongly influenced the development of libraries among Slovenes and, basically, the reading of natural science books related to vacuum research. They were and still are the most numerous religious order in Slovenia. In Slovenian country, they established themselves in all three branches: Franciscan Friars Minor Observants, Friars Minor Conventuals (Minorite) and Capuchins. Many Slovenian scholars were studying with Franciscans and often joined their monastic order. Who were the Franciscan vacuumists on the southern slopes of the Alps?

6.4.1.2 Vacuum in Kamnik

In the monastery in Kamnik the Franciscans led the elementary school, later even the secondary Latin school-gymnasium transferred from Kostanjevica above Gorizia to Kamnik. In their Kamnik library, the Franciscans kept the medicine of the famous Helmont. Perhaps it was the son of the famous "erudite" Janez Vajkard, the Kamnik guardian Donatus Valvasor, who was interested in exploring the vacuum as he learned a lot about it in his father's library at Bogenšperk?

After his group portrait with his son (and publisher), Francis Mercurius van Helmont, J. Helmont dedicated to his son his own medical and chemical work at the end of the Thirty Years' War. He described four ancient elements, and especially the gas and nature of the vacuum with criticism of Aristotle included.⁶⁴³ He did not know Torricelli's experiment, since he designed it in the year of J. Helmont's death. Helmont described the magnetic force⁶⁴⁴ and especially Paracelsus; the son-publisher added many amazing stories about the

effectiveness of the philosophical stone,⁶⁴⁵ for which Father Helmont certainly would not put his hands in the fire. The ancient theory of four elements was still a part of science as the Ljubljana bookkeeper Mayr sold data about it in the astronomer Trigler's⁶⁴⁶ and many other books which even the Franciscans of Ljubljana bought for their library.

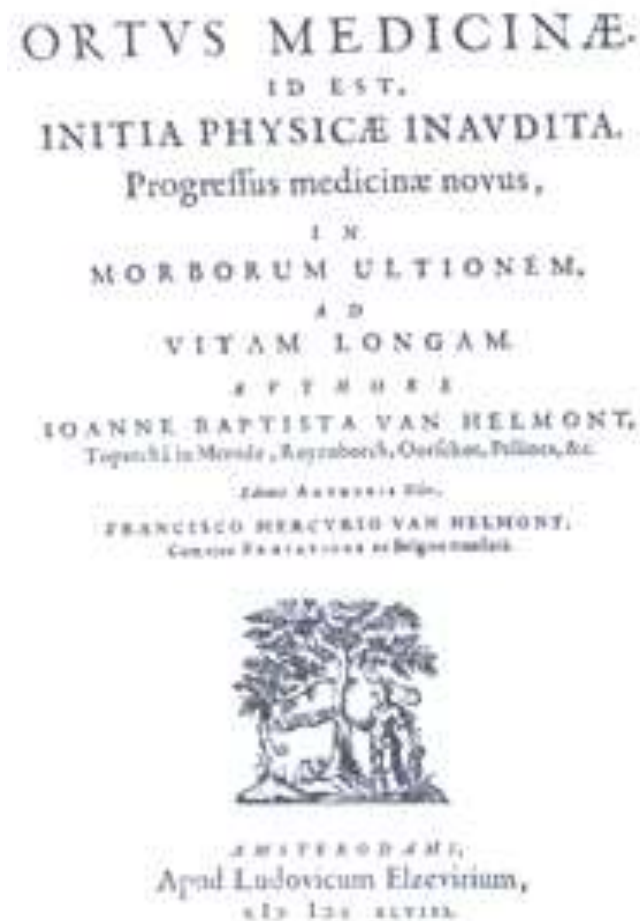

Figure 6-20: The title page of Helmont's book in Auersperg's library, also kept by the Franciscans in their library in Ljubljana.

The provincial Governor Volf Engelbert naturally did not want to be left behind the Franciscans of Kamnik. Therefore, he bought the same Helmont's work for his library in Ljubljana in a slightly older edition. He collected several hundred pages of Helmont's previously unpublished criticisms of Galen's advocates, the descriptions of fire, illnesses

⁶⁴³ Helmont, 1648, 83, 87.

⁶⁴⁴ Helmont, 1648, 612-614.

⁶⁴⁵ Grdenić, 2007, 298-299.

⁶⁴⁶ Helmont, 1648, 785, 787; Trigler, 1678, 12-13.

and, above all, plague in four specially paginated works.

According to the Franciscan Kamnik monastery catalog from 1760, medicine with surgery, anatomy and botany was included into twelfth expert group, while the philosophy with mathematics, meteorology and arithmetic belonged to the tenth expert group. Both groups also included vacuum books. Among the medical books were the works of authors like Levinus Lemnius, the Jesuit vacuum researcher Gaspar Schott and Stahl; Newton's Optics with the addition of his papers published in Phil.Trans. were bought in a Latin Clarke's translation issued by the Graz Jesuits.⁶⁴⁷ Typically, in addition to the Erberg Barons in the Slovene area, only the Franciscans of Kamnik and Novo Mesto (New City) enthusiastically bought Newton's works with modern conceptions of atoms and intermediate vacuum, as only those Franciscans taught to their students the physics doctrines at sufficiently higher level.

6.4.1.3 The Vacuum-related Books among the Škofja Loka Philosophical and Physical Writings

The Upper Carniola Capuchins first settled in Kranj (1640) and only on 28 April 1707 in Škofja Loka; however, after the abolition of the Kranj monastery (1786), the books of Kranj Capuchins were transferred in their neighboring Škofja Loka Capuchins' headquarters⁶⁴⁸ together with the individual writings of the Novo Mesto (New City) Capuchins.⁶⁴⁹

The Škofja Loka Capuchins loved to read the old good Albertus Magnus; they especially preferred his mineralogy, but less his physics or astronomy.⁶⁵⁰ Albertus' biography was obtained from Trithemius' Benedictine Pen as an introduction to Albert's mineralogy with botany, which is also preserved today in NUK in two pocket editions without bookplates.

The courageous Škofja Loka Capuchins did not refuse Protestant books if they only helped to

clarify the mysterious properties of vacuum. They stored a book of Wroclaw Lutheran Daniel Sennert, a professor of medicine in Wittenberg (1603), where he taught together with his brother-in-law Michael Döring. Sennert combined the obsolete Galen's medicine and Aristotle's doctrine with the criticism of Paracelsus's novelties in his promoting of the advancement of atomism; it became the mainstay of Boyle's thinking about the vacuum.⁶⁵¹ Volf Engelbert Auersperg obtained two Sennert's books, and in May 1678 Mayr offered to his Ljubljana clients in addition to two Sennert works also the Jakob Barner's (1641-1709) book on Sennert's medical systems. Barner taught medicine and chemistry in Padua and Leipzig. In Ljubljana, they stored two reprints of Sennert's medical letters (1634), which were also purchased by Volf Engelbert Auersperg. In one of his books offered in Ljubljana, Sennert's discussion of heat was bound to Sennert's Letters; in the second reprint, however, no such binding took place. The Škofja Loka Capuchins acquired the earlier publication of Sennert from the year 1611. Sennert described nature, as well as the branches of medical sciences.⁶⁵²

The Škofja Loka Capuchins loved to read the books of writers from their otherwise opposite Jesuit order; they bought a book of Jesuit Schott, who first described Guericke's vacuum experiments while using Guericke's pump. In the Škofja Loka Monastery they read a philosophical course with physics of Capuchin of the Swiss province, Gervais Brisacensis. After his logic, Gervais also dealt with general physics with a special emphasis on vacuum experiments with the mercury barometer of Capuchin Valeriano Magni. He apparently attributed to his colleague Magni even the Torricellian experiment, as he did not even mention the poor Torricelli.⁶⁵³

⁶⁵¹ Grdenić, 2007, 366, 397-399, 410.

⁶⁵² Sennert, 1664, 127; Jakob Barner, *Prodromus Sennerti novi, seu Delineatio novi medicinae systematis, in quo quicquid a primis seculis in hunc usque diem de arte prodiit, Hippocratis, Galeni, Paracelsi, Helmontii, Sylvii, Willisii, &c. dogmata, ex principiis anatomico-chymicis examinantur*. Augustae Vindelicorum: Theophili Göbelii & Johannis Schönigkii, 1674; Jacobi Barneri *D. Spiritus vini sine acido, hoc est: In spiritu vini & oleis indistinctè non esse acidum, nec ea propterea à spiritu urinae reverà coagulari, demonstratio curiosa: cum modo conficiendi salia volatilia oleosa, eorumque usu*. Lipsiae: Johannis Fritzschi & Joh. Erii Hahnii, 1675 (Seminary Library of Ljubljana)

⁶⁵³ Brisacensis, 1699, 3: 34/35.

⁶⁴⁷ Dolar, 1993, 47.

⁶⁴⁸ Bahor, 2005, 397-398, 679, 681; Jan, 2000, 3.

⁶⁴⁹ Benedik, 1994, 213.

⁶⁵⁰ Note of Marta Gartner, the librarian of Capuchin library in Škofja Loka.

Table 6-10: Maribor and Kranj Capuchins' monastery books of natural sciences distributed after year of their print⁶⁵⁴

Writer	Title	Year, Language
Gervais Brisacensis	Cursus Philosophicae	1699 L (NUK-4615; year 1711 NUK-4956) (KSMA)
Hübner, Johann (* 1668; † 1731)	Curieuses und Reales Natur-Kunst-Berg-Gewerck-und Handlungs-Lexicon, Darinnen nicht nur Die in der Philosophie, Physic, Medizin, Botanic, Chymie, Anatomie, Chirurgie und Apothecer-Kunst, wie auch in der Mathematic, Astronomie, Mechanic, burglschen und Kriegs-Baukunst, Schifffahrten... sondern auch alle in Handel und Wandel, ingleichen im Jure und vor Gerichten vorfallende und aus allerhand Sprachen genommene, unentbehrliche Wörter, der gelehrten und ungelehrten zu sonderbaren nutzen gründlich und deutlich erkläret; als einen anderen Theil des Realen Staats-Conversations- und Zeitungs-Lexici mit großen Vortheile gebrauchen/nebst einer ausführlichen Vorrede Johann Hübners. Hamburg	1714 N (KSMA) (NUK-6592 Leipzig 1734 Peer's Bookplate; NUK-2487 year 1711; NUK-2493 year 1709; NUK-2485 year 1732)
O'Kelly de Aghrim, Sir William	D: O Kelly Guilelmi philos doct. J.u. Licentiati Philosophia Aulica Juxta veterum ac recentiorum philosophorum placita. Compendiose, ac methodo parisiensi pertractata, et illustrioribus superioris aevi inventis, et experimentis illustrata, et quatour in partes, amputata prolixitate, divisa. In gratiam studiosae nobilitatis, aut vulgarem philosophiam fastidientis, aut scholarum taedium non ferentis, aut denique rerum curiosarum avidae. Pars I Ex praenotionibus, & logica. 2. Ex ethica. II. Ex physica. III. Ex metaphysica, & interprete. Neo-Pragae: Hampoelan, Joan Georg Hofeaker	1701 (KSSKL-Kranj V 45, KSSKL-Loka S 12)

Table 6-11: The vacuum-related literature of the Škofja Loka and Kranj Capuchins, which Joahim assigned to the philosophy with physics in his catalogue of 1740-1753

Writer	Title	Year	Language
Magnus, Albertus	Divi Alberti Magni phisicor(um) (KSSKL-Loka S 3). Libri 9	1494	L
Schott, Kaspar	Cursus mathematicus, sive absoluta omnium mathematicarum. Herbipoli: Schönwetter (S). Reprint: 1674. Francoforti: Cholin; 1699. Cursus mathematicus, sive absoluta omnium mathematicarum. Francoforti: Moen (NUK-4217; KSSKL-Loka T 1) 1699	1699, 1661	L
Zahn, Joannes (* 1633; † 1707).	Specula physico mathematica-historica notabili al mirabili scientiorum in qua mundi mirabilis aconomia, non-mirifice amplus, et magnificus ... 1-2. Norimbergae: Lochner (NUK-8462; KSSKL-Loka S 27).	1696	L
Gervais Brisacensis (* 1648 Breisach; OFMCap; † 1717)	Cursus Philosophicae brevi et clara methodo in tres tomules distributus; auctore P.F. Gervasio Brisacensi, Ordinis fratrum minorum Capucinatorum Provinciae Helveticae. Tomulus primus, Logica. Tomulus secundus octo libros Physicorum, seu Physicam universal. Tomulus tertius, complectens libros de coelo, de generat., De meteoris, de animae, seu Physicam particularem et Metaphysicam). Coloniae Agrippina (Cologne): Joan Schlebusch	1699	L

⁶⁵⁴ Škafar, 1993, 87-91.

	(NUK-4615; KSSKL-Loka S 13-15, Kranj)		
Reinzer, Francisco (Reinitzer, SJ)	Meteorologia philosophico-politics, and duodecimal dissertations for quaestiones meteorologicas and conclusions of political divisions, appositisque symbolis illustrata. Augustae Vindelicorum: Wolf (NUK-8357, KSSKL-Loka S 2, 3)	1709	L
Semery, Andreas (* 1630; SJ; † 1717)	Triennium Philosophicum quod P. Andreas Semery Remus e Societate Jesu in Collegio Romano Philosophiae iterum Professor Detabat Qu. Ac Editione ab Authori Recognitum & Auctum. Annus Secundus. Venetiis (KSSKL-Loka S 25)	1690, 1708?	L
Rentz, Placid (Renz, * 1692 Stetten am Kalten Markt in Baden-Württemberg; OSB; † 1748 Kloster Hofen (Friedrichshafen))	Philosophia ad mentem Angelici Doctoris Divi Thomae Aquinas – Logica, Ejusdem Physica Universalis, Ejusdem Metaphysica... Tomus II. Complectens physicam universalem. Weingarten: Herckner, 1714 (KSSKL-Loka previously in Kranj; NUK-5144). Reprint: Köln, 1723 (KSSKL-Kranj Z 81-83, KSSKL-Loka S 1-3)	1714, 1723	L
Jaslinszky, András (Andrea Jaslinszki, * 1715 Szinna; SJ 1733 Košice; † 1784 Rozsnyó)	SJ Institutiones Physicae. Tyrnavia (NUK-8497; KSSKL-Loka T 4; FSLJ-2 g 42)	1756, 1761	L
Khell	Physica ex recentiorum observationibus accommodata. 1-2. Vienna: Trattner (KSSKL-Kranj V 29, KSSKL-Loka T 2-3; NUK-8206).	1751, 1754/55	L
Joseph Kraus (* 9. 11. 1678 Neumarkt; SJ; † 16. 11. 1718 Osijek)	Consolatio Geographiae in solatium desolatae mathesis et discipulorum per modum recreation automnalis instituta et proposita a rev. D. Carolo Rodhe, Sacri exemptique ordinis Cisterciens. Celeberrimi Monasteries ad Fontes Marianos professo, praeside R. P. Josepho Kraus and Societate Jesu. Edita and examine publico ipso praeside. Ljubljana: Mayr (KSSKL-Kranj W 88, also in Erberg's library bought for NMLJ).	1717	L

Table 6-12: The study of vacuum-related medical publications in the Škofja Loka Capuchin collection.

Writer	Title	Year	Language
Lower, Richard	Englischen Artzney-Büchlein	1738	German
Johann Joachim Becher (* 1635 Speyer; † 1682 London).	Kluger Haus-Vater, Verständige Haus-Mutter, Vollkommener Land-Medicus, Wie auch Wohlerfahrner Roß-und Viehe-Artzt : Nebenst einem Deutlichen und gewissen Hand-Griff, Die Haushaltungs-Kunst Innerhalb 24 Stunden zu erlernen ... Welchem anitzo noch beygefüget des edlen Weidmanns geheimes Jäger-Cabinet wie auch einige nützliche und nöthige Rechts-und andere Formularien (Clever House-Father, Understanding House-Mother, Perfect Land-Medicus, As Well Welfare Horse and Cattle-Doctor: ... attached to the noble Weidmann's secret hunter's cabin as well as some useful and necessary legal and other forms, KSSKL-Loka Y 10)	1721	German
Paracelsus	Dess Fürsten aller Artzeten Aureoli Paracelsi Tractat	1563	German

6.4.1.4 Books on Vacuum Classified as Medical Science in Škofja Loka Capuchin's Library

In 1717 the Škofja Loka Capuchins acquired the reports on Lower's research in London. As the first, Lower introduced blood transfusions among the Westerners; he collaborated with Robert Hooke, the manufacturer of Boyle's Vacuum Pumps. The Škofja Loka Capuchins also read Paracelsus and the predecessor of Stahl's theory of phlogiston combustion, Becher. Latter, Becher became a commercial councilor in Vienna in 1666, which heightened the popularity of his work in Habsburg Monarchy.

6.4.1.5 Franciscans for Ljubljana Jesuits: North Italian Brixianus and his Local Critic Markilič

The examples of Capuchin vacuum researcher Magni were soon followed by researchers from other branches of the Franciscan Order. The experimental textbook about physics of the Friar Minor Conventual (Minorite) monk from Brescia (Brixianus) was acquired by the Ljubljana Augustinians. B.F. Erberg (1751) bought Brixianus's mathematical textbook in four parts (1738, 1739) including his presentations of surfaces of revolution for the Jesuit library of Ljubljana as one of the manuals needed for updating the instruction according to the instructions of the emperor Empress Maria Theresa. The Franciscans of Novo Mesto (New City) had both parts of their Friar Minor Conventual (Minorite) co-brother Brixianus' book, the physical part even in two different editions according to the old good Lower Carniola (Dolenjska) principle of the "similar supports the similar".

The Friar Minor Conventual (Minorite) Fortunatus Brixianus (Brixia, Brixanus, Girolamo Ferrari, *1701 Brescia; 1718 OFMConv Borno by Brescia; † 1754 Madrid) was a professor of natural science with mathematics in his native city of Brescia, after which he assumed his own pen name. In 1738 and 1748 he was in Venezia and Padua and in 1744 and 1750 he was in Rome where he picked up some influences of the Jesuit G.B. Tolomei. However, the progressive acquisition of Newtonian physics did not make Fortunatus Brixianus a true

epistemological follower of his model; while he was abandoning the Cartesian physics during his travels, he never abandoned the strict mechanistic assumptions, so he always refused to consider the "accurate measurements supporting of Newtonian formulas as evidence of the physical reality of universal gravitational attraction", which deprived Fortunatus Brixianus of Bošković's eventual support. Fortunatus Brixianus even developed some aspects of history of mathematics from the ideas of Ramus' *Historia Mathematica*, and the books of the Jesuits Millet de Chales (Dechales), Aimé Varcin (1630-1702) as well as the famous Ch. Wolff. In 1753 Fortunatus Brixianus became a secretary of the general of Franciscan order Pedro Juanete de Molina (1698 Onil in the Spanish province of Alicante south of Valencia-1775 Vila-Real in Northern Portugal) who soon departed from Rome to Madrid.

Fortunatus Brixianus advocated the modernized slightly Newtonian ideas of the Franciscan Duns Scotus, atomism, and strict adherence to mechanics as the foundation of natural science. In the experimental and mathematical textbook, he did not recognize the scientific authority of the church or Aristotle, and the validity of the Brixianus textbook about physics was confirmed by scholars in Venetian academic center of Padua on 20 September 1745. The Augustinians of Ljubljana used the edition of Fortunatus Brixianus's work published in 1751 and 1752; it consisted of two books on general and one on special physics especially focused on astronomy with chronology. Later, those books were given to the Ljubljana Lyceum library, where part of the leaves remained uncut until the end of the 1990s. It seems that Brixianus did not have any special readers among Ljubljana's Augustinians? Two and a half century after its printing the writer of these lines took over that unread book in NUK, as it had apparently not caused excessive interest in the white capital of Ljubljana.

Brixianus has addressed many contemporary researchers, including Gassendi with his vacuum in the pores⁶⁵⁵ connected with Du Hamel's preservation of vacuum, and the Cartesian Le Grand with his *Institutio Philosophiae* which also belonged to Ljubljana Franciscan library and to Valvasor's library as it was on sale in Mayr's office in Ljubljana. In his book *De Meteoris* Jean

⁶⁵⁵ Brixianus, 1751, 1: 52.

Baptiste du Hamel has tried to combine Scholastic approach with Descartes's innovations.⁶⁵⁶ Brixianus noted his neighbor Jesuit Lana Terzi of Brescia,⁶⁵⁷ 'sGravesande, Musschenbroek⁶⁵⁸ and Boerhaave. Two Le Grand's published supports of Descartes were put on the Papal index together with several Descartes' books. Le Grand favored the intermediate direct contact of bodies and used Descartes' example of emptied glass to refute the vacuum. Le Grand highlighted the remains of the water in an empty jar so he could deny the vacuum.⁶⁵⁹ Le Grand noted the pneumatic experiments, mostly those of Gassendi with the salt in allegedly differently shaped atoms, and the experiments with the Aeolian Harp.⁶⁶⁰ Le Grand used Gassendi's explanation of Torricellian experiments of barometer with the notes on the evident translation of heat and light in the vacuum.⁶⁶¹

Brixianus researched natural phenomena with experiments without specifically considering Aristotle's opinion or theologians.⁶⁶² He did not describe Torricelli's experiments⁶⁶³ in a large section on the vacuum, although he acknowledged the existence of a vacuum and endorsed a tremendous amount of evidence from Torricelli's Florentine Accademia del Cimento to distinguish between heat and cold-producing substances.⁶⁶⁴ Among the Newton's critics, he quoted the Italian Venetian translation of *Lezioni di Fisica* (1743). The author was an honorary member of the Parisian Academy (1721) and a member of the London Royal Society (1729) Joseph Privat de Molières (1734-1739).⁶⁶⁵ Molières based his book on his own lectures at Royal College and tried to mix Newtonian theory with small Cartesian vortices of Malebranche.

At the end of the first of his books about general physics, Brixianus recommended the Newton's *Principles* in the edition of Roman Friars Minims Bošković's later collaborators Thomæ Le Seur (Leseur, B. 1703 Rethel; OM; D. 1770 Rome) and

Francisco Jacquier (B. 1711 Vitry-le-François; OM; D. 1788 Rome) published in 1739, Samuel Clarke's Newtonian optics also available in the library of Franciscans in Novo Mesto (1741), Musschenbroek's translation of the reports of experiments of Accademia del Cimento (1731), the Venetian edition of Boerhaave's *Chemistry* (1737) and some medical writings. The recommendation fell to the fertile ground, as the Franciscans of Novo Mesto (New City) besides Brixianus, obtained an edition of Friars Minims of Newton's *Principles* and one of Musschenbroek's works. Likewise, the Franciscans of Ljubljana read Musschenbroek's books and Jacquier's textbook with its 3rd - 6th parts focused on mathematics, general physics, experimental physics and ethics. By funny coincidence the Friars Minor Conventual of Ptuj obtained from their religious co-brothers of Graz the first two parts of Jacquier's textbook about logics and metaphysics in Graz edition which the Ljubljana Franciscans missed in Jacquier's textbook published in Venetia by Simon Occhi in 1762.⁶⁶⁶

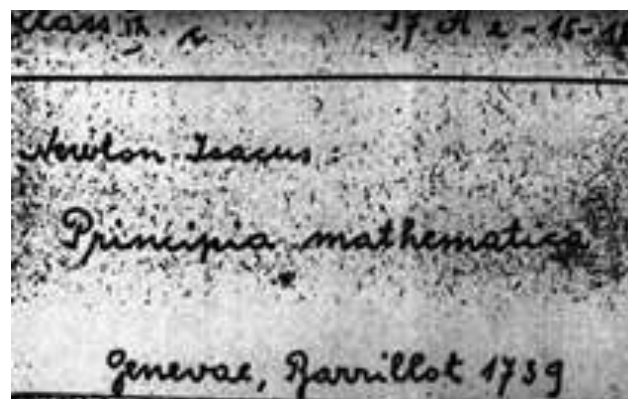

Figure 6-21: Toš's catalog of Newton's *Principles* (1739) in the Novo Mesto (New City) Library Catalog of 1942.

Brixianus began his first book with formations-creations of the bodies and appearances of bodies according to natural principles; Brixianus divided his second book into chapters on the source of gravity,⁶⁶⁷ artificial and natural gravitational movement,⁶⁶⁸ and especially the gravitational movement of fluids with a special emphasis on hydrostatics.⁶⁶⁹ Brixianus devoted the penultimate

⁶⁵⁶ Martin, 2011, 149.

⁶⁵⁷ Brixianus, 1751, 1: 250, 260.

⁶⁵⁸ Brixianus, 1751, 1: 260, 277.

⁶⁵⁹ Benedict XIV, 1758, 51, 126; Le Grand, 1679, 335-336.

⁶⁶⁰ Le Grand, 1678, 10-13.

⁶⁶¹ Le Grand, *ibidem*, 15-16.

⁶⁶² Sodnik-Zupanec, 1943, 24; Lind, 1992, 73, 374.

⁶⁶³ Brixianus, 1751, 1: 50-56, 244-262.

⁶⁶⁴ Brixianus, 1751, 1: 278.

⁶⁶⁵ Brixianus, 1751, 1: 56.

⁶⁶⁶ F. Jacquier, *Institutiones Philosophicae*, Venetiis: Simonis Occhi, 1762.

⁶⁶⁷ Brixianus, 1751, 2: 1-29.

⁶⁶⁸ Brixianus, 1751, 2: 30-231.

⁶⁶⁹ Brixianus, 1751, 2: 323, 325, 330, 332-333, figures 15 and 19 on table XII.

chapter of his second book to the suspension of mercury in Torricellian pipes. He described Boyle's criticism of the Jesuit Francis Linus (Hall), before explaining Musschenbroek and Pascal's experiments. He was also aware of the merits of Huygens, of Newton's assistant Samuel Clarke and of a Minim (Paulanerorden) monk Emmanuel Maignan.⁶⁷⁰ Brixianus compared the measurements of the densities of air of dozen researchers in Musschenbroek's table commentary of Florentine academic merits.⁶⁷¹ Brixianus finished his second book with sketches of motion, slopes, collisions, communicating vessels, vacuum barometers and thermometers.



Figure 6-22: Le Grand's (1679) painting on the title page of his book in Franciscan Library of Ljubljana (noted as F).

Brixianus divided the last third book of special physics into six dissertations about the creation of the world, the mathematical description of the Earth, the system of the universe, the special useful features of stars and chronology. He published two copperplates of the Copernican system separated by the copperplate of Tycho's universe;⁶⁷² the obsolete Ptolemaic doctrine has been obviously already turned away into the old nonsense. With the last nineteenth group of images, he explained

⁶⁷⁰ Brixianus, 1751, 2: 232.

⁶⁷¹ Brixianus, 1751, 1: 338.

⁶⁷² Brixianus, 1752, 3: table XVI-XVIII.

the solar eclipse. He used Newtonian teachings in both mechanics and optics.⁶⁷³

The curator of the library of the Franciscans and several times guardian Hieronim Markilič (* 1712; OFMobs; † 24. 5. 1790 Ljubljana) was among the fiercest sharpest critics of his own elder religious co-brother Fortunatus Brixianus (a Brixia, Brixanus, Girolamo Ferrari, * 1701 Brescia; OFMobs; † 1754) and other modern researchers.⁶⁷⁴ In 1764 in Ljubljana, Markilič acquired eleven years old Scholastic Regensburg Philosophy of Benedictine from Prüfening Abbey (Prifling) monastery on the outskirts of Regensburg in Bavaria Veremundus Gufl (* 1705; OSB; † 1761) with a detailed description and sketch of Pascal's experiment⁶⁷⁵ and Schott's explanation of work of Guericke's pumps.⁶⁷⁶ Gufl made dozens of experiments. In 1769 the Franciscan H. Markilich (Markilič) rejected his assumptions together with the opinions of Fortunatus Brixianus (of Brescia).⁶⁷⁷



Figure 6-23: Le Grand's picture of artificial water fountain under the pressure of the air (Le Grand, 1679, 624); kept in Ljubljana Franciscan Library (F).

⁶⁷³ Brixianus, 1751, 1: 53, 56, 247.

⁶⁷⁴ Markilich (Markilič), Hieronymus. Contra P. Fortunatum a Brixia et alios recentiores in: 1769. Theologia Dogmatica, volume 4 pp. 306/307 (FSLJ-12 c 4-7); Furlan, 1926, 38.

⁶⁷⁵ Gufl, 1753, 102.

⁶⁷⁶ Gufl, 1753, 103, Fig. 8 tab 1; 117.

⁶⁷⁷ Markilich (Markilič), 1769-1774, 4: 377.

In 1777, Markilič used the 18-year-old Zagreb-based tract of imprecision of philosophy, published by the professor of physics in Ljubljana, Jožef Matija Engstler. It was translated by Kazimir Bedeković. Bedeković translated into Latin the Reflections upon learning of Thomas Baker which was published anonymously in 1709/10 and posthumously in London in 1756. At the same time the translation was also published in Zagreb bound with their local examining thesis by the same printer Härl. Bedeković was born near Varaždin and studied philosophy in Vienna in 1758. He taught physics in Zagreb.⁶⁷⁸ Baker's ideas enabled numerous translations by which many thinkers profited, including Engstler and Bedeković: they initially published only one page of the unpagged welcome introduction. Baker devoted his seventh and eighth chapters to physics and astronomy.⁶⁷⁹

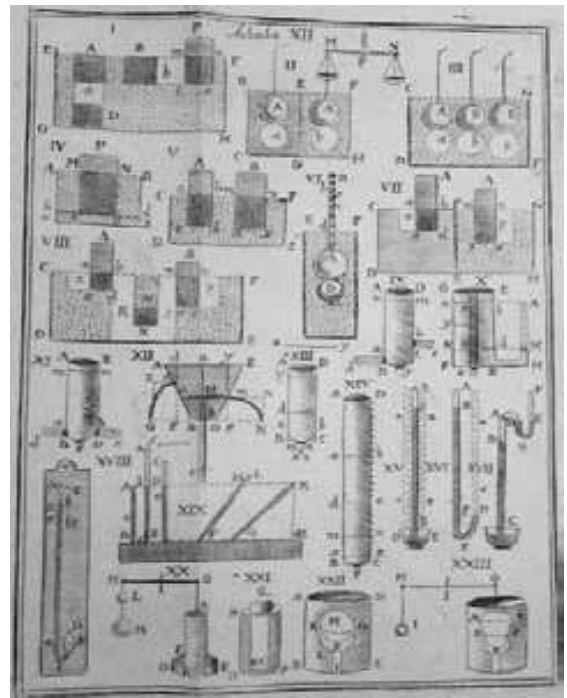

Figure 6-25: Brixianus's vacuum barometers at Ljubljana Franciscans' library (Brixianus, 1751, Figures 15 and 17 in Table XII); F.



Figure 6-24: Le Grand's sketch of Descartes vortexes around a magnet in Franciscan Library of Ljubljana (Le Grand, 1679, 599); F.

The Englishman Baker criticized Descartes and defended the modern theory of vacuum and molecules advanced by the Minim monk Mersenne and the Jesuitical classicist literary critic and opponent of Jansenism René Rapin's (1612-1687) *Reflexions sur la Poétique d'Aristotle*. Baker also supported the Parisian Jesuit superior Gabriel Daniel (1649-1728) who criticized Descartes's vortices in 1690 and additionally refused Pascal's Jansenism four years later.⁶⁸⁰ In fact, Baker was

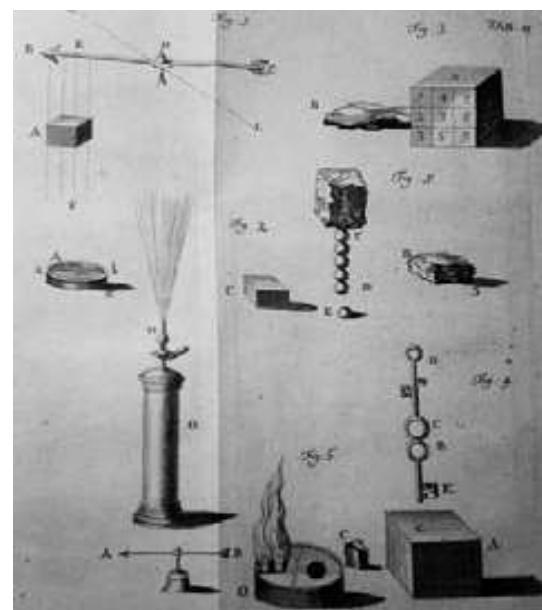

Figure 6-26: Magnetic experiments with overpressure and vacuum in Erberg's Ljubljana edition of Musschenbroek in Ljubljana Franciscans' library (Musschenbroek, 1754, tab 2); F.

⁶⁷⁸ Bazala, 1978, 250-251.

⁶⁷⁹ Baker, Engesler, Bedeković, 1759, 59-70-81.

⁶⁸⁰ Baker, Engesler, Bedeković, 1759, 64-65; Gabriel Daniel, *Voyage du monde de Descartes*, 1690, Translated as : *Iter per*

mundum Cartesii: novae difficultates a peripatetico propositae auctori itineris per mundum Cartesii circa cognitionem brutorum. Cum refutatione duplicis defensionis systematis mundi Cartesii, 1694. Reprint: Ignatius Koller (Choler, 1684-1750) Vienna, 1720; Gabriel Daniel, *Entretiens de Cléanthe et d'Eudoxe sur les Lettres au provincial*, 1694).

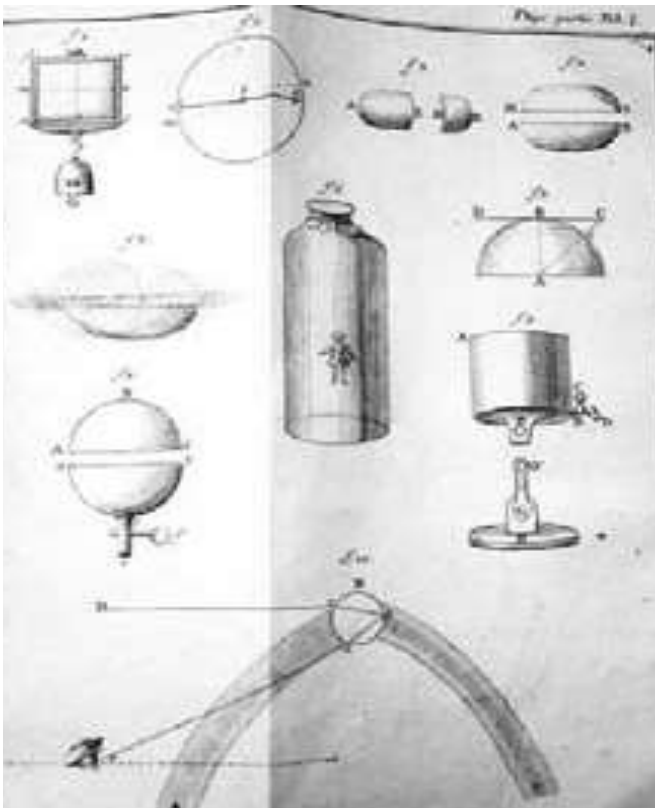

Figure 6-27: Magdeburg vacuum hemispheres from Philosophy at the Franciscan Library (Gulf, 1753, 110); F.

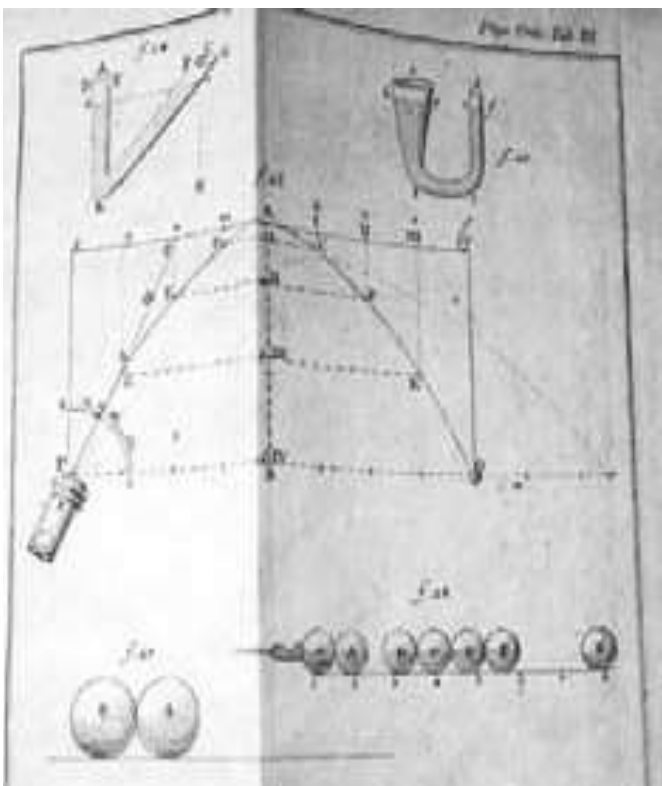

Figure 6-28: Communicating vessels and ballistic parable from Gulf's Philosophy at the Franciscan Library (Gulf, 1753, 9); F.

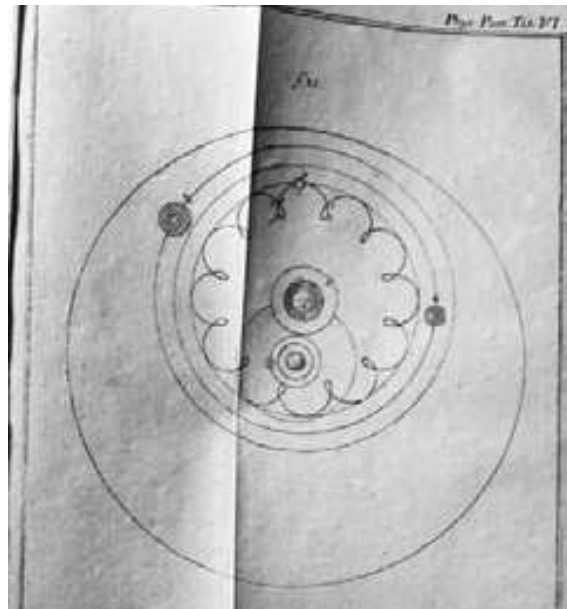

Figure 6-29: The Solar system from Gulf's Philosophy at the Franciscan Library (Gulf, 1753, 200); F.

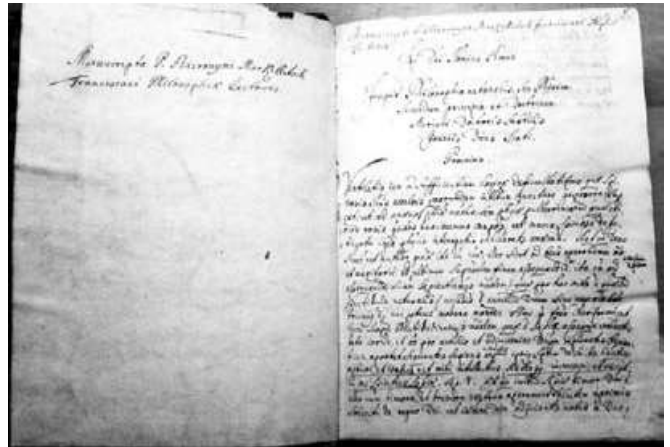

Figure 6-30: The title page of Markilič's Franciscan Philosophy with a discussion of the vacuum (Markilič, 1755, 1); F.



Figure 6-31: Markilič's Franciscan Philosophy of Vacuum (Markilič, 1755, 775); F.

also acquainted with the achievements of Chinese astronomers. Baker praised Copernicus' theories⁶⁸¹ which right then also got some momentum in Slovenian Catholic countries.



Figure 6-32: Markilič's later insertion of one half page in his book against the vacuum theory of Fortunatus from Brescia (Brixianus) (Markilič, 1769-1774, 306/397); F.



Figure 6-33: Hieber's sketch of the equilibrium in a liquid as an introduction to the description of vacuum pumps (Hieber, 1797, 66); F

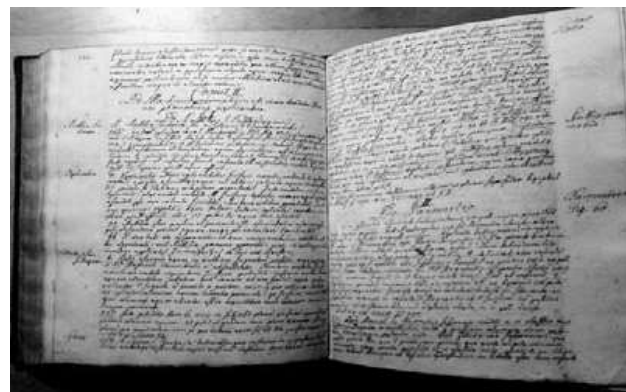

Figure 6-34: Hieber's description of vacuum pumps and barometers (Hieber, 1797, 66); F.

6.4.2 Franciscans for Ljubljana Jesuits: North Italian Pace

Despite the long-standing disputes, Ljubljana Franciscans read many Jesuit books and the Jesuits in Ljubljana read many of the Franciscan writers. Among the most popular on both warring sites was Franciscan Stefano Pace with his Italian written Physics of Peripatetics, Cartesians and Atomists. In his own way, he was in love with the two groups of monks, as he was the Jesuit in Parma until God's caution seduced him in Franciscan habit. In the first two parts of Pace's work, the Jesuits of Ljubljana entered their bookplate in 1771, thirty years after the printing of that book; during this time, the Franciscan poet and teacher Valentin Vodnik almost certainly learned about Pace's ideas.

Pace was initially the Jesuit in Parma, but in 1697 he joined Franciscan order. He borrowed up his physics' ideas from the Jesuit Paul Casati, but Pace used to teach philosophy more than mathematics.⁶⁸² Pace described the individual phenomena (light, frost, heat, electricity) in a series of events, and he quoted Cartesians, atomists, old scholastics, and new peripatetic; among the latter, he most likely considered himself, since he always cited the peripatetic beliefs as the last. Pace began his first part with a praise of Roemer's measurement of the speed of light as the achievement of the "second Tycho", probably because both were Danes.⁶⁸³ Pace noted the description of the Glauber's⁶⁸⁴ cold and salt, the air pressure with a vacuum and Torricellian

⁶⁸² U. Baldini, *L' Insegnamento Fisico-Matematico*, Padua 2005.

⁶⁸³ Pace, 1741, 1: 190.

⁶⁸⁴ Pace, 1741, 1: 263.

⁶⁸¹ Baker, Engesler, Bedeković, 1759, 71-72.

experiment.⁶⁸⁵ Pace continued with Boyle's achievements,⁶⁸⁶ the Bologna stone,⁶⁸⁷ and the description of Cartesian assumptions of Jacques Rohault (* 1620; † 1675).⁶⁸⁸ Pace mentioned Gassendi,⁶⁸⁹ but not Newton. Pace's 18th Chapter of Tractate II of the first part discussed the vacuum experiments while in his last 19th chapter Pace narrated on the movement in the empty.⁶⁹⁰ He quoted Aristotle and his peripatetic fans,⁶⁹¹ and also Pace's neighbor, the Jesuit Lana Terzi. The first part was completed with Pace's sketches of reflection and refraction of light, hydraulic paradox and vacuum experiments, even the famous Huygens' experiment of vacuum in vacuum, which Pace ascribed to Gilles de Roberval (* 1602; d. 1675).⁶⁹² Pace dedicated his last book to biological sciences.

In the six tracts of the second book, Pace described the substance in stars,⁶⁹³ comets,⁶⁹⁴ astrology for decision-making,⁶⁹⁵ individual planets,⁶⁹⁶ tides,⁶⁹⁷ transformations of metals,⁶⁹⁸ and finally underground waters and earthquakes.⁶⁹⁹ The images inserted at the end of the text presented all the possible systems of the world, the eclipses, the refraction of light and magnets.

6.4.3 *Franciscan Library in Novo Mesto*

The Novo Mesto Franciscans also used Jesuits' works as well as the books of Augustinians. Among most important Novo Mesto works from Augustinian networks was the book of the son of a Bavarian shoemaker Maximus von Imhof (* 1758; † 1817), who taught mathematics and philosophy between 1786-1791 at the Munich Monastic School. In 1790, he became a member and ten years later the director of the physical class of the Munich Academy. In 1790 he was a professor of

⁶⁸⁵ Pace, 1741, 1: 218-233.

⁶⁸⁶ Pace, 1741, 1: 237.

⁶⁸⁷ Pace, 1741, 1: 291.

⁶⁸⁸ Pace, 1741, 1: 311.

⁶⁸⁹ Pace, 1741, 1: 289.

⁶⁹⁰ Pace, *ibidem*, 1:241-258.

⁶⁹¹ Pace, *ibidem*, 1: 184.

⁶⁹² S. Pace, *La fisica dei Peripatetici*, Vicenzia 1718, 1: 238, Fig. XIII.

⁶⁹³ Pace, 1741, 2: 90.

⁶⁹⁴ Pace, 1741, 2: 141.

⁶⁹⁵ Pace, 1741, 2: 155, 158.

⁶⁹⁶ Pace, 1741, 2: 149-153.

⁶⁹⁷ Pace, 1741, 2: 177.

⁶⁹⁸ Pace, 1741, 2: 360.

⁶⁹⁹ Pace, 1741, 2: 388, 295. Correct titles are in parenthesis

physics and mathematics in the prince-elector's Lyceum. For two decades, he led the installation of lightning rods in Bavaria and described them in several books, which made his work likewise important as the achievements of Biwald, Ambshell or Giuseppe Toaldo's (1719-1797) introductions of Central European lightning rods networks south of Imhof's Bavaria.

The Augustinian monk Maximus Imhof was a full-time professor of physics, mathematics and economics in the Munich lyceum, as stated in his Latin textbook *Institution physicae* (1797). He cited Boyle and Hauksbee's vacuum experiments⁷⁰⁰ considering both the attractive force and the repulsive forces.⁷⁰¹ He reported in detail about Lavoisier's and Crawford's theory of combustion against phlogiston with the discovery of phosphorus included;⁷⁰² as well as the dispute over the electricity of Nollet and Symmer against Franklin.⁷⁰³ Despite of his notes about Franklin, 'sGravesande and Musschenbroek, Imhof avoided any mention of Bošković.

Zinsmeister liked the pioneer of the Bavarian lighting rods Maximus von Imhof who was probably Zinsmeister's teacher besides Hiebel when Imhof replaced Epp as the full professor of physics, mathematics, and economy in Munich Lyceum after the year 1790. It is very likely that Zinsmeister himself brought the textbook of his Bavarian compatriot Imhof to the Novo Mesto Franciscans' Library. Imhof was among the rare authors whom Zinsmeister cited in his manuscript, although just in the later additions in the margins of his work. Zinsmeister admired Imhof's explanation of the impenetrability of matter which caused the reflection of light. Imhof certainly discussed vacuum experiments considering the attractive and repulsive forces,⁷⁰⁴ but he didn't mention Bošković.

Indeed, even the Novo Mesto Franciscans followed the phlogiston fan Stahl's ideas that prevailed until Lavoisier's days; so, the Novo Mesto (New Town) Franciscans bought at least four Stahl's books and

⁷⁰⁰ Imhof, 1797, 24, 174.

⁷⁰¹ Imhof, 1797, 36.

⁷⁰² Imhof, 1797, 108, 158-159, 168.

⁷⁰³ Imhof, 1797, 264.

⁷⁰⁴ Maximus Imhof, *Institutiones physicae*. Monachii:

Lentner, 1797 (Franciscans' Library of Novo Mesto), pp. 24, 36, 174.

Table 6-13: Vacuum-related Books of Franciscan library in Novo Mesto in Carniola.⁷⁰⁵ Books on vacuum and similar techniques from Cartesian textbooks to the first Carniola-based professional works dealing with the vacuum

Writer	title, place: publisher	Year	Language
Schwenter, Daniel	Mathematik und Physik. Nürnberg	1651	N (for German)
Majolo, Simone, born in Asti in Piemonte, Bishop of Vulturara e Montecorvino in southeast Italy until his death in 1597	Colloquia physica nova. Vulturara	1654	L
Boyle, Robert	<i>Opera omnia</i> . Venetiis: Hertz	1696	L
Wolff, Christian	Mathematischen Wissenschaften. Frankfurt: Renger	1701	N
Wolff, Christian	Wirkungen der Natur = Physica. Halle: Renger	1746	N
Descartes	Physica et metaphysica. Amstelodami: Blaeu	1704	N
Tarvisini (Giacomo Placentini, * 1672; † 1762)	De barometro dissertationes duae Jacobi Placentini d. Tarvisini: quarum prima continent examen hypothesis D.G. Christoph: Schelhameri, altera interpretatione Leibintian(a)e: adiectis aliis circa motus barometri coniecturis. Patavii: Conzatti.	1711	L
Stahl, Georg Ernst	Experimenta, observationes, aniniadversiones... chymicae et physicae. Berolini: Hande	1731	L
Stahl, Georg Ernst	Opusculum chymico physicum. Halle	1715	L
Stahl, Georg Ernst	<i>Collegium practicum</i> . Nürnberg (German Translation: Storch, Johann alias Pelargus, Hudericus. Leipzig)	1729, 1745	L N
Newton, Isaac	Principia Mathematica. Genevae: Barrillot	1739	L
Keill, John	<i>Physica et astronomia Vol 1</i> . Mediolani: Aonelli (NUK-7919 has the edition Institutones astronomiques printed in 1746)	1742	L
Musschenbroek	Elementa physicae. Vol 1. Venetiis: Recurti	1745	L
Brixianus, Fortunatus OFM	Philosophia... Mechanica III Vol 3. Brixiae: Rizzardi	1745- 1747	L
Brixianus, Fortunatus	Philosophia... Mechanica II parts. Vol 1. Brixiae: Rizzardi	1751- 1752	L
Biwald, Leopold SJ	De Studii physici natura vol. 1. Graecii: Widmanstad	1767	L
Biwald, Leopold	Institutiones physicae. Vol. 1. Graecii: Lechner	1774	L
Zallinger, Joann Batista (* 1731; SJ; † 1785)	De viribus materiae Dissertatio physica. Graecii: Widmanstad... Propugnaret Jos. Liber baron de Sternbach. Oeniponti.	1771	L
Horváth	Physica generalis et particularis. Augustae: Rieger	1775	L
Ambshell, Anton	Dissertatio de mundo in genere. Labaci	1780	L
Imhof, Maximus	Institutiones physicae. Monachii: Lentner	1798	L
Neumann, Johan Philip	Compendiaria Physica. Graecii: Ferstl	1808	N
Moret, Théodore	Tractatus physico-mathematicus de aestu maris. Viennae: Voigt	1719	L
Breckerfeld, Franc	De horologia solaris et fixa. Graecii:	1726	L

⁷⁰⁵ The correct titles are in parenthesis.

	Widmanstad		
Lechner, Johan Baptist	De arte Arithmeticae (Facilima artis arithmeticae methodus: das ist: Sehr leichter Unterricht und Lehr-Art der höchst-nothwendigen und nutzbarsten Rechen-Kunst). Augsburg: Wolff	1733	L
Hoffmann, Friedrich	<i>Dissertationes physico-medico-chymica.</i> Venetiis: Balleon (FSNM; FSLJ-5 b 43, FSLJ-5 b 46. FSLJ-12 b 26 has editions of 1737-1741).	1737, 1738, 1732?	
Lanzoni, Joseph (* 1663; † 1738)	Opera omnia medico-physica et philologica. Lausane: Bosquet	1738	
Hederich, Benjamin (1675; † 1748)	Mathematische Wissenschaften (M. Benjamin Hederichs rect. Schol. Hayn. Anleitung zu den fürnehmsten Mathematische Wissenschaften: benanntlich der Arithmetica, Geometrie, Architectura militari, Architectura civili, der Astronomie und Gnomonica, so fern solche einem politen Menschen, insonferheit aber denen, so die Studia zu prosequiren Gedencken, nützlich und nöthig. Wittenberg: Samuel Gottfried Zimmerman.	1744	N
Redlhamer, Joseph SJ	<i>Physica generalis.</i> Viennae: Trattner	1754	
	<i>Abhandlungen med.-chym.-chir.-anatomica-botanica.</i> Kays. Natur. Akadem. Nürnberg. Nürnberg (Kaiserlich-Leopoldinisch-Carolinische Deutsche Akademie der Naturforscher)	1757- 1762	
Desing, Anselm	Replica Pro Clarissimo viro Abrahamo Gotthelf Kaestnero Matth. P.P.E. Acadd. Regg. Sc. Suec. & Pruss. Institut. Bonon. Sac. Reg. Sc. Gott. Membro, Super Methodo Wolffiana scientifica aut mathematica. Augustae: Gastl	1754	L
Weibl, Castul OFM	Physica generalis. II Vol. 1. Manuscript	1772	L
Weibl, Castul OFM	Physica particularis. II Vol. 1. Manuscript	1772?	L
	Arithmetica et geometria. Vindobonae: Trattner	1780	L
(Chappe, Claude)	Beschreibung des Telegraphen. Wien	1795	N

Table 6-14: Important Vovk's purchases of vacuum devices for the cabinet of physics of Novo Mesto

Tool	Price	Year of purchase
Airtight vessel ⁷⁰⁶		1857
Saussure's hygrometer, a gift from the canon Josef Žagar		1862
Two Geissler's cathode ray tubes	Josef Žagar contributed for them 10 florins of Austrian value (fl öw) ⁷⁰⁷	1869
Ruhmkorff's inductor	bought for 150 fl öw	1869
Another pair of Geissler's cathode ray tubes		1870

⁷⁰⁶ Reports (Izvestje) Novo Mesto Grammar School (Novomeške gimnazije), 1857, 33.

⁷⁰⁷ Reports (Izvestje) Novo Mesto Grammar School (Novomeške gimnazije), 1869.

Table 6-15: Other books of non-Jesuitical authors in Ljubljana Jesuit library

Year of purchase	Ages upon purchase	Writer	Language (or translation from language)	Reference code in NUK
1750-1758	29	Hire	Germ. (Lat.)	4086
1756	6	Wolff	Germ.	4136 (2)
1750-1758	11	Wolff	Lat.	4049 (2)
1754	31	Ozanam	Fr.	4384
1751	13	Brixianus	Lat.	12070
1754	25	Musschenbroek	Lat. (Dutch)	8458
1731	23	<i>Academia del Cimento</i> in Musschenbroek's translation	Lat. (It.)	4283
1754	5	Parisian academicians	Germ. (Fr.)	8361 (2)
1696	40	Gassendi	Lat.	4284
1754	14	Magalotti	It.	2303

stored three of them in the shelves with medical works.⁷⁰⁸ The inventor of the phlogiston theory, Georg Ernest Stahl of Jena, excelled himself as a chemist, doctor and university professor in Halle until he became a court physician and a councilor of the Prussian king; Zois also readily used his own collection of Stahl's books. Novo Mesto Franciscans bought all Boyle's discussions of vacuum and other works, like Valvasor in the nearby Bogenšperk; so, all versions of Boyle's vacuum pump were well looked after. They also obtained the assumptions of experimental physics of Boyle's correspondent Placentini, called Tarvisini, as well as Boyle's correspondent from the Kiel and Altdorf universities, Günter Christophe Schelhammer. Placentini rejected Schelhammer's assumptions about the vacuum in the barometer and preferred Leibniz's ideas. Even in the late Baroque, the Franciscans of Novo Mesto (New City) taught according to Leibniz's guidelines, because they purchased many Wolff and Sturm's works with the adaptations of the Augustinian monk Desing included.

Novo Mesto Franciscan entered their Newtonian era to end the Cartesian influences against the vacuum by the intervention of Englishman Keill.⁷⁰⁹ Keill studied under supervision of the professor David Gregory in Edinburgh, who immediately after the printing of Newton's *Principles* began to teach about them. Keill accompanied Gregory even to Oxford when Gregory became a professor of

astronomy there in 1702. Keill soon acquired himself a chair of professor of philosophy and was among the first to lecture on Newton's natural sciences. He taught the freemason John Désaguliers, whose experimental manual was purchased by the Jesuits of Ljubljana in 1754. Keill proved Huygens' Theorem on centrifugal and circular motion.

A Novo Mesto (New City) edition of Keill's textbook was published simultaneously with the Minimite (Minims) Friars' adaptation of Newton's *Principles*. Both books were urgently needed by the Franciscans of Novo Mesto (New City) at the beginning of their higher education lectures under the orders of Maria Theresa and van Swieten. Van Swieten's compatriot, the Dutch Newtonian advocate Musschenbroek, was not only popular among the Novo Mesto (New City) Franciscans, but also with the Jesuits of Ljubljana. In 1754 the Jesuits of Ljubljana bought Musschenbroek's book in a half of decade old French translation, while the Franciscans of Novo Mesto (New City) preferred a later edition of the Latin originals. Shortly after Musschenbroek's death, five other Musschenbroek's publications were listed in F. Wilde's catalogue among Ljubljana Lyceum works in a total of six Musschenbroek's books. Except for *Essai*, all of them were published in Latin language. Two books were printed in the Netherlands and Vienna, and one even in Ljubljana by B.F. Erberg and his students. All works were printed in the Quarto Format between the years 1739-1768 (1739, 1753, 1754, 1754, 1761 and 1768). Four of them had a general, emphasized

⁷⁰⁸ D. Mušič, From the history of medicine, in: *Medical examiner* (1938), 445.

⁷⁰⁹ Keill, 1742, 196-208.

experimental character with vacuum experiments: one dealt with magnetism and the other focused the familiar but awesome capillarity.

The Franciscans of the Novo Mesto liked to read the writings of former professors of Ljubljana including Biwald, Ambshell or Neumann, who advocated Bošković's description of the vacuum. Of course, those were mainly the schoolbooks, which were recommended by the Viennese authorities.

More than a textbook of benevolent but less learned Kersnik, the influence of the Ljubljana Jewish mathematician Gunz spread across all Carniola. The mathematical textbook of his father Simon Gunz (Guntzhausen, * 1743 Augsburg; † 11. 11. 1824 Prague) became the basis of instruction even in Novo mesto, where the fans of French Napoleonic occupation did not completely renounce the Franciscan help. The Franciscans of Novo Mesto taught their young monks, among them Vodnik, in two years of philosophical studies. After the break during the Josephine reforms, until the March Revolution (1848), they again educated their pupils in two philosophical years; they did not want to accept laymen in Franciscan philosophical course because the townspeople of Novo Mesto did not want to contribute money to cover part of the costs.⁷¹⁰

6.4.4 Vacuum Devices of Bernard Vovk in Novo Mesto

The Franciscan Bernard Vovk was a longtime professor of physics, meteorologist and gymnasium (Grammar School) headteacher in Novo mesto. Among his talented students was a famous researcher of the speed of electromagnetic waves in a vacuum Ignac Klemenčič, professor in Graz and Innsbruck. With the help of the most modern barely a decade old Geissler's Bonn vacuum tubes, Vovk learned all about the mysteries of the expansion of waves in a vacuum very early. With his purchase of Geissler's vacuum cathode ray tubes, Vovk showed to his students the best vacuum at that time only a couple of years after the Grammar School in Ljubljana acquired similar devices. Of course, the vacuum devices were not among the cheapest tools, so the canon Josef Žagar was very helpful to professor Vovk.

⁷¹⁰ Vrhovec, 1891, 269.

For Žagar's 1 fl öw it was possible to buy a kilo of beef at that time. Thus, for the price of the Geissler's electrical glow discharges in diluted gases leading to the cathode ray tubes, Slovenian ancestors could already afford a pleasant feast for well-padded tables, which would be submerged under the weight of delicious roasts.

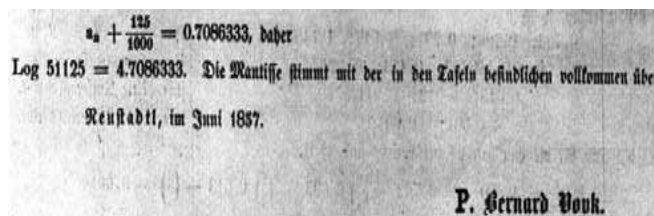

Figure 6-35: Vovk's signature under his only published scientific discussion in mathematics with notes of the use of barometers in meteorology (Vovk, 1857, 30).

6.5 Vacuum of Franciscans in Ljubljana

6.5.1 Introduction

The Franciscans of Ljubljana have been a decoration of their home city for eight centuries; first on the premises of the now heavily used food market, and later for more than two hundred years on the other side of the Ljubljana river, on the square of St. Mary, which was later renamed to the poetical saint France Prešeren. After many years of efforts, however, the writer of the present lines succeeded in inspecting the foundations of books stored there and thus he penetrated in the spirit of the former Franciscan design. What was the Franciscan opinion about early vacuum techniques given that the first Carniolan vacuumist Prince Janez Vajkard Turjaški (Auersperg) was buried right on the premises of the former Franciscan monastery on Vodnikov trg, and the ashes of his bones could soon serve to decorate the new Ljubljana subterranean garages?

6.5.2 Škerpin's Merits

The scientific efforts of Jesuits were the hot topics of the past decades in history of science. The Franciscans and Minims were always their match, to mention only Marin Mersenne (* 1588; OM 1611; † 1648). Therefore, the Franciscan and Minims' scientists of the past centuries also deserve some glory; it is high time to reverse the

roles and to give the Franciscan scientists of the past centuries the fame they deserve.

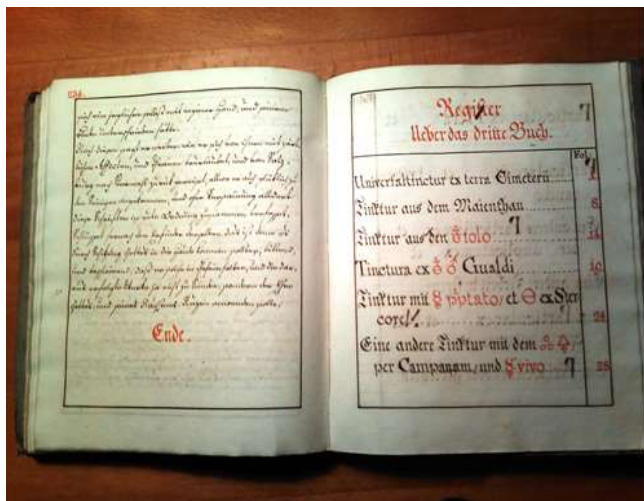

Figure 6-36: The first page of the index of the clear copy of alchemistic manuscript of Alexis Baron Ruessenstein's, the son of Konrad Baron Ruessenstein from the castle Strmol (Ruessenstein, ibid. FSLJ-29 F 54, p. 235 (The courtesy of Dr. Prof. Miran Špelič, OFM)).

Škerpin's Acquisitions of Books about Mathematical Sciences provided the basics of technical knowledges of Ljubljana Franciscans who bothered to read Škerpin's books. The Franciscan provincial Škerpin acquired an extraordinary great amount of the contemporary and older philosophical literature for the Ljubljana Franciscans' Library. His philosophy still included mathematical, physical, and biological sciences. With his efforts Škerpin paved the way for the Bavarian Franciscans Zinsmeister and Hieber who began the modern mathematical and technical lecturing in Franciscan schools nearly half of a century after Škerpin's death in 1755.

The achievements of Jesuit scientists were thoroughly researched during last decades. It was considered that you could find a Jesuit behind most of the scientific accomplishment of 17th or 18th centuries. The idea was not far from the truth because Athanasius Kircher or Rudjer Josip Bošković really proved to be among the best. But the Jesuit studies seem to have passed their peak and it is high time to research the early modern science success of the other religious orders. The Parisian Minim Marin Mersenne (* 1588; OM 1611; † 1648) was in a way the German-Roman Jesuit Kircher's match and several Franciscans

were not much less important. Therefore, it is high time to give the Franciscan scientists of the past centuries the fame they earned.



Figure 6-37: Alexis baron Ruessenstein about the Quicksilver in his original handwriting in Ljubljana Franciscans' Library (Ruessenstein, ibid. FSLJ-29 F 56, p. 93 (The courtesy of Dr. Prof. Miran Špelič, OFM)).

We celebrated the 800th anniversary of Franciscan order in the year 2009. The Franciscans of the Carniola's capital Ljubljana (now Slovenia) were mentioned for the first time in 1242, soon after the establishment of Franciscan order. Later they were unable to survive the protestant challenge in 1569,⁷¹¹ when almost all citizens of Ljubljana accepted Luther's Christianity. After several decades, the Franciscans returned to Ljubljana, but after the death of the Emperor Josef II Gabriel Gruber's best student Jožef Marija Šemerl rearranged former Franciscan monastery for the purposed Lyceum. Gruber was among the best engineers in Habsburg Monarchy and later became the General of the Jesuits' Order. After the earthquake (1895) Ljubljana got its marketplace in the former site of the Lyceum. In the meanwhile, the Franciscan baroque monastery with now Franciscan church of St. Mary's Assumption stood still, even if Mary had to give up her square's name to the best Slovenian poet Franc Prešeren for the sake of the Communist Regime in 1949. Between the years 1646 and 1660 the Augustinian church

⁷¹¹ Stanislav Bahor, Samostanske knjižnice na Dolenjskem. Frančiškani in knjižnica Frančiškanskega samostana v Novem mestu. *Rast.* 66/3-4 (205) pp. 387-409. Here pp. 396, 397, 398.

was erected on behalf of the Baron Konrad Ruessenstein from the Upper Carniola castle Strmol. The front walls were finished in 1700, and half of a century later the famous Italian sculptor Francesco Robba made the main altar. The Emperor Josef II suppressed the Ljubljana Augustinians in 1784 and somewhat later gave their monastery and church to their Franciscan neighbors from the opposite side of Ljubljanica River. The Barons Ruessenstein did not care much for the change and still took care for the church. The Baron Alexis Ruessenstein gave his important alchemical manuscripts to the new monastery owners, the Franciscans.⁷¹²

Žiga Škerpin renewed the Franciscans' Library which was in his times on the right side of the Ljubljanica River. He was the provincial of Croatian-Carniolan province between the years 1732-1735 and again between the years 1745-1748. He became the court's secret advisor,⁷¹³ and acting general definitor of all Franciscans. During his numerous travels through the foreign metropolis including Italy and Spain he collected books for Ljubljana Franciscans' Library established soon after their supposed arrival in 1233.⁷¹⁴ Between the years 1733-1746 Škerpin brought to Ljubljana no less than 1668 titles of the books which were published in 2627 volumes. We'll deal mostly with the mathematical-technical part of his contributions to Ljubljana Franciscans' Library.

In 1744/45 Škerpin also rebound a great deal of his books which he inherited from his predecessors in Ljubljana Franciscans' Library, although that part of his work is valued differently by modern researchers of Ljubljana Franciscans' Library because older covers and some marginalia were lost in the process. It is said that Škerpin got many of his new leather-bound beauties almost for free

⁷¹² Alexis baron Ruessenstein, Drittes Buch / von denen zusammen getragenen Schriften des Herren Alexij Baron von Ruessenstein (reference code of Ljubljana Franciscans' Library (FSLJ)-29 F 54), (1)694. Copy on 234 pages; Alexis baron Ruessenstein, Drittes Buech / von denen zusamm getragenen Schriften des Herren Alexij Baron von Ruessenstein (von Salzburg) (FSLJ-29 F 56), (1)694. Original on 513 pages.

⁷¹³ Franjo Emanuel Hoško, *Franjevačke visoke škole u kontinentalnoj Hrvatskoj*. Zagreb: Kršćanska sadašnjost, 2002, p. 313.

⁷¹⁴ Maks Miklavčič, Škerpin (Škrpin) Žiga (keyword). *SBL*. 3/10 (1967) p. 329.

during his frequent travels through Italy and Spain, because he just knew how to behave in the learned European societies. He brought so many newly printed items to Ljubljana that he had to rebuild the new library facilities in the Franciscan Monastery on today's Vodnik Square in Ljubljana. I am sorry to say that those Škerpin's accomplishments did not benefit much his Franciscan descendants because Škerpin's Franciscan monastery was rearranged to serve the purposes of Lyceum soon after Škerpin's death.

Žiga Škerpin did not only considerably extend the rooms of Franciscans' Library. He wrote several textbooks although they were used in manuscript form and were not printed. In the Trsat above the Croatian Rijeka and in Croatian north-western city of Klanjec he accomplished the textbooks on Aristotle's physics with the descriptions of the up-to-date modernized achievements. His manuscripts are still preserved in Ljubljana Franciscans' Library today.⁷¹⁵

The Ljubljana Franciscans also acquired Johann Michael Conradi's optics which marked the beginning of endoscopy, the optical examination of the inner hollow organs of human body. Conradi was a teacher at grammar school in Bavarian Coburg and later became a castellan master of French language in Dresden. His publication was approved by the Philosophical faculty of the Jena University. Conradi dedicated his work to the duke of Saxony, Anton Ulrich. According to the statement on the back cover the previous owner of Conradi's book before the Ljubljana Franciscans was Anton Dr. Benedikt zu Lockerberger in 1737.⁷¹⁶

6.5.3 Early Franciscans in Ljubljana Questioned the Vacuum

The Ljubljana based Franciscan scholars learned their early opinion about vacuum from the book Walter Burley (Burleaus, Burleigh, * about 1275; †

⁷¹⁵ Žiga Škerpin, *Commentaria in Aristotelis Stagyrtae octo libros Physicorum*. Manuscript. The first book (448 pages, 1714, FSLJ-6 d 4), and the second book (431 pages, Trsat, 1718, FSLJ-6 d 57).

⁷¹⁶ Johann Michael Conradi, *Der dreyfach geartete Sehe-Strahl in einer kurtzen, doch deutlichen Anweisung zur Optica oder Sehe-Kunst*, Coburg: Johann Fridrih Regelin, 1690 (FSLJ-18 c 6).

1244/45), who received a PhD in Paris and, since 1324, worked on Sorbonne as the opponent of Ockham with his razor included. A hundred years later writer Arnù (Niccolò Arnù, 1629 castle of Mirecourt "six miles" from Verdun-1692 Bologna), whose works the Franciscans also read in Ljubljana, also quoted Burleigh.⁷¹⁷ A Dominican monk (Praedicatorum) Arnù (Arnù) served as professor of metaphysic in Lyceum of Padua.

time noted by a and b and denied the possibility of motions in a vacuum. He quoted both Greek and Arabic sources for his ideas of weight.⁷²⁰



Figure 6-38: The title page of Burleaus's philosophy with physics of vacuum in the Ljubljana Franciscans' library.

Figure 6-39: A sketch of a movement in a vacuum after Burlaeus's fourteenth-century suggestions, which were printed in Venice even two and half century later (Burlaeus, 1609, 479; F).

Burleaus wrote about vacuum (Vacuo),⁷¹⁸ as usual, within remarks to the fourth Aristotle's book of physics. Burleaus was interested in linear motions in a vacuum, where in Aristotle's style he raised objections and dismissed them. He tried to determine the ratio between the vacuum and the full amount of matter in terms of time and speed, while proving that movement in a vacuum is not possible.⁷¹⁹ Burleaus illustrated the relationship between vacuum and fullness and movement in them by a cute picture. He imagined the points of

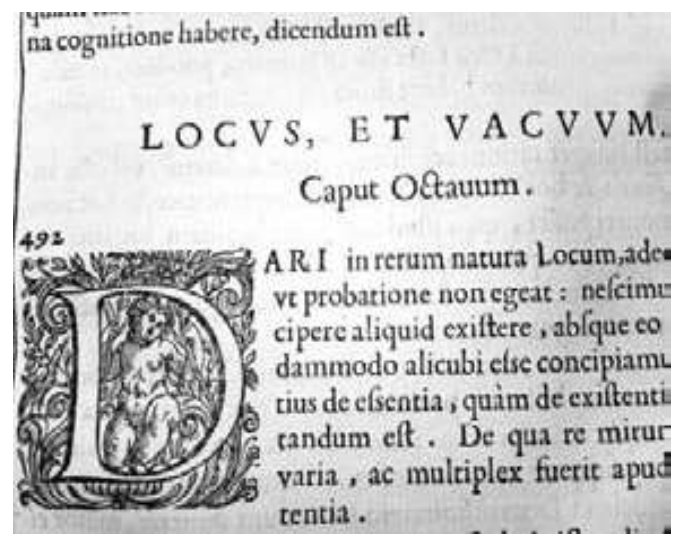

Figure 6-40: Nicely decorated initials of the Chapter on Vacuum in great Work of the Cardinal Pallavicini (Sforza Pallavicini, 1625, 90); F.

The Ljubljana Franciscans read the philosophy of Franz Titelman (Titelman, * 1498 Hasselt in the district of Liège; OFM cap; † 1537), who taught in Leuven and defended the ideas of Erasmus of

⁷¹⁷ Arnù, 1685, 149.
⁷¹⁸ Burlaeus, 1609, 4: 476.
⁷¹⁹ Burlaeus, 1609, 4: 478.

⁷²⁰ Burlaeus, 1609, 4: 479-480.

Rotterdam; finally he joined the Capuchins. Titelman shared Aristotelian opinion about the impossibility of natural vacuum; he provided a Cartesian example of water in a glass and the water clocks (gnomon).⁷²¹



Figure 6-41: The picture of Roman Emperor in the middle of his Battle Vortex, when a swarm of bees came to his aid, dedicated to the Pope Urban VIII whose coats of arms included those bees. That almost meter long fold picture was included in a book of Sforza Pallavicini kept in Ljubljana Franciscan Library (Sforza Pallavicini, 1625); F.

In September 1625 the marquess Pietro Sforza Pallavicini from important Parma family dedicated his book *World of Philosophy* to the pope Urban VIII. The book was his doctorate in philosophy at Roman Jesuit College. Žiga Škerpin, the Head Ljubljana Franciscans, acquired that book a century later. Pallavicini's defense was adorned by a great public. Besides the Pope himself, twenty Cardinals also attended that fest. Pallavicini otherwise printed the last pages of his book also in separate edition on ten sheets full of praise of Pope the Platonist, his bees, and even the bees of king Heron.

Pallavicini glorified the Pope with two big images full of Barberini's bees. That honor certainly brought enough money for luxurious edition of the book and later brought the red cardinal hat to Pallavicino in the year 1659. Antonio Tempesta (1555 Florence-1630 Rome) painted the bigger picture 70 cm long. The son of Matthias Greuter (ca. 1566 Strasbourg–1638 Rome), Joseph Federic Greuter engraved it with a motive design of Roman Emperor. The emperor took advantage of his

⁷²¹ Titelman, 1582, 110-111.

friendly bees to overcome the Germans. Pallavicini also provided the dedication songs on the end of book filled with the motives of bees. Pallavicini became a member of Galileo's Academy dei Lincei in the Year 1629. In the year 1624, however, Pallavicini defended Galileo from accusations of Jesuits. After Galileo's conviction in the year 1632, Pallavicini felt out of favor and had to serve at province together with his friend Giovanni Ciampoli who was a member of Academy dei Lincei already in the year 1618. Barely after his cunning entrance into Jesuits' society despite of the opposition of his father, Pallavicini has returned to the Roman metropolis to which lead all ways. Between the years 1639 and 1643 Pallavicini taught philosophy at Roman College, then he became the professor of theology for eight years. The famous speaker Pallavicini wrote book on language style in scientific writing, that Škerpin read in his Ljubljana Franciscan's headquarters.⁷²²

Pallavicini split his philosophy into three books, among which he focused on mathematical sciences in the middle second book. So, in his great custom he adjusted Aristotelian scheme in modern ways. Despite of that Pallavicini was not very kind to Democritus', Epicurean or Lucretius' support of the vacuum without viscosity. Pallavicini used the publications of Leyden Professor of Literature Joseph Justus Scaliger, of Graz Professor Del Rio, Zabarella, Burlaeus (Walter Burley), Scotus, and Duran, probably Jacob Honoratus Durand.⁷²³ Pallavicini outlined the mathematical sides of sciences even through Plato, Pythagoras and Averroes,⁷²⁴ which has been good for the promotion of Galileo, although Pallavicini did not mention his friend Galileo by name. Pallavicini stressed the successes of chemists in their research of new substances, specifically mercury and other metals.⁷²⁵

Despite of his membership in Galileo's Academy dei Lincei, Pallavicini in "Mathematical" way refused nine years previously officially prohibited Copernican movement of earth with other worlds included. Pallavicini insisted in assumption of four elements.⁷²⁶ Of course, knew all the details about

⁷²² Verhulst, 2005, 115; Svoljšak, 2006, 211-212.

⁷²³ Sforza Pallavicini, 1625, 55, 70-71, 82, 85, 92, 93 – 95.

⁷²⁴ Sforza Pallavicini, 1625, 47, 50, 69.

⁷²⁵ Sforza Pallavicini, 1625, 64, 71.

⁷²⁶ Sforza Pallavicini, 1625, 115, 116.

usefulness of Supernova from Year 1572 for the determinations of size of the planet Venus as it attained the apparent magnitude of Venus (about -4) seen by daytime. Pallavicini also followed the observations of constellation of Cygnus (Swan) from the years 1600 and 1604.⁷²⁷ Pallavicini even did not neglect the celestial densities and rarefaction including the recently discovered sunspots.⁷²⁸ Despite Tycho's concerns, Pallavicini still classified the comets among the meteorological evaporations of earth in the highest areas of atmosphere, and not among the celestial phenomena.⁷²⁹

Ljubljana Brethen, who purchased two Venetian editions of his natural philosophy. In Padua during the year 1603-1606 Faber was professor of philosophy, and then he taught theology; in 1625, he became the provincial. The earlier second edition of his book issued in 1602 was used by Joseph, probably Jožef Urbanizi, who has lectured on philosophy in Novo Mesto (New town) until his death. Faber has compared Averroes' and Scotus' opinion on the vacuum. He referred to Avicenna's and Alessandro Achillini's (b. 1463; d. 1512) description of the movement in the vacuum and approved Zabarella's critique of Averroes.⁷³⁰ Faber discouraged the description of the vacuum of Francisco Piccolomini,⁷³¹ because Piccolomini supposedly falsified Scotus' opinion. Between 1561-1601 in the Paduan University, Piccolomini defended Averroes' version of Aristotle, combined with Plato's philosophy. In 1584, Piccolomini has been in serious conflict with a fellow professor Zabarella,⁷³² whom Faber in his attempts against Averroes most passionately supported and quoted. Of course, Zabarella's most powerful books were also in Ljubljana Franciscans' library together with the transparent summaries of Aristotelian and Averroes' works produced by Paduan professor Zimara, which was also acquired by Škerpin. The Ljubljana Franciscans inherited even Aristotelian work with Averroes' comments from the year 1560, which was owned by their predecessors in today's Prešeren square, the Barefoot (Discalceati) Augustinians, in 1664. The most inflamed reader of Zimara's and other compilations of Aristotle was Leonard Butorčič (d. 16. 2. 1657 Trsat), who has been for a while Guardian (Custos). He put his inscription into the bookplates of many Ljubljana bookand especially in two Zimara's editions. The alleged Leucippus' teacher Eleatic Melessius (Melissus, Μέλισσος ὁ Σάμιος; fl. 5th century BC) from Samos enabled the modifications of advocates of moving in vacuum space despite of Plato. Zimara sketched gradually decreasing resistance of the surroundings made up of the solid matter, liquids, through the air all the way to a vacuum without a viscosity. The vacuum supposedly did not allow the pushing of the motors and would thus prevented the movement itself.⁷³³ The Pythagorean Xuthus thought about the

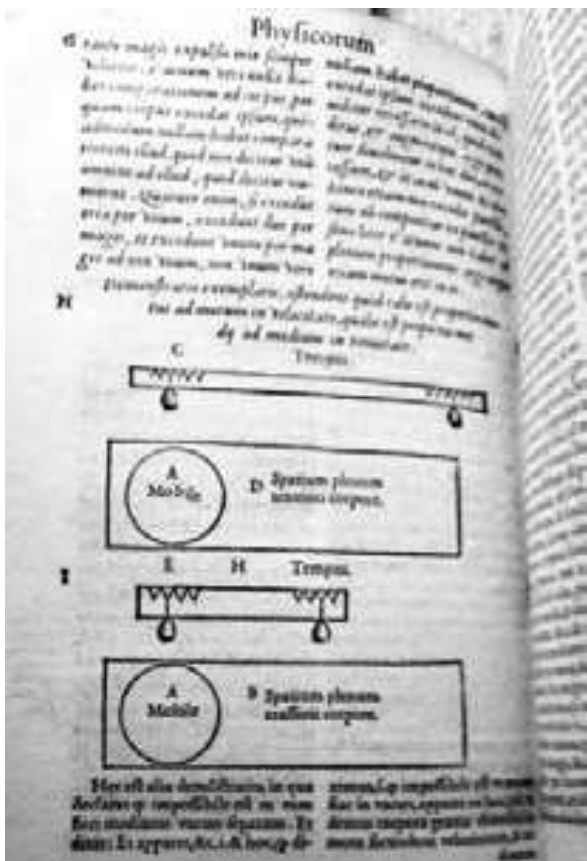

Figure 6-42: Picture used to illustrate the movement of substances in Zimara's summary of Aristotelian and Averroes's works in Ljubljana Franciscan library (Aristotle, 1562, 158v (FSLJ-5 D 4)); F.

The regent in Parma High School, the lector in monastery of John the Evangelist and Paduan professor of Metaphysics Franciscan Philipp Faber (Fabri, Faventino, * 1564 Spina di Brisighell in District Faenze; OFMconv 1582 Cremona; † 28. 8. 1630 Padua) was among the strong favorites of his

⁷²⁷ Sforza Pallavicini, 1625, 115, 116.
⁷²⁸ Sforza Pallavicini, 1625, 113.
⁷²⁹ Sforza Pallavicini, 1625, 143

⁷³⁰ Faber, 1602, 260; Faber, 1606, 239-240.
⁷³¹ Faber, 1602, 259; Faber, 1606, 237, a 240.
⁷³² Mikkeli, 1992, 19.
⁷³³ Aristotle, Averrois, Zimara, Mantini, 1562, 149r, 152r, 158r, 158v, 162v.

possibility of separating and isolating the vacuum which could allow the motions in full limited cosmos.⁷³⁴ In any event, Zimara at least did not mention the ecclesiastical authorities in this scientific dispute, as it became habitual later, and he even contributed interesting sketches. Zimara pointed out Gallen's error in describing the Aristotelian concept of time.⁷³⁵ In his text printed in smaller characters at the end, Zimara stated Boethius' and Bachonis' (Roger Bacon OFM) opinion about the Aristotelian fourth Book of Physics.⁷³⁶

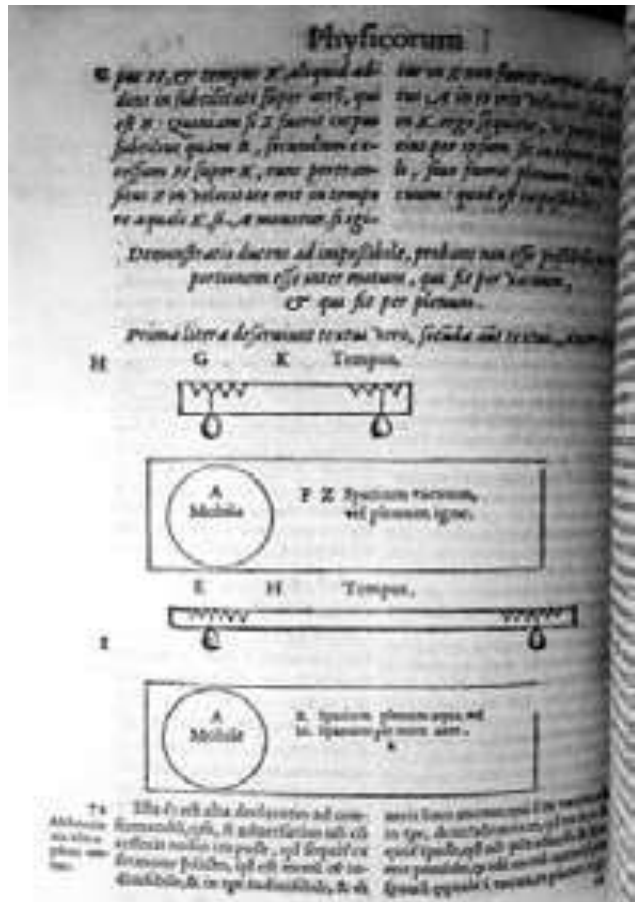

Figure 6-43: Picture used to illustrate the allegedly impossible movement in vacuum full of fire. Under it there is a sketch of motions in water and air by Zimara's Summary of Aristotelian and Averroes's works in Ljubljana Franciscan library. The first uppermost illustration (litera) designs allegedly right course of developments; the other illustration tried to check out the error in Averroes' opinions (Aristotle, 1562, 162V (FSLJ-5 D 4)); F.

The pagan Hellenist Themistius (Themis, Themistus, Themistius, * 317 Paphlagonia in

⁷³⁴ Aristotle, Averrois, Zimara, Mantini, 1562, 167r.

⁷³⁵ Aristotle, Averrois, Zimara, Mantini, 1562, 492v, 293v.

⁷³⁶ Aristotle, Averrois, Zimara, Mantini, 1562, 179r.

central Anatolia; † 388 Constantinople) was a senator and city prefect of Constantinople, where he also taught eclectic philosophy of Aristotle mixed with Plato and religious freedom for two decades.⁷³⁷ The editors of his book were Hermolao Barbaro and Marc Anton Zimara.⁷⁴¹ Barbaro and Zimara resolved alleged antic contradictions. Škerpin acquired that book for Ljubljana Franciscan Library. Among the first of that sort in his era, Zimara did not discuss much of Aristotelian physics books. So, H. Barbaro provided enough details to address the fourth Aristotelian book of physics with a discussion of vacuum included. For example, he described the water clock and introduced Democritus and Leucippus' vacuum as a tool for the separation of Particles of Substances with the endless empty spaces of universe. Against Democritus and Leucippus, the Aristotelian Barbaro highlighted Zeno's Paradox, Melissos of Samos and Xuthus alias Bouthus, just like Marc-Antonio Zimara did in the posthumous edition of his book in the year 1562. The problem with vacuum was its absence of volume, although the fans of Pythagoreans placed a lot of vacuums into the Universe, and Plato approved voids in his Dialogue Timaeus.⁷³⁸

Cardano's works, which were often purchased by the Franciscans of Ljubljana, were created from completely different aspirations. The famous Italian mathematician Cardano skipped different themes from chapter to chapter; he did not write directly about the vacuum, but much more about siphons and related vacuum devices which used water,⁷³⁹ the ship on the ropes under the sea connected with five other ships as a submarine.⁷⁴⁰ He did not forget the Archimedes spirals for pumping; his flow of air was upgraded with sketches of water mills at the end,⁷⁴¹ and he described the motion of the universe and the solar clock.⁷⁴² Of course, everything sold well because several Cardano's works were long on the Papal index of prohibited books.⁷⁴³

⁷³⁷ Svoljšak, ibidem, 212.

⁷³⁸ Themistius, Aristotle, Nogarola, Barbaro, Zimara, 1554, 42r, 42v, 43v.

⁷³⁹ Cardano, 1627, 690.

⁷⁴⁰ Cardano, 1627, 691.

⁷⁴¹ Cardano, 1627, 53-56.

⁷⁴² Cardano, 1627, 373.

⁷⁴³ Benedict XIV, 1758, 49.



Figure 6-44: Illustration of motion of a body thrown by hand in Zimara's Summary of Aristotelian and Averroes's works in Ljubljana Franciscan library (Aristotle, 1562, 334V (FSLJ-5 D 4)); F.



Figure 6-46: The title page of Cardano's research published in 1627, which was thirteen years later acquired for the Ljubljana Franciscan Library.

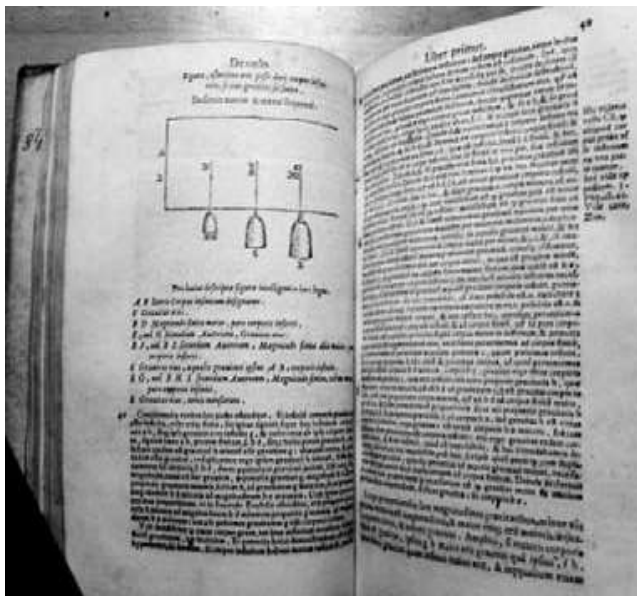

Figure 6-45: Force of gravity and the acoustics of bells in Zimara's Summary of Aristotelian and Averroes's works in Ljubljana Franciscan library (Aristotle, 1562, 39v (FSLJ-5 D 4)); F.



Figure 6-47 Propriety entries of many older owners of book of Faber in Ljubljana Franciscans' library (Faber, 1602).

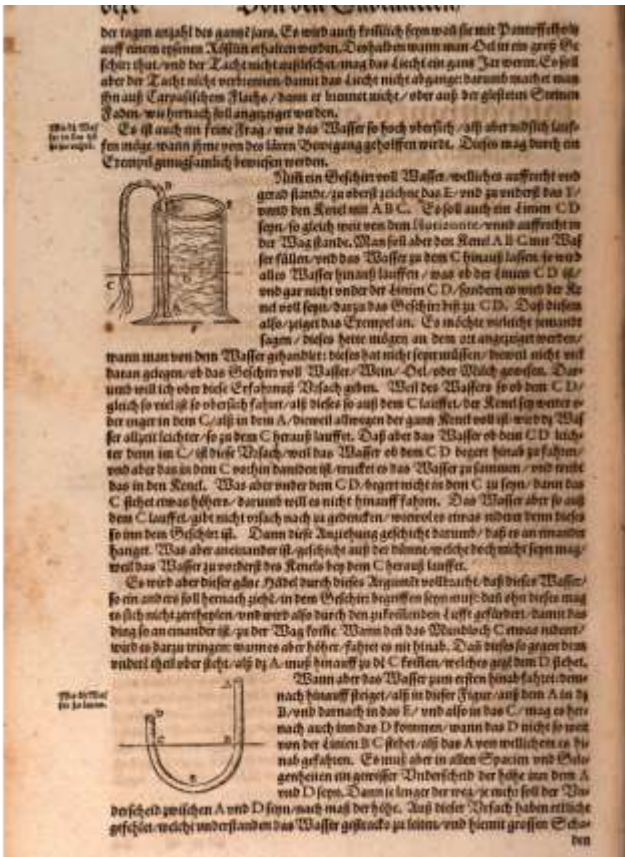

Figure 6-49: Title page of the third edition of Faber's book in Ljubljana Franciscans' library (Faber, 1606).



Figure 6-50: The initial discussion of the vacuum from the Faber's book at the Ljubljana Franciscans' library (Faber, 1606, 236, 257).

Figure 6-48: Cardano's siphon (Cardano, 1627, 690) followed by a submarine in lower picture.



Figure 6-51: The cover page with bookplate of Zabarella's book at the Ljubljana Franciscans' library (Zabarella, 1601)

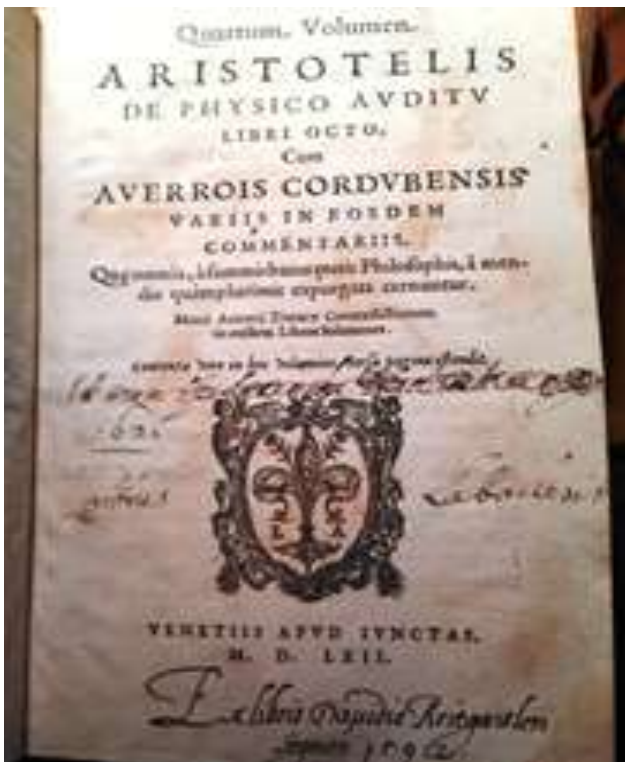

Figure 6-52: The cover page of the Aristotle's and Averroes's Summaries with Butorčić's Ex Libris at Ljubljana Franciscans' library (Aristotle, 1562).



Figure 6-53: The reference codes noted at the inside of the cover page (front endpaper, FEP) of Zimara's Summary of Aristotelian and Averroes's works in Ljubljana Franciscan library. The still valid reference code 5 D 4 was crossed out by the Franciscan librarian trying to modernize the arrangement during WW2, but his attempt was never approved by his Franciscan boss (Aristotle, 1562 (FSLJ-5 D 4)); F.



Figure 6-54: The beginning of discussions about vacuum in Zimara's Summary of Aristotelian and Averroes's works in Ljubljana Franciscan library (Aristotle, 1562, 147r (FSLJ-5 D 4)); F.



Figure 6-55: The demonstration of motion in given time at Zimara's Summary of Aristotelian and Averroes's works in Ljubljana Franciscan library (Aristotle, 1562, 179v-180r (FSLJ-5 D 4)); F.



Figure 6-57: The spine of Tartareti's († 1522 Paris) Philosophy bind in leather full of his insightful descriptions of vacuum and atoms (Tartareti, 1621); F



Figure 6-56: The illustration of motion in time by Zimara's Summary of Aristotelian and Averroes's works in Ljubljana Franciscan library (Aristotle, 1562, 293v (FSLJ-5 D 4)); F.

Among Butorčič's writers was the particularly famous Scotus' fan Peter Tartareti (Tartareti), the professor and lecturer of the Paris theological faculty. That's why Butorčič got two of his books, even if he wrote his proprietary entry only in the first volume devoted to logic while in the second volume about the physics and metaphysics the title page was lost in the storms of the centuries. The Cistercians of Stična also read Peter Hispanus' (supposedly later Pope John XXI) *Summulae* in Basel edition of the magister Peter Tartareti (1514) with the additional notes about six Aristotelian books of the editor master Martin Molenfelt from Livonia by Baltic.

The volume consisted of two parts (NUK-5070; NUK-5071) bind with the cardboard while using the leather for spine and the edges. The format was A4 (similar to Imperial Octavo), 4 cm thick, without any bookplates. Tartareti had published images of global astronomical systems. Even before the second half of the book, he explained *Isagoge* (*Εἰσαγωγή*) of Porphyry of Tyre (Πορφύριος, c. 234 – c. 305 AD) by the books of Aristotle logic. In the item bind to it (Adligate, NUK-5071), Tartareti commented on the books of

Table 6-16: Ex Libris of (former) guardian Leonard Butorčič in the books of Franciscans of Ljubljana

Author	Title	Year of publication	Butorčič's entry
Reisch, Gregor	Margarita philosophica (Filosofica). Venegia (Venice): Barezzo Barezzi (FSLJ-16 b 20)	1599	1648
Tartareti, Pierre	Scotistae Subtilissimi in universam Philosophiam, the first part of Petrus Hispani Summula. Venetiis: Sarzi (FSLJ-19 g 13)	1621	1621 in Senj, later owner in 1653 general lector and definitor Danijel Lukan († 15. 6. 1707 St. Leonard)
Aristotle; Averroes; Zimara, Marcanton; Mantini, Jakob	Aristotelis omnia quae extant opera. Venetiis: Junctas (FSLJ-20 h 10)	1562	1644, former owner: 1592 Davidi Reitgartleri Segmen
Aristotle; Averroes; Zimara,	Quartum volumen Aristotelis de physico auditu libri octo cum Averroes Cordubensis variis in eosdem commentariis (FSLJ-5 d 4)	1562	1620, former owner: 1592 Davidi Reitgartleri Segmen 1592 Davidi Reitgartleri Segmen (David Reitgartler, the Carniolan noble from Senj)
Brasavoli, Irenaei (* 1562 Ferrara; OFMobs; † 1621)	Questionum universalium... Scoti. Venetis: Varisci (FSLJ-10 g 7)	1599	Unknown

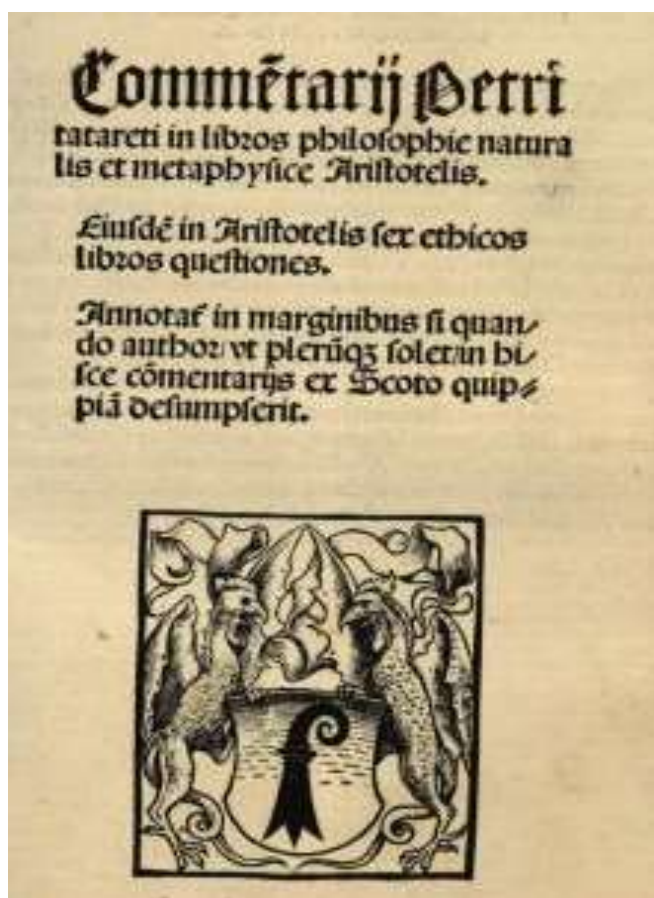

Figure 6-58: Tartareti's sketch of Aristotelian natural sciences in Ljubljana Franciscans' library (Tartareti, 1621, 148).

the Aristotelian Philosophy of Nature, which filled the last half of the book. He described physics, production by decay, and then pictures of winds in the chapter on meteorology,⁷⁴⁴ and finally wrote about the soul, metaphysics and Ethics in Aristotelian frames. In Ljubljana Franciscan copy of Tartareti's comments on physics we read about Anaxagoras's, Pythagoras's and Democritus's concept of vacuum or atoms. Nonetheless, scholastic fear of empty prevailed.⁷⁴⁵



Figure 6-59: The Ljubljana Franciscan inscriptions in Tartareti's book (Tartareti, 1621).

⁷⁴⁴ Tataretus, 1514, 15v, 71, 87r.

⁷⁴⁵ Tataretus, 1621, 81v.



Figure 6-60: The title page of the Aristotelian Parisian collected works of Professor Du Val of 1629 in the Ljubljana Franciscan Library.

Of course Škerpin was in no way left behind Butorčič; so, he also obtained the mighty Greek-Latin adaptation of the collected Aristotelian works produced under the goose-pen of the Parisian Professor Guillaume Duval (Guglielm du Val, * about 1572; d. 1646); both of those bulky books are so full of knowledge that they cannot be lifted without a great force. Duval from the Parisian medical faculty of course there bilingually refused vacuum (Inani);⁷⁴⁶ such approach dogged the Aristotelian fans for two millennia.

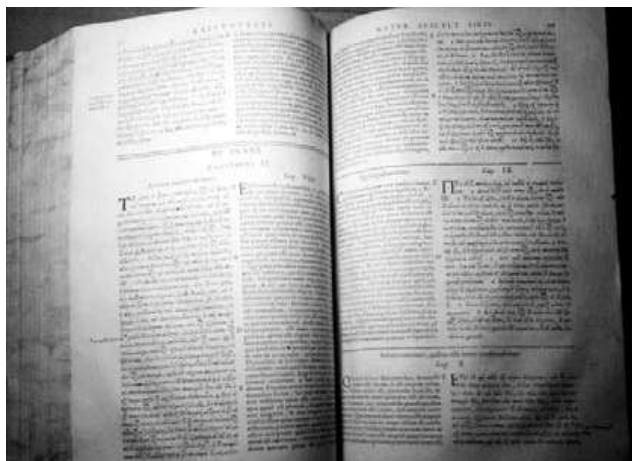

Figure 6-61: Aristotelians accidentally scorned vacuum for the next two millennia in the Parisian collected works (Aristotle, Du Val, 1629, 358) in the Ljubljana Franciscan Library.

⁷⁴⁶ Aristotle, Du Val, 1629, 358-364.



Figure 6-62: The title page of de la Fuente's notes on the vacuum of 1631 in the Ljubljana Franciscan Library (Fuente, 1631).

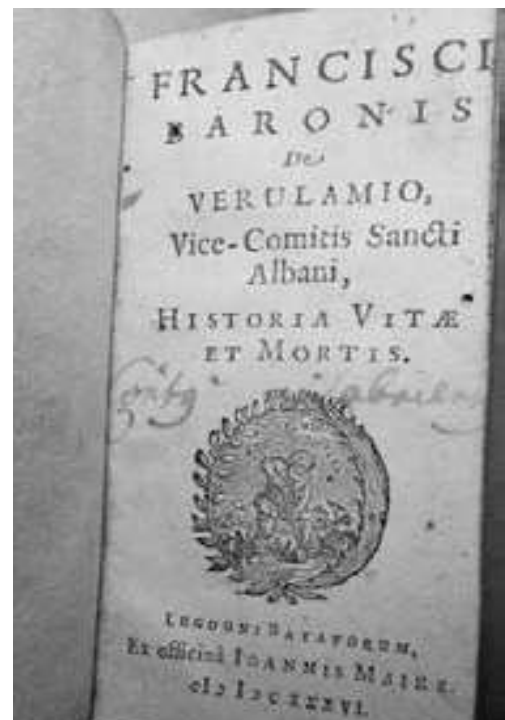

Figure 6-63: The title page of Bacon's book published in Leyden in the year 1636 in the Ljubljana Franciscan Library (Bacon, 1636).

In Leiden the later provincial of Castilian Franciscan province Gaspar de la Fuente (Caspar, * about 1596; OFM; D. 1665) published Scotus' issues of Dialectics and physics with in-depth treatment of the vacuum read by the Ljubljana

Franciscans. As an example, he indicated the water clock (gnomon),⁷⁴⁷ and his key objection against the vacuum was again redeemed by the grave personal problems of flying angels who were supposedly unable to use their wings in vacuum. Fuente noted Burleaus and others against the allies of the Averroes to get rid of the vacuum.⁷⁴⁸

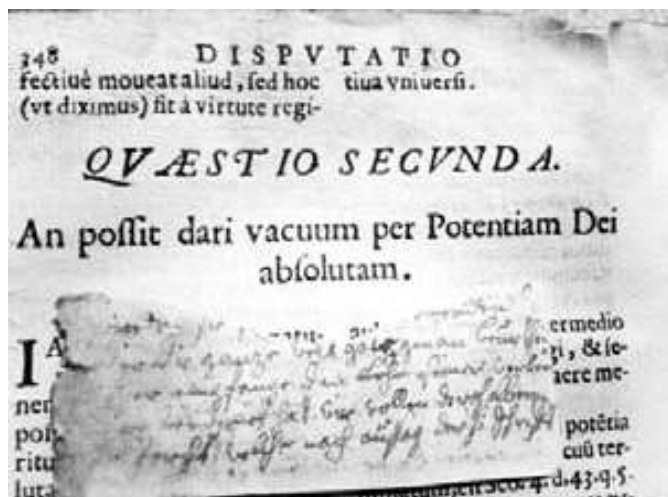

Figure 6-64: Rubeus published in Latin language about the almighty Creation of vacuum with added leaf of notes of Ljubljana reader in German language (Rubeus, 1653, 1:348); F.

The Ljubljana Franciscans have purchased several books of the famous beginner of the contemporary natural sciences Francis Bacon. Bacon was already fully hospitable to vacuum in his small booklet of 1636.⁷⁴⁹ Similarly, Bacon recognized voids in his posthumously issued tiny booklets on winds where the Ljubljana Franciscans read Bacon's praise of Epicurus' Atomism.⁷⁵⁰

Škerpin also acquired the book of Paduan Franciscans Barthol Mastro de Meldula and Bonaventura Belluto Catanensi. Mastro de Meldula and Belluto Catanensi commented Aristotle's books of metaphysics and physics. They accomplished their work on physics in 1644 with a little help of the Archbishop Cardinal Alois Caponio. They tried to measure the relations between the empty vacant spaces and matter in the universe. Their main questions were still the possibilities of translation in vacuum. It's a pity that they did not bother to learn about the barometer which Evangelista Torricelli described

⁷⁴⁷ Fuente, 1631, 646.

⁷⁴⁸ Fuente, 1631, 651.

⁷⁴⁹ Bacon, 1636, 241, 421-422.

⁷⁵⁰ Bacon, 1662, 223-224.

for the first time in his letter to the young future Cardinal Michelangelo Ricci dated on June 13, 1644, in the same year when the Paduan Franciscans published their book.⁷⁵¹



Figure 6-65: The title page of second part of Merinero's Course of Philosophy with the propriety entries of Brenn and Budnović in Ljubljana Franciscan library (Merinero, 1659); F.

The reformer of the Academy Degli Imperati, Barthol Mastro de Meldula (b. 1602; d. 1673) and Franciscan from the Paduan college Bonaventura Belluto Catanensi (* 1599/1600; d. 1676) have published comments to the Aristotelian Books of metaphysics and physics. They published their comment on physics together with the Archbishop Cardinal Alois Caponio in 1644. They described vacuum in the fifth Book of physics between chapters 12.1. and 12.8. They were interested in the relationship between the vacuum and the fullness, but especially in the movement in the vacuum. Of course, they have not yet known the Torricellian barometer which was for the first time

⁷⁵¹ Barthol Mastro de Meldula, Bonaventura Belluto Catanensi, *Physicorum...* Venetiis: Ginammi (FSLJ-10 b 1), 1644, 5: p. 888 (paragraph 12. 1.), p. 898 (Chapter 12. 1.), p. 901 (Chapter 12. 1.).

described in the year of issue of their book.⁷⁵² The excited Ljubljana Augustinians immediately purchased Mastro De Meldula's book without a delay.

On 29. 6. 1725, the Ljubljana Franciscans additionally purchased even the posthumous issue of Barthol Mastro de Meldula's (* 1602 Meldola; OFMconv; † 1673 Meldola) philosophy with physics in three books of giant volumes. On that occasion, the Ljubljana Augustinians couldn't cope with them, because Josef II in the meanwhile suppressed Augustinians' monastery and put Franciscans in it. The greatest range of big book itself did not improve wrong Mastro De Meldula's opinion that vacuum provides no resistance and so also no sequence of movement.⁷⁵³ Alessandro Rubeus quoted his religious co-brother Mastro De Meldula's options for movement in vacuum.⁷⁵⁴ Also Rubeus (Rossi da Lugo) as a Franciscan conventual lecturer in Bologna and Assisi used to be quite certain that the almighty God can create the impossible Vacuum.



Figure 6-66: Title page of Trieu's book in Ljubljana Franciscan library with Blagaj's propriety entry (Du Trieu, 1675); F.

In 1744 Škerpin provided new bindings for many Franciscan books in Ljubljana, among them for the Scotus's philosophy of Madrid Franciscans' lecturer of theology, Joanes Merinero, who got promoted to a bishop of Valladolid in 1647. The Ljubljana Franciscan Lecturer, provincial, and later Bishop in Istria Pavel Budimir previously kept the

⁷⁵² Mastro de Meldula, Belluto Catanensi, 1644, 5:888 (Chapter 12. 1.), 898 (Chapter 12. 1.), 901 (Chapter 12. 1.).
⁷⁵³ Mastro De Meldula, Belluto Catanensi, 1708, 2:324.
⁷⁵⁴ Rubeus (Alessandro Rossi da Lugo) 1653, 352-353.

item in his rooms. Merinero opposed vacuum as the strict follower of Aristotle. For him, and he was not alone at all, the vacuum was in opposition with nature because the bodies were not able to take any move in vacuum as Franciscan Scotus stated many centuries ago. The main Merinero's question was the possibility of progression in the empty space. Is the translation there momentous or it takes considerable time anyway?⁷⁵⁵



Figure 6-67: The title page of Stannarius' System in the Ljubljana Franciscan Library (Stannarius, 1661).

Sixty-fifth General Minister of the Castilian Franciscan Province and former minister general of all Franciscans in 1639-1645, the bishop of Valladolid Joannes Merinero (Juan, * 1600; OFM; died 1663) published comments on eight Aristotelian books of physics with a hefty discussion on the vacuum printed in his domestic Madrid in 1659. Merinero's chief reader was the Ljubljana Franciscan Marci Brenn and after him Paul Budimir (Budnovich), who was among the leading officials in the Ljubljana Monastery during the years 1662-1668. He became the general Definitor and Pičen (*Pedena*) Bishop. Škerpin has bind all four Merinero's volumes with the new semi-hard parchment binding in 1744. Merinero used primarily the works of his countrymen Benedictus Valentin Pererius.⁷⁵⁶ Otherwise, he

⁷⁵⁵ Joan Merinero, 1659, 3: pp. 154, 157-158, 167, 171.
⁷⁵⁶ Merinero, 1659, 177.

behaved similarly antagonistic to the poor Averroes as Merinero's foremost compatriot and associate on the eminent functions of their order, De la Fuente.

In 1661, Gregorius Stannarius (Kangießer, b. 1610 Marburg; d. 1670 Marburg) published *Systema regularum Philosophorum* which the Ljubljana Franciscans read. Stannarius was the Kassel of northern Hesse professor of philosophy and then Marburg Professor of philosophy and theology. He discussed vacuum only briefly, even if the Torricellian barometer was already old news in his times.



Figure 6-68: The spine of Oviedo's work at the Ljubljana Franciscans' library (Oviedo, 1663)

The Ljubljana Franciscans acquired the posthumous philosophical course of Franciscus de Oviedo (* 1602 Madrid; SJ; D. 1651) published in 1663. He cited his Spanish co-brothers, the Jesuits Arriaga and (Gabriel) Vasquez against the vacuum.⁷⁵⁷

The Jesuit from Cambridge Thomas Compton Carleton (*1592 Cambridgeshire; d. 1666 Liège)



Figure 6-69: A dedication picture of Bavarian electoral prince Maximilian in the volume of Carleton alias Compton's philosophy with the physics of vacuum from the Ljubljana Franciscan library (Compton, 1664).

had to teach theology at the English college of Liège instead of his native country, but this gave him the opportunity to dedicate his own bulky philosophy to Bavarian electoral prince Maximilian, of course not for free. Carleton's Disputations did not quite follow the Aristotelian frames. So, he set his 32nd Disputation about the space and vacuum immediately after he finished his second Aristotle's Book of Physics. Carleton felt that the vacuum can be experientially perceived in fantasy spaces outside the universe (Spatia Imaginaria extra coelum Empyreum Dici possint vacuum). It seemed to him that the movement in the vacuum was not necessarily timeless, but the Earth was still his center of the universe. He rejected Descartes including the Cartesian refusal of the vacuum,⁷⁵⁸ which may have been an additional reason to buy Carleton's book for the Library of Ljubljana Franciscans. The

⁷⁵⁷ Oviedo, 1663, 324.

⁷⁵⁸ Compton, 1664, 332-334.

system of Tycho Brahe and Clavius with the fluid universe seemed to be the best for Carleton's clarification with the telescopic images of sunspots.⁷⁵⁹ Carleton felt no need to specially note Galileo, Torricelli or Copernicus who were not specifically highlighted. The Ljubljana Franciscans also read Compton's theological books.

The Franciscan John Punch published similar opinions about vacuum like Compton but Punch disliked vacuum even more. His Ljubljana co-brothers read Punch's work in two different editions. Punch studied in Leuven and Cologne. He participated in the editing process of Scotus' collected works. In 1630 he became Chancellor-rector of the Roman *Collegio Ludovisano*, and in 1648 he returned to Paris.



Figure 6-70: The title page of the newer and larger among Poncius' (Ponce) books at Ljubljana Franciscans' library (Poncius, 1672). The Irish Observant John Punch (Pontius) quarrelled with the Conventual Bartholomew Mastrius and his collaborator Bonaventure Belluti because they were the members of the different independent branches of Friars Minors and Punch was not so strict follower of their common teacher Scotus. The Ljubljana Friars Minor Observants acquired books of both quarreling parties even if they sided by their own John Punch

⁷⁵⁹ Compton, 1664, 398, 400.

The older Roman Imprint of Punch's (Poncius) Philosophy issued in 1642-1643 was also purchased in Ljubljana. Its happy erudite owner was Johann Baptist de Presheren von Heldenfeld probably the lay brother Ivo Prešeren. He was the ancestor of Janez Prešeren von Heldenfeld and his son Janez Prešeren von Heldenfeld (* Lesce in Gorenjska; d. 17. 6. 1814 parish Brezovica), the husband of Maria Prešeren (* 12. 11. 1837). He was the ancestor of Joseph Mathias Prešeren von Heldenfeld of Radovljica, who defended the philosophical-theological examination thesis in connection with the vacuum in the class of professor Janez Baptist Mayr in Ljubljana in 1728.⁷⁶⁰ Both editions of the work of Punch (Poncius) were likely the same, except that the earlier Roman edition used 22 cm tall octavo format divided into three volumes while the later Leyden printer published in much taller 37 cm folio format. Punch (Poncius) argued that in nature the vacuum is not possible. Anyway, according to the influential book of Madrid experts (Complutensibus, Universidad Complutense de Madrid), Punch (Poncius) believed in a miraculous creation of vacuum needed even for angels' flights.⁷⁶¹ Specifically, Punch (Poncius) thought about the possibilities for movement in the vacuum regarding the stone that's thrown from the moon towards the earth. If there is a vacuum in between, the movement of the stone would have to happen momentous. Similarly, the ray from the sun would come to us momentously, as it would not have encountered any resistance in the vacuum in-between.⁷⁶²

Philippe du Trieu lectured about the philosophy in Douai. In 1716, Sigismund Anton Joseph Ursini Count of Blagaj (b. 1686) bought his posthumous separately paginated booklet about Physics printed in the year 1670 bound to Treu's logic and dialectic issued in the year 1675. Trieu has described the vacuum,⁷⁶³ but he died too soon to mention the just invented barometer.

In 1669 in Leyden the father Bonaventura Columbus (Columbi, * 17th century in Nice; OFMconv) published a complete course of Scotus' philosophy in a weighty book that you could barely

⁷⁶⁰ Mayr (Mayer), Presheren, 1728 (FSLJ-5 D 21).

⁷⁶¹ Poncius (Punch), 1672, 557, 559; Poncius (Punch), 1642, 479, 484.

⁷⁶² Poncius, 1672, 562; Poncius, 1642, 493-494.

⁷⁶³ Trieu, 1670, 2:44.

lift on, let alone read. He was profoundly inspired by his religious co-brothers Barthol Mastrio de Meldula and Bonaventura Belluto Catanensi. Columbus devoted some of his hefty pages to the vacuum in Aristotelian and Scotus' spirit of his days. As it was fit for a Franciscan, after dialectic and a rational philosophy, he embarked on the philosophy of nature or physics and described in the third question of his sixth book the problems of the vacuum in frames of Aristotle's fourth book of Physics. Of course, he supported Aristotelian criticism of Pythagoras' fans with the nature which is afraid of the vacuum.⁷⁶⁴ He mentioned Mayr, Bonet's translation of Rohault's physics and Magistris de Montis' (Regiomontanus') Incunabula, which was also purchased by Ljubljana Franciscans. Columbus was really very funny in his discussions of the possibilities for the flight of chubby angels in the vacuum.⁷⁶⁵ Nonetheless, the will of God's almighty allowed a vacuum with us and above the moon, but Columbus forgot to mention a quarter-century old barometer and vacuum pump.

The Franciscan Livio Rabeanus da Montursio of Vicenza (b. 1605; d. 1664) criticized Pythagoras' description of the vacuum in his posthumous edition of 1665.⁷⁶⁶ Montursio's book was used in Trsat above Rijeka by Peter Francetić who used to be a general lector, former provincial, three times definitor, general commissary and visitor of Franciscan provinces of St. Ladislaus in Slavonia, St. Savior in Hungary, St. Leopold in Tyrol, and St. Venceslaus in Bohemia. Later, the Montursio's book was placed in the library of Ljubljana Franciscans. In Ljubljana, Pavel Budimir also used the same edition bind to the physics issued in 1664. Rabeanus da Montursio discussed the results of the Jesuits from Coimbra, Ruvius (Antonio Rubio), as well as Fuentes and Poncius who were also read in the Ljubljana Franciscan Library.⁷⁶⁷ Rabeanus de Montursio already supported the placeable position by which God can make weird things, including even a strange vacuum.⁷⁶⁸

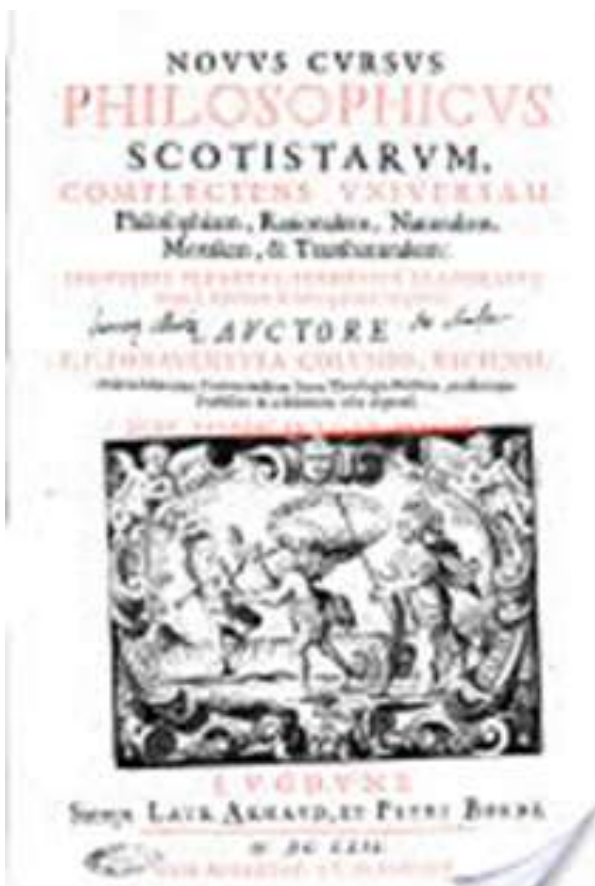

Figure 6-71: The title page of Columbus' discussions on philosophy, physics and Vacuum from the year 1669.



Figure 6-72: The title page Regiomontanus' incunabula from 1490, cited by Columbus in 1669.

The Spanish professor of theology in Florence the Franciscan Thomà Llamazares published two questions about the nature and the movement in the

⁷⁶⁴ Columbus, 1669, 469.

⁷⁶⁵ Columbus, 1669, 470-471, 473.

⁷⁶⁶ Montursio, 1665, 431.

⁷⁶⁷ Montursio, 1665, 435.

⁷⁶⁸ Montursio, 1665, 439.

vacuum; the latter was again primarily focused on the problematic flying of angels.⁷⁶⁹ Certainly, Škerpin immediately acquired that book during his visits in Spain to check those angels' abilities in person.

In 1670 the professor in Padua the Somascan father Francisco Caro described and drew the operation of Baroscope filled with mercury.⁷⁷⁰ He even mentioned the new pneumatic vacuum pumps of those times.⁷⁷¹



Figure 6-73: The title page of Sichen's philosophy and physics with a fair nice contemporary presentation of the vacuum. It has a cutoff emblem of Antwerp native printer Beller (Balthasar Bellère. 1564-1639 Douai) and the original bookplate of Franciscan library in Kircher's home Fulda of 1671. Later, it was acquired for the Franciscans' library of Ljubljana (Sichen, 1666).

In Leuven, the professor Willem Van Sichen (Guillaume, * 1632; OFM; D. 1691) initially taught philosophy, and then he advanced as the professor of theology according to the ideas of scholarly statuses of those times. In 1671 at the ancient University of Leuven he gave his students of theology his exam questions. They publicly

⁷⁶⁹ Llamazares, 1670, 243-246.
⁷⁷⁰ Mocenici, 1670, 167.
⁷⁷¹ Mocenici, 1670, 169.

defended his thesis on vacuum where he dealt with the new Oviedo's work, which was also read by the Ljubljana Franciscans. The Franciscan Sichen wrote his textbook for his religious co-brothers' lessons. He did not like Cartesians, but he still accepted some Descartes' ideas in physics, mostly because Sichen updated the teachings of his religious co-brother Scotus much more successfully compared to Mastro de Meldula or Belluto. Sichen praised Kircher's description of the dilution of the atmosphere at the peaks of Peru, Chile and the Greek Olympus,⁷⁷² but not without the mention of Kircher's critics from Galilean circles. Even if Kircher used to be a clever guy, he was a Jesuit anyway and therefore archenemy of the Franciscan Sichen. Sichen's book was initially owned by the monks Franciscans in Fulda. The Friars minors of Fulda probably bound their slightly narrower leaves full of the examination questions of two Sichen's students of theology in Leuven. They pasted them flat against the inside of endpaper of back cover of the book.



Figure 6-74: Sichen's introductory treatment of vacuum with nicely designed initial (drop cap) of a chapter (Sichen, 1666, 2:100).

In his debate about space and time the Roman Professor Andreas Semery Remus (b. 1630; SJ; D. 1717) dealt with the vacuum and possibilities for

⁷⁷² Sichen, 1666, 2: 100-, 106 Right column.

movement in it following the ideas of Aristotle and St. Thomas.⁷⁷³ Although Semery also described experiments,⁷⁷⁴ among them we in vain search for Torricellian (1643) and Guericke's investigations of 1654. Several times Semery stated the thoughts of Valeriano Magni on the visual display of the vacuum.⁷⁷⁵ That Capuchin Magni has been a real painful thorn in the heel of the Jesuits. In his last discussion of the second year, Semery dealt with the Aristotelian book of the Sky, and in the first debate of the third year (Triennium Philosophicum / 2, Annus Secundus) Semery discussed the Aristotelian books on the formation and decay. Then, Semery focused on the areas that today belong to philosophy and theology.

In 1672, the Istanbul Franciscan nuncio (vicar patriarch) appointed in 1638 Angelus Petricca (Petricca de Sonneno, *1601 Sonnino in Central Italy of then Campagna e Marittima; OFMconv; D. 1650 or 1673 Roma) posthumously published a triple Aristotelian philosophy in which, of course, there was no lack of a description of the vacuum with a nice handy conjecture that Almighty God could create an otherwise impossible vacuum.⁷⁷⁶ Petricca was a great unionist Christian activist of ecumenism in Ottoman regions which gave a special favor to his physics.

From his extended travels, Škerpin brought to Ljubljana an interesting posthumous presentation of the "negative" philosophy of the Jesuit Antonius Forti (* 1651 Caltagirone in Sicily; SJ; D. 1707 Palermo). Forti dedicated his third and fourth books to physics among his five books. Forti discussed the possibilities of vacuum focused on belief that the empty space is maintained. In the description of the movement, Forti quoted Aristotle as well as the mercury barometer. Forti recommended the work of his religious co-brother Paulo Casati, who was very popular in Inner Austria and in Ljubljana. Forti, of course, was gravely upset by the omnipresent angels waving their wings in vain in an empty space;⁷⁷⁷ unfortunately, he didn't think of the possibility of

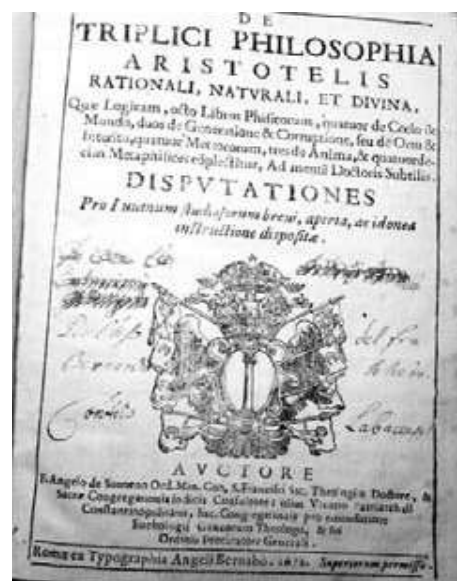
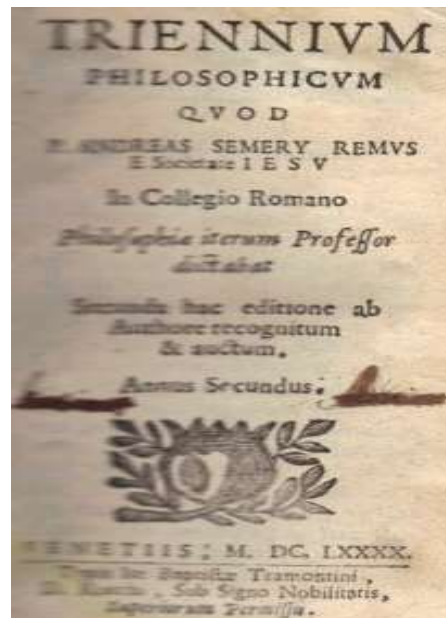

Figure 6-75: The title page of the Semery's textbook at Ljubljana Franciscans' library (Semery, 1690) and the title page of Ljubljana Franciscan book of Angelo da Petricca De triplici philosophia Aristotelis rationali, naturali, et divina, quæ logicam, octo libros phisicorum, quatuor de cælo & mundo, duos de generatione & corruptione, seu de ortu & interitu, quatuor meteororum, tres de anima, & quatuordecim metaphisices complectitur, ad mentem doctoris subtilis. Disputationes pro juvenum studiosorum brevi, aperta, ac idonea instructione dispositæ. Auctore F. Angelo de Sonneno, ord. Min. con, S. Francisci sac. theologiæ doctore, & Sacræ Congregationis indicis consultore; olim vicario patriarchali Constantinopolitano, Sac. Congregationis pro emendatione euehologii Græcorum theologo, & sui ordinis procuratore generali, Rome: Angelo Bernabò, F.

⁷⁷³ Semery, 1708, 2:525, 539 (7. Discussion of space and time, sixth chapter).

⁷⁷⁴ Semery, *ibid*, 1708, p. 528.

⁷⁷⁵ Semery, 1690, 558, 561.

⁷⁷⁶ Petricca de Sonneno, 1672, 159-160.

⁷⁷⁷ Forts, 1744, 2:636, 638, 639, 641.

their reactive propelled rocket drives which was strange as the rocket itself used Italian name *rocchetto*. The first gunpowder-powered rockets evolved in medieval China under the Song dynasty of the 13th century and soon spread among Bavarian, Polish and Habsburgian military engineers after the Padua court physician Konrad von Kyeser⁷⁷⁸ wrote his nicely illustrated *Belli Fortis* full of alchemistic and magic visions to misguide the enemy in 1402-1405. Konrad wrote down his ideas during his spare times when Barbara's imperial husband exiled him from Prague to the Bohemian mountains Burg Žebrák (Bettlern) and maybe also to his hometown of Bavarian Eichstätt north of Munich and Ingolstadt. Kyeser's magic novelties failed to distinguish himself during the Barbara's husband and father's lost battle of Nicopolis in 1396 which made Kyeser quite unpopular.⁷⁷⁹

The Ljubljana Franciscans were also fond of reading another Jesuit opponent of the vacuum, the Italian Jesuit Mauro, who was a professor of philosophy and an occasional rector of the Roman College since 1653 until his death. In the years 1654/55 and 1657/58 he taught physics.⁷⁸⁰ He represented the ideas of St. Thomas Aquinas in Suárez' version. In his five books of philosophical issues, he introduced a very clear overview of Aristotle's work and developed the findings of his interpreters from the thirteenth century. The reading of Ancient Greek records has been complemented by the best Latin translations of his days. Stična monks read an early edition of Mauro's philosophy. The first Carniolan vacuumist Janez Vajkard and his brother Volf Engelbert Auersperg (Turjak) besides the later edition of that Mauro's work also purchased Mauro's interpretation of Aristotle, which found its ways into the libraries of the Ljubljana Franciscans and Škofja Loka Friars Minor Capuchins. Mauro has denied a vacuum despite Democritus, Leucippus and Anaxagoras. According to Pythagoras' fans and Plato's admirers, Mauro argued that the vacuum is not a material item, even if it enables condensation in parts of the body. Mauro recognized the steady movement in the vacuum under the influence of gravitational force but

discouraged the vacuum wellbeing in the universe.⁷⁸¹ In his pocket edition printed two years later he described more specifically the experiments with mercury following his religious co-brother, the Jesuit Paul Casati.⁷⁸² In particular, he discussed possible vacuum flights of the naughty omnipresent angels.⁷⁸³

The French Dominican magister Niccolò Arnù (Arnu, B. 1629 Béziers; d. 1692) was a public professor of theology in Padua slightly before G. Tartini and Carli's times. Arnù wrote about the unmoved mover or prime mover ($\delta\ \text{o}\acute{\upsilon}\ \text{k}\iota\text{n}\acute{\omicron}\mu\epsilon\text{n}\omicron\nu\ \text{k}\iota\text{v}\epsilon\acute{\iota}$, *primum movens*), as well as on the theology. His book of 1685 was purchased in Ljubljana in 1726, but it probably did not belong to Škerpin's collection because it has a inscription on a bookplate over the title page without Škerpin's bookplate sticker. For the additional readings, the Franciscans of Ljubljana purchased a decade later Arnù's mathematical philosophy. The third volume of the book has dealt with eight (Aristotelian) physical books. With its own pagination, Arnù attached his second part of the third book focused on five subsequent Aristotelian books including *Parva Naturalia*. Arnù described the vacuum in his special query number 2 with two article (*Articulus*) twenty pages long. First, Arnù thought about Greek and Latin (*Inane*) term for a vacuum and quoted Lucretius' claim that the bodies are in the vacuum. By the compilations of classical author Stobaeus' (Ἰωάννης ὁ Στοβαῖος) from the Macedonian Stobi (Στόβοι, Стоби) *Eccl. Phys.* (Eclogues, Ἐκλογαὶ φυσικαὶ καὶ ἠθικαὶ) Arnù compared Cleomedes' (Κλεομήδης) vacuum to nobody. The vacuum was supposed to take over the pores, but Aristotle opposed any claims like that, while Epicurus, Leucippus, Gassendi and Joannes van Helmont have rejected Aristotle. Again, it seemed otherwise to Plutarch, Plato, Melisus or Eleatics Pre-Socratics. Arnù, of course, also discussed the performance of the popular pumps, where the seals prevented the return of the extracted air. Arnù reported Gassendi's opinion about them, and there were very eloquent Ctesibius' (Κτεςίβιος, Tesibius, Κτησίβιος; fl. 285–222 BC) *Ctesibianis* over two millennia old pneumatic pumps which they called *Pompe* while the Italians called them *Selo*. For their pumping of

⁷⁷⁸ Konrad Kyeser (Conrad Keyser).

⁷⁷⁹ Benedek Láng. 2010. *Unlocked Books: Manuscripts of Learned Magic in the Medieval Libraries of Central Europe*. Penn State Press, 211-212.

⁷⁸⁰ Villoslada, 1954, 330; Blum, 2002, 375.

⁷⁸¹ Mauro, 1668, 3:109-113, 4:736, 6:594.

⁷⁸² Mauro, 1670, 519.

⁷⁸³ Mauro, 1670, 537.

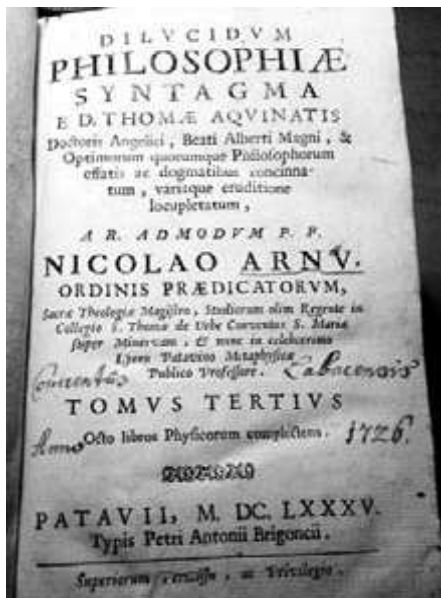

Figure 6-76: The title page of the Arnus's philosophy of the year 1685 purchased for Ljubljana Franciscans' library in 1726 (Arnus, 1685).

air upwards, they used mercury instead of water. Other pumps extracted water, and a special case was a water clock *klepsydra* with the axis (Kardan) used for pumping. Arnus compared the pumping process with the recently discovered (Harvey's) blood circulation. Of course, Arnus quoted Aristotle, as well as the impact of fire, demonic elements of the world and the possibility of moving angels in a vacuum. The vacuum should oppose the good regulation of the world, as indicated by the mechanism of clock. Arnus then embarked on the rejection of the opposing claims as absurd based on Aristotelian arguments, the claim of St. Thomas, Cicero and Seneca. Arnus summed up the behavior of mercury and described its partial evaporation according to the citations from the works of Albert the Great. In his second composition (*Articulus*) Arnus focused the opinions of the Constantinople imperial public speaker Themistus (* 317 Paphlagonia; † around 390), Aristoteles' commentator Simplicius (Σιμπλικίος ὁ Κίλιξ; c. 490 – c. 56), Burleaus, the Augustinian Aegidius (Egidio Romano, * around 1243; d. 1316) as a disciple of St. Thomas Aquinas at the Parisian Faculty of Philosophy, Jandanus (of Prerugia?), the Viennese rector Albert of Saxony (ca. 1320–1390), the critics of magics of cabala and Clavius' promotions of mathematic curricula Benedictus Pererius (Valentin, * 1535 Ruzafa near Valencia; SJ; D. 1610 Rome) and many other ideas about the movement in the empty. He also cited the

Madrid experts (Complutenses, Universidad Complutense de Madrid) and St. Thomas's ideas about the center of the sky. Like Burleaus before him, Arnus specifically disregarded the possibilities for movement between points A and B in the vacuum and finally solved the arguments with the assertion that the vacuum could not be, especially not in St. Thomas' networks.⁷⁸⁴

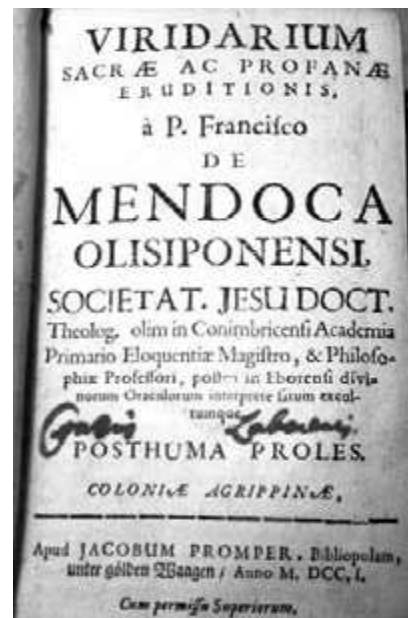

Figure 6-77: The title page of the Mendoca's book from the year 1701 in Ljubljana Franciscans' library (Mendoca, 1701).

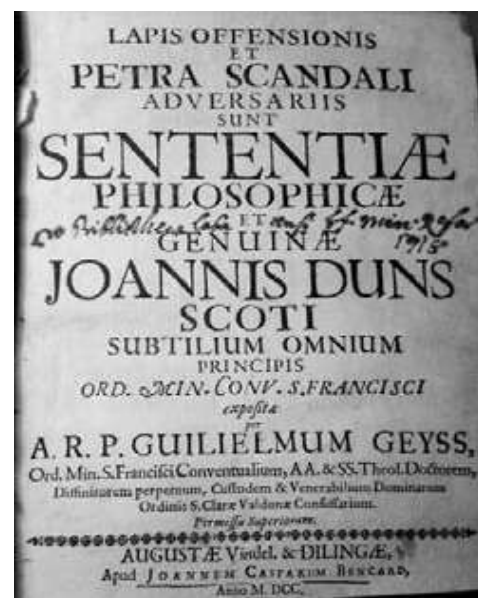

Figure 6-78: The title page of Geys's adaptations of Scotus' philosophy against the vacuum (Geys, 1700); F.

⁷⁸⁴ Arnus, 1685, 3/2:134-153.

In 1701 in Cologne appeared the Jesuit Francisco Mendoca's posthumous *Flowers from different gardens*. Among his philosophical flowers, he scorned the Copernicans with the fans of Pythagoras, Caelius Calcagninus and Augustinian Hermit Diego de Zúñiga of Salamanca included.⁷⁸⁵ Copernicus and Zúñiga's books were on Papal index which put Mendoca in the safe side. His center of gravity rested in the center of the universe, as it was highly appropriate by Papal decree. Mendoca considered his chances to fly in the air.⁷⁸⁶ He would even flutter to the moon during his thoughts about the nature of the fire and the resistance of the gliding vessels full of air or water.

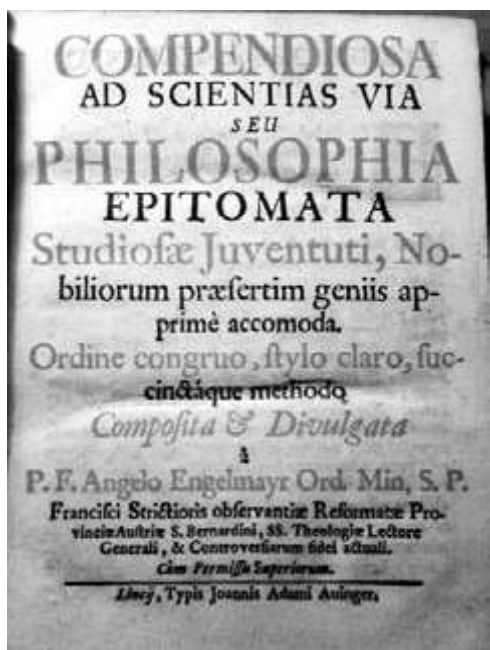

Figure 6-79: The title page of the Franciscan Engelmayr's textbook of Physics in Ljubljana Franciscans' library (Engelmayr, 1738).

The Friar Minor Conventual (Minorite) Wilhelm Geys published a philosophy that was purchased by his Ljubljana religious co-brothers eighteen years later. He was not particularly fond of the vacuum. Against the dilution as a removal of the substance, Geys used the ideas of Scotus as well as the century old work of Peter Tartareti and his religious co-brother Philipp Faber, which were also read by Ljubljana Franciscans.⁷⁸⁷

The Franciscan professor of theology Angelus Engelmayr drew a pleasant philosophical textbook

⁷⁸⁵ Mendoca, 1701, 309.

⁷⁸⁶ Mendoca, 1701, 315.

⁷⁸⁷ Geys, 1700, 266-267

for his disciples in Linz, which Škerpin got for his Ljubljana monastery. Engelmayr's disliked vacuum. Of course, Engelmayr cited against vacuum mostly Cartesian example of emptying the cup full of wine. Engelmayr even quoted the theological writers,⁷⁸⁸ of course, not his own opponents. Engelmayr was guardian in 1735; he published his theological books in Trnava and Košice in 1738-1770.

6.5.4 Ljubljana Franciscans in Favor of Vacuum

Soon after Valvasor's death the Ljubljana Franciscan reading about the vacuum experienced a real turnaround after which they started their regular acquisitions of the books about experiments with vacuum and even illustrated



Figure 6-80: Title page of Viviani's geometry; he was the last Galileo's pupil and as the first assembled the barometer by Torricellian instructions.

⁷⁸⁸ Engelmayr, 1738, 199-203.

them in their domestic manuscript textbooks. In such a new era the works of Cornaeus (1657), Donatus (1754), Zanchi (1754), Georg Friederich Brander (1772), Biwald (1774) or Metzburg (1791) were immediately purchased by Ljubljana Franciscans, even if they used only mathematical works of Cornaeus' collaborator Schott and did not buy the books of more famous Schott's teacher Kircher at all. Galilean original records were avoided because of Papal threats, so they read the geometry of Galileo's last pupil V. Viviani, who first assembled the barometer after the Torricellian instructions. Of course, many books of Ljubljana Franciscans' library used to favor Galileo's ideas as well as Riccioli's explanation of the weight of air.⁷⁸⁹



Figure 6-81: Viviani's sketch in the Ljubljana Franciscan Library (Viviani, 1746, 152).

Besides Cornaeus and Weber, the Ljubljana Franciscans and other Carniolan erudite also purchased Doreguzzius' (Natale Doregucci) book issued in 1682. Doregucci's publication was a reprint of the famous textbook of the first president of Parisian academy Du Hamel and the son of his patron the minister Colbert. The first three volumes of logic and metaphysics were published in Paris in 1678, but the entire work of six volumes divided in two books first appeared in Nurnberg in 1681. Volumes four and five focused the general physics, while the last volume six contained the third part

⁷⁸⁹ Weber, 1677, 62.



Figure 6-82: Johann Adam Weber praised Galileo and Riccioli's experiments proving the weight of air in his book kept at the library of Ljubljana Franciscans (Weber, 1677, 62). Johann Adam Weber (1611-1695) was never a Jesuit priest according to Jesuitical sources. Weber was an Augustinian professor first in Neustift in the territorial districts of Bressanone, later in Augsburg in Heiligenkreuz in 1673. Most recently Weber served as a provost of the Augustinian monastery Hegelwerth in Salzburg in 1686-1691. He also served in Augustinian monastery Neuburg in Lower Austria in the famous abbey Klosterneuburg. The Capuchins of Škofja Loka acquired several Weber's books while the number of his works in modern Slovenian libraries exceeds two dozen which made Weber one of the chief protagonists of modern new science in Carniola after the Thirty Years War. The other younger Johann Adam Weber was professor in Altenburg Grammar School in Saxony in 1745.

of physics. Du Hamel, Colbert and Doregucci were the early vacuum advocates of 1682, which was no wonder after Huygens' experiments performed in front of Parisian academy. Doregucci dedicated some of his writings to his high society friends Paolo Scipione Pelloni and Carl'Antonio Del Frate. Du Hamel and Doregucci dedicated to the vacuum and images of its experimental investigations forty pages of a small format in the last five chapters of the second tractate of the fourth book on physics with separate pagination in Doregucci's edition but not in Du Hamel's. They knew that nature was not afraid of a vacuum, which made voids possible.⁷⁹⁰ Initially, Du Hamel and Doregucci described and

⁷⁹⁰ Doreguzzius (Doregucci), Hamel, 1682, 349.

drew a Boyle's pump. Doregucci used Du Hamel's title in the same year 1682. The Franciscans of Ljubljana acquired Du Hamel-Colbert's edition of those books in the later edition of 1730-1736, while later edition issued under Doregucci's name is also kept in NUK.

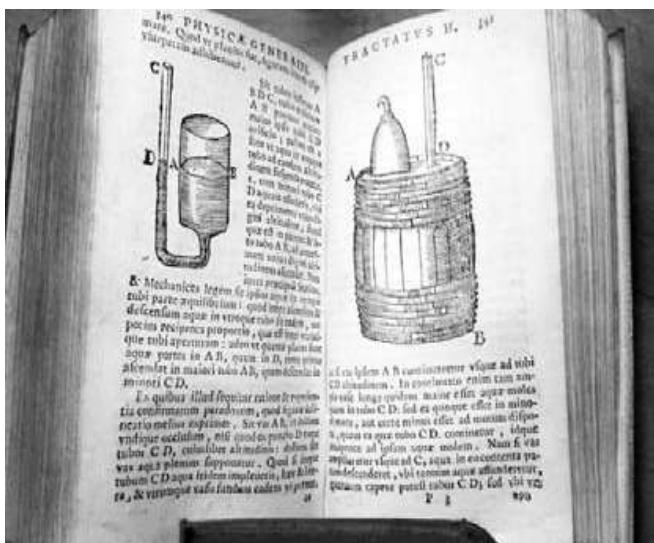

Figure 6-83: The page of the Doreguzzius' book dedicated to hydrostatics (Doreguzzius, 1682, 4: 340). The same pages with pictures were published in Du Hamel's work (Du Hamel, 1682, 4/2: 207-208)

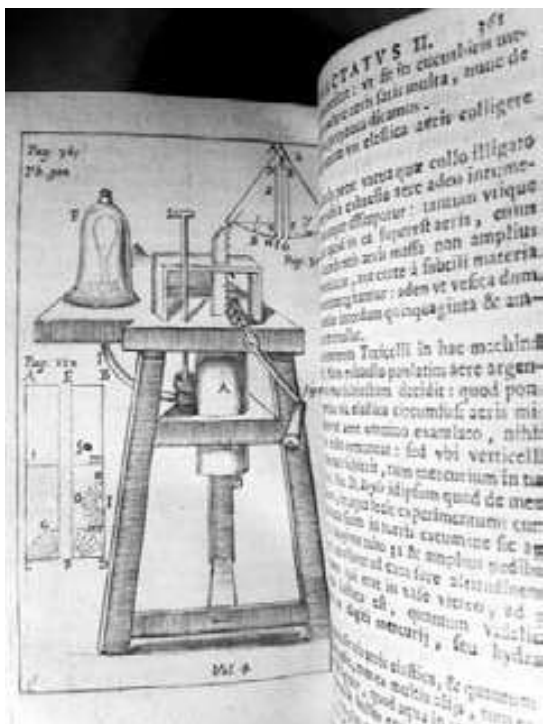

Figure 6-84: Boyle's pump in the Franciscan Ljubljana book (Doreguzzius, 1682, 4: 360/361). The same page with picture was published in Du Hamel's work (Du Hamel, 1682, 4/2: 219)



Figure 6-85: Doreguzzius' comparison of the work of heart, arteries and veins with hydraulic vessels of W. Harvey's type in the Franciscan Ljubljana book (Doreguzzius, 1682, 6: 151 pictures for page 310). The same page with picture was published in Du Hamel's work (Du Hamel, 1682, 6: 747)



Figure 6-86: Doreguzzius on barometer and vacuum in the Franciscan Ljubljana book (Doreguzzius, 1682, 375). The same page with picture was published in Du Hamel's work (Du Hamel, 1682, 4/2: 229)



Figure 6-87: The title page of the Du Hamel's physics (du Hamel, 1681).

Ljubljana Franciscans read the Nurnberg physics of John Baptist du Hamel, who became a first permanent secretary of the Parisian Academy in 1666. He was among those experts whose books Gruber got for his department of Mechanics in Ljubljana. Du Hamel dedicated to vacuum the eighth chapter of the first part of his book according to Democritus, Cartesians and Gassendi who defined vacuum by the help of atoms.⁷⁹¹ In his second part, du Hamel published sketches of barometers and described the hydrostatic paradoxes of the Jesuit Honorat Fabri (Fabry).⁷⁹²

Du Hamel discussed Helmont's exploration of gases, Hooke's *Micrography*, Guericke's Magdeburg experiments with a vacuum and Boyle's pneumatic machine that has buried peripatetic physics.

Du Hamel was interested in the weight of air, so he described the Torricelli's experiment with mercury, syphon and Boyle's pneumatic pump with Fabry's interpretation, since Fabry reported of the experiment of the engineer Fabricio Guastafarro with a tube full of mercury.⁷⁹³ Du Hamel has described Boyle's observation of the

⁷⁹¹ Hamel, 1681, 1:651-653, 656.

⁷⁹² Hamel, 1681, 2:47, 230.

⁷⁹³ Hamel, 1681, 2:53-54, 232, 233, 235, 236; Fabri, 1669, 646.

(phosphorescent) Bologna stone. He used Boyle's explanation of the colors and Hooke's *Micrography*, because Du Hamel was not yet aware of the importance of Newton's prismatic and thin films optics published a decade earlier.⁷⁹⁴

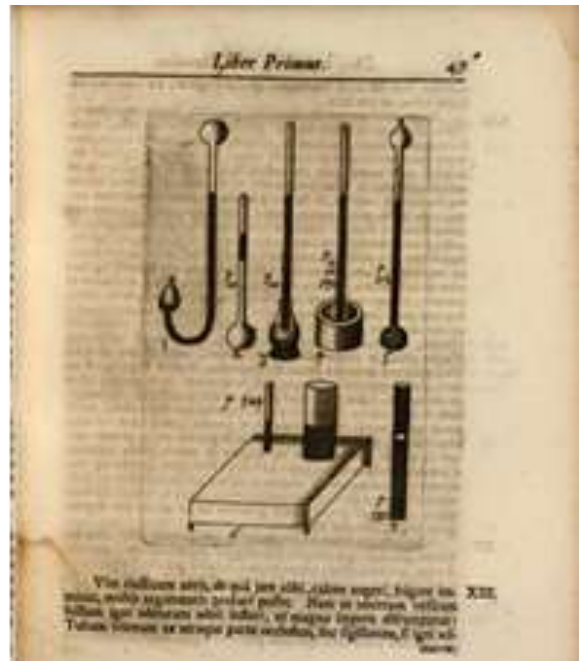

Figure 6-88: Sketches of barometers in du Hamel's physics (du Hamel, 1681, 2:47)



Figure 6-89: Jožef Stefan's mentor Marian Koller pictured Torricellian barometer while he was preparing his lectures (Koller manuscript 15a: 252). Foto: A. Kraml.47).

⁷⁹⁴ Hamel, 1681, 2:104, 106, 118, 121.



Figure 6-90): The title page of the Boyvin's book at Ljubljana Franciscans' library (Boyvin, 1681)

The lecturer in philosophy and Theology at the Normandy Franciscan school Jean Gabriel Boyvin (b. 1605 Vire in Normandy; OFMobs; D. 1681 Vire) wrote about the vacuum, the nature of the forces and the troublesome jumps of flying angels through vacuum. For Boyvin, vacuum was potentially possible, despite of Aristotle's arguments against Pythagoras' and Epicure's infinite vacuums between atoms of metals and rocks. According to Aristotle Horror Vacui the Aristotelian local movement should be problematic. The fluid air takes less space. Boyvin quoted the objection of Duns Scotus against the possible declining power of angels in the empty space (*Potestatem Angelica non Test Procurari vacuum*). The movement in the vacuum is continuous and successive although due to the absent resistance of the media there is no delay or the retardation of motion.⁷⁹⁹ Boyvin quoted the Jesuits Franciscus Suarez (Suárez, Suares, 1548 Granada-1617 Lisbon), the professors from

Coimbra (Coimbricensis), and Rodrigo de Arriaga (1592-1667 Prague) about the new imaginary worlds. God can create thousands of worlds, like a poet narrated,⁷⁹⁵ therefore there is no problem for a God to create a vacuum or two of them.



Figure 6-91: : Illustration explaining the discussions of Aristotelian Materia Prima at Gottscheer's military scholastic book with a description of the vacuum (Gottseer, Krassnigg, 1690,73).

The Polish Jesuit, Persian Isfahan missionary, and Suarez's fan Thomas Młodzianowski (Tomasz Młodzianowski, 1622 Ciechanów (Zichenau)-1686 Wolbrom (Wolfram) near Krakow) belonged to Mazovian Yeomanry (drobna szlachta). He spoke on the coronation of Jan III Sobieski in 1674. He published most of his theological and philosophical books in Mainz. Młodzianowski added his discussion about vacuum to the very end of his philosophical book, exceptionally even after the chapters about time. The Franciscan Ludvik Gallenfels loved to read that book in Ljubljana. Młodzianowski declared the vacuum as the negation of matter, but the vacuum is nonetheless created by the God despite of the intentions of nature which echoed Młodzianowski's eastern ideas endorsed during his missionary activities in Persian Isfahan from 1654 to 1656. Młodzianowski cited the Jesuits Arriaga, F. Suarez and (Gabriel)

⁷⁹⁵ Boyvin, 1681, 1:318, 319.

Vasquez⁷⁹⁶ who were not the fans of the vacuum. Franciscus de Ovieda provided the similar citations in his book which was also read by Ljubljana Franciscans and Mlodzianowski cited Ovieda's visions of the resistance to motions. Mlodzianowski cited the contradictory opinions of the theologian from universities of Rome, Alcalá de Henares and Salamanca Thomás Hurtado (1570 Toledo-1649), F. Suarez and Arriaga about the mixings of gases with solid matter, like the mixing of air with the earth. Arriaga believed the Stoics that the air above the areas of the clear part of sky evaporates to vacuum,⁷⁹⁷ which is not far from modern visions except that Arriaga probably did not consider the dilution of air with the height.

Martin Gottscheer (Gottseer, * 1648 Warth in Upper Austria; SJ 1668 Leoben; D. 1731 Graz) was of Slovenian descent from Kočevje, but in the lack of domestic higher education institutions he taught philosophy with physics at the Graz Jesuit University. In 1690, Karl Josephus Taucher (Jožef Tavčar) from Graz and the Styrian Janez Jurij Krasnik (Joann Georg Krassnigg) carried out a philosophical examination for the lowest academic degree baccalaureate in Gottseer's class. Jožef Tavčar was discussing Carthusians, while Janez Jurij Krasnik published a Gottseer's speculation about Aristotelianism applied to the military science. Janez Jurij Krasnik dedicated the writing of his teacher Gottseer to his benefactors, the five counts of Lamberg from Ortnek, although their manor Ortnek was already sold before those times. Janez Jurij Krasnik praised the talent of Melhior's brother Sigismund Lamberg.⁷⁹⁸ In fact, he followed the chapters of the Aristotelian Books of logic, physics, the World and the sky and the souls. Each Scholastic chapter has been supplemented by a chapter on related military know-how with a total of ten images. Gottseer described vacuum as a place without bodies, which is not present in Nature. Nevertheless, two bodies pressed to one another could eliminate the air between each other to establish a vacuum; almost two centuries later J. Stefan proved that it never happens, but Stefan was already able to provide many other proofs for the funny existence of vacuum. Gottseer's visible

agents cannot empty the vacuum in nature. The weight and lightness are caused by movement: because in a vacuum there is no resistance to the motion, the movement in a vacuum is not possible, at least such were the naïve thoughts of Gottseer.⁷⁹⁹



Figure 6-92: Picture before the title page of Gottscheer's military scholastic book with a description of the vacuum (Gottseer, Krassnigg, 1690).

The canon in Würzburg Joannes Zahn (b. 1633 Karlstadt; d. 1707) was member of the order of Premonstratensians founded by Saint Norbert of Xanten (Gennep, c. 1075 Xanten-Magdeburg-1134), the son of Heribert Count Geneppe. Joannes Zahn has published such a gigantic beautiful book that would be a real miracle if Škerpin would not have bought it. Zahn became professor of mathematics at Würzburg University, the canon and the abbot of Premonstratensian monks between 1685-1707. He used the camera with mirrors that Johann Sturm developed in 1676. He put both concave and convex lenses in the camera Obscura with a telescope, just like a dozen years earlier Zahn already described in his beautifully illustrated book *Oculus Artificialis Teledioptricus Sive Telescopium* published in Würzburg in 1685.

⁷⁹⁶ Mlodzianowski, 1682, 2/1: 378, 394 in unpagged conclusion of book.

⁷⁹⁷ Aer secundae regionis serenissimum, consequenter illis exhalationibus vacuum (Mlodzianowski, 1682, 2/2: 104, 113-114.

⁷⁹⁸ Gottseer, 1690, 121.

⁷⁹⁹ Gottseer, 1690, 117-118.



Figure 6-93: Picture before the title page of Zahn's book in the Ljubljana Franciscan Library (Zahn, 1696, 1:).

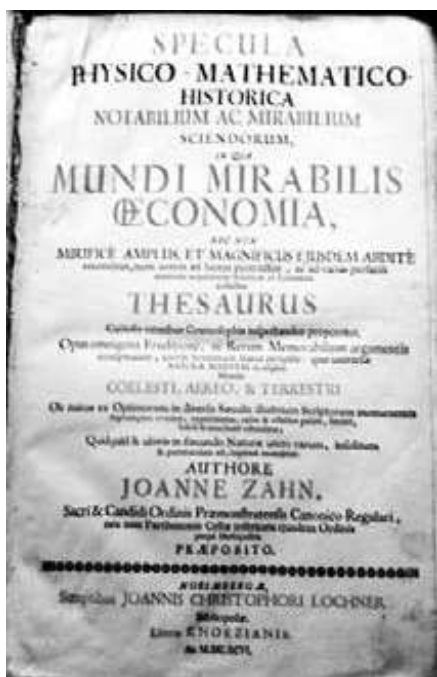

Figure 6-94: The title page of the Zahn's book of the Ljubljana Franciscan Library (Zahn, 1696, 1:).

Zahn's work (1696) on the economically shaped mathematical-physics wonders of the world was bought by Ljubljana Franciscans and Škofja Loka Friars Minor Capuchin, as well as by the Stična monks. Zahn dedicated his first book that contained the first two parts to the Prince Joann Godefrid baron Guttenberg (Gottfried, 1645-1698), the Würzburg Bishop who got his position eleven years after the death of Johan Philipp Schönborn.

Another book with the third part of Zahn's work was dedicated to Otto Philipp Guttenberg (1644 - 1723) the brother and personal adviser to that same already mentioned prince of Bamberg and Würzburg (Herbipolis). Just after the dedication, Zahn printed a giant pedigree of his patron. In the first book he indeed published Geocentric Ptolemy's picture of the world in double A3 format.⁸⁰⁰ He drew orbs around the earth as a cosmos of individual planets. He followed a similar hierarchy of worlds in his further pictures.⁸⁰¹ Finally, he drew on the same picture all three cosmic systems of their major designers: Tycho, Ptolemy and Copernicus.⁸⁰² He then published a map of the lunar surface which looked like Riccioli's-Grimaldi's older lunar map.⁸⁰³ Zahn immediately added a map of the Moon summarized by Jan Hevelius: that Moon looked quite like the earthy surface and somehow anthropomorphic. It was followed by a series of astrolabes with a table needed for providing correct results to their users.⁸⁰⁴ Zahn also published a table of sunspots,⁸⁰⁵ which he then sketched.⁸⁰⁶ He dedicated a special illustration to the changes of the image of Saturn.⁸⁰⁷ Zahn devoted two pages filled by images to both celestial hemispheres pictured with the data of Jan Hevelius.⁸⁰⁸ Zahn already fully compensated the fear of empty of antique philosophers by the weight of air based on Boyle's experiments with a vacuum pump, Borelli's, Mariotte's and Du Hamel's ideas.⁸⁰⁹

At the beginning of the second book Zahn summarized Valvasor's description of the Cerknica lake. For the clarification of the causes of the annual changes of lake water levels, especially the November flood of the Cerknica Lake, Zahn quoted Kircher's *Mundus*, namely the third chapter of the fifth Kircher's book. Zahn also referred to chapters 46 and 47 in the Valvasor's fourth book.⁸¹⁰ Zahn plotted Valvasor's model as Zahn's figure no. 1.⁸¹¹ Zahn imagined the model of the

⁸⁰⁰ Zahn, 1696, 1:2/3.

⁸⁰¹ Zahn, 1696, 1:26/27.

⁸⁰² Zahn, 1696, 1:30/31.

⁸⁰³ Zahn, 1696, 1:40/41.

⁸⁰⁴ Zahn, 1696, 1:56/57.

⁸⁰⁵ Zahn, 1696, 1:62/63.

⁸⁰⁶ Zahn, 1696, 1:84/85.

⁸⁰⁷ Zahn, 1696, 1:98/99.

⁸⁰⁸ Zahn, 1696, 1:122/123.

⁸⁰⁹ Zahn, 1696, 1:308-309.

⁸¹⁰ Zahn, 1696, 2:34.

⁸¹¹ Benedik, 2008, 191, picture attachments at the end of the book. Valvasor's engravings (1689) at page 34 has Zahn's

interior of the earth and the winds completely based on Kircher's ideas. Zahn also provided an illustration.⁸¹² He used Kircher's similar terminology so that Zahn's entitled his third part in the second book *Geocosmi sive Mundi Terrestris*. Zahn described the lake of Cerknica in the fifth chapter immediately after the other wonders of Kircher's and Strabo's collections, directly after Kircher's miraculous plant from Westphalia. After his notes on Valvasor, Zahn published a summary of Pliny's, Strabo's and Cornelius' description of volcanoes around Naples. Zahn then gave a description of the volcano in the Chinese province of Xansi, probably also borrowed from Kircher book *China Illustrata* of 1667. On the next page Zahn described the volcano Etna, and in the next section Zahn embarked on the occult features of the interior of the Earth,⁸¹³ of course again with Kircher's data.

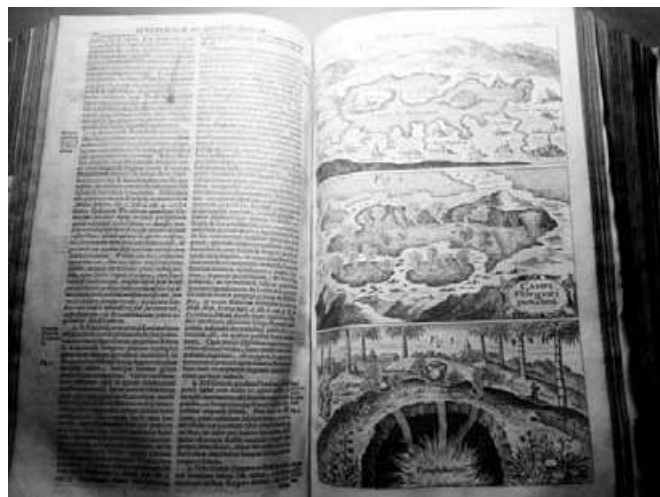

Figure 6-96: Zahn's sketch of Cerknica Lake on top right next to other natural sights (Zahn, 1696, 2:34)

an eye,⁸¹⁵ refraction,⁸¹⁶ Camera Obscura⁸¹⁷ of closed-type like the modern cameras,⁸¹⁸ three guys using sighting technique to determine proportions of a dragon,⁸²⁴ and a refraction of light on the surface of water.⁸¹⁹ Zahn wrote about the physical ratios of the eyepieces,⁸²⁰ the types of optical tubes,⁸²¹ and *Lucerna Magica*.⁸²² He tabulated a combination of concave lenses⁸²³ and the diameters of optical apertures by the researches of the Capuchin Rheita.⁸²⁴ Zahn was interested in the Galileo's or the Dutch telescope,⁸²⁵ the Bologna professor of mathematics Giovanni Antonio Magini's (Maginus, 1555-1617) device for measuring of convexity,⁸²⁶ lens grinding devices,⁸²⁷ microscope control screws.⁸²⁸ Zahn used the apparent average movement of the sun in 1680 for the calculation of the horoscopes.⁸²⁹ Zahn sketched the Sun, Earth and Jupiter⁸³⁰ to be able to calculate the rotation period of Jupiter.⁸³¹ Besides



Figure 6-95: Zahn's chapter on air and vacuum in the Ljubljana Franciscan Library (Zahn, 1696, 1:308).

Zahn dedicated his book to the Bishop Guttenberg of Würzburg and published a whole song in his honor. In his index of matters Zahn did not list many personalities, but he certainly did not forget to note the Jesuit Honorat Fabri.⁸¹⁴ Zahn sketched

book in Škofja Loka Capuchin library and in Ljubljana Franciscan library, but not the NUK copy of Zahn's work..

⁸¹² Zahn, 1696, 2:4.

⁸¹³ Zahn, 1696, 2:37.

⁸¹⁴ Zahn, 1696, 1: 147.

⁸¹⁵ Zahn, 1696, 1: 16.

⁸¹⁶ Zahn, 1696, 1: 23.

⁸¹⁷ Zahn, 1696, 1: 160.

⁸¹⁸ Zahn, 1696, 1: 178.

⁸¹⁹ Zahn, 1696, 1: 226.

⁸²⁰ Zahn, 1696, 1: 209.

⁸²¹ Zahn, 1696, 1: 426.

⁸²² Zahn, 1696, 1: 726.

⁸²³ Zahn, 1696, 1: 284.

⁸²⁴ Zahn, 1696, 1: 293.

⁸²⁵ Zahn, 1696, 1: 390.

⁸²⁶ Zahn, 1696, 1: 439.

⁸²⁷ Zahn, 1696, 1: 478.

⁸²⁸ Zahn, 1696, 1: 531.

⁸²⁹ Zahn, 1696, 1: 786.

⁸³⁰ Zahn, 1696, 1: 665.

⁸³¹ Zahn, 1696, 1: 667.

the regular camera,⁸³² Zahn drew a projection camera,⁸³³ suspension lamp,⁸³⁴ horoscopes,⁸³⁵ parts of the microscope⁸³⁶ and the inclined microscopes with lamp.⁸³⁷ After four pages of appendixes Zahn published the alphabetical index of matter without surnames.

Zahn also published a similar hefty work on artificial optical devices nicknamed "artificial eyes"; the older copy (1685) of Ljubljana Augustinians had the individual chapters paginated separately and different images from the Nurnberg edition (1702), which was purchased by the Jesuits in Ljubljana four years after the printout. Both folio format books were bind into white leather, but Augustinian's book had a slightly softer binding leather.

In 1705, Beno Waldreich (Valterč, * Tyrol; OFMobs Before 1705; 30. 3. 1754 Novo Mesto) got completely New Book of Sebastian Dupasquier (* Around 1630; OFMconv; D. 1718). Dupasquier was a former Provincial of the Province of Saint Bonaventure. Waldreich was a definitor, general lector, provincial, general visitor of Tyrolean and Bavarian provinces. Between the years 1727–1728 he was lector of Philosophy in Novo Mesto. In the years 1731 – 1732 and 1739 he was a lector of theology in Trsat. In 1733 he was a lector of general studies in Ljubljana and magister of the novices. He was a relative of Anton Caharia (Zacharia) Waldtreich, a Ljubljana trader of Tyrol Genus.⁸³⁸

Dupasquier had retired as professor of theology. He denied the vacuum after reading Scotus and Aristotle. In the vacuum there is no resistance to the motions. So, the events in vacuum do not follow one another which makes vacuum impossible. The funny idea could be interpreted in the frames of the modern arrow of entropy which needs causality to provide the necessity of arrow of time moving forwards.

For Dupasquier, the dilution is not insertion of vacuum between the particles of substances, but it

requires mixings of the air and the particles of substances.⁸³⁹ To prove those ideas, Dupasquier mainly used the help of Scotus' works. Dupasquier refused Copernicus and Galileo. Dupasquier debunked them with the acts of the general inquisition from year 1666,⁸⁴⁰ rather than with the arguments of reason or experience. Dupasquier likewise insisted on the antic four elements and refused the additional items of chemists and one sole substantial particle of atomists.⁸⁴¹



Figure 6-97: Title page of Dupasquier's third book with Ex Libris of Beno Waldreich in Ljubljana Franciscan library (Dupasquier, 1705, 3. part); F.

Škerpin acquired the academic natural history science of Trnava professor Laurentius Tapolcsányi and his student Ladislav Korlatkőy. Tapolcsányi was a rector in Trnava between the years 1719 – 1721 and again just before his death. Tapolcsányi did not follow the sequences of narration of Aristotelian physics and other peripatetic books in three separately paginated parts of his book. Tapolcsányi's vacuum was not specifically highlighted in a separate paragraph. Tapolcsányi added fifty exam questions on the end of his book. Tapolcsányi's Vacuum was identified as supernatural, but movement in vacuum

⁸³² Zahn, 1696, 1: 728.

⁸³³ Zahn, 1696, 1: 732.

⁸³⁴ Zahn, 1696, 1: 735.

⁸³⁵ Zahn, 1696, 1: 77.

⁸³⁶ Zahn, 1696, 1: 789.

⁸³⁷ Zahn, 1696, 1: 793.

⁸³⁸ Valenčič, Vlado. Waldtreich zu Ehrenporten, Caharija (1623–1682), *SBL*. 4/14: 661.

⁸³⁹ Dupasquier, 1705, 3:475, 484; 4:152, 156, 159.

⁸⁴⁰ Dupasquier, 1705, 4:50 – 51.

⁸⁴¹ Dupasquier, 1705, 4:85.

nevertheless required considerable time and was not instantaneous and therefore impossible.⁸⁴²



Figure 6-98: Title page of Korlatkőy's physics exam in Trnava professor Tapolcsányi's class with Škerpin's manuscript Ex Libris on the top (Tapolcsányi, 1706); F.

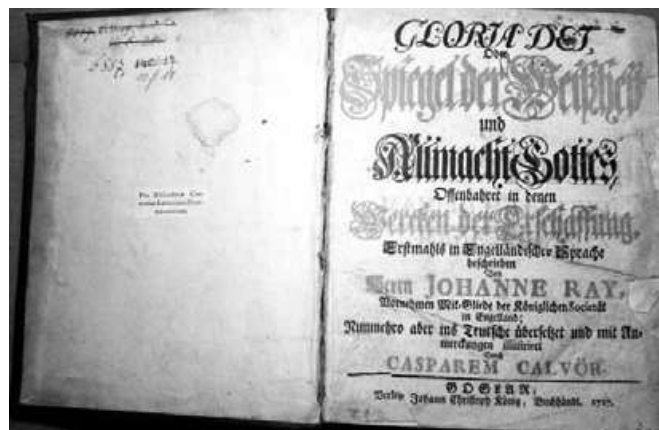

Figure 6-99: The title page of Ray's book in Ljubljana Franciscans' library (Ray, 1717).

In Ljubljana, Franciscans soon began to purchase books in German language, including a book of member of the Royal Society John Ray FRS (b. 1627; d. 1705) in the translation of Lutheran theologian Caspar Calvör (Calvoer, * 1650

⁸⁴² Tapolcsányi, Korlatkőy, 1706, unpaginated examination thesis no 22 on the end of book.

Hildesheim; d. 1725 Clausthal) published in the year 1717. The translator added dozens of pages of details on vacuum pumps in footnotes below the line in the chapter about air.⁸⁴³



Figure 6-100: Pourchot's table of pictures presenting the distillation (Pourchot, 1730, 2: Table 6)

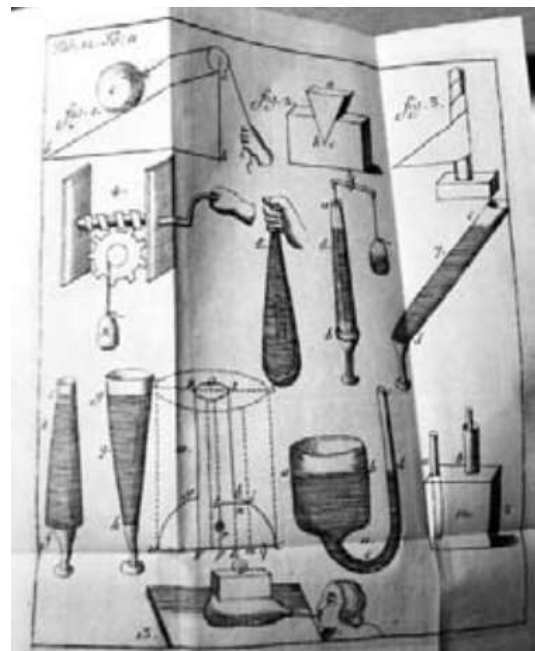

Figure 6-101: Pourchot's plate with images of vacuum cohesion, blowing needed to prove the pressure of air, and communicating vessels (Pourchot, 1730, 2: Table 11)

⁸⁴³ Ray, 1717, 317.

The Capuchins of Škofja Loka, the Friars minor observants of Ljubljana and Rijeka friars purchased late edition of Pourchot's textbook. The Jesuits were certainly not his fans. For a quarter of century Edmund Pourchot (Edme Purchotius) was a Parisian domestic tutor of the nephew of leading Jansenist Pascal's friend Antoine Arnauld (1612 Paris-1694 Brussels) before Pourchot became the professor of philosophy at university of Paris and later got the honor of a rector seven times. He began to publish his lectures entitled *Institutio philosophica ad faciliorem veterum ac recentiorum philosophorum lectionem comparata* in four volumes in Paris in 1695. His first volume was initially devoted to logic, metaphysics and elements of geometry; the second to the general principles of physics (optics, mechanics); the third to cosmology and the natural sciences; the fourth to ethics and *Exercitationes scholasticæ*. The author then perfected this work until the end of his life, and there were several other editions during his lifetime and later with the title changed in the plural as *Institutiones philosophicæ*. In 1739 edition purchased in Carniola Edme Pourchot wrote about vacuum in the second volume of his work inside his General physics, which he finished with the seemingly occult phenomena among which he added sympathy, antipathy and Antiperistasis (ἀντί περίστασις).⁸⁴⁴ But right there the leaves in the copy of the book in the library of Franciscans of Ljubljana are not cut, and so the book did not exactly inflame the fans among the Ljubljana Franciscans.⁸⁴⁵ He crowned his description of motion in the vacuum⁸⁴⁶ with an indication of experiments of Johan Christoph Sturm and the theologian Henry More (Heinrich Morus, 1614-1687) from Cambridge, with good illustrations and detailed descriptions of pumps.⁸⁴⁷ All phenomena of fear of empty were attributed to the air pressure and Pourchot described Pascal's experiments. Next, Pourchot followed his ideas by a chapter dedicated to light, color and sunshine,⁸⁴⁸ but Pourchot's electricity and magnetism did not get any specific chapter and neither did Pourchot provide any images about them. In his penultimate third book on special physics Pourchot narrated about astronomy with a fairly details focused on his presentation of Tycho's system, sketches with

Cartesian vortexes in space⁸⁴⁹ and biology. The Cartesian vortexes apparently show Pourchot's sympathies for Descartes, much like later Bošković's curve of forces have only been published by Bošković's advocates. Despite Descartes' denial of vacuum and Cartesian theological disputes with Arnauld, Pourchot was one of the most important proponents of Descartes' physics combined with the Parisian academic scholastics. Pourchot's books took the new philosophical spirits to Poland, as well as into Turkey or in Ljubljana.

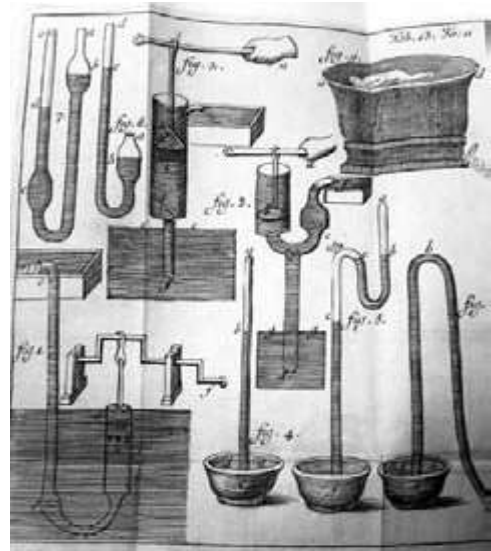

Figure 6-102: Pourchot's table of images with barometers (Pourchot, 1730, 2: Table 13)

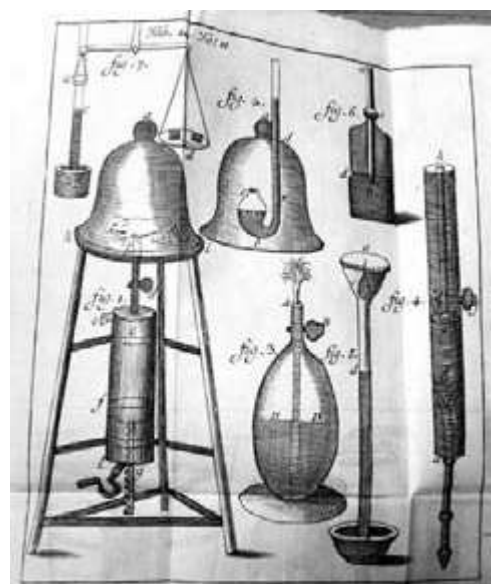

Figure 6-103: Pourchot's table of images with vacuum pumps (Pourchot, 1730, 2: Table 14)

⁸⁴⁴ Pourchot, 1730, 440.

⁸⁴⁵ Pourchot, 1730, 405-406.

⁸⁴⁶ Pourchot, 1730, 312-331.

⁸⁴⁷ Pourchot, 1730, 300, table of figures 14.

⁸⁴⁸ Pourchot, 1730, 314, 316, 341-363.

⁸⁴⁹ Pourchot, 1730, table of figures 20.

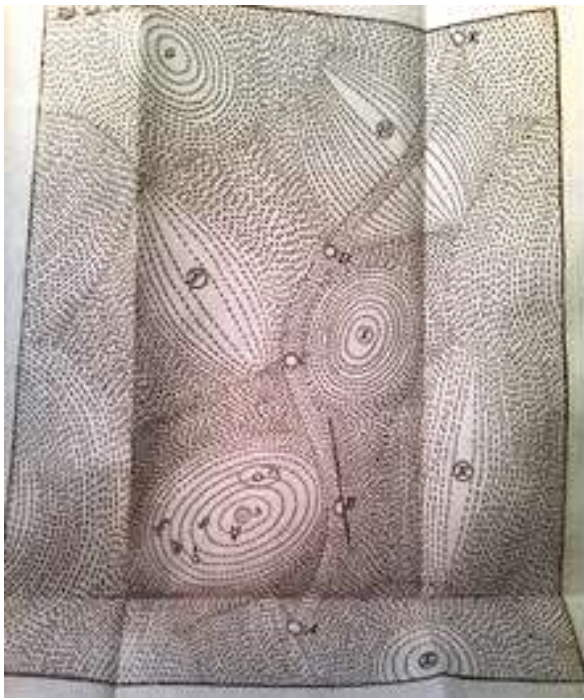

Figure 6-104: Pourchot's presentation of Descartes' vortices in space at Ljubljana Franciscans' library (Pourchot, 1730, 3: Table 19)

The enthusiasm of the Ljubljana Franciscans about the Cartesian charms of the divine Paris has only escalated, therefore they also purchased the books of Regnault and of Pourchot's fellow at the Parisian University a member of the Parisian Academy Laurentius Duhan (* 1656 Chartres † 1726 Verdun), who lectured in philosophy in Sorbonne Collège de Plessis for over three decades. Of course, the general lector, definitor, several times guardian (custos) Avrelij Čeuko († 16. 5. 1746 Ljubljana) as a Ljubljana Franciscan lecturer in philosophy, purchased the latest issue of Duhan's philosophy in 1727. Duhan studied in Montaigu in the Vendée department in the Pays de la Loire region in western France, where they always hired two professors of philosophy. Among Duhan's students at Sorbonne-collège du Plessis was later distinguished Jean Denyse, the professor of philosophy at the prestigious collège de Montaigu at the University of Paris. The older edition of Duhan's philosophy arrived in Ljubljana Lyceum Library from Stična. It was printed in 1708 but left without bookplates and bind in brown leather, different from mostly white covers of Stična books. In a later edition (1715) it was read by Maribor Friars Minor Capuchins.

In his very popular book Duhan explained the vacuum in sophistic way popular before the

Socrates's age by pointing the arguments for and against. In his introduction Duhan set forty-eight queries enumerated with Roman numbers. He put the puzzles about physics next to them with some interesting titles like:⁸⁵⁰ *De Definitione Physices*,⁸⁵¹ *De Divisione corporis*⁸⁵² and *De Definitione Anima*.⁸⁵³ Duhan proclaimed physics as the speculative science of natural bodies, which dealt with the causes of mixtures of bodies and elements. He followed Aristotle regarding the matter and shape as the basic characteristics of the body. Duhan defined nature as the principle and cause of the movement.⁸⁵⁴ The natural bodies are divided into a simple and assembled.⁸⁵⁵ After his logic, moral philosophy and metaphysics, the physics was the fourth and last part of the book⁸⁵⁶ entitled *De Rebus Physicis*.⁸⁵⁷ With his chosen examples, Duhan proved that physics is not perfectly absolutely true,⁸⁵⁸ which was the agnostic position of the English antiquarian Thomas Baker's (1656-1740) *Reflections on Learning, showing the Insufficiency thereof in its several particulars, to evince the usefulness and necessity of Revelation*. The item was printed in London by A. Bosvile in 1699, and again in London in 1709-1710. It became very popular in Ljubljana and Zagreb Jesuit headquarters in the following decades culminating with the Cartesian Kazimir Bedeković Komorski and Josephus Mathias Engstler's *Tractatus de incertitudine scientiarum, recens ex italico latine redditus, Zagrabiæ: Cajetani Francisci Härtl, Anno 1759, Dum Assertiones ex universa Philosophia... Collegii Labaci*. A member of the Parisian Academy Laurentius Duhan was certainly aware of the French translations of Baker's treatise of Nicolas Berger which were published in Paris in 1714, in Lyon in 1721 and in Amsterdam in 1715.

Despite the unambiguous following of Aristotle, Duhan also tackled a completely modern special physics. He especially highlighted the vacuum as an absolute real item, but without Duhan's indication of individual experiments.⁸⁵⁹ Soon

⁸⁵⁰ Duhan, 1708, XXII-XXXII.

⁸⁵¹ Duhan, 1708, XXII.

⁸⁵² Duhan, 1708, XXIX.

⁸⁵³ Duhan, 1708, XXX.

⁸⁵⁴ Duhan, 1708, XXVII.

⁸⁵⁵ Duhan, 1708, XXIX.

⁸⁵⁶ Duhan, 1708, 319-464.

⁸⁵⁷ Duhan, 1708, 319.

⁸⁵⁸ Duhan, 1708, 321.

⁸⁵⁹ Duhan, 1708, 380; Duhan, 1726, 323-331.

afterwards the Jesuit Baron Anton Erberg of Dol manor promoted Jean Vincent's book against Cartesian interpretation of the vacuum in Vienna in 1730.⁸⁶⁰

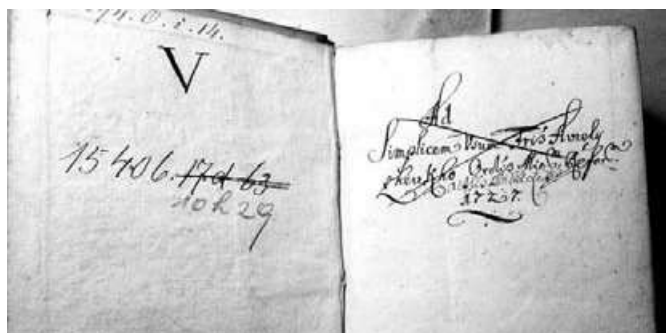

Figure 6-105: The crossed out proprietary entry of Aurelius Čeuko († 16. 5. 1746 Ljubljana) on the title page of Duhan's philosophy of Ljubljana Franciscans' library (FSLJ-17 D 63).

Duhan followed the Cartesian laws of movement⁸⁶¹ and various systems of the cosmos:⁸⁶² Ptolemy, Copernicus and Tycho. Copernicus can be defended (only) as a hypothesis, Duhan claimed, but Duhan did not deal specifically with Tycho and was not holding Copernican positions anyway.⁸⁶³ Copernicans were still banished in Papal index. Duhan rejected the Ptolemy's system,⁸⁶⁴ while Duhan only allowed Copernican ideas as the hypothesis.⁸⁶⁵ The only remained was Tycho, whom in contrast with the rest, Duhan didn't even try to refuse.

Duhan listed the causes of tide,⁸⁶⁶ described the nature of the light,⁸⁶⁷ especially focusing the refraction,⁸⁶⁸ and the nature of heat.⁸⁶⁹

Duhan discussed the endless divisibility of the particles in a later Bošković's sense,⁸⁷⁰ but, unfortunately, Duhan did not illustrate his ideas with sketches like the subsequent Bošković's fans. Duhan's vacuum was possible in absolute terms,⁸⁷¹

as allowed by God.⁸⁷² Unfortunately, Duhan mainly philosophized and did not mention Torricelli's and other experiments with barometers.⁸⁷³ The description of heterogeneous bodies has finished Duhan's discussion on Vacuum.⁸⁷⁴ He was interested in simple experimental lifting of heavy bodies,⁸⁷⁵ which was to some extent the opposite of Aristotelians, with many traces of Galilean way of experimenting. Duhan first assumed that the vacuum was absolute possible.⁸⁷⁶ He then set a series of assumptions that could be refused with the arguments like: the weight of the air is the real cause of movement. The presumption was quickly challenged by the great avalanche of doubts questioning even the description of the operation of the vacuum pump and mercury in the barometer.⁸⁷⁷



Figure 6-106: The title page of Duhan's philosophy in Ljubljana Franciscans' library (Duhan, 1726).

Duhan participated in the debates on the Newtonian oblate (oblatum) versus Cassini's oblong (oblongum) earth focused on the terrestrial emission of magnetic flows (Efluvium) unaffected by gravity.⁸⁷⁸ By Peraldi (Guilelmus Peraldu) and

⁸⁶⁰ Erberg, 1730, 56-61.

⁸⁶¹ Duhan, 1708, 415; Duhan, 1726, 352.

⁸⁶² Duhan, 1708, 419.

⁸⁶³ Duhan, 1708, 422.

⁸⁶⁴ Duhan, 1708, 419.

⁸⁶⁵ Duhan, 1708, 422-423.

⁸⁶⁶ Duhan, 1708, 429.

⁸⁶⁷ Duhan, 1708, 436.

⁸⁶⁸ Duhan, 1708, 444.

⁸⁶⁹ Duhan, 1708, 447.

⁸⁷⁰ Duhan, 1708, 374.

⁸⁷¹ Duhan, 1708, 380.

⁸⁷² Duhan, 1708, 381.

⁸⁷³ Duhan, 1708, 384.

⁸⁷⁴ Duhan, 1708, 389.

⁸⁷⁵ Duhan, 1708, 393.

⁸⁷⁶ Duhan, 1726, 323.

⁸⁷⁷ Duhan, 1726, 333-334, 343, 344.

⁸⁷⁸ Duhan, 1708, 407.

the relevant experiments which checked the behaviour of vacuum. He was interested in the potentially possible supposed air above the atmosphere of Earth and tried to solve the main problem of the vacuum technique of his times, namely the possibilities for the flight of the angels through empty space. He described the experiments with mercury, probably the one from Idrija Mine in Carniola, and became very interested in Boyle's air pump with its recipients and glass vessels. Frassen researched the condensation and thinning of substances. Frassen tried to press the air and most of all he liked to conserve the fruits, flowers, meat, and similar devices in vacuum which he considered to have almost divine properties.⁸⁹⁹ In that way, the vacuum transformed from the persona non grata of horror vacui into the divine glorified subject. There were many of his contemporaries who shared his opinion believing that Aristotle reasonably proved the impossibility of vacuum, but the omnipotent God had the abilities to create it anyway.

The new bettered edition of Frassen's masterpiece was provided by José Maria Ribeiro Fonseca who arrived in Rome as a youngster to become a Franciscan in Rome on 8 December 1712, few months after Frassen passed away.



Figure 6-112: Copernican system in Frassen's philosophy at Ljubljana Franciscans' library (Frassen, 1686, 466).



Figure 6-111: The title page of Frassen's philosophy at Ljubljana Franciscans' library (Frassen, 1686).

⁸⁹⁹ Claudio Frassen, José Maria Ribeiro da Fonseca, *Philosophiae academicae*, Tolosae: Guillelmo Ludovico Colomer, 1686; Reprint: *Philosophiae academicae, I logicam et metaphysicam completens 2 primam et secundam partes physicae impertarium completens 3 tertiam partem physicam completens 4 moralem scientiam completens... recens in lucem edita correctior & enendatior... Josephi Mariae ab Eborae...* Romae: Rocchi Bernabe (FSLJ-13 c 28), 1726, 2: pp. 274, 327, 328, 334, 335, 336, 342, 343, 344.

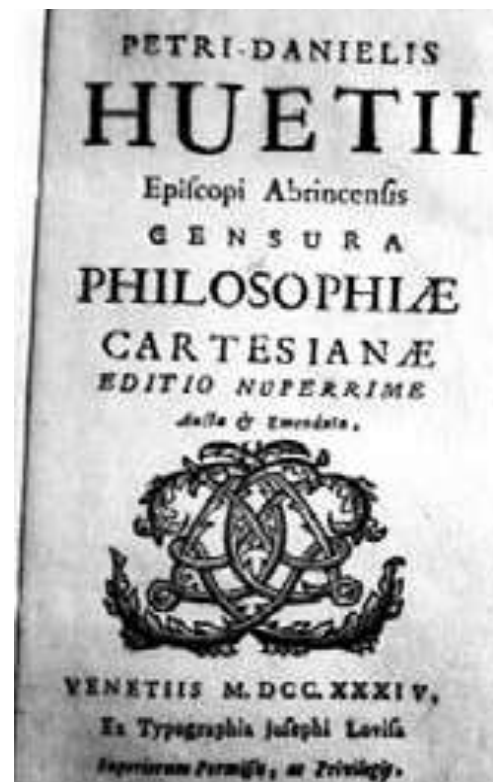

Figure 6-113: The title page of the Huetius' book.

Ludwig von Gallenfels (Golnik, baptized Johann Jakob on 14. 12. 1662; OFMobs; d. 22. 2. 1728 Kamnik) used his forty years older edition of Frassen's book issued when he was a graduate student. Ludwig von Gallenfels was a son of the owner of manor Golnik and the governor of Bled

Johan Andreas Gallenfels and his wife Anna Maria Kuschlan from Zablate manor by Brezovica by Ljubljana. Ludwig's godfather was Andreas baron Trilleck, the grandfather of Jurij Andrej Triller Count Trilek (1663-1701) who owned Lana's book of vacuum balloons published in 1670 while Škerpin got half of a century later edition of Lana's work. Ludwig Gallenfels certainly knew Lana's ideas which influenced Ludwig Gallenfels's opinions about the reality of vacuum. Ludwig Gallenfels became the Ljubljana Franciscan lector and then provincial of Bosnian Croatian province in 1702-1704. As a lector, Ludwig Gallenfels used the book of Frassen to learn about the differences between a common and philosophical vacuum.

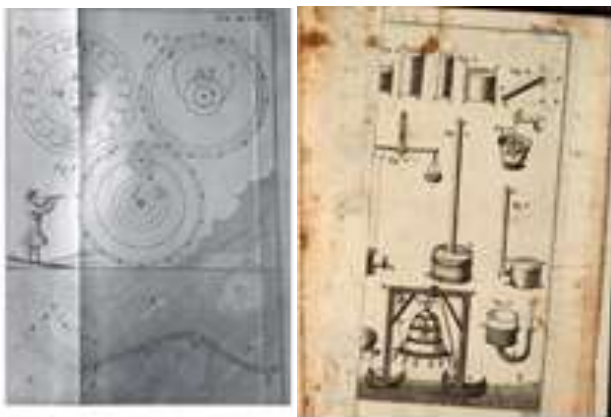

Figure 6-114: Images of solar system and measurement of weight of air from the second part of the Ferrari's philosophy with physics (Ferrari da Monza, 1754, 2: Tab 1).

After Gallenfels passed away, the Ljubljana Franciscan rector Scotus's follower Hieronim Markilič (1712–1790) commented on Frassen's description of the vacuum experiments in the older previous Gallenfels' edition of 1686, which means that Škerpin acquired a newer edition of 1726 after Markilič wrote his manuscript notes. In terms of vacuum testing, Markilič recommended "Our Pater Frassen".⁹⁰⁰ The book of French Franciscan Frassen was the one used as a textbook by both Gallenfels and his half a century younger colleague anti-cartesian Markilič. Markilič described his vacuum in his comments on fourth Aristotle's book⁹⁰¹ by describing Gassendi's atoms of various

⁹⁰⁰ Frassen, 1686 *Physica de Vacuo*, folio, p. 385 and onwards; Frassen, 1726, 2:339 and onwards; Markilič, 1755? Incipit Philosophia, 785.

⁹⁰¹ Markilič, 1755? Incipit Philosophia, 774-785.

forms and Descartes' opposition to the vacuum.⁹⁰² The fashionable production of a vacuum in the pipe (Fistula) put the lie to fear of vacuum,⁹⁰³ even if vacuum still provided the obstacles for the movement of Angels and Lucifer himself in a vacuum⁹⁰⁴ for the sake of a slight resistance of any movement in the vacuum⁹⁰⁵ until the rocket propulsion saved those problems of travelling angels. In his comments on Aristotle's formation and decay, Markilič briefly summarized the dilution of the substance and specifically described the air as one of the basic subjects of meteorological phenomena.⁹⁰⁶

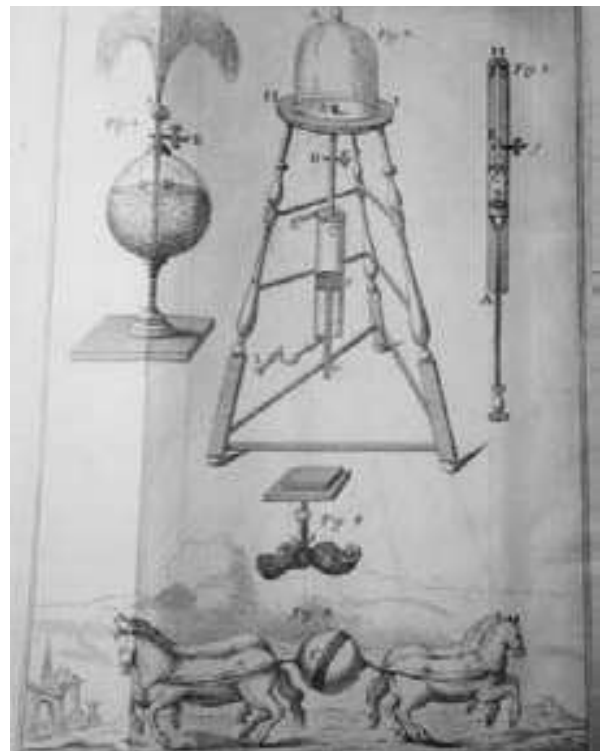

Figure 6-115: Images of vacuum pumps and experiment with Magdeburg hemispheres in Regensburg from the second part of the Ferrari's philosophy with physics (Ferrari da Monza, 1754, 2: Tab 2).

Peter Daniel Huetius (Pierre Huet, b. 1630 Caen; d. 1721) the Bishop of Abrincensis (Avranches) in Normandy used to be among the most talented Frenchmen of his generation. His criticism of Cartesians was republished posthumously in Venice with a quote of the Descartes' jar full of wine, which was still not completely empty even

⁹⁰² Markilič, 1755? Incipit Philosophia, 775.

⁹⁰³ Markilič, 1755? Incipit Philosophia, 776.

⁹⁰⁴ Markilič, 1755? Incipit Philosophia, 778.

⁹⁰⁵ Markilič, 1755? Incipit Philosophia, 781.

⁹⁰⁶ Markilič, 1755? Generatione et Corruptione, 16-17, 130-131.

after a noble gulped down the precious liquid down his throat.⁹⁰⁷ Similarly, the Köln Jesuit University professor of philosophy the Cartesian Mathia Heimbach (* 1666; SJ; D. 1747) imagined thirteen years later, when he swore on the unnatural vacuum, Cartesians and residue of the subtle substance in the barometer.⁹⁰⁸ The Franciscans of Ljubljana used both books, but they probably soon preferred Anti-Cartesian and anti-Jesuitical stances.



Figure 6-116: Figure 2 explained Hauksbee's measurement of the weight of air at the second part of Ferrari's philosophy with physics (Ferrari's da Monza, 1754, 2: Tab 3 and p. 2:81).

Škerpin also bought his contemporaries' physics, among them the modernized peripatetic discussion of the Franciscan Scotus' fan Josef Anton Ferrari from Monza (Giuseppe de Modoetia, D. 1776). Ferrari pictured many barometers and drew strong youngsters trying to weight the vacuum. He was also interested in the newly invented steam engines which slowly penetrated from industrially more advanced England into European coastlands. He did not forget to show the famous Magdeburg vacuum experiment with horses which was performed in Regensburg. The inventor Otto Guericke gave considerable credit to the Ljubljana prince Janez Vajkard Auersperg who attended the Regensburg diet as the informal prime minister of the Habsburg Emperor. Ferrari asked himself about the vacuum and answered in the manner of Gassendi, Boyle, and the famous Newton. Ferrari

⁹⁰⁷ Huetius, 1734, 149.

⁹⁰⁸ Heimbach, 1747, 2:399, 400, 403.

had his hardest time to figure out if the vacuum could conserve and preserve itself. He resolved that fundamental question with Torricelli's atomism although he also cited the Cartesian critiques of existences of void spaces. The main supporter of the atomic theory was certainly a Roman Lucretius, and Ferrari relied on him by experimenting with Magdeburg vacuum hemispheres.⁹⁰⁹ Ferrari became an established researcher of barometers. Joseph Anton Ferrari's group of pictures VII at the end of the book has barometers in the first picture, as well as on the second and third figures of the fourth group. In the second figure of group III he drew nice strong youngsters, who "weigh" the vacuum and then embarked on steam engines. In group II he had a picture 3 with vacuum pumps and a Magdeburg experiment with horses in Figure 5 borrowed from Du Hamel's book, which was also purchased by the Ljubljana Jesuits.



Figure 6-117: Figure 1 with barometers, Figure 2 with Pascal's experiment and figure 4 showing the lifting of water by vacuum pump from the second part of the Ferrari's philosophy with physics (Ferrari da Monza, 1754, 2: Tab 4 and pp. 2: 83, 84).

⁹⁰⁹ Giuseppe Antonio Ferrari da Monza, 1746, 1747, Venetiis: M. Fentium. Reprint: *Philosophia peripatetica... Johannis Duns Scoti... philosophia, logica, metaphysica, ethica* Venetiis: Thoma Bettinelli (FSLJ- 2 i 10-12), 1754, 2: pp. 77, 81, 332, 334, 335-336, 338-343.



Figure 6-118: Huygens' siphons in Figure 4 from the second part of the Ferrari's philosophy with physics (Ferrari da Monza, 1754, 2: Tab 5 and p. 2: 88).



Figure 6-120: The title page of the second part of the philosophy, with a description of the vacuum of Petrus a S. Catharina and Thoma a S. Joseph of 1714, which was purchased by Škerpin for Ljubljana Franciscans.



Figure 6-119: Figure 1 showing the Pisan professor Carlo Taglini's (1679-1747) and E. Halley's research on the balance of air and water from the second part of the Ferrari's philosophy with physics (Ferrari da Monza, 1754, tab 6 and pp. 2:91, 94).



Figure 6-121: One of the biggest books on the vacuum of all time rests at the Ljubljana Franciscans' library. Its lifting is recommended only after a plentiful meal (Locherer, 1740, 2: 472 (with the permission of the father Dr. Miran Špelič OMF)).



Figure 6-122: The Title page of the Locherer's paragraph about vacuum of Ljubljana Franciscans' library (Locherer, 1740, 2: 438).



Figure 6-123: Copernicus system of Locherer in Ljubljana Franciscans' library (Locherer, 1740, 4:56 (with the permission of Dr. Miran Špelič OMF)).

Of course, the Ljubljana Franciscans mainly trusted their religious co-brothers on the philosophical issues of the vacuum. That's why Škerpin bought the Venetian peripatetic physics of Spanish Franciscans Petrus a S. Catharina (Pedro de Santa Catalina, OFM) and Thomas a S. Joseph (Fr. Thoma a Sancto Ioseph) from Franciscan Observant Provinces of St. Joseph of barefoot (Disalceatorum, Ordo Fratrum Minorum Disalceatorum o Alcantarinorum / O.F.M. Disc. /

O.F.M. Alc.) and Peripatetic philosophy of Italian Antonio Ferrari from Monza. The Ljubljana Franciscans had two copies of Petrus a S. Catharina's course, since they had already purchased the same issue printed in 1697 before Škerpin brought in the newer version. Petrus a S. Catharina described his vacuum on dozens pages of a small format.⁹¹⁰ Despite of dubious experiment with a vacuum, God can create and even allow angels to fly through it, and Petrus a S. Catharina has attributed the similar courage to the animals. The local movement in the vacuum is a miracle because the vacuum has no location as claimed already by Benedictus Valentin Pererius.⁹¹¹

Škerpin also bought a powerful Scotus' philosophy with the physics of his religious co-brother Alipius Locherer (OFMobs), the general lecturer and definitor of the Austrian province. Locherer still relied on the old scholastic grips. However, Locherer's Aristotelian eight physics books shrunk into seven, where the vacuum was dealt at the end of sixth book. He went so far as to refuse Descartes and with him Locherer declined whole Copernican system with Galileo and Kepler included. Locherer quoted the Italian poet Alessandro Tassoni. Even Tycho Brahe and William Gilbert were not sufficiently good for Locherer as he preferred to cite Antoine Goudin and Guérinois.⁹¹² Ljubljana Franciscans also liked to read Guérinois' books. Locherer relied on (Compton) Carleton's work, which was also read by Ljubljana Franciscans; Compton Carleton devoted his book to Bavarian electoral prince Maximilian II Emanuel (b. 1662; d. 1726) just like Locherer a half-century after him dedicated his work to Maximilian's morganatic son Emanuel Francois Joseph count of Bavière marquise Villacerf. The pleased Emanuel repaid Locherer's dedication with some golden coins.⁹¹³ Cardano and Girolamo Fracastorio (Hieronymus Fracastorius, b. 1478 Verona; d. 1553 Calfi (Alfi) by Verona) have demonstrated the supposed natural fear of the vacuum, which the Cartesians wrongly supported but God can still create a vacuum just as God can destroy all between heaven and earth of naughty disobedient

⁹¹⁰ Petrus a S. Catharina, Thoma a S. Joseph, 1697, 2:488-498.

⁹¹¹ Petrus a S. Catharina, Thoma a S. Joseph, 1697, 2:492, 494, 495.

⁹¹² Locherer, 1740, 4:56 left column, 57 both columns, 60 left column.

⁹¹³ Locherer, 1740, 2:471 right column.

infidels.⁹¹⁴ Locherer attributed the Torricellian experiment of 1643 to the peripatetic Jesuit George de Rhodes (1597-1661) and to the researches of Valeriano Magni in conjunction with Bernard Sannig (OFM) whose books were also read by Ljubljana Franciscans, but Magni's visual evidence of vacuum did not fully convince Locherer who preferred to believe Cornaeus and Gassendi.⁹¹⁵



Figure 6-124: Supplementary cover image of Sannig's book (Sannig, 1684, 1) and Sannig's sketch of Tycho's and Ptolemy's system in the Ljubljana Franciscans' library (Sannig, 1684, 2: 259); F

The Bohemian Bernard Sannig (b. 1637; OFM; D. 1704 Znojmo) was a minister of the province of Bohemia, Silesia and Moravia in Prague during many years. In 1676 as the Visitor of Province of St. Ladislav he also visited the monasteries of Ormož, Trsat and Zagreb. He was a

professor of sacred canons at the emperor Karl's convent of Sanctæ Mariæ ad Nives (Our Lady of the Snows, Panny Marie Sněžné) near Jungmann Square in Prague, Minister of the Bohemian province and former Cismontane general commissioner in Prague. He dedicated his immense textbook of Scotus' philosophy to the main members of the reigning Habsburg imperial family with Leopold I included at the first place to receive as much of their pleasant support as possible. In the beginning, he listed a few dozen pages of Franciscan theological and philosophical writers alphabetically arranged by their names and even surnames. Unfortunately, he has probably considered only his own reformed branch of the Friars minors with Roger Bacon and Ockham, while he neglected the Minim Mersenne or the Capuchin Valeriano Magni or Anton Maria Schyrl Rheita. We miss of course also the Strict Observant Fortunio Brixianus, who was born after the printout of the Sannig's book. The second physical part of the book with independent pagination was dedicated to the prince-bishop of Bratislava Frančišek Louis, while the third part with meteorology, geography and metaphysics was dedicated to his general secretary, Peter Marino Sormann from Milan. The physical part was divided into four tractates. In next to last tractate in the 15th *Distinctio* he described the puzzles of vacuum. Unfortunately, he considered for vacuumists rather unfavorable habit of these days and he devoted his rich illustrations only to the winds in meteorology, and above all he decorated his chapters which explained astronomy and the sundials. There he set with his whole heart on the lost Ptolemy's side, even if the table of heights of the sun for the needs of gnomons were summed up by the main Tycho's supporter the Jesuit Clavius.⁹¹⁶ So much more he wrote about the vacuums. He introduced four vacuum observations: the attraction of smooth pressed surfaces, the barometer in water, the movement of the planets and the flame of the candles in a closed tube. He rejected them one by another. He then embarked on vacuum experiments of the Capuchin Valerio Magni with a brief mention of Torricellian achievements and rejected them too. As usual, he then introduced his *Deus Ex Machina*, the creator itself, who is naturally almighty and easily creates an otherwise impossible vacuum. Scotus' rejection of movement in the vacuum was supported by Mastrius (Barthol Mastrio de Meldula OFMconv),

⁹¹⁴ Locherer, 1740, 2:473 right column.

⁹¹⁵ Locherer, 1740, 2:476 right column-477 both columns.

⁹¹⁶ Sannig, 1685, 2:259, 3:242, 300 (notes as *Clavij*).

Poncius (Joannes Poncius OFM), Ruvi(us) and D. Thomas, perhaps Petrus Thomas OFM, whom Sannig noted elsewhere. Sannig opposed Albertus (Magni), Raffaello Aversa (b. 1598; d. 1657), Gregorio Bencio Ariminensi (Gregor Arimin Nenzi), Burlaeus (Walter Burley) or Charles Egide (Gilles) Duhan de Jandun (b. 1685 Jandun in Campagne; d. 1746 Berlin). Scotus' successive continuous movement in the vacuum was supported among others by Columbus (Bonaventura Columbo OFM), Mastrius (Maistris) and Belluto (Bonaventura Belluto Catanensi OFM) against the ideas of Averro(es) and his editor Agostino Nifo (Svessan, Suessan (* ca. 1469/1473 Sessa Aurunca in Italy; d. 1538 Aurunca).⁹¹⁷ Of course, all Scotus' supporters were *Nostrum (Ours)*, therefore the Franciscans, while their opponents were outside their order. In the chapter about the air he did not add comments on the vacuum except the ancient findings of the rarefied air on the Olympus,⁹¹⁸ which was much scarcer than two decades older numerous examples of Sannig's religious co-brother Sichen.

In 1756 the Benedictine Gallo Cartier (Gallus) published his overview through all the fields of philosophy in a gigantic book, which was bought by the curator of Ljubljana Franciscans, the provincial elected twice, visitor of Bohemian and Slavonian province Vincent Marjašič (OFM; d. 13. 1. 1770 Kamnik). Cartier mostly tested Gassendi's ideas in the light of the vacuum and noted that the vacuum was possible, in contrast to the Cartesians.⁹¹⁹

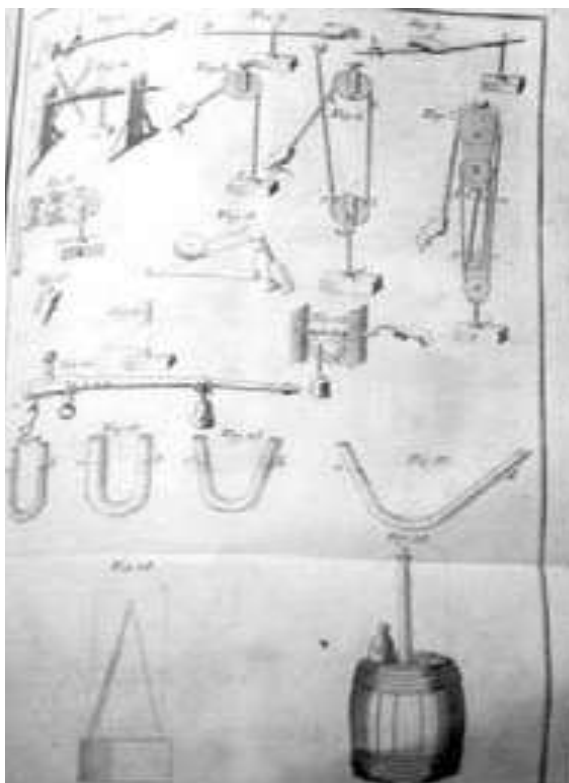

Figure 6-125: The first table of images with mechanics and hydrostatics in Cartier's work at Ljubljana Franciscans' library (Cartier, 1756, table 1).

⁹¹⁷ Sannig, 1685, 2: 224 both column, 225 right, 226 both columns.

⁹¹⁸ Sannig, 1685, 2:322 right column.



Figure 6-126: Table of images of Copernican system in Cartier's work at Ljubljana Franciscans' library (Cartier, 1756, table 2).

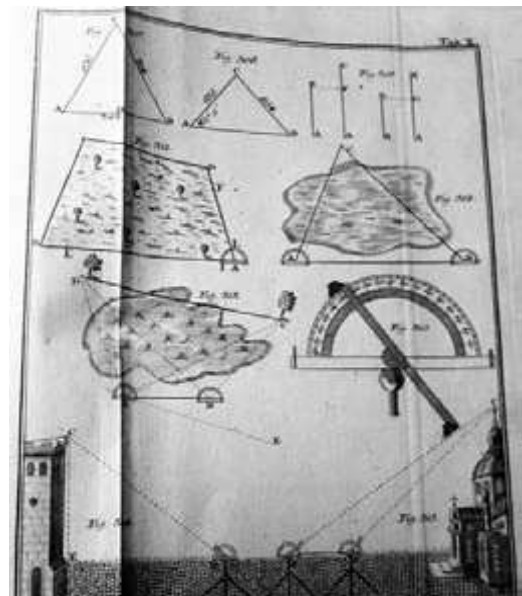

Figure 6-127: Table of optical measurements in Cartier's work at Ljubljana Franciscans' library (Cartier, 1756, table 12).

⁹¹⁹ Cartier, 1756, 481.

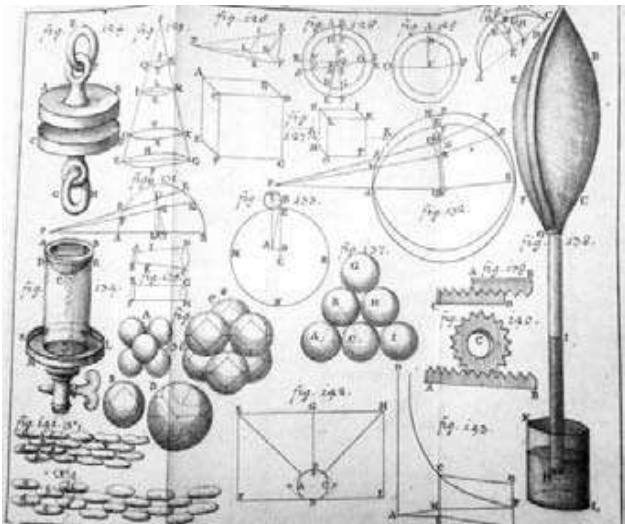

Figure 6-128: Scherffer's vacuum experiments at the library of Ljubljana Franciscans (Scherffer, 1752, figure 134).

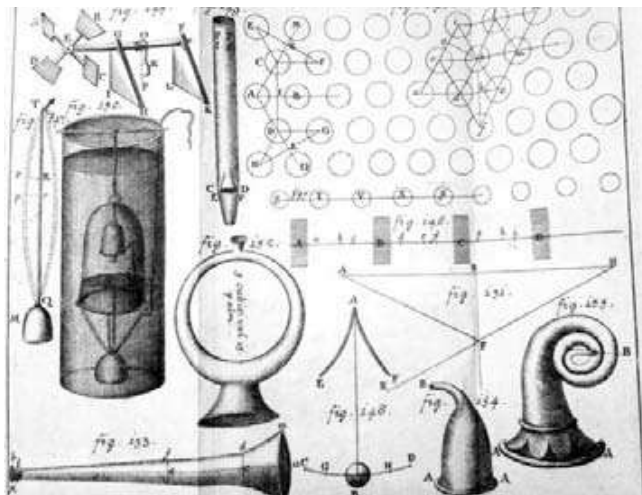

Figure 6-129: Scherffer's vacuum experiments at the library of Ljubljana Franciscans (Scherffer, 1752, figure 150).

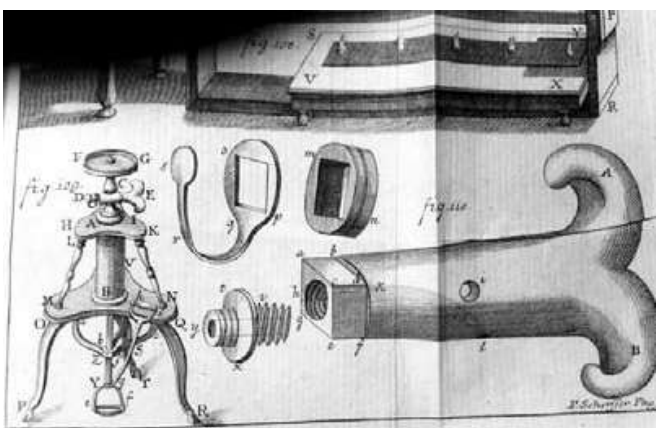

Figure 6-130: Scherffer's vacuum experiments at the library of Ljubljana Franciscans (Scherffer, 1752, figure 109).



Figure 6-131: Picture facing Nollet's titlepage in the library of Ljubljana Franciscan Monastery (Nollet, 1751)

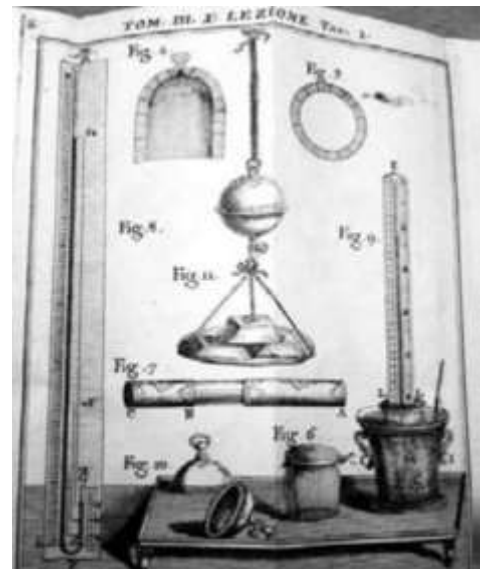

Figure 6-132 : Nollet's vacuum experiments at Ljubljana Franciscans' library (Nollet, 1751, table of figures 2)

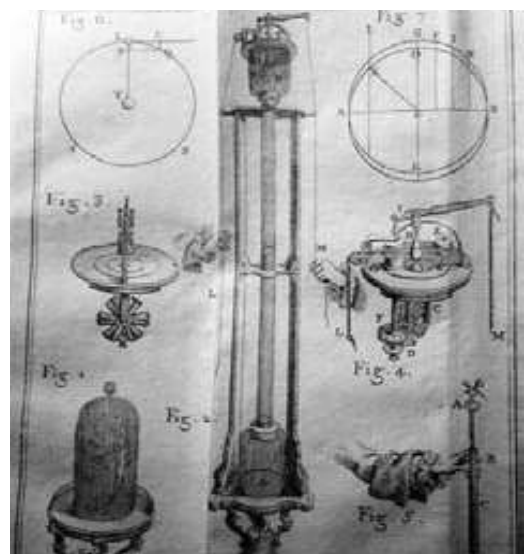

Figure 6-133: Experiments with Nollet's vacuum pump in the Library Franciscan Monastery in Ljubljana (Nollet, 1755, table of figures 1)

The Ljubljana Franciscans used the books of Gruber's professor and a close Bošković's associate the Jesuit Karl Scherffer, whose works were also read at the domestic libraries of baron Erberg and Gruber's private student Žiga Zois. In 1749 and 1750 Scherffer was professor of mathematics and head of the Graz Observatory, and then a professor of mathematics with physics in Vienna. In 1763, the Archbishop of Trnava officially proclaimed the new Scherffer's book on Bošković's Physics for the textbook in Trnava. In that time, Bošković's ideas of physics prevailed among the Ljubljana Jesuits. At the end of the first part of the book, Scherffer published 155 images in unnumbered groups. In the last group, in Figure 138, he described the reducing the sound pressure of ringing tone in the vacuum. Figure 138 has shown a barometer, a picture 118 presented siphon, and pictures 101-105 illustrated a hydrostatic paradox.⁹²⁰ In the reprinted textbook, which was immediately purchased by the Ljubljana Franciscans, Scherffer sketched vacuum experiments, cross-section of the karst hill and the cross-section of the air gun.⁹²¹ He praised Guericke's, Boyle's, Hauksbee's and Leupold's pumps, but sketched Nollet's accomplishment with increased images of valves.⁹²² He described Halley's interpretations of experiments from the academy in Florence,⁹²³ Torricelli's baroscope⁹²⁴ and the formation of air (gases) from other substances after the experiments of Johann Theodor Eller (1689-1760 Berlin) in 1745 at the Berlin Academy and of Musschenbroek.⁹²⁵ Eller was a personal physician of the king and director of the physics section of Berliner academy. According to Hales, Scherffer calculated air density, absorption and gasification in Boyle's pump (*Antlia Pneumatica*, Αντλία Πνευματικά).⁹²⁶ According to Boyle, Scherffer described the spread of electricity through the vacuum.⁹²⁷ Besides the air and water vortices, he summed up Musschenbroek's paintings and Bošković's description of the Roman whirlwind from the year

1749⁹²⁸ which was among the first Bošković's successes.



Figure 6-134: Nollet's vacuum experiment with barometers and air gun at Ljubljana Franciscans' library (Nollet, 1751, table of figures 3, lection 7 of second part)

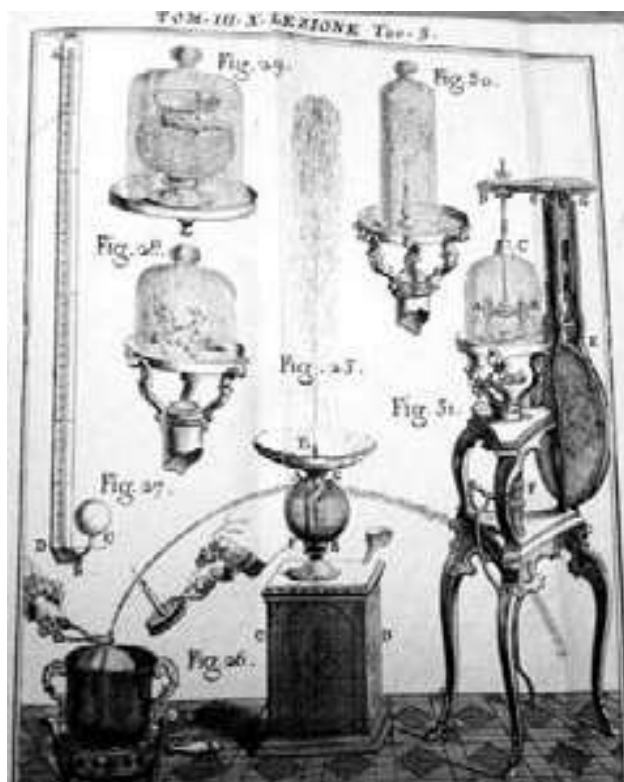

Figure 6-135: Nollet's vacuum experiments with animals in Ljubljana Franciscans' library (Nollet, 1751, table of figures 4)

⁹²⁰ Scherffer, 1753, figure 150 on table XX.

⁹²¹ Scherffer, 1753, 2:99-101, 238, Figure 91 on table X, picture of 99 on table XI; Scherffer, 1763, 2:332, Figure 109 on table XI, figure 117 on table XII.

⁹²² Scherffer, 1753, 2:239-241; Scherffer, 1763, 2:333-335.

⁹²³ Scherffer, 1763, 2:350.

⁹²⁴ Scherffer, 1763, 2:357.

⁹²⁵ Scherffer, 1763, 2:370-374.

⁹²⁶ Scherffer, 1763, 2:421-433.

⁹²⁷ Scherffer, 1763, 2:310-311.

⁹²⁸ Scherffer, 1763, 2:565.

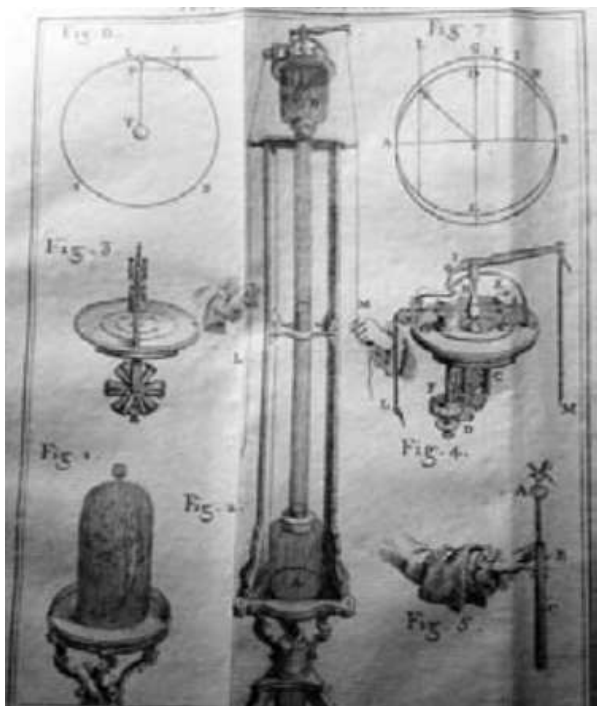

Figure 6-136: Nollet's vacuum experiments at Ljubljana Franciscans' library (Nollet, 1751, Table of figures 1 lesson 6)



Figure 6-138: Nollet's experiments in Ljubljana Franciscans' library (Nollet, 1751, right half of the table of figures 3, part three).



Figure 6-137: Nollet's experiments in Ljubljana Franciscans' library (Nollet, 1751, table of figures 3, part three)

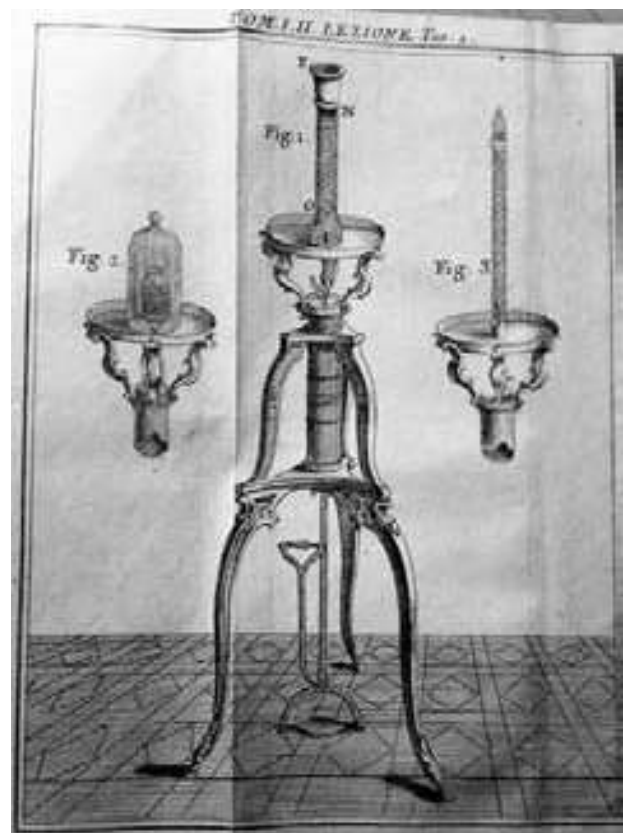

Figure 6-139: Nollet's vacuum pump at Ljubljana Franciscans' library (Nollet, 1751, Tom 1, table I Lesson 3).



Figure 6-140: Nollet's vacuum pump at Ljubljana Franciscans' library (Nollet, 1751, Tom 2, table I Lesson 8).

Franklin's (and therefore also Scherffer's) opponent Nollet has enabled the Ljubljana Franciscans to read one of the most modern experimental manuals full of experiments with vacuum technics of 18th Century. Exceptionally, the Ljubljana Franciscans selected in addition to a two-part French edition of 1744 also the four-part Italian Venetian edition of 1751 with its last fourth part printed previously in 1749. The French edition of Nollet's work bound in reinforced cowhide brown leather was used by Ivo Bonelli (OFM; d. 22. 9. 1809 Ljubljana), the Italian issue bound in pigskin was used by the procurator and Ljubljana lector of philosophy Vincent Marjašič (Mariaschitz). Both must have been particularly impressed by the tenth and eleventh experiments of the second part of the third book with animals and fish in the vacuum.⁹²⁹ The pater Ivo Bonelli was chaplain, a priest of the Tridentine diocese and the assistant professor (Suplent) of mathematics at the University of Innsbruck. He died of the fever which he caught when he gave the Sacrament of Anointing of the Sick to the French soldiers at the hospital at the time of the Illyrian provinces.

⁹²⁹ Franciscans of Ljubljana diary, 1658/1660 – 1828, year 1766, folio 9; Nollet, 1751, 3:191-195, X lezione tavola 1-6, XI lezione Tavola 1-2, 4.

In his second book, Nollet reported on the behavior of the water in the vacuum.⁹³⁰ He believed in a small compressibility of water without knowing of Herbert and Ambschell's experiments in Vienna and Ljubljana.

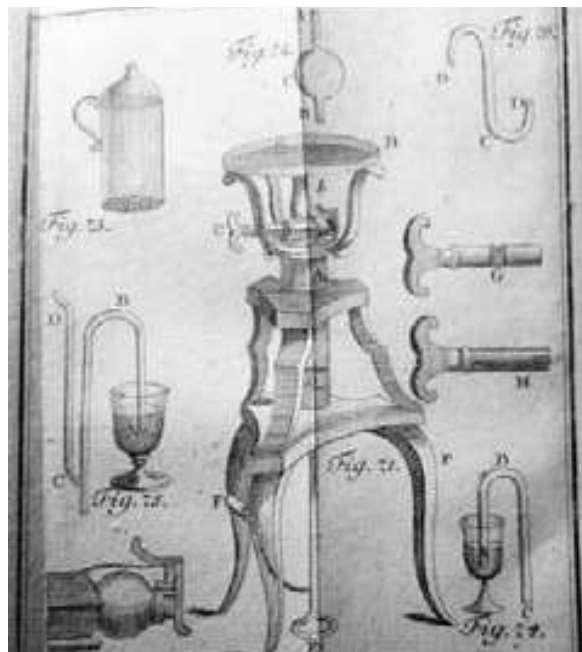

Figure 6-141: De le Fond's vacuum pump at Ljubljana Franciscans' library (Fond, 1785, table of figures 13).

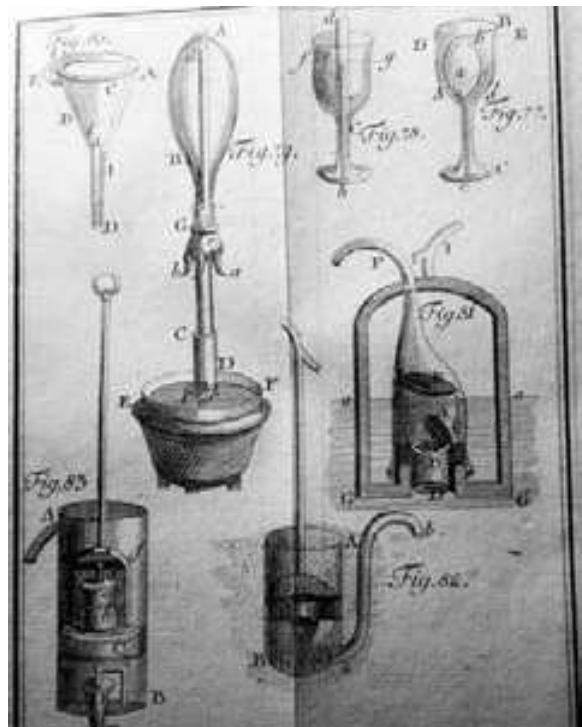

Figure 6-142: De le Fond's vacuum experiments at Ljubljana Franciscans' library (Fond, 1785, table of pictures 14).

⁹³⁰ Nollet, 1751, 2:97, VI lezione Tavola 1.

The Ljubljana Franciscans bought the book of Nollet's Parisian successor in the chair of experimental physics at the Collège Louis le Grand Sigaud de la Fond in the German translation of 1785, where he served his readers with first-class illustrated vacuum experiments at the beginning of the book. He supported them with a well-founded history of Guericke's and other achievements.

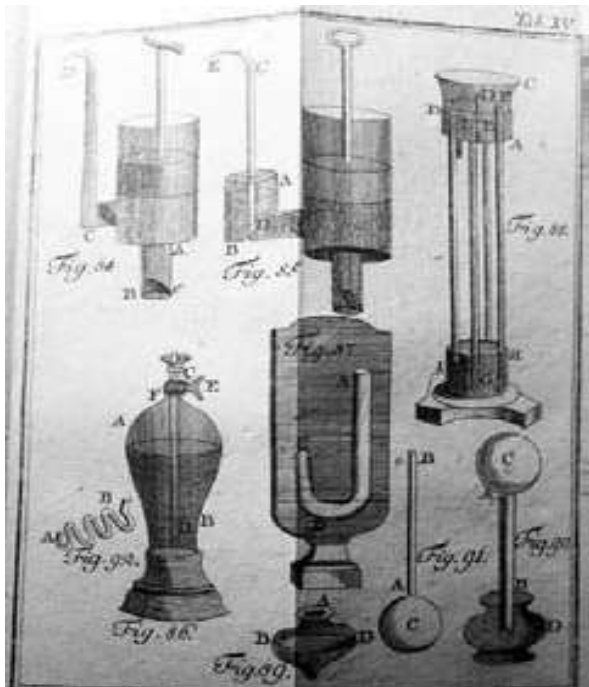

Figure 6-143: De le Fond's barometers at Ljubljana Franciscans' library (Fond, 1785, table of pictures 15).

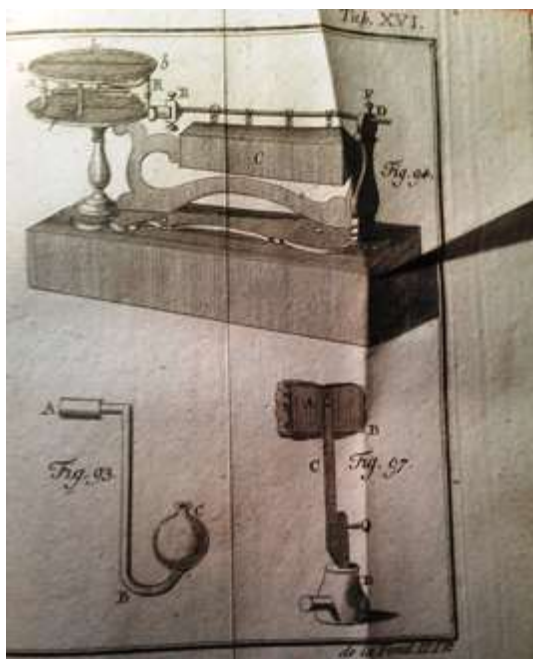

Figure 6-144: De le Fond's experiments at Ljubljana Franciscans' library (Fond, 1785, table of pictures 16).

The Frenchman of the order of Minims at Roman church of the Santissima Trinità dei Monti (La Trinité-des-Monts) Jacquier taught as the Roman Lyceum (today's University *La Sapienza* in Rome) after the ban of the Jesuits in 1773. Together with his religious co-brother Seur he published a commented translation of Newton Principles in Geneva in 1739-1742. It was also used by Novo Mesto Franciscans. Jacquier has been lecturing physics in Turin since 1745, and since 1763 he has taught physics and mathematics the duke of Parma. He also lectured in the City Roman College of the *propaganda Fide* established as the support of missionary activities in 1622. It was related with Inquisition⁹³¹ but not that much scary as it mostly cared about the missionaries. Jacquier translated whole Taylor's book into Italian language: he also relied on Newton ideas. He published a physical textbook for students of theology, which was reprinted by Graz Jesuits (1766) and was used for the courses of Jesuit philosophical studies. Three years after the printout, in 1765 the last two parts with special physics and mathematics were purchased by Ljubljana Franciscans. Only two of its three volumes are preserved without logic and general physics. After "General physics" with mechanics, Jacquier in the second part of "Special Physics" published the chapter (*Sectio*) on fluid(s), Light with Fire (II), astronomy (III) and Geography (IV). In section of the fluids he described air and summed up Torricelli's experiments with barometers with vacuum pumps included.⁹³² As an enthusiastic Frenchman he specifically praised Pascal's vacuum experiments.⁹³³ The book was complemented by mostly geometric less attractive sketches. He used Newton's law of attraction, while he mostly ignored Bošković's supplementation at small distances. Jacquier's Letters about Hydrostatics were evaluated in the Venice physiocratic newsletter, which was also read by Ljubljana natives.⁹³⁴

Jan Ivanchich (Ján) and Antal Reviczky described many uses of mathematics in the spirit of the Maria Therese's Reform. Ivanchich studied at the Jesuitical Universities of Vienna and Trnava. Between 1755-1761 he taught philosophy at the

⁹³¹ Trane, 1993, 84.

⁹³² Jacquier, 1762, 5:58.

⁹³³ Jacquier, 1762, 5:66.

⁹³⁴ *Giornale d'italia, Agricultura*. Venezia: B. Milocco, 1766, 80 (NUK-5341).

University of Trnava, and later became a professor of theology at the University of Vienna. In 1770 he became Abbot in Trnava (Nagyszombat). With the group of Trnava professors, he departed from scholastic philosophy and developed Regnault's Cartesian theory after the first Theresian reforms announced in 1753. He wrote several philosophical works, a textbook of physics and an optical dissertation.



Figure 6-145: De le Fond's experiments using distillation at Ljubljana Franciscans' library (Fond, 1785, table of pictures 17).

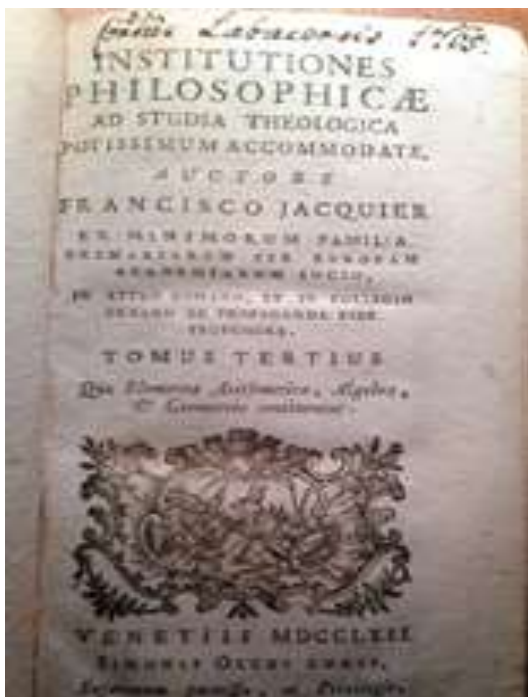

Figure 6-146: The title page of Jacquier's philosophy at Ljubljana Franciscans' library (Jacquier, 1762)

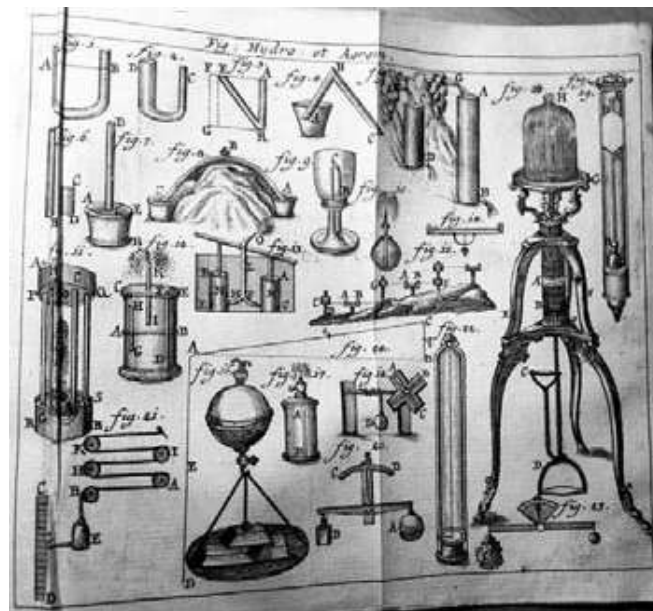

Figure 6-147: Weighing of force which holds together the Magdeburg hemispheres and Vacuum pump of Trnava Jesuits From Year 1752 in Ljubljana Franciscan library (Jesuits of Trnava (Ivanchich and Antal Reviczky), 1752, Images on the end of book, hydrodynamics and aerodynamics, Figures 16 and 24); F.



Figure 6-148: Weighing of force pressing on vacuum and vacuum pump in Jaszlinszki's general physics in Ljubljana Franciscan library (Jaszlinszky, 1756, First table of images on the end of General Physics, Figures 10 and 6); F.



Figure 6-149: Pressed Guericke's Magdeburg hemispheres and electric glimmering of vacuum containers in Jaszlinszki's general physics in Ljubljana Franciscan library (Jaszlinszky, 1756, Second table of images on end of general physics, figures 19 and 17); F.



Figure 6-150: Jaszlinszky's experiments with magnetic field lines (Jaszlinszky, 1756, table of figures 6)

The Cartesian Reviczky was Ivanchich's colleague at the University of Trnava. In 1757 and 1758 he published *Elementa philosophia naturalis* there. In

the second part of the book, he dealt with specific (experimental) physics and described the movement of animals according to Descartes and Galileo's friend Giovanni Alfonso Borelli (* 1608; † 1679).

Ivanchich and Reviczky knew from Galileo's researches that the vacuum can raise water 32 feet high. They determined the height of atmosphere and for further reading they recommended mainly the works of their religious co-brothers Jesuits: Joseph Falck's (d. 1737) *Mundus Aspectabilis Philosophice Consideratus* from year 1740, which Ljubljana Jesuits purchased seven years after printout, the books of French Jesuit Milles De Chales' (Dechaes) and the Jesuit Lana from Brescia. Ivanchich and Trnava Jesuits researched the elastic options of air compressed in container. Lana's described it in the second part of his famous book, which Ljubljana Franciscans also had.

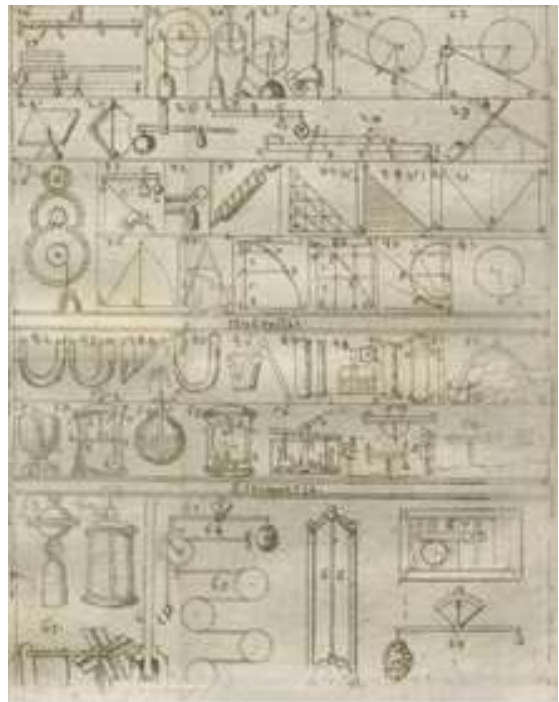

Figure 6-151: Vacuum pump of Trnava Jesuits (Ivanchich, Reviczky) of the year 1752 (Jesuits of Trnava (Ivanchich, Reviczky, Jesuit professor of mathematics in Freiburg and Dillingen Joannes Baptista Planck, Gautruche, 1752, part 2, table 2 of illustrations, pictures 59-60 at the end of the book).

Ljubljana Franciscans also read the work of Trnava Jesuits on Mathematical sciences, describing Heron's fountain, elasticity of gases and Magdeburg hemispheres with a radius of 100 lines and a volume of 7850 of today unknown units. The book has not been signed. Its writers were Jan Ivanchich and Antal Reviczky. Ivanchich and

Reviczký published about the use of mathematics in the spirit of Theresian Reforms.

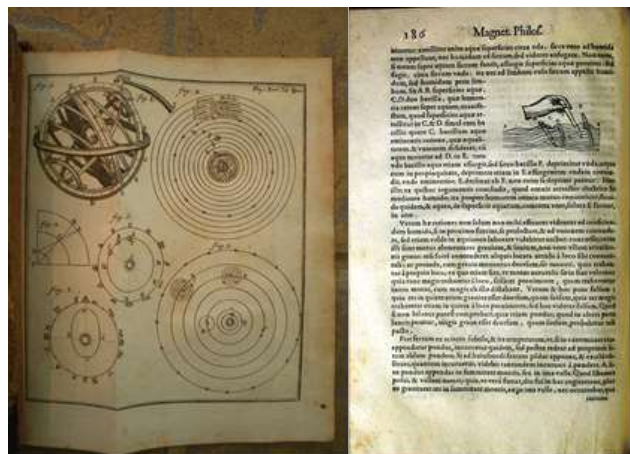

Figure 6-152: Copernican system by Jaszlinszki's Special Physics in Ljubljana Franciscans' library (Jaszlinszky, 1756, table of pictures at the end of the book)

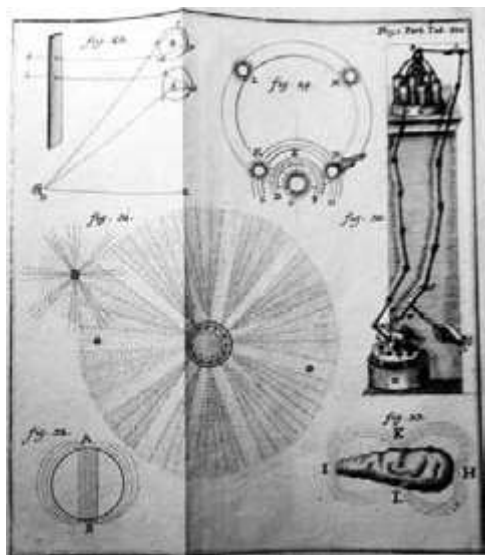

Figure 6-153: Jaszlinszky's experiments with electrostatics in Ljubljana Franciscan library (Jaszlinszky, 1756, table of images 5); F.

Ivanchich and Reviczký had listed devices suitable for determining the characteristics of the air, including Boyle's pump called *Antlia pneumatica*. Torricelli's barometer was drawn on the nineteenth figure, at the eighth picture Ivanchich and Reviczký introduced a siphon laid over the hill. On the thirteenth picture there was a hydraulic pump. The reader was advised to consult mainly the *Technica Curiosa, Magia Piriotechnica* and the acoustics of the Jesuit Gaspar Schott, who first described the Guericke's vacuum experiment. He seemed interesting in de Chales's *Hydrostatica*,

Lana's invention of the vacuum balloon and a description of the echo in *Misurgia* of Schott's teacher Athanasius Kircher.⁹³⁵

In their conclusion, the Trnava Jesuits with Ivanchich and Reviczký onboard afforded eight tables full of pictures. At last figure they supported their chapter on Hydrometric and Aerometry with figure number 20 resembling Boyle's pump, and with the Figure 16 they added the weighted vacuumed hemispheres.

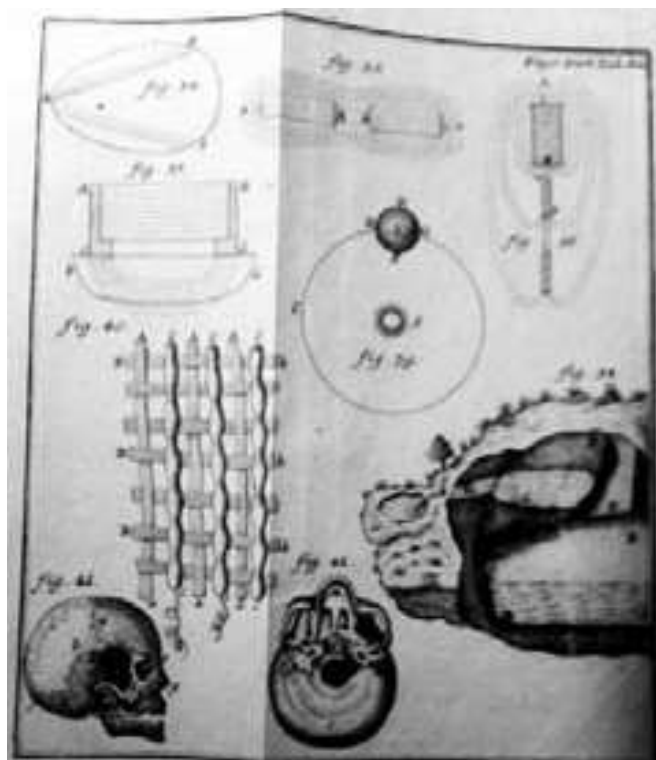

Figure 6-154: Jaszlinszky's experiments with magnetic fields of forces (Jaszlinszky, 1756, table of images 6); F.

Ivanchich and Reviczký were soon supplemented by their associate András Jaszlinszky. Later in the year 1771 Jaszlinszky became a rector of Trnava University. Today's Ljubljana book of professor of physics András Jaszlinszky (* 1715 Szina; SJ D. 1783 Rozsnyó) was the property of Franciscans from Kostanjevica above Gorizia a century and a half ago in 1862. According to proprietary records, it appears that the work was exchanged by students in their late teenage years. The student Francis Xaver Joseph Winperger in 1759, the student of poetics in Ljubljana in 1801 Jožef Skaria (Scaria, Škarja) from Vipava in 1805, and the student of

⁹³⁵ Ivanchich, Reviczký (The Jesuits of Trnava), 1752, 223, 230, 235-239, 244.

second class of humanities in Ljubljana in 1807 Anton Kerschel (Kršl) in 1810 used the book one after another during their higher studies. Kerschel attended his lectures of physics in the era of Illyrian provinces to become a surgeon and pioneer of vaccinations in Ljubljana and Gorizia.

In the edition of 1761, Jaszlinszky published 800 pages of physics with 16 tables. He noted Gassendi, Boerhaave, Boyle, Malpighi, Linnaeus, Harvey, Loewenhoek, Voltaire, Descartes and Francesco Redi (d. 1698) who wrote at last four times to his antagonist, one of the first vacuum researchers Athanasius Kircher.⁹³⁶

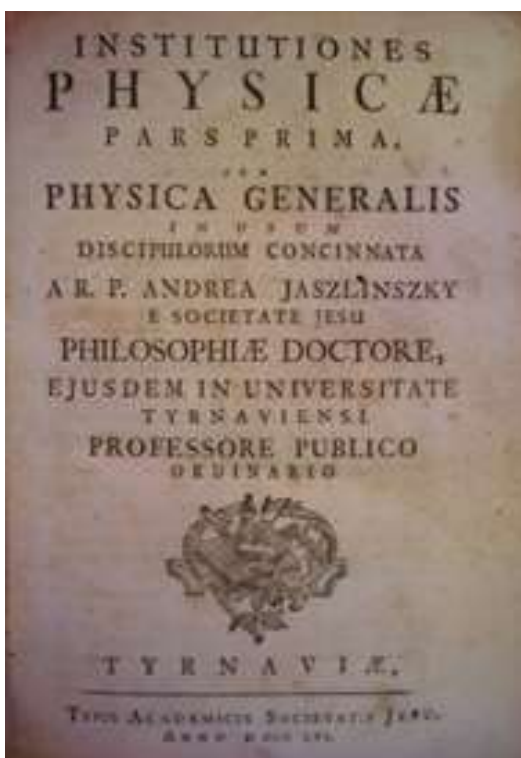

Figure 6-155: The title page of Jaszlinszky's textbook of general (theoretical) physics in Trnava (Jaszlinszky, 1756).

In the chapter on Earth Jaszlinszky was interested in electric phenomena after exemplary experiments of the academy *Del Cimento*. A special expert in electricity experiments was the Jesuit father J. Franz in the Imperial Vienna. Jaszlinszky reported the electricity in Boyle's vacuum, tested by the physician-politician Jean Jallabert (1712 Geneva-1768 Nyon in Switzerland near French border) and Maximilian Höll (Hell) in Cluj in today's Romania. Jaszlinszky described the Icelandic crystal and drew numerous experiments with electricity,

⁹³⁶ Gramatowski, Rebernik, 2001, 92.

magnets, astronomy and the underground karst lakes in the hills.⁹³⁷

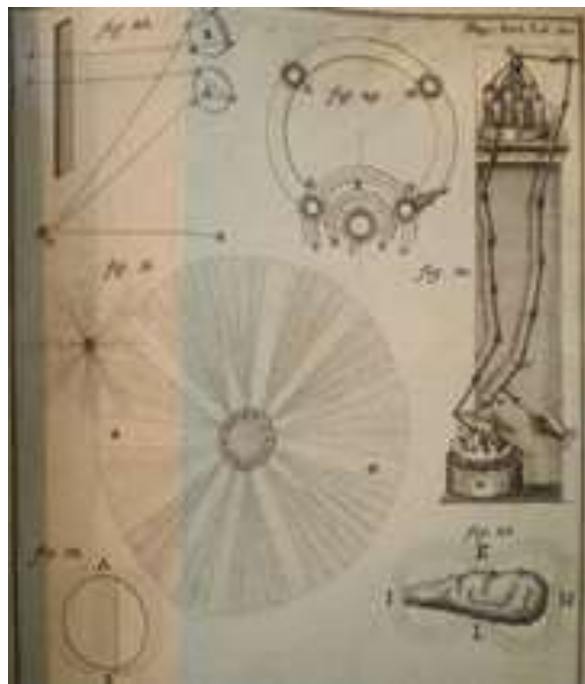

Figure 6-156: Jaszlinszky's experiments with electrostatics in Ljubljana Franciscans' library (Jaszlinszky, 1756, table 5).

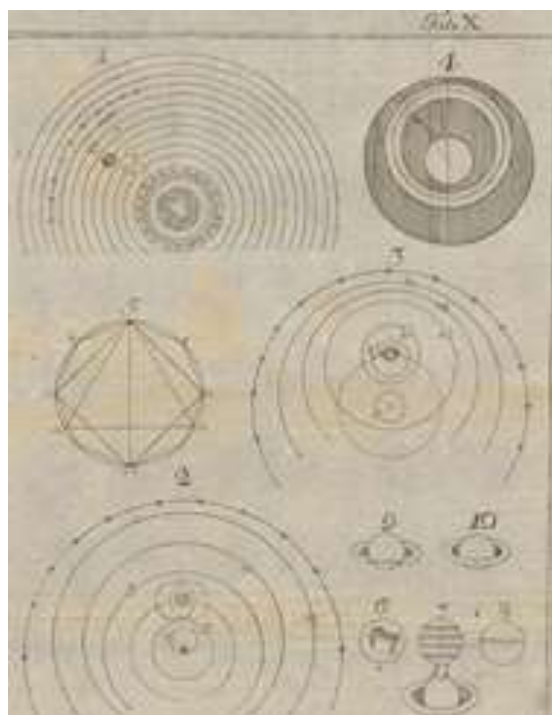

Figure 6-157: Donatus's sketch of the solar system in Ljubljana Franciscans' library (Donatus Hofmann, *Apparatus ad Philosophiam universam*, Campidonae (Kempten) 1754, table of figures 10).

⁹³⁷ Jaszlinszky, 1756, 175, 176, 177, 180, 184, 189, 191, table 6 figure 38.

Jaszlinszky summarized magnetic phenomena in the chapter on fossils. He drew some good drawings of magnets, mainly magnetic rock with field lines and three other magnets with illustrated field lines.⁹³⁸ He described electricity immediately after optics, while he discussed his magnetism besides the treatment of fossils and solids. Such fundamental diversity separated research of electricity and magnetism of those days, until Oersted and Faraday prepared their merger into electromagnetism almost a century later.

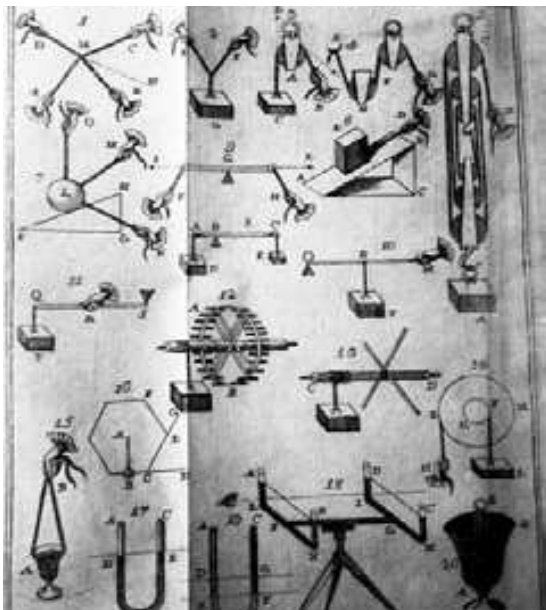

Figure 6-158: Donatus' mechanics and barometers in Ljubljana Franciscan library (Donatus Hofmann, 1754, Table of Images 1); F.

The professor of theology and philosophy as well as rector in Kempten in Swabia the Piarist Donatus Hofmann a Transfiguratione Christi Domini (Donat, b. 1703 Lübschütz in upper Silesia; d. 1783) arranged up his whole Introduction to the apparat of Philosophy in the form of questions and answers. His work was read by Ljubljana Franciscans, as well as by Škofja Loka Friars Minor Capuchin. Hofmann filled his first part of book with physics as Tomus III, while the second part was devoted to ethics as Tomus IV. Hofmann described the Horror vacui⁹³⁹ which Galileo, Pascal and his brother-in-law, Francisco Perera, and Torricelli annihilated in their days. Hofmann published the sizes of Torricellian devices measured in the fingers or inches.⁹⁴⁰ The alleged

⁹³⁸ Jaszlinszky, 1756, 208; Table 5 Figure 33; Table 6 figures 35-37.

⁹³⁹ Donatus Hofmann, 1754, 1:65

⁹⁴⁰ Donatus Hofmann, 1754, 1:66

Cartesians from Minims' order theologian expert of gnomonic and perspective Plato's supporter Emmanuel Maignan (Magnan, 1601-1676 Toulouse)⁹⁴¹ and Cl. Pluchio (Noel Antoine Pluche) opposed the peripatetic fans regarding natural bodies.⁹⁴² The Jesuit De Lana used to be their very famous model.⁹⁴³ Donatus Hofmann was a fan of the etheric substance in vacuum, although Gassendi and Newton criticized those concepts against Cartesians⁹⁴⁴ with Newtonian attractive force.⁹⁴⁵ The puzzle called *Rebus Aerometricus* was resolved with a barometer filled with mercury.⁹⁴⁶ Donatus Hofmann also described the *Lacrima Batavica*,⁹⁴⁷ hermetically sealed tubes,⁹⁴⁸ glass tubes formed like an egg,⁹⁴⁹ (Boyle's) Antlia as a vacuum pump,⁹⁵⁰ vacuum-vessel with poor bunnies used for experiments,⁹⁵¹ and Heron's fountain.⁹⁵² Donatus Hofmann respected the opinions of great thinkers as were Copernicus, Tycho, Ptolemy⁹⁵³ because he was interested in nature of light made of the substance of ether.⁹⁵⁴ Donatus Hofmann listed Hauksbee's observations, achievements of Florentine philosophers centered in their famous Academy, (Boyle's) experiments with his *Antlia Pneumatica*, Bernoulli's observation of gravity,⁹⁵⁵ electricity,⁹⁵⁶ magnetism,⁹⁵⁷ air,⁹⁵⁸ and even the possibility of transmutation of metals⁹⁵⁹ which looked like an alchemy of monk Hofmann's own priestly name Transfiguratione Christi Domini. Donatus Hofmann was even interested in working abilities of cannons and howitzers⁹⁶⁰ which brought money into the pockets of those days even if it was not really in the mood of the Catholic monk.

⁹⁴¹ Donatus Hofmann, 1754, 1:67.

⁹⁴² Donatus Hofmann, 1754, 1:97.

⁹⁴³ Donatus Hofmann, 1754, 1:106.

⁹⁴⁴ Donatus Hofmann, 1754, 1:107-108.

⁹⁴⁵ Donatus Hofmann, 1754, 1:113.

⁹⁴⁶ Donatus Hofmann, 1754, 1:152, tab II Figure 14.

⁹⁴⁷ Donatus Hofmann, 1754, 1:155.

⁹⁴⁸ Donatus Hofmann, 1754, 1:156, tab II, figure 18.

⁹⁴⁹ Donatus Hofmann, 1754, 1:157, tab III, figure 4, fig 56.

⁹⁵⁰ Donatus Hofmann, 1754, 1:158, table 4, figure. 15.

⁹⁵¹ Donatus Hofmann, 1754, table IV figure 3-4.

⁹⁵² Donatus Hofmann, 1754, 1:159.

⁹⁵³ Donatus Hofmann, 1754, 1:177.

⁹⁵⁴ Donatus Hofmann, 1754, 1:187.

⁹⁵⁵ Probably Daniel Bernoulli (Donatus Hofmann, 1754, 1:188).

⁹⁵⁶ Donatus Hofmann, 1754, 1:191 table VII figures 1-10 after mixed and erroneously bind pages.

⁹⁵⁷ Donatus Hofmann, 1754, 1:197.

⁹⁵⁸ Donatus Hofmann, 1754, 1:236.

⁹⁵⁹ Donatus Hofmann, 1754, 1:314.

⁹⁶⁰ Donatus Hofmann, 1754, 1: Tab VIII.



Figure 6-159: Air rifle and barometers by Donatus in Ljubljana Franciscans' library (Donatus Hofmann, 1754, table of figures 3).

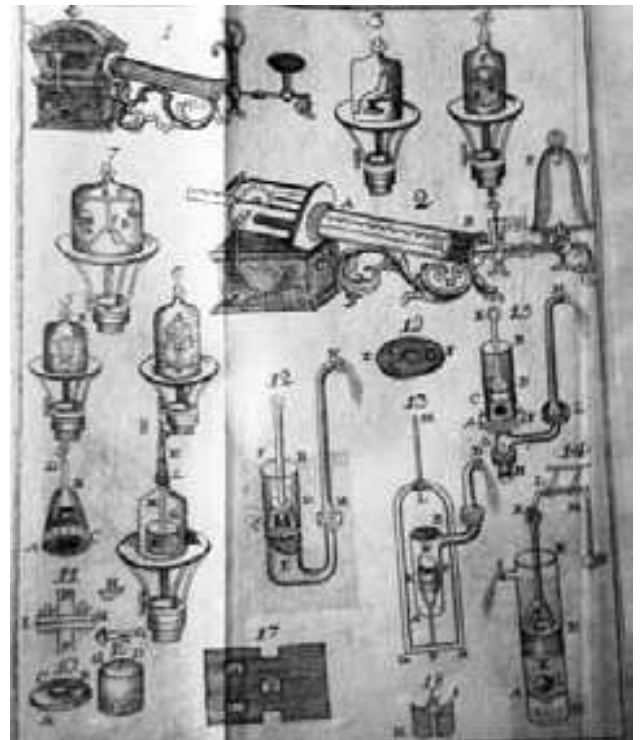

Figure 6-161: pumping and experimenting with animals by Donatus in Ljubljana Franciscans' library (Donatus Hofmann, 1754, table of figures 4).



Figure 6-160: Donatus' barometers and siphons in Ljubljana Franciscan library (Donatus Hofmann, 1754, Table of images 2); F.

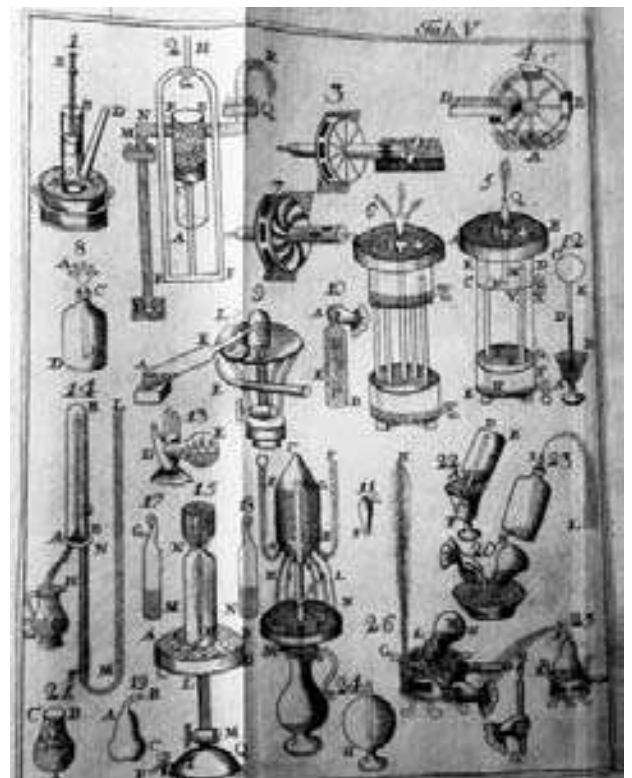

Figure 6-162: Donatus' vacuum pumps at Ljubljana Franciscans' library (Donatus Hofmann, 1754, table of pictures 5).



Figure 6-163: Donatus' Experiments in Ljubljana Franciscans' library (Donatus Hofmann, 1754, table of figures 6).



Figure 6-164: Donatus' experiments with magnets and electricity at the Ljubljana Franciscans' library (Donatus Hofmann, 1754, table of pictures 7).

The former Ljubljana Jesuit teacher Biwald published dozens of textbooks of Bošković's physics which the Franciscans of Ljubljana also used. Biwald described the porosity and virtual mutual penetration of bodies by Musschenbroek's

experiments with vacuum pump nicknamed *Antlia Pneumatica*.⁹⁶¹ Biwald added a *Scholium* borrowed from Musschenbroek and by clerk Guillaume Hombergius' (William Homberg, 1652 Batavia (Jakarta)-1715 Paris) notes in *Memories de l'Academie Royale* anno 1693 page 28. In 1674 Homberg as an advocate in Magdeburg met Guericke who persuaded him to become a scientist. In 1682 Colbert invited Homberg to Paris where Homberg became a Catholic and the second pensioner-chemist of the academy in 1699. Homberg loved the alchemistic transmutations chrysopoeia (χρυσοποιία, *khrysopoia*) while he also published a lot about vacuum in the Parisian *Recueil de l'Académie des Sciences*.

As a devoted Bošković's fan, Biwald proved the relevance of Bošković's curve with pictures as well as with words.⁹⁶² In 1788 the preacher, honorable lector, and priest Alan Makovic (Markovič, Marcobitz, Makovič, Makoviz, * 1748; OFMobs 1764; D. 26/27. 6. 1803 Novo Mesto) used Biwald's third edition of 1774. On 25. 7. 1767 in Novo mesto Makovic received his first tonsure as a Franciscan. On 23. 9. 1770 Makovic left his Ljubljana convent to become a preacher sub-deacon.⁹⁶³ Alan Makovic used to be the manager of the parish Raka. Later in 1796 he unsuccessfully tried to get Kovor by Tržič parish in competition with another Franciscan, Valentin Vodnik.

Makovic subsequently wrote his marginal Latin notes with a pencil into Biwald's book of 1774. Makovic stated at the paragraph of Guericke's vacuum experiments that Guericke's pump could be used for pumping of water (*implatur aqua*). It's a pity that we are not sure now about the eventual Makovic's success. After Makovic's death, his bookplate in the first volume of Biwald's book was crossed out, and in the second volume Makovic's bookplate was hid with the help of red wax or adhesive. The leaves are full of sketches of people's profiles, linguistic exercises, Latin theorems and similar studies, which, however,

⁹⁶¹ Biwald, 1774, 1:86 figure. 1 and figure 2.

⁹⁶² Biwald, 1774, 1: 218 Ffigure. 74-78 of table 8.

⁹⁶³ Fr. Alanus Marcobitz, ordinis sancti Francisci minorum, ad primam tonsuram et quatuor minores ordines... F. Makoviz Alanus, ordinis minorum sancti Francisci reformatorem, conventus Labacensis dimissus, ad subdiaconatum, titulo professionis religiosae (Jure Volčjak, *Ordinacijska protokola goriške nadškofije 1750–1824*, 2nd part: 1765–1824, Ljubljana 2012, pp. 22, 120).

might not have much of a direct contact with Biwald's narrational substance.

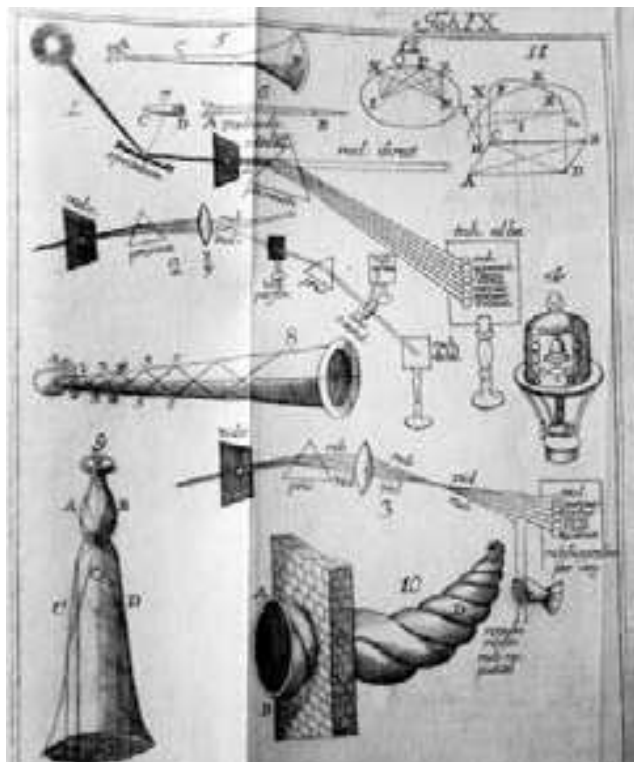

Figure 6-165: Donatus' experiments with vacuum pump and light at Ljubljana Franciscans' library (Donatus Hofmann, 1754, table of figures 9).

Benvenuto Philippitsch (Filipič) used another copy of Biwald's textbook edition of 1774. Benvenuto Philippitsch certainly was a fan of modern physics as he also used another Pal Mako's Jesuitical textbook *Compendiaria Matheseos Institutio* in Viennese edition of 1771, as well as Johan Ivančič's (Ivancisc, Ivanchich, * 1722) *Institutiones logicae* issued in Trnava in 1767, which he got from philosophy student of the first year Michaelis Hartl. On 12. 7. 1771 in Gorizia Filipič received his first tonsure and forth minor orders as a Franciscan in Sveta Gora above Gorizia. On 6. 3. 1773 he became a deacon still in Sveta Gora above Gorizia.⁹⁶⁴ In 1776, he graduated

⁹⁶⁴ Jure Volčjak, *Ordinacijska protokola goriške nadškofije 1750–1824*, 2nd part: 1765–1824, Ljubljana 2012, pp. 148–149. Sixteen years old Jesenice citizen Lucas Herbitz studied rhetoric in Ljubljana in 1770 while his alleged elder brother Franc Borgia Herbitz did the same two years earlier (Črnivec, 1999, 279, 282).

⁹⁶⁴ Orožen, Ignacij, 1887. *Das Bisthum und die Diözese Lavant : mit den bis zum Jahre 1854 dazu gehörig gewesenen Seelsorgestationen, als: Peilenstein, Drachenburg, St. Peter in Fautsch, St. Maria in Zagorje, St. Anna in Prevorje, St. Margarethen im Markte Montpreis, St. Maria in Dobje, Hörberg, St. Peter unter Königsberg, St. Lorenzen in der*

in theology with his classmate Joanne Damasceno Herbitz (baptized Lucas, * 1754 Jesenice) in the class of Kastul Weibl (Caztallus, Castul Waibl, baptized Janez, 1741 Novo Mesto-1805). Herbitz was later a substitute priest in Mošnice. Certainly, the Franciscans could put their bookplates in the textbooks of physics or mathematics as the students of philosophy or later, as the teachers of the same stuff. Their preferred textbooks tell us much about their inclinations towards Copernicans, Cartesians, Newtonians, vacuum techniques or Bošković, but their eventual marginal notes in textbooks could be much more narrative.



Figure 6-166: Donatus' experiments using distillation at the Ljubljana Franciscans' library (Donatus Hofmann, 1754, table of figures 8).

The students used Biwald's textbooks in Ljubljana and Graz including the Škofja Loka native Martin Prenner and the Venetian count Mario Pozzo. Both printed their exam theses with famous Biwald's book *Physica Particularis* of 1769. Prenner also used the help of the Idrija mine director count Inzaghi to promote a reprint of Giacomo Bartholomeo Beccari's book. Pozzo was already a count himself, so he looked for higher patrons, in fact for the highest of them all. Pozzo devoted the

Krajina (bei Wisell), St. Nikolaus in Felddorf, Windisch-Landsber, p. 469.

second edition of the second part of Biwald's textbook *Physica Particularis* of 1769 to the empress Maria Therese together with his fifty-two exam theses of philosophy with physics, ten theses of ethics, fifteen theses of algebra, and ten theses of geometry. The noble family Pozzo had its main headquarters in Turin and 80 km southwest in the city of Biella. Soon after its printing Franc Anton von Breckerfeld (1740 Altenburg (Stari Grad) by Novo Mesto-1806 Ljubljana) acquired the book of Biwald and Pozzo in 1771. Franc Anton von Breckerfeld inherited several other mathematical books from his father Janez Žiga von Breckerfeld (1689-1760) and became Linhart's helper in collecting the historical as well as natural historical local Carniolan materials. Franc Anton von Breckerfeld's copy of Biwald's book later acquired the seal of Novo Mesto Franciscans and they passed the item to their Ljubljana religious co-brothers.

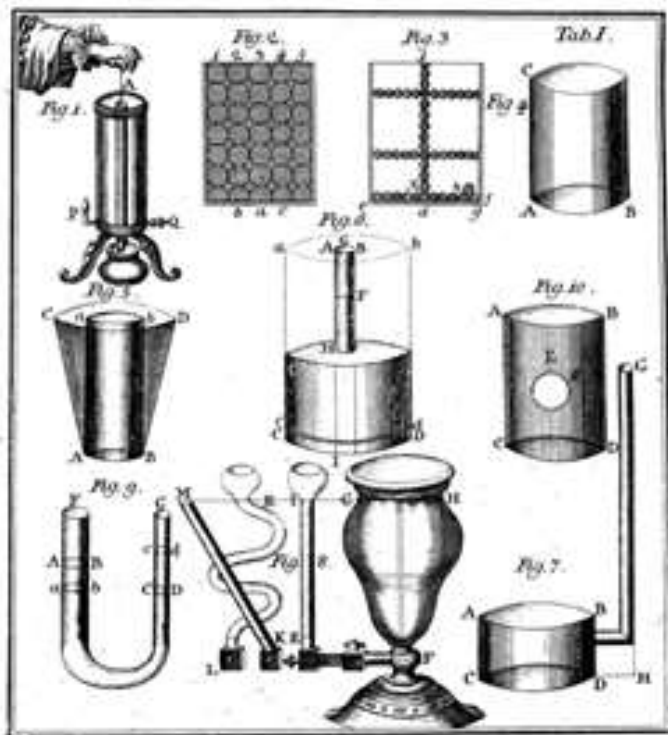

Figure 6-167: The first part of the Biwald's images of experiments with barometers in Ljubljana Franciscans' library (Biwald, 1774, first table of images at the end of the first book).

Johann Gabriel Doppelmayr's pupil Georg Friederich Brander (b. 1713 Regensburg; d. 1783 Augsburg) founded his own shop of scientific facilities in Augsburg in 1737. The Ljubljana Franciscans also had Doppelmayr's translation of Bion's book printed in the year 1712. The Jesuits

of Ljubljana acquired many Doppelmayr's scientific astronomical instruments in 1755. From 1765 to 1776 Brander has corresponded on research aids with Johann Heinrich Lambert. In 1774, Brander published twenty sketches of vacuum devices which were among the most useful in the collection of Ljubljana Franciscans. He relied on Pieter's father Johann van Musschenbroek's successes.⁹⁶⁵ Brander was not just selling pumps, but he also offered to his buyers the appealing experiments with vacuum. He was interested in the operation of the magnet in the vacuum.⁹⁶⁶

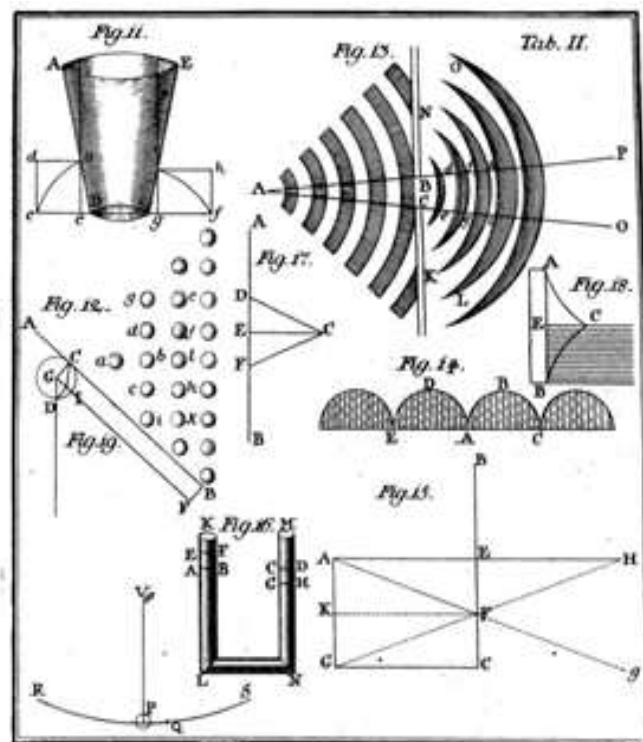

Figure 6-168: The second part of Biwald's images of experiments with barometers in Ljubljana Franciscans' library (Biwald, 1774, second table of paintings at the end of the first book).

In the early 19th century, the Ljubljana Franciscans in Vienna purchased several modern manuals for the handling of vacuum technique and maybe even the vacuum pumps for their students. After visiting France and Petersburg in 1769, Johann Jakob Ebert became a professor of mathematics at the Protestant Wittenberg University. Despite his Protestant pedigree, his books were a great match for of Ljubljana Franciscans' contemporary learning.

⁹⁶⁵ Brander, 1774, 9, 18-19.

⁹⁶⁶ Brander, 1774, 29.

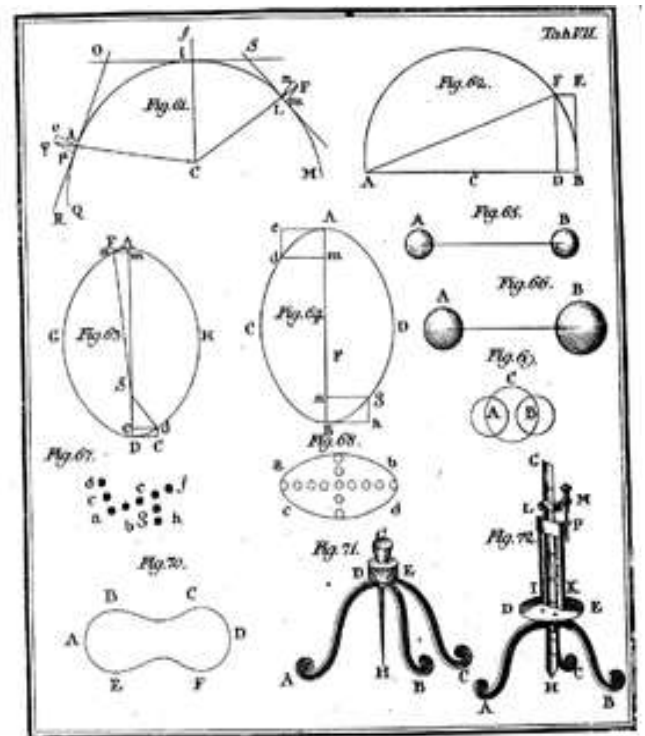
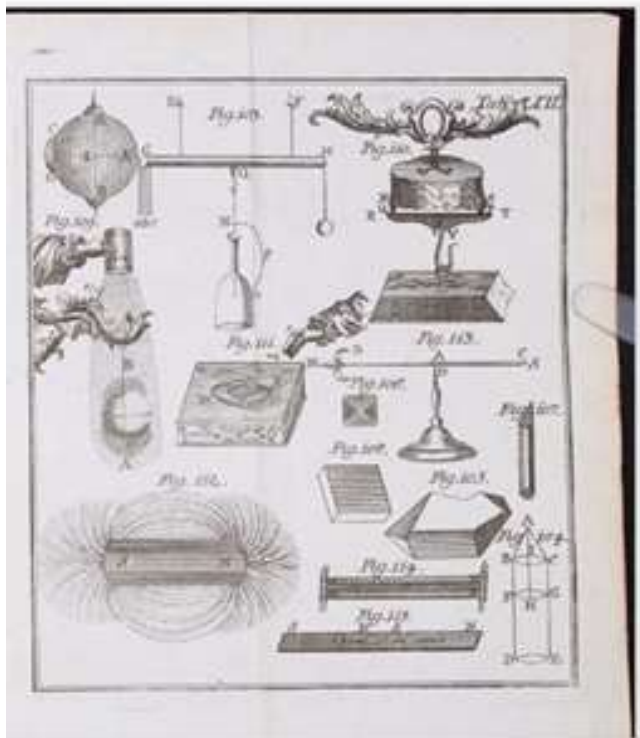

Figure 6-169: Biwald's experiments with Vacuum hemispheres and electricity at Ljubljana Franciscans' library (Biwald, 1774, table of figures XII at the end of the first book).

Figure 6-171: Biwald's vacuum recipients at the bottom of the picture at Ljubljana Franciscans' library (Biwald, 1774, table pictures 7 at the end of his first book).

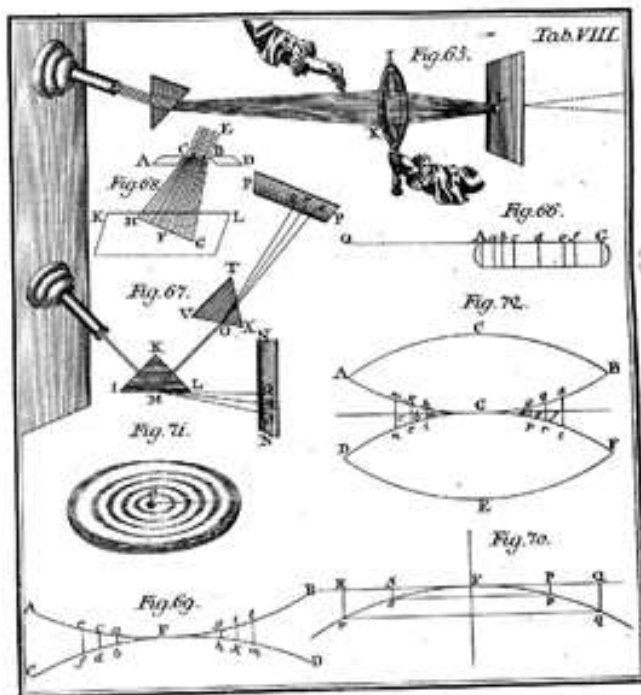

Figure 6-170: Biwald's optics in Ljubljana Franciscans' library (Biwald, 1774, part 2, table 8 of pictures at the end of the second book).

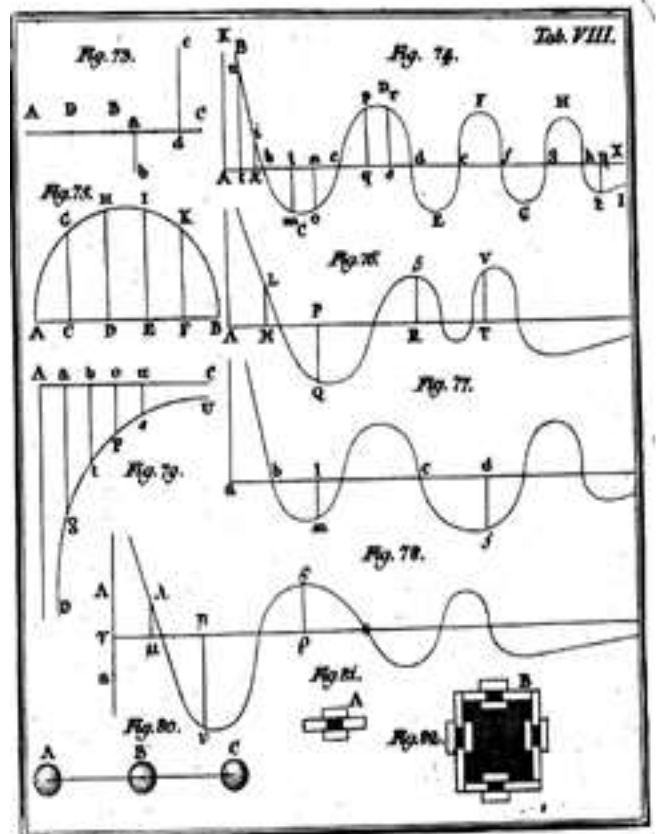

Figure 6-172: Biwald's sketch of the Bošković's force-distance curve in Ljubljana Franciscans' library (Biwald, 1774, table pictures 8 at the end of the first book).

6.5.5 Users of the Franciscan Books about Vacuum in Ljubljana

The Bavarian Zinsmeister taught Ljubljana folks and Novo Mesto students all about vacuum experiments. How did Ljubljana Franciscans take advantage of the rich Bavarian books on vacuum technic in their library? What did they learn from them?

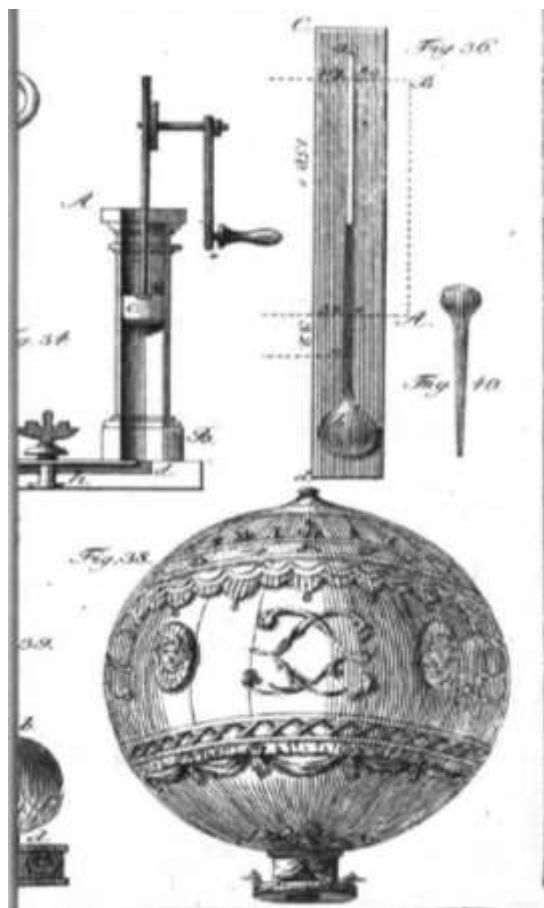

Figure 6-178: Vacuum pump and a balloon in contemporary presentation at Ljubljana Franciscans' library (Ebert, *Naturlehre für die Jugend: zur Beforderung des Beobachtungs-und Forschungsgeistes in den Geschäften des bürgerlichen Lebens*, Wien: Michael Schwarz, 1804, table 4).

The Franciscan magister Nicolò d'Orbellis (Dorbellus, d'Orbelles, OFMconv; † Around 1475 Rome) was among the first French friars minor Franciscan Conventual after the Conventuals were formally divided from those who were zealous for the strict observance of the rule as Observants; this division in the order was formally sanctioned by the Council of Constance in 1415 after their disputes were already cleared in 1407. Nicolò d'Orbellis studied in Paris, Poitiers, and Angers.

He interpreted Duns Scotus and Bonaventura.⁹⁶⁷ Prior to the year 1465—the Franciscan magister Nicolò d'Orbellis wrote his comments after he practiced as a professor of philosophy and theology at Angers University. Most of his works were published posthumous. His mathematics was first published in 1485 in Bologna while his physics was first issued in Basel in the year 1494.

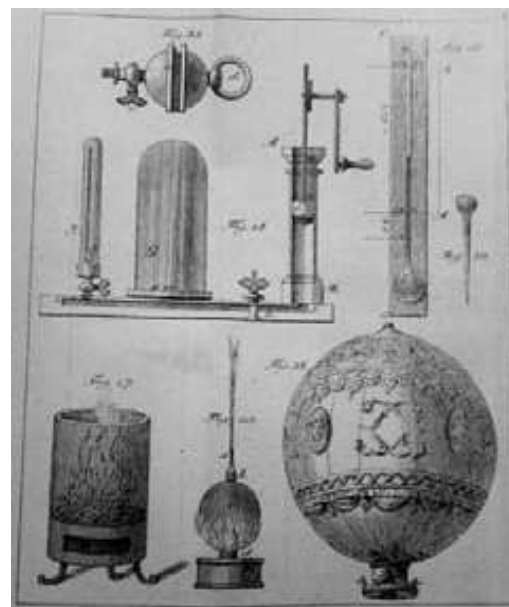

Figure 6-179: Vacuum pump and Magdeburg hemispheres in modern design of vacuum techniques at the Ljubljana Franciscans' library (Ebert, 1804, extended table 4 of a picture above).

The anthology of his books of Logic, Mathematics and Physics were reprinted in Basel in 1503, and at the latest in 1707 they became the property of Novo Mesto Franciscan Paul Novak. Novak was perhaps identical to the preacher Paschal Novak (OFM; d. 18. 2. 1764 Karlovac) or to Bonaventura Novak OFM.

The baccalaureate of philosophy holder Marko Stanzhero (Štancer, Stanzer) donated the book to Novak in the same year 1707. Marko was not of noble rank in Carniola. He was probably one of the first Baccalaureates on the just established philosophical studies of the Jesuits of Ljubljana, or he studied at the Franciscan philosophical studies as their future priest. Under Novak's signature below the title, just the part of an older proprietary entry is left. One of the older bookplates was halved during the repeated renown binding in the

⁹⁶⁷ Donnini, 2004, 151.

right top corner of the first page. Below it is the entry of the Ljubljana Franciscans of the year 17?? with cutoff last two digits. It was certainly inscribed before Škerpin's bookplates of the year 1744, which was recorded on the internal cover. Thus, the book became the property of Ljubljana Franciscans at the latest between 1707-1744. That is the only Orbellis' book in Slovenia which has ever been found. Its printing in Basel was accomplished by Jacobus Wolff de Pforzheim while Michael Furter probably printed the natural philosophy part and perhaps also mathematical part of the volume.



Figure 6-180: Title page of starting address of Orbellis' book with notes of Ljubljana reader of 16th century, supplemented by the reader in the year 1707, namely Paul Novak from Novo Mesto (Orbellis, 1503 Summule Philosophie rationalis... incipit Mathematica, 1r).

Orbellis has published basic ideas about the vacuum, which influenced the networks of early Ljubljana Franciscans. He divided his unpaginated work into a short logic with an introduction to mathematics and geometry. He followed with a longer natural history with physics summarized by Aristotelian books. There were also discussions about the soul, ethics and metaphysics, as was the habit in those days. The vacuum after Anaxagoras as an opponent Aristotle and Scotus was the cornerstone at Orbellis' interpretation of the possible movement in the empty summarized after the fourth Book of Aristotle's Physics.⁹⁶⁸

⁹⁶⁸ Orbellis, 1503 Cursus librorum Philosophiae Naturalis, 24v.

The first Ljubljana owner of the Orbellis's book from the early 16th century was allegedly the padre Thomas of Salzburg (d. 2. 4. 1541 Ljubljana), a celebrity preacher, former definitor of the province, curator, provincial minister. Because he firmly defended the Catholic faith against Lutherans and Anabaptists and many of them guided back to the bosom of the Catholic Church, his desperate opponents had twice mortally wounded him, and he finally died poisoned. The other possible owners of Orbellis's book were several times Guardian (Custos) and vicar father Angelus de Salisburgo (Salzburg, d. 9. 2. 1530 Ljubljana), the Padre Franciscus de Castelluzi (d. 26. 4. 1599 Ljubljana), the former Guardian (Custos), father Francis (d. 26. 8. 1531 Ljubljana) from the Novo Mesto, former Guardian (Custos), Padre Mihael de Achau (d. 9. 12. 1529 Ljubljana), actual vicar, former Guardian (Custos), Padre Ludwig of Slavonia (d. 11. 12. 1510 Ljubljana), a fiery preacher reverend father Jernej of Novo Mesto (d. 6. 2. 1545 Ljubljana), father Erasmus of Siebenburgen (Transylvania, d. 21. 2. 1506 Ljubljana), Padre Janez Posch (d. 3. 1. 1549 Ljubljana), former Guardian (Custos) of Ljubljana monastery father Valerian Rust (d. 17. 1. 1531 Ljubljana), former Guardian (Custos) Friar Bernardin von Ellersperg (d. 2. 7. 1505 Ljubljana), Padre Jakob of Straubing of lower Bavaria (D. 1. 6. 1513 Ljubljana), or the preacher, lector, the actual vicar, the man of deep learning and maximum modesty padre Gašper of Novo Mesto (d. 10. 6. 1509 Ljubljana).

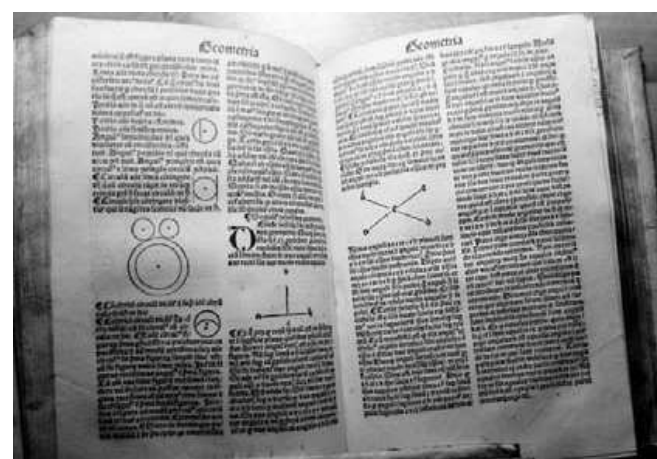

Figure 6-181: Geometric sketches on the penultimate pages of a chapter about geometry of Ljubljana Franciscan copy of the Orbellis' book (Orbellis, 1503 Summule Philosophie rationalis ... incipit Mathematica, penultimate pages of a chapter about geometry).

In the year 1491 when the Observants came in the Ljubljana Monastery, the actual Guardian (Custos) father Joahim de Freunstein (d. 10. 5. 1510 Ljubljana) became their first Guardian (Custos). Other possible writers of marginalia in the Orbellis's book were additionally the learned pater Father Bernard a Ratisbona (Regensburg, d. 1. 11. 1514 Ljubljana), or the glorious father Wolfgang of Gorizia (d. 21. 9. 1548 Ljubljana) who was a reverend old man.

In Orbellius's book, the reader wrote the headings of subchapters, and above all the clever notes in the Gothic script of early 16th century. With a little imagination, we could proclaim that marginalia design for the first bigger text on a vacuum written in Ljubljana. The clever alleged Ljubljana reader and the writer of the notes! Most of the Latin writing was devoted to Orbellis' commentary of the books of physics and, in a particular, the fourth among them, with the second chapter which was the penultimate chapter dedicated to the vacuum. So, we can have him for the first Ljubljana writer about vacuum, even if he (or even she) hasn't signed his comments after the then habit, so that we could hardly guess the writers' name. He wrote longer thoughts over the first cover and then above the cover of comments on the Aristotelian physical books. Shorter records were mostly headlined along headings of the chapters, which specifically mostly attracted the reader's attention.

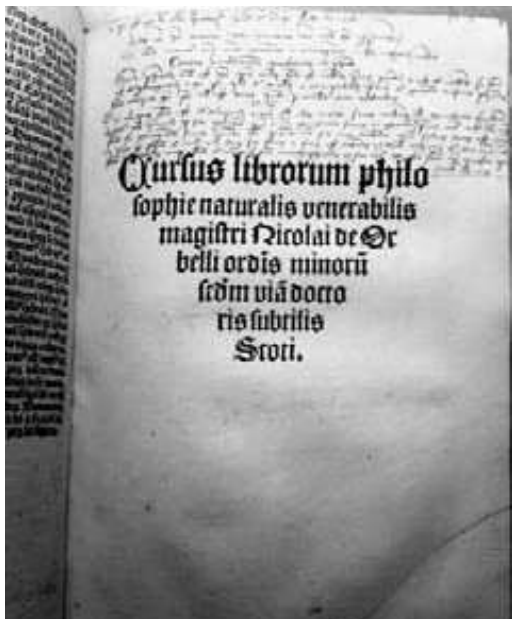

Figure 6-182: The long note of the Ljubljana reader above the Orbellis' title of the physical part of the book (Orbellis, 1503 *Cursus librorum Philosophiae Naturalis*, 1r).

Having underlined the chapter about the space just before the vacuum subsection of the fourth book, the reader wrote a longer note with two different inks.⁹⁶⁹ The first note dedicated to the vacuum has highlighted the title of the Orbellis' interpretation of pressure of air: *Inflatus Plenus Aere*.⁹⁷⁰ The next longer note refers to the Orbellis's finding that the air takes more space than water.⁹⁷¹ Then the reader used Orbellis' assumption that the movement in the vacuum would perform instantly, without delay.⁹⁷² The space is different from the position, and the vacuum is a space without bodies (*vacuum esse spacium privatum corpe*), which was particularly highlighted by the reader in his or her own note: *Locua Locato Differet*.⁹⁷³ From Orbellis' explanation, the reader specially separated the keyword about the double-refractions (*Dupliriter repugnant*) and later with a special cursor in the form of a fist and indicator outlined Orbellis' proofs of extremely small pores in the bodies, which, however, do not allow two bodies to occupy the same space,⁹⁷⁴ just like in Pauli's four hundred years later principle.

The reader provided the longest note of the Orbellis' claim on the dimension and position which are defining the body type (*una dimensione est simili-uno loco*). The reader commented and briefly reminded: */... Amata proxima Mobilis ... in Vacuo ego Stigmat /... Vacuo aria...*⁹⁷⁵

The Ljubljana reader briefly commented on the Orbellis' instrument described as the natural shining reflections in air (*Naturalia in aere Repercusso*).⁹⁷⁶ In the fifth chapter, Orbellis was thinking about the consequences of the divisibleness (*consecutio est aute*), and the apparently angry reader commented on the side

⁹⁶⁹ Orbellis, 1503 *Cursus librorum Philosophiae Naturalis*, 24r the right column.

⁹⁷⁰ Orbellis, 1503 *Cursus librorum Philosophiae Naturalis*, 24v left column.

⁹⁷¹ Orbellis, 1503 *Cursus librorum Philosophiae Naturalis*, 25r left column.

⁹⁷² Orbellis, 1503 *Cursus librorum Philosophiae Naturalis*, 25r the right column.

⁹⁷³ Orbellis, 1503 *Cursus librorum Philosophiae Naturalis*, 26r left column.

⁹⁷⁴ Orbellis, 1503 *Cursus librorum Philosophiae Naturalis*, 26r the right column.

⁹⁷⁵ Orbellis, 1503 *Cursus librorum Philosophiae Naturalis*, 26v left column.

⁹⁷⁶ Orbellis, 1503 *Cursus librorum Philosophiae Naturalis*, 27r left column.

margin.⁹⁷⁷ In the middle of the same chapter, Orbellis dealt with the indivisible and the types of quantities, and the reader supported him by comments inside his (or her) marginalia.⁹⁷⁸ The pointer with a fist was redrawn for Orbellis's interpretation of the time elapsed between motions⁹⁷⁹ and even on Orbellis's explanations of arguments that are not false at first glance.⁹⁸⁰ The Ljubljana reader wrote a note + accompanied with a *Number* in Orbellis' writings about the measurement of movement in the chapter about time.⁹⁸¹



Figure 6-183: The first page of natural History with physics with Marginals (Orbellis, 1503 Cursus librorum Philosophiae naturalis).

Unfortunately, part of Ljubljana native marginal thoughts on the side of the Orbellis' printed book was cut off when Škerpin ordered the book to be rebound in 1744.⁹⁸² Allegedly the same Ljubljana Franciscan reader wrote with his (or her) manuscript usual for 16th century while using the

⁹⁷⁷ Orbellis, 1503 Cursus librorum Philosophiae naturalis, 28v left column.

⁹⁷⁸ Orbellis, 1503 Cursus librorum Philosophiae naturalis, 29r the right column.

⁹⁷⁹ Orbellis, 1503 Cursus librorum Philosophiae naturalis, 30r Right column.

⁹⁸⁰ Orbellis, 1503 Cursus librorum Philosophiae naturalis, 30r the right column.

⁹⁸¹ Orbellis, 1503 Cursus librorum Philosophiae naturalis, 31r the right column.

⁹⁸² Orbellis, 1503 Cursus librorum Philosophiae naturalis, 26v, front of the cover.

browner ink; on the second occasion he or she used darker inks on the last page where he (she) wrote a table of contents with specially outlined chapters on the vacuum at the bottom of the left column at the comments on Aristotle's fourth Book of Physics.

Žiga Škerpin has greatly multiplied the Franciscan library treasures in Ljubljana. While he was in Trsat above the now Croatian Rijeka he has drawn a manuscript textbook of Aristotle's Physics with descriptions of the vacuum, which is now held in Ljubljana Franciscans' library.



Figure 6-184: The cutoff upper part of the discussing of the vacuum of Ljubljana reader in Ljubljana Franciscan copy of Orbellis (Orbellis, 1503 Cursus librorum Philosophiae Naturalis, 26r).



Figure 6-185: Double-cursors pointing the discussion of the vacuum in Ljubljana Franciscan copy of Orbellis (Orbellis, 1503 Cursus librorum Philosophiae Naturalis, 29r).

The students liked to use their professors' manuscripts in preparation for the exam in those old times. Of course, in the 18th century, the professors have not yet mailed their lectures or ideas as attachments to electronic messages to their students as they have not yet filled their young heads with the World Wide Web. Not even enough good copier machines were available. Hardly likely, but it is true: they liked to use those Professor's manuscripts as the only item available.

In 1734-1736 Pfeiffer's associate Vigiliј Dinarić lectured on philosophy on the Holy Mountain (Sveta Gora) above Gorizia. In 1739 he was a Lector of theology and casuistic at Trsat, during the years 1740-1742 he was a Lector of theology in Trsat, in the 1743 he Lectured on canon law in Trsat. In 1744 he was a magister on the Holy Mountain (Sveta Gora) above Gorizia and in the 1745 he was a lector of canon law in Trsat. As he was a general lecturer, the Senj Bishop took him for the Visitor of parishes of his diocese.⁹⁸³ On 27. 3. 1735,⁹⁸⁴ 20. 6. 1735⁹⁸⁵ and 16. 7. 1735⁹⁸⁶ in the Franciscan Monastery on the Holy Mountain (Sveta Gora) above Gorizia Dinarić finished his hefty unpaginated manuscript on Aristotelian physicists and related disciplines. He focused his 7th Question of 4th Aristotle's Book on Vacuum⁹⁸⁷ by quoting his religious co-brothers.⁹⁸⁸ He was interested in the resistance of the bodies, impenetrability⁹⁸⁹ and fear of the empty.⁹⁹⁰ In 8th question Dinarić tried to save the puzzle, the eternal controversial problem: is the absolute power of God sufficient to form a vacuum? With the quotations of Franciscan Doctor Scotus, Dinarić described water, air and fire even by Cartesian ideas.⁹⁹¹ In his 9th question Dinarić was looking for options for movement in the vacuum depending on (nonexistent) resistance, local movement⁹⁹² and the gravity-weight of movable dense particles of fire.⁹⁹³ Dinarić described the

speed of the local movement in the vacuum by St. Thomas and Scotus. Dinarić's velocity was a function of dilution, inertia, motion in resistive environment, and limited medium.⁹⁹⁴ If the movement in a vacuum is performed sequentially (Successive), then its speed is increasing, like the movement in the water. Dinarić liked the use of a vacuum in medicine but did not describe and draw barometers or pumps. According to Aristotelian Physical books, Dinarić wrote about the Generation and Corruption,⁹⁹⁵ about the heavens and the world,⁹⁹⁶ about Meteors⁹⁹⁷ and about the soul. Dinarić marked the individual planets with their ancient astrological signs along the edge of the sheet. He cited mostly the work of Ptolemy.⁹⁹⁸ As regards the movement in our solar system, Dinarić liked to refer to the Gospels and Book of Job.⁹⁹⁹ Dinarić did not name Copernicus or Galileo, as their works were still on the dangerous papal index.



Figure 6-186: Index of Orbellis' book formed under goose pen of Ljubljana reader with chapters on the vacuum at the bottom of the left column (Orbellis, 1503 *Cursus Librorum Philosophiae Naturalis*, last page).

⁹⁸³ Špelič, 2010, Obituaries (Nekrologij) of Province of St. Cross, 4528.

⁹⁸⁴ Dinarić, 1735, 4. The Book of Physics: 20r.

⁹⁸⁵ Dinarić, 1735, last page of manuscript dated 20. 6.1735 by signing Vigilio Dinarich.

⁹⁸⁶ Dinarić, 1735, De Generatione et Corruptione: 36v (12-12v).

⁹⁸⁷ Dinarić, 1735, 4. The Book of Physics: 13V.

⁹⁸⁸ Dinarić, 1735, 4. The Book of Physics: 14v.

⁹⁸⁹ Dinarić, 1735, 4. The Book of Physics: 14r.

⁹⁹⁰ Dinarić, 1735, 4. The Book of Physics: 15r.

⁹⁹¹ Dinarić, 1735, 4. The Book of Physics: 15v.

⁹⁹² Dinarić, 1735, 4. The Book of Physics: 17r.

⁹⁹³ Dinarić, 1735, 4. The Book of Physics: 17v.

⁹⁹⁴ Dinarić, 1735, 4. The Book of Physics: 18v.

⁹⁹⁵ Dinarić, 1735, De Generatione et corruptione: 1r-20v (10-1r-12-12v).

⁹⁹⁶ Dinarić, 1735, de Coelo et mundo: 1r-23r (11-1r-12-6v).

⁹⁹⁷ Dinarić, 1735, de coelo et mundo/de Metheoris: 37v-(12-6v-12-12r).

⁹⁹⁸ Dinarić, 1735, de Coelo et Mundo: 4r (11-4r).

⁹⁹⁹ Dinarić, 1735, de Coelo et Mundo: 7r (11-7r); Book of Job 9: 6.

Few months after Dinarić, on 9. 11. 1735 also on the Holy Mountain (Sveta Gora) the Lector of Ljubljana Franciscan philosophy, Pfeiffer, finished the second part of his philosophical manuscript. He discussed the fourth and fifth Aristotelian book of general Physics. Pfeiffer retained the classic Aristotle's sequence of interpretations in which the description of the vacuum was the basis of the second part of the fourth Aristotle's book on Space and vacuum. So, Pfeiffer, at his seventh question, wondered whether the vacuum opposed the (conception) of the space. Pfeiffer did the same thing in his seventh question as did his fellow Dinarić.¹⁰⁰⁰ Pfeiffer was discussing the possibilities of sharing the same place by several bodies in the same room and about the possibilities for the creation of a vacuum-based experiment with an clepsydra (water clock).¹⁰⁰¹ He relied on philosophy with physics of the Dominican professor of theology in Bordeaux Jacques-Casimir Guérinois.¹⁰⁰²



Figure 6-187: Title page of Škerpin's notes to the first Aristotle Book of Physics (Škerpin, 1714, 1).

¹⁰⁰⁰ *De vacuo ut opposito loco* (Pfeiffer, 1735, 22-11r-; Dinarić, 1735 Fourth Book of Physics: 13V (9-1v)).

¹⁰⁰¹ Pfeiffer, 1735, 22-11v.

¹⁰⁰² *Articulus Imus:... vacuum... Virtute causa creata sit possibile: ...Innumerables Experientia... Actu vacuum Guerinouis Ex 38: quae (Stio). Phy(s)ices pret. 2 quae. 5 de loco art. 4 SS 3 et 4* (Pfeiffer, ibidem, 22-12v, 6th Paragraph J.C. Guérinois, *Clypeus Philosophiae Thomisticae*, Venezia 1729, 4:293-294, 349-363 (quaestio 5 de loco, Artis. (=Aristoteles) 4, Paragraphs 3 and 4).



Figure 6-188: Seventh page of Škerpin's notes to the first Aristotle's Book of Physics (Škerpin, 1714, 1).

Guérinois was among the sharpest antagonists of Cartesians whom he treated with the excommunications. The Franciscans did not always love Dominicans (*Praedicatorum*), but the Ljubljana Franciscans used Guérinois book reprinted posthumously in 1729.¹⁰⁰³ That could prove a strong Anti-Cartesian stance among the Franciscans of those times. Guérinois's work had been acquired by Pfeiffer's eighteen-year-old master Škerpin soon after the printout. The pedantic Škerpin put his bookplate-label on it. The Ljubljana Franciscans had several other older Dominican works, including logic (1609) of the Italian Chrysostom Javellus (1472-1538), Polemical Metaphysics (1649) of Joan Martinez del Prado¹⁰⁰⁴ and Arnú's hefty philosophy. Pfeiffer has completely followed Guérinois's idea also about the possibility of God's creation of the vacuum and for local movement in it, while Dinarić limited himself to the references of the Franciscan summaries of Scotus' doctrine.¹⁰⁰⁵ Guérinois looked more deeply into Gassendi's atomism and experiments with (Boyle's)

¹⁰⁰³ Solatet Aetius T Ts: Fera innumerables experientia? fere quibus/zu entedis Nidebus glei actu vacuum, Quas ezoe gie Selpmao Mantanis an SS AD/Fuus Guerinouis ex 38: quae? Phyces pret 2 quae 5 de loco Art 4 SS 3 et 4 quret/vide Gvor (Pfeiffer, 1735, 22-12v, 6th. Paragraph, (Articulus 1mus: An detur vacuum behave Haabe Virtute causa creata sit possibile); Guérinois, 1729, 293-294, 349-363 (quaestio 5 de loco, Artic. 4, Paragraphs 3 and 4).

¹⁰⁰⁴ Prado. *Controversiae metaphysicales sacrae theologiae ministræ : tomus primus : primam et secundam partem earundem complectens*. Compluti (Alcalá) 35 km northeast of Madrid: Maria Fernandez viduam, 1649.

¹⁰⁰⁵ Pfeiffer, 1735, 23-1r, 23-5r; Guérinois, 1729, 4:366, 371; Dinarić, 1735 Fourth Book of Physics: 14v (9-2v).

pneumatic vacuum pump¹⁰⁰⁶ in his second and third volumes concentrated on physics.

In the next paragraph, Pfeiffer tried to explain vacuum with the ideas of Scotus. After the description of liquefaction, Pfeiffer's attributed the creation of the miraculous vacuum to God.¹⁰⁰⁷ He cited Descartes¹⁰⁰⁸ in the same explanation with Pfeiffer's religious co-brother Scotus¹⁰⁰⁹ and Aristotle.¹⁰¹⁰ Pfeiffer described the absolute power of God in his divine creation of the vacuum in the first query of his article number two, Dinarić was doing the same thing in his eighth query. They both rejected the misguided Descartes' description of Vacuum.¹⁰¹¹ Dinarić and Pfeiffer wrote much like the Croatian-Littoral captain in Bakar and Rijeka between 1716-1735 Adelmo Antonio count Petazzi of Novigrad in the responses to Descartes for the sake of God's creation of an otherwise infeasible philosophical vacuum.¹⁰¹² Adelmo Antonio count Petazzi's son Leopold Hanibal Josef Petazzi (1703-1772) became the bishop of Ljubljana in 1760, which helped the popularity of Adelmo Antonio count Petazzi's books that Dinarić and Pfeiffer read in the Ljubljana Franciscan Library.



Figure 6-189 : Petazzi's Sketch of the Movement (Petazzi, 1723, 280).

¹⁰⁰⁶ Guérinois, 1729, 4:357, 360-361.

¹⁰⁰⁷ Pfeiffer, 1735, 22-1v, 2r.

¹⁰⁰⁸ Pfeiffer, 1735, 23-1r.

¹⁰⁰⁹ Pfeiffer, 1735, 23-3v, 5v.

¹⁰¹⁰ Pfeiffer, 1735, 23-7v.

¹⁰¹¹ *De potentia dei absoluta fieri possit vacuum?* (Pfeiffer, 1735, 23-2r; Dinarić, 4th Book of Physics: 15v (9-3v)).

¹⁰¹² Petazzi, 1723, 81-89.

In the following, Pfeiffer was more dedicated to exploring the movement in the vacuum in three questions, while Dinarić resolved puzzle of the empty just with one very short question.¹⁰¹³ It seems that experimentation was not Pfeiffer's or Dinarić's better side.



Figure 6-190: Pfeiffer's title page of the year 1735 (FSNM).

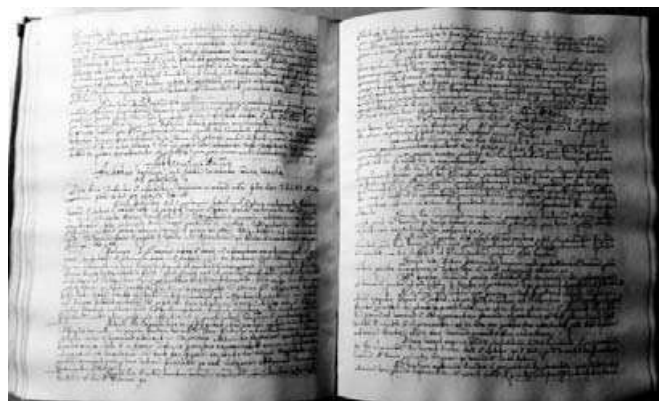

Figure 6-191: Pfeiffer on vacuum (Pfeiffer, 1735, 22-11v).

The upper Carniola (Gorenjska) Scholastic Scotus's follower Gotfrid Pfeiffer of Novo Mesto has taught the younger Franciscans for many years in Novo Mesto and Gorizia. He loved astronomy, but for the sake of Papal ban he could not be too enthusiastic about Copernican novelties. As a Franciscan theologian and representative of the Scholastic philosophy, he was of course a fan of Scotus' interpretation of the Aristotelian natural

¹⁰¹³ *Quaestio 2da: A Quo moveantur corpora ad replendum vacuum et qualis sit motus? Quaestio 3ia: De motu in Vacuo; Articulis 1mus: An possibilis sit motus in vacuo? Articulus 2dus: An motus in Vacuo esset successivus? (Pfeiffer, 1735, 23-3r, 5r, 6r); Quaestio Nona: An sit po(ssibi)lis Motu in Vacuo et quails sit? (Dinarić, 4. Book of Physics: 17r (9-5r)).*

history works. In 1735/36, the Jesuits placed Pfeiffer as a professor of physics at their advanced semi-university studies in Gorizia. Pfeiffer wrote six Latin texts, half of which are kept FSNM.¹⁰¹⁴ For his Gorizia philosophical lectures he wrote down his works on the Sveta Gora (Holy Mountain) monastery, which was one of the headquarters of Scotus' fans from the 17th century onwards. Pfeiffer wrote philosophical work *Cursus Philosophicus Praelectus iuxta mentem Doctoris Subtilis studiosae Juventuti* from which only the second part of his manuscript was preserved under the heading *Complectens Scientiam Natural, seu Physicam universam*. It focused on the philosophy of nature and general physics.¹⁰¹⁵ After his physics, Pfeiffer put his file *About the world, the sky and the elements (Incipiunt libri de mundo, coelo et elementis)*¹⁰¹⁶ on 1. 10. 1736. Pfeiffer described the structure and properties of the universe in the Leibniz' sense and mused-specified on eternity and supposedly the best of all worlds (*Meliorum et perfectionum*).¹⁰¹⁷ In chapter *About Heaven and celestial phenomena* Pfeiffer was discussing the number of heavens (*Orbs*) around the stars, the Milky Way, the sunspots and lunar "spots".¹⁰¹⁸ While questioning the movement of the sky Pfeiffer argued against Copernicus' bronze plate of the sun. Pfeiffer discussed Kepler's ellipses where the smaller earth circled the bigger Sun like the chickens circled their hen.¹⁰¹⁹ Pfeiffer described

Galileo's observation of the reflection of light on concave mirrors or the celestial machine as the opposition to older writers.¹⁰²⁰ Galileo deprived the moon of the light of its own. Galileo erroneously denied the role of the moon in tiding which Pfeiffer did not note. Pfeiffer discussed meteors which he rightfully put on the areas above moon¹⁰²¹ and explained several other astronomical features.¹⁰²²

Pfeiffer performed the highest functions in Franciscan order. In 1745 he was even Guardian (Custos) in Novo Mesto, and the next year he became the first Novo Mesto High school headmaster. He became the provincial of Croatian-Carniolan Franciscan Province (1748-1751) as a Ž. Škerpin's successor. On that highest position Pfeiffer was re-elected between 1757-1760 and 1766-1769.¹⁰²³

A decade after Dinarić and Pfeiffer, the other Ljubljana Franciscan lector had left his manuscript of physics unsigned in 1744/45. On 27. 8. 1745 on the session of their definitorium leaders the

neelis ad ventur in lapus neveris circa caelium si petius venes velut datus circa Ignes, Ignes fermente zonke zo aticed eod hete hiti veluti ignis, quo ete herren adicatus et fuaundatus, lebelit attia lerea luci in veteri, u totu curca terra. Hic quis Catu usd quasi infintae magis Herae Ienabilius aute e fut pud e minus moverei circa Mayus, qua Magius circa minus, Licet ti quis gallia neket afoere hucber/ud l' inghentes et fecintas verkes cyst illa veluere, S pedieue gellina Lebet Vertere, circa Eber Teretis (Pfeiffer, 1736, 31-10r, 31-10v (Quaestio 6ta, Articulus 1mus); Kepler was mentioned at the beginning of the fifth penultimate paragraph, Copernicus in the third).¹⁰²⁰ Tractatus Cum Galileas Fluit (flows) Nihil? Usuderet Redes Lucie Rubrum (Red) uticed latae civitates, (Schedules) elvetus verker neled ut test chider sucis anti oculos redetus ind Lucinis lebend meneras Cap ID ned Cambio qurnes/cedes Duc ad tunicas ire (jackets go) multo magis rhesfeti eternus hic 2 huis degendis si us adminchbite Calore machinas (machinery) zone?? /Eemplemus, Aellenus vetus jeller meld oculis nostris abnes lori, at u vadig insanis voce Fad Unese Ad Lucemsius per/lusteric hoc? Galileai actum Nih Letere Veteris; Ned a tantum nos Ptemplenen aulum, led age Nephis da (failed) Scegihara vetuli Oculi, Dei quo ous Ecolis-qua Lusterus universa per and Circudina Magis: L'Oreal nes il la Hbat seatet decit Galileaus, Lune jesemet Aub tuo medu Lucce siui curete perlunteriet lihebis, a uate liccesniula Eolli Othensere maliliter fico; Atri quasamas Alus Sid liherteend, Rhres Naas suit Pentetreus solidi (solid) Aquius/Tu putandet a caelus muteci (Mutifi), Quod vertas (vortex), in Vargedus aim Nar Hominus (Man) oder renad Mutari (Changes) Conventuales (Pfeiffer 1736, 31-11R, paragraphs 2 and 3).

¹⁰²¹ Pfeiffer, 1736, 31-12v (Disputatio 3ia, Quaestio 1ma).

¹⁰²² Murko, 1974, 34.

¹⁰²³ Bahčič, 2007, 232.

¹⁰¹⁴ Bregač, 2006, 209.

¹⁰¹⁵ FSLJ-29 F 24.

¹⁰¹⁶ Pfeiffer, 1736, from 31-1r to 32-5r.

¹⁰¹⁷ Pfeiffer, 1736, 31-2r.

¹⁰¹⁸ Pfeiffer, 1736, 31-7r (Quaestio 2da).

¹⁰¹⁹ 3rd Paragraph: Objectio prima Cur Copernicus deto? Duni ramus Aliqua Aula a sanitus lucerna in repela mdg in luco de it uniformites abs peditus luce genricere? Tehnit: io (= in that order) cute (= skin) sehe sid Veluti Ladeus Nihie die Lucendo, defecit (= failed) atied ods Huid nuevus abender Metius letedui Fici in medio, qua per natu misi Angulo. Ad hoc agulus quod ad meridian (feridien) neder Lentis opponitus recerti sund sermone (Ferisione) Signus squala a Copernicus du Lucerne (flashlight) Sonibus in Medis aula, eud atula debers Vetori Circa Lucernis ad Hames sund spised (filed), non celo (even) quod hoc abes expertus foerit: go ex eode agto Debebet deducere, quod nic Lerer da Solis lunine (Solar Lunar) indiget. Lebend circa jedes veteri (ventus, Wind). Diaser nec Comparatis Bona in Aglo; Ad sed heres fugura (figurine) Sphaerica, Nueque ut deto illuminari, ante quis meduntas, ende a debet spareraai oni aula et pakis hoc ulitio 10 Taus habet variendehe orbis (orbit) Cubiculatorum luges et Habter: Hiunt ergo et tabu relatum stirnis seccesuit a detet Inkus fokus Merti circa Lucerne Apetius Lucerna Tehet de Cubiculo in Cubiculi sbelia it lia ut Leret illuminatus, a tebet verti circa Solem, naretius Sol circa jahed. Dicus cum Keplero annendus a Deus Scipha eus qua ad ratio arti e

Franciscans selected the lecturers for their new jobs; then they arranged also the lecturers of philosophy with physics. So, they had the lecturer of Philosophy Paulian Korač in Sveta Gora for the year 1744. In Novo mesto Hieronim Markilič and Bonaventura Vietrih lectured. In next year 1745/46 on the Holy Mountain (Sveta Gora) Korač and Hugo Vodnik lectured. In Novo mesto Krizostom Perkopac and Šuštaršič taught, at Klanjac in Croatia Bonavio Dietrih and Hieronim Markilič lectured. On the General Studies in Ljubljana lectured Vincent Marjašič and Ambrož Bedenčič (OFM died on 4. 4. 1750 in Kostanjevica) who served as a general Lector and vicar in Jaska, and at Trsat.¹⁰²⁴ Zaharia Matko taught at Trsat and the magister Avrelij Zevko (Čeuko, Zheuko, Frans Aurelium Zhenkho, D. 1746 in Ljubljana) taught the Franciscan youth in general studies of Ljubljana.

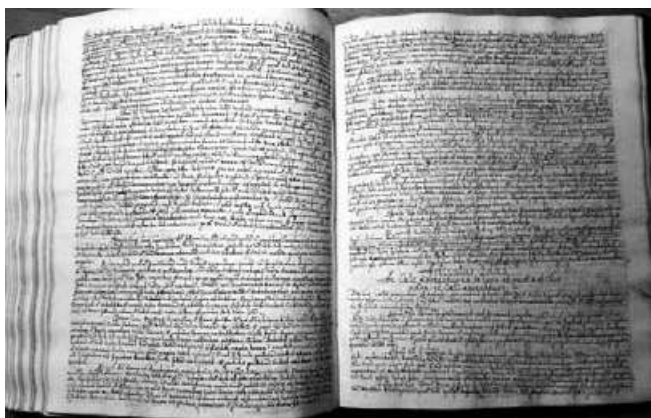

Figure 6-192: Pfeiffer's opinion on the Copernicans and Galileo's work which was put on the Papal Index of prohibited Books (Pfeiffer, 1736, 31-11r, paragraphs 2 and 3; Benedict XIV, 1758, 118).

The comparison with manuscripts from the era 1769-1774 shows that Markilič did not produce the work of 1744/45. The similar comparisons with Zevko's bookplate in Duhan's book in FSLJ shows just some similarities in writing the letter A, and much less in writing the letter P. Zevko used Duhan's book of FSLJ while he taught philosophy in Ljubljana Franciscan studies in 1727. The most likely authors of the manuscript of 1744/45 were Vincent Marjašič or Ambrož Bedenčič. Marjašič used many books from Ljubljana Franciscan library, but he put his printed bookplate in them like Škerpin, therefore Marjašič's handwriting is not recognizable and provable as far.

¹⁰²⁴ Dr. Jože Škofjanec's 2010, List of rectors and magisters.



Figure 6-193: The title page of the physics of Ljubljana Franciscan professor who taught in the year 1745.

The author of manuscript of 1744/45 paginated only the couple of his initial sheets and the beginnings of his paragraphs. He provided no index. At the end he specified the date on 3. 9. 1745. In between, the older dates of the same year figured at the ends of individual books. He dedicated a brief introduction written on less than one page focused on the working with scientific devices. Firstly, of course, he wrote about the ancient origin of the term physics,¹⁰²⁵ as usual in those times. He followed the Aristotelian books including his third book of Physics.¹⁰²⁶ The 4th Book of Physics was the most interesting vacuum piece,¹⁰²⁷ as usual in Aristotelian frames. *Disputatio Secunda Or Quaestio Secunda De Vacuo* lacked the pagination except on the beginning of paragraph.¹⁰²⁸ The third question asked about the vacuum and movement in it. Can

¹⁰²⁵ Anonymous, 1745, 2r.

¹⁰²⁶ Anonymous, 1745, 171^v

¹⁰²⁷ Anonymous, 1745, 178^f

¹⁰²⁸ Anonymous, 1745, 189^v.

the bodies move in a vacuum?¹⁰²⁹ The vacuum section ended 4th book.

The fifth book was dedicated to the infinity.¹⁰³⁰ Of course, the author relied on Scotus.¹⁰³¹ On the side he put marginal corresponded additions and insertions marked with plus signs.¹⁰³² He had the infinity for the category of God.¹⁰³³ On 21. 5. 1745 the comments in Aristotelian fifth book were completed with citations and references of other writers,¹⁰³⁴ which could not yet include a young Bošković.



Figure 6-194: Sketches of Ljubljana Franciscan professor from the year 1745 (Anonymous, 1745, 204r).

The sixth book began by addressing the continuity¹⁰³⁵ and citations of the Angelic doctor Scotus. The only three recognizable sketches were afforded on the second page of the second question of the sixth Book of Physics under the title *Ars Continuum ex Solis Indivisilibus Componantur?* The author put them at the bottom of the page, describing Zeno's paradox in the movement of Eagle and turtle. With points, tangents and instantaneous movements he proved the paradox to be absurd.¹⁰³⁶ The chapter has been updated with the hefty marginals added somewhat later, not during the teachings of the same guy, but by some other later reader, who could have been the next Franciscan lecturer of philosophy.¹⁰³⁷

The author then dealt with the other Aristotelian books of physics very briefly, among them with

seventh book of physics.¹⁰³⁸ The remaining Aristotle's ideas about the natural sciences has only been summarized as a learning of *Tractatus sinopticus de omnes libros de coelo, Mundo et Meteoris*¹⁰³⁹ by reading some sporadic puzzles.¹⁰⁴⁰ The writer had more to say about Aristotle's book *De Anima*.¹⁰⁴¹ He finally embarked on metaphysics.¹⁰⁴² His text was further complemented by the Ljubljana Franciscan professor(s) who taught after the year 1745, as is evident from a few Marginals written after a long time on the side of the original text completed at the beginning of the school year in September 1745. Unfortunately, the writers did not add any topics index, so that remarkable peripatetic manuscript written with the letters of the condensed font is somewhat nontransparent.

In the middle of 18th century the Franciscans of Ljubljana produced another similar bulky extensive manuscript. The last pages of it are sadly missing, therefore, the name of the writer is unknown, and the year of writing could be just approximately put in 1750-s. The anonymous writer still declared that the nature is afraid of the vacuum. The writer claimed he could explain the burning of a candle in the air and in a vacuum. The Almighty God can create an impossible vacuum, which is a miracle. God's finger thus allows local movement in the empty including the local movement of omnipresent angels.¹⁰⁴³ He insisted on four elements: fire, air, water, and earth.¹⁰⁴⁴ He did not mention then already a century old vacuum experiments because he preferred good rhetorically sound logic and not eventually otherwise shaped reality. In the only partially preserved astronomical conclusion of his notebook, he advocated the rotation of the sky within 24 hours without specifically pointing out the opposite Copernicus's opinion.¹⁰⁴⁵ Later the author added some vertical marginal notes. He quoted just some of his models like St. Augustine, St. Thomas Aquinas, Scotus, or

¹⁰²⁹ Anonymous, 1745, 190v unpaginated.

¹⁰³⁰ Anonymous, 1745, 190r.

¹⁰³¹ Anonymous, 1745, 191.

¹⁰³² Anonymous, 1745, 194r.

¹⁰³³ Anonymous, 1745, 197r.

¹⁰³⁴ Anonymous, 1745, 201r.

¹⁰³⁵ Anonymous, 1745, 202r.

¹⁰³⁶ Anonymous, 1745, 204r; Aristotle, 1987, 172.

¹⁰³⁷ Anonymous, 1745, 204v.

¹⁰³⁸ Anonymous, 1745, 211r.

¹⁰³⁹ Anonymous, 1745, 220r.

¹⁰⁴⁰ Anonymous, 1745, 223v.

¹⁰⁴¹ Anonymous, 1745, 225r.

¹⁰⁴² Anonymous, 1745, 267.

¹⁰⁴³ Anonymous, 175?, Incipit Philosophia naturalis, seu Physica FSLJ-16 g 115/Liber Quartus Physicorum, 35r, 36r, 38r, 41v, 44v.

¹⁰⁴⁴ Anonymous, 175?, Incipit Philosophia naturalis, seu Physica / Generatione et corruptione, 33r.

¹⁰⁴⁵ Anonymous, 175?, Incipit Philosophia naturalis, seu Physica / Mundo et coelo, 21r, 22r.

Aristotle. Among his contemporaries the author moreover noted Fonseca, probably Pedro de Fonseca as one of the first followers of St. Ignatius or more likely the Franciscan bishop in Évora in Portugal José Maria Ribeiro Fonseca.¹⁰⁴⁶ Imaginary spaces have been described by the data of Bonaventura Baronius.¹⁰⁴⁷

In the manuscript bind to *Dialectics* written in the same year the now anonymous Franciscan writer narrated about the general physics as a science in 1768. In *dei nomine tractatus ad universam Physicam sey Scientiam Naturale* the Franciscan author wrote 192 pages with their unpaginated subject matter index added at the end.¹⁰⁴⁸

First, the writer explained some particularly puzzling effects of the sparks of fire, fluids like water or air, the extinguishing of candle in vacuum, and lighting. He described the systems of atomists like Democritus, Leucippus, Gassendi,¹⁰⁴⁹ or Descartes as the wrong systems of ideas.¹⁰⁵⁰ The chemists connected with the alchemists were nicknamed spagyrically in the habits of those days. They reasoned on the basis of individual elements used in their transformation processes.¹⁰⁵¹ The writer later added on his marginal side the notes on the observations of “Clarissimi” English anatomist the secretary of RS Nehemiah Grew (1641-1712),¹⁰⁵² and finally highlighted exploration of Grew’s senior collaborator Boyle focused on salts and mercury.¹⁰⁵³ The writer explained the elementary systems of Empedocles from Akragas (Ἀκράγας, Agrigento) in Sicily, Pythagoras or his fans and his pupils based on atoms as the elements.¹⁰⁵⁴ The writer was interested in Achilles’ puzzles and in the theory of four elements¹⁰⁵⁵ according to the bishop of Cyrus named Theodoret

(c. 393 – c. 457).¹⁰⁵⁶ The writer also discussed the other philosophical systems of Anaxagoras as narrated by Aristotle. He explained ideas of Zeno and Plato, with Descartes included. Among the new scholars there was Isaac Newton with his impenetrable massive atoms of solids,¹⁰⁵⁷ Leibnitz’s seemingly misguided psychology with Monades and active forces. The “Clarissimus” Christian Wolff as Leibniz’ fan was noted separately with his material atoms of masses discussed inside the paragraphs about physics which was discussed apart from other paragraphs devoted to arithmetic. The writer explained Wolff and Leibnitz’s ideas on the whole page, while Newton deserved only much shorter paragraph just ten lines long; that neglect of Newtonian physics was about to change in Habsburgian approach of those times after the school authorities preferred Bošković’s combination of Newton and Leibnitz’s approaches over the older Franciscan Duns Scotus and similar peripatetic ideas. With that in mind, the author was certainly not yet a Newtonian but a fan of the neo-Cartesian doctrine of Noël (Natalis) Regnault which gained the popularity among the Habsburg Jesuits of those times although Regnault preferred Descartes against Newton mostly as a French nationalist. The writer stated so many puzzles which were resolved by the Jesuit father Regnault in second part (Tom 2) of his *Physics* regarding ethers and flame according to the Egyptian and Herodotus’s doctrine.¹⁰⁵⁸ Finally, the author explained the Peripatetic system on several pages without quoting any writers.¹⁰⁵⁹ Of course, the Ljubljana Franciscans observants kept Regnault’s *Physics* at last in three Latin language editions of 1736, 1747 and 1755, all of them published by the Jesuits Josef Staininger and Dollenz in offices of the local printers the Tyrolean Joann Jacobus Jahn (Jan) in Steyr and Widmanstad in Graz. The barefoot Augustinian pater Anastasius and Ljubljana Jesuits in 1754 and Erberg got their Latin language Jesuitical Carolus Dollenz’s translation of Regnault which later went to Ljubljana NUK and National Museum libraries, while the Piran scholars preferred the earlier Italian Venetian translations of 1736. Finally, the Franciscan writer has delivered the basics of the Peripatetic system without noting his sources. According to the metaphysical interpretation of

¹⁰⁴⁶ dice cum Fonseca (Anonymous, 175?, Incipit *Philosophia naturalis, seu Physica / Liber Sextus Physicorum de Continuo*, 12r).

¹⁰⁴⁷ Anonymous, 175?, Incipit *Philosophia naturalis, seu Physica / Generatione et corruptione*, 12v.

¹⁰⁴⁸ Anonymous manuscript of 1768 (FSLJ-4 b 5) with incorrect other reference code FSLJ-29 f 29 unlike the manuscript of 1770-1771 with reference code FSLJ-(2555) 29 f 34

¹⁰⁴⁹ Anonymous, 1768, 14.

¹⁰⁵⁰ Anonymous, 1768, 16.

¹⁰⁵¹ Anonymous, 1768, 18.

¹⁰⁵² Anonymous, 1768, 21.

¹⁰⁵³ Anonymous, 1768, 2.

¹⁰⁵⁴ Anonymous, 1768, 22.

¹⁰⁵⁵ Anonymous, 1768, 23.

¹⁰⁵⁶ Anonymous, 1768, 24.

¹⁰⁵⁷ Anonymous, 1768, 25.

¹⁰⁵⁸ Anonymous, 1768, 26.

¹⁰⁵⁹ Anonymous, 1768, 27.

matter and form, he embarked on a system of contemporaries without quoted names¹⁰⁶⁰ and then he discussed a mechanical system¹⁰⁶¹ among which he involved peripatetic and especially the Cartesian Nicolas Malebranche.¹⁰⁶² Along with the natural positions he first briefly explained his vacuum in the Sectio 3¹⁰⁶³ where the author cited mostly Gassendi's assumptions.¹⁰⁶⁴ In the Sectio 7 with its paragraph 2 the Franciscan writer provided a treatment of philosophical vacuum which that author discussed more profoundly in three aspects formed as the objections against his more peripatetic old fashioned unnamed opponents:

1. Vacuum is again noted in cases of amphorae containing the detectably moving fluids, as a recurrence of motions;
2. Vacuum in space, its locations in hyperbolas, fullness of substance of vacuum;
3. The double definition of vacuums in liquid water and in gaseous air was explained while it was extended to a large scale according to Gassendi.¹⁰⁶⁵

Descartes and a modern Newton described the philosophical vacuum. The accumulated vacuum under the principles of Newton was a void whose existence was supposedly proved according to experiments on separation or discontinuity. The Franciscan author provided his first opposition: Torricelli's experiment rises the level of mercury for 28 fingers (inches) in the tube, prevents the access of air into the tube, while vacuum is supposedly formed and maintained in intermediate space of the recipients or vacuum pump *Antlia Pneumatica*. The experiments were designed in a vacuum above mercury or in a pneumatic machine named *Antlia*. In his first objection the Franciscan author described the Torricellian experiment and the lifting of mercury for 28 fingers in the tube while vacuum maintained the intermediate volume. The rest of mercury prevents the access of air. Similarly, the recipient worked in the Pneumatical pump (*Antlia Pneumatica*). The light affects the pores of the glass, as also heat and cold could. The Franciscan author also cared about the behavior of fluids in the vacuum.

¹⁰⁶⁰ Anonymous, 1768, 32.

¹⁰⁶¹ Anonymous, 1768, 41.

¹⁰⁶² Anonymous, 1768, 42.

¹⁰⁶³ Anonymous, 1768, 78.

¹⁰⁶⁴ Anonymous, 1768, 79.

¹⁰⁶⁵ Anonymous, 1768, 2:91.

In the second objection the Franciscan author was experimenting with cold and hot water. He filled his container with oil and ignited a small flame, while the vacuum penetrated in the space previously occupied by oil.¹⁰⁶⁶ If the Franciscan author prevented the access of air to the his source of light, it turned off while the air was forced up and replaced with a vacuum. The Franciscan author worked with a hammer on a very fragile substance. The drops which were slowed down would take place during motions in the substance, so as it happened with the movement of the planets in the vacuum, which the vacuum permits without friction. The same goes for the movement of comets through the finest fluid, as well as also the motion of light of stars and the sun. The warmth of the cosmos is exceptional for the sake of subtle ether. The planets are moving and the sun shines. The vacuum builds up and accumulates because the fullness of a world would impede and hamper the motions. The rarefied vacuum again paradoxically refills the liquid space of the universe. A complete full environment would hinder movement; so, the dilemma keeps the paradoxical empty space constantly flowing. Experiments with vacuum pump have rebutted the presumption of fear of emptiness. The dilution fills (in fact, empties) the space. Experiments with (Boyle's) *Antlia* refuted the assumption of fear of vacuum. The Ljubljana writer has precisely written the size of individual parts of the pump, but failed to mention Boyle by his name, probably because the Protestant Boyle was not a best reference for the young Franciscan students. Tube put at fountain (*Syphunculus*) was 60 feet long, i.e. almost 20 m¹⁰⁶⁷ which corresponded to the pressure of the two atmospheres.

In his third objection, the Ljubljana Franciscan writer was interested in the thickness of the air layer (atmosphere). In this he outlined the prevalence of the vacuum in nature and supported the atomists in their dispute against the Peripatetics; he also praised the advocates of Ptolemy who were more favorable to vacuum. The shaking (vibrations) of atoms is disseminated by vacuum while the vacuum separates atoms from each other.¹⁰⁶⁸ The Franciscan author explored the movement of flies and the impulses by Newton's theory based on the experiments with a wooden

¹⁰⁶⁶ Anonymous, 1768, 2:92.

¹⁰⁶⁷ Anonymous, 1768, 2:94.

¹⁰⁶⁸ Anonymously, 1768, 2:94.

ball and leaden heavy hard balls. Both have the same resistance, which vanishes in the vacuum where the balls behave regardless of their density.¹⁰⁶⁹ Despite their unequal weight, it is expected by the Galileo's imagined experiments that they should have the same speed during their free fall in a vacuum. The Franciscan author was interested in penetrating of the vacuum into a fluid. Next, the Franciscan author discussed the cohesion of the solidified matter¹⁰⁷⁰ in the famous experiments allegedly involving the attraction between atom until J. Stefan proved that the other kinds of forces must be involved in that type of cohesion.

The Franciscan author then added appendix to discuss the allowing specifics of the local successive movement in the vacuum, during this successive, not completely instantaneous motion.¹⁰⁷¹ Then the Franciscan author embarked with definitions of motion in his 4th section.

The Franciscan author was interested in flexible movements,¹⁰⁷² reflection and refraction,¹⁰⁷³ as well as he wished to learn about the laws which governed the motions.¹⁰⁷⁴ He wrote about the fire,¹⁰⁷⁵ earth,¹⁰⁷⁶ and in his last dissertation he focused on special qualities and mostly on warmth¹⁰⁷⁷ and cold.¹⁰⁷⁸ He avoided mentioning any electricity, magnetism or optics which belonged to the other branches of particularly developed experimental physics. He wrote about fluids,¹⁰⁷⁹ specially about the motion of solids and fluids.¹⁰⁸⁰ He illustrated the movements caused by gravity with the examples used by machinery.¹⁰⁸¹ He was interested in the pressure of fluids,¹⁰⁸² the hydrostatic principles¹⁰⁸³ and in the last section he discussed the weight of air.¹⁰⁸⁴ His mass of air was

described with the experimental designs of *Antlia Pneumatica* which the Franciscan author noted as Guericke's invention allegedly pictured on fig 1 of table 7, which were, sadly, not attached anymore in his preserved manuscript in FSLJ. He then described a whole row of range of nine experiments, including those designed to protect the plant from putrefaction. For the pneumatically designed machines the Franciscan author used the names Torelli and Jaglini; the first of those may be abbreviated for Torricelli, while the other might be a misspelled family name of Viviani, although many architects and other designers named Torelli also worked in those times. Such funny mistakes with the names cited were not unusual in manuscripts written by the lecturers who were not professional naturalists but happened to be hired as professors of physics within philosophy just for a while before they were offered the more respectful jobs of theologians or administrators. There was no per-reviewing to correct those unpublished manuscripts.



Figure 6-195: The appendix about movement in a vacuum in Ljubljana Franciscan professor from the years 1768 and 1771.¹⁰⁸⁵

Next, nine experiments were carried out in a row, including the protection of plants against rotting. The Franciscan author explained a Torricelli's tube filled with mercury,¹⁰⁸⁶ even in suspension of vacuum in vacuum of Huygens' invention. The Franciscan author was interested in observing and

¹⁰⁶⁹ Anonymous, 1768, 2: 91 (Sectio 7article 2), 92,

(syphunculus, Sipunculus = worm), 94, 95.

¹⁰⁷⁰ Anonymous, 1768, 2:95.

¹⁰⁷¹ Anonymous, 1768, 2:98-100.

¹⁰⁷² Anonymous, 1768, 118.

¹⁰⁷³ Anonymous, 1768, 122.

¹⁰⁷⁴ Anonymous, 1768, 123.

¹⁰⁷⁵ Anonymous, 1768, 141.

¹⁰⁷⁶ Anonymous, 1768, 164.

¹⁰⁷⁷ Anonymous, 1768, 163.

¹⁰⁷⁸ Anonymous, 1768, 163. 166.

¹⁰⁷⁹ Anonymous, 1768, 168.

¹⁰⁸⁰ Anonymous, 1768, 171.

¹⁰⁸¹ Anonymous, 1768, 178.

¹⁰⁸² Anonymous, 1768, 182.

¹⁰⁸³ Anonymous, 1768, 183.

¹⁰⁸⁴ Anonymous, 1768, 185.

¹⁰⁸⁵ Anonymous, 1768, 98.

¹⁰⁸⁶ Anonymous, 1768, 186.

measuring the elevations of higher positions on the hills carried out by Pascal's brother-in-law at Fig. 3 Tab 7. The pipe used had a height of 32 feet.

The design of *Antlia pneumatica* was described in figure 2 of table 8 and the Franciscan author outlined the weight of the air also in his notes on the siphon at the second question on Fig. 4 tab 8. On Fig 3. tab 9 the Franciscan author described Musschenbroek's accomplishment. He knew much about the adhesion of water during the Hugenius' test, where he used the misspelled Latinized Huygens' name. The pipes could also use wine instead of mercury. There was a subtle ether in pores of glass near mercury.¹⁰⁸⁷ With a reference to Musschenbroek the Franciscan author compared the weight of air, steam and water as did other Franciscan writers of those days but that same very agile Franciscan also provided the numbers measured. In the third question of the rising of Mercury in the pipes the Franciscan author also acknowledged the changeable force of gravity while we approach the Equator.¹⁰⁸⁸ He again mentioned the suspension of Mercury,¹⁰⁸⁹ certainly the one from Idrija. He discussed the relationship between Earth and ether and the color of the air at higher altitudes. The Franciscan author was interested in measuring heat and cold. He merely listed the barometer, baroscopium, manoscopium, pressure gauge, termoscope as the discontinued variant of thermometer, hygroscope as the discontinued variant of hygrometer. Then the Franciscan author provided a broader description of the listed devices, beginning with the barometer full of mercury on Fig. 5 of Table 9.¹⁰⁹⁰ He then embarked on a baroscope to measure the changes in the weight of air, manoscope to measure air density and thermometer also stuffed with the wine according to the Musschenbroek's instructions, or in Daniel Fahrenheit's design with the (Idrija) mercury. The Franciscan author used also a Florentine thermometer and described its scale. Later, the Franciscan author added with a lighter ink notes about his ability to determine the cold. He described the Hygroscope with iron (ores) for the measures of changes of moisture of the air at figure 9 of table 9.¹⁰⁹¹ The Franciscan author used a slightly lighter ink in his last paragraph before the prayer to St. Francis and the saints. He devoted

it to the summary of all these experiments. He relied on the second section of his manuscripts for the options of the water.¹⁰⁹² The Franciscan author described the machines evolving from the simplest to more complex whose peaks were his vacuum measuring devices with barometers, thermometers and pumps. He didn't mention the steam engines.

The Franciscan author's book of 1768 has a slightly larger format compared to the books of the same writer issued in the year 1770-1771. He then also used the similar binding with leather covering spines and edges of a book, but he designed a more colored marmorated cover in 1768.

During the years from 1772 to 1774, the other Franciscan wrote on general physics for the instruction of his students. He described the pores with a vacuum and wondered if the vacuum was maintained, as a self-sustaining vacuum. He opposed the then modern enthusiasm for the ideas of Gassendi with Epicurus included and described Torricelli's mercury tube. The achievements of vacuum pumps experiments were most disturbing. Among all the substance in question the author was the most affected by the achievements of vacuum pumps. Upon re-reading his own manuscript, he did not add only side notes to his own handwriting, but he had to stick an additional sheet, and he soon ran out of space for the sake of many novelties intended to inform the reader. He described the views of the Atomists like Leucippus, Democritus, Epicurus and their contemporary heirs, a subtle substance and a fluid molecule. He was especially delighted and impressed by the *Antlia pneumatica* vacuum pump with which Musschenbroek tested the properties of mercury, even though the Franciscan writer still conditioned the existence of a vacuum with the operational intervention of God. He explained the events in Torricelli's tube and vacuum pump with Newton's and Lucretius's atoms. He additionally described interesting experiments with water, wine or burning of a candle. *Antilia pneumatics* created a vacuum and that was possible despite the quotations of Book of Job from the Old Testament. Job's tirade Book of Job 3: 5: *Let it never have been created, Let it sink back into the void, Let chaos overpower it.* And again, in Book of Job 6: 18: *Going up into the void and perish.* And, finally in Book of Job 26: 7: *He stretches out the north over the void and hangs the earth on nothing... God puts solid good in the void*

¹⁰⁸⁷ Anonymous, 1768, 188.

¹⁰⁸⁸ Anonymous, 1768, 189.

¹⁰⁸⁹ Anonymous, 1768, 190.

¹⁰⁹⁰ Anonymous, 1768, 190.

¹⁰⁹¹ Anonymous, 1768, 191.

¹⁰⁹² Anonymous, 1768, 192.

where Satan dwelt. There are some voids noted even in the Genesis 1: 2: *The earth was formless and void, and darkness was over the surface of the deep, and the Spirit of God was moving over the surface of the waters: formless and void* (tohu-vavohu). The denial of void in the Bible was far from explicit, even less convincing than the seemingly Anti-Copernican stance in Joshua 10: 13: *And the sun stood still, and the moon stopped, until the nation took vengeance on their enemies. Is this not written in the Book of Jasher (Jasher, הַיָּשָׁר)? The sun stopped in the midst of heaven and did not hurry to set for about a whole day.* Therefore, it was not hard for the Franciscan writer to replace the fear of emptiness with the weight of the air. The vacuum is possibly supernatural, although it is rejected by the Cartesians; it could have been aligned and reconciled with the updated science of Franciscan Duns Scotus.¹⁰⁹³

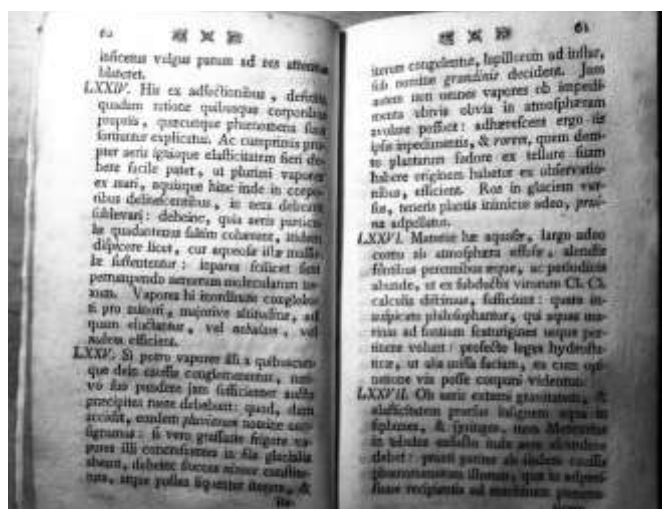

Figure 6-196: Questions about vacuum pumps at the Innsbruck exam at Kapferer's class, stored at Ljubljana Franciscans' library (Kapferer, 1778, 60-61, with the permission of Prof. Dr. Miran Špelič, OFM).

In 1774-1775, the same writer with the identical handwriting compiled Special Physics. He described the Copernican system, sketched Kepler's ellipses, noted Ptolemy and Tycho. He quoted Fortunatus Brixianus' descriptions of astrology before dealing with meteorological phenomena. He maintained Beccaria's opinion of the natural light of fluids, and he was especially interested in the achievements of Musschenbroek; he used the calculations of the speed of light on its

¹⁰⁹³ Anonymous, 1772?, 44r (4: 9r), 44v, 45r-46r, 47r, 47v, 48r, 48v.

way from the sun to earth and he reported about Bourger's research. Finally, the author of 1774-1775 manuscript described electricity; like Jaszlinsky or Zinsmeister, he described conductors (symper-electrics) and experiments with electric sparks without mentioning Franklin. Referring to the tourmaline, the author of 1774-1775 manuscript noted Musschenbroek; he also described the underground and magnets.¹⁰⁹⁴

The Ljubljana Franciscan Higher education of those days have been in many ways modelled by their co-brother experts from Tyrol. The teachings of those days in Tyrol were beautifully illustrated with 75 physical exam theses about the bodies and with 54 mathematical theses. The students had to defend their abilities in the class of the Franciscan Professor Simon Lypnica Kapferer in the monastery of Hall in Tyrol east of Innsbruck. Lypnica Kapferer's designs of vacuums in barometers and pumps were described in a modern way.¹⁰⁹⁵ They scorned alchemy a little bit and accepted Newtonian Optics.¹⁰⁹⁶

6.5.6 Bavarian Vacuum for Ljubljana Franciscans: Bavarians Taught Vacuum Technology to Carniolan Literati

6.5.6.1 Ljubljana Franciscan Manuscripts about the Mathematical Sciences: Hieber from Cham

Zinsmeister and other Ljubljana Franciscans widely used the manuscript textbook exam theses of Zinsmeister's older Bavarian compatriot, the lecturer of philosophy Castul Hieber (* 1761 München; OFMobs 1780; † 18. 8. 1810 Ingolstadt) from the monastery Cham (*Cambiensi*) in East Bavaria 50 km northeast of Regensburg. Hieber was probably of Slovenian origin because the nobles with his last name owned the manors in Vipava valley. The Franciscan Hieber defended his polemic and dogmatic theological PhD exam on historical aspects of sacraments and dogmas in

¹⁰⁹⁴ Anonymous, 1774-1775, 1 / 22v, 2 / 1r (November 24, 1774), 4 / 1r, 8r (in margin noted Beccaria's publication in Acts of Bologna), 8v, 9r, 10r, 10v, 14r, 16v.

¹⁰⁹⁵ Lypnica Kapferer, 1778, p. 61-62 (thesis 76).

¹⁰⁹⁶ Lypnica Kapferer, 1778, p. 58 (thesis 72), p. 64-65 (Thesis 85).

Munich in the class of Rupert Pröbl (Proessl) on 4. 8. 1785 and on 20. 6. 1786. Hieber or his students accomplished two manuscripts based on Hieber's exam theses which Zinsmeister himself or one of his Bavarian colleagues brought to Ljubljana. Hieber signed one of the manuscripts on August 11, 1796 and filled its pages with discussions on philosophy, mathematics, and some contemporary Herschel's astronomy about the Uranus' and Saturnus' satellites and comets for the conclusion.



Figure 6-199: Hieber's sketch of balance in fluids as the introduction to the description of vacuum pumps (Hieber, 1797, 66).

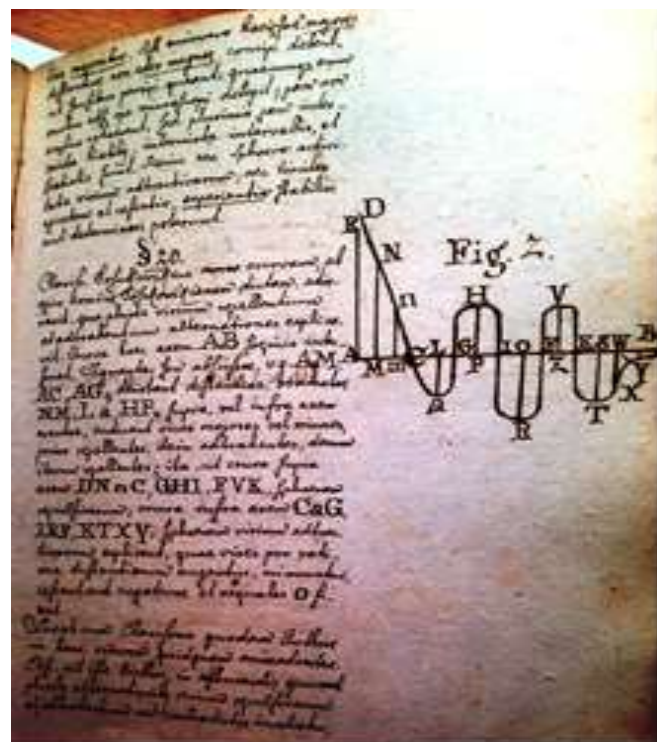

Figure 6-197: Zinsmeister's figure of the Bošković's force (Zinsmeister, *ibid.*, 2: p. 23 (The courtesy of Dr. Prof. Miran Špelič, OFM)).



Figure 6-200: Hieber's description of vacuum pumps and the barometer (Hieber, 1797, 66).



Figure 6-198: Hieber's sketch of his experiments with fluids (Hieber, *ibid.* 1797, p. 66 (The courtesy of Dr. Prof. Miran Špelič, OFM)).

Hieber later also noted Fontenelle's ideas of inhabited cosmos.¹⁰⁹⁷

Soon after the first manuscript, in the other manuscript kept in Ljubljana Franciscan library Hieber discussed physics and added some unfinished geometrical definitions to the very end. In his discussion of the philosophy of bodies called theoretical (general) physics he described the inertial force in the terms of Newton and Bošković.

¹⁰⁹⁷ C. Hieber, *Theses selectiores ex philosophia*. Pedemontium, 1797, p. 26 (thesis 60); C. Hieber, *Theses selectiores ex philosophia*. Pedemontium, 1799, p. 13, 15 (thesis XL, XLVIII).

He filled his Universe with vacuum and accomplished some experiments on porosity of matter. In so-called “particular” part of physics, which was mostly the experimental physics, Hieber described the heat as the effect of small particles’ translation according to D. Bernoulli’s ideas as one of prevailing opinions of Hieber’s times. In the question of light’s substance, Hieber was unable to decide between the Newton’s particles and Euler’s undulation theory although he noted the elastic fluid emanation needed for the propagation of light. Hieber calculated the height of atmosphere and the weight of air. He contradicted the Cartesian anti-vacuum theory with modern description of air pumps and barometers which supposedly produced the disputed vacuum.¹⁰⁹⁸ Hieber supported Franklin’s theory of electricity, conductors (symper-electrics), and various aspects of healings with electrifications.¹⁰⁹⁹

6.5.6.2 Zinsmeister

Kastul Hieber (Castulus) explicitly spoke against Bošković’s infinite divisibility of the substance without writing Bošković’s name. Hiebel stated: *Divisio infinita veritas est in mathesi, error in physica*. It was the most disputed among Bošković’s ideas and many Bošković’s followers preferred to ignore it. Hiebel was apparently one of those. Nonetheless, Hiebel influenced the Carniolan Franciscan Novo Mesto professor of mathematics and Greek language Teofil Zinsmeister (baptized Franc, * 2. 11. 1777 Bavaria; OFM 10. 10. 1796; † 12. 11. 1817 Novo Mesto) who enthusiastically painted down a famous Bošković’s curve anyway under Hieber’s influence in his manuscript textbook.¹¹⁰⁰

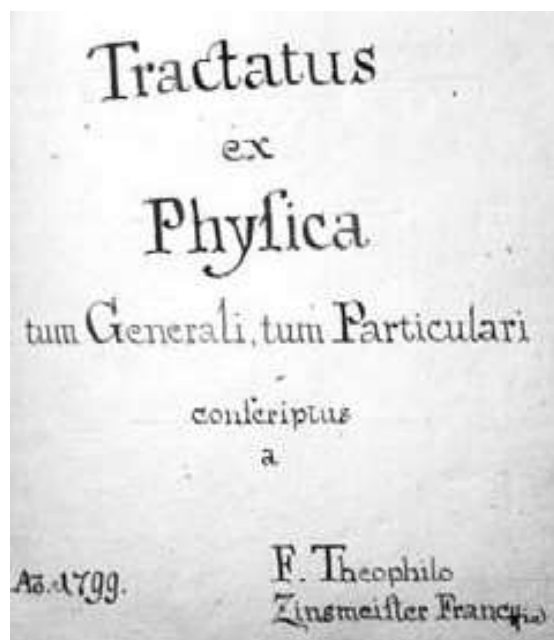

Figure 6-201: The Title page of Zinsmeister’s textbook (Zinsmeister, 1799).



Figure 6-202: Zinsmeister’s sketch of the thermometer (Zinsmeister, 1799, 1:19).

¹⁰⁹⁸ Castul Hieber, *Philosophia Corporum seu Physica: Pars I generalis ex variis / Novissimis Autoribus con gesta ac Systemate ordinata pro annis Praelectionibus P. Castuli Hieber (227 pages)/ Notiones et Definitiones ex Geometria (5 unfinished pages separately paged) (FSLJ-15 b 65)*, 1797, pp. 5, 7-8, 146, 159, 201-205; C. Hieber, *Theses selectiores ex philosophia*. Pedemontium, 1799, p. 18 (thesis LX)..

¹⁰⁹⁹ C. Hieber, *Theses selectiores ex philosophia*. Pedemontium, 1797, p. 21 (thesis 46); C. Hieber, *Theses selectiores ex philosophia*. Pedemontium, 1799, p. 19 (thesis LXIV).

¹¹⁰⁰ C. Hieber, *Theses selectiores ex philosophia*. Pedemontium, 1799, p. 8 (conclusion of thesis XX); T. Zinsmeister, *Tractatus ex Phyfica*. Manuscript FSLJ-1 d 48, 1799; C. Hieber, *Philosophia Corporum seu Physica: Pars I generalis ex variis / Novissimis Autoribus con gesta ac Systemate ordinata pro annis Praelectionibus P. Castuli Hieber*, Manuscript in FSLJ-15 b 65, 1797.

For many decades Ljubljana hosted the main Franciscan theological school, therefore its professors had also to prepare their philosophical lectures including physics almost each year. Most of their individual work remained in manuscripts which are still in the Ljubljana Franciscans’ Library.

In those days, students liked to use their professor’s manuscripts for the preparation of their examination. During the 18th century the professors mostly did not mail their lectures to students as the attachments to emails, they even did not use

copying machines. The students of those times preferred to use their professor's manuscripts and the most beautiful of them was accomplished by the Bavarian Teofil Zinsmeister who later between 1803 and 1816 lectured on mathematics and Greek Language in the Franciscans' Higher Studies of Novo Mesto. Teophil (Teofil) Zinsmeister taught philosophy with physics according to his probable teacher Hieber.

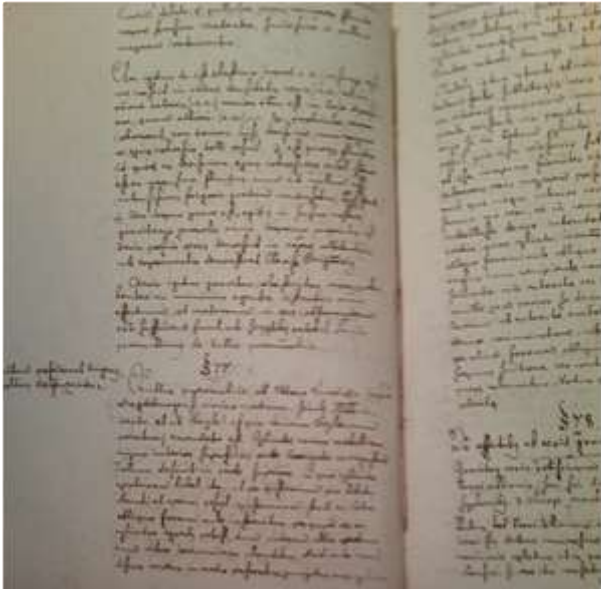

Figure 6-203: Zinsmeister's description of Boyle's *Antilia Pneumatica* and Guericke-Auersperg's Magdeburg Hemispheres. Zinsmeister subsequently added the mention of the Parisian Academician Dutchman Christiaan Huygens and other Vacuumists (Zinsmeister, 1799, 1:76).

For his Ljubljana and later Novo Mesto lectures Zinsmeister produced 169 pages long manuscript on experimental physics (*physica particularis*) and afterwards also 173 pages of theoretical physics (*physica generalis*) although the reverse order was far more common. He also produced an interesting manuscript on theology.

Zinsmeister put beautiful pictures random in his text. He began his manuscript with a paragraph on the nature of simple fire (*de natura ignis elementaris*) and discussed the penetration of light through glass, crystals, or air. That kind of introductory lectures seems somewhat unusual or extraordinary, but Zinsmeister also discussed fire later in his manuscript. He pictured the Florentine thermometer, and noted contributions of Drebell, Daniel Fahrenheit, and René Antoine Ferchault de Réaumur.



Figure 6-204: Zinsmeister's report on the barometer (Zinsmeister, 1799, 1:77).

Zinsmeister explained the phenomena of electricity relatively briefly on fourteen pages of twelve chapters without any illustrations. This seems somewhat surprising because it was just the era before Volta's breaking-through discovery and the electricity studies were extremely popular in Zinsmeister's times. He was interested in an electric spinning-wheel called *Machina Electrica*. Zinsmeister took some interests in the electrical rubbing machine. He described the electricity of fire, while in description of light and of the electricity in glass and metal he believed Benjamin Franklin and his experiments with quadrant. Zinsmeister was experimenting with electricity in nature, but unfortunately, he didn't draw his tools. Zinsmeister specifically dealt with a lightning rod under the German title *Wetterableiter* and cited primarily the writing of Xaverius Epp (b. 1733; d. 1789) on magnetism of electricity, as well as Hungarian Jesuit Paul Mako's opinion on the electricity of the Earth.¹¹⁰¹ Epp and Hungarian Jesuit Mako were very popular in Ljubljana, as Jurij Vega used Mako's book on lightning rods to illustrate the questions in his final exam in 1775. In 1773 Franz Xaver Epp published the booklet for his Munich students, and Žiga Zois bought the item for his Ljubljana Library. Epp divided 146 pages of his book into 111 paragraphs about the

¹¹⁰¹ T. Zinsmeister, *Tractatus ex Physica*, manuscript 1799, 1:3, 19-21, 61, 67, 71-72.

artificial and natural electricity and added the philosophical and metaphysical examination theses.¹¹⁰² On three tables, he classified fourteen images, including a Leiden jar, lightning rods and dangerous experiments with electricity. He referred mainly to the Viennese experts, but he didn't mention the Imhof's introduction of lightning rods in Bavaria. Zinsmeister described the fires in atmosphere according to ideas of Musschenbroek.

Zinsmeister developed his description of air from Bouguer's Peruvian discovery of the changing pressure of atmosphere depending on geographical longitude. Zinsmeister cited Guericke and Boyle's vacuum experiments with whole page filled with descriptions of metallic cylinders and recipients. During one of his later readings of his own manuscript Zinsmeister added the note about the accomplishment of Dutchman Christiaan Huygens, the Frenchman Nollet, and the correspondent member of the Berlin Academy Jacob Leupold. Zinsmeister drew useful sketches of barometer¹¹⁰³ but did not present any figures of air pumps even if they were very popular in those days. Besides the siphon he added the separate paragraph about the Magdeburg vacuum hemispheres according to the Mathias Gabler's theory of force (*De vis corporum*). The Jesuit Mathias Gabler was the professor of physics in Ingolstadt in 1773/74. Additionally, Zinsmeister described earthquakes, winds and sound.¹¹⁰⁴

Zinsmeister devoted most of his 173 pages of the theoretical (general) physics to the repulsive forces. He sketched the first fluctuation in the Bošković's graph of force distance curve and referred to Gassendi's and Nollet's subtle matter as a cause of cohesion.

¹¹⁰² Franc Xaver Epp, *Problemata Electrica*. Vienna; Reprint: Epp, *Problemata Electrica publicae disputatione proposita a P. Franc Xav. Epp S.J. in electorali Lyceo Monacensi Professore Physices p.o. Defentibus Benedicto Knilling, Josepho Hall, Joseph Widman*. Monaci: Joannis Nep. Friz. Pars I (146 pages) pars I (83 pages), 1773 (National and University Library Ljubljana (NUK-8558) acquired from the former Žiga Zois's library as listed in the Archive of Republic Slovenia, SI_AS 1052, Žiga Zois' special accomplishment, Jernej Kopitar's, Schober's, or Zupan's catalogues preserved on unbound sheets, fasc. 19, item No. 23), fig. 3, 120 (fig. 13), 136, 137 (fig. 14).

¹¹⁰³ Zinsmeister, 1799, 1:73-74, 76, 77 (Fig. 25), 78 (Fig. 25 (sic!)).

¹¹⁰⁴ Zinsmeister, 1799, 2:31-32, 1:83-86.



Figure 6-205: Zinsmeister's sketch of the vacuum above the mercury in the barometer and in the round mercury tank (Zinsmeister, 1799, 1:78).

In the marginal notes, Zinsmeister drew the famous Bošković's curve, where he marked the intersection of the curve and axis with the letters. Because Zinsmeister signed his manuscript in 1799 it is obvious that Bošković's ex-Jesuit physics stayed in power a long time after the death of that famous Croatian and was still the fundamental idea in the Franciscan schools even if Franciscans were never in excellent relations with the Jesuits. Bošković was popular in the headquarters of the

Franciscan Friars minors who often quarrelled with the Jesuits, so the Cardinal Rode himself had to make peace among them. The fact proves again that the statements of Ugo Baldini about the quick abandonment of Bošković's ideas after his death is true just for South Italy while Bošković's physics was widely used in Habsburg monarchy several generations after Bošković passed away. Zinsmeister was extremely interested in the behaviour of Bošković's force on minimal distances between the bodies illustrated with the first fluctuation of Bošković's curve of forces.¹¹⁰⁵

¹¹⁰⁵ Zinsmeister, 1799, 2:14, 16 (Figure 1), 20, 23 (Fig. 2), 28, 29 (Fig. 3).

Zinsmeister started his explanations of the forces of motion with equations and relatively intricate computations. He described cohesion with of the redistribution of the same particles of the substance on an unmarked drawing on the marginal side of his text.

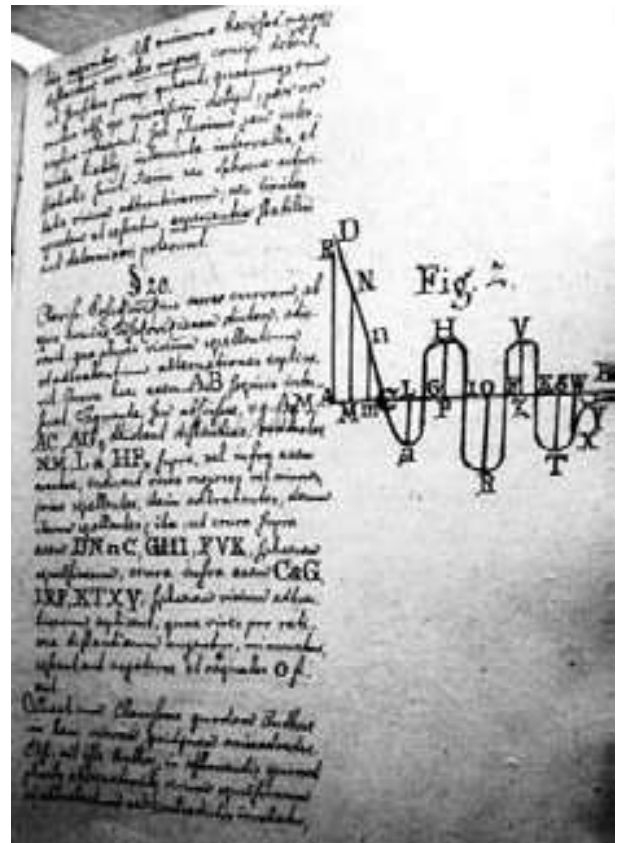

Figure 6-208: Zinsmeister’s description of Bošković’s forces in small distances between atoms of the famous Bošković’s curve (Zinsmeister, 1799, 2:23).

Figure 6-206: Zinsmeister’s description of Magdeburg Hemispheres (Zinsmeister, 1799, 1:83).

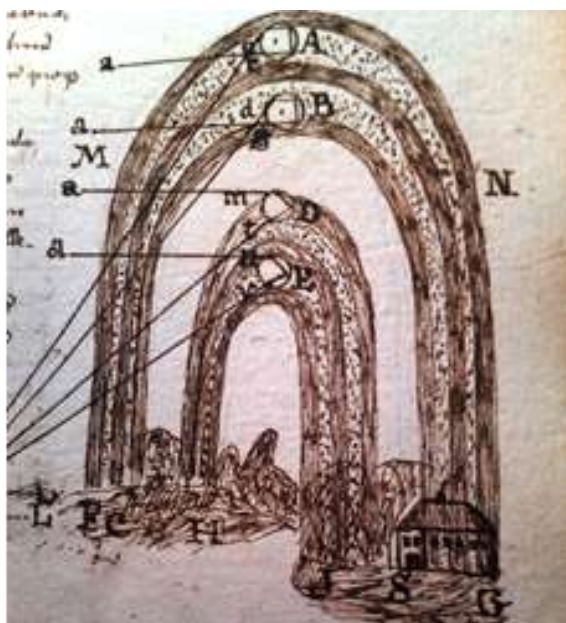

Figure 6-207: Zinsmeister’s figure of the rainbow (Zinsmeister, *ibid.*, 1: p. 17 (The courtesy of Dr. Prof. Miran Špelič, OFM)).

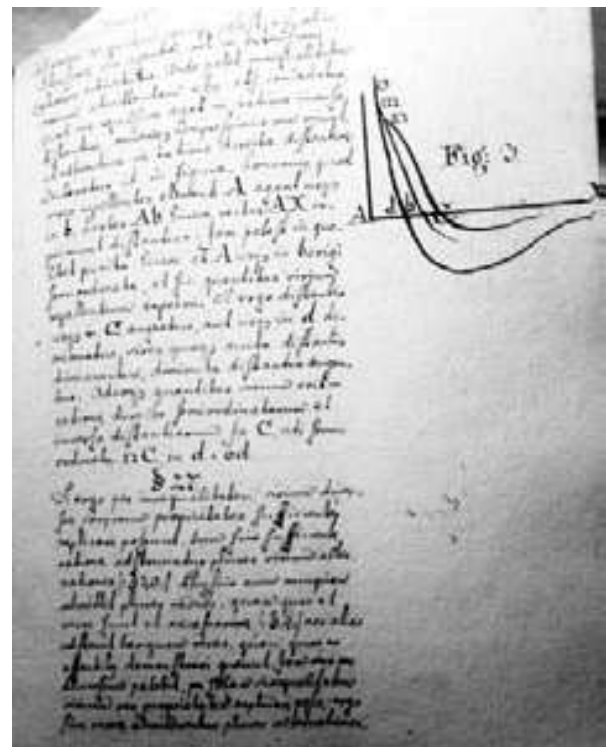

Figure 6-209: Zinsmeister’s exploration of the first fluctuation of Bošković’s forces at minimum distances between particles (Zinsmeister, 1799, 2:29).

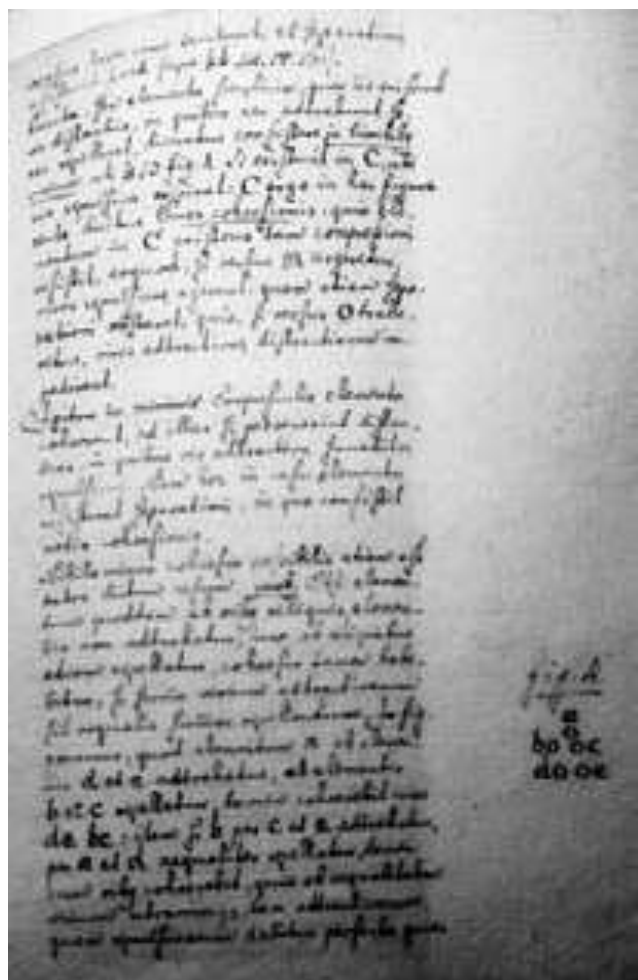

Figure 6-210: Zinsmeister's explanations of molecules (Zinsmeister, 1799, 2:39).

Zinsmeister described the matter according to the Dutchman Pieter van Musschenbroek whose measurements he used. Zinsmeister copied and summarized Musschenbroek's table of numerical values of the power of cohesion between the equal cylinders made of copper, or glass, iron, black or white marble. Zinsmeister was thinking about the cause of gravity in terms of the same speed (or acceleration) of the movement of all bodies in the vacuum. Mathematically, he relied on the central forces, which cause the circular orbit of moving bodies; Zinsmeister described them in detail.

In the third part of his theoretical physics he put in the limelight the problems of static and mechanics of translation. He examined the movement on the inclined plane (ramp) in detail. He sketched the communication vessels as well as the vacuum in a siphon made of capillaries and the cohesion of liquids in containers. He concluded his theoretical physics with more chemically coloured phenomena

of crystallization and fermentation,¹¹⁰⁶ which must have come in handy to Lower Carniola (Dolenjska) lovers of good droplets of wine.



Figure 6-211: Zinsmeister's examination of the connected vessels and vacuums in the siphon (Zinsmeister, 1799, 2:154).

Zinsmeister cited the Jesuit Horvat's physical textbook which immediately on the first whiteboard full of folding images offered sketches of vacuum devices. Already in 1771 Horvat's textbook belonged to the Franciscans' Library of Sveta Gora near Gorizia Town,¹¹⁰⁷ where the famous Slovenian poet Valentin Vodnik used it soon after he ended his school years in Ljubljana in 1781. In 1786, the Emperor Josef II suppressed the Sveta Gora monastery and Horvat's and other beautiful books bind in leather were transported to Ljubljana Franciscans' Library where Zinsmeister had read them. The Croatian Ivan Horvat was one of the most important supporters of Bošković's ideas in the University of Trnava which was moved to Pest in 1777, and seven years later to

¹¹⁰⁶ Zinsmeister, *ibidem*, 2:24, 36, 39 (Fig. 4), 43, 68, 71, 111, 147, 152-153 (Fig. 34-38), 155-156, 159, 167, 169.

¹¹⁰⁷ Zinsmeister, *ibid.*, 1: p. 169; Joannis Baptistae Horváth, *Institutiones Physicae Particularis*. Tyrnavia (FSLJ-21 f 9), 1770, p. 477.

Buda. The Ljubljana Franciscans had bind Horvat's textbooks into the solid vellum whose whiteness later darkened because it was widely used. One of the frequent users of Horvat's books in the Ljubljana Franciscans' Library was Zinsmeister's colleague Ivo Bonelli who taught in Innsbruck but eventually died on duty in Ljubljana taking care of injured soldiers in the eve of the Napoleonic Illyrian provinces. The Siebenburgen (Gradišča) Croat Ivan Horvat was one of the most important proponents of Bošković's ideas. Together with his older colleague Jaszlinszky, he lectured at the University of Trnava. The Ljubljana Franciscans bind Horvat's textbooks into the white hard parchment which is now smeared and worn out from frequent use.

Of course, Zinsmeister was not the only Franciscan who was attracted by the discharge of the vacuum at the time before the cathode ray tubes when the steam engine was the only industrial use of the empty. In 1739, Slovenian southern Franciscan neighbors in the town of Fojnica of Silver Province of Bosnia (*Argentina*) created an interesting physical manuscript on the movement in the vacuum under the domestic goose pen which was used by the Vukovar Franciscan professor of philosophy Joannis Velikanović (Ivan, 1723 Slavonski Brod, 1723-1803 Vukovar) and after him by Francisco Vrsevich (Vrašević) of Fojnica with a dated proprietary entry on 9. 12. 1739.¹¹⁰⁸

6.5.7 Conclusion

As the young Franciscan in Trsat and Klanjec in today's Croatia, Žiga Škerpin learned to love mathematical and technical sciences. He soon became the Franciscan leader with many administrative tasks, and therefore he was unable to fulfil his early mathematical-technical fashions. Anyway, he used his youthful knowledge for the expert acquisitions of contemporaneous and older literature for the Ljubljana Franciscans' Library to enable the scientific research of the future Franciscan generations. His efforts helped his fellow Franciscans of Novo Mesto to organize the public lectures on lower lever in 1746 with some mathematics included, and even the internal Franciscan lectures on mathematics and physics on

the higher level of Novo Mesto philosophical studies after the year 1762. The schools of Ljubljana equally needed good library which Škerpin made use of. Škerpin's book collection enabled Franciscans to become excellent lecturers on mathematical and technical subjects. As did Ljubljana Jesuits a century earlier after the opening of their higher philosophical studies in November 4, 1704, also the Franciscans had to use the foreign imported teachers to begin their newly established schools. The Bavarian Franciscans Hieber and Zinsmeister completely fulfilled the task in the late 18th century.

The Franciscan scientific efforts in Ljubljana brought several new aspects in Central European networks. In many ways, the Ljubljana Franciscans' Library preserved the feeling of old times reading societies of the mid-European lands. During the reforms of Emperor Josef II, the Ljubljana Franciscans' Library was moved across the Ljubljanica River in the monastery of recently suppressed Augustinians. The Franciscans collected the valuable treatises in their library for long centuries but only their leader Žiga Škerpin acquired enough books to enable the successful teaching of the early new sciences. He acquired an extraordinary great amount of the contemporary and older philosophical literature for the Ljubljana Franciscans' Library in the times when the philosophical literature also contained mathematical, physical, and biological sciences in the librarian's expert group numbered ten. No less important were Škerpin's acquisitions in the librarian's expert group numbered twelve containing the medical and pharmaceutical literature. In 1744/45, Škerpin ordered renewed binding of many books which he inherited from his precedents in Ljubljana Franciscans' Library, although that act is valued differently by modern researchers of Ljubljana Franciscans' Library because older covers and some marginalia were lost in the process.

It is believed that Škerpin got many of his new leather-bound beauties almost for free during his frequent travels through Italy and Spain, because he knew very well how to behave in the learned European societies. He brought so many newly issued items to Ljubljana that he had to rebuild the new library facilities in the Franciscan Monastery on today's Vodnik Square in Ljubljana. It is sorry to say that Škerpin's building did not benefit much

¹¹⁰⁸ Hrkać, S., *Filozofijski manuskripti na latinskom jeziku u Bosni Srebrenoj*, Ziral, Mostar 1998, 234; Fojnica OFM Monastery Rk. 44 (manuscript).

his Franciscan descendants because Škerpin rebuilt Škerpin's Franciscan monastery to serve the purposes of Lyceum few decades after Škerpin's death. Much more useful were the books which Škerpin acquired, although the domestic Franciscans were not always educated enough to use them for their lecturing. To fit the demands of the day the Carniolan Franciscans had to import the lecturers from other Franciscan provinces, especially from Bavaria, because the Bavarians knew better the new scientific inventions. With his efforts Škerpin paved the way for the Bavarians Franciscans Zinsmeister, Hieber and others who began the modern mathematical-technical lecturing in Franciscan schools nearly half of a century after Škerpin's death. Their success could be valued by the manuscripts they left, also by the books they used for their writings. In many aspects, we could suppose that the Franciscan lectures on mathematical and technical subjects were not at all inferior compared with the lectures of their more famous Jesuit contemporaries or later lay professors.

The Ljubljana Franciscans for centuries guarded the remains of the first Carniola vacuumist Janez Vajkard Auersperg (Turjaški) under the walls of his church-chapel on today's Vodnik's square, by funny coincidence named after the Franciscan Valentin Vodnik. One way or another, they also began their interesting research in modern vacuum techniques. They have purchased modern literature about them. For their students, the vacuum was discussed in their manuscript textbooks that were not able to get through the printing machines.

The Franciscans of today's Slovenia taught in secondary public schools only in Kamnik and Novo mesto. Nevertheless, they were well supplied with first-class physical literature related to the empty, which was already examined at the dawn of vacuum experiments by Capuchin Valeriano Magni and the Minim priest Marin Mersenne. The Franciscan Scotus' approach to the vacuum suited Valeriano Magni or Torricellian experimental approach much better compared to the ideas of St. Thomas Aquinas in the Jesuitical Suárez' version. There was the huge profound difference between Valeriano Magni's anti-peripatetic ocular observations of vacuum and much more reserved vacuum-related enthusiasm in Kircher's Jesuitical networks or in Janez Vajkard Auersperg's leading political headquarters. The official Papal opinion

about vacuum possibilities was much more patient compared to papal bans against Copernicans, atomism, or early Cartesians which enabled different Catholic interpretations of the results of early vacuum experimentation. The controversial division between vacuists and pleinists left much more space for the intermediate opinions like the one of the atomist Descartes compared to similar disputes resembling the earlier Copernican quarrels or the later antagonisms among Nollet's or Franklin's number of electrical fluids with the shapes of lightning rods included, Stahl-Lavoisier's phlogiston-caloric, or Galvani-Volta's sources of electricity. It was quite possible to develop a solid vacuum technique and retain the doubts in complete void of a vacuum. Unlike the relative outcomes of other similar quarrels, the quest for absolute vacuum never ceased to be an unresolved Gordian knot puzzle.

6.6 Valvasor about Vacuum and Thin-walled Sculptures

6.6.1 Introduction

After studying the vacuum books of the Auersperg prince's library and similar Franciscan treasures, it's right to describe Valvasor's book treasures as he became a heir of the Auersperg's Baroque Spirit. Many books in Valvasor's library and his own research was focused on vacuum technique. In many ways, Valvasor surpassed his example of the provincial governor Wolf Engelbert Auersperg because Valvasor purchased more extensive readings in foreign languages from faraway countries. Valvasor was particularly interested in Boyle's vacuum pump. While Wolf Engelbert Auersperg and his brother Janez Vajkard Auersperg's pioneering vacuum researches followed their personal acquaintances with Guericke and V. Magni as well as the correspondence with Kircher, Valvasor's mature opinions about vacuum emerged from his correspondence with Halley.

Valvasor wrote his major studies of the properties of materials in a total of nine volumes of his *Lumen naturae* and *Flos Physico-mathematicus*. Both manuscripts were lost after the sad Valvasor's debt settlement needed to avoid bankruptcy. Therefore, Valvasor's knowledge of vacuum and foundry techniques can only be estimated from

three sources: by reading his books sold to Zagreb metropolitan library, reviewing scientific instruments listed in his legacy in Krško, and studying his thin-walled sculptures.

6.6.2 *Thin-wall Statues*

The foundry business was not foreign to Valvasor's Jesuit teachers in Ljubljana, but Carniolan Janez Vajkard surpassed them. His knowledge of metallic materials has increased his interest in alchemy, mainly under the influence of the Royal Society of London and its important member Robert Boyle.

Valvasor bought the stand and pillar, and according to his order Wolf Weisskirch(n)er from Salzburg made the mold of St. Mary's statue.¹¹⁰⁹ Prior to the Christmas holidays just before midnight on 16 December 1681, Valvasor casted his sculpture by his innovative foundry procedure in front of the Karlovac Gate on Karlovška Street no.15, where Krištof Schlag(s) established itself as the forerunner of the later bell-foundry family of Samassa.

On the Good Friday of 27. 3. 1682, the statue was transferred in front of the nearby Jesuit church of St. Jacob within the Jesuit College. There was no road Dolenjska cesta in those times, so traffic stop was not needed. The architect Marcello Genovese (Genevese) lifted Valvasor's art on a pedestal, which was built in the meantime during wintertime. The ceremonies were attended by the rectors of Jesuit colleges of Gorizia, Trieste and Rijeka, and the news of Valvasor's invention quickly spread.

Valvasor reported to Secretary of the Royal Society Thomas Gale about his Ljubljana Marian statue and about new procedures for its casting; Valvasor earned extraordinary attention as rarely any Carniolan inventor sooner or later. In 1687, E. Halley at Phil.Trans. published Valvasor's letter to the secretary Thomas Gale about a new way of casting metal sculptures with a beautiful sketch of a statue of god Pan with panpipes. Probably Valvasor also casted Pan, although today we do not know where he put that statue.

Valvasor's friend Halley has edited Phil.Trans. between 1685-1693 and published there other Valvasor's works. The previous editor of Phil.Trans. Robert Hooke was angry and felt neglected, as it was his old way of behavior. Hooke was jealous, so, he cruelly hinted that Valvasor's inventory of thin-walled casting does not bring anything new, except the use of other chemicals, mostly one-third of the "bismuth" or zinc brass, which the pouring of melted alloy easier.¹¹¹⁰ In fact, this novelty was irrelevant only at a first glance.

Hooke and the master of the English Foundry Guild, however, approved the publication of the Valvasor's procedure after the art critics Dr. Aglionby compared Valvasor's novelties with the practices of London craftsmen.¹¹¹¹ Valvasor's peer Aglionby was a member of the Royal Society, and he also corresponded with the famous Locke. Valvasor was inspired to a certain extent by German potters as well as by the Japanese alloys about which he learned during his love adventures in today's Tunisia and Libya in the summer of 1669. Additional to the chemical composition of the alloy, despite of Hooke's despair, Valvasor improved the distribution and design of the casting channels,¹¹¹² since he was well acquainted with his business. Today, we do not know whether a pump was used when casting, which, in view of Valvasor's knowledge of vacuum technology, is quite likely.

Thomas Gale (* 1635/1636 Scruton in Northern Yorkshire; † 1702) was slightly older than Valvasor. He grew up as a single son, studied in Westminster, and in 1655 he entered the college of the Holy Trinity in Cambridge just before Newton. Gale graduated in 1659 and obtained a master's degree three years later. The university has published some of his glorifying verses upon the death of Oliver Cromwell, which brought him a reputation in society. In 1666 he became a professor of Greek language in Cambridge, and in 1672 he became a Headmaster in the school of St. Paul, where Valvasor's later friend Edmund Halley was among his students. On 6 December 1677, Gale was elected to the Royal Society of London,

¹¹¹⁰ Reisp, 1987, 8; Paulin, Trbižan, 1996, 264.

¹¹¹¹ Reisp, 1983, 176.

¹¹¹² Trbižan, 2003, 177, 183.

¹¹⁰⁹ SBL, 3: 220.

almost exactly a decade before Valvasor, and in January 1686 Gale became a secretary of the Society. Gale's assistant became Halley, who performed that duty until 1699, and from that time Halley knew Valvasor's letters sent to London. A few years later, Halley traveled through Istria and Kvarner bay, looking for an appropriate port for the disembarkation of English and Dutch military during the War of the Spanish Succession; unfortunately, his friend Valvasor died a decade earlier. According to the king's order, Gale listed so well all the monuments in London that the city rewarded him with a plaque. As a specialist for monuments, he was especially interested in Valvasor's casting of sculptures. Already at the beginning of the 17th century, gypsum molds were poured with a liquid clay mixture for the richer Brits, who wanted to get rid of an annoyance from that funny room to where even the emperor was walking on foot. Such toilet bowls were very expensive, and the water was still absorbed in them.¹¹¹³ That's why Gale and his hygienic colleagues searched for different new materials and Valvasor's similar innovative casting processes. Foundry was well developed in the immediate vicinity of the Royal Society's headquarters on the eastern end of London. In 1570, Robert Mot founded a foundry that later became the Royal Whitechapel Bell Foundry. It was mainly based on the casting of London Big Ben and the American Pennsylvanian Liberty Bell of 1752. The center of English iron-foundry was in the valley with the famous name of Ironbridge; there they developed the iron industry, which soon after Valvasor's death made great progress by Abraham Darby's invention of the use of coke to produce pig iron in a blast furnace in 1735.¹¹¹⁴

The chemical analysis and electronic microanalysis have shown that the contains of the alloy of Valvasor's statue of St. Mary at St. Jakob's has only a hundredth of a percent of bismuth, and therefore almost 16% of zinc. As if the Baroque master had learned the modern experiences that exposed bismuth as a dangerous fragile agent in copper alloys, where it should not exceed 0.005%. By adding zinc, 4% of lead and over 2% of tin,

Valvasor reduced the melting point of the alloy by 120°C. He received the "most liquid" substance for casting thin-walled sculptures and overtook the achievements of all his contemporaries. As an experienced foundry expert, he developed a sophisticated feeling for the beneficial influence of smooth surfaces of the channels to better the flow of the alloy in the mold of the statue. He took advantage of the important effects of surface coating, so he was able to avoid unwanted wax components in coatings. He certainly got raw materials from the local Carniolan and neighboring places, although he did not publish the details. On today's Slovenian soil, twenty-six iron and blast furnaces and blast furnaces worked in Valvasor's time. In Carinthia, they operated already in the 15th century. Valvasor probably obtained his mineral zinc carbonate (calamina, zinccum, smithsonite), from Rabelj (Cave del Predil, Raibl) in Carinthia-Tarviso. He might have obtained a copper and zinc alloy "golden copper (aurichalcum)" in Cerkno, where the copper ore was dug in the 15th century. Shortly before Valvasor castings, Hans Sigmund Ottenfeld was granted permission for the lead mine in Črna na Koroškem (1665). Four decades before Valvasor's birth, the miners of Counts Thurn-Valsassina began digging lead in the northern Pliberk and Peca mountain, also in the Iron Caves (Železna Kaplja) and Rabelj.¹¹¹⁵

The impressive expenses for Valvasor's St. Mary's statue were settled by Carniolan provincial Estates General, and even the baron Janez Vajkard received some gold coins for his pocket. He bought the manor Bogenšperg, but he was never able to pay off all the purchase, so that he urgently needed additional incomes. Five years after his English publication in London his casting process of metal sculptures was translated in the first volume of the new magazine *Acta Eruditorum*, which, at the initiative of the famous scholar Leibniz, began publishing in Leipzig. The Latin publication in the first issue of this famous magazine shows, the importance of Valvasor's idea among the foreigners, while he prematurely died in Krško without much money left. Nobody is a prophet in the homeland, and especially not in Carniola. Valvasor wanted the outmost liquid melted alloy, which he poured into the intermediate space of the covered basic form of the statue. In that regard,

¹¹¹³ Lambrozzi, 1994, 93.

¹¹¹⁴ Ruschitzka, 1985, 49.

¹¹¹⁵ Paulin, Trbižan, 1996, 263, 264, 267-268; Paulin, 1998, 63, 65, 67, Šorn, 1984, 167; SBL, 4: 82.

Valvasor carefully measured the increment of the size of the statue model due to the added layer of metal. His quality of the cast was, of course, not comparable to thin layers and thin films based on modern vacuum processes of surface overlapping, which were still unknown to Valvasor.

When the statue was made, Valvasor removed the mold and the tiny channels through which he poured the alloy. The cut-off casting system was prepared for "reuse";¹¹¹⁶ he would certainly not have done this if he did not get many other sculptures done, although currently we know only the one in Ljubljana.

During his reporting period to the Royal Society, Valvasor has not yet able to make any sculpture larger than nine feet (3 m) but he did not doubt that he could also face higher challenges.

Valvasor announced that he will cast the statue of Emperor Leopold on the horse. Valvasor intended to immortalize the emperor in a supernatural size to glorify his visit to Ljubljana in 1660. The Emperor had already agreed his castings with the Carniola's provincial states (Estates General),¹¹¹⁷ who were willing to cover the costs of Leopold's monument. Valvasor also awaited the end of the Turkish threat, which began in July 1683 with the Turkish siege of Vienna. After lunch on August 7th, 1683, Valvasor as the captain of one fourth of Carniolan troops hurriedly left Ljubljana as the commander of the Carniolan troops defending the endangered Styria.¹¹¹⁸ He postponed his readings of Boyle's book on vacuum techniques for a few months to replace his pen with a swashbuckling sword and a gun. On the feast of all the saints, he was already home, but he did not cast the planed Leopold's statue, because Valvasor was under the earth already for a long time at the end of the "Viennese War" in 1699.

Valvasor description of the process of casting thin-walled sculpture was the first internationally recognized technical document of the Carniolan inventor in the field of metallurgy and engineering in its entirety.¹¹¹⁹ In any case, the statue of St. Mary was not the only product of an experienced

Valvasor's castings, although others are still unknown to us.

6.6.3 *Galileo's Circle in Valvasor's Networks*

Valvasor was aware of the technical merits of Galileo's followers. Valvasor advanced his knowledge of foundry and vacuum techniques in his carefully selected home library, and he learned a lot during his many years of youthful journeys. He also read older opinions on the vacuum, including Sebastian Fox Morcillo of Seville, who studied classical philosophy in Leuven (Louvain) in the south of then Spanish Netherlands. The Spanish King Philip II named him as the guardian of his son, Carlos, but Fox Morcillo sadly drowned on his way to a new job. Valvasor read the first posthumous reprint of Fox Morcillo's philosophy of the nature of Aristotle and Plato, dedicated to Fox Morcillo's intended employer Philip II. In the eleventh chapter of the first of his five books, Fox Morcillo described the infinity and vacuum. According to Parmenides, God had the opportunity to create infinity, but above all, Fox Morcillo referred to Plato's Timaeus and rejected the empty space without a substance.¹¹²⁰

Valvasor was interested in the works of Galileo's predecessor Baldi, who studied mathematics at Padua together with Galileo's friend Marquis Guido Ubaldo del Monte. In 1570, the teacher of mathematics Commandino asked Baldi him to translate Heron's study of vacuum devices from ancient Greek to Italian. He published it only in 1589 with an introductory study of the history of mechanics. Only the translation enabled the development of Heron's ideas about the reality of an empty space in Galilean visions of matter composed of atoms separated by a vacuum. Valvasor bought the Italian translation of Heron, published by Federigo Commandino's student Alessandro Giorgio of Urbino (1592); he additionally received Agathus Cario's German adaptation of Commandino's Latin translation published in the year 1688.

Valvasor also kept Baldi's most important work on Aristotle's mechanics, published posthumously in 1621. Baldi even attributed to Aristotle a task with an emptied receiver; this was certainly not the

¹¹¹⁶ Paulin, Trbižan, 1996, 267.

¹¹¹⁷ Radics, 1910, 146.

¹¹¹⁸ Reisp, 1983, 164.

¹¹¹⁹ Paulin, Trbižan, 1996, 263.

¹¹²⁰ Fox-Morzillo, 1560, 28^r, 29^r, 30^v-31^r.

original thought of Aristotle, who did not even approve of the vacuum. Baldi returned to the vacuum again by thinking about the gravity fed water system at the end of the book.¹¹²¹

The Jesuit Francesco Lana Terzi proved to be among the best Kircher's students at the Roman College. Valvasor bought the first two parts of Lana's Lessons on Natural History, while sixty years after the printout Bernard Ferdinand Erberg acquired all three parts for the Jesuits of Ljubljana. The Franciscans of Ljubljana also used Lana's book. The main admirer of Lana's vacuum aircraft was Frančišek Jožef Thallmainer who became a head of Bishopric library of Ljubljana (today Seminary Library) in 1742. Thallmainer owned at least 476 books of his own including two Lana's works. Lana accurately described Torricelli, Boyle's and other experiments with gases and vacuum. He trusted Kircher and Schott, but criticized Galileo.¹¹²² In 1670, he excelled by his plan of evacuated copper-balls aircraft and became a fellow of the Royal Society of London several years before Valvasor.

6.6.4 *Boyle's Vacuum Pump for His RS Fellow Valvasor*

Valvasor bought six Boyle's prints, among them the Geneva Collection (1680) in thirteen volumes with twenty-five major books. Valvasor's enthusiasm for Boyle can be expected, as three Boyle works were also offered in the new Ljubljana bookkeeper Mayr's shop in 1678. Valvasor was fourteen years younger than Boyle; during his stay in Paris and England¹¹²³ in the time of Boyle's final resettlement from Oxford to London in April 1668, Valvasor became acquainted with Boyle's vacuum experiments.

Valvasor bought Boyle's Hydrostatic Paradox (1670) with three nice groups of images of capillaries in the vessel, the pressing of liquids and the consequences of the difference in pressure. Boyle's experiments were repeated by Valvasor at Bogenšperg to check the operation of the alleged siphons under Lake Cerknica, which Valvasor's friend Halley then demonstrated in front of the London Royal Society in honor of Valvasor's

election among new members in 1687. Boyle lived in Pall Mall in those times, but he gradually withdrew from his public engagements, ceasing his communications to the Royal Society. Valvasor as the only Carniolan member of this famous Society witnessed the extremely high Londoner respect of Carniolan Baroque science and technology.

According to an address to the reader and in the preface (1680), the Hydrostatic Paradox was the continuation of Boyle's "Tractatus de Aëre" (1672). It was sold by Mayr in Ljubljana, and after Boyle's death it was translated into English. Boyle compared the pressure in the liquid with Torricellian experiment with a vacuum above a mercury-filled tube. In his address to the reader, Boyle rejected Hobbes's attitude towards a vacuum, which Boyle also deleted as a political antagonist of the royalist Hobbes. All four Valvasor's books from Boyle's Geneva collection (1680) were devoted to vacuum experiments, along with two others in the Geneva edition of 1683. Boyle wrote the first and longest vacuum booklet as anthology of his letters mailed to his nephew Carl Count Cork (1680). Boyle added to them a decade earlier Hydrostatic Paradox with two groups of images placed between two panels of sketches of vacuum devices. This was one of the few illustrated booklets in Boyle's Geneva collection, from which Valvasor learned his new views on the secrets and on the science of empty. Boyle began with Torricellian and Guericke's achievements, but he skillfully promoted Hooke's abilities and completed forty-three experiments on December 20, 1659,¹¹²⁴ when Valvasor already left his schooling and started a full decade of his youthful adventure journeys.

Boyle also included his second vacuum booklet *Defensio doctrinae de eatere et gravitatione aeris* in his Genevan anthology of 1680, which Valvasor also bought. Boyle misspelled the name of Blaise Pascal as Monisieur Paschal; Gassendi informed Boyle about Pascal's work which might have caused the misspelling. Boyle valued Pascal's vacuum experiments;¹¹²⁵ so, it is all the more surprising that Boyle's colleague FRS Valvasor did not buy Pascal's works as Valvasor had opportunities for his shopping during his travels in France and England. Valvasor arrived in France

¹¹²¹ Baldi, 1621, 37, 48, 54, 159-161.

¹¹²² Lana, 1686, 2: 176; 1684, 1: 175, 177-178; 1692, 3: 214-215, 238-239, 297.

¹¹²³ Mayr, 1678, 51-52; Reisp, 1987, 7.

¹¹²⁴ Boyle, *Nova experimenta* 1680, 2-3, 154.

¹¹²⁵ Boyle, *Nova experimenta* 1680, 13; Boyle, Robert. *Defensio doctrinae* 1680, 10; Boyle, 1999, 3: 26, 33.

five years after Pascal passed away¹¹²⁶ when everyone spoke of his prematurely dead genius. Pascal's descriptions of experiments were bought by Valvasor's colleague in their joint debates in Wolf Auersperg's palace, Baron Erberg, for his library in Ljubljana, later transferred to the nearby Dol.

Boyle devoted his third vacuum booklet to early experiments with *Machina Boyliana*. He referred to his New Vacuum experiments, to Mersenne's Compression Researches and to the measurements of Florentine Academics. Boyle invoked the most important Englishmen of his era to witness his vacuum researches in the Pall Mall rooms of his elder sister, who shared his scientific pursuits. The gentlemen guests gave to his reputation an additional weight, as it was a nice habit of those days. He described the freezing of steam by lowering its temperature when pressing under the weight of a mercury column. In his critique of Hobbes, he cited his older experiments in a mercury barometer.¹¹²⁷ Boyle rejected Hobbes by Guericke and Torricelli's experiments. Boyle devoted his final ending chapter to the storage of foods in a vacuum, which particularly impressed Valvasor. In June 1670, Boyle saved a pint of French wine in a vacuum. In July 1671 he took out and assured his friends gathered around his happy well-dressed table that the wine retained purity and color. Valvasor was not invited as he left England earlier. Valvasor and his teenaged sons in Bogenšperk did not drink much wine despite the care of Valvasor's first wife. Nevertheless, Boyle's idea of storing wine has deeply touched Valvasor's soul along the Sava riverbanks full of vineyards.

In 1682, in Geneva Boyle communicated the continuation of his physics-mechanical experiments with excess pressure of compressed warm air including poor animals put in vacuum. In the study of overpressure, the process of pumping out of the vacuum was reversed, which allowed the steam engine to develop in those and later times. With the help of inventor Denis Papin, Boyle experimented between 11 June 1676 and 5 September 1677 and illustrated his accomplishments on six full-size plates at the end of his book. Like Boyle, Papin was also successful in his dealings with overpressures and vacuums.

After his settlement in Bogenšperk, Valvasor bought the first volumes of *Phil.Trans.*¹¹²⁸ and among them read a report on the first Hooke's and Boyle's experiments with a vacuum pump in front of the Royal Society on 15 February 1665. In Mayr's bookshop in Ljubljana, Valvasor studied Boyle's reports of very cruel experiments with ducks in the emptied vacuum vessel¹¹²⁹ that would of course, trigger a lot of severe protests in the modern Animal Protection Associations. Valvasor immediately began to write to the secretary of the Londoner Royal Society Gale. Valvasor proudly wished to publish his own research in *Phil.Trans.*

In addition to the collected works, Valvasor also bought Boyle's discussion of luminescence *Noctiluca* (1682), which was particularly close to Valvasor, since the first researchers of the luminescence came out completely from alchemical traditions. Boyle first described Baldi's hermetic phosphorus, and then the work of German Daniel Krafft. He observed the shimmering in a vacuum and summarized the process of producing luminophore *Noctiluca* (*Lampyrus noctiluca* worm) according to the habits of then alchemists.¹¹³⁰ Boyle dealt with luminescence in the air and even in ice also in vacuum of *Antilia Pneumatica*. Boyle published his own letters as then popular kind of discussion. He concluded with chemical paradoxes in response to the Jesuit Kircher's (1646) claims which Boyle of course hated as a devoted Protestant. Boyle wrote in the form of letters to Dr J.B. and ended up with chemical paradoxes. Boyle's interest in luminescence was also the answer to Kircher's (1646) allegations about it. Like Hobbes, Kircher did not believe that the vacuum pump indeed removed all the substances. Of course, Boyle disliked the fierce Jesuitical versions of Catholicism.

Boyle quoted Kircher's description of luminescence (1646), which was purchased by both Wolf Auersperg and Valvasor in Boyle's book on experiments and Reflections. The Jesuit Procurator Francisco de Florencia (1619/20 Florida Espanola-1695 Mexico) sent to Kircher a dissolved

¹¹²⁸ Valvasor acquired the books which the editor Oldenburg published as volumes 1665-1669 in Amsterdam (1674, 1675) as an editor of a private journal.

¹¹²⁹ Mayr, 1678, 84; Boyle, 12. 9. 1670. *Nova experimenta pneumatica de respirationem spectantia. Phil.Trans.*

¹¹³⁰ R. Boyle, *Tractatus Scripti ab Honoratissimo Roberto Boyle Nobili Anglo*, 1693, 5; Boyle, 2000, 269, 270-271, 281, 291, 295, 303.

¹¹²⁶ Reisp, 1983, 84.

¹¹²⁷ Boyle, *Tractatus*, 1680.

Table 6-17: Slovenian admirers of vacuumed balloons of Francesco Lana Terzi

Title of Lana's book	Owners
1670. Prodomo ovvero saggio di alcune invenzioni nuove premesso dell'Arte Maestra. Brescia	Auersperg in Ljubljana; Jurij Andrej Triller count Trilek in Ribnica castle, Hallerstein in Beijing
1684, 1686, 1692. Magisterium Naturae et Artis. Opus Physico-Mathematicum. I–III Brescia, Parma: Ricciardi	Jesuits of Ljubljana on 1752; Valvasor's copies of 1684 and 1686; Hallerstein in Beijing, NUK-8461, Thallmainer (SKLJ-T VII 14-16/r).
1723. Placita Physica de motu transpirationis: deprompta ex P. Francisco Tertio de Lanis... Antonio Vanossi... Viennae: Wolfgang Schwendimann.	Bookplate of Frančišek Jožef Thallmainer (SKLJ-T I 32 č)
1724. Placita Physica de sympathia et antipathia deprompta ex Franc. De Lanis S.J. Honoribus. – dicata... Antonio Vanossi . Viennae: Wolfgang Schwendimann.	Škerpin's acquisition for Franciscan library of Ljubljana (FSLJ-20 f 53), W-1531-NUK-8297, Bookplate of Thallmainer (SKLJ-T II 31 č)
1743. Artificia Physica selecta ex Tomo III-io Magisterii naturae et artis Franc. De Lanis S.J. Honoribus etc. Inscripta. Graeci: Widmastatten	W-1529-NUK-8291
1744. Tractatus de motionibus magneticis ex operibus R.P.F. Tertii de Lanis excerptus, et laureatis honoribus J.C. de Cerroni provincialis Styriae...Antonio Vorster... Graeci: Widmastatten	Friars Minor Conventual (Minorite) monastery of Ptuj- F I 629
1745. Tractatus de motionibus magneticis ex operibus R.P.F. Tertii de Lanis... Antonio Vorster... Graeci: Widmastatten	Friars Minor Conventual (Minorite) monastery of Ptuj- D II 49

was kept near full, so that then the under basin filled, and a third basin put into the under, with severall holes pierced in the bottom, would continue with water in it, but the water of the upper basin decreasing - and the communication with the under at length ceasing, the water of the under basin would in some time be drawn of, and the third basin, with the holes in the bottom, would be left dry very well representing the manner of the replenishing and evacuating of the Lake of Lixchnitz, as Described by Mr. Valvasor,

The society adjourned till after 7 Holydays

Figure 6-212: Report on Halley's verification of Valvasor's siphon theory of water flowing in the underground of Lake Cerknica in front of RS on 14 December 1687, immediately after Valvasor's election to the Society (Archives of the Royal Society in London, Letter Book).



Figure 6-213: The cover page of the Cabeo's book about magnets (1629) kept by Valvasor (photographed in the Oklahoma University History of Science).

luminescence material from Mexico so that Kircher could pass the news to the Emperor himself. Kircher used the data of Monardes who was known for his first description of tobacco.

Boyle referred to Glauber as far as the colors of metals were concerned. Valvasor had so greatly respected Glauber that he had collected as many as his twenty-seven books; certainly, also because Glauber spent several years in Vienna. Boyle concluded with a description of the luminescence of Bologna stone and especially of precious stones.¹¹³¹ After a hundred and five pages about the theory of matter consisting of particles, Boyle made ten experiments described in his last forty-two pages. In the sixth part he studied Glauber's salt, and in the ninth part he referred to Helmont and Paracelsus' Alkahest, which in many ways became the basis of Boyle's thoughts.¹¹³² One of the discoverers of phosphorus, Kunckel, later criticized Alkahest with the conclusion that no vessel was able to keep it. Similar problems bothers the modern fusion reactor as no container is strong enough to withstand its heat. A phosphorus researcher and Viennese economic adviser Becher also discussed Alkahest; Valvasor has acquired a dozen of his books, while Wolf had only three. Valvasor bought four more major Kunckel's works in German Language, while Wolf had died before they were issued; the first professional Idrija pharmacist E. Freyer also acquired Kunckel's book in German Language. Valvasor was very interested in luminescence and asked RS in London to send him the instructions for production of phosphorus of all species, according to the report by Irish bishop-mathematician George Ash,¹¹³³ a friend of the writer Jonathan Swift who loved to ridicule RS. Valvasor also tried to build a luminophore from a kind of glow worms, but the resulting substance was not persistent. In Valvasor's legacy in Krško, after his death, a "brass black device in the shape of a night-lamp"¹¹³⁴ was also recorded, which was also commonly used in Boyle's books under the name of luminophore Noctiluca. Unfortunately, the inventory commission members did not describe the composition of Valvasor's luminophore in more detail.

¹¹³¹ Boyle, 2000, 269.

¹¹³² Boyle, *Chymista scepticus* 1680, 39, 65, 69, 78, 115, 119, 123, 139, 133, 139, 145.

¹¹³³ Reisp, 1987, 104.

¹¹³⁴ Radics, 1910, 317.

6.6.5 Boyle's Antagonists

Valvasor bought Cabeo's Magnets dedicated to the French King Louis XIII. Cabeo attributed the magnetic phenomena to the alleged movement of the masses of air, which were first expelled by the electricity, and then the air returned to its original position and pulled enough particles with it. Both Boyle and Galilean heirs at the Florentine Academy Del Cimento investigated the vacuum to confirm or disprove Cabeo's assumptions. In the second book, Cabeo rejected the opinion of the physician of Queen Elizabeth W. Gilbert on changing the electric attraction in moisture and especially in water. Cabeo specially sketched the attraction between the magnetic sticks under water.



Figure 6-214: Cabeo's testing the operation of a magnet under water in Valvasor's collection (Cabeo, 1629, p. 186). (Photographed in the Bizzell library of Oklahoma University).

Later, Cabeo, together with his Ferrara fellow citizens, opposed the hydraulic ideas of Galileo's student Benedetto Castelli on the supposed regulations of the River Reno, supported by Pope Urban VIII. As a Jesuit, Cabeo did not recognize the vacuum as it was supposed to disturb the local

movement,¹¹³⁵ although Cabeo also published a great book about meteorology.



Figure 6-215: Cabeo's attempts to break the magnet in Valvasor's collection (Cabeo, 1629, p. 81). (Photographed in the collection of the history of science with the permission of the University of Oklahoma).

Valvasor read the continuation of Cabeo's vacuum survey of the other Jesuit, Kircher, as Valvasor owned all Kircher's works. Kircher's magnet for lifting large weights impressed Valvasor, who acquired his own powerful magnet. With it, he could lift the weight of the iron which forty times surpassed the weight of the magnet. Upon his death, Valvasor left his extraordinary magnet in his house in Krško:¹¹³⁶ it would be interesting to know where this miracle of science is hidden today.

Kircher was interested in the operation of the magnetic force in a vacuum. Kircher nicely illustrated his vacuum device and showed how diluted air draws water from the container up in the tube. Water then pours through the periphery of the container on the floor or even back into the

¹¹³⁵ Cabeo, 1629, 28, 59, 72, 93, 108, 178, 181-188, 217, 220, 334, 341.
¹¹³⁶ Radics, 1910, 318.

container as a nice kind of perpetuum mobile, which later turned out to be an illusion. Kircher called those fountains in his third book the "hydraulic machines".¹¹³⁷



Figure 6-216: The title page of Voigt's collection of physical questions with which Valvasor "wasted time" in Bogenšperk.

Valvasor bought twelve Schott's mathematical-technical manuals at his most complete Carniolan collection of Kircher's works, since Schott was the most important Kircher student. Valvasor's was interested in the invention of a vacuum pump, which Schott first described and illustrated. Valvasor quoted Schott's works. He also quoted nine Kircher books in Valvasor's Glory (Slava) as Kircher was the author whom Valvasor used the most. Valvasor's role model Volf Auersperg had eight Schott's works: of course, just like Valvasor, Volf (Wolf) Auersperg acquired all those Schott's writings connected with vacuum techniques. Wolf's brother, the prince Janez Vajkard Auersperg, assisted Guericke in his vacuum experiments in Regensburg, and Janez Vajkard Auersperg closely collaborated with Kircher. Six letters sent from Janez Vajkard Auersperg's rooms to Kircher in Rome were

¹¹³⁷ Kircher, 1654, 419.

Table 6-18: The Count Janez Vajkard Auersperg writes to Kircher (in 1654 he became a prince)

Date	30. 5. 1651	9. 2. 1654	27. 10. 1655	3. 5. 1661	12. 11. 1665	23. 4. 1671
Place	Vienna	Regensburg	Vienna	Vienna	Vienna	Ljubljana

preserved;¹¹³⁸ of course, he wrote to him in Latin language, because Kircher would not understand Slovenian scripts. Janez Vajkard Auersperg sent the second letter just before making a famous experiment with horses and vacuum hemispheres in Regensburg with Guericke, and he wrote his last letter mailed to Kircher from Ljubljana a little before Valvasor settled in Bogenšperk. Kircher's and similar fundamental scientific researches were clearly closer to Baroque Ljubljana, than they are today.

Valvasor acquired Voigt's book of *Wasting the Time for Physics* in its second edition. An educational booklet with two hundred responses to interesting physical and biological questions was written just nice for Valvasor's noble soul. In his preface, Voigt devoted his work to Wittenberg's professor of medicine the Lutheran Daniel Sennert, whose discussion of heat and fevers Valvasor read in the collection of his model Wolf Auersperg. The rector of the main school in Güstrow, Voigt, discussed opinion of Valvasor's chief associate the Nurnberg native Erasmus Francisci, who was at that time one of the most popular writers of scientific literature. Certainly, the Franciscans of Ljubljana also read Erasmus Francisci's books.

Voigt discussed acoustic experiments with the Dionysius flute. Voigt compared the smallest animals with atoms. He supposed that in a grain of smoked aromatic camphor one could find a million times more atoms than we could even count. Despite of Boyle's and Guericke's experiments, Voigt did not believe that any perfect vacuum is attainable. Was he wrong?

6.6.6 Conclusion

Valvasor did not complete his schools without higher university studies; he preferred to put his school bag in a corner and enjoy his fourteen years of youthful travels around the world. So, he became acquainted with the leading ideas and at

the same time with the most expensive physical devices of his era, namely, a vacuum pump. He correctly realized that the focus of research on vacuum techniques had moved to English Boyle's networks; Valvasor therefore bought all Boyle's works on a vacuum pump and became a member of the Royal Society as the first and only Carniolan and Slovene of those times. There Valvasor became a friend of Boyle's colleague Halley. Valvasor spent his time in studying the properties of new materials. He crowned his pursuits with an ingenious procedure for casting the best thin-walled sculptures of his time, which brought his glory throughout the whole Europe. Does he deserve a memorable inscription under his Mary's statue in Ljubljana, a unique monument of Carniolan and Slovenian knowledge that would glorify the master for many centuries, as the Jesuits of those days stated?

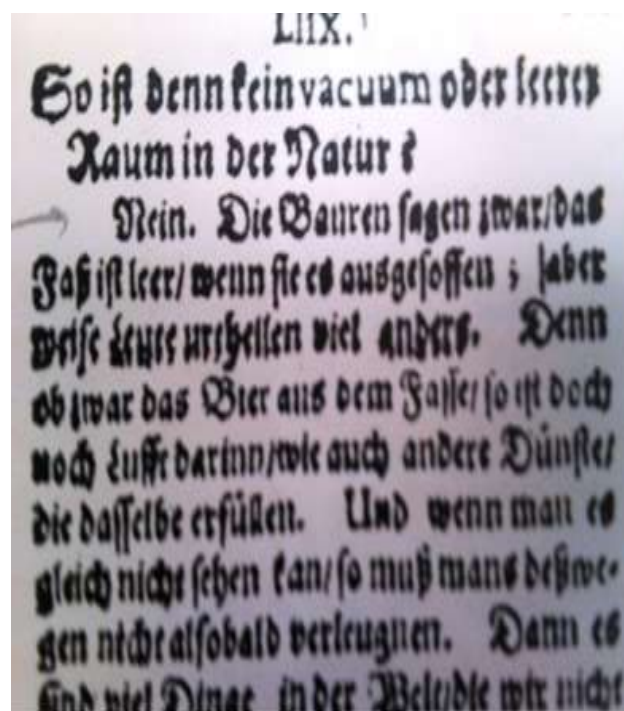

Figure 6-217: Voigt's 58th question with the answer about the vacuum physics and Guericke's experiments.

¹¹³⁸ Gramatowski, Rebernik, 2001, 112, 136.

6.7 Vacuum of Baron Zois

6.7.1 Introduction

A little less than 1.5 million inhabitants of the Illyrian provinces cut off the Habsburg monarchy from the sea with the continental barrier-blockade against England as well as for the French *trade* route to Turkey. "The natural" borders with the Kingdom of Italy were pulled down on the Soča (Isonzo) River, and the Illyrian provinces were directly subordinated to Paris, where Napoleon was preparing the abolition of feudalism of the just invented "Illyrians" which failed to succeed in all its might because of the premature Napoleonic Russian adventures.¹¹³⁹

The education in schools and beyond them is the sole salty benefit of every nation. During their four years of existence, Napoleonic Illyrian provinces brought about a dramatic change in the teaching and knowledge of the western part of the Slovene settlement, including Parisian novelties of vacuum technique. What kind of newness were the Slovenian nicknamed Illyrians getting into, and how many innovations in the field of vacuum technology survived the restoration?

6.7.2 *The End of Jesuit Dominance in the Ljubljana Vacuum Survey*

The first contacts of Slovenes with the French Revolutionary armies (1797, 1805, 1809) coincided with the cessation of the dominant influence of the Jesuits on Ljubljana's mathematically oriented education. In the years 1802 and 1803, the death and emigration of the former Jesuits the physicist Jernej (Bartolomej) Schaller and the mathematician Anton Gruber, the younger brother of the more famous Gabriel, terminated the Jesuitical lecturing in Ljubljana's Lyceum. They were the very last succession of once mighty Jesuitical pedagogical enterprise. On the one hand, the flag of knowledge was taken over by the Jesuit disciples, raised in the spirit of Bošković's physics: G. Gruber's pupil Jožef Marija Šemerl and Jurij Vega, G. Gruber's and Jožef von Maffei's private student baron Žiga Zois, Schaller

and A. Gruber's pupil Janez Baptist Kersnik, A. Gruber's friend and opponent of Napoleon Jožef Kalasanc Baron Erberg, the Moravian immigrants professors Neumann and Hummel... Rarely prominent mathematically colored knowledge came out of the Jesuit's countertraditions in Scotus' opus. Among those eminent Scotus' followers was Kastul Weibl's (Caztallus Waibl, at the baptism Janez, * 28. 4. 1741 Novo mesto, 1756/57 OFM Novo mesto; † 25. 10. 1805) Franciscan pupil Valentin Vodnik, who designed Slovenian scientific terminology under the influence of Zois.

An essential novelty flooded in the Slovene and inner-Austrian natural sciences. After the violent demolition of the Protestant scientific bridge between the Tübingen University and Slovenian countries they were mainly infused with Jesuit ideas for over two centuries. Now they benefitted from the Napoleonic influx of non-native lay people who were well-versed in the modern discoveries of vacuum technique. Before the French occupation, such birds were quite rare in Carniola; among them, Balthasar Hacquet in Idrija and Ljubljana became a great local star. At the end of the Jesuit monopoly, after the termination of the lessons of the two former Jesuits, Schaller and A. Gruber, a relatively open competition of qualified Central European rivals for chairs on the Ljubljana Lyceum was enabled. In the first years after the end of Schaller and A. Gruber's lectures, there was no special demand; therefore, the mathematical and physical chair was filled in provisionally, and thus greatly lowered the level of instruction at the then already a century-old Ljubljana philosophical studies. At first, Napoleon's authority did not have a better choice over Kersnik, who became the leading teacher of natural science subjects. Kersnik had finished no other than the Ljubljana schools. Despite of the lack of education, and thus boasting a somewhat lower scientific level of instruction, Kersnik proved to be the most useful learning power, starting with precise French inventories of the cabinet of physics in 1811 with vacuum teaching aids included, through the geometric textbook (1830) to the benevolent fatherly teachings of physics by promoting Slovenian language responses of his benevolent students.

¹¹³⁹ Šumrada, 2007, 76-78.

6.7.3 *Vacuum Technique of Illyrian Provinces at Central Schools in Ljubljana (1809-1813)*

In the first half of the nineteenth century, the Laplacian Parisian School developed an analysis and differential equations, mainly for physics and vacuum engineering, related to new steam engines. The lyceum of Ljubljana purchased even the Laplacian A philosophical essay on probabilities which has an internal red marbled paper cover with a hard-to-read pencil note about the allegedly original owner under his calculating exercises. On the last inner cover, there was a German advertising for sale of paper. The Ljubljana, Gorizian and Trieste mathematicians or physicists were fortunate enough to have come under the direct influence of the more advanced French colleagues during the Illyrian provinces, and thus, they could receive instructions about the numerous new discoveries. Schools in the Illyrian Provinces were organized according to the French revolutionary example of *Écoles Centrales* from the Jacobine era. The professors of the Illyrian provinces were much less impressed by the differently organized example of the *École Polytechnique* established in 1795 and the *École Normale Supérieure*.

The Parisian high schools were publishing even their own scientific journals, from a birds-view looking like the lesser-known later secondary school *Izvestje* (*Programm, Jahrsberichte*) in the lands of the former Holy Roman Empire of German nationality. Some members of the Parisian Academy were willing to avoid longer delays in publishing in academic journals by disclosing their discoveries in the *Journal de l'École Polytechnique* or in the *Journal of the Normale Supérieure*. Unfortunately, the successful usable mathematics of the Laplacian school gathered around the "academy" d'Arcueil in the suburbs of Paris caused the lagging behind the Parisian mathematicians after Cauchy passed away, except for Cauchy's student Hermite and the half-brother of the French President of the Republic, Poincaré. The same thing happened to the Englishman, who were too overwhelmingly committed to Newton's genius, and stayed behind the development of the continental mathematics of Leibniz and Bernoulli. But these are later, pre-March stories.



Figure 6-218:Maximal-minimal thermometer and Papin's Pressure cooker with a pump at Koper Grammar school.

In the years 1809-1813, in Napoleon's Illyrian provinces, the higher studies of philosophy, medicine, and related sciences were fully upgraded only in Ljubljana. Even though the Gorizia folks had even slightly older philosophical studies, their schools did not get such promotions as their Ljubljana rival. Between 1785-1788 Joseph II abolished the philosophical studies in Ljubljana to free up the brain-drain of future Carniolan scholars to the larger Bohemian and Austrian provincial scientific centers. Napoleon developed higher

studies in Ljubljana between 1810-1813, to prevent such an outflow of the local erudite. In the Habsburgian monarchy, Lycée of Ljubljana caused inconvenience, since at the time of the centralization of the state administration at the end of the 18th century, Emperor Joseph could not suppress enough all liberal free-flowing streams in remote schools when they were no longer guided by the Jesuit order after 1773. Napoleon, of course, had no longer problems like that.



Figure 6-219: Steam engine and barometer with siphon at Koper Grammar school.

The Frenchmen established university studies in the center of the Illyrian provinces of Ljubljana in accordance with the school policy of their empire. Interestingly, Napoleon's official did not easily find professors of mathematics and chemistry among the domestic lecturers. It seems that in the natural science fields focusing the study of the vacuum technologies there was the most powerful outflow of educators into the more scientifically developed Habsburg schools, although from there,

namely from the golden Prague, Napoleonic Ljubljana received excellent mathematician Gunz.

The three years of the existence of high schools in Ljubljana as the central educational institutions of the Illyrian Provinces certainly encouraged the later demands of the University of Ljubljana. After the March Revolution, the dream of the domestic university became the common message of educators from lands inhabited by Slovenes. In a short interval of time of the Illyrian provinces, with the probable exception of Gunz or Ž. Zois Ljubljana residents did not attribute significant scientific achievements, since education in the Illyrian provinces was constantly in the middle of financial turmoil.

In 1810/11, in two-year and three-year (Ljubljana) gymnasiums of the Illyrian provinces nobody taught physics or science. Also, on colleges between 1811-1813 and on a five-year Lyceum in Ljubljana there was no lesson in science. In the middle school stage, they taught physics inside the natural sciences only in 1810/11 at the lyceums of Trieste (astronomy), Koper and Gorizia.

In 1810/11 in the part of the Illyrian provinces inhabited by Slovenes, only Kersnik lectured on physics in the first years of all five faculties of the Central School in Ljubljana. Kersnik followed Neumann's textbook published in the Latin language; Neumann was Kersnik's teacher and predecessor in the same department in Ljubljana, so the choice of his textbook was quite inevitable. Twenty-seven years old Neumann from Moravia became a professor of the Ljubljana grammar school on 21 July 1801 and stayed there until his departure from Ljubljana. In addition to his classes in grammar school, on February 16, 1802 he became a teacher for Greek language. On 3 May 1803 he replaced the diseased Schaller and became the first full professor of physics who was never Jesuit in Ljubljana's Lyceum on October 31, 1803. On 12 September 1806, Neumann together with the director of the Ljubljana Philosophical Studies, F. Wilde, signed a certificate of the Greek Philology exam for the student Jurij Paušek.

In autumn 1806, Neumann left Ljubljana for the University of Graz, where he taught astronomy at Joanneum since 1812. Unlike Ambschell before him, he first published a Latin language physics textbook in Graz between 1808 and 1812. His

textbook was translated into German a decade later. He published the translation in Graz and dedicated it to the imperial personal physician Andreas Josef baron Stifft (1760-Röschitz in Lower Austria-1836 Vienna). He dedicated his song to his director at the Viennese Polytechnic, Prechtl.¹¹⁴⁰

The first part of Neumann's German translation comprised 560 pages in 522 chapters, and at the end, he added twelve tables of copperplates with 270 small images. The longer second part of the textbook has 722 pages. On pages 723-783, he put out a table of contents for both books, although each of them already had tables of contents at their beginning. He has published fifteen copper plates, with a total of 372 images, on five pages including the list of errors. It was almost genuine for the eyes of diligent students. On the penultimate figure 371, six different shapes of snowflakes were drawn in the spirit of the then emerging mineralogy, which Gruber and Hacquet also helped to develop. The Latin NUK edition of Neumann's textbook is lost today, and the German translation was once Zois's with a reinforced leather back of cardboard covers, triangular leather edges of covers and red marble inner covers.

Neumann has drawn a comet (tab III), Tycho's system (tab IV, fig 47), a very fortunate illustration of a vacuum pump,¹¹⁴¹ a Leyden jar as an accumulator of electricity (tab VIII, fig 171), capillary (tab IX, X), and crystalline forms (tab XI, XII). The sketches in the second book were dedicated to sound (tab I, II), a telescope with a micrometer to measure the rotation of the polarization plane (tab III), the steam engine (tab V), the eye (tab VI), the geometrical optics (tab VII), the bipolar crystal (tab IX), refraction and eye (tab X), microscope (tab XI), Leyden jar (tab XII), vacuum pumps, rainbows and snowflakes. Among the Latin language textbooks, at the beginning of the second volume, he recommended Newton's *Principles*, 'sGravesande, Ch. Wolff, Musschenbroek's *Institutiones* (1748) or *Introductio ad philosophiam* (1762),¹¹⁴² but not Bošković, although Neumann described Bošković's dynamic theory of point-contact bodies

as the last word of the dynamics and therefore most relevant.¹¹⁴³

Among the new German textbooks printed after 1790, Neumann praised Imhoff's manual, which was also used by the Franciscans of Novo Mesto (New City). Among the new Latin textbooks, Neumann also boasted his own, Ambschell and Döttler's work.¹¹⁴⁴ Among foreign editions, Neumann also recommended Biot, Cavallo, Th. Young, Playfair and Giuseppe Saverio Poli whom Zois also read. Among the encyclopaedias Neumann liked to examine Gehler's work, but among the journals and newsletters of scientific societies Neumann acknowledged almost everything. Among physicists he praised Fischer and Gilbert,¹¹⁴⁵ and among the specialized works Neumann favoured Priestley's optics and electricity, Pfaff, Bohenberg and Brandes's book issued in 1820. Neumann was interested in Beccaria's experiments with phosphorescence of animals and plants,¹¹⁴⁶ as well as Bologna stone and John Canton's phosphorus.¹¹⁴⁷ He presented Newton's emanation theory of light and the opposite Euler vibrational system, as well as the dynamic variants of the vibration system of Huygens and Descartes,¹¹⁴⁸ but Neumann did not say which version he was supporting. He was interested in a photometer¹¹⁴⁹ besides the Newtonian colors on a prism,¹¹⁵⁰ but he also pushed forward Goethe's criticism of mainstream Newtonian optics.¹¹⁵¹

In 1842 Neumann reprinted the first part of his textbook. In 1815 Neumann left Graz and from 1816 until retirement in 1844 he was a physicist and secretary of the Polytechnic in Vienna. Today, near the Polytechnic, Neumann's memorial plaque is built under the bell tower next to the church. In 1819, in the first yearly volume of the Polytechnic Institute News, Neumann published a paper about Abraham-Louis Breguet's bimetallic strip thermometer.¹¹⁵² Breguet was a watchmaker in

¹¹⁴³ Neumann, 1820, 1: 27.

¹¹⁴⁴ Neumann, 1820, 2: IX.

¹¹⁴⁵ Neumann, 1820, 2: X, XI, XIII.

¹¹⁴⁶ Neumann, 1820, 2: 205.

¹¹⁴⁷ Neumann, 1820, 2: 206.

¹¹⁴⁸ Neumann, 1820, 2: 207-209.

¹¹⁴⁹ Neumann, 1820, 2: 218.

¹¹⁵⁰ Neumann, 1820, 2: 218.

¹¹⁵¹ Neumann, 1820, 2: 324.

¹¹⁵² Ciperle, Ljubljanska gimnazija, 119; Poggenдорff, *Biographisch-Literarisches*, 2: 274-275.

¹¹⁴⁰ Neumann, 1820, 1: XIII.

¹¹⁴¹ Neumann, 1820, 1: tab VIII, fig. 164.

¹¹⁴² Neumann, 1820, 2: tab XIII, fig. 298, 323; tab XV, fig. 357 and 371 in table VII.

6.7.4 *The Jew Gunz - Ljubljana Brightest Scientific Star*

Paris, a member of the Parisian Academy and of a length bureau. He left the position to his nephew who was also a famous watchman, while in his free time he measured the speed of light and sound in various substances.

The older Breguet did not only learn how to make clocks; two years before Neumann's discussion he published research on temperature measurements by observing the stretching of the metal. Breguet used a tension spring that extended during heating. He placed the needle on the bottom for reading the temperature, but of course he set the scale empirically. He collaborated with his forty years younger fellow watchmaker-watch-dealer Jean Charles Athanase Peltier (1785 Ham-1845 Paris) who researched the thermoelectric currents for Seebeck's thermocouple. In the late 19th century Breguet's thermometer was used in schools. In 1900, nearly a century after Neumann's description, James W. Queen & Co. from Philadelphia sold Breguet thermometers for \$ 25.

Besides Breguet's merits, Neumann also attributed the invention of metal thermometers to Samuel Christian Hollmann (* 3. 10. 1696 Stettin; † 4. 9. 1787 Göttingen), a full-time professor of philosophy at the University of Göttingen and director of a local scientific society. Hollmann was, of course, mainly concerned with barometers, but he also liked thermometers.

After moving to Graz, Neumann published a textbook *Compendia physica institute* in three parts in 1808-1812. Neumann's student Kersnik acquired Neumann's Graz textbook in Ljubljana immediately after printout. Under number 17, it was recorded in the Supplementum (additions) of the Wilde's list of the Lyceum Library of Ljubljana in 1789-1809.

Between 1811-1813, the Academy of Ljubljana had a special one-year philosophical faculty. There Kersnik lectured on physics in French language to the seventy-two students, and next year to seventy students. In 1812/13, some students of philosophy also passed exams from cosmography which combined some astronomical approaches.

After Jenko's resignation and short Kersnik's replacement the new French school authorities entrusted the Chair of Mathematics to Jenko's friend, Samuel Gunz (Leopold Gientz, Guentz, * 1782/85 Prague). Because of the war shortages, the perspectives of the Ljubljana newly established educational chairs did not really flourish before the Napoleonic occupation, which suddenly woke Ljubljana from a centuries-old sleep as the seat of the Illyrian Provinces and a center of education with its university. The educated professors, such as Zelli and Gunz, were attracted by the French scholarly novelty into the sleeping Ljubljana. Gunz was the professor of basic (elementary) and applied mathematics from the autumn of 1810 until the year 1819.¹¹⁵³ Occasionally, Gunz's assistant was employed to teach the basics mathematics. Gunz arrived in Ljubljana from the mathematical department in Gorizia; there he also left his mark, which was later upgraded by the slightly younger Močnik and A. Cauchy on mathematical basis. Between 1812-1813, the mayor of Gorizia was Francis Janez Neri de Maffei (* 23 November 1738 Vipava; † 8 January 1826 Duomo in Gorizia), brother of the former Ljubljana professor of mathematics and Zois's private teacher, Joseph Jakob Liberatus Maffei de Glattfort.

Charles Nodier twice mentioned Gunz when listing well-established Illyrian scientists. For the first time, he wrote his surname as Günz on February 1, 1815 in an article for the *Journal des Débats*, and secondly as Gienz in the article entitled *Laybach*, published in *La Quotidienne* on 15 January 1821; Gunz's membership in the Carniolan Agricultural Society, the interest in the Slovene language with its grammar included, the enthusiasm of poetry and natural science were highlighted in both publications. Nodier praised Gunz as a lexicographer and a grammar expert without mentioning his professorship of mathematics, which seemed to be strange, as if Nodier was narrating about another guy. In his articles, Nodier used Hacquet's ethnographic work in Breton's French translation, and among the meritorious "Illyrian" scientists, Nodier listed Bošković,

¹¹⁵³ ZAL, SI_LJU 184, Accessory fond 1., Technical unit (Tehniška enota) 53.

Bošković's friend Benedikt Stay, Raymond Cunich, Brno (Bernardo) Zamagna who published the Latin verses about the Jesuit vacuum balloons of Lana Terzi from Brescia, and other Dubrovnik natives with Dalmatians included.¹¹⁵⁴

Samuel Gunz was the son of Rabbi Simon Gunz, a teacher of mathematics, measuring of bodies, commercial computing and German reading in the Israelite high school in Prague (Israelitische Deutsche Hauptschule Prag, Hauptschule der prager Israelitengemeinde) which worked in 1782-1850. Simon Gunz taught there at Jüdisch-deutschen Schulanstalt in Prague in 1782-1817, while his wife Anna taught girls the female domestic works at the same school in 1782-1813.¹¹⁵⁵

Simon Gunz published textbook *Theoretisch-praktisches Rechenbuch für Lehrende und Lernende* dedicated to the count Henry Frances Rottenhann in Prague in 1802. The count Henry Frances Rottenhan (1738-1809) was the highest Prague burgrave who served as administrative lawyer, president of the supreme court of justice and court commissioner for legislation in Bohemia and Austria. The textbook was reprinted six times in Prague in 1808-1832. In 1809 and 1821, Simon Gunz published the updated instruction of Johan Christian Nelkenbrecher († 1760) for the exchanges of different European money, weights and measures into the Viennese units. So, Samuel Gunz learned the secrets of numbers already in his native Prague house. He passed his (applied) mathematical exam including the final mixed queries about vacuum pump (no. 236) and barometer (no. 237) published on page 50 among 247 exam questions in a public examination. He was then a graduate student of second year of philosophy in the class of Stanislas Vydra (Wydra, 1741-1804) in Prague university on July 27, 1802. The situation in Carniola was known to the Prague native Gunz by the narration of Tobias Gruber, the

brother of the professors of Gabrijel and Anton of Ljubljana, who was close to Gunz during their Prague mathematical and physical research.

In 1809/10 Samuel Gunz started teaching at the Ljubljana Academy for nine students of mathematics in the second year of the French Central Schools in Ljubljana. The Ljubljana French college had about 300 students in its first year of existence. The freshmen were on average eighteen to nineteen years old, which was around a year more than elsewhere in Europe. The reason may not only be the lack of knowledge of Carniolan boys, but especially the disorder of the continuing schools during those difficult hardest war times.

According to the rulebook, signed on 1 August 1810 by the former candidate for the Ljubljana professor of mathematics and then the director of the lyceum in Zadar public health inspector Rafael Zelli, the future doctors, surgeons, pharmacists, theologians and lawyers in Ljubljana did not study mathematics. The engineers and architects attended mathematical lectures in the second, third and during their last fourth year of studies.

In 1810/11, Gunz taught theoretical mathematics and practical geometry to five students of the first year and to eight second year students of the Faculty of engineers and architects. He lectured in Latin language. In 1811/12, mathematics was taught in the third and fourth class, where the teaching was taken over by Kalister who used the previous Habsburg textbook. In the fifth year, Gunz interpreted optional mathematics lectures to only five out of seventy students; he used his own notes, most likely those he published several years later in his book. Thus, Kalister and Gunz shared mathematical curricula according to the ancient practices; Kalister explained introductory chapters, and Gunz taught higher mathematics, which was no longer limited to astronomy.

In 1811/12, Gunz instructed his students as the future engineers and architects about the secrets of transcendental and "special" mathematics. He trained nine (sic!) students of mathematics from last year's second class about trigonometry. He taught them the algebra in geometry, differential and integral calculus. Gunz even assessed his students' behavior, which, of course, is a bit unusual for a modern university. However, at those

¹¹⁵⁴ Dahan, 2006, 267, 272, 274-275; Maixner, 1960, 26, 37, 65, 66, 103, 105. On 13th December 1779 Zois even helped the Viennese acquisitions of books for his former teacher Maffei (Svoljšak, Vidmar, 2019, 27).

¹¹⁵⁵ Britta L. Behm, Uta Lohmann, Ingrid Lohmann. 2002. *Jüdische Erziehung und aufklärerische Schulreform*. Münster/New York/München/Berlin: Waxmann, p 247; Královská česká společnost nauk, *Kaiserlich Königlicher Schematismus für das Königreich Böhmen auf das Jahr...*, Prague: Jan Nepomuk Ferdinand Schönfeld, 1795: 206, 1813: 53.

different times all exemplary behaviours were perhaps the result of politically "correct" beliefs. Gunz's students would be able to graduate next year, but Gunz then ceased lecturing. On 13 July 1813 he had mathematics exams, but they were not mandatory. Gunz's students wanted to continue their studies at the Polytechnic in Paris; unfortunately, Napoleonic battles in the burning Moscow almost buried their dreams about the Elysian Fields. The new / old Habsburgian rulers preferred Viennese educations of Guns' students, although they had to "leave the belly outside" because of the high prices in the capital on the banks of the Danube. Among Gunz's students, Čop, Jovan Vesel Koseski and France Prešeren¹¹⁵⁶ proved themselves. Gunz as a benevolent teacher later assisted with the services and with his Viennese recommendations in favor of both Čop and Koseski. Gunz recommended Koseski to the Viennese professor of Kantian theoretical and practical philosophy Leopold Rembold in 1818. Among Rembold's student was also the baron magnate Simon Georg Sina (1810-1876). If Gunz really liked poetry so much as Nodier claimed, Gunz might have been also nice teacher to the future leading poet France Prešeren as Gunz also attended Franc Metelko's Slavistics lectures in Ljubljana Lyceum as a member of Carniolan agricultural society.

In 1815 Gunz published a book on parallel movements used in the theories of Swiss Euler's student Louise Bertrand (1731–1812)¹¹⁵⁷ and Johannes Schulz (* 1739) with the mention of Schenkel. At Calvin Academy in Geneva Bertrand arranged Euler's discoveries for trigonometry; with his many books, he influenced Lacroix, and in paragraphs of geometry, he also described the history of geometry. After Napoleon's first downfall in December 1814, Gunz dedicated his work of sixty-two pages with two sketches to his "dear friend" Gunz's Ljubljana's predecessor Jenko, then a professor of mathematics and technology at Joanneum in Graz. The introduction to the book was signed in December 1814 as soon as Gunz accepted the Catholic faith. In those times Napoleon was residing on Elba after 4 May 1814, but in Europe the weapons would roam around

again during Napoleon's 100 days between March 20, 1815 and Waterloo of 18. 6. 1815. Gunz divided his book into pure mathematics with the basics of parallel lines theory¹¹⁵⁸ and technical mathematics with the description of city bells in the towers.¹¹⁵⁹ Gunz painted two pages full of pictures: the first with parallels, the second with sawed broken lines.

Gunz urgently recalled the problems of the theory of parallels,¹¹⁶⁰ which really led to the non-Euclidean geometry of the Russian Lobachevsky and the Magyar Bolyai few years later. In the second addition he described Legendre's theory,¹¹⁶¹ in the third Bertrand's derivation of the Legendre's *Éléments de Géométrie* (1810)¹¹⁶² and in the fourth Schulz theory;¹¹⁶³ Schulz also published the foundations of an infinitesimal calculus. In the end, Gunz added J.P. Neumann's description of the sundials (Gnomons) in the towers depicting the artworks of Joseph Geist (1770 Vienna-1824 Graz) and astronomical pendulum clocks. As the leading specialist for pendulum watches, Joseph Geist and his relatives established the first Habsburgian fabric of clocks in 1819.

The first non-Jesuit professor of physics in Ljubljana, Neumann, was a professor of physics at Graz at the time, and Gunz was obviously in close contact with him as well as with Jenko. Neumann was indeed co-author of Gunz's book on parallels, as Neumann independently signed it at the end of his paper on pages 59-66.

In view of his study of the recently issued Parisian researches, Gunz's book was very modern. He finished it with two tables; in each he drew six simple geometric sketches that he referred to in the text. Gunz's book came to the Lyceum library with the purchase of Zois' Book Treasures along with Neumann's Latin textbook,¹¹⁶⁴ which shows the obvious connection between those Ljubljana's peers.

In Ljubljana, Gunz lectured in Latin language. He used the textbooks by Sylvester François Lacroix (* 1765; † 1843) on an infinitesimal calculus;

¹¹⁵⁸ Gunz, 1815, 1-58.

¹¹⁵⁹ Gunz, 1815, 59-60.

¹¹⁶⁰ Gunz, 1815, 20.

¹¹⁶¹ Gunz, 1815, 33.

¹¹⁶² Gunz, 1815, 47.

¹¹⁶³ Gunz, 1815, 55-58.

¹¹⁶⁴ *Compendiaria Physica*. Graecii: Ferstl (NUK-8215).

¹¹⁵⁶ Dahan, 2006, 271.

¹¹⁵⁷ Mistakenly noted by the name of count Henri Gatién Bertrand (1773-1844), the general governor of Illyrian provinces from April 1811 up to 1812 (Dahan, 2006, 272).

therefore, for the needs of his lesson in Ljubljana, Gunz acquired Lacroix's textbook of mathematics. Both books are not noted in F. Wilde's catalogue, nor in the Zois' list of books; they obviously got them later in Ljubljana Lyceum. The first edition of the Differential and Integral Calculus of Lacroix was printed in 1797 in two parts. It became a textbook of École Polytechnique, used for generations. The second edition was printed in 1806 when the English translation was also published. From 1788 to 1793 Lacroix lectured at the artillery school in Besançon in eastern France, where he befriended Nodier's mentor Giordo de Chantrans. Lacroix introduced the term "analytical geometry." At the times of the Illyrian provinces he lectured at Sorbonne. In 1799 he became a member of the Institute; he achieved his best in probability theory and mathematical analysis; and above all he proved himself with many successful textbooks.

After Napoleon's defeat, the expatriate Jew Gunz expected problems in white Ljubljana. To help him, the mathematics professor A. Wolf (Volf), was also employed at the restored Lyceum instead of Kalister. On 11 September 1814, Gunz was baptized as Leopold in the Ljubljana cathedral, "Sentklavž". Without the Christian faith, he felt a little marginalized in the high society of Carniola, and therefore the transition to the Catholic Church seemed to him to be very promising, but he also had to lead his own religious inclination. At last in those times after restoration Gunz openly opposed the so-called enlightenment and nursed some ties with the Viennese university professors of theology. He converted just few weeks before he signed the dedication into his new book to be published by Miller in Graz which probably gained the prestige with Gunz's conversion. He planned the transition accurately enough as an important social event. The ceremony was led by V. Vodnik's friend the retired vicar of Ljubljana cathedral Jurij Miklavčič (Miklautschitsch, 1756 Zali log in Upper Carniola-1829 Ljubljana) with the general interest of the faithful from close and far. Gunz's godfathers were a professor of church law and history of the church in Ljubljana Jurij (Georg) Dolinar (* April 19, 1764 Vovče in Poljane valley; † 21. 10. 1858 Ljubljana) and councilor of the regional court Anton Gogala (* about 1789 Lesce by Bled; 1835 von Leesthal; † 9. 10. 1841 Trieste). The District Commissioner Hensberg in Styria, Gogala, volunteered to fight

against the French as a captain of the Home Guards (Brambovci). Nevertheless, he became the judge of the tribunal of the first instance of the Illyrian Provinces. Gogala's older brother, Józef Balant (Walland, * 28. 1. 1763 Nova vas near Radovljica; 8. 3. 1818 Gorizia Bishop; 3. 8. 1830 Gorizia Archbishop; † 11. 5. 1834), served the French as director of the Academy in Ljubljana; he was one of the most influential ecclesiastical people and certainly an important guy on the balance of Gunz's conversion. The Graz student Dolinar was a student of physics in the class of a former professor of Ljubljana Leopold Biwald. Between 1810 and 1813 in Ljubljana the professor Dolinar taught Roman law and Code Napoléon.¹¹⁶⁵

The baptized Gunz was a provisional professor of mathematics in the renewed Ljubljana Lyceum in 1814 and 1815, after which he took over the chair as a full professor. In 1819, he left the white Ljubljana and became a professor of higher mathematics on a Lyceum (Akademische Gymnasium) in Linz where Boltzmann studied in 1855-1863. In 1824, the professor of applied mathematics, physics and Natural History in Lyceum of Linz was Adam Mathias Chmel (1770 Teschen-1832 Linz) who taught there from 1803, and the professor of pure mathematics and Greek language was the Cistercian Johan Baptist Schober (1783 Oberweißenbach-1850 castle Mühlendorf, Feldkirchen a.d. Donau) who taught mathematics there from 1807. Therefore, Gunz might have taught in Linz just as a replacement for Schober who toured Naples and Switzerland in 1818, but Gunz was never noted in official registers or the Lyceum of Linz nor anywhere else in Habsburgian monarchy after the school year 1818/19. Leopold Gunz's affairs in Linz might be misinterpretations in SBL, as he ceased to be a member of Carniolan Agricultural society in 1819. He might have visited his elderly father in Prague if his father the rabbi was not to uncomfortable with his recently converted son. Most probably, Leopold Gunz left Habsburgian monarchy, or he died. The chairs for mathematics and physics were vacant in Linz Lyceum in 1830-1833.¹¹⁶⁶ Gunz's eventual

¹¹⁶⁵ Glonar, 1925, 142.

¹¹⁶⁶ Benedict Pillwein, *Beschreibung der Provinzial-Hauptstadt Linz und ihrer nächsten Umgebung, mit der ältesten Geschichte und mit einem Umriss des Erzherzogthums Oesterreich ob der Enns als Einleitung; von Benedikt Pillwein, k. k. Provinzial-Staats-Buchhaltungs-Ingrossisten zu Linz; Mit der Karte des Kommissariats.* 1824, 219-222; *Hof- und Staat...*, Wien, 1808, 1817: 201, 1819:

position in Linz was not higher than in Ljubljana, although the city itself was more important. Gunz's departure had to be sufficiently unexpected for the school authorities in Ljubljana, as Gunz was only temporarily replaced by Kersnik for a long time.

6.7.5 *Kersnik and Zois's Model of Vacuum Blast-furnace*

Janez Krstnik Kersnik (* March 26, 1783, Moste pri Žirovnici in Upper Carniola (Gorenjska); † 24 June 1850 Ljubljana) first lectured on physics at the fully established University of Ljubljana's higher studies. The wealthy father brought him up with the income of his farm, mill and sawmill. Janez Kersnik's grandson was the writer Janko Kersnik.



Figure 6-220: Kersnik portrait (Kersnik's great-granddaughter's gift)

Kersnik had a good command of French language, which at that time was a great advantage for a professor in the Illyrian Provinces. In 1809/10, he lectured in French language at Central schools in Ljubljana, and in 1811 he listed experimental devices in the cabinet of chemistry and physics of the Central schools in the French language with some minor spelling mistakes. The list shows that Kersnik really had something to show to his students, as he did not miss the latest teaching aids. As the first device in the chemical cabinet, he listed a vertical pneumatic device or a vacuum pump, and the second one was Ž. Zois invention of blast furnace and associated movable supports. It seems that Zois used the recent the development of

a vacuum steam engine to design a model for Kersnik's demonstrations to technically talented students in his Ljubljana School. Kersnik had two other bellows with a board and lamps, two thermometers with metallic measuring scale, a balance with weights made of brass, a smaller and larger scales, a battery with a voltaic cell, two aerometers, a large bellow with a long copper tube, a copper pneumatic tub (for vacuum experiments) and a silver lantern with all needed supports. In the Hydrostatics Department, the conscientious Kersnik kept two tubes connected to the third in communicating vessels, a hollow cylinder of glass and brass. Together with them, he placed a partially framed truncated cone, an elongated gilded vase, a Viennese volumetric measure made of brass, a double fountain, a cubic inch as a hollow measure, a collection of all simple hydrostatic devices, several glass bells. For vacuum experiments, he collected an opened glassy hollow ball, a Magdeburg hemisphere for proof of the vacuum, a hollow copper opening, three very small valves, three medium sized cylinders for the research of vacuum with a pump, Heron's water pump with a rotary jet, a pneumatic device (a vacuum pump resembling the one listed above), a barometer, an intermittent fountain consisting of a cylindric glass tube with its upper end pear shaped which penetrates to its full length to the bottom of a tray, a double fountain and a Cartesian diver containing a weight more dense than water and an air bubble less dense than water. When the container is squeezed, the internal air pressure increases, and the size of the bubble decreases. As a result, the density of the diver changes from being less dense than water to being denser than water and the diver sinks. It was acquired already by B.F. Erberg for the Jesuits of Ljubljana in 1755.

Kersnik greatly improved his collection in 1811 when he acquired the portable Volta's zinc-gold battery, the optic observation of the floating feather, the hygrometer with a thermometer and a pneumatic lighter which was probably a Voltaic pistol. Early in the same year, the general governor of the Illyrian Provinces, the Duke of Dubrovnik Marshal Auguste-Frédéric-Louis Viesse de Marmont (* 1774; † 1852) donated his extensive laboratory to Kersnik's cabinet of the Ljubljana Central Schools. The gift included a detailed analytical balance and Volta's battery at a voltage of 100 V (perhaps the one which Kersnik listed), a

154, 1820: 155, 1821: 164, 1827: 159, 1830: 152, 1832: 153, 1833: 251, 1834: 153

galvanic battery with hundreds of elements of copper zinc, a distillation apparatus, a gasometer, an audiometer, an annealing furnace, high temperature gas heaters, fourteen retorts, twelve bottles of Irish chemist, alchemist and mineralogist Peter Woulfe FRS (1727–1803) as an apparatus for purifying or dissolving gases, which employed a bottle with two or three necks designed ca. 1767, nineteen funnels, two muffle furnaces (oven, retort furnace, fourteen containers, thermometers, aerometers, glass, metal and porcelain pipes, several hundred laboratory flasks, two hundred glasses, porcelain cooking pots, iron and wooden stands, tweezers and spoons.¹¹⁶⁷ Marmont obviously learned a lot from his private chemistry teacher, Zelli; Marmont certainly liked to get some buzz at home. On 16 November 1809, Marmont arrived in Ljubljana Bishop's house as General Governor of the Illyrian Province, and he returned to Paris at the beginning of 1811.¹¹⁶⁸



Figure 6-221: Present of Kersnik's students for his name day (Janez Šumrada's gift)

6.7.6 *Science Outside the Center of the Illyrian Provinces in Novo mesto, Gorizia, Trieste, Koper, Zadar*

Ljubljana was never so important as during its capital role Illyrian provinces. The other cities of Illyrian provinces also profited from those sudden changes, despite of heavy military burdens. The priest and their religious orders suffered a lot, but the lay erudite got their chance. Weibl's student,

the Franciscan Valentin Vodnik, indebted Slovenians more than any other St. Francis's heir. Among other scientific works, he accomplished some telescopic observations with Zois's support. The Napoleonic government changes at Zois' science and Kersnik's education enabled French revolutionary novelties. They upgraded the last traces of the Jesuit's centennial education of physics and mathematics at Ljubljana higher philosophical studies with Gunz, Kersnik, and their supervisor, Zelli. The relations between the leading literati of those days Ljubljana included Nodier, Marmont, Knauer, Vodnik, and Ž. Zois. The chief Napoleonic antagonists were Rijeka based Brits consul John Leard (Laird, 1760-8. 10. 1843) and general Laval Nugent.

The French invaders organized the studies in the Illyrian Provinces as they did in the Parisian revolutionary Jacobin *Écoles Centrales*. The Frenchmen established the Illyrian Provinces metropolitan Ljubljana University to prevent "Illyrian" brain drain to the Habsburg Empire. Napoleon's administrators had the hard time to get the useful professors for chemistry and related subjects because the domestic experts were considered insufficient. The other Illyrian Province schools in Gorizia (Gorica), Trieste, Koper, Rijeka, and Zadar were no longer mastered by religious orders under the Napoleon's rule. The destiny of Napoleon's scientific ancestry at Slovenian lands provides the surprising conclusion that the Restoration brought almost no changes, because the Ljubljana professors of sciences kept their chairs also under Metternich's regime to support the poetical thoughts of Gunz' student, Jovan Vesel Koseski: »The changes are only damages, just few of them remains«.

Zois' circle is the key for understanding of the Illyrian provinces literati of Napoleon's era. Zois' collection of minerals was comparable to with the Kersnik's one at Lyceum. Vodnik's collaboration with Zois was reflected at Zois' literature on numismatics, and even in his Serbian and other mathematical textbooks for the beginners, which helped Zois and Vodnik on their invention of the Slovene mathematical terms. Zois published one of the most important early scientific description of Proteus. He used his home library as the source for his experiments and observations, and he also studied many modern scientific journals he ordered around Europe. Baron Žiga Zois learned his mathematical sciences during his private lessons

¹¹⁶⁷ Zelli, 1811; Jozelj, 1992, 43.

¹¹⁶⁸ Boudon, 2006, 226, 231.

with Gabrijel Gruber and Gruber's assistant Maffei in Ljubljana. Two centuries ago Zois became the most important literati in Ljubljana.

6.7.7 *Capuchins and Franciscans in French Ljubljana and Gorizia*

Napoleon's era was not written on the skin of Franciscans. In 1809, the French disbanded the Capuchin monastery of Ljubljana by the resentment of Marmont's wife, who became angry during the Capuchin's fiery sermon. His not quite crystal-clear handkerchief flew into the bosomed beautiful breasts of Mrs. Marmont. So, she outrageously exclaimed in the middle of the land of savages, so far from the Parisian paintings. In 1817 the monastery was demolished along with the church. However, reports of the further fate of the incriminated handkerchief, despite careful investigations, do not say anything clear for the time being.



Figure 6-222: Lalande's title page (Lalande, 1769;).

About two hundred books from the Ljubljana Capuchin Library went to the Capuchin church of Škofja Loka. Valentin Redeschini De Haidovio Radeschini, * 21. 7. 1746 Ajdovščina, OFM Cap 1765; † 4. 2. 1810 Gorizia), the most important Slovenian capuchin of Napoleon's era, returned came to the "Illyrian" Gorizia in his last days; he described the vacuum on the model of Bošković.

Notwithstanding the above-mentioned handkerchief, on 6 January 1811, the French army of Marshal Marmont expelled the Gorizia Franciscans from the St. Anton of Padua's Monastery to nearby Kostanjevica. Since 1821, they have been developing a gymnasium with a Philosophical school for the teaching of theology, mathematics, physics, philosophy, history and Latin language, which also worked successfully during Cauchy's two-year exploration of optics, ether and vacuum in Gorizia. They started modestly, with two teachers and two students. The first lecturer taught religion, mathematics and physics; the Franciscan certificates were publicly valid and allowed the graduates to teach at gymnasiums, including two of them which were led by the Franciscans in Novo mesto and Kostanjevica. The Kostanjevica Gymnasium was later transferred to Kamnik.

6.7.8 *Zois's Vacuum Science in his Networks Captured by the Armed French Gentleman*

Zois (* 23. 1. 1747 Trieste; † 10. 11. 1819 Ljubljana) was a graduate student at the Seminario-Collegio for laymen or sons of the newly ennobled families who were enrolled at the spiritual seminary Reggio Emilia (October 1761-1765). The institute was founded on 1 November 1750 and abolished in 1790, but later operated under other names.¹¹⁶⁹ In 1763/64 and 1764/65, Žiga studied computing, sciences, architecture, drawing, and basic experimental vacuum techniques. Reggio Emilia had a Jesuit school established in 1618, and since 1752 there has been a university¹¹⁷⁰ where physics and mathematics was taught by Lazzaro Spallanzani (* 12. 1. 1729 Scandiano by Modena; † 11. 2. 1799 Pavia), after his cousin Laura Bassi (* 1711; † 1782) turned him into natural science fan during his studies at the University of Bologna. Spallanzani opposed the spontaneous generation by his experimentally overheated microorganisms; he corresponded with the Swiss biologist Charles Bonnet, whose book Zois had. At Zois College, Spallanzani taught Greek and French language. Žiga's brothers learned those languages.¹¹⁷¹ Žiga did not learn Greek language, but he may have studied French

¹¹⁶⁹ Kacin, 2001, 50, 62.

¹¹⁷⁰ Kacin, 2001, 45.

¹¹⁷¹ Kacin, 2001, 47, 62, 78.

language in Spallanzani's class, although there is no archival data about those facts. In 1769, Spallanzani took over the chair in Pavia,¹¹⁷² and in 1785 he collected natural curious discoveries along the Mediterranean and even in Turkey. Spallanzani has anonymously put an artefact from chicken tissue to semi-blind Scopoli, as if it were the species of still undiscovered nematodes (roundworms); the elderly Scopoli did not notice the hoax and urgently published his new "discovery" in his book. In the year of Scopoli's death, Spallanzani published a letter to Scopoli with the criticism of Volta under the pseudonym Francesco Lombardini. Later, Spallanzani quickly decided to support Galvani's theory of animal electricity in his dispute with Volta,¹¹⁷³ which probably means that he did not support the French revolutionaries whom Galvani or Zois also disliked. In fact, Napoleonic victories promoted Voltaic ideas.



Figure 6-223: Lalande's chapter about his visit to Piran native Tartini, also read by Zois in his collection (Lalande, 1769, 8: 292).

Žiga Zois did not have Spallanzani's works. Žiga Zois developed his naturalistic mentality with his uncle's mother the physician Janez Krstnik Pollini¹¹⁷⁴ in Ljubljana. Zois advocated a Neptunistic theory against JE Fichtel and other volcanists also with evidence from Triglav mountain range provided by Vodnik and F.

¹¹⁷² Agnes, 2006, 8, 54.

¹¹⁷³ Polvani, 1942, 152, 174, 420; Jozelj, 1992, 40-41; Marković, 1969, 639, 756; Šumrada, 2001, 66; Soban, 2004, 48; Z. Bufon, Janez Anton Scopoli, In: SBL (1967), 256; D. Soban, *Johannes A. Scopoli*, Ljubljana 2004, 48.

¹¹⁷⁴ Faganel, 1999, 8, 12.

Hohenwarth after their Triglav expeditions in August and September 1795. During that time Vodnik worked as the parish manager in the Bohinj areas of Koprivnik, observed the geological strata at the Triglav peaks through the binoculars and described his feelings in the Vršič poem in August 1795. In September he accompanied Zois miners to gather fossilized sediments below the very top of Triglav.¹¹⁷⁵ At his home, Zois hosted naturalists Hladnik, Hacquet and Šemerl.¹¹⁷⁶

Zois postponed his common youngster travels, probably due to his father's needs for help. He journeyed only relatively late from early 1779 until the spring of 1780. He visited many places including Switzerland, France and the Walloon part of the Habsburg Netherlands in near the borders of modern Belgium, where the goodwill memory of the deceased empowered minister Ljubljana Count Kobencel still used to be strong. Zois's return was forced by his gout which shew him its teeth in eternal Rome. In 1782, Zois had been unsuccessfully treated for several weeks at the city of Spa, the Belgian spa in the Province of Liège.¹¹⁷⁷ Thus, the baron of Ljubljana was very impressed with the enthusiasm of French natural sciences and the knowledge of the French language before the evil gout thrilled away his joy from everything outside the house. Zois purchased most of his French mathematics, physics and chemistry printed in the first two decades of the revolutionary Paris. Among other things, he also acquired the works of determinedly free-minded naturalists, such as Lalande and mathematician De la Metrie, the namesake of a more notorious older materialistic philosopher.

6.7.9 Zois's Library

Zois' Library with 4000 notebooks was available to a wider circle of Slovenian enlightened writers; the specimens of former Zois' books in NUK or NMLJ are identified by the characteristic marble inner covers with the prevailing red color, brown leather binding and the golden name of the author above the title and flowers on the spine. Those books do not have Zois' proprietary entries, but their shape speaks for itself. Zois has probably designed them for resale at the time of purchase. Names of Zois's librarians are not known. The

¹¹⁷⁵ Faninger, 1994/95, 562; Faninger, 1988, 7-8.

¹¹⁷⁶ Faganel, 1999, 13.

¹¹⁷⁷ Valenčič, Faninger, Gspan-Prašelj, 1991, 832.

sales catalog was compiled by Henrik Viljem Korn. Henrik completed his list of 4109 volumes on 4 August 1821. After the end of the religious ban, Korn settled as one of the first Protestants in Ljubljana, and he became an independent bookseller in Ljubljana in 1788. On December 31, 1790 and February 7, 1793 Korn wrote to Zois from Vienna. The Ljubljana Lyceum library did not buy all Zois' books, since some of them the Lyceum already had, while Žiga Zois' nephew Karl Zois offered mainly technical and natural works from his inherited estate. On 9 April 1824, the government paid 7000 guildens, and the books were transferred to Lyceum between June 24, 1824 and August 1, 1824.¹¹⁷⁸

Lavoisier's novelties influenced Zois through the work of Madame Elisabeth Fulhame, a wife of Dr. Thomas Fulhame. In the High English society, Mrs. Fulhame communicated with the most important physical-chemists of her era, among them with Joseph Priestley. Her reflections on Phlogiston discussion with the traces of later catalytic theory would excite Lavoisier, but he lost his head few months before Elisabeth Fulhame's publication which would surely delight him as the way of the subsequent discovery of catalysis. The translator Augustin Gottfried Ludwig Lentin (1764 Dannenberg in Lower Saxony-1823 Sülbeck near Eimbeck) apologized as he somewhat changed the title because he did not want to mention old-fashioned phlogiston anymore in November 1797.¹¹⁷⁹ Fulhame signed her own introduction in November 1794, but in October 1793 the chemical research completely changed its course¹¹⁸⁰ after Lavoisier's revolution in the nomenclature, weighting, and research approach to the chemistry and fire. Fulhame divided her research on the formation of metals,¹¹⁸¹ reduction of metals with phosphorus, hydrogen,¹¹⁸² and light,¹¹⁸³ and finally

the oxidation of metals¹¹⁸⁴ mostly in hydrogenous media.¹¹⁸⁵

Zois bought at least three Berthollet's books and used marbled red-green paper for their inner cover. Among them Zois acquired Berthollet's work printed in 1803, although there is no note about it in Kopitar's Schober's, Zupan's catalogues or in Kalister-Korn's sales catalogue. The book was bound, as usual, to Zois' brown leather with marbled red-green inner covers. Berthollet began by explaining the cohesion force without mentioning Bošković,¹¹⁸⁶ and he published a special chapter about the caloric.¹¹⁸⁷ Berthollet devoted his last sixth section of the first volume to the operation of the atmosphere,¹¹⁸⁸ and then in the second volume Berthollet explained the chemical activity of the various substances. Berthollet dedicated his last fifth section of the second volume to plants and animals, therefore to the botany and zoology. Zois' copy of that book was one of the inexpensive Parisian editions bound in somewhat thicker colored twofold paper with randomly cut paper edges on hundred-five pages of A5 format. It was divided in fifteen articles illustrated with many experiments, and the very last was summary of them all. Berthollet seldom cited his colleague Fourcroy.¹¹⁸⁹

Lacoste was a professor of natural science at the Central Schools of the Puy-de-Dome district, famous for Pascal's barometric experiments. Zois acquired his work issued in 1803 under the title *Observations of the Volcanos de l'Avergne with notes of diverse objects of the course of mineralogy* Zois bound it in brown leather with flowers on the spine and marmorated red-blue inner covers full of flowers. He also described the exploration of the Sicilian volcanoes of the "immortal" Dolomieu, Haüy and the large mineralogy of Fujis de Saint-Fond.¹¹⁹⁰

Johan Heinrich Voigt (* 27. 6. 1751 Gotha; † 6. 9. 1823 Jena) began teaching in gymnasium in Gotha in 1774, where he published the astronomical part

¹¹⁷⁸ Kidrič, 1939, 9.

¹¹⁷⁹ E. Fulhame, *An Essay on Combustion with a View to a new Art of Dying and Painting. Wherein the Phlogistic and Antiphlogistic Hypotheses are Proven Erroneous*. J. Cooper, London, November 5, 1794; Reprint: James Humphrey, Philadelphia, 1810; Translation: *Versuche über die Wiederherstellung der Metalle durch Wasserstoffgas, Phosphor, Schwefel, Schwefellber, Geschweltes, Wasserstoffgas, Gephosphorte Wasserstoffgas, Kohle, Licht und Sauren. Aus dem Englischen Übersetzt von A. G. L. Lentin*. Göttingen: Dieterich, 1798 (NUK-8709), XIV; Svoljšak, Vidmar, 2019, 39, 156-157.

¹¹⁸⁰ Fulhame, 1798, IX.

¹¹⁸¹ Fulhame, 1798, 17.

¹¹⁸² Fulhame, 1798, 164.

¹¹⁸³ Fulhame, 1798, 206.

¹¹⁸⁴ Fulhame, 1798, 233.

¹¹⁸⁵ Fulhame, 1798, 237.

¹¹⁸⁶ Svoljšak; Vidmar, 2019, 11; Berthollet, *Essai de statique chimique*. Paris: Didot, 1803, 23 (NUK-8583).

¹¹⁸⁷ Berthollet 1803, 139.

¹¹⁸⁸ Berthollet 1803, 470.

¹¹⁸⁹ Berthollet, 1803, 96.

¹¹⁹⁰ Lacoste, 1809, 24, 39, 47, 48, 155.

of the court calendar. In 1789, he received his PhD in philosophy at the University of Jena, where he took over the Department of Mathematics, and in thirteen years he also began to teach physics. From 1786 to 1799 he took over the editing of the *Magazin für das Neueste aus der Physik und Naturgeschichte*, founded by its first editor, Ludwig Christian Lichtenberg (* 1737; † 1812). Voigt issued volumes 6 to 12 with numerous Hacquet's papers. From 1797 to 1806 he published twelve volumes of a similar magazine in Jena, with a slightly changed title *Magazin für das Neueste Zustand der Naturkunde*, in which Hacquet has no longer published. Voigt wrote papers on mathematics, fire, air, electricity, magnetism, optics, comets and the history of the calendar.

Zois also read journals of Lorenz Florenz Friedrich von Crell (* 1744 Helmstedt (Helmstädt) in Lower Saxony; † 1816 Göttingen) who became a professor of philosophy and medicine in 1773 at Helmstedt University, and after its abolition he took over the Chemistry Department in Göttingen in 1810. He published six volumes of the first German chemical journal *Chemischen Journal für die Freunde der Naturlehre, Arzneygelahrtheit, Haushaltungskunst und Manufacturen* in the city of Lemgo by publisher Mayer from 1778 to 1781. The magazine continued as *Neuesten Entdeckungen der Chemie* in Leipzig from 1781 to 1784, when Crell edited the volumes 1-12 with the publisher Weygandsh. In both magazines Hacquet published his works, also in supplements (Beytrage). Crell edited two volumes of *Chemisches Archiv* in 1783, which continued with volumes 1-8 as *Neues Chemisches Archiv* from 1784 to 1791. From 1784 to 1803 he published forty volumes of the *Chemische Annalen für Freunde der Naturlehre, Arzneygelahrtheit, Haushaltung und Manufakturen* with J. G. Müller. From 1785 to 1790 he published six volumes of *Beiträge zu der Chem. Annalen*. In 1785 and 1786 he published five volumes of *Auswahl aller eigenthüml. Abhandl. Aus d. Neuest. Entdeckungen d. Chemie*. In 1798 he published the first volume of the magazine *Neuestes Chemisches Archiv*.¹¹⁹¹

Gabriel Jars (* 1732; † 1769) from Lyon was the son of the director of the mines in Ghessy and Sain-Bel. In 1757 and 1759, together with his older

companion Guillot-Duhanel,¹¹⁹² Jars travelled to Saxony, Austria, the Bohemian Lands, Tyrol, Carinthia, Styria, Schemnitz (Banská Stiaavnica) and other cities of Hungarian kingdom. In 1758, Jars studied the compressed air at K. Hell's mine dewatering pump in Banská Štiavnica, which was collected as a snow after flowing- evaporating through the valve. Jars wrote about the phenomenon a year before his death. After returning from those first of his journeys across Europe, Jars was elected as a correspondent member of the Parisian Academy on 10. 1. 1761, and on 19. 5. 1765 he was elected as a regular member in the race with his first rival counter-candidate, first nominee Lavoisier. Of course, Lavoisier later as a chemist completely overshadowed most of Jars' achievements. Zois bought Jars' travelogue posthumously edited as a scientific journal, like scientific itineraries. Zois also purchased Gren's *Physical Journal*, where Tobias Gruber investigated Jars' vacuum phenomenon at the mine pump valve on January 1, 1791.

A particularly typical example of the Carniolan imports of Parisian science at the centre of Illyrian province was once Zois's copy of Joseph Izarn's (1766 Cahors-1834 Paris) *Leçons élémentaires de Physique*. In 1793 Izarn became the Parisian professor of physics at Lucée Bonaparte and in 1811 he was a general inspector of the university. A year prior to the publication of a book which Zois acquired, Izarn published his *Manuel du galvanisme* in 1804 after he published some guesses about the origins of meteorites. Zois' bookbinder bind Izarn's books in a blue-gray paper of A6 format reinforced in the back side with the page 38 of the printed matter about Ethiopia, and the front is reinforced with the same print of p. 35. In his first volume Izarn described bodies, attractive forces and Lavoisier's caloric with Haüy's data included. The first Izarn's panel-plate showed a vacuum experiment by burning the candles in a bowl inside the container.¹¹⁹³ The last fourth panel with pictures at the end illustrated the barometer, thermometer, electrophorus, magnetic needle in nature and distillation container, while he placed the rest of the image panels between the text. The third panel-table showed the pulleys, the

¹¹⁹¹ J.C. Poggendorff, *Biographisch-Literarisches Handwörterbuch*. Leipzig 1863-1898, 496.

¹¹⁹² Jean Pierre François Guillot-Duhanel (* 31. 8. 1730 Nicorps by Coutances; † 19. 2. 1816 Paris).

¹¹⁹³ J. Izarn, *Leçons élémentaires*, Paris 1805, 1: 64/65, fig. 5.

second the capillarity and the Archimedes' law.¹¹⁹⁴ The second part of that textbook covering optics and electricity was never published.

Lindenau's book of 1809 contained recommendations for barometric calculations of altitudes. Bernhard August von Lindenau was a lawyer, astronomer, politician and collector of Florentine paintings. He wrote about Venus and Mercury, and he designed his book later purchased for Zois' collection three years earlier with Lindenau's letters mailed to Zach in 1805; during the Napoleonic wars Lindenau did not finish his book due to his lack of available libraries needed for references. Lindenau's foreword was dated in Seebach's Observatory on January 1, 1809. In the last table, he published observations of Humboldt's collaborator Jabbo Oltmanns (Ottmans, *1783 Wittmund (Ostfriesland); † 1833), and the captain of engineers Pierre Alexandre Joseph Allent (1772-1837 Paris). Lindenau also respected geographic records of amateurs. Lindenau used the barometric equations of Laplace, de Luc,¹¹⁹⁵ Mariotte and Halley.¹¹⁹⁶ Lindenau also discussed vacuum experiments¹¹⁹⁷ and Bošković's measurements.¹¹⁹⁸

Zois had an Italian translation of Davy's *Agricultural Chemistry* with one single copperplate, while NUK from other sources acquired the same book in German one-year earlier translation.¹¹⁹⁹ In 1815, the Italian translations were also published in Naples and Florence, and in 1819 in Paris. Davy divided his discoveries into lessons which he taught at the Royal Institution. He was interested in the atmosphere, the plants and the improvement of soil by burning, probably because of the addition of carbon in the form of ash. He finished the book with the results of experiments, where he particularly considered Gay-Lussac's research of carbon dioxide, oxygen and hydrogen.¹²⁰⁰

Jakob Anton von Zallinger zum Thum served in Dillingen in 1770. In 1776 and 1777, he taught physics in Innsbruck, followed by his lectures on theology. He was the brother of the other two

important Jesuits and G. Gruber's associates. His brother, Franz Seraphim Zallinger,¹²⁰¹ the professor of physics in Innsbruck from 1778, took over the chair after their brother Jacob Anton.¹²⁰² Franz Zallinger was an important advocate of Bošković's ideas, while he published a great deal about electricity. Franz Seraphim and Jakob Anton's older brother Joannes Zallinger¹²⁰³ was also a Jesuitical physicist in Innsbruck. Jakob Anton von Zallinger independently paginated the leaves in his introduction, while in his main text he paginated every page. In the introduction he noted Newton, Bošković and even Locke.¹²⁰⁴ Despite of this scientific introduction, the basic text was more philosophical with logic, the philosophy of nature (metaphysics), psychology and natural theology included.

Under Gruber and Maffei's influence, baron Zois bought the basic works of Bošković's physics. Even though, unlike Baron Erberg, Zois did not acquire Newton's original works except in Hill's list of London Royal Society papers, Zois bought the basic works of Newtonians, such as the book of Englishman Keill, which was also used by the Franciscans of Novo Mesto. Zois also read the Dutchmen 'sGravesande and Musschenbroek's works; under the influence of Bošković the Jesuits of Ljubljana also purchased their books, while the Franciscans of Novo Mesto mostly used Musschenbroek's work. Above all, Zois read F. Bacon as the leading model of the scientists of the London Royal Society.

Zois bought the second edition of Hill's summaries of London RS lectures on science, botany, animals, minerals, medicine, antiques and miracles without mathematics-based science. Hill devoted his work to Martin Folker, the president of the Royal Society. Hill first began to undertake agricultural inventions which he called Arts. He praised the invention of the secretion of pure water from the salt.¹²⁰⁵ He described the uncontrolled eating habits of a boy,¹²⁰⁶ the inner parts of the fish,¹²⁰⁷ the

¹¹⁹⁴ Izarn, *ibidem*, 202/203, 134/135.

¹¹⁹⁵ Lindenau, 1809, 149, XII, XXI.

¹¹⁹⁶ Lindenau, 1809, XXI.

¹¹⁹⁷ Lindenau, 1809, XIX.

¹¹⁹⁸ Lindenau, 1809, L.

¹¹⁹⁹ Davy. 1814. *Elementen der Agrikultur-Chemie* (NUK – 9535, Brown marbled cover

¹²⁰⁰ Davy, 1815, 113.

¹²⁰¹ Franz Seraphim Zallinger zum Thurn (Zeilinger, * 14. 2. 1743 Bolzano; SJ 9. 10. 1760 Upper German Province; † 2. 10. 1828 Innsbruck).

¹²⁰² Hellyer, 2004, 238.

¹²⁰³ Joannes Baptist Zallinger (* 16. 8. 1731 Bolzano; SJ 9. 10. 1747; † 11. 7. 1785 Bolzano).

¹²⁰⁴ Zallinger, 1773, 4^v, 5^r.

¹²⁰⁵ Hill, 1780, 17.

¹²⁰⁶ Hill, 1780, 59.

¹²⁰⁷ Hill, 1780, 112.

Table 6-19: Zois' books about Vacuum and Electricity Physics

Author	Year of printing	Title (with Selling Prices forints (ft): kreuzer)	Place	Catalog
Kirwan	1796-1799	Physisch-chemische Schriften (Berichte)	Berlin/ Stettin: Nicolai	Zo, catalogs on sheets Additional list
Fulhame	1798	Versuche über die Wiederherstellung	Göttingen	
Jars, Gabriel	1774	Voyage metallurgique. fig. 4. (1:30). = Voyages metallurgiques, ou recherches et observations sur les mines et forges de fer. La fabrication de l'acier, celle du fer-blanc, et sur plusieurs mines de charbon de terre, faites depuis l'année 1757 jusques et compris 1769, en Allemagne, Suede, Norwege, Angleterre et Ecosse. Suivies d'un mémoire sur la circulation de l'air dans les mines, (etc.) (NUK-11139)	Lyon: Reynault	Z, page 23
Jars, Gabriel	1777 - 1785	Metallorum in Kern = Metallurgische Reise zur Untersuchung der vornehmsten Eisen- Stahl- Blech- und Steinkohlen- Werke in Deutschland, von Jahr 1757 bis 1769. Aus dem französischen übersetzt und mit Anmerkungen beyleitet von Carl Abr. Gerhard. 4 Bände (NUK- 11180. 8°)	Berlin: Himburg	Zo, catalogs on sheets Additional list
Lull	1663	Chemie	Rouen (Rothomagi)	Zo, catalogue in a thick book, page 51
Walley (Wallerius, Johan Gottschalk (b. 1709; d. 1785)	1760	Chym, Physik. (0:30). = 1760. <i>Chemiae physicae Pars Prima, de Chemiae natura ac indole and Ejusdemque Historia...</i> Stockholm: L. Salvius (NUK: GS 8708),	Stockholm	NUK, MS 667, page 9
(Zannichelli, Gian Girolamo (Joanne Hieronymo, * 1662; † 1729)	1713	Dissertatio Phys. Chim de Chal. De Ferro. (0:20). = De ferro ejusque nivis praeparatione: dissertatio physico-chimica, in qua varia de ipso metallo explicantur. Venetiis: Andrea Poleti (NUK-11126)	Vienna	NUK, MS 667, page 9
Bošković	1749	Sopra l il turbine Dissertazione (NMLJ-4069)	Roma	Zo, catalogs on sheets
Bošković, Rudjer	1763	Philosophia Naturalis (NUK-8179; NUK-8180).	Venetii	Zo catalog on unbound sheets
Dufieu, Jean Ferapie (* 1737; † 1769)	1760	Manuel de Physique (, ou, Maniere courte et facile d'expliquer les phénomènes de la nature). (0:45). (NUK-8387) second edition: first edition in 1758 in Paris.	Lyon: Regnault	Z, page 17
Nollet, J.A.	1760	Lettres sur l'elettricite. (2 vol, 30 ft). (NUK-8419)	Paris	Z, page 17
Nollet, J.A.	1753-	Leçons de physique expérimentalle (6 vol,	Paris: Guérin	Z, page 17

	1764	2.26 ft). (NUK-8259)		
Nollet, J.A.	1770	L'art de experiance. Paris (3 vol, 1.16 ft). (NUK-8260)	Paris	Z, page 17
Nollet	1746	Essai sur l'électricité des corps (0:20). (NUK-8262)	Paris: Les frères Guérin	Z, page 144
Nollet	1749	Recherches sur les causes particulaires des phénomènes électriques (0:24). (NUK-8261)	Paris: Les frères Guérin	Z, page 144
Franklin, Benjamin	1773	Oeuvres de Benjamin Franklin... traduites ... Jacques Barbieu Duborg (1709 Mayenne–1779 Paris)... (2 vol, 2:00) (NUK-8473)	Paris: Jacques-François Quillau	Z, page 17
De la Fond, Sigaud (* 1730; † 1810)	1775	Description et usage d'un cabinet du physique. (0.30). (NUK-8216)	Paris	Z, page 18
Priestley, J.	1771-1780	Historie Electrit. (2 vol, 1 ft 30). (NUK-8167)	Paris	Z, page 18; Zo, catalogue in a thick book, page 85
Izarn, Joseph	1805	Leçons élémentaires de physique et chimie expérimentales (NUK-8348)	Paris	Z, page 24
Priestley, Joseph	1775-1780	Experiences et observations sur différentes especes d'air. (3:00). (NUK-8443)	Paris	Z, page 24
Lindenau, Bernhard August	1809	Tables barométriques. (1:00). (NUK-4248).	Gotha	Z, page 25
Cavallo, Tiberius	1781	A Treatise on the nature and properties of air and permanently elastic fluids. (3:30). (Zois-NUK-GS II 8454). German version 1783, updated English reprint 1784	London	Z, page 45
Cavallo, Tiberius	1782	A complete Treatise on electricity. (50 kr) (Zois-NUK-8224). Translation: 1783. Vollständige Abhandlung der theoretischen und praktischen Lehre der Elektrizität... Leipzig: Wiedmann (Zois-NUK-8219)	London	Z, page 45; Zo, catalog on unbound sheets, no. 5
Cavallo, Tiberius	1783	Vollständige Abhandlung der theoretischen und praktischen Lehre der Elektrizität... (NUK-8219)	Leipzig: Wildmanns Erben und Reich	Zo, catalog on unbound sheets no. 13
Cavallo, Tiberius	1785	The history and practice of aerostation. (0:40) (NUK-8478)	London	Z, page 45
Watson, Richard (* 1737; † 1816)	1782	Chemical essays. Second Edition, 1-5. (3:30).	London	Z, page 45
Kirwan, Richard (* 1733; † 1812)	1787	An essay on phlogiston, and the constitution of acids. (0:20). (NUK-4907); Kirwan. 1783. Versuche und Beobachtungen über die specifische Schwere und anziehung Kraft verschiedene Salzarten; und über die wahre neuentdeckte Natur des Phlogiston's. Aus dem Englischen übersetzt und mit einen Vorreide Verfasern von D. L. Crell. Etc.	London: Elmsly	NUK, MS 667, page 45

		Berlin und Stetlin: Friedrich Nicolai (Zois; NUK-8428).		
Nicholson	1790	The First Principle of Chemistry. (0:20).	London	Z, page 45
Hill, John (* 1714?; † 1775)	1780	A review or the works of the Royal Society of London (1:00) 2 nd edition 265+3 pages 28 cm 4o (NUK-8470)	London	Z, page 45
Ambshell	1782(=1791-1793)	Anfangsgrunde (3:00) (NUK-21382; NUK-8439)	Wien: Schmidtschen Schriften	Z, page 47
Liebes, Antoine (* 1752; † 1832)	1804	Anfangsgrunde der Physik, übersetzt und mit Anmerkungen hrsg. Von J.F. Droysen. 2 Bände. (2 :50). (NUK-8503). Original. Liebes. 1801. <i>Traité élémentaire de physique</i> . Paris: Deterville	Jena: Johann Michael Mauke	Z, page 47
Haüy, René Just (* 1743; † 1822)	1804	Gründlehre der Physik. 2 Bände. 8°. (1:45) Translation from French language. Wien (NUK-8504). In NUK also a French original: Haüy. 1806. <i>Traité élémentaire de physique</i> (NUK-22077) in Haüy. 1809. <i>Tableau comparatif des résultats de la cristallographie et de la analyse chumique</i> . Paris: Courcier (NUK-9086)	Wien/Weimar: landes-Industrie-Comptoirs	Z, page 47
De Luc, Jean André (* 1727; † 1817)	1776	Untersuchungen über der Atmosphäre (2:00). (NUK-8317; NUK-8490). Original: 1772. <i>Rescherches sur les modifications de l'atmosphere</i> . Geneve	Leipzig: Müller	Z, page 47
de Saint-Fond, Fayas (* 1741; † 1819)	1783	Beschreibung der Versuch mit der Luftkugel 8o. (0:48). (NUK-9395). = Faujas de Saint-Fond, B., <i>Beschreibung der Versuche mit der Luftkugel</i> , übersetzt von Abbé Uebelacker, mit einer Abhandlung derselben, wodurch erwiesen wird, dass ein deutscher Physiker von XIV Jahrhunderte der Urheber dieser Erfindung sey, Wien 1784, with a note about Montgolfier. Wien: Kurzbeck (NUK-8395 Zois' books; NUK-8182; NUK-8183)	Wien: Kurzbeck	Z, page 47
Rohr, Julius Bernhard von (* 1688; † 1742)	1754	Physikalische Bibliotheqe. (ed. Kästner whose books Gruber used) (0:40). (NUK-37)	Leipzig	Z, page 47
Gren, Friedrich Albrecht Karl (* 1760; † 1798)	1799-1812	Annalen der Physik. 42 Bände (47:10) (NUK-8153)	Halle: Rengerschen Buchhandlung	Z, page 47
Porta, Giovanni Batista	1650	Physiognomoniae coelestis libri sex. (Auersperg's book). (0:30). Not in Cobiss, maybe bind to Porta. 1618. <i>De humana physiognomia</i> . Grancofirti: Hoffmann (NUK-4992)	Rothomagi (Rouen) in France	Z, page 139; Zo, catalogue in a thick book, page 51
Delius, Heinrich Friedrich von	1782	<i>De cholelithis obseruationes et experimenta, nec non de iconibus pathologico semeioticis consilium</i> . Erlangae: Wolfgangum Waltherum, 1782 (0:30) (NUK-GS I 11987)	Erlangen: Walther	Z, page 139
Martin	1759	Elements of optics (0:40).	London	Z, page 144

Martin, Benjamin (* 1705; † 1782)	1766	Air Pump. (1:00). (NUK-8539)1208	London	Z, page 144
Neumann, Johan Philip	1808-1812	Compendiaria Physica Instituto in usum tironum conscripta. Tomus 3, Cum 3 figuris (NUK-8215)	Graecii: Ferstl	Z, page 144
Anonymous	1761	Dictionaire des art de Science. Franc. Latin. et Angl. (1:30)	London	Z, page 147
Beccaria, Giambattista (* 1716; † 1781)	1772	Elettricismo artificiale ¹²⁰⁹	Torino	Zo. catalog on unbound sheets
Poli, Giuseppe Saverio (* 1746; † 1825); Goivanni Maria della Torre (* 1713; † 1782) ¹²¹⁰	1774	Lettera al p.d. Giovanni Maria della Torre intorno agli effecti de fulmini. Napoli. 8°.	Napoli	Zo, catalog on unbound sheets; Z, page 144
Bartoli, Daniello (* 1608; SJ; † 1685)	1682	(Traite) del Ghiaccio e della Coagulatione: trattati. 8o	Bologna: Recaldini	Zo, catalog on unbound sheets
Davy, Humphry	1815	Elementi di Chemica Agraria (rurale). Vol 1	Firenze	Zo, catalog on unbound sheets
Zallinger zum Thun, Jakob Anton	1773	Interpretatio Naturae, seu philosophia Newtoniana methodo exposita, et academicis usibus adcommodata. Augustae Vindelicorum: Joseph Wolff. 1-3 (NUK-8161; FSLJ-5 c 68-71).	Augsburg	Zo, catalog on unbound sheets, no. 21
Epp, Franc Xav.	1772	Problemata Electrica, Reprint: Epp. 1773. Problemata Electrica publicae disputatione proposita a P. Franc Xav. Epp S.J. in electorali Lyceo Monacensi Professore Physices p.o. Defentibus Benedicto Knilling, Josepho Hall, Joseph Widman. Monaci: Joannis Nep. Friz. Pars I (146 pages) pars I (83 pages) (NUK-8558).	Vienna	Zo, catalog on unbound sheets, no. 23
Herbert, Joseph	1772	Theoria electricorum conscripta a P. Josepho Herbert e S.J. Viennae: Joh.Thom. nob. De Trattner (NUK-8392). Reprint: Herbert. 1773. Theoria electricorum	Vienna: de Trattner	Zo, catalog on unbound sheets, no. 24
	1773	Nova Acta Regiae Societatis scientiarum Upsaliensis. Volumes 1, II, III 1773-1780 (NUK-156).	Uppsala: Johan Edman	Zo, catalog on unbound sheets, no. 25
Musschenbroek	1754	Dissertatio physica experimentalis	Vienna: de Trattner	Zo, Catalogue from the year 1812,

¹²⁰⁸ Martin, 1766, *A description of the nature, construction, and use of the Torricellian, or simple barometer*. London: self-publishing (NUK-8540). Other Martin's inventions are described in his book with signature NUK-8544.

¹²⁰⁹ Translation of Latin printing in the year 1751 in Torino or Rome, based on Franklin's theory.

¹²¹⁰ Poli supported Franklin's lightning rods.

				unbound sheets, 4°, no. 88
Gravesande	1749	Philosophia Newtoniana interpreta. Venetia (0:70) not identical to: Physices elementa mathematica experimentis confirmata; sive introductio ad Philosophiam Newtonianam. (NUK-4241).	Venetia	Zo, Catalogue from the year 1812, unbound sheets, 8°, no. 50

Table 6-20: Zois's books on the philosophy of vacuum

Author	Year	Price and Title	Printing place	Catalogue
Bacon von Verulam	1665	(0:30) Francisci Baconi Baronis de Verulamio, Vice Comitis P. Albani, Sumi Anglice Cancellarii. Opera omnia, qua extant: philosophica moralia, politica, historica. Tractaus nempe de dignitate et augmentis scientiarum. Historia ventorum. Historia vitae et mortis. Scripta de naturali et universale Philosophia. Nova Atlantis. Historia regni Henrici VII Regis Anglice: opus vere politicum. Sermones fideles, sive Interiora rerum. Tractatus de sapientia veterum. Dialogus de bello sacro. Opus illustre in felicem memoriam Elisabethae Reginae. Imago civilis Julu Caesaris. Imago civilis Augusti Caesaris. In quibus complures Alii Tractatus, quos brevitatis causa raetermittere visum est, comprehensi sunt. Haltenus nunquam conjunctim edita, jam vero sumo studio collecta, uno volumine umprehensa, et ab inumeris mendis repurgata . Cum indice rerum et verborum universali absolutissimo. His praefixa est auctoris vita (cum ejus effigie) (NUK-5022, folio)	Francoforti Ad Moenum: Impensis Joanis Bapt. Schönwetteri	NUK, MS 667, page 3
Bacon von Verulam	1762	(0:12) Francisci Baconis de Verolamis Summi Anglice Cancellarii, Novum Organum Scientiarum. Editio I-ma Veneta. (NUK-4628, 8°, A4/4a)	Venetiis: Gaspar Girardi	Catalogue issued in 1812, unbound sheets. In folio, fasc. 19, item no. 52
Swedenbor g, Emanuel	1734	(6:00) Emanuelis Swedenborgii Sacrae Reg. Majestatis Regnique Swetiae Collegii Metallici Assessoris. Principia rerum naturalium sive novorum tentaminum phaenomena mundi elementaris philosophice explicandi. (Tomus primus:) Cum figuris aeneis [28 tabulis expressis] (Tomus II:) Emanuelis Swedenborgii etc. Regnum subterraneum sive minerale de ferro, deque modis liquationum ferri per Europam passim in usum receptis: deque conversione ferri crudi in chalybem: de rena ferri et probatione ejus: pariter de chymicis praeparatis et	Dresdae, Lipsiae: Sumptibus Friderici Hekelii	NUK, MS 667, page 3

		cum ferro et ritricto ejus factis experimentis etc. etc. Cum figuris aeneis [36 tabulis expressis et una charta] (Tomus III) Emanuelis Swedenborgii etc. Regnum subterraneum sive minerale de cupro et orichalco deque modis liquationum cupri per Europam passim in usum receptis: de seretione ejus ab argento: de conversione in orichalchum; inque metalla diversi generis: de lapide colaminari: de zinco: de vena cupri et probatione ejus: pariter de chymicis praeparatis, et cum cupro factis experimentis etc. etc. Cum figuris aeneis [89 tabulis numeratis et una sine numero expressis (NUK-8914, folio)		
--	--	--	--	--

formation of jewels,¹²¹¹ plants with pure mercury in the roots,¹²¹² the natural formation of crystals,¹²¹³ the Earth's layers,¹²¹⁴ natural golden leaves maybe related to gold-leaf electroscope¹²¹⁵ precious stones,¹²¹⁶ and the Turkish wall.¹²¹⁷

Zois' books about physics mostly described the phenomena of electricity. There, despite Bošković's, Buffon's and Franklin's influence, Zois also read a lot of the works of their antagonist Nollet. Zallinger's Jesuitical thinking about Newton in Zois' library shows Gruber's influence. Zois also bought the book of Epp from Munich with the description of Richmann's fatal accident.¹²¹⁸ Zois also read the books of Ambshell's professor Herbert with his notes about Nollet,¹²¹⁹ Bošković's friend Beccaria, Poli, and Toaldo who supported Zois' faith in the advantages of Franklin's lightning rods. Zois was deeply interested in Galvani and Volta's discovery, just like Kersnik, Marmont, Zelli and Napoleon himself; so, Zois bought today lost books of Nicholson and Davy, but he did not have the original works of Galvani or Volta. Volta could have been foreign to Zois even by the political aspects. Volta used to be a Napoleonic senator, although Volta taught in Pavia near Zois's father's native areas in Bergamo. Davy visited Zois during his trips to the Alps, and their conversations certainly encouraged Zois reading or even active

domestic experimenting with the electrical phenomena.

The Slovenian Slavistics oriented visitors liked to mention Zois's home as an image of a laboratory following the example of de la Fond and Dufieu's description in Zois's books; Zois certainly tested the Voltaic cell at home. In his library, Zois also had many school disputations from the Habsburg monarchy and neighboring countries, including Epp's Munich notes. But Zois was less interested in mesmerism, perhaps even because of Franklin's critics of Mesmer. Zois was considered incurable after his unsuccessful searches during the first troublesome years; so, the books about Mesmer's successes in Vienna and Paris arrived in the library of the Lyceum of Ljubljana from other sources.

The books about the phlogiston theory also marked Zois' library reading, where we find Stahl and the chief gravedigger of his theory, Lavoisier. In the meantime, Zois read other researchers of phlogiston, such as Priestley or Kirwan; Zois bought two books of both famous British researchers.

Zois was also interested in the composition of gases in the atmosphere; so, he read the descriptions of Cavallo and Priestley's experiments, as well as measurements of Jean-André De Luc, who supported Born's candidacy for the Royal Society of London. Baron Born corresponded with the baron Žiga Zois, Gruber and Hacquet, and Zois bought Born's book about crystallography; but Zois did not have Born's scientific-Freemasonic Viennese newsletter, which included the papers of Hacquet and (Tobias) Gruber.

¹²¹¹ Hill, 1780, 163, 176.

¹²¹² Hill, 1780, 183.

¹²¹³ Hill, 1780, 202.

¹²¹⁴ Hill, 1780, 204.

¹²¹⁵ Hill, 1780, 231.

¹²¹⁶ Hill, 1780, 242.

¹²¹⁷ Hill, 1780, 252.

¹²¹⁸ Epp, 1773, 1237.

¹²¹⁹ Herbert, 1772, 333.

While Zois's northern-Italian cousin Valvasor based his chemical and vacuum reflections on numerous readings by Robert Boyle, Boyle's work was only a remote history for Zois. As Zois was accompanied by a similar group of patronized fans as Boyle, Zois bought Boyle's work for his library. Nevertheless, Zois has also purchased many books on vacuum pumps, including those from Benjamin Martin's pen. Like Vega in Vienna or Vodnik in his Ljubljana News journal, Zois was also attracted by Montgolfier's ballooning. So, Cavallo, who was one of the most popular Zois's scientific sources, also liked Montgolfier's report. At the first contacts of Slovenes with the French Revolutionary armies, Vodnik, otherwise not yet fully convinced Napoleon's supporter, also started to publish the news from Paris. On 22 November 1797, Vodnik reported on André-Jacques Garnerin's Parisian "ride in the air" (October 22, 1797), when he "bled the air under the balloon" and "swam as a spruce tree on the water." At 700 m above sea level above Paris he used the modern shape of the parachute designed as an umbrella with a diameter of 10 m with sixteen ropes which did not open immediately after the jump. Vodnik reported to the residents of Ljubljana only one month after the event! Brothers Montgolfier flew fourteen years earlier, and similar attempts were soon made by the other people of Vienna. Vodnik certainly examined Zois's copy of the German translation of Montgolfier's book (1783), which was evaluated to 6 kr. In that translation, the priest Uebelacker on pages 9-36 described the history of ballooning with the achievements of Lana Terzi, Leibniz, Cavallo and the Dominican Joseph Galien's (Gallien, * 1699 Saint-Paulien in France; † 1782 Avignon) designed at the high school in Avignon in 1755. Saint-Fond devoted the book to the French field marshal, and on the panel number nine he painted Lana's boat. Among the other nine copperplates, he immortalized many details of Montgolfier's experiment with the shape of devices and the filling of the balloon on the plate 1.

In the spirit of the then changes, the transfer of novelty among the scholars acquired the readings of extremely new scientific journals, including the papers published by Zois's once confidential friend Hacquet. Their friendship slightly cooled down after Hacquet's dispute with Gruber in the autumn of 1775 and the obvious Hacquet's fiction about his own French-Russian descent. Thus, Zois acquired Gren's *Annalen der Physik* (1799-1812), later the

leading journal of mathematical physics, Hill's report on the Royal Society of London, and acts of the Uppsala Academy. For the years 1774-1781 Zois also got the journal *Der Naturforscher* from Halle where Leopoldina society also worked. In *Der Naturforscher* Hacquet also published in 1776, 1777, and 1779. The Volumes 1-13 issued in 1774 to 1779 were edited by Johann Ernst Emmanuel Walch (* 1725; † 1778), and Johann Christian Daniel Schreiber (* 1739; † 1810) edited the volumes 14 to 30 between 1780 and 1804. The magazine was published by J. J. Gebauer, later by his widow along with their son Johan Jacob.

From 1790 to 1794 Friedrich Albrecht Carl Gren (* 1760; † 1798) issued the *Journal der Physik* magazine, and then renamed it to the *Neues Journal der Physik* until 1798. These were the predecessors of *Annalen der Physik*, the leading German physics journal of the nineteenth century from 1799 until 1896. Its first editor was Ludwig Wilhelm Gilbert (* 1769; † 1824). Gilbert was a professor of physics in Halle, until he arrived at the University of Leipzig in 1811; right then Zois stopped buying his magazine, as he had apparently more connections with Halle than in Leipzig. There were also problems with the Napoleonic continental blockade which provided obstacles to Zois's desires to obtain German language journals from the north. After Gilbert's death, the editorship of his magazine was taken over by Johann Christian Poggenдорff. Hacquet published his letter in Gilbert's *Annales*, which he dated at the then Habsburgian Lviv on July 1, 1801. Since 1787, Zois has also purchased a *Magazin für die Naturkunde Helvetiens* (Zürich: Orell, Gessner, Fussli & co.). So, Zois also had Hacquet's publication printed there in 1789. Zois acquired many other periodicals, including the prints of *Gesellschaft in Wippertal*, *Acta societatis Jablovianae* of Leipzig based Prussian *Fürstliche Jablonowskische Gesellschaft der Wissenschaften*, and, of course, *Laibacher Wöchenblatt* of 1817-1818.

Zois bought F. Bacon's collected works issued on 354 pages in 1762. Those pages were supplemented by additional unpagged aphorisms. F. Bacon described experiments with atomism,¹²²⁰ and then he started with mathematical reasonings.¹²²¹

¹²²⁰ Bacon, 1762, up to pages 361.

¹²²¹ Bacon, 1762, up to page 372.

6.7.10 *Swedenborg's Improvements for the Baron Zois*

Emanuel Swedenborg certainly published one of the most remarkable and expensive books in his three volumes which Zois kept in his library. The work originated in Swedenborg's initial scientific era, and its purchase by no means proves any Zois's enthusiasm for the subsequent Swedenborgian spiritism published after 1742, under the possible influence of Croat Milan Nejedel, since Zois did not acquire those later books. The later cult philosopher Emanuel Swedenborg (* 1688; † 1772) studied in Uppsala, but in 1724 he refused to accept the offered mathematical chair there, although he already published many works about technical solutions. In 1731 he published *Opera philosophica et mineralogica*, which Zois did not buy. Swedenborg dedicated his first volume to Ludwig Rudolf, the Duke of Braunschweig (Bunswick) and Lunenburg (Lüneburg). Swedenborg dedicated his second volume to Wilhelm the Provincial Count of Hesse, the descendant of the owner of the first modern European Astronomical Observatory. Swedenborg dedicated his thickest third volume to Friderik I the King of the Swedes, Goths and Vandals. As it later became modern in Häuy's works, in his preface Swedenborg also divided the ether into several aspects needed for physics. He dealt with fire, magnet, air, and water vapor. He described the declination of the magnet, the merits of British astronomer David Gregory (Gregorius) and the Cartesian vortexes around the Earth.¹²²² In the end, he added 28 tables with sketches, which was much less than in the third volume, where the closing sketches comprised nearly half of the volume.

In the second part, Swedenborg discussed iron ore and pits in Sweden, carbon in connection with fire, iron resources and silver. In the end, added a map of Siberia with Tobolsk in a folded A1 format and a picture of a blast furnace¹²²³ as later designed by Zois. In the final third volume Swedenborg described the cleaning of copper, especially in the Bohemian Lands, the melting of copper and most of all the mysterious alchemist Agrippa. Swedenborg added 89 copperplates, starting with a picture of a complete fossil skeleton from the

glacier, stone houses. He noted the archaeological tools and new lifting devices.¹²²⁴ Up to his 21st illustration Swedenborg draw the engineering tools and then continued with rocks and mining up to his last 36th illustration.

Emanuel Swedenborg studied abroad from 1712 to 1714. Between 1716 and 1747 he was a member of the Swedish Mining college. He then retired and lived as a theosophist and visionary in Sweden, Germany and England. He was a member of the Swedish Royal Academy of Sciences. In 1719, he demonstrated his invention of the rolling engine to King Charles II. In 1721, he published six physical discussions in the Latin language in Amsterdam and reprinted them in Leipzig in 1722; there he drew and described a hydraulic pump on page 101. Joseph Baader developed similar pump as Swedenborg; his ideas were used by the Frenchmen Jean-André Cazalet and by César Francois Cassini de Thury's (1714-1784) cartographer engineer Henri de Saint Michel († 1793 Munich) who mapped the areas of Bavaria between 1764 and 1770.¹²²⁵ Most of the contemporaries did not know Swedenborg's discovery. Professor of chemistry at the School of Medicine at the University of Halle, Gren, in his magazine, therefore, reflected on Swedenborg's discovery in the Latin language with pictures and his own commentary. Swedenborg's discovery was promoted by the English diplomat French writer Louis Dutens (* 1730 Tours, † 1812 London), a fellow of the RS from 1775 and a publisher of Leibniz's works.¹²²⁶ In 1847 Strutt Baron Rayleigh published a translation of Swedenborg's works in London. On January 25, 2000, in the SAZU Hall in Ljubljana, the professor Inge Jonsson presented Swedenborg's work as President of the Swedish Academy of Literature, History and Antiquities.

Most of Zois's French books dedicated to the vacuum had no extraordinary propriety entries. Among all the books which have a slightly remarkable entry that could be linked to the

¹²²² Swedenborg, 1734, 1: 294, 395, 433, 438.

¹²²³ Swedenborg, 1734, 2: 12, 88, 145, 263, table of figures I, VI, XI.

¹²²⁴ Swedenborg, 1734, 3: 16-167, 191, 301, table of figures 1, 2, 3, 7, 12.

¹²²⁵ Heilbron, 1993, 20.

¹²²⁶ Gren, 1791, 408-410.

Illyrian provinces was mainly the Latin language propriety entry "Bibliothecae lycei labacensis" in Louis-Benjamin Francoeur's (Francoeur, 1773 Paris–1849 Paris) book *Traité élémentaire de mécanique*, designed for the public instructions in its fourth Parisian edition of Bernard printed in 1807 (NUK-8511). The book was sold at bookstore of J. Klostermann son in Paris, as well as in the bookstore Klostermann son and his father in Petersburg, as we read on later glued paper on the precover. The book of A6 format was bind into a hard cardboard. Francoeur was professor of the Paris Lyceum, Examiner at Imperial Polytechnic in Paris, associate member of the Maritime department of Russian Czar, associate member of the company *d'moulton de Cambrai* and others. He was a member of the Laplace's Circle, so for his introduction he quoted a paragraph from the eighth book of Laplace's *Système du monde*. Francoeur dedicated his book to Laplace who was a senator, a member of the Imperial institute of sciences and arts and the author of the famous *Mécanique Céleste*. In his introduction Francoeur recommended for further reading of his students *Mécanique céleste*, *Système du monde*, as well as Lagrange, Monge, Prony, Carnot, Biot, Haüy, Legendre, and Puissant's works cited in the introduction.¹²²⁷ Francoeur praised Puissant's *Traité de Topographie* (1807) which was also used in the Parisian *École Polytechnique*.¹²²⁸ Francoeur divided the volume into four books of statics, dynamics, hydrostatics and hydrodynamics, which were clearly dealt with through the use of Lagrange-Laplace's analytical mechanics, at the end also supported with the variation calculus.

Francoeur determined the center of gravity by the old procedure of the Graz Jesuit Guldin. Francoeur also discussed the role of a vacuum in the alleged collision of two bodies in an empty space, a description of the barometric determination of heights and vacuum pumps.¹²²⁹ He resolved many of his puzzles with integrals,¹²³⁰ so the textbook certainly represented a hard reading for the students of the emerging French University of Ljubljana in its cradle. In the end, Francoeur inserted nine full-size images. In the middle of the

collection of images he drew some machines; he set geometric sketches at the beginning and the end, but he did not draw any Bošković's curves which most of Bošković's fans did. Bošković curve and his whole physics certainly did not have a special high place among Parisian academics.

6.7.11 Conclusion

The French lessons and its influences in the short interval of years of Napoleonic actions and failure among Slovenes underlines the development of vacuum technology on Slovenian soil. The Slovenian or, at the very least, the city of Ljubljana dependence on French sources was unquestionable. The Parisian textbooks as the best of them all in those times would be used even if they were not supported by Napoleon's bayonets. All the decades from the French Revolution to the March Revolution, we have to the great extent the French Slovenian century from Napoleon's occupation to the roaming of the French king with A. Cauchy among his suiters in Gorizia. In this spirit, we must observe the appearance of Napoleon's monument in front of Križanke in Ljubljana, besides the Polish almost only Napoleonic monument outside France, and the Bourbonic royal tomb on Kostanjevica above Gorizia with the only French crowned head buried outside his homeland. These double ties between Slovenes and Paris are just the top of the co-operation, which connects the Slovenians to the French more closely than to any other nation, which does not share the common Slovenian border.

6.8 Erberg's Vacuum-related Books



Figure 6-224: The Latin Ljubljana Lyceum propriety entry in the Francoeur's textbook from the time of the Illyrian Provinces (Francoeur, 1807 (NUK-8511)).

¹²²⁷ L.B. Francoeur, *Traité élémentaire de mécanique*, Paris 1807, Unpaginated Introduction.

¹²²⁸ R. Taton, La formation de Sadi Carnot, published in: *Sadi Carnot et l'essor de la Thermodynamique* (1976), pp. 35-56, here p. 47.

¹²²⁹ Francoeur, 1807, IX-XII, 93, 204, 440, 451, 485-503.

¹²³⁰ Francoeur, 1807, 90-91.

Table 6-21: Vacuum Techniques in the Library of Baron Jožef Kalanac Erberg in Ljubljana (1798) and then in Dol

M. Pascal. 1690. <i>Traité de l'équilibre des liqueres, et de la pesanteur de lumela de la masse de l'air.</i> Paris. 8 ^o .
Laurent Gobart S.J. 1716. <i>Tractatus de barometro.</i> Vienna. 12 ^o .
Laurent Gobart S.J. 1746. <i>Tractatus de barometro. Graecii</i> 12 ^o . ¹²³¹
Guil. Jac. S'Gravesande. 1725. <i>Introductio ad philosophiam Newtonianam.</i> Lugd. Batav. 4 ^o . ¹²³²
P. Rog. Jo. Bošković. 1763. <i>Theoria philosophia naturalis.</i> Venetis. 4 ^o . ¹²³³
Io. Beccaria. 1768. <i>Commentaries duo de phosphoris naturalis, et artificialis.</i> Graecii. 8 ^o . ¹²³⁴

6.9 Books on Vacuum Experiments in Slovenia before Cathode Ray Tubes

Among the French physicists at the Auersperg's Library, there were also two copies of the Philosophical Mathematics and Philosophical Physics of the prolific Jesuit writer Pierre Gautruche (* 1602 Orléans; SJ 1621; †1681). The Baroness Oršič read out similar books. After entering the society of Jesuits, Gautruche studied in Rennes. In 1642 and 1643, he taught philosophy at the Mont à Caen College, and then he probably moved to the college of La Flèche, once attended by Descartes. In 1653, Gautruche returned to Mont à Caen as a prefect of studies and professor of theology; he exercised both duties up to his old age in 1679. From 1668 he also taught mathematics, which was of great interest to him. In 1645, he taught his best student Pierre-Daniel Huet, the later Archbishop of Avranches 100 km southwest of Caen in Normandy; Huet's critique of Cartesians appeared after Huet visited the queen Christine of Stockholm following the unhappy Descartes death there. Huet's book used to be a popular reading among the Franciscans of Ljubljana. Wolf Auersperg did not acquire Gautruche's Philosophical Physics in the first edition of 1656,

¹²³¹ Promoted by Edition of Ljubljana rector Dillherr.

¹²³² The Jesuits of Ljubljana obtained later edition of s'Gravesande's books on Newton's physics in the year 1769, nine years after the printout in Vienna.

¹²³³ W-1418.

¹²³⁴ W-1474; NUK-8227.

but rather preferred to have five years later a Viennese reprint. Gautruche rejected the existence of a vacuum in nature, although he together with other Jesuits ensured that, of course, God can create an empty space with a miracle. He briefly summarized Torricelli's and Pascal's experiments, but he insisted on Aristotle's fear of any emptiness.¹²³⁵ He rejected astrology according to the Papal decree, and he refused the alchemy with it in the same breath. He accepted a thirty-year-old Harvey's theory of blood circulation in the bodies.¹²³⁶ Gautruche's plurality of human forms was nearer to the Franciscan Scotus than to his own religious co-brother F. Suárez.

Gautruche was the first French Jesuit who published his textbook of philosophy; the next French Jesuit Gaspard Buhon's textbook of philosophy was only published in 1723. The first edition of Gautruche's textbook was published in 1653 in his hometown Caen without any mathematical additions. Three years later he completed his work entitled the Manual of Philosophy in Mathematics as a textbook of logic, moral philosophy, metaphysics, general and experimental physics, and mathematics. He bound it with examination theses that were defended in Caen in France in 1656. In 1661, his Manual of Philosophy with Physics and mathematics was reprinted in Vienna. Wolf Auersperg obtained two copies of the Viennese edition of 1661, since he frequently visited the imperial city. He cataloged both books under several different titles in his expert group of philosophy but also in his expert group of mathematics. He addresses the first part of Gautruche's textbook with its title about physics to Auersperg's library expert group of philosophical books, while the second part with mathematical title was noted in the expert group of mathematical works. The first volume of Gautruche's textbook Handbook of Philosophical Physics was *Physica universalis*, the second *Physica particularis*, the third *Mathematica* and the fourth *Metaphysica*. The baroness Oršič also bought the same item which proves its popularity among the Carniolan high society, while many others read Gautruche's history of poetry in Carniola.

¹²³⁵ Gautruche, 1656, 1: 127-150; Brockliss, 1995, 187, 202, 212.

¹²³⁶ Gautruche, 1656, 2: 19-22, 150-155, 206; Thorndike, 1958, 7: 642-543; Brockliss, 1995, 193.

Table 6-22: The vacuum related books examined by Maria Theresa Baroness Wintershoffen married Oršič (Wintershofen, * about 1655; † after 1700)¹²³⁷ until her naughty husband has failed to obey her and accused the poor lady of the witchcraft

Number in the listing of library	Author, Title
68	Galileo Gallilei, Galileo Gallilei linceo <i>Discorsi e dimostrazioni matematiche ...</i> in 4to, Leiden: Elzevir, 1638
79	Peter Gautruche Philosophiae institutio ... Peter Gautruchio ... in 8to
79	Peter Gautruche, aureliano Philosophiae ac Mathematicae totius institutio, cum ... Authore P. Petro Galtruchio, aureliano ... in 12to, Vienna: Blaeu, 1661
88	Valerii Maximi (1 st century AD) dictorum factorumque memorabilium exempla, in 8to (also in Stična later in NUK, in Piran and Koper libraries)

6.10 Three Hundred Years since Birth of Founder of First Modern Physics-chemistry Laboratory in Area of Slovenia

Bernardin Ferdinand baron Erberg's life story ended simultaneously with the suppression of Jesuit order. A quarter of millennia ago, the local Jesuit Bernardin Ferdinand baron Erberg established the very first school experimental lab in Ljubljana. He bought the instruments and books needed to fulfil his task and patronized the republication of Musschenbroek's magnetic research produced in Protestant Leyden which indicated how the border between the Catholic and Protestant scientific pursuits were almost totally removed except for the ban on Copernicans which was removed only a dozen years later. To enable

those works, Bernardin was trained as a student of applied mathematics, prefect, and librarian in the most advanced Habsburg centres of learning in Graz, Trnava, Viennese University and the Viennese Theresianum where the labs like that already operated. Especially in his five years term as librarian in the newly established most elitist college for the sons of old nobility named Theresianum during the frequent visits of Ruger Bošković, Bernardin Ferdinand baron Erberg learned first-hand how to deal with advanced experiments of then popular optics, hydraulics, and geodesy of Bošković, as well as with electromagnetic and caloric experiments of his other colleagues. Bernardin Ferdinand baron Erberg published his own geodesic-cartographic work of Bohemia, while he left unfinished his similar description of his native Carniola in more literary sense to his first cousin twice removed Jožef Kalasanc Erberg who happened to be next to last great mind of that family name. Two years later, Bernardin wrote a great glorifying foreword to his deceased teacher's history of empress' family to prove the shift from physics-mathematical to the geographical-historical sciences of Bernardin as the librarian assistant of the great newly established library of Theresianum college. The move which is hardly understandable from the point of view of modern specializations was completely in the agenda of the Jesuit unprofessional approach to the several different branches of sciences in the same time based on the holistic model of the best Jesuit being at home in all sorts of knowledge resembling the last man who knew everything, the Roman Jesuit A. Kircher. The newly developed Jesuit sciences of numismatic, architecture, or Ruger Bošković' applied mathematics represented a different type of Jesuits whose primary goals were the narrower parts of mathematical sciences, which more resembled the mainstreams of Paris or London.

Bernardin Ferdinand baron Erberg's closest family members were equally successful Jesuit experts for applied mathematics which smoothed his networks worldwide. Bernardin's first cousin and his nephew were among the most eminent missionaries in America and Beijing which the Jesuits ever produced. But their best time were over after the suppression of Jesuits soon after Bernardin's death.

¹²³⁷ ARS, SI_AS 309, Legacy Inventory archive, fascicle 39, technical unit 78, litera O, no. 10, p. 68; Štuhec, 1995, 90.

The lion's share of the Erberg's writings was created under the goose pens (quill pen) of the cousin of the Jesuits Anton and Bernardin Ferdinand baron Erberg (* 10. 5. 1718 Ljubljana; † June-August 1773 Krems), namely by their uncle the Capuchin turned Protestant Matija Erberg. These prominent figures were just the top of a literally extremely efficient generation, which gave to Carniola many great scholars. Knowledge became a hobby and, at the same time, a profession of the barons Erbergs, whose scientific curiosity was almost endless. Erberg's writings dominate the exact sciences and law. With their almost singular exception of the Protestant Matija, they published a bit of theology, and almost nothing in medicine with the only exception of Erberg's student manuscript on physiology. Just Matija published economic or even agricultural files among Erbergs, whose physics had been very famous in their days. The successful rearrangement of gardens at Dol manor of Joseph Kalasanc Erberg enabled his discussion of the management of Dol horse chestnut, which was communicated to the Viennese magazine.

6.10.1 *Graz and Viennese Applied Mathemaatics*

After his master's degree in philosophy. B. F Erberg taught grammar in Ljubljana in 1740/41. It was great to be home again and to meet all those old good friend and relatives. In 1741/42 in Graz B.F. Erberg, Anton Bosizio, Franz Xaver Haller, Ignaz Rasp, Joseph Liesganig as their bidellus (bedel) and Michael Klaus specialized their first year of applied mathematics with Erasmus Frölich. The professor of physic was Halloy, Joseph Zanchi taught mathematics, Joseph Erberg studied his 4th last year of theology, Anton Erberg was professor and dean of Theology, Ernst baron Apfaltrer was a dean of linguistic,¹²³⁸ Karl Dollenz taught logic, Karl Andrian (Adrian, 1680 Trident-February 7, 1745 Graz) was professor of history as a dean of philosophical faculty and writer of the local history of Graz college, while the rector Willibald Krieger was appointed on 11. 5. 1740.¹²³⁹ During his specialization of mathematics called the repetition, B.F. Erberg obviously also attended Andrian's lectures of history as he recalled and noted later in 1762.

¹²³⁸ Andritsch, Matrikeln 1711-1765, 181.

¹²³⁹ Catalogus 1742: 10-11.

In 1742/43 in Viennese university the same class of students including B.F. Erberg, Anton Bosizio, Franz Xaver Haller, Ignaz Rasp as their bidellus, Joseph Liesganig and Michael Klaus specialized their second year of applied mathematics with Erasmus Frölich who was additionally also prefect of mathematical museum and the first confessor. In Catalogus¹²⁴⁰ they were usually noted as *Repetentes Matheseos* specializing the applied mathematics with no indication that they also specializing math in their second year. In Graz in the previous year B.F. Erberg also listened to the lectures of history, while in 1742/43 the Viennese university had a special class of three *Repetentes Historiae* where they employed Ignaz Wagenseil, Josephus Wibmer as their manductio (guide) for participating in the celebration of the Eucharist, and Mathias Köberer. The professor of mathematics and operarius was Paul Wimmer, while Hingerle from Ljubljana was still rector. Anton Hallerstein from Carinthia branch still taught controversial theology, Jacob Focky taught physics, Joseph Franz was professor of observational astronomy, while Sigismund Calles was professor of history and home confessor, probably also the head of historical specializations of his three students.

6.10.2 *Graz for Ph.D.*

B.F. Erberg practice between master's in philosophy and beginning of his Ph.D. Studies in theology was unusually long as it lasted for five years while most of other guys made that stuff in just two years. After he finished his specialization, B.F. Erberg additionally taught the syntax as the highest class of grammar in Graz in 1743/44.¹²⁴¹ In Graz in 1743/44, B. F. Erberg's colleagues were professor of mathematics Halloy, the lecturer of principles Mathias Rieberer (1730 Murau of Upper Styria-1794 Regensburg) who taught physics in Ljubljana and published his exam theses of physics in 1758 noted in *Historia Annua* pp. 312-313 as *Tentamen ex physica, logico-metaphysica et mathematica ad praescriptum regionum dectretum tenorem habita*.¹²⁴² He also published *Gramatica Hebraica* in Graz in 1755, *Manuscripta diplomatica* in Vienna, and *Novissima Europeae I*, 1794, He continued the works of Marko Hansiz and the lecturer-professor of poetry Andrej Friz

¹²⁴⁰ Catalogus 1743: 28-29.

¹²⁴¹ Catalogus 1744: 10.

¹²⁴² Sommervogel, VI, 1890-1900; Stöger, 301.

Table 6-23: Kepler's books left in Janez von Pučar's legacy upon his death in 1650; 1243 his collection was inherited by the lawyer dr. Franc von Ott (Otto), the owner of Lower Carniola (Dolenjska) manors Svibno and Maténa, and Roženbah near Veliki Lipljeni south of Škofljica.¹²⁴⁴ Ott's 189 books were listed in his legacy inventory on p. 62-75.

Page / number in the Catalogue list	Author	Title in Ott's legacy inventory (in Pučar's legacy inventory)
103 (Pučar) 67/80 (Ott)	Johannes Kepler	Nova Stereometria doliorum vinariorum Joannis Kepleri in folio (in Pučar's library noted as: Joannis Keppleris in weisen Pergament in folio Buch 1)
111 (Pučar) 67/86 (Ott)	(Kepler)	No 86 tabula Rudolphina in folio, without notification of the author Kepler (in Pučar's library noted as: Joannis Keppleri Buech so noch mit eingebenden Buch 1)

Table 6-24: Designer of vacuum balloon Francesco Lana Terzi (* 1631; SJ; † 1687) in Carniolan libraries

Title of Lana's work	Carniolan owners
1670. Prodomo ovvero saggio di alcune invenzioni nuove premesso dell'Arte Maestra. Brescia	Auersperg in Ljubljana; Jurij Andrej Triller Count Trilek (1663-1701) in the castle of Ribnica ¹²⁴⁵
1684, 1686, 1692. <i>Magisterium Naturae et Artis. Opus Physico-Mathematicum</i> . I-III Brescia, Parma: Ricciardi (NUK-8461).	Ljubljana Jesuits; SKLJ; Valvasor owned just first two volumes published in 1684 and 1686
1724. Placita Physica de sympathia et antipathia depromta ex Franc. De Lanis S.J. Honoribus. - dicata. Viennae: Wolfgang Schwendimann (W-1531; NUK-8297; FSLJ-20 f 53).	Škerpin's purchase for the Franciscans of Ljubljana

Table 6-25: Kaspar Schott's (Gaspar, * 1608 Königshofen near Würzburg, SJ 1627 Würzburg; † 1666 Würzburg) books about vacuum in Carniola

Year of issue	Title	Carniolan owner
1671	<i>Gesellschaft Japu</i> of Arnoldus Montanus bind to Schott, Gaspar's <i>Magia optica...</i> 4 (1 st part <i>Magia Universalis Naturae et Artis</i> . 1671 Bamberg: Joh. Martin Schönwetter)	21/83 98 ^v Stična
1662	Physica curiosa, 1-2, Herbipli, 4 perg. (Parchment) White. (each part recorded separately)	276, secular history; 369; Auersperg
1667	... <i>Physica curiosa</i> ... Herbipli: Endter	Valvasor
1664	Technica curiosa sive mirabilia artis, Herbipli, 4 perg. (Parchment) White.	376, linguistics; 370; Auersperg
1657	Magia universalis naturae et artis, Herbipli. 4 perg. (Parchment) White (two copies)	377, linguistics; 367; Auersperg
1659-1677	... <i>Magia universalis naturae et artis</i> ... 1 Pars I. Optica, II. Acoustica, III. Mathematica, IV. Physica, Bambergae: Schönwetter	Valvasor owned volumes 1, 3 and 4
1661	Cursus mathematicus. Herbipli (Würzburg)	-; 366; Auersperg
1657-	Mechanica hidraulico pneumatica. 4 perg (Parchment): White. Herbipli:	388; 368, 2: 360

¹²⁴³ ARS, SI_AS 309, Legacy Inventory archive, fascicle 34, technical unit 81, litera P, no. 29-42, here no. 32, p. 68.

¹²⁴⁴ ARS, SI_AS 309, Legacy Inventory archive, fascicle 39, technical unit 77, litera O, no. 1-8, here no. 2, p. 64; Štuhec, 1995, 90.

¹²⁴⁵ Inventarium uber wailandae vollgebornen Herr Herr Graf Georg Andrej Triller von Trilleck (ARS, SI_AS 309, Legacy Inventory archive (Zapuščinski arhiv), fascicle 46, technical unit (Tehnična enota) 114, litera T, no. 25a/Ribnica, page 155-206), page 158, number of book 16 (*L'arte Maestra del padre Francesco Lana Jesuita*); Štuhec, 1995, 90.

1658	Pigrin (bind to Guericke's <i>Experimentum novum Magdeburgicum</i>)	Auersperg; Valvasor
1661	<i>Cursus mathematicus, sive absoluta omnium mathematicarum</i> . Herbipoli: Schönwetter (S; KSSKL-Loka T 1). Reprints: 1674. Francoforti: Cholin; 1699. <i>Cursus mathematicus, sive absoluta omnium mathematicarum</i> . Francoforti ad Moen: Schönwetter (NUK-4217 Jesuitical bookplate). ¹²⁴⁶	1699 Capuchins of Škofja Loka
1663	Arithmetica practica generalis ac specialis; ex cursu mathematico ejusdem Auctoris extracta, atque correcta, et haec secunda editione in usum Iuventutis mathematum studiosa proposita. Herbipoli (Würzburg): Hertz. 8°. (NUK-4111).	Erberg, No. 56
1663	... Anatomia physico-hydrostatica... Herbipoli: Schönwetter	Valvasor
1677	<i>Cursus mathematicus</i> ... Bamberg: Joh. Martin Schönwetter	Valvasor
1677	<i>Magia Optica</i> ... Frankfurt: Schönwetter (Jesuitical German translation of <i>Magia universalis naturae et artis</i>)	Valvasor

Table 6-26: Published and manuscript works of the member of Erberg family

Name of Erberg	Year	Place	Title	Field
Janez Danijel	1671	Vienna	<i>Disputatio juridica de Officio Iudicis</i>	Law
Janez Adam	1687	Graz	<i>Conclusiones ex Universa Philosophia</i>	Philosophy, Physics
(Janez) Matija	1699	Nurnberg	<i>Christliche Labung oder frisches Trostwasser gezogen aus den Brunnen der Augsburgischen Confession</i> ¹²⁴⁷	Theology
(Janez) Matija	1703	Nurnberg	<i>Scherzi Historici (Kurzweilige Historien zum Exponieren)</i> ¹²⁴⁸	Theology
(Janez) Matija	1703	Nurnberg	<i>Corriere tornato dal Parnasso: in rame, rime (zurückgekommene Courier vom Berg Parnasso)</i> (Uršič, 1975, 80)	Poetry
(Janez) Matija	1702	Nurnberg	<i>Monatlicher Italiänisch teutscher com(m)issions und Factor Spiegel</i> ¹²⁴⁹	Economy
(Janez) Matija	1702, 1710	Nurnberg: Endter	<i>Le Grand Dictionnaire universel et parfait divisé en trois langues, savoir Italien, François, Allemand (Il Gran Dizionario Universale & Perfetto)</i> ¹²⁵⁰	Vocabulary
(Janez) Matija	1703	Nurnberg	<i>Grammatica a la moda Tedesco-Italiana a prò dei principianti</i> ¹²⁵¹	Grammar
(Janez) Matija	1704	Nurnberg	<i>Guldener Bibel-und Jesus-Schatz/Der Auserwehlten Kinder Gottes</i>	Theology
(Janez) Matija	1705	Nurnberg	<i>Neu-eröffnetes Handels-Contor und Neu-aufgeschlossenes Handels-Bewölb: in deren Erstem Allerhand Kauffmans-Brieffe</i>	Economy
Janez Ernest	1709	Ljubljana	<i>Exercitium Mathematicum, Sive Paradigma Catoptrico-Steganographicum</i>	Physics-optics (exam)
Volbenk Adam	1709	Ljubljana	<i>Conclusiones proemiales de natura et objecto logicae</i>	Logics (exam)

¹²⁴⁶ Benedik, 2008, 190.

¹²⁴⁷ Uršič, 1975, 79.

¹²⁴⁸ Uršič, 1975, 80.

¹²⁴⁹ Uršič, 1975, 61.

¹²⁵⁰ Uršič, 1975, 61.

¹²⁵¹ Uršič, 1975, 80.

(Janez) Matija	1712	Nurnberg	<i>La Sacro-Santa Biblia in lingua italiana</i> (Uršič, 1975, 80, 181)	Theology
Jurij	1713	Linz	<i>Assertiones ex tractatus de legibus</i>	Law (exam)
Jurij	1713	Linz	<i>Fasciculus rubricarum utriusque iuris</i>	Law
Janez Benjamin	1716	Ljubljana	<i>Anathema Astronomico-Sciathericum</i>	Physics-optics, Astronomy (exam)
Innocent	1727/28	Paraguay	Atlas	Geography
Anton	1728	Graz	<i>Topografia ducatum Styriae</i> ¹²⁵²	Geography
Anton	1728	Graz	<i>Topografia ducatum Carinthiae et Carniolae</i>	Geography
Anton	1730-31	Vienna	<i>Discussio peripatetica, in qua Principia philosophiae Cartesianae principia per singula fere capita</i>	Philosophy
Anton	1730	Vienna	<i>Annus salutis... Promotore P. Ant. Erber</i>	
Anton	1731	Vienna	<i>Metamorphosis poesis ... Promotore P. Ant. Erber</i>	Poetry
Anton	1734	Vienna	<i>Panegyricus D. Catharinae Virgini et Martyri dicatus</i>	Theology (exam)
Anton	1736	Graz	<i>Dissertationis Phediopicae de Cancolius oecumenacis</i>	
Anton	1739	Graz	<i>Epitome contraversiarum religionem</i>	Theology (exam)
Anton	1738/39	Graz	<i>Tractatus de Poenitentia Extrema Uctione Ordine & Matrimonio</i>	Marriage
Bernardin Ferdinand or Jožef Kalasanc	Around 1738/39 or in late 1790s	Vienna?	<i>Physica</i>	Physics, Physiology (manuscript of student of physics)
Anton	1747-1748	Vienna	<i>Theologiae speculativa tractatus</i>	Theology
Anton	174?		<i>Dissertationes Theologico historico Criticae</i> (Uršič, 1975, 112)	Theology
Anton	1750	Vienna	<i>Institutiones Dialecticae</i> (reprints in Trnava 1752, 1761)	Philosophy
Anton	1750, 1751	Vienna	<i>Cursus Philosophicus</i>	Physics, Philosophy
Bernardin Ferdinand	1754	Ljubljana	<i>Assertionibus ex universa philosophia</i>	Physics in Philosophy (exam)
Anton		Vienna?	<i>Jus naturae in Jus canonicum</i> (manuscripts)	Law
Bernardin Ferdinand	1760	Vienna	<i>Notitia illustris regni Bohemiae scriptorum geographica et chorographica</i> (he did not finish his similar work focused on Carniola which later finished his relative Jožef Kalasanc Erberg)	Geography
Bernardin Ferdinand	1762	Vienna?	<i>Epoch. Habsburg</i>	History
Bernardin Ferdinand	1764?	Vienna	Res gestae ac scripta virorum S. J. Prov. Austr Ab a. 1551 ad 1764 (Viennese national library, manuscript 975).	History
Jožef Kalasanc	1806/07	Vienna	Paper on horse chestnuts ¹²⁵³	Farming in Dol Manor
Jožef Kalasanc	1825	Dol	<i>Versuch eines Entwurfes zu einer Literatur-Geschichte für Krain</i> (Manuscript, published in 1980s)	History

¹²⁵² Uršič, 1975, 148.

¹²⁵³ Kidrič, 1926, 165.

(1711 Barcelona-1790 Gorizia) who later promoted books of Gaston Pardies and spent his last two decades as the ex-Jesuit professor of mathematics in Gorizia. In 1741 he translated from French: *Dissertatione de cognitione bruturum* of Gaston Pardies SJ = *Cognitionem brutorum*. The same item was promoted by Friz and Grubanovicz in Graz in 1741, and by Koller in Vienna.

The other B.F. Erberg's colleagues in Graz were Karl Dillherr (Dillher) as the professor of logic, Anton Vorster of physics, Karl Dollenz of metaphysics, B.F. Erberg's first cousin Anton Erberg as university canceller librarian reviser, dean of literature-linguistic and prefect of law exams while the rector Udalrik Bombardi was appointed beforehand. Five B.F. Erberg's students of syntax in Graz¹²⁵⁴ were Joannes von Arbesser (* Hadersfeld northwest of Vienna in Austria), citizen Anton Bredlin from Gezen in Tyrol, Franciscus von Egger from Graz, citizen Joseph Haubenwaler from Vorau (Voraviensis) in Upper Styria and the commoner Johannes Baptist Regale from Sarnthal (*Sarentino*) in South now Italian Tyrol. No student to talk with him in Slovenian language as B.F. Erberg was sorry to find out.

After Graz, B.F. Erberg taught poetry inside the studies of humanities in Gorizia in 1744/45.¹²⁵⁵ His rector was Joseph Tedeschi newly appointed on 21. 1. 1744, Anton Terzi and Joseph Zanchi of Rijeka taught casuistic, Franciscus Conti taught physics and metaphysics, Franciscus Vittinich taught logic, Joseph Carina was professor of the rhetoric and the future leading Viennese architect of Italian origin Anton Batista Izzo (1721 Košice-1793 Vienna) taught grammar. Izzo and B.F. Erberg were later again colleague in Theresianum where Izzo taught in the newly established chair of architecture and published his books in 1764-1769, including: *Tractatus de Pyrotechnica Balistica* in Vienna in 1766, *Elementa architecturae Civilis et Militaris* in Vienna in 1764-1765 with reprints up to 1777 in French translation of the Pater Jesuit Bossicart (Bossicar, Nicolaus * 1739) who served as the professor of French language in Viennese Theresianum in 1772. Izzo also published *Elementa Geographiae* in Vienna in 1769.

¹²⁵⁴ Andritsch 1711-1765, pp. 192, 194.

¹²⁵⁵ Catalogus 1745: 9.

In 1745/46¹²⁵⁶ among B.F. Erberg's Classmates in Graz during his first year of theological studies were future professor of physics the Carniolan Maximilian Morautscher (1721-1806) as the son of Auersperg's manager from the castle-manor Mala vas as a part of Knežja vas in modern mayordom of Trebnje of Lower Carniola, later Zagreb physicist Franc Dabrović (1720 Požega-1767), Anton Angerer (1720-1802 Linz) as the prefect of philosophic-humanistic-controversial studies. Udalric Bombardi was still the rector appointed on 24. 11. 1743. Karl Dillherr taught metaphysics, Anton Gallyuff canons, Franciscus Grafflinden taught theology, Joseph Maister taught mathematics, Joseph Kössler taught physics, Ignaz Schreiner taught casuistic, Leopold Morelli taught sacred scripts, Joannes Priletzki taught controversy, Halloy was a prefect of astronomical observatory (Spec.) and mathematical museum, the former Ljubljana professor Sebastian Stainer monitored the exams.

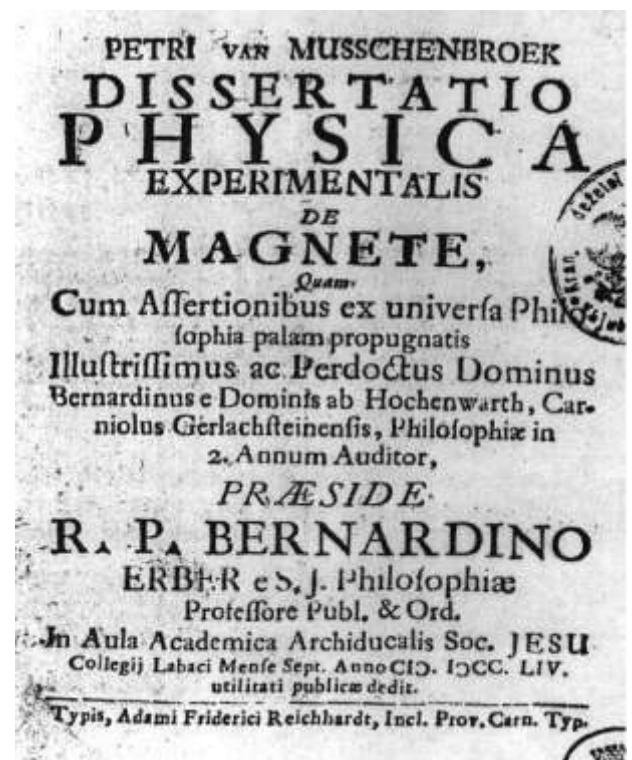

Figure 6-225: B.F. Erberg's and his student B. Hohenwart's exam bind to promotion of Musschenbroek's research if magnetism in 1754.

6.10.3 Judenburg Probation

In 1749/50, B.F. Erberg in his 31st year entered the final stage of his Jesuit education with his third

¹²⁵⁶ Catalogus 1746: 10.

final probation year in upper Styrian Judenburg. He gave his feast of vows including the eternal mobility which he never endorsed as he officially never left the border of the areas of Austrian Jesuit province.

In Judenburg, B.F. Erberg's classmates among the paters of the Third Probation included his old friends later Ljubljana professor of physics the Rijeka native Franc Tricarico, Biwald's teacher of mathematics Joseph Apponyi (1718-1757) with his leading textbook,¹²⁵⁷ their manductio Anton Bosizio, Franc Dabrović, the astronomer Franc Weiss, and Ignaz count Rasp. Their Judenburg rector was Paul Zetlacher appointed on 27. 12. 1746 with his minister B.F. Erberg's Ljubljana compatriot Daniel Valvasor.



Figure 6-226: B.F. Erberg's botanic gardens of Theresianum in 1756 with dedication to his students Johan Josef Franz Berthold Schaffgotsch (17th October 1741-1806) and his half-brother Franz de Paula Ernst Schaffgotsch (27th December 1743 Horní Maršov- 1809 Prague) published before title page of his *Notitia illustris regni Bohemiae scriptorum geographica et chorographica*, Vienna: Joseph Kurtzböck, 1760

There was no teaching in good old Judenburg, just prayers and subterranean fights for future great jobs and positions. B.F. Erberg finally achieved his goal except for his dreamed missions. He was chosen to reform the exact part of Ljubljana studies in accordance to his late first cousin Anton

¹²⁵⁷ Losada Prada, Keri, Apponyi, 1752, 1753-1754. As Keri and Josef Apponyi's promotive works published with Mitterpacher de Mitternburg and Kery (Keri, Sommervogel, 1890-1900, 1: 479) primary as the work of Salamanca professor Losada.

Erberg's textbook modified by G. van Swieten's new Theresian reforms.

6.10.4 *Ljubljana Lab: Bernardin Ferdinand Erberg Reforms the Physics Lecturing in Ljubljana*

In Ljubljana in 1757/58 (Catalogus 1758: 15-16) B.F. Erberg taught mathematics and wrote the diary of the college while Franciscus Tricarico taught physics, Ernst baron Apfaltrer headed the seminary, Kart Dillherr was the prefect of higher school as lecturer on casuistic, Anton Maisterr was prefect of Lower School, Joseph Erberg taught casuistic, Mathias Riebertd taught logic and metaphysics, Moraučer was procurator and old rector Sigismund Lichtenberg was the first confessor, the future Graz physicist Leopold Biwald taught rhetoric, Anton count Hohenwart lectured on poetry Francis Weneg taught syntax, and Joseph Carl was rector appointed in 26 4. 1745.

6.10.4.1 Organization of the Ljubljana Physics-Mathematical Cabinet

Erbergs helped Empress Maria Theresa in modernizing Ljubljana's higher studies. A week before the birth of Jurij Vega on 16. 3. 1754 for the purchase of instruments they earmarked the sum of 500 florins, almost half of the annual income of Dol manor.¹²⁵⁸ The census of fifty-one (in fact fifty-five) unnumbered devices for physics-mathematical experiments of Ljubljana Jesuit philosophical studies was compiled by professor of mathematics and physics Bernardin Ferdinand Erberg on 17. 9. 1755.¹²⁵⁹ With the annual grant of the physics cabinet 25 florins B.F. Erberg could have bought two or three new instruments every year if those gold coins were not used to maintain old devices. In 1767, after B.F. Erberg's departure the new metal casting manufacturer Jakob Samassa took care of the repair in the physics cabinet of the Jesuit college in Ljubljana, when Samassa's friend Gruber came to Ljubljana.

Erberg listed the instruments by the sectors in which they were supposed to serve. He considered

¹²⁵⁸ *Historia annua*, 1754, 284; Smole 1982, 135.

¹²⁵⁹ Müllner, 1901, 171-172; Schmidt, 1963, 1: 303; SI_AS 6, Komora in reprezentanca (Chamber and representation), Fasc. 40, 17 September 1755.

the individual parts of mechanics as separate units. The census started with gadgets for astronomy, followed by mathematical instruments, a collection of tools for measurement, tools to show magnetism, geodesy, acoustics, gases, heat, mechanics, optics and electricity. Only a few devices were listed outside of this order, which did not exactly follow the sequence of physics lectures in higher studies.



Figure 6-227: B.F. Erberg’s map of Prague areas published at the end of his *Notitia illustris regni Bohemiae scriptorum geographica et chorographica*, Vienna: Joseph Kurtzböck, 1760

If mechanical instruments also include acoustics, B.F. Erberg’s list included twenty-four, that is, almost half of the teaching materials for mechanics. Many facilities for the exploration of light indicate that Newton’s work from the years 1672 and 1704 and his optics became the most important experimental science. In addition to devices for displaying the laws of geometric optics, they acquired four microscopes, prisms and cones. Many microscopes certainly proved B.F. Erberg’s interest in biology, also indicated by his alleged manuscript that compares the operation of the eye and the camera.¹²⁶⁰

Among the first astronomical devices in the Jesuit college in Ljubljana, they acquired an armillary sphere (*Sphaera Armillaris*) in 1706. Bernardin

¹²⁶⁰ SI_AS 1073. Collection of manuscripts 242 r: Erberg, about 1740, 58.

Ferdinand Erberg supplemented the collection with two globes and a stellar atlas. The Ptolemaic model has already been completely abandoned, since Bernardin Ferdinand Erberg acquired the model of the universe only by Tycho and Copernicus’s system. In doing so, he bravely hurried a bit, as he bought them two years before the Catholics were officially allowed to teach Copernicus’s presumption. So, was really a little premature, but with enough caution because Ljubljana was far enough for Roman headquarters.

Table 6-27: Devices on the Jesuit College in Ljubljana according to Erberg’s census on 17 September 1755

Branch of Science	Number of devices
Mathematics	2
Mechanics	24
Solid state permeability & cohesion	6+2
Tools for measurements	2
Fluids	4
Acoustics	1
Geodesy	3+1
Vacuum, overpressure, gases	8
Optics	13
Astronomy	7
Heat & Meteorology	2
Electricity	1
Magnetism	1
Total	51 (54)

In college they probably purchased a telescope before the year 1761, when J. Schöttl in Ljubljana observed the transit of Venus across the face of the sun with his sixteen feet long binocular. The measurements of the Jesuit surveyors were encouraged by B.F. Erberg with his acquisition of geodetics tools in Ljubljana in 1755. Calculation of the length of the meridian has become a kind of parade horse of Jesuit scientists. In the Slovenian part of Styria, the meridian was measured by the Jesuit Liesganig, who also taught Gabriel Gruber. Of course, B.F. Erberg knew the triangulation, with which his first cousin Innocent Erberg and Innocent’s nephew A. Hallerstein helped to draw down the maps of South America and of the Far East. In the beginning of April 1757 and again on 9 March 1758, Bošković himself visited Ljubljana just before B.F. Erberg’s went to Theresianum. Bošković explained to Carniolan folks the new

principles of experimental teaching and geodetic measurements at territories of the Papal States, which made him famous during the years 1750-1756.¹²⁶¹ At the time of B.F. Erberg's purchases of experimental experiments in Ljubljana the electricity and magnetism were still the marginal branches of physics, more suitable for the appealing popular display of exceptional phenomena, than for the useful physics way of thinking. In 1755, the special devices for the study of magnetism and heat in Erberg's collection did not yet exist, except insofar as they were needed for geodetic and meteorological research. Magnetism played a peripheral role until the magnetic force was measured at the end of the 18th century. In Erberg's census from 1755 we miss the models of steam engine, particularly economical steam digester as the forerunner of the pressure cooker under high pressure, in which the Frenchman Denis Papin cook a festive lunch for the King of England in 1680. In 1755 Erberg in Ljubljana brought the whole facility to demonstrate the resistance of the air, gravitational force and laws hydrostatics. He devoted eight tools to research vacuum, pressure and air resistance, as these questions obviously inspired his curiosity. He pumped out the air with the air pump probably manufactured by Musschenbroek in Leyden and convinced his students that sound could not pass through an empty space, but the thermal radiation and light could. Robert Boyle proved that fact a century ago; Erbergs in Dol manor already thermal were already aware of that since they could borrow a complete collection of Boyle's books from the library of their friend Valvasor at Bogenšperk. B.F. Erberg also bought the Magdeburg hemispheres of Boyle's friend and rival Otto Guericke for the Jesuit lessons in Ljubljana, along with a device to illustrate Galilean's assumptions about movement in an empty space. Both century old experiments were a real attractions for the eyes of the pupils. Of course, Erberg only demonstrated his experiments to his student boys ex cathedra, as he did not have enough tools for the pupils' independent experimenting. In 1755, B.F. Erberg began to use three scales in the Jesuit College of Ljubljana, among them 'sGravesande's and hydraulic. Precise weighing in the Lavoisier Parisian Laboratory shortly after Erberg's death enabled the advancement of chemistry. Similar devices were purchased by the Jesuit Orlando (1723-1784) in Trieste gradually from 1753 until the ban of the

Jesuits two decades later. Orlando studied philosophy in Graz when B.F. Erberg taught grammar there, so they knew each other very well and exchanged their experiences of experimenting and pedagogy.

6.10.4.2 Bernardin Ferdinand Erberg Updates the School Library

B.F. Erberg arranged his Ljubljana Physics Cabinet primarily in Paris and Leiden patterns. He was aware that the new experimental devices would not be enough. The devices needed instructions for their use. In 1754, just prior to the acquisition of instruments, B.F. Erberg has bought much more modern mathematical and physics works compared to his predecessors, including Ozanam's instructions for entertaining experiments (1723), Musschenbroek's research with the addition of pneumatic devices (version of 1739), the first part of Désaguliers' experimental physics (version 1751) and five volumes of German translations of the Parisian Academicians' publications from 1692-1715 printed in Wroclaw in 1748-1750. In hat Parisian notes B.F. Erberg checked the findings of astronomers Cassini, Philippe de la Hire (* 1640; † 1718), René-Antoine Ferchault de Réaumur (* 1683; † 1757), Amontons, and Swiss Johann Bernoulli (* 1667; † 1748). Their works were classified according to their observed topics in Parisian academic journal. In the same year, B.F. Erberg bought at least two other Musschenbroek's Latin books and even reprinted-promoted Musschenbroek discussion on magnetism in Latin translation in Ljubljana. B.F. Erberg wrote all his other works in Latin, with the only exception of the German student manuscript on physiology from the lectures of his paternal first cousin Anton Erberg in Vienna in 1738/39 if that were not the later Jožef Kalasanc Erberg's notes.¹²⁶²

When complementing the Jesuit library, Bernardin Ferdinand Erberg was inspired by the richly equipped collections of his relatives Erbergs, who subsequently merged their libraries in the Dol Manor. Despite the modernization of Bernardin Ferdinand Erberg, in the library of the Ljubljana college still dominated mathematical works of Jesuit writers like Dechales, Tacquet, Schott,

¹²⁶¹ Marković, 1968, 320-321.

¹²⁶² SI_AS 1073, Collection of Manuscripts , 89 r, (178 r), 242 r.

Gooden, Steinmeyer, Federico Sanuitali, Hell, Wiedeburg, Mario Bettini, Frölich and Roman professors Clavius, Kircher and Bošković. They still insisted on geometric derivations, although a more modern infinitesimal calculus was increasingly popular. The Jesuits of Ljubljana acquired five books with dated propriety entries upon the beginning of their lesson of mathematics at a higher level between 1706 and 1709. Most of them were purchased by Bernardin Ferdinand Erberg during his course of reforms in mathematics classes between 1750 and 1758 when he taught mathematics and physics in Ljubljana. Initially, the Jesuits procured only Latin books until Erberg began purchasing newer works written in the living vernacular languages. At seven mathematical-physics and astronomical books, B.F. Erberg's bookplate explicitly stated the year of purchase (Wolff 1733, Ozanam 1723, Wiedeburg 1726, Bošković 1755, Hire 1725 Manfredi 1750, Marinoni, 1745), while in the other thirteen mathematical and astronomical books he did not (Wolff 1756, Genovesi, Gooden, Musschenbroek, Magalotti, Ritter, Clavius, Lana, Brixianus, Sanuitali, Copernicus, Reinhold and Commandino bind to Kepler). In the middle of the 18th century, B.F. Erberg acquired altogether forty-two books on the exact sciences, but he was not their only user, since the name of I. Redlhamer (1719 Erlauf-1794), who used to lecture on physics in Ljubljana in 1755/56, was written on the cover of Vater's Experimental Physics. At the end of the lectures, Redlhamer conducted a public examination of candidates with an experimental presentation of 160 different physics and mathematical queries. The event was a real treat for the eyes, as among the educated listeners the Jesuit scribe counted thirty counts and barons, among them certainly also the folks from Dol castle. The performance ended with a symphonic concert and a theater, and their examination questions were printed in Trieste.¹²⁶³ The book of Christian Vater (1651-1732), *Physica experimentalis systematica in usum studiosae iuventutis*, Witebergae, 1734¹²⁶⁴ got a bookplate: Ex. Liberales artes P. Ignat. Redlhamer Inscriptus Bibl. Phil. Coll. Labac S.J. 1755. The Wittenberg physician and university professor Christian Vater was a father of anatomist-botanic Abraham Vater (1684 Wittenberg-1751 Wittenberg).

¹²⁶³ Historia Annua, 300-301.

¹²⁶⁴ Wilde's catalogue no. 1465; NUK-8306; 1775 inventory NUK manuscript manuscript 31/83, J) no. 21.

Erberg donated many learned books in parchment covers to his Ljubljana college. Thus, the label signed Ozanam's work beyond the headlines read that Councilor court chamber in Vienna Ljubljana native Franc Henrik (Joseph) baron Raigersfeld (* 1697, † 1760) bestowed that book upon Viennese mathematics student B.F. Erberg on of 9. 6. 1743. Donor F.H. Raigersfeld was closely connected both with the Erbergs and the Jesuits. On 10 June 1726, he married Maria Anne Elizabeth Erberg (* 1710; † 1752). The bride was the daughter of B.F. Erberg's cousin, Baron Franc Michael Erberg (* 1679; † 1760), a member of the Provincial Court of Carniola. Maria Anne's fourth son, the Jesuit Franc Borgia Karel (* 1736; SJ 1752; † 1800), was professor of history at the Theresianum between 1767-1773, initially under the new prefect B.F. Erberg. Maria Anne's youngest son, Michael Raigersfeld, was right then considered the most talented student at the Theresianum of Vienna. Probably B.F. Erberg mastered French, but he did not read Dutch or English, which were also represented among the books of the Jesuit library in Ljubljana. He also bought a letters of the Secretary of Florentine Academy Magalotti, Italian books of Della Torre and Nollet, so he must have read Italian. In the 1750s, B.F. Erberg wrote nearly half of the Jesuit propriety entries on the cover of books written in the later dominant Newtonian and Musschenbroek's orientations, which he also obtained from Musschenbroek's (Protestant) Leiden. He might find new astronomical literature in Nuremberg, but he bought a lot of items in nearby Venice and in the city of Brescia. He acquired a relatively few books in Rome, which until then was the main provider of textbooks for Jesuit schools. Most of Erberg's books went beyond the textbook level, as they focused on specific issues and were equipped with modern descriptions of measurements and experiments. Ozanam's manual, which Raigersfeld donated to Erberg, draws from the typical Parisian tradition of entertaining mathematics and physics developed just before the ideas of Ozanam's coeval Newton prevailed in France. Ozanam published four parts; Raigersfeld took his time and wrote down dedications for B.F. Erberg in all four of them. The text contained a total of 1,672 pages full of instructions for experiments, which the professor should indicate to students. The first part of the book dealt with arithmetic, geometry, music and optics, the other with sunshine, cosmography and mechanics, the third with pyrotechnics and

Table 6-28: B.F. Erberg's purchases of the physical, mathematical and astronomical books with today preserved dated propriety entries in the former Jesuit library which today belongs to NUK (the authors of mathematical and astronomical books are noted diagonally, writers of Erberg's own seven manuals are bold. In the brackets are abbreviations used for the place of author's residence, if different from the city of the printings: Ne-Naples, Pe-Petersburg, Ri-Rome, Fi-Florence, Lo-London, Lz-Linz. Pe-Pesaro, Pr-Prague, Du-Vienna, Gr-Graz, Tr-Trnava, L-Ljubljana, Je-Jena, Nü-Nurnberg, Tü-Tübingen, Wi-Wittenberg, Le-Leipzig, Gö-Göttingen, Fr-Frankfurt, Ha-Halle, Ma-Magdeburg, Wr-Wroclaw (Breslau), Ly-Leiden, Li-English Jesuit College in the Belgian Liège, Že-Geneva, Ba-Basel; UG-textbook of geography, UF-physics textbook ; UM - textbook of mathematics, UA-textbook of astronomy, UP-textbooks and other instruction manuals, IT-exams in physics, OP-optical experiments with microscopes, AT-astronomical tables, devices and atlases, EP-electric experiments, GM-geodetic measurements, MM-meteorological measurements; PG-against Galileo, Copernicus, together with the Wittenberg-based agnostic interpretation of the Earth's motion, ZG-For Galileo, PF-against Franklin, ZW-for Wolff and other post-Cartesian directions, ZN-for Newton; ZM-for Musschenbroek, ZH-for Hooke, ZK-for Copernicus and Kepler, - unknown direction. Year of publication and reference codes of the items in NUK.

Undated (5)	1751 (2)	1752 (1)	1754 (18)	1755 (4)	1756 (5)	1757 (2)	1758 (5)
<i>Manfredi</i> AT-Bo-??, Wolff 1733 UM&UF- Že-ZW, Marinoni UA-Du-ZN, Hire AT- Nü(Pa)-ZK, Wiedeburg UMJ-Je-?	Nollet UP- Be (Pa)- PF, <i>Brixianus</i> UM-Br- ZN	Tertio de Lana- UP- Br&Pm- PG	Della Torre UF-Be(Ne)-??, Khell von Khellburg UF-Du- ??, Sturm&Wolff UF-Nü- ZW, Corsini UF-Be-ZN, <i>Der Königl. Akademie der Wissenschaften in Paris physische Abhandlungen</i> UP- Wr(Pa)-ZN??, Ozanam UP-Pa-ZK, <i>Genovesi</i> UF-Be(Ne)-ZG, Keri&Majláth IT-Tr-ZN, Kolhans&Schraderius OP- Le&Gö-ZH, <i>Magalotti</i> UP-Be(Fi)-ZG, Keri&Mitterpacher IT-Tr- ZN, Désaguliers UP-Pa(Lo)- ZN, Musschenbroek (4) UP- Ly/L-ZM, <i>Copernicus</i> UA- Ba-ZK, <i>Doppelmayr</i> AT-Nü- ZN	Désaguli ers UP- P(Lo)- ZN, Kraft UF-Tü (Pe)-ZM, Vater UP-Wi- ZW, Winkler EP- Le- ZN	<i>Wolff</i> (UM&) OP-Ha& Ma ZW, Regnault UF-Gr (Ri)- ZW, Varen UG-Je(Ly)- ZN, <i>Reinhold</i> UA-Tü&Wi- ZK, <i>Ritter</i> AT-Nü-??	<i>Clavius- Euclid</i> UMJ- Fr(Ri)-PG, <i>Commandin o-Euclidus & Kepler & Rheticus</i> UM,UA- Pe&Fr(Lz)	Mairan MM- Ly(Pa)-ZM, Bošković GM-Ri-ZN, Klaus UF- Du&Pr- ZN, <i>Sanvitali</i> UMJ-Br-? <i>Gooden</i> UMJ-Li-?

Table 6-29: Scientific orientation of Erberg's Jesuit book purchased in 1750s

Undecided	PG- against Galileo, Copernicus, PF- against Franklin's mainstream	ZW-for Wolff and other post- cartesian streams	ZK- for Copernicus, Kepler, ZG- for Galileo's already obsolete mainstream	ZM-for Musschenbroek, ZH- for Hooke's mainstream fans	ZN-for Newton's mainstream fans
10	4	5	5	7	10
<i>Manfredi</i> , <i>Wiedeburg</i> , Della Torre, Khell von Khellburg, <i>Ritter</i> , <i>Sanvitali</i> , <i>Gooden</i>	Nollet, Tertio de Lana, <i>Reinhold</i> , <i>Clavius</i>	Wolff , Sturm & Wolff, <i>Wolff</i> , Regnault, <i>Der Königl. Akademie</i> , Vater	Hire , Ozanam , <i>Genovesi</i> , <i>Magalotti</i> , <i>Copernicus</i> , <i>Commandino & Kepler</i>	Kolhans&Schraderius, Musschenbroek (4), Kraft, Mairan	<i>Brixianus</i> , Marinoni , Corsini, Keri&Majláth, Keri&Mitterpacher, Désaguliers (2), Winkler, Varen, Bošković , Klaus, <i>Doppelmayr</i>

Table 6-30: Sorts of books among Erberg's acquirments of Jesuit books in 1750s

Textbooks of physics and geography	Mathematical textbooks	Exam theses in physics	Experimental textbooks	Astronomical tables, atlases and textbooks	Optical, electrical, geodetic, and meteorological measurements
8	7	2	12	8	5
Della Torre, Khell, Klaus, Sturm&Wolff, Corsini, Kraft, Regnault, Varen	<i>Wolff, Wiedeburg, Brixianus, Genovesi, Clavius, Sanvitali, Gooden</i>	Keri& Majláth, Keri& Mitterpacher	Nollet. Tertio de Lana, <i>Der Königl. Akademie, Ozanam, Magalotti, Désaguliers (2), Musschenbroek (4), Vater</i>	<i>Marinoni, Manfredi, Hire, Doppelmayr, Copernicus, Reinhold, Ritter, Commandino & Kepler</i>	Kolhans&Schraderius, Winkler, <i>Wolff</i> , Mairan, Bošković

Table 6-31: The places of publications of the books which B.F. Erberg acquired for his higher Jesuit studies in 1750s (number before the placemark shows the last digit of the year of publication; in brackets are the places of residence of writers, if they differ from the places of printing of their books)

Habsburg monarchy	Netherlands with later Belgium	France and Switzerland	Venetia	Other cities in later state of Italy	Nurnberg	Other cities in later state of Germany
7 (1)	5	5 (4)	5	5.5 (3)	4	11.5
0Du, 4Du, 4Tr, 4Tr, 4L, 6Gr, (7Lz), 8Du&Pr	4*3Ly, (6Ly), 8Ly, 8Li	0Že, (0Pa), (2Pa), 4Pa, (4Pa), 4Pa, 4Ba, 5Pa, (8Pa)	1, 4, 4, 4, 4	0Bo, 1Br, 2Br&Pm, (4Ne), (6Ri), (7Ri), 7/Fr&Pe, 8Ri, 8Br	0Nü, 4Nü, 4Nü, 6Nü	0Je, 4Wr, 4Le&Gö, 5Tü, 5Wi, 5Le, 6Tü, 6Je, 6Ha&Ma, 7Fr, 7/Fr&Pe

Table 6-32: Languages of Erberg's new Jesuit books in 1750s

Latin	German	French	Italian
30	5	4	3
Khell, Sturm & Wolff, Corsini, Bošković, Tertio de Lana, Genovesi, Keri& Majláth, Keri& Mitterpacher, Kolhans (Kohlhans) & Schraderius, Regnault, Varen& Newton, Musschenbroek (3), Vater, Krafft, Klaus, <i>Clavius, Wolff, Brixianus, Sanvitali</i> , Bošković, <i>Gooden, Commandino & Kepler, Hire, Reinhold, Marinoni, Copernicus, Ritter, Doppelmayr</i>	Mairan, Wolff 1740, Winkler, <i>Wiedeburg, Der Königl. Akademie</i>	Ozanam, Musschenbroek 1739, Désaguliers (2)	Della Torre, Magalotti, Nollet

physics, and the last with natural and artificial lamps, permanent lanterns and various attractions. Especially extensive were the instructions for the preparation of luminophores, which gave young people the enthusiasm for many interesting experiments. Ozanam visited London and Oxford for several months in May 1701, so he learned all about Newton's achievements first-hand. He was not a first-class mathematician, but mostly a

popularizer, although in 1711 he became an associate member of the Parisian Academy in the class of Mechanics. Since 1678, a member of the Parisian Academy has also been Philippe de la Hire (* 1640; † 1718), whose Astronomical tables B.F. Erberg also bought for the Jesuit library. Ozanam's Mathematical Recreations have been printed in many new editions for a whole century. B.F. Erberg's collaborator Franjo Orlando bought

several Ozanam works in Trieste. Later in the 19th century Ozanam's relatives of Jewish origin joined French Catholic associations together with Cauchy in futile efforts to restore the dominance of the Jesuits in the school pedagogy.

After the Peace of Utrecht in 1713, the Habsburg monarchy occupied the areas of modern Belgium with the city of Liège included under the name of the Habsburg Netherlands. So, the Slovenes were with Brussels for some time in a common country long before EU. The Dutch Jansenists van Swieten who used to be Boerhaave and Musschenbroek's student in Leiden, was appointed as one of the leaders of the Imperial study committee in Vienna, to reform up to date mainly Jesuitical schools in 1760.¹²⁶⁵ Thus, he gladly approved the purchases of six Musschenbroek works from the years 1739-1768. In 1754, B.F. Erberg issued one and bought three Musschenbroek's books. Of course, the Jesuit B.F. Erberg could not quite follow Van Swieten's more liberal worldview. However, in his lectures, he undoubtedly defended the ideas of van Swieten's Leiden teachers' physics. We only recognize part of the books that B.F. Erberg used in physics lectures at the Jesuit college in Ljubljana since several perished in the fire of 6. 6. 1774. After Erberg's departure to Vienna (1759) in the librarians did not bookplate the years of purchase the Jesuit books anymore, but only noted the name of their library. After 1754, the head of the Jesuit library in Ljubljana was the rector, and his assistant was a lecturer of lower studies.

Procurement of the devices and books was a testimony of B.F. Erberg's interest in the research of solid matter, heat, and magnetism. He was especially close to Musschenbroek, whose measurements of water density was also quoted by Mairan.¹²⁶⁶ In his introduction to the second book, Désaguliers (1751) quoted Musschenbroek as his friend and adviser. In 1756, B.F. Erberg wrote down the proprietary bookplate of the Jesuit College of Ljubljana in the oldest known work of Newton, a 63-year-old Newtonian edition of Bernard Varen's (1622 Hitzacker, Lower Saxony-1650) General Geography to express B.F. Erberg's

later fascination with mapmaking geography.¹²⁶⁷ Ljubljana copy of Newton's adaptation of Varen was originally owned by the Styrian guy Jožef Kraus (* 11. 9. 1678 Neumarkt in Styria along the upper Mura River; SJ 6 10 1696 Judenburg; † 16. 11. 1718, Osijek) who worked as Ljubljana professor of mathematics and physics. In 1717, Kraus published a book on geography, physics and mathematics in Ljubljana, but only in the following year he wrote his bookplate on the inner cover of Newton's adaptation of Varen's book. So, he did not quote Newton in his work, certainly because of the problems he could have faced through public support for the Protestant Newton. Later, the problem was no longer acute in 1756 when B.F. Erberg officially wrote his bookplate in the Copernican books in the Ljubljana Jesuitical library. Two years later in the index of 1758 the Catholic Congregation abolished the ban on books about the real Earth's movement also advocated by Newton. The advanced educated literati of Erberg's family already belonged to best Carniolan scientists. Newton arranged Varen's book for his lectures at Cambridge to carefully replace the Cartesian description of the Earth with his own; in fact, he did not make a lot of changes since he retained all the chapters from Varen's original print (1650) in the fourth edition in Jena. Newton only slightly increased the Jena format in his edition and published 864 pages instead of the original 786; Newton added just over 10 percent of his own findings. He corrected some errors by using the new Snellius measurement of the Earth's range: he corrected Varen's distance of forty Earth's radii between the Moon and the Earth to 52. Newton improved and supplemented the values for the geographical coordinates of individual important sites, as the patient Varen did not manage to write the Longitude of thirty-one cases. Jurin added numerous quotes from English Newtonians, as well as French academics Huygens and Cassini, to the later republication of Newton's improvements to Varen's work. He retained 32 original Newton's illustrations, adding thirteen new diagrams. He also included Halley's plan of the so-called trade winds that helped the sailings of European entrepreneurs, and added geographical coordinates for 152 places; despite Cotes' ideas, this proposal did not follow

¹²⁶⁷ Varen, Bernhard. 1650. *Bernhardi Varenii med. d. Geographia generalis*. Amsterdam: Elsevier. Newton's adaptation: 1693. Jena: Croker. Russian Translation. 1718. Moscow.

¹²⁶⁵ Schmidt 1963, 141.

¹²⁶⁶ Mairan, 1752, 12.

the plan of Halley natural magnetism.¹²⁶⁸ Newton's version of Varen had mathematical and physical introduction, the chapters have been devoted to the manufacture of ships and navigation. Navigation was of great interest for Dol Erbergs and their relatives Raigersfeld, since the husband of Mary Ann Elizabeth Baroness Erberg, the Carniolan shipper Franc Henrik Raigersfeld successfully dealt with overseas trade. Raigersfeld became president of the commercial conscience and chamber councilor.¹²⁶⁹ He traded with the Portuguese as an associate of the French company d'Orlando and a member of the newly formed Oriental Society between 1721-1724. With his connections in Portugal, he also helped his wife's relative Hallerstein, when he was waiting in Lisbon for a boat for the Far East. As a member of the new Carniolan nobility, he supported Gruber's voyage and towing of ships along the Sava River, especially with Zidani most Jožef Kalasanc Erberg included F.H. Raigersfeld's legacy, family correspondence of Raigersfeld and letter of F.H. Raigersfeld's son Karel-Charles Franc Borgia Raigersfeld (* 1736; SJ; † 1800),¹²⁷⁰ who was professor of history at the Theresianum academy been between 1767-1773.

Ljubljana Jesuits' first issue of Varen's work was obtained from their confreres from Rijeka. Today, in the NUK, we even find the Russian translation of Varen, made according to the order of Peter the Great. Peter sought to improve the Russian navy and had to expand the original pocket Varen's edition to a large format. Unfortunately, the stylized initials of the original Carniolan owner of the Russian translation today do not tell us who her or she was. Erbergs also had Newton's Principles in their Dol Library in the third Latin edition, the first print outside England, published in Amsterdam in 1723; the item was estimated at 1 florin.¹²⁷¹ Even their Newton's Optics was bought in Amsterdam, but in French translation. Thus, Erbergs had the oldest examples of Newton's works on Carniolan soil and we have them rightfully for the first Newtonians in the central part of modern Slovenia. Their friend, Zois, had 'sGravesande Venetian adaptation of Newton's philosophy (1749); Erberg acquired it in the first

Leiden Latin edition of 1725. Erbergs also had Eusebio Squari's (1738) Venetian explanation of the northern light according to Newton's principles. Valvasor had indeed bought nearly all the books of Newton's role model Boyle and Newton's teacher Barrow. But he did not buy Newton's works, as it was probably too early to fully acknowledge Newton at the time of Valvasor's British journey despite of Valvasor's friendship with Newton's friend E. Halley. In 1678 in Ljubljana, the bookseller Mayr has not yet been able to sell the books of Newton, so Mayr offered Newton's opposition including the works of the English Cartesians as was Antoine Le Grand (* 1629, † 1699) with a completely new history of science experiments. Of course, Carniolan folks could have read Newton's early works published in London's Philosophical Transactions which Valvasor bought and Mayr offered in his Ljubljana store. Anyway, the Manor Dol used to be the center of Carniolan defenders Newton's doctrine for several decades before they began to take root in Bošković's ideas.

6.10.4.3 Bernardin Ferdinand Erberg's Edition of Musschenbroek's Work about Magnets

The Ljubljana Jesuits tried to follow the development of physics worldwide. An experimental manual of distinguished Dutch physicist Peter van Musschenbroek witnesses these efforts. In 1754, the Latin translation of the manual was printed at the same time in Vienna and with the professor B.F. Erberg's exam thesis in Ljubljana. Unlike the Ljubljana edition, the Viennese edition did not include any exams. The Ljubljana edition of 1754 has noted Ljubljana as the place of editing-printing. The printer was not specifically mentioned, although printers were usually referred to in examinations thesis. In the same year in 1754, B.F. Erberg purchased at least three Musschenbroek books for his College of Ljubljana. Among them was the Essay on Physics, where Musschenbroek examined the questions of vacuum in the third chapter of the first volume on pages 60-74. In contrast to the Cartesians, he claimed that there was more empty space than full spaces worldwide. He wrongly considered that water was cooling faster in an empty space than in the air, allegedly evidenced by the impossibility of the burning in an empty space.¹²⁷² He acknowledged the necessity of fresh air for divers

¹²⁶⁸ Warmtz 1989, 181, 185-186, 188.

¹²⁶⁹ Umek, 1986, 249, 250.

¹²⁷⁰ Vrhovec, 1991, 94; Kos, 2019, 10; Kidrič 1926, 164.

¹²⁷¹ SI_AS 730, GrA (Archives of Manors), I manor Dol, fasc. 71.

¹²⁷² Musschenbroek, 1754, pp. 60, 472.



Figure 6-228: Erberg's library stamp seal as coat of arms by Greek inscription in the middle of the list of his books about physics (Erberg, 1798, 100).

but still hardly guessed the role of oxygen in combustion, which was successfully investigated only later by Priestley, Scheele and, above all, by Lavoisier. In 1731, Musschenbroek devised a special device for the study of the solid-state distribution of heat called the pyrometer. During heating, the tube of the pyrometer broadened and the toothed wheel rotated on the indicator. The device could be used as a relatively unreliable thermometer that did not provide useful results.

On 11 October 1745 Kleist of Pomerania described the discovery of an electric capacitor in the newspaper. In the next issue of the same magazine, Musschenbroek immediately announced that he had already put the same device on work before Kleist. Since Musschenbroek published his popular textbooks, they called the device a Leiden jar after his birthplace where he lectured at the university. Ewald Jürgens von Kleist (1700-1748) of the highest Prussian nobility used to be Musschenbroek's eight years younger fellow Leyden student but Kleist seemingly did not fight much for his priority as he died less than three years after his discovery. He was certainly aware of its significance while today there has never been a greater need to store electricity.

The Leiden jar is certainly the most important Musschenbroek discovery, on which his reputation is based. The son of B.F. Erberg's first cousin, A. Hallerstein, tested the Leiden jar in Beijing and paved his way toward the Voltaic electrophorus and pile. Bernardin Ferdinand Erberg, as the last among his purchased devices, listed "Machina electrica" in 1755. That could be a Leiden jar or a spindle for friction electricity. Musschenbroeck published his results on 283 Latin pages with ten copper plates in many tables. Eight years after the publication of his Leiden jar Discovery, in September 1754, B.F. Erberg published a translation of Musschenbroek's magnetic research for the Society of Jesus in Ljubljana. The Ljubljana edition had two cover pages and eleven pages with sixty-five examination theses. The theses were followed by Musschenbroek's experiments with magnets, which Musschenbroek ultimately illustrated with ten full-length sketches.

6.10.4.4 Librarians Erberg

The Dol manor based Erbergs as book lovers have also proved themselves as the librarians of various



Figure 6-229 A different baron Erberg's seal with a crown was designated in Erberg's books. Here we see this seal under the experiment of the Carniolan literary history of Jožef Kalasanc written on the winter afternoons in 1825 (kept in the National Museum of Ljubljana).

Jesuit institutions. The later missionary, magister Innocent Erberg, was an assistant librarian between 1718 and 1719, while at the same time he taught grammar and syntax at the Lower School.¹²⁷³ The last Jesuitical librarian in Ljubljana was Innocent's nephew, Janez Jožef Lucius Erberg (* 11 February 1712 Ljubljana; SJ 18 October 1732 Vienna; † 29 June 1787 Dol). In 1730, he was praised for the best knowledge of Latin at Ljubljana's lower studies,¹²⁷⁴ just like his uncle Innocence before him. Eight years later, Janez Jožef Lucius taught in the lower grades of the Ljubljana grammar school. Between 1746 and 1750, he taught ethics, theology and philosophy at the college in Klagenfurt. From 1752 to 1754 he was a professor of theology and confessor in Gorizia. Between 1755-1773 he was a professor of theology, prefect, librarian and confessor in Ljubljana in collaboration with his first cousin once removed B.F. Erberg. In their reports, the Jesuits of Ljubljana continuously enrolled Janez Jožef Lucius Erberg in the second place immediately after the rector, which by itself proved his exceptional importance. In Ljubljana, he was associating with Francis Xavier Wulfen, who in 1763 taught physics according to Newton's science in Ljubljana. They often surveyed the plants of the Kamnik Alps accompanied by the count Jurij II Sigmund Hohenwart (* 1713) and his son, the Jesuits' pupil count Sigmund Hohenwart (* 7. 6. 1745 Celje; † 1825 Linz).¹²⁷⁵ During the school year they searched for the plants in vicinity of Ljubljana, and during the holidays they enjoyed longer tours to the Alps. The son of the cousin of Sigmund Hohenwart, the count Franc Jožef Hanibal Hohenwart (* 24th of May 1771 Ljubljana; 1844 Kolovec), was married to the Baroness Margareta Felicita Henrieta Erberg (* 1764 Ljubljana; † 1851 Ljubljana), the younger sister of Jožef Kalasanc Erberg. After the ban of the Jesuits, Janez Jožef Lucius Erberg officially replaced the rector Rieger, who immediately left Ljubljana after hearing the evil public reading of the letter of ban on Jesuits. Two months later, on 29 November 1773, the former Jesuit librarian Janez Jožef Lucius showed to the commission for the inventory of the property of the former Jesuits twenty-four written ternions of the library catalog that were later lost. The ternion is a section of paper for a book containing three double leaves or

twelve pages, so the catalog was by no means small. The Commission noted with surprise that the former Jesuit library was unregulated. So, they could not verify if Erberg's catalog matched the actual state of the books. The Librarian J.J.L. Erberg did not specifically explain the disorder. In any case, the Emperor Joseph II warned against the abuses if the publication of the ban on the Jesuits would delay. In fact, the disappearance of catalogue of Ljubljana Jesuits' books was one of such abuses although it is today not clear who hid the catalogue and stole the valuable books, the Jesuits or the greedy folks who administrated their former property, or both in cooperation. The unsurpassable supposed disorder of the Jesuit Library of Ljubljana is certainly very surprising and may have been the result of exceptional circumstances related to the ban of the Jesuits in Ljubljana and the fire of 1774. According to other sources, twenty-four ternions of the catalog should have been compiled by Wangg and Dolhopff. On 22 January 1774, their catalog was sent to the provincial headquarters, which sent the file to Vienna two days later. The provincial councilor baron Michael Raigersfeld, the son of baroness Marie Anne Elizabeth Erberg, mentioned in his report to the court chamber only sixteen ternions. In any case, we do not know of any of them today. On the initiative of M. Raigersfeld, the former Jesuit librarian from Steyer Wang, and Dolhopff of Vienna, immediately after the new year of 1774 began cataloging the previous Jesuitical books. On 28 June 1774, a fire broke out and damaged the books worth 12,000 florins, but mostly mathematical and philosophical works were saved.¹²⁷⁶ When the first public scientific library was founded in Ljubljana in 1774, the library of the Agricultural Society and the library treasures of the dismantled monasteries were set up in Ljubljana. The Baron Janez Jožef Lucius Erberg left the management of the new library to his former Jesuit colleague Innocent baron Taufferer (* 1. 1. 1722 Turn by Višnja Gora (Mountain) SJ 28. 10. 1738 Vienna; † 14. 1. 1794 Ljubljana). Both were Carniolan barons, so they easily agreed. The handover was facilitated by a sibling bond as they were fifth cousins once removed, since J.F.L. Erberg was an uncle of Anton Krištof Dinzl von Angerburg († 1727), married to the aunt of Innocent Taufferer. In 1760, Innocent Taufferer taught physics at the College of Ljubljana.

¹²⁷³ Diarium, 1011v; Diarium, 1045v.

¹²⁷⁴ Historia Annua, 480-481, 495.

¹²⁷⁵ Smole, 1982, 226, 345; Schiviz, 1905, 404, 409; Historia Annua, 480-481.

¹²⁷⁶ Dolar, 1974, 9-13; SI_AS 7/XI Ecclesiastica, Lit J, num. 23, vol. 1, 1774.

The librarians of baron Erberg's family have also established themselves outside Ljubljana. Erberg's younger brother Innocent (Franc Ksaver) Anton Erberg served at the College of Ljubljana until 1719, and then, during his studies in theology, for four years he was a librarian in Graz. In December 1744, he became the Rector of Ljubljana. Anton's cousin Bernardin Ferdinand Erberg was after the departure from Ljubljana between 1759 and 1763 Librarian at the elite school Theresianum for noble sons, and in 1767 the Viennese Jesuit librarian of the college. Because of their rich experience in the Jesuit libraries, the barons Erberg of course, hired librarians to regulate their private collection of books in Dol. Jožef Kalasanc Erberg collaborated with the librarian of the Theresian Academy, the priest Francesco Herbitz (Frančišek Borgia, 1752/1753 Jesenice–After 1809 Vienna). They shared common interests in plants and Carniola also because of Herbitz herbal surname. Between 1808 and 1810, somewhat thirsty Janez Anton Suppanschtsch (Zupančič, 1785 Ljubljana–1833 Koper) took care of Erberg's books until he illegally sold two valuables and Jožef Kalasanc quickly got rid of him. In December 1821, Jožef Kalasanc employed the librarian Anton Rožič. In less than two years, he dismissed him with a retribution without a certificate in June or July 1823, regardless of Rožič's book *Krain bis zum Jahre 1823*,¹²⁷⁷ which Rožič completed in the year 1824. From Trieste, Rožič sent the item to the baron J.K. Erberg, but the work was not welcomed. Rožič was from the Moravče parish above Dol, but did not finish his philosophical studies in Ljubljana despite Rožič's studies of poetry in lower school of Ljubljana in 1806.¹²⁷⁸ Since he was looking in vain for various jobs in Vienna, he was sent home in exile and in 1821 he knocked on Erberg's door¹²⁷⁹. Later, he was expelled to his home again where he died.

J.K. Erberg valued Schönleben as Valvasor's guide and Vega was noted with two sons and a daughter,¹²⁸⁰ Also, Hacquet, F. Hladnik¹²⁸¹ and Scopolí,¹²⁸² Anton Erberg's moral philosophy¹²⁸³

with dogmatic, and Šemrl were highly valued.¹²⁸⁴ J.K. Erberg did not mention Gruber, although he described the deepening of the canal between 1823-1829.¹²⁸⁵ He specifically mentioned the rebellion against Napoleon in the Duchy of Kočevje and Novo mesto¹²⁸⁶ and Nugent.¹²⁸⁷ J.K. Erberg's local history of Carniola concluded with a description of the war events in Europe by a professed enlightened thought.¹²⁸⁸ The custodians of J.K. Erberg's library were working in the southern of the two newly constructed pavilions. Erberg's led one of the first public libraries of Carniola in 1831-1880. Jožef Kalasanc liked the highly capable curator of his museum and library, Jožef Vode (Ude), to whom he left many goods in his last will. Unfortunately, there was no record of borrowed books. The Erberg library catalogue resembled the catalogue that Filip Terpin left us in the Upper Castle (Gornji Grad) Ljubljana Diocese Library where Terpin half of a century earlier borrowed the books to Schönleben and others by deleting the titles of returned books. The Erbergs knew the Upper-Castle (Gornji Grad) library well, since the uncle of Jožef Kalasanc, the Dol baron Ferdinand Benedict Gabrijel Erberg (1722-1796), was the headmaster in the Upper Castle between 1746-1751. The priest Ferdinand Benedict Gabriel then took care of his souls in Moravče parish close to his home of Dol manor until he became the dean in Ljubljana in 1760. The modern Dol library named after Jurij Vega was opened in the local school in 1854. It is the heir to one of the oldest public libraries in the Slovenian territory.

The north part of Erberg's pavilion as "art cabinet" became the first museum in the country later called Slovenia.¹²⁸⁹ Jožef Kalasanc Erberg was also interested in the history of Carniola Libraries before he opened his own library to the readers in the newly built Upper Pavilion. His own research was dedicated to the eleventh among his queries spelled as: "Where and when were gathered in Carniolan excellent libraries?" He did not just highlight his own Erberg's libraries, but also the libraries of Auersperg, Valvasor, a Jesuit library

¹²⁷⁷ Uršič, 1975, 10-11, 207; Kidrič, 1926, 163.

¹²⁷⁸ Uršič, 1965, 73; Črnivec, 1999 Ljubljanski Klasiki pp. 345, 454.

¹²⁷⁹ (Uršič, 1965, 75)

¹²⁸⁰ Uršič, 1965, 91-93, 119.

¹²⁸¹ Uršič, 1965, 112.

¹²⁸² Uršič, 1965, 81, 93.

¹²⁸³ Uršič, 1965, 120.

¹²⁸⁴ Uršič, 1965, 82.

¹²⁸⁵ Uršič, 1965, 109.

¹²⁸⁶ Uršič, 1965, 116-117.

¹²⁸⁷ Uršič, 1965, 118.

¹²⁸⁸ Uršič, 1965, 133.

¹²⁸⁹ Uršič 1975, 207; Jemec 2008, 385, 386; Kidrič 1926, 161, 165.

turned into Lyceum library, and the first public library of the Academy Operosorum.¹²⁹⁰

6.10.4.5 Theresianum Library and Prefecture

In 1728 Anton Erberg republished – patronized Karl Granelli's geographical-topographical book, mostly the part dealing with Carniola and other parts of Inner Austria. Anton paternal first cousin B.F. Erberg decided to update Anton's work, but his superiors wanted him to make the similar research on Bohemia first because B.F. Erberg had all the best opportunities as the assistant librarian of Khel in Theresianum.

As the obedient Jesuit, B.F. Erberg worked hard and produced a great book B.F. Erberg did not finish his similar work focused on Carniola which later updated his first cousin twice removed Jožef Kalasanc Erberg in literary areas. B.F. Erberg relied on Johann Christoph Müller's (1673-1721) work.¹²⁹¹ Johann Christoph Müller's elder brother married the daughter of Müller's teacher astronomer Georg Christoph Eimmart (* 1638; † 1705).¹²⁹²

After his successful mapmaking, B.F. Erberg turned to the historical studies. In 1762, he republished the work of his deceased professor of history Andrian. Erberg's collaborator Riegger the professor of German Josephine Law, Natural and International Law, in Innsbruck in 1733-1755, afterwards in Viennese University and Theresianum. He became the Ritter (knight) on 8. 1. 1762. The publication was paid by the students

¹²⁹⁰ Uršič 1975, 133-134.

¹²⁹¹ B.F. Erberg, *Notitia illustris regni Bohemiae scriptorum geographica et chorographica* Vienna: Joseph Kurtzböck, 1760, Folio, half-calf, back with ornate nerves, red slices - First illustrated edition of an engraved frontispiece flyer, 13 unfolded etch cards and a folded engraved board, out of text; Johann Christoph Müller (1673-1721). 1720. *Mappa Geographica Regni Bohemiae. in duodecim circulos divisae cum Comitatu Glacensi et Districtu Egerano adiunctis circumiacentium regionum partibus conterminis ex accurata totius Regni perlustratione et geometrica dimensione omnibus, ut par est, numeris absoluta et ad usum commodum nec non omnia singula distinctiùs cognoscenda XXV. sectionibus exhibita / à Joh. Christoph Müller, S.C.M. Capitan et Ingen.; Michael Kauffer (1673-1756) sculpsit Mappam; Wenceslaus Laurentius Reinner (Václav Vavřinec Reiner (1689-1743)) invenit et delineavit; Iohann Daniel Hertz (1693-1754) sculpsit Sectio X-XXV.*

<http://mapy.mzk.cz/mzk03/001/037/038/2619267403/>

¹²⁹² <http://gis.fns.uniba.sk/kartografickelisty/archiv/KL17/3.pdf>

of Paul Josef von Riegger. After Riegger's dedications to the empress and B.F. Erberg's introduction it had 261 pages with the addition of index.¹²⁹³

On the title of the first page of Karl Andrian's book which he promoted, B.F. Erberg stated that Andrian has been his ancient professor of history. B.F. Erberg specialized mathematic in the class of Erasmus Frölich in Graz in 1741/42 and taught grammar there in 1743/44 in the time when Andrian taught history and sacred scripture as the dean of the philosophical faculty, confessor and leader of congregations in Graz from 1727/28 to 7. February 1745. In 1761/62¹²⁹⁴ the rector of Theresianum was Henricus Kerens appointed on 16. 5. 1760. Theodor Cronstein was his minister prefect of high school and professor of experimental physics. The relative of the deceased Karl Andrian, Anton Andrian (1731 Gorizia-1761 Vienna) was prefect of law as professor of Italian Language. Karl Taupe was prefect of law (Jur.) and Franciscus Gröding taught general and more Aristotelian approach which was still called as the particularly noted part of general physics (sic!). Izzo taught descriptive (Delin.) architecture as prefect of juridical studies. Johan Schöttl taught logic and metaphysics, Johan Baptist Fischer taught mathematics, and Sigismund count Hohenwart was a prefect.

Bernardin Erberg was a socius-librarian, a kind of assistant to the father Joseph Khell von Khellburg (1713 Linz-1772 Vienna) who served as the prefect of the library of Garell (Garelli) and the first confessor. Joseph Khell was a prefect of

¹²⁹³ B. F. Erberg, entitled *Caroli Andriani, ... Epochae Habsburgo-Austriacae, Mariae Theresiae Augustae honoribus dicatae a Theodoro L.B. de Pelichy et Turksweert (1741-1811, conseiller au Conseil de Flandre à Gand, great-grandson of Amsterdam-Seville merchant Jean Pelichy who died in 1698 <http://oghb.be/recueils/la-famille-de-pelichy>), dum idem sub augustissimis auspiciis in regio Theresiana nobilium collegio-tentamen publicum ex jurisprudentia publica universali, gentium er particulari sacri imperii Romano-Germanica subibat Praeside perillustri, ac juris contultissimo viro domino Paulo Josepho Riegger (1705 Freiburg im Breisgau-1775 Vienna) Sac. Caes. Reg. Majest. A Consiliis Aulicis & Canonum Professore P. & O. Societatis Liter. Roboretauae (Rovereto in Tyrol=Trentino) Socio (Lectori Bernardinus Erber S.J. Autoris olim in historicis discipulus = Edidit R.P. Bernardinus Erber.). Viennae Austriae: Typis J. Kurtzböck, 1762 http://reader.digitale-sammlungen.de/de/fs1/object/display/bsb11026318_00295.html.*

¹²⁹⁴ Catalogus, 1762: 37-38.

library, but also a professor of history and numismatics, teacher of the Greek Language, confessor in the Jesuit house and the second confessor. Khell studied philosophy with Anton Kappler who studied philosophy-physics in Graz with Franc Dannhauser and mathematics with Jakob Urient who was a student of Ernst Vols. Khell was promoted by Erasmus Frölich and criticized Zanchi. In 1751, Khell published his widely used physics textbook entitled *Physica ex recentioris observationis accomodata usibus academicis* in Vienna which B.F. Erberg acquired for his lab in Ljubljana. Khell's textbook was praised even in *Nova Acta Eruditorum* in Leipzig in 1753 on pp. 360-362. It was reprinted in Vienna in 1754 and 1755.

By using the great Garelli's library and with the help of the Jesuit Joseph Hilarius von Eckhel (13. January 1737 Enzesfeld bei Baden in Austria under der Enns-16. May 1798), Khell von Khellburg and his student Frölich advanced the numismatic into an academic discipline and published *Numismatica* in 1755; *Erasmi Frölichi ... numismata* 1751; *Epicrisis observationum Cl. Belley Academici Parisini in nummum Magniae Urbicae* also on numismatic in Vienna in 1767 with designs of the Abbé Augustin Belley's (1697-1771 Paris) Parisian book *Differentes pensées d'ornements arabesques*. Khell was a member of Academy Corton in Vienna.

Pius Nikolaus von Garelli (* 10th September 1675 Bologna; † 21st July 1739 Vienna) was the Viennese imperial physician and the husband of Maria Barbara Cäcilia von Schickh, the daughter of Georg Friedrich Ritter von Schickh who took care of Pragmatic Sanction. Garelli studied in Bologna and got his Ph.D. in medicine on 26. March 1695. Next year he came to Vienna. In 1703, he became one of the personal physicians of the future emperor Karl VI. Garelli became dean of Faculty of Medicine in 1703, and prefect of court library in 1723. In 1728 Garelli accompanied Karl VI to Trieste and examined newly exhibited Roman tombstones in Styria and Carinthia to bring them to the Viennese court library. In 1732, Garelli became the first imperial physician of the emperor Karl VI, but he was not so innovative as his descendant Gerhard van Swieten. Garelli collected valuable and expensive books and gave them with his testament to the court library, altogether 1932 works. B.F. Erberg certainly loved them all.

As the assistant librarian of Khell, B.F. Erberg had every reason to republish Andrian's work, especially as the glorification of the heritage of the empress Maria Therese. In his preface to the reprint of Andrian's masterpiece on pages I-X, B.F. Erberg described the merits of Karl Andrian and his published works (VII-XIII) including *Corollaria Curiosa ex Catoptrico-Dioptriciis Principiis collecta & pro Academico Mathematico exercitio proposita*. Klagenfurt: Matthia Klerinmayr 1714 reprinted by Josef Kössler in Vienna by Kaliwoda in 1750, and by Maximilian Götzen (* 1723 Prague; SJ 1739 Vienna; † 1798), and Franz Xavier Staininger in Linz in 1759. Andrian's optics resembled Sebastian Stainer's exams in Ljubljana in 1714. Andrian also published *Novissijma Carinthia Tabula Chorographica, Epocha Habsburgi-Austriaca...* with his student Ignaz count Atthemis (Ignaz Maria Maximilian Dismas Joseph Leander Attems (26. 2. 1714 Graz-17. 6. 1762 Vienna) who married Maria Josepha countess Khuen von Belasi zu Auer und Lichtenberg (* 4. 8. 1721 Hall by Innsbruck-1. 4. 1784 Vienna) in Vienna on 29. 10. 1739. Their book was published in Graz by Widmansatet in 1730 and reprinted in Vienna by Trattner in 1750.

In his 1762 reprint on pages XIV-XVIII B.F. Erberg added Index and a separate double page of the Habsburg Genealogy with additions of Maria Theresia offspring born or died after Andrian passed away in February 1762 including the daughter of Josef II Theresia Elisabeth (* 20 March 1762–23 January 1770) which indicated that B.F. Erberg prepared the work late in 1762. After that, Andrian's own historical work was printed up to page 281. Index of persons on the end provided just Habsburgs, and not for example, the emperor Sigmund of Luxemburg or his wife Barbara.

6.10.4.6 Trnava Ministry and Prefecture

In between his two terms in Theresianum, B.F. Erberg left for the Hungarian part of Habsburg monarchy to serve as minister, prefect of temple and confessor in Slovakian Trnava in 1765-1766. The clouds already gathered over the Iberian and French Jesuits of those times when even the Roman Jesuits were far from popular. Despite of those failures, the positions of Jesuits in Habsburg

areas still looked like fine and nobody really expected the final Viennese blow.

B.F. Erberg's rector in Trnava was Nicolaus Schmitth appointed on 15. 10. 1764. In 1763-1765 in Trnava, the professor of mathematics was the Hungarian catechist Anton Jarányi (Jaránui, 1725 Pécs -1797 Pécs), and Johannes Baptist Schwelmer (1728 Banska Bystrica-1775) replaced him in 1766-1767. In 1765 the Slovakian Anton Muszka (1719-1790) headed the local library after he published his *Heroes Daciae* in 1744 and taught some physics in Košice. Johannes Gottgeisl taught physics while Johannes Mólnar taught logic and metaphysics and Josef Führer headed the specialization in applied mathematics. Michael Horváth was an adjunct to the prefect of astronomical observatory Franz Weiss.¹²⁹⁵ In 1765/66 Janos de Tordas Kaloz Sajnovics (Sainiovics, 1733 Tordas-1784 Pest) became new Weiss' assistant and accompanied their friend Maximilian Hell to Laplandic Venus's transit journey. Under prevailing Venus' influences which are always dangerous for the priests Sajnovics suddenly turned into a kind of compared linguist in the Jesuit traditional manner of a polyglot.

Weiss' astronomical measurements and his assistants were among the best worldwide, but B.F. Erberg was never very impressed with astronomy like his first cousin once removed Augustin Hallerstein in Beijing.

6.10.4.7 Ljubljana Returns

In 1771/72, B.F. Erberg returned to Ljubljana college for his very last time. His family was glad to offer to him a devoted book of Liborio Siniscalchi (1674-1743) *La scienza della salute eterna: ovvero Esercizi spirituali di S. Ignazio* printed in Venezia by Tommaso Bettinelli in 1755. The book was leather-bound with red stained edges and gilded front and back covers and spine. There was the coat of arms of the barons Erberg on the front and back covers with the motto "Non est mortale quod opto", and black propriety entry of the Barons of Erberg on title page.

In Ljubljana, B.F. Erberg was minister of his old friend the rector physicist Karl Dillherr (1710 Vienna-1778 Stein by Krems) appointed on 26. 4.

1768, prefect of church and temple, as well as the confessor. Liker B.F. Erberg, Dillherr promoted many books but more vehemently concentrated on somewhat obsolete Kircher-Linus filled vacuum and Tycho's astronomy. On confessions, B.F. Erberg discovered the great talents of otherwise poor farmer's son Jurij Vega and told his professors Bernardin count Hohenwart on the chair of logic-metaphysic, head of seminary Moraučer, G. Gruber, Michael Schmid and after him Maffei on the chair of mathematics, prefects of lower and higher schools Innocent baron Taufferer and Ignaz Rasp, professor of moral theology former mathematician Ignaz Rosenbeger, G. Schöttl, and his own first cousin once removed the librarian Joseph Erberg (Catalogus 1772: 16): "We have an extraordinary guy here! His mathematics is more than excellent. Please, take care for him, not just because he was born near our castle of Dol, but also because he is a real genius!"

6.10.4.8 Last Stops in Krems by Danube: Erberg's Great Influence on Jurij Vega and their Other Talented Neighbors Born Near Dol Manor

B.F. Erberg headed the seminary as the prefect of musical college chorus in Krems in 1768-1771. He liked the nice small peaceful city and returned there in 1773 to pass his last days just like his friend Dillherr did few years later in somewhat strengthened circumstances with their Jesuit order no longer in power. In 1768 in Krems, B.F. Erberg's rector was Johan Nepomuk Bottoni (1707-1790 Krems) appointed on 23. 2. 1766¹²⁹⁶ Bottoni used to teach physics in Ljubljana in 1744/46, therefore he and B.F. Erberg shared many friends and memories. There were no mathematical and physics lectures in Krems, but the folks had fun anyway. The lyrical Jesuit poet Lorenz Leopold Haschka (Haska, 1749 Vienna-1827 Vienna) studied in Krems with B.F. Erberg and became a Jesuit in 1764. Haschka specialized languages and applied mathematics in Graz and returned to Krems as the lecturer of grammar to help his teacher B.F. Erberg in his last days.

Four months B.F. Erberg's younger acquaintance Martin Johann Schmidt (Kremser Schmidt, 25 September 1718 Grafenwörth of Lower Austria east of Krems on the way to Vienna-1801 Stein-

¹²⁹⁵ Catalogus, 1765: 29-30.

¹²⁹⁶ Catalogus 1768: 8.

sur-Danube) became the very leading Habsburg painter draughtsman, etcher and engraver of late Baroque and late Rococo. Kremser Schmidt worked in Ljubljana for G. Gruber. In 1756, Kremser Schmidt settled in the centre of the local white wine production called Krems joined by Stein east of Vienna and worked there sometimes in B.F. Erberg's company in the Jesuit college established in 1616 until his very end. The Capuchins established their monastery nicknamed Und between Stein and Krems six years before the Jesuits in 1612.

The barons Erberg were closely associated with the Jesuit College of Ljubljana. Everybody studied there and many used to teach. At the time of the Vega study, first cousin once removed of B.F. Erberg. Volbenk Daniel Erberg (* 1713; † 1783), was the owner of Dol manor and the library, which was in his Ljubljana Baroque palace on Mestni trg no. 17 (then Ljubljana No. 237) until 1810. The building was renovated in 1748 and 1758.¹²⁹⁷ With the recommendation of his school confessor B.F. Erberg Jurij Vega could use the local library of his lord Volbenk Daniel Erberg, where he examined primarily Schooten's table of angular functions and Wolff's logarithms. Bernardin Ferdinand Erberg had a strong influence on the young Vega. He certainly also gave him a kind of support suitable for the poor people.

The 17-year-old student baron Jožef Kalasanc Erberg (1784-1793) met the captain and professor Vega in high circles when Vega returned for a short time to his teaching of mathematics in Vienna in 1793. Of course, this was no longer a meeting of a superior landowner baron Erberg with his subject, as Vega soon climbed up to baron's title too. In his Experiment of Carniolan Literary History, Jožef Kalasanc Erberg mentioned four times Jurij Vega and classified his mathematical works as a classic. Twice he emphasized that Vega was born in Zagorica above the Sava river. In the Vega age, before the independence of the Dol parish at the end of the 18th century, the Zagorica was not part of the parish Dol but of Moravče parish.¹²⁹⁸

Vega was not the only successful Erberg's student from the immediate vicinity of their Dol manor. In 1749, Franc Anton Završnik (Saverschnigg) from

Moravče bound Johann Baptist Klauber's (1712 Augsburg-1787) engraving of St. Norbert (Gennep, c. 1075 Xanten-Magdeburg-1134) and dedicated it to the count Kajetan Wildenstein (Josef August, 1703 Styria-January 6, 1764 Ljubljana) of the German Knight Order in Ljubljana in 1738-1761. Six years after France in 1755? his neighbor Martin Dettela (Detela) from a well-known Moravče family completed his studies in Ljubljana. He had bind to his exam questions Salomon's anointing etched by Philip Andreas Killian (* 1714 Augsburg; † 1759 Augsburg) by the painting of Gerard de Lairese (1641 Liège-1711 Amsterdam) of 1668. Martin dedicated the etching and examination thesis to the uncle of Jožef Kalasanc, then local Moravče parish priest Ferdinand Benedict Gabrijel Erberg,¹²⁹⁹ who quickly found the necessary coins for printing. Martin became priest after his first tonsure on April 10, 1751. Jožef Kalasanc obtained a collection of the examinations of the two Moravče natives from his uncle's legacy, as they were usually shared with the audience at the public examinations in Ljubljana. Jožef Kalasanc Erberg kept copies of both examination theses of his Moravče neighbors in his Dol library. Jožef Kalasanc Erberg specifically mentioned them in his experiment in Carniolan literary history.

6.10.4.9 Erberg's Manuscript of Physics (Physiology)

In Archive of Republic Slovenia under the reference code AS 1073 (manuscript 242 r), 129 leaves with bound book of half A4 format are stored as a continuation of the first 15 leaves with notes of the manuscript 178r. Every other page of the text is paginated. Therefore, we will mark the left side with "a", and the right with "b". The title page is "Erberg: Physics". The text is German in Gothic script. Therefore, it is assumed that manuscript was not produced at the college in Ljubljana, where the German language dislodged Latin language barely in the mid-eighties. In Vienna and Graz, the German language has already become established in science. The manuscript has a seal of Erberg's library. In the index and on the cover, Erberg is listed as the author. Manuscript is not dated. The next manuscript in the Archives of the Republic of Slovenia AS 1073 (143 r = 243r) has a year of 1744. Around this year, the author of

¹²⁹⁷ Kidrič, 1926, 163; Prelovšek, 1984, 184-185.

¹²⁹⁸ Uršič, 1975, 80, 96, 121, 252; Jemec, 2008, 383.

¹²⁹⁹ Uršič, 1975, 148; Kidrič, 1926, 161.

the manuscript could have been Bernardin Ferdinand Erberg, who could write it during his studies in Vienna from 1739/40 until 1740/41 and later took the item with him to the college in Ljubljana. The author can also be his older first cousin Anton, or Jožef Kalasanc Erberg much later.

In his student manuscript of physics, Erberg described the physiology of man. He discussed in parallel the physics issues of heat in the body and the light in the eye. Therefore, the later title "Physics" is incorrect from the modern point of view, the more appropriate would be: "Physiology". He added a lot of physics and chemistry to the treatment of air pressure (1, 48), vacuum (2a), vacuum pumps (15a), phlogiston theory (8b-11b) with Adair Crawford (1748 - July 29, 1795) noted as Craford (44b), a camera obscura (58), an eye (60a), a short-sightedness (63b), an acoustics (13b, 17b, 19a), planets (21b), arteries and veins (27a) and concave lens optics (64). According to the notes about Crawford, probably focusing on German translation of Crawford's works of 1785 or 1789, the item may have been used for the student notes of Jožef Kalasanc Erberg (* 1771) from 1789 or 1790. J.K. Erberg completed his third year of gymnasium in Vienna in 1784 and finished his studies in logic in 1788. In 1789, he attended the lectures of mathematics of the professor Metzburg. A year later, J.K. Erberg studied philosophy, perhaps with Ambschell. In 1791, J.K. Erberg studied the National law, and in 1792 the Civil and German State Law. Such notes may have been illustrated by Ambschell's lectures.

The text was subsequently numbered on every second page. The first fourteen sections of the manuscript were not preserved. Thus, the manuscript is now starting with the fifteenth paragraph on air and air pressure. He then considered the vacuum and the problem of fear of vacuum nicknamed horror vacui. These questions were extremely popular one hundred years ago when Torricelli discovered the barometer and explained its operation with air pressure. In Erberg's time, the air pressure already completely displaced older Aristotle's ideas.

The text continued with the description of arteries, lungs, and the circulation of air in the blood. The oxidation which behaved like burning air in veins,

blood and lungs¹³⁰⁰ was described by the theory of phlogiston and its elimination from the air.¹³⁰¹

The phlogiston theory was developed at the beginning of the century by the German chemist and physician George Ernst Stahl. It was used up to Lavoisier's burning experiments and calorie theory in the 1770s. The Zagreb professor Josip Franjo Domin argued for the phlogiston theory in 1784,¹³⁰² Kant in 1787,¹³⁰³ J. Priestley and others even later.

In the following, Erberg wrote about sounds, musical instruments and tone modulation. He switched from acoustics to physiology and discussed emotions, odor, hearing, and elasticity of the air and other bodies.¹³⁰⁴ He dealt with light and vision in detail. He illustrated his eye with the camera obscura, which B.F. Erberg acquired in 1755 for the new cabinet of the Ljubljana College. In a modern way the author of the manuscript described short-sightedness, other eye defects and types of lenses. He wrote some interesting physics, especially concerning the theory of phlogiston.

¹³⁰⁰ Erberg, 1740, 9.

¹³⁰¹ Deflogistonische Luft (Erberg, 1740, 8-11).

¹³⁰² Dadić, 1982, 1: 356.

¹³⁰³ Rousseau, 1955, 337.

¹³⁰⁴ Schmidt, 1963, 148.

7 First Major Industrial Uses of Vacuum and Overpressure Technologies: Steam Engines

7.1 Steam Engines - Introduction

Erberg family promoted the new knowledge and technologies including steam engines in Carniola and nearby. In the 18th century, the designers of steam engines used vacuum technology for the first time in industry. The development of steam engines therefore moved from the scientific laboratories of educators to workshops of gifted self-taught inventors. The development of technology has been a forerunner of science for decades. Thus, the first serious theory of the steam engine's operation was only published by Carnot at a time when steam engines were already widely used in developed parts of Europe. In many other examples the scientific theoretical explanation might figure as the forerunner of industrial technological (mis)use like in the cases of lasers or atomic bombs, but in the development of steam engines the relation between both parties were clearly turned in opposite directions.

7.2 Vacuum Technology in a Steam Engine

The peg-top propelled by steam jets nicknamed aeolipile was among the best Heron's designs around 50 AC in Alexandria in today's Egypt. Heron's more practical approach relied on earlier designs of Ctesibius (Ktesibios, Tesibius, 285–222 BC) and Vitruvius (c. 80 BC – c. 15 AD). Heron's appealing idea was improved by Blasco de Garay in 1543, Solomon de Caus in 1615, the Italian Giovanni Branca in 1629, the Marquis de Worcester in 1663 and by the Sir Samuel Moreland in 1682. Huygens's research of those overpressures in newly created AR program was presented to the almighty minister Colbert in 1666. Huygens intertwined by almost the same breath the pioneering research on the vacuum pump and the driving force of the water vapor. He therefore combined overpressures and lowered pressured with nearly the same technique. His assistants Leibnitz and Papin endorsed the same approach to become the most famous among men who

developed both vacuum pumps and steam engines. The invention of cooking under high pressure enabled Papin's election to the RS in 1680. Papin's may well have been obtained that excellent idea during his service to Boyle, who in the 1660s had boiled water at the lower temperatures under pressure below 1/30 bar. Between 1690 and 1695 in Marburg Papin compiled the first usable steam engine with a piston, which have lifted even 27 kg. In 1698, he improved his steam engines in Germany and Italy, but neither RS nor other wealthy patrons supported his plans. Today, it is surprising that Papin did not use a special boiler in his device, but instead contributed to the role of the boiler as a cylinder, from which he had to pull in or out of the piston at every engine cycle. Such design was relatively unusual in Papin's time also because Papin did not have the necessary craftsman's experience.¹³⁰⁵ In correspondence with Leibniz he made a well-known steamboat, but the authorities in Fulda destroyed it because he did not pay the required fees. The politicians have always worked hard against great scientists and have taken care of today's and not for future glory. According to other sources, Papin made a normal ship without a steam drive which angered the local fisherman. In any case, the gullible Papin invested all his possessions in the ship, so he was devastated after confiscation because he planned to sail to England to impress the queen Anne in September 1707.

The Englishman Savery from Devonshire used Papin's idea and the results of Boyle and Guericke's vacuum research. Savery's Friends of Miners with 500 horsepower were mainly used to pump water from the mines. In 1698, Savery obtained a patent for his device and accepted his neighbor a blacksmith Newcomen from Devonshire as a partner. The following year Savery presented his working model to the RS fellows, where it was certainly rated by Hooke. The sketch was published in Phil. Trans. with Savery's notes, and Savery was elected as a new fellow of the RS. Savery was certainly wealthy enough to pay the RS fees. Unlike his predecessors, he did not hide anything mysterious as he published a detailed description of his device to get the RS monopoly on fire powered engines while Papin and Leibniz criticized his claims as a part of Newtonian propaganda against Leibniz' networks.

¹³⁰⁵ Sittauer, 1989, 7, 9; Bogoljubov, 1984, 209; Frankfurt, 1976, 155; Asimov, 144–145; Dickinson, Vowles, 1945, 21.

Newcomen had already corresponded with Hooke about the atmospheric engine and Papin's device in the 1680s. As the old fan of the voids, Hooke advised the use of a vacuum under a piston, which would allow the atmospheric pump to function successfully.¹³⁰⁶ In 1712, Newcomen assembled a device that did not use steam at high pressure, but the work was carried out at the normal air pressure. The pistons and cylinders must therefore be very well sealed, which was later the basic idea of Vega's improved mortars. Newcomen's steam engine remained in general advanced use from 1725 to Watt's improvements, although Newcomen's designs were far too heavy for anything portable. In 1711 and 1712 the similar devices were built by Newcomen's partner the Englishman John Cawley (Calley, 1663 – May 1725 The Hague), followed by Swedish inventor Christopher von Polhem. However, the craftsmen of their time were not yet able to put together vessels that would work safely under vigorous vapor. John Kay in 1733, John Wayatt, Lewis Paul, James Hargreaves in 1764, and Arkwright with a spinning machine in 1769 enabled the use of steam engines in the textile industry.

The Scotsman Watt first used the second container as a condenser in Newcomen's machine in 1769. This avoided the losses of older models where at each cycle steam had to heat up again the water, which already participated in the previous cycle. This increased the speed of the piston movement, which did not exceed 20 liftings per minute before Watt.¹³⁰⁷ After Watt's improvement, it was no longer necessary to wait for the heating of the container. Watt's steam was pushed by a piston alternatively from both sides, which was not possible with Newcomen's design. Watt's products were much lighter and able to transform the linear motion into the rotations needed for steamers.

In 1756, Black was named Professor of Chemistry at the University of Glasgow when Watt was set up there as a "maker of mechanical devices".¹³⁰⁸ After the initial Black's support, which was not black at all, Watt joined the English businessmen and began to produce steam engines for the market in 1774. In 1781, he composed leverage with which the movement in one direction could rotate the wheel. The invention has opened new areas for the

use of the steam engine, first in the iron industry. Until 1790, Watt's products completely replaced Newcomen's engines and started to be used in France. In 1800, the English used already 500 Watt's steam engines. Carnot published the theory of steam engine operation in 1824. Carnot's book was too technical for physics and too mathematical for technologists; so, it was correctly assessed only by the next generation. He used the wrong measurement of Delaroche and Bérard's dependence of the specific heat of the air on the pressure issued in 1812. He expanded his results to the pressure range between 1/1024 and 1024 bar and tabulated the results. In the following, he assumed that air at a pressure of 1000 bar reached the density of water and was liquefied, with the last claim being incorrect.¹³⁰⁹ The highest pressures from Carnot's table were achieved only by the physician Johann August Natterer in Vienna in 1844, and the lowest pressures from Carnot's table were achieved only by Töpler at the University of Jena eighteen years later.

7.3 Steam Engines in Carniola

In 1596, the first notes about the power of steam appeared in Ljubljana notes of Gregor Corissa on the fireball of Joachim Turekh. A century later soon after the establishment of Ljubljana Higher studies on October 4, 1705, Zaharias Greyl (Greil), a citizen and a copper dealer from Augsburg, described his research of the fire of steam engine in Ljubljana. It was made of copper and worked circularly according to the unnamed English model, probably designed by Papin's modification of Savery's engine to lift water onto a water wheel for rotary power. Greyl stated that his device could be used for rarefaction (of air) and for the propelling of ships. A similar device has been used in Upper Carniola (Gorenjska) already for three years. On July 27, 1717, Greyl asked the Carniolan provincial States general and emperor for financial support amounting 1000 ducats. The illustration scheme was attached to his file.¹³¹⁰ Greyl's Ljubljana projects were parts of his broader efforts in Holy Roman Empire. In 1716 in Augsburg Zaharias Greil made successful attempts with a barrel filled with water which was scattered to all sides like the finest dust or a vapor blown up by powder. In 1718 the same silver engraver from

¹³⁰⁶ Bogoljubov, 1984, 180–181; Nichols, 1999, 110–111.

¹³⁰⁷ Sittauer, 1989, 11, 13.

¹³⁰⁸ Dickinson, Vowles, 1945, 29.

¹³⁰⁹ Carnot, 1953, 61–62.

¹³¹⁰ ARS, SI-AS 1 Vicedom's archive, box 181, fasc. I/102.

Augsburg Zacharias Greyl (Greyl) invented and designed his fire extinguisher for cooking. He promoted his novelty in Augsburg, Vienna, Regensburg, Dresden and Paris. The so-called Greylsche extinguisher, which Zacharias Greyl invented in Augsburg; through them a fire can swiftly evaporate smaller quantities of water with a help of several men. The machine has the wooden vessel of the dimension 10 x 20 inches. The openings were sealed with wooden screws. The cylindric rifle made of lead (bleicherne cylindrisch Büchse) with diameter of 3 inches and height of 9 inches was used as the heater with powder. The third part of design was the machine of small vehicle with long shaft. The city of Augsburg granted the official patent (Copia Attestati) to Greyl for his newly invented swift fire extinguishing machine for cooking with extinguishing bomb (Löschbombe) on 16. 4. 1720 and 30. 10. 1720. On 5. 8. 1721, aspirations of the widow of Greyl named Elisabeth were altogether successful, because of the previous demonstration of the extinguishing bomb as the attestation of the advice of the city of Augsburg.¹³¹¹

A century after Greyl's proposals, the first steamer on the Slovene ethnic territory was tested in Trieste in 1818, where the Bohemian German Ressel performed his experiments with a screw in 1829. In 1835 they set up the first steam engine in Carniola in the Ljubljana house named Cukrarna (Sugar-Factory). Five years later, the first steamer was rounded up along the Ljubljanica River by a power of 14 hp.

Due to the good administration and efforts of the Auersperg princes, the grandchildren of the first Carniolan vacuum researcher, Janez Vajkard Auersperg, their Kočevje manor was one of the most advanced industrial centers in Carniola in

¹³¹¹ *Copia Attestati, Welches von Einer Wohl - Löblichen Reichs - Stadt Augsburg, Zachariä Greyl, Bürgern allda, einer neuinventirten geschwinden Feuer - löschenden Maschine halber, ertheilet worden.* 1720; Johann Heinrich Moritz von Poppe. 1804. *Encyclopädie des gesammten Maschinenwesens, oder vollständiger Unterricht in der praktischen Mechanik und Maschinenlehre: mit Erklärungen der dazu gehörigen Kunstwörter in alphabetischer Ordnung: ein Handbuch für Kameralisten, Baumeister, Mechaniker, Fabrikanten und Jeden, dem Kenntnisse der Maschinen nöthig und nützlich sind.* Volume 2. Leipzig: Georg Voß, 202-203; Alexander Jürgen Flechsig, 2013, *Frühneuzeitlicher Erfindungsschutz: eine Untersuchung unter besonderer Berücksichtigung der Reichsstadt Augsburg*, Münster: LIT, 129-131.

19th century. In 1840, Pugster set up a steam engine in the Gottscheer Glassworks (Kočevska Glažuta), where the Auersperg family was running a glassware factory from 1837 to 1852. In 1870/71 a steam powered saw was placed there. In 1844, the first steam sawmill in Carniola and the other Slovenian territory was placed on the premises of today's bus station in Kočevje. Its power was 20 hp. Just before the March Revolution, Auerspergs began to place steam engines in their Ironworks in Dvor. Thus, they took advantage of the vacuum technique that the first prince of their genus helped to establish two centuries earlier. Janez Vajkard Auersperg's pioneering spirit helped his heiress to develop the domestic vacuum of steam engines. Later, their Ironworks in Dvor were closed because their Slovenian political antagonists put the tracks of the railway as far from Dvor as possible.

7.4 The First Steam Engines Discussed in Print among Slovenes

Steam engines were the first serious testing of the usefulness of the new vacuum technology, although the essential area of the steam engine is naturally overpressure. De Maillard's steam engines attracted among the first the attention of the people of Ljubljana. In 1783, De Maillard received the Petersburg Academy Award for his description of steam engines in the French language. In 1784, his book was reprinted. In the year 1800 de Maillard was a correspondent member of the Petersburg Academy, and in 1817 he published a book on navigable canals. In 1783 as a lieutenant colonel he was the director of hydraulic works in the monarchy, where he replaced the professor of Ljubljana Gabriel Gruber, who until then had been the director of all hydraulic works on the Habsburg rivers, except the Danube. Thus, Gruber acquired De Maillard's books for the Ljubljana Higher Education Library.

De Maillard (* 1746; † 1822) of French origin served in the Habsburg army. In 1784, he was the Habsburg Captainlieutenant; together with artilleryman Jurij Vega in 1789 he participated in battles for Belgrade and then in battles against the French. So, in 1800 De Maillard became a colonel of imperial units. He began the introduction of his book with a description of the history of steam engines of Savery and Papin. He believed that the

Englishmen were the first to build steam engines, but only a few were designed in other parts of Europe. He did not even mention the Habsburg monarchy, which apparently lagged somewhat behind. Certainly, De Maillard did not know much about the eastern origins of his steam engine like Badī' az-Zaman Abū l-'Izz ibn Ismā'īl ibn ar-Razāz al-Jazarī's (بديع الزمان أبو العز بن إسماعيل بن الرزاز الجزري, Jazari, 1136 Mesopotamia–1206 Mosul) double-action suction pump with valves and reciprocating piston motion of 1206, rotating spit steam engine of the Istanbul inventor Taqī al-Dīn Muhammad ibn Ma'ruf ash-Shamī al-Asadī (تقي الدين محمد بن معروف الشامي, Takiyüddin, Taki, 1526 Damascus–1585 Istanbul) designed in 1551 or Tiangong Kaiwu's (1587-1666 AD) Exploitation of the Works of Nature as a Chinese encyclopedia of Song Yingxing (宋應星, 宋应星, Sung Ying-Hsing) with various gunpowder weapons and tools published in May 1637 as the technological extension of Song Yingxing's dichotomies between the solid *xing* (形) and living energy *qi* with fire intermediary between those two forms.

In the first part of the book De Maillard described a steam engine. In the second part De Maillard discussed the theory of the steam engine, the piston and the pump. He calculated the efficiency of the devices and described the performance of the machine in Bois-bossu near S. Guislain in Habsburgian Haynault (Hainaut) as one of two areas that form the eastern area of département du Nord while the western part is today in Belgium). It has a diameter 30.5 "pouces" (75 cm) with a 6-foot piston (2 m) and 32 cubic feet of emptied workspace. The first French steam engine designed by T. Newcomen's inventions in the city of Fresnes now in southern-southwestern suburbs of Paris was capable of 15 revolutions per minute in 1735; for that times, it was an enviable speed.

In the third part of the book, De Maillard offered his theory of modern devices propelled by the fire. Savery and Newcomen's machines have already undergone many changes. One of the basic problems was to prevent the cooling of cylinder. De Maillard did not mention the improvements of the Scotsman James Watt. As early as 1769, Watt's invention surpassed the efficiency of Newcomen's machines and completely replaced them by 1790. Of course, in the Habsburg monarchy the local experts had somewhat delayed the news of Watt's

success.

De Maillard calculated the maximum efficiency and increased the pressure of twice greater amount of steam at the same volume. Of course, he did not know the later Carnot's ideal steam engine, and he published numerous copper plates for steam engines used as weightlifting machines mostly in mines. According to Maillard, Friderich Franz Edler von Entressfeld (Entersfeld) from Vienna designed the steamer with the working title *Maschinenschiffes*, which was tested by the professor Gabriel Gruber in at least two versions in nature in Mura river by Graz. The Styrian agricultural society supported the plan as Entressfeld was its member. From the reports of Graz Gubernia, we can see that Gruber first put in place a wooden bearing model reported to Emperor Joseph II on 7. 12. 1779;¹³¹² his mother Maria Theresa died shortly afterwards and did not trouble herself with such headaches. On Mura by Graz Gruber tested a new type of vessel named the machine ship and it was probably equipped with a steam engine; of course, not a heavy Newcomen's machine, but rather with Watt's design. The prevalence of sailboats was already damaged, even though "the opponents" with their noisy steam did not go smoothly towards their inevitable success, especially when Karolina steamer sunk in the Drava river in 1821.¹³¹³

It cannot be proved that Gabriel (Gabrijel) Gruber used any steam engines during the construction of the Gruber's Ljubljana river canal, although he had to draw water during his workers' excavation and digging. Gabrijel Gruber used new vacuum technologies among the first in continental Europe, and with Gabriel Gruber younger brother Tobias rejected Darwin's assumption about the mechanical expansion of gas from a steam-powered miners' pump, which supposedly took heat away from the body of a valve in the Slovakian Banská Štiavnica. T. Gruber ensured his readers that the dilution of liquid caloric only affects the bodies nearby, as denser air does not emit heat to the surrounding area. Three years earlier he used his own measurements of the dependence of the boiling point of water on external pressure,¹³¹⁴ his own

¹³¹² StLA, R+K, K 83, Wasser Sachen, fasc. 34, Dec 38 (26. 11. 1779), 1^r-3^r

¹³¹³ Sokolić, 1979, 99–100.

¹³¹⁴ Gruber, 1791, Bemerkungen über H. Erasmus Darwins, 190.

research of the charged clouds as thermal insulators was published in 1790.¹³¹⁵ With the assumption of cold high parts of the atmosphere, T. Gruber explained the formation of a hail in an allegedly similar tides of the atmosphere, as seen in the oceans. Certainly, the global-scale periodic oscillations of atmosphere analogous to the seas were studied only after Torricellian experiments as the peculiar feature of these atmospheric surface pressure tides makes them primarily solar semidiurnal. Laplace concluded that the solar dominance implied their thermal origin.

¹³¹⁵ Gruber, 1791, *Bemerkungen über H. Erasmus Darwins*, 192; Gruber, 1791 *Betrachtungen über die Bestandtheile*, 195–196, 203.

8 Pioneering Vacuum Electronics: Low-Pressure Glow Discharge Tube

8.1 The Rapid Progress of Vacuum Technology in the Second Half of the 19th Century

8.1.1 *Stagnation in the Development of Vacuum Technology by the Middle of the 19th Century*

The steam engines used vacuum technology and provided new hints. Because of the long delay in the efforts to achieve the best possible vacuum, after the invention Hauksbee's pump was on sale for a half a century without major changes. In 1850, at the Great Exhibition in London, the first prize was given to Jeremiah's son Francis Watkins (1800-1847) and William Hill's (before 1780-1847) pumps with a double tube, an oiled silk valve and conical pistons. It reached a pressure of 1.3 mbar, which was only six times better than two centuries earlier Boyle's achievements. Otherwise, mercury pressure gauges then measured only down to 0.7 mbar. F. Watkins's wife corresponded with Nicéphore Niépce while his granduncle collaborated with John Dollond. The next year, at the large exhibition in London in the international competition, the pump of Englishman John Frederick Newman (1783 South Londoner Peckham, Surrey-1860 borough in Northwest London of Camden, Middlesex) won with its operations still based on Guericke's invention.¹³¹⁶ The gatherings at major international exhibitions have expanded improvements in vacuum technology at the meetings of inventors and users since the mid-19th century. A meeting at a similar exhibition half a century ago led to the establishment of the International Organization of Vacuum researchers. Some international exhibitions received the adjective "electrical" in the 1880s. For the Slovenian networks, the Electrical Exhibition in Vienna in 1883 was of greatest importance, also because the Slovenian

Jožef Stefan headed it on the technical and scientific side. That same year he became the president of the Electrotechnical Society in Vienna, which



Figure 8-1: Thomas Andrews(* 1813; † 1885)

was founded after the example of a three-year-old society in Berlin. It also joined the vacuum researchers. In 1852, the chemistry professor at Queen's College in Belfast, Thomas Andrews, found that Torricelli's vacuum over the mercury column in the barometer was still better than a vacuum accessible through pumps, as it only contained mercury vapors. Only few of the current pumps reached 3.3 mbar. However, only a few physical experiments could be carried out in Torricelli's vacuum, such as the drop-in dust in a vacuum or the dissemination of the air in a closed balloon, which the Florentine academics set up in a vacuum. Torricelli's vacuum is a result of single extraction of small volumes, which is relatively cumbersome.¹³¹⁷ That is why researchers preferred to pump the vacuum, which Andrews still improved with getters. In 1850, a crystallographer Schröter von Kristelli as a professor of chemistry at the Polytechnic and the Secretary General of the Viennese Academy visited Postojna Cave and an Idrija mine. In Idrija of those times the miners dug up most of the mercury for barometers, so Andrews got ideas for exploring low pressures (Figure 8-1).¹³¹⁸ In 1861 Andrews began to explore

¹³¹⁷ Andrade, 1984, 77.

¹³¹⁸ Andrews, 1889, XXIV, 223–224.

¹³¹⁶ Madey, 1984, 11; Redhead, 1999, 139.

high pressures. He tried to liquefy gases, which were considered "permanent" until then, and began a long-term match to achieve an absolute temperature zero.

Also, Schröter began his research of vacuum after meeting Andrews and testing the early version of Geissler's cathode ray tube. He experimented with a phosphorus steam in a tube, 30 cm long and 2 cm wide, and with the other 40 cm long and 1 mm wide. The distance between the electrodes was 26 cm. After discharging, "the walls were covered with brown-red to gold-yellow thin layer of amorphous phosphorus, which reminded of the colors of thin bodies". He additionally repeated Hittorf's experiments from the year 1865.¹³¹⁹

In 1859, the Parisian engineer Giffard used the principle of dynamic pressure in his syringe or pump on water jets after he demonstrated manned airship powered with a steam engine in Paris. At the same time, Schimper assembled the blower pump, which quickly became established under various names, including as a "sputtering" pump.

8.1.2 Use of Vacuum in Cathode Ray Tube

8.1.2.1 Geissler: the First Usable Cathode Ray Tubes

The vacuum used in steam engines was outside the dominant direction of research in physics in the century between 1760 and 1860. New discoveries at the beginning of the second half of the 19th century re-invigorated the research of vacuum. In the second half of the 19th century, the vacuum was improved in three ways: better sealing in completely glassy systems without rubber and other parts, heat treatment of the glass to remove adsorbed gases, and improved pumps with a liquid piston. More powerful batteries enabled the observation of discharges in a vacuum that inspired Davy and Petrov's attention already in the early 19th century. Davy's battery with 2000 pairs of Zn-Cu elements occupied the space of a huge hall, and Petrov used 100 more pairs at a voltage of around 1700 V. Petrov changed the substance, shape and distance between the electrodes and the pressure in the cathode ray tube. In 1804, he reported from the Petersburg Medical Academy department of

surgery: "When we continue pumping air from the bell and perform five movements of the piston, we see the light in several parts of the bell and in the whole oil delivery device. Lighting is even more pronounced when pumping down to 2 1/2 lines of the ordinary mercury barometer. In subsequent pumping, the shine becomes weaker and ultimately invisible."¹³²⁰

With the support of relatives **Vasilij Vladimirovich Petrov** from Oboyan (Обоянь) in the Kursk gubernia graduated from the Collegium in Kharkov in 1785. Three years later he finished a teaching seminar in St. Petersburg. He was employed as a teacher of physics and mathematics at the Kolyvan-Voskresensk (КОЛЫВАНЬ-ВОСКРЕСЕНСК) mining school in the Siberian city of Barnaul (Барнаул) which was established in 1753. In 1791 he started teaching in the more promising St. Petersburg, and two years later he moved to the Medical Academy of Surgery for the next forty years. In November 1802 he assembled a battery with 2100 Cu-Zn elements and a voltage of about 1700 V. With he obtained the first operative carbon arc-lamp. Between 1810 and 1827, he also led the Physics Cabinet of the Petersburg Academy, and in 1807 he became a full member of the prestigious Petersburg Academy. However, his works published mostly in Russian language were used by Westerners only half of a century after he passed away).

Davy's work was continued by his student Faraday although there might have been some misunderstanding among those two self-taught experimental geniuses. In 1848 Plücker visited Faraday in London and then proceeded where Faraday stayed due to illness. They collaborated closely, as they used the experimental devices of Englishman Gassiot in Bonn and Münster, and important publications were regularly translated on both sides of the English Channel.¹³²¹

With sufficiently high voltage, further progress in the research of the glow discharges required a better vacuum. In 1854, Plücker commissioned his friend Geissler to produce a better glass air pump for exploring discharges in a diluted atmosphere. Right then, Geissler opened a workshop for

¹³¹⁹ Geissler, 1874, 171–173.

¹³²⁰ Bowers, 1998, 64, 67.

¹³²¹ Hittorf, 1869, 5, 202.

scientific instruments in Bonn, which was at the same time a ten-store workroom and a shop. He perfected the old Swedenborg's idea. In the decades following Guericke's and Auersperg's Regensburg experiments, kings still had a decisive role in promoting experiments. Therefore, a member of the Swedish Royal Academy of Sciences Swedenborg (Figure 8-2) first showed his new hydraulic vacuum pump to his king Charles II.

Heinrich Geissler from Igelshieb in Thuringia had a glass workshop at the University of Bonn and then he headed it in the Netherlands for another eight years. In 1854 he returned to Bonn and later joined his workshop with Franz Müller's firm. Geissler's brother was a famous mechanic who made meteorological and other devices in Berlin. H. Geissler began his scientific work with the measurements of the coefficients of linear temperature expansion of materials which he used for a thermometer in which the expansion of mercury and the glass were compensated by one another (Plücker, Geissler, 1852, 238-279). In 1853, he set up a CO₂ extraction apparatus. In 1862 he became the honorary doctor at the University of Bonn. He then compiled a maximum mercury thermometer, modeled on Cassel's devices in London and different from Negreti and Zamboni's tools. Geissler's maximum thermometer was presented to the Berlin Academy by Heinrich Wilhelm Dove. Dove was born in 1803 in Liegnitz and served as a professor at the University of Königsberg (today's Kaliningrad) and later in Berlin. In 1868 Geissler described the light flashed in the cathode ray tubes and in the mercury vacuum of Torricellian tube, which he rubbed with the cat's hair. The lightning lasted for one minute, and its color was dependent on the temperature and on the nature of the gas in the tube. He advised the use of the Davy lamps. He was not yet able to connect his observations with the then known luminescence phenomena. Six years later he published a discussion on the conversion of phosphorus into an amorphous form in the cathode ray tube. Somewhat later, the researchers versed in luminescence and cathode ray tube lightning phenomena finally noticed their resemblances.

Swedenborg used a table with two tall legs holding a closed bell. He connected the steel vessel to the steel tube through which the mercury streamed.

Instead of a solid piston, Geissler also used mercury in a glass tube, and reached the lowest pressure of 0.1 mbar in 1857. His design was in fact the multiply repeated Torricelli's experiment.¹³²² In the first months of 1857, the Geissler's inventions were tested in Plücker's Cabinet of physics in Bonn, where the assistant Wilhelm Heinrich Theodor Meyer (Ludwig Christian Karl Mayer, * February 8, 1820/1825 Michelbach part of Marburg in Hesse (Nassau)) studied the stratification of electric light in September 1857. Geissler also sent one of his cathode ray tube to his brother Friderich Wilhelm Geissler in Amsterdam. Plücker presented the invention to the Rhine Society of Naturalists and physicians, and later to the Society of German Natural History scientists and physicians. In the first two cathode ray tubes which Geissler supplied by the order, the vacuum contained mainly mercury vapor and atmospheric air, but less essential oils, hydrogen and phosphorus. He used electrodes made from platinum. Plücker immediately coined the term "Geissler tube"¹³²³ while the device was described in more detail only by Plücker's assistant W.H. Theodor Meyer next year in Berlin.¹³²⁴ On September 9, 1857, a report was published in the *Kölnischen Zeitung*. Meyer's dissertation was not completed in Bonn but in his native Marburg in August-November 1857. On 21 September 1857 Meyer reported on his achievements to a meeting of German physicians and naturalists in Bonn. Plücker supported him with the demonstrations of his experiments there. Meyer published another book in 1858. In the foreword dated September 1858, Meyer praised Geissler and his publication in *Pogg. Ann.*, but failed to mention Plücker, which was certainly annoying. However, there was a dispute between Meyer and his chief Plücker who had more than enough other enemies in Berlin. Plücker had early recognized the potential of initiated by Geissler and opened by Meyer in Bonn research area, made their own investigations and from it a little later in 1858/59 developed the profitable field of spectral analysis of electrically excited gases. Already before in 1858 he had coined the term "Geißlersche tubes". Meyer opposed his physical views, including Plücker's cautious reserve in

¹³²² Andrade, 1984, 77.

¹³²³ Dörfel, 2008, 202, 204; Plücker, 1857, 88–89; Šubic, Lehrbuch, 1874, 250.

¹³²⁴ Meyer, 1858; Poggendorff, 1865, 153; Redhead, 1999, 139.

interpreting the phenomena observed angered Plücker, who oriented himself on the axiomatic mathematical approach, and thus fueled the conflict. When Meyer came to the public with his writing and the controversial remarks aimed at Plücker, that teacher-student competitive situation was already soured. Meyer had submitted his dissertation on problems of magnetism (completed during his work on glow discharge!) at the University of Marburg instead of Bonn. Meyer went to Marburg or to Berlin and there is nothing known about any of his later scientific successes. The conflict of priority appeared also at the Faculty of Philosophy in Bonn in 1868.¹³²⁵



Figure 8-2: The first Guericke pump: one of the observing nobles could be Carniolan Auersperg.¹³²⁶

Johann Wilhelm Hittorf was born in a trading family in Bonn, where he studied chemistry and physics and received his Ph.D. from Plücker in 1846. From 1852 to retirement due to ill health in 1889 he was a professor at Münster, where he also died.

In 1858, Plücker observed the influence of the lowering of pressure and the magnetic field on discharges in Geissler's tubes. After 1860, Plücker's research was continued by his student Johann Hittorf, professor of the Academy in Münster who proved to be much more obedient than Meyer.¹³²⁷

The properties of "cathode rays" were studied in the 19th century with Ruhmkorff's induction

apparatus¹³²⁸. With a small DC voltage in the copper wire of the primary coil, it induced a giant alternating voltage on a secondary coil, which had a well-insulated thin conductor up to 500 km in length. With the current of two Bunsen batteries, the rabbit could be killed.

Clausius had initially an induction apparatus on polytechnics in Zurich which produced only 3 to 4 cm long spark. In 1857, he acquired a Ruhmkorff's inductors, with which he could obtain 27 cm long sparks. In 1862, Clausius acquired a large 800 mA electromagnet. Ruhmkorff's inductors, which cost 1000 francs, were also located elsewhere in German-speaking countries before 1861, for example, at the Polytechnic in Karlsruhe and at the University of Heidelberg.¹³²⁹ In the following year at the Ljubljana grammar school Mitteis purchased Ruhmkorff's inductor after he closely followed the development.

German **Heinrich Daniel Ruhmkorff** was born in Hannover, but he opened his store of scientific tools in Paris in 1839. He started to produce his famous inductors in 1848. In 1836, a similar device was already invented by priest Nicolas Callan (1799-1864) as an Irish university professor of natural sciences in 1836-1837 after Callan learned all about Galvanic and Voltaic discoveries during his theological studies in Rome.

Plücker acquired most of his experimental equipment in Paris. On the other hand, Plücker and Geissler supplied devices for the study of "cathode rays" to Gassiot and Töpler in Graz who were former Hittorf's students. In 1869, Hittorf launched a 16 cm long spark in the air with Ruhmkorff's apparatus. At that time, Geissler from Bonn sent "beautiful large tubes" to the new Habsburg physics institute in Graz. In them, Boltzmann observed the influence of the magnet on electrical charges in 1886 and 1887. From a small Ruhmkorff apparatus, they obtained 1 cm long sparks at a pressure of 1 mm Hg.¹³³⁰ Ruhmkorff's apparatus was also used by Boltzmann's teacher Stefan in Vienna.

¹³²⁸ Jungnickel, McCormmach, 1986, 1: 199; Ganot, 1886, paragraphs 921, 923.

¹³²⁹ Hittorf, 1869 202; Jungnickel, McCormmach, 1986, 1: 199-200, 222, 236.

¹³³⁰ Boltzmann, 1909, 89.

¹³²⁵ Dörfer, 2006, 28-30, 35-36, 44.

¹³²⁶ Schott, 1657, 445.

¹³²⁷ Sparnaay, 1992, 63-66.

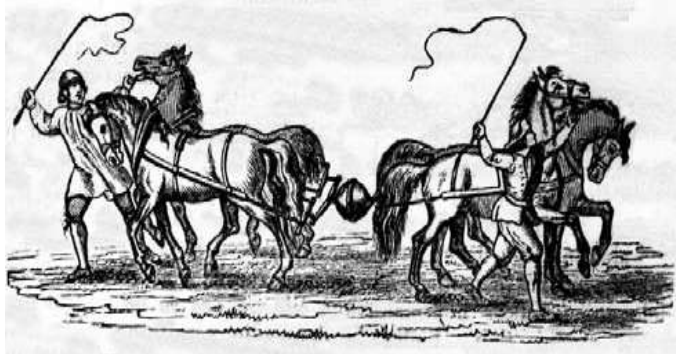

Figure 8-3: The experiment of Guericke and prince Auersperg of Carniola with Magdeburg hemispheres conceived by the professor at the Zagreb Higher Real School Slovenian Ivan Tušek (* 1835; † 1877) two centuries after the first experiments in his translation of Schoedler's *Physics* published in Braunschweig in 1865.¹³³¹

In 1867/68, Magdeburg hemispheres were re-acquired at the Gymnasium in Ljubljana. The following year, the curious Slovenes could read the description of Guericke's experiment in the native language: "... These hemispheres, which previously had fallen apart from themselves, fell tight one upon another, so that the six pairs of horses fused by rings from each other side, could not break apart the hemispheres" (Figure 8-3).¹³³² Unfortunately, the reader did not learn much about Auersperg's merits in Guericke's experiment. The lack of proud memories always been a disaster in Carniola. Unfortunately, Carniolan contribution to the early vacuum technique slowly sank into oblivion.

Already Guericke (1672), Boyle and Hooke (1658) found that vacuum does not interfere with electrical forces. With the introduction of Geissler's electrical glow discharges in diluted gases, discharges in vacuum became fashionable electricity exploration. In a few years, they have been developed into a teaching aid. Geissler put metal pipes of platinum glass in the cathode ray tubes. His pump did not have a dead end in its operation and could reach a pressure down to 0.011 mbar. In 1862, Töpler at the University of Jena thus processed the Geissler pump so that it no longer needed shut-off pipes. This has reduced the available pressure fourteen times. In August 1868, Töpler was elected as a full-time professor of

experimental physics in Graz. On 17 July 1876, he was a groomsman at a wedding of his collaborator Boltzmann and Boltzmann's former student, the half Slovenian Jetti in Graz.

Hermann Johann Philipp Sprengel from Schillerslage by Hanover studied in Göttingen since 1855 and received his Ph.D. in Heidelberg in 1858. The following year he became Assistant of Benjamin Brod at the University of Oxford. From 1863 he studied in London as a chemist at the Royal College of Chemistry and at hospitals Guys and St Bartholomew's. In the latter, chemistry lecturer William Olding enabled him to explore, which he crowned with his first pump in which he exhausted air from the tube with repeated successive mercury drops. The pump was immediately put into service, as Graham used it in 1866 to explore gas diffusion. At the University of Heidelberg in 1869, Bunsen compiled a "Wasserluftpumpe" from Sprengel's pump, developed by Gimingham and others in many versions. In 1865 Sprenger researched at the London chemical factory. From 1870 he lived as a private person, and eight years after he was selected in the RS. In 1881, he published a discussion on the vacuum pump in London and New York on 16 pages of large format. He died in London.

Berliner experimental physicists Jakobi, Steiner, Poggendorff and Magnus did not support the surveys of "cathode rays" of Bonn professor Plücker and his student Hittorf. The dispute emerged in the years 1832-1834, when Plücker was an associate professor in Berlin; Poggendorff later loved to irritate Plücker which might have propelled Meyer's mutiny. Geissler presented his pump at a gathering of German naturalists in Giessen, where his performance was watched by Poggendorff, editor of the leading German physical journal *Ann. Phys.* In September of the same year, Poggendorff presented his version of the mercury pump in London's *Phil. Mag.* Poggendorff described the idea of a pump on mercury as "very old, just as old as the pump itself. We have put Geissler as the inventor because he was the first to put together a practically usable pump."¹³³³ He praised Swedenborg's invention, thereby reducing the significance of Geissler's and

¹³³¹ Tušek, 1869, 94 figure 111; Schoedler, 1865, 82, figure 111.

¹³³² Tušek, 1869, 93–94.

¹³³³ Poggendorff, 1865, 153, 158; Wüllner, 1870, 365–366.

Plücker's surveys.¹³³⁴ Of course, Plücker also had followers; among them was Wüllner as his private assistant since 1865, whose textbook has been used by Slovenian Stefan as a source of information for his famous radiation law.

Due to a dispute between physicists from the Prussian universities in Berlin and Bonn, Plücker's work was recognized and translated in England more than in Germany. Thus, there was no proper connection between Plücker's and Hittorf's cathode-ray light surveys and concurrent studies of the Kirchhoff-Bunsen spectral analysis at the University of Heidelberg. Initially, they explored only the spectra of vapors of ordinary metals and did not notice that the spectrum of the same gas could change under different conditions of annealing. They used a burner that was compiled by Bunsen a year ago. Kirchhoff reported on his research for the first time to Berlin's academics in October 1859, of course, without mentioning Plücker. Explorations of glowing vapors in the spectroscope and in cathode ray tube tubes were only linked in the 1870s when Crookes successively achieved valuable results in both areas. The German Hermann Sprengel described a pump in which mercury droplets covered and removed parts of gas in glass pipes in London in 1865.¹³³⁵ The new process was slower than Geissler's, but it allowed multiple pumping and therefore a better final vacuum down to 0.1 Pa.¹³³⁶

8.1.2.2 British Vacuum Researchers and Crookes

In 1873 Crookes assembled a radiometer to study the amount of radiation. He linked his findings to the research of vacuum tubes and in 1876 he designed the theory of the fourth aggregate state of matter. During this time, he participated in spiritual research,¹³³⁷ which surely influenced the boldness of his hypothesis.

His pioneering method was initially accepted as evidence of the "cathode ray" pressure. Between 1873 and 1876 he was very popular in scientific journals and challenged the controversy between Maxwell and Osborne Reynolds. Unfortunately,

¹³³⁴ Swedenborg, 1722; Gren, 1791; Poggendorff, 1865, 151; Andrade, 1984, 81.

¹³³⁵ DeKosky, 1984, 85.

¹³³⁶ Madey, 1984, 14; Friedel, Israel, Finn, Israel, Finn, 1986, 51, 53.

¹³³⁷ Brush, Everitt, 1969; Brush, 1976, 211.

the difference in the pressure that propels the radiometer comes from temperature differences and does not measure pressure of waves of light at all. Crookes had other ambitions too: only in the mid-1880s Crookes finally abandoned the program designed to achieve his absolute vacuum.

8.2 Slovenian Vacuum Researchers after the Invention of the Cathode Ray Tube

8.2.1 *The Equipment of Slovenian High Schools during the Great Progress of Vacuum Technology*

In the second half of the 19th century in Slovenia there was no teaching facility that would exceed the upper secondary level. Therefore, some of Slovenian schools, especially the Ljubljana gymnasium, were among the best in the monarchy of that level. They maintained with well-equipped cabinet of physics in which they did not miss any devices for demonstrating the vacuum. Kersnik's and Mitteis' inventory lists of the cabinet of physics in Ljubljana indicate on average about forty devices connected with vacuum and overpressure in the middle of the 19th century. The devices were massive and mostly made of bronze, so that they survived a century of demonstration experiments and today still arouse admiration at the Slovenian School Museum in Ljubljana, where they are waiting for a suitable exhibition space. The experimental tools devices connected with vacuum and overpressure were noted according to the censuses of higher studies and later Grammar school in Ljubljana during a century between Erberg (1755) and Mitteis (1866). Among them, by far the most expensive were the double-sided air pump valued at 147 florins or 157 florins 50 kreuzers which was acquired in 1858 and the older model of the steam engine (Table 8-1).

The schools outside Ljubljana also liked to buy gauges. Thus, a metal barometer was purchased as the "Bourdon tube" at the Gymnasium in Koper in 1875, ten years after the Gymnasium in Ljubljana. It measured the deflection of the elastic element due to external pressure (Figure 8-4). Eugène

Table 8-1: Vacuum devices at the Ljubljana Gymnasium in the 19th Century

Equipment	Year of purchase	Manufacturer	Price in fl: kr
Barometers:			
designed for travel with nonius	1809–45	Hanaczik	28:35
designed for travels by Saussure	1809–45		12:60
Metallic of Bourdon	1865		40: 0
On spread (syphon) with nonius	before 1809		
On spread, thermometer and nonius	1861		36: 0
Barometric tubes	1809–1845, 1853	Veht	5:77
two barometers for exercises	1809–45	Fanzoy (Oswald Fanzoi, Fanzoj's fabric of better sort linen in Ljubljana which mostly just colored imported linen)	
With receptor	1853		
Gas bridge of Double bottle system made of tinplate (Gasbrücke aus Weißem Bleich)	1858		
With scale and thermometer	1861		
Barometric Vessel in leather holster of mechanic Heinrich Kappeller, who ran a workshop in Viennese Bezirk Margareten	1862		
Bourdon's metallic	1865		
Aerometers:			
atmometer made of iron plates	1809–45	Freyberger	
Design of William Nicholson (1753-1815), made of brass	1809–45	Riebler	1:57
with glass tube and stative by design of the Viennese Polytechnic professor Paul Traugott Meißner (*1778 Mediasch in Romania; † 1864 Vienna)	1809–45	Hanaczik	42: 0
Carl Friedrich Christian Mohs's (1773–1839), of brass	1809–45	Hanaczik	2:10
Antoine Baumé's of brass	1809–45	Hanaczik	1: 5
Antoine Baumé's of glass, wood, silver and copper	1809–45	Hanaczik	
Recipients: 2 air-tight; 3 common made of glass	1809–45	Samassa	
Models of steam engines:			
Simple	before 1809		157:50
Watt's	1867		15: 0
Pumps:			
on air, with horizontal scroll	before 1809	Samassa	
On air, with two vertical elbows	1809–45	Huck	
Double-sided, air	1858		147: 0
on pressure and traction	1809–45	Samassa	
air rifle with pump	1809–45	Samassa	
Realsch's devices, using water	1809–45	Hanaczik	
pneumatic	1809–45	Hanaczik	4:20
on lever	before 1809		
to pull	1809–45	Hess and Tischler	
on lever (model)	1858		8:40
On pressure (model)	1858		8:40
Motion in vacuum:			
Device sealed with resin	1755		
Roller for demonstration of falling	1809–45	Hanaczik	5:25
Experiments: Mariotte's			
Papin's pot	1809–45	Hanaczik	7:35
Heron's ball	1809–45	Hanaczik	14:70
Heron's sprinkle	1755		
Magdeburg hemisphere	1755, 1809, 1868	Samassa	
endless Archimedes' screw	before 1809		
Geissler's cathode ray tubes with a stative	1863		12:80
fluorescent tubes	before 1845		7: 0

Table 8-2: Vacuum devices Koper and Klagenfurt in the second half of the 19th century

Name of equipment	Year of purchase	Grammar school in_
Simple graduated barometer	1852	Celovec (Klagenfurt)
Fortin' barometer	1853	Celovec
Tube with mercury	Before 1858	Koper
aneroid barometer	1863	Koper
Nicholson's barometer	1864	Koper
aneroid barometer	1870	Celovec
Device for demonstration of Torricelli's law	1871	Koper
aneroid barometer	1872	Celovec
Fortin's barometer, »Bourdon's barometer«, manometer	1875	Koper
aneroid barometer with thermometer	1893	Koper
Barometer	1895	Koper
model of aneroid, gasometer	1901	Koper

Bourdon (1808 Paris–1884 Paris) patented his aneroid metallic tube pressure gauge in 1849.

Let us look at the pressure gauges in inventory and censuses in Koper and Klagenfurt in the second half of the 19th century.

During the period of rapid development of vacuum research after to the invention of the cathode-ray tube the schools in Slovenian lands supplemented their cabinet of physics with more modern manometers in the second half of the 19th century. On September 22, 1870, at the first independent exhibition of teaching aids in Ljubljana, the professors of "imperial royal c.kr. teacher preparatory" displayed their "physics apparatus in images". Among other things, they also displayed images of "gasometer and gas container".¹³³⁸

In the Slovene ethnic territory, they were interested in cathode ray tubes discharges at an early age. The cabinet of physics were not intended for students only. The Bohemian German Mitteis, professor of physics in Ljubljana from 1853 to 1866, director of gymnasium and for some time also the director of Ljubljana real school, demonstrated his most interesting purchases in front of the selected company of educated locals in the Carniolan Museum in Ljubljana. The physicist Thomas

¹³³⁸ Günter Reich, Wolfgang Gaede, v Redhead (ed.), Vacuum Science and Technology, Pioners of the 20th Century, History of vacuum science and technology, Vol. 2, AIP Press, 1994, 53; Lafferty, 1998, 381.

Schrey, Mitteis's substitute (suplent) teacher, supplemented Mitteis' lecture on the development of a stereoscope with the introduction of the latest methods for measuring the magnitude of the electrical spark. Schrey was born in German speaking family in Logatec in 1830. Between 1862 and 1870 he was the director of the Ljubljana Real School where he taught physics as Peternel's and Hugo Ritter von Perger's superior. Schrey also taught physics and chemistry in Ljubljana Sundays trade school connected with his Real School. The Slovenian Carniolan national politics was not his favorite, so, Schrey went to lecture in mathematics and physics at the Real School of Klagenfurt where he lived in Große Theatergasse no. 54 of south part of downtown Klagenfurt in 1876. Like his friend Dežman for Carniola, Schrey used the barometers to update a quarter of century earlier Prettnner's estimated heights of the hills in Carinthia up to June 1876. Like Dežman and Mitteis, Schrey measured earthquakes in 1897. Schrey died in Annabichl (Anapigelj) in southern part of Klagenfurt in 1909.

After Schrey left for Real School directorship, in the school year 1862/63 Mitteis acquired five Geissler's cathode ray tube for the students of Physic in Gymnasium in Ljubljana (Figure 8-4). He acquired Ruhmkorff's induction apparatus for 120 fl, which exceeded half of the annual grants of the cabinet of physics.¹³³⁹ He bought another

¹³³⁹ Mitteis, 1866, 61.

strong magnet with three lamellas and raised it to 7 kg.

In 1867/68 Mitteis's successor Jakob Rumpf, curator of the Cabinet of physics of the Gymnasium in Ljubljana, acquired "electromagnetic apparatus for rotating Geissler's tubes".¹³⁴⁰ It was Geissler's refinement of de Rive's electromagnet, adapted for twisting and rotating of the light arc in Geissler's cathode ray tube.¹³⁴¹

Item No.	Description	Quantity	Price
31	Lehrmittel zur Darstellung des Magnetismus	1	1.15
32	Lehrmittel zur Darstellung der elektrischen Induktion	1	1.15
33	Lehrmittel zur Darstellung der elektrischen Leitung	1	1.15
34	Lehrmittel zur Darstellung der elektrischen Zersetzung	1	1.15
35	Lehrmittel zur Darstellung der elektrischen Erzeugung	1	1.15
36	Lehrmittel zur Darstellung der elektrischen Wirkung	1	1.15
37	Lehrmittel zur Darstellung der elektrischen Schwingung	1	1.15
38	Lehrmittel zur Darstellung der elektrischen Entladung	1	1.15
39	Lehrmittel zur Darstellung der elektrischen Entladung	1	1.15
40	Lehrmittel zur Darstellung der elektrischen Entladung	1	1.15
41	Lehrmittel zur Darstellung der elektrischen Entladung	1	1.15
42	Lehrmittel zur Darstellung der elektrischen Entladung	1	1.15
43	Lehrmittel zur Darstellung der elektrischen Entladung	1	1.15
44	Lehrmittel zur Darstellung der elektrischen Entladung	1	1.15
45	Lehrmittel zur Darstellung der elektrischen Entladung	1	1.15
46	Lehrmittel zur Darstellung der elektrischen Entladung	1	1.15
47	Lehrmittel zur Darstellung der elektrischen Entladung	1	1.15
48	Lehrmittel zur Darstellung der elektrischen Entladung	1	1.15
49	Lehrmittel zur Darstellung der elektrischen Entladung	1	1.15
50	Lehrmittel zur Darstellung der elektrischen Entladung	1	1.15
51	Lehrmittel zur Darstellung der elektrischen Entladung	1	1.15
52	Lehrmittel zur Darstellung der elektrischen Entladung	1	1.15
53	Lehrmittel zur Darstellung der elektrischen Entladung	1	1.15
54	Lehrmittel zur Darstellung der elektrischen Entladung	1	1.15
55	Lehrmittel zur Darstellung der elektrischen Entladung	1	1.15
56	Lehrmittel zur Darstellung der elektrischen Entladung	1	1.15
57	Lehrmittel zur Darstellung der elektrischen Entladung	1	1.15
58	Lehrmittel zur Darstellung der elektrischen Entladung	1	1.15
59	Lehrmittel zur Darstellung der elektrischen Entladung	1	1.15
60	Lehrmittel zur Darstellung der elektrischen Entladung	1	1.15
61	Lehrmittel zur Darstellung der elektrischen Entladung	1	1.15
62	Lehrmittel zur Darstellung der elektrischen Entladung	1	1.15
63	Lehrmittel zur Darstellung der elektrischen Entladung	1	1.15
64	Lehrmittel zur Darstellung der elektrischen Entladung	1	1.15
65	Lehrmittel zur Darstellung der elektrischen Entladung	1	1.15
66	Lehrmittel zur Darstellung der elektrischen Entladung	1	1.15
67	Lehrmittel zur Darstellung der elektrischen Entladung	1	1.15
68	Lehrmittel zur Darstellung der elektrischen Entladung	1	1.15
69	Lehrmittel zur Darstellung der elektrischen Entladung	1	1.15
70	Lehrmittel zur Darstellung der elektrischen Entladung	1	1.15
71	Lehrmittel zur Darstellung der elektrischen Entladung	1	1.15
72	Lehrmittel zur Darstellung der elektrischen Entladung	1	1.15
73	Lehrmittel zur Darstellung der elektrischen Entladung	1	1.15
74	Lehrmittel zur Darstellung der elektrischen Entladung	1	1.15
75	Lehrmittel zur Darstellung der elektrischen Entladung	1	1.15
76	Lehrmittel zur Darstellung der elektrischen Entladung	1	1.15
77	Lehrmittel zur Darstellung der elektrischen Entladung	1	1.15
78	Lehrmittel zur Darstellung der elektrischen Entladung	1	1.15
79	Lehrmittel zur Darstellung der elektrischen Entladung	1	1.15
80	Lehrmittel zur Darstellung der elektrischen Entladung	1	1.15
81	Lehrmittel zur Darstellung der elektrischen Entladung	1	1.15
82	Lehrmittel zur Darstellung der elektrischen Entladung	1	1.15
83	Lehrmittel zur Darstellung der elektrischen Entladung	1	1.15
84	Lehrmittel zur Darstellung der elektrischen Entladung	1	1.15
85	Lehrmittel zur Darstellung der elektrischen Entladung	1	1.15
86	Lehrmittel zur Darstellung der elektrischen Entladung	1	1.15
87	Lehrmittel zur Darstellung der elektrischen Entladung	1	1.15
88	Lehrmittel zur Darstellung der elektrischen Entladung	1	1.15
89	Lehrmittel zur Darstellung der elektrischen Entladung	1	1.15
90	Lehrmittel zur Darstellung der elektrischen Entladung	1	1.15
91	Lehrmittel zur Darstellung der elektrischen Entladung	1	1.15
92	Lehrmittel zur Darstellung der elektrischen Entladung	1	1.15
93	Lehrmittel zur Darstellung der elektrischen Entladung	1	1.15
94	Lehrmittel zur Darstellung der elektrischen Entladung	1	1.15
95	Lehrmittel zur Darstellung der elektrischen Entladung	1	1.15
96	Lehrmittel zur Darstellung der elektrischen Entladung	1	1.15
97	Lehrmittel zur Darstellung der elektrischen Entladung	1	1.15
98	Lehrmittel zur Darstellung der elektrischen Entladung	1	1.15
99	Lehrmittel zur Darstellung der elektrischen Entladung	1	1.15
100	Lehrmittel zur Darstellung der elektrischen Entladung	1	1.15

Figure 8-4: Geissler's glow discharge tubes filled with dilute gas in Mitteis' inventory list at the Gymnasium in Ljubljana at the end of the second semester, on August 1866. Geissler's tubes and their stands were listed as 62nd and 64th device for experiments in electricity.¹³⁴²

At the Grammar School in Koper, the docent of mathematics and physics Stefano Hamerle from Rijeka Civil Technical School (Civica Scuola

¹³⁴⁰ Journal of Grammar school (Izvestja Gimnazije) Ljubljana, 1868.
¹³⁴¹ Ganot, 1886, paragraph 928, 892–893.
¹³⁴² Zgodovinski arhiv Ljubljana (ZAL), akc. fond (Accessory fond) 1, archival unit (technical unit) 48.

Tecnica) was employed on 7. 10. 1867. He purchased the first Geissler's electrical glow discharges in diluted gases together with Ruhmkorff's inductor in 1870¹³⁴³ and the second one in 1897. The graduate of Viennese Polytechnic engineering Orlando Inwinkl (Inwinkel, * 1880 Barban (Barbana) in southern Istria; † 1936 Colombes in the northwest suburb of Paris) became the supplied professor of mathematics and physics in Koper on 12. 10. 1904. In that time the Grammar school library in Koper had many books about physics published in 18th century and later:

- Algarotti, Francesco, Dialoghi sopra la luce, i colori e l'attrazione. Napoli 1752.
- Bammacari, Niccolò (Bambacari, * Napoli; D. 1759/1792), Tentamen de vi electrica. Napoli 1748.
- Barletti, Carlo, Nuove sperienze elettriche secondo la teoria di Franklin e le produzioni di Beccaria. Milano 1771.
- Beccaria, Giambattista, Dell' Elettricismo. Lettere. Bologna 1758.
- Beccaria, Della Elettricità terrestre atmosferica a cielo sereno. Osservazioni. Torino 1775,
- Bošković, De solis ae lunae defectibus. Venetiis 1741.
- Franklin's antagonist Brisson, Mathurin Jacques (1723–1806), Trattato elementare, ovvero, Principi di fisica fondati sulle nozioni più certe tanto antiche, che moderne, e confermati dall'esperienza. Translated from French by Felice Fontana's collaborator Dr. Gaetano Cioni (1760 Firenze-1851 Firenze). Venezia: Lorenzo Basseggio, 1799.
- Genuensis (Genovesi, 1713–1769 Napoli), Anton & Fergolas, Nicolo (Catholic mathematician, 1753 Napoli-1824 Napoli), Elementa physicae experimentalis... Accedunt nonnullae Dissertationes physico-mathematicae conscriptae a Nicolao Fergola. Venetiis 1781 (incomplete).

¹³⁴³ Yearbook (Journal of Grammar school, Izvestja Gimnazije, Atti dell' I. R. ginnasio superiore di Capodistria) Koper, 1868: 54-55; 1870: 52.

- Giovanni Battista da San Martino (Capuchin priest philosopher), *Opere. Meteorologie, ricerche fisiche, etc.* Venezia 1791-95.
- Grandi, Guido, *Instituzioni meccaniche.* Venezia 1750.
- Mach, E., *Populär-wissenschaftliche Vorlesungen. Mit 60 Abbildungen.* Leipzig 1903 as the newest physics book in old collection in Grammar school Koper.
- Musschenbroek, P., *Elementa physicae. Opera et studio Antonio Genuensis (Genovesi).* Venetiis 1761.
- Nollet, *Fenomeni elettrici.* Venezia 1750.
- The exiled Italian patriot Pizzarello, Antonio (1846 Koper-1933 Macerata), *La Coesione nei liquidi illustrata per mezzo del calore che essi acquistano e perdono nel riscaldarsi o nel raffreddarsi.* Macerata: Stabilimento Tipografico Mancin 1880.
- Poggendorf's *Annalen der Physik und Chemie.*
- Vlacovich, *Elementi di fisica sperimentale.* Trieste 1880 & 1888.

In 1906/1907, Orlando Inwinkl as curator boldly complemented the Koper collection with Luigi Palmieri's (1807–1896 Naples) induction apparatus, the didactic set of Geissler's cathode ray tubes, six different Geissler's tubes for electrical glow discharges in diluted gases, a collection of six

Crookes cathode ray tubes, radiometers and the special Crookes cathode ray tube to show the shadow of "cathode rays" behind a Maltese cross. Inwinkl bought Hittorf's cathode rays tube and two X-rays tubes.¹³⁴⁴ Later, Inwinkl taught in Trieste, became a socialist antifascist leader in Monfalcone Partito Socialista Italiana (PSI) in April 1913, director of the fabric of agricultural machines in Windsheim of Bavaria. Chased by the Nazis, he left for France and Switzerland in 1931.

Most of Inwinkl's Koper experimental tools were designed to study "cathode rays" in the Geissler

tube. His Ruhmkorff device was used for a voltage source of several kV, and the magnet was used to

Ivan Šubic from Poljane above Škofja Loka attended the Grammar School in Ljubljana between 1867 and 1875. He studied natural history and mathematics in Vienna, and he listened to Stefan's Viennese lectures for the first time in 1878. He completed the qualification exam in 1881, and in the same year he was employed at the Mahr's Trade School in Ljubljana as a substitute (suplent) teacher. I. Šubic later taught in the Real school and gymnasium in Ljubljana. In 1888, he received a lengthy leave to study at the Technology Crafts Museum in Vienna, where he also visited several other schools and art academies. In August 1888 he became a teacher and head of a newly established professional school for woodworking, and a professional school for artificial embroidery with sewing in Ljubljana. After the merger of both schools, he became director of the State Craft School in 1911. This later got its new higher departments of construction and mechanics, and in 1920/21 it was rearranged into a technical high school. Between 1890 and 1907, I. Šubic was a consultant to the municipality of Ljubljana and led the construction of a plumbing and the electricity power plant as the head of the management board of the municipality. Between 1898 and 1901 he was a Member of Parliament for Kranj and Škofja Loka. As a longtime member of the Slovene Matica (SM), together with Fran Levec, he became head of the SM department of books between 1904 and 1911. From 1904 he was the supervisor of the Slovenian continuing arts schools in Carniola, Styria and Primorska (Littoral), and in 1922 he became a senior supervisor for trade and craft education. For seventeen years, he was a conservator with the Central Commission for the Protection of Artistic and Historical Monuments. In addition to the book on electricity, he published numerous natural science works in the Ljubljana School report, Ljubljana Zvon journal and in the Letopis (Yearly) of SM.

deflect the rays. Three to four cells in the Grove Zn-Cu battery provided a sufficient current that could induce higher voltages in the Ruhmkorff coil

¹³⁴⁴ Inventory Koper, no.265, 268; Journal of Grammar school (Izvestja Gimnazije) Koper, 1897; 1905: 37-39, 44, 1907, 61; 1908, 56.

than in the strongest Leyden jar.¹³⁴⁵ The new Ruhmkorf's inductor finally proved to be better than the apparatus of the previous century, just like the vacuum pumps finally offered better experimental facilities compared to barometers, steamboats bettered sailing-boats capabilities or planes replaced balloons.

Ruhmkorf's inductor was necessary for experiments with Geissler's cathode ray tubes. A set of more than ten Geissler tubes of various shapes and a Ruhmkorff induction apparatus were later acquired by the Lower Real school in Kočevje in 1872, which developed into a higher Real school between 1908 and 1911.

Soon after Geissler's invention, the cathode ray tubes became the subject of secondary school physics. Then high school professor could be more successful than today in the fundamental experimental physics.

8.2.2 *Šubic's Research on the Transmission of Electricity in Gases at the University of Graz*

Ivan Šubic's older relative from Poljanska Dolina S. Šubic was an associate professor at the University of Graz between 1869 and 1902. From Reitlinger and Clausius' (1858) works S. Šubic supposed that the average free path of the molecule is inversely proportional to the density of the medium. However, Š. Šubic wrongly concluded that rare gases better translate electrical and thermal disorders compared to the denser ones. The claim was contrary to Maxwell's kinetic theory from 1859 and 1860, according to which the thermal conductivity does not depend on the pressure and density of the gas, down to the low pressures where no significant interaction between the surface and the gas remains. In 1860 in Berlin Magnus and a decade after him Stefan in Vienna confirmed Maxwell's assumption.¹³⁴⁶

S. Šubic has purchased several Geissler tubes among eighteen electromagnetic instruments for his collection of cabinet of physics in Pest in 1858/60, only four years after the invention and three years before Mitteis in Ljubljana. In his high school textbook Šubic only mentioned the "superb"

electric current in the emptied tube, without describing an experiment with Geissler's cathode ray tube. Considering the experimental orientation of his textbook, we assume that between 1872 and 1874 Šubic hesitated with his opinion about effects in Geissler tube. Šubic's and Hittorf's theory of electrolysis was based on the movement and collision of molecules. S. Šubic extended his similar findings to gases. He was the most interested in the events in the vacuum tube with the electric voltage applied at the extremities. Šubic's velocity of the collisions between the molecules, the voltage, the conductivity, and the spark length were inversely proportional to the gas density in the vacuum tube; therefore, a rarer gas obtained the higher the rate of propagation of molecular collisions, better conductivity and greater luminosity.¹³⁴⁷

The above findings at least partly contradicted the modern kinetic theory that developed in the late 1850-s. The thermal conductivity of gases does not depend at all on its pressure and its density over a wide area, until at low pressures there is no longer significant interaction between surface and gas. In 1862 Šubic was still not aware of Maxwell's theory of the conductivity of gases from 1859-1860, which Clausius corrected in 1862, although Šubic should have known Magnus measurements which supported Maxwell's ideas.¹³⁴⁸

Of all the phenomena in the Geissler tube, Šubic was most interested in "stacking of electric light". He must have assumed that it was a spark of continuous discharge in gas. In 1876, Hittorf considered that cracking was caused by voltage, too weak to produce constant light. Gassiot in 1863, Stokes in 1864, de la Rive in 1867, and Wiedemann in 1872 and 1867 opposed Hittorf's opinion.¹³⁴⁹

According to Šubic, the gas in Geissler tube radiates the light due to heating during transmission of electricity caused by electrical resistance or internal friction. Šubic summed up Reitlinger's opinion, confirmed by spectral analysis. The conductor should be brighter as its electrical resistance turns greater. Šubic and most others thought that there were no chemical

¹³⁴⁷ Šubic, Lehrbuch 1874, 345; Šubic, Grundzüge, 1862, 106, 113.

¹³⁴⁸ Brush, 1976, 84.

¹³⁴⁹ Šubic, 1862, 106; Hittorf, 1889, 181.

¹³⁴⁵ Ganot, 1886, paragraph 849, 800, 803.

¹³⁴⁶ Šubic, 1862, 113.

reactions in Geissler tubes, or they were at least extremely slow. According to Šubic, the mean free path of particles during transmission is inversely proportional to the density of gas, and the mass of the particles is inversely proportional to the square of their velocity.

Both equations were derived from kinetic theory. In gases the resistance is much lower than in the liquids, where according to Šubic the second claim does not apply. The speed of the particles in denser liquids is greater than the speed in the rarer ones, if the radius of the particles in denser liquids is larger or equal to the radius of the rarer ones.

Šubic explained the dark area along the cathode of the Geissler tube by the spread of the collisions between the molecules which in Šubic's theory was an electric current itself. Immediately at the source of the motion in the cathode, there cannot yet be enough collisions with the gas molecules in the vacuum tube to produce any observable light. The sparkling is observed in more distant parts of the Geissler tube.

Šubic's ideas were much like the Crookes' opinions of 1869. However, he did not write straight that the length of the dark region along the cathode would be proportional to the average free path of the molecules in the gas. The dark area of the cathode is now called by Crookes' name. In the case of normal discharge, where the density of the electric current does not depend on its intensity, Crookes theory is valid. The length of the "dark area" is inversely proportional to the pressure or density of the gas in the tube. At extremely low pressures, the "dark area" can be stretched over the entire tube.

According to Šubic, the gas is concentrated in narrow areas of the Geissler's electrical glow discharges in diluted gases because its volume decreases with the same mass of the gas substance involved. The flow of matter through the tube is therefore continuous because it has no sinks or springs in a pipe with only two electrodes. According to Šubic's opinion, the gaseous contents of the tube are indeed entirely thickened everywhere, and not only in its radiating part.

Similarly, Šubic declared luminosity as proportional to the resistance of the gas in the

tube.¹³⁵⁰ Like the electrolytes, gases should translate electricity with the movement of ions. This is contrary to modern theory, since the ions do not move in the cathode ray tube, while the electrons do.

The modern theory of translation in a vacuum tube is much closer to Hittorf's theory,¹³⁵¹ which offered another different mode of translation in gases ~~when~~ besides the motion of ions. Those motions cause glare in the gas, today we would say transitions between excited states of gas atoms.

Another way of Hittorf's translations had all the characteristics of radiation. Even though Hittorf did not specify that analogy, the events in the Geissler tube are completely like the thermal phenomena that combine translation and radiation. During the time of prevailing Puluž's (1888) theory of the translation of electricity in the diluted gases, Hertz detected electromagnetic waves and finally confirmed Maxwell's theory of the electromagnetic field.

Ten years later, J. J. Thomson showed that radiation and translation in gases cannot be explained simply by the wave itself. The "cathode rays" in the vacuum tube consist of particles to which J. J. Thomson has measured a charge-to-mass ratio. Crookes's presumption of the particle nature of "cathode rays" was victorious against his German opponents, at least for two dozen years until the noble duke de Broglie's wave-particle duality of 1924.¹³⁵²

Šubic's publication from 1862 was created for a whole decade before *the* exploration of Geissler's pipes began to promise the resolution of the problem of electricity and the elimination of the electrical substance without weight.¹³⁵³ Šubic did not say in his work that radiation from the cathode is negatively charged and can be rejected by a magnet.

8.2.3 *Šantel's Vacuum Pump at the Grammar School in Gorizia*

In 1869, the Slovenian Tušek, a professor at the Zagreb Higher School in Zagreb, published a

¹³⁵⁰ Šubic, 1862, 106; Hittorf, 1889, 181.

¹³⁵¹ Hittorf, 1889 157.

¹³⁵² Asimov, 1975, 493.

¹³⁵³ Hittorf, 1889 157.

sketch of a pump with a double cylinder alike Hauksbee's model, which was still the most effective just before the Geissler invention: "We see a glass bell which is named as the connector (recipient); the edge is lubricated with a tallow, and is connected to the plate R, to the so-called pump's panel, so that it does not pass the air through. The panel has the hole in the middle, so that the bell is connected by means of a pipe in relation to both the cylinders D and S, whose pistons are spinning up and downwardly with the help of two toothed bars, wheels and double barrels, thereby diluting the air in the bell. For this, they also need cocks, specially perforated, and flaps (Valve). The valves are devices that start to open themselves, if the air is pressing from one side to the other; and which closes by itself, if the air is pushing from the opposite side. Therefore, it is called the air suction device according to how it is made, either the suction pipe or the pump with the valve (Figure 8-5)."¹³⁵⁴

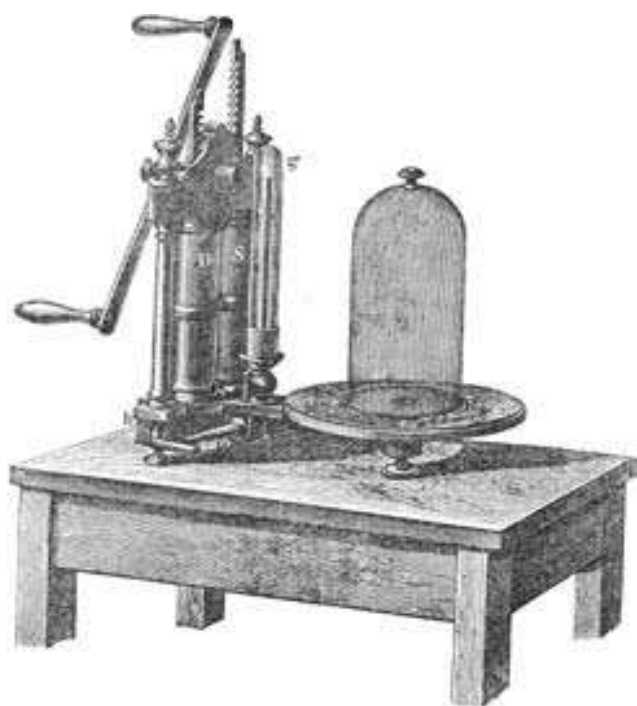

Figure 8-5: Vacuum device which Tušek introduced to the Slovenes¹³⁵⁵

More than two centuries after the invention, the vacuum pump still seemed to be very important to Tušek and Schoedler. For this reason, he kept it on the cover of his translation of Schoedler's physics

¹³⁵⁴ Tušek, 1869, 91–92 figure 108; Schoedler, 1865, page 80 figure 108.

¹³⁵⁵ Tušek, 1869, 92 figure 108; Schoedler, 1865, page 80 figure 108.

in addition to the telescope, the Voltaic battery, the friction device, the electroscope and other tools (Figure 8-6). Slovenes are an ingenious people in the disposal of foreign winds. Therefore, the Slovenes quickly found out that they can improve German vacuum pumps. The greatest achievement after prince Auersperg belongs to Šantel, the Slovenian Styrian in the Coastal Service, who published five discussions in his reports of the Gorizia State High School. He was born in the Slovene family of cottagers in Pesnica by Lučane on Kozjak. From 1865 he studied mathematics and physics in Graz with former Ljubljana professor Hummel and Töpler. In 1872, he became a professor of physics at the Gymnasium in Gorizia. During the First World War, he had to flee to Krško. Šantel's wife, their daughter Avgusta and son Saša were famous Slovenian artists. In 1873 and 1876, Šantel and Boltzmann married two sisters, the half Slovenian Avgusta Aigentler and two years younger Jeti. The family of Šantel spent many holidays together with the family Boltzmann. Šantel's son, Saša, used the help of the Viennese family Boltzmann during his studies in Vienna.



Figure 8-6: Title page of Tušek's translation with a vacuum pump on the right.¹³⁵⁶

¹³⁵⁶ Tušek, 1869, title page; Schoedler, 1865, page 1.

Physicists Šantel and Boltzmann collaborated, as Boltzmann quoted Šantel's mathematical treatment of gas diffusion in 1883.¹³⁵⁷ In the same year, Šantel assembled a vacuum pump, which Boltzmann considered in his experiments with Geissler tubes in Graz in 1886 and 1887.

In 1883, Šantel was mainly interested in vacuum pumps. In 1883, Šantel designed a vacuum pump, which his brother-in-law Boltzmann in Graz used in his research. As a curator of the cabinet of physics Šantel bought Töpler's model of mercury vacuum pump and Edison's bulb in 1882/1883. At the same year, the grammar school of Gorizia student of seventh class Gorizia native Lovisoni Vulmar (abt. 1866 Gorizia) assembled and donated to Šantel's lab the apparatus of the deputy of secondary schools (Oberschulrath) of the German state of Baden the physician Joseph Frick (Frik, 1806-1875) for the convenient cutting of glass tubes, which Šantel certainly used in the construction of his own pump. Lovisoni Vulmar later got his Ph.D. and became a member of the city deputy (*membro della Deputazione comunale*).

Šantel mentioned Torricelli, Töpler and Geissler as inspirators of his vacuum pump. In 1854, Geissler achieved a pressure of 0.01 mm Hg in Bonn with his pump. Töpler was set up in Bonn as a chemist at the Landwirtschaftsakademie Poppelsdorf since 1859. In 1862, he invented a simple barometric air pump for high vacuum without pipes, valves and excess space, which was domesticated at all physical institutes, including Šantel's grammar school lab in Gorizia. Töpler pump could reduce the pressure of the Geissler pump by fourteen times. Between 1868 and 1876, Töpler was a physicist in Graz, while his Physics Institute was the largest in the German language areas at the opening in 1875 which affected the neighboring Slovene lands. Šantel was Boltzmann's every and occasional associate, and Töpler was Boltzmann's groomsman. Thus, Šantel and his teacher Töpler knew each other well too.

Šantel made an air pump for observing discharges in a vacuum. The basic problem of the previous pumps was poor sealing of the valves and the fragility of the thin glass wall of the vacuum tube, which often collapsed under large pressures. Šantel's vacuum pump discharges avoided bad airtight near the cocks and the flimsiness of the

thin glass wall of the vacuum recipient, which often broke due to extended pressure. Šantel's attention was drawn to the physics of high vacuum produced by the draining of mercury along the tube. In it, the electrodes could be strongly charged. Šantel focused his attention to the announcement in a professional physics journal about a high-vacuum achieved by the mercury flow through the tube. In such a vacuum, the electric spark did not discharge prematurely over short distances; so, it was possible to achieve high voltage between the electrodes. In Šantel's pump, the freely descending mercury pumped air from the container. A sufficiently long mercury column broke in the pipe under its own weight with a great noise and left an empty space behind itself. In wide tubes, the high velocity of decreasing liquids in the vertical direction prevented the formation of the bubbles of air.

Šantel warned against the use of rarefied liquids more volatile than mercury, since larger pumps should be used for the pumping out the air with them. In the first experiment, he placed the bottle by the wall which was close to 2 m high. He sealed it with a rubber stopper on the valve and put the glass tubes through it. For his first experiments he chose a 2 mm diameter capillary nearly one foot long and open on both sides. The second tube was shorter and thinner, with the rear pointed side placed in the opening of the first tube.

Šantel connected the freed bottom end of the pump tube to a pot filled with a mercury. Under the lower end of the tube in which mercury dropped, he placed a trap for intercepting. The upper collector was filled with mercury, which quickly flowed downwards. In the pumping tube, mercury was placed up to the height of barometer.

In the second experiment, the recipient was placed in the neck of the bottle with a rubber stopper under 120 cm long horizontal tube. A small opening in the wall near the lower end of the tube was softened with flame. Šantel touched the softened part with a glass rod, sharpened it and removed the top to make a small opening.

The other end of the pipe was immersed in mercury. He placed an empty jar under the recipients of the air pump. When Šantel poured mercury into it, he started pumping. He described the operation of the pump as very good, because

¹³⁵⁷ Boltzmann, 1909, 3: 62, 697.

"man cannot believe his eyes when he watches movement in the tube".

The cylinder made of glass had a diameter of 3 cm and a height of 15 cm. Šantel placed rubber stoppers on the same axis with the two apertures of the cylinder. The space between the stoppers was used for a mercury collector. The upright cylinder was put at a height of 2 m, mounted on a wall or onto a portable wooden stand.

In one of both holes of the bottom stopper, a pipe was laid with strong walls of an inner diameter of 2.5 mm which had 140 cm of length. Through the upper hole above the hose, a pumping hose-tube b was placed with the end in the hole a. Through the second hole of the lower stopper, the mercury supply to the interior spaces was adjusted through the tube c. The pipes c and a had the same shape. Near the end, Šantel had a C-gauge tube with an opening of the width of the hair, which was ending in the interior space A near the upper stopper.

The pump b reached outside the cylinder into the barometer and remained paralleled for further 20 cm. Pipes a and e close to each other emerged from the cylinder A. At the same height, they were soaked in a mercury container B. The pneumatic tube d was closely connected by the rubber tube to the secondary air pump. Šantel was particularly interested in resolving the following puzzles:

- 1) Will mercury flow up from container B to a higher put vessel A?
- 2) In this case, will the flows in the pipe c and in the pipe a balance each other?
- 3) Is the extraction of the air from the recipients fast enough for the practical use of the device?

The first question was affirmatively answered by the start of operation of the pump. The second question emerged from the change in the mercury flow in previous failed experiments. While focusing on the third question, Šantel found that the barometer showed a "zero density" after 1 minute of pumping; with the naked eye it was no longer possible to detect any differences in mercury levels in the arms of barometer.

Šantel solved most of his pumping problems:

- 1) Space A was only slowly filled through the capillaries of pipe of thickness c, so he used thicker pipes.

2) The mercury column core in the pipeline went up into area A and further up into the aperture of the pneumatic tube. The sealed end of a pipe rejected well the striking mercury drops.

3) Due to the dilution of air in room A, the stopper was pressed even further closer to the cylinder, so that the pumping tube was tightly put in the first tube. The stopper separated the space A into two unequal parts and pushed its pressure against each on them. Šantel eliminated problems 2 and 3 by using a vertical shaped glass envelope in the cylinder axis A that impeded the flow of air.

4) The amount of mercury was regulated in the inner vessel when it filled space A to the desired height. The bottom end of the tube was no longer immersed in the mercury collector. The air was no longer running along the tube level and did not change the level of mercury. Šantel recommended using the recipients in the pump. To extract the large spaces of the Geissler's tube, the recipients had to be connected directly to it as the described small dimensions were not useful for pumping out large spaces of Geissler's tubes. He placed 12 inches high, slightly pointed-shaped glass bowl of strong walls in the cathode ray tube. It was sealed by a three times pierced rubber stopper of about 3 cm. In one hole there was a pumping tube from which the curved barometer continued. Šantel placed another barometer in the second tube, and in the third tube he had his recipients. When Šantel introduced and connected all three tubes, the mercury flooded the space in the container above the stopper. This ensured a constant density of air.

The filled recipient's tube had a U-shape with a longer capillary of 76 cm long. The end of the capillary touched the mercury level, which filled half of the container. The tube reached the surface itself without being sunk. In the end, it was linked to recipients. The smoothness and level of the mercury was controlled by a steel wire in a stopper which was carrying a steel cylinder. The steel cylinder usually floated above the surface of mercury, but Šantel could have it sunk together with steel wire to regulate the level of Hg in the U-tube. The pump was described in five points.¹³⁵⁸

Šantel pumped the air from one receiver. The pump was initially manually loaded and adjusted

¹³⁵⁸ Šantel, 1883, 28, 35.

to the size of the long flexible piston. In his late thirties, the professor Šantel did not find the work particularly tiring, as he could rest in the meantime. A mercury piston pumped air from the vessel. The pump could be easily assembled, and the glass tube was easily bent in the fire. Šantel mutually connected all parts with rubber stoppers and Šantel easily replaced them if some unhappy falling or fracture happened. The price was not high, and the apparatus can be completely disassembled and cleaned. Unfortunately, some mercury was lost during pumping; therefore, environmentally friendly Šantel used a small amount of mercury to limit pollution although he could not be aware of the toxicity of mercury in those early times.

Šantel said that after the prolonged use of his pump the mercury was covered with black sulfur from rubber stoppers that lubricated the glass wall. Mercury friction along the glass wall of the vessel caused electricity and the formation of ozone that was oxidizing mercury much more than the ordinary oxygen.

The capacity of the pump was further increased by an outer tube of a larger internal diameter. Šantel particularly liked to see the mercury flowing through a paper funnel in an upright tube in a darkened room and admired the phosphorescent sparkled brightness.

In the further discussion of 1883, Šantel considered the electric repulsion of liquids described by his "collaborator's discussion", which he did not specify in more detail; maybe that collaborator was Boltzmann himself and Šantel was polite enough not to glorify his own work with his brother-in-law's fame. Similarly, Šantel inadequately quoted the source of his idea of a device for converting the solar heat into mechanical energy. The idea was supposed to be "published in several professional journals in 1874" which could mean Exner and Roentgen's Viennese publication.¹³⁵⁹ Šantel used three glass vacuum tubes, placed at the angles of 60 degrees between them. The motor with rotating blades was propelled by evaporations from the bottom of the heated hot ether, which was driven through the glass tubes. This "engine" could have

¹³⁵⁹ Wilhelm Conrad Röntgen & Franz Serafin Exner, Über eine Anwendung des Eiscalorimeters zur Bestimmung der Intensität der Sonnenstrahlung. *Wien. Ber.* II Volume 69. February 1874.

been running the clock for several months. There was no air in the glass tube with the engine except the vapours of the ether. At the conclusion, Šantel also assessed the efficiency of his device which otherwise resembled the older Crookes' radiometer but, Šantel differently used the steam of vapors of ether.

Šantel was interested in converting solar energy into mechanical work and, above all, in a new way of transmitting sound, known as Bell's phone since 1876. Before Bell the phones were designed by a natural science teacher in southern Germany, Reis, who never succeeded in calling anyone.¹³⁶⁰ Šantel also described the phone's peculiarities by the equations of the membrane magnetization in it. Imagination led him to a parallel telephone transmission of picture and sound¹³⁶¹ in television which inspired Šantel's student Nardin few years later.

Šantel devoted to each study a special chapter. The first section on the vacuum pump on almost ten pages was nearly so long as the other three studies together. As a gifted experimenter and mathematician, he collaborated with his brother-in-law Boltzmann, a professor of general and experimental physics at the University of Graz. Undoubtedly, Šantel's work so far understudied was an important Slovenian contribution to the progress of vacuum technology, which at that time became a driver of technological progress.

8.3 Breakthrough of Vacuum Technology into Industry at the End of the 19th and Early 20th Centuries

The field of technical uses of vacuum in industry began with light bulbs at the end of the 19th century, and over several decades prevailed in all pores of the modern technology. Edison quickly embraced Crookes' vacuum technique and used it in the industry. In 1879, he started to produce carbon-filament lamps at the pressures of the thousandth of a torr. In Europe, similar production was only introduced at the end of the century. Vacuum technology has thus become the basis of

¹³⁶⁰ Beyer, 1999, 110.

¹³⁶¹ Šantel, 1883, 42, 44–47.

large-scale industrial production, and many researchers have used vacuum technology in basic research. Pumps with solid pistons have greatly improved to serve better the bulb industry. In 1892 the Londoner diving engineer Henry Albert Fleuss (1851 Marlborough in Wiltshire-1932) invented and in the following year got a German patent for a piston pump sealed with oil. It had mechanical displacement dampers. In Guericke's honor, he named his invention "Geryke's pump" and reached $2.6 \cdot 10^{-4}$ mbar. Despite the worse vacuum, the pump had an advantage over older pumps with a liquid piston, as it was able to propel the engine. It delivers an almost constant suction because it uses a cylinder divided in halves: as one half of the cylinder is filled with air, the other half is evacuating air to the atmosphere by a stroke of the pump. The next stroke reverses that action to produce the constant flow. It was used in the light bulb industry until 7. 9. 1955. As an assistant at the University of Freiburg, Gaede patented circular-acting motorized pumps and a mercury piston. With it, the experts reached 10^{-6} mbar; so, the device became extremely useful in the lighting and cathode-ray industry. Gaede replaced the glass casing of older pumps with metallic casings, and he used the rotary drum made from porcelain.

One year before Leybold's death in 1906, his firm began working with Wolfgang Gaede, who developed vacuum pumps for Leybold;¹³⁶² mostly a molecular pump in 1911/12. Gaede demonstrated yet another novelty to the 77th meeting of German naturalists and physicians in Merano in Lower (South) Tyrol. He received a great attention and

numerous offers. All listened and were interested in buying options. Gaede's report from the meeting was later read by his eleven-year-old chemist Alfred Schmid, son of the owner of machine-shop of E. Leybold's heirs. Schmid was well over a decade older than Gaede, and he immediately smelled a profitable bargain. In that time that the company was in trouble because the competitors were licensed to produce "Guericke's (Geryke's) Pumps". That is why Schmidt went to Freiburg with his first morning train in February 1906. He signed a contract with Gaede on 23 April 1906 and began one of the most fruitful collaborations between a scientist and industry which lasted for

Max Paul Wolfgang Gaede was the son of the Prussian artillery officer and therefore often moved through different German cities. In Freiburg, he first studied medicine and then graduated in physics from Franz Himstedt's class in 1901. Himstedt excelled with his experiments in electrodynamics. On February 26, 1904, as Himstedt's assistant, Gaede described his own experiments in a vacuum for the first time. After the war, in 1919, he received a regular full professorship in nearby Karlsruhe. His inventions were indispensable in physics laboratories. That is why Lenard proposed Gaede for the Nobel Prize in 1926, but the Swedes were not convinced. Although the Nobel Prize-winning Lenard was a high-ranking Nazi man, the Nazi authorities nevertheless deprived Gaede of his professorship in a very humiliating way on 30 June 1934, two months after Göring ceded the leadership of Gestapo to Himmler and his associate Reinhard Heydrich. Gaede was a victim of barbarous era witch hunt after two of his jealous employees denounced to the Gestapo that Gaede called the National Socialists "childish". Gaede had to retire, although all he proved accusations to be false. To enable Gaede to continue his work, Leybold set up an interim laboratory and store at Gaede's home. In 1940, despite their kind attention, however, Gaede, together with his laboratory, moved to Munich, where he died shortly after the end of the war.



Wolfgang Gaede (* 1878; † 1945)

¹³⁶² Leybold, 1994, 8.

thirty-eight years. The following year, Leybold equipped Gaede with a hardware store, which in 1912 became part of the university. In the same year, Gaede invented a "molecular" pump. Gaede proved to be an extraordinary acquisition despite of false denunciations of two Gaede's employees in 1933/34.

Leybold sold its first sixty samples of the new type of pumps in the same year 1912, and they sold a total of 300 by 1923, when the severe economic crisis broke out worldwide. The "Molecular" pumps were developed to reach 10^{-7} mbar in the next three decades.

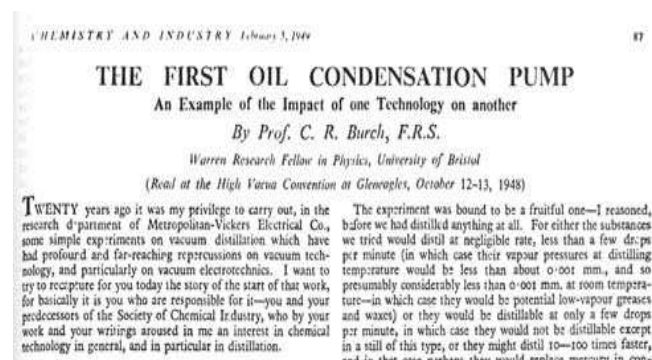

Figure 8-7: Front Cover C. R. Burch's *Discussions* issued two decades after his *Oil, Greases, and High Vacua*, published in *Nature* in 1928.¹³⁶³ He left Metropolitan-Vickers for academic research in G.P. Thomson's Imperial College in London after the tragic death of his elder brother Francis Parry Burch (1899-1933), another brilliant son of the optician George James Burch FRS (1852-1914).

In 1913 Gaede investigated the opposite flow of mercury vapor and air in a vacuum system pumped with a rotary pump. Similar research has been done by others; so, Russian professor Stanislaw Antonowitsch Borovik (Воровик Станислав Антонович Боровик, 1882-1958) in Leningrad and Gaede in 1915 and Langmuir later independently invented a diffusion pump with mercury vapor. This were the first vacuum pump without moving parts, which Langmuir patented in 1919 and 1921, and Gaede in 1923. Both used a separate stand-alone position in their leading industrial company as a basis for their exceptional discoveries (Figure 8-7). Borovik worked in the first Russian Roentgen-tubes lab of N.A.

¹³⁶³ Redhead, 1994, 185.

Fedoritzki. From there Borovik reported his invention on Section of Physics of Russian Physics-Chemistry Society on 13th September 1916. He became an expert in spectroscopy, but he was even surpassed by his wife the spectroscopist Татьяна Фёдоровна Боровик-Романова (1896 Tomsk—1981) of Russian imperial family Romanow and their son low temperature specialist academician Wiktor-Andrei Stanislawowitsch Borowik-Romanow (Виктор-Андрей Станиславович Боровик-Романов, 1920 Leningrad-1997).

For eleven years, Cecil Reginald Burch FRS (1901 Leeds-1983) worked for Metropolitan-Vickers Electrical Company of former George Westinghouse's extension in English Manchester. The heavy electrical engineering proved to be just one of the platforms of Metropolitan-Vickers as they hosted such eminent inventors as Burch and Gabor. In 1928, Burch invented a diffusion pump with oil. Diffusion pumps with the pressures available down to 10^{-8} mbar were commonly used for high vacuum, especially in the American electronics industry between 1920 and 1940. They were displaced from the market by the pumps designed for ionic sputtering in 1958, on centennial of Geissler-Plücker's discovery. Plücker has already noticed the pressure drop in the vacuum tube due to discharge a century before its use in the pump: "Some gases react ... with platinum cathode and the resulting compounds are deposited on the walls. so, we approach ... the absolute vacuum." In 1902, Richard Smith Willows (* 1875) announced chemical compounds with glass in the walls of cathode ray tube; but the Norwegian aurora borealis expert Lars Vegard (1880–1963 Oslo) rejected his assumptions.¹³⁶⁴

8.4 Conclusion

Of course, nobody can avoid the limitations imposed by nature itself. Thus, in 1977 C. Benvenuti reached 10^{-14} mbar in CERN, which for over three decades remains the lowest man-made vacuum available at room temperature. The modern failure to achieve an ever-better vacuum is like the similar stagnation between 1920 and 1950.¹³⁶⁵ Who will overcome it?

¹³⁶⁴ Lafferty, 1998, 176–178, 317, 625; Plücker, 1858, 84.

¹³⁶⁵ Redhead, 1999, 146.

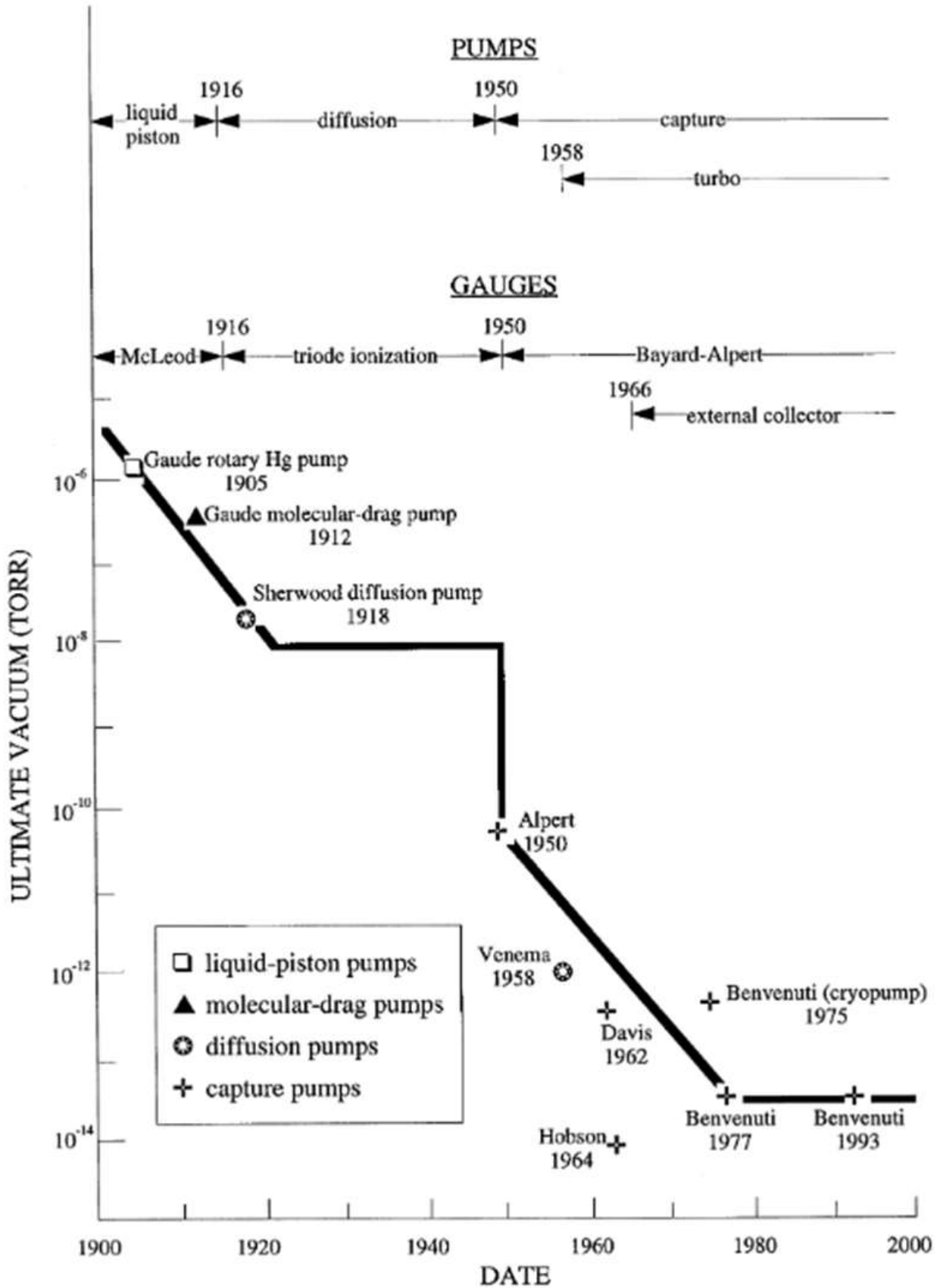

Figure 8-8: Graph of the best achieved vacuum between 1900 and 2000¹³⁶⁶ with added achievements in Slovenia with the use of vacuum technology.

¹³⁶⁶ Redhead, 1999, 144.

9 Plasma Waves or Corpuscles for New Aggregate State?

9.1 Beginnings of the Research of "Cathode Rays" at the End of the 19th Century

Cathode rays were the old name for the electron rays. In the second half of the 19th century, the experiments in the emptied tubes raised the question of the nature of the cathode rays. The second generation of researchers have greatly revived the exploration of cathode rays in the 1890s. The English mostly wrote about particles, while the Germans were the fans of waves.¹³⁶⁷ The nationally colored, even personal contradictions between researchers, became so sharp that the Germans even declared Crookes a charlatan.¹³⁶⁸

9.2 Supporters of the Wave Model

In German language light of lighting is Licht while the light as lightweight is leicht. For French, lightweight is léger while the light of lighting is lumière. In other languages including Slavic ones there is even sharper difference between both with light of lighting more resembling something not at all lightweight but rather saint or even cosmic as the word svet means in Slovenian language. In Latin language lux and lucis as light of lighting is also far from levitas as leightweight, and similar goes for the Italian luce. Therefore, the English language speaking folks including the Newtonians were convinced that the sources of light must output something lightweight, most probably the miniature particles, as soon as they abandoned their Latin speaking after Henrik VIII and his virgin daughter Elisabeth embraced the Protestant English language bible. The Germans doubted it because of their additional letter "e" in leicht which made their pronunciation basically different. The Catholic who preferred the Latin liturgy had even more doubts in lightweight sunshine even if waves of light could be imagined as something even lighter than particles. The quarrels between

the proponents of waves and particles were therefore mainly the quarrels on semantic until the English language became the lingua franca of us all to pave the ways for the modern wave-particle quantum dualism.

Helmholtz's circle of supporters of waveforms of light, with the most prominent representative Hertz, found that the properties of "cathode rays" resembled the properties of light. For both they gave several striking similarities:

- 1) they are eliminated from heated and some cold surfaces
- 2) they are expanding linearly
- 3) they can cause fluorescence of glass
- 4) the magnetic field does not curve their paths much (soon proved to be false for cathode rays)
- 5) they spread in all directions with respect to the orientation of the illuminating surface (soon proved invalid for cathode rays)
- 6) the properties of light or cathode rays) generally do not depend on the characteristics of the heated lamps (or cathodes)
- 7) they transmit energy
- 8) they carry the momentum

The deflection of the cathode rays in the magnetic field was explained by the deformation of the "ether" in it. Spreading exclusively in the rectangular direction relative to the surface of the source was attributed to the electrical characteristics of the formation of "cathode rays".

9.3 Corpuscular Model and Crookes

For the proponents of the corpuscular model of cathode rays the main problem was the puzzle of their rectilinear propagation. In 1891 and 1892, Hertz pierced a thin layer of gold, silver, aluminium and various castings with cathode rays, which no known particles could up to date. Of course, the English partisans also had their own trumps, which Crookes was intending to pursue.

¹³⁶⁷ Carazza, Kragh, 1990, 4.

¹³⁶⁸ Frisch, 1972, 54–55.

Crookes was a physicist under Faraday's influence. Crookes' mathematical knowledge was inadequate, and therefore the leading British theoretical physicist Stokes was has often helped him. For Crookes, the interplanetary space seemed a giant emptied tube with the Sun instead of the cathode and the Earth's atmosphere as the glass surface of the cathode ray tube. If Newtonian light beam had some properties of the wave in addition to the particle properties, Crookes merged both opposing descriptions in a way that reminds us of modern quantum mechanics. According to Crookes, light consisted from particles should be in a vacuum, while light consisted from waves is in other media. Crookes did not yet know Hittorf's surveys carried out in Bonn in 1869.¹³⁶⁹ In 1876 and on 22 August 1879, at the Congress of the British Society in Sheffield, Crookes declared radiation for the fourth physical state of the matter:

"In studying this Fourth state of Matter we seem at length to have within our grasp and obedient to our control little indivisible particles which with good warrant are supposed to constitute the physical basis of the universe. We have seen that in some of its properties Radiant Matter is a material as this table, whilst in other properties it almost assumes the character of Radiant Energy. We have actually touched the border land where Matter and Force seems to merge into one another, the shadowy realm between Known and Unknown which for me has always had peculiar temptations. I venture to think that the greatest scientific problems of the future will find their solution in this Border Land, and even beyond; here, it seems to me, lie Ultimate Realities, subtle, far-reaching, wonderful."

In 1880, the Scotsman Tait and after him Goldstein announced that the wavelength of Crookes's supposed molecules was changed at high velocities of cathode rays due to the Doppler effect. Measurements did not confirm those promising forecasts.¹³⁷⁰ In the 20th century the astronomers had observed a similar phenomenon on celestial bodies as a redshift.

Even Stokes did not support the idea of corpuscular properties of light, since he was raised in a generation that repudiated a similar concept in the Newtonian version. But Stokes certainly

directed his thirteen years younger Crookes to the idea of the fourth aggregate state of matter. Particularly fortunate was Crookes' presumption that in this state "matter passes into force" or energy, which specifically fueled German criticism.¹³⁷¹ Germans just abandoned their own idealistic philosophy. Therefore, they refused Crookes' spiritualism. But their mutiny was in vain, resembling futile attempts of Leibnitz and Bernoulli to ignore alchemistic background of Newtonians two centuries earlier. Crookes' duality remerged into Bohr's quantum mechanics, while Crookes' fourth state transformed into Langmuir's plasma.

9.4 Waves and Particles at the Same Time

The results of the experiments conducted in Germany did not support British corpuscular theories. The leading German theoretical physicist Helmholtz predicted longitudinal waves in the "ether". For some time, it seemed that they were found in cathode rays. The seeking for longitudinal waves in the "ether" has initially directed Hertz experiments between 1887 and 1889, as he measured the electromagnetic waves which also many searched for several generations. In November and December 1895, Röntgen investigated the rays produced by the interaction of cathode rays with the glass wall of the vacuum tube. At first, he mistakenly considered them for the long sought longitudinal component of the electromagnetic wave in the "ether".¹³⁷²

Crookes model of rays, which in some experiments have properties of waves, and in others, the properties of particles, was published in the late 19th century. Through the great physics door, it entered only in quantum mechanics with the material waves of Louis de Broglie after 1923. To Maxwell's contemporaries that duality would certainly seem unusual, and even more so to Grove and other older researchers. In 1842, Grove argued in favor of the success of Fresnel optics in a lecture before the Royal Institution (RI). Unlike most of his contemporaries, the "ethereal fluid" seemed to

¹³⁶⁹ Crookes, 1905; Čermelj, 1980, 70; Crookes, 1879, 29-30.

¹³⁷⁰ Frisch, 1972, 55; Laue, 1969, 310-311; Anderson, 1968, 36, 39, 48.

¹³⁷¹ Staroselskaja-Nikitina, 1967 16-17; Wilson, 1987, 191, 198-199, 201; Puluji, 1889, 235.

¹³⁷² Anderson, 1968, 69-71; Frisch, 1972, 55; Wheaton, 1983, 15-18.

him superfluous; the ordinary substance is enough to transmit vibrations in the space.¹³⁷³

Hertz (1888), J. J. Thomson (1897), Einstein (1905), and others preferred to emphasize the connection of their discoveries with Maxwell's theory (1873) than to expose their differences in the description of the structure of the "ether" and electricity.¹³⁷⁴ The achievements of the Brits encouraged the Germans who returned to Brits even broader challenges with the ideas of Planck (1900) and Einstein's (1905) particle theory of quanta and photons as the Ljubljana physician Franc Derganc (1877 Semič-1939 Ljubljana) told his compatriots: "In 1900, Planck, a professor of theoretical physics in Berlin, examined the mathematical conditions in thermal radiations and found that the effect did not happen evenly, but in jumps, in shovels."¹³⁷⁵ So, the Slovenes soon read about the compromised conclusion of the dispute between the defenders of the waves and particles that is still in force today in duality of quantum mechanics.

¹³⁷³ Brush, 1976, 320, 326.

¹³⁷⁴ Cazenobe, 1984, 972–986.

¹³⁷⁵ Derganc, 1917, 103.

10 Advanced Metrology

10.1 Development of Manometers

The better vacuum pumps needed more sophisticated manometers to measure their own void achievements. With McLeod's pressure gauge, pressure was determined indirectly from higher pressure measurements. Later researchers intensified the idea of indirect measurement. It turned out that gas pressure can be determined indirectly from completely different gas properties: thermal conductivity, viscosity, radiometric phenomenon and discharges. According to Maxwell's kinetic theory, the first two phenomena are independent of the pressure for average free pathways of molecules much smaller than the vessel; this does not apply to a vacuum.¹³⁷⁶ Viscosity, radiometric and electrical phenomena have already been used by Crookes in the middle of summer 1876 in parallel with McLeod's¹³⁷⁷ manometric pressure gauge for indirect pressure measurement. Nevertheless, useful manometers were developed only two decades later.

10.2 McLeod's Compression Gauge

The enhancement of pump and manometer's performance has undergone numerous improvements of flaps, connectors and traps in vacuum systems over the centuries. The professor of Physics and Chemistry in Paris, Regnault, measured pressures lower than the atmospheric with Hooke's wheel barometer, specially adapted for weather changes. The device was named "differential barometer".¹³⁷⁸

Herbert G. McLeod was the oldest son of a London brewer; Joule was a brewer's son too, which made some strange connections between a good beer and good experiments in England. Herbert G. McLeod began his study of chemistry in 1855 under supervision of the professor George Frederick Ansell (1826-1880) at Panopticon in Leicester Square of West End London. In 1860, McLeod became Hofmann's assistant for chemistry at the newly established

Royal College of Chemistry and at the Royal School of Mines in London. As assistant, he accompanied Hofmann, who returned from England to Bonn in 1863/64. In Bonn, they collaborated with Geissler and Plücker, the most important researcher of cathode-ray tubes at that time. After Hofmann's appointment as professor of chemistry in Berlin, McLeod returned to England as an assistant at the Royal College of Chemistry. He was already a famous researcher of discharges in a vacuum. In 1868 he was elected a member of the Chemical Society, and in 1871 he became professor of chemistry and physics at the Royal Indian Engineering College in Cooper's Hill and ten years later FRS. From 1868 he was also an advisor to the Oxford graduate, Marquis Salisbury, in his experiments at his home "Hatfield House", which he then inherited together with the title of Marquis. In 1869, Salisbury was chosen for the FRS, and in the same winter he illuminated the south wing of the house with Arclight. Then McLeod published a paper about a vacuum pump that Sprengel invented in London four years earlier. Salisbury was Secretary for India in 1866 and 1874. In 1873, Salisbury used McLeod's help to publish his research of discharges near mercury thermometers in *Phil. Mag.* Later in his eulogy upon Salisbury's death, McLeod summed up the report of Kayser, a professor of physics and director of the Physics Institute at the University of Bonn in Salisbury. Kayser praised Salisbury's discussion as the first proof that a low-temperature gas can radiate a clear spectrum of visible light. In 1878 and 1879 McLeod studied the dynamo and electric bulb and helped the then Foreign Minister Salisbury to illuminate the interior of his house with energy from his own hydroelectric power plant. Their collaboration, as an example of the highest position of science in the English society at that time, only ended between 1885 and 1902, when Salisbury served as the Prime Minister with some brief intervals out of office. Later, McLeod also investigated the effect of light on a type of rubber called ebonite. In 1915, due to health problems, he stopped active work. He spent the last five years in Richmond, Surrey County, where he died in 1923.

In the middle of the 19th century, mercury pressure gauges were only able to measure the pressure

¹³⁷⁶ Penning, 1937, 202–203.

¹³⁷⁷ DeKosky, 1984, 97–98.

¹³⁷⁸ Ganot, 1886, 159.

little below 1 mbar. Improved pumps required a better meter which was invented by McLeod¹³⁷⁹.

On 13. 6. 1874, McLeod pressed gas under mercury to the measurable higher pressure, from which, according to Boyle's law, the initial pressure was calculated with accuracy of a millionth part of mbar (Figure 10-1). The meter was connected to Sprengel's pump, a emptied receiver and a siphon barometer, which had a tube about 5 mm wide. The container of the measuring



Figure 10-1: The McLeod's manometer.¹³⁸⁰

device with a volume of about 48 cm³ was narrowed at the top in a tube with a scale. Below it, McLeod connected it with a tube about 800 mm long connected to a mercury collector. The drainage from the reservoir was controlled by a tap and McLeod observed the movement of the mercury surface through the telescope.

In 1878 in the Parisian *Annales de Chemie et de Physique* William de la Rue and Hugo W. Muller, published a discussion about the combination of the Geissler pump with Sprengel's pump and about the McLeod Vacuum-Meter. Edison read a

¹³⁷⁹ Ganot, 1886, 159.

¹³⁸⁰ Madey, 1984, 102.

translation of their discussion, and at the end of 1879, McLeod's manometer was purchased for his laboratory at Menlo Park.¹³⁸¹

Gaede investigated systematic errors in the measurements with a McLeod manometer. McLeod manometer with a rotary axis has been developed; it is still used today¹³⁸² for measurements from 1 to 10⁻⁶ mbar.

10.3 Viscosity Pressure Gauges

The Australian physicist Sutherland tried to restore the research of phenomena in the radiometer in 1896 as Boltzmann's fan and later predecessor or Einstein's statistic explanation of Brownian motions. We call with Sutherland's name an equation describing the change in viscosity with temperature. The following year he described the determination of the pressure in a vacuum by measuring the viscosity of the gas. His idea was used by J. L. Hogg at Jefferson Physical

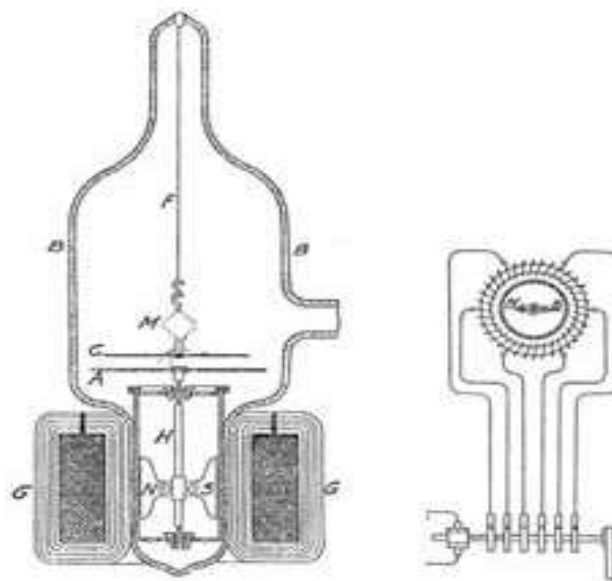

Figure 10-2: Dushman's rotary cylinder meter.¹³⁸³

Laboratory, Harvard University. Cambridge, Massachusetts in 1906, and seven years later by Langmuir, who also published the law of thermionic emissions. Langmuir used the fiber made of quartz, which fluctuated in gas. The

¹³⁸¹ Friedel, Israel, Finn, 1986, 61–62.

¹³⁸² Günter Reich, Wolfgang Gaede, In Redhead (ed.), Vacuum Science and Technology, Pioneers of the 20th Century, History of vacuum science and technology, Vol. 2, AIP Press, 1994, 53; Lafferty, 1998, 381.

¹³⁸³ Redhead, 1998, 1399.

pressure in the gas was measured by the contraction of the amplitude of the oscillation. In 1915, Dushman used Langmuir's description in a rotary cylinder for measurements of down to 10^{-7} mbar (Figure 10-2).¹³⁸⁴ In 1916, Langmuir described his manometer version and high-vacuum pump.

Saul Dushman was born in a Jewish family in Rostov in Russia. They moved to Canada in 1892. He studied at Toronto, where he also received a doctorate in physical chemistry in 1912. He then went to General Electric (GE) in Schenectady, where he always worked closely with Langmuir. In 1917 he became a citizen of the United States. Between 1923 and 1925, he led research in the first General Electric lamp factory "Edison Lamp Works" in Harrison, New Jersey. From 1928 until his retirement in 1948, he was assistant director of the research laboratory GE. In 1949 he published a book on the scientific foundations of vacuum technique, which became indispensable in its field and was reprinted in an updated form in 1962.



Saul Dushman (* 1883; † 1954)¹³⁸⁵

After his participations on Manhattan project, Jesse Wakefield Beams (1898 Belle Plaine in Kansas-1977) from the University of Virginia increased interest in viscosity manometers in the 1950s. It has been shown that the pressure in the vacuum can be determined by measuring the frequency of the rotating steel ball in the magnetic field. The frequency was about 1 MHz. Thus, in principle, it can measure down to 10^{-9} mbar. Later, the device

¹³⁸⁴ Brush, Everitt, 1969, 124.

¹³⁸⁵ Redhead, 1994, 32.

was perfected by Johan K. Fremery in Bonn in 1985/86, but today it is used for measurements between 10^{-2} and 10^{-7} mbar.¹³⁸⁶ However, viscosity manometers were not widely used before the improvements of rabbi Ernst Steckelmacher's (1881 Mannheim-1943 Majdanek) son Walter Steckelmacher (1922 Mannheim-2006 Crawley in West Sussex) at the University of Sussex in Brighton in 1973.

10.4 Application of a Radiometric Measurement of Pressure

In 1907, Dewar reportedly cooled his radiometer to the temperature of the liquid air, hydrogen and helium. He thought that radiometer could measure the pressure more accurately than McLeod's barometer. He recommended radiometer for the detection of gaseous products of radioactive bodies.¹³⁸⁷

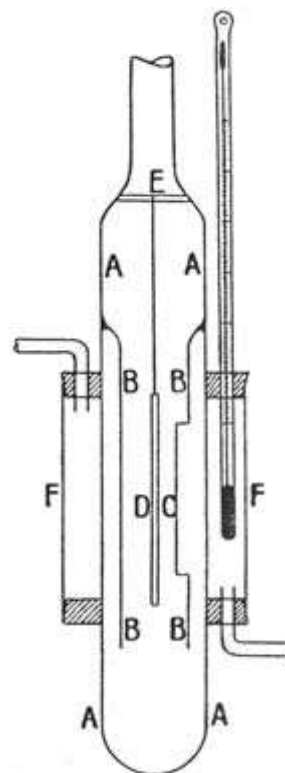

Figure 10-3 : One of Knudsen's pressure gauges on the radiometric phenomenon of 1910.¹³⁸⁸

In 1910, at the University of Copenhagen, Knudsen composed a pressure gauge based on a radiometric phenomenon, which was not yet fully

¹³⁸⁶ Redhead, 1984, 32.

¹³⁸⁷ Dewar, 1927, 983-987.

¹³⁸⁸ Knudsen, 1910, 828.

understood in his time, although he roughly knew the dependence of the radiometer spinning on the pressure (Figure 10-3). Knudsen measured the total pressure in the room, not the partial pressures like McLeod's manometer, which, for example, could not measure the mercury vapor pressure. That is why Knudsen called his device an "absolute gauge" relating to the "absolute electrometer" described by Lord Kelvin earlier in 1855.

Knudsen measured the torque due to the transfer of the momentum from the heated molecules of gas on one side to colder molecules on the other side of the plates. In parallel to the heated metal plate, he placed a flexible metal plate as a handle of a torsion scales for measuring the repulsive force. The slabs were very thin, $2.5 \cdot 10^{-4}$ cm thick and 0.01 cm thick. Therefore, he observed the reflection of movement of the plate on a small mirror through the telescope.

The Polish knight **Marian von Smolan Smoluchowski** was born near Vienna where he studied at Stefan's class and promoted in 1894. He spent some time in the labs of Gabriel Lippmann in Paris, Lord Kelvin in Glasgow and Warburg in Berlin. He taught at Habsburgian universities. Between 1898 and 1913 he was a professor at the University of Lviv, then in Krakow, ultimately as a rector. In 1898, the mean free path in the kinetic theory of molecules explained the leakage of temperature (and velocity) between the surface of the plate and the gas. The occurrences were discovered by Kundt and Warburg in their measurement of diluted gas, placed between the plate of various temperatures at the University of Strasbourg in 1875. In 1905 and 1906, Smoluchowski described the Brownian movement, simultaneously and independently of Einstein in Bern and Sutherland. Smoluchowski used Boltzmann method. In 1907 and 1908 Smoluchowski explained opalescence with statistical theory. He was one of the most important advocates of Boltzmann's description of the second law of thermodynamics. He died in Krakow during the First World War, killed by a dysentery epidemic.

Knudsen's experiments, the distance between the plates was much smaller than the average free path of the molecules. During gas exhaustion, the

reflecting force between the plates increases inversely proportional to the pressure up to a

Martin Knudsen was born on the island of Fyn. He studied at the University of Copenhagen and was a professor there between 1912 and 1941. Among his important contributions to vacuum techniques was his absolute pressure gauge reported on the 1st Solvay Congress. In 1909 and 1915 he supplemented Hertz-Knudsen's fundamental equation for the rate of evaporation. He published the first indirect proof of Maxwell-Boltzmann's distribution of molecules in terms of velocity. During the study of gas flow through narrow tubes, he discovered the law of diffusion of molecules and advanced his theory of radiometer.



Martin Knudsen (* 1871; † 1949)

ertain maximum, and then decreases proportionally to the pressure. Crookes and others noted similar findings in 1875 and 1876. However, Knudsen was the first to derive a simple equation for the proportionality of the repulsive force and pressure at the known temperature ratios. Thus, the size of the pressure can be determined from the measurement of the reflecting force between the plates. He made several manometers. The first one had a copper cylinder of 1.63 cm radius, the most convenient being a tube made of glass of thickness 0.41 cm, 1.4 cm wide and 2.95 cm high. He measured the temperature with a mercury thermometer. He pumped with Gaede's mercury pump to a pressure of $4 \cdot 10^{-3}$ or $5 \cdot 10^{-3}$ mbar of

hydrogen, oxygen or CO₂ atmosphere, which he also doublechecked with McLeod's manometer. The Pole from the University of Lviv Smoluchowski immediately published the theory of diluted gas flow and described the operation of the Knudsen gauge with Maxwell's kinetic theory in In November 1910¹³⁸⁹. He praised Knudsen's measurements, but criticized his theory which claimed that, in a narrow band above the edge, the higher pressure due to higher molecular velocities prevails over the pressure reduction due to a smaller free path at the barrier, thus increasing the overall pressure. The dispute continued the controversy of Maxwell and Meyer from the University of Breslau (today's Wrocław) against Irish researchers Stoney from Galway and his nephew, George Francis FitzGerald of Dublin, who claimed that the reflection between the radiometer's flaps was a superficial phenomenon. Maxwell and Knudsen after him correctly wrote that "the pressure due to the inequality of temperatures happens only close to the edges of the

*12. Bemerkung zur Theorie
des absoluten Manometers von Knudsen;
von M. v. Smoluchowski.*

Seit der Zeit, da die voranstehende Arbeit abgefaßt wurde, hat Knudsen eine neue Abhandlung: „Ein absolutes Manometer“¹⁾ veröffentlicht, in welcher derselbe das bemerkenswerte Resultat begründet, daß ein stark verdünntes Gas auf eine Platte, welche Wänden von verschiedener Temperatur gegenübersteht, einen einseitigen Druck ausüben muß. Die von ihm p. 816—823 abgeleitete Formel läßt sich nun leicht auf Grund der vorhin aus Maxwells Annahmen (über Reflexion, Absorption und Emission der Moleküle an der Gefäßwand) gefolgerten Analogie der Molekularbewegung stark verdünnter Gase mit der Wärmestrahlung innerhalb eines überall gleich temperierten Gefäßes erweisen.

Figure 10-4: Smoluchowski's criticism of Knudsen's absolute manometer.¹³⁹⁰

plates, where the second derivative of temperature by volume is not zero".¹³⁹¹

Smoluchowski denied absolute validity of results of Knudsen's pressure gauge because the measurement of small temperature differences between the plates should depend on the material of the plate (Figure 10-4). However, Knudsen's report on the "absolute radiometer" with force

¹³⁸⁹ Kundt, Warburg, 1875, 337–366, 177–211.

¹³⁹⁰ Ann. Phys. 34 (1911) 182.

¹³⁹¹ Maxwell, 1879, 332; Knudsen, 1910, 810–811.

proportional to the pressure was adopted at the 1st Solvay Congress between in Brussels 30 October and 3 November 1911. Only Einstein from Prague and Hasenöhrl from Vienna participated there as the professors from Habsburg universities while Smoluchowski was not invited. In 1934 Gaede improved Knudsen's manometer and preferred it as his best among all the meters (Figure 10-5). Today, it is used only in special noted circumstances.¹³⁹²



Figure 10-5: Gaede's Mol-vakuum-meter.¹³⁹³

Knudsen and Smoluchowski continued the dispute over the absolute validity of the Knudsen's gauge measurements. In 1911, during their fruitful debates, they also checked the operation of the pressure gauge on the heat conductivity, which is now known as Pirani's gauge. Knudsen and Smoluchowski were engaged in friendly exchanges of opposite views, much unlike Smoluchowski's predecessors at the Krakow university, Olszewski and poor burned Wroblewski.

Knudsen and Smoluchowski did not mention Stefan's measurements with diathermometer, but above all relied in measurements of the heat conductivity of Kundt and Warburg from 1875. They confirmed that down to 1 mbar thermal conductivity does not depend on the pressure in

¹³⁹² Redhead, 1984, 32.

¹³⁹³ Reich, 1994, 53.

Marcello Pirani was a Berliner of Italian descent. After studying at the Technical University of Berlin, he joined the German Physical Society, led by Max Planck and others. After his doctorate in October 1904, Pirani worked at the Siemens & Halske Lighting Factory in Berlin. From 1918 he was a professor at the Technical University of Berlin and after the founding of the conglomerate of German lighting firm bulb producers called Osram in 1919, he became the head of its research laboratories. The merged Osram followed the similar merged Telefunken of 1903 to provide better opportunities for German electronics. Pirani began to use the discharges in diluted gases for lighting instead of bulbs around 1930. In 1930, Pirani already produced lamps with 70% efficiency, and the following year Pirani's bosses started selling lamps with sodium steam and then the fluorescent lamps. In 1936, because of opposition to the Nazi authorities, Pirani went to England to join the General Electric Co. in Wembley, where his manometer was explored already in 1923. In 1953 he returned to Munich and two years later he returned to Osram in Berlin.



Marcello Pirani (* 1880; † 1968).¹³⁹⁴

accordance with Maxwell's opinions. Knudsen has studied even lower pressures in which the average free path of the gas molecules greatly exceeds the size of the vessel. Kundt and Warburg measured gas between the plates of different temperatures and detected a temperature jump between the surface of the plate and the gas. That phenomenon

¹³⁹⁴ Redhead, 1994, 83.

could not be explained without the Smoluchowski's kinetic theory of molecules developed in 1898.

Pirani's invention ceased the annoying discomfort in the handling of McLeod's meters at Siemens & Halske in Berlin. There, Pirani utilized some 50 McLeods tools for his research of tantalum lamps. Each used about 2 kg of mercury; so, often there was a breakdown and toxic mercury was spilled everywhere on the floor of the laboratory: "I set out to develop a simple cheap vacuum gauge that could replace McLeod's. The project was not intended solely for the technique of rapidly detecting small pressure changes in a high vacuum but had a great health significance. It is known that it is becoming increasingly difficult to remove harmful mercury from the workshops." There was still no official recognition of mercury risks despite of old Hacquet's research, but the quicksilver pollution didn't please anyone anyway.

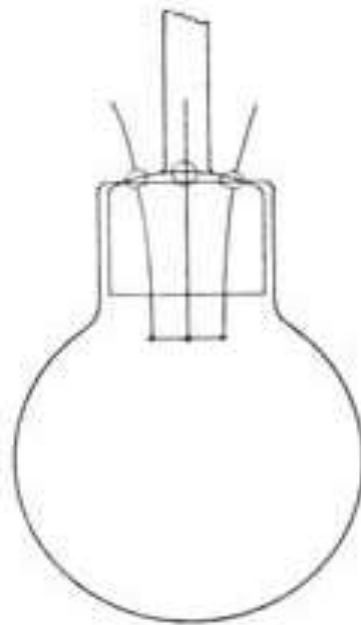

Figure 10-6: Voegé's device for measurements of alternating current between 0.001 and 0.1 A, which determined the pressure through the conductivity of the diluted gases.¹³⁹⁵

In June 1906, the pedantic Pirani as the best merge of Italian-German genes developed a device for indirect pressure determination in emptied receiver by measuring the thermal conductivity of the gas. The change in the electrical resistance of the heated conductor in the vacuum measured the heat

¹³⁹⁵ Phys. Z. 7 (1906) 500.

lost by the gas throughput. so, he got a measure of pressure. A few months before Pirani, Willy (Willi) Voege in Hamburg and later Rohn developed similar pressure gauges using a thermocouple or thermistor whose output voltage is dependent on the pressure. Many newly developed devices replaced McLeod's manometer (Figure 10-6).¹³⁹⁶ In the 1930s, processes were developed for calculating the pressure from the measured thermal conductivity of the gas with a bimetallic thermometer or with evaporation rate in the Dewar's flask.¹³⁹⁷

10.5 Mechanical Pressure Gauge (Manometer)

In 1929, the Americans from the university of California at Berkeley Axel Ragnar Olsen (1889 Halsingborg Sweden-1954) and his Ph.D. student Lester Larsen Hirst (* 1903) who later worked for Bureau of Mines described the pressure gauge on the capacitance to measure the pressures between 10 mbar and 10^{-4} mbar; so, they crowned the development of indirect pressure gauges. A similar mechanical manometer on the Bourdon's tube was already discussed by the professor engineer in Gdansk Hans Lorenz (* 1865 Wilsdruff west of Dresden in Saxony; † 1940 Sistrans by Innsbruck in Tirol) in 1917. Lorenz bended the pipe to measure the pressures from 1 bar to 30 mbar. Soon, mechanical pressure manometers measured a pressure down to 0.1 mbar.¹³⁹⁸

10.6 Hot Cathode Ionization Meters

The lower pressure gauges were lagging somewhat behind the achievements of the pumps before the First World War. Useful manometers were only McLeod, Knudsen and Langmuir-Dushman's with a rotating cylinder.¹³⁹⁹ The last two were complicated, slow, and they did not measure

¹³⁹⁶ Pirani, 1906, 686; Redhead, 1984, 32; Lafferty, 1998, 404.

¹³⁹⁷ Penning, 1937, 202–203.

¹³⁹⁸ Redhead, 1984, 33; Lafferty, 1998, 383; Mattox, 2000, 2 (i.e. 518); A. R. Olson and L. L. Hirst, A new differential pressure gage J. Am. Chem. Soc. 51 (8), 2378–2379 (1929); Hans Lorenz (not the Dutchman Hendrik Antoon Lorentz (1853-1928)), "Theorie der Röhrenfeder manometer," Phys. Zeits. 1917, 18: 117.

¹³⁹⁹ Redhead, 1999, 143.

enough low pressures. That's why they were looking for better solutions. Only the invention of the ionization gauge on the hot cathode has allowed the development of modern vacuum manometers. In 1909 at the Physics institute of University of Berlin Hahn and L. Meitner's collaborator Otto von Baeyer continued with Lenard's study of slow electrons from the Wehnelt's oxide cathode segments and showed that the triode can be used as a pressure gauge in a vacuum. Von Baeyer's research was rediscovered only by Redhead in 1984, so that for a long time the inventor of the ionization gauge seemed to be Oliver Ellsworth Buckley (1887-1959) who measured the vacuum in the Research laboratory of American telephone and telegraph company (AT & T Corp.) and of Western electric company with the frequency of ionization in hot triode in 1916 and published his achievement in highly popular Scientific American next year. Buckley sealed three platinum electrodes in a 6 cm long glass tube used for cathode, anode and a positive ion collector. In vacuum, the electrons fly from the cathode to the anode, so that the current does not flow to the collector. In the gas, electron collisions produce positive ions. They fly towards the reservoir, which is negative in relation to the cathode. Buckley measured a pressure-dependent ratio between the collector and the anode current in the range between 10^{-2} mbar and $5 \cdot 10^{-4}$ mbar. The results were confirmed by parallel measurements with McLeod and Knudsen manometers. A similar ratio was obtained in air, hydrogen and mercury. Since there were no movable parts in the triode, the vibration did not disturb the measurement. The ionization gauge was much cheaper, faster and simpler than its predecessors, as the pressure was determined by the galvanometer measurement. It was possible to measure the pressure of metal vapors, where older meters failed and gave up. Many people liked to study the miniature versions of the ionization gauge developed in the age of space flights.

Buckley's gauge was used until the middle of the 20th century for measurements down to 10^{-8} mbar and less. Among others, Paul A. Anderson in Washington achieved excellent results. He measured the contact voltage between barium and tungsten by Kelvin's method in 1935.¹⁴⁰⁰ At lower pressures, the measurement was interrupted by soft

¹⁴⁰⁰ Baeyer, 1909 169; Buckley, 1916, 683–685; Redhead, 1984, 33; Lafferty, 1998, 415.

X-rays produced by the bombarding of anode with electrons which generated a constant pressure of about 10^{-8} mbar. The effect was known to manufacturers of cathode ray tubes but not to their related vacuum technology researchers before 1947. The independence of the residual pressure from the pressure was described by Edwin K. Jaycox and Howard W. Weinhart at the Physical research department of Bell Telephone Laboratories, Inc., New York in 1931, and by Wayne B. Nottingham of the MIT (Massachusetts Institute of Technology) six years later, but their measurements were not used for the new form of ionizing gauge. Due to the independence of the residual current from the pressure, below 10^{-8} mbar there was no longer the linear dependence of the ion flux on the pressure at a given electron emission, which Dushman measured only between 10^{-2} and $4 \cdot 10^{-5}$ mbar.

Extension of the Low Pressure Range of the Ionization Gauge

ROBERT T. BAYARD AND DANIEL ALPERT
*Westinghouse Research Laboratories, and Physics Department,
 University of Pittsburgh, Pittsburgh, Pennsylvania*
 April 13, 1950

THE ionization gauge¹ has been generally considered useful for the measurement of gas pressures ranging down to 10^{-8} mm Hg.² This low pressure limit is not the lowest pressure attainable with modern vacuum techniques, but has been shown to be a limitation of the conventional ionization gauge itself. An investigation made in this laboratory to determine the cause of this limitation has resulted in a new ionization gauge whose range has been considerably extended. The new gauge has been used to measure pressures of the order of 10^{-10} mm Hg.

The conventional ionization gauge resembles structurally the triode vacuum tube. The grid, however, serves as anode and is operated at a positive potential (100 to 250 v), while the plate is negative (10 to 50 v), both with respect to the cathode. Electrons from the cathode, before being collected at the grid, can create positive ions by collision with gas molecules. The number of ionizing collisions for a given electron current is considered to be proportional to the gas density. The current to the ion collector, or plate, is thus a measure of the pressure.

Figure 10-7 : Title page of Alpert's discussion Extension of the Lower Pressure Range in the Ionization Gauge published in Review of Scientific Instruments in 1950.¹⁴⁰¹

The problem was clearly set in Nottingham's paper at the 7th Physics Electronics Conference at MIT in 1947. The following year, the problem was re-addressed. In the summer of 1948, Alpert from

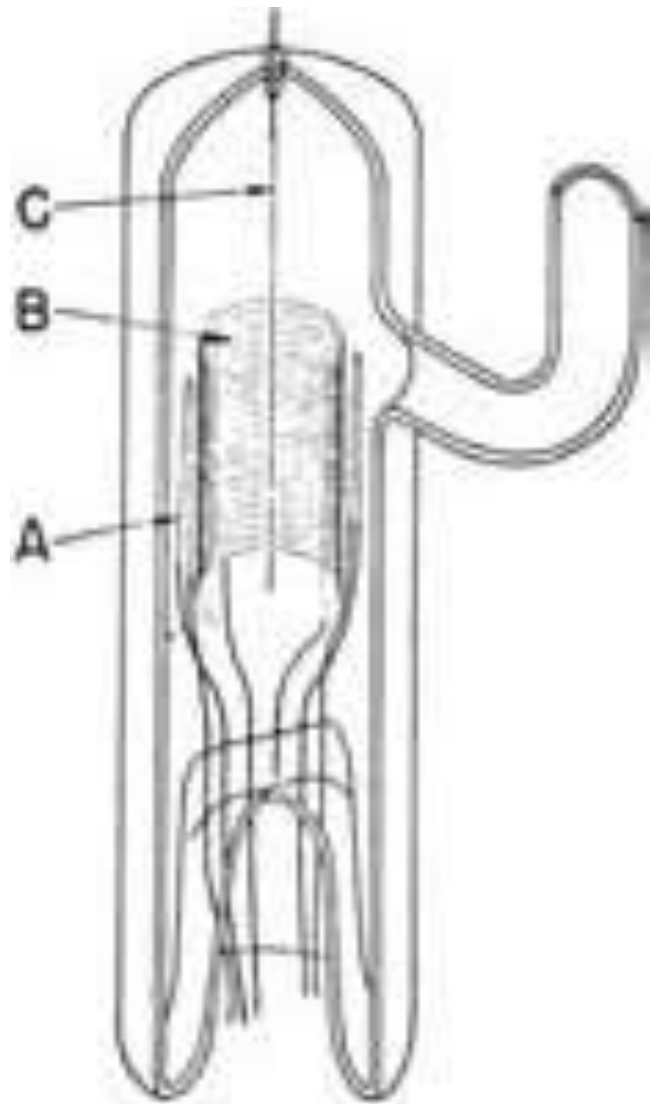

Figure 10-8: The original form of the Bayard-Alpert fiber ionization pump A, grid B and collector C.¹⁴⁰²

Westinghouse's Research Laboratories asked Robert T. Bayard to investigate Nottingham's presumption. It was not necessary to wait much longer for the solution that Alpert introduced at the MIT in 1950. Instead of a cylindrical plate in the pump axis, he used an ionic collector from a thin conductor in the pump axis, which greatly reduced the flow of soft X-rays from the grid (Figure 10-18). By reducing the surface of the ion collector, it was possible to measure down to 10^{-11} mbar, which was the pressure due to the residual X-ray radiation flow on a thin conductor. At the same time, he proposed the use of purely metal valves for insulation of the system from pumps used at higher pressures, and the introduction of an ionization gauge as a main pump at low pressures. With this, the autonomous development of pumps and their

¹⁴⁰¹ Madey, 1984, 145.

¹⁴⁰² Redhead, 1984, 34.

meters merged into a single device after three centuries of separate developments. The competition between ultimate vacuum researchers and their measurers had shifted into cooperation. Something like the merging of magnetic and electric research after Oersted's experiment of 1819, or the merging of all known radiations in Maxwell's theory of 1873. The initially independent development of pumps and gauges finally combined into a single device after three centuries of competitions. The modern era just loves the universal devices like smartphones.

Paul Aveling Redhead has completed his physics education in Cambridge when he was twenty years old. By 1947 he was researching microwave cathode ray tubes for the British Ministry of the Navy, and then went to the National Research Council in Canada.

The collectors were hunting gas ions, thus lowering the pressure, which should be measured; this was of course a serious disadvantage of ionizing gauges. Alpert used the problem to improve the pump; the trouble provided advantage, just like the initially annoying sputtering on the glass walls of cathode ray tube. At the same time, Alpert proposed the use of purely metallic valves for insulation from pumps used at higher pressures, and the use of a low-pressure ionization gauge for the main pump¹⁴⁰³.

Daniel Alpert received his doctorate in physics at Stanford in 1941/42. In Westinghouse's laboratories he led the research team until he went to the Illinois University in 1959. The discovery of Bayard-Alpert manometer revealed that they had already reached 10^{-9} mbar in 1931, although such a low pressure could not be measured in those times. Alpert's ideas were developed in trap pumps that trapped gas molecules on surfaces within the system without removing them. The improvements soon reduced the vacuum limit from 10^{-8} to 10^{-11} mbar in the Redhead modulated meter from 1960 and the "extractor" of 1966 (Figure 10-8).

10.7 Cold Cathode Ionization Meters

Penning used a cold cathode at Philips in 1937. In a mutually perpendicular electric and magnetic field it received Townsend's discharge, the flow of which was often a nonlinear function of pressure. Penning's pressure gauge measures down to 10^{-6} mbar, and by improvements after the Second World War down to 10^{-12} mbar.¹⁴⁰⁴ Simple measuring devices of this type have been widely used as they surpassed McLeod's tools with their fast achieved, uninterrupted and nicely transparent results. Due to non-linearity and occasional errors, Penning's measurements were not very accurate, but they are useful for the industry for pressures between 10^{-2} and 10^{-7} mbar (Figure 10-9).

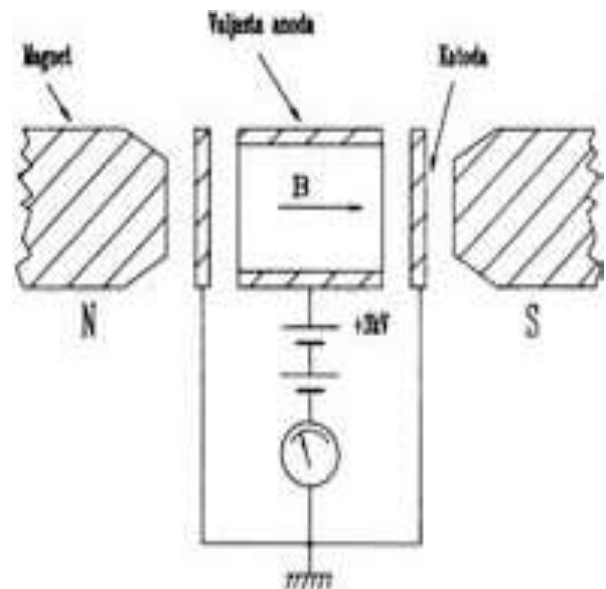

Figure 10-9: Schematic presentation of the Penning Cold Cathode ionization meter¹⁴⁰⁵

For a Manhattan project of manufacturing atomic bombs between World War 2, Backus and colleagues developed ionization meters with the cold cathode. In 1943 or 1944, they invented a vacuum meter in the vacuum system with a mass spectrometer that began to sell at the end of the war. In the 1950s, it was found that the crossing of the fields corrected the defects of the Penning manometer, and the modified cathode model improved the capture of the electrons. The advanced manometers on the cold cathode could measure down to 10^{-14} mbar.

¹⁴⁰³ Lafferty, 1998, 417, 626.

¹⁴⁰⁴ Redhead, 1994, 33.

¹⁴⁰⁵ Šetina, 1993, 64.

Table 10-1: Vacuum by the middle of the 20th century: the table gives an overview of the development of pressure gauges up to the middle of the 20th century.

Time	Inventor	Measurement type, and measured object	Measurement range (mbar)
before 1660	Boyle, Hooke	direct, liquid	1000–0,1
1874	McLeod	Compression	10^2 – 10^{-7}
1897	Sutherland	viscosity, with torsion gauge	1 – 10^{-4}
1906	Hogg	viscosity, with torsion balance	
1906	Pirani	Thermal conductivity	1000– 10^{-4}
1906	Voege	thermal conductivity, with thermocouple	1000– 10^{-4}
1909	von Baeyer	ionization of hot cathode	10^{-3} – 10^{-8}
1910	Knudsen	transfer of momentum	10 – 10^{-3}
1913	Langmuir	viscosity, on a swinging fiber	1 – 10^{-4}
1917	Lorenz	direct, mechanical, on Bourdon tube	1000–30
1929	Olsen, Hirst	direct, mechanical, capacitive	10 – 10^{-4}
1937	Penning	ionization, on a cold cathode	10^{-3} – 10^{-6}
1946	J.R. Downing, Glenn Mellen of National Research Corporation, Boston, Massachusetts	ionization, cold cathode, radioactivity	300– $5 \cdot 10^{-4}$
1950	Bayard, Alpert	ionization, on hot cathode	10^{-4} – $5 \cdot 10^{-12}$

11 New Thin Films Materials: Sputtering, Condensation, Evaporation, Blistering

11.1 Experiments with the Sputtering of Metals and Thin Films in the 19th Century

11.1.1 *The Discovery of the Sputtering of Metals in England*

The thin films were noticed already after the explosions of the conductors through which Leyden jars were discharged. Englishman John Canton applied a metal conductor to glass, ivory and wood. After the explosions, he got the rainbow-colored coils, which were not as correct as in Priestley's experiments. The rubbing or electrification of the glass substrate did not affect the experiment. Priestley also experimented with explosions in a vacuum even though his pump was not the best. Unlike other explosions, his substances did not fly only in one direction.¹⁴⁰⁶ Thus, it would have been "possible" to notice the sputtering of metals in those times; but the amounts of dispersed material are small, phenomena are carried out on an atomic level, while the researchers were not able to observe the effects of electrical currents for a sufficiently long time before Volta's discovery of the electric battery at the beginning of the 19th century.

Nearly a century after Priestley, people were closely watching accompanying sputtering phenomena during the exploration of "cathode rays". The surface of the cathode is exposed to the plasma ions that strike atoms at the cathode. Grove first connected sputtering to metal layers on the walls of the glass tubes after discharge (Figure 11-1). Only a little after him Robida reported about his similar research.

In 1848, Grove and Gassiot jointly investigated the melting of platinum electrodes. The Parisian academician César Mansuète Despretz told Grove

about the stronger inductors made in Ruhmkorff's Parisian workshop. With his advanced equipment in London, Grove was ready for a famous experiment, reported to RS immediately after the new year of 1852. The report, which paved the way for modern thin-layer technologies, was published on the first of April like a jokers' day. In fact, it was deadly serious. Grove first saw the accumulation of metal on the walls of the emptied tube after the discharge of the Ruhmkorff's inductor. The metal oxide shade was like that of a fashion photographer Frenchman Daguerre, who had just died at that time. Grove knew the photograph well, since he had been exploring it with Gassiot in a previous decade; recently Grove defended the "Daguerreotype" patent in England as a lawyer in court. Thus, Grove had a rare chance to use his legal and later judicial experience in experimental physics.

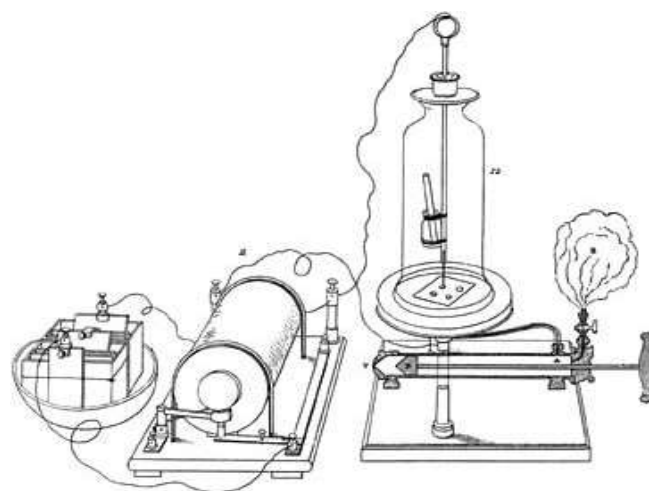

Figure 11-1: The schematic illustration of the device with which Grove investigated the discharges in gases, and in 1853 for the first time noticed the phenomenon of cathode sputtering.

When Grove switched the electrodes, he could completely remove the sputtered stain. There were no other metals in the sealed tube, so it was assumed that the cathode rays disperse the metal particles from the electrode, which are then collected on the glassy sidewalls (Figure 11-2). Grove observed his stain through an achromatic microscope at two hundred times magnification. He was aware that he is following a new phenomenon in which he will clear up an important similarity between the electrolysis and the discharges in a vacuum.

¹⁴⁰⁶ Priestley, 1769, 218. Priestley, 1966. 2: 334, 359, unpagged appendix on the end.

Three weeks later in the addition to the initial discussion, Grove offered several explanations by analogy with Nobili's research of thin films produced in electrolysis.¹⁴⁰⁷ He has prophesied many interesting discoveries and proved that the actual transfer of atoms of platinum during discharge is a matter of fact. His important discussions were translated by Germans for their *Ann. Phys* (Figure 11-3).

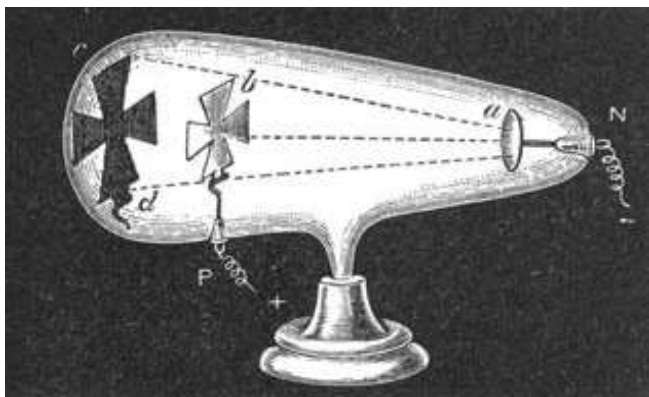

Figure 11-2: A shadow of "cathode rays" with a Maltese cross

VII. *On the Electro-Chemical Polarity of Gases.*
By W. R. Grove, Esq., M.A., F.R.S.

Received January 7.—Read April 1, 1852.

THE different effect of electricity upon gases and liquids has long been a subject of interest to physical inquirers. There are, as far as I am aware, no experiments which show any analogy in the electrization of gases to those effects now commonly comprehended under the term electrolysis. Whether gases at all conduct electricity, properly speaking, or whether its transmission is not always by the disruptive discharge, the discharge by convection, or something closely analogous, is perhaps a doubtful question; but I feel strongly convinced that gases do not conduct in any similar manner to metals or electrolytes.

In a paper published in the year 1849*, I have shown that hydrogen or atmospheric air intensely heated, showed no sign of conduction for voltaic electricity even when a battery of very high intensity was employed.

In the Eleventh, Twelfth and Thirteenth Series of FARADAY'S Experimental Researches, the line of demarcation between induction across a dielectric and electrolytic discharge is repeatedly adverted to; induction is regarded as an action of contiguous particles, and as a state of polarization anterior to discharge, whether disruptive, as in the case of dielectrics, or electrolytic, as in electrolytes. See §§ 1164—1298—1345—1368, &c.

Figure 11-3: Grove's discussion on the discovery of metal sputtering.¹⁴⁰⁸

In 1854 Faraday performed similar experiments and reported them to his friend Plücker in Bonn. Three years later, Faraday observed sputtering during the "explosion" of a metal wire in a vacuum, while at the same time thin films were studied by Plücker and the native Carniolan Robida. The first studies provided mainly qualitative findings on the duration of the loading of the thin layer and its position by the electrode.

¹⁴⁰⁷ Grove, 1852, 87, 89, 90, 94—95, 10; Bowers, 1998, 114.

¹⁴⁰⁸ *Phil. Trans.* 142 (1852) 87.

William Robert Grove was at home in Swansea in Wales. He learned his basic from his domestic teachers, then attended the Brasenose College in Oxford and graduated in 1832. In 1835 he was called to the bar by the Londoner Lincoln's Inn. Between 1840 and 1847 he was a professor of "experimental philosophy" at RI, where he used Zn-Pt cells to illuminate his lectures. In 1846, he published a high-profile book on the Conservation of Energy. From 1853 he served as a lawyer primarily in technical cases and became a judge of the High Court in London. In 1872, the queen elevated him to a noble rank. Because of poor health, he abandoned his job and devoted himself to science in 1887. The basic principles of the fuel cell H₂-O₂ technology was published in January 1839 by the German professor in Basel Christian Friedrich Schönbein (1799 Metzingen in Swabia-1868 Baden-Baden) in *Phil. Mag.* Grove's HNO₃ battery was most commonly used in telegraphic devices until it was found to be hazardous because it leaked the dangerous NO₂. Grove's "gas voltaic cell" from 1839 was the predecessor of modern fuel cells. In it, the electrolysis process was turned upside down to bind oxygen to hydrogen for production of water and electricity.



William Robert Grove (* 1811; † 1896)

That is why Faraday directed Gassiot to explore the interactions of cathode rays with metals. Gassiot was a wealthy wine dealer, much like a younger brewer Joule; so, a good droplet again played a decisive role in the English discoveries of the time. On March 3, 1858, Gassiot proved that "small particles" were secreted into the side of the

negative electrode, otherwise than in the voltaic cell; therefore, the light of the inductor's discharge cannot in any way be derived from the emanations of metal particles.

Other than in Davy's and other studies of discharges, in Geissler tube, the particles of metal are sputtered from the negative electrode, and they do not reach positive electrode at all. According to Gassiot, sputtering of the cathode from platinum cannot cause light phenomena in the discharge of the tube, since it does not have the same direction in space. He prevented the formation of metal sediment on the glass wall around the cathode of the emptied tube, in front of which he placed an additional open tube with a smaller diameter. The cathode was then cold and undamaged. Crookes found that thin films cannot be easily mechanically separated from the substrate or obtained by compression.¹⁴⁰⁹

Gassiot was a wealthy wine merchant and amateur scientist. In the 1860s he supplied Maxwell with the devices needed to prove the equivalence of electromagnetic and light velocity. Gassiot was the vice-president of the RS. Among the first in England, he acquired Geissler's glow discharge tube filled with dilute gas and produced his own inductor.

11.1.2 Measurements in Germany and Austria

11.1.2.1 Plücker in Bonn

Plücker introduced a mathematical spirit in experimental research and described a vacuum as an unattainable limit. After exploring discharges in diluted gases, at Christmas of 1857, and again few months later, he declared that during discharge he could "glue, silver or cover the glass walls of the discharged tube with galvanic flow". Gassiot's measurements confirmed his opinion that the particles of metal originate only from the negative electrode. On the inner wall part of the closed emptied glass containers, we always find the same type of metal as at the negative electrode. The wall of the vessel is so dark due to the accumulation of

an extremely thin layer of platinum from the cathode.

Julius Plücker from Elberfeld in Prussia studied in Berlin and Paris. In 1825 he received his Ph.D. and became a private assistant professor of mathematics and physics in Bonn, and in 1828 he was an associate professor there. Despite criticisms that the university already has enough mathematicians, Plücker attracted many students with his mathematical treatment of physical problems. In 1834, Plücker received a regular full professorship in Halle, and in the following year he became a professor of pure mathematics and mechanics in Bonn. After the death of his professor of mechanics and experimental physics K. von Münchow, he also temporarily took over the cabinet of physics. Since the Prussian ministry could not obtain a suitable professor of physics for a long time, there was one of the most interesting combinations in the history of science: the mathematician Plücker lectured in a full course of experimental physics the summer of 1842 and began his research work. Thus, in Plücker's networks, the important research in geometry and experimental physics challenged each other. Since he did not have a laboratory for students, he used to invite students to his home-based laboratory, where Hittorf from Bonn, later professor in Münster, assisted him for some time. After Plücker's death, Clausius took over Plücker's chair and the physics laboratory in Bonn and Hertz did the same later to his own perish.



Julius Plücker (* 1801; † 1868)¹⁴¹⁰

¹⁴⁰⁹ Gassiot, 1863, 134, 137; Plücker, 1858, 67; Hittorf, 1869, 197–198, 210–211; Hittorf, 1884, 126.

¹⁴¹⁰ Sparnaay, 1992, 62.

The charged sputtered particles collected on the walls of the vessel in clear forms or mixed with the gas particles. Plücker curved their trajectories with a magnet, and only blacked the individual parts of his cathode ray tube. He reported particularly beautiful mirrors from platinum on a leveled basis.

He noticed that the particles from the heated platinum cathode sputtered toward the anode. Therefore, the interior of a sufficiently small discharged tube is covered with a fine mirror in which one can chemically prove platinum. He altered the admixtures of gases in the emptied tube and found that thin disks did not form disruptions in the fluorine and boron. He had a very thin layer of platinum blue, like a thin layer of gold. He got a nice mirror with a zinc electrode which almost certainly impressed the Bonn native beauties. He investigated the formation of thin films of different thicknesses and lengths at the electrode in the tube.¹⁴¹¹ Without knowing Grove's research,¹⁴¹² he announced that the bombarding with cathode ray can be used to sputter very thin metallic films:

"The wall of the container is blacked by the fine metal particles. The layers of large thickness make fine metal mirrors. They are like the fine particles of gold, which Faraday studied in 1857. With zinc we get a nice mirror on the parts of the glass tube opposite the zinc electrode. This mirror has shaded shadowed boundaries in the pipe. Thus, with a new series of experiments, we can learn about the new optical characteristic of thin sputtered metal.

The blackening of glass is reduced if the thin wire of the negative electrode is replaced by a thicker one. Then there will be no additional excessive heating electricity. The stronger flow of metal particles from the thin wire formed as negative electrode is not only due to the smaller surface, but also to the greater heating due to which the electric current is more concentrated."

Geissler sometimes only partly inserted the platinum electrode inside of the cathode ray tube. He observed the sputtering only on part of the

inner wall of a thin glass tube within the electrode's reach.¹⁴¹³

In 1877, Wright, a professor of experimental physics at Yale, designed Plücker's similar method for applying thin metal layers, which we still use today.¹⁴¹⁴ Four years later, he became a member of the National Academy of Sciences (NAS). The dispersion of plasma ions was no longer just a damaging phenomenon that destroys cathodes and pollutes plasma, for example, in fusion reactors. We can use it for cleaning and etching surfaces of solids, for the application of thin films and for surface analyzes. Once annoying occurrence became a profit of its own, as it frequently happens in applied sciences resembling the bothering moulds which suddenly transformed into Fleming's antibacterial properties of penicillin.

11.1.2.2 Hittorf in Münster

Plücker mainly investigated the spectra of diluted gases, while his student Hittorf in Münster was interested in the electrical conductivity of gases at low pressures and higher temperatures. At the distance between the electrodes 1 to 2 mm, he glowed a platinum electrode 1/2 mm thick. The metal from the cathode sputtered the mirror on the glass.¹⁴¹⁵

The sputtering of the platinum from the electrode to the glass less disturbed the measurement in larger tubes like Ruhmkorff's 40 cm long spark at the exhibition in Paris. In the spring of 1867 Plücker experimented there among Parisians, and Hittorf did the same in September.¹⁴¹⁶ In 1884, Hittorf found that most of the metals sputter from the cathode before they reach their melting point. The platinum is dispersed when the spiral of the conductive stream in the tube receives the color of the yellow glow. For 2 mm thick cathodes made of aluminium, Hittorf used as many as 1000 Bunsen batteries connected at a pressure of 2 to 3 mm Hg. The pulsating discharge covered a glass wall with a thick gray mirror in a beautiful marine green color within a few seconds.

If the cathodes from aluminium were not totally sputtered, their surface became rough, full of thin

¹⁴¹¹ Plücker, 1896, 518, 602, 614, 651; Plücker, 1857, 88–106; Plücker, 1858, 67, 68, 70, 113, 117; Anderson, 1968, 31.

¹⁴¹² Bunshah, 1994, 939.

¹⁴¹³ Plücker, 1858, 68, 69; Jungnickel, McCormach, 1986, 235.

¹⁴¹⁴ Rosenberger, 1890, 781; Anderson, 1968, 31.

¹⁴¹⁵ Hittorf, 1869, 210–211; Hittorf, 1884, 125–127, 130

¹⁴¹⁶ Hittorf, 1869, 202, 210.

tips. The anode remained unchanged. Hittorf described the sputtering of usable mirrors made from copper. Unfortunately, the marketing of such expensive mirrors was initially not available, so researchers treated them a disruption phenomenon. Only a few Prussian blue-haired maids could have dreamed of such mirrors as their beauty tools.

Unlike Puluj and other contemporaries, Hittorf has not yet distinguished between the vapor deposition and sputtering. He erroneously used the term "vapor deposition" for the ionization sputtering in which each ion spills a certain number of atoms from the cathode, which are then loaded onto the vessel wall. The mechanism of sputtering was explained only half a century after its discovery, and another half of the century passed before the first quantitative models were proposed.

11.1.2.3 Robida in Klagenfurt

The most important physicists of the Slovene genus of the late 19th century, Stefan and Klemenčič, did not publish papers about cathode rays, although Stefan encouraged the efforts of his Viennese assistant Puluj. Simon Šubic published more about Geissler's tubes. Crookes influenced even the research of Zoch in faraway Sarajevo. The most important Slovenian researcher of cathodic sputtering was Stefan's Klagenfurt gymnasium professor and principal teacher, the Benedictine Karel Robida. He considered that the vacuum is a complete electrical insulator, although a total vacuum cannot be achieved.¹⁴¹⁷

Robida was unable to perform difficult experiments without proper pumps and seals, since in 1857 he had not yet acquired Geissler's cathode ray tube. That is why he referred to the experiments of Berliner jeweller Riess from 1838, who had very poor reputation among the Viennese researchers even if he became the first Jewish member of Berliner academy in 1842 and a father-in-law of Quincke two decades later. Robida did not mention similar surveys of Berliner Professor Erman announced in 1802. Both considered that only the magnetic properties of a natural magnet are permanent, while the electrical properties are not, as each substance is discharged over time.

Three decades before Hertz, Robida published qualitative measurements of the electromagnetic wave detection from a charged electroscope of Fechner and from the dry cell of Zamboni. Grailich's assistant at the Viennese Physics Institute, Blaserna could not repeat Robida's detection of electromagnetic waves with the Fechner's electroscope after rubbing a metal plate with a violin bow in 1858. Therefore, he rejected the supposed discovery of electromagnetic waves, and Grailich was offended by Robida's bizarre experimentation. Stefan did not answer, although he closely collaborated with Grailich as a Viennese assistant professor of mathematical physics and assumed Grailich's position after Grailich's sudden death.

Karel Lucas Robida from Mala Vas (Small village) no 2 near Ježica, now part of Ljubljana, studied at a gymnasium (Grammar school) and then visited Lyceum in Ljubljana until 1824. In 1829, he joined the religious order of Benedictines and after the ceremonies accepted the religious name Karel in the Benedictine monastery St. Paul in the Labotin valley, just at the then Carinthian regional and Slovene linguistic border. In 1830, Robida completed his theological studies and passed the exams for the teacher. Between 1807 and 1871, the Benedictines led a Lyceum and then a Gymnasium in Klagenfurt. From 1830 to 1845, Robida taught at the Gymnasium in Klagenfurt, and after Kobentar's death, he took up a chair for physics on the Lyceum in 1847. In Klagenfurt, he lectured on physics and mathematics for twenty-seven years, until his retirement in 1874. He published a total of ten papers about physics and a first book on physics in the Slovenian language in 1849. He published also theological, popular scientific and practical scripts, mostly in the Slovene language.

With his vibration theory of longitudinal waves of the electrons, Robida explained the phenomena in the discharge of the fifty elements of the Grove's cell through the platinum electrodes in the exhausted vessel. As the first Slovenian researcher, he sputtered a pin-point electrode from platinum and "made a white round spot from a giant number of platinum grains, which at the higher temperature

¹⁴¹⁷ Robida, 1857, 5, 11, 12.

captured the plates ... The stain was whiter if the platinum particles lay closer to each other".¹⁴¹⁸

Robida published his paper five years after Grove's discovery of metallic cathode sputtering and several months before Plücker's descriptions;¹⁴¹⁹ it is therefore desirable to read the Robida's description of experiments:

The deposited excreted substance forms the ring of a very correct shape on the negative plate by the positive (electrode). The center of the ring is the projection of the tip to the plate. That occurs both in the horizontal and the vertical position of the panel, therefore there is considerable focusing of the motion of matter from the positive towards the negative pole. After the discharge of the fifty elements of the Grove cell in a heavily exhausted air, while the platinum plate is positive, and the tip is negative, at first there is a bluish, completely round stain immediately under the Nobili's coils.¹⁴²⁰ The same stain is observed (after discharge) in the atmosphere, but they are closer to each other, have a smaller diameter and much less vibrant colors. When we turn the pole, the plate receives from the positively charged peak (electrode) a white circular stain, composed of the huger number of platinum grains that have taken on the plate at higher temperature. In the diluted air the stain became much larger than in a (total) vacuum. The (electrode) tips of iron, silver, and copper give similar results. Positive electrodes from silver and copper plates show very distinct indentations. The tip and plate made of copper give the arc in beautiful green light. If both tips are of the same metal, only the positive will glow throughout their length.

Neeff experimentally determined which pole emits light and which emits heat. By using a microscope, he distinguished two kinds of light. The first consists of the intangible small points of vibrant shine, which are stuck on platinum when the plate or tip of the platinum conductor is a negative pole. The points of light are very thin tips of rough surfaces whose light in electric power produced by friction is called light spike. Neeff called another type of light a fire that appears in a weak violet color. It appears on the tip as a glossy envelope

and lies in its plane on the plate. A similar light phenomenon also moves from a negative pole; the least it is, the more it is white. The more pronounced it is, the more it turns purple. Because light is emitted exclusively on the negative pole, according to Neeff, heat is eliminated primarily on the positive pole. The Parisian mathematician Moigno argued that the source of light is most evident when using Ruhmkorff's inductor. The platinum spheres are poles half of the induction current in the vacuum. The negative sphere is bright and relatively cold, and the positive is dark and relatively warm.

Christian Ernst Neeff (Neef, 1782-1849) was a professor at Frankfurt am Main until he passed away. In 1839 he compiled a standard short circuit breaker for small inductive coils. It operated on the same system as a hammer with an electric bell. Neeff mainly researched in electromedicine. According to Goethe's example, he developed the cooperation in natural science, technology and industry in Frankfurt since 1824. He was a Doctor of medicine and a physician in the city hospital, director of the botanical garden, co-founder of the Society of German Naturalists and Physicians, the founder and first president of the physical society.

Robida used his and Grove's somewhat obsolete wave (vibrational) theory to explain the thermal behavior of electricity. The intense fluctuation of the flow sources converges into a small number of elementary waves that carry particles unsuitable for electric oscillations. Therefore, there is a positive electricity of heat fluctuations (vibrations) and negative electricity of light fluctuation.

The vibrations of particles of the body causes heat. From here we have heat acquired by friction, collision, impact. We've already seen thermal fluctuations causing the electricity. On the contrary, we observe electric vibration, which causes heat fluctuation. When melting electrical conductors, electric vibrations with heat fluctuations increase the volume and the motions of particles. The temperature of the conductor is below the melting point and the already melted surface layers are reflected. It seems that these layers accumulate the substance only on the negative electrode, and they are taken it away from

¹⁴¹⁸ Rosenberger, 1890, 775; Robida, 1858, 59; Robida, 1857, 4, 31, 33; Graulich, 1858, 426.

¹⁴¹⁹ Grove, 1852, 90; Plücker, 1857, 105.

¹⁴²⁰ Nobili taught physics in Archducal Museum of Florence.

the positive electrode. Moigno did not notice the warming of the positive electrode, nor did the flying away of the oscillating particles in the direction of the oscillation which deposes on the negative electrode.

The fluctuation of light in which the less intense light stimulated electrical vibrations was noted in electrochemistry. Because of electric oscillation, the oscillation of light is directed towards the negative pole.

Light waves arise from electric elemental waves and cover the surface of the slab of negative pole and wrap the tip of the negative pole. The formation of coils or round spots on the electrode allegedly confirms that Robida's explanation of the electric current.



Figure 11-4: The title page of Robida's discussion of the vibrational (wave) theory of electricity, printed in the 1857

If one electrode is a plate, and the other one is conic, then the center of the ring coincides with the extension of the tip. In the diluted air the stain on the positive plate is vivid and wider than the atmospheric air. The slab on the negative plate consists of platinum grains and is greater in the diluted air than in a vacuum.

Light expands easier in the rarer air, while heat expands easier in the denser air. The stain is whiter the as parts of the platinum lie closer to each other

and gets more purple as the fluctuation of light increases..." (Figure 11-4).¹⁴²¹

In his Grammar School Report Robida observed cathodic sputtering, since the material from the negative tip was deposited on a positive electrode.¹⁴²² Due to Grailich's criticism of Robida's work, there was no special support of Robida's claims because Ettingshausen's son-in-law Grailich acted as a leading representative of the distinguished Viennese institution. Robida's subsequent atomism and, basically, his controversy with Clausius in the famous mathematical-physics journal of Leipzig, had a far greater impact, which certainly influenced Robida's high school student Stefan.

11.1.2.4 Reitlinger and Wächter in Vienna

Stefan's chief executive, Ettingshausen, acquired the Geissler's glow discharge tube filled with dilute gas for their institute very early.¹⁴²³ He noticed that the color of the vacuum in the cathode ray tube depends on the type of gas contained. In the narrower parts of the tube, he detected the interrupted light, and in the wider parts of tube there were fine nice layers.

Already Plücker's research has shown the dependence of the spectrum on the type of gas and on the thickness of the cathode-ray tube. Ettingshausen commissioned Reitlinger to investigate this phenomenon and handed him several cathode-ray tubes and Ruhmkorff's inductor. During his measurements, Luka Žerjav helped Reitlinger. One finding of a multi-year research was that the vacuum was an isolator for light and heat, which Huygens and other early pioneers already noticed in their less sophisticated ways.

In 1861, Reitlinger adjusted his optics so that he could observe two spectra from various Geissler's cathode ray tube and compare them with each other. He confirmed the assumption of the metallic nature of hydrogen and noticed very beautiful layers, which he called "pearls". He influenced the

¹⁴²¹ Robida, 1857, 31–33.

¹⁴²² Robida, 1857, 31.

¹⁴²³ Reitlinger, 1861, 16.

distribution of light and dark layers by a magnet (Figure 11-5).¹⁴²⁴

The Austrian **Edmund Reitlinger** first studied mathematics and astronomy, and then he matriculated at the faculty of law. In 1855 he studied physics at W. Weber's class at the University of Göttingen. In 1849 Weber returned from Leipzig to Göttingen after twelve years of exile because he signed a political petition. In 1858, Reitlinger received his doctorate at Ettingshausen's lab in Vienna and became the assistant professor at the Viennese Physics Institute next year. Reitlinger expanded his lectures on the history of physics, inductive logic and the theory of physical research, when after Mach's departure to Graz, he took over his Viennese lectures for medical students. In 1863 he was a candidate for an associate professor in Graz. In 1865, Mach again recommended him successively for von Lang's successor in Graz, and in the following year Reitlinger became a professor at the Viennese Polytechnic and at the Technical College in addition to Victor Pierre and the Bohemian Finger, who earlier taught at the Higher Real school in Ljubljana between 1870 and 1874.

On July 24, 1862, Reitlinger and Luka Žerjav presented a discussion that crowned more than a year of their ongoing experiments at the Physics Institute.¹⁴²⁵

They found that the layers were denser at higher voltages, that the spots of stains depend on the cathode used, that the layers are lighter in a higher vacuum, and the width of the layer depends on the type of gas in the vacuum and the length of the tube.¹⁴²⁶

The light and dark layers of discharges in the cathode ray tube have already been described by the Dean of the Faculty of Natural Sciences in Marseille, Morren, in a letter to Moigno, which was also translated into German. The dean of the Bordeaux faculty of sciences Jérémie-Joseph-Benoit Abria (1811 Limoges-1892 Bordeaux) assumed that the layers in the vacuum cathode ray

tube were mechanical and not an electrical phenomenon. Reitlinger and Žerjav noted that the layers in Geissler's electrical glow discharges in the tube of diluted gases caused differences in electrical conductivity.¹⁴²⁷



Als die Schichtung des elektrischen Lichtes vor einigen Jahren viele ausgezeichnete Physiker beschäftigte, richtete Morren, Decan der naturwissenschaftlichen Facultät zu Marseille einen hierauf bezüglichen Brief an Abbé Moigno, der in dessen Journal Cosmos veröffentlicht wurde. Er schreibt die Schichtung vor Allem der Unzulänglichkeit (*sortout u l'insuffisance*) des gasförmigen leitenden Körpers zu, durch welchen der Strom geht. Das Phänomen der Schichtung selbst besteht nach seiner Ansicht in Induction und Seitenentladung gegen benachbarte leitende Körper. Um seine Ansicht besser verständlich zu machen, führt er Wahrnehmungen an, die man an Dräthen macht, durch welche mächtige Entladungen statischer Elektrizität gesendet werden. Wenn er Dräthe aus Platin, Silber oder Gold nahm, so wurde der Drath durch starke Entladungen zerstört. Morren schrieb dies Seitenentladungen zu, die der grosse Leitungswiderstand verursachte. Da er auf Papiercylindern, mit denen er die Dräthe umgab, geschichtete Spuren sah, so glaubte er in dieser Erscheinung die Grundlage zur Erklärung des geschichteten Lichtes zu erblicken. Selbst wenn die Zerstörung des Leiters durch seine Dicke verhindert wurde, nahm Morren geschichtetes Metall- oder Oxydstaub in dessen Nähe, z. B. in der Nähe einer Kupferkette wahr, wenn sehr starke Entladungen von Leidner Batterien hindurch gingen. Diese Spuren

Figure 11-5: The title page of Reitlinger and Luka Žerjav's paper¹⁴²⁸

Reitlinger harshly criticized Riess's assumption of the continuous translation of dark layers and the discontinuous translation of light layers in the emptied cathode ray tube.¹⁴²⁹ According to Reitlinger, due to the low conductivity of the bright layers, they heat up and, therefore, shine, as shown by experiments with spectral analysis. Riess, however, considered that the difference in brightness was due to the different density of gas in the cathode ray tube.

Reitlinger did not explain the formation of the substance layer in the cathode ray tube.¹⁴³⁰ Puluž considered that all the particles of different masses in the lighter part of the cathode ray tube are directed away from the cathode, while in the dark field they move in any direction. Since they have

¹⁴²⁴ Reitlinger, Žerjav, 1862, 361; Reitlinger, 1861, 15, 17, 20, 25.

¹⁴²⁵ Höflechner, 1994, 2: 50.

¹⁴²⁶ Reitlinger, 1862, 361, 354.

¹⁴²⁷ Robida, 1857, 29, 32; Reitlinger, 1862, 352, 356–357, 361.

¹⁴²⁸ Wien. Ber. II 46 (1862).

¹⁴²⁹ Reitlinger, Kraus, 1862, 374–375.

¹⁴³⁰ Reitlinger, 1861, 22, 24; Šubic, 1862, 109–110.

the same energy in equilibrium, there are three times more particles in the lighted part of the cathode ray tube than in the darker part.¹⁴³¹ So, the reason for the lower luminosity is the smaller number of particles and not the smaller number of collisions, as Crookes believed.

Auguste Morren was the first professor of physics working in the physics and chemistry laboratories of the Faculty of Science in Marseille, founded in 1854. He was the pioneer of spectroscopic analysis. In 1859, he made the first direct hydrocarbon analysis, although discovery was attributed to three years later Bertholet's exploration. Morren's and Abria's discovery was independently reiterated by Quet, rector of the Academy in Besançon, and at the same time by Grove in 1852. Gassiot also noticed the layering in the continuous discharge strong battery voltages. In 1861 he assumed that the fluctuation depends on the resistance of the medium. In 1856, Riess distributed the discharges among the continuous and discontinuous according to the conductivity of the media. Quet and the French Séguin distinguished the positive and negative layers. The railways technician Séguin was Montgolfier's grandnephew and student which stimulated the prestige of his ideas. In 1862 the physicist at the University of Geneva, de la Rive, measured that the dark space in the cathode better translated electricity than the light space. The professor at Leipzig and editor *Ann. Phys.* G. H. Wiedemann and Richard Rühlmann, professor at the Chemnitz Gymnasium, explained the layers in cathode ray tube with high speeds needed to enable the translation of the particles of gas. The discharge layers in the diluted gases were further investigated by Hittorf (1869) and Crookes in 1878-1879.¹⁴³²

Riess dealt with the translation of gases by analogy with translations in solid matter in a contradiction with then mainstream kinetic theory based on behaviour of gases. He advocated the one-fluid theory of electricity, while the Ettingshausen's school of both Stefan's and Reitlinger's direction preferred the hydrodynamic analogy. Thus, the controversy between Riess and Viennese physicists lasted more than two decades and marked three

generations of researchers: Ettingshausen, Reitlinger (1861-1862) and finally Wächter (1882). Reitlinger rightly criticized Riess's theory of anodic scattering and figures, which was discovered in 1784 by Lichteberg, a professor at Göttingen. Reitlinger argued that cathode sputtering is essentially different from anodic sputtering. Hittorf's and Wächter's (1882) idea of cathodic dispersion as evaporation of the cathode proved to be ineffective, just as Berliner's (1888) cathodic dispersion assumption about the evaporation of adsorbed gas, which extracts cathode particles with it.

Johann Puluž was an assistant in the c. k. Maritime Academy in Rijeka. In 1877, he habilitated at the University of Vienna and worked as a private assistant at von Lang's laboratory. He was also Kundt's assistant in Strasbourg, then a professor of physics and electrical engineering at the (German) Technical College of Prague. In Prague, he was mainly concerned with the fluctuation under the influence of his senior colleague Mach.

The Habsburgian researchers of vacuum discharges Reitlinger, Puluž and Wächter supported the claims of some English (Grove, Gassiot) and Westphalian researchers (Plücker, Hittorf), which were opposed to Englishman Crookes and the Berliner Riess. Of course, all the researchers relied on Faraday's authority.¹⁴³³ Reitlinger supported Grove's theory of the cathode-ray layer as developed by Gassiot in his Bakerian lecture in 1858. The contrary theory was published by French Gaugain, who considered that the speed of electricity was not constant, but it depends on the coefficient (refractive index), conductivity, the cross-section and the length of gas captured in cathode ray tube. Gaugain's theory was supported by Riess.¹⁴³⁴

After Reitlinger's disease and death, Friedrich Wächter continued research at his institute. He experimented with aeronautics and meteorology, led the Natural history museum, and collaborated with his Viennese TU classmate the officer Philipp Hess as a technical council in Technical Officer of the Technical Military Committee (technische Rāth

¹⁴³¹ Puluž, 1889, 242.

¹⁴³² Rosenberger, 1890, 3: 776–778.

¹⁴³³ Crookes, 1905, 113.

¹⁴³⁴ Reitlinger, 1861, 23–24; Rosenberger, 1890, 520–521.

in Technische beamte des Technische Militär-Komitees) specialized in electricity and military aeronautic balloon department (Militäraeronautischen Anstalt) from 1888 until the outbreak of war despite Wilhelm Kress' opposition.¹⁴³⁵ He endorsed Puluj's criticism of Crookes' (1879) idea that the average free path is equal to the length of the dark region in the cathode-ray tube. The critique was based on Stefan's determination of the average free path. Wächter advocated a dual-fluid theory of electricity, in which positive and negative electricity are qualitatively different. He studied in detail fourteen differences between anodic and cathodic sputtering, while criticizing Riess and others who equated both phenomena. Thus, the dispute between mono-fluidic (of Franklin, Riess, Thomson) and two-fluidic (of Schuster, Wächter) theory of electricity has dragged for more than a century (Table 11-1).

11.1.2.5 Puluj in Vienna and Prague

Jožef Stefan's Physics Institute in Vienna investigated the properties of gases, first diffusion and then thermal conductivity in the 1870s. Thin films were studied mostly by Puluj, who borrowed a large Ruhmkorff apparatus from the court councillor Stefan to carry out a series of experiments with Geissler's tubes. He observed:

"... changes in the dark space of the tubes when using electrodes from various metals: platinum, copper, silver, and zinc. In an induced flow of about 6 cm long sparkle, the glass surface is covered with a metal mirror in half an hour. The metal coating is the thickest near the electrode and perpendicular to the illuminated pulsating discharge.

The electrode is covered with a dust of a copper oxide, like golden dust ... Near the negative pole of the convex magnet, the light of the pulsating discharge in the tube is coated with the metal surrounding of the electrode together with a small part of the glass tube. If we use the electrode of platinum, we get a nice platinum mirror on the glass plate.

Aluminium is the only known metal ever, where we do not notice the sputtering of mirrors on the

¹⁴³⁵ Hof- und Staats- Schematismus der röm. kaiserl. Wien: Joseph Gerold, 1908, 313.

glass, because it is difficult to remove aluminium. The weak coating obtained using aluminium is only observed in phosphorescence ... Aluminium is less sputtered on glass due to its chemical structure or adhesion."

Puluj has not yet linked the properties of aluminium with its place in the new periodic system of elements. His problems with the sputtering of aluminium mirrored late discovery of pure aluminium by Oersted in 1824 and by F. Wöhler which made aluminium still very expensive in Puluj's times. Unlike Hittorf, he has already separated the dispersion from the sputtering:¹⁴³⁶

"With the horseshoe magnet we divert the dispersion to a smaller target. Against the platinum cathode, a mirror glass can be placed. A slight debris resulting from the sputtering of an aluminium electrode was attributed to impurities. Aluminium particles are also ripped from the cathode, but due to the difference in chemical composition or adhesion, they are not attached to the glass. There is no doubt that the cathode particles are tearing due to electric current and not due to evaporation and traveling at relatively high speeds. In doing so, they push the gas away from the cathode and diffuse into dilute gas. Since they move in one direction, their number must be three times greater than in the dark space, where they move with the same kinetic energy in all directions. The cathode space is relatively dark because there are fewer particles in it, and not because of the smaller number of particles in it, as Crookes claimed. Nor does Crookes' presumption hold that the dark space is equal to the average free path of particles in the gas, since this is much smaller in terms of Stefan's results. In the case of collisions, the particles of the electrode strongly shake the envelopes of the gas molecules, but do not heat them, while increasing their kinetic energy. Pulsed discharge is then a mixture of gas molecules and scattered parts of the cathode. At lower pressures, the dark room is longer and covers the whole tube at a pressure of 0.03 mm Hg but cannot reach 800 000 m/s, which Goldstein calculated m by his wrong assumptions. The fifty times lower pressure described by Crookes does not allow discharge at all. Pumping at high vacuum should be connected to the drying of the pump, since the main source of impurities are the

¹⁴³⁶ Puluj, 1889, 241–246; Crookes, 1905, 115.

adsorbed gases which the cathode eliminates after heating."

Plücker's ideas were particularly well received at the Technical College of Prague. In 1880, Gintl, a professor of chemistry, rejected Crookes' idea of cathode rays as the fourth aggregate state of matter. He believed that the rays always extract metal particles from the surface of the cathode. The particles are then moved in a straight line until the gas in the emptied tube changes the direction of their movement or absorbs them. According to Gintl, "cathode rays" are supposed to be a stream of metal particles that have been removed from the cathode.

Wilhelm Friedrich Gintl was born in Prague. Between 1867 and 1870 he was a private assistant to Lippich at the German University of Prague, and then he was a regular m/s professor of chemistry at the Technical College of Prague after 1870. He criticized Crookes' idea of the fourth aggregate state of the substance¹⁴³⁷ like many other who published in German language.

The later Gintl's colleague in Prague, Puluj, linked Gintl's hypothesis with the one-fluid physics theory of the professor of physics at the Swedish Academy Edlung: "A powerful stream of ether outbreaks the particles from the negative pole in the exhausted cathode ray tube. The extracted particles fly linearly towards the walls of the vessel. They cause an apparent glowing of matter and accumulate as a metal mirror on the wall of the vessel. In the collisions of these cathode particles along the walls of the vessel, their living force (*vis viva*, equivalent of modern kinetic energy) changes into heat. However, this heat is not large enough for phosphorescence. The ether which transport the particles of cathode therefore causes the phosphorescence on the wall of the vessel. The collisions of the negative electrical particles from the electrode along the glass wall and the collisions of the substance molecules equate the pressure of the ether between the particles of the vessel and the molecules. The collisions on the ether envelope make the center of the new waves of the ether from each point of the hit glass wall of the vessel, which finally show up as the phosphorescence."¹⁴³⁸

Puluj's theory was based on material atoms with an envelope from the ether. In 1857, such a model of the atom, called "Dynamide", was introduced by Redtenbacher and in the Habsburg monarchy Redtenbacher successfully competed with Clausius's kinetic theory, first published in the same year.

After Puluj, in 1883 Plücker's student Hittorf supported the assumption that metal particles originate from heated cathode and then they sit on the walls of a glass tube. In 1897-1898, the Swedish professor Gustav Grandquist proved that temperature change of cathodes on a wide interval do not affect the intensity of sputtering of metals in the emptied tube. With this Hittorf and Puluj's hypothesis was rejected.¹⁴³⁹

11.1.2.6 Optical Properties of Thin Films in Strasbourg

Interference colors of thin films were one of the pillars of Newton's optics in the 17th century. Jamin and Fizeau's experimental methods and Drude's theory enabled the use of accurate methods for measuring thickness in the 19th century. At the end of the 19th century, the discharged cathode ray tubes and high voltage rectifiers became accessible to the upper secondary level schools. Nevertheless, the properties of thin films made outside of the vacuum were initially studied.

The thinness of thin gold sheets has already been studied by Young. The research was continued by the British astronomer de la Rue in collaboration with Faraday, who studied the transparency of thin sheets of all kinds of metals obtained by chemical and electrochemical methods in 1857. His discharged Leyden jar sputtered a golden conductor on the glass formed as a golden leaf. In Berlin, Quincke studied the thin layer density in air and in vacuum. Stefan has published important research on the optical properties of the interference rings of thin mica leaves.¹⁴⁴⁰

In 1884, Kundt conducted the first studies of magnetic thin films of iron, cobalt, and nickel in which he measured the rotation of the polarization plane. In November 1885, he used a device resembling the American Wright's tool for

¹⁴³⁷ Rosenberger, 1890, 780.

¹⁴³⁸ Rosenberger, 1890, 780–781.

¹⁴³⁹ Sigmund, 1981, 12.

¹⁴⁴⁰ Faraday, 1857, 145; Quincke, 1863, 369, 384; Stefan, 1864, 135–137.

observing the high-quality interference rings in layers of various metals scattered from the cathode in September 1877. A ten inches long vertical glass cylinder was closed on both sides with smooth glass plates. From the bottom side, an aluminium electrode was deposited, and from the top Kundt inserted a metal cathode, intended for sputtering, which was attached to the tube by rubber, so that it could be changed during the measurements. It triggered a large induction apparatus with three to six Bunsen elements. Kundt used various metals, but his experiments were most fortunate with platinum. In the case of a cathode, 2 cm long, with a diameter of 0.2-0.5 mm, a horizontal plate was placed at the distance of 2 to 12 mm. He carefully removed oxygen and water vapor from the vessel. Even with the microscope, it was not possible to find the inhomogeneity of the cone-shaped mirror thus obtained with an average thickness of 10 nm and a maximum thickness just below the cathode. Kundt's discovery is today widely used in magnetic sensors and magnetic memories. This phenomenon was first observed by Faraday in 1845 and is still called by him today. In 1876, John Kerr reported about the polarization rotation of light, reflected from the magnetized surface.

Kundt experimented in vacuum in Strasbourg together with Puluj. In 1888 he replaced Helmholtz as a professor of physics at the Berlin Physics Institute. Kundt was surprised by the discovery of a double refraction (birefringence) of light reflected at boundary between the metal and the glass surface of the mirror. The thin layer was described as a crystalline elastic membrane that is unevenly tensioned due to the charge of the dispersed particles and therefore causes a double refraction. In 1888 he measured the refractive index of the heat-treated platinum mirror.¹⁴⁴¹

In 1887, the director of the Berlin Higher School, Nahrwold, investigated the loading of thin films by vapour deposition from a melting pot. His measurements were supplemented by Alfred Berliner and Warburg in Freiburg. In the autumn semester 1886/87 and in March 1888, in Helmholtz's Institute of Physics Nahrwold examined the charging of glowing cathodes made of the platinum, gold, copper, iron, nickel and antimony in the emptied tube. As the source of the current, Nahrwold used Daniel's element, and he emptied his vessel with the Töpler-Hagen pump.

¹⁴⁴¹ Bunshah, 1994, 939. Kundt, 1886, 60–61, 65, 70; Kundt, 1888, 469, 473–474.

He continued the studies of J. Elster and H. Geitel (1887), Berliner (1888) and the secret counsellor W. Siemens, who darkened the glass of the cathode ray tube during 42 hours of glowing in a vacuum of steam of water. In his laboratory, Siemens supplied Nahrwold with 3 cm long hardened Platinum conductors, which did not sputter on glass even after 200 hours. Nahrwold proved that the cathode from platinum is much less dispersed in hydrogen than in the air.¹⁴⁴² None of those German researchers mentioned Edison's Patent of evaporation (1884) and, of course, also not later Edison's Patent of sputtering the plates. In 1907 Soddy continued Nahrwold's research on sublimation in vacuum. Soddy proposed the calcium deposition on the substrate by reducing the remaining pressure in the emptied receiver.¹⁴⁴³ Soddy was Rutherford's student in Montreal, and he collaborated with Ramsay in England since 1902. In 1921, Soddy received the Nobel Prize in chemistry for his research of isotopes.

The German physicist **August Adolf Eduard Eberhard Kundt** was born in Schwerin, 100 km east of Hamburg. In 1886, as a professor of physics in Strasbourg, he published the first discussion, which was entirely dedicated to the vacuum thin films. He worked closely with his student Röntgen, then professors in Würzburg. In Kundt's laboratory, Röntgen met with "cathode rays," which brought him world fame ten years later

11.1.2.7 Condensation and Evaporation in Berlin

Jamin in Paris and Magnus in Berlin investigated the condensation of steam and gases on solid surfaces and showed the importance of adsorbed layers and the connection with catalyst-like chemical processes on the surface. In 1873, Jožef Stefan proved that the rate of evaporation depends on the shape and magnitude of the surface of the liquid, and in some cases even on the shape of the surface. The evaporation takes place differently in the middle than on the edge of the surface. In 1886 Stefan calculated the pressure inside the liquid to prove the connection between the theory of capillary and the theory of evaporation. Sirk continued Stefan's research of the connection

¹⁴⁴² Nahrwold, 1888, 117, 119, 121; Bunshah, 1994, 939.

¹⁴⁴³ Mattox, 2002, 18.

Table 11-1: Results of Wächter's cathode ray research

Property	Sputtered particles from cathode	Sputtered particles from anode
Pressure of gas at which they still are dispersed:	0.007 to 83 mbar	13 to 6000 mbar
Number of dispersed particles is to gas density:	inversely proportional	proportional
the dispersion range		is much longer
the surface which emits them	10,000 times larger	
sputtering is carried out by:	the whole cathode	by points closest to the electrode
form of the electrode is:	less important	important
removal from the non-oxidized surface	yes	/
the direction of sputtering	towards the electrode	perpendicular to the surface
direction of the motion	Random	linear with shadows behind obstacles
magnet curved them like:	paramagnetic substance	diamagnetic substance
particles are eliminated bright	No	yes and no
shape of particles	immeasurable small	measurable
Type of ejection	mechanical	evaporation
heating	helps in sputtering	Unknown
There are carriers of current from electrode	Yes	No
voltage necessary for sputtering		Larger

between surface tension and enthalpy of vaporization in Ljubljana in 1928.

In 1882, as a Helmholtz assistant in Berlin, Hertz investigated the rate of loading of substances in the distillation of metallic mercury in vacuum in two published papers. The evaporation rate is proportional to the difference between the mercury equilibrium pressure at a given temperature and hydrostatic pressure on the surface of the evaporating substance.

Due to the higher conductivity, mercury was more readily prepared for measuring than water. By simultaneous heating and pumping with a mercury pump, a vacuum of less than a millimeter mm Hg was obtained. Herz measured mercury evaporation at nine different pressures for the temperatures between 100 ° C and 200 ° C. Only measurements above 80 ° C were used, where the pressure significantly exceeded the measurement error of 0.02 mm Hg. Hertz found that at 100 ° C condensation was 0.9 mbar per minute.

In addition to Hertz, similar measurements were also published by Helmholtz's doctoral students Ernst Bessel Hagen (Carl G. * 1851 Königsberg; †

1923 Solln by München), Lucien Ira Blake (J. Black, 1854 Massachusetts-1916) and Ronker from the Physical Institute in Berlin in 1883. Measurements of properties of mercury were so interesting because of the Helmholtz theory of friction in fluids and pumps, where it was not possible to avoid traces of mercury in the emptied tubes.¹⁴⁴⁴ The precise measurement of the ratio between the specific heat at constant pressure and the volume of a single-atom mercury was particularly important for Boltzmann's equipartition theorem, which Helmholtz supported. Most of the mercury used was, naturally, flowed from the Carniolan Idrija.

Hertz derived from the results of his experiments the fundamental Hertz-Knudsen equation for the rate of evaporation. In 1909 the Dane Knudsen proved the validity of the cosine law for the evaporation of sulfur, zinc, silver, and SbS₃.¹⁴⁴⁵ On 24 June 1915, he demonstrated that Hertz measured lower velocities than predicted due to impurities on the surface of mercury.

¹⁴⁴⁴ Hittorf, 1883, 721; Jungnickel, McCormach, 1986, 9; Hertz, 1895, 222.

¹⁴⁴⁵ Lafferty, 1998, 222.

In 1913 Langmuir found that the Hertz-Knudsen equation refers to evaporation from free surfaces. At first, as Coolidge's assistant, Langmuir studied the bonds between the atoms in the thin layer of gas on metal conductors that already attracted the research of Davy in 1822 and of Graham in 1866, since this gas deteriorated the vacuum after heating the cathode.¹⁴⁴⁶ Later, Langmuir investigated monomolecular thin films on water and on glass and continued the work of Rayleigh. For his theory of adsorption due to unsaturated valence bonding of atoms on the surface of the layer, Langmuir received the Nobel Prize in Chemistry in 1932.

In 1886 in Berlin, Goldstein discovered canal rays, which later proved to be a stream of positive ions. A decade later he let them through a hole in the cathode onto a gilded glass screen in a discharged tube. The golden coating has "disappeared" due to the burning bombardment of the canal rays.¹⁴⁴⁷ This was the first published description of the sputtering of metals with ion beam: he certainly chose golden coating because of Goldstein's surname.

11.2 Theories of Blistering of Metals

11.2.1 Stark's Theory of the Blistering of Metals

The Germans Berliner (1888), and Stark with Georg Wendt (1912) found the gas adsorption at the discharge causing the macroscopic phenomena of erosion. Wendt just got his PhD in Tübingen and left to research in Aachen as Stark's assistant for seven years. Their assumption was confirmed much later by experiments on gas bubbles that were observed during work on nuclear fuel. Today, the phenomenon is called "blistering."¹⁴⁴⁸

Stark investigated the blistering of metals by the bombardment of positive ions at atomic level. The chemical reactions between the ionic missile and the atom on the surface were correctly estimated as less influential,¹⁴⁴⁹ differently from the opinion of Stark's compatriot Ernst Arnold Kohlschütter (1883-1969) at Mount-Wilson-Observatory of USA in 1912. Stark was one of the leading researchers of

his time. He knew the success of Thomson's work in 1897, where the electrons were considered as particles in classical mechanics. That is why Stark himself described the process of atomizing metals with the law on the conservation of energy, which applied to elastic particles collisions in 1908 and 1909. He was roughly aware of the cross-section of the reaction, as it is now used in particle collisions in accelerators. In this way, Stark could correctly explain the energy dependence of the coefficient of sputtering yield (Y) in the bombardment of a metallic target with protons. Y tells us how many target atoms an average ion breaks out.

Y increases with energy at low ion velocities when a fraction of the energy of the ions is transferred to atoms near the surface of the target. At higher energies, ions penetrate deeper into the target, where most of their energy is collected. Therefore, at higher energies, Y does not grow any more with energy and we observe the saturation. However, the model was supported by experiments using accelerators only in the late 1950s, mostly after Stark passed away. Stark did not exaggerate the confirmation of his ideas, for in the meantime, unfortunately, he leaped into Nazi policies.

In his second model Stark assumed that microscopically small areas were heated to a melting point and evaporated under the influence of ion bombardment. Stark had a collision theory in the bombardment for a different view of the same process and, like Hittorf before him, Stark did not distinguish between sputtering and evaporation. Both Stark approaches treated microscopic quantities. However, the difference between them is like that seen in other areas of physics. The phenomena can be described phenomenologically by macroscopic thermodynamic quantities or by the motion of invisible particles. Similarly, the difference between the description of a group of phenomena and the treatment of individual events was linked by Bohr's special principle of correspondence.

11.2.2 Modern Theory

The experiments have shown that we can explain the blistering and sputtering due to bombardment only with Stark's local evaporation model. The difficulties in the first half of the 20th century mainly acquired from the poor knowledge of the motion of atomic particles with energies below

¹⁴⁴⁶ Hittorf, 1883, 735, 741.

¹⁴⁴⁷ Carazza, Kragh, 1990, 3; Sigmund, 1981 12.

¹⁴⁴⁸ Sigmund, 1981 11.

¹⁴⁴⁹ Stark in 1908, 1909; Šubic, 1862, 107.

1000 eV in solids. Even today's progress in this area is not great, although we could damage the materials with high-energy missiles. Half a century later, Stark's mathematical formalism, was followed by F. Keywell (1952) and D. E. Harrison (1956, 1957, 1960) in modern networks with probability concepts and a cross-section of the reaction that was only in its infancy in Stark's work.¹⁴⁵⁰

The father of **Johannes Stark** was a landowner at Schickenhof in Bavaria. He attended gymnasium in Bayreuth and Regensburg. After 1894 he studied in Munich, where Boltzmann lectured on theoretical physics until that same year 1894, and Röntgen taught experimental physics in Munich after 1899. In Munich, Stark attended lectures in physics, mathematics, chemistry and crystallography and graduated in 1897 with a doctoral dissertation on persistent Newton coils in certain types of cloudy substances, certainly in connection with older Tait's experiments with circuits of smoke. Stark was von Lommel's assistant at the Physics Institute of the University of Munich from 1897 to 1900. Röntgen refused to appoint Stark as his first assistant. So, in 1900, Stark left for an unpaid lecturer in Göttingen, where he researched cathode rays in 1903. In 1906 he became an associate professor at the Hannover Technical College, and in 1909 he was a professor at the Technical College in Aachen. In 1917, he accepted a similar position at the University of Greifswald, and in 1920 he went to the Physics Institute of the University of Würzburg, where he remained until 1922. He measured electrical currents in gases with a spectroscopic analysis to obtain the relationship between structure and spectrum, and chemical valence. In 1919, he received the Nobel Prize for discovering the Doppler effect in the canal rays and spectral line splitting in electric fields. He earned his prize in a private laboratory at Eppenstatt near Traunstein in Upper Bavaria. In the year 1933 Stark became president of the Physical and Technical Institute instead of von Pachen and retained his place until retirement in 1939. At the same time, he was president of the German Research Association. Stark has published over 300 scientific papers. In 1933 he challenged the discovery of Röntgen in favor of Hertz's student Lenard in a kind of revenge for Röntgen animosity thirty-three years earlier. The

Jew Einstein ridiculed the theorizing of experimental physicists Stark, which stimulated Stark and Lenard's Anti-Semitic ideas of German physics. As an activist of the National Socialist Party, Stark was convicted in 1947,¹⁴⁵¹ just like his competitive discoverer of Doppler effect of canal rays, the Italian Fascist Antonino Lo Surdo (1880 Syracuse-1949 Rome) from the Physics institute in Rome. Coincidence or the canal anode rays of Jewish wine-merchant's son Goldstein and Salzburg mason's son Doppler effect politics?

Blistering and sputtering are the results of the expansion of current cascades that occur in collisions of incident ions with solid atoms and in collisions between these atoms. The cascade spreads in all directions. At the point where it reaches the surface of the substance, one or more atoms can leave the surface. In this case, the kinetic energy of the atom must be greater than its binding energy on the surface, which measures about 25 eV. The emergence and expansion of the current cascade can be simulated on computers today.

In 1969, Peter Sigmund published a phenomenological description of the dispersion that agrees well with experimental data. The spatial and energetic properties of the current cascade have been described with the distribution function calculated from the Boltzmann's transport equation. Such a model enables us to describe the general dependence of the sputtering yield Y . We calculate it as a variable, depending on the type of bombarding ions, their energy and the angle of incidence, without much insights into the microscopic details of the expansion of the collision cascade into the substance. The details of the cascades become important especially for the measuring of absolute size of the coefficient of dispersion and quantities, such as the angular and energy spectra of the scattered particles.

11.2.3 Conclusion

Sputtering is a non-thermal mode of evaporation of a substance that was first observed after the metal cathode was bombarded by ions of high energies a century and a half ago. It was among the first discoveries of cathode ray researchers. Initially,

¹⁴⁵⁰ Sigmund, 1981, 13.

¹⁴⁵¹ Harig (Garig), 1936, 301–308; Asimov, 1978, 567.

they were not pleased at the labs, as sputtering reduced the usefulness of cathode ray tube. When, however, the cathode ray tube moved from laboratories to industry in the 20th century, thin films proved to be one of the most useful discoveries. The harmful side-effect began to bring profit, as history happens to make us all happy. Relations turned upside down: arc discharge is only an interesting light phenomenon today, and research of once-annoying phenomenon of thin layer non-thermic Grove's (1852) and Robida's sputtering as well as much faster thermic evaporation of Robida's student Stefan (1871, 1873) had evolved into one of the most profitable modern technologies even if bothered by Stark's (1912) blistering.¹⁴⁵² The metal of the electrodes gradually vaporizes during everyday use of a neon bulb causing blackening at end of a low-pressure mercury-vapor gas-discharge fluorescent lamps known as sputtering and can be observed as the glass capsule darkens by deposition of vaporized metal. The sputtered emission mix forms the dark marks at the lamp ends seen in old lamps. The vaporized material adheres to the glass surrounding the electrodes, causing its darkening and turning black.

¹⁴⁵² Blistering as Slovenian mehurčenje, sputtering as non-thermic slower process (Slovenian: naprševanje tarče po razprševanju), quicker vaporization and evaporation by great heating (Slovenian: naparevanje po intenzivnem segrevanju).

12 New Materials with their Thin Films: Vacuum Metallurgy

12.1 Vacuum Metallurgy

12.1.1 Introduction

Robert Hare was born in Philadelphia, where he also died. He was the son of an English immigrant who founded a large brewery in Philadelphia very early, soon to be actively managed by his son Robert. Thus, Robert Hare's life path was much like the exploration of his younger English contemporary, the brewer Joule. Hare attended a course on Chemistry and Physics in Philadelphia. Even before the age of twenty, he became a member of the Chemical Society, where he published a significant discovery of the blower for hydrogen and oxygen, which he called "hydrostatic" in 1801. Elder Silliman collaborated with Hare in experimenting and called the device a "composite blower". He had it for the first and perhaps the biggest Hare's contribution to science. In June 1803, Hare reported to the American Philosophical Society about the melting of strontium and evaporation of platinum in a newly designed device. With this device the first was obtained in great quantities of molten magnesium, iridium and platinum. Hare's discoveries were used in Drummond's and calcium lamps. Hare invented valves and screws for perfect air sealing of the device. He also made strong batteries even before the Europeans. In 1816 he invented a calorimotor, a battery that produced a lot of heat. In 1820, the device was improved, and it was used three years later for evaporation of molten charcoal. With these batteries, under the leadership of Hare, the first underwater explosion with the Voltaic cell was carried out in 1831. He also excelled as a chemist and invented the procedure for the removal of narcotic properties of opium tincture and for the detection of low concentrations of opium in the solution. In 1818 he became professor of chemistry and natural science of College William and Mary, and in the same year he became a professor of chemistry at the medical department of the University of Pennsylvania and remained there until 1847. He then left his set of devices to

the Smithsonian Institution. Later, like Crookes, he devoted himself to spiritism and lectured about it. In 1806 he received the honorary title of the University of Yale, and in 1816 of Harvard. In 1839 he received the first Rumford Prize for his blower and for improvements to galvanic cells. He was a member of the American Academy of Sciences and Arts, since 1803 he was a member of the American Philosophical Society and an honorary member of the Smithsonian Institution. Only in Silliman's American Journal of Science he has published almost 200 papers. He also published moral papers, often under the pseudonym Eldred Grayson. He wrote many books in which he dealt with both explosive nitrogen and spiritism.

Vacuum metallurgy is the manufacture, design, study and use of metals and alloys under reduced pressure, extending to the ultrahigh vacuum. The use of a vacuum has the following advantages:¹⁴⁵³

- 1) When the pressure of the gases generated during the reaction is lowered, this increases the gradient of the concentration. In this way, the degree of reaction can be increased in many useful cases.
- 2) By diluting the gases, we move the balance against the reactions we want to observe
- 3) The high vacuum obstructs the reactions between the metal vapors and the remaining gases
- 4) The residual gas pressure falls so low that the average free path of the gas molecules becomes large compared to the size of the container and allows greater evaporation
- 5) The elimination of nitrogen and oxygen increases the stability of many substances.

Bellow, we will describe the investigation of melting, degassing, metallurgy of metal evaporation (reduction) in vacuum and some applications of thinning and sputtering of thin films.

¹⁴⁵³ Winkler, Bakish, 1971, 145; Bunshah, 1994, 939–940.

12.1.2 Arc Melting of Metals in Vacuum

During the centuries of development, five methods of melting of metals in vacuum have been established:

- 1) In resistive melting furnaces Rohn used his vacuum as early as 1918, although the process did not apply in the industry
- 2) Vacuum melting in an arc with a meltable or permanent electrode
- 3) Vacuum induction melting in vacuum or in a neutral atmosphere
- 4) Melting with an electron beam
- 5) Growth and cultivation of crystals of reactive metals and alloys in a vacuum.

From these five methods, let's take a closer look at three, since the first one is not really established, and the latter is somewhat not in the context of metal production.

12.1.3 Melting of Metals in a Vacuum

The Vacuum metallurgy was used for the first time in melting with an arc. In 1839 Hare supplied oxygen and hydrogen to the arc through the cathode ray tubes. He melted platinum and produced calcium carbide, phosphorus, graphite and calcium. His invention was used to illuminate the stage in theaters, whose hits in the center of attention are often placed under "limelight" even today.¹⁴⁵⁴

In 1856, William Siemens compiled a "regenerative" melting furnace to replace Bessemer's designs. In 1878 he compiled an electric metal melting furnace and patented it in Britain next year.¹⁴⁵⁵

The Slovenian ancestors, the descendants of renowned ironworks, read about Siemens's "electric swimmers": "On the left we see the vessel used for melting. To its bottom, a positive current is kept with a stick of platinum or charcoal. The vessel is squeezed with pieces of metal, which we intend to dissolve. From the top extends into the pot the

vertical carbon rod, which is with wire A in relation to the negative pole. From the beginning, this stick touches the metal fragments, but when the rod begins to circulate, the rod with an automatic device is raised a few millimeters to create a flamed arc that dissolves metal fragments. If the metal is lowered by melting, the carbon rod is equally lowered by the self-regulation so that the dissolving flame arc does not stop (Figure 12-1).

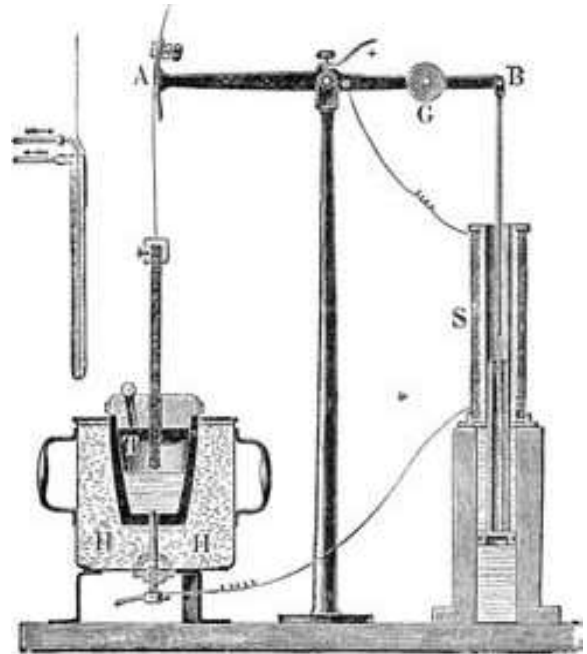

Figure 12-1: Electric smelting of Siemens¹⁴⁵⁶

Siemens was, of course, among the inventors of the operation of a new melting furnace. He tried to sell it well, therefore he displayed its facilities in public. He placed his pound of shavings in a melting pot and liquefied it with a current of 70 A in 13 minutes so that he could pour it in. In the hot melting pot, the same amount of substance could be melted after 8 minutes.

William Siemens' arc furnace was used for melting and fusing smaller amounts of metal at higher temperatures. Even in the production of larger quantities of iron, it was more useful than a furnace which he developed simultaneously with his younger brother Friedrich Siemens. In 1864, the father and son, the Frenchmen Émile Martin (1794 Soissons -1871 Fourchambault) and Pierre-Émile Martin (1824 Bourges-1915 Fourchambault), commissioned its use in industry as Siemens-Martin's furnace.

¹⁴⁵⁴ Bowers, 1998, 57–58.

¹⁴⁵⁵ Bunshah, 1994, 938.

¹⁴⁵⁶ Šubic, 1897, 201.

In 1906, the Frenchmen Moissan received the Nobel Prize for chemical research in a melting furnace heated by the arc discharge formed in 1892. By lowering the electric current between graphite, the electrodes reached temperatures up to 3500 ° C. In 1893 he first acquired artificial diamonds and hydrated tantalum, which he mistakenly had for pure metal. Three years later, he investigated uranium and prepared some compounds for H. Becquerel's pioneering work on radioactivity.¹⁴⁵⁷

German **Werner von Bolton** was the son of the manager of the Siemens copper mine in Tbilisi (Tiflis). In his younger years he came to Berlin, where he was supported by Werner Siemens. He studied in Charlottenburg-Berlin and Leipzig, where he received his PhD at Ostwald's class in 1895. Already during his studies, he published a discussion about copper and about the bulb. Between 1896 and 1902 he developed tantalum bulbs in the Siemens & Halske Bohneshof laboratory in Berlin-Moabit and assisted William's nephew, Wilhelm von Siemens. At the time it was founded in 1902, he became head of the Siemens Laboratory of Photoelectric Laboratory and Halske AG in Berlin, where he also died in 1912.

Von Bolton was the first to eliminate 99.5% pure tantalum, of the ore that had been known in the compounds for centuries¹⁴⁵⁸. He composed a melting furnace on an arc with water-cooled nickel electrodes. He discharged the vessel and prevented the oxygen supply. With von Bolton's device, molten metal was later deposited on glass of cathode ray tubes.¹⁴⁵⁹

The experiments showed that pure metals have many different properties than ordinary metals in alloys. Von Bolton was primarily looking for the pure metals as charcoal substitutes in Edison's bulb: "The technical goal of my research was to find a metal suitable for an incandescent lamp in an electric bulb, that is a metal with a melting point above 2000 ° C, which would not too sputtered by electricity and could be easily formed into a wire ..." Among niobium, vanadium and others Bolton chose the tantalum. His pure tantalum was obtained

by electrolytic reduction from tetroxide, and by melting of the tobacco dust in the flame of the electric arc. By reduction, he heated the tantalum oxide in a emptied receiver and thus extracted gas oxygen. From a brown oxide a gray metal like a platinum could be minted and formed. In 1905 and 1906 he liquified the tantalum by arc of a melting electrode with a layer of charcoal, whose elasticity was reduced by the addition of wax. He melted in a vacuum with traces of argon and got about a ton of tantalum. In determining the density and other properties of the tantalum he was assisted by a young doctor Pirani, a later pioneer of vacuum technique.¹⁴⁶⁰ Due to the small specific electrical resistance of the tantalum, von Bolton had some problems with the use of a bulb with a 0.05 mm thick and 650 mm long wire. He measured an average lifetime of 1000 to 1500 hours at 1.3 W / cd consumption of several hundred tantalum bulbs; at that time, a very good achievement.

In 1907, von Bolton carried out similar experiments with niobium, which he also directly reduced in alternating-current electrolysis in vacuum or by arc glowing in a vacuum. However, the niobium lamps lit only 8 to 14 hours, so they did not seem particularly promising. The pure niobium was much more difficult to obtain than the tantalum, as it had to be vacuumed up to 200 times.

As early as January 1905, Siemens & Halske began to sell von Bolton's tantalum bulbs. In 1914 they sold 50 million pieces; later they were expelled from the market by GE's tungsten light bulbs designed after Coolidge's patent from 1909.

The use of the simple von Bolton process has grown considerably half of a century later without the physical background being fully explained. The methods were no longer used so much to produce tantalum, but remained indispensable for production of zirconium and hafnium. High vacuum sintering is still suitable today for production of pure grain tantalum, but not for niobium and its alloys. In the production of ductile tungsten tantalum, the "Coolidge process" of sintering with the direct passage of the electric current prevailed (Figure 12-2).¹⁴⁶¹

At the time of von Bolton's experiments, the German engineer Otto Archibald Simpson designed

¹⁴⁵⁷ Šubic, 1897, 203; Hurd, 1964, 367.

¹⁴⁵⁸ Siemens, 1957, 1: 287–289, 2: 255; Fox, Guagnini, 1999, 270.

¹⁴⁵⁹ Siemens, 1957, 1: 209–210, 288, 2: 255; Šubic, 1897, 201.

¹⁴⁶⁰ Bolton, 1905, 45, 48, 51.

¹⁴⁶¹ Winkler, 1971, 171, 681–682, 685.

and built a melting furnace with an arc to liquify tantalum for Siemens & Halske of Charlottenburg between 1903 and 1913.¹⁴⁶² The tantalum was used in lamps and for surgical devices. In 1909, Ludwig Weiss of inorganic lab of Munich Polytechnic (anorganische Laboratorium der technische Hochschule München) and Anton Stimmelmayer (Stimmelmayer, 1884 Dingolfing in Lower Bavaria-1963) for his published Ph.D. defended in the royal Munich Polytechnic (Technische Hochschule zu Munchen) melted tungsten in the atmosphere of hydrogen, ammonia, nitrogen and in a vacuum. Four years later in Strasbourg chemistry lab (Chemisches Institut der Universität Straßburg) Edgar Wedekind (1870 Altona by Hamburg-1938 Erfurt) used fusible electrodes of the arc for the melting of volatile zirconium borides, other borides and similar compounds in a vacuum.

DAS NIOB, SEINE DARSTELLUNG UND SEINE EIGENSCHAFTEN.
 Von Dr. Werner von Bolton.

I. Einleitung.
 Im Jahre 1801 entdeckte der amerikanische Chemiker Hatchett in einem Mineral Nordamerikas, dem Columbit von Massachusetts, eine eigentümliche Säure, die er Columbinsäure nannte. Aber erst Heinrich Rose erkannte durch zürliges, unabhängiges Studium die wahre Natur dieser Säure, die er häufig mit Tantal säure vergesellschaftet fand, und die er Niob säure nannte. Im Verlaufe seiner diesbezüglichen klassischen Arbeiten glaubte er noch ein Element im Niob gefunden zu haben, das er Pelopium nannte, welches sich aber schließlich auch als Niob erwies. Auch das Dianium Kobalts und das Plutonium Hermanns, sowie das Neptunium¹⁾ derselben Forscher erwiesen sich als Niob, bzw. als Gemische von Niob mit Titan.
 Das Niob kommt in der Natur meistens vergesellschaftet mit Tantal vor, und zwar überwiegend gewöhnlich der Niobgehalt in solchen Mineralien denjenigen von Tantal ganz wesentlich, namentlich in den Columbiten, es gibt aber auch eine grosse Reihe von Mineralien, die niobhaltig und dabei tantalfrei sind, wie z. B. Euxenit, Polykras, Pyrochlor u. s. w. Natürlich fehlte es nicht an Bemühungen, aus der Niob säure das Niobmetall zu isolieren, und Blomstrand²⁾ glaubte es, auch erreicht zu haben, indem er Niobchlorid mit Wasserstoff im glühenden Rohr reduzierte, wobei er einen metallgrauen, spiegelnden Ueberzug erhielt. Koscoe³⁾ verfuhr in gleicher Weise mit Pentachlorid dampf und erhitzte den ent-

standenen Niederschlag nochmals heftig in Wasserstoff, wodurch er ein Produkt erhielt, das angeblich nur 0,27% H, etwas Chlorid und Oxyd enthielt. Wir werden aber im Verlaufe dieser Arbeit sehen, dass es auf diese Weise unmöglich ist, Niobmetall zu erhalten. Ebenso wenig gelingt seine Isolierung durch Reduktion des Oxydchlorids mit Natrium, wie es H. Rose und Hermann versucht hatten, die auf diesem Wege nur Nioboxyd erhielten⁴⁾, einen metallisch aussehenden, den elektrischen Strom gut leitenden Körper. Goldschmidt⁵⁾, wofür sein bekanntes aluminothermisches Reduktionsverfahren auch zur Reduktion der Niob säure an, erhielt aber dabei eine Legierung von Niob mit Aluminium⁶⁾. Weiss und Aichele reduzierten verschiedene Metalloxyde mit Hilfe des sogen. Mischmetalls, einer Legierung der Cermetalle, und erhielten bei der Reduktion von Niobpentoxyd einen Regulus, den sie für reines Niob halten⁷⁾; die angegebenen physikalischen Eigenschaften des erhaltenen Materials stimmen aber nicht mit denen des reinen Metalles überein, wie weiter unten gezeigt wird, so dass auch das Weiss-Aichele'sche Produkt kein reines Niob sein kann.

Eine Niobschmelze erhielt H. Moissan⁸⁾ durch Erhitzen eines Gemisches von Niobpentoxyd mit Zuckerkohle im elektrischen Ofen bei 600 Amp. und 50 Volt. Er erhielt auf diese Weise eine geschmolzene Masse mit metallischem Bruch, die sehr hart war, Glas und Quarz ritzte und oberhalb 1800° schmolz. Die analytische Untersuchung ergab aber einen chemisch gebundenen

12.1.4 Vacuum Induction Melting of Metals

In 1890, Lake described the melting of metal in a circular tube. The metal was poured into the models by tilting the entire melting furnace. That same year in USA, Edward Allen Colby patented the foundations of modern vacuum induction melting in a melting furnace from a emptied receiver. The low-frequency induction coil was connected to a model connected over the opening. In 1904, William C. Arsem (P., * 1881 Massachusetts) at GE headquarters in Schenectady designed a vacuum resistive metal cleaning agent by evaporating impurities, promoting metallurgical gas reactions, and protecting reactive metals against pollution. He developed a vacuum water-cooled metal degassing vessel, a spiral graphite heater and a graphite screen. His devices are still used to analyze gases after melting in a vacuum. Three years later he developed various separation metallurgical operations at temperatures above 1500 ° C.¹⁴⁶³



Figure 12-3: Production of thin films at the W.C. Heraeus in the years 1940-1944

Figure 12-2: The introductory page of von Bolton's discussion of niobium (1907).

In 1923 Roy W. Moore of Schenectady GE melted uranium at a pressure of 10 µm Hg in argon gas. He picked up a tungsten electrode covered with uranium. Twelve years after him, In November 23, 1935 in his electric arc welding apparatus designed for M.W. Kellogg co., Robert K. Hopkins used a cold crucible and a melting electrode to smelt the metal and to purify it with drops that went through the melt flow; this was the precursor to the modern electrical slag elimination process.

In the next decade Rohn began to develop commercial vacuum melting in large melting furnaces. In 1917, he melted nickel alloys with Joule's heat and patented the process next year. In 1921, he used a low-frequency vacuum smelting furnace with a mass of 300 kg at Heraeus, which until then was known primarily for production of quartz lanterns. Three years later, he described the production of pure chromium by reducing oxide by hydrogen. In 1928, he used a 4-tonne 350 kW power source for casting 2-ton ingots. He produced thermocouple and alloys for resistant heating. In

¹⁴⁶² Bolton, 1905, 48.

¹⁴⁶³ Bunshah, 1994, 938.

1929, Rohn developed a large melting device for melting metal at a pressure of 10 to 50 mm Hg. Adding iron oxide or chrome ore reduced the percentage of carbon in molten ferrochrome from 1% or 3% to 0.04%.¹⁴⁶⁴

Between the two world wars, the Germans needed solid metals withstanding very high temperatures, of course, especially for turbines of aircraft engines for their new massacres (Figure 12-3). In 1932, Rohn began producing metal, especially useful for thin conductors. However, poor vacuum systems prolonged the pumping to 14 or 15 hours, and the use of the Rohn's process was hampered by low demand in the economy.

During the same Rohn's era, Trygve Dewey Yensen (1884-1950 Pittsburgh) tested at his workshop the smelting of magnetic materials in Westinghouse's lab of East Pittsburgh in the United States. However, industrial devices did not develop before the Second World War. The development was accelerated by the nuclear industry using titanium in the early 1950s, and later by using Ni-alloys for turbine blades.¹⁴⁶⁵ The British Telegraph Construction and Maintenance Co. began to produce electric and magnetic alloys in the 1930s.

Father **Wilhelm Julius Paul Rohn** was the rector of the College of Dresden, and the uncle was the director of the Chemists' Association in Meinheim. Between 1905 and 1911 Rohn studied in Leipzig and Strasbourg, where he was a student of Braun, an inventor of a cathode-ray tube. In 1912, Rohn investigated anomalous dispersion and fluorescence. He continued the work with Braun, and in 1922 and 1923 he received a German patent for the improvement of the vacuum tube. He had been experimenting in physics since 1913, and in 1923 he became the head of Heraeus.

12.1.5 Metal Melting with an Electron Beam in a Vacuum

The electrons in the material itself produce heat for melting and segregation. The melting by an electron beam causes local temperature rise by electron collisions, which was already observed by Grove during the rapid oxidation of a positively charged

metal plate on which the electrons were directed from the point of the platinum conductor in 1852. He also melted iron, "which was particularly instructive: the iron evaporated in the Voltaic arc, both in a nitrogen container and in a vacuum. The container was covered with a perceptible stain ... Thus, we indeed distil the iron, which melts by ordinary tools only at very high temperatures (Figure 12-4)."¹⁴⁶⁶

In 1879, Crookes heated platinum to a white glow and melted it during a "cathode ray" bombardment. At the focus of the cathode, in the form of a convex mirror, he melted the platinum and iridium alloy. The melting of target in the vacuum tube after electron bombardment was an experimental inconvenience, from which the modern processes of melting of metals and bombardment of metal with electrons have been developed;¹⁴⁶⁷ the same happened to the initially harmful thin films at the wall of the cathode ray tubes.



Figure 12-4 : The title page of the German translation of William Robert Grove's highly acclaimed book (1811; † 1896) *Die Verwandtschaft der Naturkräfte*, printed in Braunschweig in 1871.

¹⁴⁶⁴ Winkler, 1971, 171.

¹⁴⁶⁵ Bunshah, 1994, 938; Winkler, Bakish, 1971, VI, 517.

¹⁴⁶⁶ Grove, 1871, 84.

¹⁴⁶⁷ Rosenberger, 1890, 780.

On 17. 9. 1907 in the United States, Marcello von Pirani patented the melting of tantalum and other metals in electron beam. The process contained most of the basic ideas of the modern industry and even the later Temescal electronic gun system from the 1950s. In May 1908 in Scientific American, Charles Algernon Parsons and Alan Archibald Campbell Swinton described their use of electrons to investigate the conversion of diamond into graphite. Early electron beam melts were also contributed by E. Tiede in 1913 in Germany, F. Trombe in 1934 in France, and Ralph Hultgreen and M. H. Pakkala in 1940 at Graduate School of Engineering, Harvard University, Cambridge, Massachusetts in the United States. Nevertheless, the process did not become useful, since there were no major needs in industry before 1954; then, riding on the new user's wind, the researchers of Berkeley's electronics accelerator were united in their new firm Temescal. In 1938 von Adrenne was the first to use a jet of electrons for a working tool. In the mid-1950s, electrons were used for welding, which the Frenchman Jacques-André Stohr of Commissariat à l'énergie Atomique and W. L. Weyman described in 1958 for the needs of the nuclear industry. In 1953, Karl-Heinz Steigerwald (1920 Koblenz-2001) began cutting with an electronic beam for AEG Research Institute in Mosbach, Baden, later for Zeiss and for his own firm. These discoveries gradually developed into various forms of heat treatment of metals in a vacuum. For the first time and for a long time, the only book dedicated entirely to melting electron beam was issued in 1965 in the Soviet Union, where melting systems like von Ardenne's electronic rifles were developed in Moscow.¹⁴⁶⁸

12.1.6 *Degassing of Metals in a Vacuum*

The degassing process is used as the name of the process due to historical circumstances, although today we know that the steel contains most of the gas molecules in the form of compounds. Similarly, the game of outdated words is kept in the setting sun, the shining of the moon, positive electricity at points with a deficit of electrons and similar expressions, which have already become too much domesticated to allow any altering by new scientific discoveries.

12.1.7 *The Theory of Absorption and Degassing of Metals*

The professor of chemistry in Brussels, Louyet, studied the flow of hydrogen from the capillary through 1 mm of distant leaves from gold, silver and other substances already in 1848. Few months later poor Louyet died because of his extensive experimenting with the toxic fluorine even if he used his protective mask. Two decades later, the Parisian professor Sainte-Claire Deville from École Normale Supérieure and his former Ph.D. student Troost, measured the permeability of metals for gas. The cast iron furnace, which was used in Paris for heating military guardhouses, was wrapped in iron mantle and placed in a built cavity where they could warm their furnace up to a dark or bright red grill. They exhausted the air and explored the remaining hydrogen and CO₂. By 1000 l of air they got a residual of 0.23 to 1.07 l of hydrogen and 0.22 to 0.71 l of CO₂. In the second experiment, it turned out that hydrogen from a closed cast iron tube, heated in the furnace shortly, was completely expanded into a vacuum. Later, they measured the permeability of metals for gases: they tried to figure out if the gas flows through the pores of metal or was absorbed on one side of the metal sheet and eliminated on the other.

Mining engineer **Louis Paul Cailletet** worked as a young man in his father's blast furnace at Chatillon-sur-Seine. In the 1870s, he investigated the properties of real gases, and he liquified the oxygen for the first time in December 1877. Since he was just elected as a correspondent member of the academy at that time, he delayed publication of his discovery for a few weeks, so he was nearly overtaken by Pictet in Geneva in a case of simultaneous discoveries as problem was appealing and the tools for discovery were at hand. Priority was given to Cailletet's letter in which he disclosed his discovery to his friend Sainte-Claire Deville in a timely manner. In 1878, Cailletet received the Davy Medal, in 1884 he was elected as a regular member of the Academy in Paris, and in 1889 he became a Legion of Honor Officer.

Cailletet's experiments supported the first assumption in 1868. He used a thin iron sheet with a cavity in the middle. Through the thin copper

¹⁴⁶⁸ Winkler, Bakish, 1971, 593–594, 613–614.

tube, he translated gas from the cavity. When the ferrous container was placed in H_2SO_4 or HCl , the boiling bubbles of pure hydrogen soon began to emerge from the copper tube. Cailletet explained that gas bubbles develop in course of acid action on iron. Then acid prevents their outflow but they pass through the iron inwards. From here it follows that iron is also transient for gas at normal temperatures; gas extraction is proportional to the surface of the pig iron. He believed that the gas flow was not affected by the special force, but the gas freely breaks through the pores of iron.

In 1866, Graham confirmed the older results of Sainte-Claire Deville and Troost that hydrogen diffused through the heated platinum cathode ray tube. By the palladium cathode ray tube, he separated hydrogen from a mixture of gases. Graham measured that palladium absorbs about 900 times the greater volume of hydrogen compared to its own. In experiments, Graham used only a simple vacuum pump and a tube filled with the mercury.¹⁴⁶⁹

The Scotsman **Thomas Graham** studied in Glasgow. Between 1830 and 1837 he was professor of chemistry there. In 1831, he published a law called by his name. He stated that diffusion of gas is inversely proportional to the square root of the mass of its molecules. In 1837 he became a professor of chemistry at the University College in London. In 1854 he took over the former Newton's position as head of the state treasury as the last Master of the mint, but, unlike Newton, he continued to publish his scientific research without much alchemy involved.

Graham disliked the pores in the metal. Graham opposed Cailletet's assumptions and explained the experimental results by absorbed gases in metals. He argued that the transition of hydrogen through a thin iron sheet at lower temperatures from Cailletet's experiment can be done by the acid itself. In any case, hydrogen was absorbed in iron at a considerable level at these temperatures. At very high temperatures, soon above the red beam, hydrogen was eliminated. Similarly, according to Graham, happens in platinum and palladium, which absorb hydrogen the most among all metals. At

normal temperature below 100°C in the vacuum, palladium does not let hydrogen through: "Therefore, I believe that the transfer of hydrogen through the metal always follows the gradient of concentration or absorption of gas. I am justifiably assuming that the speed of the passage is not proportional to the volume of the absorbed gas, otherwise palladium would be much more permeable at lower than at higher temperatures. At temperature of 267°C the palladium plates eliminated all their hydrogen which they contained at lower temperatures but remained permeable. The palladium permeability increases at higher temperatures when the quantity of hydrogen retained in the metal can no longer be observed. I believe that the hydrogen is still there, but a kind of rapid hardening happens to it in the metal."¹⁴⁷⁰

The palladium gave away all its hydrogen at a temperature of 267°C but remains permeable for the same gas. This to some extent opposed to Graham's view, since it is difficult to believe that the metal at the temperature at which all hydrogen is already released does still absorb the same gas. According to Graham, the rubber, which at all temperatures eliminates all absorbed hydrogen, is still more permeable for hydrogen than CO_2 . Graham's interpretation of the experiments did not support the free flow of gas through the pore of the metal. Graham's transfer of hydrogen and CO_2 through the metal should be like the diffusion of the liquid through the semi-permeable membrane, while at the same time there will be an attraction and reflection of the liquid.

Graham did not have gas absorption in a metal for normal mechanical motion, but for some special kind of chemical coupling. Hydrogen absorption changes the density, strength, electrical conductivity and other physical properties of palladium. The absorbed hydrogen does not behave like plain gas. That is why Graham treated hydrogen absorbed in palladium as a palladium alloy with another metal, which was initially well received between physicists and chemists. Today, such phenomena are called chemisorption and the permeabilities of organic membranes provide one of the clues into the secrets of life processes.

In 1820 the first quantitative measurements of oxygen solubility in silver at normal pressures were already published by French Gay-Lussac at

¹⁴⁶⁹ Bunshah, 1994, 936, 938; Grove, 1871, 132.

¹⁴⁷⁰ Rosenberger, 1890, 622–625.

temperatures up to 1125 ° C. A century later, Sieverts placed metal in a quartz cylinder (at higher temperatures he preferred porcelain) and connected it with a burette, like Hans Hugo Christian Bunte's (* 1848 Wunsiedel; † 1925 Karlsruhe) burette designed for gas analysis in 1887. With Töpler pump Sieverts first emptied the cylinder and then released the measured quantity of gas through the burette. Sieverts measured the temperature with a thermocouple and determined the pressure by the mercury level difference in the U-tube.

In 1928 at the main assembly of the German Metallurgical Society in Dortmund, after numerous experiments Sieverts and his students announced that the mass of the dissolved gas molecules in the metal is proportional to the square root from the partial pressure of the gas at a constant temperature. Similar issues, closely related to the kinetic theory of gases, have been discussed since Graham's time. That's why some opposed Sieverts' results. Among them, the Berliner professor M. Pirani assured that, in his decade long experiments with palladium and iron, the solubility of the gas was never related to the rate of gas diffusion in the metal. Pirani was of course a respectable man; despite of this, Rohn and others supported Sieverts' correct theory (Fig. 12-5).¹⁴⁷¹

12.1.8 *Degassing of (Liquid) Steel in a Vacuum*

On 27 July 1865, Bessemer described the use of models in an empty space into which the liquid steel or iron was applied using atmospheric pressure in his patent for the "extraction of iron and steel without burning materials".

Henry Bessemer was a descendant of French emigrant of English descent Anthony who returned to England scarred by the Revolution at the end of the 18th century. Anthony Bessemer used to be a member of Parisian academy of sciences in 1784; his forced migration repeated the loss of French intellectual potential during the exodus of Huguenots a century earlier. In 1855 Henry Bessemer compiled his first converter. However, the publication of the invention did not bring success to him in 1856, as he needed iron ore without phosphorus, which was mined primarily in Sweden. After 1860, he enriched himself with the Sheffield Steelworks. The low price of steel, obtained through new processes, triggered the rapid production growth. Bessemer worked as an engineer in London, where he became a fellow of the RS in 1879. A century earlier on 14 December 1687 the same Royal society elected the Carniolan Valvasor as a fellow. Like Bessemer, Valvasor reported to London about his invention of a special procedure for casting thin metal surfaces on August 29, 1686. Valvasor used it to make metallic statues while Henry Bessemer preferred iron.

¹⁴⁷¹ Rosenberger, 1890, 626.

Adolf Ferdinand Sieverts was born in Jena, and after 1894 studied in Dresden, Leipzig and Göttingen, where he received his Ph.D. from Wallach in 1898. In 1910, Wallach got his Nobel Prize in chemistry for his research of terpenes. Between 1907 and 1919, Sieverts taught in Leipzig. In 1922, he became a professor of inorganic and analytical chemistry in Frankfurt, on Main, and since 1927 he was a professor and director of a chemical laboratory at the University of Jena.



Figure 12-5: The title plate of the Sieverts discussion (Sieverts, Die Aufnahme von Gasen durch Metall, Z.Metallk., 21 (1929) 37, 38)

The American Robert H. Gordon patented modeling of ingots in a vacuum in 1883. In 1897 in Germany E. May patented an device for simultaneous casting of several models in an emptied receiverl (Figure 12-7). In 1885, Compressed Steel Comp. received a German patent for a different casting system that excluded the atmosphere and could be used for production of steel.

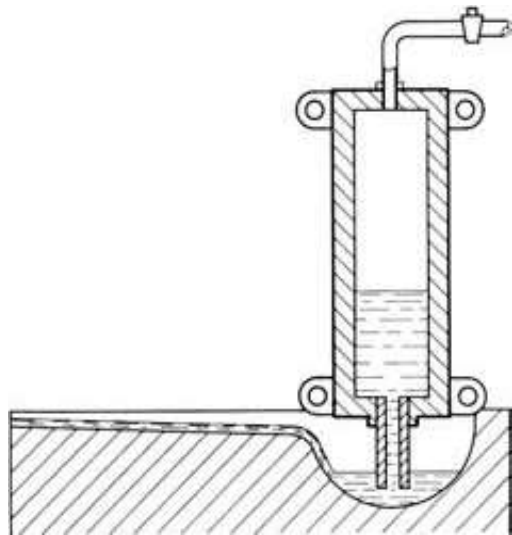

Figure 12-6: Bessmer's proposal for steel casting from 1865¹⁴⁷²

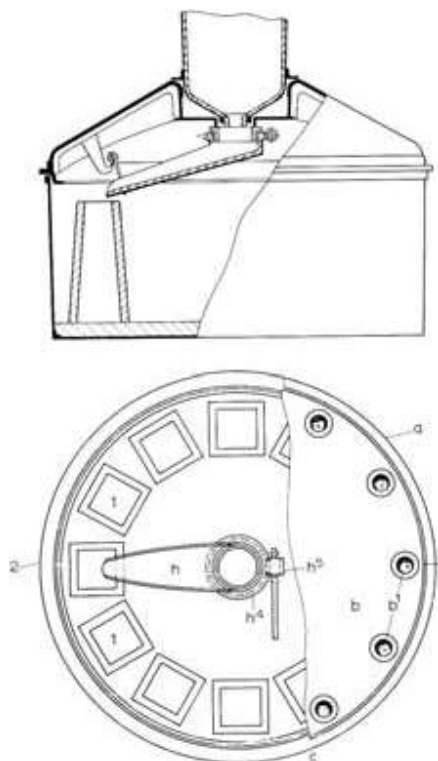

Figure 12-7: May's proposal for steel casting from 1897¹⁴⁷³

¹⁴⁷² Winkler, Bakish, 1971, 338.

¹⁴⁷³ Winkler, Bakish, 1971, 339.

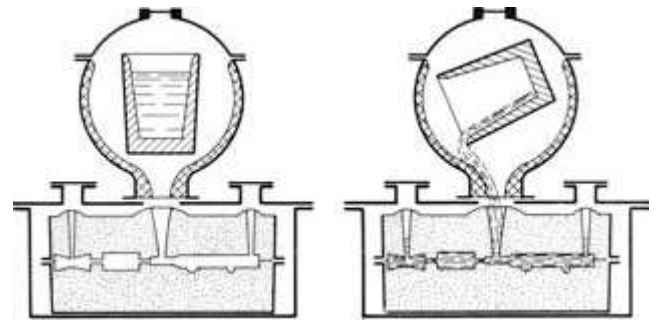

Figure 12-8: Simpson's proposal for steel casting issued in 1892.¹⁴⁷⁴

At the end of the 19th century, the designers began to place melting units and models in an emptied receiver. In 1889, E. Taussig obtained a German patent for a single-phase electric furnace with a mold in an emptied receiver. He obtained additional English and German patents in 1893. In 1892, W. S. Simpson patented the frying pan instead of the melting furnace, which he placed together with the mold in his emptied receiver (Figure 12-8).

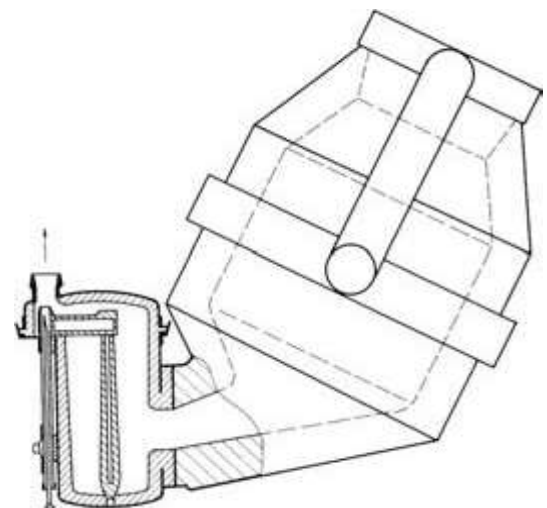

Figure 12-9: Tholander's proposal for steel casting from 1881.¹⁴⁷⁵

The researchers repeatedly patented the degassing during the flow of melt into the frying pan. On 30. 5. 1874, the Swede Henrik Evald Tholander (Thålander, 1847 Stockholm-1910 Stockholm) obtained his Ph. D. in Uppsala and he met later famous mathematician Henri Poincaré on 22. 8. 1878. As an experienced Swedish mine and metallurgy expert, Tholander patented the production of Bessemer's steel ingots in Germany in

¹⁴⁷⁴ Winkler, Bakish, 1971, 341; Wilhelm Borchers, *Design & Construction of Electric Furnaces*, Watchmaker Publishing, 2005, 28-30.

¹⁴⁷⁵ Winkler, Bakish, 1971, 341.

1881. He proposed a coupling connection of the vessel in exhausted container with the converter mold through the vacuum seals. The steel in the melting pot would degas during the overflow. At the end of the process, the melting vessel and "Bessemer's" would be separated, and steel was casted in the usual way (Figure 12-9).

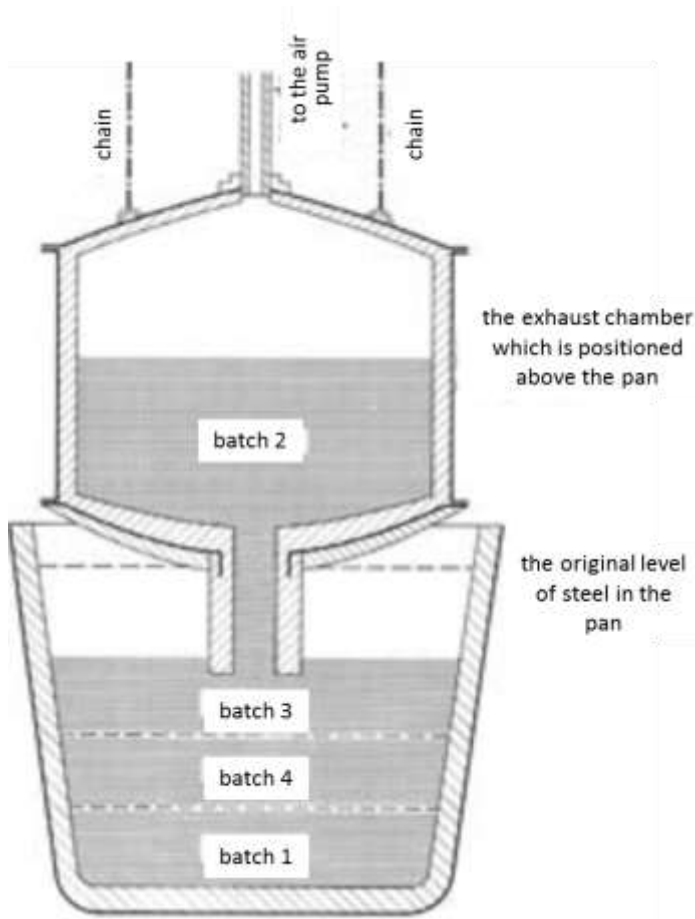

Figure 12-10: Aitken's proposal for degassing in 1882¹⁴⁷⁶

Technical problems prevented the implementation of these interesting ideas and, at the end of the 19th century, for a special vacuum degassing unit with a casting pit. The simplest way to move the casting pit into the vacuum container after streaming and then degassing was established in 1882. A different patent from "Dellwik-Fliescher Wassergas-Gesellschaft" of Frankfurt was issued in Germany just before World War I to install a superheated liquid steam steel in superheated vacuum container. Due to the increased efficiency and better degassing, the vacuum process could be extended to several hours. Emil Fleischer (* 1843 Schwedt / Oder, † 1928) contributed to the titration methodology and gas decomposition. He provided a

¹⁴⁷⁶ Winkler, Bakish, 1971, 343.

scientific justification for Karl Dellwik-Fleischer's method for production of water gas as mixture of carbon monoxide and hydrogen. In Frankfurt, they founded the Dellwik-Fleischer-Wassergasgesellschaft mbH.

In 1874, 1879 and 1882, Parsons, Russel Aitken and Jensen designed a vacuum treatment of molten steel. In Germany, Aitken patented the degassing of steam and the pumping of molten steel through a tap into an emptied receiver due to the difficulties in removing gas from molten metal. He used a special container with an insulating layer for the refraction of light, and the suction hose was placed on the bottom. The container was immersed in the frying pans during alternating suction and injection of the air. Part of the melt could be sucked into a special container to gradually decompose the solution (Figure 12-10). After his patents granted all over Europe, Aitken filed US patent No. 310,012 on December 30, 1884.

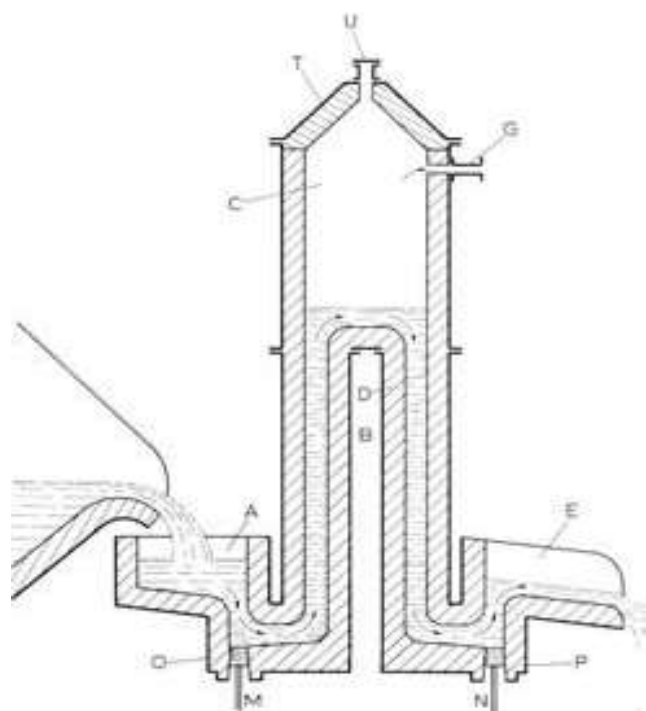

Figure 12-11: Wainwright's proposal from 1898¹⁴⁷⁷

On 28 January 1898 in the United Kingdom and US no 11,737 granted April 25, 1899 the Chicago civil engineer vivid antagonist of second law of thermodynamics in Parisian academician Émile Amagat's (1841 Saint-Satur-1915 Saint-Satur) sense Jacob Tripler Wainwright (* 1854) patented the improvement of the Aitken method using two inlet pipes with liquid steel, which was the basis of

¹⁴⁷⁷ Winkler, Bakish, 1971, 344.

the circular process. The steel flowed through the emptied receiver continuously. Each feed pipe had a stopper, like the siphon, in the lower part. The steel was immersed in one of them to leave the degassing container later. The steel in the emptied receiver was pushed by a hydrostatic pressure due to the difference in the levels between the two baths in the stoppers shaped like siphons (Figure 12-11).¹⁴⁷⁸

For small heat losses, an emptied receiver in a gas furnace was heated before degassing. The president of Gordon Battelle's (1883-1923) Memorial Institute in Columbus, Ohio Dr. Clyde E. Williams filled his US patent on the same foundations on March 23, 1931, while his flow of steel was increased by injection of the gas into the feed pipe. Like Aitken, C. E. Williams could re-drain the fumed iron into the original lime pan. Williams has presented concentrically placed inlet and outlet pipes. In the 1920s, many proposals for improving Wainwright's procedure were published. On November 12, 1923, J. U. Betterton patented a permanently attached emptied receiver in the melting furnace. A similar patent was received by Waldron a quarter of a century later in the United States and Britain with additional proposals for induction heating in an emptied receiver (Figure 12-12).

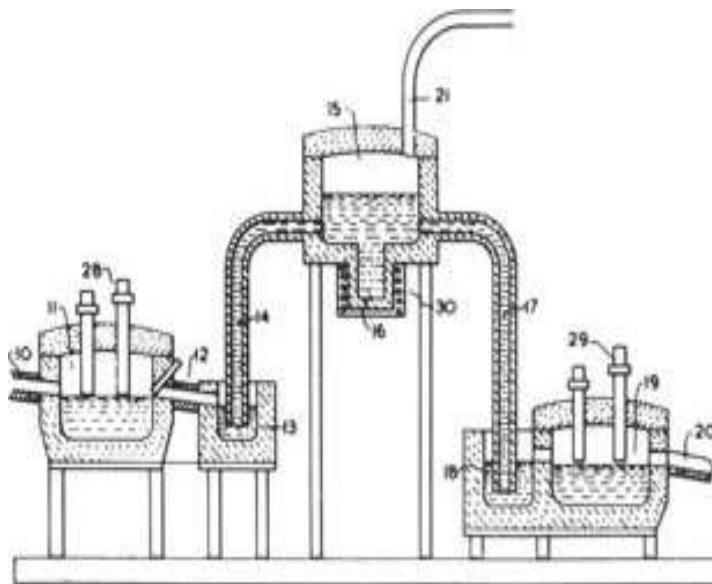

Figure 12-12: Waldron's proposal in 1949¹⁴⁷⁹

L. Maré patented newly invented approaches to degassing in the US and Sweden on August 20, 1938. He submitted a vacuum degassing of the

molten metal stream during casting or pouring. The flow of molten metal was directed to the intermediate lime pan associated with the emptied receiver. The second casting pan was placed in the same vacuum tank for receiving a stream of degassed steel. Following the laboratory experiments published between 1912 and 1953, such a procedure was chosen to begin the extensive use of degassing in industry, which was developed primarily by Bochumer Vereins in Germany and in U.S. Steel between 1954 and 1956. As the first vacuum process in the steel industry, it has accelerated further exploration of steel degassing. So far, about twenty different melting methods have been developed and tested for their use in industry. Of course, only some of them were used in the steel production: the casting pan with steel in an emptied receiver, degassing of steel current, circulating degassing and degassing during casting or after casting.¹⁴⁸⁰

12.1.9 Separation Metallurgy (Reduction)

In 1882, after his extensive travels to Egypt and India, Dumas's student Demarçay described the extreme volatility of many metals in a vacuum. In 1905 Berthelot's collaborator the professor of chemistry in Nancy Guntz dissolved barium hydride in a steel vacuumed vessel at 900 ° C, heated it by 30 ° C and distilled the barium to 99.6% purity. In 1913 the member of AR Matignon reduced barium oxide with silicon or ferrosilicon, and MgO with aluminium at 1200 ° C. The reduced magnesium was sublimated and could be collected. Eight years later, Matignon used CaC₂ to reduce MgCl₂ at 1200 ° C.¹⁴⁸¹

The use of a vacuum in separation metallurgy was investigated by DeBoer, J. D. Fast, and Van Arkel at the Philips National Laboratory in Eindhoven. In 1925, many low pressure high-temperature dissociation reactions were described using a known technique of "wire drawing" and thermal decomposition. Ten years later, DeBoer successfully tested the semiconductors.¹⁴⁸²

W. J. Kroll developed a technique for vacuum distillation and vacuum thermal reduction for several metals. In 1939 he updated von Bolton-Simpson's melting furnace for reactive metals and

¹⁴⁷⁸ Bunshah, 1994, 938; Winkler, Bakish, 1971, 339.

¹⁴⁷⁹ Winkler, Bakish, 1971, 346.

¹⁴⁸⁰ Winkler, Bakish, 1971, 343; Bunshah, 1994, 940.

¹⁴⁸¹ Bunshah, 1994, 938.

¹⁴⁸² Schopman, 1988, 155, 167.

began to study titanium. He used water-cooled copper melting pot in a neutral atmosphere. However, this early research has also been hampered by the low demand for high-purity metals and the lack of high-performance high-vacuum devices in the industry. The development was accelerated only by the investigation of melting and casting of uranium and beryllium for the nuclear industry and the needs of aviation after magnesium.

The considerable part of the vacuum metallurgy was founded before the Second World War, and it was established after the pumps were developed in the processes of uranium separation. Since the mid-1950s, researchers of vacuum metallurgy have their separate symposia and conferences as an independent interdisciplinary research activity.¹⁴⁸³

12.2 Thin Films Technologies

12.2.1 Beginnings

The thin films were first made with forging. As early as in the 18th dynasty (1567-1320 BC), the Egyptian masters of Luxor learned to forge their gold into micrometer leaves. Nowadays, we know how to scrape 0.1 to 0.05 micrometers of thick leaf, which is almost invisible from the sideview.

The copper vases electroplated with silver had been excavated from Sumerian areas in southern Iraq as part of the Baghdad museum until its robbing in 2003. An Aluminium 'Girdle' was recovered from the tomb of the Chinese Western Jin-era general Zhou Chu (Chou-Chum 周處, courtesy name Ziyin 子隱, 236–297). It was made from an alloy of 85% Aluminium, 10% Copper and 5% Manganese which could be produced only from Bauxite by an electrolytic process, after Alumina (Aluminium Chloride component of the ore) is dissolved in molten 'Cryolite'. In 500 CE the Moche of northern Peru used electricity derived from chemicals to gild copper with a thin outer layer of gold by their advanced electroplating technique. They used a very corrosive and a highly acidic liquid solution in which they dissolved small traces of gold. The copper was then inserted into the resulting acidic solution where it then acted both as a cathode and an anode generating the necessary electric current needed to start the electroplating process. The gold

ions in the solution were attracted to the copper anode and cathode to form a thin layer over the copper resembling a solid gold object, even though gold only coated the outermost layer of the copper object. The Moche experts then allowed the acidic solution to boil slowly, causing a very thin layer of gold to permanently coat the copper anode and cathode.

The Europeans rediscovered those methods for applying thin films by Liebig's chemical reduction that allowed the preparation of the silver mirror layer in 1835 and by Luigi Valentino Brugnatelli's (1761 Pavia-1818 Pavia) galvanoplastic silver electroplating in 1802-1805. Brugnatelli was Volta's friend, Lavoisier's promotor and student of firmer Idrija physician Scopoli. Both techniques have been elaborated more than century and a half ago.

The modern term for specialized thin-layer technology is only used for layers built up by the processes of loading the atom onto the atom rather than by thinning a relatively large piece of matter. Thin Films are used in optics as reflective layers, filters and antireflective layers. In electronics, they are used for resistive layers, capacitors and many components in microelectronics. In mechanical engineering, they are used for corrosion protection, wear protection and lubrication. Thin Films, among other things, come in handy as useful and decorative layers on smart windows that leave infrared light in only one direction. Thin films can be prepared by electrochemical processes (galvanic application, chemical application, anodic oxidation), thermal and plasma sputtering (spray) procedures, steam phase chemical (CVD) and physical (vacuum) processes (PVD, fouling, sputtering). Prior to improvements in vacuum materials and systems in the mid-1930s, physical processes remained largely a laboratory specificity.

12.2.2 Thin Films on Glass

The glass might be among the most common materials in human environment which soon attracted the modern possibilities of designing thin films on glass to modify its outlook and other physical properties. The modern thin film coatings are applied to glasses for enhanced performance and increased added value. The coating thin films of metals or chemical compounds to glass surfaces enables a range of additional features.

¹⁴⁸³ Bunshah, 1994, 937–939.

12.2.3 Glassware Development

The glass was first artificially created in Asia Minor and Egypt four millennia ago. Around the beginning of Christian era the experts began to blow glass. A hundred years later the skilful Alexandrians used colored glass. The first glass windows were mentioned at the end of the 3rd century. In 1369 the art of mirror production was already known in Venice.

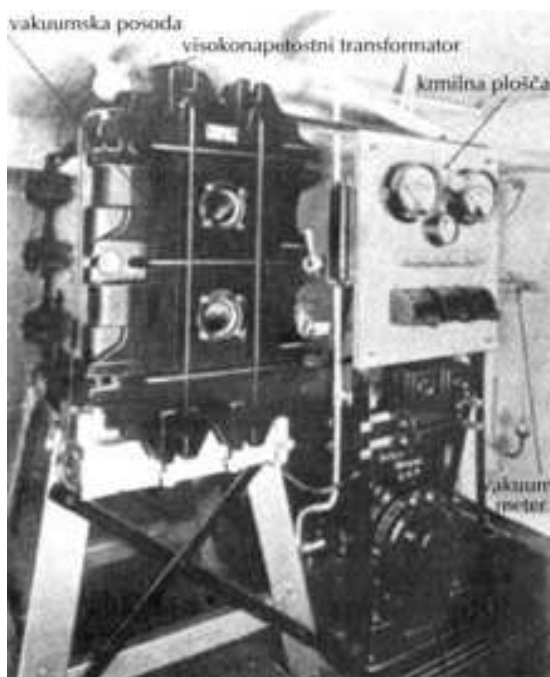

Figure 12-13: 1935 cathode sputtering production device.

In 1675, a quartz glass was found in England, which had a different refractive index due to the inmixed PbO. It enabled the dispute of Newton's theory of chromatic aberration in the mid-18th century. In 1830, Michael Faraday supposed that a common silicate glass is a liquid rather than a compound. After 1930, physicists began to study the structure of the glass, which is not in thermodynamic equilibrium, and its atomic structure is not periodic as in crystals. Thus, the macroscopic glass affected many areas at their differently achieved stages of development. Glass certainly is amorphous while its liquidity at common temperature is basically the question of preferred semantics.

12.2.4 Antireflection Coatings

In 1817 Fraunhofer first made an anti-reflex layer on glass, which he accidentally irrigated in

concentrated H_2SO_4 or HNO_3 . However, he did not try to use his discoveries. Only a decade later, it was explained that interference reduced glass reflectance by applying a thin layer with a smaller refractive index. Gerhard Bauer of the University of Göttingen measured the absolute values of the absorption constant of certain alkaline halide crystals on 27 November 1933. In the vacuum he poured the layers down to a thickness of about 1000 nm, which were most suitable for the measurement. The thickness of the thin layer was measured by the interference of the monochrome light.

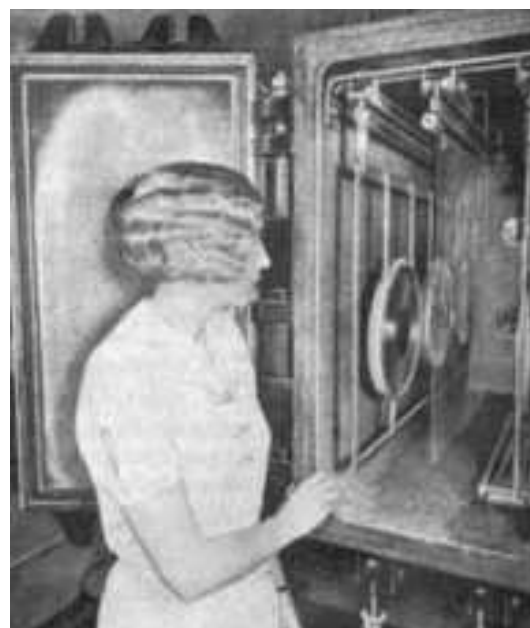

Figure 12-14: The interior of the device in Figure 12-13. The cathode from the silver wire is intended to overlap the matrices for production of the vinyl records.

In 1935, John Strong in Caltech and later at the Hale Observatory in Caltech's Palomar, as well as Smakula from Zeiss, obtained a single-film antireflection glass coating with condensing CF_2 in glass in vacuum.¹⁴⁸⁴ In 1939, C. Hawlet Cartwright and A. Francis Turner of MIT announced that they virtually eliminated the reflectance of glass with a layer of 125 nm thickness and a refractive index of 1.2 to 1.3. The refractive index of the material could be approximated to a given value by controlling the circumstances in its evaporation. Unfortunately, the density and consequently also mechanical toughness decreased, which greatly limited the list of usable substances. They also proposed the use of multilayer overlays and eliminated refraction with

¹⁴⁸⁴ Zinsmeister, 1984, 112–113; Strong, Procedures in Experimental Physics, Prentice-Hall 1938.

Al₂O₃ and SiO₂. Many other proposed substances had excellent optical properties, but they were not resistant to mechanical and other environmental influences. The exception was MgF₂, which became water resistant after applying on hot glass substrates. In 1942, Lyon produced the first stable antireflective single-layered MgF₂ overlay on previously heated glass.

As early as in prewar year 1938, the multi-layer coatings were tested in the US and Europe. The first technically satisfactory solution was published by Auwärter with his two-layered system in 1949.

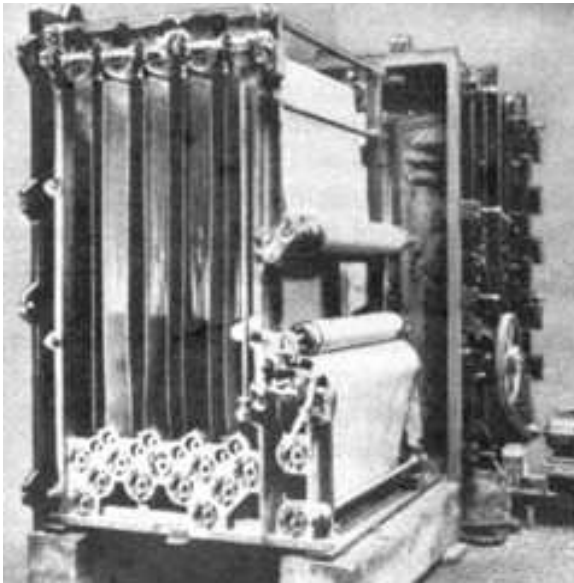

Figure 12-15: The device for covering the cords or textiles with cathode sputtering.

On 22. 2. 1946, Auwärter resigned his service at Heraeus; at the invitation of the Duke of Liechtenstein Prince Franz Josef II he joined Balzers to produce the spotted rhodium mirrors based on his patent and research published in 1939. Today they produce antireflection covering also with more than eight layers.

So, close to the places where Auersperg and Guericke once thought about vacuum the experts developed by important vacuum companies. Balzers has grown three hundred kilometers southwest of Regensburg, and modern Carniolan companies are also close.

12.2.5 Metal Mirrors

The high-reflection coatings were manufactured industrially much earlier than antireflective

coatings. As early as 1835, Liebig reported on silver mirror layers obtained by means of a wet chemical process at the University of Giessen. Several reports have been published by researchers of light bulbs. In 1880, Sawyer and Mann described the vacuum pyrolysis of hydrocarbon vapors for the formation of thin films of charcoal. In 1897, Lodyguine studied the reduction of WCl₄ with H₂ to form thin layers of W. The first metallization process with cathode sputtering was patented by Edison in 1903/1904 for production of phonograph plates (Figures 12-13, 12-14).¹⁴⁸⁵

Robert Wichard Pohl was the son of a shipbuilding engineer in Hamburg. He visited the Johanneum Gymnasium, as well as Franck and G. Hertz did before him. After that, Pohl studied for a year in Heidelberg, where he met Frank and then continued with his studies in Berlin. In his dissertation in 1906, Pohl dealt with the emission of light in the ionization of gases. He studied until the First World War at the Physics Institute of the University of Berlin. During the war he was involved in the development of a new radio technique as a captain. In 1916 he became an extraordinary and four years later a full professor of experimental physics and director of the Physical Institute in Göttingen, where he lived until his death. In 1979, the German Physical Society founded the Pohl Award, to award it every year. P. Pringsheim also began to research in Berlin, but after Hitler's assumption of power, he went to the US and taught in California. He studied the physics of light, especially luminescence and lasers.

In 1839 Hare first reported of the vapor deposition of thin metal layers with arc discharge in a vacuum. In 1907, Pirani patented the use of concentrated cathode rays for the vacuum melting of refractory substances, which Crookes failed in 1879. Pirani did not mention thin films in his patent applications. In 1912, Pohl and Pringsheim attempted to obtain a thin layer on a mirror by evaporation of silver, aluminium and other metals in a vacuum. They made their layers from ceramic (MgO) melting pots.¹⁴⁸⁶ Langmuir studied the rate of evaporation of

¹⁴⁸⁵ Edison, American patent no. 767216 (Zinsmeister, 1984, 110)

¹⁴⁸⁶ Mattox, 2002, 20.

metals in vacuum in 1913 and reported on his thin films.

In 1926, Ioffe's student Jew Frenkel from the Physics and Technology Institute in Leningrad published a presumption of the critical temperature of reflections of metal atoms from the substrate. In the same year, his theory was experimentally confirmed by Khartinov and Semenov at the same institution. Two years later, Semenov and his new assistant, Shalnikov, investigated the formation of a compound in the simultaneous condensation of cadmium and sulfur. In 1956, Semenov was awarded the Nobel Prize in Chemistry.

In 1928, Ritschl described a method for simultaneous silver plating of two interferometric mirrors from a tungsten-welded crucible. The thickness of the silver plating was controlled by a photometric measurement of its permeability. The mirrors were treated with HCl and HNO₃ vapors to improve optical and mechanical properties.¹⁴⁸⁷

Rudolf Ritschl researched in a physics-technical state laboratory in Berlin-Charlottenburg in April 1931. After the Second World War, he was editor of *Fortschritte der Physik*.

In 1930, W. W. Coblenz and R. Stair discovered the high reflectivity of UV rays from the surface of aluminium and described the technique of evaporation of metals in a vacuum.¹⁴⁸⁸ Their discovery was completed by Strong together with Cartwright by in 1931 and on March 8, 1933 in *Phys. Rev.* Their method of aluminium vapor deposition is still valuable today.

Aluminium is also suitable for mirrors, because it almost repulses green light as silver, and UV is much better. Aluminium better adheres to the glass, so we can wash aluminium with water and soap without visible damage even after three months. After six months of air contact, the aluminium mirror did not lose its luster. Therefore, Strong anticipated the successful use of aluminium mirrors in UV-optics and for covering interferometric plates. Strong used a tungsten spiral on which pure aluminium was poured and then evaporated in

vacuum; he exploited the limited solubility of tungsten in liquid aluminium. In 1935, a 100" telescope mirror in Palomar metallized with aluminium.¹⁴⁸⁹

In 1933, O'Brian and Skinner deposited vapours of reflective materials for the targets of X-rays. They placed them in a graphite crucible, surrounded by a heat source in a tungsten spiral. Three years later, Umansky and Krylov studied the structure of thin films of gold and copper with electron and X-ray diffraction. DuMond and Youtz reported a decade later on a double copper and gold coating; with those layers they successfully refracted X-rays. In 1940, G. Hass patented the process of protecting aluminium mirrors with SiO₂. Between 1955 and 1965, with his research group, he introduced the technology of protecting the aluminium layer with MgF₂ or LiF layers for the UV region, while MgF₂ + CeO₂ layers were selected for the visual field. In 1944, Vekshinski investigated the physical properties of condensed layers of pure metals and compounds. He advocated the simultaneous condensation of mixtures of several components of vapors to determine their properties and phase equilibrium.¹⁴⁹⁰

12.2.6 *Hard Coatings*

As always, all began with female beauties. On 19 April 1912, Jeane D Gunder first reported about the titanium nitride in powder form. He filed a patent application for a design for a titanium nitride puff box for the J A Pozzoni Pharmacal Company based in Chicago, established by Joseph A. Pozzoni (1829 England-1885 Saint Louis Missouri) in 1884. Already in 1894 Scovill's Gold Puff Box of Scovill Manufacturing Co of Waterbury Connecticut was produced for Pozzoni. In 1915 Jeane Gunder applied for another design patent for a box with fluting, scrolls and shield on the top with beading on its sides and ends as 'Pozzoni's Boodle Box,' designed for compressed or compacted powder, rather than for loose powder. In the next two decades, it was possible to synthesize more nitrides and carbides from the gas phase.

In 1893, Moissan synthesized a diamond at high pressure. Successful procedures could not be enforced for a long time. In 1911, Bolton and other

¹⁴⁸⁷ Ritschl, 1931, 578–585; Mattox, 2002, 18.

¹⁴⁸⁸ Zinsmeister, 1984, 112.

¹⁴⁸⁹ Mattox, 2000, 5 (i.e. 521); Mattox 2003; Mattox 2018).

¹⁴⁹⁰ Bunshah, 1994, 939.

Siemens researchers experimented to synthesize a diamond at low temperatures below 1100 ° C and low pressures below 1 bar. In this area graphite is thermodynamically stable and the diamond is metastable. However, only partial successes were reported until GE patented the process in 1954 by which they produced larger quantities of industrial artificial diamond since 1957. Soon, efforts were made to use high-conductive diamond layers in electronics. Moissan's work was soon described in the Slovene language: "Moissan came to the idea that for the artificial production of diamonds he needed the heat of an electric furnace in which the dissolved iron is impregnated by pure carbon. Then it is crystallized under the severe pressure during cooling ... pure carbon has crystallized in the shape of a natural diamond!"¹⁴⁹¹

12.2.7 *Thin Films in the Cathode Ray Tube*

With Bolton's inventions, vacuum smelting became very important tool for production of magnetic materials and particularly high-quality resistances and for the application of metals on glass of various cathode ray tubes. The photoelectron components, the transmissive and electrically conductive layers of SnO₂, began to be used for heating elements in aircraft windows during the Second World War. Other types of thin films have found use in resistors, capacitors and magnetic layers, so that electronics are today the most promising area for the applications of thin films.

The displays made of thin liquid crystal layers have become commercially available in the 1960s. However, they were used only for indicators and alphanumeric displays, until improved material quality allowed the production of large displays. Table 12-1 presents an overview of the development of the industrial use of thin films.

12.2.8 *Slovenian Thin Films*

The research of thin films by galvanoplasty has a long tradition in Ljubljana. On 18 March 1856, less than two decades after the first uses of Jakobi's rediscovery of Sumerian, Moche and Brugnatelli's electroplating, Mitteis reported in detail about the history and development of European galvanoplasty

for the Society of the Carniolan Museum in Ljubljana. He showed nicely decorated galvanoplastic prints in copper, reported on gilding with galvanoplasty and illustrated everything with experiments. On November 2, 1857, he explained in detail the known method for aluminium design and predicted its promising use in various crafts and arts.

In the following decades, Slovenians did not have their domestic academic environment that could follow the development of science in the world. By the mid-20th century, Slovenians studied the research of thin films in the United States only through incomplete literature available. Although thin layer sputtering was discovered in London, many pioneering researches were carried out at the universities of the Habsburg Monarchy. The Slovenians helped many discoveries; therefore, the modern research of thin films in Ljubljana has a rich tradition. The modern Slovenian systematic research began in the 1960s. Already in 1955 Saturnus began to produce parabolas for automotive headlamps with vacuum evaporation. The first aluminium filling device was purchased from the English company Edwards from Crawley of West Sussex, where they bought another high-vacuum heat exchanger in 1964. In the 1960s, Iskra-Elektrooptika (now Photon=Fotona) was founded to produce optical devices and thin-film components. Between 1974 and 1977, the Institute of Electronics and Vacuum Technology (IEVT) led by dr. Kansky.

developed the technology of producing a miniature potentiometer. The production was transferred to the Mipot factory in Krmin near Gorizia on the other side of the Italian border to suit better the Slovenian connections with the west. Thin layer technologies are used in Iskra's capacitor factory in Semič, Iskra semiconductors (today Semicon) in Trbovlje, in the production of metal-resistant resistors and liquid crystal displays in the former Iskra's factory Resistors (Upori) in Šentjernej and, of course, in the former Iskra's factory Microelectronics.

One of the more successful companies in the field of thin-layer technologies is Balder, which is engaged in the production of automatic protective

¹⁴⁹¹ Šubic, 1901, 631.

Table 12-1: Thin Films in the industry. Abbreviations for the areas of use of thin films: Metal Mirrors Z, Antireflective coatings, High repulsive layers V, Other optics D, Surface treatment outside the optics P, Hard coatings T, Electronics E

Area	Researcher, discovery and use	Year
A	Fraunhofer soak glass into concentrated acid	1817
Z	Grove sputters metal by discharge	1852, 1853
Z	Faraday sputters metal by wire explosion and explores his thin layer	1857
Z	Plücker sputters metal by discharge	1857
Z	Plücker: the influence of magnetic forces on the formation of a thin layer	1859
Z	Gassiot determines the direction of sputtering of the cathode material	1859
Z	Wright used cathodic sputtering to form thin films	1877
P	Hertz: the rate of evaporation of the mercury	1882
Z	Hittorf sputters aluminium	1884
D	Kundt measures double refraction of thin layer	1885
D	Nahrwold sputters platinum in gases; Kundt measures refractive indexes of thin films	1888
T	Moissan: high pressure diamond synthesis	1893
E	Bolton: melting tantalum in a vacuum	1902
P	Knudsen proves cosine law for evaporation of metals	1909
T	Bolton: diamond synthesis at low temperatures and pressures	1911
T	Titanium nitride in powder form	1912
Z	Pohl and Pringsheim evaporated aluminium from a ceramic vessel from MgO	1912
P	Langmuir confirms the Hertz-Knudsen equation for evaporation	1913
P	Knudsen measures the evaporation rate of the vapor	1915
P	Langmuir: single-molecular thin films	1915
P	Khartinov and Semenov confirm Frank's critical temperature of the reflection of atoms of metals	1926
P	Shalnikov and Semenov condensate cadmium and sulfur	1928
Z	Ritschl simultaneously silvered two mirrors in a vacuum	1928
Z	Coblentz and Stair discover a great of UV-repulsion of aluminium	1930
A	industrial use of antireflective coatings	1930
E	Discrete plastic resistors	1930
Z	Strong evaporates aluminium; O'Brian and Skinner deposit vaporous reflective substances for the X-rays	1933
A	Bauer: absorption constants of alkali halides	1933
V	Pfund evaporates ZnS and combines TiO ₂ with Sb ₂ S ₃ ; A(Ifred)Steinheil at Physikalisches Institut der Technischen Hochschule, Danzig-Langfuhr (Politechnika Gdańska) pours Fe ₂ O ₃ and TiO ₂	1934
A	Smakula patents the vapor deposition of CaF ₂	1935
A	Strong investigates the reflectivity of CaF ₂ ; Strong & Lewis publish the first monograph on thin films	1935–37
Z	Umansky, Krilov: diffraction of electrons and X-rays on alloy of gold and copper	1936
A	Switzerland: a description of the triple layer with the announcement of suitable materials	1938
A	Cartwright and Turner describe the principle of the antireflection layer	1939
E	Selenium rectifiers	1939
D	Selenium photocells	1939
V	Production of Fe ₂ O ₃ and TiO ₂	1940
P	Metallization of plastics, cheap jewelry	1940
A	In the USA and Germany experts begin the production of double layers	1940–1941
Z	Hass: vapor deposition of aluminium	1941

D	Translucent electrically conductive layers SnO ₂ for heating elements at airlock windows of planes	1941
A	Lyon heats MgF ₂ and gets waterproof layers	1942
P	Vekshinsky: physical properties of thin films of metals and compounds	1944
Z	DuMond, Youtz: double layer Cu / Au for reflecting of X-rays; Aron lists publications about thin layer physics	1946
A	Auwärter: double layer Transmax	1949
E	Discrete capacitors	1949
Z	Production of interference films	1949
D	Production of photoconductors and vidicon TV electronics	1949
P	Heat reflux coatings	1949
T	GE: synthesis of diamonds at lower temperatures and pressures	1954
Z	Hass: optimized UV- reflectivity of aluminium layers, LiF protective layer, HgF ₂ + CeO ₂ reflecting layer for visible light	1955–1965
E	Galvanometric and mono-epitaxial layers	1955–1965
D	Solar cells; indicators, alphanumeric liquid crystal displays	1955–1965
P	Corrosion protection layers; thermal absorption thin films, lubrication layers	1970
E	Superconducting layers, passive thin-film circuits; integrated circuits, development of silicon on sapphire for integrated circuits	1975
P	Thin anti-wear layers and heat-resistant thin films	1975
D	Light-emitting diodes, development of electroluminescence screens; liquid crystal displays	1980
D	Electro-chromatic displays	1985

welding filters and other optoelectronic elements. Microelectronics and solar cells were developed in the Microelectronics Laboratory at the Faculty of Electrical Engineering in Ljubljana for almost half of a century.

In the mid-1930s, the German company Leybold developed the first sputters for industry. Two decades later, the Slovenians began to use Leybold's novelties. In 1957 at the first thematic conference at Leybold's headquarters, an association of manufacturers of vacuum coatings was established, which already had 1000 members at the beginning of the third millennium.

The most of researchers of thin films work at the Department of Thin Films and Surfaces of the Jožef Stefan Institute (IJS), especially in cooperation with Balzers. In the first half of the 1960s prof. dr. Boris Navinšek made the first simple "table" device for ion bombardment and ion etching and reported his results in the American magazine in 1965. He launched his prophetic early idea of the advantages of the sputtered protective layer over the glowing vapour depositions, which he presented at a consultation on the new methods of surface protection of the NATO Institute for the Advancement of Research in London in 1972.

Navinšek's group compiled its own ion bombardment device, and the tetrode sputtering equipment Sputron were purchased from Balzers in 1978. In domestic workshops, they manufactured a cylindrical sputtering with titanium cathodes for the application of hard coating on tools. In the late 1970s, after a large investment and numerous studies, Balzers penetrated the promising market with hard protective coatings. In 1983, Balzers began to establish special research and production centers on all continents, with which Balzers secured its leading position worldwide. Balzers supported the cooperation of the Ljubljana Group, which protected the domestic thin-film technology with the patent and the trademark JOSTiN in twenty-three countries of Europe in 1983. On 18 December 1985, the Center for Hard Coatings in Domžale was opened. For their industrial purposes, they apply protective coatings with a Balzers professional device purchased with a financial support of the Slovenian engineering firm SMELT. Following the discovery of high temperature superconductivity in 1986, the research of thin films from modified YBa₂Cu₃O_{7-x} (YBCO) based on sapphire (Al₂O₃) and MgO also started on IJS. Products are used for accurate magnetic field meters. Especially useful is the MgO substrate, where it is possible to achieve a critical

temperature above the boiling point of N₂ at 77 K.
The Department of Thin Films and Surfaces of the
Jožef Stefan Institute acquired a lot of new tools

during the tenure of Slovenia minister Gregor
Golobič (* 1964 Novo Mesto) in 2008-2011.

13 Analyzing Surfaces: New Materials with their Thin Films

13.1 The First Century of Auger Electron Spectroscopy for Measuring of the Composition of Thin Films - Introduction

For two centuries we know how to prepare the thin layer by electrochemical processes, while the use of physical processes of vapor deposition and sputtering is half of a century younger. One hundred years ago, Edison patented the first metallization process with cathode sputtering for production of phonograph plates. Edison's researchers used microscopes when checking filaments in their bulbs and phonograph plates, although they knew that thin-layer scanning was insufficiently accurate and unreliable. The knowledges about thin layer properties were initially far behind their production, just as the first manometers initially stayed behind the achievements of vacuum pumps. After the First World War, a useful solution was offered by Auger electron spectroscopy (AES) as an analytical technique in the chemistry of surfaces and material science. With the AES, we check the surface by measuring the energy of electrons acquired from only few atomic layers thick surface. The energy of the emitted electrons is between 2 keV and 50 keV. Some of them have energies specific to the elements from which they originate, but occasionally they tell us something about the binding states of the atoms.

13.2 Discovery

As with many other discoveries of modern physics, Auger's phenomenon was based on Hertz's research. A quarter of century after the discovery, Einstein correctly described Hertz's photoelectric effect. That success enabled Einstein's Nobel Prize in Physics 1921 awarded only on 9 November 1922. In that time Einstein visited Japan between 17 November and 29 December 1922 and received the award only in July 1923. He gave the money to his abandoned Serbian wife anyway.

That Nobel prize was a compromise, because the Nobel Committee members in their explanation

Otto Baeyer was the son of knight Johann Friedrich Adolf, who replaced Liebig in Munich in 1873 and received the Nobel Prize in 1905. Baeyer belonged to Boltzmann's friendship circle during Boltzmann's professorship in Munich from 1890 to 1894. Boltzmann's recommendations later enabled Meitner's cooperation with Otto von Baeyer as Meitner used to be one of the last Boltzmann's students. Upon the arrival of Meitner in Berlin, Baeyer was already an established researcher of electrons. Under his father's influence, he undertook more chemical research of radioactivity in cooperation with Hahn and Meitner and lectured at the University of Berlin.

In 1913, Chadwick received a scholarship entitled "1851 Research Fellowship" from the Royal Commission for the Exhibition of 1851, as did his boss Rutherford—eighteen years earlier in 1895. Chadwick emerged from a poor environment in the suburbs of Manchester; so, he wanted to spend his scholarship at home in England and save some pounds. However, the rules did not allow that, and in the autumn, he went to the Berlin Laboratory of Rutherford's colleague Geiger at Physikalisch-Technische Reichsanstalt. Chadwick immediately discovered the continuous spectrum of β -rays just before the start of the First World War. The discovery was confirmed by Meitner in the neighboring Berlin laboratory, while similar research was published at the same time by Curie's Parisian assistant of Polish genus Jean Danysz in Warsaw and Paris before he became another early victim of the Great War.

deliberately did not mention the still polemical theory of relativity. In 1921, Meitner was a visiting professor at the University of Lund in Sweden where she was "cheering on" Einstein in Swedish academics' networks. She was of a Jewish family like Hertz and Einstein, and antisemitism slowly showed horns among their colleagues, especially with the Hungarian Slovakian Lenard and the Bavarian Stark onboard. She became an assistant professor at the University of Berlin just few months before Einstein received the prize. In Berlin, she attended weekly physical seminars with

Einstein, Planck, Nernst, Laue, G. Hertz, Franck, and the Viennese Schrödinger, who took over Planck's chair in 1928. Meitner had the opportunity for her experimental research, which until then had not yet been obtained by any female scientist except for a decade older Curie; so, the men wanted to listen to her opinion. Of course, she was also beautiful and unmarried.

On 29 March 1914, Einstein arrived in Berlin while his Nobel Prize has heightened interest in the photoelectricity and associated electron bombardment among the local researchers. The opportunity was best used by Meitner. She continued H. Hertz's work, begun in Berlin three decades earlier. She was interested in the β -decay process. Prior to her departure for military nursing, she and von Baeyer studied and photographed beta-rays from thorium and actinium¹⁴⁹². Similar research was published by Chadwick and Rutherford in Manchester.

The Norwegian astronomer **Svein Rosseland** from Kvam studied at the University of Oslo. During the war, the centers of science moved to neutral lands. So, at the end of 1920 he began to study at the Bohr Institute in Copenhagen, where he met Einstein. Between 1928 and 1965, Rosseland was a professor of astronomy in Oslo, and from 1954 to 1965 he was the director of the observatory at the same time.

Adolf G. Smekal studied in Vienna and Berlin and graduated in 1917 in Graz. Following the retirement of Charles Schmidt in 1927, he became a "personal" full-time professor and director of the new laboratory of theoretical physics at the University of Halle. In 1933, he announced a combined scattering of light. He obtained a real regular full professorship only under Hitler's regime in 1934 and retained it until the end of the war because he became the supporting SS member upon Hitler's enthronement and joined Nazi Party four years later in 1937. In those ugly times the Nazi affiliations helped much more than the talent. After the war he was a professor at the Technical University of Darmstadt until 1949; then he returned to Graz University and remained there until death.

Chadwick was a deeply devoted absentminded scientist: he did not read newspapers and he did not believe in any war. That's why he was surprised by the war, in the middle of his experiments in Berlin, while he suspected nothing serious. The Germans turned him overnight from a colleague into an enemy and a prisoner. After the war, he joined Rutherford in Cavendish; there Chadwick and Ellis bombarded atomic nuclei with

Wilhelm Lenz from Frankfurt by Main, studied mathematics and physics at the universities of Göttingen and Munich, where he received his doctorate from Arnold Sommerfeld in 1911 and researched as his assistant. At that time, he began to work with Otto von Baeyer. During Lenz's doctoral studies Baeyer discussed with Sommerfeld the difficulties in measuring the photoelectricity. In 1920, Lenz became an associate professor at Rostock, and in the following year he took over the chair at the newly established Institute of Theoretical Physics in Hamburg. Among Lenz's students was Ernst Ising, author of the famous model of ferromagnetism published in 1920. Between 1922 and 1928 Lenz's assistant was the celebrated Pauli, who developed a new center of atomic physics in Hamburg. As a Viennese, Pauli enabled his boss Lenz's close contacts with the other Viennese Meitner.



Wilhem Lenz (* 1888; † 1957)

¹⁴⁹² Rosseland, 1923, 180.

electrons and scattered monochromatic γ -rays. In 1921 and 1923, the Frenchmen René Ledrus and Maurice de Broglie bombarded copper with the rays from radioactive rhodium. The copper ions radiated their weakly bound secondary electrons with precisely determined energies. Upon returning from war, Meitner's—measured the secondary electrons, which are generated by the rays from the nuclei. Chadwick and Ellis argued that this is a continuous spectrum of β -rays. In 1922, Meitner's experiments showed that electrons depart from the bombarded nucleus at initially determined speeds specific to each type of core. The continuous Chadwick's spectrum is only a consequence of secondary influences on the electron. The question was interesting enough that Germans subsequently translated the reports of Ellis's measurements. The views of Geiger, Chadwick, Ellis and other Rutherford's collaborators on secondary electrons differed from the opinion of Berlin and Copenhagen researchers,¹⁴⁹³ regardless of close personal relationships between Bohr and Rutherford, and the similarity of their models of atom. The wartime dispute between Germans and Rutherford's researchers was an introduction to widespread disagreement between the summer of 1923 and December 1927, when there was a sharp exchange of views between Cavendish and Vienna on the measurements of artificial nuclear reactions and Rutherford's model of atoms.

Meitner's ideas were supported by the important young researchers of quantum theory, Rosseland and Smekal. The Viennese Smekal argued that secondary electrons fly off after a direct quantum transition without radiation. In 1922, Rosseland announced the β -ray with discrete energies, now called by Auger's name. Already before Rosseland's publication, secondary electron was discussed in German universities. Even before the outcome of Rosseland's paper in December 1922, Lenz wrote Meitner about " β -rays that emerge from a nucleus with exactly defined energies." Rosseland published his ideas on 31 January 1923, and in few months, Bohr included them in his penetrating theory of structure of atoms.¹⁴⁹⁴

To resolve the contradictory claims and confirm Rosseland's forecasts, Meitner bombarded the target made of the isotope thorium with electrons

from the radioactive isotope of bismuth in June 1923.

Lise Meitner was born in a Jewish family of lawyers, like H. Hertz did in Hamburg. Since the girls of her time were not allowed to attend gymnasium, she graduated after the private lessons. In 1902 she began studying with Boltzmann as one of the first female students of physics and the second woman who received her doctorate in theoretical physics at the University of Vienna. On 11 December 1905, she defended her doctorate on the translation of heat in non-homogeneous bodies according to Maxwell's equations. Boltzmann and Exner marked her knowledge as perfect, while the mathematician Escherlich judged that it was just enough. Boltzmann was already very ill at that times and received Meitner at his home doors; after they parted, Meitner heard the heartbreaking lunatic cries from the inside of Boltzmann's house.

Escherlich's estimates finally turned Meitner into experimental physics. Boltzmann encouraged her because he knew her problems well in his own family. Boltzmann's wife, half Slovene Jetti Aigentler, was the first student of physics at the University of Graz. Thus, Jetti indirectly greatly contributed to the implementation of Meitner, as she began with female physics education in the Habsburg monarchy. After Boltzmann's suicide, Meitner went to Berlin in 1907 where she was not permitted to Planck's lectures (Figure 13-1. At that time, Vienna lost its leading position in the experimental research of radioactivity and atmosphere, although there were no shortages of excellent researchers, among whom was Lisa's younger peer, the half Slovenian Sirk. Amongst the strict Prussians, Meitner felt even more difficult than in the cosmopolitan Vienna. The professor Fischer allowed her to research at his laboratory as soon as she promised to use the back door of the institute and never enter during the men's working time. In 1902, Fischer received the second Nobel Prize in Chemistry, but he committed suicide after the war. Immediately upon arrival in Berlin, Meitner began to work with Baeyer and most of all with Hahn (Figure 13-2). Hahn was four months younger than Meitner and he worked in Fischer's lab already for one year. Hahn and Meitner studied together over three decades and developed their own numerous scientific

¹⁴⁹³ Ellis, 1922, 303; Meitner, 1923, 54; Meitner, 1922, 54, 143, 145; Rosseland, 1923, 173.

¹⁴⁹⁴ Rosseland, 1923, 173, 176, 181; Bohr, 1970, 516.

discoveries. In 1912, Meitner assisted Planck, who was not so strict as Fischer against the more advanced female scientists. The following year she became a permanent member of the Society of Emperor Wilhelm. The first two military years she served as a nurse in the Habsburg army. Immediately after the war, she began to run her own group in the radio-physical institute, and together with Hahn they discovered the element protactinium. In 1926, Meitner was promoted to a post of associate professor at the University of Berlin, and two years later Hahn became director of the Chemical Institute of Emperor Wilhelm (Figure 13-2). Meitner wrote a discussion on the radioactivity at the invitation of the editor of the German Encyclopedia Brockhaus. The editor thought he was dealing with Mr. Meitner, as he only read those papers under which she was signed with the initial "L". After signing her contribution with her personal name, he realized that he was dealing with a woman. Her contribution was promptly rejected.



Lise Meitner (* 1878; † 1968)

The bombarding electrons hit the strongly bound electrons from uranium atoms. In the transition from the resulting excited state to the excited state with lower energy or in the ground state, the uranium ion delivered a secondary, weakly bound electron which was predicted by Rosseland. De Broglie's and her own experiments convinced Meitner that the secondary electron emanates from

the same atom that absorbed electron of bismuth. The secondary electron, of course, was carrying a characteristic discrete energy of the atom as she intended to prove. Chadwick's presumption was therefore considered for normal beta radiation, not for secondary electrons that were predicted by Rosseland and are now called Auger's electrons. The Germans mitigated at least some of their humiliatingly lost war by correcting Chadwick's hypothesis.



Figure 13-1: Lise Meitner with Laue and Dutch physicist Dirk Coster in the mid-1930s, in front of their institute at Berlin¹⁴⁹⁵

Meitner alone published the measurements of secondary electrons and the first confirmation of Rosseland's forecast, although Hahn and von Baeyer participated in previous research. She announced that she would continue to investigate the electron emission course with Hahn¹⁴⁹⁶ but she did not publish any subsequent studies. Researchers of radioactivity and theoreticians of the Bohr's circle did judge her research to be quite promising. It was aligned with the predictions of Copenhagen quantum mechanics while Bohr's fans were basically not interested in its use in the investigation of solid matter. In the 1920s, Laue proposed Meitner for the Nobel Prize in view of

¹⁴⁹⁵ Crawford, Sime, Walker, 1997, 28.

¹⁴⁹⁶ Meitner, 1923, 62–64.

her research of the beta and gamma spectra. Unfortunately, the beautiful lady never received her Nobel prize. At the same time, A. H. Compton discovered the phenomenon of scattering of X-rays at St. Louis University in St. Louis. He used a similar Bragg's experimental technique as Meitner, and in the interpretation of his discovery, he used the term photons among the first. Compton was still only a child at the time of Boltzmann's lectures in Saint Louis in 1904. He learned Bragg's technique during his studies at Rutherford's Cambridge in 1919, where he collaborated with Chadwick and the Nobel Prize winner, W. L. Bragg, before the latter took over the chair in Manchester. In 1927, he earned a half of the Nobel Prize in Physics.



Figure 13-2: Meitner with Otto Hahn in Berlin¹⁴⁹⁷

Women, however, slowly changed science. Meitner introduced a characteristic order of a good housewife in her laboratory, thus protecting many previously unknown radiation hazards.

Many of the worst disasters were soon associated with her gender issues. With Hitler's assumption of power, the Jewish woman Meitner lost her professorship at the University of Berlin, although she was able, as an Austrian citizen, to pursue the research work of the head of the physical department of the Imperial Chemistry Institute of Kaiser Wilhelm. When Hitler annexed Austria in 1938, she had to escape. Thus, she could not sign a paper on the discovery of the fission of nuclei that she was preparing with Hahn. She secretly came to Bohr where her nephew the Viennese Frisch

¹⁴⁹⁷ Crawford, Sime, Walker 1997, 32.

worked at the Institute of Theoretical Physics at the University of Copenhagen. He got married in Sweden and became a Swedish citizen in 1949. Meitner's relations with Sweden have been close since 1921, as she was an external member of the Swedish Academy. In 1960 she moved to Cambridge. The elegant lady of lower stature was able to make difficult mountain trips even at a later age. She died unmarried only three months after her longtime colleague, Hahn. In 1992, her name was used for a chemical element with the number 109. Immediately after the war, Hahn received the Nobel Prize in Chemistry in 1944. The European Physical Society has awarded the Lise Meitner Prize since 2000. In 2002 it was awarded to the professors James P. Elliot and Francesco Iachello who explored the nucleus of the atom.



Figure 13-3: The measuring devices of Lise Meitner in Berlin¹⁴⁹⁸

The inventive research and conversations at the Berlin Physical Seminar prompted Einstein to think deeply about photons a few months after the discoveries of Meitner and Compton. Meitner reported on her discovery on 26 June 1933 in *Z. Phys.* Even though it was the leading German magazine, her twenty-five-year-old younger acquaintance the Parisian Auger did not read her paper in time. Thus, he discovered the phenomenon independently two years later when he was experimenting with X-ray samples for his doctorate in Paris. In 1922, Auger and François Perrin evaluated the number of electrons in the atoms by tracks observed in Wilson's cloud chamber. During the preparation for his doctorate, Auger experimented to demonstrate in the same cloud chamber (foggy cell) the entire course of

¹⁴⁹⁸ Sime, 1998, 60.

excitation of gas atoms with photons: the formation of a photoelectron, the emission of quantum radiation, and the absorption of the quantum with the formation of another photoelectron. After the formation of the primary photoelectron, an additional electron was noticed at the same point. At first, he estimated that it was due to the re-absorption of the quantum of radiation in the atom from which it was derived. In 1926, during preparations of his PhD thesis the publication, Auger discovered that additional electrons were due to the radiation-free transition that Rosseland had already announced. Of course, it is a little surprising that he knew Rosseland's forecast, but not its first confirmation in Meitner's measurements. The Auger's electrons emitted by radiationless transition have energies specific to the atom they originate from. The phenomenon was named after the Frenchman Auger, not by the German Jew Meitner; the decision was both sexually and nationally prejudiced. The French tried to restore their dominance in science, and the Berliner researchers did not want to acknowledge successes of any Jews, even less the Jewesses. As a woman Meitner had many problems in her career, despite her unquestionable abilities. The Germans did not particularly fiercely support her priority efforts. Therefore, the discovery of Meitner and an additional electron included are called by Auger, as supported by a strong French school of radioactivity researchers.

phenomenon." Thibaud helped Maurice de Broglie to eject Auger's high-energy electrons immediately after Auger's discovery. The French atomist J. B.

The Parisian **Pierre Auger** finished the École Normale Supérieure. Together with François Perrin they led advanced young scientists. They gathered around François's father Jean Baptiste from the University of Paris as he received the Nobel Prize shortly after Auger's doctorate. The characteristic of Perrin's school was particularly strict atomism, very like Boltzmann's School with Meitner included. After his doctorate, Auger researched at the Parisian Institute between 1927 and 1941. In 1937 he was there as a professor. In 1938 he discovered wide atmospheric Auger's lines. In the war years 1941-1945 he researched in England and in the USA. After returning to France, he was initially the Commissioner for Atomic Energy, and he was director of the UNESCO Science Department between 1948 and 1959. He assumed high administrative functions related to space research. His cosmic rays were measured on the 4158 m high glacier Jungfrau in the Bernese Alps (Figure 13-4). His colleague, Paul Ehrenfest, the son of physicist Paul, left this world after his tragic accident. In the older years, Auger also wrote about the philosophy of science. It is not known whether he regretted that he took over Meitner's priority, but they both met each other in their deeply advanced old ages.



Figure 13-4: Pierre Auger (* 1899; † 1993) (left) and co-worker Paul Ehrenfest (* 1916; † 1939) set up a measuring device on the hill in the Swiss Alps

In later years Auger's younger colleague Thibaud called the discovery a "composite photoelectric

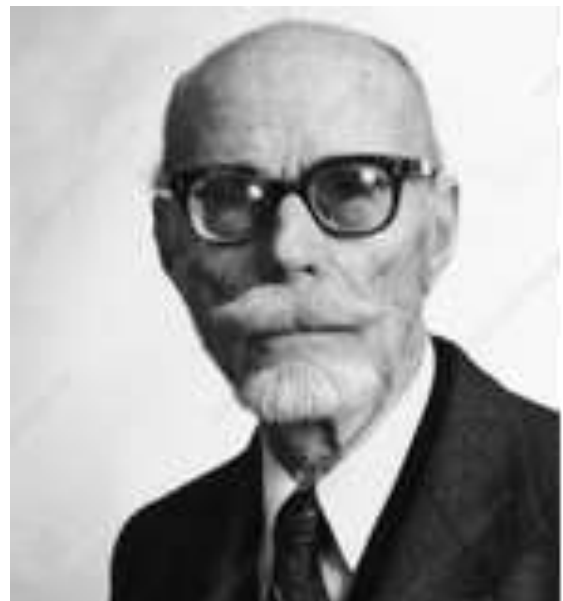

Pierre Auger (* 1899; † 1993)

Perrin's school was particularly interested in the absorbed energy that the atom did not radiate but eject in particle form. Auger observed the X-ray diffraction of argon, xenon, and krypton, and Thibaud complemented the measurement with a similar scattering of γ -rays.

Maurice de Broglie, the older brother of Nobel laureate Louis, studied in Marseille. Between 1895 and 1904 he served as a maritime officer, and then lectured at the Collège de France until the end of the Second World War. Since 1921, his assistant was Thibaud from Lyon, where Thibaud graduated and took over the chair in 1935. During the war, Thibaud was head of the School of Physics and Chemistry in Paris, and later he returned home and led the Institute of Nuclear Physics (Institut de Physique Nucléaire de Lyon).

In 1935, the English chemist Haworth reported on his experiments with solid substances. He noticed the peaks in the secondary distribution of electrons that were not dependent on the initial energy of the incident electrons. He did not specifically deal with surface analysis, as he continued Fischer's research on sugars with X-ray structural analysis. In 1937, he received the Nobel Prize in chemistry, and ten years later he became a nobleman.

Compton's PhD student at the University of Chicago Robert Sherwood Shankland in 1935, Bohr's student Jacob Christian Georg Jacobsen of Institute of Theoretical Physics, Copenhagen in Nature, Eric Pickup of physical lab in Manchester in Nature, and Evan James Williams of physical lab in Manchester in Nature as Bohr's guest at Royal Danish Science Society, published similar experiments as Auger's in Wilson's cloud chamber (foggy cell). In 1936 and 1937, they examined the laws of conservation of energy and the momentum.

Between both wars there was already much laboratory or even industrial analysis of thin films. When the production of thin films in the second half of the twentieth century required the development of the gauges of their properties, they began to choose useful procedures. In 1953, John Joseph Lander (* 1918) of Bell Labs in Murray Hill of New Jersey linked the discoveries of Haworth and Meitner. He proved that the individual peaks in the secondary electron

distribution were due to Auger's electron, which was not known to Hawroth. Lander experimented with carbon, oxygen, beryllium, aluminium, nickel, copper, barium, platinum and oxides. He was particularly pleased that most of the elements could yield typical Auger electrons with low energy from the surface layer, only a few atoms thick. The addition of one or two layers of atoms has greatly altered the results of the experiment. Therefore, he announced that the electron excitation of Auger electron signals would be interesting for accurately determining the absorption coefficients and for the formation of solid surfaces in a vacuum.¹⁴⁹⁹ Although the technique was developed for the study of surfaces, it was difficult to detect the Auger peaks; unfortunately, they were loaded onto a large background of secondary and reversed scattered electrons (Figure 13-5).

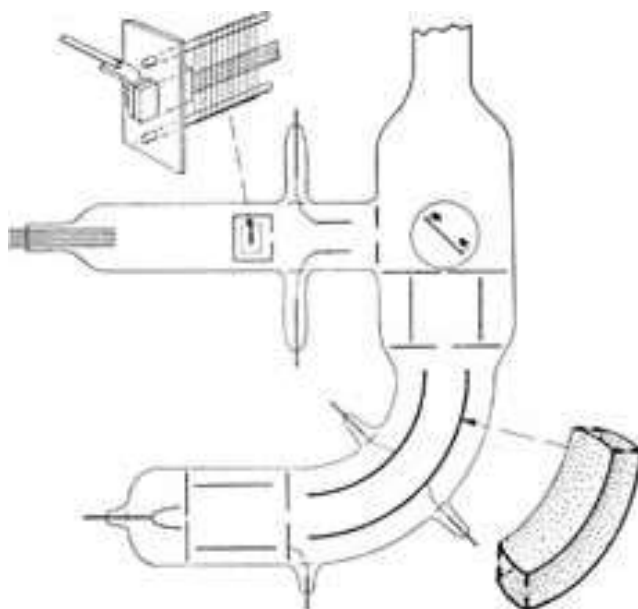

Figure 13-5: Spherical electron speed analyzer, electronic rifle and target in Lander's experiment¹⁵⁰⁰

13.3 Application to Industry

In 1966, LN Tharp and EJ Scheibner showed that Auger's peaks can be observed in the form of a peak in the spectrum of the emitted tungsten electrons using the Low Energy Electron Leak (LEED). Larry A. Harris of General Electric Research and Development Center, Schenectady, New York presented the AES as a useful tool for

¹⁴⁹⁹ Lander, 1953, 1367.

¹⁵⁰⁰ Lander, 1953, 1383.

surface analysis next year. He showed that the use of synchrotron light enhances the spectrum characteristics that would otherwise be difficult to detect in more direct measurements. Such spectra were termed as derived spectra and after Harris's interventions became sufficiently sensitive to useful measurements.

New methods for obtaining derived spectra were soon offered by Weber and Peria with LEED. In 1969, P. W. Palmberg, G. K. Bohn and J. C. Tracy used a cylinder mirror analyzer. They achieved better sensitivity to electrons, higher speed, sensitivity and signal-to-noise ratio according to the LEED detector. The door finally opened, and we could study the chemical composition of surfaces, details of surface cleaning, gas adsorption or metal loading onto surfaces. The composition of surfaces reveals their somewhat hidden structure.

Around 1970, the AES established itself as a routine method for analysis. Today, it's the most common used method for exploring surfaces, thin films and substances on the boundary layers. It is useful for exploring surfaces 0.5 to 10 nm thick where it has good depth resolution and a suitable sensitivity of 100 ppm for most elements besides hydrogen and helium.

13.4 Auger Electrons in Slovenia

Since 1973, the researchers of Institute of Electronics and Vacuum Technology (IEVT) in Ljubljana had analyzed their samples with the AES at the Viennese Technical College or at the Max-Planck Institute of Metals in Stuttgart. Kansky encouraged his IEVT collaborators to publish their own papers. So, they had already learned about the AES method when they acquired their first raster micro-analyzer for detecting Auger's electrons in the spring of 1977. The decades of the successful use of AES in Ljubljana started (Figure 13-6).

The LEED Auger spectrometer also works on the IJS. In 1997, the Institute of Metals and Technology in Ljubljana acquired the Auger electronics high-resolution spectrometer for field emission with an X-ray photoelectron spectrometer equipped with a "in situ" breakage device of samples. The device offers the following options:

- High-resolution spectroscopy of Auger electrons (HRAES)

- Scanning microscopy of Auger electron (SAM)
- Scanning electron microscopy (SEM)
- X-ray photoelectronic spectroscopy (XPS)
- Spectroscopy of the lost energy of the reflected electrons (REELS).



Figure 13-6: Auger's spectroscop of PHI, SAM, 545A of Physical Electronics Inc. Minnesota in the surface analysis laboratory at the Department of Surface Technology and Optoelectronics of the IJS (until 2003 Institute for Surface Technology and Optoelectronics - ITPO)¹⁵⁰¹

The leading Slovenian researcher of Auger electron spectroscopy professor Anton Zalar (1943-2006) was born in the middle of World War II in Ljubljana on May 28, 1943. He studied at the Secondary Technical School, majoring in metallurgy. He graduated in 1962, and then continued his higher education at the Faculty of Natural Sciences and Technology, University of Ljubljana, where he studied metallurgy at the Department of Mechanical Engineering and graduated in 1969. After many years of work at the Institute of Electronics and Vacuum Engineering (IEVT), he enrolled at the same faculty for postgraduate studies, where he received his master's degree in 1981 and his doctorate in 1987. He was first elected assistant professor at the Faculty of Natural Sciences and Technology of the University of Ljubljana in 1992 in the field of physical metallurgy and in 1998 he became an associate professor. On October 12, 2004 he was awarded the title of full Professor of Physical Metallurgy at the Faculty of Natural Sciences and Engineering, University of Ljubljana. Until 1995, Professor Anton Zalar was employed at the Institute of Electronics and Vacuum Engineering (IEVT) and then at the Institute of Surface Technology and Optoelectronics. He was the

¹⁵⁰¹ Zalar, 1979, 402.

longtime director of this institute while he was also the head of the Surface and Thin Layer Analysis Laboratory for over 20 years. Since 1988, he has been the leader of a research group that has conducted basic and applied research. After joining this research group within the framework of the Jožef Stefan Institute in 2003, he was a long-time successful head of the Department of Surface Technology and Optoelectronics. Professor Anton Zalar's research work focused on investigations of surfaces and thin films by Auger electron spectroscopy. He has established himself in this field at home and in international professional circles, as a valued invited lecturer at many international conferences, foreign universities and institutes. Among the great achievements of prof. Zalar it is worth mentioning the introduction of a very significant refinement of the method of investigation of thin-layer structures, which significantly improved the depth resolution in the nanometer region and enabled the investigation of chemical reactions and diffusion at the internal phase boundaries of multilayer structures. This research method is named after Professor Zalar and is still an integral part of all advanced analytical instruments for the investigation of surfaces and thin films. As an internationally recognized expert, Professor Anton Zalar managed intense contacts worldwide. Since 1975 he has successfully collaborated with the Max-Planck Institute research of metals (Metallforschung) in Stuttgart, and even with the Karlsruhe Kernforschungszentrum, Institut für Technische Physik. He has collaborated with the Institute of Technical Physics at the Hungarian Academy of Sciences, with the Department of Microelectronics at the Slovak Technical University, with the Institute of Physics of the University of Hohenheim, with the Department of Technical Physics of the University of Kaiserslautern and with the Institute of Physics of the University of Münster. The results of his research were his 360 publications, including 208 scientific and professional articles published by himself or with his colleagues in reputable scientific and professional journals at home and abroad. These works have been cited more than 1400 times, which shows us the extraordinary impact of Professor Anton Zalar's work. He has been a valued guest at foreign institutes and universities with more than forty invited lectures. For his work in the field of surface investigations using Auger

electron spectroscopy, Professor Anton Zalar has twice received the Boris Kidrič Fund Award.

13.5 Conclusion

The cognition of the problems of Meitner is instructive for today's time. It is intertwined with an interesting story about the half of century that has passed from the discovery of AES to its use in industry. The discovery of early high-energy physics researchers was used in the study of solid matter. Exploring the basic laws of beta decay has benefited the industry. That is how the story links today the opposite areas and genders of researchers in physics. Perhaps the finding points of contact between them could contribute some ideas needed to solve the modern crisis of physics. The mixing of areas of research and the gender is always productive, while the mixing of different scientific traditions developed in geographically distant areas might bring even more newly developed approaches. Therefore, its high time to examine the circumstances which brought modern western vacuum technologies to the Far East.

III. Intermezzos: Export of Vacuum Design into Foreign Lands & Unexpected Uses

14 European Vacuums for Far Easterners

14.1 Hallerstein Exports Carniolan Science

The Carniolan Far Easterner Hallerstein indeed served the three masters: the Jesuits, the pope and the Chinese emperor. He also had to serve his European magnate who used to be his main financial backers. It may have been a price for a meaningful life, because Hallerstein was an important man, otherwise firmly rooted in his spiritual world. At his leading role at the Beijing astronomical bureau-office he was an all-time-superior culture broker.

According to the overall scientific work done, not only astronomical and that related to vacuum, Hallerstein was one of those famous Carniolan scientists who have left important work in the global scale far from his native blooms. He is the greatest Carniolan astronomer who has worked outside his home country. In addition to the astronomical observations, and presentations of vacuum devices to the imperial court he also participated in regulating the calendar, measuring the positions (latitude and longitude) of the places in China, and thus also in surveyors' measurement, as mapping of the vast state of China..

14.2 Vacuum Pump in Hallerstein's Beijing: Voids Allowed in the Forbidden City

Most of Chinese and even Russians love to trace the modern western technologies as the development of their own older designs. It is not easy to judge. Like in archeology which covers every detail of European soil but neglects much more sub-Saharan Africa, Latin America or Asia, all traces of early vacuum technologies are strictly researched in Europe and in ancient Hellenic frames, but not elsewhere. We are convinced that at least the Far Easterners must have had some accesses to vacuum technologies prior to their borrowings from the west; but without much decisive proofs we will just try to describe the transfer of Jesuitical and Dutch vacuum equipment to Beijing and Edo (Tokyo). The Chinese historical thought welcomed the corresponding idea that modern European knowhow originated from inventions already endorsed in ancient China. Needham said that over the centuries Arab traders passed on to Europe the Chinese invention of the compass: unfortunately, there is no evidence that the Arabs knew of the compass so early. The Chinese used a wind turbine for pumping water for thousands of years before the Europeans. However, similar wind turbines occurred in Europe in 1716, twenty-three years before the first known drawing came from China to Europe, and the Swedes started to explore the Chinese models only in the 1760s.

Considering the vacuum, zeros and the infinities, the Far Easterners might have more productive approaches to those puzzles, but there is no unquestionable trace of vacuum barometers and vacuum pumps outside Europe before the middle of 17th century. For one reason or another, it took a century before those tools were officially presented to the most notable Far Eastern network in the palace of the Chinese emperor.

With the help of the superior in Canton Joseph Louis le Fevre (Fèvre, * 1706 Nantes; SJ 1722; † 1780/1783 France), the newly arrived French missionaries brought to Beijing an excellent great new reflection telescope, numerous gifts and the first vacuum pump on 12 January 1773.

The newcoming missionaries vacuum researchers were the watchmaker Méricourt¹⁵⁰² and artist Panzi¹⁵⁰³ who traveled under the orders of French Minister Bertin.¹⁵⁰⁴ They examined the operation of the pump during their Parisian preparations for the Beijing route. Both Jesuits knew the puzzles of vacuum techniques. On 18 January 1773, the emperor ordered the pump to be transferred to the Ruyi Guan building (Jou-y-koan), where European artists worked.

Benoist and Sichelbarth introduced a pump to the emperor in spring and explaining its operation. After the death of Hallerstein in 1779 or 1780, Le Fevre returned to Paris and personally informed Minister Bertin of vacuum successes in the forbidden city of the Chinese Emperor. Of course, the European vacuum pump has been developing in Europe for so many centuries, so that it was possible to afford a complete version for the emperor.

Benoist worked for a few months on the pump to train the Chinese for a demonstration. He explained to one Chinamen how to use it to become the helper. He selected the most interesting experiments for the emperor, got them drawn to the copperplate and explained it in a small booklet for emperor. The pump was put into place with controlled temperature to prevent any damage by the excess cold. Méricourt and Panzi have taught the eunuchs to handle the pump in order by protecting it from the colds. Their instructions were translated by Yuen-Ming-Yuen.

In the first vacuum experiments in Ru yiguan (Jou-y-koanu), four eunuchs propelled the pump on March 10, 1773. Three missionaries, the

mechanics-horologer Méricourt who just arrived in Beijing, the horologer Archange (Archangelo) who arrived in Beijing in 1764 and the clockmaker Jean-Mathieu Tournu de Ventavon (Wang Dahong, Matou, 汪達洪, 1733-1787) who replaced Gilles Thébault (1703-1766) in 1766, dismantled all parts of the pump in the workshop. The eunuchs were very enthusiastic when Benoist showed them the compression, stretching and other properties of the air. At eight o'clock in the evening, the emperor requested explanations for all the experimental results. He got acquainted with the inside of the pump and the parts that were hidden in the assembled device. Benoist had to explain to him the importance of the many copper plates that were attached to the device. The emperor instructed him to repeat all the experiments of Ruyi Guan (Jou-y-koan), where the performances were prepared for him by the eunuchs.

The next day, March 11, 1773, the eunuchs reported to Benoist right after his arrival at Ruyi Guan (Jou-y-koan). They told him about the events of the previous day and about the Emperor's responses. The Emperor ordered the preparation of new experiments. Therefore, Benoist disassembled the pump to inspect if all parts were in good condition. In the afternoon, Benoist explained to the Emperor the use of various valves, large pipes put opposite to the piston, which prevents the access of external air to the pump, and an external safety valve preventing the passage of the outer air into the recipient. When the emperor was acquainted with all the parts of the pump, he asked if they could start experimenting. Preparation took some time, while the emperor asked thousands of questions, as was the custom. Benoist presented twenty-one eminent experiments to the emperor. With the first six demonstrations he proved the air pressure. The experiments followed each other. While the emperor listened to the explanation of the previous experiment, they were preparing the next one. Benoist also brought a barometer and a thermometer into the room. The emperor asked several questions about how the air reduces the mercury level in the barometer, how it raises the water in the pump, and why the change in pressure is proportional to the change in the amount of mercury. Benoist served him with explanations that were then common in Europe. He described how the density of air changes with weather conditions.

¹⁵⁰² The father Hubert de Méricourt (Li Tsuen-Hien Si-Tschen, * 1. 11. 1729 France; SJ 8. 1. 1754 France; † 20. 8. 1774 Peking). Arrived in Peking on 12. 1. 1773, but died soon, shortly after Beijing vacuum experiments (Pfister, 1934, 975).

¹⁵⁰³ Brother Joseph Panzi (Giuseppe Pansi, P'an T'ing-Tchang, Jo-Ché, * 1734 Cremona or Florence; SJ Genova (Genes); † before 1812 Beijing) arrived in China in the year 1771 or on 12. 1. 1773 under the flag of the French Jesuits, although they already banned the Jesuits in France previously (Pfister, 1934, 971).

¹⁵⁰⁴ Henri-Léonard-Jean-Baptiste Bertin count de Bourdeilles (* March 24, 1720 Périgueux; † 1792 a health resort called Spa in then Habsburg Belgium) was the Minister of Agriculture, and in the year 1774 as well as foreign affairs. He was also a honorary corresponding member of the Parisian Academy (Amiot, 1774, 519).

The second group of Benoist experiments proved the elasticity and compressibility of the air. These experiments were very appealing to the emperor. The use of mercury in this pump may have been related to many questions about mercury that the emperor asked during the demonstration.

In Ruyi Guan (Jou-y-koan), Benoist named the pump as a "pipe for exploration of air" (yan qi tong (yen chhi thung), Nien-ki-tung in the French spelling of Chinese language). The emperor felt that the word hou (Heou in French) should be used instead of yen (Nien in French), since it is more noble, used in classical Chinese books to describe celestial observations, for observations in determining agricultural activities and changing the seasons. That is why the emperor chose the name "pipe for observation of air" (hou chhi thung, in the French record Heou-hy-tung).

At the end of the presentation of the pump, the emperor thanked his wives and other ladies for attending experiments. After prolonged presentation, during which he constantly stood near the pump, he returned to his premises and instructed the servants to take the pump along with him. Benoist, Méricourt and Panzi were richly endowed with three large pieces of silk.¹⁵⁰⁵ The following year, Benoist died from a stroke just a few days before Hallerstein, who was twelve years his older. Panzi later painted the great emperor's portrait.¹⁵⁰⁶

We do not know the type of vacuum pump that Minister Bertin sent to the Chinese Emperor. At that time, Hauksbee's pumps from the beginning of the century still dominated. However, in 1721, Swedenborg¹⁵⁰⁷ assembled a new type of pump. He used a table with two tall legs holding a closed bell. The steel vessel was connected to a steel tube through which mercury poured.

In 1721, Swedenborg designed a new series of pumps that Žiga Zois studied in his enormous

books, which he had brought to Ljubljana. Dr. Joseph Knight Baader (* 1763; † 1825) used similar Swedenborg receptions in 1797 as a substitute for Marly's pumps in Versailles in 1806. The principle was used by Joseph Baader in his improved pump, followed by the Frenchmen Michel and Cazalet. Most of the contemporaries did not know Swedenborg's discovery, so Gren¹⁵⁰⁸ reprinted it and commented on it.¹⁵⁰⁹ In 1847, Strutt baron Rayleigh published a translation of Swedenborg's discussions under the title Principles of Chemistry in London, and ten years later Geissler in Bonn used Swedenborg's principle for pumping the first cathode-ray tubes.

So, Bertin could send to Beijing Parisian pump of Michele or Cazalet; but they were probably still a kind of novelty in 1772. Cazalet also reported on solidification of mercury in Bordeaux in 1779. The freemason Jean-André Cazalet (1753 Anglès-1825 Bordeaux) was a pharmacist in École centrale in Bordeaux where he taught physics and chemistry at the university in 1796 and 1819.

The well-deserved candidate for the Parisian authorship of the minister Bretin's Beijing packet was Jean-Antoine Nollet. In 1740, Nollet published on vacuum pumps and discussed them in his letter to other inventors of pumps like Jean Jallabert (1712-1768) in 1745 and to the physician-electrician François-Étienne Dutour de Salvert (1711 Bailleul (Nord)-1789 Riom) in 1746. Nollet preferred Dutour's simpler design of vacuum pump. Most of the vacuum pumps of that era were designed by the illustrations of later Nollet's textbooks.¹⁵¹⁰ Certainly, Musschenbroek's designs were also praised, as most of Musschenbroek's books were also translated in French language. Even as late as in the 1770s the instruments following Musschenbroek's design were still produced by Georg Friedrich Brander and his son-

¹⁵⁰⁵ Needham, Ling, 1959, 3: 451; Francis Burgeois (Bourgeois, Tch'au Tsuen-Sieu, Tsi-Ko, * 21. 3. 1723 Pulligny (Meurthe) v Loraine; SJ 17. 9. 1740 Nancy; † 29. 7. 1792 Beijing (Pfister, 1934, 926)) wrote to the father Duprez on 1. 11. 1773 or 29. 11. 1773 (unpublished, recueil de Zi-ka-wei, pages 37--41, 42 (Pfister, 1934, 948); Aimé-Martin, 1843, 4: 223--224; Benoist, letter to the unknown on 4. 11. 1773).

¹⁵⁰⁶ Amiot, 1943, 457.

¹⁵⁰⁷ Emanuel Swedenborg (Emmanuel Svedenborg, * 1688 Stockholm; † 1772 London).

¹⁵⁰⁸ Friedrich Albrecht Carl Gren (1760--1798).

¹⁵⁰⁹ Gren, 1791, 409--410.

¹⁵¹⁰ David M. Stewart Museum, Lewis Pyenson, Jean-François Gauvin, *The Art of Teaching Physics: The Eighteenth-century Demonstration Apparatus of Jean Antoine Nollet*. Les éditions du Septentrion, 2002, p. 57; Nollet. 1740, Mémoire qui sont propres aux expériences de l'air. Seconde partie, De la construction d'une nouvelle machine pneumatique de raréfaction à deux corps de pompes. *Memoires de l'Académie royale des sciences*, pp. 567-585

in-law Caspar Höschel (1744–1820) in Augsburg.¹⁵¹¹

Nicolas Thillaye (1709 near Lizieux-1784 Rouen) was a father of the heir of his manufacture Noël-Vincent Thillaye (1749 Rouen-1802 Val de la Haie), of a botanist Jacques-François-René and a physician Jean-Baptiste-Jacques. Nicolas Thillaye acquired royal privilege for his production of pumps. He published his manual for constructions of vacuum pumps in 1766.¹⁵¹² He was a well-deserved descendant of Pascal's merits in the same town of Rouen. His design might be the one which the minister Bertin passed to Beijing, except that Nicolas Thillaye manufactured his tools in Rouen and not in Paris which was the alleged source of the vacuum pump delivered to the Chinese Emperor in 1773.

The assistant to Jean-Charles chevalier de Borda (4 May 1733 – 19 February 1799) Étienne Lenoir (1744–1832) also manufactured scientific instruments including the repeating cycle for geodetic surveying in Paris.

As the French Minister Bertin sent a vacuum pump designed in Paris to Beijing, he may have consulted the later most important Parisian pump manufacturer Fortin,¹⁵¹³ a staff member of the Parisian office of lengths (Bureau des longitudes) established in 1795. By Lavoisier's initiative Fortin began experimenting on balloons and precise balances. In 1778 and 1779, he presented his own vacuum pump to the Parisian Academy, where he first used a double stroke in France. In 1784, he compiled a gas meter, and in 1788 very accurate

¹⁵¹¹ Anne C. van Helden, *The age of the air-pump, Tractrix*, 1991, 3: pp. 149-172, here pp. 165-166; Brander, *Kurze Beschreibung einer kleinen Luftpumpe oder Cabinet Antlia*, Augsburg: Eberhard Kletts sel. Wittib, 1774.

¹⁵¹² Nicolas Thillaye. *Manuel Nécessaire à ceux qui achètent la Machine Pneumatique, de la construction du sieur Nicolas Thillaye, Pompier privilégié du Roi, demeurant à Rouen; Contenant 1°. Des instructions pour démonter, remonter & entretenir en bon état lesdites machines. 2°. L'usage de cette pompe pneumatique, ou un recueil d'expériences choisies qu'on peut faire avec cet instrument, & à la suite de ce recueil, la description de la marmite de Papin simplifiée par le même auteur, la manière d'en faire usage; & en outre celle d'une nouvelle casserole, ainsi que d'une cafetière, l'une & l'autre portant son bain-marie, & le certificat d'approbation de MM. de l'Académie des sciences de Paris*, Rouen: Étienne-Vincent Machuel (1719-1781) rue S. Lo, vis-à-vis le Palais, 1766.

¹⁵¹³ Jean Nicolas Fortin (* 1750 Mouchy-la-ville (Oise); † 1831 Paris).

scales for Lavoisier. He invented a highly successful mobile barometer filled with mercury. After Lavoisier's execution, Fortin's laboratory was sold out on 10 November 1794. During the Empire, Fortin was involved in the production of scientific tools, and in 1806 he produced a gauge for exploring the expansion of air.

The Chinese emperor most likely got Nollet's or even Fortin's Parisian pump, designed for the needs of the Lavoisier's circle. Fortin's vacuum pump had two pumping mechanisms. They directed the chain with hooks, pushed in opposite directions by means of a lever. Both pistons were connected by Fortin to reduce the force required to overcome air pressure. The idea was developed earlier. Fortin linked both pistons as did Denis Papin (* 1647; † 1713), Francis Hauksbee (Hauksbee, Hawksbee, * 1660 Colchester; † 1713 London) and P. Musschenbroek's colleague Willem Jacob 'sGravesande (* 1688; † 1742). The Beijing missionaries equipped 'sGravesande's book with the proprietary entry of the Franciscan treasurer Alexandre de Gouvea (* 1731 Evora in Portugal; † 1808 Beijing), who was designated as the Bishop of Beijing in 1782.¹⁵¹⁴

Two inlet pipes originating from the pump body were merged into one, open in the middle of the horizontal plate for vacuum container. Pressure on the container was transmitted through the test tube on the side. It worked on a tube containing a "squeezed" siphon barometer with the same legs. The barometer measured small pressures by difference in mercury levels in both arms. The remaining pressure in the barometer can be measured with a vertical tube mounted on the second side opening, with the end immersed in a full mercury container. When the pressure in the vacuumed vessel decreases, the mercury in the tube rises. The pipe in front of the plate releases air into the container, which would otherwise be impossible due to air pressure. In the later version, a second barometer and a small lateral faucet were added to it, through which the gas was discharged into the previously prepared container.

Anyway, the Chinese Emperor was very fond of the French vacuum pump. François Bourgeois described the Peking experiments with the pump in a letter to the French Jesuit Duprez on November

¹⁵¹⁴ Verhaeren, 1969, 507-508; Pfister, 1934, 942.

1, 1773 and November 29, 1773.¹⁵¹⁵ Bourgeois' research of the Shanghai dialect was later published in Shanghai (1934, 1939); his work was probably sent to Paris together with Hallerstein's survey of Chinese population statistics by which Hallerstein shocked Europeans who figured out that the great stone nicknamed earth was not entirely theirs at all.

The vacuum pumping was not over for China after the Beijing era of Jesuits. The Vincentian (Lazarist) monk expert for vacuum pumps, magnetism and electricity Jean Joseph Ghislain (1751 Salles by Chimay in Habsburg Belgium-1812 Beijing) arrived in Beijing in 1785 following Amiot's recommendations of Vincentians (Lazarists). Amiot wished that Ghislain and his Vincentians could take over the Jesuitical heritage in Beijing. The Bishop of Beijing, Alessandro de Gouvea, invited Vincentians (Lazarists) to Macao in China. In 1811, the Chinese emperor expelled from Beijing all but three Portuguese Vincentians (Lazarists) who were members of the Bureau of Mathematics and the French Vincentian (Lazarist) Louis-Francois Lamiaux, who was the French interpreter at the court. Ghislain died in Beijing several months later anyway.

The Chinese have accepted the assumption of air pressure like Europeans did a century earlier after Torricelli's letter to Ricci, when most Jesuits preferred to read Aristotle's interpretation of their Belgian Jesuit of English genus Linus, or Nicolo Zucchi's (* 1586; † 1670) Jesuitical work *Nova de machinis philosophia* with antiperistasis and fear of emptiness.¹⁵¹⁶ As the Chinese got their vacuum pump after the European controversy about the reality of vacuum was more or less settled down, they had not much ideological problems while voids were never very strange to the people of China or India anyway. The Easterners certainly influenced all European ideas of infinitely smalls as even Guericke himself cited mainly from Kircher's description of the universe,¹⁵¹⁷ and he

quoted also Huygens, Keckermann and Valeriano Magni who all heard a lot about Fareast at their domestic European harbours.¹⁵¹⁸

The Calvinist Bartholomew Keckermann (* 1571/1573 Gdansk (Danzig); † 1609 Gdansk), despite his premature death, figured as a very important physicist.¹⁵¹⁹ The Beijing Jesuits afforded two (1649 and 1669) editions of Zucchi's book with the proprietary entry of the Hallerstein's house as the seat of Chinese province (Prou^{ae} Sinensis).¹⁵²⁰

Even Descartes and the profound admirer of the Chinese Leibniz rejected the Torricelli-Galilean vacuum. The Chinese Jesuits used Galileo's¹⁵²¹ works including the Italian edition published in 1718 in Florence, which was acquired by Hallerstein's friend, the Bishop of Nanjing Laimbeckhoven.¹⁵²² Also, Hallerstein read Torricelli's¹⁵²³ mathematical works with his comrades; they merely used the humanistic part of Leibniz's books,¹⁵²⁴ and numerous Descartes' books including *Optics and Geometry*.¹⁵²⁵ The Pekingese Jesuits tried to save some coins, so some of Galileo's works in their possessions were bound together with Philip Apian's *De utilitate trientis* (1586. Tübingen), Kepler's *Dioptrice* (1611), Giulio Cesare La Galla's (*Lagalla** 1570; † 1624) *De phenomenis in orbe lunae new telescopii usu* a D. Gallileo Gallileo (1612. Venetiis: Thomam Balionum), the Florentine Franciscus Sittius' (*Sizzi, Firenze-1618 Paris*) *anti-Galilean Dianoia astronomica* (1611. Venetiis: Peter Maria Bertan),¹⁵²⁶ A. Piccolomini's *peripatetic Parafraasi sopra le Mecnica d'Aristotle* (1582, Roma), and others. Hallerstein read even a suspicious Galileo's *Dialogue* (1632, Florence), but preferred the translation of Matthias Bernegger issued in 1635,¹⁵²⁷ because Hallerstein as the obedient guy feared to use the later forbidden Galileo's *Discorsi*.

¹⁵¹⁵ François Bourgeois (Burgeois, Tch'au Tsuen-Sieu, Tsi-Ko, * March 21, 1723 Pulligny (Meurthe) in Loraine; SJ September 17, 1740 Nancy; † July 29, 1792 Beijing (Pfister, 1934, 926, 948; *Recueil de Zi-ka-wei*, pp. 37-41, 42; Aimé-Martin, 1843, 4: 223-224; Benoist's letter to unnamed 4th November 1773; Needham, Ling, 1959, 3: 451; Bernard-Maitre, 1948, 155).

¹⁵¹⁶ Borisov, 2002, 651.

¹⁵¹⁷ Knobloch, 2003, 238, 244; Schimank, Guericke, 1968, 196.

¹⁵¹⁸ Schimank, Guericke, 1968, 195-197.

¹⁵¹⁹ Fredman, 1997, 311, 13, 315, 319-320, 325.

¹⁵²⁰ Verhaeren, 1969, 916.

¹⁵²¹ Verhaeren, 1969, 958-959.

¹⁵²² Bookplate : *Bispo de Nankin* (Verhaeren, 1969, 958).

¹⁵²³ Verhaeren, 1969, 2.

¹⁵²⁴ Verhaeren, 1969, 589-590.

¹⁵²⁵ Verhaeren, 1969, 62, 160, 416-418.

¹⁵²⁶ Verhaeren, 1969, 815.

¹⁵²⁷ Bookplate *Collegij Soc. Jesv Pekini* (No. 1656, Verhaeren, 1969, 482-483).

Sumitomo later used the Leiden Latin edition of Dialogue of 1641 in Japan.¹⁵²⁸

Hallerstein and Laimbeckhoven used the German edition of Bion's Mathematical School¹⁵²⁹ and Wolff's Elementa matheseos universae on their way to the Far East in (1732-1735);¹⁵³⁰ both contained a description of vacuum pumps and they were also very popular among the residents of Ljubljana.

14.3 Hallerstein's Vacuum Related Books and Tools

14.3.1 Introduction: Books also Like to Travel, Do they Not?

Tell me what you read, and I'll tell you who you are ... That ancient proverb certainly fit perfectly to Hallerstein, who has brought the reputation of Carniolan knowledge to the undisturbed, never exceeded highs of the Chinese Celestial Empire. Hallerstein brought over the seas to Beijing a Slovenian songbook of the priest Stržinar. Hallerstein used to be a Jesuit pupil in Ljubljana and Vienna, and, above all, a great descendant of the Jesuits of St. Francis Xavier (* 1506; † 1552).

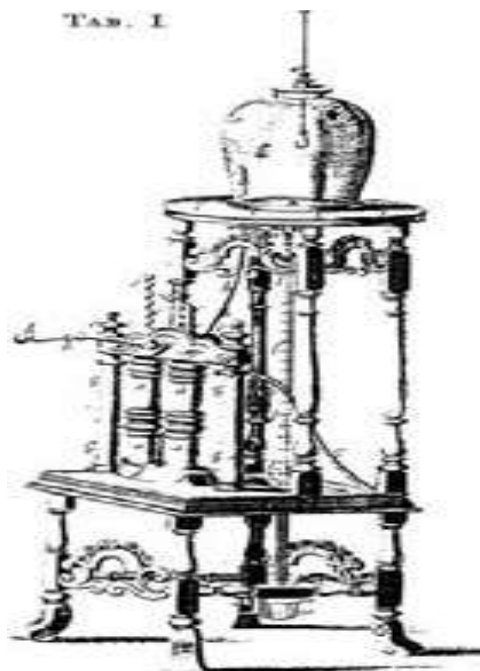

Figure 14-1: Hauksbee's vacuum pump from 1719 (Hauksbee, 1719, Tab X)

¹⁵²⁸ Yamazaki, 1952, 44; Sumitomo, 1963, 6.

¹⁵²⁹ Verhaeren, 1969, 1126-1127.

¹⁵³⁰ Verhaeren, 1969, 909.

Foreword to the songwriter Stržinar was written by Franc Mihael Paglovec (* 1679 Kamnik; † 1759 Spodnji Tuhinj). Unfortunately, Hallerstein did not record his personal inscription on a bookplate into that and other books, although his predecessors, the Jesuits in Beijing's leading positions, did that regularly.

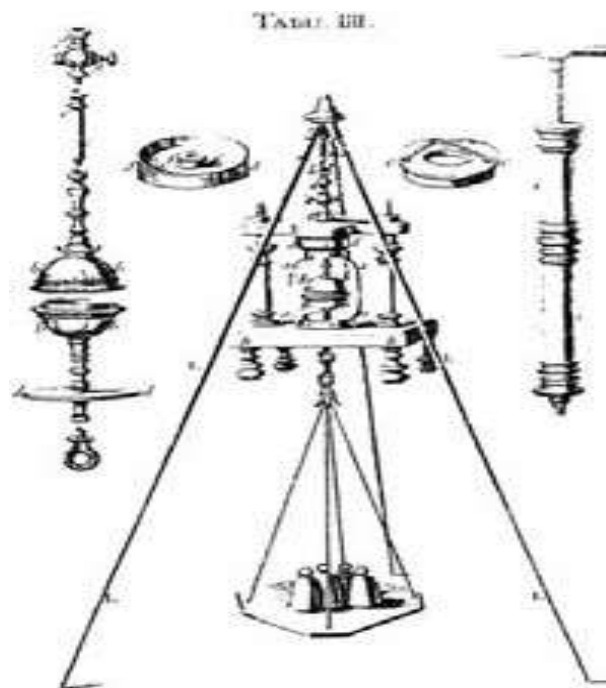

Figure 14-2: Hauksbee weighing of air pressure by the Magdeburg hemisphere of 1719 (Hauksbee, 1719, Tab III)

Hallerstein was the head of the Tongt'ang library in the second Beijing residence established under the Portuguese flag in 1655, half a century after the first Nant'ang library. It was founded by Ricci and was among the best of all Beijing missionaries' collections.¹⁵³¹ So, we have a lot of books with the proprietary entry of the Nant'ang library, often written as Nan-tâm. That certainly indicated Hallerstein's ownerships. Among Hallerstein's readings there were many gifts of Parisian scientists, as well as the legendary Boerhaave's collection of medical writings in the Venetian edition. Many Hallerstein's books had the seal of the respective bishop of Beijing, among whom only Jesuit Souza and Gouvea lived in the bishop's seat at Nant'ang headquarters near Hallerstein's residence.¹⁵³² For this reason, most Hallerstein's books have the bishopric own proprietary records. In the case of Souza, often only his name

¹⁵³¹ Verhaeren, 1969 *Catalogue*, p. VI.

¹⁵³² Verhaeren, 1996 *Catalogue*, p. XXII.

Polycarpe was used as a propriety entry. The first edition of London printed Smith's Optics from 1749 shows that the bishop handed the book to Hallerstein. Many Hallerstein's books had merely the mark of his collegium "Collegii S.J. Pekini" with the modern French works included.

After Hallerstein's death, all Chinese missionary libraries merged into a library of former French Jesuits called Pe-t'ang.¹⁵³³ Many mathematical works in the Latin language have the bookplates of Bishop Gouvea, who may have put them only afterwards, as he took over his bishopric only eight years after Hallerstein's death. Hallerstein's predecessors mentioned themselves as the Chinese vice-provincials and as Japanese provincials' dignitaries, but Hallerstein did not do that anymore, although he became vice-provincial and visitor of Japan in 1745. The Japanese Jesuitical books got their Japanese Jesuit propriety entries only prior to 1665, since the Jesuits have no longer been allowed to visit the Land of the Rising Sun after 1640.

Hallerstein published his highly detailed observations¹⁵³⁴ in important European metropolises. He never put his foot on the Japanese soil. Except for the foreigners of the Dutch Verenigde Oostindische Compagnie (VOC) on the artificial island of Deshima (Dejima, 出島) in the Nagasaki bay, no foreigners were permitted to put their anchor in Japan after 1640.¹⁵³⁵ Hallerstein has learned his science as assistant Ignatius Kögler and André Pereira (徐懋德, 1689–1743).¹⁵³⁶ He continued the development of the mathematics of the French Pekingese Jesuits Gerbillon, Bouvet, and Thomas¹⁵³⁷ by re-establishing co-operation between the two groups of Jesuit missionaries who worked under the flags of Portugal and France. Hallerstein was especially close to the French Jesuits Gaubil, d'Incarville and Amiot. If there has ever been a serious competition between the two groups, Hallerstein had abandoned it by the time when the sharing of scientific devices and the exchange of knowledge became increasingly

necessary for Beijing's Jesuits, while their core activity was inextricably shifting from religion to science in fatal decades before the ban of their Jesuit order.

Hallerstein has repeatedly tried to convince his European correspondents about his insufficient supply of astronomical and physical aids. In his own right, that was primarily a smart policy for acquiring better equipment, with which, as a conscientious observer, Hallerstein also earned his knowledges of natural phenomena. Hallerstein's European correspondents in London and elsewhere accepted his explanations, helped him and sent new devices and books for astronomical and other observations in a kind of exchange for Hallerstein's Chinese measurements.

14.3.2 *Hallerstein's Ljubljana Scientific Background*

The Magdeburg Mayor Otto Guericke sold one of his first pumps to Schönborn, who, as a prince and bishop, of course, was very wealthy; in Regensburg he was impressed by Guericke's experiment with horses, which in vain tried to separate the evacuated hemispheres. Even the emperor Ferdinand III was excited about the funny experiment of unsuccessful horses.¹⁵³⁸ After Ferdinand's death, Johann Philipp von Schönborn (* 1605; † 1673) played a key role in the election of his son, the emperor Leopold, under the influence of the Prince of Ljubljana Janez Vajkard Auersperg (Johann Weikhard Auersperg, * 11 March 1615, the town of Žužemberk; † 1677 Ljubljana), the informal first minister at the Viennese Court. Auersperg helped Guericke in his vacuum experiments,¹⁵³⁹ as Avgustin Hallerstein later read in Guericke's Amsterdam report of 1672 under his Beijing bookplate ownership noted as "Collegii Societatis Jesu Pekini".¹⁵⁴⁰ A. Hallerstein's mother, Susana Elizabeth, Baroness Erberg (* 1681 Ljubljana; † 1725) was the granddaughter of Auersperg customs official Lenart von Erberg (Leonard Verderber, * 1606; † 1691 Kočevje) from the Knežja Lipa in Kočevje areas, and therefore Hallerstein with even greater pride, read about the Auersperg's achievements; maybe Hallerstein liked it even more than we do today. Hallerstein became acquainted with vacuum

¹⁵³³ Verhaeren, 1996 *Catalogue*, p. XXVII-XXXIII

¹⁵³⁴ Lu, Shi, 2003 *Accuracy of Solar Eclipse Predictions*, p. 290.

¹⁵³⁵ Rinaldi, 2006 *The "Chinese Garden in Good Taste"*, p. 56.

¹⁵³⁶ Lu, 1999, 336.

¹⁵³⁷ Han, Jami, 2003 *The Circulation of Western Mathematics*, p. 156.

¹⁵³⁸ Slaby, 1906 *Otto von Guericke*, p. 9.

¹⁵³⁹ Guericke, 1986 *Neue "Magdeburgische" Versuche*, pp. 76-78.

¹⁵⁴⁰ Verhaeren, 1996 *Catalogue*, p. 516.

and electrical experiments already in his native city of Ljubljana, where the first prince Turjaški (Auersperg) spent his last years. Auersperg's associate Guericke closely linked his vacuum experiments with his invention of an electrified spinning ball of sulfur. The first prince of Auersperg was not only Guericke's "assistant", but also a great supporter of science; he had richly awarded the Roman Jesuit A. Kircher, who dedicated the chapter from his *Oedipus* to the prince; moreover, the prince gave a golden cup to the Protestant Johann Wilhelm Count Stubenberg (* 1619 Neustadt along the Mettau River in the east of the Bohemian Lands; † 24. 4. 1663 Kitzel in Hungary or 15. 3. 1663 Vienna) for his translation of F. Bacon's book.

Stubenberg devoted to the prince Auersperg the first German translation of Francis Bacon, a prophet of the modern-day growing importance of applied science and experiments. For this reason, Auersperg presented a splendid golden cup to Fruchtbringende Gesellschaft in 1657;¹⁵⁴¹ Stubenberg was its member under the imaginary sad name "Unhappy."

On his visits to Carniola and Bakar bay, Newton's patron Halley enjoyed the guiding of Hallerstein's father also in the time when Hallerstein was born in Ljubljana. With such an excellent base, Hallerstein had something to show to the Chinese Emperor for whom he worked in the second half of his life. Even before he threw out his anchor in Canton in September 1738, he learned all about the latest electric experiments of Stephen Gray (1729), Charles François de Cisternay Du Fay (1732) and Du Fay's protegee the Priest Jean Antoine Nollet, who later transformed into the main rival of Freemason Benjamin Franklin. Hallerstein paid close attention to the work of Cisternay Du Fay because of his name sounding like the Cistercian, as two of Hallerstein's younger brothers were successful Carniolan Cistercians: Abundius Hallerstein († 1768) proved to be amongst the best local Cistercians, and Alexander Hallerstein († 1804 Ljubljana) became the last abbot of the Kostanjevica monastery and witnessed the sad story of its abolition in 1786. The Chinese somehow accepted Hallerstein's astronomy including the electrical devices and vacuum pumps, as Hallerstein and colleagues in their Beijing libraries had three copies of the description

of the Jesuit vacuum balloon of Lana Terzi,¹⁵⁴² and they also read about Montgolfier's balloon. The Jesuit Hallerstein scanned the entire opus of Pascal,¹⁵⁴³ although the man was bitter against the Jesuits and ridiculed the quarrelsome Jesuit Étienne Noël.¹⁵⁴⁴ Hallerstein read the physics writings of Schott,¹⁵⁴⁵ Newton and Musschenbroek¹⁵⁴⁶ already in the library of his uncle Franz Michael Baron Erberg (* 1679; † 1760) in Ljubljana and Dol; there he liked to look at the barometric experiments of Laurentius Gobart (* 1656 Liège; † 1750 Liège) from 1716 and 1746, while Hallerstein also provided essentially the same reading in Beijing. Hallerstein has learned electrostatics and vacuum techniques already in Ljubljana, where his role model Auersperg has spent his final years. The first cousin of Hallerstein's mother, the Jesuit physicist of Ljubljana Bernard Ferdinand Erberg (* 1718 Ljubljana; † 1773 Krems), procured vacuum and electrical devices in 1755 at the latest, and at the same time the Brits, Dutchmen and Sanchez mailed them to Benjamin Franklin in Philadelphia,¹⁵⁴⁷ for Hallerstein to Beijing and for the Shogun to Edo (Tokyo). We discovered how Hallerstein and his Beijing colleagues tested vacuum and electricity and, above all, achieved enviable successes.

14.3.3 Beijing Experiments with Electricity

The magnets were the first love of Carniolan Hallerstein, since he already measured the compass

¹⁵⁴² Lana's books were decorated with the proprietary entry of the French Pekingese Jesuits "*PP Gallor SJ Pekin, Collegij Societatis Jesv Pekini, Veyo da Residencia de Cinanfu*" (Lana Terzi, *Magisterium*; Verhaeren, 1996 *Catalogue*, pp. 572-573) and with Hallerstein's "*Da Vice Provinciae da China da Compania de Jesus, Collegij Societatis Jesv Pekini, Vice Provinciae Sinesis*" (Francesco Lana Terzi, Prodomo, Brescia, 1670; Verhaeren, 1996 *Catalogue*, p. 971). The French Pekingese Jesuits also decorated reports of research on the vacuum in the mercury barometer of Torricelli's heirs at the Academy of Florence, edited by Count Lorenzo Magalotti (* 1637; † 1712) under the title *Saggi di naturali esperienze* (Verhaeren, 1996 *Catalogue*, p. 921 (No. 3136)). Equal Bookplates have Schott's books: *Magia universalis, Mechanica (1657) and Physica Curiosa* (Verhaeren, 1996 *Catalogue*, pp. 804-805 (Nos. 2717-2719)).

¹⁵⁴³ Verhaeren, 1996 *Catalogue*, p. 150.

¹⁵⁴⁴ Saito, *O Vácuo de Pascal*, p. 51.

¹⁵⁴⁵ Verhaeren, 1996 *Catalogue*, pp. 803-805.

¹⁵⁴⁶ Verhaeren, 1996 *Catalogue*, pp. 669-670.

¹⁵⁴⁷ Beaudreau, Finger, 2009 *Medical Electricity*, p. 98.

¹⁵⁴¹ Bircher, 1995 *The "splendid library"*, pp. 289, 297.

declination while navigating to the Far East. Later he completed his findings in Beijing,¹⁵⁴⁸ where they acquired the books about the Jesuitical theories of the magnets of Nicolo Cabeo (* 1586; † 1650) published in his *Philosophia magnetica*¹⁵⁴⁹ and the thoughts of the Chinese Flemish Jesuit Ferdinand Verbiest. They dominated over today's more conceivable assumptions of the doctor of British Queen, William Gilbert,¹⁵⁵⁰ although already the partner of Chinese Jesuit superior Nicolas Trigaut (* 1577; † 1628) Johann Schreck (Terence, Terrentius, * 1576 Constance; † 1630 Beijing) brought Gilbert's book *De Magnets* (1600) to Beijing.¹⁵⁵¹ By inscriptions on the bookplates, we can easily identify the books of other Jesuits in Beijing. Unfortunately, Hallerstein did not even enter his name in Stržinar's songbook,¹⁵⁵² although we could search with a candle on a white day for anyone other than him who could read it in Slovenian language in China. Certainly, some books from the once Jesuit Beijing libraries got their feet in the forthcoming century or came to the hands of less consecrated owners.¹⁵⁵³

In 1750, Hallerstein and his associates from the Portuguese college of St. Joseph in Beijing received an electric device, along with aids to observe the eclipses. The Jewish doctor Antonio-Nunes Ribeyra Sanchez (Ribeiro Sanches, * 1699

Penna-Macor; † 1783 Paris)¹⁵⁵⁴ obtained both those instruments with his friends in London and the Netherlands. In 1740, the designated Bishop of de Souza¹⁵⁵⁵ assisted in transport;¹⁵⁵⁶ for the time being we do not know for sure the type of Hallerstein electric machine, as we cannot be sure about the whereabouts of an electric device which Erberg bought five years later for the Jesuits of Ljubljana. It could probably also be a spindle producing its electrical power supply by friction after Guericke's invention, and not the Leyden jar, which Pieter Musschenbroek's invented in November 1745. The description of the novelty was published in January of the following year. Formerly a Leyden University student, Sanchez learned hourly about P. Musschenbroek's novelty, as he attended P. Musschenbroek's lectures at Leyden University. P. Musschenbroek's father and uncle established a shop for vacuum and electrical appliances right across the street. Sanchez regularly corresponded with Gerard van Swieten; Swieten's comments on their joint teacher, Boerhaave, were translated by the Japanese,¹⁵⁵⁷ while they were no less enthusiastically read by the Beijing Jesuits.¹⁵⁵⁸ Unfortunately, love was strongly unilateral, as both Swieten and his friend Sanchez soon deleted the Jesuits very badly.¹⁵⁵⁹

Even before Sanchez delighted Hallerstein with an electric device, the rich Quaker Peter Collinson (* 1694 Hugal Hall in northwest England; † 1768 London) sent a Leyden jar from the London royal society to Benjamin Franklin across the Atlantic. In 1751, Collinson arranged for the publication of their correspondence, which largely defined modern thinking about electricity and lightning rods.¹⁵⁶⁰ Sanchez also corresponded with Collinson; he sent him the seedlings of rhubarb, which he received from Hallerstein's Jesuits.¹⁵⁶¹

On October 25, 1753, Collinson sent a flower of mimosa to Hallerstein's good Beijing friend, the

¹⁵⁴⁸ Amiot et al, 1784 *Mémoires, concernant l'histoire* (2. October 1784), p. 563; Pfister, 1934 *Notices biographiques*, p. 760.

¹⁵⁴⁹ The Beijing edition does not have any Ex Libris, like the book of Cabeo *In quatuor libros meteorologicorum*. Ex Libris of the Chinese Jesuits Francisco Pereira and Martino Martini read as: *Applicado a Missao da China ou ao Collegio de Macao Fr. Francisco Pereira. Coimbra 1656 and Ad usum p. Martini. – aplicados a Igreja de Hâm Cheu* (Verhaeren, 1996 *Catalogue*, p. 336; Pfister, 1934 *Notices biographiques*, pp. 220, 256).

¹⁵⁵⁰ Guan, 2005 *The Historical Evolution*, p. 143.

¹⁵⁵¹ Ex Libris: *Bibl. Trig.* (Verhaeren, 1996 *Catalogue*, pp. 494-495).

¹⁵⁵² Bernard-Kilian Stumpf (* 1655 Wurzburg; † 1720 Peking) wrote his own Ex Libris: *Anno Kam Hi 56 luna 1^a, die 4^a Imp^l hunc librorum cum 10 aliis dono dedit P. Kiliano* in the book of Valeriano Bonvicino, *Matematiche discipline* published in Padua in 1665 and in 1666 (Verhaeren, 1996 *Catalogue*, pp. 938 (No. 3206) and used the form *P. Kiliano Stumpf. – Ex dono Pris Amiani ijn itinere Maccaensi. – Vice prov. Sinensis p. J. – Ad usum P.K.S.* in three copies of the Jesuit books of Casati (* 1617; † 1707): Casati, 1685 *Fabrica et uso del Compasso* (Verhaeren, 1996 *Catalogue*, pp. 944 (no. 3228)). Stumpf often saved ink and wrote a shorter Ex Libris *P.K.S.*

¹⁵⁵³ Walravens, 2001 *The Qiqi Tushuo revisited*, pp. 188.

¹⁵⁵⁴ Gaubil, 1970 *Correspondance de Pékin*, p. 617.

¹⁵⁵⁵ Polycarpe de Souza (Sou Tche-Neng Joei-Kong, * 1697 Coimbra; SJ 1712 Portugal; † 1757 Peking (Pfister, 1934 *Notices biographiques*, pp. 701)).

¹⁵⁵⁶ Gaubil, 1970 *Correspondance de Pékin*, pp. 703.

¹⁵⁵⁷ Goodman, 2000 *Japan and the Dutch*, pp. 177, 179.

¹⁵⁵⁸ Verhaeren, 1996 *Catalogue*, pp. 850, 851.

¹⁵⁵⁹ Korst, 2003 *Een doktet van formaat*, pp. 148, 224, 232, 234-235.

¹⁵⁶⁰ Beaudreau, Finger, 2009 *Medical Electricity*, pp. 98, 101.

¹⁵⁶¹ Chalmers, 1816 *The General Biographical Dictionary*, 27: 88; Gaubil, *Correspondance de Pékin*, pp. 37.

French watchman and the imperial gardener Pierre Noël Chéron d'Incarville (* 1706; † 1757).¹⁵⁶² On 2 November 1747, d'Incarville reported to the Parisian Bernard Jussieu (* 1699 Lyon; † 1777 Paris) that Hallerstein gave him Johann Schreck's herbarium *Plinius Indicus* with plants, minerals and animals harvested in nature at a happier age when the Ming's authorities allowed the Jesuits to move freely across China and neighboring countries. Gabriel Gruber's Jesuit relative the father Johann Gruber (* 1623; † 1680) described Schreck's book to Kircher, and Kircher summarized it in his book on China,¹⁵⁶³ which was read by everyone from Valvasor in Bogenšperk to Hallerstein in Beijing. Schreck created his own collection according to Hernandez's Mexican model as Galileo's colleague at dei Lincei's Roman academy where Schreck assisted its founder Federico Cesi (* 1585; † 1630) in the Roman publication of the Hernandez' Notes *Thesaurus Mexicanus*, published in 1651. Unfortunately, Schreck's collection which Hallerstein kept in secret after Kögler's death in March 1746 did not receive a similar fate in print and is now considered to be lost. Hallerstein was aware of Schreck's activity, since Kepler published Schreck's letter in his optics *Ad Vitellionem* in 1604, which Hallerstein inherited from the missionary Alexandre de Rhodes (* 1591; † 1660 Isfahan in Persia);¹⁵⁶⁴ unfortunately, the forger's mare is always barefooted, so that the first-ever connoisseur of the plants from all the continents, Schreck, poisoned himself with the vegetal weld

after his wrong fatal belief that it was a jasmine. Hallerstein allowed his friend d'Incarville to copy Schreck's herbarium for d'Incarville and Jussieu's use, so there once were at least three copies of Schreck's manuscript. D'Incarville sent the transcript to Jussieu in three letters dated in 1747, 1748, 1751; Jussieu handed the collection to Claude-Joseph Geffroy (* 1685 Paris; † 1752 Paris), who died before he was able to finish comparisons with previously-known European plants.¹⁵⁶⁵ In February 1746, Secretary of the London Royal Society Cromwell Mortimer asked the Chinese Jesuits to send him butterflies and their larvae; for this purpose, Hallerstein assigned his friend d'Incarville as the best Jesuit connoisseur of plants in the capital, as he reported to Mortimer in a letter dated September 18, 1750.¹⁵⁶⁶ Thus, Hallerstein has gained immense merits among biologists as well including his research on Siberian musk deer (*Moschus moschiferus*) published in London.

The leading Chinese European scientist Hallerstein also held his hand over the famous Beijing experiment with electricity, which is largely the basis of a modern electronically-oriented society. His associate from the French Jesuit College, Amiot, was also thrilled to experiment with electricity, but Hallerstein had much better equipment, as it was slightly jealously reported by Hallerstein's French Jesuit comrade, Gaubil.¹⁵⁶⁷ At that time Amiot, Hallerstein and Hallerstein's assistant Gogeisl measured the apparent height of the Gamma star in the constellation Andromeda for comparison with similar measurements carried out by Jesuit Pezenas¹⁵⁶⁸ and his two assistants in Marseilles.¹⁵⁶⁹

Beijing's electrophorus, described in the letter to the Petersburg Academy in conjunction with the invited competition academic prize, was an achievement of Hallerstein's social network, which was highly praised by the Russian academics in anticipation of new Beijing-based Jesuit electricity

¹⁵⁶² Rinaldi, 2006 *The "Chinese Garden in Good Taste"*, pp. 153, 159.

¹⁵⁶³ Kircher, 1667 *China monumentis*.

¹⁵⁶⁴ The Pekingese Jesuits had two heavily cited copies; one designated by Rhodes as his property in Macau: Alexi Rhauus J.C. D.M.Ch. (Verhaeren, 1996 Catalog, p. 557; Pfister, 1934 *Notices biographiques*, pp. 184-185), like that of the Venetian edition of the ancient Heron (Heron, *De gli automata*, Verhaeren, 1996 Catalog, p. 968). At the end of the year 1646 in Macao (Macau) the Pole Michel Boym (* 1612; † 1659), named "Miguel Polaco", was noted and immortalized in Kepler's tables (Kepler, *Tabulae Rudolphinae*) full of manuscript remarks with a inscription of the bookplate: *Da Livreria de Nant'am. – Memoriale ao p^e Procurador de Japon. Pede muyto o P Miguel Polaco que ste livro Tabulas Rudolphinas V R(es)idencia en Procuradoria e si o mesmo P^e Miguel Polaco ditto liuro pedira a P^e Joan Nicolao de China que o mande lae si ambos merveran que a appliqué pera Pekin porque he unico a optimo pera calcular as Eclipses Sol et Luna e movimentos dolle 1646. Decemb 2. Maccaj* (because he is the only one to calculate the eclipses of sun and moon with movements, Verhaeren, 1996 *Catalogue*, p. 559).

¹⁵⁶⁵ Bernard-Maitre, 1949 *Le Père Le Chéron d'Incarville*, pp. 25-27, 28; Pfister, *Notices biographiques*, pp. 154, 157; Iannaccone, *Johann Schreck Terrentius*, pp. 84-85; Kircher, *China monumentis*, pp. 110-111.

¹⁵⁶⁶ Hallerstein, 1753 *A Letter*, pp. 319-323; Bernard-Maitre, 1949 *Le Père Le Chéron d'Incarville*, pp. 29; Pray, 1781 *Imposturae CCXVIII*.

¹⁵⁶⁷ Hsia, 2009 *Sojourneus in a strange land*, pp. 4, 172.

¹⁵⁶⁸ Espirit Pezenas (* 1692 Avignon; SJ; † 1776 Avignon).

¹⁵⁶⁹ Gaubil, 1970 *Correspondance de Pékin*, pp. 840, 843, 850.

research. In 1755, the Pekingese Jesuits fused a thin glass plate and placed it on a compass glass cover so that the charging could be repeated several times. Each time the magnet needle rose again and returned to its original position in a few hours. When the Jesuits withdrew the previously-charged glass panel, the compass's magnetic needle rose again and remained in contact with the glass cover. When they returned their glass plate to its previous place, the needle dropped again. Thus, the Pekingese Jesuits could repeat the experiment many times.¹⁵⁷⁰ They were certainly not fully aware that for the first time in history in a controlled laboratory environment they observe a repeatable experiment with a permanent source of electricity, as we have been used in today's batteries or electrical outlets. But they were sufficiently self-conscious to report their success immediately to the Petersburg Academy, which soon accepted Hallerstein as its correspondent (foreign) member as the only Catholic of Slavic origins besides Bošković and Janez Žiga Valentin Popovič.

In November 1753, the Petersburg academy of science published a prize-winning question about the real causes of electricity and its theory, and the last day for mailing the answers was June 1, 1755.¹⁵⁷¹ The Russians were interested in both physical and chemical backgrounds of electrical phenomena.¹⁵⁷² We do not know whether the competing contribution of the Hallerstein's Jesuits came in time to Petersburg, but despite of all the praise they were not officially rewarded. According to the contributions of other competitors, it might be possible to say that the exploration of the Pekingese Jesuits was primarily a careful experimental observation, as was also typical of all Halletstein's contributions, while the winners of the competition also provided a more philosophical explanation of the background of electrical phenomena.

On September 6, 1755 the Russian Empress Elizabeth proclaimed the winners. The first prize (praemio coronato) was awarded by the academy to the son of the renowned academician Leonhard

Euler, the young Johan Albrecht Euler (* 1734; † 1800), for his *Disquisitio de causa physica electricitatis*. L. Euler's works naturally got the most prominent site of the Hallerstein's Library. The other two selected studies were created under the goose pen of the Barnabite monk Paul Frisi (* 1727; † 1784) from the University of Pisa¹⁵⁷³ and Lalande's Jesuit professor, director of the astronomical observatory in Lyon employed in 1740 Laurent Béraud's (* 1703 Lyon; † 1777 Lyon) *Physique des corps animés*. The victorious works of the triumphant trio were announced by the Academy in 1757, while the copy of their book was also noted among the collections of a Pekingese bishop Alexandre de Gouvea (* 1731 Evora in Portugal; † 1808 Beijing) in 1782; by his pleasant habit, he pressed his seal on the cover.¹⁵⁷⁴

The Beijing missionaries also obtained a later Frisi's study of electricity published in 1781,¹⁵⁷⁵ although Frisi opposed Bošković's Jesuitical Lombardian pedagogy. Frisi also participated in discussions on magic in the circles of Koper native Gian Rinaldo Carli, who became the leading Lombardian economist soon after the commission installed Bošković in then Habsburgian Pavia University. Carli wrote his introductory letter of his *Lettere Americane* to the freemason Benjamin Franklin, and the collection was printed in 1781 by Lorenzo Manini, another Freemason in Cremona.¹⁵⁷⁶ The electricity testing was thus extended from the Hallerstein's Pekingese Jesuit circles to the main fun of the European Freemasonry networks where it was advanced by Franklin's friend, the Parisian Freemason¹⁵⁷⁷ and Swieten's successor in the profitable position of personal physician of Maria Theresa, Jan Ingenhousz (Ingen Housz, * 1730 Breda in southern Netherlands; † 1799 Wiltshire). On his way to Florence in May 1769, Ingenhousz visited the provincial headquarters in Ljubljana and explained to the Carniolans of the benefits of vaccination against the smallpox.¹⁵⁷⁸ In the same year in 1769, Bošković and Franklin's friend, the Piarist Giacomo Battista Beccaria (Beccheria, * 1716 Mondovi; † 1781 Turin), reprinted a report on the electric experiments of Hallerstein and his

¹⁵⁷³ Frisi, 1755 *De existentia et motu aetheris*.

¹⁵⁷⁴ Verhaeren, 1969 *Catalogue*, pp. XXII, XXIII, 199;

Pfister, 1934 *Notices biographiques*, pp. 942, 1034.

¹⁵⁷⁵ Frisi, 1781 *Dei conduttori elettrici*; Verhaeren, 1996 *Catalogue*, pp. 958).

¹⁵⁷⁶ Trampus, 1997 »*Dottrina magica*«, pp. 149.

¹⁵⁷⁷ Hans, 1953 *UNESCO of the eighteenth century*, pp. 519.

¹⁵⁷⁸ Wiesner, 1905b *Jan Ingen-Housz in Wien*, pp. 208.

¹⁵⁷⁰ Aepinus, 1979 *Aepinus's Essay on the Theory of Electricity*, pp. 130.

¹⁵⁷¹ *in veram electricitatis causam, veramque ejus condatur theoria* (Euler, Frisi, Béraud, 1755 *Dissertationes selectae*, 1: 3-4, 10).

¹⁵⁷² Euler, Frisi, Béraud, *Dissertationes selectae*, 1: 8.

companions interpreted by Franc Aepinus.¹⁵⁷⁹ Beccaria offered a satisfying explanation; Beccaria was initially very close to the young Alexandro Volta and led him to his new discoveries that enlightened the world. Literally, by electric lighting.

14.3.4 *Hallerstein's Vacuum-related Books*

The bookshelf is the most important mirror of the human soul. This is especially true for astronomers. Since we do not yet have the portrait of most important Carniolan astronomer Avguštin Hallerstein, we can see at least the contents of his books on the anniversary of his pilgrimage to China, where he soon climbed into the very top of Chinese astronomy. He never returned to Europe, and his absence was outweighed by his published works in all major European centers.

The Beijing bishop Gouvea often provided enough early entry dated propriety entries, but Gouvea himself came to Beijing too late to directly cooperate with the nearly three decades older Hallerstein. That is why we will limit our listing of Hallerstein's books to those works that Hallerstein certainly used shortly after their printouts. They were marked by the ex libris of his college in Beijing, but some books, unfortunately, were left without a bookplate.

Among old books from Hallerstein's library were Claude Rabuel's (* 1669 Pont-de-Veyle; SJ 1685; † 1728 Lyon) Lyon comments on Descartes's geometry and Jean Jacques d'Ortous de Mairan's interpretation of the northern light (Aurora Borealis). Both books got the bookplate of the Hallerstein's Beijing College in 1739, a few months after Hallerstein's arrival in China on September 1, 1738. After Hallerstein settled in Beijing on March 1, 1739, maybe he himself marked the ownership record in both those books. Mairan's work, which Hallerstein had read only six years after the Parisian print, was especially useful to Hallerstein during his own observation of the northern light (Aurora Borealis) in Beijing on 17 September 1770, which Hallerstein described for a publication of his friend Hell in Vienna a year and

a half later.¹⁵⁸⁰ Mairan was a close Bošković's associate and briefly secretary of the Parisian Academy. Unfortunately, Hallerstein, by his very nature, confined itself only to the observation of the northern light without any possible theoretical interpretations; so, he did not cite Mairan's nor Bošković's papers about the northern lights, although he must have known them. In 1733, Hallerstein's Viennese associate Maximilian Hell and four decades later the former Ljubljana rector Anton Ambschell still accepted the Cartesian belief that the northern lights is due to the reflection of the solar and even the lunar (mirrored) light on ice particles under the horizon; we can think that Hallerstein could not be too far from their opinion. The autumnal 16th-18th September 1770 Northern Lights besides Hallerstein, also Hebei province observers, the Japanese, and Hell also afforded to observed. It became certainly the most famous in all Auroras in history when it appeared after long decades of absence of these phenomena; the Captain J. Cook, as the first, watched it with modern scientific preparations on the southern hemisphere and proved that the southern hemisphere aurora australis also had similar colors as the aurora borealis had on the north.¹⁵⁸¹

Hallerstein began to read the professor of mathematics Rabuel's critique of Descartes's geometry nine years after its publication. He echoed the Jesuit controversy of those years when even a physical fight between the Cartesians and their opponents broke out at the Zagreb college; it was only calmed down by a strict intervention by the Jesuitical authorities. Four years before the publication of Rabuel's book in Lyon, just before Hallerstein started teaching rhetoric in Ljubljana, the Italian professor of physics Anton Terzi of Gorizia, with the help of the professor of logic Josip Novoselić from Varaždin publicly defended theses in 1726 and appealed to General Tamburini reject Descartes' presumption on accidents that should remain in the Eucharist. Descartes' ideas were advocated by the professor of metaphysics Luka Bakranin; Terzi and Novoselić criticized him with the help of his own students.

Bakranin entered Cartesian networks during his studies in Graz and in Vienna; he did not hide his Cartesian views horses when he became professor of philosophy in Zagreb in 1723. The dispute stirred the whole city. By the intervention of the

¹⁵⁷⁹ Beccaria, 1769 *Experimenta, atque observationes*, pp. 44-47; Heilbron, 1979 *Electricity*, pp. 405-410.

¹⁵⁸⁰ Hallerstein, 1772 *Lucis borealis Pekini*, p. 251.

¹⁵⁸¹ Ambschell, 1807 *Elementa Physicae*, 2: 128-129.

Austrian provincial Maximilian Galler the Jesuitical general Michelangelo Tamburini tempered the unfortunate inconvenience by scolding both sides. Terzi (Tertia) was rejected by noting that Descartes's works had not yet been placed on the list of prohibited doctrines in official index on 15 June 1706. The clever general of the Jesuits recalled that Bakranin had asked him earlier to go to the missions; after the dispute in Zagreb, of course, he granted his request mercifully. Unfortunately, the poor Bakranin died while waiting for a boat in Cadiz.¹⁵⁸² He was born in Oštarije 20 km south of the White Carniolan border while his surname suggested his connections with Bakar bay forty km west of his native place.

In the meantime Hallerstein replaced the very painfully ill and next spring deceased Kögler, In 1745, Hallerstein wrote the ownership record of his college in the seven years old astronomical and physical work of Joseph Nicolas Delisle (d'Isle, Lisle, * 1688 Paris; † 1768) which Delisle personally donated to him before returning from the long-standing Petersburg astronomical service to his native Paris. In 1749, Hallerstein, now officially anchored at the highest scientific position possibly filled by a foreigner in Beijing, acquired the most prominent optical work of his time, the eleven-year-old London publication of Robert Smith (* 1689; † 1768), which was also read by the Jesuits of Ljubljana. Hallerstein's book was acquired in the Nant'ang College by the Jesuitical Beijing bishop of Polycarpe de Souza. Gabriel Gruber, the first Ljubljana teacher of astronomical observations, bought Smith's optics in Pzenas' French translation from 1767 with the addition of Bošković's description of achromatic lenses; in 1772 Gruber entered a characteristic property registration of his department "Zur Mechanic"¹⁵⁸³ in the book in Ljubljana. Much later, the wealthy Sumitomo in Japan preferred the German translation of Smith from the pen of Gruber's teacher Abraham Gotthelf Kästner (* 1719; † 1800), which was published in 1755.¹⁵⁸⁴ L. Euler was, of course, the main source of Hallerstein's astronomy and related disciplines. Therefore, in

1745, the Russian Academy gave to Hallerstein two L. Euler's books about motions and music. Undoubtedly, they served him very much even if he did not read the other two Eulerian pearls owned by the Bishop Gouvea later.

The Neapolitan Jesuit Nicola Gianpriamo personally donated his astronomical textbook to Hallerstein and the Beijing Jesuits in 1748. According to the year of Dian-Griam's death, we can assume that a kindly gift was carried out shortly after the publication of the book; as an astronomer, of course, Hallerstein used the book with pleasure. Hallerstein was undoubtedly regularly reader of the Parisian Academic Bulletin, as were his Beijing neighbors under the French flag. Hallerstein's knowledge of French language was not the best, but it was enough for reading; he was especially pleased with volume containing the article under the pen of his French comrade d'Incarville from 1755, which Hallerstein's companions labeled as the property of his Beijing college called Nant'ang in that same year.

The Parisian pocket physical manual of the Jesuit Aimé Henri Paulian (* 1722; SJ; † 1801) of 1760 does not have proprietary entries, but it was probably also included as the everyday reference tool at Hallerstein desk. The bishop Gouvea later had the same work besides Paulian's adaptation of La Caille's mathematical papers, and many other La Caille's astronomical works.

Lalande's astronomy from 1771 was brought to Beijing at a time when Hallerstein's powers were waning; that book too was left without a proprietary entry. Lalande's works were, of course, read much by his French Jesuit fellows in Beijing. Lalande's ephemeris was even collected by the Beijing bishop Gouvea. Of course, the leading freemason Lalande may have been relatively far from Hallerstein's view of the world, but in their approaches to astronomy they were soon close enough. Lalande's Parisian Masonic Lodge the Four Sisters (Neuf Seurs) also had a greater impact on the inhabitants of the Habsburg monarchy with Slovenes included, as among its members was the imperial personal physician Ingenhousz,¹⁵⁸⁵ as well as his friend and co-worker in the expert in exploration of gases and getters, Felice Fontana, who joined the Habsburgian court of Florence as a

¹⁵⁸² Caraman, 1990 *Misija Paragvaj*, p. 299; Vanino, 1987

Isusovci, p. 150-152.

¹⁵⁸³ NUK-8456.

¹⁵⁸⁴ Sumitomo, 1957 *A classified catalogue of old books*, p. 4; Sumitomo, 1963-1964 *A classified catalogue of the books on science and technology*, p. 9, 75.

¹⁵⁸⁵ Conley, Brewer-Anderson, 1997, 277; van Doren, 1953, 519.

Table 14-1: Books on astronomical and related matters from the former Pe-t'ang missionary library, once read by the Bishop of Beijing, the Franciscan Alexandre de Gouvea (* 1731 Evora in Portugal; † 1808 Beijing); we chose those that were issued during Hallerstein's life

Author	Title	Place: Publisher	Year	Additional bookplate next to seal of Mgr. Alex. de Gouvea	Verhaeren, <i>Catalogue</i>, p.
Wilson, John	<i>Principia trigonometriæ</i>	Leiden: Peter van de Aa	1718	/	906
Musschenbroek	Elementa Physicæ	Leiden: Samuel Luchtman	1734	seal of Sousa- Sancheza	669-670
Heilbronner, Johann Christoph (* 1706?; † 1747)	Historiæ matheseos universa e mundo condito ad seculam P.C.N. XVI..	Leipzig: Joh. Frideric Gledic	1742	/	524
Willem Jacob 'sGravesande (* 1688; † 1742)	Physica elementa mathematica	Leiden: Verbeek	1742	/	507-508
Euler, Leonhard	Theoria motuum planetarum et cometarum	Berlin: Ambrosi Haude	1744	/	456
Euler, Leonhard	Introductio in analysin infinitorum	Lausanne: Marco- Michael Bousquet & Socios	1748	Para ovzo de Fr. Alexandre Guevea	454
Bion, Nicolas	L'usage des Globes	Paris: Guerin	1751	/	31
Saverien, Alexandre (* 1720; † 1805)	Dictionaire universel de mathematique et de physique. 1-2.	Paris: Jombert	1753	/	173
Seligny, Guillaume de	Nouveau zodiaque, Réduit à l'année 1755	Paris: Imprimerie Royale	1755	– Pertence à Livreria de Nant'am em Pekim (Pequim, Beijing)	174
Paulian, Aimé Henri (* 1722; SJ; † 1801)	Dictionaire de physique portatif	Paris: Girard	1760	/	150
Musschenbroek	Elementa Physicæ	Venetia: Remondi	1761	/	669-670
La Caille, Nicolas Louis	Ephémérides	Paris: Hérissant	1745- 1755,	/	74

de			1755-1765		
La Caille, Nicolas Louis de	Leçons élémentaires de mécanique	Paris: Desaint	1764	/	102
La Caille, Nicolas Louis de	Leçons élémentaires d'optique	Paris: Desaint	1764	/	102
Paulian, Aimé Henri; La Caille, Nicolas Louis de	La guide des jeunes mathématiciens	Paris: Libraires associés	1765	/	153
Pézenas, Espirit (* 1692; SJ; † 1776)	Astronomie des marins	Avignon: Girard/ Marseille: Mossi	1766	/	153
Lamy, Bernard (* 1640; OR; † 1715)	Enterteines sur les sciences	Lyon: Ponthus	1768	/	108
L'Hospital	Analyse des infiniment petites	Avignon: Girard & Seguin	1768	/	118

Table 14-2: Books on astronomical and other exact science topics from the former Pe-t'ang missionary Beijing library, which was once read by Hallerstein. The works published during his lifetime were arranged by the time of printing

Author	Title	Place: Publisher	Year	bookplate	Source: Verhaeren, Catalog, p.
Flamsteed, John (* 1646; † 1719)	Historia coelestis Britannica	London: H. Meere	1725	Collegium Pek. (volume 2)	468-469
Gregory, David (* 1661; † 1708)	Astronomae physicae & geometricae elementa	Deneva: Marco-Michael Bosquet et Socios	1726	Polycarpus Episcopus Pekinensis	511
Rabuel, Claude (* 1669; SJ; † 1728)	Commentaires sur la Geometrie de M. Descartes	Lyon: Marcellin Duplain	1730	Collegij Societatis Pekini A. C. 1739	160
Mairan, Jean Jacques d'Ortous de	Traité physique et historique de l'aurore boréale	Paris: Imprimerie royale	1733	Collegii S.J. Pekini A. C. 1739	127
Euler, Leonhard	Mecanica sive Motus scientia	Petersburg: Academia Scientiarum	1736	Nân-t'âm Collegij S.J. Pekinj donô ipsius Academiae 1745	455
Delisle, Joseph Nicolas (d'Isle, Lisle, * 1688 Paris; † 1768)	Mémoires pour server... l'astronomie	Petersburg: Academie des Sciences	1738	Nan-tâm Collegij S. J. Pekinj dono ipsus Academiae 1745	119-120 (wrong year 1638)
Smith, Robert (*	A compleat system	London: Austen	1738	Polycarpus	1201

1689; † 1768)	of opticks	& Dodsley		Episcopus Pekinensis Donavit Coll ^o Soc. Jes. Pekin, anno 1749	
Euler, Leonhard	Tentamen nova theoriae musicae	Petersburg: Academia Scientiarum	1739	Nân-t'âm Collegij S.J. Pekinj donô ipsius Academiae 1745	456
Marinoni, Giovanni Giacomo (* 1676; † * 1755 Vienna)	De Astronomia	Vienna: Kaliwoda	1745	/	Verhaeren, 1969, 636- 637
Gianpriamo, Nicola (* 1686; SJ; † 1759)	Specula Parthenopaea uranophilis juvenibus excitata.	Napoli: Seraphin Porsile	1748	Pro bibliotheca Collegii Pekinensis Societatis Iesu, ex dono Authoris	492
D'Incariville, Mariotte, Huygens, Picard, Bessy...	Mémoires de l'Académie	Paris: Imprimerie Royale	1666- 1755	Nan-tam Colleg S.J. Pekini 1755 – the coat of arms of French king Louis	2-6
Paulian, Aimé Henri (* 1722; SJ; † 1801)	Dictionaire de physique portatif	Paris: Girard	1760	/	150
Lalande	Astronomie	Paris: Desaint	1771	/	107

Table 14-3: Astronomical and theological books that Hallerstein and Laimbeckhoven took with them on their way to China

Author	Title	Location: Publisher	Year	Bookplate	Source: Verhaeren, Catalogue, p._
Fournier, Georg	Georgii Fournier geographica orbis notitia, per litora maris & ripas fluviorum	Paris: Apud Joannem Menault	1649	/	1630, 1631 (No. 304, 305)
Dechaes, Claude François Millet	Cursus seu mundus mathematicus, 1-3	Leiden: Anissini	1674	Veyo da Residencia de Cinanfu; <i>second copy</i> : Coll Pek.S.J.	364-365
Bion	L'usage des Globes	Paris: Boudot	1699	/	31
Bion	L'usage des Globes	Paris: Boudot	1699	Veyo da Residencia de Cinanfu	31
Bion	Astrolabes	Paris: Boudot	1702	/	30
Bion	L'usage des Globes	Paris: Boudot	1703	/	30
Bion	Instrumentes	Paris: Boudot	1709	/	30
Bion	Instrumentes	Paris: Ronder	1716	/	30
Bion, Nicolas	Neu=eröffnete Mathematische Werck=Schule... Doppelmayr	Nürnberg: Peter Conrad Monath	1726	/	1126-1127
Stržinar, Ahacij (* 1676; † 1741)	Kershanskega Vuka peissme	Graz: Widmanstand	1729	/	1203 (No. 4096)
Wolff, Christian	Elementa matheseos universae	Geneva: Bousquet	1732- 1735	/	909 (No. 3102 and no. 3103)

teacher of physics of the sons of the later emperor Leopold II.¹⁵⁸⁶ Bošković's friend Franklin was, of course, one of the key personalities of Lalande's Lodge, and he benevolently showed himself at the ceremony of accepting the elderly Voltaire on 7 April 1778.¹⁵⁸⁷

By the travel notes of his companion and friend Gottfried-Xavier Laimbeckhoven (Nan Hoai-Jen Ngo-Te, * 9. 1702 Vienna, SJ 27. 1. 1722 Vienna; † 22. 5. 1787 Tangjiaxiang by Songjiang east of Shanghai (T'ang-kia-hiang pi Su-choua) in China), we proved that Hallerstein brought to China at least the books of Claude François Millet Dechales (* 1621 Chambéry 100 km east of Lyon; SJ 1636; † 28. 3. 1678 Turin),¹⁵⁸⁸ Georg Fournier (* 1595 Caen; SJ; † 13. 4. 1652 La Flèche), Christian Wolff (* 24. 1. 1679 Breslau; † 9. 4. 1754) and Nicolas Bion (* 1652; † 1735). Unfortunately, the recent inventory of the former Beijing missionary library does not say anything conclusive about the fate of these books of both loyal comrades, Hallerstein and Laimbeckhoven. So, we do not know for sure where these works were kept later. They were published in folio formats, most of all Bion's encyclopedically-oriented treatment of mathematical and astronomical measuring devices. It is likely that the pathetic youngsters loaded earlier versions of Bion in their travel bags; that Parisian maker of mathematical devices was so popular in Ljubljana that Žiga's younger brother Karel Zois chose his work even as an ad ligate to his final exam at the University of Graz soon after Hallerstein's death. To the publications from the time of Hallerstein's life, we also added Stržinar's songbook, which does not have any astronomical pretensions, but it offered a tremendous amount of consolation to the great astronomer in the nights when the astronomical measurements did not come entirely as expected.

The Jesuitical naturalized Parisian Georges Fournier did not exactly love the Roman astronomers; nevertheless he praised Kircher's early measurements of the lunar eclipse of August 28, 1635.¹⁵⁸⁹ Even before he began to read Fournier's *Geography in Beijing*, Hallerstein

certainly saw it together with other Fournier's works in the Ljubljana library of the princes of Auersperg who used to be the masters of the ancestors of Hallerstein's mother, the noble baroness Erberg.

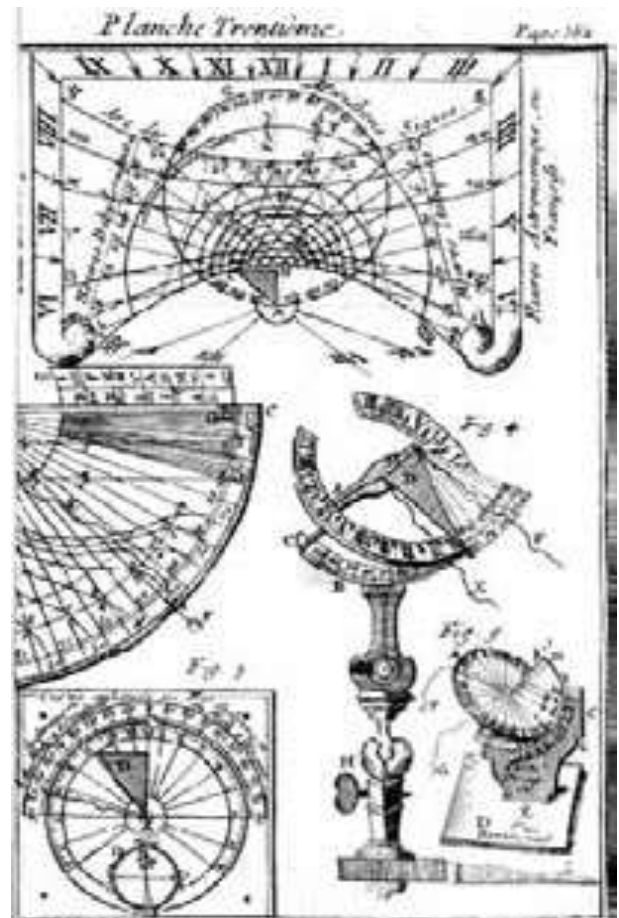

Figure 14-3: Gnomons in Bion's *Descriptions of Mathematical Devices* (Bion, 1752, 338 (Plate 32))

The Chinese Jesuits used Galileo's works¹⁵⁹⁰ up to the Florentine Italian edition of 1718, purchased by Hallerstein's friend, the Bishop of Nanjing Laimbeckhoven.¹⁵⁹¹ Of course, Galileo was formally the antagonist of most Jesuits; but the different views of the world never hindered Hallerstein's use of Galilean astronomical and physical knowledge. The seemingly strict Papal bans were increasingly weakened by the distance from the eternal Rome.

The French Jesuit Claude François Millet Dechales (* 1621 Chambéry; SJ; † 1678 Turin) in his *Cursus* considered the researches of light of Mersenne and Maurolyco.¹⁵⁹² Bouguer's *Traité* was published

¹⁵⁸⁶ Wiesner, 1905a *Jan Ingen-Housz Sein Leben*, p. 37;

Hans, *UNESCO of the eighteenth century*, p. 521.

¹⁵⁸⁷ Hans, 1953 *UNESCO of the eighteenth century*, p. 516.

¹⁵⁸⁸ Laimbeckhoven, *Neue umständliche Reiss-Beschreibung*, p. 71.

¹⁵⁸⁹ Fletcher, 1986 *Kircher and Astronomy*, p. 133.

¹⁵⁹⁰ Verhaeren, 1996 *Catalogue*, p. 958-959.

¹⁵⁹¹ Bookplate of the bishop: *Bispo de Nankin* (Verhaeren, 1996 *Catalogue*, p. 958).

¹⁵⁹² DiLaura, Lambert, 2001 *Lambert*, pp. LXV.

barely in the aftermath of 1760 with a famous sketch of a photometer, resembling Dechales's drawing in *Cursus* from 1690.¹⁵⁹³ The Chinese Jesuits afforded both Dechales's editions with his critical remarks at the expense of contemporaries; they were printed in Lyon in 1674 and 1690, and they were greeted with the proprietary entry of the Chinese provincial in Beijing; Hallerstein himself added to his many duties the honor of the Chinese vice-provincial in 1745. Hallerstein and Laimbeckhoven used Dechales' manual as a guide to triangulation during their sailing to the Far East. They probably loaded a newer edition from 1690,¹⁵⁹⁴ while Hallerstein, as a student and teacher in Ljubljana, used the older first print of 1674; the Jesuits of Ljubljana entered their *ex libris* into it as early as 1678.¹⁵⁹⁵ Dechales' manual is today the oldest preserved once-Jesuits' book in NUK with dated bookplate eventually connected with the year of purchase; Hallerstein read it already during his studies in Ljubljana and then during his teaching in the Carniolan capital. Dechales published, among other things, useful tables of logarithms up to 10,000, which facilitated Hallerstein's painstaking prolonged astronomical calculations.

Hallerstein and Laimbeckhoven also brought with them to China the German edition of the Bion's *School of Mathematics* from 1726,¹⁵⁹⁶ and Wolff's *General Cosmology* in many new volumes printed between 1732-1735; both books did not lack any descriptions of astronomical devices, vacuum pumps and other modern devices. Wolff's *General Cosmology*¹⁵⁹⁷ had a proprietary record of Hallerstein's colleagues Kögler, Andre Pereyra and Karl Slaviček in the library of the Beijing College

¹⁵⁹³ DiLaura, Lambert, 2001 *Lambert*, pp. XXVII, LXXII; LXXV.

¹⁵⁹⁴ The Bookplate Coll. Peck. S.J. can be found in the edition of the year 1674, with the bookplate : *Applicado to V. Provincia da China. - Vice Provinciae Sinesis* and in a later edition from in the year 1690 (Verhaeren, 1996 *Catalogue*, p. 364-365; Laimbeckhoven, 1740 *Neue umstandliche Reiss-Beschreibung*, p. 71).

¹⁵⁹⁵ Today kept as NUK-4209; After the fire, the book was catalogued among the saved Jesuitical books in the census *Verseeichnis* (1775) no. 431 (NUK manuscript 31/83).

¹⁵⁹⁶ Verhaeren, 1996 *Catalogue*, pp. 1126-1127.

¹⁵⁹⁷ Wolff, 1731 *Cosmographia Generalis* (propriety entry: *Reverendis Patribus Ignatio Koeglero Tribunalis Mathematici Praesidi, Andreae Pereyrae Carolo Slavicek p. J. Missionariis in Collegio Occidentali Lusitanica D. D. C. Theophilus Sigefridus Bayer Regiomontanus, Academicus Petropolitanus* (Verhaeren, 1996 *Catalogue*, p. 909 (no. 3100).

as a gift from the Petersburg Academy. It was brought to Beijing by the leading Russian academician of German descent Teophil (Gottlieb) Siegfried Bayer (* 1694 Bohemian Lands; SJ; † 1738 Petersburg) upon his visit to the Russian Beijing mission.¹⁵⁹⁸ Bayer was a correspondent of Hallerstein's French associate Dominique Parrenin (Parrenin, Pa To-ming K'e-an, * 1. 9. 1665 Grand-Russey; SJ 1. 9. 1685; † 20. 9. 1741 Beijing).¹⁵⁹⁹ According to the year of publication and Bayer's death seven years after the print, Wolff's work was placed in the Hallerstein College Library just before Hallerstein's arrival. In his domestic college, Hallerstein read another famous Wolff's work, the *Fundamentals of General Mathematics* in two different editions.¹⁶⁰⁰ Hallerstein and Laimbeckhoven used one of these two Wolff's textbooks of *Basics of General Mathematics* during their sailing in the Far East, beginning with their stay in the port of Lisbon on 24 April 1736; we assume that they have afforded the latest edition to bring as much as possible modern news for their Chinese hosts. Wolff's *Element or Compendium* from 1743 and 1744 were kept at the Ljubljana lyceum and in the library of Cistercians in Stična. The Ljubljana lyceum also had the printout issued in 1776. In them, Wolff considered trigonometry as the third chapter of mathematics after for arithmetic and geometry. At the end of his trigonometry, he briefly described the logarithms with which Neper and Briggs translated the multiplications and divisions to the additions and subtractions even for sinuses and tangents. Wolff also described the logarithms of ordinary numbers and provided the table for them.¹⁶⁰¹

Hallerstein has, of course, already learned all about Wolff's works in his domestic Carniolan headquarters. In the late Baroque, the Franciscans of Novo Mesto (New City) taught along Leibniz's guidelines; for this purpose, they bought many Wolff and Sturm's works including their adaptation

¹⁵⁹⁸ Martzloff, 2000 *Les activités scientifiques*, pp. 315; Viegas, *Ribeiro Sanchez*, p. 257-259.

¹⁵⁹⁹ Sommervogel, 1890-1900 *Bibliothèque de le Compagnie de Jésus*, 6: 284, 9: 757; Pfister, *Notices biographiques*, pp. 501-517.

¹⁶⁰⁰ Wolff, *Elementa matheseos universae* (printing of 1717 noted in: Verhaeren, 1996 *Catalogue*, p. 909 (no. 3101); printing 1732-1735 noted in: Verhaeren, 1996 *Catalogue*, pp. 909 (nos. 3102 and 3103), 25 cm, 4th volumes, missing last volume 4. The volumes 1-3 were bind in two separate books including 24 plates with figures, and, 88 diagrams)

¹⁶⁰¹ Wolff, 1758 *Compendium elementarum matheseos universae* 1758, p. 212-213.

of Desing. Even in the Hallerstein's Jesuit school library in Ljubljana, Wolff's mathematical works prevailed; five of them were recorded a year after a fire which harmed the old Jesuitical library in 1774.

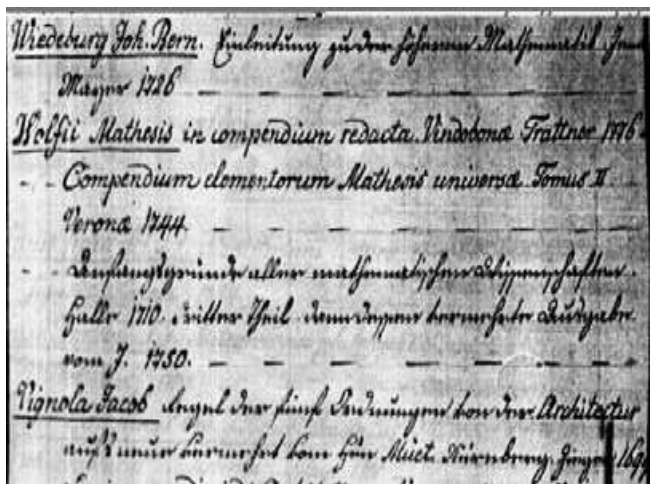

Figure 14-4: Wilde's Lyceum books Census (1800) showing Wolff's Compendium of 1744, which also Hallerstein afforded in Beijing.

Hallerstein was keenly impressed by Wolff's explanations already while reading the books of the Jesuits of Ljubljana, even more so on visits the private library of his maternal uncle Erberg. The libraries were, of course, linked closely as the Jesuit College of Ljubljana and its books were largely led by Hallerstein's relatives, mathematicians, astronomers and physicists of the family Erberg. Hallerstein's uncle baron Erberg classified many Wolff works from his Jesuitical Ljubljana library into a mathematical class, in which he also put the astronomical books. At least some of these Wolff's textbooks were examined by the student Hallerstein and then again while he taught in Ljubljana:

1718. Ratio praelectionum Wolfianarum in mathesin, et philosophiam universam. Halle / Magdeburg. 8°.

1725. Anfangsgründe aller Mathematischen Wissenschaften. Frankfurt. 1-4. 8°.

1711. *Logarithmic Tables* (Tabulae sinuum atque tangentium tam naturalium, quam artificialium una cum logarithmis). Halle / Magdeburg. 8°.

1711. Zu der Trigonometrie ... Halle: In Rengerichter Buchhandlung. 8o.

1747. Elementa matheseos universae. Halle / Magdeburg. 5 parts.

1748. Lucas Opfermann (1690 Fulda-1750 Fulda, Jesuitical professor of mathematics in Wurzburg); Adam Adolph Schöpfflein (1704-1753, military architect in Wurzburg), Criticism of Wolff: Wolfius male vindicatur, sive Confutatio Scripti infamis, quod ab Anonymo compositum, Author ... D. Adamus Adolphus Schöpfflein ... typis excudi curavit, sub titulo: Vindicae Christiani Wolfi, oppositae dissertationi mathematicae: in qua examinantur: An elementa matheseos Christiani Wolfii sola & abunde satisfaciant & etc... Augustae et Wirceburgi: Veith. 8°.

1709. Vernünfftige Gedancken von den Wirkungen der Natur. 4 parts. Halle / Magdeburg. 8°. ¹⁶⁰²

Hallerstein, as a genuine Slovenian mountains' son, in his traveler bag brought Stržinar's songbook to Beijing. For many decades that book comforted and consoled him as the sole chorus of the Slovenian word far around. Two centuries later, a Beijing librarian the Lazarist Verhaeren mistakenly placed it among Polish books¹⁶⁰³ in simple ignorance, since the Slovene language was an unknown foreign language for poor Verhaeren. The reading of Stržinar's rhymes is at the same time the most beautiful proof of Hallerstein's Slavic linguistic abilities. Even if Hallerstein surname has some German connotations, Hallerstein remained the devoted Slovenian also among the Chinese far from his birthplace.

Boerhaave's collected medical works from 1757 have an explicit note as bookplate of the Hallerstein College of Peking, since Hallerstein liked to look in it for medicines explicitly noted for his health problems. Swieten was, of course, the most important scientist in the Hallerstein homeland, the Habsburg Monarchy. Nevertheless, the Beijing whereabouts of Swieten's comments on the work of Swieten's teacher Boerhaave is less certain; its older Venice print of 1746 does not have a proprietary entry, but there is also no proprietary entry in Stržinar's songbook, which had been Hallerstein's faithful companion until his last busy hour.

Hallerstein's friend d'Incarville was an important supporter of Linnaeus; the Viennese edition of the Linnaeus system was relatively late, and

¹⁶⁰² Lind, 1992 *Physik im Lehrbuch*.

¹⁶⁰³ Verhaeren, 1996 *Catalogue*, p. 1203.

Hallerstein could read the earlier prints of Linnaeus's works¹⁶⁰⁴ in the headquarters of the French Jesuits. Hallerstein's contribution to the botanical sciences of Linnaeus's sorts was of utmost importance, although we have just recently presented it to the Slovene public.

14.4 Habsburg-Slovenian Vacuum for the Far East

Only a few Jesuit missionaries from the Habsburg monarchy worked in China; they were very influential anyway. From the Austrian Jesuit Province, the Czech Václav Pantaleon Kirwitzer, Koffler, Johannes Gruber, Diestel, Herdtrich, Fridelli, Messari (Mesar), Joseph Chrysostom Neugebauer, Laimbeckhoven and Hallerstein traveled successively in China. Diestel, Mesar and Hallerstein were Carniolans, while Andrew Wolfgang Koffler was teaching Rhetoric in Ljubljana just before he sailed to the Far East. One of the most important Chinese missionaries was the Tyrolean Martino Martini, but Tyrol with Trident, Innsbruck and Hall was part of the Upper German Jesuit province.

Thus, the Carniolan guys contributed a substantial part of the Chinese missionaries from the Habsburg monarchy. Koffler and Martini went to the East before Torricelli's and Viviani's pioneering vacuum experiment, but Martini temporarily returned to Europe from 1650 to 1658 to research both Italian and German achievements. J. Gruber's traveling companion Vipava native Bernard Diestel studied physics at the University of Graz in 1643/44, when Torricelli wrote his famous letter to Ricci on the first barometer.

14.5 Early Japanese Vacuum Techniques

14.5.1 Introduction

Guericke sold one of his first pumps to Schönborn, who, as a prince and bishop, of course, had enough money; in Regensburg they impressed him with horses, which in vain separated the evacuated hemispheres. Even Ferdinand III talked about the experiment with enthusiasm. Johann Philipp von

Schönborn (* 1605; † 1673), after Ferdinand's death, played a key role in the election of his son, Emperor Leopold. Those novelties gradually spread worldwide as the Chinese have somehow accepted Hallerstein's astronomy and the novelties about the vacuum pump.

14.5.2 *The Dutch Science Travels to the Habsburg Monarchy (1713-1795) and to Japan (1720-1853)*

The Catholic part of the Netherlands, in the approximate borders of modern Belgium and Luxemburg, belonged to Habsburg monarchy. Luxemburg, belonged to Habsburg monarchy from the peace in Utrecht (July 13, 1713) until the French invasion (1795). At that time, the Belgian scientists, mostly after the study at Boerhaave's class in Leyden, exported Dutch science to a somewhat backward Habsburg monarchy. At the same era, translators from the Dutch language named Rangaku arranged that science for Japanese after the partial release of Japanese imports of books in 1720. Thus, the Musschenbroek's Leyden vacuum technique was approximately simultaneously established among the Japanese as among the Slovenes.

Dutch physician the Freemason Ingenhousz transferred vacuum techniques to Vienna, and his compatriots did the same thing in Japan through the Deshima Island in Nagasaki Bay. Before 10th and again on 20th August-9th September 1772, in the then Habsburg Firenze Ingenhousz vaccinated against the smallpox the family of archduke, the later Emperor Leopold; in Galileo's city, he was hanging out with his friend Felice Fontana,¹⁶⁰⁵ On his way back to Vienna until 28th in May 1769 he visited the provincial centers of Trieste, Gorizia, Ljubljana, Klagenfurt and Graz and explained there to the local surgeons and physicians the benefits of vaccination against the smallpox.¹⁶⁰⁶

Fontana allowed Ingenhousz to describe the invention of Fontana after Ingenhousz returned from Vienna to England in 1782.¹⁶⁰⁷ Ingenhousz used a vacuumed vessel with a copper and brass

¹⁶⁰⁵ Wiesner, 1905a, 37.

¹⁶⁰⁶ Wiesner, 1905b, 208.

¹⁶⁰⁷ Wiesner, 1905a, 72, 197; Ingenhousz, 1787, 197-198, 200, 228.

¹⁶⁰⁴ Verhaeren, 1996 *Catalogue*, p. 600.

Priest **Felice Fontana** (Felix, * April 15, 1730 Pomarolo near Rovereto in Tyrol near Rhône-Alpes, † 11. 1. 1805 Florence) never preached unlike his brother the Piarist mathematician Gregorio. Felice studied in Verona and Pavia. Then he lectured at the University of Pisa, where he became a professor of physics in 1766. He became famous enough; so, the Tuscan Archduke Leopold appointed him as director of the Physical and Natural History Museum in Florence. In 1772, Felice Fontana discovered the adsorption of gases by the heated wood needed for charcoal burning. He stopped the combustions of charcoal and at the same time prevented the outflow of the outside air to maintain the adsorption power of charcoal; later, he placed it in a vacuum receiver to absorb undesired air there. The count Marsilio Landriani (* 1751 Milano; † 1827 Vienna) described Fontana's discovery to J. Priestley, who repeated the experiment in 1775,¹⁶⁰⁸ but both Ingenhousz and Bošković were in heavy quarrels with Priestley. The Swedish expert Scheele (* 1742; † 1786 Köping) as one of the discoverers of oxygen successfully set the experiment for Scandinavians in 1773, while Bryan Higgins (Bryan, * 1737? Sligo in Ireland; † 1820) also confirmed Fontana's discovery for the great benefit of vacuum techniques in 1776. Priestley attended B. Higgins lectures and bought some tools from him, but they later quarreled, as B. Higgins soon also became estranged from his nephew William Higgins who first enunciated the law of multiple proportions. Fontana even thought that his charcoal could adsorb the volume of air that exceeded its own volume by six times;¹⁶⁰⁹ he performed the tests in a mercury barometer with a tube of 35 inches long. He filled about 10 inches of length with measured volume of ordinary air, hydrogen, nitrogen or oxygen to be able to observe changes in the adsorption power of charcoal. He measured the additional amount of matter that he withdrew from the already emptied space to reduce its density by his experiments with nitrogen.¹⁶¹⁰

give the due praise to Ingenhousz's doubts. Fontana's method of getting was prepared for the technical analysis of gas mixtures using a hand-held eudiometer in a procedure resembling Cavendish's experiments. At the same time, he improved Fontana's oxygen inhalation device,¹⁶¹² later used by Thomas Beddoes in Bristol¹⁶¹³ in the merry company of Žiga Zois's friend H. Davy. In 1771, Felice Fontana and Ingenhousz wrote about scientific devices and plans for the establishment of Academy of Sciences in Florence.¹⁶¹⁴

After studying at Boerhaave's class in Leyden, **Jan Ingenhousz** (Ingen Housz, * 1730 Breda in the south of the Netherlands; † 6. 9. 1999 Wiltshire) happily accepted the invitation of Maria Theresa to become her personal physician. Later, he somewhat regretted that decision because he felt trapped in Vienna and could not travel without permission. So, he asked his friend Benjamin Franklin to plan his leave for America although in 1775 he married Agatha Maria Jacquin (* 1735), the sister of the famous Viennese professor of botanic baron Nicholas Jacquin; or maybe just because of that? Ingenhousz discovered photosynthesis, and he designed many vacuum and electrostatic experiments for the study of various gases. During his trip from Vienna to Florence he also visited Carniolan places).

Ingenhousz returned to Vienna after three years of travel. He mostly stayed in Fontana's Florence.¹⁶¹⁵ As soon as he recovered from a clumsy journey along the badly paved roads, he built a double-piston vacuum pump in Vienna using Fontana's discovery of charcoal getter's absorption. That kind of research was later highly appreciated by Ernst Mach,¹⁶¹⁶ who often visited his parents under Gorjanci in Lower Carniola (Dolenjska). Ingenhousz used a powder mixed with olive oil to hermetically seal the vacuumed vessel;¹⁶¹⁷ he

cap. He did not fully endorse Fontana's hopes that his getter of charcoal exhausts a better vacuum than ordinary pumps.¹⁶¹¹ Today, you might just

¹⁶⁰⁸ Fontana, 1783, 72-73.

¹⁶⁰⁹ Fontana, 1783, 78.

¹⁶¹⁰ Fontana, 1783, 79-81.

¹⁶¹¹ Ingenhousz, 1784, 445-446.

¹⁶¹² Wiesner, 1905a, 197, 208.

¹⁶¹³ Wiesner, 1905a, 210.

¹⁶¹⁴ Wiesner, 1905a, 197, 229.

¹⁶¹⁵ Ingenhousz, 1784, 435.

¹⁶¹⁶ Wiesner, 1905a, 190; Ingenhousz, 1784, 431-446.

¹⁶¹⁷ Ingenhousz, 1784, 441.

Table 14-4: Wolff's works in the libraries of Cistercians in Stična and Franciscans in Novo mesto.

Author	Title, Place: Publisher	Year	Language
Wolff, Christian	<i>Elementa matheseos universa</i> . Geneve: Gosse (Stična, cited in NUK-Ms. 21/83 99 ^v)	1743 (1744)	L
Wolff, Christian	Mathematischen Wissenschaften. Frankfurt: Renger	1701	N
Wolff, Christian	Wirkungen der Natur = Physica. Halle: Renger	1746	N
Wolff, Christian	<i>Elementa matheseos</i> . Vindobonae: Trattner	1774	L
Wolff, Christian	Arithmetica, Geometria. Vindobonae: Trattner	1766/1782	L
Desing, Anselm	Replica Pro Clarissimo viro Abrahamo Gotthelff Kaestnero Matth. P.P.E. Acadd. Regg. Sc. Suec. & Pruss. Institut. Bonon. Sac. Reg. Sc. Gott. Membro, Super Methodo Wolffiana scientifica aut mathematica. Augustae: Gastl	1754	L

Table 14-5: Mathematical and astronomical books of the Hallerstein era with dated bookplates of the Jesuits of Ljubljana, which Hallerstein also kept in his Beijing Library

Year of Purchase	Aged upon Purchase for the College of Ljubljana	Writer	Language (translation from)	Reference code in NUK
1674	4	Dechales	Lat.	4209
1752	60	Lana Terzi	Lat.	8461 (2 parts)
1756	6	Wolff	German	4136 (2 parts)
1750-1758	11	Wolff	Lat.	4049 (2 parts)
1754	25	Musschenbroek	Lat. (Dutch)	8458
1754	5	Parisian Academics	German (Fr.)	8361 (2 parts)
1754	14	Magalotti	It.	2303
1768	22	Euler	Lat.	8185
1754	12	Doppelmayr	Lat.	10575

Table 14-6: Books outside the mathematical sciences' group relevant for Hallerstein's botany at the former missionary Beijing library Pe-t'ang (North Church, Beitang, 北堂) which Hallerstein used in his time in his Portuguese Dongtang (Tongt'ang, 東堂, East Church, residence of St. Joseph) and Nant'ang (Nantang, 南堂, South Church) college libraries

Author	Title	Place: Publisher	Year	Proprietary entry	Source: Verhaeren, Catalog, p._
Swieten, baron Gerard (* 1700; † 1772)	Commentaria in Hermani Boerhave	Venezia: Jo. Baptistae Pasquali	1746	/	850
Swieten, baron Gerard	Commentaria in Hermani Boerhave	Leiden: Johann & Hermann Verbeek	1749-1755	Iste Liber pertinet ad bibliothecam Stephani Johannidis Nobilissimi Domini De Pace Ducis Tervia-schow. Anno 1780 Junii 20 die	851
Boerhaave, Herman (* 1668)	Opera omnia medica	Venezia: Laurent Basili	1757	Da Livra de Nantàm a Pekim	304
Linnaeus	Systema Naturae	Vienna: Joanis Thomae de Trattner	1767-1770	Seal of Mgr Alex de Gouvea	600

Table 14-7: Academic ancestors of the Habsburg-Chinese Jesuits

Name	In China	The first five generations of academic ancestors born outside of the Austrian province (according to specialization in vacuum-technical sciences)	The first 5 generations of academic ancestors born in the Austrian province
Kirwitzer	1620–1642	7 (64 %)	4
Koffler	1645–1652	16 (70 %)	7
Martino Martini	1637–1650 1658–1661	1 (20 %)	4
Johannes Gruber	1658–1661	10 (77 %)	6
Diestel	1658–1660	6 (100 %)	0
Herdtrich	1660–1684	17 (63 %)	10
Fridelli	1705–1743	6 (46 %)/4 (32 %)	7/15
Mesar (Messari)	1707–1714	11 (50 %)	11
Neugebauer	1739–1743 1750–1759	0	0
Laimbeckhoven	1739–1787	1 (6 %)/1 (8 %)	17/12
Hallerstein	1739–1774	1	17/12

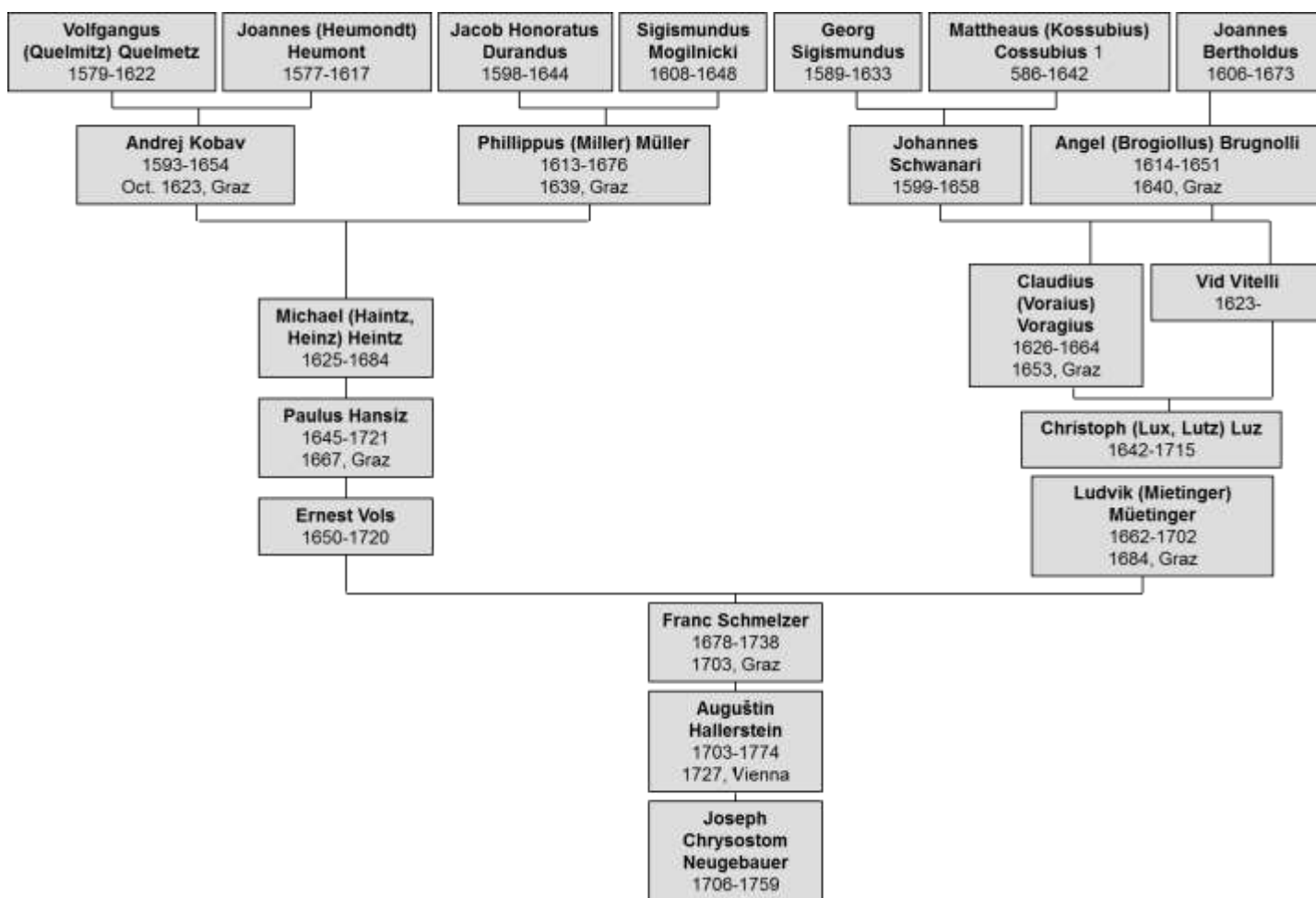

Figure 14-5: Five generations of the academic ancestors of the Carniolan baron Hallerstein, who was among the most meritorious teachers of European vacuum experiments at the Chinese imperial court

painted the whole device,¹⁶¹⁸ and at the same time its parts.¹⁶¹⁹ Hallerstein's friends among the Viennese Jesuits were not invited to experiments except the Jesuit numismatist and mathematician Josef Khell von Khellburg with whom Ingenhousz corresponded on June 20, 1772.¹⁶²⁰ Hallerstein nevertheless learned about Ingenhousz's successes through his Viennese comrades who gathered around the editor of Hallerstein's works, the Slovak Jesuit Maximilian Hell. Thus, Hallerstein knew all about the puzzles of vacuum at a time when his colleagues, the French Jesuits, presented a vacuum pump to the Chinese Emperor on March 10, 1773.

14.5.3 Rangaku (伊學), Erekiteru (エレキ, エレキテル), and Vacuum Pumps in Japan

The transfer of Western books which discussed vacuum to Japan began with the Jesuits, who, after being expelled from Japan, transferred their main precious books across the sea to China. These books still have their Japanese proprietary inscriptions, but they should not be confused with the ownership entries of the Chinese Jesuits with Hallerstein included, who still retained their official titles of the Japanese provincials and visitors, although their journey to Japan had been already banned for some time.

Among the most important Japanese libraries were the books collected by the family of owners of copper mines Sumitomo. The beginnings of their book collection probably go back to the time of the beginner of the family upswing Masatomo Sumitomo (住友政友, * 1585 Fakui north of Kyoto; † 1652), who designed his shop of medicines and books in Kyoto in 1630. Last but not completely least, the books were purchased by his adopted son Tomomochi Sumitomo (Riemon, * 1607; † 1662), who studied mining in Deshima to help with copper mining in the company of his father Riemon Soga (* 1572; † 1636). Riemon founded the company Izumiya in 1590; he successfully married Masamoto's older sister and learned Western procedures for obtaining copper and silver from minerals.¹⁶²¹ In 1904, Kichizaemon VI Sumitomo Tomoito (住友吉左衛門, * 1865; †

1926), the fifteenth heir of the Sumitomo family, founded the library in his hometown Osaka, and two decades later, he donated to it his own valuable collection including his hundred and fifty rare old books. The library is now named Nakanoshima in the Prefecture of Osaka.

It's not clear when Sumitomo family acquired individual items among the books in the spreadsheet, probably they got them more as antiquarian curiosities in early 20th century. However, it is assumed that the electric Erekiteru in experiments and the vacuum techniques described in them soon became well-known to the curious Japanese. Sumitomo family did not purchase early vacuum studies of Huygens, Guericke, Boyle, Pascal, Kircher or Schott, as only got Huygens's later collections (1905).¹⁶²² Of course, Sumitomo's family bought much less Jesuit works compared to Hallerstein's Beijing missionaries; however, Sumitomo had Bošković's *De micrometri* Objectives published in Karl Scherffer's Viennese Latin translation of optics by Nicolas Louis de Lacaille (* 1713 Rumigny; † 1762 Paris) from 1757/1758 and Benvenuti's *Optica* published according to Bošković's order in one of the later Viennese editions.¹⁶²³ Sumitomo's library did not have many Dutch rangaku works which were considered obsolete in Japan of the late 19th century, although the Leyden editions prevailed, including books of Borelli and Musschenbroek.

Sumitomo family did not acquire Agricola's works on the foundations of mining, and had only a few mining papers published before the Hallerstein's death. Of course, they read the work of the beginner of modern mining using vacuum techniques, the Bolivian Alvaro Alonso Barba (* 1569 Lepe in southwest Spain; † 1662 Potosi in then Spanish Peru, now part of Bolivia), who earned his bread as a parish priest in Tarabuco and St. Bernards within the mining area of Colombia. Barba discovered amalgamation as a process of heating the gold, silver and copper ore in saline solution of mercury. He cooked in his copper vessels until he cleaned out enough pure metal. Barba's first Spanish edition was published in 1640, and the jealous Spaniards hid it

¹⁶¹⁸ Ingenhousz, 1784, 450-451 (Tab. II), in fig. VIX.

¹⁶¹⁹ Ingenhousz, 1784, 451 in Tab. II, fig. VIII, IX, X.

¹⁶²⁰ Wiesner, 1905, 225.

¹⁶²¹ Sumitomo, 1979, 6, 9.

¹⁶²² Sumitomo, 1963, 44.

¹⁶²³ Sumitomo, 1963, 4, 73; not in Yamazaki, 1952.

Table 14-8: Kichizaemon VI Sumitomo's former books about vacuum techniques and related fields printed before Hallerstein's death.

Pet'ang Library in Beijing has the same book, has other edition of the same author, has other books of the same author, does not have such books	Field	Year	Indication in Osaka, 1962 or Yamazaki, 1952
<i>Giovanni Alfonso Borelli</i> (* 1608; † 1679)	Mechanics- De vi Percussionis	1586	42; 1: 4, 173
<i>Guidobaldo del Monte</i> (Guido Ubaldo Montis, * 1545; † 1607)	Mechanics- Italian translation	1615	48; 1: 57
<i>Galileo</i>	Astronomy- <i>Dialogus</i>	1641	1: 160
<i>Pierre Varignon</i> (* 1654; † 1722)	Mechanics- <i>Pesanteur</i>	1690	48
<i>Jacques Rohault</i> (* 1620; † 1675)	Physica	1718	1: 11, 48; 47
	Optics in Amsterdam edition	1720	47
<i>Bouguer</i>	Optics- photometry	1729	42
<i>Musschenbroek</i>	Latin <i>Institutiones</i> and French <i>Essai</i>	1748, 1751	1; 11, 4; 46
Dalham	Viennese physics of monks Piarists	1753	1: 5, 37; 43
Nollet	Electricity in French and Italian editions	1754, 1755	1: 11, 86; 47
<i>Lacaille</i> ; Bošković	Lectiones Elementaires d'Optique	1758	1: 73
Benvenuti, Carlo (* 1716; SJ; † 1789); Bošković, Rudjer Josip	Dissertatio physica de lumine. Vienna: Trattner	1761	1 : 73
<i>Euler</i>	Mechanics-Theoria motus	1765	44
Priestley	Electricity in History-German Edition	1769	1: 87
Priestley	Optics in History-German Edition	1776	1: 77
Volta	Letters of Fermentable Gases obtained from Moors	1778	1: 4, 89; 48

Table 14-9: Kichizaemon VI Sumitomo's books on mining technologies published in Hallerstein's era

Author	Area of research	Year	listed in Osaka, 1962 or Yamazaki, 1952
The surgeon from Gotha David Kellner (* 1643; † 1725)	Mining	1702	1: 9, 291
Albrecht von Haller's brother-in-law Hermann Friedrich Teichmeyer (* 1685; † 1746)	Salt	1749	1: 13, 182
Barba ¹⁶²⁴	Mining	1729	1: 292
Urban Friderick Benedict Brückmann (* 1728; † 1812)	Precious stones	1757	1: 166
Johann Christoph Adelung's revue in Leipzig	Mineralogische Belustigungen, zum Behuf der Chymie und Naturgeschichte des Mineralreichs	1768-1771	1: 11, 167
Johann Gottlieb Kern († 1775?)	Mining	1772	42
Sven Rinman (* 1720; † 1792)	History of steel	1785	1: 12, 168
Franz Ludwig von Cancrin (* 1738; † 1812)	Blast furnaces dedicated to the Russian Emperor Catherine (Ekaterina) ¹⁶²⁵	1788	1: 299
The surgeon William Richardson	Mining	1790	2: 294

¹⁶²⁴ Sumitomo, 2: 293.

¹⁶²⁵ Sumitomo, 2: 299.

harshly, which does not mean that the early Sumitomo did not learn the basic features of Barba's discoveries. The other Spanish edition of 1729 was enthusiastically translated; Nicolas Lenglet Dufresnoy (* 1674; † 1755) translated it to the French language in 1751 under his penname Gosford. The Dutch edition appeared in 1740, while the Viennese Freemason Trattner published Matthias Godar's translation in 1749 and 1755. Barba considered salt mines,¹⁶²⁶ and the formation of rocks,¹⁶²⁷ especially these precious ones;¹⁶²⁸



Figure 14-6: Parts of Barba's vessels needed for his amalgamation painted in his Metallurgy from the Sumitomo's Library (Barba, 1729, 166).

then he began his main goal, the metallurgy.¹⁶²⁹ Of course, his metals were connected to the planets;¹⁶³⁰ he painted his blast-furnace.¹⁶³¹ He discussed the sympathies and repulsion between individual metals¹⁶³² cast into special containers¹⁶³³

¹⁶²⁶ Barba, 1729, 11.
¹⁶²⁷ Barba, 1729, 19.
¹⁶²⁸ Barba, 1729, 21.
¹⁶²⁹ Barba, 1729, 29.
¹⁶³⁰ Barba, 1729, 37.
¹⁶³¹ Barba, 1729, 99, 130, 134, 137, 139.
¹⁶³² Barba, 1729, 102.
¹⁶³³ Barba, 1729, 107, 166, 184.



Figure 14-7: Blast furnaces and metal discharging vessels in Barba's Metallurgy from the Sumitomo's Library (Barba, 1729, 184).

through the roofs of the blast furnaces.¹⁶³⁴ He was also interested in the healing power of metals,¹⁶³⁵ and he used special vessels for the precious metals of platinum and gold.¹⁶³⁶ He published tables on the rudimentary properties of ores in Peru,¹⁶³⁷ which was, of course, an additional reason why the Spaniards jealously hid first issues of Barba's books. In the second edition, the Spanish editor included the treatment of the mines of Alonso Carrillo y Lasos (* 1582-?; † 1628 Córdoba),¹⁶³⁸ which added data on the Spanish domestic mines in the Pyrenees¹⁶³⁹ and the surroundings already in the Roman times.¹⁶⁴⁰ Barba used Paracelsus¹⁶⁴¹ and Galileo's work on Jupiter's satellites as possible new planets. Of course, Galileo's assumptions undermined the ancient scheme of the number of planets in relation to the number of metals.¹⁶⁴² Juan de Andosilla of Colegio Imperial

¹⁶³⁴ Barba, 1729, 116.
¹⁶³⁵ Barba, 1729, 119.
¹⁶³⁶ Barba, 1729, 125.
¹⁶³⁷ Barba, 1729, 141.
¹⁶³⁸ Barba, 1729, 195.
¹⁶³⁹ Barba, 1729, 199.
¹⁶⁴⁰ Barba, 1729, 208.
¹⁶⁴¹ Barnadas, 1986, 71.
¹⁶⁴² Barnadas, 1986, 72; Barba, 1729, 38.

de Madrid examined Barba's discoveries,¹⁶⁴³ followed by the Spanish royal cosmographer Christian Rieger (* 1714 Vienna; † 1780 Vienna) in 1763;¹⁶⁴⁴ Rieger later became rector of the Jesuitcollege in Ljubljana where his knowhow of minerals through Zois's domestic teacher Gabriel Gruber influenced the domestic headquarters of Baron Žiga Zois, the owner of the mining plants in the Jesenice and Bohinj. Nevertheless, Barba's amalgamation process, invented in 1609, drowned in oblivion, and the Freemason Ignaz von Born again resurfaced it in Slovakia, Prague and Vienna.¹⁶⁴⁵

14.5.4 *Erekiteru*

We offer the first descriptions of the introduction of vacuum pumps and electrostatic generators among the Japanese; devices were largely a product of the Dutch knowledge of vacuum researchers including Christiaan Huygens and Pieter Musschenbroek. In this way, they were hourly available among Japanese translators from Dutch language called Rangaku as part of Western science *Yogaku* (洋學).¹⁶⁴⁶ In view of the Japanese connection with the Dutch, we can expect that the Japanese easily learned about the vacuum experiments of the Dutchman Huygens (* 1629; † 1695), who began with his research of vacuum in The Hague in November 1661 after returning from a visit to Boyle. Huygens concluded his experiments with an unpleasant dangerous explosion during his lecture in Paris on April 14, 1668. Leyden's professor of philosophy and founder of the cabinet of physics in January 1675,¹⁶⁴⁷ Burchard de Volder (* 1643 Amsterdam; † 1709), continued to work as the executor of Huygens's last will. Franciscus Sylvius Le Boë's Leyden student Volder collaborated with Pieter's father Jonathan Musschenbroek (* 1660; † 1707), and Pieter's uncle Samuel Musschenbroek, who manufactured vacuum pumps in their workshop opposite the University. They used the designs of Boerhaave's professor of Aristotelian Philosophy Wolfers Senguerd (Wolfgang Senkward, Senguferolus, * 1646; † 1724) and Volder.

Volder gave them Boyle's plans acquired in London in 1675, so that soon enough, all experimentalists among Leyden teachers were provided with vacuum pumps, telescopes, microscopes and surgical devices.¹⁶⁴⁸ Senguerd provided private lectures with experiments at his home. In 1680 he described his own vacuum pump with one e piston in his *Philosophia Naturalis*;¹⁶⁴⁹ he used the achievements of Hooke, Papin and Boyle. 'sGravesande replaced the late Senguerd in 1724, and he also invited the students mainly to his home-based cabinet of physics, which was better equipped than an outdated physical laboratory at the university.¹⁶⁵⁰ After studying with Senguerd and Volder, 'sGravesande took up a botanical department at the Faculty of Medicine in 1709, and nine years later he was also offered a chemistry department at the Faculty of Philosophy. There he immediately put a vacuum pump into a chemical laboratory, designed experiments with it and began to cooperate with an Amsterdam-based scientific instrument maker Daniel Gabriel Fahrenheit. They competed with physicists who were in those times called "experimental philosophers."¹⁶⁵¹ Senguerd's and Boerhaave's student Pieter van Musschenbroek took the Chair of Physics at Leyden University in 1739, and a full-decade later, the first cousin of Hallerstein's mother Baron Erberg published the Latin translation of P. Musschenbroek's magnetic experiments in Ljubljana. Even though Sumitomo's library did not have Boerhaave's works, Boerhaave's uses of electrostatic and vacuum techniques for his chemistry and medicine were the first-class Dutch exports items for curious Japanese.¹⁶⁵² The Dutch doctors from Deshima soon learned all details of Pieter Musschenbroek's vacuum techniques and Leyden jars described by the Dutchman Musschenbroek in November 1745. Of course, Sumitomo bought P. Musschenbroek's books in Latin and French editions from 1748 and 1751.¹⁶⁵³ Hallerstein used the same books, although not always in the same editions; he read them in Ljubljana, and later in his Beijing Library. Sumitomo also enjoyed the highly popular Physics of Cartesian Jacques Rohault (* 1620; † 1675) in Samuel Clarke's edition issued in 1718. Of course, this edition completely lost the Cartesian spirit of

¹⁶⁴³ Barnadas, 1986, 44-45.

¹⁶⁴⁴ Barnadas, 1986, 78.

¹⁶⁴⁵ Barnadas, 1986, 79-80.

¹⁶⁴⁶ Jirō, 1992, 3.

¹⁶⁴⁷ Wiesenfeldt, 2008, 224-225.

¹⁶⁴⁸ Wiesenfeldt, 2008, 228, 232; Gerland, 1877, 670.

¹⁶⁴⁹ Cook, 2007, 285, 384; Schneider, 1986, 399.

¹⁶⁵⁰ Wiesenfeldt, 2008, 231.

¹⁶⁵¹ Wiesenfeldt, 2008, 231-232.

¹⁶⁵² Cook, 2007, 396.

¹⁶⁵³ Sumitomo, 1963, 11, 46; Yamazaki, 1952, 46.

the first edition of 1671, as Clarke added abundant Newton's remarks as footnotes below the lines, especially regarding to Boyle and Huygens' vacuum experiments. Those notes below the lines became much longer than the original Rohault's texts.¹⁶⁵⁴ Hallerstein's Pekingese Jesuits did not go so far and preferred the Geneva Latin translation of Th. Bonet from 1674 and the French Parisian reprint of 1683,¹⁶⁵⁵ which preserved the original Cartesian spirit. Rohault did not offer many illustrations of vacuum experiments, while he drew many optical and electrical examinations instead.¹⁶⁵⁶ Among the researches of mechanics published in the times of early vacuum experiments, Sumitomo's library much later acquired Monte, Borelli and Varignon's works. The books of Galileo's friend Guido Ubaldo del Monte also found its ways into the Auersperg and Valvasor's libraries of Carniola. Ubaldo described simple mechanical principles and gradually explained their use with nicely sketched machines.¹⁶⁵⁷ Borelli's posthumous edition came on daylight in Leyden and could therefore be part of the postponed rangaku export to the Japan Sumitomo Library with its nice paintings. The Japanese loved it despite the Latin language used, which many Japanese could not read; they were mainly observing the painting images, which was not uncommon in the land of the rising Sun. Galileo's student Borelli taught at one time Galileo's Chair of Mathematics in Pisa. Jointly with the Roman mathematician Michelangelo Ricci (1619; † 1682) he wrote about the forces involved in the collisions. That later cardinal Ricci was a recipient of the famous Torricelli's letter about a vacuum in his newly discovered barometer which began the whole story of the development of vacuum techniques that is still in progress. With Galileo and Torricelli's ideas Borelli clarified the hydraulic movement in caves, siphons and pipes.¹⁶⁵⁸ Borelli drew capillary phenomena and explained the vacuum phenomena in Torricelli's barometer;¹⁶⁵⁹ he explained Roberval's experiments with a barometer connected in a vacuumed vessel designed in 1648¹⁶⁶⁰ and Mersenne's weighting of air.¹⁶⁶¹ He used the presumption of the smallest

particles of air¹⁶⁶² but preferred to remain within the barometric vacuum experiments of Florence academics without using vacuum pumps. Similarly, in the conclusion of his book, Varignon described the puzzles of vacuum in an open tube filled with fluid unilaterally pressed with a finger of a brave experimenter¹⁶⁶³ as he was not yet aware of the harmfulness of the Idrija mercury.

Sumitomo acquired the first two of the three volumes of Viennese physics of the Piarist Dalham¹⁶⁶⁴ and Scarella's Bolognese discussion of magnets.¹⁶⁶⁵ Both books were less popular and perhaps nearly unknown in Beijing of Hallerstein's days. On the other hand, Sumitomo's library had an important Priestley's history of electricity in the German edition of 1769,¹⁶⁶⁶ Cavallo's experiments with electricity in a slightly later also German edition of 1782,¹⁶⁶⁷ Volta's Letters on Flammable Marsh Gases (1778),¹⁶⁶⁸ Nollet's electrical research in the French and Italian editions (1754, 1755).¹⁶⁶⁹ Florian Dalham de St. Theresa (* 1713 Vienna; † 1795 Salzburg) was a monk of the order of the Piarists, who at that time replaced the Jesuits at professorial positions in Central Europe including Habsburgian monarchy. Dalham courageously used the atomistic approach to prove the existence of a vacuum¹⁶⁷⁰ by giving the reader a sketch of Guericke's experiment with hemispheres¹⁶⁷¹ and the Torricellian barometer.¹⁶⁷² He also used Boyle's pump, but preferred the Dutch version of Musschenbroek and 'sGravesande double-barrelled design with two pistons;¹⁶⁷³ he used them for many experiments¹⁶⁷⁴ all the way to Papin's pot at high pressure.¹⁶⁷⁵ Finally, he afforded some data about the electricity¹⁶⁷⁶ and explained William Watson's (1715 London-1787 London) measurements of speed from 1748¹⁶⁷⁷ and Bose's discussion of

¹⁶⁵⁴ Rohault, 1718, 61-62.

¹⁶⁵⁵ Verhaeren, 1969, 767-768, 167.

¹⁶⁵⁶ Rohault, 1718, fig. 3 on table 14.

¹⁶⁵⁷ Monte, 1615, 223, 225.

¹⁶⁵⁸ Borelli, 1686, 226, 290-291, tab. 9 and 12.

¹⁶⁵⁹ Borelli, 1686, 131, figure 6-7 on tab. 6.

¹⁶⁶⁰ Borelli, 1686, 141-142.

¹⁶⁶¹ Borelli, 1686, 154-156.

¹⁶⁶² Borelli, 1686, 163.

¹⁶⁶³ Varignon, 1690, figure 27 on table 6.

¹⁶⁶⁴ Sumitomo, 1963, 5; Yamazaki, 1952, 43.

¹⁶⁶⁵ Not in Sumitomo, 1963; Yamazaki, 1952, 47.

¹⁶⁶⁶ Sumitomo, 1963, 77; not in Yamazaki, 1952.

¹⁶⁶⁷ Sumitomo, 1963, 4, 81; Yamazaki, 1952, 43.

¹⁶⁶⁸ Sumitomo, 1963, 4, 89; Yamazaki, 1952, 48.

¹⁶⁶⁹ Sumitomo, 1963, 11, 86; Yamazaki, 1952, 47.

¹⁶⁷⁰ Dalham, 1753, 2: 66-72, figures 6-9 on tab. 1.

¹⁶⁷¹ Dalham, 1753, 2: 139, 2: 351 figure 6. on tab. 3, 2: 361, figure 7 on tab. 19.

¹⁶⁷² Dalham, 1753, 2: 152, 171, figures 8-9 on tab. 4.

¹⁶⁷³ Dalham, 1753, 2: 347, figure 12 on tab. 18, 483.

¹⁶⁷⁴ Dalham, 1753, 2: 349-361, figure 1-7 of tab. 19.

¹⁶⁷⁵ Dalham, 1753, 2: 361, figure 9 on tab. 19.

¹⁶⁷⁶ Dalham, 1753, 2: 482.

¹⁶⁷⁷ Dalham, 1753, 2: 490.

electric light.¹⁶⁷⁸ In doing so, he used a friction electric spindle without a Leyden jar, which was required for the perfect *erikateru*. As it was usual for Piarists and other opponents of Jesuits, Dalham preferred Newton's model of gravity¹⁶⁷⁹ than the more difficult and complex Bošković's ideas. Luckily, Dalham still swore on the French version of the blades of the ship propelled by the power of a pair of horses¹⁶⁸⁰ instead of the later steam turbine experiments. He dedicated a special chapter to the puzzles of vacuum needed for the gunning of ballistic missiles.¹⁶⁸¹

The Netherlands-Japanese or Netherlands-Viennese-Ljubljana transmission of Dutch electrostatic and vacuum techniques were faster than the Chinese Jesuits whose resources were brought by the Jesuits from Paris and Lisbon to the Beijing French and Hallerstein Portuguese missions. The same applies to Erekiteru's electrostatic generators (エレキ, エレキテル), which were quickly beloved by the Japanese during the era of chamberlain (sobashū) Tanomi Okutsugu (田沼意次, * 1719; † 1788), who became senior counselor (Rōjū) in 1769.¹⁶⁸² With his interventions he marked the era between 1760 and 1786. The Erekiterus are very popular among the modern Japanese children and web is full of them. In 1765, the botanist Gotō Rishun (後藤梨春, * 1696; † 1771) described the *erekiteru* in his book *Orandabanashi* (紅毛談, Kōmōdan, The Tales of the Netherlands), and in 1768 and 1771 the Dutchmen introduced to shogun an enhanced Guericke's rotating electrostatic generator of John Dollond's son-in-law Jesse Ramsden (* 6/10/1735 Halifax; † 5/11/1800 Brighton). Ramsden developed the device after Hauksbee's replacement of the Guericke's sulfide ball¹⁶⁸³ with glass ball. He put it on sale in London in 1766, so the glass-disk version ribbed with four brushes quickly reached the networks of the Japanese Shogun in Edo, today's Tokyo.

Gennai's student was the expert on Rangaku Morishima Chūryō (Katsurgawa Hosai, courtesy name Shinra Bansō or Nisei Fūrai Sanjin in the meaning of the second Fūtai Sanjin, 森島中良, *

In 1776 **Hiraga Gennai** (平賀源内, nicknamed Fūrai Sanjin, 風来山人, * 1728/29; † 1779) successfully assembled an electrostatic device with the Leyden jar in a wooden box about two decades after Hallerstein and Benjamin Franklin got their electrostatic machines from London. Gennai's precious machine so profoundly marked the Japanese that even today the modern Japanese are cheerfully driving it under Gennai's name, looking forward to its sparking in the air or vacuum. In the 1760s, Gennai helped to exploit the Chichibu mine west of the city Chichibu in the Prefecture of Saitama (埼玉県, Saitamaken), and then assisted in the development of the coal mine Akita in the same prefecture in 1773/1774. He thus connected with the mining techniques of the family company Sumitomo, but he was particularly aware of the troublesome vacuum pumping of underground mining waters that were best handled by the European inventions of steam engines. Gennai contacted the Dutch and the Japanese interpreters of Dutchlanguage in 1764, by borrowing important books from Johnston's inventory of animals, Dodonaeus' herbarium, or George Eberhard Rumphius' (* 1627; † 1702 Ambon) book on fossils from Indonesia D'Amboinsche Rariteitkamer published in Amsterdam by F. Halmi in 1705. The inventor Gennai, in many respects, embodies the modern sparkling Japanese spirit, while the fine television shows were recorded about his actions.

1754; † 1810?). In 1787 in his Dutch diversities (Kōmō zatsuwa, 紅毛雑話), Morishima Chūryō offered a detailed explanation of the composition and functioning of the electrostatic machine, although Morishima Chūryō was primarily a writer of popular fiction. In 1798 in Naniwa (Osaka), Akisato Ritō (秋里籬島, worked 1780-1814) and Takehara Shunchōsai (竹原春朝齊, † 1800) in his fantastic narrative *Settsū meisho zue* (折津名所圖繪, Famous places in the Settsu province) published by Kawachiya Tasuke (浪花, 河内屋大助), described Hikida's store in the Fushima section of Osaka, where the trader exhibited an *erekiteru* designed by the artist Ōe among his Chinese and Korean offerings. They painted another guest who wrote his notes with the

¹⁶⁷⁸ Dalham, 1753, 2: 488.

¹⁶⁷⁹ Dalham, 1753, 2: 116-167, fig .10-11 on tab. 2.

¹⁶⁸⁰ Dalham, 1753, 2: 225, figure 2 on tab. 13.

¹⁶⁸¹ Dalham, 1753, 2: 247, figures 3-5 on tab. 15.

¹⁶⁸² Jirō, 1992, 51.

¹⁶⁸³ Gerland, 1883, 252.



Figure 14-8: , as conceived in Dalham's *Physic* that was read by the Japanese at the Sumitomo's Library (Dalham, 1753, Figure 7 in Table 1).

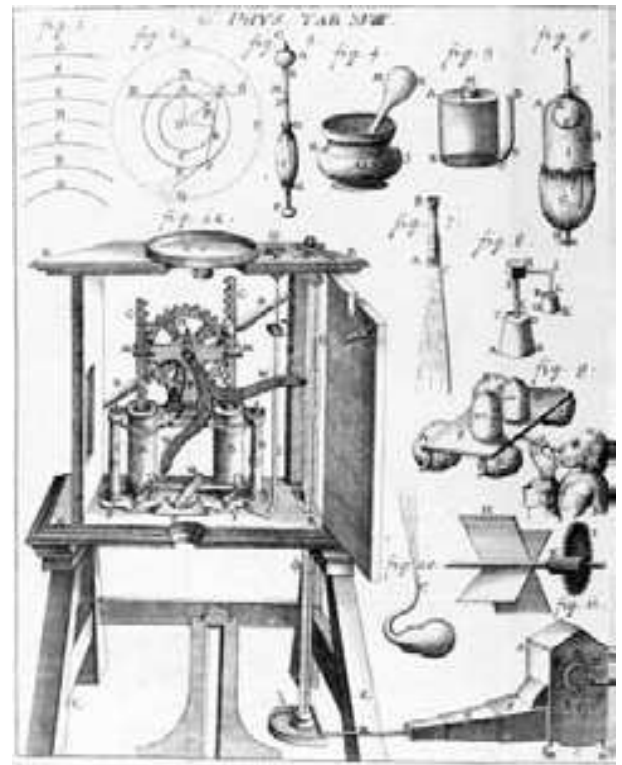

Figure 14-10: 'sGravesande's double-barrelled pump with two pistons in Japan (Dalham, 1753, Figure 12 on plate 18).

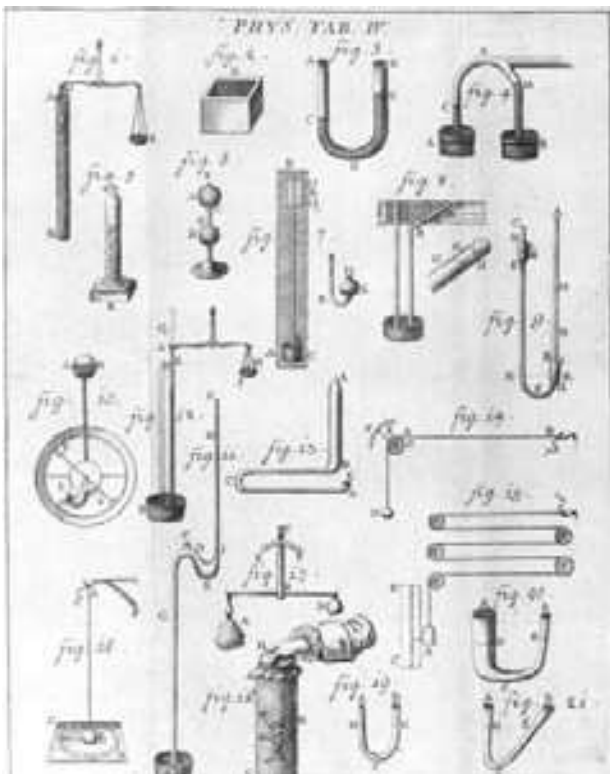

Figure 14-9: Barometers among the Japanese and Ljubljana natives (Dalham, 1753, Figures 7-12 on the table 5).

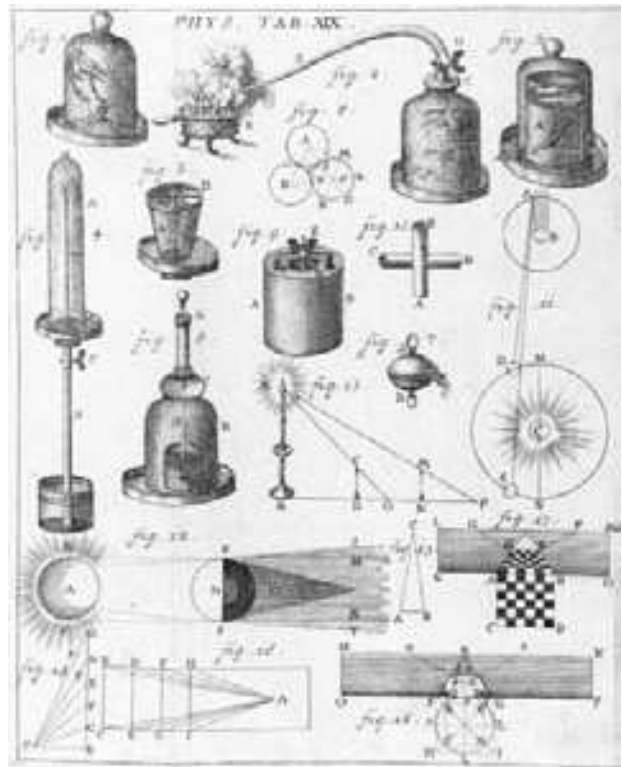

Figure 14-11: Poor rabbit, or maybe mice-like beetle in a vacuumed vessel (Figure 1) and a Magdeburg hemisphere (Figure 7) from Dalham's book at the Sumitomo's Library (Dalham, 1753, Table 19).

Western script.¹⁶⁸⁴ At that time, the private trade of skippers and crews of Dutch ships visiting Nagasaki brought numerous books to Japan. Those prints described geography, medicine, pharmacy,¹⁶⁸⁵ as well as vacuum techniques. Yoshio Kōzaemon studied Dutch books and asked Dutch doctors about their procedures, so through his translations he became a recognized expert in astronomy, geography and botany. He was appointed interpreter in 1742, and then got that nice duty a dozen times more.¹⁶⁸⁶

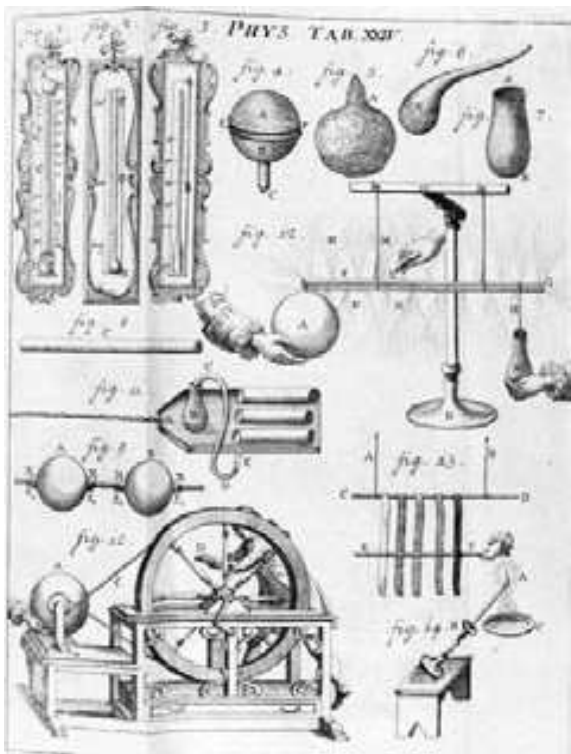

Figure 14-12: Erekiteru in Dalham Physics from the Sumitomo's Library (Dalham, 1753, pics 10-12 on table 24).

In 1788 Hashimoto Sōkichi (橋本宗吉, * 1763 Osaka; † 1836) began studying with Ōtsuki Genryō. He founded his private academy Shikandō in 1801.¹⁶⁸⁷ There Hashimoto later taught, cured and published the famous book Static electricity generated in the Netherlands (1811) under the protection of Hazama Shigomi (間重, * 1756; † 1816) from the Astronomical Office and the Tenmongata Observatory (天文方). Hazama Shigetomi was an important financier and former student of astronomer-physician Asada Gōryū (麻

田剛立, 1734-1799) in Osaka merchant academy *Kaitokudō* (懷徳堂). Their studies of physics called the investigation of basic things (*kyūrigaku*, 窮理学) followed the example of Neo-Confucian China. They added their first steps in chemistry called *seimigaku* (舎密学) by the misspelled term from the Dutch word for chemistry “*Scheikunde*”.¹⁶⁸⁸ In 1811, Hashimoto Muneyoshi published the first Japanese electrical manual under the title Foundations of Erekiteru as the Dutch know it (Orhan Shisei Erekiteru Kyūri-Gen). Hoashi Banri (帆足萬里, * 1778; † 1852) wrote about the Laws of Nature (窮理通, Kyūri-Tsū) in 1810, using as many as thirteen Dutch books. The Japanese researchers of electrostatics and vacuum techniques have called their electrostatic generator an “*erekiteru*” (today also *denki*, *fuka*) as part of physics (today: *butsuri*, *butsurigaku*), or physical sciences (today called “*rigaku*”), or natural sciences with physiology called “*kyūrigaku*”, or chemistry called “*semigaku*” (today: *chemisutori*, *chemisutori*, *kagaku*). The Japanese borrowed European (Dutch) names for barometer and chemistry, but not for watches or physics.

Hashimoto Sokichi supported the ideas of Benjamin Franklin and developed the *erekiteru* in the busy city of Osaka in 1811,¹⁶⁸⁹ where, under the influence of Sumitomo, every sixth of the 300,000 inhabitants dealt with copper reselling in 1685.¹⁶⁹⁰ Nearly two-thirds of the annual production of 6,000 tons of Sumitomo's copper was exported to China in 1697 for the manufacturing of coins.¹⁶⁹¹ Of course, the entrepreneur Sumitomo did not avoid even the direct exchange of goods, and he also acquired a lot of Chinese books or the books of Chinese Jesuits, although such reading was officially not allowed before 1720. Of course, the prohibition of ordinary folks does not apply to the wealthy.

In any case, Osaka became the center of modern Japanese electric and vacuum experiments, so Sokichi built his electric device in 1813 under the name of Static Electricity (*Erekiteru yakusetsu*). In doing so, he mainly relied on Dutch sources in connection with Musschenbroek's Leyden jar

¹⁶⁸⁴ Jirō, 1992, 52, 56, 60, 88-89, 177.

¹⁶⁸⁵ Jirō, 1992, 57.

¹⁶⁸⁶ Jirō, 1992, 61.

¹⁶⁸⁷ Bowers, 1970, 94.

¹⁶⁸⁸ Jirō, 1992, 91, 100-101.

¹⁶⁸⁹ Hashimoto, 1940.

¹⁶⁹⁰ Sumitomo, 1979, 13.

¹⁶⁹¹ Sumitomo, 1979, 14.

before the Japanese in the mid-19th century found out that the Dutchmen were, nevertheless, not the leading European scientists compared to the English, the French, or the Germans. The French revolutionaries temporarily occupied the Netherlands which convinced the Japanese that the Dutchmen might not be so powerful as they imagined. Tachu Horiguchi undertook static electricity a little later in 1814.¹⁶⁹² Sakuma Shōzan (佐久間象山, Zōzan, * 1811 Shinshu; † 1864) used Japanese domestic *erekiteru* for electric shocks with the induction flow of 1860,¹⁶⁹³ like Ingenhousz and Franklin imagined in their time.

The Japanese fell in love with vacuum pumps a bit after they endorsed *erekiteru*, although they had previously looked at their paintings in Winkler's or Martin's books, while Keill did not publish any proper pictures. Philipp Franz Balthazar von Siebold (* 1796 Wurzburg; † 1866 Munich) brought some vacuum pumps and a galvanic device in 1823, and the first Japanese vacuum pump was assembled at New Year's Eve in 1820. Siebold tried to smuggle the map of Japan and other secrets;¹⁶⁹⁴ the values of Dutch translations called *rangaku* were diminished when Siebold was arrested. He had to sail out of Nagasaki just before the new year of 1829 and returned only after the attack of Commodore Perry in 1853.¹⁶⁹⁵ Hasashige Tanaka (田中久重, * 1799 Kurume; † 1881) put together a flying machine and a pump for his air rifle and *munjitō* as "eternal light" in the forerunner of a company which his son-in-law later developed. That company got its name Toshiba officially designated only in 1978.¹⁶⁹⁶

The Japanese have published their own description of the vacuum pump barely in the book of Rinsō Aochi (青地林宗, * 1775; † 1833) called Atmospheric Observations (気海観 *ī*, Kikai Kanran), and soon after that in 1834, in nine volumes of Udagawa Shinsai (宇田川榛齋, * 1769; † 1832), who proved the use of air for breathing or burning and calculated the density of air. Udagawa Shinsai collaborated with Ogata Kōan (* 1810; † 1863) and Shinsai Udagawa's son-in-law Udagawa Yōan (宇田川榕菴, * 1798; †

1846), who succeeded him in assembling the first Japanese Voltaic battery in 1831. He published The initial principles of chemistry (舎密開宗, Seimi Kaisō) in 1840, based on William Henry's Elements of Experimental Chemistry (1799) with the Dutch adaptations of the Lavoisier system.¹⁶⁹⁷

Motoki Ryōi (本木庄太夫良意, 1624–1697) translated the Dutch edition of Johann Remmelin's (* 1583 Ulm; † 1632 Augsburg) *Pinax mocoocsmographicus* (1667, Amsterdam: Paul Mathias)¹⁶⁹⁸ and thus paved the way of his heir Motoki Ryōei (Yoshinaga, 本木良永, 1735–1794), who was already the third generation of the same family of interpreters Motoki. He translated the Dutch botanic in 1771 following the order of Hiraga Gennai. Then Motoki Ryōei translated astronomy (1773/74–1788), and in 1792 a further clarification of the barometer (Oranda kōshōgi fukai) which was strongly vacuum-based. The student of Tadao Shizuki¹⁶⁹⁹ named Baba Sajurō (Sadayoshi, 馬場佐十郎, * 1787; † 1822 Edo) was the leading Dutch language teacher and official of the Astronomical Department's *bansho wage goyō*. In 1810, the Motoki's book was expanded into a Translated Handbook for the Barometer (*Senkitō yakusetsu*), also called *Barometoru tenki keigi*. In 1817, Baba published *Taisei jiki zusetsu* as Illustrated explanations of the Western clock and *Garasu seihōshūsetsu* (Complete explanation of glass manufacturing processes).¹⁷⁰⁰

On the other shore of Yellow sea Hallerstein read the books of the Dutch vacuum researcher Huygens, mostly the *Horologium oscillatorum* in the first Paris edition of 1673; his neighbors at the French Jesuit station afforded a former copy of the Lyon Jesuit college.¹⁷⁰¹ Despite direct connections with Dutch vacuumists, Motoki Ryōei preferred to translate the book by Johann Adams senior (* 1709; † 1773 London), the maker of vacuum mathematical devices at the court of King George III (1738–1820). Of course, Motoki Ryōei used the Dutch version because he did not know English

¹⁶⁹⁷ Montgomery, 2000, 238–239.

¹⁶⁹⁸ Jirō, 1992, 19, 21–22, 23, 25.

¹⁶⁹⁹ Groot, 1998, 12.

¹⁷⁰⁰ Jirō, 1992, 62–63, 101, 103–104.

¹⁷⁰¹ Beijing's scientists have afforded a third copy without any proprietary entries, which we also miss in the Huygens' *De circuli magnitudine inventa* (1654. Leyden: Elzevier) (numbers 1845–1848 v noted by Verhaeren, 1969, 543).

¹⁶⁹² Horiguchi, 1978.

¹⁶⁹³ Azuma, 1993, 151; Fuse, 1989, 151; Nakamura, 2009, 156.

¹⁶⁹⁴ Nakayana, 2009, 157–158.

¹⁶⁹⁵ Jirō, 1992, 122–123, 126, 127.

¹⁶⁹⁶ Hashimoto, 2009, 33–34.

language. Although Motoki Ryōei did not add newly invented ideas, he also commented the works of Benjamin Martin (* 1704 Worplesdon; † 1782 London) and Johann Heinrich Winkler (Winckler, * 1703 Wingendorf near Lauban; † 1770 Leipzig). Winkler's *Electricity* (1744/45) influenced the Stična Cistercians. Winkler's *Anfangsgründe der Physik* (1754) was used by Motoki Ryōei in the Dutch translation (1768). It was also purchased by the cousin of Hallerstein's mother Erberg for higher studies in Ljubljana in 1755. Winkler was Christian Wolff's fan and he took over Wolff's Department of Philosophy at the University of Leipzig in 1739. Unfortunately, he did not afford any index in his physics textbook. After the introductory mathematical part, he described the Torricellian Barometer in the variations of Rohault, Wolff, Musschenbroek and the like,¹⁷⁰² but did not deal with Guericke's vacuum experiments, which Winkler preferred to describe in his book on *Electricity* six years later.¹⁷⁰³ Winkler described Musschenbroek's experiments with a mercury thermometer.¹⁷⁰⁴ Motoki Ryoei used Benjamin Martin's part *Philosophical Grammar* (1735) designed for the teens in the Dutch translation of the later famous historian Jan Wagenaar (* 1709; † 1773) addressed as the *Filosofische Onderwijzer* (1744 Amsterdam), which Hallerstein's uncle Erberg read in the Italian translation of 1769.

Žiga Zois had the other Benjamin Martin's works on a vacuum pump, on a steam engine and optics. After the introductory part,¹⁷⁰⁵ Martin mostly excelled in final fourth part of his work entitled *Of Hypotheses, of Experiments, of various Instruments for that purpose their Use*.¹⁷⁰⁶ There he described the vacuum pumps, but only in later editions he added Hauksbee's achievements with the image of Hauksbee's pneumatic device, namely the vacuum pump.¹⁷⁰⁷ In Japan, the edition of 1735 did not have the first three paintings from the reprint published in 1755.¹⁷⁰⁸ Martin explained the philosophical background of vacuum and electricity¹⁷⁰⁹ in the introduction, but did not

publish the image of *erekiteru* because he saved the treatment of static electricity for his other books. In all editions of his *Philosophical Grammar* book, Martin divided his dialogues between student A and teacher B in the in four parts, where *Aerology*¹⁷¹⁰ figured as a third part with the *Theory of the Atmosphere or the Air* in the first four chapters.¹⁷¹¹ Both Martin's speakers admired Boyle's vacuum pump¹⁷¹² in Roberval's Parisian performance under Pascal's influence.¹⁷¹³ Martin added Keill's calculations,¹⁷¹⁴ the latest 'Gravesande's and other experiments.¹⁷¹⁵ In the first edition, which was used by Motoki Ryoei, there were no images of a double-piston pump¹⁷¹⁶ or long footnotes below the line, which even exceeded the length of the original text in the fifth edition of 1755. The pages dedicated to the vacuum were those where Martin most notably added footnotes and additional sketches after the first edition, which clearly shows how rapidly vacuum technology developed during Hallerstein's youth.

Shizuki Tadao (志 筑 忠雄, Chūhirō Nakano, Ryūho, * 1760 Nagasaki; † 1806) due to physical weakness soon retired as a rangaku interpreter in Nagasaki.¹⁷¹⁷ He relied on Chinese sources in his Copernican theory from 1759 and 1766, and between 1782-1802 he translated a somewhat outdated book of John Keill (* 1671 Edinburgh; † 1721 Oxford). In 1798, he first published the second part of Keill's *Introductiones ad veram Astronomiam* as the *New Text of Transient (Calendar) phenomena* (Rekishō Shinsho, 曆象新書) and communicated the following two parts on physics and circular motion in 1800 and 1802,¹⁷¹⁸ although the physical part was the first in the original Keil's design.

Perhaps the poor translator Shizuki Tadao had a bit more trouble with that part. The first two volumes were first written in classical Chinese language, but in the end, all three volumes were published in Japanese language.¹⁷¹⁹ During his studies at

¹⁷⁰² Winkler, Bakish, 1738, 248-254, fig. 5-7 on table 14.

¹⁷⁰³ Winkler, Bakish, 1744, 5, 7.

¹⁷⁰⁴ Winkler, Bakish, 1738, 257.

¹⁷⁰⁵ Martin, 1735, 22-28; Martin, 1755, 19-28.

¹⁷⁰⁶ Martin, 1735, 27; Martin, 1755, 26.

¹⁷⁰⁷ Martin, 1755, 27, table 2.

¹⁷⁰⁸ Martin, 1735, 41 table 1 is identical to table 4 in Martin, 1755, 39.

¹⁷⁰⁹ Martin, 1755, 105-106.

¹⁷¹⁰ Martin, 1735, 143-185; Martin, 1755, 176-218.

¹⁷¹¹ Martin, 1735, 143-155; Martin, 1755, 176-187.

¹⁷¹² Martin, 1735, 147; Martin, 1755, 177.

¹⁷¹³ Martin, 1755, 179.

¹⁷¹⁴ Martin, 1735, 150; Martin, 1755, 184.

¹⁷¹⁵ Martin, 1755, 184.

¹⁷¹⁶ Martin, 1755, figure 18 in table 14.

¹⁷¹⁷ Groot, 1998, 10, 118.

¹⁷¹⁸ Ohmori, 1963, 147.

¹⁷¹⁹ Montgomery, 2000, 229-230.

Motoki Ryoei's class, Shizuki Tadao quickly found out that he could choose the more modern records of Benjamin Martin or Winkler instead of Keill's data¹⁷²⁰ for his translation. Keill illustrated hydraulic vessels,¹⁷²¹ experiments with ships,¹⁷²² slopes of cannon shots;¹⁷²³ but he did not afford to present any vacuum pumps or electrostatic experiments. He finished the physical part of his work with the centrifugal power of the virtuous Huygens,¹⁷²⁴ whom the translator Shizuki Tadao probably also knew from other Dutch sources. In the Milan edition of 1742, Keill's work was extremely popular among the Ljubljana and Novo Mesto Franciscans; Žiga Zois used the Parisian edition of 1746. Hallerstein himself, however, preferred the 'sGravesande's Leyden Edition published in 1725.¹⁷²⁵

14.5.5 Conclusion

Hallerstein's role in Beijing's electrical and vacuum experiments is not as clear as his publications in astronomy, cartography or Chinese demographics. Many of these studies were designed as joint works under the auspices of the imperial court of Qing dynasty.¹⁷²⁶ Since the Carniolan Hallerstein was a leading Jesuit scientist in Beijing, none of the electrical or vacuum investigations could have been carried out without his participations. Here we first presented the Beijing-based Jesuit Electrophorus as the fundament of the later Voltaic inventions, which are the foundation of modern vacuum science and electrical engineering. Carniolan Jesuit Hallerstein was undoubtedly a blessing for Chinese science and technology, but the Chinese lost their Jesuits shortly before the Opium Wars so that Hallerstein's knowledge could not help them in defense anymore. The beginnings of Hallerstein's vacuum and electrotechnical research were indeed bright and enabled later developments of dynamos and electric bulbs¹⁷²⁷ after the Jesuit technical heritage was destroyed at the Imperial Summer Palace.¹⁷²⁸

The Chinese people liked to imagine cyclical historical developments, while the Japanese have always preferred a linear arrow of time. The Chinese and Japanese approaches to our western science were and still are basically different. While the Chinese would like to see that all the European knowledge has evolved from ancient Chinese inventions, the Japanese prefer the opposite extreme and try to sell themselves as mere emulators of Western or Chinese achievements. In fact, the Japanese have received so many Nobel Prizes in the last decade, but the Japanese tried to diminish their merits as some Japanese winners are exploring in the United States anyway. The reality, of course, is different. The overlapping Jesuit-Chinese merit of Hallerstein's days made possible Volta's discovery of the battery as the basis of electrodynamics, while the Japanese-Dutch rangaku association was also instrumental after the Dutch Musschenbroek's discovery of the Leyden jar and the improvements in the vacuum technique that enabled the Japanese erekiteru as a design unusual for European researchers. The electrophorus of Hallerstein's Jesuits may have been the latest Jesuitical achievement in Beijing. It has been upgraded by Europeans over time and returned to China in the form of a completed electrical engineering. In today's globalized world, something similar cannot be easily repeated. London's exports of Leyden jars to Franklin's Philadelphia also returned to Europe as boomerangs with lightning rods and other Franklin achievements, although we still do not know what kind of improvements of electrostatic and vacuum devices may have been designed in the then Ljubljana or in Edo (Tokyo) except for erekiteru. In any case, the needy Needham believed that the Japanese and the Chinese would develop similar Westernized science even without European intervention, but we, together with Nakayama, endorsed the opposite view.¹⁷²⁹ There are many different possibilities of economies, cultures, languages and all other human endeavors, therefore the humans could also develop different kinds of sciences if they have a chance to avoid the globalization and uniform approach towards the seemingly unique truths.

The readings define the modern man. The attractive weighty wisdom determined the approaches of Hallerstein more than anyone else, as accomplished more than all other scientists of

¹⁷²⁰ Nakayama, 2009, 74, 347; Jirō, 1992, 97.

¹⁷²¹ Keill, 1739, 113 (figure 8 on table III).

¹⁷²² Keill, 1739, 118 (figure 4-6 on table IV).

¹⁷²³ Keill, 1739, 186 (figure 4 on table V).

¹⁷²⁴ Keill, 1739, 186 (figure 4 on table V).

¹⁷²⁵ Verhaeren, 1969, 556-557.

¹⁷²⁶ Hostetler, 2007, 126-127.

¹⁷²⁷ Dilaura, Lambert, 2001, cxcvi.

¹⁷²⁸ Rinaldi, 2006, 210.

¹⁷²⁹ Nakayama, 2009, 190.

his generations. He achieved no less than the position of the leading scholar of the heavenly empire. Hallerstein's role in Beijing's electricity exploration is by no means as clear as his leading role in the Chinese astronomy, cartography or demographics. His many research projects were often a social project under the auspices of the Chinese imperial Qing Dynasty.¹⁷³⁰ In this study, for the first time in depth, we presented his share of the invention of the electrophorus, which was the foundation of Volta's later successes. Above all, we presented the bookshelf from which Hallerstein pumped up his enviable knowledge.

In any case, Hallerstein was Slovenian language speaker and worth of the all money available. A Chinese national disaster in the 19th century might have rotated differently if anyone could continue Hallerstein's transfer of knowledge from Europe to the Chinese court (and back). But there was no such hero around, and the shame of defeat in the Opium Wars (1839-1841) was the reflection of the deep technical backlog of the Chinese in decades after Hallerstein's death. On the other hand, the creative transmitters of knowhow of Hallerstein's sort made the world a global unit and prevented any possible successful development of other non-European types of sciences and technology at the Far East.¹⁷³¹ The world became one, but we could hardly judge if it became the best of all possible worlds in Leibniz's sense.

¹⁷³⁰ Hostetler, 2007 *Global or Local*, pp. 117-135.

¹⁷³¹ Nakayama, 2009 *Collected Papers*.

15 Pumping Vacuum for Full Enlightenment

15.1 Vacuum Pumps as Standard Experimental Tools for Enlightenment

It is hard to decide if we the Westerners borrowed more for the Far Easterners or vice versa, especially after the modern global success of the Chinese knowhow in the Anthropocene. In any case, the period of European enlightenment with Hallerstein at the top Beijing scientific positions was decisive for the technological modernizations of the world we still live in.

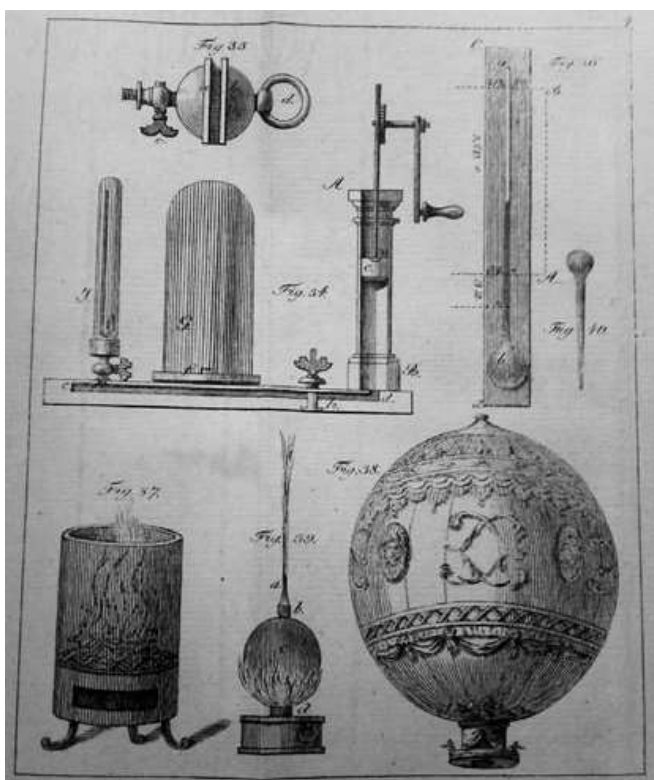

Figure 15-1: Vacuum pumps in the Ebert's book for youth held by the Ljubljana Franciscans' library (Ebert, 1804, table 5, with the permission of Prof. Dr. Miran Špelič, OFM).

The enlightenment technological modernizations were based on British steam engines which reversed the techniques of vacuum pumps to achieve higher instead of lower pressures. Hallerstein and his collaborators presented the heavy vacuum pumps to the Chinese emperor, but they failed to do the same with even heavier

Savary and Thomas Newcomen's pre-Watt steam engines also because those machines were rare in Hallerstein's native Europe. The failure of Hallerstein's Jesuitical transfer of steamboats knowhow to Beijing might be decisive for later Chinese humiliated defeats in Opium wars, because the Chinese effectively missed few decades of westernized modernizations of the techniques including vacuum pumps and steam engines accelerated during the Napoleonic wars.

15.2 Enlightenment Vacuum Pumps among Slovenes

The export of vacuum devices to the Far East was just one aspect of globalization of sciences expanded across the oceans. The similar spread simultaneously carried exported western novelties into the Russian or Habsburgian milieu of Peter the Great and the emperor Leopold I. Both passed their thrones to the able females like Katherine the Great and Maria Theresia, who finally succeeded in



Figure 15-2: Text and pictures in the Ebert's book for youth held by the Ljubljana Franciscans' library (Ebert, 1804, 61 and the table of paintings, with the permission of Prof. Dr. Miran Špelič, OFM).

modernization and westernization of their local sciences based on vacuum tools. Both empires and even the Chinese realm the Jesuits as their transmitters, but at least in Habsburgian monarchy the other monks were also instrumental in spreading the novelties, including Franciscans and Cistercians. As secularization and needs for state employed engineers grew, there were also many technical experts outside the monastic orders, especially in the Carniolan Idrija mercury mine. The first cousin of Hallerstein's mother and once removed uncle of Jožef Kalasanc Erberg, a Jesuit

professor of mathematics and physics Bernard Ferdinand Erberg, brought to Ljubljana the first documented vacuum devices whose inventory is available to us. In a modern way he equipped the new Ljubljana higher education physics cabinet and filled it with his 54 new experimental devices in 1755, with which he emphasized the research of vacuum. The winning horses of the Jesuit vacuumists of that time were of course Lana's balloons.

Johann Jakob Ebert (* 1737; † 1805) published many natural historical textbooks,¹⁷³² read by Carniolan barons Erberg and their neighboring Franciscans. In 1768 Ebert became the domestic teacher of the children of Russian minister Teplov in Petersburg. From 1747, Grigory Nikolaevich Teplov (Григорий Николаевич Теплов, * 1717; † 1779) led the Petersburg Academy on behalf of its president, Kirill Grigorievich count Razumovsky (Разумовский, 1728-1803). The widowed Teplov married Razumovsky's first cousin and brought Katarina to the Russian throne in 1761/1762. He argued with Lomonosov and provided the Russian translation of Christian Wolff's works, which paved the way for later Gruber's influence on Petersburg academics. In 1769, Ebert became a professor of basic mathematics in Wittenberg, and he took over the mathematical chair there in 1784. This was already the time when the thinking of the vacuum was greatly influenced by Bošković's physics.

15.3 Bošković's Vacuum

15.3.1 Introduction

The movement in the vacuum was the toughest nut of Aristotle's physics, which prevailed in Europe and in the Arabic countries for almost exactly two millennia. Despite the convincing experiments of Torricelli, Guericke, Boyle and Pascal, even the thinkers of the highest level as Descartes or Leibniz were unable to save themselves from the tangled rows of movements in an empty space. Bošković was the first to succeed in the long-awaited explanation of the vacuum as a mixture of Jesuitical Aristotelian traditions, Newton's physics and Leibniz's nature which does not allow jumps.

¹⁷³² Wilde-1486, NUK-8405, Lind, 1992, 373 .

Bošković designed the vacuum as a home for a multitude of indivisible point centers of forces without dimensions, ancestors of modern atoms or even elementary particles. After his three or more visits to Ljubljana, Bošković's physics became the foundation of Ljubljana's lectures of physics, as well as the core of teaching in the whole of Europe for at least three generations, involving Bošković's Viennese friend Karl Scherffer, Scherffer's student Gabriel Gruber, Gruber's student Jurij Vega, Vega's student – and so on down to J. Stefan's student Boltzmann, who explicitly praised Bošković.

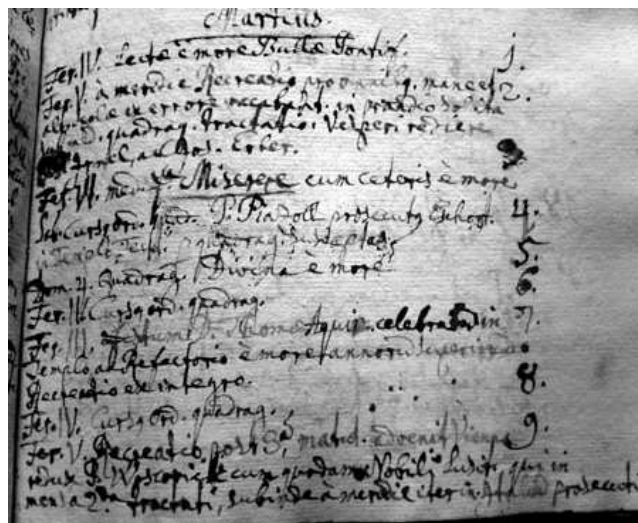

Figure 15-3: Bernard Ferdinand Erberg's note in the Jesuitical diary of Bošković's overnight stay at the Jesuit of Ljubljana on March 9, 1758 (Erberg, 1758, 1742r)



Figure 15-4 Memorial plaque on Bošković's house in Dubrovnik (photographed by the author in 2012)

The theoretical solution to Aristotle's controversy has inflicted so many thinkers subjected to religious dogmas that they have not seen another

way out, except for the repugnant assumptions about an impossible vacuum, which, however, can be created by the Almighty God. Bošković saved them from this kind of problems, but at the same time the scope of his merits was also great at the experimental level. We will describe two of them related to the vacuum techniques of those days: measurement of the speed of light in an empty space or in the water to resolve the dispute between the defenders of the particle and wave nature of light, and the exploration of the vacuum in the solar system as the basis for a flight with a vacuum balloon.

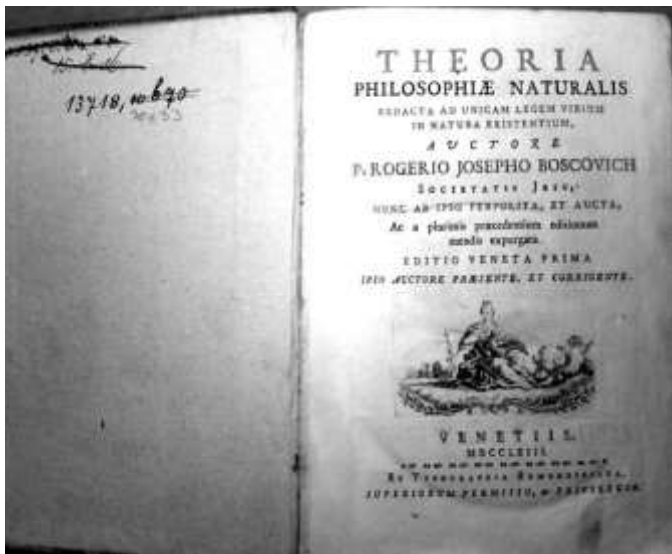

Figure 15-5: Venetian edition of the main Bošković's work (1763) at Ljubljana Franciscans' library (courtesy of Prof. Dr. Miran Špelič, OFM).

15.3.2 Bošković's Water-Filled Telescope

Newton was convinced that light consists of particles. Huygens and Euler preferred waves, while Descartes preferred a pressure between the light and the observer. Bošković admired Newton, although he occasionally doubted the scope of his gravitational law. To decipher the basic dispute of the then optics, as a teacher of mathematics in the Pavia and then at the Milan courthouse (palatine) school, Bošković suggested measuring with telescopes in 1768. In one occasion, he intended to fill the hose if a telescope with water, while Bošković's other suggestion was to observe the star through a vacuum or air. He described his ideas to his friend Lalande (1773),¹⁷³³ a Parisian freemasonic astronomer. Of course, Lalande

immediately published Bošković's advice in a textbook printed in 1781.

Bošković assumed that he would observe the change in the angle of the aberration of a star by measurements through the telescope with an empty tube and with a tube full of water. James Bradley (* 1693; † 1762) first observed aberration in London as a small ellipse, described by the image of a vertically observed star during the Earth's elliptical journey around the Sun in 1725 and 1728. The ellipse is reflection of the Earth's own paths. The imaginary Bošković concluded that such an ellipse should increase when viewed through a telescope tube filled with water. The curious Jesuit knew that the speed of light waves decreased in water and thus increased aberrations. On the contrary to aberrations, the speed of particles of light would grow in water. Thus, he wanted to kill two birds with one stone: to confirm Copernicus's circulation of the Earth, and to decide on the controversy between the particles and the waves of light.

For the sake of disputes in Brera in Milan, Bošković could not arrange his experiment among the Italian virtuosi. He described it again in his collected works in 1785,¹⁷³⁴ just before his death. In 1788 and 1790, the British promoter of Bošković's ideas, the Scotman John Robison (* 1733, Boggall at Glasgow; † 30. 1. 1805, Edinburgh), found that Bošković's comparison between water and vacuum telescope would provide evidence of the absolute motion of the Earth; he expected failure, therefore nothing promising with the presumed same result for both telescopes. In 1782, the similar thoughts appeared to Robison's friend, a Glasgow practical astronomy assistant Patrick Wilson (* 1743; † 1811).¹⁷³⁵ Soon, their skepticism influenced Fresnel across the Channel in 1818. Bošković's device was barely tested by the director of Cambridge Observatory Georg Biddell Airy (* 1801; † 1892) on the star BY Draconis in March and in autumn of 1871.¹⁷³⁶ On his own merits, it was lucky that Bošković himself did not measure something like that because Robinson—prophesied perfectly correctly. The Airy did not measure any difference in the measurements through an empty and water-filled telescope, which would surely cause the impatient

¹⁷³⁴ Tomić, 2005, 268.

¹⁷³⁵ Wilson, 1782, 58.

¹⁷³⁶ Airy, 1871–1872, 37.

¹⁷³³ Tomić, 2005, 263.

Bošković to rage. Airy was already a special freak, because he ignored the newly discovered Neptune, and he disliked Faraday's ideas; the queen herself quit four times the propositions to bring angry Airy to the knighthood until she finally recognized his undeniable scientific merit in July 1872. Airy's many surprising measurements became one of the foundations of the physical world's reforms in Einstein's theory of relativity,¹⁷³⁷ which Airy no longer experienced as he died soon enough; he certainly would have disliked Einstein's ideas after he could not digest even Faraday's field theory.

15.3.3 *Dubrovnik Natives on Lana Terzi's Vacuum Balloons*

Bošković's vacuum telescope, of course, was not his only contribution to researching the vacuum. Bošković's Roman student and noble Dubrovnik cousin Brno Džamanjić (Bernardi Zamagna, Zamanja, * 1735, Dubrovnik; † 1820, Dubrovnik) initially became the Jesuit following Bošković's example but preferred to join the Dominicans after a ban on the Jesuit order. Like Benedikt Stay, Bošković and their cousin Rajmund Kunić (Cunich), their pupil Džamanjić liked to use his pen for Latin hexameters devoted to science. He heard a lot from Bošković about their religious co-brother Lana Terzi of Brescia, who had planned a flight with a vacuum balloon a century ago, without having enough money for such a feat. Džamanjić even more attuned to his heart Bošković's vision of the vacuum in space and

the empty spaces which separate point centers of forces. Thus, Džamanjić published a Latin song about Lana's ship only a decade before the success of paper makers named Brothers Montgolfier.¹⁷³⁸ They were members of Lalande's Parisian Masonic Lodge of the Nine Sisters. The famous brother (not sisters) indeed ascended a similar but not completely empty device. Montgolfier's success, supported by the Freemasonry exclamations of Benjamin Franklin, if not the king himself and other Parisian observers, has greatly increased the popularity of Džamanjić' poems about two passengers on a flight around the globe, often reprinted by enthusiastic publishers of later

¹⁷³⁷ Tomić, 2005, 270.

¹⁷³⁸ Joseph Michal Montgolfier (* 26. 8. 1740, Videlon-les-Annonay; † 26. 6. 1810, Belaruc-les-Bains) and Jacques Étienne Montgolfier (7. 1. 1745, Videlon-les-Annonay; † 2. 8. 1799, Serrières).

generations. Dedalus's legend became flesh, even if until this day still without the vacuum of Lana Terzi.

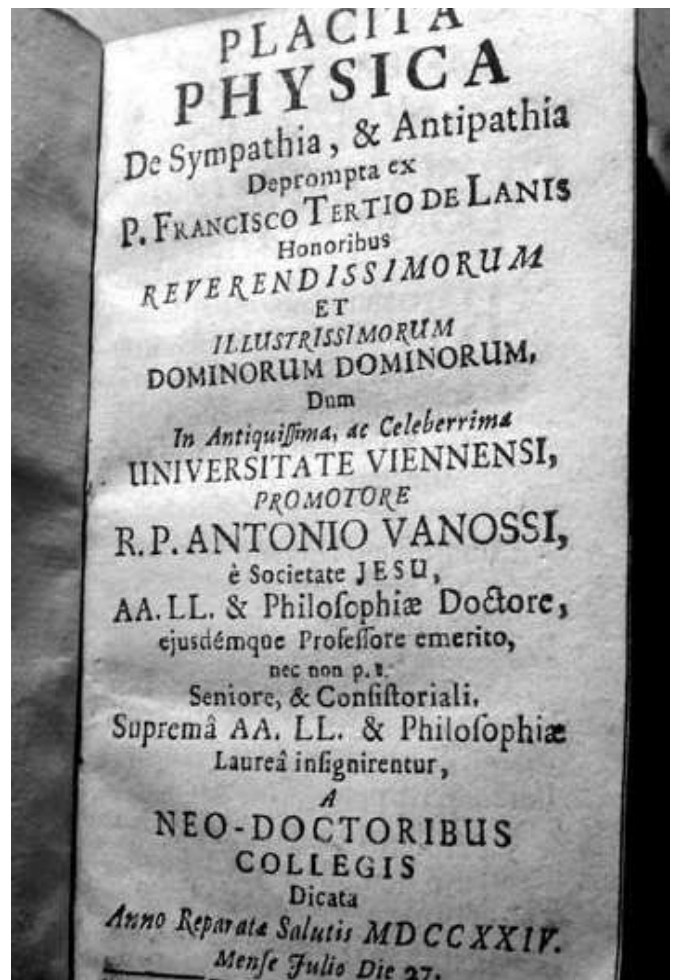

Figure 15-6: The title page of Lana's Physics, showing the edition of 1724 in Ljubljana Franciscans' library (with the courtesy of Prof. Dr. Miran Špelič, OFM)

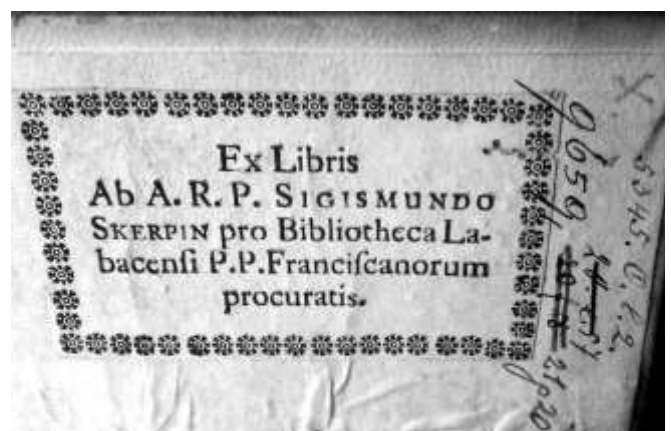

Figure 15-7: Škerpin's bookplate at Lana's Physics edited in 1724 and kept at Ljubljana Franciscans' library (with the courtesy of Prof. Dr. Miran Špelič, OFM)

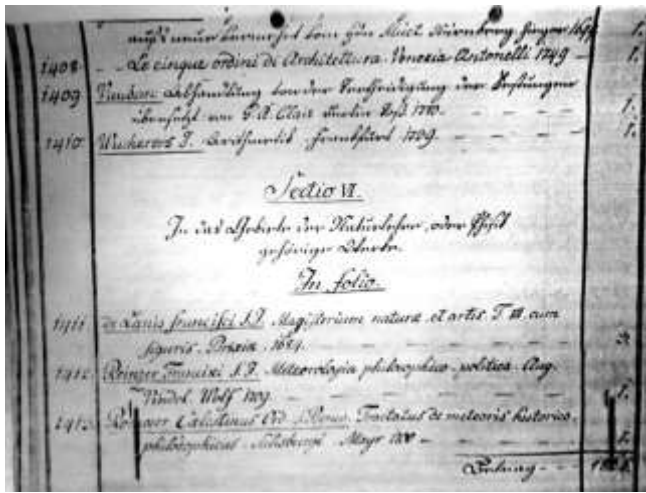

Figure 15-8: Lana's Magisterium (1684) in the catalogue of the Lyceum Librarian Wilde in 1800 (Wilde, 1803, page 117, reference code 1411).

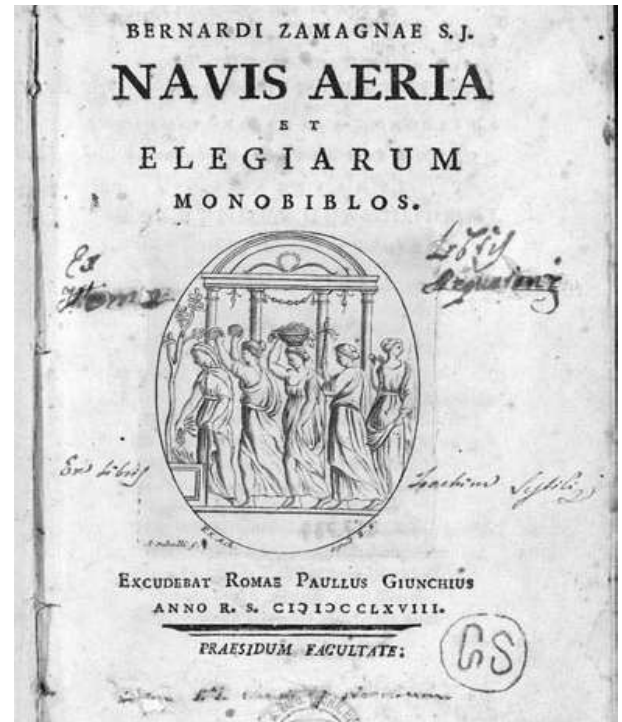

Figure 15-10: The cover page of a poem about the vacuum flight of Bošković's student Džamanjić (Zamagna) from 1768



Figure 15-9: Physics of the Lana in the list of Ljubljana Librarian Wilde in 1800 (Wilde, 1803, page 125, No. 1529)

Džamanjić conceived the flight of two courageous travelers, who surveyed the world on the Lana's vacuum ship. He first drew their adventures and then described them in two books, to which he finally added elegies on other topics. He mentioned Francesco Zanotti (* 1692; † 1777)¹⁷³⁹ as the secretary of the Bologna Institute, and brother of astronomer Eustachio Zanotti. With the maker of the vacuum balloon Lana Terzi, Džamanjić linked the verses to Johann Christoph Sturm of the Altdorf University, who supplemented the ideas of Lana Terzi in 1675.¹⁷⁴⁰ Džamanjić summarized the achievements of professor of mathematics in Pisa and Rome Borelli. Giovanni Alfonso Borelli (* 1608 Naples; † 1679 the school of Piarists in

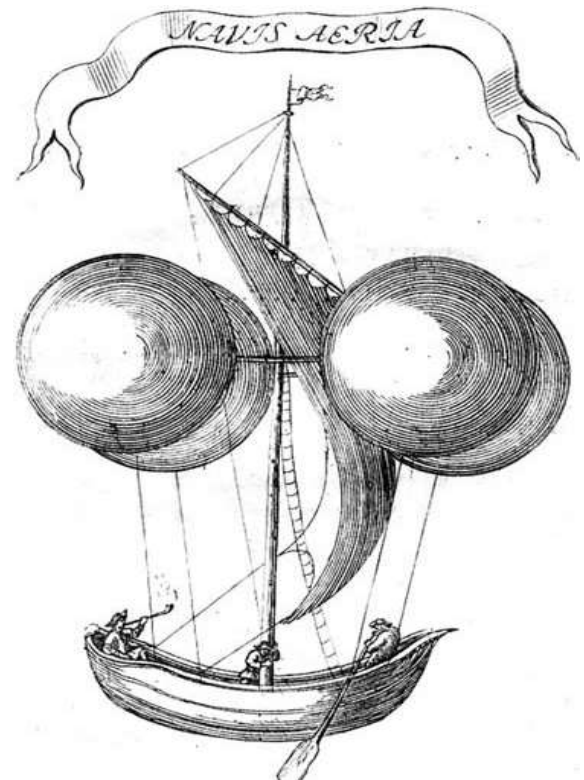

Figure 15-11: Two patriotic young men with a helper assistant enjoy the journey around the world under four vacuum balloons in the poem about the vacuum flight of Bošković's student Džamanjić (Zamagna) from 1768.

¹⁷³⁹ Džamanjić, 1768, 1: V.

¹⁷⁴⁰ Džamanjić, 1768, 1: XII.

Rome) used to be the disciple of Galileo's student Benedetto Castelli. Borelli was known as one of the leading researchers of flights. Borelli refused to imitate the birds because of the evidently weaker human muscles, and he also challenged the stability of the Lana's vessel under vacuum spheres. History has proved him right in both cases.

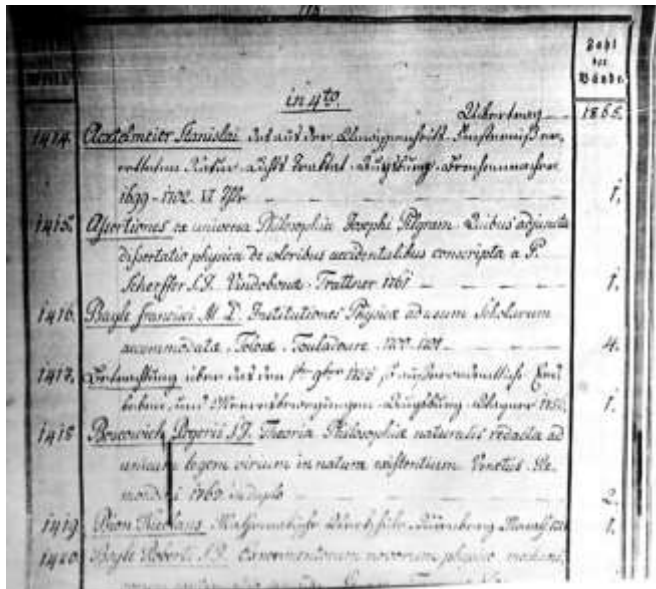

Figure 15-12: Bošković's book in the list of Ljubljana lyceum librarian Wilde in 1800 (Wilde, 1803, page 118).



Figure 15-13: Vacuum devices of the Carniolan agricultural society in the Ambschell's census of 1785 (Ambschell, 1785)

Džamanjić was interested in the opinions of Newton¹⁷⁴¹ and Bošković about the composition of the Lunar atmosphere,¹⁷⁴² as well as Bošković's model of the northern lights (Aurora borealis).¹⁷⁴³ He described Bošković's planned tour for the

observations of Venus's passage over solar disc in California in 1769 with Kunić's song of praise; unfortunately, Bošković's trip has failed, since the Spanish owners of California forbade any visits of Jesuitical Bošković's religious co-brothers. Džamanjić continued the report on Bošković's disease in Istanbul,¹⁷⁴⁴ where Bošković again tried without a luck to experience the passage of Venus: as a monk he might have a lot of problem with goddess Venus anyway. Of course, Džamanjić refused an outdated fear of an empty, called horror vacui.¹⁷⁴⁵ He was assisted by the opinions of French monk Mersenne and Duns Scotus.¹⁷⁴⁶ As a real air-vacuum seaman, Džamanjić's passengers used Harrison's watch to accurately determine the position of their vacuumed vessel;¹⁷⁴⁷ they did not forget to take compass and maps with them, and they were particularly interested in the vertical distribution of clouds. It was a real problem there, as nobody knew for sure how the clouds interact with each other. Džamanjić has linked the story of his ballooning heroes under four vacuum balloons with fashion pioneering vaccination against smallpox after the poor bride of Emperor Joseph II passed away at the court of his mother Maria Theresa.¹⁷⁴⁸ Basically, Džamanjić referred to the English manufacturer of vacuum devices Benjamin Martin, Copernicus and the French thinker of the infinities of the worlds, Bernard le Bovier de Fontenelle (* 1657; † 1757).¹⁷⁴⁹

15.3.4 Conclusion

The vacuum technique of Bošković's days was welcomed at the Jesuit physics lessons in the schools of Catholic countries, including those in the white city of Ljubljana. The operation of vacuum pumps was clearly effective, and Aristotle, Descartes, or Leibniz did not rightly question the durability of empty spaces, although the totally void spaces were still beyond any experimental reach. The facts did not fit in with the theory, and Hegel's "so much worse for the facts" was without chances because the brave Hegel was born only many years later. Bošković was the first to discover the Ljubljana and other Jesuit's best ways, according to which the vacuum can be

¹⁷⁴⁴ Džamanjić, 1768, 1: 2: 70–72.

¹⁷⁴⁵ Džamanjić, 1768, 1: 11.

¹⁷⁴⁶ Džamanjić, 1768, 2: 46.

¹⁷⁴⁷ Džamanjić, 1768, 2: 54.

¹⁷⁴⁸ Džamanjić, 1768, 2: 57–58.

¹⁷⁴⁹ Džamanjić, 1768, 2: 26, 66.

¹⁷⁴¹ Džamanjić, 1768, 1: 6.

¹⁷⁴² Džamanjić, 1768, 1: 7, 2: 54.

¹⁷⁴³ Džamanjić, 1768, 1: 8.

incorporated into Aristotle's doctrine using point centers of forces that led Bošković's heirs to a vacuum telescope and to a well-conceived vacuum balloon. While the first idea has been tested after a century as it has experienced its epilogue in Victorian Airy's England, the other is still waiting for new inventors of modern graphene-like materials that could successfully resist high pressure differences along the surface of the vacuum balloon. It may be waiting in vain, but nothing can be said for sure without a gypsy's divination, as the funny Italians say: if it is not true, it is at least well-founded (se non è vero è ben trovato).



Figure 15-14: Bošković's Street in modern Milan, not far from the former Bošković's observatory in Brera (photo: Taisa Štupar)

15.4 Ljubljana Native's Vacuum Books in Brussels (On the 300th Anniversary of the Birth of Janez Karl Philip Kobencl)

15.4.1 Introduction

Among the many people of Ljubljana, who at various times and in various circumstances excelled themselves in Brussels, the greatest star was Bošković's most trusted best friend, Count Janez Karl Filip Kobencl. Janez Karl Filip Kobencl was born in the middle of July's heat three centuries ago in the recently built Ljubljana Kobencl's palace; at Novi trg 4 it is now used by the ZRC SAZU. His success will serve well for his descendants as an example of how a learned member of a small nation from a relatively small

city should be established in the greater world. Kobencl, on the contrary of many of his Carniolan colleagues has proudly proclaimed himself as a Slovene, at least for the attractions of his student matriculations. Many scientists and researchers of vacuum technologies of their time, especially Ruder Bošković and Janez Krstnik Paccassi, enjoyed the friendly support of the mighty Kobencl.

15.4.2 Kobencl and Coronini for Bošković

The Kobencl and Coronini families were closely linked. The nephew of the Brussels minister Count Janez Karl Filip Kobencl, the son of his older half-sister Cassandra Kobencl was the Gorizia native Rudolf Antonio Maria Coronini (* 1731, Gorizia; † 1781, Gorizia). Until 1752, he studied at the ten years previously established elite Viennese Theresianum. His professor of mathematics was Erasmus Frölich; after Frölich passed away, his prefecture of library was taken over by the physicist and vacuum researcher Joseph (Jacobus) Khell von Khellburg. Khell's books, full of sketches of vacuum experiments, were also extremely popular in Ljubljana. In 1756, Rudolf Coronini participated in geometric measurements to determine the boundary between the Habsburg Monarchy and Venice following Bošković's methods just before the first visits of Bošković in Gorizia and Ljubljana; Rudolf Coronini and colleagues compiled a map of Gorizia and Trieste, which was reprinted after Bošković's visits, in 1759. In 1772, a student from Gradišča (Gradisca d'Isonzo) Girolamo Pisanelli bound his examinations at higher Jesuit studies in Gorizia with a book of Rudolf Coronini which was first published in Vienna in 1769. Frölich's student of mathematics, the former Jesuit Johann Michael Denis, was assisted by the experienced Jesuit Andreas Friz (* 1711; † 1790, Gorizia) in his Latin poetry compiled for Coronini's Viennese edition. On 8 September 1780 Rudolf Coronini founded the Accademia degli Arcadi Romano-Sonziaci to become its member with the academic name Lebanio Crissanteo. The other distinguished academicians were Peter Anton Codelli as the ancestor of the later Ljubljana inventor of the vacuum elements of television, the former Jesuit students and Roman Arcadian member Giuseppe Coletti and the president of the academy Rudolf Coronini's uncle Guido Kobencl. Of course, the

older uncle of Rudolf Coronini, Guido's brother Janez Karl Filip Kobenzl, kept Rudolf Coronini's works in his Brussels library.

Rudolf's sister Ludovica Coronini married Rudolf Strassoldo de Villanova; their brother, Ernesto Felice Coronini, taught philosophy with physics and modern vacuum techniques at Jesuit high schools in Gorizia. According to the legend, their ancestor Cipriano Coronini (Giovanni, (1500–1597) met Ignacio de Loyola in Rome, and he with his descendants helped Kobenzl to settle the Jesuits in Gorizia and other places in 1615.

15.4.3 *Technique of Guido Kobenzl, Younger Brother of Brussels Minister Janez Karl Filip Kobenzl*

In 1747, Guido Kobenzl moved from Ljubljana to Gorizia, where his older half-sisters Kassandra and Maria Elizabeth were richly married to the Counts Coronini and Edling. Guido, as the first president, helped to establish the *Accademia degli Arcadi Romano-Sonziaci* in 1780, which immediately became the official branch of the Roman Arkadians, founded a century earlier in honor of the Swedish Queen Kristina. The secretary of the Gorizia branch of the Academy was Giuseppe de Coletti (* 1744, Rome; † January 1815, Trieste) from the Florentine family, a former soldier and a printer. On 2 July 1784, Coletti began to issue *Osservatore Triestino*; he kept his editorship afloat throughout Napoleon's era until he calmed down forever. The brother of Gabriel Gruber's assistant the Jesuit Jožef Jakob Maffei was a Trieste patrician Karel Maffei. At the end of 1784, Karel Maffei became a member of the Trieste branch of the *Accademia degli Arcadi Triestini* under Coletti's leadership.

Guido Kobenzl has widely contacted several scientists. In 1753 Bianchini wrote to him about the underground flow of the Karst river Timavo; in the meantime, he rightly emphasized the "Guido Kobenzl's knowledge of the sciences of physics and mathematics".¹⁷⁵⁰ In a second letter to Guido Kobenzl, Bianchini described the spring and underground flow of Timavo in Videm (Udine) on February 4, 1754. As early as in September 1602, the Devin Servite monk Pietro Imperati described Timavo as linked to the River Recca in a message

¹⁷⁵⁰ Bianchini, 1754 *Osservazioni*, pp. 81.

sent to the Bolognese naturalist Ulisse Aldrovandi. Bianchini reported to Kobenzl about the underground voids resembling vacuums; besides the caves around Timavo, he mentioned Nile and other famous rivers. At first, Bianchini felt that the river under the Kobenzl's Predjama Castle was connected by the underground flow to Timavo; he carefully explored the karst caves to find an underground water connection with Cerknica Lake.



Figure 15-15: Guido(n) Kobenzl (Guodobald Cobenzl, * 1716; † 1797), the younger brother of Janez Karl Filip Kobenzl

Bianchini visited numerous caves in the Primorska region and finally found that only the river (Recca) flows underground into the river Timavo, which Gruber assumed after him.¹⁷⁵¹ Gruber realized that the drinking water of Timavo gets a strange taste when it blends with the earth on its underground paths between the coast and the sea.¹⁷⁵² He also sent the letter to Count Kobenzl in Gorizia. Gruber thoroughly examined the water regime of the Planinsko polje and the entire Inner Carniola (Notranjska) region, since it was of fundamental importance for his Ljubljana canal; he personally examined Cerknica and on that occasion described the Idrija mine.¹⁷⁵³

¹⁷⁵¹ Tavagnutti, 2000 *Giovanni Fortunato Bianchini*; Gruber, *Briefe hydrographischen*, pp. 157.

¹⁷⁵² Gruber, 1781 *Briefe hydrographischen*, pp. 157–158.

¹⁷⁵³ Gruber, 1781 *Briefe hydrographischen*, pp. 35; Korošec, 1967 *Beseda dve o Steinbergovem*, pp. 18.

On June 3, 1754, a friend of Gvido's brother Janez Karl Filip, Ruđer Bošković, wrote to Bianchini about his ten-year exploration of the Rimini port. At the same time, Bošković sent to Bianchini his 75-page long discussion on the Lunar atmosphere entitled *De Lunae Atmosphaera* and printed in the previous year.¹⁷⁵⁴ Among Bianchini's friends was also the researcher of Slovenian karst, the Anglican Bishop of Derry in Ireland, Hervey.¹⁷⁵⁵

15.4.4 Kobencl Supports Sciences in Brussels

Janez Karl Filip Kobencl studied at the University of Leyden during the late glory of the rector Boerhaave; near the University there was a famous workshop of Flemish brothers Musschenboek who, at that time, perhaps with the only exception of London, produced the best vacuum pumps and other devices worldwide. Janez Karl Philip Kobencl could not help himself, and he often went to see Musschenboek's headquarters.

Later, Janez Karl Filip Kobencl studied at the university in Würzburg; of course, he neglected moist kinds of the official exams and took over his studies in the style of the noblemen more as socializing until he became the suiter of Emperor Charles VI in 1730. As a real bon-vivant, he educated himself during his travels up to 1733. His carefree era was interrupted by his Viennese marriage with Marie-Thérèse de Palffy Erdödy (* 1719; † 25 December 1771), the daughter of the Countess Marie Margarethe Stubenberg (* 1694 Graz; † 28. 5. 1724) and Count Karl Paul III Palffy Erdödy (* 1697; † 1774) who became a Field Marshal on 5 July 1754. Marie Margarethe Stubenberg (* 1694) was the great granddaughter of the first cousin of the Protestant poet Johann Wilhelm Count Stubenberg (* 1619) who provided the first German translations of F. Bacon's books with a little help of the vacuumist Janez Vajkard prince Auersperg (* 1615), the owner of Gottschee manor. Johann Wilhelm Count Stubenberg was also a relative of Gera (Geria, Gerra) married to the baron Androcha, the owner of manor Kostel by Gottschee.



Figure 15-16: Janez Karl Filip Kobencl¹⁷⁵⁶

Janez Karl Filip Kobencl owned the castles of Prošek, Štanjel (St. Daniel), Jama, Ribnica, Planina, Šteberg, Logatec, Lože by Vipava (Leitenburg), Isernica, Sivigliano and Flambruzzo near Rivignano, halfway between Trieste and Venice, and others; for the tastes of the Hungarian reputation of his wife, he also carried the great cross of the order of St. Saint Etienne. According to the Emperor's Order (1751/59), he became a knight of the Golden Fleece together with the Parisian Ambassador Georg Adam Starhemberg;¹⁷⁵⁷ the same prestigious Argonautic Golden Fleece titles later belonged to Janez Karl Philip Kobencl's son since 1798 and nephew since 1792. In 1650, the early Golden Fleece order member became the first Prince Janez Vajkard Auersperg, the famous pioneer of Guericke's vacuum technique; he was followed by his heirs.

In 1738, Janez Karl Filip Kobencl became the authorized minister of Lorraine, the hereditary land of the husband of Maria Theresa, Franz of Lorraine, who was raised and tutored by the father of Janez Karl Filipe Kobencl. The tutorship did not prevent the Brussels quarrels among the emperor

¹⁷⁵⁶ Villermont, *Le comte de Cobenzl*.

¹⁷⁵⁷ Sorgeloos, 1984 *Charles de Cobenzl*, pp. 126;

Villermont, 1925 *Le comte de Cobenzl*, pp. 251, 252, 254, 277.

¹⁷⁵⁴ Marković, *Ruđer Bošković*, pp. 665.

¹⁷⁵⁵ Shaw, 2001 *Bishop Hervey*, pp. 286.

Franz's brother Karl and the son of the emperor Franz's tutor, Janez Karl Filip Kobencl.

Janez Karl Filip Kobencl became the first known Slovene freemason; he joined the lodge Zur Sonne in Bayreuth in 1741¹⁷⁵⁸ a decade after the reception of the freemason Franz of Lorraine in The Hague. The freemasonry was important part of vacuum research, since John Théophile Désaguliers (1683-1744) was among the most important researchers of new vacuum techniques: he was also the editor of the leading scientific journal of the London Philosophical Transactions and the leading freemason.

Janez Karl Filip Kobencl certainly inherited several books from his father, but he bought most of his collection himself. One of his favorite booksellers was the Normandy native Charles Fontaine (* 1724; † 1802), who founded the bookshop in Mannheim in 1742. Kobencl also bought books from Johann-Franz Varrentrapp (* 1706; † 1786), who established his bookshop in Frankfurt on Maine in 1731 and submitted 291 books to Kobencl between 14 January 1747 and 18 December 1752, including 130 books in German language.



Figure 15-17 Janez Karl Filip Kobencl's bust sculpted by of the Marseilles native Jean-Philippe-Augustin Ollivier (* 1739; † 1788) in Brussels

Janez Karl Filip Kobencl has hourly spread of his influence among the educators in Brussels, and his words also had a lot of power in the imperial court of Vienna. On 29 May 1767, Nény transferred to Kobencl the desire of the Antwerp printer, Jan Baptiste Verdussen III (* 1698; † 1773), that Kobencl should acquire the Jesuit Brussels library because of the expected ban of the Jesuits. The library was the most beautiful in the world, decorated by numerous discussions about vacuum techniques. Verdussen knew very well what was going on, since, with many incunabula, he kept paintings of Peter Paul Rubens and Antoine van Dyck. He was also a member of the Kobenz-based Brussels Literary Society, a later Imperial-Royal Academy. Kobencl immediately wrote back and accepted the offer as he really wished to acquire a nice picture of Antoine van Dyck.

15.4.5 Brussels Books

Janez Karl Filip Kobencl bought books for his home at the Mastaing Hotel in Brussels in numerous stores of booksellers from close ones and far. Janez Karl Filip Kobencl bought books for his home at the Mastaing Hotel in Brussels from numerous European booksellers close and far. On 22 March 1758, Michael Lambert recommended to Kobencl the *Journal des Sçavants*, the oldest European academic newspaper, which also brought some scientific -technical news. In Strasbourg, Kobencl bought books of Jean-Geoffroy Bauer († 1783), and in Vienna his bookseller was the royal imperial freemasonic printmaker Johann Thomas Trattner (1717 Jormansforf in Burgerland-1798). Kobencl amused himself with the *Journal Encyclopédique*, the *Mercure de France*, the *Gazette Britannique* and the *Gazette de France*; in fact, Kobencl's secretaries read that stuff for him. The canon Pierre Wouters (* 1702; † 1792), the royal librarian in Brussels between 1754 and 1768, bought books from sale for Kobencl, while Kobencl himself attended the Paris sales of the late marchioness de Pompadour (Jeanne Antoinette Poisson, * 1721; † 15 April 1764) and of the Jesuit library from the Saint-Paul-Saint-Louis Church on Saint-Antoine Road in the Marais district after the expulsion of the Jesuits from France in November 1764. In 1760, Kobencl intended to obtain the books of the impoverished Scottish Parisian researcher and a member of the Parisian Academy since 1750, Michel Adanson (* 1727, Aix-en-

¹⁷⁵⁸ Košir, *Brat Vega*, pp. 105.

Provence; † 1806) after his return from a five-year research in Senegal. His nephew, Cassandra's son Coronini, also brought the books on Kobencel's behalf. Janez Karl Filip Kobencel did not hire his own professional librarians-freemasons because his nephew Janez Filip Kobencel and his young secretary Gottfried Baron van Swieten (* 29. 10. 1733, Leiden; † 29. 3. 1803, Vienna) managed the catalogues for him. Gottfried Baron van Swieten was a son of physician of Maria Theresa Gerhard van Swieten, who was replaced by the freemason Jan Ingenhousz, researcher of Fontana's getting of vacuumed vessels and balloons. Between 1755 and 1757, since October 1757 under the control of Janez Karl Filip Kobencel (John Charles Philip), Gottfried served in Brussels in accordance with the courts' order. Gottfried later became the leading Habsburg diplomat dealing with the musicians and scientists, including the freemason Mozart and professor Balthasar Hacquet of Ljubljana; Mozart taught one of Kobencel's daughters to play piano. Janez Karl Filip Kobencel did not have the habit of writing or reading, but young secretaries preferred to do that for him, as he hired four or five secretaries together all the times.¹⁷⁵⁹



Figure 15-19: Arthur Devis (* 1712; † 1787) painted John Bacon, his family and pneumatic instruments maker Stephen Davenport's (* 1701) table vacuum pump designed in 1737 (oil on canvas in 1742/43, with the courtesy of the Yale Center for British Art in New Haven, Conn.)



Figure 15-18: Joseph Wright of Derby (* 1734; † 1797): The presentation of a bird's suffocating experiment in a vacuumed vessel of 1768. The type of depicted pump still raises a dust (oil on canvas, with the permission of National Gallery, London). The picture followed the style of the industrial revolution, which was promoted by the Ljubljana-native Janez Karl Filip Kobencel in his home gallery, one of the best in the world for decades.



Figure 15-20: Stephen Davenport's Business card with a vacuum pump in the foreground issued in 1721.

Karl Janez Filip Kobencel's nephew-secretary Janez Filip Kobencel (* 1741) compiled one of the catalogs of Karl Janez Filip Kobencel's (* 1712) library after he studied under supervision of Viennese Piarists. His exam was crowned by Bošković's praise and there was some hot chocolate involved. Before 1739, Karl Janez Filip Kobencel's stuff compiled the first of the two library catalogs finished during his lifetime on ninety-four folio pages between today's lost covers.

¹⁷⁵⁹ Sorgeloos, 1984 *Charles de Cobenzl*, p. 125; Villermont, *Le comte de Cobenzl*, p. 7, 8, 22, 88–89, 186, 216–217, 221.

Another author's catalog was created in 1761/62 on 149 folios. Each note had an Arabic number between 1 and 2000¹⁷⁶⁰ referring to the third catalog with a chronology of purchases, which is not in the record today. Janez Karl Filip Kobencl restored the library of the Duke of Burgundy (Bourgogne) in 1755, and in 1769 he strongly supported the establishment of the Société littéraire in Brussels, which became the Imperial Royal Academy of Sciences and Arts after his death, on December 16, 1772, with the help of a librarian in Leuven and later Bishop of Antwerp, Cornelius Franciscus Nelisa uit Mechelen (* 1736; † 1798).

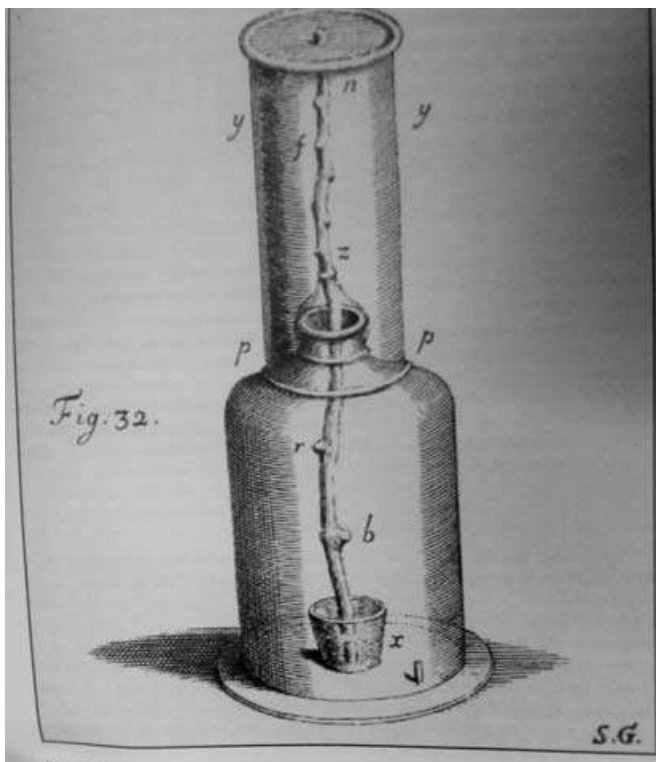

Figure 15-21: Vacuum container of English preacher Stephen Hales (* 1677; † 1761). On a plate that has a connection to a vacuum pump, a glassy vacuumed vessel is installed, in which Hales tested the permeability of the crust of a plant in a vacuum.

After the death of John Charles Philip Kobencll, the curator of his estate, Nicolas-Joseph Sanchez baron d'Aguilar (1739-1822), lawyer of the Brabant, listed the deceased's library along with birds, barometers, thermoscopes, hydrometric devices, a pump and thirty-six portraits of the English royal family. The sale of Kobencl's books

was entrusted to the librarian Joseph Ermens (* 1736; † 1805), who compiled a sales catalog separated in five professional fields including theology, law, science of arts, literature and history in February 1770. The sale was conducted on June 21, 1771 under the direction of the printer Henri Vleminckx. Samuel Paterson (* 1728; † 1802) published the English sales catalog of Kobencl's books in London next year, mixed with the legacies of other Dutch collectors; this was only partly an English translation of the Brussels offer, and later the prices of individual books were manually added in Paterson's printed text. Ermens has deployed 2821 books into ten expert groups. He collected nine incunabula and 80 editions from the 16th century. Around sixty books in the library of Janez Karl Philip Kobencl or 3.75% of the entire library were dedicated to mathematical–sciences with vacuum techniques included. Kobencl collected six books with mathematical content, three about astronomy, seven on physics, one on chemistry alone, one on anthropology, seven on general science, one on botany, three on zoology, twenty-three or twenty-two on medicine, four on mechanics or engineering, eleven on agriculture, four on the domestic economy and twenty-eight on military sciences.¹⁷⁶¹

The Brussels's political rival of Charles Philip Kobencl, the brother of Emperor Karl of Lorraine, went a bit deeper into technical sciences. He acquired 34 books on mathematics, 17 for astronomy, 38 about physics, 60 on alchemy-chemistry, 22 for geology, 25 on mechanical tools and engineering.¹⁷⁶² Karl of Lorraine received 36 books about science from the Mariemont's library in 1777, which provided 7.37% of all books which Karl's owned then. Karl had 47 books about sciences in the times of his death in 1780, which was 9.45% of them all. He had ten books of Hungarian writers, but only one of American, Bohemian, Chinese, Persian or Arabic authors. At the census upon his death in 1780, Karl of Lorraine had the books of Sigaud de la Fond, Jacques Rohault and Pulian. In Brussels Karl of Lorraine read about a physics of vacuum; he read the chemistry of Nicolas Lemery and Pierre Joseph Macquer, two copies of Diderot's Encyclopedia, the work of Valmont de Bomar on natural science, the books of Duhamel du Monceau, de Condamine, the French Jesuit Jean-Baptiste Du

¹⁷⁶⁰ Sorgeloos, 1984 *Charles de Cobenzl*, p. 126–127; *Bibliothèque Royale, cabinet des Manuscrits*, manuscrita no. 20.922 in 20.919.

¹⁷⁶¹ Sorgeloos, 1984 *Charles de Cobenzl*, p. 192–193, 199.

¹⁷⁶² Sorgeloos, 1984 *Charles de Lorraine*, p. 834.

Halde (1674-1743) and the similar ones, which were also read by Žiga Zois in Ljubljana. Lemery, Condamine and Diderot were not missed in the library of Janez Karl Filip Kobencel either. Karl of Lorraine had a relatively large useful collection of 255 manuscripts, including drawings of electrical appliances in connection with vacuum techniques, chemistry and porcelain production, various mysterious writings including medical and chemical manuscripts of Paracelsus.¹⁷⁶³ Karl used to read Nurnberg based natural science journal *Délices Physiques* (1766/67) produced under the pen of George Wolfgang Knorr, which Kobenzl also read. Karl used the South American *La Metallurgie* of Alvarez Alonz Barba in the Paris edition of 1750 and the Jesuit Jean Paulus' *Descriptio d'une machine astronomique*, printed in Point-à-Mousson in 1762.¹⁷⁶⁴ Jean Paulus arrived in Brussels in 1763 as a watchman of Karl of Lorraine and an engineer; he used modern vacuum techniques. He created Karl's clock and made another astronomical watch for the Brussels city's needs.

On 14 April 1759 the fee-thinker Janez Karl Filip Kobencel regretted the prohibition of Parisian Diderot's *Encyclopedia* as the continuation of Londoner work of Ephraim Chambers. Kobencel corresponded with Voltaire through bookshop Johann-Franz Varrentrap; Kobencel and his wife were a true Voltaire's admirers. They collected forty-one Voltaire's works and thirteen books about him. In 1759, Kobencel praised the book *Candide ou l'optimisme* issued anonymously in the same year of 1759. There Kobencel recognized the Voltaire's pen. He also had Voltaire's *Elémens de la philosophie de Newton, mis à la portée de tout le monde*, M. de Voltaire, printed in Amsterdam by J. Desbordes in 1738. Voltaire's essay on the nature of heat *Essai sur la nature de feu, et sur sa propagation* (1737), written for the prize competition of the Parisian Academy in 1739, was not published in Voltaire's collected works from 1739 and 1748, but only in 1757/58 at Cramer's office in Geneva; Kobencel bought it there. Kobencel also read the economic works of Bošković's friend the physiocrat Victor de Riquetti Marquis de Mirabeau published in 1761 and 1768. Among the summaries of the exact sciences, Kobencel loved Pierre-André d'Héguerty count Magnières's (1700-

1763) *Remarques sur plusieurs de commerce et de navigation* from 1757. He was particularly interested in Buffon's *Histoire naturelle* in the Paris edition of 1749 and in Hamburg's first German translation of 1750. Réaumur's friend, the former Oratorian priest Joseph-Adrien Lelarge de Lignac (1697 Poitiers-1762) immediately after the translation of Buffon's book into German language in Hamburg in 1751 published devastating critique of Condillac and Buffon entitled: *Lettres à un Américain sur l'Histoire naturelle, générale et particulière de M. Buffon*. Kobencel, of course, immediately bought the item. René Antoine Ferchault de Réaumur also criticized the encyclopaedia of Diderot and d'Alembert as the pure plagiarizing, which was certainly not entirely true. The freemason Benjamin Franklin supported Buffon's side.

Kobencel also read the Parisian *Dictionnaire raisonné universel d'histoire naturelle* of 1764, written by the pen of Jacques-Christophe Valamont de Bomare (* 1731; † 1807). Kobencel also kept the fifth edition of the Parisian *Elémens des mathématiques*, perhaps acquired already during Kobencel's youthful journeys. That Bernard Lamy's book was published by the Parisian widow Delaulne in 1731. In the same year under the similar title the fans of Jesuit Pierre Varignon (* 1654, Caen; † 23 December 1722, Paris) posthumously published Varignon's mathematics in Parisian offices of Brunet. In 1688 Varignon became the member of the Geometric Department of the Parisian academy and professor of philosophy at the Collège de France where he promoted his invention of U-tube manometer capable of measuring rarefaction in gases.

The second Amsterdam edition of Lamy's mathematics from 1682 was also kept by Baron Erberg in Ljubljana and later in Dol. At the age of eighteen, Lamy began studying in Paris. Four years later, while he was learning rhetoric (last year of lower studies), Malebranche met him and remained his friend until his death. In 1671 and 1672, Lamy taught philosophy at a college in Saumur and then in Angers. In Angers he defended then still banned Cartesian philosophy against vacuum, therefore the king Louis XIV has removed him in 1676. After four years of exile, he continued his teachings in Grenoble. In 1679 he published a mechanics with the rule for summing forces in a parallelogram, which was at the same time described by

¹⁷⁶³ Sorgeloos, 1984 *Charles de Lorraine*, p. 830.

¹⁷⁶⁴ Sorgeloos, 1984 *Charles de Lorraine*, p. 825, 827–828, 830, 832; Kobencel & Paterson, *A catalogue*, p. 88.

Varignon. Lamy's book was so popular that it was reprinted in 1687 at the time of the publication of Newton's Principles. In 1685, Lamy supplemented his mathematical textbook with geometry. The following year he was granted permission to return to Paris, but because of theological contradictions he left for Pascal's Rouen in 1690. There he published a paper on the perspective in 1701.¹⁷⁶⁵ After his death, Lamy's mathematical-physical works were published in Amsterdam in 1734.

L A
M A N I E R E
D'AMOLIR LES OS,
 E T
DE FAIRE CUIRE TOUTES
sortes de Viandes en fort peu de
temps, & à peu de frais ;

A V E C

Une description de la Machine dont il se faut servir pour cet effet, ses propriétés & ses usages, confirmées par plusieurs Expériences.

Par M^r. P A P I N , Doct. en Medecine, & Membre de la Société R. de Londres.

Nouvelle Edition revüe & augmentée d'une Seconde Partie.



A AMSTERDAM,
 Chez HENRY DESBORDES, dans le
 Kalver-Straat, près le Dam.

M. DC. LXXXVIII.

Princeton University
 Library

Figure 15-22: The cover page of the first part of Papin's book on vacuum technologies and the high-pressure pot that was read by the Ljubljana native Kobencl in Brussels

Janez Karl Filip Kobencl kept Jean Hellot's French translation of the work of the German Christopher-André Schlüter De la Fonte des Mines des fonderies, des grillages, des fourneaux de fonte, affinage, de raffinage, des fabriques de vitriol, de potasse, etc., printed in Paris between 1750 and 1753, which he had been using to advance the technology and economy of the Habsburg Netherlands. He also acquired a very influential Haller's *Elementa physiologia corporis humani* (Lausanne, 1757-1766). For a general overview of novelty in science and vacuum techniques,

¹⁷⁶⁵ Cantor & Cajori, 1908, 4: 603.

Kobencl afforded the simple parts of *Le Spectacle de la nature, ou Entretiens sur les specificités de l'Histoire naturelle qui ont paru les plus propres à rendre les jeunes gens curieux et à leur former l'esprit*, printed in Amsterdam in 1743. It was first published in 1732 while Zois acquired the later edition of 1752. Kobencl also had the mythological astronomy *Histoire du ciel* (Paris 1740) which Carli used in Italian translation *Istoria del cielo*, while Zois acquired *La mécanique des langues, et l'art de les enseigner* printed in 1751. All those three successful books were written by priest Noel Antoine Pluche (* 13. 11. 1688 Rems; † 19/11/1761 Paris), a professor of rhetoric and a school rector in Rems. Pluche was never really a Newtonian; he preferred Abbé Joseph Privat de Molières' compromise between Newtonian physics and Cartesian vortices, while in fact Pluche criticized both, Newton and Descartes.

CONTINUATION
DU DIGESTEUR
 O U
M A N I E R E
D'AMOLIR LES OS.
 SECONDE PARTIE.

Contenant les perfections qu'on y a ajoutées, & les nouveaux usages à quoy on l'a appliqué: avec plusieurs nouvelles utilitez de la Machine du Vuide.

Eprouvées tant en Angleterre qu'en Italie.

Par M^r. P A P I N , Doct. en Medecine, & Membre de la Société R. de Londres.



A AMSTERDAM,
 Chez HENRY DESBORDES, dans le
 Kalver-Straat, près le Dam.

M. DC. LXXXVIII.

Figure 15-23: The cover page of the second part of Papin's book on vacuum technologies and the high-pressure pot that was read by the Ljubljana native Kobencl (Cobenzl) in Brussels.

Kobencel had at least two Leibniz's books, as well as works by Christian Wolff.¹⁷⁶⁶ The contemporaries used them for teaching physics and vacuum techniques everywhere in the empire including Ljubljana.

Among the most important works on early vacuum techniques obtained by the Ljubljana native Janez Karl Filip Kobencel, was the work of Denis Papin¹⁷⁶⁷ issued in the time immediately after Papin's work in the position of director of experiments at the Venetian Accademia pubblica di Science, a public academy, which Kobencel knew well. The Venetian academics acted on the model of the Royal Society of London, and mainly dealt with Boyle's vacuum experiments, in which Papin himself had a good share. Upon Kobencel's death, Papin's book was estimated to relatively low value. It was worth 1 florin and 8 coins (kreuzers). It brought many novelties from the then vacuum technique.



Figure 15-25: Denis Papin (* 1647; † 1712) in the best days

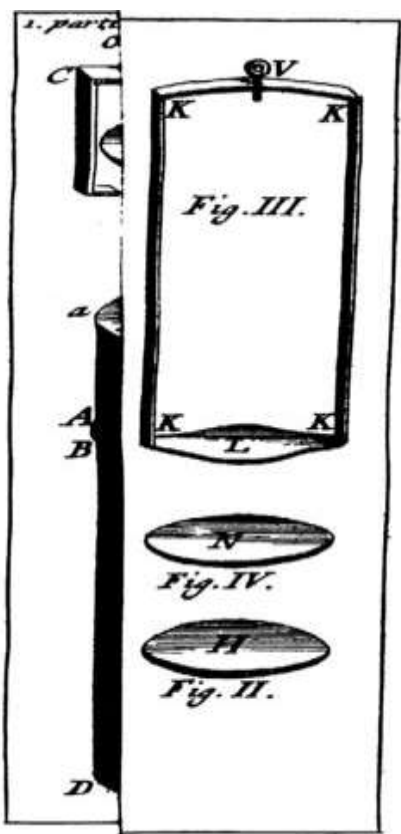

Figure 15-24: The Papin's container staged at the end of the first part of his 1688 book. It was used by Papin's reader Kobencel to host his famous guests.

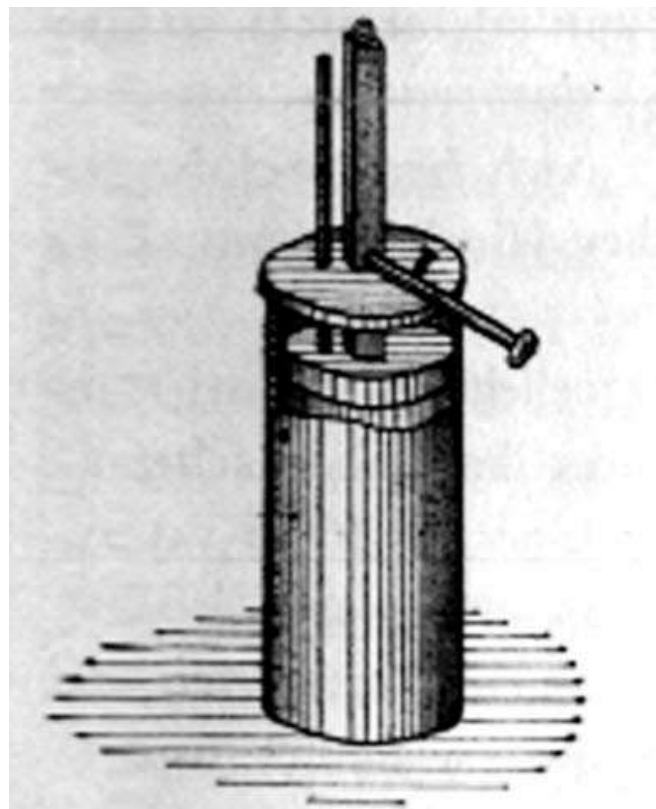

Figure 15-26: Papin's high-pressure cooker

Janez Karl Filip Kobencel obtained the book *Gründlichen Nachricht von dem in dem Inner-Crain gelegenen Cirknitzer See* of Franc Anton von Steinberg (* 1684, Kalec near Zagorje in the

¹⁷⁶⁶ Sorgeloos, 1984 *Charles de Cobenzl*, pp. 150–151, 156.

¹⁷⁶⁷ Kobencel & Paterson, 1772, 76, under no. 1848.

Karst; † 1765, Ljubljana), published in Ljubljana by Ana Elizabeth, the widow of Reichardt in 1758, on 235 pages with 34 copper plates. The book was distributed by Kobencl among friends. The Kobencl's catalogs mention as many as twenty-five copies of Steinberg's work, and one of them was given to Kobencl's co-worker, Nény. In the bookstore advertisement of the newspaper *Wochentliches Kundschaftsblatt*, Ljubljana's Promberger published one page with twelve new books he offered; among them was the booklet on the Lake Cerknica of Franz Steinberg for 1 fl. The provincial Governor Janez Gašper Kobencl encouraged Steinberg's work already between 1718/20; that is why Steinberg dedicated the book to Janez Gašper's son, Janez Karl Filip Kobencl, together with the seven pages of praise, and in 1761, Janez Karl Kobencl allowed the publication of a shortened translation at the Royal Press Office in Brussels under the title *Le lac merveilleux ou description du lac de Czirknitz en Carniole, et des ses principales singularités Phisiques. Tirés de l'allemand de Steinberg*. The work was dedicated to the Countess Kobencl on fifty-nine pages with a copperplate. At the same time the French translation and the reprint of the German edition were published in The Hague and in Graz. The Graz version differs from the Ljubljana redaction only by the publisher.

Steinbergs and Kobencls were ancient Inland cousins, although Steinberg's father was financially damaged by the loss of money invested in the breeding of Lipizzaner horses, so he had to sell his manor in Kalc and move to Cerknica Marof when Francis Anton Steinberg was only three years old. Steinberg's early textbook was N. Bion's masterpiece full of sets of measuring devices for vacuum and related experiments,¹⁷⁶⁸ with which Steinberg checked the operation of his inventions for the mine in Idrija. After his schoolings in Ljubljana, Steinberg studied mechanics, and he began to learn the modern vacuum techniques. Between 1712 and 1724 he was an official of the Imperial Court Chamber and the mining commission, then he became the investigator of forests, roads, and sea in Rijeka (Fiume) and later the supervisor of regional roads in Carniola. Between 1724 and 1747 he was the manager of the mine in Idrija, where he enriched the mining collection with many utensils based on modern

vacuum and watchmaking techniques; for many years Idrija was an unique capital of vacuum research because of the uses of Idrija mercury in barometers. Unfortunately, Steinberg did not understand well Scopoli, a physician who believed in the doctrine of phlogiston theory until the end of his days.



Figure 15-27: Title page of Paccassi's Book of Ballooning and Options for Their Vacuum Performance.

Janez Karl Filip Kobencl did not only help Carniolan writers. He even paid for the printing of the historical book by Robert Macquéreau de Valenciennes, edited by the Hebraist and bibliographer Jean-Noël Paquot (* 1722; † 1803) with a reference to Kobencl's name in the introduction. The nephew of John Karl Philip Kobencl, the Count Janez Philip Kobencl, aroused similar great ambition; he paid for the German translation of Euler's Latin papers on comets from 1744, which was translated by a jurist, diplomat, architect, astronomer, vacuumist and mathematician Janez Krstnik baron Paccassi. Paccassi collaborated with Gruber's teacher, Karl Scherffer and Abraham Gotthelph Kästner, whose

¹⁷⁶⁸ Korošec, 1967 *Beseda dve o Steinbergovem*, p. 16; Sevnik, 1988 *Steinberg*, pp. 458.

book Gabriel Gruber used during his lectures in Ljubljana. Paccassi was accepted into the Berlin Academy of Sciences just like Euler and Lambert; he also closely cooperated with them. Janez Baptist Paccassi translated the legal documents of French Finance Minister Jacques Necker (* 1732; † 1804) in Vienna in 1781. He was a descendant of court architect of Schönbrunn, Nikolai Frančišek Leonard Paccassi (Nikolaus Franz Leonhard, * 1716, Viennese Neustadt; † 1790, Vienna), who became a member of the Viennese Academy of Arts in 1768 and baron on 15. 7. 1769. The stonecutters Paccassi rose to European fame through their work for local Gorizia magnates including Coronini.

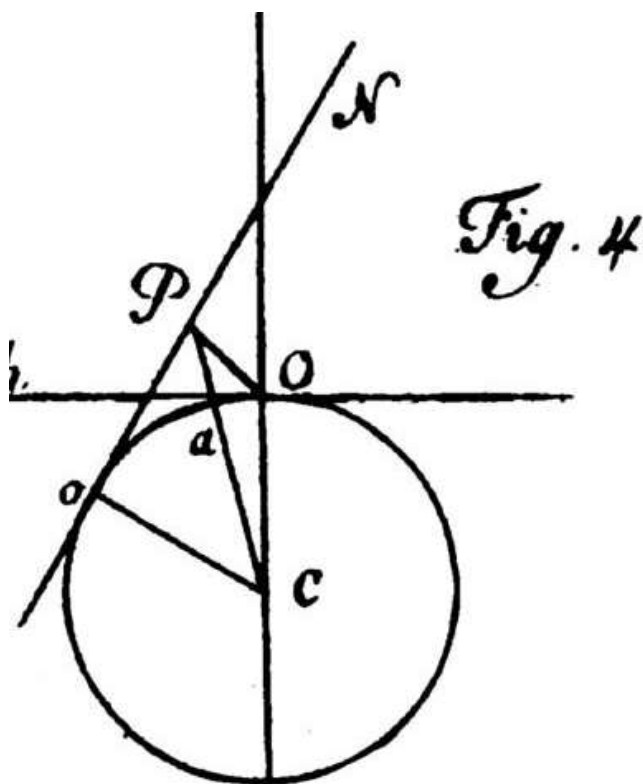

Figure 15-28: A picture at the end of Paccassi's *Book of Navigation* which discussed the filled and vacuum balloons

In 1784, immediately after the first French experiments by Montgolfier brothers, Janez Baptist Baron Paccassi published mathematical calculations of the possibility of directing flights with balloons; he judged them as impracticable, due to the thickened wall of the balloon, rejected the idea of the Jesuit Lana Terzi on a vacuum aircraft.¹⁷⁶⁹ He was thinking of an elliptical balloon and checked the resistance by the Euler's equations

¹⁷⁶⁹ Paccassi, *Bewegungen der Luftmaschine*, pp. 10–11.

of mechanics. He calculated a curvilinear movement of a balloon caused by changing of the external pressure along the path of the lifted balloon at the border of vacuum measured by a mercury barometer; in this case, the vacuum was formed above the column of Idrija mercury. By his first approximation he ignored influences of the gravity of adjacent planets according to the calculations of geologist Barthélemy Faujas de Saint-Fond (Barthélémy); he used Saint-Fond's French description of Montgolfier's flight, which was also read by Žiga Zois in Ljubljana, Faujas de Saint-Fond criticized the bad German translation of Franz Übelacker since Faujas de Saint-Fond was certain that Übelacker did not master modern mathematical and vacuum techniques.¹⁷⁷⁰ Janez Baptist Baron Paccassi also applied for the prize competition of the Parisian Academy focused on the piloting of balloons. Already during the printing of his book, he heard about the filling of balloons with carbon dioxide developed by the then vacuum researchers; the novelty was immediately offered to readers in his appendix.¹⁷⁷¹

The Kobencl family name without male heirs disappeared on the southern slopes of the Alps well over two centuries ago. Perhaps in their last two generations, a similar mistake has been made as in the last two generations of the Counts of Celje three and a half centuries earlier: they wanted to grasp as much political power as possible while forgetting all about the centuries of Habsburg wisdom: the power is retained with as many children as possible. Like the old Celje family, Kobencl's genus became extinct as they spent too much time in political intrigues instead of producing their own children, but by no means before they were magnificently written in the golden letters in the history of Slovenian diplomacy. In their time Celje rulers built their power on the accumulation of profitable manors, while Kobencl played on modern techniques, Freemasonry associations and on a high society of the Viennese policy itself. In contrast to the Celje rulers or the Auerspergs, the Count Kobencl never received the honor of prince, but they certainly did not regret that on the eve of Napoleon's abolition of the Holy Roman Empire of the Germanic nation with all its princes included. While the weapons of the Celje magnates were sabres, the Auersperg

¹⁷⁷⁰ Paccassi, *Bewegungen der Luftmaschine*, pp. 16, 20, 26, 27, 29.

¹⁷⁷¹ Paccassi, *Bewegungen der Luftmaschine*, pp. 32, 33.

swore to their good governance at the Lower Carniola (Dolenjska) region or the Sudeten region, and to vacuum experiments under Guericke's auspices. Besides their Inner Carniola and Littoral manors Kobenc's toolkit was mostly advanced up in the salons of the then social cream, where famous books about new vacuum techniques and other puzzles of the modern era were read and discussed.

15.5 Gian Rinaldo Carli - First Professor of Technical Sciences from the Area of Present-day Slovenia

15.5.1 Introduction

The Carniolan Count Kobenc can be placed along the side of the Count of Carli, who established themselves not far away from the state border in Venetian Koper. The high school, now known as the Gian Rinaldi Carli Gymnasium in Koper, was founded as Collegio dei Nobili in 1612 by Corpo de Nobili as a body of the Council of the City of Koper (Consiglio comunale). It was the first lay school in Koper; its initial purpose was to oppose Protestants in the spirit of the Tridentine Council during the awkward time after the devastating wave of violence called the Uskok War or the war for Gradisca (Gradišča); the fights ruined in Istria between 1615 and 1617 and impeded the functioning of the school along with infectious diseases, so that uninterrupted teaching operations began only in 1675.¹⁷⁷² The Somaschi fathers used the help of monks from other Catholic orders to administer their school in Koper. In 1676, Vincent Ferra from the Koper Dominican monastery taught the logic and philosophy in Koper. Immediately after the construction of the college building, between 1684 and 1687, mathematics and chemistry were taught in Koper by Franciscan trainee Michel Angelo Fardella (* 1650, Trapani, Sicily; † 2. 1. 1718, Naples). After entering the third Franciscan order (Order of Penance of Saint Francis) after three years of teaching became a priest in the year 1665. He studied in Messina with Giovanni Alfonso Borelli (* 1608; † 1679), a student of Benedetto Castelli and Galileo, who knew well then available vacuum techniques.

Fardella taught mathematics and theology in Rome after 1676. Between 1678 and 1680 he became a Cartesian opponent of the vacuum after talks with D. Cassini, Spinoza's critic Pierre Sylvain Régis (* 1632; † 1707), Antoine Arnaud, Nicolas Malebranche and Bernard Lamy. In 1680, he returned to Rome for his second time as a lecturer in the mathematics instead of the recently deceased vacuum researcher Kircher. He then responded to the invitation and in April 1681 began teaching the philosophy in Modena, where since 1679 he worked with Michele Angelo's half-brother Tommaso Fardella († 1694), a tutor of the marquis Bonifacio Rangoni, the first president of the Academy of Dissonanti established in Modena in 1683. Michel Angelo lectured on logic and mathematics in Modena in 1681/82; in 1682/83 he taught physics with chemistry and geometry, and in 1683/84 metaphysics, that is, the entire three-year course of philosophy. In 1683, he went back to Rome, where he published *Conclusiones (ad) mathematicae and polemized with Jesuit Giovanni Francesco Vanni about the experiments; in Rome he also published *Restitutee ac methodicae philosophiae et matheseos principie, and utiliores assertiones*. There in his *Prolusio* (introduction) he defended 222 scientific theses, arranged in seventeen sections, including astronomy, physics and the pneumatics as the knowhow about gases and vacuum. In 1684, with half-brother Tommaso, he went to Koper, where Franciscan trainee Michel Angelo taught for three years as a public lecturer in philosophy (physics and mathematics), while lawyer Tommaso Fardella was the rector in Koper between 1685 and 1689.¹⁷⁷³*

In 1685, Michel Angelo Fardella visited Rome, where he unsuccessfully tried to get the chair at a mathematical department of Sapienza University. Vitale Giordani (* 1633; † 1711) got that prosperous chair as he was also a friend of Borelli, one of the founders of the Florentine Accademia del Cimento in 1657, Michel Angelo Fardella taught in Venice between 1687 and 1709, where the commander of the city Fletre by Belluno northwest of Venice Almora Dolfin (Almorò) hosted him and his half-brother Tommaso Fardella. In Venice, in 1689, Michel Angelo Fardella as Cartesian had his hardest times with a local inquisition. He taught Astronomy and Philosophy in Padua as a unique predecessor of Gian Rinaldo Carli between 1693 and 1709, after becoming a secular priest. Between 1709 and 1713 Michel

¹⁷⁷² Žitko, 1994, 127–128.

¹⁷⁷³ Pusterla, 1891, 41.

Angelo Fardella was in Barcelona, and then returned to Italy. He was in contact with the opponents of the vacuum Leibniz after their meeting in Rome in 1690; this prompted Michel Angelo Fardella to reject the genuine criticism of Cartesians provided by the Matteo Giorgio in Genova 1695 and 1698. In 1691 Michel Angelo Fardella communicated two Natural Historic scientific books in Venice in Girolamo Albrizzi's (Albritus) edition, and in the following year he published the third one in Amsterdam in the office of Paolo Antonio Sanzonio. In 1698, Girolamo Albrizzi published anti-Cartesian views provided in the letters of Matteo Giorgio, Michel Angelo Fardella, and the physician of the pope Innocent XII (1615-1700) Luca Tozzi (1638 Frignano–1717 Napoli) in *La filosofia cartesiana impugnata in alcuni principi dal dot. Matteo Giorgi genovese, e difesa dal signor abbate Michel'Angelo Fardella professore d'astronomia, e Meteore nello Studio di Padova Consacrata all'illustrissimo monsignor Luca Tozzi medico di Sua Santità in Venezia*.

In 1986, in Naples Michel Angelo Fardella's fans reprinted his scientific opinions and letters against the Scholastics.¹⁷⁷⁴ The modern edition surely means that Fardella's ideas, developed in Koper, still have a notable echo.

The count Gian Rinaldi Carli was born two years after Fardella's death. A century after the founding of the Collegium of Nobles, Carli studied there. Differently from Fardella, he preferred Newton to Descartes. Carli was one of the most prominent erudite of Koper which is why his name is today used for the gymnasium with an Italian learning language in Koper. Another interesting feature is in the Gian Rinaldo Carli's networks: although his knowledge covered other major centers of northern Italy, he remained present in Koper himself as a not always quite successful entrepreneur, but above all a scientist, lover and collector of (good) books. There was already a lot of ink spent on Carli's work in various fields of humanities and economics. Here we describe his research on chemistry, physics and related fields which became his first love after he barely left the student bench and began to lecture on the newly established chairs for nautical sciences, ship architecture and astronomy with geography in Padua.¹⁷⁷⁵ Quite early, Carli accepted new scientific achievements

of his times, including modern vacuum pumps. He read the books of Keill, who was among the first to teach Newton's physics. The work of these famous men was already known to Carli in Istria, after Halley befriended Valvasor; between 1701 and 1703, Halley drove across Trieste, Istria and Kvarner, searching for suitable ports for the planned disembarkation of the English and Dutch Navy assisting Habsburg Emperor during the War of the Spanish Succession. In 1718 Halley assumed that the stars had changed their positions from the Argonauts' era.¹⁷⁷⁶ The young Halley once published Newton's Principles with his own money. Newton's work, and with it many other stars of contemporary science, could not wish for a better recommendation than offered by Halley. He was the captain of the English navy and a visitor of all kinds of fairs in Trieste, Rijeka or Istria, although he finally preferred to fortify Bakar Bay for the planned disembarkation. Thus, Newton's achievements after Halley's mediation in Istria have been well-known for two decades before Carli's birth. Nevertheless, Carli was honored as the first to write about modern physics, chemistry and vacuum techniques among the Istrian people; so, Carli was one of the first modern researchers not only south of the Alps, but also throughout the Continental Europe outside France.

15.5.2 Vacuum Techniques by Paduan Professor Carli

Less than three years after the end of his happy Paduan student days, Carli took up a newly established chair for the theory of nautical sciences and shipbuilding at the University of Padua with a salary of 300 florins on 21 April 1745. Marquess Scipione Maffei and Giovanni Poleni (* 1683; † 1761) have rearranged Paduan studies of mathematics with physics and chemistry and astronomy in Padua; At the suggestion of Giovanni Poleni, Jacopo Stellini and Marc Foscarini, the young twenty-five-year-old Carli was appointed professor at the newly established department. An aid to Carli's academic prestige was his publication, which made Carli's lectures interesting for the school of the Venetian arsenal. At the time of Carli's lecturing the university of Padua founded a chair for natural sciences (1734), experimental philosophy (1738) and the basis of

¹⁷⁷⁴ Fardella, 1691, 1695, 1986.

¹⁷⁷⁵ Del Negro, 1997, 153, 156.

¹⁷⁷⁶ Hoskin, 1978, 239.

geometry (1741); the latter worked only until 1751.¹⁷⁷⁷

Because he was so very young, Carli probably did not fully absorb his so-called academic duties,¹⁷⁷⁸ but nevertheless he took his scientific position in extreme seriousness; and consequently he published two of his most important books devoted to mathematical and natural sciences related to vacuum and magnetism.

As a new professor of mathematical and naturalistic technical (exact) sciences at the prestigious Paduan chair, Carli emphasized, of course, the areas of knowledge that he most praised. Particularly important was the use of magnets in compasses, tidal studies, the elimination of inaccuracies in clocks and the knowledge of the movements of the compass.¹⁷⁷⁹

Carli used the measurements of magnets of Thomas Savery's relative Servington Savery (* 1669; † 1744 Shilstone in Devonshire) published in 1730 in London's *Phil. Trans.* At the same time, he read the famous work of vacuum researcher Pieter Musschenbroeck *De Magnete*,¹⁷⁸⁰ which was also extremely popular in Ljubljana. Carli praised the works of Bernard Zendrini, a professor of mathematics from Venice, who compiled his own compass in 1714. According to Zendrini's example, Carli also designed his own version of compass in Padua.¹⁷⁸¹

15.5.3 *Carli and Tartini*

The Piran native Tartini corresponded with Koper native Carli. Tartini praised Bošković as the greatest mathematician in Europe. At the same time, Tartini corresponded with other important mathematicians of his time, although some of them were not friendly to him, nor to Bošković. Among the recipients of Tartini's letters were: G. Riccati, F. Algarotti, Jacquier, Le Seur, Lalande, d'Alembert, Beccaria, Nollet, and Euler. French professor of mathematics Le Seur of Parma and

Jacquier from the La Sapienza University in Rome were close associates of Bošković; they became famous with the commentary translated of Newton's *Principles*, published in 1739 and 1742. Tartini also shared the common friend Lalande with Italian defenders of Bošković; Tartini contributed greatly to the acceptance of Bošković's concept of the world and of the vacuum in northern Italy, which was short-lived. Carli was a genuine Tartini's friend, but Bošković was, nevertheless, Carli's political opponent during Carli's efforts to limit the Jesuit influence on high schools in Milano and Pavia.

15.5.4 *Electricity*

The modern science has already successfully attacked magic in the era of Carli. The Inquisition was also involved in the dispute as it penalized by the Lombard laws. Carli resolutely opposed magic and the beliefs in witches already as a student; his opinion was later aggravated against Kabbalists, Pythagoreans and Astrology. On 5 October 1743, Carli wrote to Tartarotti on artificial memory, a very popular topic of the then scholars. Girolamo Tartarotti noted his ideas in an annex to the collection of one hundred thirty-four magic observations; followed by the addition and letter of Congress (*Congresso Notturmo delle Lammie*), which were exchanged mainly by Clemente Baroni Cavalcabò (1726 Sacco in Trentino–1796 Sacco) and the Abbot Tartarotti from Rovereto in Trentino between April 1750 and April 2nd, 1751. In the first letter on 18 June 1749, Ludovico Antonio Muratori in Modena criticized the letter of Paduan professor Carli, sent to Tartarotti in 1749 and published in the documents of the Congress; Carli rejected the supposedly wrong doctrine of legendary mages from the time of Jesus's birth. On 8 July 1751, the Abbot Tartarotti dedicated his book to Francesco Giuseppe de Rosmini in Rovereto. Already in the introduction, he refused Carli's adverse opinion of the diabolic magic, which they discussed during the congress in 1749.

S. Maffei and Tartarotti exchanged views with their companion Bartholomew Melchior; their thinking was in many respects based on the still popular Del Rio's instructions to judges in witch-hunt processes. The Jesuit Del Rio strongly opposed magic; as the Dean of the Theological Faculty in Graz, he lectured on the Old Testament between 1600 and 1603. The work of Rio was read

¹⁷⁷⁷ Del Negro, 1997, 144.

¹⁷⁷⁸ Sangalli, 2001, XVIII–XIX, 47, 51; Hoyer, 1992, 18; Bossi, 1797, 70–71; Stancovich, 1829, 337, 339; Ziliotto, 1912, 229.

¹⁷⁷⁹ Carli, 1745, 3rd page of unpaged dedication.

¹⁷⁸⁰ Carli, 1747, 23.

¹⁷⁸¹ Carli, 1746, 83, 85–87; Carli, 1747, 20, 31, 33 (figure 5); Micelli, 2004, 180; Zendrini, 1715.

Table 15-1: Important scholars and writers whom Carli quoted in his book on the Argonauts in 1745

Name	Year of publication, title of the book, place of publication	page of Carli's quote
Cornelius Agrippa		50
Peter Apian		44
Aratus, Solensis (Ἄρατος ὁ Σολεὺς; c. 315 BC/310 BC Soli in Cilicia of today's Turkey – 240) as a Greek didactic poet. Hi), the antique writer	1589, <i>Phænomen. in Astron. Vet. Script.</i> (Astronomica veterum scripta isagogica Graeca & Latina) Heidelberg: Offic. Sanctandreas	28
Archimedes		56
Niccolo Bion	<i>Traité de la construction et des principaux usages des instruments</i>	55
Count Buffon	1749, <i>Historie naturelle, Paris</i>	XIII
	<i>Libro de' Cavalieri erranti</i> nicknamed <i>Tavola ritonda</i>	12
Philipp von Zesen (Filip Caesio, * 1619; † 1689)	1662, <i>Cælum Astronomico-poeticum, sive, Mythologicum stellarum fixarum,</i> Amsterdam: Bleu	4, 7, 19, 29
Natale Conti	1612, <i>Mythologia,</i> Geneva	7, 53
Abbot Antonio Conti	1726, <i>Réponse aux observat. sur la Chronolog. de M. Newton e Lettre de M. au sujet, d'un petit écrit intitulée Réponse ec.,</i> Paris	
Vicenzo Coronelli (* 1650; OFM, 1665; † 1718), geographer of the Venetian Serenissima	1693, <i>Epitome Cosmografica ...,</i> Köln: Poleti	34
Aesop		41
Valerio Flacco (Flaccus)		18, 74, 77, 89
John Flamsteed	1725, <i>Historia Cælestis Britanica,</i> London	29
Alberto Fortis	1771, <i>Saggio D'Osservazioni Sopra l'isola di Cherso ed Oszero,</i> Venezia: Gaspare Storti	(Carli, 1785a, 70, 74)
Pierre Gassendi		54
Halley		XIII, 47
Herodotus	<i>Epistola; Rursum in Chersonesum (in Crimea)</i>	18, 19, 76
Hipparchus		51, 94; (Carli, 1785a, 78)
Hippocrates		43
Philippe de la Hire	1735, <i>Tables astronomiques,</i> Paris	46
Homer		22, 86
Gaius Julius Hyginus (1st century)	1642 or 1670, <i>Poeticon astronomicon.</i> Leyden/Amsterdam	42
Keill		46
Athanasius Kircher	<i>Museo Collegio Romano</i>	81
S. Maffei		XI; (Carli, 1785a, 77)
Count Giammaria Mazzucchelli	1737, <i>Notizie Istoriche e critiche intorno ad Archimede,</i> Brescia: Rizzardi	56–57
Mela Pomponius		77, 84, 86

Giovan Francesco Pico Mirandola		50
Newton	1728, <i>La chronologie des anciens royaumes corrigée</i> , Paris	42, 45, 46, 51, 53, 57, 59, 60, 61, 140, 281
Abraham Ortelius	<i>Argonautica</i> . Antwerp	49, 79
Dionigi Petavio	1710, <i>Rationarum Temporum</i> , Leyden (reprints: 1720, Köln: SJ (NUK-25288); 1741, Verona: Berni (NUK-72356); Astrology in his work: 1627, <i>Opus de Doctrina Temporum</i> , Paris	42, 281
Paduan professor Alessandro Piccolomini (* 1508, Siena; † 1578)	<i>Della sfera del mondo</i> , Venezia (first printed atlas of stars published in 1540)	54
Gajus Pliny Secundus, senior (* 23/24)	<i>Naturalis historiae libri XXXVII</i> with astronomy in second and geography in third book (Pliny, 2009, 24)	82, 85
Plutarch	<i>De musica</i>	53
Giovanni Poleni		29
Eusèbe Renaudot (* 1613; † 1679)	1736, <i>De l'origine de la sphère</i> , Paris	54
Joseph Justus Scaliger, Leyden professor of literature	1680, <i>Propers. Luog Traiect. Rhen.</i>	88
Johann Scheffer	1654, <i>De militia navali</i> , Uppsala	19, 23
Janez Ludvik Schönleben	1681, <i>Annal. Carniolae</i> , Ljubljana	79
Sesto Empirico	1569, <i>Advers. Mathemat.</i> , Paris; 1718, <i>Non ligna admirantes</i> . Leipzig	45, 50, 57
Étienne Souciet		XIII, 46, 47
Strabon	1705, <i>Geografia</i> , Leyden	4, 55, 64, 82, 89; (Carli, 1785a, 80)
Brooke Taylor		46
Marcus Vitruvius Pollio		50, 53
Giannantonio Volpi, professor of literature in Padua		19

in Stična and elsewhere in the Slovene lands. The Cistercian, Janez Krstnik David Radio, wrote in 1776 his own ex libris "Ad Usum" into Tartarotti's report on Congresso Notturmo delle Lammie. Carli's friend S. Maffei published on magic in 1750 and 1754.¹⁷⁸²

After his academic problems in Padua Carli dealt with numismatics from a historical point of view, which soon led him to money and economy. By the mediation of Kaunitz and Firmian Carli got a high-ranking Milanese job. Although he was a contributor of the famous newspaper *Il Caffè*, for

¹⁷⁸² Trampus, 1997, 143–145, 147, 148, 150; Maffei, Tartarotti, Melchior, Cavalcabò, 1751, 1, 2, 46, 106, 225–268; Trampus, 2004, 8; Mlinarič, 1995, 787, 795, 796, 934

his different Koper native basic feelings, Carli soon came into conflict with the editor of *Il Caffè* Pietro Verri. Their quarrels also reflected the opposite views promoted by the administrations of Kaunitz and Firmian. In the high-profile *L'uomo libero*, which Carli finished in the spring of 1776, Carli, as Habsburg politician, rejected Rousseau and Verri. The first edition had a fictional place of printing put in Lyon; afterwards, that Carli's masterpiece went through numerous editions. Initially, Carli concealed his authorship to escape the quarrel. Similarly, in 1780, he attributed the wrong place of publication named "Cosmopoli" to his *Lettere Americane*, where he recounted again with Rousseau, later Parisian Mayor-Astronomer Jean-Sylvain Bailly (1736; † 1793) and Buffon. In 1792, in his *Della diseguaglianza fisica*, Carli

completely rejected the French Revolution. Between 1784 and 1793, Carli released his collected works in which he changed many of his two decades older ideas. In 1797 in Venice, Carli's *L'uomo libero* was reedited in such funny way that the former Carli's defense of absolutism suddenly transformed into an opposite defense of the Republicans.¹⁷⁸³

In the ninth volume of his collected works, in 1785, Carli also reprinted his letters about witchcraft under the title *Dissertazione epistolare sopra la magia e stregheria*, published by the Tartarotti's Congress of Notturmo delle Lamie in 1749.

Carli knew the research of blood and arteries, explored by the Paduan student Harvey and Haller in their experiments on adapted veins of the dead folks. Carli was interested in the experiments of the priest Felice Fontana, who directed Ingenhousz to the discovery of photosynthesis. Fontana's research of the getters opened a new page of vacuum technique.

Carli rhetorically wondered what gravity used to be before the works of Galileo, the weight of the air before Torricelli's vacuum experiments, the optical theory before Newton, the transpirations before Koper native Santorio or the blood circulation before Harvey? Carli believed that the theory of caloric designed by Adair Crawford explained the blood circulation. Carli admired experiments with distillation and burning of the vacuum researchers Boyle, Boerhaave and Hales. Like light, the heat, blood circulation, or even life itself are also dependent on motion. If we stop the movement, nothing is left to the vitalism theory of the blood circulation of the Modesta university professor knight Michel Rosa (* 1731; † 1812), explained in his five letters sent to Carli and published in 1781. In 1783, the Professor Scopoli of Pavia, a former Idrija doctor, translated Macquer's chemical dictionary by defending phlogiston, which allegedly could describe Crawford's theory very well; of course, everyone with Carli included was eagerly awaiting new contributions by Knight Rosa.¹⁷⁸⁴

Carli published his discussion of *Della memoria artificiale* about then very popular topics of

artificial remembrance on 22 March 1793 with Abbot Bettinelli from the Academy of the City of Mantova. Next year it was reprinted in the 19th volume of Carli's collected works. Carli there recalled the ancient Francis Bacon's thoughts on artificial memory. He also knew the views of Christian Wolff from 1738. He was interested in the opinions published by Gassendi, Plato, Epicurus, Locke, Locke's defender Abbot Étienne Bonnot de Condillac (* 1715; † 1780) and Pascal.¹⁷⁸⁵

Carli was aware that the animal's electricity travels through the body (Carli, 1794, 19: 68-69) By discussing the works of the professors of Volta and Galvani, Carli compared the electrical effects of Leyden jar with a heart stroke in his *Opuscoli scelti di Milano*; the cardiac stroke seemed to him to be very like a blow from the Leyden jar. He assumed that most of the body movements were due to electrical phenomena and are therefore influenced by external and internal weather phenomena, which Carli linked to the bad habit of the current doctors, prone to excessive leakage of the blood of their patients. Leibniz attributed a lot of movements to the vibrations undetectable by experiments of those days. They resembled the vibrations of the bell. On 6 October 1792, Carli's association between animal electricity and heartbeat was published by the secretary of the Società patriottica di Milano Amoretti under the title *Sopra l'elettricità animale, e l'apoplezia*. Carli was interested in Galvani's research of animal electricity, published in 1791. Carli also used Volta's discoveries in Pavia and the publication of Giuseppe Gardini at the Mantua Academy in 1788. Carli was aware that Aristotle and Pliny had already been researching animals that produce electricity; he particularly emphasized Maffei's experience described in 1731. He electrified a 64-year-old woman before the publication of Franklin's theory. Maffei was interested in the properties of phosphorus in connection with animal electricity.¹⁷⁸⁶

In a tenth part of his collected works, Carli published his researches on the Argonauts, and in 11th-14th parts of his collected works Carli republished his *Lettere Americane*. Dr. Hooke published *An Essay towards a Maschinel account*

¹⁷⁸³ Trampus, 2006, 465–466, 473, 475; Costa, 1997, 206.

¹⁷⁸⁴ Carli, 1782, 101, 215, 216, 234, 248, 250–251, 257, 258; Stancovich, 1829, 371; Carli, 13. 6. 1782, 265–266.

¹⁷⁸⁵ Stancovich, 1829, 381; Carli, 1794, 19: 3, 29, 45, 46, 48, 64–65.

¹⁷⁸⁶ Carli, 1794, 19: 73, 76, 395, 396, 399, 400, 404; Bossi, 1797, 239; Carli, 1794, 19: 395; Stancovich, 1829, 382.

of memory; Carli surely had in mind Robert Hooke, who really presented in front of the Royal Society on June 21, 1681. Hooke lectured on mechanically conceived artistic memory under the title *An Hypothetical Explication of Memory; how the Organs made use of the Mind in its Operation may be mechanically understood*, which was printed after Hooke's death in 1705. Malebranche, the knight Rosa, Volta and Galvani also thought of similar problems.¹⁷⁸⁷

15.5.5 *Upgrading the Education of Chemistry and Related Sciences in Lombardy*

Carli, together with his friend Botanist Vitaliano Carli, together with his friend the botanist Vitaliano Donati (* 1717, Padova; † 1762), explored the cave called Grotta Santa at St. Servolo (Sveta jama by Socerb Castle) with a nearby underground “church” not far from Carli’s native Koper. Carli examined those stalagmites and stalactites again later in his *Lettere Americane*. He discussed the phosphorescence of the sea by ideas of the French Nollet, whose prominent electrical experiments opposed Franklin's ideas. Carli commented Maupertuis’ works and the book of Vitaliano Donati published under the title *Della Storia Naturale Marina dell Adriatico: Saggio in Venice* at the office Francesco Storti in 1750.¹⁷⁸⁸

Luigi Giusti (* 1709, Venice, 1766), the Viennese minister of Italian affairs (segretario del dispaccio nel Dipartimento d'Italia a Vienna), proposed Carli as a president of the Magistrata Camerale de Milano in 1760 which was profoundly reformed in those days. In 1765, Carli in Vienna assumed the duty of Commendatore di S. Nazaro, and on 20 November 1765, with the appointment dated 10 December 1765, he became president of the Supremo Consiglio di pubblica economia and later the president of the new Chamber of Commerce (1771- 1780). Among his associates were Pietro Verri (1728-1797) and young Milan patrician Angelo Maria Meraviglia Mantegazza († 1766), who died within three months. After the lectures in Padua and the death of the Venetian doge Foscarini, the Venetian authorities somewhat resented Carli. Therefore, during next decades, he operated under the Hapsburg Squad in Milan in

leading administrative and economic positions. He also became dean of studies (Decano del Tribunale degli Studi) in Milan. At the same time, on 24 November 1765, under the chairmanship of Count Karl Joseph Firmian (* 1718; † 1782, Milan), they established the *Deputazione degli Studi per il riordino degli studi superiori*, whose members included later vice-presidente del Consiglio di Governo della Lombardia Austriaca the physician Niccolò Pecci, the historian Michele Daverio, Giuseppe Pecis (1716 Milan–1799 Cinisello) and Milan professor of medicine reformer of female obstetric Giuseppe Cicognini. Under their authority were both the Pavia University and the Milanese Scuole Palatine, which had four Chairs of Civilian Institutions, Rhetoric, Greek and Mathematics. They also had a chair for philosophy with chemistry and since 1753 for urban and provincial law. Carli also took over the duties of Regio Ducal Magistrato camerale. He therefore created a plan for the study of engineers based on modern vacuum techniques of steam engines and the reform of Italian public schools, of course all those under the Habsburg administration. On 10 September 1767, Carli was appointed the emperor's personal adviser in Vienna. From June 1764 until May 1766, Pietro Verri, together with his brother Alessandro Verri and Marquis Cesare Beccario in Milan at the office of P. Pizzolato published the famous magazine *Il Caffè: o sia, Brevi e varj discorsi già distribuiti in fogli periodici*. In *Il Caffè*, they also published the articles contributed by Baillou, and Bošković under the title *Estratto del Trattato astronomico del sig. de La Lande on 1. 4. 1765 in folio (number) 31 (Bošković, 1765 344-349)*¹⁷⁸⁹ Gian Rinaldo Carli wrote *Sulla Patria degli Italiani* and Giuseppe Colpani also published there. In 1766 Paolo Frisi published in *Il Caffè* his sufficiently modern essay on Galileo’s theory of tides *Saggio sul Galileo and Degl'influssi lunari*.¹⁷⁹⁰ The philosopher-jurist Cesare Beccaria published in the journal *Il Caffè* the foundations of the mathematical political economy with the *Tentativo analytico su i contrabbandi* (Beccaria, 1764/1766, 173-175).¹⁷⁹¹ The basic and advanced mathematics were taught

¹⁷⁸⁹ Gian Rinaldo Carli wrote *Sulla Patria degli Italiani* and Giuseppe Colpani also published there.

¹⁷⁹⁰ Bošković, 344-349; Frisi, 1765/66, 2: 27-44, 291-195.

¹⁷⁹¹ The teachers of the Milanese Palatine School were still strongly inclined to theology, despite the three engineering chairs, among which one was led by the Barnabite monk Paolo Frisi with his lectures on mechanics, hydraulics and architecture began in 1763.

¹⁷⁸⁷ Carli, 1794, 19: 69, 73, 78.

¹⁷⁸⁸ Bossi, 1797, 100; Stancovich, 1829, 345–346.

by the Jesuits Francesco Luini (Luino, * 1740; † 1792) and Bošković from the Breda Observatory. D'Alembert and Diderot's friend Frisi was a strong anti-clerical recruiter in serious disputes with the Jesuits. In 1767, the bishop Carlo Battista Barletti (* 1735, Roccage in Alessandria province; † 1800) arrived in Milan; with Carli's support he excelled by his experiments with electricity in favor of Beccaria and Franklin.¹⁷⁹² The Giunta degli Studi asked for amendments, among which Carli and son of Luigi Giusti, Pietro Paolo Giusti, collected the best ideas for the reform of the Faculty of Philosophy in the form of comments in 1767 and 1768. Both agreed that the physics of cosmological systems of the Franciscan professor Felice Marzari in Pavia should cease as it was obsolete; Marzari still insisted on Euclid and Aristotle and not on modern vacuum techniques. Marzari was probably a relative of a younger Natural historian Giovanni Battista Marzari (1755-1827).

Carli and Giusti focused their proposals on both Milan and Pavia schools and to the provincial gymnasiums, but they were not yet able to determine the real significance of physics lessons. According to Carli, cosmology should be taught as a history of science and no more as a prelude to many possible explanations of the structure of the world; the existence and essence of Aristotle's bodies should be replaced by modern mechanics.

In his proposals on 30 January 1767 and on July 21, 1770, Carli wanted to change only part of the mathematics-related studies based on his mathematical and engineering experiences of Padua. Pure mathematics should contain algebra and infinitesimal calculus; followed by a hydraulic engine data for civil engineers. The applied mathematics must use an infinitesimal calculus in astronomy and cartography, whereupon the lecture would be about the architecture and military machines. To the pure and applied medieval mathematics Carli added its third part containing Newton's physics lessons. Carli defended Newton's definition of mechanics, including the laws of motion and gravity, or questions about light, fire, and sound that were at the edge of the then research possibilities and only weakly verified by experiments. Carli's ideal professor of experimental or circus-oriented physics with attractive vacuum experiments was supposed to

coordinate his lessons under supervision of the professor of pure mathematics on a weekly basis: experiments were still more eye-catching exhibitions than a regular part of the lesson at that time. Carli's Newtonian philosophy of nature was still a part of general physics about the structure of matter while in the particular-experimental part of physics Carli noted all about the substances of heat, electricity, or light. Giusti even more furiously criticized Marzari's outdated science and represented a more medical reforming compared to Carli's engineering. Carli avoided separation of the physics of the inanimate world from natural science and chemistry, while Giusti incorporated into physics the physiology of the human body for the teaching of doctors. Carli's mode of teaching prevailed in France and Piedmont, while in Lombardy the medical tradition was at least equally strong and there were no domestic military-mathematical experienced teachers who could promote Carli's Newtonian vacuum novelties.

In 1771 in Florence Carli published his *Nuovo Metodo per le scuole pubbliche d'Italia*. He proposed the teachings of mathematics and geometry at Lyceum, lectures of astronomy at the academy, the curses of general and experimental-vacuum physics at universities, including the lectures of botany and medicine without specialization in mathematics.¹⁷⁹³ In the reprint from 1774 in Lucca Carli tried to repair the vacancies within the higher education that occurred when the Jesuits were abolished in the previous year.

15.5.6 *Carli and Bošković*

Carli's work on both sides of the Venetian-Habsburg border shows us a respectable enlightener guy who was openly accepted by the rulers of both sides of the border of Venetian Serenissima or Habsburgian eagle. Carli was not just an enthusiastic supporter of Newton; his approval was also welcomed by contemporary followers of Newton's thought, such as the American Freemason Benjamin Franklin, and to a much lesser extent Franklin's friend, Croatian Jesuit Ruđer Bošković, who, as a former Jesuit, did not fit in with Carli's novelties. Probably through

¹⁷⁹² Laguzzi, 2010, 100, 106.

¹⁷⁹³ Brambilla, 2000, 67; Brambilla, 1987, 346; Stancovich, 1829, 365–366; Carli, 1784-1794 *Delle opere*, Tomo XVII.

the Carli's academic library of Koper, Bošković's astronomical work came to the library of the Koper collegium of noblemen. Shortly before Carli's appointment in Milan, on 30 April 1763, Ruđer Bošković was elected as head of the mathematical department of the University of Habsburg Pavia. The successful transition of Bošković from the Papal Rome to the Habsburg Pavia was of utmost importance for physics and vacuum technology in the Habsburg hereditary countries, which adapted to Bošković's science hourly. Immediately upon his appearance as the professor at the University of Pavia under the Habsburg administration, Bošković recommended the purchase of books of Belidor, Wolff, Lacaille and Jacquier, which the Jesuits of Ljubljana also had. In 1645, Riccioli and Grimaldi unequivocally measured the distance between Modena and Bologna; Bošković nevertheless appreciated the Jesuit Riccioli's books and in 1764 commissioned the purchase of his works for the University of Pavia.¹⁷⁹⁴

Carli was the fan of Bošković's friend Franklin, the pioneer of electricity research. That is why Carli wrote the letter in the foreword to the Italian reprint of his Letters of Americans from 1781 to the Freemason Benjamin Franklin, and all Carli's collection of letters was printed by another Freemason, Lorenzo Manini of Cremona. The first unpagged letter on six pages was addressed to Franklin, followed by the introduction of the historian-archaeologist Camaldolese monk of Hermitic-Benedictine provenience Isidor Bianchi (1733 Cremona-1807). Carli mentioned the famous Parisian scholars the Ecuador meridian measurer Charles Marie de La Condamine (1701-1774) and Count Buffon. Carli knew the confusions about the famous Parisian academician Count Buffon data regarding the age of the Earth; Franklin worked closely with Buffon's fraction of Parisian Academy at various commissions of the Parisian Academy, including the refusal of the Mesmer's Science. Carli read American travelogues of Italian and other writers before he wrote his American letters.¹⁷⁹⁵

¹⁷⁹⁴ Marković, 1968–1969, 199, 493, 653, 654, 656, 660; Steinwehr *Der Königl. Akademie der Wissenschaften in Paris*, 5: 1750, 594; Riccioli, 1651, 84–87, 384–388; Wallace, 1984, 347; Heilbron, 1993, 187; Koyré, 1968, 102–107.

¹⁷⁹⁵ Trampus, 1997, 149; Carli, 1781–1783; Carli, 1781, third page of introduction, unpagged; Šmitek, 1997, 32; Carli, Albónico, 1988, 410, 419.

15.5.7 Carli's Books

In 1757, after inheriting his father's wealth, Carli got a house in Koper and a nearby property in Cerej (Carlisburg, Žburga). His heritage prompted him to set up his own company through the wealthy legacy of his wife, Paola Rubbi (* 1724; † 1749), who died after two years of their marriage. The sad widower Carli added the family name Rubbi to his own. In 1761, with large hopes he opened the Koper spinning mill. Unfortunately, in business, too many followed the fashion principles that did not pay special attention in the real economy. A lot of noblemen in Koper participated in Carli's company, because he worked with a lot of energy and exported his products through the port of Trieste even to the Netherlands,¹⁷⁹⁶ whose Catholic parts within the limits of today's Belgium and Luxembourg has been under the Habsburg Administration already for half a century.

They did not only successfully develop spinning mills in Venetia of that time, but also in the neighboring Habsburg lands of Carniola or Styria; they were closely associated with spinning schools, which, according to the Habsburg patent from the end of 1765, enabled the exploitation of a cheap teenaged labor force. Carli certainly knew that interesting way to socialize education and business, but this time his luck turned his back just in front of his domestic Koper threshold. In 1764, Carli decided to sell his own already completely impoverished factory to neighboring company of Francesco de'Mori and associates in an emergency. In sales, the poor Carli lost 640,000 lire in 1770 according to the amount he initially put into the start of the new company. The accident was also a lucky one, since he turned from the entrepreneur to a scientist again. Under the auspices of the Academy of Revivals in Koper, Gian Rinaldo Carli and Girolamo Gravisi opened a library for Koper erudite in 1760. By their mutual correspondence we learn how both Koper native scholars personally took care of the management of the book collection, which was one of the first public libraries in the today's Slovene territory, established over half of a century after the Library of the Academy of Operosorum in Ljubljana. Carli worked in the academy between 1757 and 1760, with the help of his brother Girolamo Carli,

¹⁷⁹⁶ Darovec, 2004, 144, 148, 150.

Table 15-2: Significant scientists whom Carli quoted in his American letters in 1781

Name	Year of publication, title of the book, place of publication	Page of Carli's quote
Pater José de Acosta (* 1540; SJ; † 1600)		245
Francesco Algarotti	1737, <i>Newtonismo per le dame</i> ; (1764–1765. <i>Opere</i> . Livorno: Catellini (NUK-2148)	(Carli, Albònico, 1988, 60)
Giovanni d'Alva, companion of Hernán Cortés' attack on Mexico	<i>Tavole Messicane</i>	234
Admiral Anson		412, 413
Baily (Bailly)		The second page of the unpaginated introduction
Francesco Bianchini (* 1662; † 1729), protomedicus in Udine ¹⁷⁹⁷		232
Bouganville	<i>Supplément au Voyage</i>	411, 417, 418, 420
Boulanger	1761, <i>Recherches sur l'origine du despotisme oriental</i> ; 1766. <i>l'Antiquité dévoilée par ses usages</i>	244
Count Buffon	1749, <i>Historie naturelle</i> . Paris	The second page of the unpaginated introduction (Carli, Albònico, 1988, 49, 50, 51, 52)
Admiral John Byron (* 1723; † 1786)		416
Philip Carteret (* 1733; † 1796)	<i>Philosophical Transaction (London)</i> volume 60	420
captain James Cook	Observation of the transit of Venus in 1769	423
Daeboulin, general tax loaner (<i>ferme générale</i>)		422
Dominique Cassini		243
Condamine	Travelogue of the expedition in 1726	The second page of the unpaginated introduction, 234, 248, 425, 428, 429, 430, 431
Philibert Commerson (* 1727; † 1773), Bouganville's companion on their tour around the world	Letter	426
Mathematician Carlo di Engora		234
Count S. Etienne		410
Franklin		Uvod

¹⁷⁹⁷ Micelli, 2004, 182.

Halley		244
Antonio Herrera y Tordesillas	1532, <i>Historia verdadera de la Conquista en nueva España...</i>	234; (Carli, Albònico, 1988, 37)
Cornélius de Pauw, the protégé of Frederik II of Prussia	1773, <i>Recherches philosophiques sur les Égyptiens et les Chinois par M. Dr P***</i> . Berlin: Decker (NUK-2721)	(Carli, Albònico, 1988, 50, 51, 52, 53, 56, 58; Šmitek, 1997, 28); 227, 233, 234, 237, 412, 414, 417, 420, 423, 428
Pliny		248
Plutarch		242
Abbé Guillaume Thomas Raynal	1781, <i>Tableau et révolutions des colonies anglaises dans là Amérique septentrionale</i> . Amsterdam: La Compagnie des Libraires; 1772. <i>Histoire philosophique et politique</i>	The second page of the unpaginated introduction
William Robertson (* 1721; † 1793)	<i>(The history of America)</i>	The second page of the unpaginated introduction (Šmitek, 1997, 28)
Magellan	1780. <i>Storia dell'America</i> . Pisa (NUK-DS II 83189)	412, 413, 414, 417, 423
Maire		423
Martino Martini	<i>Storia cinese / 1655, Novus Atlas Sinensis</i>	231
Pierre Louis Moreau de Maupertuis	1748, <i>L'Origine delle Lingue</i>	232
Antoine-Joseph Pernety (D. Petnetty)	1770, <i>Dissertation sur l'Amérique et les Américains: contre les Recherches philosophiques de Mr. Corneille de Pauw</i> , Berlin	423 a footnote under the line
Pietro Ravennate, Paduan professor	Writings dated on 10. 1. 1491	229
Ulloa		234, 248
Amerigo Vespucci		410, 419
Voltaire	1736, <i>Alzire ou les Américains</i> . Paris: Bauche	(Carli, Albònico, 1988, 53)

The difference in the attitude of school administrators to books or vacuum devices originates on the one hand from the method of procurement: in 1755, according to the plan of the Jesuit professor Bernard Ferdinand Erberg (* 1718 Ljubljana; SJ; † 1773 Krems), he acquired fifty-four instruments at one time at a relatively high costs, while his books were mostly bought individually. On the other hand, books usually have their years of issues printed. The school librarians are also interested in dated ownership entries in them, while any kind of dating of school vacuum and other devices has never been customary noted on tools themselves: at the very least, we have just some data about their purchases in catalogs.

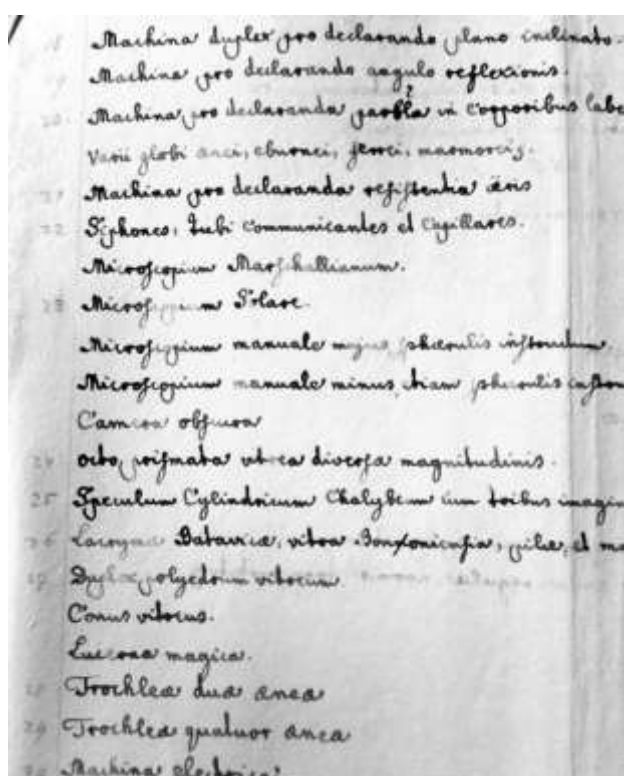

Figure 15-30: Bernard Ferdinand Erberg's inventory of 1755 made for the Jesuits of Ljubljana to finally fulfil the long-standing wishes of Empress Maria Theresa who ordered these modern purchases. The last page being the second page (Archives of the Republic of Slovenia, AS 6, Representative and Chamber for Carniola in Ljubljana (1747-1763), fascicle 40, box 121, I map) (Photography by the author with the permission of the Archives)).

The oldest comprehensive source for studying the teaching of physics and mathematics at the Jesuit College in Ljubljana is Erberg's Purchase List, dated on 17 September 1755. It was followed by a

list of all physical facilities in Ljubljana with Ambschell's signatures from 1779 and 1785. There are also some G. Gruber's acquisitions, A. Gruber and B. Schaller's catalogues. Kersnik's catalog from 1811 is also available in Ljubljana. By comparing the censuses and other data on vacuum experimental devices, we can assess the progress and direction of the development of experimental teaching of vacuum techniques at higher schools in Ljubljana.



Figure 15-31: Peternel's inventory of Bernard Ferdinand Erberg's devices from the year 1755 at the Ljubljana higher schools between 1850 and 1860 (Archives of the Republic of Slovenia, AS 6, Representative and Chamber for Carniola in Ljubljana (1747-1763), fasc. 40, box 121, I map, (Photography by the author with the permission of the Archives

15.6.1 Erberg

The Jesuits of Ljubljana may have hoped that they would not be forced in setting up a higher-level experimental cabinet, but that was not the case. Finally, on 17 September 1755, the baron Bernard Ferdinand Erberg compiled a list of fifty-four

unnumbered instruments for physics and mathematics studies at the Ljubljana semi-

university School; a century and a half later Müllner, accidentally listed only 51 tools.¹⁷⁹⁹ In course of the vacuum experiments, this started the modern physics in Ljubljana and, of course, it is still developing there.

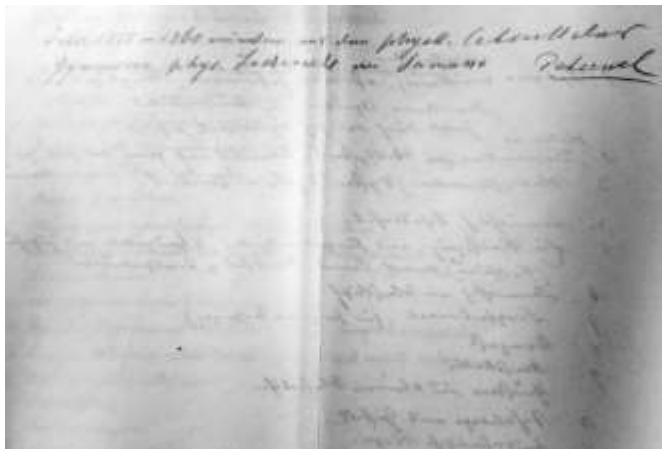

Figure 15-32: An explanation of Professor Mihael Peternel at the list of the then century old Bernard Ferdinand Erberg's devices from 1755 at Ljubljana higher schools (Archives of the Republic of Slovenia, AS 6, Representative and Chamber of Carniola in Ljubljana (1747-1763), fasc. 40, box 121, I map, (Photography by the author with the permission of the Archive))

15.6.2 Gruber's School Tools in 1768

On 26 October 1767, in Ljubljana at the founding general assembly, the foundation stone was laid for the Society for Agriculture and Useful Arts under the auspices of the then Provincial Governor the Count Heinrich Auersperg . On his mother's side he was a great grandson of the first vacuum vacuum researcher the Prince Janez Vajkard Auersperg. The Society was nicknamed Agricultural Society, although it was officially functioning under that name barely after the re-establishment following the Napoleon's fall. The patron of the Society was the respective provincial chief of Carniola; since 1769 the society was directly subordinate to the Provincial Governing Council. Until 1773, the first president of the Society was the councilor of the Provincial Governing Council, the commissar Josip Brigido

¹⁷⁹⁹ Müllner, Die Realistischen, p. 171–172; Schmidt, Zgodovina, p. 303; SI_AS 6, Repräsentanz in Komora za Kranjsko v Ljubljani (Chamber and representation, 1747–1763), fasc. 40, box 121, I map 17. 9. 1755.

von Brezovica (* 1736, Trieste; † 1817, Vienna). During the first two years of his term, his secretary (Schriftführer) was dr. Valentin von Modesti (1767-1769), the first permanent secretary of society (Sekretär) was Brigido's protege Hacquet from 1778 until the society lost its state support in 1787. Few months after Ž. Zois passed away, Janez Nepomuk Buset became the first president of the renewed Agricultural society in 1821.¹⁸⁰⁰

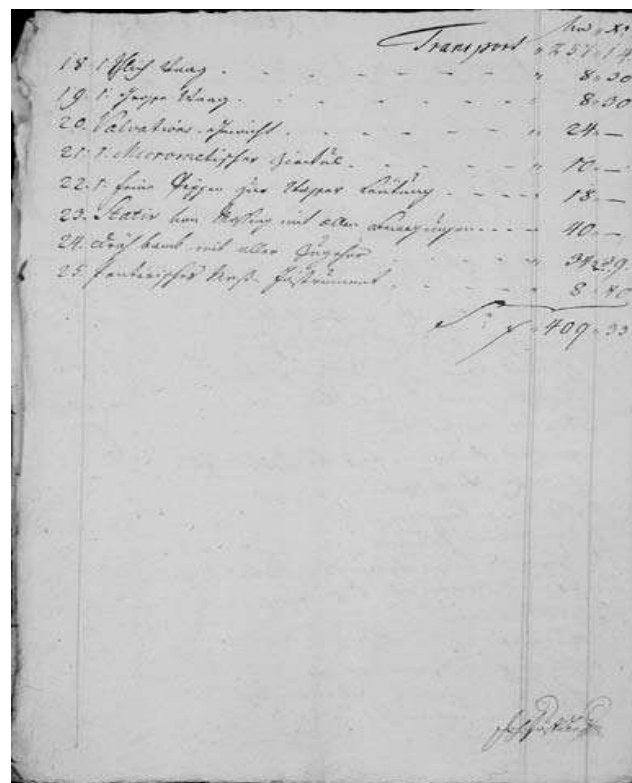

Figure 15-33: Gruber's acquisition of books and devices on August 31, 1768 (AS 33, Provincial Government, Convolute 455, Technical Unit 182) (Photographed by the author with the permission of the Archives)

An important part of the Society's activities was its support of the local secondary education, as the Society established Gruber's Chair of Mechanics in 1768, and in 1771 it established a chair for agriculture in the framework of Jesuitical philosophical studies. There Janez Nepomuk Giel taught. Gabriel Gruber was employed and probably also the first Ljubljana experimental physicist, Franc Mühlpacher (Mühlbacher, Mühlbacher, Millbacher, * 16. 10. 1744, Ljubljana; SJ 18. 10. 1760 Vienna; † 1826, Stanislavow (Ivano-Frankivsk) in today's Ukraine).

¹⁸⁰⁰ Reisp, 1989 O nekdanji knjižnici, pp. 38.

Table 15-3: Erberg's School tools for Vacuum experiments in Latin: "A list of Carniolan students' tools for free arts studies for the study of physics and mathematics at the Ljubljana grammar school in 1754 and 1755". A later German addition in the right-hand corner: "according to R. Bernard Erberg, SJ, Professor of Mathematics on 17 September 1755". Both mistakenly omitted Erberg's devices in Müllner's (1901) incomplete publication are written in bold. Peternel's German summary was added for his cabinet on then still existing Erberg's devices, which are preserved today at Erberg's census under the title: "From 1850 to 1860 physics classes in the collection of the Gymnasium Physics Department / Peternel" (AS 6, Representative and Chamber for Carniola in Ljubljana (1747-1763), fasc. 40, box 121, I map).

Erberg's device in 1755	Peternel's census 1850-1860	Field
16. Hydrostatic balance	11. Hydrostatic balance	mechanics of liquids
19. Aeolian harp with a rotating plate (the air blows on the strained strings)	12. Aeolian harp with Aeolian sphere (Heron of Alexandria) with punched whistles and circular chassis (reaction pump) designed for speech	mechanics-acoustics
20. Pneumatic Pumps with their own chest and a double bowl	13. Vacuum pump in a box with two circular plates (the third one has been seen since 1854 as an available specimen in the 8th class of Gymnasium on the iron stand); the same glass bells are used to ring in a vacuum.	mechanics-vacuum
21. Glass bell (to demonstrate the non-conduction of a vacuum exhausted by a pump (20))		mechanics-acoustics-vacuum
22. Bell for experiments (in vacuum, for demonstration) as above		mechanics-acoustics-vacuum
23. Glowing plate (to prove that the vacuum achieved with the pump described under no. 20 translated the rays of heat)	14. The pneumatic movement = the lighter, certainly the ancestor of the later Volta's invention	heat-vacuum
24a. A resinous mixture of silver and lead to show the porosity of the bodies 24. A resinous mixture of silver and lead (for sealing) to demonstrate when motion in a vacuum		mechanics-vacuum
25. Marble (plate) for (experiments with) cohesion 25a mixture of silver and lead for cohesion	15. marble adhesive plate	mechanics
26. Magdeburg hemispheres (for demonstration of air pressure)	16. known Magdeburg hemisphere	mechanics-vacuum
27. Heron's bronze fountain (where the compressed air raises the water jet)	17. Heron's burner	mechanics
28. The lighter for Pump	/	mechanics (optics) – vacuum
29. Barometer for meteorological observations	/	meteorology
30. universal thermometer for Meteorological observation	/	meteorology (heat)
36. Device for demonstrating air resistance	21. Device for proof of air resistance	mechanics
37. Siphon, communicating vessels and capillaries	22. Siphon, communicating vessels and capillaries	mechanics of liquids

On 20 April 1774, at a meeting of the Society Board they decided that three of society's members would travel through Carniola, collect material for the political history of the country, list the local natural resources, propose their exploitation and

experimental physics another former Jesuit Mühlbacher, who, however, is rarely found on subsequent lists of lyceum lecturers in Ljubljana because of the financial distress of his Ljubljana school patrons.¹⁸⁰³

Ausgaben zur Einrichtung
der Mechanischen Schule

<i>Praktisch. Architectura Hydraulica 18 Kupfer pl</i>	<i>34 40</i>
<i>Joseph Kaindlay des Kupfer 7 Blät 4h</i>	<i>42 -</i>
<i>Kupferne Aufzeichnungen 27 Blät 8vo</i>	<i>33 45</i>
<i>Praktisch. Geometrie 4 Blät 8vo</i>	<i>6 -</i>
<i>Praktisch. Werkbuch 4 Blät 8vo</i>	<i>15 -</i>
<i>Praktisch. Maschinen 4 Blät 8vo</i>	<i>12 -</i>
<i>Leica Zusammenbau des Kupfer 2 Blät 8vo</i>	<i>8 -</i>
<i>Leica Architectura 4 Blät 4h</i>	<i>5 30</i>
<i>Leica Baukunst 8vo</i>	<i>20 -</i>
<i>Maschinenbau Baukunst 8vo</i>	<i>12 -</i>
<i>Werk mit zwei Kupferpl. Kupferzange</i>	<i>5 -</i>
<i>Ein Kupferpl. des prussischen geometrischen Maßes</i>	<i>24 25</i>
<i>in Leder</i>	<i>20 -</i>
<i>Joseph von Wien Kupfer des Maßes</i>	<i>8 40</i>
<i>Praktische Messinstrumente</i>	<i>25 30</i>
<i>Ein Kupferpl. Maß</i>	<i>5 30</i>
<i>Kupferpl.</i>	<i>8 30</i>
<i>Ein Kupferpl. Maß</i>	<i>24 -</i>
<i>Praktische Geometrie</i>	<i>10 -</i>
<i>Praktische Geometrie Kupferpl.</i>	<i>18 -</i>
<i>4 Blät des Maßes zur Kupferpl. Maß</i>	<i>80 -</i>
<i>des des Maßes mit einem und zwei</i>	<i>80 -</i>
<i>des des Maßes mit einem und zwei</i>	<i>2 -</i>
<i>mit zwei</i>	<i>1 23</i>
<i>Kupferpl. des des Maßes mit einem und zwei</i>	<i>1 23</i>
Summa	420 33

G. L. O. Gruber

Figure 15-34: Gruber purchases of books and appliances on 28. 9. 1768 (AS 33, Regional Government, Convolute 455, Technical Unit 182) (Photographed by the author with the permission of the Archives))

multiplication. Among the three designated travelers were: Giehl, Mühlbacher and Hacquet, a member of the society since 1772;¹⁸⁰¹ their findings were later used by Linhart. On the initiative of the Society for Agriculture and Useful Arts, the new Department of Agriculture was approved in 1771; on 7. 5. 1774 Giehl received a (renewed) permission to teach after a ban on the Jesuit society. The students of theology and philosophy did not like to attend those additional agricultural school lessons, whole the farmers, of course, did not go to Ljubljana to listen to lectures about their own craft.¹⁸⁰² On 19 September 1774, at the same time with Giehl, the Carniolan agricultural society hired for the lectures about the

Table 15-4: Costs for instruction tools which Gruber proposed in the summer or autumn in 1768: »Inventory or determination of the use of books, devices, machines and models for the operation of Mechanical School of Agricultural Society established by the highest authority. Listed by the professor Gabrijel Gruber on 31 August 1768« (AS 33, Provincial government, convolute 455, technical unit 182) and again in the pamphlet on 28. 9. 1768: "Expenditure for Mechanical School Equipment" (AS 33, Provincial Government, Convolute 455, Technical Unit 182). The numbered tools listed in August are here presented as bold, and the editions of the September are in italics. In September instead of the original twenty-five expenditures for the total amount of 409 florins 33 kreuzers, Gruber proposed only twenty-three supplies for a total of 9 florins less, therefore, for only 400 florins 33 kreuzers. We list only devices that were also useful for vacuum experiments.

15. = 17. 28 florins (fl) 30 kreuzers (kr) Precise scales for experiments
16. = 18 8 florins (fl) 30 kreuzers (kr) Scales from lead
17. = 19 8 fl 30 kr High precision scales for measuring with one-pound weights
18. = 20. Comparative calibration for weights
19. = 21. 10 fl Micrometer compass (drawing tool)
22. = 20. 18 fl Brass faucet for water turbine
21. 86 fl Journey to Vienna and back
22. 2 fl Bookcase and tools
23. 40 fl brass stand with all the necessary equipment
13 = 25. 8 fl 40 kr Prussian measuring devices (perhaps in conjunction with the Berlin Academy)

From 8 April 1769 to January 1785, Gabrijel Gruber was head of the Department of Drawing, Geometry, Mechanics (Engineering, Low Construction, Mapping and Special Naval Shipbuilding) and hydraulics. After Gruber's

¹⁸⁰¹ Bufon, 1971 Naravoslovje, p. 52; Wilde, 1860 Haupttabelle, pp. 68.

¹⁸⁰² Kovačič, 1998 Rektorji, p. 66; Schmidt, 1963 Zgodovina, pp. 135, 164.

¹⁸⁰³ Schmidt, 1963 Zgodovina, pp. 164.

departure from Ljubljana in January 1785, Gruber's pupil Jožef Marija Šemerl acted as the head of his Chair of Drawing, Geometry, Mechanics and Hydraulics. The lectures had to cease after the emperor suspended his financial support of Carniolan Society for Agriculture and Useful Arts (Agricultural Society) in 1787.¹⁸⁰⁴ The Sunday German language lectures at the craft school were conducted by Gruber himself, and after his departure the school was taken over by Šemerl. Gruber also offered awards for the most talented

Table 15-5: Costs for instruction which Gruber proposed in the summer or autumn in 1768:
 »Inventory or determination of the use of books, devices, machines and models for conducting business from the highest point of the established Mechanical School at the Agricultural Society, composed by the professor Gabrijel Gruber on 31 August 1768« (AS 33, Provincial government, convolute 455, technical unit 182) and again in the pamphlet on 28. 9. 1768: "Expenditure for Mechanical School Equipment" (AS 33, Provincial Government, Convolute 455, Technical Unit 182). The numbered ones in August are presented as bold, and the editions of the September are in italics, when instead of the original twenty-five expenditures for the total amount of 409 florins 33 kreuzers, Gruber proposed only twenty-three supplies for a total of 9 florins less, therefore, only 400 florins 33 kreuzers. We show only devices that were also useful for vacuum experiments.

15. = 17. 28 florins (fl) 30 kreuzers (kr) Precise scales for experiments
16. = 18 8 florins (fl) 30 kreuzers (kr) Scales from lead
17. = 19 8 fl 30 kr High precision scales for measuring pounds weights
18. = 20. Comparative calibration for weights
19. = 21. 10 fl Micrometer compass (drawing tool)
22. = 20. 18 fl Brass faucet for water turbine
<i>21.</i> 86 fl Journey to Vienna and back
<i>22.</i> 2 fl Bookcase and tools
<i>23.</i> 40 fl brass stand with all the necessary equipment
<i>13</i> = 25. 8 fl 40 kr Prussian measuring devices (perhaps in conjunction with the Berlin Academy)

students with the Carniolan Agricultural and Useful Arts Society's money. In 1787 the school was abolished because of the lack of state support inside the centralised milieu of Josephine reforms.

In addition to the Department of Mechanics and Hydraulics on the Lyceum, Gruber continued his teachings at the craft school after 1773. It seems that Erberg and Gruber sought to modernize their devices to acquire new scales, which was in the spirit of Lavoisier's progress in chemistry and vacuum techniques. Since 1755, three scales have been used on the Ljubljana College, among them s'Gravesande's and hydrostatic. Precise weighing in the Lavoisier's Parisian Laboratory made it possible to advance the technique in the coming decades.

The brass pipe for the water turbine was the ancestor of the device of the same name, which Georg von Reichenbach assembled in Augsburg in 1821. In 1770 Gruber certainly needed it also for his restoration of a hydraulic machine for lifting water from the Sava River to the water supply for the city of Kranj north of Ljubljana.¹⁸⁰⁵ The micrometer core for astronomical observations was catalogued on March 28th, 1779. It was a precision micrometer needed for astronomical of measurements whose acquisition was planned in connection with the previously printed examinations of John Baptist Pogrietschnig's students Franc Ksaver Karpe and Franz Svetic, bind to Asclepi's paper on micrometer objective lenses in Ljubljana in 1768. Gruber used that modern device for astronomical observations needed for navigation.

15.6.3 *Ambshell's Devices in 1779 and 1785*

It is difficult to estimate how much the fire affected the former Jesuit vacuum and other devices physical and mathematical curricula in Ljubljana in the summer of 1774. Only relatively comprehensive censuses from 1755, 1779 and 1785 are available with some intermediate footnotes and one inventory of purchases for each year between March 1781 and March 1, 1782. While Anton Ambshell (* 1751, Győr; † 1821, Bratislava) on 28 January 1779 and on 7

¹⁸⁰⁴ Serše, 2000 *Začetki obrtnega šolstva*, pp. 42.

¹⁸⁰⁵ Žontar, 1982 *Zgodovina mesta Kranja*, p. 206, 238, 278, 297, 454, 458.

November 1785 made brief descriptions of the seventy or sixty-six devices with notes on their utility. However, on 22 July 1779, for now unknown reasons he only noted the first

Table 15-6: Three preserved catalogs, marked italics (oblique), bold and normal.

<p>First list of 28. 1. 1799 (<i>seventy devices</i>): "Inspection or inventory of personally audited available physical machines and devices with notes on their condition in Ljubljana on 28. 1. (1779)« with Ambschell's signature (ARS, AS 7, Regional Governance for Carniola, Rubrica Publico Politica, Litera S, Numero 19, volume 6, box 72, Acta de ann. 1778)</p>
<p>Second catalog of 22. 7. 1779 (thirty-five devices), of which just before the 18th device the record of their industry was noted as Hydrostatic: "22. July 1779, the listed physical equipment in use, as well as examples of the necessary machines, etc." (ARS, AS 7, Regional Governance for Carniola, Rubrica Publico Politica, Litera S, Numero 19, volume 6, box 72, Acta de ann. 1778)</p>
<p>Third list provided on 7. 11. 1785 (106 devices: 26 statics and mechanics + 19 hydrostatics-hydrodynamics + 8 gases + 7 heat + 21 optics + 13 electrics + 2 astronomy + 10 miscellaneous). It contained once Jesuitical and later acquired physical devices in the list produced on the handover of the recently dismissed Ljubljana Professor Ambschell and the representative of the Ljubljana Kreisamt (mayor's office) Galle, with the mark of the usability of devices. It is preserved in four copies, written by different hands: "The inventory of physical machines found at the physical (cabinet) in Ljubljana on 7. 11. 1785", AS 533, KKD (= Carniolan agricultural society) / Copies, Statute / 1780-1820, unpagged). Figures before the devices were taken from the appropriate census. The numbering in both censuses in 1779 is continuous, and in 1785 there was a separate numbering for each of eight branches of physics. The same devices are separated by semicolons for different censuses. Only the instruments associated with the vacuum techniques of those days are shown.</p>

35 tools for statics, mechanics, hydrodynamics devices and aerodynamics with a vacuum technique listed on eight pages. The end of the census of July 22, 1779 did not closely follow the

division into physics chapters. Any continuation of the missing descriptions of devices to show experiments related to optics, electricity, heat, astronomy and diversity has not been maintained; the supposedly lost part of the document certainly included the certificate of the responsible person, so that without complete evidence, the missing signature could be attributed to professor Ambschell only with a high probability. Therefore, the lists of individual devices and their operation of 22 July 1779 are much more extensive and detailed than other preserved material.

15.6.3.1 Devices for the Display of Static and Mechanical Phenomena

3: **Scales with weights of 10, 5, 4, 3, 2 1, ½ and ¼ pounds** (in modern measures from 5 kg to 140 g), five items for each weight; 2: lead and brass weights: 4 weights of 5 pounds, 4 pounds, 3 pounds and 2 pounds. Six weights for a pound and two pounds. Ten weights per quarter of pound and two weights per eighth part of pound.

1: *Libra with two large and small bowls, medium well received, good.* November 7, 1785: 3: Another large scale with two large and two small attachments, bad.

4. **Weight for 1 pound in the form of a truncated cone**; 4: Single pound insert, broken

5. **Small weights for the ounce (28.35 g), half ounce, gran (0.82 g) and their parts required in hydrostatics and in air-related experiments**

5: Small balance with bell and 5 lead weights, conditionally useful

2: **Sensitive balance for experiments.** 6: ... with a brass attachment and a wooden scraper, good

8. **Simple movable and stationary wheels with clamps for propelling multiple saw blades and other devices**

13. Linked axles for the stampers in a mill

4.2 Hydrostatic and hydraulics experimental tools

1 Fountain with one water supply, two pipes, a large brass pipe and a large collector of 4 feet, good

2: To the above belong 3 hermetically sealed tubes of 5 ft long, good

3: To that (fountain) belong 4 utensils, namely: carousel, lamp, tail and snow meter, good

7: *lead model for fountain, new, good*; 4: lead model for fountain

5: The same cylinder connected to the cone along the common base, good

8: *Heron's fountain, usable, repaired*; 6: Hermes' (sic!) Fountain, good

9: *(Kircher's) flowing fountain, picked up, broken*;

7: good

10: Another well, broken; 8: Reverse siphon, good

11: *Connected vessels, assembled, broken*; 9: good

13: *Two lead (vessels), assume, good*; 18: **Two glass cylinders fitted with movable closures, one with metal**; 10: Two lead water heater, good

12: *Glass bowl or water receiver, new, good*

14: *Two sealed tubes with wooden attachment on one side, picked up, good*

15: *Four siphons, new, good*; 11: Two siphons, good

16: *Six glass tubes, new, good*; 12: 6 glass tubes, good

17: *long glass tube, taken over, good*; 13: good

18: *Lead cylinder, inserted into another, lead, picked up, good*

14: Brass cylinder in the cylinder also made of brass, by the pan, good

20. Copper water troughs, two of them smaller, on one side with soldered copper conductors along one inch, and the end is approximately 2 to 3 inches at right angles along the circle. The height of the waterbed must be 14 feet. There is a good faucet or cock on the pipe, where the water flows through the open pipe. The pipes include special threads, one larger and the other smaller, in total, there are three or four. One (attachment) is sheet metal with a brass screw under the visible tube with a length of 4 feet and a width of 1 inch, the other is 2 feet long and one inch wide; while the copper (tube) flows into the experimental space where, under the lamp, the water is separated into the constituents (probably its mineral contents, sic!) to collect a lot of such snow (resembling the snow in Hell's pump in Banská Štiavnica).

18: The metallic sheet 5 feet long and 3 feet wide device for twisting waterworks, good

19: Glowing round bell made of brass, good

4.3 Apparatus for displaying air experiments

53: *Vacuum pump that was repaired, but without a large box which does not have its own valves, picked up, but not good*; 21. **An upright vacuum pump of alternating (Hauksbee's) double-barrelled design. Among the recipients one is small and the other is large, one with a large cock (pipe), under which we can place a barometer;** 34. **An elongated glass hose (actuator) 4 inches wide and 3 or more feet long, closed with a brass hood. This lid has a suitable**

pliers in the middle, which can be opened from the outside without moving the board for gravity experiments in a vacuum;

35. A horizontal still unused vacuum pump, which is like Boyle's vacuum pump under the number 21.

1: (Hauksbee's) double-barrelled vacuum pump, good

22. Glass ball with a large brass cock, which must be firmly attached so that the cock can be screwed onto Boyle's vacuum pump and could exhaust the air through the valve.

23. A similar copper (ball) with a faucet designed to hold 2 or 3 polished balls.

24. Parabolic wooden arch one foot long with the thickness of 3 inches. The inner surface of the bow, which should be half or three quarter of inch wide and 3 inches long. On one side, a cone is attached which, on one side, pours out of wood, so that the sunken arc forms a cone, which appears in the mirror as the focal point of the parabolic mirror; the bow is attached to Cheredon or a tripod.

25. Cheredon or a tripod, with which the fixed arch is raised or lowered

26. Tripod for the observations from all directions, which has an exact base

27. Precise Micrometer

54: *Two Magdeburg hemispheres, good*; 2: Two large Magdeburg hemispheres, good

55: *Gas-meter (Parometer), new, good*; 3: Gas-meter without glass, good

4: Six recipients, three opened at their tops and three closed

5: Another three recipients, the first with a brass tab, the other with a long open wood and a brass tab, a third without a closed brass, are connected altogether with the afore mentioned stand

30. Glass tube, open on both sides with a diameter 3 inches, one and a half foot long; on both sides there must be two caps of brass in the glass. Each one has a brass orifice, at least 3 cubic feet long, in addition to the sharpness that is screwed onto Boyle's vacuum pump.

6: A spherical ball with a brass pipe, good

7: Copper ball

8: Two small Magdeburg hemispheres

4.4 Devices for displaying experiments with fire

56: **Désaguliers pyrometer, new, good**; 1: **Désaguliers' fire gauge with the 4 inches long metallic sheet and filter for water, good**

57: *Two thermometers, new, good*; 2: *Two thermometers, one in brass, the other in a wooden box, good*

15.6.3.2 Devices for Experiments with Light

32. **A glass didactic game with figures of 8 or 9 inches and a smaller length.** Here Ambschell added a note for maintenance: When purchasing machines, they are cleaned with a cloth in preparation for their first use, and we regularly monitor it carefully to ensure that the durability of used machines is best dealt with. (During holidays), we store them at least until the end of October, so that machines can reduce costs and increase durability.

15.6.3.3 Electricity Display Devices

26: *Other (negatively charged) electrostatic spindle from cardboard with leaden conductors, good*; 2: *Other (negatively charged) electrostatic spindle with leaden conductors*

27: *Old spherical electrostatic generator with conductors made of brass, picked, broken*; 3: *Old circular electrostatic generator*

28: *Large and small amplifier with conductors made of brass, polished, broken*; 4: *Large amplifier made of brass*

5: *Three other amplifiers with screws, good*

29: *Electrophorus on lead base, new, good*; 6: *Electrophorus, good*

30: *Other amplifier, new, good*; 7: *Screw amplifier, good*

31: *Two brass and one iron circuit, new, good*; 8: *good*

32: *Electricity translation tube, new, good*; 9: *good*

33: *Four bells without their clappers (for ringing under electric current), picked up, good*; 10: *good*

34: *Rubbing brush (friction in an electrostatic machine), new, good*; 11: *good*

15.6.3.4 The Author of Inventory and his Devices

On April 28, 1779, only Ambschell was signed under the record of physical devices: "In Ljubljana on January 28, Anton Ambschell, a physics teacher, I certify that all the machines listed are found in the condition together with the things found on the spot." The second part of the inventory with a possible signature of July 22, 1779 was not found. Under all the lists dated 7/11/1785, both former physics physicist Anton

Ambschell and Karl Baron Gall, on behalf of the Kresia Office of Ljubljana, were signed under the transshipment inventory in Ljubljana. Only until October 20, 1785, Ambschell was a professor of physics and rector in Ljubljana, and then two years later he was a professor of physics and mechanics in Vienna, after Bishop Herberstein offered him a lecture in Ljubljana on 1 July 1783 after a ban on preaching for complaints students due to too many domestic (familiar) procedures in physics examinations according to Biwald's textbooks.¹⁸⁰⁶ The next document in the same package dealt with the books of the libraries.

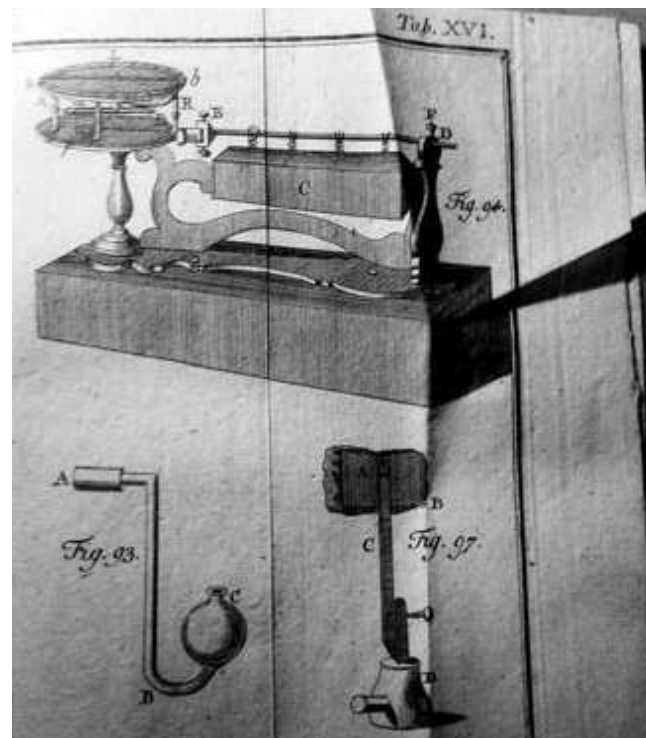

Figure 15-35: Figure 93 with the Drebbel thermometer and Figure 94 with the measurement of the expansion of heated bodies on table 16, described on pages 164 and 171, drawn at the end of the second part of Ambschell's favorite experimental manual Sigaud de la Fonda, published in 1785 (photographed by a writer in Franciscan Library in Ljubljana with the permission of Dr. Miran Špelič OFM).

Of course, the most attractive vacuum pumps were among the devices for gassing. But not just that. Prior to 1779, the residents of Ljubljana were also able to afford the gasometer (Parometer), which in

¹⁸⁰⁶ SI_AS 7, Deželno Glavarstvo, Ecclesiastica, box 212, Litera A, Numero 8, Volum 1, Ambschell Priesters Beschuldigung / wegen Verschiedener In-Briefen. Acta de annis 1782, 1783.

Table 15-7: Physical (and above all chemistry) experiments with their costs noted in the Ljubljana higher schools between March 1781 and March 1, 1782 (ARS, AS 7, Regional Governance for Carniola, Rubrica Publico Politica, Litera S, Numero 19, Volume 9, Box 73).¹⁸⁰⁷ Only the devices associated with vacuum techniques are listed.

Inventory number	Price	Name of the tool
5.	1 fl 48 kr	2 pounds of yellow wax of 54 kr each
6.	27 kr	Chalk
7.	36 kr	4 pounds of rosin (residue from the distillation of turpentine oil useful for the chemical industry)
8.	5 fl 30 kr	2 ½ pounds of silver per 2 fl 12 kr each
9.	1 fl 9 kr	Smoky HNO ₃
10.	48 kr	8 lots of staniol (Tin Foil) per 6 kr each
11.	42 kr	7 lot of turpentine oil
12.	5 fl 40 kr	the second tripod-stative for the mirror glass plate of the electrostatic generator, which was unnecessarily missing in the friction electric collection
13.	4 fl 30 kr	4 ½ measures of wine spirits (ethanol obtained at the distillation of wine sold in a 5-percent to 70-percent solution in the Newtonian period). 1 florins for everyone

1785 was renamed it into the air gauge. Certainly, it was an Ingenhousz or Volta's improvement of the eudiometer for the measurement of the "goodness" of the air according to the invention of Marsilio Landriani (1751; † 1815) in 1775. The freemason and imperial physician Jan Ingenhousz (* 1730; † 1799) was fine. In 1769 and 1789, he corresponded with B. Hacquet, who used the Ingenhousz's Eudiometer (euriometer) with sodium nitrite to investigate the cause of auto-burning in high mountains; Hacquet borrowed his school tool, but in the meantime, he also wrote to

¹⁸⁰⁷ ARS, SI_AS 7, Deželno glavarstvo za Kranjsko, Rubrica Publico Politica, Litera S, Numero 19, volume 9, box 73.

Idrija pharmacist E. Freyer, although they were not always in their best relations.¹⁸⁰⁸ The eudiometer has become particularly popular in Volta's electric gun pistol design; two eudiometers for chemical syntheses and one electric gun were also used by Janez Krstnik Kersnik (* 1783; † 1850) in 1811.¹⁸⁰⁹

Among the experiments with heat, a pyrometer was compiled in the first place. The English freemason and the editor of the London Royal Society journal Phil. Trans. Désaguliers invented that tool to observe the shrinkage and expansion of metals in temperature changes. Nowadays, a little later invention of the modern pyrometer is attributed to the queen's potter Josiah Wedgwood (* 1730; † 1795). The associate of Birmingham's Lunar Society Wedgwood was accepted as a fellow of the Royal Society right after the publication of his discussion on the pyrometer for temperature testing in pottery baking in the once-day Désaguliers' Philosophical Transactions magazine in 1783.

15.6.3.5 Annual Purchases in 1781/82

An annual grant of the cabinet of physics was 25 florins (fl) under Jesuit guidance between 1763 and 1774. It covered 5 % of the price of the original fifty-four Erberg's orders. Thus, between 25 March 1781 and March 1, 1782, 17 of these chemicals were purchased for 17 consecutive months, with 26 fl 28 kreuzers (kr). The title of the document written on March 1, 1782 was: "A list of the usual annual expenditures of the *Estates General Superior of the State*, given for physical experiments, when this year reached 25 fl and was spent between March 1781 and March 1, 1782". 56 kr was a deficit over the previous year exceeding the 25 fl supplements used under the first item; followed by a list of new acquisitions to point 18. Among other things, they bought six times eight lots of staniol (Tin Foil) for a total of 88 kr under number 10 (the Viennese loth (lot) measured 4 quintiles or 17.5 grams, 0.56 kg = Viennese pound = 32 lots) and under number 9, the spiritum

¹⁸⁰⁸ J. Pfeifer, 1989 *Zgodovina idrijskega zdravstva*, Idrija, 73.

¹⁸⁰⁹ ZAL, LJU 184, The classical grammar school in Ljubljana, the technical unit 53, the 14th device on pages 8 and 10 respectively, among the devices for heat and electricity (Eudiometer) and the first device on non-aggregated pages 9 and 18 among electrical devices (Pistolletes (sic!) electricques).

nitrians, most likely HNO₃, for 1 fl 8 kr. The most expensive then purchased device for the price of 5 fl 40 kr were the devices for the operation of the electrostatic generator, recorded under number 12, as the only outstanding physical device among the prevailing chemicals. Anton Ambschell, who signed the document on 1 March 1782 in Ljubljana, was also a member of the Viennese University. The total cost of purchases in the amount of 26 guldens 28 kreuzer was confirmed by chamber bookkeeping two and a half weeks later, on March 12, 1782.

15.6.3.6 Destinies of First Physics Experimental School Devices of Ljubljana in Nineteenth Century

The professor of physic Ambschell certainly had the first the word in the purchase of new devices in 1779. It is therefore not surprising that he has thought of many vacuum devices, with which he experimented and published his findings.

In 1811, Kersnik attributed slightly different names to his experimental tools in Ljubljana also because he used French language. The most popular device in Ljubljana was an electrophorus found in the censuses from the years 1779, 1785, and 1811.¹⁸¹⁰ During the first experiments with the ancestor of the electrophorus, Augustin Hallerstein of Ljubljana took part in experimenting in Beijing in the 1750s. On 1775 in Como Volta based his research of Beijing data before his assignment to the University of Pavia. He assembled the electrophorus. In 1833, the professor of mathematics in Slovenia, Karl Hummel, published a paper about a simple electrophorus for collecting electric charges with friction¹⁸¹¹ in Baumgartner and Ettingshausen's Viennese magazine; this was the first journal of mathematical science in the monarchy.

In 1833, a chemistry chair for Kersnik was founded at the Surgical-medical department of Lyceum, where Mihael Peternel (* 1808, the Laniše farm in the then parish of Nova Oselica (Neuosnitz); † 1884) later assisted him. Peternel was appointed as the teacher in 1842.¹⁸¹² In 1845

Peternel was Kersnik's chemistry assistant,¹⁸¹³ but he also lectured on the Lyceum on the same subjects of chemistry; there, of course, he carefully examined the vacuum and other physical aids and records of them, and added his, still interesting notes. Between 1853 and 1861, Peternel lectured on chemistry at the lower level Real High school in Ljubljana.

The nationally aware Slovenian Peternel was a longtime professor of chemistry, natural sciences, Slovene language and physics until 1860/61. In 1850 he was also the director of the real school in Ljubljana.

In his Agricultural Chemistry published in Slovenian language, Vertovec used simple words; with them he tried to inform the ignorant reader of the mystery of chemistry, which "educated students learn for many years". From these terms and from those presented by professor Mihael Peternel in the discussion: "Names, designations and properties of chemical elements" in the reports of the Ljubljana Real school in 1862, the Slovene chemical terminology developed. Peternel investigated the impact of electrical discharges on weather conditions under the influence of lower pressures.¹⁸¹⁴ Robida added his own terminology in his physics in 1849.

15.6.3.7 Conclusion

In course of the two and a half-century, the Ljubljana physics-mathematical cabinet, with the emphasis on modern vacuum techniques, of course got its updated among the next generations. Due to the lack of technical heritage preservation works, today's vacuum devices are difficult to find, since they were often discarded, as we still do with old bad toasters or with old washing machines. Everything that profoundly tells us about these tangible pillars of learning of the former Ljubljana-based science-oriented youth has been preserved just in some catalogs, which at least partially unravel the patina of the former days. One thing is certain: Ljubljana students, unfortunately only male, have been able to view the basic knowledge of the novelties of vacuum techniques and related sciences in the high school at home without any real delays regarding the then centers of science,

¹⁸¹⁰ ZAL, LJU 184, The classical grammar school in Ljubljana, technical unit 53, 32nd tool on pages 8 and 14 among electric devices (Electrophore).

¹⁸¹¹ Hummel, 1833 Erscheinungen, pp. 213–235.

¹⁸¹² Dassenbacher, 1868-1869 *Schematismus*.

¹⁸¹³ Nučič, 1964 Kemija.

¹⁸¹⁴ Dežman, 1858 Report on session of January 2, 1856, p. 88.

although they may not have been taught by the giant vacuumists of Boyle or Pascal's class.

15.7 Volta's Relative and His Idrija Pharmacy: Idrija Mercury for Barometers and Thermometers (on the 275th Anniversary of Volta's Birth)

15.7.1 Introduction

Of course, the Ljubljana vacuum devices were not the only ones in the country. For centuries Idrija was the cradle of technical achievements in Carniola. The Viennese authorities sent the most prominent experts to Idrija. They wished to improve the processes of obtaining and processing Idrija mercury ore. The most prominent leaders of the Idrija mine were Abondio Inzaghi and his great grandson; the latter primarily because of his close relationship with Alessandro Volta.

15.7.2 Abondio Inzaghi and Torricelli

Abundus Maria Inzaghi (Abondio, Abbondio, * Como; † 1691, Graz) was the Councilor of the court chamber and the senior mining supervisor in Idrija under the emperors Ferdinand III and Leopold I and their first minister the prince-vacuumist Janez Vajkard Auersperg. Like the Ptuj based brothers Caccia, he initially dealt with the sale of cloth and moneymaking; Later he moved to Graz, where he became head of the monetary office. He reorganized the production of mercury in Idrija and then controlled the trade of mercury, copper and similar goods.¹⁸¹⁵

Abondio was established in Carniola in parallel with the relative of Galileo Galilei, Roberto Galilei (* 1615, Florence; † 1681, Ljubljana) in the shadow of the mighty Auersperg. While Abondio settled in Graz and Idrija, Roberto led his banking and political affairs from a rented house near the Šuštar (Carpenter) Bridge in Ljubljana, at least after the birth of his oldest son, Bartolome Engelbert Galilei, baptized in the Ljubljana Cathedral on February 11, 1648. According to Robert's perhaps slightly altered claims, Roberto

Galilei should have been working in Carniola as early as 1632. At the beginning of Abondio's and Roberto's work in Carniola, the scientific successor of G. Galileo, Evangelista Torricelli (* 1608; † 1647), set up the first vacuum experiment including the Viviani's initiative with Idrija mercury thermometer in 1643. At the end of 1644, he informed about his success the Parisian monk Marin Mersenne, who was the main distributor of scientific ideas in the then Europe; Mersenne soon became acquainted with Blaise Pascal's novelties. In 1646 Pascal publicly repeated the experiment, and in 1668 he sent his brother-on-law into the hills with a huge mercury barometer, full of Idrija ore. With this, the mercury barometer also became a tool for determining heights. Ten years after Torricelli's beginnings, Otto Guericke developed experiments with a vacuum pump at the initiative of Prince Janez Vajkard Turjaški (Auersperg) in 1654. Using a mercury barometer, Guericke, as mayor of the city of Magdeburg, successfully predicted the upcoming storm, and earned the electoral votes of his fellow citizens and, above all, the sympathies of Magdeburg housewives even if they were not allowed to vote directly.

The imperial deputy for Financial and Military Issues Karl Gottfried, Count Breuner (Brenner), appointed Abondio as the chief inspector of the Idrija mine. With the acquisitions of the manors north of Graz, Abondio joined the Styrian Estates general on 19 August 1658. Abondio Inzaghi introduced the state management and sale of Idrija ore in 1659. He accelerated the export of Idrija mercury through the Amsterdam firm of Johann Deutz (Jean, * 29. 11. 1618; † 1673), a German native of the city of Cologne. The Emperor Leopold raised Abondio into the rank of baron and then into the rank of the count. However, the luck sunk down and soon it began to rummage that Abondio has more profit from the sale of mercury than the state treasury itself.¹⁸¹⁶ On 12 December 1667, he was suspended after a scandalous two-year process, like the modern processes in Slovenia. On 3 December 1669, Abondio was finally discharged from the Idrija mine. Even Abondio's nephew Benedetto Odescalchi (* 1611) was unable to help. In 1674 Benedetto Odescalchi (* 1611 (Como) put the foundation stone of the church next to Abondio's Castle Oberkindberg; he was assisted by Benedetto, although Benedetto two years later became Pope Innocent XI The

¹⁸¹⁵ F.Gestrin, 1981 *Italiani v slovenskih deželah od 13. Do (up to) 17. stoletja, Zgodovinski časopis*. 1981, 35/3, 234.

¹⁸¹⁶ Leskovec, Stančič, 2013, 193 229, 236–237.

investigation against Abondio was led by Wenzel Franc Lobkowitz (Wencel Evzebius, * 20. 1 1609, Prague; † 22 April 1677, Ravnitz (Roudnitz, Rudnice) near Laba in the district of Letimeritz / Litomerice) who became the mayordomo in 1664. Lobkowitz simultaneously displaced from the Viennese court the first important Carniolan vacuum researcher, Janez Vajkard, Prince of Auersperg. As Auersperg bought a lot of manors near Idrija and had a lot of diplomatic friends in Amsterdam, he knew Abondio very well and their downfalls were certainly related. That was a time of great friction at the Zrinski-Frankopan's conspiracy, which ended with the decapitations of Croatian and Hungarian nobles in the spring of 1671.

use of mercury was quantitatively small in barometers compared to the needs for amalgams for the cleaning of silver ore, it was scientifically prestigious to use mercury. As always, an exceptional prestige brings glory and sales. Scientific use of mercury, of course, did not begin with vacuum barometers, because the mercury was all the time a fundamental element of alchemical

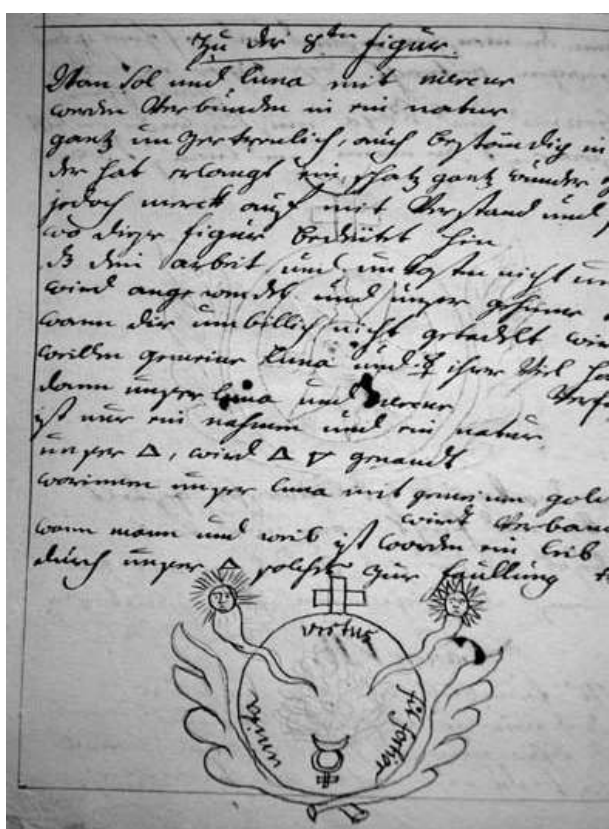

Figure 15-36: Freyer's doubled Sun shining on the fountain spring in Freyer's abundantly illustrated student copy of the book JC Vanderbeeg Das geheime Buch der Weisheit Zur Langen Leben und Vollkommenen Reichtum (1739) (SI_AS 863, p.1)

The only real rival of Idrija mercury was the Spanish mine Almadén, where in 1645 the state also withdrew powers from the powerful bankers Fugger so that the state could take over the administration itself. Early enthusiasm for mercury vacuum barometers greatly contributed to the increased demand for Idrija mercury; although the

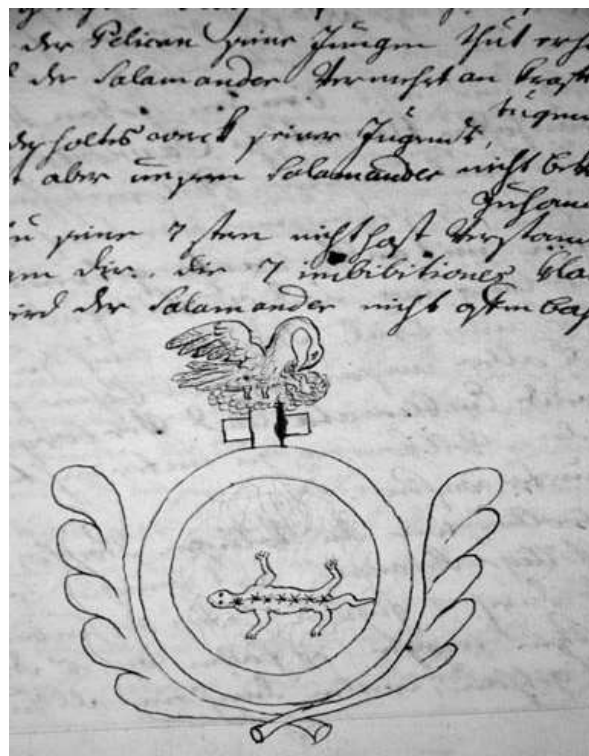

Figure 15-37: Swan above the salamander in Freyer's abundantly illustrated student the copy of JC Vanderbeeg's book Das geheime Buch der Weisheit zur Langen Leben und Vollkommenen Reichtum (1739) (SI_AS 863, p. 1)

transmutations, which were also taken by crowned heads from Emperor Rudolf II (* 1552; † 1612) all the way to Leopold I. The alchemists used vacuum techniques to distill their secrets mostly with fractional vacuum distillation, probably found by the Greek alchemist Padanius Discorides (* about 40; † 90). He was the military surgeon of the strange emperor Nero; he noticed a condensed substance on a lid of a vessel in which he heated mercury in Rome. The fractionation distillation techniques at reduced pressures were then developed by others in pharmacists' alchemy. In Idrija, basically the founder of the pharmacy was a Bohemian chemist Ernest Freyer, the beginner of the most important dynasty of Slovene pharmacists, with his son Karl and his grandson Henrik Feyer.

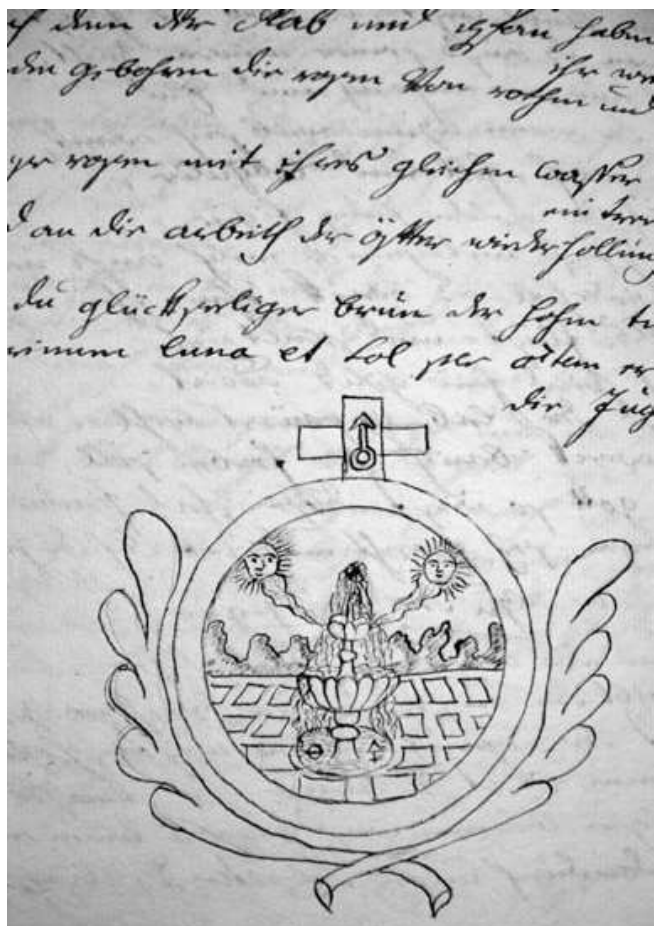

Figure 15-38: Freyer's Sun, sown on the fountain spring in Freyer's abundantly illustrated student copy of the book JC Vanderbeeg *Das geheime Buch der Weisheit Zur Langen Leben und Vollkommenen Reichthum* (1739) (SI_AS 863, p.1)

Freyer learned vacuum distillations at home at Žatec, the base of the producing of good beer. Between 1751 and 1753, he learned pharmacy skills in the Ljubljana pharmacy of Franz Karl von Weinhardt (Weikhard, Weykhard, * 1703; † 12. 6. 1768, Ljubljana) on Novi trg no. 2 (today Jurčič Square No. 2) who bought the house in 1740. Weinhardt supplied Idrija with vacuum-distilled medicines at Freyer's help during the epidemic of the pagan in 1752. Weinhardt was also successful in the business, since on 14 February 1754, he sued in Ljubljana even the famous sculptor Francesco Robba (* 1698; † 1757) for unpaid medication in the amount of 41 gulden and 33 kreuzers with 6% interest.¹⁸¹⁷ Franc Karl Weinhardt also had a house in Čevljarska Street no. 2. He led his pharmacy on today's Jurčič Square no. 2 until 1665, when his son from his marriage with Marija Klara, the doctor Karl Avguštin Weykard (* 24 August 1736,

¹⁸¹⁷ R. Andrejka, *Zgodovina kramarskih hišic v Prešernovi ulici*, *Kronika*, 1938, 5/1, 19.

Ljubljana) took over the pharmacy until 1785. Then until September 21, 1844, pharmacist Jožef Filip (Philipp) was the owner of the house.¹⁸¹⁸



Figure 15-39: The title page of JC Vanderbeeg's masterpiece from which Freyer copied and transcribed

Weinhardt's pharmacy had a centuries-old tradition and high-quality vacuum distillation equipment in Ljubljana for production of extracts of medicines. In the southern part of the pharmacy on today's Jurčič square no. 2 a pharmacist Valentin Cirian(i) and his wife Lukrecia worked between 1622 and 1629. From 1652/53 to 1661, the pharmacy was developed by pharmacist Ludovik Hauenstein (Hauenstain) together with his heirs until 1672; he was followed by the doctor of the Irish genus Janez Juri Tosch until 1694, and then by his descendants until 1705. Then the pharmacy was purchased by the pharmacist Janez Peter Sartori and his wife Ana Eleonora, who bought the neighboring northern house of Karl von Samburg (Sameburg) in 1717/18. Both buildings were merged into a single large pharmacy, if their successor Weinhardt did not do the job in 1752. The Northern House also had a pharmacy tradition, since it was operated by pharmacist Vincenc de Agnelatti from

¹⁸¹⁸ Fabjančič, 1940 *Ljubljanski Frankoviči v 16. in 17. stoletju (nadaljevanje)*. *Kronika*, 1940, 7/2, 142–150 and 206–214, here pp. 149, 213; Ludwig Schiviz von Schivizhoffen, *Der Adel in der Herzogthum Krain*. Graz, 1905, 76, 202.

17 March 1588 until 1618, followed by his heirs Janez, Jeronim, Vincenc and others until 1645.

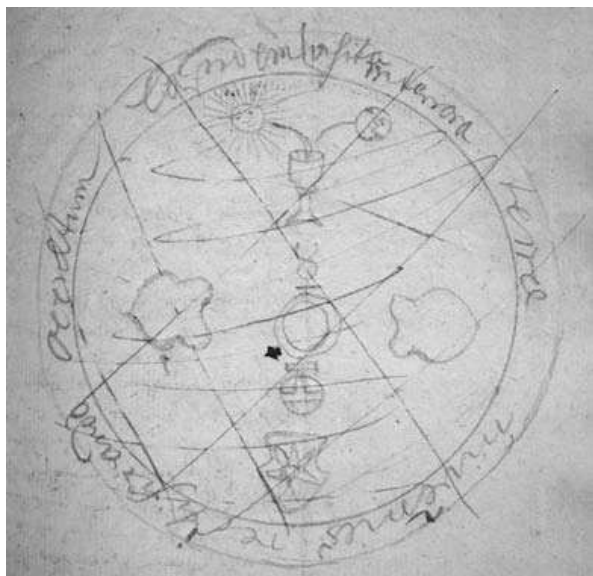

Figure 15-40: Freyer's symbolic sketch of distillation procedures in his manuscript book, dated 1751 in Ljubljana, entitled *Curiosity (Curiositatem cujus generis seu curiosa naturae miracula)* (SI_AS 863 Freyer's legacy box 1).

The pharmacist Janez Peter Sartori and his wife, Ana Eleonora, had several children in Ljubljana. On July 18, 1714, one of their godfathers was Adam von Pettenekh Pöttickh (* 1640/1645; † 1705). Adam von Pettenekh Pöttickh was a son of R. Galilei's Ljubljana host John Baptist Petek. Adam von Pettenekh Pöttickh served as the caretaker of the Military Krajina. On 26 June 1715, he chose his wife, Marija Ana Pettenekh born Wisethal.¹⁸¹⁹ Adam Pettenekh had a large library of works on medicine, pharmacy, and chemistry, also a silver compass¹⁸²⁰ which was an analog computer, created in the Galileo Galilei's workshop.

Franz Karl Weinhardt took his pharmacy from Ljubljana pharmacist Janez Peter Sartori, a relative of Inzaghi's predecessor on the head of the Idrija mine, Anton Sartori. Sartori took over the Idrija mine in 1754; because he urgently needed a pharmacist, his acquaintance Franz Karl Weinhardt recommended his student Ernest Freyer. With Freyer's arrival, the vacuum distillation procedures became the constant of the Idrija mine. When

¹⁸¹⁹ Ivan Vrhovec, *Zgodovina šentpeterske fare v Ljubljani*, 1903, p. 43; Schiviz, 1905, 43, 51, 55.

¹⁸²⁰ SI_AS 309, Pettenekh, 23. 1. 1705, fasc. 35, box 85, litera P, pp. 18–31, 100–104.

Anton Sartori died suddenly at the end of 1764, the new Idrija director, Inzaghi, of course inherited Sartori's pharmacist Freyer.



Figure 15-41: Freyer's transcript of Snyder's work, in which the description of a large mercury vacuum barometer was kept under the pen of Ernest's son and assistant Charles Freyer following the letter from the Lithopolitan Academy of Sciences (Swiss Stein am Rhein or Petersburg) mailed in 1787 (Johan Monte Snyder, *Universae Medicinae* (ed. Berlich), Götz, Frankfurt, Leipzig, 1678. Bind to Joannes de Monte Snyders (Snyder, about 1625-1670), *Metamorphosis planetarum: dass ist, Eine wunderbahrliche Veränderung der Planeten, and Metallische Gestalten in ihr erstes Wesen ...* (ed. Berlich), Tobias Oehrling, Frankfurt, 1684 (first edition 1663) (SI_AS 863, box 2))

When he took over the administration of the Idrija mine, Franc Janez Count Inzaghi (* 1734; † 1818) developed the perspectives of the use of Idrija mercury for scientific purposes. He was a second cousin of the mother of Alessandro Volta, who, after the ban of the Jesuits, taught in Como (1774) and then in Pavia (1778/79) along with Scopoli. Both cities were then in the same Habsburg state together with Carniola; sharing their same Habsburgian fatherland enabled the rapid acquisition of Volta's inventions in Ljubljana and Idrija and the hourly dispatch of Idrija mercury for barometers and other vacuum devices to the Volta's Laboratory. Volta's father had been a Jesuit for some time, and A. Volta also used the Jesuitical suits during his studies in Jesuitical school. Inzaghi also worked closely with the Jesuits of Ljubljana; he financially supported the publication of Škofja Loka native Martin Prenner's exam theses with the Jesuit professor of physics, Gregor Schöttl. The theses were based on Bošković's science of vacuum and atoms, which was also admired by

Volta. They were printed in 1769 in Ljubljana together with a book on the chemical background of the phosphorescence of the Torino professor of experimental physics with chemistry since 1747, Bošković's friend the Piarist Giambattista Beccaria.



Figure 15-42: A writer of these lines during his lecture on Bošković and Volta in formerly Volta's lecture room at the University of Pavia on September 10, 2011

Soon after his invention in the spring of 1777 Volta sent his last publications about the combustible air and his vacuum related invention of pistol and eudiometer to the emperor's brother, Prince Karl of Lorraine. Karl loved the electrical experiments as an enthusiastic Bošković friend. Karl's confessor in Brussels was A. Hallerstein's brother, the Jesuit of Carniola Janez Vajkard Hallerstein.¹⁸²¹ Of course, Karl and Count Kobenci in Brussels were arguing all the time, while the clever polite Bošković knew how to befriend both of those clever guys.

Volta's mother, Mary Maddalena, and the Idrija manager, Franc Janez Inzaghi, were the second cousins and despite the distances they maintained their close contact. Thus, at the end of August 1794 Volta invited Inzaghi in Graz to his wedding without knowing about the death of Franz Anton Inzaghi (* 1719; † 1791), the elder brother of the former Idrija administrator Franc Janez Inzaghi.

On January 10, 1794, Franc Janez Inzaghi congratulated Volta on his brunette bride from

¹⁸²¹ G. Pancaldi, *Volta: Science and Culture in the age of Enlightenment*, 2005, 29, 105, 152, 155; R. W. Home, *Volta's English Connection. Nuova Voltiana*, 2000, 1, 128–129.

Como, Maria Teresa Peregrini.¹⁸²² They married less than two weeks later so that Volta could forget his prolonged affair with the promising Parisian actress.



Figure 15-43: A writer of these lines during coffee-break with Italian scholars after a lecture on Bošković and Volta in front of the rectorate of the University of Pavia on September 9, 2011



Figure 15-44: Volta's pistol, stored today at the university in Pavia.

Franc Janez Inzaghi led the production of Idrija mercury at a time when Volta used mercury in barometers for his experiments with gases, especially in his "physical theater" of the Habsburg University in Pavia, where he joined two years previously employed Scopoli in 1779. Scopoli's and Inzaghi's associations with Idrija naturally smothered supply of mercury for pioneering scientists. In 1784, Volta visited Vienna, and the Habsburg authorities gave him an important amount of Idrija mercury for experiments in the "physical theater", which was roughly completed

¹⁸²² A. Volta, *Epistolario 1788-1800* (ed. F. Massardi), Bologna, 1952, 3, 224.

in 1788. In 1790 and 1791, Antonio Cetti (* 1752; † 1835) spent several weeks manufacturing Volta's thermometers, barometers and similar devices filled with Idrija mercury in Pavia. The priest Angelo Bellani (* 1776, Monza; † 1852, Milan) later added others.¹⁸²³

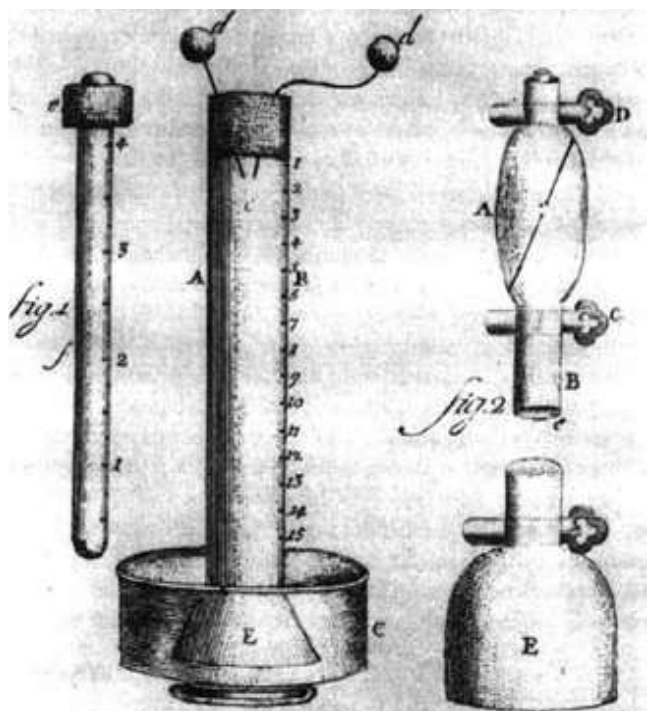

Figure 15-45: Volta's eudiometer, kept today at the University of Pavia

The members of family Inzaghi were highly educated; their technical talent was also inherited by Alessandro Volta (* 1745) by his mother Maria Maddalena Inzaghi, cousin of Idrija manager Franc Janez Nepomuk Inzaghi. In Graz Inzaghi gathered a well equipped library where they wrote their own ideas in their books. Among others, they had the first edition of Valvasor's *Glory and Topography, Experimenta nova* (1672) of O. Guericke in a joint binding with *Coelum Spheroticum Hebraeorum* of J. Chr. Steeba (1679), *China* of A. Kircher (1771 with Inzaghi's marginal notes and proprietary enrollment), Kircher's *Mundus Subterraneus* (Inzaghi had edition of 1678) and *Magnes sive de Arte Magnetica* (1654, with Inzaghi's bookplate).¹⁸²⁴ For Inzaghi's concept of vacuum,

¹⁸²³ Giuliano Bellodi & Paolo Brenni, The "Arms of the Physicist": Volta and Scientific Instruments, *Nuova Voltiana*, 2001, 3, 14–15, 21, 27.

¹⁸²⁴ *Rare and valuable books, incunabula, woodcutbooks, important library-works. Books on the fine arts comprising duplicates of the Imperial (National) Library, Vienna, the library of the counts Inzaghi, and other purchases recently added to our stock.* Vienna, 1923, 2, last 3 pages.

Otto von Guericke's book was of the utmost importance with its invention of the vacuum pump and the first meteorological forecasts using a barometer full of Idrija mercury. Similarly, Kircher's not deeply scientifically exact writing about chemistry of the underground and magnets was always interesting.

15.7.3 Idrija Pharmacist

Inzaghi's Idrija pharmacist Ernest Freyer (* 1729 Žatec (Saaz, Satz) near Ohr in the Sudetenland († 1795, Idrija No. 136) worked between 1754 and 1795. Johann Jacob Wecker and his namesake Johan Jakob Becher was among Freyer's most popular writers; Freyer got their semi-alchemical works like *De Secretis alchemiae Briefe*,¹⁸²⁵ *Physica Subterranea Opus Sine Pari* (Leipzig: Weidmann, 1738) and *Chemische Schriften*.¹⁸²⁶ E. Freyer manually copied the book (of Becher's Viennese colleague Wilhelm von Schröder (* 1640, Prešov in Slovakia; † 1688): *Nothwendiger Unterricht vom Goldmachen, denken Buccinatoribus oder so sich selbst nennenden foederativ hermeticis auf drei Epistel zur freundlichen Nachricht*. The book was published in 1684, and Freyer used a reprint from 1721 on public finances and alchemy titled: *Wilhelm Freyh. von Schrödern Fürstliche Schatz- und Rent-Cammer: nebst seinem Tractat vom Goldmachen wie auch vom Ministrissimo or Ober-Staats-Bedienten* (Leipzig: T. Fritsch). On 3 April 1661, 6 June 1661, and 9 June 1662, Schröder reported to Gaspar Schott from London on Boyle vacuum pumps and other devices. Schott¹⁸²⁷ as Kircher's pupil published the first printed description of the Guericke's Vacuum Pump. Freyer also transcribed *Conspectvs Chemiae Theoretico-Practicae: Tomus ... In Forma Tabvlarvm Repraesentatvs, In Qvibvs Physica, Praesertim Svbtterranea, Et Corporvm Natvralivm Principia, Habitvs Inter Se, Proprietates, Vires Et Vsvs, Itemqve Praecipva Chemiae Pharmaceuticals Et Mechanicae Fvndamenta E Dogmatibus Becheri Et Stahlil ... Explicantur ...* (Halae Magdeburg: Orphanotropheum, 1730). The work was compiled

¹⁸²⁵ SI_AS 863 box 3, *Beschreibung meiner im Besitz habende Bücher* 29. 4. 1790 (Freyer's books) 1790 1^v, unpagged no. 3 authored by Johann Jacob Wecker (*1528 Basel; † 1586).

¹⁸²⁶ SI_AS 863 box 19 Freyer's books, 25. 1. 1835, no. 55.

¹⁸²⁷ *Technica Curiosa*, 1664, 371–372.

by Johann Juncker (* 1679, Londorf; † 1759, Halle) with the help of Juncker's predecessor at the Department of Medicine in Halle, George Ernst Stahl (* 1660, Jena; † 1734, Berlin) based on the reflections of the Viennese alchemist and businessman Johann Joachim Becher (* 1635 Speyer, † 1682 London).

Freyer drew many alchemical symbols to illustrate the joining of elements; he was obviously interested in the eighteen decades old Viennese mercantilists and cameralists Schröder and Becher, and even more so in the modern Scandinavian crystallography and the pharmaceutical botanic edited by the Jesuits in Graz. Freyer continued to cultivate the alchemical traditions there in Carniola and Bohemia a century and half after the alchemistic Rudolf's court in Prague.

The association with Ljubljana's high society was necessary for 24-year-old E. Freyer to become the temporary leader of the pharmacy in Idrija following the order of Minister G. van Swieten, although on 20. 1. 1755 Janez Anton Scopoli (* 1723; † 1788) through the director Sartori asked the Viennese court to approve his preparation of medicines and the management of a pharmacy with an additional salary of 800 per year. On 20 September 1754, Sartori did not support Scopoli, as the doctors at that time were not supposed to supply their patients with medication because of the huge possible profits involved. C. Weinhardt offered Sartori the equipment and care of a pharmacy at a lower price of 400-500 per year. He also promised to provide an experienced person for the job of pharmacy manager. An unnamed specialist was, of course, Ernest Freyer, who allegedly joined the Carniolan experts of those days as a candidate for the apprenticeship (tironcinium) at Weinhardt's class Scopoli was not lucky enough to obtain a pharmacy on Freyer's behalf, but they continued to cooperate well; Scopoli, of course, tried to enforce Freyer and Hacquet's participation in some of Scopoli's own work, but they tried to avoid that funny honour one after the other. Of course, there was a great social difference between Scopoli and Freyer, and even greater between Scopoli and Inzaghi; their social ranks are well-documented by the notes on godparents for children, since Freyer was not involved in the noble baptisms or weddings. On the other hand, in 1783, Inzaghi's relative Volta described the eudiometer for Scopoli's extended

translation of the Dictionary of Chemistry of Pierre Joseph Macquer, which was surely a great honour for young Volta at that time.

Gregor Schöttl took over the department of physics-chemistry in Ljubljana on 22 October 1768, simultaneous with the arrival of G. Gruber to the College. The following year, Schöttl became a professor of moral theology, a professor of philosophy and confessor. Upon his arrival in Ljubljana, G. Schöttl donated to Jesuit library his books, which included his undated bookplate "In Soc. Bibl. Phil. Coll. Lab. S. J. Dono P. Greg. Schöttl". Among the donated works was a genealogical survey of the (princely) Counts of the Celje, connected with the examination theses, which were defended by the heritage-canon of Halberstadt and Hildesheim, baron Edmund Brabeck, a student of the second year of physics, mathematics and history under supervision of the professor of physics, numismatist Erasmus Frölich (Fröhlich) at Theresianum. Fröhlich was a member of the Societas incognitorum eruditorum and terris Austriacis, led by Joseph Leopold Baron Petrasch (Petraš, * 1714, Slavonski Brod; † 1772, Neuschloß in Moravia) in Olomouc from 1746 to 1751, together with Gerard van Swieten and professor of mathematics in Olomouc, Joseph Lewald.

In his special physics, Frölich described fire, phosphorescence, underground fire, thermometer, weight of the atmosphere, mercury vacuum barometer, similar siphon, hygroscopic, waterfalls, movement of the compass with reference to Bošković, steam, mist, rain, halo, rainbow, the electrical light and spreading of electricity.

He explained the causes of the heat of the sea and freezing, the types of earths or metals, the motion of a needle in a compass, and in this especially emphasized the opinion of then still young Bošković about magnets. This early mention of Bošković, as the only contemporary writer cited, ranks both Frölich and G. Schöttl among his early advocates. Frölich explained his electricity without any connections to magnetism. He described the attraction, reflection, light, and the spread of electricity.¹⁸²⁸

¹⁸²⁸ E. Frölich, *Genealogia Sounekiorum comitum Celeiae, et comitum de Heunburg specimina duo conscripta ab Erasmo Froelich, p. J. Mariae Theresiae Augustae dicata: cum sub Augustis eiusdem auspiciis Edmundus Lib. Baro a Brabeck*

G. Schöttl was the advocate of Newtonian science in Bošković's form, which was common-among the Jesuits of his time. He dealt with vacuum and pores in the bodies.¹⁸²⁹ He asked his students whether all the bodies were porous and wished to judge the size and shape of the pores. It was necessary to know the Cartesian, Epicurus, Gassendi, Newton and Leibniz's opinions on pores.

15.7.4 Conclusions

In the territory of today's Slovenia the Idrija mine manager Inzaghi among the first promoted Volta's vacuum novelties as the close relative of Alessandro Volta. He voluntarily supported the prints about Voltaic discoveries promoted by the Jesuits of Ljubljana. In Inzaghi's time, the Jesuits of Ljubljana quickly acquired Voltaic inventions, especially Volta's pistol (eudiometer). Collaboration took place in both directions, especially after Volta's takeover of the chair in Pavia, where the former Idrija physician Scopoli also taught. To renew the lessons at the Volta's Pavia, supported by Emperor Joseph II and the main Lombardian businessman-statesman after 1765, the Koper native Count Gian Rinaldo Carli (* 1720; † 1795), they required a relatively large amount of well-purified Idrija mercury for Volta's thermometers and barometers. Inzaghi's pharmacist Ernest Freyer designed many improvements in the production of Idrija mercury.

15.8 Vacuum Gauges by Tobias Gruber

15.8.1 Introduction

Among many Idrija visitors and explorers of mining vacuum devices, Tobias Gruber was especially distinguished, which we described our

Hildesiensis, et Halbertadensis Canonicus ex Philosophis, historicae & mathematicis disciplinis in Collegio Regio Theresiano p. J. publice respondens... Bind to: *Materia tentaminis publici : quod in Collegio regio Theresiano Societatis Jesu ex anni huius scholastici praelectionibus quovis, cui libuerit, periclitante subibit reverendissimus & illustrissimus D. Edmundus L. B. a Brabeck, ... mense Septembri ... MDCCLV. Viennae, 1755, 34–36, 37, 38 (NUK-262; NMLJ-4857/2).*

¹⁸²⁹ G. Schöttl, *Tentamen Philosophicum ex Logica, Metaphysica Algebra, Geometria, Trigonometria, Geodesia, Stereometrisa (sic!), Geometria Curvarum, Balistica et Physica, tam Generali, quam Particulari*, Ljubljana, 1775, thesis 13.

other works . Therefore, we prefer to focus on the inventions of T. Gruber's portable vacuum gauges; with them he became very famous, so they were still used on the scientific journeys for a good decade after his death. He could inventively adapt his inventions to the somewhat uncomfortable conditions challenging early explorers of the mountains.

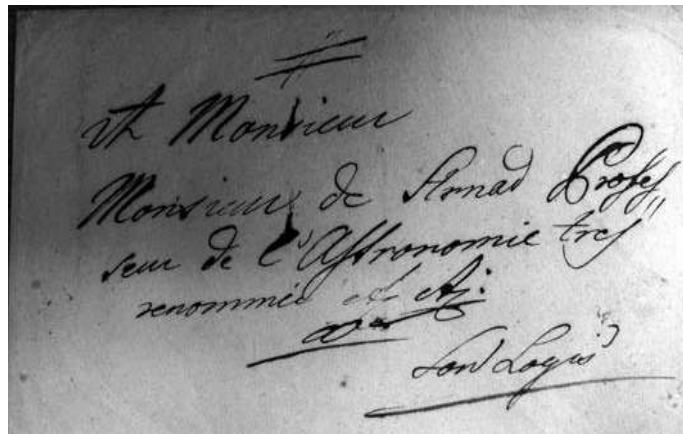

Figure 15-46: T. (Gruber's letter mailed to the Jesuitical astronomer Anton Strnad (Strnad, * 1746; † 1799) containing the autobiography of T. Gruber dated October 1804 (Archiv Akademie věd České republiky (Praha) / A. Fondy institucí / Fondy starších vědeckých společností, ústavů a spolků / Královská Česká Společnost Science (KČSN) 1766-1953, 79, inventory number 374)

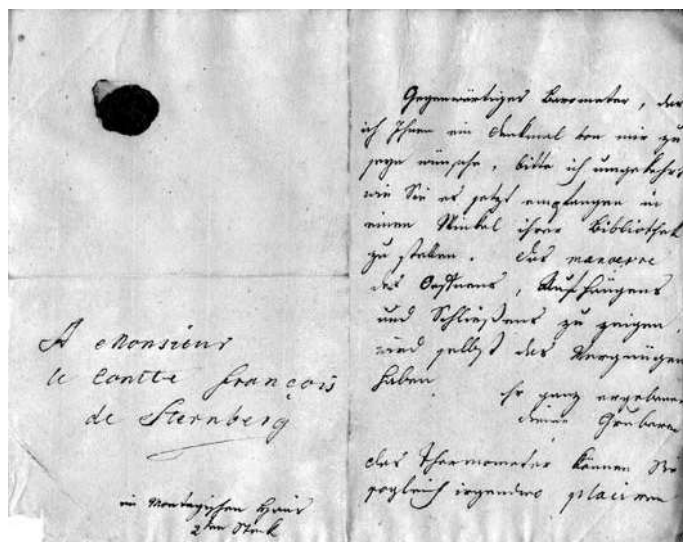

Figure 15-47: Tobias Gruber reports to his friend and patron Franc Sternberg about his designs of vacuum barometers and thermometers (Archiv Národního Muzea, Praha, Sternberk-Manderscheid Fund (ŠM) k64, undated).

Table 15-8: Volta's kinship with the leaders of the Idrija mine

generation	Name	Birth	Marriage	Death
1	Abundus Maria Inzaghi	about 1615, Como		3. 1. 1691, Graz
	+ Maria Magdalene Morelli von Schoenberg		marriage: 29. 9. 1644, Graz	17. 6. 1685
2	Johann Philipp Inzaghi	about 1645		1. 3. 1729, Graz
	+ Anna Maria Katarina baroness Würtzburg		marriage: 25. 11. 1675	13. 11. 1696, Graz
3	Maria Rosina Theresa Inzaghi	10. 10. 1679		
	+ Johan Josef baron Webersberg		marriage: 2. 7. 1702, Graz	
3	Franc Joseph Balthasar Inzaghi	before 1685		29. 4. 1685, Graz
3	Anna Maria Francisca Inzaghi	before 1687		5. 11. 1687, Graz
3	Franz Xaver Philipp Inzaghi	before 1688		17. 5. 1688, Graz
3	Franz Philipp Inzaghi	after 1688		1758
3	Franz Johan Alfonz Eugen Inzaghi	12. 4. 1689, Graz		1. 1. 1760, St. Lambrecht
3	Carl Franz Inzaghi	16. 11. 1677, Graz		16. 11. 1744, Graz
	+ Anna Maria von Gaisruck	8. 2. 1690, Graz	marriage: 1708–1713	after 1734, Graz
4	Franc Karl Dizma Sebastian Polykarp Inzaghi	26. 1. 1714, Graz		
4	Franz Anton Inzaghi	1719		1790–1791
4	+ Karolina Thurn Valsassina	1715–1716		17. 5. 1781
4	Maria Anna countess Inzaghi	before 1723		7. 3. 1723, Graz
4	Abundus Inzaghi	before 1729		15. 5. 1729, Graz
4	Franz Philipp Inzaghi	25. 5. 1731, Graz		3. 12. 1816, Solkan
4	Franz Borgia Johan Nepomuk Inzaghi Kindberg	27. 4. 1733, Graz		13. 1. 1818, Graz
5	+ Walpurga (Maria) Dietrichstein	11. 9. 1753, Graz	marriage: 1773	7. 1. 1794, Graz
5	Maria Dismas Josef Johann Valentin Neri Inzaghi	15. 7. 1774, Idrija		26. 4. 1775, Idrija
5	Teresa Maria Ana Josefa Aloisia Serafina Inzaghi	24. 12. 1775, Idrija		11. 9. 1778, Idrija
5	Karl Borromäus Rudolf count Inzaghi	5. 12. 1777, Idrija		17. 5. 1856, Graz
5	+ Maria Elisabet Rosalia Attems	11. 11. 1777	marriage: 3. 5. 1818, Graz	1. 9. 1844
5	Philipp Inzaghi	15. 8. 1781, Idrija		1857, Ober- Rindberg in Styria
5	Maria Johann Josef Valentin Klemen Franz Inzaghi	3. 7. 1783, Idrija		28. 9. 1783, Idrija
5	Maria Franz Anton Serafin Johan Inzaghi	9. 3. 1785		
5	Emanuel Maria Josef Barbara Valentin Ana Inzaghi	5. 8. 1786, Idrija		12. 9. 1786, Idrija
5	Maria Johan Valentin Filip Franz Erasmus Inzaghi	28. 5. 1788		

5	Maria Franciska Serafine Walburg Barbara Inzaghi	27. 7. 1790		
5	Aloysia Inzaghi	27. 11. 1793, Graz		23. 3. 1879
5	+ Ignaz Maria Weikhard Probus Alois Franz Attems	24. 2. 1774		17. 12. 1861
5	+ Rosalia Attems (Second wife of Franz Borgia Johan Nepomuk Inzaghi Kindberg)	19. 10. 1761, Graz	marriage: 19. 1. 1794, Graz	14. 2. 1841, Graz
5	Giuseppe Inzaghi	1794		
5	Maria Louise Inzaghi Kindberg	27. 11. 1794, Graz		
5	+ Ignaz Attems		marriage: 18. 4. 1814	17. 12. 1861
5	Maria Inzaghi Kindberg	20. 8. 1799, Graz		after 1840, Brno
5	Maria Anna Inzaghi Kindberg	5. 3. 1801 Graz		after 1840, Innsbruck
4	Franz Xaver Karl Disma Seraphin Germanus Inzaghi	20. 1. 1735, Graz		
	+ Paula			
5	Karoline Inzaghi			
3	Franc Ignaz Inzaghi Kindberg	2. 1. 1691		1768
3	Maria Karola Inzaghi	before 1699		20. 4. 1699, Graz
2	Inzaghi	about 1645		Como
3	Giuseppe Inzaghi	about 1675, Como		Como
4	Giuseppe Inzaghi			
4	Maria Maddalena Inzaghi	about 1713		1782
	+ Filippo Volta	1692	marriage: 8. 9. 1733	1752
5	Marianna Volta			
5	Giuseppe Volta			
5	Giovanni Volta			
5	Cecilia Volta			
5	Chiara Volta			
	+ Ludovico Reina			
5	Alessandro Volta	18. 2. 1745, Como		1827
	+ Maria Teresa Peregrini	Como	marriage: 22. 9. 1794	
5	Luigi Volta			
2	Johann Anton Inzaghi	1666		after 1686
2	Johann Josef Inzaghi	about 1646		after 1697, Gurinz
2	Maria Theresia Inzaghi	before 1655		19. 3. 1655, Graz
2	Maria Magdalena Inzaghi	before 1655		18. 5. 1655, Graz
2	Maria Elisabetha von Inzaghi	before 1656		29. 4. 1656, Graz
2	Maria Johana Inzaghi	27. 5. 1664 Graz		
	+ Karl Josef count Herberstein		marriage: 24. 11. 1684	
2	Franz Karl Inzaghi	about 1668		1744

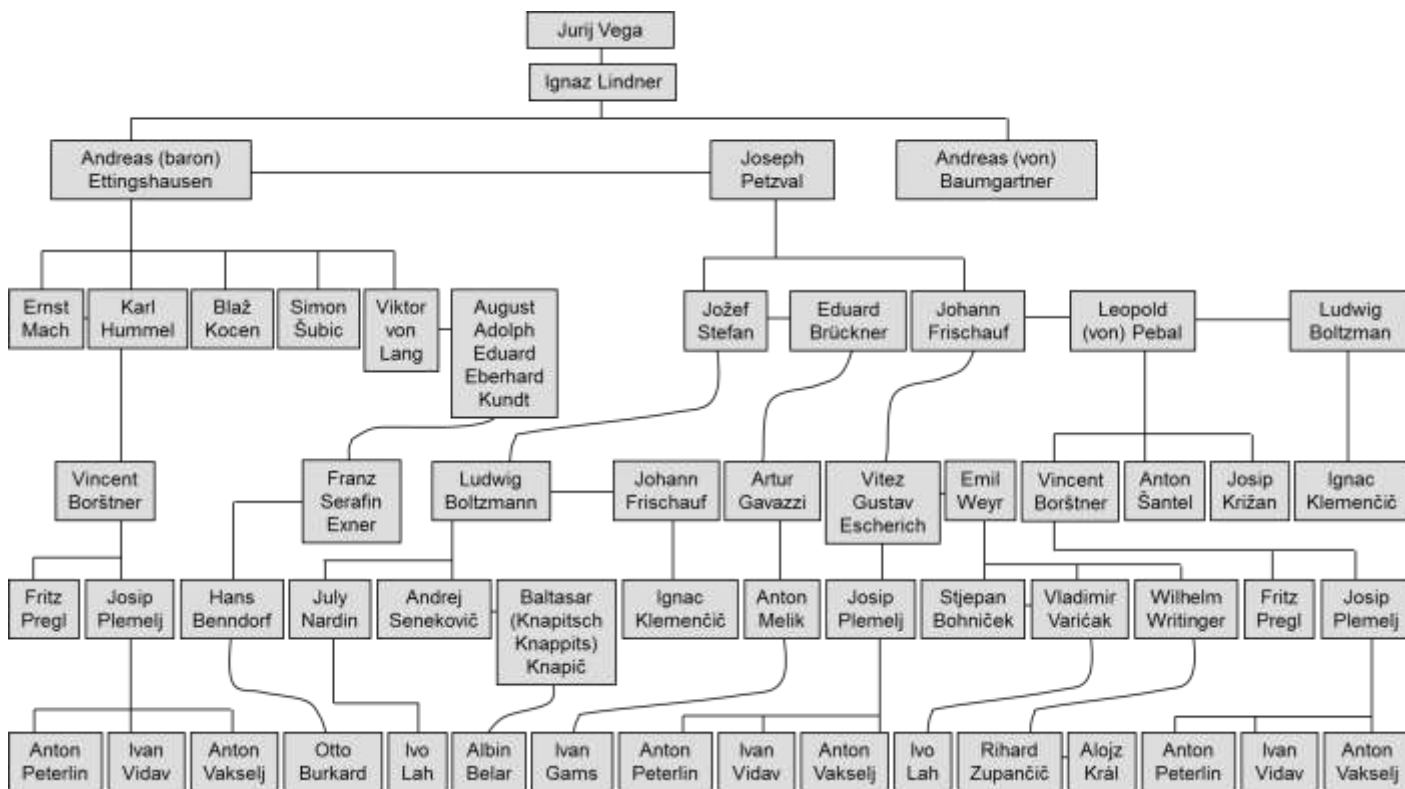

Figure 15-48: Academic ancestors of Vega and other Slovenian users of vacuum techniques through the centuries

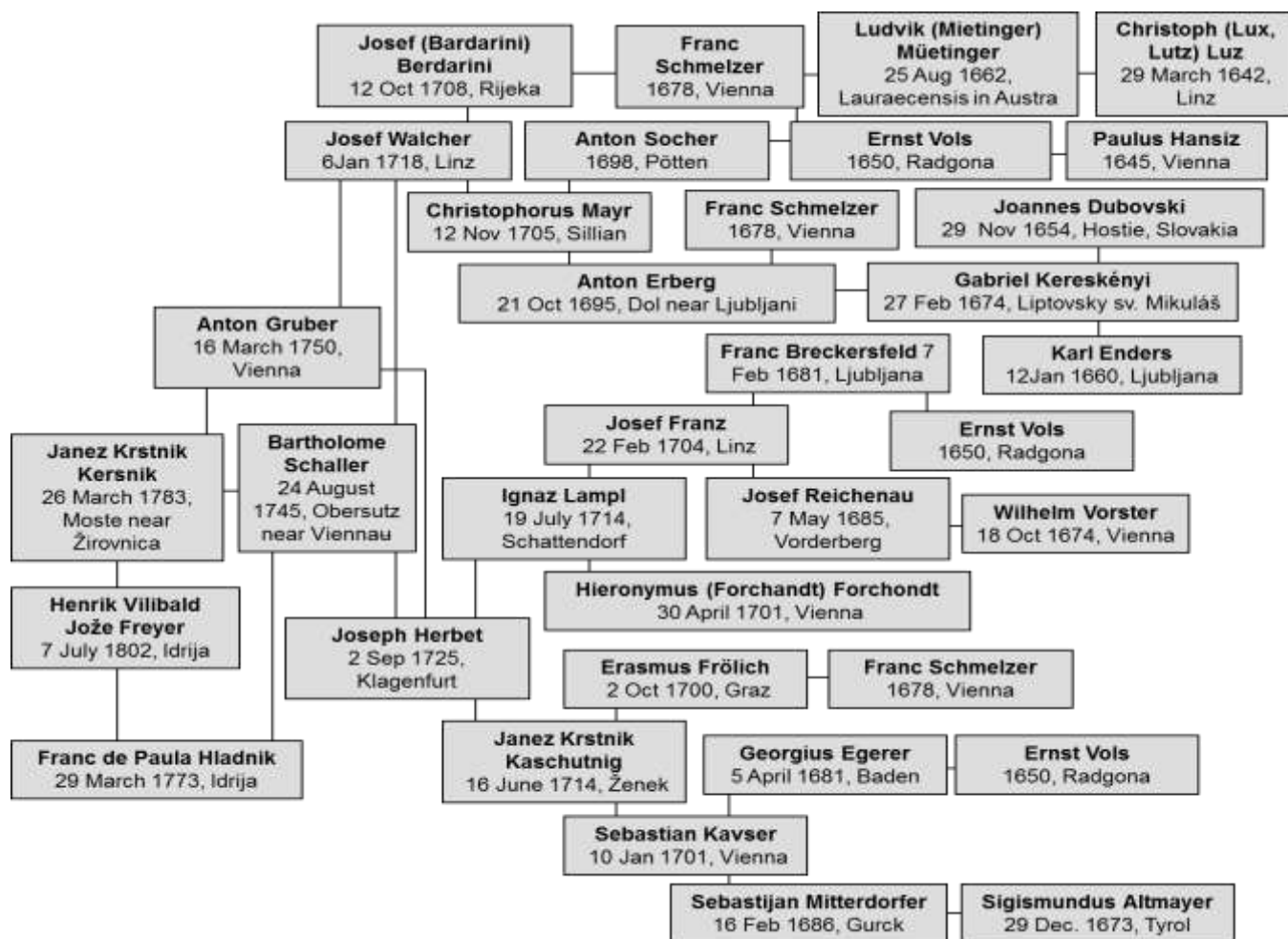

Figure 15-49: Academic ancestors of the professor Henrik Freyer.

The Viennese Jesuits of Gruber family were brothers and not just half-brothers; the facts became evident from the Viennese baptismal and funeral records. The influence of Gruber's brothers on Carniolan everyday life was such that the last third of the 18th century could be called the time of Gruber. Their importance soon spread beyond the Carniolan and even outside the Habsburgian borders. They have decisively contributed to the restoration of the Society of Jesus throughout the world, which, to a certain extent, has always been the main goal of their actions and negotiations. In that context we could interpret Tobias' autobiography, dated October 1804.

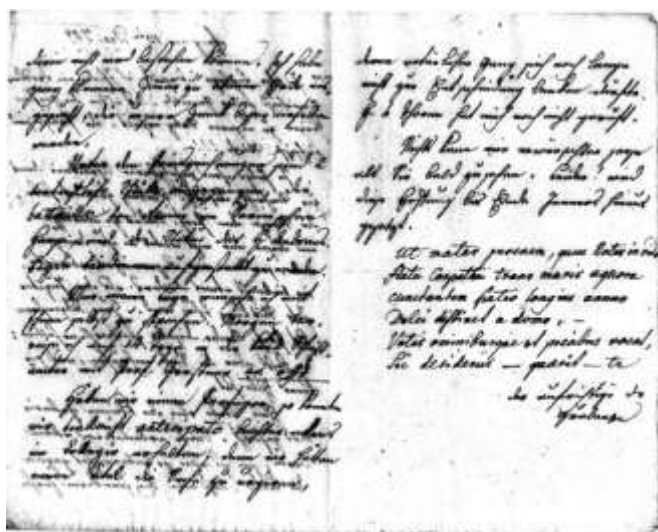

Figure 15-50: Tobias Gruber reports to F. Sternberg about his friend, Professor Gerstner, on the left side of the letter, which on 13 December 1797 concluded with a long Latin poem about exploring of the Carpathians using vacuum portable gauges of Tobias Gruber's own production (Archiv Národního Muzea, Praha, Šternberk-Manderscheid Fund (ŠM) k64).

15.8.2 Evaporation in Vacuum in 1788

In 1788 at his beginning of the paper on the evaporation of water in an empty space, T. Gruber quoted two years earlier research of the barometric tubes of his friend Gerstner. Franz Joseph knight Gerstner (* 1756; † 1832) found that drops of water in the empty space of the barometer flew away and their modifications can be observed under different circumstances. The phenomenon in two successive winters enabled his series of experiments, whose extracts and results were described by T. Gruber in detail in his discussion. He used straight (linear) glass tubes 45-50 inches

long with diameters of 3-4 Viennese lines; today obsolete unit of measure "line" then measured about 2.2 mm. The tubes were almost horizontally sealed at the ends and filled with purified mercury; Gruber bought it in Idrija and boiled it for so long as possible. Cooking and the evaporating of purified mercury vapors at +356.73 ° C is a very dangerous process from the modern point of view, but, despite Hacquet's research, T. Gruber did not know much about these dangers as brothers Gruber used to quarrel with Hacquet.

T. Gruber then used an open tube full of mercury; when it twisted it by half of a full angle, therefore for 180°, the mercury was placed in an equilibrium position balanced with an empty space, at least 30 inches long. So, he got a barometer in Torricellian century old way. To introduce water into the barometer, he used a calibrated glass syringe, whose conical curved end flowed into an opening narrow as hair with a diameter of 1 7/12 lines. During the shaking of the measuring device, the experimenter T. Gruber noticed a compressed mass of water, which climbed by 6 2/5 cubic lines. When the water rose to the surface of mercury, it was squeezed out and created an air balloon, the size of which was very close to the size of the tube's diameter. The mercury level dropped 9 lines right after the splashed squeezing. The collected water can take up more than 3.5 cubic meters of volume while raised to a height of 28 inches and 7.25 lines at 14.9 degrees Réaumur in the area between mercury and balloon of air.¹⁸³⁰

The weight of 9 lines high mercury above the water mixed with air pressed together with the weight of the water mass. When the tube was lowered, the balloon rose by 1.5 lines, which gave a drop of 3 lines and a further 3/4 of a line in the entire barometric vacuum.¹⁸³¹ The evaporation was much slower than in the open air. In the ensuing experiments, T. Gruber endeavored to prove with certainty the conditions in the absence of air or in an empty space; the phenomenon was described like that in water, where the air was also removed. At the first major warming of the empty space with the flame of the spark-burner, only a change in the mercury tube appeared. It received from 0.5 to 5/6 cubic lines of water, enclosed in an empty space,

¹⁸³⁰ The Réaumur scale, without serious use in modern science, endorsed the slightly greater degrees than today's predominant Celsius' scale (in a relationship 1°R = 1.25 °C).
¹⁸³¹ Gruber, 1788, 141.

which enabled Gruber to experiment with the water's dependence of the glass walls. By extending the area of water to the surface of mercury, the last trail of air disappeared. The mercury rose 9 lines at a temperature of 15 degrees of Réaumur. The water formed a ring in the middle of mercury with a taut mercury surface formed as a tense membrane. The mercury in the capillary, unlike the water, does not wet the wall. With the heat of his hands, T. Gruber heated the surface of the mercury in the tube; the water completely evaporated within a few minutes, and in the upper part of the tube made visible droplets. If we take the upper part with the hand, the water will collect under mercury. The empty space was more or maybe less heated.¹⁸³² Thus, with a little heat, water mists and ever-increasing droplets, which are finally placed on the glass, can be quickly obtained. In the middle of the mercury's surface, isolated drops are formed in the form of spherical segments. Gruber experimented at different temperatures of empty space, and mercury had to have a different temperature level compared to the empty space. He looked for the cause in an (averaged) lower triple point of mercury, in a greater attraction with which the increased hemispheres are polling the center, or in both. Even at different temperatures, for example, at -14 degrees of Réaumur, Gruber noticed similar isolated drops. If the temperature is reduced to -17 degrees across the entire device, the drop of the mist will increase, so that mercury is placed only 5/6 lines lower in the barometer. More heating causes large evaporation of mist. With a spark flame that increases the free space temperature by 50 degrees, in the pipe of 4-line diameter mercury will fall by 7 inches 2 1/3 lines below the normal level; in a room with a volume of 2 4/9 cubic inches with a 11/20 cubic line of water, the mist will be invisible.

At a temperature of +80 degrees,¹⁸³³ mercury will be at the level 12 inches and 1 line and the mass of the water of the 2/3 cubic line will be invisible in a larger 2 2/3 cubic inch space. The evaporation of the water at -14 degrees of Réaumur is very small; up to a boiling point at + 80 degrees Réaumur, when the 2/3 cubic inch of water is invisible, the difference is 94 degrees, and the contribution of the empty space to the amount of evaporation is 97: 56.

¹⁸³² Gruber, 1788, 142.

¹⁸³³ Gruber, 1788, 143.

For T. Gruber, as for many modern scholars, a vacuum was nothing in the first place, but it has properties that greatly influence evaporation and related phenomena. In his laboratory Gruber again successfully illustrated events in nature, and his ideas resembled a lot a subsequent cloud chamber (foggy cell) "invented" a century and a half late.

The temperature of the boiling water in the empty space was reached by T. Gruber with a (bleached) iron wire. Gruber attached it to the measuring device as deeply as it was possible in an empty space. T. Gruber warmed the wire to hot melt at 356.73 ° C in a glass tube of a tempered mercury thermometer. The thermometer was so warmed in a certain position that the volume of mercury increased by 1/4 cubic lines in 1/6912 part of the entire space. In the raised tubes, the water reached the surface of the mercury column and squirted a 10 inches high column of water that surrounded the entire thermometer. At +26 °R (30.5 ° C), as brought by the warmth of T. Gruber's palm, he observed a bubble of vapor as big as an approximate diameter of the tube. At +34 °R, as measured at his a warm suit, the boiling of the mist by the ground was already so severe that the water covered the entire empty space without any resistance up to the end of the tube. The measurement level in the thermometer has risen by 1.5 lines. The mean value of several observations was +30 °R according to T. Gruber's calculus. At a temperature of -15 °R, 8.25 inches long closed-water column appeared in an empty space, which increased by a 1/18 of its length by a convex surface.

A closed thermometer received a lot of ice so that the elliptic layers formed on the surface; crystallization on the edge of the glass was generated even at 0 °R, as well as at -15 °R.

The change in the mass of the air for a half-cubic line of water occurred at different degrees of heat. With the known difference between the specific mass of water and air, the dry air in the middle of the splashing was compressed in the same way as under the pressure of the half of a cubic line of water. When Gruber warmed the entire airspace with a sparkling burner, mercury was boiling; the mercury column has risen only 1 inch and 6 lines from the initial value. At ice temperature, the increased distance was only 9 lines.¹⁸³⁴ For pure

¹⁸³⁴ Gruber, 1788, 144–145.

water, the level was only $4 \frac{1}{3}$ of the line above the original state. From these experiments, T. Gruber derived the following conclusions:

the heat in mercury that brings water to boiling temperature is also transferred to the air by heating, so that the mercury column must decrease.

Similarly, air becomes visible in boiling water in an empty space;

the air is, as a matter of fact, a ponderable fluid substance, is extracted just a little bit at the cooking temperature (of water).

The atmospheric air does not appear during evaporation, since it is enclosed in water, where it is further expanded.¹⁸³⁵ When the water is rapidly cooked, the air is placed at different altitudes in its interior, which results in maximum water extraction.

T. Gruber believed in the materiality of heat and fire; in German language it was called Feuerstoff, while for the Slavic people or Frenchmen it was caloric. Such a substance is evaporating in an empty space. More or even less water is eliminated; such fog results only from collisions between substances. At high heat rates the vapour diminishes and hangs on the walls, while the caloric is only transmitted. T. Gruber's caloric resembled the ordinary fluid substances, but much lighter which might have been in accordance with Lavoisier's original ideas announced in those times.

In the same heat rates, T. Gruber allowed only a certain amount of heat lost into space, while mercury remained at the same level and could extract more or maybe less water. For the evaporation in the open air without steam, he also considered humidity in addition to the degree of heat.

The laws of static were not enough for Gruber's explanations of the movement and circulation of the fog (mist) in an empty space,¹⁸³⁶ followed by heavier or lighter particles. Apart from the heat and other intermediaries that go through the glass, there is nothing else. Apparently, the extraction and evaporation of the water affects the mass of water;

so, the steam effected heat or caloric. Similarly happens with other substances penetrating the glass. While the vapor itself forms an intermediate medium where each particle has a certain distance from the other, only the fire in the coming or exiting of the company with other liquids causes refraction between the vapor particles. Gruber did not support the assumption that all water vapor is produced only as bubbles because the vapor is swirling according to the laws of statics.

In these circumstances, the part of swirls go through the hollow body of the vapor as hollow spheres, whose specific weight alone remains the same; on the one hand, the vapor joins with pieces of fire. In the atmosphere, the excessively heated volume of air in addition to its vapors is difficult to describe with static derivatives because of reflections on small parts of the air.¹⁸³⁷

The heat and caloric are compatible with other liquids that pass freely through the glass. Apparently even in an empty space heat and caloric form an intermediate medium; so, much vapor is excreted as the amounts of intermediate particles allow in the ratio of steady amount of steam. This dependence is a consequence of the affinity of steam on fire.

At -13°R , mercury under the vapor space is lifted by an additional 1.5 lines and at -17°R for the additional $\frac{5}{6}$ lines, like that in the barometer; so, it is understandable that the excretion and liquefaction of the vapor can occur only at higher temperatures under the influence of heat and caloric power.

Five years before the writing of T. Gruber, Lavoisier in his *Réflexions sur le phlogistique* (1783) proved that phlogiston opposed the experimental results; so, he replaced it with caloric. As it is always happening, the caloric has cleared up some of the problems, but soon he has come up with whole great ranges of new ones.

In 1798 Count Rumford published *An Experimental Inquiry about the Source of the Heat, which is excited by Friction*. He reported about his observations of drilling new cannon tubes. He proved that caloric is not maintained; T. Gruber accepted Lavoisier's position, but he did not think in Rumford's way yet. Rumford succeeded

¹⁸³⁵ Gruber, 1788, 146.

¹⁸³⁶ Gruber, 1788, 147.

¹⁸³⁷ Gruber, 1788, 148.

Lavoisier in several ways. Among other things, Rumford inherited Lavoisier's widow, which he regretted bitterly. Unfortunately, repentance did not save him from the flying pots of his carelessly chosen Parisian bride, who had all too quickly turned into a dragon. The Gruber brothers as monks mostly avoided such problems.

T. Gruber changed the steam or fog in an empty space with slower or faster evaporation. In the air, under normal conditions, such a rapid and vigorous evaporation does not work. The steam was supposedly connected to the caloric. The dense caloric content more or maybe less retained the steam, which is, therefore, condensed somewhat slower. In this respect, fire seems to be the same as its media: its unified with the vapor and covers the to allow only the motions in the intermediate space.

The fine thin atmospheric air is diluted with heat or by lowering the pressure. More vapor is obtained from denser substances. When passing¹⁸³⁸ through the denser to the thinner air, cloud areas and then precipitation are created. Then the fire again forms a liquefied vapor. It was the same idea of circularity which Tobias' brother Gabriel used to explain the flooding Mountain Field (Planinsko Polje) connected with Ljubljana marshes and Ljubljanica river.

Regardless of the temperature, the pressure rarefies air while the steam is left behind; so, the air is dependent on fire. This can be a good basis for the interpretation of contributions to other phenomena, Gruber added. Among other things, he had in mind a lot of moisture even in the case of reduced heat, humidity in the upper unbalanced areas of the atmosphere or moisture in the form of precipitation.

With the same degree of heat, humidity (vapour) will be less dense than the ordinary air when the humidity and air are equal in their masses. When it's cold, we get even more moisture or fog. At the same heat level, when both (humidity and air) have equal volume but unequal masses, the entire room of moisture-fog at lower temperatures is smaller than the ordinary air space.

From this it follows that fire with high elasticity of vapor-moisture produced by air increases in

proportion to the amounts of spaced spheres (of its molecules). Consequently, humidity in variable intermediate media makes a major change with the increase and diminish of its mass; like the colder air. Gruber tried to prove by his experiments that the elasticity of one and the same volume of air increases with the removal of moisture which would probably challenge the later Dalton's law. The air does not affect the crystallization and expansion of ice.¹⁸³⁹

The crystallization takes place in water with a certain removing of the flames, which adds liquids by secreting its own elements; they make regular crystalline forms according to the laws of attraction. On the other hand, the distances are greater in intermediate space in the liquid (due to water anomalies) compared to the (same) volume of ice, even when it is completely free of air.

Part of the air is transferred to ordinary water; when it rests, an even greater part of the air in other bubbles appears in ice. Gruber explained the anomaly of water with the unmovable hard ice; therefore, it has for 1/1015 smaller volume compared to the volume of boiled water, where it has only 1/1212 of volume of the free air. In a cooked medium, which is removed from the empty space, it retains only 1/18 of the mass of liquid.

There T. Gruber inserted a distinctive remark about different experiments with the translation of substances through an empty space of the barometer. He pointed out only one example: when we cook mercury for the second time, we do not change anything with strong heating of the vacuum; it remains void or has already been emptied.¹⁸⁴⁰ In this way, we can determine the specific weights of different gases and quantities of the fixed air evacuated from the liquid. The latter was the term of the Scotsman Joseph Black (* 1728; † 1799), coined after 1753 for gas, now called CO₂.

Similarly, we define condensation or liquefaction, mixing and synthesis of the substances without considering the air; we can find many other phenomena. This increases the scope of physics with attention focused on the (constituent) particles needed to continue and complement experiments

¹⁸³⁸ Gruber, 1788, 149.

¹⁸³⁹ Gruber, 1788, 150.

¹⁸⁴⁰ Gruber, 1788, 151.

or to continue the experimentation under different circumstances.

Following his research of the barometer in 1788, in 1790/91 T. Gruber published a paper on the particles of the atmosphere, in which deeply he engaged in the atomism of particles of air associated with fire or caloric. He first stated his own finding in 1788: in a vacuum the evaporation of the water is improperly faster than in an air-filled space; in void the water boils at 30 °R (37.5 °C). He imagined fire as fluid inelastic substance; it does not have a reflecting zone associated with the intermediate particles but forms at least a temporary reflecting zone which further prevents the once interconnected substance from reassembling particles of fog into their renewed mutuality in their interim space.

Thus, the fire itself and its repulsive force cause the substance to rise without additives even if its heavier than air. Fire is lighter and less elastic than air; therefore, it tends to rise and distribute throughout the space. Caloric establishes a balance with its expansion into areas with less caloric to achieve a balance in foggy vapour.

Fog with its vapor became denser or diluted due to temperature differences between its warmer and more cold parts, thereby triggering its own circulation.¹⁸⁴¹ The heat influences the mist by wrapping it with warmth, thus allowing the round shape of ordinary drops of mist or fog. More space in the intermediate air means more space for foreign particles. The air, expanded by heat, can also accommodate more foreign particles compared to denser air that has less heat.¹⁸⁴² The higher level of impregnation of free air (with vapours) might make it a subject to the laws of hydrostatics. Weight or mass of the body is always a product of its volume and density. Some traces of rain from clouds never reach Earth's surface.¹⁸⁴³ The areas of clouds have coagulated voluminous vapors. In the lower regions formed along the Earth's surface, the solar rays are highly influential, which T. Gruber proved with a quote from his discussion on *fata Morgana* measured above the lake Cerknica.¹⁸⁴⁴ At some heights, the balls of

vapor are spherical.¹⁸⁴⁵ The equally shaped steam spheres are much more condensing. The process can be so fast that the steam solidifies (after sublimation). Among all the polyhedron that emerge on the vapor balls, Gruber emphasized icosahedra with twelve identical vertices. Twelve spheres of steam form them by actions of caloric, which also affects the transparency of the vapors;¹⁸⁴⁶ of course, it's just about an approximate description. In the correct form of icosahedron smaller bubbles merge and form larger ones. Some of them can become so large that they look like fog or cloud.¹⁸⁴⁷ The steam is formed according to the surface, especially in high mountains. If we measure the vapor density along the whole atmosphere, we get a curved line for the ordinate. It is affected by sun rays, as are heat or cold. Clouds in the atmosphere that alter the mentioned curvature are also adapted to the shape of the Earth's surface; after the split the steam gets a minimal spherical shape, and the amount of caloric in the air decreases to zero at higher elevations.¹⁸⁴⁸ The electric fluid is, of course, part of the atmosphere; its exceptional fluidity and elasticity allow high speed of electricity. Positive and negative electricity is a modification of the same substance or two different; Gruber wrongly considered that the second assumption had good support in experiments, but this or that theory did not affect his model. Positive and negative (electricity)¹⁸⁴⁹ are more suitable for point-contact bodies, where they can form a smooth surface like atmosphere that moves due to air's reflection, as well as because of modifications of steam in balloons; therefore, it affects the recharge of clouds.

The reflecting pairs of balloons of vapours, reinforced with electricity, flow easier, allowing clouds to move in higher areas of the atmosphere. In the footnote, T. Gruber emphasized A. Volta's view that electricity influences the formation of steam; that was Saussure's assumption demonstrated during the numerous experiments described in the third part of his travelogue *Reise durch die Alpen* recently published in Leipzig in 1781-1788. With its high density at the surface of the earth, the bound electrics rise, and with it the

¹⁸⁴¹ Gruber, 1791, 191-192, 192-193.

¹⁸⁴² Gruber, 1791, 194.

¹⁸⁴³ Gruber, 1791, 196.

¹⁸⁴⁴ Gruber, 1786; Gruber, 1791, 197.

¹⁸⁴⁵ Gruber, 1791, 197-198.

¹⁸⁴⁶ Gruber, 1791, 200.

¹⁸⁴⁷ Gruber, 1791, 201.

¹⁸⁴⁸ Gruber, 1791, 202.

¹⁸⁴⁹ Gruber, 1791, 202-203.

sublimated particles of the earth. Mountains within the clouds act as conductors. Thus, electricity (in the atmosphere) is a kind of boundary between air and earth. Positive and negative (electricity) modify the steam, that can affect the atmospheric pressure and the steam curves, all which result in uneven density. The magnetic substance is widespread throughout the atmosphere and its parts and is not separated in its modifications. The magnetic substance can be transformed into electricity to a degree that is defined by the circumstances; this idea of T. Gruber was undoubtedly modern in the frames of then popular romanticism and *Naturphilosophie*, as Oersted proved it only in 1819, and later Faraday adjusted it to electrical engineering.

Indeed, Benjamin Franklin was thinking about the effects of lightning on a magnet earlier, as did Tobias' brother Gabriel Gruber in the then Russian town of Polock in the present-day Belarus.

T. Gruber did not just stop by the caloric, electricity and magnet, but also reflected on the last remaining fluid that was imagined then, without any weight: the light. Light should also occur very often during the spread of caloric in the atmosphere. It spreads on straight lines and is very different from caloric, as it can be seen. Light can affect heat and cold without changing atmospheric pressure. Then T. Gruber went even further with the assumptions about many other fine substances, which science was never able to define. T. Gruber considered that his research enabled him to look at them, although they cannot be easily traced in nature. In further exploration of the atmosphere with various useful types of gases, T. Gruber assumed many not yet discovered substances. The movement of comets looked like balls of steam, assuming that then modern exploration of cold areas by the Earth's poles would bring many new discoveries. When comets from large distances and frosts approach the warmer atmosphere of the Sun, their warmer core emits fluid; this very fine substance makes them visible beyond the Sun. T. Gruber has rhetorically asked: "Is not the stock of fluid substance in the poles (where warmer zones are replaced by colder ones) with the Aurora Borealis the same as comet's material?" Perhaps he had in mind the presumptions of his friend, the Jesuit Maximilian Hell. According to Gruber, we are dealing there with remote modification of the

atmosphere,¹⁸⁵⁰ which at least for the comet is completely nonsense from today's point of view. The fire, light, electricity, magnetic material and many other less-known fluids cannot have the same weight as other substances, but their weight can be indeed demonstrated in the atmosphere; this weight is usually so small as to be detected only by the other (more precise) meters. T. Gruber expressed his different opinion about the parts of the atmosphere and its substance, which is to a certain extent fluid. He thought that these were oils derived from the modifications of balls of steam. He even encountered a semi-fluid substance in the form of refined dust particles raised from the fluids that differed from the atmospheric space because of its (greater) specific gravity. The second component of the atmosphere is reflected in changing of weather, decomposition and rotting of minerals, plants and animals. In solid substances, we have traces of salt. Gruber regretted that it precisely that part of all of them needs the most complicated explanations, although it appears on the surface of the Earth and does not work very far from us.

The reason for the poor knowledge of these phenomena is seen in their movement, which is different from that of fire or heat. We feel the warmth of the Sun¹⁸⁵¹ as halfway through a steam that lies on a heated surface; therefore, the cooling of the Earth causes (dew, frost) to fall during winter nights.

The same ingredients also cause changes in the density of the atmosphere, as well as numerous features. It's a special gift to measure the density and perform the necessary calculations, since measurements can only be carried out in nature. Gruber certainly loved to do that himself with his ppwn designed portable tools. The reduced mass and the volume of a special ponderable substance itself causes a difference in the weight of the atmosphere.

The motion is not merely opposition to pressure; movement of the air particles in the direction of its weight also occurs. All phenomena of gravity are reflected as the consequence of a decrease in force, which in turn opposes the movement. The last result of all these surveys shows the geometric dependence of the density of air on the

¹⁸⁵⁰ Gruber, 1791, 205–206.

¹⁸⁵¹ Gruber, 1791, 205–206.

atmospheric pressure. Thus, by measuring the density and weight of the air, we can obtain the same scale that Professor Gerstner described in his discussion. Gruber's geometric (exponential) dependence was certainly Laplace's barometric equation published only few years later in 1796.

The fire has particles that are not elastic because they do not have the appropriate repulsions between their intermediate particles; in at least one aspect, they have an impact power that lasts for so long as they can efficiently prevent the reunion of the particles. When the flame produces enough particles during the evaporation in the air,¹⁸⁵² then their quantity remains the same to maintain the distance between the separate substances. If there are no other needs, the separated vapor particles will be kept scattered in the space.

The upgraded substance, heavier than air, will only be maintained at distances without any contact due to problems caused by fire and reflection.

The liquid substance is specifically lighter, even if it is more elastic than air; it therefore strives to rise and separates according to the laws that apply at such altitudes. Mutually balancing the substance of a fire to prevent its spread requires a balance between the steam produced, even if it is elevating. The movement of steam depends on the density and the temperature differences.

15.8.3 The Expansion of Gases in a Vacuum

As a physicist, Tobias Gruber loved the problem of formation of ice at the mine pump at Schemnitz (Banská Štiavnica), which was described by Tobias' teachers Scherffer and Poda,¹⁸⁵³ both advocates of Bošković's sciences. The pump was compiled by an elder brother of the leading Jesuit astronomer Maximilian Hell, who rejoined their restored Jesuits' society of Gabriel Gruber like Tobias did. Tobias began publishing his diluted gas exploration in 1788 when he moved from Prague to a long-term works at spa in Franzensbad (Františkovy Lázně). There he investigated the content of gases in mineral water and compared it with the measurements of Tobias' friend the count Franz Hartig (* 1758, Prague; † 1797, Dresden) at

¹⁸⁵² Gruber, 1794, 193.
¹⁸⁵³ Poda, 1771.

the Pyremont Spa in Upper Saxony, southwest of Hannover.

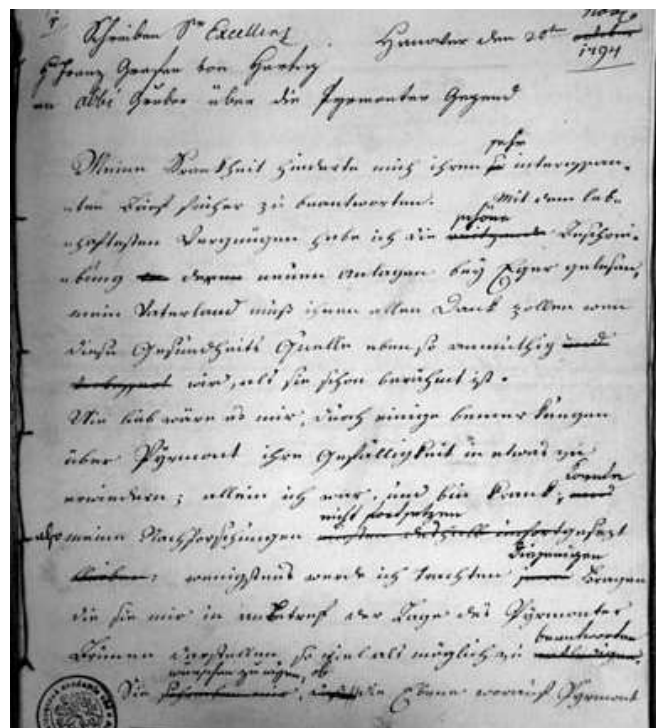

Figure 15-51: The beginning of the letter of the President of the Bohemian Scientific Society Franz count Hartig, sent from Hannover to T. Gruber's Bohemian Lands on 20 November 1794 (Archiv Akademie věd České republiky (Praha) / A. Fondy Institů / Fondy starších vědeckých společností, ústavů a spolků / Královská česká společnost nauk (KČSN) 1766-1953, 75, inventory number 508).

Tobias Gruber opposed Erasmus Darwin's explanations of the spreading of gas, which should always collect heat from the surrounding area. Namely, Gruber was more cautious than Darwin's new theory of caloric, and he thought that the flow of caloric affects the surroundings.¹⁸⁵⁴ Then-current Swiss-German interpretation of adiabatic phenomena has often been opposite to the British opinions, as it also used to be in later centuries. The Brits mainly discussed their puzzles on the meetings of the Lunar Society in Birmingham, of which Darwin, James Watt and Joseph Priestley were prominent members. Many members of the Lunar Society were not only supporters of the American Revolution, but they also loved the French revolution, which the Jesuit Tobias Gruber disliked; as always, the scientific beliefs have intertwined with the political stances. Darwin and

¹⁸⁵⁴ Gruber, 1791; Darwin, 1791.

Jean-André De Luc amongst the first realized that adiabatic phenomena cause compression of the air rather than filling the vacuum; that cognition was like the centuries-old reversal of Galileo or Blaise Pascal, who discovered that nature is not afraid of the vacuum, but the vacuum prevents gigantic pressure from the column of the atmosphere. Darwin and De Luc, therefore, did not favor the vacuum experiments, but Gruber, on the other hand, praised Darwin's wit and often quoted De Luc's achievements even in contrast to Lambert's measurements of the expansion of the air.

Viennese teacher Anton Felkel (* 1740; † after 1798) in 1794. Shortly after Tobias' relocation to the Bohemian lands, Felkel began to compile mathematical tables in collaboration with Lambert, though not exactly with great profits.¹⁸⁵⁵ T. Gruber advised Felkel to produce his small model, an extremely powerful and resistant tripod and a sketch on paper. The measuring device should be simplified to greater degree of accuracy, like that of a microscopic micrometer with a quadrant. With its 8 cm radius it was as reliable as a three-times greater radius. By the way, T. Gruber insisted that Felkel's device be properly handled to ensure effective use. In Prague, Tobias Gruber soon became a leading scholar and art expert, so he was entrusted with the leadership of the Czech Scientific Society (Česká Společnost Nauk), as soon as it gained the imperial patronage. Gruber was elected twice more as the leader, and at the same time he headed the secretariat of the mathematical-science class of society; in the old years he became the secretary of the entire society, the forefather of today's Czech Academy of Sciences.



Figure 15-52: That same Hartig's letter was published in the Bulletin of the Bohemian Scientific Society with the added tables of measurements, and in 1795 it appeared as a separate book.

The researchers needed adiabatic phenomena primarily for the explanation of weather changes. Among Gruber's main sources, the measurements were made by his professor Carinthia native guy Josef Edler Herbert (* 1725; † 1794). T. Gruber extended his study of gases and their specific heat by several years of research with experiments in a vacuum, and he was especially impressed by the compilation of extremely precise portable devices for measuring the pressure, temperature, humidity, angles and boiling point of water. He has climbed up many important peaks of the Sudeten and other hills himself during his scientific journeys with colleagues, and his devices were used for a decade after his death. Gruber's portable vacuum gauges have become so popular that they have been called to evaluate similar devices manufactured by others. Among his assessments was the design of

15.8.4 Vacuum Measuring Instruments

Tobias Gruber proved to be a true artist in the production of vacuum scientific measuring devices. On October 31, 1790, the cousin of F. Sternberg, Joachim; Count Sternberg (* 1754/5, Prague; † 1808), joined the Frenchman Jean Pierre Blanchard when he flew with a warmed air balloon near Prague. The severe storm was the beginning of the ruin of J. Sternberg's most carefully collected measuring devices; followed by a compulsory landing that caused Sternberg to bleed blood. He decided to engage in scientific activities on earth in the future, but not in the air anymore. He was a member of the Česká Společnost Nauk and of the Regensburgische Botanische Gesellschaft, founded on 14 May 1790. On 26 March 1793, Joachim Sternberg described his Petersburg meeting with the Ambassador the Carniolan Ludvik Kobencel (Johann, * 1753, Brussels; † 1809) and Lord James Macartney who traveled to negotiate with the Chinese Emperor. Joachim discussed with mathematicians Euler and

¹⁸⁵⁵ Archive of Czech academy of sciences KČSN box 79, inv. no. 374; box 85, inv. no. 504; <http://www.scs.illinois.edu/~mainzv/exhibitmath/exhibit/felkel.htm>

Shubert¹⁸⁵⁶ about the use of Tobias Gruber's devices for meteorological measurements in Norway and Sweden; Johan Albrecht Euler (* 1734; † 1800) was a member of the Academy since 1766, the conference secretary since 1769 and Leonhard's son. With T. Gruber cooker, Joachim determined the boiling point of water north of Hamburg; he quoted the records from Tobias's travelogue,¹⁸⁵⁷ and personally collaborated with T. Gruber for glassworks.¹⁸⁵⁸ Joachim's brother Caspar Maria Sternberg (* 1761; † 1838) together with Tobias friend Franz Sternberg-Manderscheid co-founded the Vaterländischen Museum in Prague in 1821, and he corresponded with Goethe after 1820.

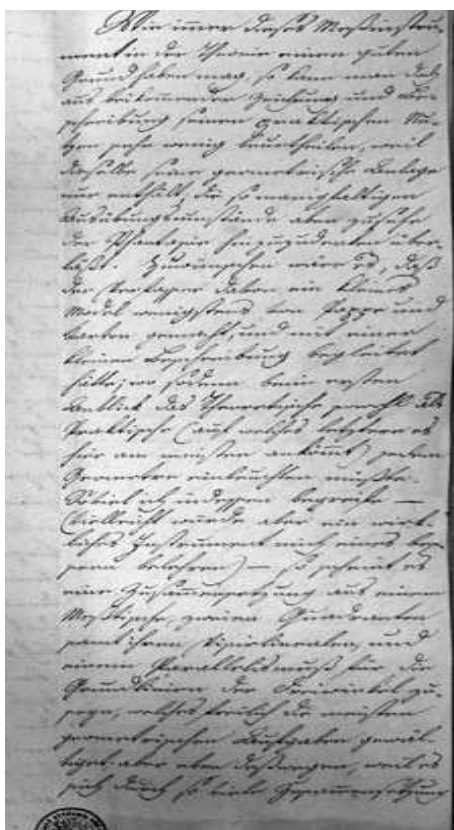

Figure 15-53: The first page of T. Gruber's Book Review of Anton Felkel's vacuum measuring device (Archiv Akademie věd České republiky (Praha) / A. Fondy Instití / Fondy starších vědeckých společností, ústavů a spolků / Královská česká společnost nauk (KČSN) 1766-1953, 75, inventory number 504)

¹⁸⁵⁶ By the error Schubart, in fact astronomer Friedrich Theodor Shubert (Fedor, Ivanovič, * 1758; † 1825), member of academy adjoined in the year 1789

¹⁸⁵⁷ Sternberg, 1793, 3: 407, 4: 2, 10; Gruber, 1781, 199

¹⁸⁵⁸ Gruber's letter to Franz count Sternberg mailed from the spa Františkovy Lázně on 21. 6. 1794 (Archiv Národního Muzea, Praha, Šternberk-Manderscheid Fond (ŠM) k64)

Euler's and Shubert's examination of Tobias' measuring devices has smoothed the way for similar inventions designed by Tobias' brother Gabriel at the Petersburg Academy. The assistant to G. Gruber in Polock, the Bavarian mechanic, blacksmith and watchmaker Franciszek Ksaver Shopfer (Schoepfer, * 1761; † 1808) composed mechanical mills and a cloth cutting device. The invention was first used successfully in the Jesuit factory in Polock; then it was shown in St. Petersburg and Moscow. Peter Aleksevich von der Palen (Pahlen, * 1745; † 1826), the military captain of the capital and the Major Chancellor of the Maltese Order, reported on the new device to the Tsar¹⁸⁵⁹ whom he later helped to kill. In June 1799, when visiting St. Petersburg, Gruber presented some of his inventions in the Academy's premises,¹⁸⁶⁰ among them again scissors for cutting a thin cloth, various pumps and sculptures; he made a great impression and he himself aroused everybody's attention. On this occasion, he met again the Tsar after the Tsar invited him to the Winter Palace in 1789 and after the calligraphic description of the proposal by Franciscus Xaverius Kareau (Karü, * 1731; † 1802) for the presentation of the Jesuit mechanics to the Petersburg Academy. In the Winter Palace G. Gruber enjoyed the company of J. Benislavsky, who became the Russian Catholic metropolitan in 1800.¹⁸⁶¹ The academicians, professors of mathematics Semen Emelyanovich Gurev and Semen Kirilovich Kotelnikov were interested in G. Gruber's works in the hydrodynamics. Gurev studied hydraulics in England in 1792, and Kotelnikov studied under supervision of the professor Abraham Gotthelf Kästner in Leipzig between 1751 and 1752 and helped to built the unfinished Volga-Don canal. Similarly, G. Gruber used Kästner's textbooks during his works on the Ljubljana canal.

On 6 August 1795 T. Gruber presented a vacuum thermometer and a barometer of his own production in the letter to Ferenc Count Széchényi (* 1754, Fertőszéplak; † 1820, Vienna), the founder of the Hungarian National Library and the National Museum in Budapest. In those days, T. Gruber expected a visit of Ferenc and his wife in

¹⁸⁵⁹ Zalenski, 1886, 73

¹⁸⁶⁰ In the years 1743 to 1803 it was called Императорская Академия Наук и Художеств (Imperatorskaâ akademija nauk i hudožestv).

¹⁸⁶¹ Čurkina, 1981, 107; Ingot, 1997, 98, 149; Moroškin, 1867, 1: 370; Zajc, 2011, 17

Table 15-9: Important life events of Gruber's family

Time	Gabrijel	Tobias	Anton	Mother Josefa, born Huber and her husbands
1719				Birth in Vienna
				Wedding with armory Tobias Abraham Gruber
1740	Birth in Vienna			
1744		Birth in Vienna		
1750			Birth in Vienna	
1751				Death of her first husband
18. 10. 1755	Joins the Jesuit			
18. 10. 1760		Joins the Jesuits		
1760–1773		Studies with the Jesuits		
18. 10. 1765			Joins the Jesuits	
1768	Arrival to Ljubljana			
1773/74	Ljubljana Canal (9. 3. 1771–December 1777)	Supplies Walcher's lectures at the University of Vienna		She and her second husband settle in the villa Podrožnik
1774–1777	Navigation Director (4. 6. 1772–1. 5. 1781)	Navigation director in Timisoara	Gabrijel's assistant in Ljubljana	
1777–1780		Exploration of karst in Carniola and Venetia		
1780–1806		In Prague, for several years in Františkovy Lázně and in nearby Cheb (1788-1794) ¹⁸⁶²		After Tobias' departure, his stepfather replaced Tobias as a member of the Carniolan Society of Agriculture and Useful Arts
1785	Departed to Russia			
1787				She died in her Ljubljana villa Podrožnik
24. 4. 1788–14. 9. 1802			Prof. of Math. at Philosophical Studies in Ljubljana	
10. 10./22. 10. 1802	Elected General of the Jesuits			
1796, 1798, 1801, 1805		Many visits to the Viennese galleries		

Table 15-10: Gruber references in the study of thermal phenomena in the vacuum

Year and page	Author	Title ¹⁸⁶³	Year of print
1791/189	Franklin ¹⁸⁶⁴	1ster Brief über die Erkaltung	(1758)
1788/139; 1791/194	Gerstner	Theorie des Barometerhöhen	(1791)
1791/190	Gruber	Versuche	1788
1791/191	Saussure ¹⁸⁶⁵	Gebirgsreisen, 3ten Theil	1784-1796
1791/188, 195, 197	Darwin ¹⁸⁶⁶	(Frigoric Experiments)	(1791)
1791/192	Gruber	Ueber die Bestandtheile	1790
1791/190, 194, 195	Gruber	Beobachtungen	1791

¹⁸⁶² Gruber, 1794, 163, 193–195¹⁸⁶³ In parenthesis are data which Gruber did not list.¹⁸⁶⁴ Benjamin Franklin (* 1706; † 1790)¹⁸⁶⁵ Horace Bénédict de Saussure (* 1740; † 1799)¹⁸⁶⁶ Erasmus Darwin (* 1731; † 1802).

Prague. T. Gruber mentioned a letter of Bohuslav Baron Hasištejnský mailed to Lobkowitz on July 30, 1795. T. Gruber also noted Johann Rudolf Count Czernin von Chudenitz (* 1757; † 1845), Sternberg, T. Gruber's friend Dr. Jan Mayer, the general František Josef Kinský and Abbé Gibling (Josef Kiblin).¹⁸⁶⁷

15.8.5 Conclusion

Tobias Gruber's enrollment in the Masonic Lodges enabled Gruber's rapid progressions on the Prague social networks. The Masonic Lodges socialized the most influential Bohemians, as the best part of Czechian nobles joined freemasons of those days. The freemasonic lodges were also visited by Mozart whose music was especially popular in Prague. The freemason Tobias successfully helped his brother Gabriel Gruber, who led scientific, school and diplomatic efforts to restore the Society of Jesus in Russia. As it happened to many other contemporaries, Freemasonry of Tobias Gruber was by no means in the oppositions of his love for the Jesuits. As soon as Gabriel's efforts made it possible, Tobias renewed his Jesuitical vows early in 1804 and joined the Jesuit of General Gabriel Gruber, who at that time successfully renewed the vows of the former Jesuits in Vienna, America, and China. Unfortunately, Tobias and Gabriel Gruber did not come to see the official restoration of the Society of Jesus in 1814, for which they sacrificed a large part of their powers.

The Gruber family was the true blessing for Ljubljana; it's a pity that they were Jesuits, and they did not create mathematical-technical dynasties with their descendants, like, for example, Bernoulli family! Of course, their view of useful science was not uniform, although Gabriel, Tobias and their stepfather used to be prominent members of the Carniolan Society for Agriculture and useful Arts.

At least in his later years, Gabriel Gruber's technical knowhow undoubtedly became his basic tool in gaining political reputation. Anton Gruber was a highly pedagogically oriented mathematician at a time when mathematics covered a good part of physics with vacuum devices included; Anton's

hobbies were the flowers. Andrej Janez Schwindl, their stepfather, was mainly involved in agriculture. Only Tobias could at least partly be called a professional scientist from a modern point of view, but in the autumn of his life, he focused mainly on art and collecting. Despite of differences, however, Gruber's family obviously had an important common point, which was a commitment to the Jesuit order. They worked heartily to restore it and - succeeded.

15.9 Gruber on the Spread of Gases into a Vacuum

15.9.1 Introduction

Two centuries ago, the Viennese Gabrijel Gruber (1840-1805) died in St. Petersburg; he was one of the most important professors of mathematics, architecture and engineering in Ljubljana. Together with his younger brother Tobias, they wrote about many branches of natural science. They mostly observed and experimented. It is less known that they also dealt with vacuum technique in the research of the operation of pumps.

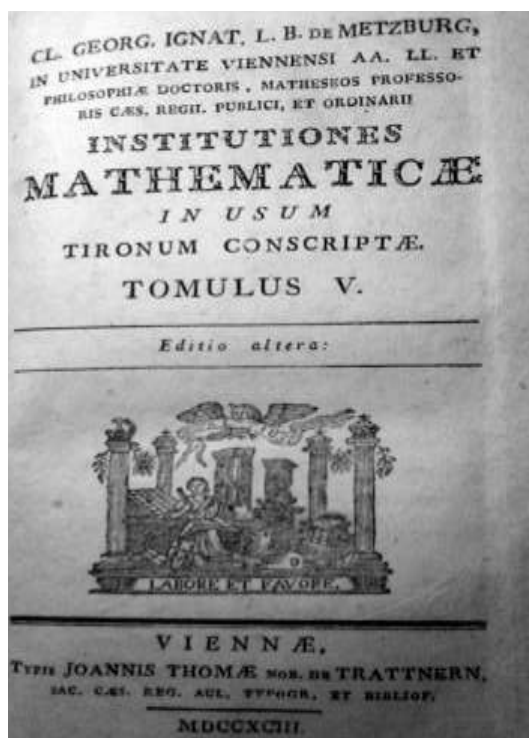

Figure 15-54: The title page of the fifth of seven parts of Metzburg's book in the Franciscans library of Ljubljana (Georg Ignac Metzburg, 1793, FSLJ-14 d 32). The book dealt with aerometry with vacuum techniques and hydraulics

¹⁸⁶⁷ <http://www.mek.oszk.hu/01600/01644/01644.pdf> p. 152–154, 213

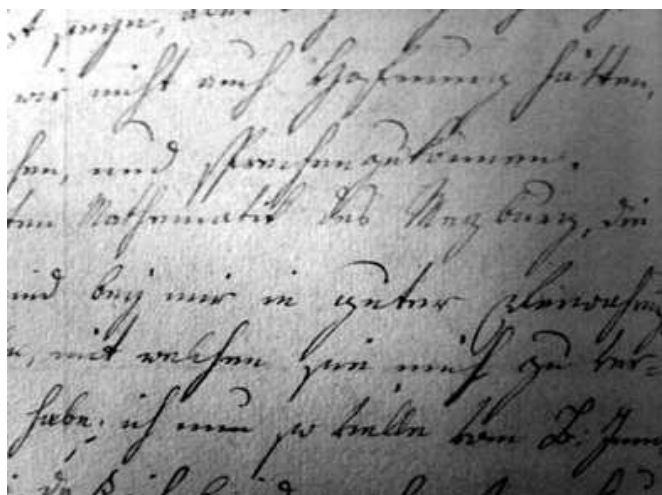

Figure 15-55: The fourth line of the second page of the Ljubljana letter of A. Gruber mailed to the Viennese Metzburg's student Jožef Kalasanc Baron Erberg, in which he thanks him for delivering Metzburg's book on 6 October 1790 (AS 730, Gospostvo Dol, fasc. 43, 1337). Erberg and G. Gruber had one Latin and another German language edition of Georg Ignatz Metzburg's 1775, 1776, 1777. *Institutiones Mathematicae in Usum Tironium conscriptae*. 1-3. Vienna: Typis Joan. Thomae Trattner. I-V. (Erberg-M41; NUK-4281); Translation A., X. G.: 1798-1804. *Einleitung zur Mathematik*. Wien: F. J. Rotzel. I-VII (Erberg-M42; NUK-4281).

15.9.2 T. Gruber on Thermal Phenomena in Diluted Air (1788, 1791)

T. Gruber was the world's first laboratory researcher of a total reflection at the heated and colder air interface. The experiments were related to the reduction of the density of warmed air; so, he studied phenomena in diluted air. In Prague and Leipzig, he published two papers on the cooling of the gas in the lower pressure zones.

In 1788, Gruber referred to the barometric measurements of his friend, professor dr. Gerstner.¹⁸⁶⁸ Gerstner determined the height of the summits of Sudetes with his barometer. He measured in two consecutive winters. By weighing air at different pressures, he tried to prove the logarithmic alteration of density with a height¹⁸⁶⁹ according to the Laplacian barometric equation published later in 1796. Gerstner relied on the

measurements of Pascal,¹⁸⁷⁰ Bouguer,¹⁸⁷¹ Guericke, Mariotte¹⁸⁷² and the professor of mathematics, state councilor Kästner.¹⁸⁷³ In 1866, the Celovec (Klagenfurt) professor of physics, Robida,¹⁸⁷⁴ published a slightly modified barometric equation.

Gerstner completed his studies of philosophy at the Jesuit college in his native Chomutov in Sudetenland; then he studied mathematics and astronomy in Prague. He researched in the Prague observatory and taught mathematical subjects. He established technical high schools in the German language space by founding a polytechnic school in Prague in 1806; as its director, he was inspired by the Paris École Polytechnique.¹⁸⁷⁵ He scientifically assisted the renovation of the Vltava-Danube River canal. Therefore, in 1811, he was appointed as a senior water management director in the Bohemian Lands. During the preparations for constructing the expensive canal between Vltava and the Danube near Vienna, the project was replaced by a cheaper horse-drawn railway and later by steam railway locomotives. Together with his son,¹⁸⁷⁶ he encouraged the construction of the first horse-drawn railway in the monarchy between Budweis (Ceské Budejovice) and Mauthausen; later in 1822, the rails were set up to Gmunden and Linz. It was the first railway on the European continent. Later, their program was complemented by Riepl¹⁸⁷⁷ between 1829 and 1836. On 14 September 1784, Gerstner entered the masonic lodge Zur Wohlthätigkeit and he was also a correspondent member of the Zur Eintracht Lodge. Jurij Vega quoted him as a colleague scientist, and, of course, also as his freemason brother.

T. Gruber, together with Gerstner, assumed that the amount of mercury in the barometer is strongly influenced by the evaporation of water in the empty space. He believed in the theory of caloric, which freely passes through the glass of the

¹⁸⁷⁰ Gerstner, 1791, 273.

¹⁸⁷¹ Pierre Bouguer (* 1698 Bretagne; SJ; †1758 (Gerstner, 1791, 274)).

¹⁸⁷² Gerstner, 1791, 275.

¹⁸⁷³ Gerstner, 1791, 277.

¹⁸⁷⁴ Karel Robida (* 1804; † 1877).

¹⁸⁷⁵ Rosner, 2002, 115.

¹⁸⁷⁶ Franz Anton Gerstner (František, * 1796; † 1840).

¹⁸⁷⁷ Franz Xavier Riepl (Laurenz, * 1790 Vienna; † 1857 Graz).

¹⁸⁶⁸ Franz Joseph knight Gerstner (* 1756; † 1832).

¹⁸⁶⁹ Gruber, 1788, 139; Gruber, 1791, 194.

barometer.¹⁸⁷⁸ He described the crystallization and expansion of ice in cooling, with the assurance that air does not affect the crystallization.¹⁸⁷⁹ Similarly, G. Gruber's co-workers from Ljubljana assured that salt is not necessary for the formation of ice. Of course, later it turned out that air pressure and salt lowered the temperature of melting of ice; but this did not contradict the fact that untreated water can freeze in an empty space.

Cullen¹⁸⁸⁰ began the investigations of adiabatic phenomena of real gases while he studied the cooling upon evaporation. In a vacuumed vessel, he measured the temperature change by a few degrees when the air was pumped or drawn from the container. Initially, he was a pharmacist and a doctor, then became a professor of chemistry and medicine at the University of Glasgow. This was a very successful decision, since Cullen's student became the later famous Black,¹⁸⁸¹ who received his doctorate in medicine in 1754. Cullen became a professor of medicine in Glasgow in 1751, and immediately after experiments with adiabatic phenomena, he took over the department of chemistry in Edinburgh in 1756. In 1766, he moved to the department of medicine, while at the same time he taught physics until 1773. He was superb teacher and taught almost until his death.

Soon after Cullen, Arnold¹⁸⁸² supplemented his research on adiabatic phenomena in a vacuumed vessel. He published the discussion in his dissertation for habilitation for professor of physics at the University of Erlangen. Both Cullen and Arnold had adiabatic cooling for a basic consequence of evaporation of water. Arnold attributed the adiabatic heating to friction between the air flow and the thermometer. Lambert¹⁸⁸³ had already seen Arnold's experiment in 1761. Cullen's and Arnold's results were explained by changes in the density of the particles of the flame in the vacuumed vessel.¹⁸⁸⁴

A clear distinction between Swiss-German and Scottish surveys is shown by Scotsman William

Cleghorn, who linked adiabatic phenomena with the substantive theory of heat in 1779. With the same assumptions, he explained both cooling and heating. He first emphasized that the change in temperature is caused only by thickening or diluting of the gas. In 1745, Cleghorn took over the moral philosophy department at the Edinburgh University after his client withdraw the support for his rival the renowned philosopher Hume.¹⁸⁸⁵ Most researchers did not consider Cleghorn's findings. Among the few exceptions was the posthumous edition of Black's lectures in Edinburgh. Of course, Black received his PhD degree at the time of Cleghorn's death.¹⁸⁸⁶

In 1783 Lambert's interpretation was accepted by Saussure, and Gruber read it. On 1 January 1791 Gruber investigated the phenomenon first observed at the mine pump in Schemnitz (Banská Štiavnica) in Slovakia in 1758. He certainly had his own experience as Gabriel Gruber renewed the hydraulic pump by Sava river in Kranj near Ljubljana in 1770.

On 23 March 1753, a pump was built by Josef Karl Hell (Jozef Karol Höll; * 1713 Štiavnické Bane; † 1789 Banská Štiavnica (Schemnitz)), the elder brother Maximilian Hell and Ignaz Cornel Hell. It operated in Schemnitz without a propulsion engine, driven by the difference in hydrostatic pressure. The brother Maximilian, who taught at the same time in the nearby town of Banská Bystrica, helped J. K. Hell in his calculations. Hell's pump was very well known, and the Americans used it almost a century later to pump oil in Pennsylvania.

When the compressed air from the pump in Schemnitz was pumped through the valve, snow accumulated on the valve. In the Hell's type pumping of a water column higher than 40 meters, the air under high pressure, while expanding into the atmosphere, imposed solid ice on every object along its way. The royal physician botanist fellow of RS Nataniel Mateusz Wolf from Warsaw and Jars described the phenomena among the first.¹⁸⁸⁷

¹⁸⁷⁸ Gruber, 1788, 148.

¹⁸⁷⁹ Gruber, 1788, 150.

¹⁸⁸⁰ William Cullen (* 15. 4. 1710 Hamilton; † 5. 2. 1790 Edinburgh).

¹⁸⁸¹ Joseph Black (* 1728; † 1799).

¹⁸⁸² Johann Christian Arnold (* 3. 2. 1724 Weissenfels; † 9. 7. 1765 Erlangen).

¹⁸⁸³ Johann Heinrich Lambert (* 1727; † 1777).

¹⁸⁸⁴ Kuhn, 1958, 133-134; Fox, 1971, 47.

¹⁸⁸⁵ David Hume (* 1711; † 1776).

¹⁸⁸⁶ Fox, 1971, 47, 335.

¹⁸⁸⁷ Gabriel Jars (* 1732; † 1769); Wolf *Descriptio Fontis Hieronis in Metallifodinis Chemnicensibus in Hungaria, Anno 1756 Extracti; Auctore – Wolfe (Wolf), M. D.* Communicated by Mr. Henry Baker, F. R. S. *Philosophical Transactions* (1761) 52: 547-554 (Wolfe's description of Hero's fountain at Schemnitz).

Initially, G. Gruber's professor of physics in Graz Poda investigated Hell's pump and suggested improvements. Born published his Book Review of the Poda's description. Already after 20 s to 30 s, ice was collected at the end of the tube without a physical cause,¹⁸⁸⁸ which the then learned observers could explain. In 1773, Hell's pump from 1753 was described and drawn by Gruber's Viennese mathematics teacher Scherffer at the end of his hydrodynamic textbook for students of the Jesuit philosophical classes just before the ban of Jesuitical order. However, Poda did not care much about the formation of ice, but he investigated much more the mechanical functioning of the pump. He liked the most shut-off valves, which he drew out in detailed picture.¹⁸⁸⁹ So, in his Viennese class Scherffer acquainted both his students, Gabriel and Tobias Gruber with Hell's invention, which had a particularly heavy weight among the Jesuits because of the highest position of inventor's brother the Jesuit Maximilian Hell.

Erasmus Darwin (1731-1802), the grandfather of the famous Charles Darwin,¹⁸⁹⁰ repeated Cullen, Arnold and other experiments in 1773 and 1775. In 1784, in a letter to potter Wedgwood,¹⁸⁹¹ he reported experiments in which the air is always taking heat from the surrounding area. Wedgwood developed his potter workshop with scientific knowledge and became the queen's potter; in 1783 he was elected became fellow of the Royal Society in London. Together with Watt, dr. William Small, Darwin, Watt's assistants Murdoch¹⁸⁹² and Priestley he was a member of the Lunar Society in Birmingham. They met at the full moon to be able to return home sober in the unspoken roads until the riots, during which Priestley's house was burnt in 1791.¹⁸⁹³

Before the 19th century Darwin and De Luc were the only researchers who realized that adiabatic phenomena cause compression of the air, rather than their filling of the vacuum. Therefore, they were not particularly hot for experiments in vacuum. De Luc criticized William Irvine's (1743

Glasgow-1787) and Adair Crawford's theories. Although he was of the Swiss origin, De Luc traveled a lot and, after settling in England, he departed from the Swiss-German description of adiabatic phenomena which was contrary to the British views. Like Leslie¹⁸⁹⁴ and John Murray¹⁸⁹⁵ of the University of Edinburgh, De Luc did not distinguish between specific heat at constant volume and at constant pressure.¹⁸⁹⁶ In 1819 Leslie separated three ways of heat transfer: radiation, convection (mixing) and translation.

In the year 1784, Darwin and Fox¹⁸⁹⁷ studied cooling by sudden release of compressed air from the vessel, which caused the water vapor to freeze the air on valve of the pump in Schemnitz. On 13 December 1787, in his paper read before the Royal Society he noted that he could freeze even mercury through such a procedure. He was thinking about the cold in the higher altitude of the atmosphere, where at a lower pressure the air expanded and cooled. He described the adiabatic changes involving meteorology correctly, but his ideas did not have a big echo. He was thinking of a rocket propelled by oxygen and hydrogen fuel, of steam turbines, a multi-mirror telescope and a steam powered carriage.¹⁸⁹⁸

Gruber and a chemistry professor at the Medical Faculty at the University of Halle, Gren,¹⁸⁹⁹ have criticized Darwin. Darwin's ideas were accepted by Scotsman Hutton,¹⁹⁰⁰ whom Darwin introduced in 1774 to the Lunar Society in Birmingham. Darwin's views were also,

advocated by Cavallo,¹⁹⁰¹ who became famous for testing paper balloons in 1782.¹⁹⁰² Cavallo was a member of the Royal Academy in Naples, and in 1803 he settled in London. Gruber could find many Cavallo's works in the Zois' Library of Ljubljana.

¹⁸⁸⁸ Born, 1771, 59.

¹⁸⁸⁹ Scherffer, 1773, 123-124, fig. 93, 94.

¹⁸⁹⁰ Charles Darwin (* 1809; † 1882).

¹⁸⁹¹ Josiah Wedgwood (* 12. 7. 1730 Burslem; † 3. 1. 1795 Etruria).

¹⁸⁹² William Murdock (Murdoch, * 1754 Bellow Mill; † 1839 Soho).

¹⁸⁹³ Priestley, Autobiography 1966, 375; Fox, 1971, 57, 58, 79-80; Schiffer, 2003, 72.

¹⁸⁹⁴ Sir John Leslie (* 1766; † 1832).

¹⁸⁹⁵ John Murray (* 1778 Edinburgh; † 22. 7. 1820 Edinburgh).

¹⁸⁹⁶ Fox, 1971, 48-49, 52-53, 158.

¹⁸⁹⁷ Probably Samuel Fox, the husband of Erasmus's relative Anna Darwin and the father of the politician William Darwin Fox.

¹⁸⁹⁸ Schiffer, 2003, 104.

¹⁸⁹⁹ Friedrich Albrecht Carl Gren (* 1760; † 1798).

¹⁹⁰⁰ James Hutton (* 1726; † 1797).

¹⁹⁰¹ Italian Tiberio Cavallo (* 1749; † 1809).

¹⁹⁰² Fox, 1971, 57, 59, 337; Rosenberger, 1890, 74.

Gruber criticized Darwin's assumptions as they did not seem sufficiently supported by experiments. He accepted Franklin's idea of the electric nature of heat transfer. He quoted Franklin's letters in their German¹⁹⁰³ translation, which the Jesuits of Ljubljana acquired in 1761, three years after the print. In his library, Ž. Zois had a French translation of Franklin's works, in which the translator criticized Franklin's theory.

Franklin's theory supported Saussure's experiments. Saussure's barometers of special manufacture were purchased at the same time in Ljubljana's Lyceum. Between 1762 and 1784, Saussure was a professor of philosophy at the Academy in Geneva. Between 1758 and 1779 he studied the geology and meteorology of the alpine glaciers. He first climbed to the top of Mont Blanc in 1787. His son, Nicolas Théodore de Saussure (1767-1845), explained the photosynthesis discovered by Dutchman Jan Ingenhousz (1730-1799) in Vienna in 1779 just before returning to London. Gruber cited H. B. Saussure's travelogues with the German title as he read his work in a translation that appeared between 1784 and 1796. Saussure published measurements with a special hygrometer on the hair isolated under the bell. He determined the quality of the air with the eudiometer on nitric oxide (NO), which the erudite of those times considered as the important experimental device comparable to a thermometer or barometer. He agreed with Volta that the evaporation is a source of electricity in the atmosphere.¹⁹⁰⁴

Gruber disagreed with Darwin that mechanical stretching takes heat from the body. He considered that the dilution of caloric fluid only affects the bodies nearby. According to Gruber, denser air does not emit heat to the surrounding area. In his calculations, he used his three-year-old measurements of boiling water's dependence on external pressure.¹⁹⁰⁵ In his study of the relationship between water vapor and air volumes, he referred to his discussion in which he described electrified clouds as thermal insulators in 1790.¹⁹⁰⁶ With the assumption of colder upper parts of the atmosphere, he explained the origin of the hail. He

correctly observed that there is a similar tide in the atmosphere than in the oceans.

Darwin assumed that the mercury level in the barometer determines the pressure of the lower elastic layers of the air. The pressure is also influenced by rain, which changes the amount of acid (CO₂) in the atmosphere and the air density during the rainfall. Because of altering the altitude of mercury in the barometer at the rain, Gruber relied on his travelogue discussion, which he had just "published" in Dresden. He wrote it together with Gerstner and other colleagues for a scientific society in Prague. He illustrated his model of the atmosphere by the results of experiments with the air pump. Later G. Gruber exhibited a similar air pump at the Academy in St. Petersburg in June 1799 where it was admired by Russian dignitaries.

In Gren's concluding remarks about Gruber's critique of Darwin, Gren took Gruber's side. The publisher of both their works Gren earlier published the translation of Darwin's discussions. According to Gren, the losing of heat in Hell's pump cannot be explained by the mechanical effects of the diluted air in Darwin's way. Gren agreed with Gruber that the phenomenon is caused by the heat flux, therefore by then popular caloric.¹⁹⁰⁷

Darwin assumed that the mercury level in the barometer determines the pressure of the lower elastic layers of the air. The pressure is also influenced by rainfall, which changes the amount of carbonic acid in the atmosphere and the air density during the falling of rain drops. Gruber relied on his travelogue discussion on the causes of changing the level of mercury in the barometer when raining.

Gren and Gruber were determinately strongly committed to gradually prevailing (Lavoisier's) theory of caloric of that time, while Darwin was more cautious about Lavoisier's caloric maybe also because Lavoisier lost his head soon after quarrels between Darwin and Gruber. Darwin might even had some nationalistic obstacles on the eve of English global conflicts with the French. Gren and Gruber believed in applied dynamic theory of Bošković or Kant and did not care much for the atoms in Dalton's networks; Gren even published a manual of physics and chemistry following the

¹⁹⁰³ Gruber, 1791, 189.

¹⁹⁰⁴ Gruber, 1791, 191; Rosenberger, 1890, 70, 523.

¹⁹⁰⁵ Gruber, 1791, 190.

¹⁹⁰⁶ Gruber, 1791, 192; Gruber, 1790, *Ueber die*

Bestandtheile.

¹⁹⁰⁷ Gruber, 1791, 197.

ideas of Immanuel Kant.¹⁹⁰⁸ Gren edited the magazine *Journal der Physik* between 1790 and 1794, and later he edited the *Neues Journal der Physik* until 1798. These were the predecessors of *Annalen der Physik*, the leading German physics journal of the nineteenth century. Gren considered that the new Lavoisier chemistry could be combined with the older Stahl's phlogiston; Gren was therefore criticized by the opponent of phlogiston, the German of the Swiss genus Girtanner¹⁹⁰⁹ who researched and manufactured salt near Edinburgh where E. Darwin had previously studied medicine. The caloric ideas soon found their echo among the people of Ljubljana, when the governor of the Illyrian provinces Marmont initially firmly believed that he was able to weigh the caloric in his lab designed at the bishop's palace by the cathedral; the poor bishop of Ljubljana had to leave his residence, of course.

Gruber and Darwin dealt with adiabatic phenomena attracted them by their mutual interests in the meteorological phenomena. At the end of the 18th century, meteorological effects were mostly explained by adiabatic phenomena. There were few reports published in the French language. In 1790 Chaptal¹⁹¹⁰ reported about Cullen's exploration of the air pump, but accidentally attributed its whereabouts to evaporation.¹⁹¹¹ The son of the pharmacist Chaptal was initially a physician and professor of chemistry in Montpellier; between 1800 and 1804, as Napoleon's interior minister, he helped to establish a new European policy along with the Jesuit general Gabriel Gruber.

In 1792, the Swiss Pictet,¹⁹¹² known for his exploring the reflection of infrared rays, investigated adiabatic phenomena in the formation of fog with the ancient Heron's overpressure reaction burner, which was also obtained by the Jesuits of Ljubljana in 1755. According to the

theory of caloric, Pictet considered that heat was excreted from gas similarly as water from the mushroom. He was Saussure's disciple and friend and took over his chair of philosophy at Geneva University.¹⁹¹³ Pictet was a close friend of Count Rumford,¹⁹¹⁴ just like the Carniolan Jurij Vega. Pictet also collaborated with the friend of Žiga Zois, Déodat de Dolomieu.

Delamétherie took over the editing of the influential *Journal de Physique*, founded by Abbé Rozier¹⁹¹⁵ in 1772. Delamétherie published Pictet's ideas there, although he misinterpreted and misunderstood Pictet's results, so that he believed that the cooling can be enhanced by adding smaller amounts of water to the vacuumed vessel. Like Chaptal, Delamétherie believed that an adiabatic cooling was a phenomenon the evaporation of the ether; but he failed and did not consider Pictet's assumptions. Delamétherie was a descendant of an important French family from La Clayette of eastern France, and he took over the chair of natural science at the Parisian French College in 1800.

Delamétherie's mistake was repaired by the mining inspector Arsène Nicolas Baillet, who taught at a mining school in Paris. In two parallel reports, Baillet realized and recognized the significance of Pictet's discovery and linked it with the descriptions of the mine pump in Schemnitz, today's Banská Štiavnica. He accepted Adair Crawford's¹⁹¹⁶ (* 1749; † 1795) assumption of increasing gas capacity by reducing its density.

A young German poet and novelist Ludwig Achim von Arnheim (* 1781; † 1831),¹⁹¹⁷ summed up the achievements as a student of mathematics in Göttingen. He advanced his ideas by the research of his predecessors on the expansion of gases into a vacuum. The former priest and the Jacobine Jacques Michel Coupé tried to explain adiabatic phenomena of recent sudden frosts and fires in France, much like Darwin before him; the global cooling/warming is therefore not just a flurry of today. Mollet (* 1756; † 1829)¹⁹¹⁸ from Aix, a professor of physics at central schools, later at the

¹⁹⁰⁸ Solovjev, 1983, 399; Lind, 1992, 318, 364–365, 375 Zois ordered Korn to buy four volumes of Kant's works published in Leipzig in 1796-1798, but never accepted Trubar and Kopitar's term Slovenian instead of his bellowed Carantania, Carniola or Wendi (Svoljšak, Vidmar, 2019, 65, 91).

¹⁹⁰⁹ Christoph Girtanner (* 1760; † 1800 (Paušek-Baždar, 1994, 26)).

¹⁹¹⁰ Jean Antoine Claude Chaptal count de Chanteloup (* 4. 6. 1756, Nogaret; † 30. 7. 1832, Paris).

¹⁹¹¹ Fox, 1971, 49, 79.

¹⁹¹² Marc Auguste Pictet (* 1752; † 1825).

¹⁹¹³ Fox, 1971, 51.

¹⁹¹⁴ Benjamin Thomson count Rumford (* 1758; † 1814).

¹⁹¹⁵ Abbé François Rozier (* 24. 1. 1734 Lyon; † 29. 9. 1793 Lyon).

¹⁹¹⁶ Adair Crawford (1749; † 1795).

¹⁹¹⁷ Ludwig Achim von Arnim (1781; † 1831).

¹⁹¹⁸ Joseph Mollet (1756; † 1829).

university in Lyon, has rarely quoted Coupé's research. The French were not much interested in adiabatic phenomena until Laplace and Biot used it to obtain the important physical results by calculating velocity of sound in the air in 1802.¹⁹¹⁹

Dalton¹⁹²⁰ with his precise experiments, again unveiled the entire Pictet's problem. According to the principles of Black's student Glasgow professor Irvine,¹⁹²¹ supplemented with the theory of caloric, Dalton explained the higher temperature in the empty space by the greater specific heat of the vacuum which seemingly dwarfed the specific heat of the same volume of air. That presumption was refuted by the incorrect measurements of Delaroche¹⁹²² and Bérard¹⁹²³ in 1812, which was mistakenly awarded by the Parisian Academy.¹⁹²⁴ Their error was investigated by the research of specific heats of the Poljane native Simon Šubic, who was the first among Slovenes to publish about the dangers of explosion of steam boilers. Šubic learned about that problem already at home, since the first steamer in the Slovene ethnic territory had been tried in Trieste in 1818, and a dozen years later, the Bohemian German Josef Ressel (* 1793; † 1857) experimented with a screw locomotion to amuse the folks in Trieste.

15.9.3 *Specific Heat of the Caloric Theory*

The specific heat is more difficult to measure in gases than in droplets of fluids or in solids. The first major measurements were published by Crawford in 1779 and 1783. He exhausted one of his brass vessels, and in the other he left air. The containers were heated and immersed in the same calorimeter. He measured the temperature of the calorimeter and thus determined the specific heat of the air at a constant volume. The result was only 3% higher than the modern one. However, the brass container had a much larger mass than the measured gas, so the accuracy of the measurement was not high.¹⁹²⁵

So, Crawford's measurements were not taken seriously until Dalton analyzed them in 1808 and 1842. Dalton combined Irvin's theory of the proportionality between specific heat and the heat contained in body with Dalton's own theory of caloric, which was otherwise foreign to both Irvine and Crawford's way of thinking¹⁹²⁶ because Irvine was more an industrial chemist and owner of glassworks far from Dalton's theoretical speculations. Crawford considered that his measurements confirmed Irvine's theory published by Irvine's son also named William (1776-1811).

The ice calorimeter was assembled by Lavoisier¹⁹²⁷ and Laplace in winter 1782/83 and they equipped it with instructions for determining the specific heat of the gases. Their measurement of specific heat of air at constant pressure exceeds the modern value by 36%.

Crawford, Lavoisier and Laplace did not distinguish specific heat at a constant pressure from that at a constant volume at the end of the eighteenth century. In the last years of the first empire, the French researchers have already known the difference. They were especially interested in the influence of specific heat on the speed of sound. Hence the prize of the French National Institute, which in January 1811 promised 3000 francs for:¹⁹²⁸

"The determination of specific heat of gases, especially oxygen, nitrogen and some composite gases, and comparison with the specific heat of water(...)"

The prize was to be awarded in 1813. Two important discussions were submitted. Clément¹⁹²⁹ and his later father-in-law Désormes¹⁹³⁰ were not rewarded (because they failed to compare their results with specific heat of the water. In their paper, published only in 1819, they complained as victims of a certain scientific policy, which was not far from true situation during the reign of Laplacian school. However, they had a factory in Verberie in Oise department 79 km north of Paris

¹⁹¹⁹ Fox, 1971, 52, 79-81.

¹⁹²⁰ John Dalton (1766; † 1844).

¹⁹²¹ William Irvine (1743; † 1787).

¹⁹²² François Delaroche (1781; † 1813).

¹⁹²³ Jacques Etienne Bérard (1789; † 1869).

¹⁹²⁴ Fox, 1968, 191, 196; Kuhn, 1958, 134-135.

¹⁹²⁵ Mach 1919, 195; Finn 1964, 11.

¹⁹²⁶ Fox 1968, 192, 196-197.

¹⁹²⁷ Antoine Laurent Lavoisier (* 1743; † 1794).

¹⁹²⁸ Fox, 1968, 201; Finn, 1964, 11; Lavoisier, Laplace, 1982, XVI, 39.

¹⁹²⁹ Nicholas Clément (Clément- Désormes after his marriage in 1820, * 1779 Dijon; † 1841 Paris).

¹⁹³⁰ Charles-Bernard Désormes (1777 Dijon ; † 1862 Verberie).

and a teaching posts in Paris, so they were not really threatened up with any hunger by their unjust compatriots.

In fact, Clément and Désormes' measurements contradicted the fundamental principles of Gay-Lussac's¹⁹³¹ work in recent years; of course, this could not have been without consequences. Instead of the assumptions of the Laplacian Circle advocated Dalton's Irvinist theory and opposed its later victorious rivals of Delaroche and Bérard whose father worked with Chaptal.¹⁹³² The inclinations of both couples were different because Delaroche and Bérard were more naturalized Parisians and more involved in biological researches. Clément and Désormes' closed the container full of air associated with the water gauge and the vacuum pump. They reduced the pressure in their container by about one centimeter of the mercury column, that is, to 0.987 Pa. They briefly opened their valve so that the outer and inner pressures were offset. Then they shut their valve. The closed gas gradually lost heat. The gauge measured the pressure drop of the locked gas, which determined the increase in temperature during the opening of the valve.

In the second part of Delaroche and Bérard's experiment, the gas bottle was poured into the calorimeter so that the gas was stretched towards the water gauge. The elongation measured the specific heat of the gas at constant pressure. With a slightly modified process, the relative specific heat can be measured at three different pressures lower than the normal pressure.

From the first experiment, Clément and Désormes could calculate specific heat at a constant volume. If T_2 is the outside temperature, T_1 is the temperature of the vessel after they closed their valve and the pressure equalized with atmospheric pressure p_1 ,

$$T_1 = (C / c) T_2$$

If the final pressure p_3 is measured with the gauge, the ideal gas equation applies:

$$p_1 - p_3 = (R \rho / M) (T_1 - T_2)$$

$$C - c = R/M$$

¹⁹³¹ Joseph Louis Gay-Lussac (* 1778; † 1850).

¹⁹³² Fox, 1971, 138, 150. Jacques Étienne Bérard (* 12. 10. 1789 Montpellier; † 1869).

$$c = (\rho T_2) (R/M)^2 / (p_1 - p_3)$$

Thus, Clément and Désormes measured the specific heat at a constant volume and at constant pressure. In this too they differed from Delaroche (1813), for whom, Crawford's specific heat did not seem to be "a specific heat in the sense as it is (usually) given to this word in a constant volume, since such closed gases cannot expand, note-could they liquefy".¹⁹³³ Half a century later, the approach was completely changed since Clausius¹⁹³⁴ had specific heat at a constant volume (c) for the "wahre (Wärmecapacitat)" therefore for the real one.

The award was given to Delaroche and Bérard for their measurements of specific heat from 1812 published the following year. Their results contradicted Irvin's theory, much like Dulong¹⁹³⁵ and Petit's¹⁹³⁶ findings on the inverse proportionality of specific heats and atomic masses of metals from 1819. Similarly as Delaroche and Bérard, also the other couple Dulong and Petit stated that the measurements do not confirm the proportionality between changes in specific heat and the absorption or emission of heat during chemical reactions.

Then, the specific heat, of course, is not proportional to the heat contained, as predicted by Irvin's theory in the Dalton version, which was based on caloric. Both caloric theories, Dalton's Irvinist and Delaroche-Bérard's, also had common points. Both predicted that the vacuum had a higher specific heat than the air of the same volume. Delaroche and Bérard explained the results of their measurements by decreasing the specific heat by lowering the pressure, as the caloric easier penetrated an empty space.¹⁹³⁷

Until the measurements of Regnault¹⁹³⁸ published in 1853 and later, the claims of Delaroche and Bérard specified the mainstream reflections on the specific heat of the gases. The misinterpretation of their results thus led astray a whole generation of researchers.

¹⁹³³ Finn, 1964, 12.

¹⁹³⁴ Clausius 1862, reprint 1864, 278.

¹⁹³⁵ Pierre Louis Dulong (* 1785; † 1838).

¹⁹³⁶ Alexis Thérèse Petit (* 1791; † 1820).

¹⁹³⁷ Dalton's note in diary on June 1800; Fox, 1968, 191.

¹⁹³⁸ Henri Victor Regnault (* 1810; † 1878).

Table 15-11: Significant early measurements of specific heat in kcal / (kg K):

Authors	Year of measurement	Year of publ.	Measurement instrument	Measured specific heat	Investigated gas	Results for air	Used in theory
Crawford		1779, 1788	closed containers immersed in calorimeter	c	Air	0.179	Dalton 1808
Lavoisier in Laplace		1783	Ice calorimeter	C	Air	0.33	
Dalton		1808, 1842	Same as Crawford				
Delaroche & Bérard	1812	1813	flow calorimeter	C	Various	0.267	Laplace 1816 C/c = 1,5
Clément & Desormes	1812	1819	Adiabatic Stretching	C in c	Various		Poisson 1823
Gay-Lussac in Welter		1822	Unpublished	C/c	Air	1.3748	Laplace 1823
Regnault		1853, 1862	flow calorimeter	C	Various	0.2377	Clausius 1862
Contemporary results						C=0.2420 c = 0.173	

Let's look at the more details of measurements of Delaroche and Bérard. The modern reader should note that the number of published decimal places in their results greatly exceeds the accuracy of their measurements. This was exactly in line with the then practices in physics, but today, of course, it sounds very strange.

In the Delaroche and Bérard device designed as a flowmeter, a constant mass flow of gas with constant pressure and temperature T_1 in a calorimeter was flowed through the tube and drained with temperature T_2 . In addition, the calorimeter was heated from the temperature T_3 to the temperature T_4 . We get:

$$m_g \cdot c_g \cdot (T_1 - T_2) = m_a \cdot c_a \cdot (T_4 - T_3)$$

Index g refers to gas, while index a designs water in the calorimeter.¹⁹³⁹ According to this equation, the specific heat of a gas at a constant pressure (c_g) was determined. Delaroche and Bérard investigated the specific heat dependence of the gas density. They prepared the experiment so that the air could run into a calorimeter at two different pressures. The first measured 0.974 bar, while the other measured 1.322 bar. They only published two measurements; for both, the specific heat at a higher pressure was greater in the ratios 1: 1.2127 and 1: 1.2665. Since the pressure is in the ratio 1: 1.357, the gas must have a smaller specific heat at a higher pressure. The specific heat was reduced by a ratio of 1: 0.913 with a pressure increase.

The result of Delaroche and Bérard differs by less than 10% from modern measurements. Today at

¹⁹³⁹ Mach, 1919, 196.

such a small pressure interval we expect a barely perceptible decrease in the specific heat of the gas. The error was not great, but it had fatal consequences. The result of Delaroché and Bérard was in line with the expectations of the then theory that the compression of a substance hinders the penetration of the caloric into the space between molecules. This theory was also advocated by the leading French researcher Laplace, who used the wrong results of Delaroché and Bérard in his theory of the speed of sound in 1816. The Laplacian theories were extremely influential and, according to his predictions, they even adjusted the results of the measurements, just like in the modern climate change hoaxes.

The Parisian Institute's prize was such an important decoration that the Delaroché and Bérard's measurements were not seriously examined for more than three decades, although other theories and experiments offered completely opposite conclusions about the nature of specific heats of gases.

The results of Delaroché and Bérard contradicted the theory of the Poisson,¹⁹⁴⁰ velocity of sound determined in 1808 and measurements of the ratios between the specific heats of Gay-Lussac and Welter. Gay-Lussac and Welter¹⁹⁴¹ did not publish details of their technique of measurements in 1822, but they probably resembled the ideas of Clément and Desormes. Their results were used by Laplace in 1823 in his new theory of sound.

The results of Delaroché and Bérard were kept afloat even longer than the caloric theory that did not survive the middle of the 19th century. They were the basis for many theoretical considerations. Even in 1816 in Paris Biot was convinced that the previous measurements were not precise enough to establish a convincing theory about the ratio between the specific heats of the gaseous compound and its components ("dei gaz componenti e gaz composto").¹⁹⁴²

In 1816 and 1817, the Torino professor Avogadro¹⁹⁴³ in Milan published such a theory. He analyzed the measurements of the specific heat of

the various gases published by Delaroché and Bérard in addition to the described measurement.

Despite of the large deviations in some cases, Avogadro believed in the validity of the equation:

$$(c)^2 = \sum p_i \cdot (c_i)^2$$

where we would now write the Avogadro's symbol c used for "calore specifico riferito al volume" as:

$$c = c_p \cdot \rho / (c_p(\text{air}) \cdot \rho(\text{air}))$$

The quantities with the index "i" refer to the components of the compound, and the weights p_i are the relative volume proportions or the relative number of molecules of the individual elements. Thus, for carbon monoxide CO, which forms carbon dioxide CO₂ with oxygen O₂, it would be:

$$(c \cdot \rho \cdot (\text{CO}))^2 + (1/2) \cdot (c \cdot \rho \cdot (\text{O}_2))^2 = (c \cdot \rho \cdot (\text{CO}_2))^2$$

A similar equation was written by Dulong in 1830.¹⁹⁴⁴ The modern measurements show that in the case of carbon dioxide the sum on the left is 20% smaller than the right side of the equation. With the Avogadro equation for specific carbon dioxide we get the following results:

$$(cd(\text{CO}))^2 + (1/2)(cd(\text{O}))^2 = 1.3 \cdot 10^6 \text{ (J / (K}^3 \text{ m}^2))$$

$$(cd(\text{CO}_2))^2 = 1,6 \cdot 10^6 \text{ (J/K}^3 \text{ m}^2)$$

Avogadro's affinity for caloric ("Affinita per calorico", a) for gases:

$$a = (c^2 / d)$$

where:

$$d = \rho / \rho(\text{air})$$

is even a more interesting one. From the written Avogadro's equations, it follows that the affinity for caloric in the compound is equal to the sum of the affinities of its components:

$$a_i = \sum a_i \cdot v_i$$

v_i are the weight proportions of the elements in the compound. A similar equation is used today, only

¹⁹⁴⁰ Denis Poisson (* 1781; † 1840).

¹⁹⁴¹ Jean Joseph Welter (* 1763; † 1852).

¹⁹⁴² Avogadro 1816/17, reprint 1911, 106.

¹⁹⁴³ Amedeo Avogadro (* 1776; † 1856).

¹⁹⁴⁴ Avogadro, 1911, CXV.

Avogadro's affinity for the caloric "a" should be replaced with specific heat. Avogadro wrote an equation that links the physical and chemical properties of gases:

$$c = (a \cdot d)^{1/2} = K \cdot (m \cdot a)^{1/2}$$

m is the mass of the molecule, and K is a constant. Avogadro's hypothesis from 1811 can be derived from the above assertions. In 1816/17 Avogadro did not deal with specific heat at a constant volume. They were not yet able to measure it directly, but it can be calculated from the velocity of sound according to Poisson and Laplace's theory. However, Dulong only published useful measurements for one-atomic gases; Avogadro used them in the third part of his most comprehensive *Fisica dei corpi imponderabili* in 1838.¹⁹⁴⁵

Even the famous Carnot¹⁹⁴⁶ was uncritical to the measurements of Delaroche and Bérard, although he was also influenced by their opponent Clément. Delaroche and Bérard's incorrectly measured dependence of the specific heat of the air on the pressure. In Carnot's later famous booklet, that error was extended to the pressures between 1/1024 and 1024 bar in 1824.¹⁹⁴⁷ According to Carnot, the specific heat of the air is reduced by as much as 11.5 times in this pressure interval! Only twenty years after the publication of Carnot's book Johann August Natterer (1821-1901) reached such high pressures! In April 1844, during his medical studies in Vienna, Natterer predicted that he would investigate gas pressures at a pressure of up to 2000 bar. In November 1850, Natterer described his first experiments at 1000 bar. There are so many pressures which Carnot discussed a quarter of a century too early in the year 1824. With the financial support of the Viennese Academy and with the participation of a correspondent member of the Academy elected on 1 February 1848, the zoologist and Doctor of Medicine Ludwig Redtenbacher born in Kirchhoff in 1814, Natterer already reached 3600 bars in 1851. Three years later, Natterer published accurate measurements of five different gases at pressures of up to 2790 bar, as also reported by Andrews. Ludwig Redtenbacher was the second cousin of researcher

of Dynamide Jacob Ferdinand Redtenbacher¹⁹⁴⁸ and a brother of Josef Redtenbacher (* 1810).¹⁹⁴⁹ Jacob began his research as an assistant to Arzberger, who studied running water and ships for mechanical engineering at the Viennese Polytechnic Institute.¹⁹⁵⁰

With the general recognition of the results of the measurements of Delaroche and Bérard, researchers gave a decisive blow to Irvin's theory. Dalton gave up Irvin's theory only in 1827, when he himself repeated the experiments of Delaroche and Bérard.¹⁹⁵¹ Both contradictory theories remained in the range of the preservation of caloric. In the early thermodynamics, the researchers finally rejected the caloric itself. The first experiments which tried to disprove the conservation of caloric were published by Count Rumford in 1781 and 1798 and by his protegee Davy.¹⁹⁵² Both were closely linked to the beginnings of the Royal Institution, which could have affected the related negative attitudes towards caloric intake of both researchers. They were Anglo-Saxons, while many basic facts about caloric belonged to the beheaded Frenchman Lavoisier.

In those times the term 'permanent' was used for the modern idea of 'ideal' gas. The scientists argued that oxygen, nitrogen, hydrogen and some other gases cannot be liquefied at all. The first doubts in Delaroche and Bérard's experiments did not appear until 1850, at the same time in ideas of three researchers: Joule, Rankin and Clausius. At the beginning of his experimenting, Dalton's disciple Joule¹⁹⁵³ came to the idea that heat can be expressed in units of work. But his experiments at

¹⁹⁴⁸ Jacob Ferdinand Redtenbacher (* 1809; † 1863).

¹⁹⁴⁹ Natterer, *Ann.Phys.* (1844) 62: 134; Natterer, *Wien.Ber.* (1850) 5: 356; Natterer, *Wien.Ber.* (1851) 6: 568; Natterer, *Wien.Ber.* (1854) 12: 202; Natterer, *Ann.Phys.* (1855) 94: 436. Thomas Andrews (* 1813; † 1885), 1869 (reprint 1889, 296).

¹⁹⁵⁰ Johann Arzberger (* 1778; † 1835 (Hantschk, 1988, 128)).

¹⁹⁵¹ Fox 1968, pp. 191 and 196. Dalton's record from June and the year 1800 (Fox, 1968, 191) describes the variant of Irvin's theory, according to which the vacuum should have a greater specific heat than the air of the same volume. This conclusion did not contradict Delaroche and Bérard's assumption that, by reducing air pressure, its specific heat increases, as the specific heat supposedly increases with volume.

¹⁹⁵² Humphry Davy (* 1778; † 1829).

¹⁹⁵³ James Prescott Joule (* 1818; † 1889).

¹⁹⁴⁵ Avogadro 1816/17, reprint 1911, 118; Dulong, 1829, 113; Morselli, 1984, 314-315.

¹⁹⁴⁶ Sadi Carnot (* 1796; † 1832).

¹⁹⁴⁷ Carnot, 1953, 63; Fox, 1971, 183-184.

first did not convince either William Thomson¹⁹⁵⁴ or Helmholtz, though both were inclined to relate to similar ideas.

Based on the vortex theory of molecular structure, the Scotsman Rankine¹⁹⁵⁵ conceived heat as the motion of material particles. Nevertheless, he refused to consider Joule's experimental results and calculated the mechanical equivalent of heat from the measurements of the specific heat of the air at constant pressure. He used the measurements of Delaroche and Bérard like Mayer¹⁹⁵⁶ did eight years before. Rankine's calculation of specific heat of air was in accordance with the measurements of the Regnault's Group, which were published three years later. Clausius made theoretical findings before the experiment in 1850. He argued that in the "permanent" gas both specific heats must be independent of the pressure and temperature in contrast to the measurements of Delaroche and Bérard.

As early as 1824 Carnot knew that the difference between the specific heat was constant. Poisson, Gay-Lussac and Welter have found that ratio of the specific heats is constant. In his theory, Clausius merely linked both findings.¹⁹⁵⁷

The last doubt disappeared with the measurements of the Regnault's Parisian group published in 1853. They used Delaroche and Bérard's measurement methods from 1812; but their result was completely different. The specific heat of the air remained constant at pressures between 1 and 7.465 bars. Regnault has proven that the specific heat of "permanent" gases does not change with temperature. It would, therefore, be very interesting to know how Laplace and colleagues would research within their theories of the caloric if someone half a century before Regnault tried to make a similar group of precise experiments to determine the properties of gases.¹⁹⁵⁸

According to the high-profile tests of the Regnault's group, it was shown that the increased pressure does not impede "penetrating heat into the substance". The research on heat rays has also

contributed to the abandonment of the theory of caloric.¹⁹⁵⁹ It was already known in Europe after William Herschel's experiments proved that the rays of heat had the properties of light in 1800.

When, in the early 1820s, wave theory became established in optics, many tried to expand it into the theory of heat.¹⁹⁶⁰ The heat was conceived as a kind of movement, which in the second half of the 19th century could be already based on the law on the conservation of energy. This law is at odds with the theory of caloric preservation, as it predicts the reduction of heat by the motion of visible bodies. The new theory of heat strengthened, while the old theory gave it its space.

The heat theory that gradually supplanted the theory of caloric is called thermodynamics. The name "Thermodynamik" was first used by the later president of the Viennese Academy, Baumgartner, in a book published for the first time in 1837.¹⁹⁶¹ The new name became soon known on Habsburgian soil, because Baumgartner's book was used as a textbook of physics at gymnasiums in Ljubljana and Klagenfurt even in the 1860s. The term "thermodynamics" was adopted by W. Thomson in 1851.

By the analogy with optics, the wave theory of heat was able to pass from the theory of caloric to modern theories. It alone did not offer a convincing model of forces and particles of matter with which it could replace caloric. For this reason, the idea of moving and mutually colliding particles of matter has gradually become established.

The idea was by no means new. Daniel Bernoulli (1700-1782) described in 1738 the theory of motion of molecules of matter as the only acceptable theory of heat.¹⁹⁶² For the researchers such as Lavoisier and Laplace in 1783¹⁹⁶³ and Lamé¹⁹⁶⁴ in his textbook of 1836, this description equalled importance of the theory of caloric.

The kinetic theory in modern terms became a valid physical theory only after Krönig's paper in 1856 and Clausius' publication a year later. The first

¹⁹⁵⁴ William Thomson (* 1824; † 1907, after the year 1892 Lord Kelvin).

¹⁹⁵⁵ William John Macquorn Rankine (* 1820; † 1872).

¹⁹⁵⁶ Julius Robert Mayer (* 1814; † 1878).

¹⁹⁵⁷ Truesdell 1980, 274.

¹⁹⁵⁸ Fox, 1971, 298-299.

¹⁹⁵⁹ Thermal rays are now called infrared light waves.

¹⁹⁶⁰ Brush 1976, 303.

¹⁹⁶¹ Brush 1976, 322; Kangro 1976, 229.

¹⁹⁶² Vdovičenko 1985, 256-257.

¹⁹⁶³ Lavoisier and Laplace 1783, 5-6.

¹⁹⁶⁴ Gabriel Lamé (* 1795; † 1870).

researchers of the new theory, including Poljane native S. Šubic,¹⁹⁶⁵ were mainly focused on gases as a model for both other two aggregate states.

15.9.4 Joule-Thomson Cooling

K. Hell's and R. Gruber's early experiments were developed by the Brits, the French and the Germans. In Britain, they were first complemented by Cullen and Darwin, followed by Dalton, Joule, Thomson, Dewar,¹⁹⁶⁶ and finally Linde.¹⁹⁶⁷ In France, Jars reported on Hell's experiment, and then, as Leslie's critique, Humboldt and Gay-Lussac continued to research, and finally there was a good old sceptic positivist E. Mach.

Four decades after Dalton, his study of adiabatic phenomena was supplemented by his disciple Joule, a brewer from Manchester. By the time of his bankruptcy in 1854, Joule was the third generation of brewers, and his father had to set up his laboratory next to the factory. In 1843 Joule began to explore the expansion of gas in a closed system. The pressed gas adiabatically flowed from its vessel through the valve into the second empty tank. Joule described the experiment as the expansion of air into a vacuum without work and without any added heat. Internal energy and temperature remained unchanged.

In 1844, Joule knew Cullen, Darwin and Dalton's work, but Gay-Lussac's¹⁹⁶⁸ experiments at Bertholet's Arcueil Laboratories (1801) remained hidden to Joule, who therefore repeated them. Gay-Lussac encouraged Leslie's wrong assumption that all gases had the same thermal capacity; this was the time when erudite Europeans barely started to distinguish individual gases from each other. The ancient term air as the designation of all gases was only slowly abandoned after it became clear that the air itself is a conglomerate of several gases. Gay-Lussac used two bronze containers of capacity of 12 l and two apertures. His thermometer precisely showed up the temperatures up to a hundred degrees Celsius. At first, Gay-Lussac used a thermometer according to the ideas of Rumford and Leslie, and later arranged a less sensitive thermometer filled by alcohol. He concluded that,

in the case of a better vacuum, more heat is released from the intrusion of the surrounding gas. Therefore, he wanted to find the connection between the heat absorbed in one container and the heat freed in another vessel. He was also interested in the dependence of temperature differences on the density of the air. He proved that the lighter hydrogen spreads faster into vacuum than other gases.¹⁹⁶⁹

Joule attributed first quantitative experiments to his teacher Dalton's expansion of gases into a vacuum; with them Dalton supposedly denied the material nature of heat.¹⁹⁷⁰ In 1853, Thomson watched the penetration of air through silk. They used a double piston compression pump, a cylindrical piston with radius 4.5 inches, and its working stroke length of 9 inches. At sixty full strokes per minute, the pump can remove about 16,000 cubic inches of air every 16 minutes. Due to the mechanical piston, the losses caused by leakage were of course large; so, they never used more than half of the available power.¹⁹⁷¹

The present researchers today know those events as Joule's or free expansion. Joule attracted the Scotsman W. Thomson to more exact experiments in the open system; together they studied Joule-Thomson's cooling. However, it could not be clarified until the Irishman Andrews and the Dutchman van der Waals¹⁹⁷² reported that gas propagation is being carried out against attractive forces between molecules. Therefore, the temperature changes.¹⁹⁷³

The cooling by the expansion into the empty space was also studied by Ježica native Karel Robida.¹⁹⁷⁴ His example used to illustrate the mixing of two gases was resembling the attackers, who were shooting the crew of the fortress. In the Joule-Thomson experiment, gases cool when propagated into an empty space. Therefore, there is certainly an attractive force between the gas particles which decreases and cools the gas by increasing the distance between particles.

¹⁹⁶⁵ Simon Šubic (* 1830; † 1903).

¹⁹⁶⁶ James Dewar (* 1842; † 1923).

¹⁹⁶⁷ Karl Paul Gottfried von Linde (* 1842; † 1934).

¹⁹⁶⁸ Louis Joseph Gay-Lussac (* 6. 12. 1778 St. Léonard in Limousin; † 9. 5. 1850 Paris).

¹⁹⁶⁹ Ames, 1898, 4, 6, 12.

¹⁹⁷⁰ Ames, 1898, 29.

¹⁹⁷¹ Ames, 1898, 41, 88.

¹⁹⁷² Johannes Diderik van der Waals (* 1837; † 1923).

¹⁹⁷³ Mendelssohn, 1977, 47-48; Ayber, 1965, 5.

¹⁹⁷⁴ Robida, 1865, 231.

Most gases are cooled at normal temperatures while expanding into an empty space. Some heat up, including hydrogen and helium. Adiabatic cooling of gases with the expansion into an empty space became useful only with Faraday's condensation plan for all gases; even those gases which until then were considered permanent. It turned out that the propagation of gas into an empty space is the most appropriate procedure for its cooling. It was used for the liquefaction of air, hydrogen and helium in the last quarter of the 19th century. Today it is used in all domestic compressor-type refrigerators. It is also interesting for exploring the microscopic properties of real gases. In all these modern technologies, we see the consequences of experiments of Tobias Gruber.

15.9.5 Conclusion

The brothers Gabriel and Tobias Gruber were among the leading researchers in the Habsburg Monarchy. They also left their seals on the investigations of the cooling of gases while propagating in a vacuum. They discussed and even quarreled with the most important contemporaries, pulled out sometimes with the right and second time again with the wrong side and thus celebrated Habsburg or even the Carniolan physics far beyond Carniolan geographical borders.

The measurements of Delaroche and Bérard used to be the example of experimentalists misled by the theorists. As the fatal consequence, those experimentalists misled the next generation of the theorists and so on, until the changed opinion of theorists demand more money for the more accurate experiments which, as was expected, proved the initial experimental error of the Genevan physician-botanist turned Parisian Delaroche (François-Étienne de La Roche) and Bérard attached to the Laplacian Berthollet's Société d'Arcueil. The process ramped almost a half of a century! Who is to blame for the misleading misinterpreted facts? Hardly anybody. We are all and we always were the victim of the propaganda in media which tells us what is right and what is wrong and even what to buy and what to abandon. The top mainstream scientists are just the humans and therefore victims of the same politics which they themselves help to establish. The victory of Laplacian Napoleonic caloric theory over the Jesuitical Ancien Régime Stahl's

phlogiston was abolished after the spring of nations of 1848.

15.10 Vacuum Becomes Part of the Electrical Industry

15.10.1 Vacuum Devices of the First Professor of Physics in Slovenia, Who was not a Member of the Monastic Order (on the 250th Birthday of Neumann)

The Parisian revolutionary battles which guillotined Maria Theresé's daughter quickly affected the Viennese, while the peripheral Ljubljana ex-Jesuitical experts enjoyed some delays. The era of Gruber and the Jesuits of Ljubljana completely ended only after the arrival of Johann Philipp Neumann (* 27 December 1774, Třebíč (Trebitsch, Trebiž), north of Vienna, west of Brno in Moravia, † 1849, Vienna). He came in Ljubljana immediately after completing his studies at the Viennese Law School. Despite his early interest in vacuum techniques, he could not immediately take over the Department of Physics in Ljubljana. His legal were not surprising, since the choice was then reduced to the studies of theology, law and medicine. First, he taught Greek language in Ljubljana for two years instead of John Nepomuk Morack (Morak, Morach, * 2 September 1730/31, Ljubljana; SJ 28. 10. 1748; † 9. 1. 1807, Radomlje) until the illness and death of Ljubljana physicist Jernej Schaller (* 24. 8. 1745; † 29. 4. 1803, Ljubljana) opened Neumann's way to the desired department. Neumann then lectured for a few months as a substitute professor of physics and edited a rich collection of three hundred and nine vacuum and related devices left by Schaller and the mathematician Anton Gruber.¹⁹⁷⁵ With his demanding repairs for the maintenance of many vacuum pumps, Musschenbrock valves and Magdeburg hemispheres, the notorious Neumann's talent for the order was already revealed, which was later upgraded with three decades of his librarian's work at the Viennese Polytechnic. The

¹⁹⁷⁵ ZAL LJU 184/1, box 52, fasc. 179, *Verzeichnis. Der in physikalischen Saale verfindigen physischen, und mathematischen, und anderen verschiedenen Geräthschaften (=Geräthschaften, tools)*, ten bind unpagged folios A3, dated on the bottom of the last page.

editing of their library was already accomplished by his senior manager, Franc Wilde, who was also the first to be concerned about the progress of vacuum techniques and related disciplines of those days. In doing so, Neumann was helped by his knowledge of many languages: Latin, Greek, German, French and Italian. He also knew some Slavic languages, including, of course, the Czech language of his homeland.¹⁹⁷⁶



Figure 15-56: Last Schaller's signature under J. K. Kersnik's assessment of students of physics and mathematics; in the latter, Schaller replaced the resigned Anton Gruber. The document was given by Wilde's directorship on 6 April 1803, three weeks before Schaller's death (ZAL SI LJU 184/1, box 75, p. 453).

physics, signed on 21 December 1805 by F. Wilde (ZAL SI LJU 184/1, box 79 fasc. 470)

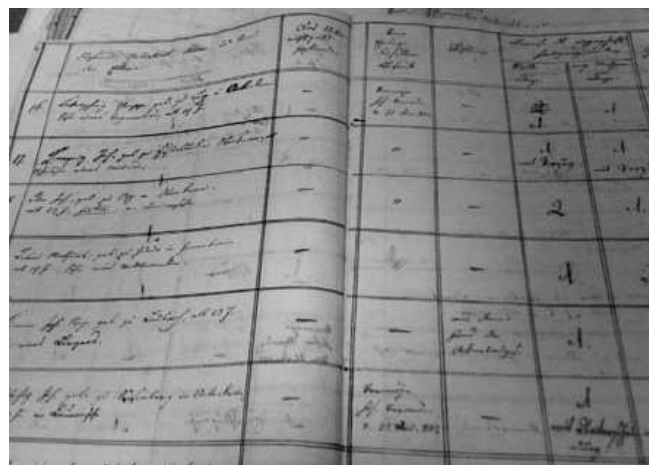

Figure 15-58: On 28 August 1803, Neumann and M. Kalister assessed the future professor of physics JK Kersnik with the highest marks in physics and mathematics in his second semester of physics and applied mathematics (ZAL SI LJU 184/1, box 75, Fasc. 453).

15.10.2 Neumann's Ljubljana Predecessors

With the death of Jernej Schaller, nearly exactly one hundred years of Jesuit physics in Ljubljana ended. After A. Gruber's sudden departure, Schaller also took over the teaching of mathematics for some time. The gradebooks of Schaller, Wilde and A. Gruber's Ljubljana students of physics with chemistry, philosophy and mathematics are preserved. The lists include tables with the student's names, places of birth, ages, grades in physics and mathematics and overall learning success. Documents were usually signed by the professor of physics, the professor of mathematics and by Franz Wilde as director. On 15 July 1791, Gruber and Schaller had twenty students; among the eight listed on the first page was also the later professor of Ljubljana, then seventeen-year-old Franc Hladnik from Idrija. On the other second page, another twelve students were enumerated. The list was authenticated by Wilde as a teacher of philosophy on 22 July 1791. The first two guys noted among the students of the philosophy and physics were the Counts Turjaški (Auersperg), Karl and Josef from Ljubljana. They were 17 and 16 years old. Both had a Tertiary scholarship (Stiftung). They did not get grades from chemistry-physics, while they had the best grades (mark one of those times) in philosophy and

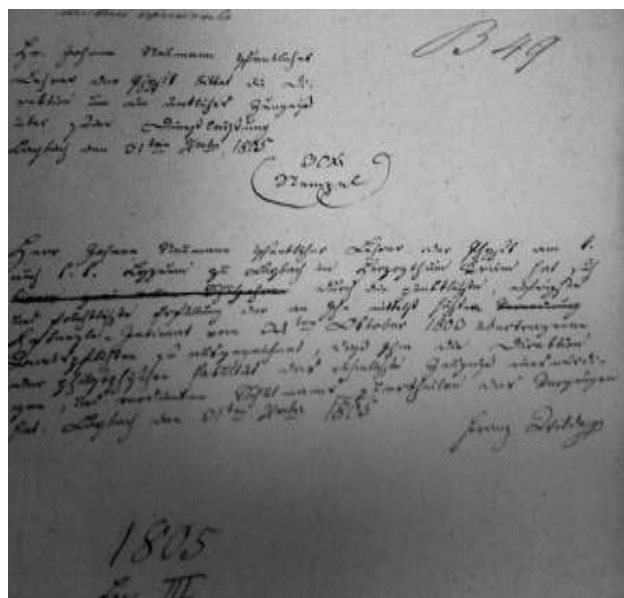

Figure 15-57: Neumann's application for the official certificate of the Ljubljana professor of

¹⁹⁷⁶ ZAL SI LJU 184/1, box 52, fasc. 166, lists of professors dated on 8. 2. 1804 and 11. 11. 1806. Morack lectured on 8 September 1801, on 24 December 1801, the chair was formally vacant, although Neumann lectured on July 21, 1801; at least he already took it over officially on 8. 9. 1802.

elementary mathematics. In third place, the Lower Carniolan (Dolenjec) Leopold Baumgartner of Poganjice got his mark in physics; Johan Count Brigido, born in Lvov of then Habsburg Polish

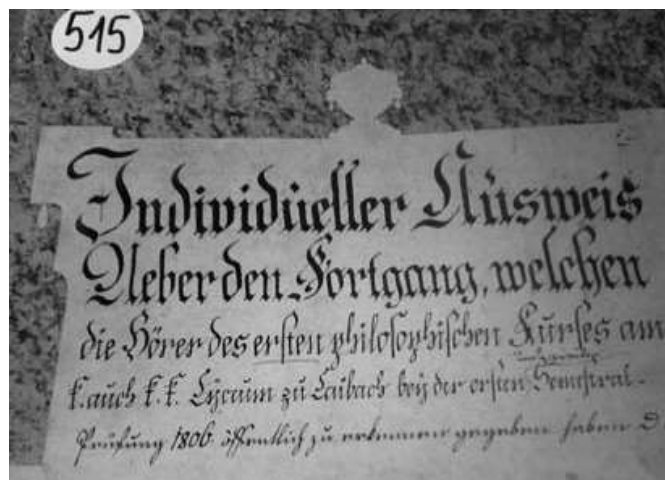

Figure 15-59: The title page of the regular textbooks for students of the first philosophical course in physics as the main subject in the first and second semesters dated 20 September 1806 (ZAL SI LJU 184/1, box 86 fascicle 515)

Figure 15-60: Last Neumann's Ljubljana signature under physics and Greek language grades of his students in a gradebook dated on 20 September 1806. Those students attended the first philosophical course in the first and second semesters. To the left of Neumann is the signature of mathematician J. Jenko, who also evaluated the students of general history (ZAL SI LJU 184/1, box 86 fasc. 515).

Galicia, was also listed in physics class,¹⁹⁷⁷ while the note was signed by Wilde on 6 September

¹⁹⁷⁷ *Hat Gezählt* (ZAL SI LJU 184/1, , box 75, fasc. 451, *Ausweis den wissenschaftlichen Vorgang ...*16.–25. 8. 1792).

1792. Similarly, it was also with students of mathematics¹⁹⁷⁸ where both counts Auersperg had also the highest marks “one” in geometry and trigonometry. Anton Gruber signed the document on 27 August 1792. This was followed by a list of the students of trade school (Krämer) in Ljubljana in 1789/90. In the days from 16 to 24 August 1792, the professors compiled another gradebook filled with marks for the students of physics in Ljubljana. Peter Garzarolli (von Thurnlackh, * 25 June 1774 Trieste; † 1846, Trieste) was noted on the first place as the eighteen years old teenager. He became a city physicist in Trieste in 1819. He was followed by a 17-year-old Leopold Count Hohenwart. The document was signed by Schaller on 27 August 1791. A. Gruber signed the marks of sixteen students of mathematics on August 27, 1792 designed three days earlier on August 24, 1792. On 6 September 1792, the gradebooks for Garzarolli, Hohenwart and their classmates were signed by the student of theology, Josef Matija Robič, who was employed as a magister repeater on the specialization.¹⁹⁷⁹ Robič was born around 1770.

On March 28, 1801, Georg Jonke (* 1777, Gorenje (Obern) No. 4; † 1864) from Kočevje was enrolled among the students. Their gradebook was signed by Schaller and A. Gruber; Jonke later became an established beekeeper, the Črmošnjice parish priest and a local mayor during the French Illyrian provinces. A. Gruber has last signed under the curriculum of gradebook with marks on 20 April 1802 and 24 August 1802. On 6 April 1802, Schaller signed as a professor of physics and a substitute (suplent) teacher of applied mathematics, and on August 27, 1803, under the gradebook full of marks Wilde and Matthias Kallister signed; the latter as a teacher of the 4th (grade) of Normal Elementary school and substitute (suplent) teacher of mathematics at Lyceum. On May 29, 1804, Josef Jenko was signed as a teacher of mathematics. On the same day, on 6 April 1804, and again in October 1804 Johan Neumann signed as a teacher of physics with chemistry, and a lecturer in Greek literature and grammar.¹⁹⁸⁰ Jenko

¹⁹⁷⁸ 16.–24. 8. 1792 in listing entitled *Ab geheilte 2^{ten}zum. ...*

¹⁹⁷⁹ ZAL SI LJU 184/1, box 75, fasc. 451 (catalogue 1791). Fasc. 452 has marks for dates between 16. 3. 1796 and 25. 8. 1800.

¹⁹⁸⁰ ZAL SI LJU 184/1, box 75 (catalogues 1791–1806, 1811), fasc. 453 (catalogues 1801–1804).

and Neumann lectured together in Graz again a decade later.

The repair of models and machines for physics with chemistry lessons was listed on 16 June 1800. Under no. 4638 Zollmann described a new mechanical school on 26 July 1800.¹⁹⁸¹ On 13. 4. 1802 under the number 88/12 Wilde signed the act for the re-establishment of the Ljubljana Mechanical School; he described the lectures of mechanics and statics, and the additional work of the adjunct professor. On November 2, 1802 under number 262, in red color marked as B 22, Wilde signed the material for the school session designed for the provisional corollary supplement of the lectures of dogmatic by Matija Ravnikar and of mathematics by Matija Kalister was the library penman (scribe). The full professor of physics (Schaller) coordinated the lesson of the mathematics of the less experienced substitute professor Kalister's curricula. Anton Gruber terminated his lectures between 24 August 1802, when he was signed for his last time, and 2 November 1802, when Kalister was already mentioned as a substitute (suplent) teacher.

On 27 October 1802, under the number K 144, eighteen years old captain-Hauptmann's son Joseph Safshman, a student at St. Julius, probably at Julius-Maximilians-Universität Würzburg which recently abandoned its strict Catholicism, applied for the competition for the professor of mathematics in Ljubljana. He mastered the Latin and Slavic languages, and he had five classes of gymnasium teachings behind him. On 6 November 1802, under no. 6483 the priest Matija Kalister was listed as the substitute (suplent) teacher of dogmatic (sic!) and a mathematician while he signed himself as a physicist.¹⁹⁸² The mishmash of titles testified about the troubled era of Ljubljana school in those days. On 30 April 1803, Wilde reported Schaller's death, which occurred on the previous evening at half past eight due to severe fever as a side effect of rheumatism.¹⁹⁸³

15.10.3 Ljubljana Physics

The long-standing Neumann's wish was fulfilled by his takeover of the department of physics and

¹⁹⁸¹ ZAL SILJU 184/1, box 78, fasc. 464.

¹⁹⁸² *der ungewandte Priester der wirkliche Lehrer der Physik* (ZAL SILJU 184/1, box 78, fasc. 466).

¹⁹⁸³ *Gestern Abend... an eine Schlecht Fieber mit Rheumatische Seitenstecken.*

cabinet of physics, full of popular vacuum devices. Of course, everything did not go smoothly and quickly. Prior to the official take-up of that chair, Neumann had to pass through a long exam proving his knowledge about characteristics of bodies, free fall, Archimedean law and colors of bodies that are not transparent. For the additional point, the exam continued with a written work on the correct installation of the lightning rods, and the advantages of Copernican astronomy based on the interplanetary vacuum. The exam questions did, of course, sound somewhat outdated to contemporaries as they were compiled by a friend of former professor Gabriel Gruber and his brother Tobias, Joseph Walcher (* 6. 1. 1718, Linz; SJ 18. 10. 1737; † 29. 11. 1803, Vienna). Walcher had advanced age at that time; he was more than half a century older than the only candidate Neumann who, of course, won the competition after his successful exam.

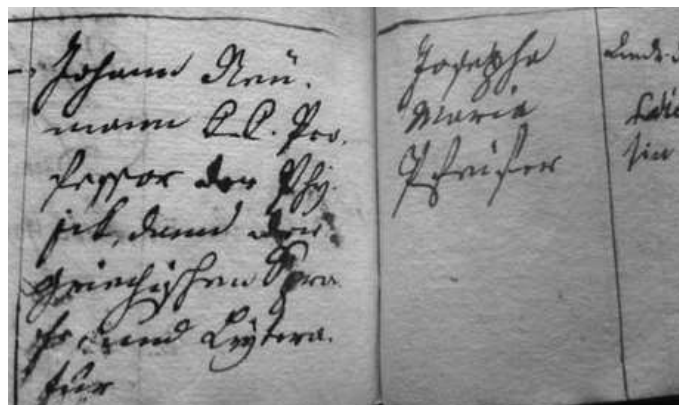

Figure 15-61: A record of Neumann and his wife Josepha Maria born Pfeifer at the baptism of their son the future physicist August Emanuel Neumann in the Ljubljana cathedral on September 27, 1804 (NŠAL Baptism Book of St. Nicholas Ljubljana, p. 28)

15.10.4 Graz and Vienna

Neumann's lessons in Ljubljana lasted only five years, since he signed the last certificates in August 1806 after he has already received proof of his Ljubljana service years during the previous years. Thus, in the autumn of 1806, he was already in Graz, at a similar higher education institution with a much longer internship, which was expecting promised transition to its former university fame. The longtime professor of physics in Graz, Gottlob Leopold Biwald (* 1731, Vienna; † 8. 9. 1805, Graz), died in the previous

year, so Neumann took over his chair and a cabinet of physics, perfectly equipped with vacuum devices. In Graz, soon again, Neumann's first-class talent for administration began to surface, and he took over the rector's stick in 1810/11.

Neumann remained in Graz less than a decade. He did not feel bad, so his younger Franconian friend Johann Joseph Precht (* 1778, Bischofsheim; † 1854, Vienna) soon became attentive to Neumann's talent for conducting higher education. During Neumann's lecturing in Ljubljana, Precht served as the local teacher in the family of Johann Taafe in the Moravian Brno, not far from Neumann's birthplace. Precht needed such a colleague! The men set up an extremely effective pair, in which Precht offered to their Viennese school high scientific and technical achievements, and his secretary Neumann took care of an exemplary managed institution and library. Their tandem a great success, as it happened a century later in Ljubljana during an exemplary collaboration between the scientist mathematicians the first rector Plemelj and the second rector of the University of Ljubljana, Rihard Zupančič. Precht and Neumann's associate, the professor of mechanical engineering at the Polytechnic, Johann Arzberger (* 1778; † 1835), provided the technologically knowledge needed in the school; first he was the director of mechanical engineering in Moravia, and then he helped Precht's introduction of gas lighting in Vienna before Edison penetrated with his vacuum electric light bulbs. Arzberger's best student and his assistant until his death was Ferdinand Jakob Redtenbacher. Among Neumann's most important colleagues at the Polytechnic in Vienna was Christian Doppler (* 1803; † 1853) between 1829 and 1835. Doppler excelled by his explanation of Doppler's effect.

Neumann lived in the center of Vienna at Ballgasse no. 987. He closely collaborated with the composer Franc Schubert (* 1797; † 1828), who vainly competed for the position of a teacher at the new musical school in Ljubljana within the framework of the Ljubljana Real school in autumn of 1816. Schubert wanted to go to Ljubljana soon after Neumann's resettlements to Vienna. Although Schubert was recommended by his and Beethoven's teacher Antonio Salieri (* 1750; † 1825), the people of Ljubljana preferred to choose a Celovec (Klagenfurt) music teacher of the Czech genus Franc Sokol (Sokoll, * 1779, Sadská; †

1822, Ljubljana). The people of Ljubljana did not see Schubert good enough as their new teacher, while their former professor Neumann wrote in the Viennese capital the songs for Schubert's music. Salieri's older brother and teacher Francesco was a Paduan pupil of violinist and mathematician Giuseppe Tartini. Unfortunately, together with the new Viennese professor Neumann, nobody could convince the people of Ljubljana for Schubert's advantage. It may also be the right case, since Ljubljana would soon become too narrow for Schubert, as it became to his friend Neumann a decade earlier.

15.10.5 Textbook about Physics

Neumann liked the book of physicist employed as a senior Bavarian financial councilor Julius Conrad Count Yelin (* 1771; † 1826) *Lehrbuch der Experimental-Naturlehre und seinem chemischen Theile, nach dem neuen System bearbeitet* (1796 Ausbach). Neumann also recommended writers of the textbooks which he preferred. Among them was the Rostock university botanist the early proponent of Lavoisier's anti-phlogiston chemistry dr. Heinrich Friedrich Link (1767 Hildesheim-1851 Berlin). Link's textbook *Grundriß der Physik für Vorlesungen* was published in Hamburg in 1798. Neumann also liked Michael Hube's (Jan Michał, 1737 Toruń (Thorn) in Northern Poland-1807 Potycz in east-central Poland) *Vollständiger und fasslicher Unterricht in der Naturlehre: in einer Reihe von Briefen*, published in several volumes in Leipzig in 1790-1791 and in 1801-182. Hube used to be Abraham Gotthelf Kästner's (1719-1800) student in Göttingen where he published his students' work *De sectionibus conicis* in Leipzig in 1755 with German translation: *Versuch einer analytischen Abhandlung von den Kegelschnitten mit einer Vorrede von A. G. Kästner* issued in Göttingen 1757. Neumann recommended the Protestant astronomer and designer of vacuum pump Johan Gottlieb Friederich Schrader's *Grundreich der Experimental-Naturlehre in Seinen Chemischen Theile* printed in Hamburg in 1804. Among Neumann's favorites was M. Hell's student the astronomer Catholic priest Longinus Anton Jungnitz's (1764 Męcince (Hermannsdorf)-1831 Wroclaw) *Grundriss der Naturlehre zum Gebrauch fuer Vorlesungen* published in Wroclaw in 1804. Neumann praised the freemasonic professor of medicine, physics and chemistry in Erlagen

Friedrich Hildebrandt's (1764 Hannover 1816 Erlangen) *Anfangsgründe der dynamischen Naturlehre* (1807, Erlangen). T. Gruber's collaborator Gren's textbook (1808, Halle) was still among Neumann's favorites together with the supporter of Rumford's theory of heat translation



Figure 15-62: Neumann's illustration of hydrostatic paradox, hydrostatic pressing of capillaries and vacuum phenomena at the end of his Latin textbook, published in Graz in 1808.

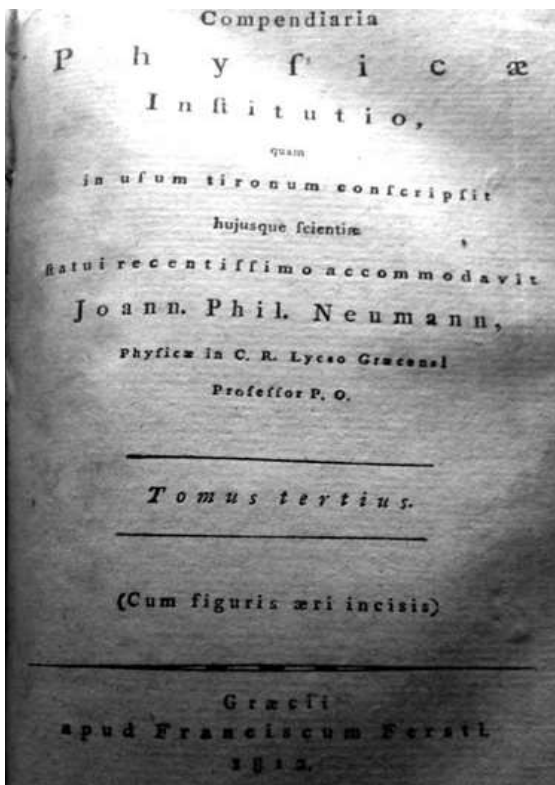

Figure 15-63: Neumann's cover page of the third part of the textbook, published in Graz in 1812, immediately after he left Ljubljana.

the first rector of Tartu university Georg Friedrich Parrot's *Grundriß der theoretischen Physic: zum Gebrauche für Vorlesungen* (1809 Riga-Leipzig). Naturally, Neumann liked the professor of chemistry who taught Justus von Liebig, the Protestant Karl Wilhelm Gottlob Kastner (1783-1857 Erlangen). Kastner published *Grundriss der Experimentalphysik* edited by Mohr and Zimmer

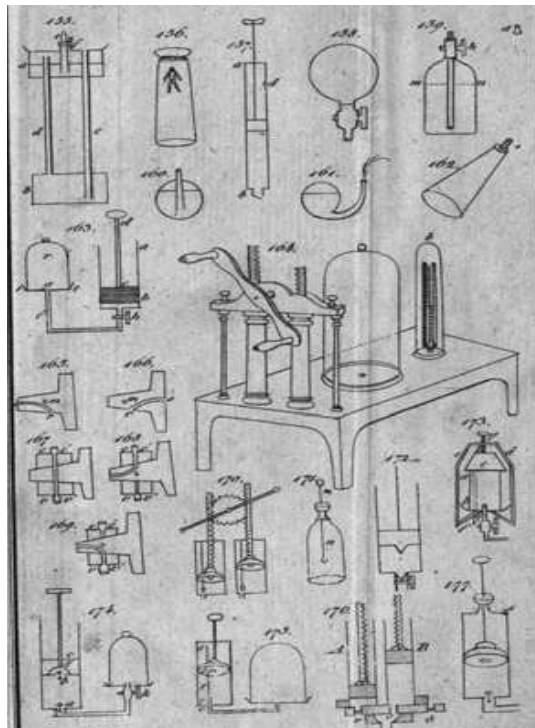

Figure 15-64: Table VIII of Figure 596 of the first part of Neumann's German textbook, which in Figures 173-177 illustrated experiments with vacuum pumps described on pages 375-378 of the first part

in Hiedelberg in 1809 and in 1810. Neumann also approved the experimental physics of Johann Tobias Mayer (1812). Neumann equally recommended the textbook of researcher of gases Kästner's student Georg Gottlieb Schmidt's (*Luftschmidt*, 1768-1837 Giessen), *Handbuch der Naturlehre* published in Giessen in 1817. Another Schmidt's textbook about the spherical trigonometry was printed in Giessen in 1817.

Neumann recommended Dutch chemistry and physics in his introduction to the textbook, including the Dutch 'sGravesande and Musschenbroek's *Institutions* (1748) and *Introductio ad philosophiam* (1762); the choice was related to Musschenbroek's valves of vacuum receivers that he used in Ljubljana. Neumann

enjoyed the French textbooks titled *Traité*, among others, like French Haüy (1806, German translation by Christian Samuel Weiss (1780 Leipzig–1856 Cheb in Bohemia) or Johann Georg

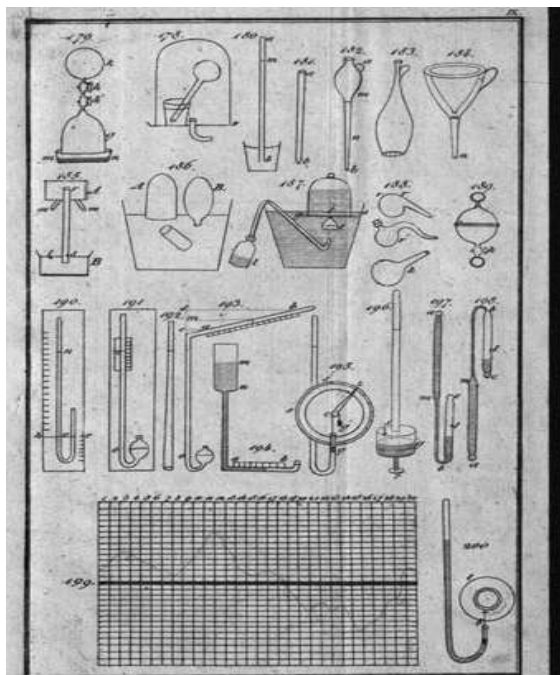

Figure 15-65: Table IX on page 598 of the first part of the Neumann German textbook from 1818, which depicts the vacuum pump described in Figure 178 of page 378 of the first part. On Figure 189 we see the Magdeburg hemispheres which Neumann introduced to his students already in Ljubljana.

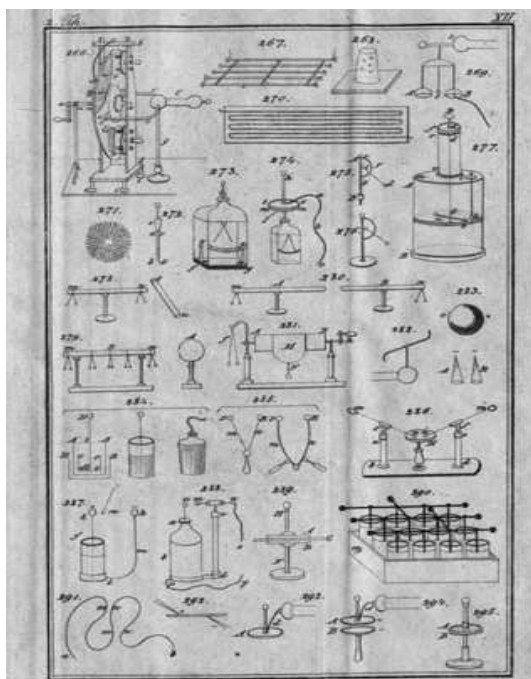

Figure 15-66: A table of images at table XII of the second part of Neumann's German language

textbook from 1820, which illustrates experiments with electricity



Figure 15-67: The front page of the magazine in which Neumann published his discussion in 1819.

Ludolph Blumhof (1774 Hannover-1825 Giessen) in 1804, A. Libes or JB Biot (1816) who also published his *Precis* in Paris in 1817. Other Neumann's favourite textbooks were published by François Sulpice Beudant (1787 Paris–1850 Paris) (*Essai*, 1815, Paris), Tiberius Cavallo (*The Elements*, 1803, London), Thomas Young (*Lectures*, 1807, London), J. Playfair (*Outlines*, 1814, Edinburgh), Ranieri Gerbi (1763-1839 Pisa) (*Elements* 1818, Pisa) and Giuseppe Saverio Poli (*Elements* 1819, Venezia). Neumann examined Cavallo and Poli's books at the library of Žiga Zois, whom Neumann visited as a professor in Ljubljana. Neumann recommended dictionaries compiled by JST Gehler (1787-1795, Leipzig), JR Meyer (1806, Arau), Hutton (1815), Brison (1781, Paris) and Alexandre Brongniart (1770 Paris–1847 Paris) in collaboration with Cuvier (1804-1805, Strasbourg). Among the histories of physics, he emphasized JC Fischer (1801-1808, Göttingen), J. Gilbert (1811, Leipzig) and the journal *Archives et découvertes et des inventions nouvelles, faites dans les science, les arts et les produits, tant en France que dans les pays étrangers* (1808, Paris: Treuttel

Würtz) with many articles of Gay-Lussac, Biot, Fourier and Oersted.¹⁹⁸⁴

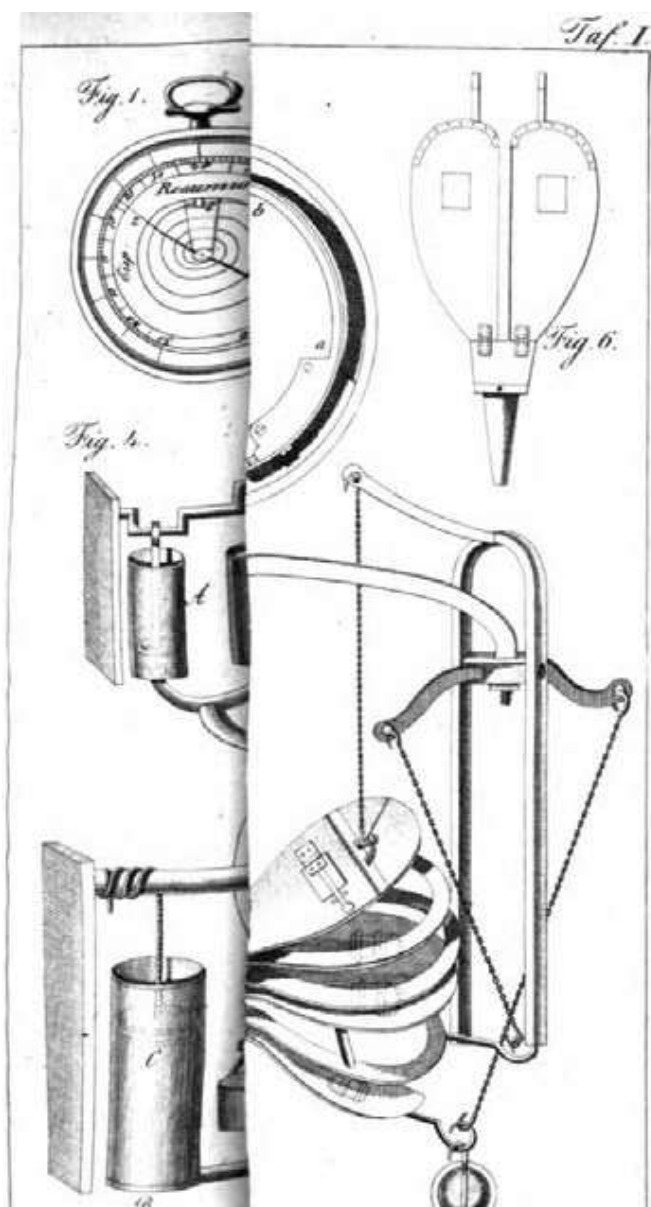

Figure 15-68: Pictures published in Neumann's discourse from 1819 on page 521 in Table I under numbers 1-36

Among Neumann's recommendations was the professor of physics, chemistry and natural sciences at Heidelberg University, Georg Adolf Suckow (* 1751; † 1813), who published *Anfangsgrunde der Physik und Chemie* (1813, Augsburg); Neumann liked the liberal Anti-Semitic Hegel's antagonist Jakob Friedrich Fries' (1773-1843 Jena) *Entwurf des Systems der theoretischen Physik* (1813, Heidelberg), Hildebrandt's and J.T. Mayer's Erlangen student Carl Wilhelm Bockmann's (1773-1821 Karlsruhe) *Leitfaden zum Gebrauch bei Vorlesungen über die*

Naturlehre (1813, Karlsruhe), Thaddäus Siber's (1774 Schrobenhausen in Bavaria-1854 Munich) *Anfangsgründe der Physik und angewandten Mathematik* (1815) and, basically, Neumann's own co-worker in Viennese Polytechnic the porcelain firm director Benjamin Scholz's (1786 Slezské Rudoltice (Rosswald) in Bohemian Silesia-1833) *Anfangsgründe der Physik als Vorbereitung zum Studium der Chemie*. After Scholz passed away, his fellow Bohemian Andreas Baumgartner took over porcelain firm directorship in 1835. The porcelain became one of the leading product of applied physicist after its secrets were revealed from the Chinese for Parisian suburb fabric of Sèvres. Neumann also recommended other technical expert writers such as the pioneering educator of pharmacists Johann Bartholomäus Trommsdorf's (1770 Erfurt-1837) *Chemisches Probierkabinet oder Nachricht von der Bereitung, den Eigenschaften und dem Gebrauche der Reagentien* (1817, Gotha), Georg Christoph Lichtenberg's (1808-1818, Vienna) editions of Lichtenberg's friend Erxleben's *Anfangsgründe der Naturlehre*, Friedrich Christian Kries' (*1768 Thorn; † 1849 Gotha) *Lehrbuch der Physik* (1816, Jena), the private tutor of brothers Humboldt Ernst Gottfried Fischer's (1754-1831) *Lehrbuch der mechanischen Naturlehre* (1819), the Heidelberg university professor of physics Georg Wilhelm Muncke's (Munck, Munke, 1772 Hilligsfeld-1847 Großkmehlen) *Anfangsgründe der Naturlehre* (1819, Heidelberg) and Wilhelm Gilbert. Among Habsburg Latin textbooks, Neumann again recommended Ambshell (1807), along with Ambshell's successor to the Viennese chair the Piarist Remigio Döttler (1812, Vienna, Trieste) and Neumann's own Graz textbook from 1808-1812.

15.10.6 Conclusion

Neumann's recommended reading were certainly in the mainstream, but he totally abandoned the Jesuitical relevant Catholic or even Habsburgian researchers. The physics in Ljubljana finally became a cosmopolite erudition where Neumann was able to recommend even the highly suspicious antiestablishment post-Kantian Jakob Friedrich Fries. Ljubljana's professors and vacuum technique researchers would find it difficult to name anyone who has so many references on the web and in the literature as exactly Neumann. Of course, the lion's share of his fame comes from cooperation with even more famous Franz Schubert, but nothing's

¹⁹⁸⁴ J. P. Neumann, *Lehrbuch* 1820, 2: XIII–XIV.

wrong with that. Glory is glorious no matter who is its godparent! Certainly, Neumann deserves a kind of memorial plate in Ljubljana or at least a street with his name, as one of the oldest members of the DVTS Alojz Paulin constantly draws attention to the fact that Slovenians are eager to call their streets in all sorts of humanists, and very reluctantly by scientists and technicians, and especially not by vacuum researchers. Neumann is an excellent opportunity to avoid this disproportionate disparity: in the same person, he combined the successful poet of Schubert's compositions and physics, skilled in experiments within a vacuum. Neumann is therefore a rare example of a famous man, in whom both humanistic and technical scholars of Slovenia can agree to praise and commemorate his glory in their capital. Near his former Viennese Polytechnic, today the University of Technology, he has his memorial record under the tower of the belfry, not far from the church, while it is by no means necessary for the people of Ljubljana to lag far behind their former Viennese capital.

16 Vacuum for Entertainments - Balloons

16.1 Vacuum Balloons

Neumann's Viennese boss Prechtl used to be one of the best theoreticians of ballooning, especially by his comments of the flight of the Carniolan Kraškovič. One of their biggest hints was the puzzle of the best balloon filaments: would it be possible to live it empty? Objects float in the liquid due to buoyancy. The biggest lift is obtained by completely emptied balloon. However, the framework of a balloon must be firm enough to withstand the external pressure and prevent implosion. Is the Vacuum Balloon Possible?

16.1.1 Exploitations in the Sixteenth Century

A quarter of century after Torricelli, Fabri described an airship in Lyon. According to Aristotle, he assumed that the air had "lightness" in contrast to the gravity of the earth or water. He wanted to get as much air as possible under high pressure in the sphere, as he anticipated that he would then be striving upward.¹⁹⁸⁵ The idea was clearly wrong also in contrast to Torricellian air pressures and even with later Lana's vacuum ballooning. Fabri's airship would certainly make a bad flight, just like Einstein's planes a quarter of millennia later, mostly because the purely theoretical considerations might be sometimes relevant for experimentation, but they are hardly ever usable for direct technological applications. In 1726, Fabri's book was acquired in the Jesuit library in Ljubljana.

Lana did not use Guericke's or Boyle's vacuum pumps, although he knew them from Schott's books. He imagined four spheres of copper sheets in which the air would be much heavier than its skeleton made of copper. When the air was exhausted from balls, they would be fastened with a belt to a wooden boat. The ship should be as light as possible so that the crew can sail like ship on the water. Each of the four spheres would be connected to a long copper tube that could be

closed by a tap: "First of all, I will assume that the air has weight like the steam. Air rises from the earth and the sea a few miles high and surrounds the Earth. The philosophers cannot deny this fact. We can prove it by pumping out air from a glass container if we cannot exhaust all the air. This reduces the weight of the container. I found the weight of the air itself at the following manner: I bought a large glass container, whose door could be closed or opened with a tap. I opened the container and warmed it up and removed the air from it. When I got most of the air out of the container, I quickly closed it so that the air would not come back. I weighed the container. Then I connected the container door to the water and opened the tap, so that the water filled most of the container. I pulled out the door from the water, drained water from the vessel, and measured the quantity and density of water. I found out that the amount of air that left the container is equal to the amount of water that filled the container. The water filled the part of the container left by the air. I again weighed the dish after I dried it well and removed the moisture. I found that the container, together with air, weighed 1 ounce¹⁹⁸⁶ more than after I washed out most of the air. The difference corresponds to the air with the volume of water that took its place. The water had a mass of 640 ounces. So, I found that the weight of air is 640 times less than the weight of the water."

He measured a 20% lower value of the ratio between the density of water and air than we acknowledge today. He used Euclid's finding of increasing the surface of a sphere with square of diameter and volume with a third exponent of diameter. He designed a hollow spheres of diameter close to 8 m with a thickness of the frame about 0.1 mm:

"In order to prepare a ball capable of lifting larger masses and transport people by air, we use 170 m² of copper¹⁹⁸⁷ weighing 140 kg...¹⁹⁸⁸ The ball will contain 326 kg¹⁹⁸⁹ of air. If the air is exhausted from the ball, three or at least two people with a

¹⁹⁸⁶ 28.35 g.

¹⁹⁸⁷ 1,232 square feet, each 372 mm long.

¹⁹⁸⁸ 308 lbs. (pound) each 453.59 g. Such amount of copper with density 8500 kg/m³ should be enough for 0.1 mm thick layer of ball with a diameter 3.68 m.

¹⁹⁸⁹ 718 lbs. 4 2/3 ounce. That mass should have a ball full of air with the diameter 3,68 m if air could be just 640 times lighter than water.

¹⁹⁸⁵ Fabri, 1669, 153.

total weight of 186 kg¹⁹⁹⁰ will be able to raise. The larger the ball, the thicker and stronger the copper plates must be. The weight of the sphere is increasing, but with the weight of the air contained, its capacity is increasing. This way bigger balls can lift heavier loads. From here we can easily see how we can build a device in the form of a ship that will float through the air."

The ship could be propelled by the rudders and sails on masts. He pointed out the operation of a later propeller and claimed that, due to air pressure, the oars or blades would cause any vessel to move. Lana did not specify the air pressure required for the propulsion but envisaged all the conditions and difficulties in making the airship: "I cannot foresee other problems that could prevent such an invention, except the largest, since God will certainly never allow the operation of a device that would cause so much disturbance in the civil and military administration." He assumed that airships could ignite boats at sea and bombard houses and fortresses. No one would be safe from surprise. The assumption of a new mode of warfare came true, although Lana did not predict any successful defense. In 1686, Lana again described his aircraft in a solid book of a large format, but without images. The book was acquired by professor of mathematics and physics B. F. Erberg for higher studies in Ljubljana several years before Vega's birth. Vega certainly liked the fictional idea when he read about it in the school library. Lana accurately described Torricelli, Boyle's and other experiments with gases and vacuum. He presented the opinions of the important Jesuits Fabri, Lana's teacher Kircher and Schott. Like other Italian Jesuits, he criticized Galileo¹⁹⁹¹ because he could not reconcile his research with Aristotle. The Jesuits of those days, like Aristotle, still claimed that the space is defined with the substance it contained, which made the absence of substance troublesome especially in the Latin descriptions. Therefore, when describing the airship, Lana avoided discussion of the vacuum, but acknowledged the existence of air pressure. The middle path was necessary, since the Jesuits, such as Lana and his friend, rector of the Roman Jesuit College D. Bartoli, had to obtain the consent to print their experimental research by the Jesuit

censors favoring Aristotle. The mathematician in Pisa, Borelli, was one of the leading researchers of possible flights. Together with Leibniz they opposed Lana's assumptions. They argued that the vacuum ball would collapse into itself, as Guericke had already witnessed in 1640 during his pumping air from wooden and bronze barrels. Despite criticism, the Jesuits continued to admire Lana's airship for a long time. That shipbuilding, of course, intended primary for navigation on the water, was one of the prestigious Jesuit technologies. The production of ships and models for them has become the most important activity of Vega's Ljubljana professor Gruber a century after Lana's book.

The Dubrovnik citizen **Brne (Bernard) Zamagna** was the pupil of his compatriot Bošković at the Jesuit College in Rome. In 1768 he studied theology there. As he used to be one of the most important Croatian Latin poets, Zamagna's rhymes stuck primarily on scientific issues.

In 1768 Zamagna published 1473 Latin hexamers in two books about Lana's ship. Other scientific questions were also involved in the poem: the fear of empty, the nature of the force of gravity, the natural science of his own censor Dubrovnik native Benedict Stay, the talk of a multitude of worlds written by the later life-long secretary of the Parisian Academy Fontenelle in 1686, Copernicus and Columbus's discoveries, magnetic declinations, difficulties in measuring the meridian, Borelli's aerodynamics, Newton's and Bošković's research of the atmosphere around the Earth and the Moon. In the year 1769, Bošković's path to California was foreseen to observe the transit of Venus across the surface of the Sun. Zamagna's song was reprinted in Graz and Vienna in 1782 and 1784 with the preface and remarks of the former Jesuit, the Hungarian Paintner, Domin's friend and classmate in Leoben in 1772. He became a priest in Sopron, and he was later promoted to the title of bishop and counselor of the Viennese court for religious questions. In his foreword Paintner summarized the entire history of the airship. In the first half of the 4th century BC the Pythagorean arithmetician Plato's model of a philosopher-king Archytas (Ἀρχύτας, 428 Tarentum (now Taranto in Southern Italy)–347 BC Tarentum) accomplished the flight of suspended

¹⁹⁹⁰ 410 lbs. 4 2/3 ounce.

¹⁹⁹¹ Domin, 1987, 175–177; Lana, 1684, 1: 3, 175, 177–178; Lana, 1686, 2: 176, 291–294; Lana, 1692, 3: 214, 215, 238, 239, 262, 297, 551.

wooden pigeons propelled by a hidden jet of compressed steam. In the 14th century, Jean Buridan's Parisian student the Augustinian bishop of Halberstadt Albert of Saxony compared the flight through the air near the fire with the buoyancy on the surface of the water with the air above it. Albert argued in his theory of impetus that the air near the fire resembles the surface of the water bordering the air. Later the Jesuit professors from Prague also discussed that interesting problem of Lana's airships.

Lana correctly calculated the buoyancy, but he did not consider the strength of the spheres. He estimated the cost of manufacturing an airship to only 100 golden coins, but due to vow of poverty, he could not even provide this relatively small sum.¹⁹⁹² Thus, he was saved from his disappointment at eventual observing the external pressure, which would surely implode his balls. Lana likewise envisioned the use of balloons to the quarter of a millennia later Potočnik Noordung's planned development of rocket and space technology.

16.1.2 *Vega and the First Balloons*

The first balloon flight was indeed a jump at the beginning of the 18th century in 1709 by Portuguese-Brazilian ex-Jesuit Gusmão in Lisbon. The Portuguese Bartholomeo de Gusmão was the first to fly. He used the device filled with a warm air and reached to the height of the roof of the royal palace. His achievements were wrapped up in the dark, as the Inquisition threw him into prison; luckily, his faithful friends helped him escape to Spain. On 17. 3. 1709 he was rewarded by the Portuguese king. Later, Gusmão failed to meet all the expectations of the authorities. For almost a century after his death, the ballooning ship was hosted by Brothers Montgolfier. They were the owners of the paper mill in Annonay, therefore they used soft and expandable frames instead of hard balls. On June 17, 1783, a balloon with diluted air passed over Paris. Among the crowd of curious people, the King Louis XVI, Benjamin Franklin and Barthélemy Faujas de Saint-Fond, naturalist at the Paris Museum, viewed the flight. Faujas immediately added the flight report to a book he published in Paris that same year. He estimated that Lana's ship would be better

opportunity compared to Montgolfier's design (Figure 16-1).¹⁹⁹³

The books related to Aerostatics went for honey. For Ljubljana's Lyceum library they acquired a dozen French, English and German works on aerostatics printed between 1783 and 1786, most of them Faujas' books. Many experts valued Montgolfier's balloon including Roy, Tillet, Brisson, Cadet, Lavoisier, Bossut, de Condorcet and Desmarest for the Parisian Academy. All of them suddenly wanted to fly through air, while the French Revolution was preparing its bloody dance on the ground.

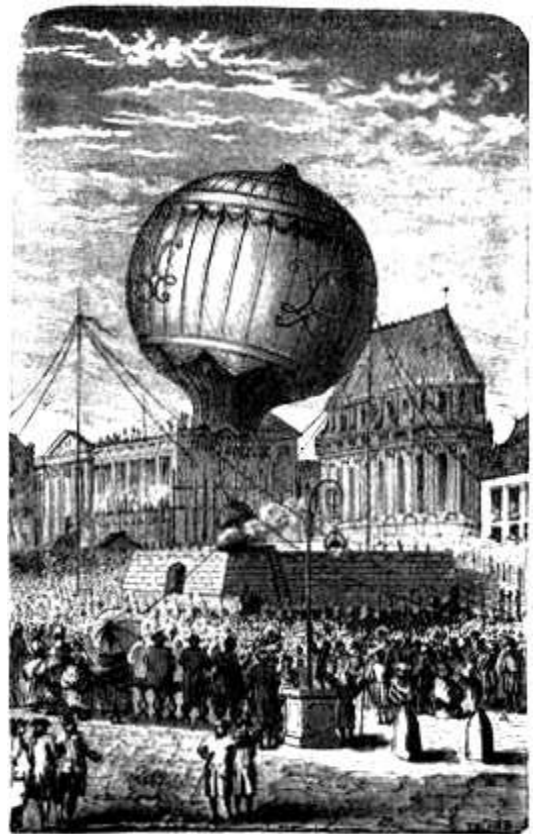

Figure 16-1: Montgolfier's Balloon above Versailles

Jurij Vega soon heard of the success of Montgolfier brothers, since the former Benedictine Franz Übelacker in translated Faujas' work after the Paris Edition within the year. Of course, the Germans were not able to confess the any French superiority, so Übelacker described four hundred years old flight surveys in Germany. On 6. 6. 1784 Vega watched the first Viennese flight of a hot-air balloon. In the same year, he was promoted to the

¹⁹⁹² Lana, 1670, paragraph VI; Domin, 1987, 177, 175.

¹⁹⁹³ Domin, 1987, 177–178; Faujas, 1784, 3 (introduction), 248–249.

lieutenant and issued another part of his mathematical lectures in Vienna. Also, the professors of physics Rozier and d'Arlandes who became Major in 1781, were also impressed with the balloons. On November 21, 1783, six minutes before the two o'clock in the afternoon, Rozier and d'Arlandes let a balloon with diluted air above La Muette in Paris. Subsequently, Rozier became the first victim of promising air traffic. During the overflow of the English Channel, his burner inflamed hydrogen in his small balloon of combined hydrogen and warmed air filaments. The Croat Ivan Baptist Horvat published the first description of a flight by aerostat balloon full of hydrogen in Buda in 1783¹⁹⁹⁴ in the later Charles's style. On the 1st of December 1783, the Sorbonne professor Jacques Alexandre César Charles and his brother Robert were flying with such a balloon for the first time on the order of the Parisian Academy. Charles chose the newly discovered hydrogen by mistake, as he thought that it was also used by Montgolfier. The decomposition of water for production of hydrogen and oxygen was discovered by Lavoisier in 1783 and published on April 1st-4th, 1783 with Meusnier and Laplace at the Parisian Academy. General Jean-Baptiste Meusnier was a correspondent member of the AR since 1776. Two days after Charles's flight, on December 3, 1783, the AR published Meusnier's hydrogen balloon flight theory. The following year, the British were impressed by the novelty.

On March 1, 1784, Franjo Josip Domin designed his hydrogen filled balloon in the courtyard of the house of Francisco Andrea de Stainer in Győr, Hungary. He has tested similar devices for seven years. On 1. 3. 1784, Domin as the first in Hungary released a balloon full of hydrogen over the courtyard of the house of Francisco Andrea de Stainer in Győr (Raab). He also assembled air pumps, fused with charcoal. Following the example of Fontana and Ingenhousz, charcoal was

¹⁹⁹⁴ Domin, 1987, *Dissertatio physica de aeris factitii genesi, natvra, et vtilitatibvs*. Tauruni: Iosephi Streibig. 1784. Reprint: *Fizikalna razprava o postanku, naravi i koristi umjetnog zraka*. Zagreb: JAZU. 165, 171–172, 175–177; Drago Grdenić, Tumačenje Dominove fizikalne razprave (in: Domin, 1987), 53–55, 82, 91, 111; Snežana Paušek - Baždar, Josip Franjo Domin, in: Domin 1987, 113–129, here p. 121; Faujas de Saint-Fond, B., *Beschreibung der Versuche mit der Luftkugel, übersetzt von Abbé Uebelacker, mit einer Abhandlung derselben, wodurch erwiesen wird, dass ein deutscher Physiker von XIV Jahrhundert der Urheber dieser Erfindung sey*, Wien 1784

used to improve the vacuum in the mercury barometer (Figure 16-2).¹⁹⁹⁵ The process was discovered in 1772 by Fontana, a professor of logic and physics in Pisa, and then in Florence, where he was also a physicist at the court of Tuscany of the Grand Duke Leopold I. Domin knew well Ingenhousz who was a doctor of the Viennese imperial family between 1768 and 1779.

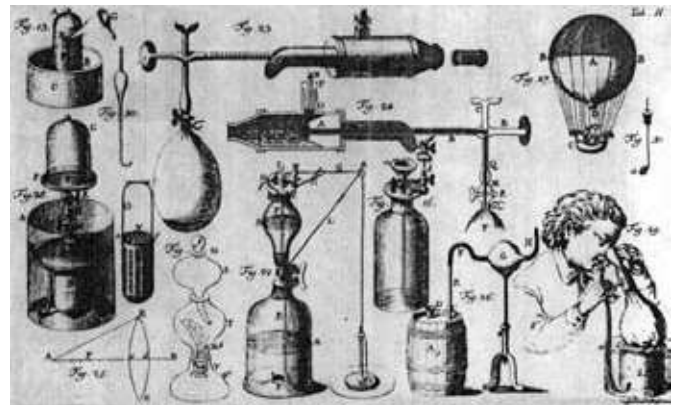

Figure 16-2: Domin's aerostat and vacuum pump (Figures 27 and 28)¹⁹⁹⁶

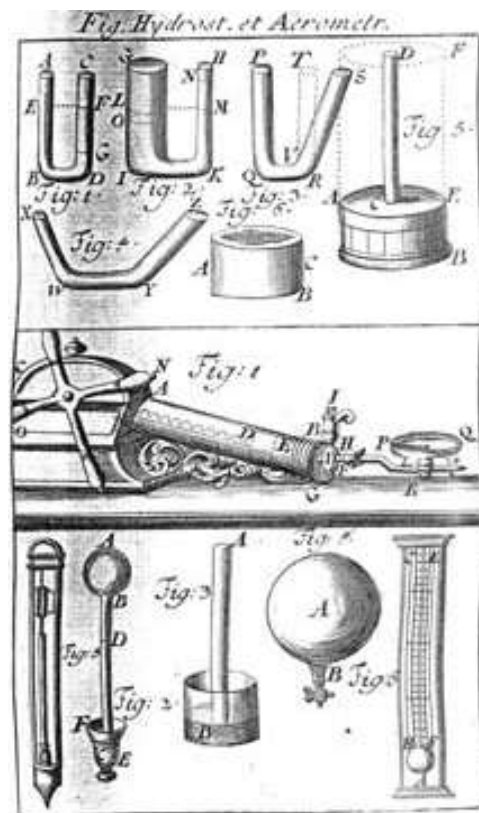

Figure 16-3: Vacuum pump (Fig. 1 in the middle) and emptied vacuum ball (Fig. 4 below) in the times of young Vega¹⁹⁹⁷

¹⁹⁹⁵ Domin, 1987, 165, 171–172, 175–177, 181–183.

¹⁹⁹⁶ Domin, 1987, at the end of a book.

Vega learned about the vacuum and balloon experiments during a study in Ljubljana and later described them in his books. In his time, the choice between a vacuum and a filled balloon was no longer questionable. As an experienced practical physicist, he rejected Lana's model, like Borelli and Leibniz before him. Vega said that "because of the pressure of the external atmosphere on the surface of hollowed empty balls, it will not be possible to thin enough the metal shells to enable resisting the weight of outside air." This caused the essence of the problem and Vega supported the charge of balloons with hydrogen¹⁹⁹⁸

16.2 A Slovenian with a Vacuum Balloon and his Last Will (on the 250th Anniversary of the Birth of the Pioneer of Slovenian Flights Gregor Kraškovič of Bloke)

16.2.1 Introduction

Neumann and his superior Prechtl closely followed the development of vacuum techniques for balloon flights, among which the flying Carniolan hero Kraškovič glittered. Upon the balloonists' tragedy on August 23, 2012 on Barje by Ljubljana, it is worth mentioning the first Slovenian balloonist Gregor Kraškovič, who published a fundamental work in the history of aviation, both in Slovenia and abroad. Kraškovič's book was printed over two centuries ago in Vienna. During his early years he performed a total of 65 flights. He tried to revitalize a century and half old idea of Lana Terzi about the flight under four vacuum balloons.

16.2.2 Training of a Future Balloonist

Gregor Kraškovič was born at Bloke in Inner Carniola. He studied the first grade of poetics in lower studies (gymnasium) in Ljubljana in 1788 with the Emperor's scholarship (Caesar) among the relatively younger schoolmates born around 1773. Kraškovič won the first prize (premier, Primae classis) immediately after two award winners Martin Rachnet from Dob and Nicolas Iggel

accompanied by Lucas Burger from Kott (Winklern) above the river Čabranka and Matheus Barthol from the parish Loški Potok (Lasserbach, Laserbach). Apart from Iggel, who afforded his studies with the help of the Umek Foundation, all three of them received the emperor's scholarship, just like Kraškovič. Burger and Barthol were even Kraškovič's relatively close neighbors. In front of Kraškovič, the first receiver of premium Sigmundus Gandin de Lilienstein (Andrej, * Hrib (Obergörschach) along the Lake Črnava in Preddvor, † 1791) was listed. He studied with the help of the Polidor de Montagnana's (Montegnana, * Italy; † 1604, Novo mesto) Foundation. The Foundation was established after the Archduke Ferdinand hinted on Montagnana on May 12, 1599, to hand over his Rogaška benefits to poor students.¹⁹⁹⁹ Their classmates were the count of Ljubljana Vincent Lichtenberg, Mathias Miller from Škofja Loka, Liburnia (Rijeka) native Franc Persich, Cerknica native Joan Petrisch, Georgius Pfeiffer from the parish of St. Martin, Ljubljana natives Michael Pinter and Andreas Potrata, Vipava native Martinus Stibiel, Škofja Loka native Antonius Uhl and Radovljica native Mathaeus Wenger. The other receivers of premium were Franc Janeshitsch of Ljubljana and Franc Okorn, along with Vipava native Johannes Slocker.



Figure 16-4: Kraškovič's scholarship during his study of rhetoric under the number 8 on October 20, 1786 (ARS, AS 14, Gubernij in Ljubljana, Registratura III, folder 46, 1801-1806, box 364)

¹⁹⁹⁷ Wolff, 1758, 1: 326/327.

¹⁹⁹⁸ Vega, 1800, 147-148, 150.

¹⁹⁹⁹ Ciperle, 2001, 120.

Kraškovič was not born at the vicinity of the Loški potok parish. Kraškovič was also not born in Vrhnika, east of Lož or Podpreska, south of the Loški brook, the areas inhabited by the Gottscheers (Kočevarji).²⁰⁰⁰ Most of his documents on his schooling in Ljubljana in the class of physicist Schaller and mathematician Anton Gruber and in Vienna with the physiologist Georg Prochaska show his native parish Bloke in Inner Carniola (Notranjska).

16.2.3 Kraškovič on the History of Aviation

In the white world, Gregor Kraškovič slightly arranged his own surname Krashoviz, perhaps for similar initiatives as his elder compatriot Jurij Vega, who still used his original surname Veba at his schools in Ljubljana. Kraškovič was also Krashoviz in Ljubljana's schools, and the unusual "k" was later added to his surname, but not in connection with the Croatian town of Kraškovíc, 100 km north of Slavonski Brod. Immediately after graduation, Kraškovič began collecting balloon data in 1789; perhaps he was helped by a youthful experience from the traditional domestic Nordic skiing in his native Bloke. In 1796, he was promoted to the rank of Doctor of Medicine at the University of Vienna;²⁰⁰¹ perhaps he helped himself with the scholarship of his distant relative, Janez Kraschkowitsch (Johann Kraschkowitsch), in the annual amount of 67 florins 6 kreuzers, which was intended for high school graduates' Viennese studies of Law and Medicine, so that the Carniolans were very interested in using it.²⁰⁰²

After the promotion, Gregor Kraškovič practiced in Vienna in 1797 as an external member of the medical faculty; he abandoned the practice the following year when the doctor of the Faculty of Medicine was also Joseph Anton Haymon, while among the philosophers were Joseph Liesganig, Anton Ambschell and Carniolan Franz Karpe.²⁰⁰³ It seems that Kraškovič left Vienna and then

served for some time in Zadar, where after his departure, on 18 August 1807, the Dalmatian guys released from the Zadar Plains a unmanned balloon in honor of Napoleon's birthday and peace treaty signed with the Russians.²⁰⁰⁴ After the death of the Varaždin county (provincial) physicist from Luxembourg, Joannis Baptist Lalangue (* 1743; † 20. 5. 1799, Varaždin), Kraškovič became his successor. In the 1800's, he was engaged in obstetrics-maternity and the education of pregnant women in Varaždin. Kraškovič was a provincial physicist in Varaždin between 1799 and 1804,²⁰⁰⁵ where he also proved himself to be the pioneer of medicine of workmen. In Varaždin, he carried a high cylinder hat in three levels or maybe a tricorne; over his white trousers he liked to wear a blue or green fringe. On February 1, 1805, as a practicing physician from Vienna and a district physicist, he reported about his 1500 vaccinations against smallpox virus in Varaždin to John Walker (* 1759; † 1830) from the London Royal Jennerian Society of Edward Jenner (* 1749; † 1823). Kraškovič vaccinated more than 110 children. Kraškovič got his Viennese vaccine from Dr. Jean De Carro (* 1770, Geneva; † 1857, Karlovy Vary (Carlsbad)); he used it as the first in the Varaždin environment. Most of the vaccinated were from poorer classes. Kraškovič also promoted vaccination in the neighboring lands in Hungary and Styria. Nearly for two years he fought in the Varaždin environment against infectious diseases of animals with such knowledge, success and happiness that the Hungarian authorities rewarded him with praise; he was also known as a botanist.²⁰⁰⁶

In the year 1808, Kraškovič and Ivan Nepomuk Menner (Maenner, Manner, Männer, * Western Austria) made the pioneering experiments with balloons. They performed their show on the possession of the emperor's royal chamberlain, the descendant of the Counts of Varaždin and the Dalmatian-Croat Slavonic ban-Sigismund Erdödy in Vepp (Vép), 8 km east of Szombathely. They used a round gas filled balloon. On its flight to the north, the balloon reached a height of 200-250 toise (fathoms) (klafter, fathom, 400-500 m). Then the balloon sailed south-east towards the then Turkish lands, as Kraškovič reported on seventy-eight pages of his historical-technical booklet on

²⁰⁰⁰ Krashoviz Greg. Carn. Lasserbach Stip. Coes 1788, Krascoviz Leonardus 1777, Krashoviz Georg. 1815 (Črnivec, 1999, 323, 442).

²⁰⁰¹ Sitar, 2010, 159.

²⁰⁰² *Amtsblatt zur Laibacher Zeitung* 19. 12. 1888, number 291.

²⁰⁰³ Hof- und Staats- Schematismus der röm. Kaiserl. Wien: Joseph Gerold, 1797, 251, 253; Wiener Universitäts schematismus für das Jahr, 1798, 72, 88, 96–97.

²⁰⁰⁴ Sitar, 2010, 159.

²⁰⁰⁵ Eleršek, 2010, 38–41; Kraškovič, Menner, 1811, 476.

²⁰⁰⁶ Eleršek, 2010, 38, 39; Kraškovič, Menner, 1811, 476.

ballooning in 1810.²⁰⁰⁷ Like Kraškovič, Menner also had a Viennese medical practice, while he worked for a general hospital for free two years long. During the war against the French, he served the army with useful hospitalizations. Together with Kraškovič, Menner was one of the first to introduce Jenner's injection of a sample taken from cow suffering from cowpox.²⁰⁰⁸ Menner served as a professor of mathematics at the Zagreb Academy between 1823 and 1841, where he was criticized as a German nationalist. In Zagreb, he printed at least ten collections of exam theses of his students in collaboration with the professor of physics, mechanic and economy Antun von Šufflay (Šufflaj, 1775 Samobor-1849) who was promoted with his Ph.D. of philosophy in Zagreb in 1803. Among their noble students was Emerik Ožegović von Barlabaševački (Emericus Osegovich, Imre, Mirko), promoted in 1828. In 1835 Menner promoted his student of mathematics of Spanish heritage Antun von Rubido de Zagorje (Antal Zuchý, * 1817 Klanjec or Madrid-1863) who married the first professional Croatian opera soprano singer the countess Sidonija Erdődy Rubido (1819 Zagreb-1888 Gornja Rijeka by Kalnik) in 1843. Antun Rubido was counsel vicegerent and a major under his general the Ban Josip Jelačić. His wife Sidonia as important member of the Illyrian movement first publicly sang the Croatian anthem in their castle in Zagorje in 1858, which was not in accordance with the supposed Menner's German nationalism.

Menner and Kraškovič learned their ballooning from other pioneers. In his balloon flights, Kraškovič proved himself as an exemplary student of the French Jean Pierre François Blanchard, who first flew over Viennese Prater on July 6, 1791. Blanchard had dreamed of flying in childhood years and the duke had already entrusted him with the construction of a water turbine near his castle at Vernon when Blanchard was a nineteen-year-old teenager. In 1777, Blanchard impressed Benjamin Franklin with his mechanical vehicle, which he

drove from Paris to Versailles in an hour and a quarter. After the invention of the balloons, Blanchard of course began to fly under them, also with the royal support. He flew over Philadelphia and, after returning to Europe, he compiled three machines; unfortunately, his air fleet was hit by a thunder which killed his only eighteen-year-old son.²⁰⁰⁹

Kraškovič curiously described Franklin's achievements;²⁰¹⁰ however, he also emphasized Fourcroy's military use of balloons for the observation and transmission of telegraphic messages between French generals Etienne (Jean-Étienne Vachier Championnet), François-Séverin Desgravières-Marceau (* 1769; † 21. 9. 1796, Altenkirchen) and Joseph Sébastien Meyer (* 1763; † 1834).²⁰¹¹ At the battlefields near Rhine, the French captain and first officer of aerostatics corps Jean-Marie-Joseph Coutelle (* 1748; † 1835) already used the ropes of the newly invented balloons of his friend Charles at the battle of Fleurs on 26 June 1794. The units of the Habsburg officer Jurij Vega attempted to prevent observational activity of the French balloons. On June 6, 1784, Jan Ingenhousz (* 1730; † 1799) released the first hot-air balloon without crew,²⁰¹² which was certainly observed by Vega, while Kraškovič was still a gymnasium student in Ljubljana. Ingenhousz was close to Kraškovič and Vega as a pioneer of the vaccination against smallpox in the Habsburg monarchy after 1768 (of course, not by Jenner's procedure), by the installation of lightning rods in cooperation with Vega's superior Freemason Major Leopold Baron Unterberger (* 1734; † 1818) and by Ingenhousz's exploration of photosynthesis and gases. Vega, on the other hand, rejected the Lana's model to be distinguished from Lana's fan Kraškovič. Like Leibniz, Vega thought that "because of the pressure of an external atmosphere on the surface of hollow emptied balls, it will not be possible for metal shells to be thinned in such a way that they would be lighter than the weight of the air that the balls contained prior to its voiding." That's why Vega preferred the hydrogen filaments in balloon.²⁰¹³ In the case of buoyancy, Vega examined the motion of Montgolfier's warmed air

²⁰⁰⁷ Kraškovič, 1810, 61.

²⁰⁰⁸ Kraškovič, Menner, 1811, 476: Positiones ex geometria quas in regia scientiarum Academia Zagradiensi die 22. Augusti 1824. publice propugnandas susceperunt ... domini Chachkovich Ladislaus, Domin Ignatius, ... [E praelectionibus Joan. Nep. Maenner, ...]; Tentamen publicum ex algebra et geometria, quod in regia scientiarum Academia Zagradiensi anno MDCCCXXXV mense Julio subivit r.d. Rubido Antonius, ... [E praelectionibus Joannis Nep. Maenner, ...].

²⁰⁰⁹ Kraškovič, 1810, 25, 36–37, 38, 43.

²⁰¹⁰ Kraškovič, 1810, 43.

²⁰¹¹ Kraškovič, 1810, 45–46.

²⁰¹² Beale, 1999, 24; Norris, 2000, 126.

²⁰¹³ Vega, 1800, 147–148, 150; Sitar, 1997, 44.

balloon,²⁰¹⁴ which was very popular for already ten years.

The French ideas were obviously very close to Kraškovič, since he began his book with a quote from Rousseau, which he had already used as an enthusiast dedicated lover of the nature; of course, he also quoted the Parisian playwright Louis-Sébastien Mercier (* 1740; † 1814).²⁰¹⁵ Among his practical examples he listed the experts such as Nicolas Louis Vauquelin (* 1763; † 1829), Klapproth, Berthelot, Fourcroy, Lavoisier, Volta, JB de Jacquin (Joseph Baron Jacquin (* 1766; † 1839)), the translator of Lavoisier's work in Berlin in 1792 chemist and pharmacist Sigismund Friedrich Hermstadt (Hermstädt, * 1760 Erfurt; † 1833 Berlin) and Gilbert.²⁰¹⁶ Gilbert was probably the famous little older Kraškovič's peer Ludwig Wilhelm Gilbert (1769-1824) who edited the main professional journal *Annalen der Physik* in Leipzig. He was probably not Wilhelm Gilbert, the legendary physician of the English queen.

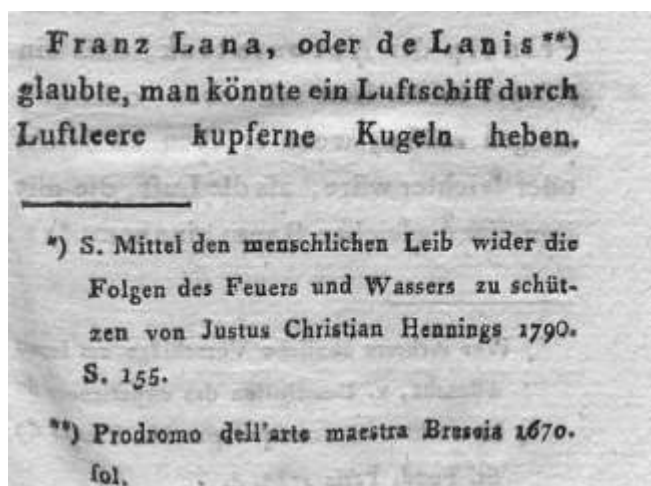

Figure 16-5: Kraškovič's notes on the hundred-forty years old ideas of the vacuum balloon of Franz de Lane Terzi from Brescia published in Lana's book *Prodromo*²⁰¹⁷

As a genuine lover of good meals of interior gourmet, Kraškovič was especially impressed by the trans-ocean voyages of importing potatoes from America, and he wanted to win the air space flights with balloons for more Transatlantic journeys.²⁰¹⁸ Of course, he started his presentation

Kraškovič's special attention was paid to **Franz de Lanis** (Jesuit Lana Terzi), who designed a vacuum balloon made of copper in 1670; his successful flight should, according to Kraškovič, be correlated with the principles of physics,²⁰¹⁹ as seen by Leibniz and the practical Otto Guericke. Francesco de Lana Tertio (Terzi) was the third child of the Brescia family; so, he signed himself as "Terzi"²⁰²⁰ In 1647 he entered the Jesuits' order. He studied under supervision of the professors Casati and Kircher at the Roman College, where he particularly observed Kircher's experiments. He studied at the Roman College in Casati's class and watched experiments at the Kircher Museum. At the Roman College, Athanasius Kircher raised many influential pupils, including Jesuit Francesco Lana Terzi of Brescia. Between 1656 and 1658, he taught philosophy in Terni north of Rome, in Rome, then in Venice. From 1675 Lana taught mathematics in Ferrara. A year before his death, he returned to the Academy Filesotici in his native Brescia. The publications of Filesotici were summed up even in the Leibniz's *Acta eruditorum*.²⁰²¹ Lana was a correspondent fellow of the Royal Society of London. According to Fabri, his religious confrere, the Jesuit Lana, published in Venice the first useful plan for a flight of vacuum balloons with human crew (Figure 16-5. Later, Johann Christoph Sturm (Sturmius, * 1635 Hilpoltstein (Mittelfranken); † 1703 Altdorf) was thinking anew about Lana's airship (Figure 16-6). The bookshop Mayr offered first part of Sturm's two-year-old book to the people of Ljubljana in 1678. Sturm's critique of Leibniz published in 1697 purchased by Erberg for the Ljubljana Jesuits in 1754 is still preserved in modern NUK.

with Dedalus and Icarus, although he may not have been aware of the later disputes between the aircraft heavier and lighter than air. Then he turned to the more modern Johann Müller Regiomontanus (* 1436; † 1476). In 1467 Regiomontanus presented the eagle made from the woods and artfully made fly made from iron which flew the perceptible distance. His first audience were the

²⁰¹⁴ Vega, *Vorlesungen* 1803, 2: 404.

²⁰¹⁵ Kraškovič, 1810, 37, 59.

²⁰¹⁶ Kraškovič, 1810, 5.

²⁰¹⁷ Kraškovič, 1810, 13–14.

²⁰¹⁸ Kraškovič, 1810, 7.

²⁰¹⁹ Kraškovič, 1810, 13–14.

²⁰²⁰ D. Grdenić, J. F. Domin, Tumačenje, In: *Fizikalna razprava o postanku, naravi i koristi umjetnog zraka* (1987), 174.

²⁰²¹ L. Thorndike, 1958, 8: 230.

local States General and the next the courtiers of the Emperor Friderik III in Nuremberg.²⁰²² In 1577, the Emperor Rudolf II ordered the dropping of a mechanical plane from the top of the Tower of Viennese St. Stephen Church.²⁰²³

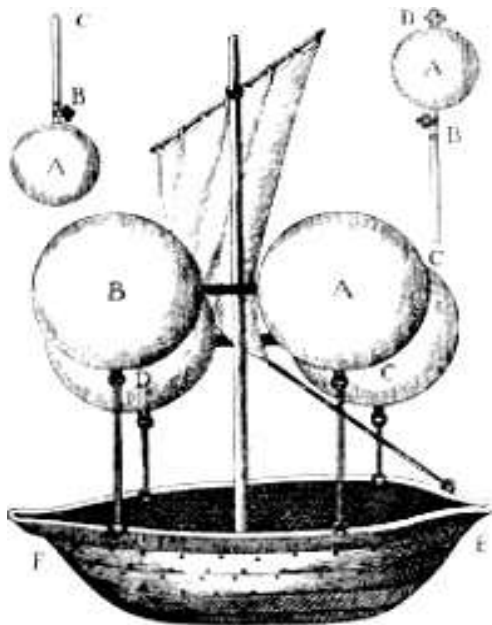

Figure 16-6: Lana's ship

In 1670, Lana became famous for production of round aircraft from copper sheets from which the air was exhausted; the idea obviously impressed the regional governor of Carniolan Volf Engelbert Auersperg at the time of his acquisition of the Lana's book. It is less likely that Volf on the roof of his Ljubljana palace tested the vacuum balloons, which still nobody designed until now. Lana's book was also read by the Ljubljana Franciscans. Leibniz has criticized Lana's idea; he thought that the vacuum ball would collapse to itself, as in his time Guericke's barrel collapsed during Guericke's similar experiments. Leibniz's concerns were reasonable, of course. Despite Leibniz's doubts, Leibniz's correspondent Philipp Lohmeier (* 1648 Magdeburg; † 1680 Lüneburg) published about the vacuum boat with balloons at the Universities of Wittenberg and Rinteln in 1676 and again after J.V. Auersperg's death in 1679.²⁰²⁴ Lohmeier began as a teacher, from 1674 to 1679 he was full professor of physics at the University of Rinteln in Lower Saxony southwest of Hannover, then professor of rhetoric at the Gymnasium Johanneum

in Lüneburg and inspector of the local Knights Academy. In 1676 in Wittenberg he published his Rinteln dissertation *De artificio navigandi per aërem* (About the art to navigate through air) which caused quite a stir, so that Wilhelm Ernst Tentzel (*1659 Greußen an der Helbe; † 1707 Dresden) discussed it in his monthly interviews (*Monatliche Unterredungen*) and thus made the event known beyond the local Faculty of Arts. Lohmeier took up the idea of the Jesuit Franciscus Lana Terzi from Brescia, who had presented the draft of an airship with building instructions in his *Prodromo* in 1670. Lana's basic idea was the plausible consideration that a body would have to rise into the air if it was lighter than the volume of air it was displacing. Lohmeier was enthusiastic about the idea of a buoyancy created by vacuum and gave lectures on the subject, as in 1674 at the University of Wittenberg. His own treatise on the possibility and technology of air navigation extended by some innovations became the subject of the examination of his pupil Franciscus David Frescheur (Prescheur, * Cassel) at the University of Rinteln in March 1676. In addition to that dissertation, Lohmeier published many pedagogical exam essays against judicial astrology (1674), starry heavens, earth, levitation, and gravity. He was praised by the leading minds of his time including his correspondence with Gottfried Wilhelm Leibniz. The subsequent also posthumous reprints and German translations of the Lohmeier's dissertation (1679, 1708 and 1784) prove the lasting interest and reputation of the deceased Lohmeier. Although the Lutheran theologian Johann Georg Walch (* 1693 Meiningen; † 1775 Jena) had plagiarized Lohmeier in 1726, Georg Christoph Lichtenberg a century after Lohmeier's publication expressed the wish that Lohmeier's dissertation should be made better known, which in 1784 led to the printing of a German translation (in Tübingen) and a bilingual, Latin-German edition of Lohmeier's book in Arolsen. At the end of the 18th century critical assessments of Lohmeier's accomplishments were made, as well as the questionable originality of some of his writings in relation to Lana and the *Collegium Experimentale Curiosum* of Sturm published in Nuremberg three years before Lohmeier's edition in 1676. In fact, Philipp Lohmeier copied verbatim his own treatise on the possibility of air navigation from the Jesuit Francesco Lana Terzi's (1631-1687) invention. Lohmeier fought for Lana's flight project. The admiration for Lana's idea even led him to lecture

²⁰²² Kraškovič, 1810, 10, 12.

²⁰²³ Kraškovič, 1810, 12.

²⁰²⁴ Thorndike, 1958, 8: 613; Tentzel, 1697, 766; Lohmeier, Rhotert, 1911, 162, 182; Walch, 1726, 1685.

about him at the University of Wittenberg in 1674 without naming Lana. He wrote a dissertation '*De artificio navigandi per aerem*', which almost literally coincides with the sixth chapter of Lana's 'Prodromo' and adds only a few broadening suggestions without notifying Lana. Lohmeier described the works of Torricelli, Boyle and Guericke who used to be a mayor in Magdeburg when Lohmeier's father was a rector of Grammar school there. Lohmeier and his student may have ignored the Jesuit Lana's priority as the Protestants who disliked their theological antagonists the Jesuits, which might be fair supposition in Terpin's time but not any more in Lohmeier and Valvasor's era several decades after the Thirty Years War ended. In any case, Lohmeier's silence about Lana forced many (Germans) in false belief that Lohmeier invented Lana's ship. In the end of his narration, Lohmeier compared aerial navigation with the inventions of sable, guns and powder.

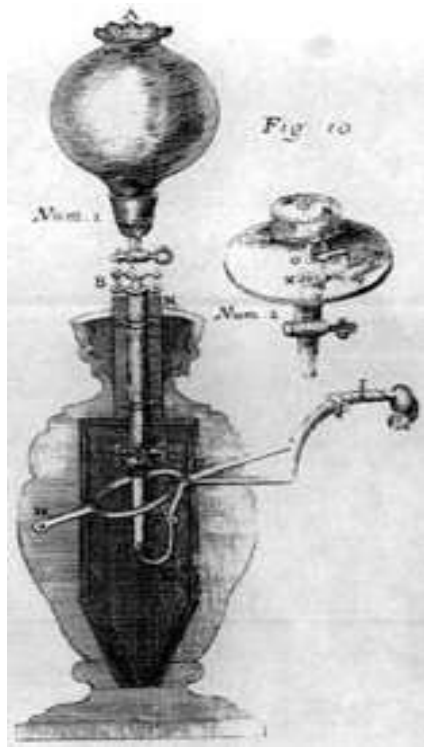

Figure 16-7: Sturm's air pump described in 1685

Lana's work was commented and pictured six years after Lana's publication by Johann Christoph Sturm (* 1635; † 1703), docent at the University of Jena, preacher and professor of mathematics in Altdorf from 1669 and later the rector; he was the father of the mathematician Leonhard Christopher Sturm.²⁰²⁵ Two years after Mayr offered Sturm's

²⁰²⁵ J. C. Sturm, *Collegium experimentale*, Norimbergae 1676, 74–99; L.Thorndike, 1958, *History of Magic*, New

book in Ljubljana, but Wolf Auersperg did not have it, even though it was bought by Auersperg's former informal student-client Valvasor.

Johann Christoph Sturm was a senior lecturer at the University of Jena, the preacher, and then professor of mathematics at the Altdorf University near Nuremberg. He was one of the most popular writers of textbooks in mathematics and physics of his time. In Ljubljana, Mayr listed four Sturm books right after Mayr's offer of Schott's works. Sturm's Physics selection was acquired by the Jesuit College in Ljubljana in 1754. He referred mainly to Fabri's vacuum issues but did not forget to describe Guericke's experiments.²⁰²⁶

Lana Terzi described four spheres of very thin copper plates: the air in them had to be much harder than a thin copper frame. The pumps would suck out the air from the spheres and Lana could fix them with the straps on a wooden aircraft shaped like a ship. The ship should be as light as possible, equipped with paddles, masts and sails. Lana's crew could supposedly navigate the air, much like water. Lana estimated that he needed 100 gold coins to make the device; but he could not provide even this relatively small sum. After the schooling in Brno, the composer Dubrovnik Jesuit Brne Zamagna wrote a poem about the lonely boat entitled the *Navia Aeria*. In 1784, he displayed his visions in Vienna.

The bettered Lana's idea was used by Brother Montgolfier a hundred years later; their balloons were rather loaded and they did not leave them completely empty. Lana was advocating solid discharged spheres, while Etienne (* 1745; † 1799) and his brother Joseph de Montgolfier (* 1740; † 1810) preferred soft and stretching balloons out of their paper mill. Their balloons were full of light steam. Out of congenital caution the Brothers Montgolfier loaded their homemade balloons with light gases and did not come completely empty. Before all their competitors, the brothers Montgolfier distinguished themselves as the owners of the paper mill in Annonay on June 5, 1783. The King Louis XVI, Benjamin Franklin and

York, 8: 223; J. G. Doppelmayr, *Historische Nachrichten*, Nürnberg 1730, 114, 129.

²⁰²⁶ Mayr, 1678, 91, 119

Barthélemy Faujas de Saint Fond attended the Montgolfier flight in Paris. Faujas added that report to his already prepared book, which was printed in Paris in 1783 and was purchased by Žiga Zois for his library in Ljubljana; the following year it was translated by the former Benedictine monk Franz Übelacker in Vienna, where Vega observed his first ascents with balloons.

The second flight under balloon filled by diluted warmed air was carried out by professor of physics Abbé Jean François Pilatre de Rozier (* 1756; † 1785) and his companion the military commander, major since 1781, François Laurent Marquis d'Arlandes (* 1742; † 1809) at La Muette at Paris on 21 November 1783 at 13:54.

To select suitable filaments of balloons, the brave aeronauts needed reliable data. The exact Felice Fontana's measurement of the density of the various gases became their fundamental guide.²⁰²⁷

Avguštin Hallerstein and his colleagues had three copies of the description of the Jesuit vacuum balloon of Lana Terzi²⁰²⁸ in their Beijing libraries, and they also read about Montgolfier's balloon. The Jesuit Hallerstein scanned even the provincial letters of the leading researcher of the vacuum Pascal,²⁰²⁹ although Pascal was a bit bitter to the Jesuits, and he sharply argued against the Jesuit Étienne Noël.²⁰³⁰

Unfortunately, Lana's ship is still waiting for a successful flight. The third part of Lana's book Natural Science Teacher was a part of the library of the Carniolan Governor general Wolf Engelbert

Auersperg, and Jesuits of Ljubljana acquired that book sixty years after the print. Lana accurately described Torricellian,²⁰³¹ Boyle's²⁰³² and other experiments with gases and vacuum. He presented the opinions of his important Jesuit co-brothers: Honorate Faber (Fabri),²⁰³³ Kircher²⁰³⁴ and Schott.²⁰³⁵ He criticized Galileo in agreement with Giovanni Francesco Vanni (1638–1709 Rome) from Lucca, the Jesuit mathematician Tommaso Ceva's Milanese brother Giovanni Ceva (1647 Milan–1734 Mantua), and other Italian Jesuits.²⁰³⁶

Both Valvasor and Volf Engelbert Auersperg purchased a Lana's work for their libraries. Six years after the edition, Lana's work was commented by Johann Christoph Sturm (* 1635; † 1703), docent at the University of Jena, preacher and professor of mathematics in Altdorf from 1669 and later rector there.²⁰³⁷ Two years after the release, Mayr offered Sturm's book in Ljubljana. Volf Auersperg did not have Sturm's work, even though Valvasor bought it. Valvasor also had Sturm's edition of Kepler's astronomy.

In Avignon, the Dominican Joseph Gallien (Gallien, 1699/1700, Saint-Paulien, France-1762/1782) thought about areas above the atmosphere, which should also be full and usable for flying; he found the principles of aerostatics based on buoyancy. Lana's ideas were handled by the Dominican meteorologist-electrician Gallien in Avignon. He published the book *L'Art de naviguer dans les airs, amusement physique et géométrique* as anonymous in 1755 and with his full name praised in 1757. In 1766, Henry Cavendish discovered extraordinary lightness of combustible air now called hydrogen after Black has already experimenting with it.²⁰³⁸ An Italian who moved to

²⁰²⁷ Priestley, 1966, 181.

²⁰²⁸ Lana's books had ex libris of French Jesuits in Beijing: "P. P. Gallor p. J. Pekin, Collegij Societatis Jesv Pekini, Veyo da Residenza de Cinanfu" (Lana Terzi, *Magisterium*; Verhaeren, 1996 *Catalogue*, p. 572–573) and with Hallerstein's bookplate "Da Vice Provinciae da China da Compania de Jesus, Collegij Societatis Jesv Pekini, Vice Provinciae Sinesis" (Francesco Lana Terzi, Prodromo, Brescia, 1670; Verhaeren, 1996 *Catalogue*, p. 971). The French Pekingese Jesuits, with their bookplate P.P. Gallor p. J. Pekin also decorated reports on vacuum research in the mercury barometer of Torricelli's heirs at the Academy of Florence, edited by count Lorenzo Magalotti (* 1637; † 1712) under the title *Saggi di naturali esperienze* (Verhaeren, 1996 *Catalogue*, p. 921 (no. 3136)). The same Bookplate had Schott's books: *Magia universalis*, *Mechanica hydraulica* and *Physica Curiosa* (Verhaeren, 1996 *Catalogue*, pp. 804–805 (nos. 2717–2719)).

²⁰²⁹ Verhaeren, 1996 *Catalogue*, p. 150.

²⁰³⁰ Saito, *O Vácuo de Pascal*, p. 51.

²⁰³¹ F. de Lana Terzi, *Magisterium Naturae et Artis*, Parma 1692, 3: 238, 262.

²⁰³² Lana, *ibidem*, 3: 239, 551.

²⁰³³ F. de Lana Terzi, *Magisterium Naturae et Artis*, Brescia 1684, 1: 3.

²⁰³⁴ F. de Lana Terzi, *Magisterium Naturae et Artis*, Brescia 1686, 2: 176; F. de Lana Terzi, *Magisterium Naturae et Artis*, Parma 1692, 3: 215; M. Torrini, *Dopo Galileo*, Firenze 1979, 143.

²⁰³⁵ F. de Lana Terzi, *Magisterium Naturae et Artis*, Parma 1692, 3: 214, 297.

²⁰³⁶ F. de Lana Terzi, *Magisterium Naturae et Artis*, Brescia 1684, 1: 175, 177–178; Torrini, *ibidem*, 96–97.

²⁰³⁷ J. C. Sturm, *Collegium experimentale*, Norimbergae 1676, 74–99; L. Thorndike, *History of Magic*, New York, 8: 223.

²⁰³⁸ Kraškovič, 1810, 15.

London, Tiberius Cavallo and Lichtenberg happily carried out similar experiments with hydrogen; Žiga Zois also kept Cavallo's book on balloons. De La Fond's experimental physics strongly influenced the Slovenian balloon travelers, but above all Carniolan erudite admired the Naples native Cavallo. In 1771 Cavallo went to England, where in 1779 he became a fellow of the Royal Society of London. He was also a member of the Royal Academy in Naples. He published a book on electricity, which went through several reprints.²⁰³⁹ In 1800, he built a refrigerator. Cavallo, like Priestley, defended the theory of phlogiston.



Figure 16-8: An arrangement of the Viennese professor of physics Anton Vanossi's (Antal Vanossy, 1683 Raab (Győr)-1757 Rome) with illustration of Lana's or Kircher's fracture of a rod magnet into halves. The Jesuit of Italian origins Vanossi also added the swimming of a fish designed for the movement of a vacuum balloon. Vanossi's book is kept at the Ljubljana Franciscans' library (Vanossi, Lana, *Placita physica de Sympathia et Antipathia deprompta ex P. Franc. de Lana S. J., Vienna: Schwendimann, 12°, 1724, pictures at the end of the book refer to pages 226 and 265*)

²⁰³⁹ Cavallo, *A complete treatise on electricity in theory and practise with original experiments*, London 1777 (2: 1782 (in Zois' Library), 4: 1795). In the Lyceum Library in Ljubljana, they also acquired another Cavallo's book: *The History and Practice of Aerostation*, London, 1785. The book was catalogued in Zois' Library (NUK-8478). It was enumerated among the books which dealt with balloon flight that were extremely popular in that time.

T. Gruber and chemistry professor at the medical faculty of the University of Halle, Gren,²⁰⁴⁰ have criticized Darwin. Darwin's ideas were accepted by the Scottman Hutton,²⁰⁴¹ whom Darwin introduced in 1774 to the Lunar Society in Birmingham. Darwin was also advocated by Cavallo,²⁰⁴² who became famous for testing paper balloons in 1782.²⁰⁴³ Cavallo was a member of the Royal Academy in Naples, and in 1803 he settled in London. Several Cavallo's works were kept in Zois's library in Ljubljana where Zois's tutor G. Gruber and his brother T. Gruber might have used them.

Of course, the ballooning experiments succeeded with Montgolfier and then with the Parisian physicist Jacques Alexandre César Charles (* 1746; † 1823) accompanied by his brother Robert. With their balloon thinly coated by linseed oil (wood finish), the brothers Charles made their taffeta balloon more flexible. They filled their balloon with hydrogen, obtained from iron or sulfuric acid. On 27 August 1783, they flew three-quarters of an hour from Paris under a 12-foot balloon, which rose within two minutes to the height of a kilometer. Of course, the then airplanes were split into two groups, in Montgolfier's filled by heated dilute air, and in Charles's filled with the flammable gas, hydrogen.²⁰⁴⁴ The head of the museum, Pilatre de Rozier, happily watched the flight of the young Montgolfier while the king himself also attended; then Pilatre de Rozier flew together with Marquis d'Arlandes.²⁰⁴⁵ They soon created a myth. A lot of brave people from lower and higher classes began to fly. The meteorological discoveries of aeronauts & under their balloons were accomplished one after another. Thus, J. Charles's Paris student, the Belgian optician Robertson (Étienne-Gaspard Robert, 1763, Liège-1837) found that the temperature of the higher air layers in the summer was not the same as in winter.²⁰⁴⁶ In 1803 he looked at the atmosphere above Hamburg at a height of 360 "toise" (klafter, fathom, about 700 m). With his traveling companion August Lhoest, they found that the impact on Bertholet's powder did not cause an explosive break at all at these temperatures of 2

²⁰⁴⁰ Friedrich Albrecht Carl Gren (* 1760; † 1798).

²⁰⁴¹ James Hutton (* 1726; † 1797).

²⁰⁴² Italian Tiberio Cavallo (* 1749; † 1809).

²⁰⁴³ Fox, 1971, 57, 59, 337; Rosenberger, 1890, 74.

²⁰⁴⁴ Kraškovič, 1810, 20.

²⁰⁴⁵ Kraškovič, 1810, 23.

²⁰⁴⁶ Kraškovič, 1810, 27–28.

degrees Celsius, high altitude, and with 26 inches of mercury barometer of diminished air pressure. The electrometer did not show any traces of electricity, since the clouds at this diluted air were extremely thin, and the solar rays did not show lively colors after their refractions through the prism.²⁰⁴⁷

In 1804, Gay-Lussac made experiments with a compass under the balloon; together with Arago, he measured changes in air pressure in a balloon above the rebelled Napoleonic Spain. At the height of 4 km, the magnetic needle did not fluctuate, and the weight of the balloon was balanced there by its lifting buoyancy; their pulse went below 30 beats per minute. The chemical analysis of the air captured at heights in a glass balloon, of course, showed that oxygen and nitrogen retained the ratio they have in the lower parts of the atmosphere.²⁰⁴⁸ Gay-Lussac's name was used for the naming of an experiment where they passed gas from a full to an empty balloon. This experiment was often expressed by R. Mayer and others in the implementation of the law of conservation of energy twenty years later. That's why we can have Gay-Lussac's experiments as the precursors of "mechanical heat theory", which was already being created by his younger compatriot Sadi Carnot (* 1796; † 1832).

Herman Boerhaave reported burning alcohol in closed containers.²⁰⁴⁹ Such an examination of physical phenomena Kraškovič described as the endless search directed against the imaginary year 2440, with which Kraškovič had already encroached on modern science fiction.²⁰⁵⁰ The flights with balloons provided for the natural science a direct testimony of the composition of the atmosphere above the clouds, the distribution of sound there, the diminutions of the gravity, the refractions of light and all about the electricity in the summits of the atmosphere.²⁰⁵¹ Kraškovič's unnamed friend, who had already merits in aviation since his youth, thought that the balloon's flight can be directed, and the pilot could even influence the winds, including storms. There was a winning prize questions that encouraged aviation inventions parallel to the research of the poles and

the interior of Africa; Paccassi also mentioned that competitive award. Kraškovič's unnamed friend was probably his frequent copilot Menner (Männer). Last but not completely least, in those times in Vienna they protected an imaginative patent with live eagles propelling a balloon, while the German inventor and musician Franz Leppich (* 1776; † 1818) in vain proposed to Napoleon his hot-air and hydrogen balloons. Hardly any more successes than those achieved by Leppich, Fjodor Vasiljevich Rastopchin (* 1763; † 1826) had in his military tasks in Moscow.

Kraškovič correctly realized that the knowledge of high atmospheric variable winds would enable us to anticipate the storms that threaten the ships at sea.²⁰⁵² Already d'Alembert studied the influence of the Moon and the Sun on the tides of the atmosphere as the cause of the winds, and accurate calculus were added by Edmund Halley.²⁰⁵³

16.2.4 *Kraškovič's Balloons and Parachutes (Paragliders)*

On March 4, 1810, Kraškovič and Menner launched their balloon made of a taffeta with a diameter of sixteen feet at the grandeur entrance of the Napoleonic minister of war Louis-Alexandre Berthier later marshal 1st Prince of Wagram Sovereign Prince of Neuchâtel (Neuschatel, 1753-1815). Their provisional "airport" was envisioned at the University of Vienna under the auspices of the court astronomer, the former Jesuit Franz von Paul Triesnecker (Drissenecker, * 1745; † 1817), the successor to Maximilian Hell. They reached a height of 150 klafter (fathoms), that is, close to 300 m, and then they landed a plane with a fixed parachute in Viennese Leopoldstadt without any damage.²⁰⁵⁴ The Count Francesco Zambecari (* 1752, Bologna; † 1812, Bologna) impressed Kraškovič with his balloon flight in a company with Pasquale Andreoli (* 1777; † 1837) over Bologna in 1783 and then above Vienna; while flying in ice-cold frost, Zambecari had his two fingers frozen.

The speed of the wind was measured with the praised D. Burton's anemometric device, compiled after experiments of Robert Hooke and William

²⁰⁴⁷ Kraškovič, 1810, 48.

²⁰⁴⁸ Kraškovič, 1810, 49.

²⁰⁴⁹ Kraškovič, 1810, 52.

²⁰⁵⁰ Kraškovič, 1810, 55.

²⁰⁵¹ Kraškovič, 1810, 58.

²⁰⁵² Kraškovič, 1810, 64.

²⁰⁵³ Kraškovič, 1810, 59.

²⁰⁵⁴ Kraškovič, 1810, 62.

Derham (* 1657; † 1735) with windmills probably by the preacher Boerhaave's biographer William Burton M. D. at Windsor in 1730s and 1740s.²⁰⁵⁵

While the Spanish ships sailed from Mexico to Spain for thirty days, the balloon flight could last only thirteen days, and from England to Philadelphia it was supposed to arrive under the balloon even within seven days. At the same time, Kaps from Gdansk (Danzig) found a way to keep the combustible air, that is, the hydrogen, in the balloons long as during three months without losses,²⁰⁵⁶ at least insofar as losses were then accurately measured. Kraškovič finished his history of aviation, undoubtedly the first such work under the pen of the Slovenian writer, with his surprisingly extensive reading list in German, French, English, Italian and Spanish languages;²⁰⁵⁷ Kraškovič was a straight polyglot, and he began to collect material for the book about aeronautics already during his studies in Ljubljana.

Despite his book and flights in Vienna, the successful doctor of cutaneous and venereal diseases Kraškovič was not completely satisfied. He wanted to go home, which, if he moved to the then new Illyrian province, was at the same time a departure to the French Empire. The chief police commissioner of the Illyrian Provinces, the former officer serving in English army in America the freemason Louis-Toussaint de la Moussaye (* 1778, Rennes; † 1854, Paris) recommended Kraškovič to Raphael Zelli. The former intendant of Upper Austria Louis-Toussaint de la Moussaye agitated for Kraškovič's return to the Illyrian province's chair of professor in Ljubljana on December 26, 1810: "Mr. Kraskovich, a doctor of medicine, born in Illyria, glorified for his literary works, aerostat, chemistry, is famous in Vienna for the treatment of venereal diseases. For the past five years he performed a physics service in one of today's Illyrian states and now for already fourteen years he is living in Vienna. He also graduated at the University of Vienna. He would like to return to his homeland if he could hope to get there a job and a title that would at least partly compensate for his losses after leaving Vienna. Since I had the opportunity to meet him in Vienna and he turned to me for submitting a request to the Marshal (Auguste de Marmont), I would like to do this because Mr. Kraškovich boasted as an extremely

talented doctor and I think it would be worth a lot if you acquire him."²⁰⁵⁸

Unfortunately, Kraškovič, to whom his Viennese sweetheart has just born a son, did not make the transition to the University of Ljubljana. So, the Carniolans missed the chance to enjoy Kraškovič's flights. Kraškovič was not only a great aeronaut but was also interested in the safety of pilots equipped with parachutes. Therefore, he described in detail the leap from a 145-foot-high building in Brittany in north-western France of a convicted prisoner of St. Louis (Port Louis) citadel Dominicus Dufort on September 29, 1777. Dominicus Dufort (* 1753) was sentenced for life which made him brave. He jumped under Fontagne's parachute from a height of 145 feet in Brittany.²⁰⁵⁹ His tool was probably different from later Pierre-Joseph Fontaine's (1810-1877) parachute designed in 1845. The relative of cardinal Richelieu ex-governor Emmanuel-Armand de Vignerot du Plessis-Richelieu, duc d'Aiguillon (1720-1788), the professor Rennes of local academy and ten thousand others observed the heroic leap. Of course, Dufort (Du Fort) earned his freedom and some censorship, and the next French Emperor Napoleon III was subsequently imprisoned in the neighboring cell later.

Kraškovič's enthusiasm about aeronautics soon excited the other Carniolans. On March 28, 1798, Vodnik reported about Jurij Veba (Vega), who is "born Carniolan, as far as I know." Vodnik set Vega as the example. In his own terms, Vodnik's conditional sentence is very surprising, since Vodnik should have a better knowledge of his four years elder Ljubljana schoolmate Vega.²⁰⁶⁰ Like Vega in Vienna or Vodnik in his Lublana Novice (Ljubljana News), even the nearly paralyzed Žiga Zois liked Montgolfier's ballooning. Therefore, Zois loved to read Cavallo's books, as Cavallo was one of the most popular Zois scientific sources. Zois also liked to watch Montgolfier's report. Upon the first contacts of the Slovenes with the French Revolutionary armies, Vodnik, otherwise not yet a convinced Napoleon's supporter, was also the spokesperson for French novelties of those days. He began to get news from Paris. On November 22, 1797, Vodnik reported on the Parisian "ride in the air" (October 22, 1797) of Charles's student

²⁰⁵⁵ Kraškovič, 1810, 66-67.

²⁰⁵⁶ Kraškovič, 1810, 69, 71.

²⁰⁵⁷ Kraškovič, 1810, 72-78.

²⁰⁵⁸ Tavzes, 1929, 44.

²⁰⁵⁹ Kraškovič, 1810, 13.

²⁰⁶⁰ Vodnik, *ibidem*, 75.

André-Jacques Garnerin (1769-1823) when he flew under the balloon, "after heating the air to float like spruce wood on the water." In that case, above then Parisian suburb at the height 700 m, he used the first modern parachute shaped like umbrella with a diameter of 10 m tied with sixteen ropes. That parachute was not open throughout beginning of a jump. Vodnik reported to the residents of Ljubljana only one month after the event! Fourteen years earlier, the brother Montgolfier flew, and similar experiments were soon made by the people of Vienna. Vodnik certainly saw Zois's copy of the German translation of a book about Montgolfier (1783), which was subsequently evaluated to 6 kr after Zois' death. In his translation on pages 9-36, the priest Uebelacker described the history of ballooning with the achievements of Lana Terzi, Leibniz, the Dominican Joseph Galien (Gallien) in 1755 at the high school in Avignon, and Cavallo. Saint-Fond devoted his book to the French Field Marshal, and on the ninth plate he painted Lana's boat. On the remaining nine copper plates, he immortalized many details of Montgolfier's experiment, including the shape of the devices and the filling of the balloon.

In 1811, Menner and Kraškovič's dropped a hen, cat and other pets from their flying balloon during their first manned flight. They flew 70 km long, under the warmed air balloon by the Hungarian sky between Budapest and Gyöngyös: the cat survived the test and cheered the crowd or vice versa, which the Hungarians recently immortalized in their commemorative postage stamp in 1983.

Kraškovič completed a total of 65 flights. Above Pest he flew together with his colleague, doctor Menner, on June 3, 1811 and on 20 February 1812. They started their performances in Bratislava on 6 August 1811. On 15 September 1811, after a take-off at half-past six, they flew over 3 km to the Hungarian village Rajka (Ragendorf) across the Danube on the other side of Slovakian-Hungarian border near the modern triple border between Slovakia, Hungary and Austria. During their flight, both doctors onboard examined signs of altitude sickness due to diluted air.

The crowds and the archdukes with their wives applauded Kraškovič and his copilot at their launch; the latter gave a great gift to the brave aeronauts. Obviously, Kraškovič was the head of a courageous couple, since the Viennese report

wrote about his flight, and Menner was only noted within the text. A hundred years later, Novi Sad newspapers quoted on the alleged Kraškovič's Baranja or Slavonian origin.²⁰⁶¹



Figure 16-9: Menner's (and Kraškovič's) flight from 1811 and their brave cat on the Hungarian stamp of 1983. Later destiny of that heroic cat is still under investigations

16.2.5 Prechtl on Kraškovič

Few weeks after Napoleonic victorious battle of Marengo, early in June 1810, Kraškovič, together with Menner (Männer), exhibited their balloon in the Viennese Spanish Riding School (Spanische Hofreitschule) inside Hofburg. Its diameter was 22 feet balloon and circumference 72 feet of deer skin. Behind the balloon was a safety parachute, as described by Valentin Vodnik in 1797, immediately after its first use of Paris. Upon the arrival of the prince of Neuschatel (Neuchâtel), a small balloon was launched to check the winds in higher altitudes of the atmosphere. People watched the device and could not wait for flight; on August

²⁰⁶¹ Kiss, 2011, 1053-1054; Kraškovič, Menner, 1811, 475; the journal *Zastava* (Novi Sad) 2. 11. 1911; Eleršek, 2010, 38.

13, 1810, Kraškovič and Menner flew for the first time from Prater in front of the courtiers and numerous audiences; Kraškovič was researching hydrogen and warmed air balloons, and he equipped one with a parachute. According to Lana Terzi's plan, he used four hollow spheres that lifted their aircraft by buoyancy. A rather unfortunate balloon performance was described professionally two weeks later and supported with advice in the leading Viennese weekly. The writer signed himself as "Pr." He was certainly Neumann's later superior Johann Joseph Ritter von Prechtl. On the mathematical basis, Prechtl studied the flight of birds resembling a possible human Icarus's event in support of Jakob Degen (* 1760, Switzerland; † 1848, Vienna), who had flown with a hydrogen balloon in 1808. In November of the same year in Prater Degen performed the first controlled flight, and finally he excelled airplanes heavier than air. From 1809 to 1810 Prechtl lectured at the Trieste Real and Navigation School as the heir of the Jesuit Franjo Orlando. At the time of Kraškovič's flight, Prechtl returned to Vienna. During the next five years, he founded the Viennese Polytechnic Institute, today's Viennese Technical University. He also worked on gas lighting and vacuum techniques at the dawn of the invention of the cathode-ray tube.

Prechtl explicitly described how Kraškovič first sent to the atmosphere a smaller balloon that soon disappeared behind the horizon to warm up the spectators and check the wind in upper layers of the atmosphere. They lifted their second smaller balloon along with a tiny parachute; at a small height, a parachute separated from the balloon and brought an undamaged egg in the basket to the ground. Three other small balloons connected with threads turned with the wind towards the north; the middle one of them was filled with a gaseous hydrogen mixture with air and the other two were filled with hydrogen.²⁰⁶² At a considerable height, the middle balloon entered the stage, burst open and exploded. Hardly the spectators recovered from the rebuke when the larger balloon was followed by a small parachute, which the wind also drove up north to the edge of the horizon behind the trees by the banks of Danube river; only there a parachute was by itself separated from the balloon, without any spectators being able to see most of the events. Then the machine was raised in the form of a small boat made of taffeta, coated by

linseed oil (wood finish), under four significantly big balloons, with which Kraškovič was supposed to realize the idea of Lana Terzi and save Lana's flight problem. On this occasion, their too easily announced alleged airship was left to fate, as it soon lost its balance and was routinely steeped downwards. The roof with a mast made according to the Lana's depiction turned to the ground, worn by the uneven winding of balloons, like its predecessors among the balloons. The main fault of Kraškovič's design of Lana's ideas was the uneven shipping of four balloons which were supposed to stay in the same horizontal plane. Because of winds they did not, which ruined the balance of the craft. Prechtl did not specifically report on the fillings of those balloons which could have been vacuumized as Lana suggested in the first place. In the end, the main balloon with a capacity of 4,200 cubic feet (150 m³) was launched; it split many carefully designed balloons, which dropped individually from the height to let their animals downwards. One of these balloons, unfortunately, had a hole on the upper side, through which it lost a quarter of its hydrogen filament. In the absence of a new filler for the replacement of lost gas, this flaky balloon floated like a loose sail. It had a high flight, while its lifting force (buoyancy) balanced the weight of its own load.

Upon the description of these Kraškovič's experiments, the observer Prechtl afforded some benevolent advices. He stressed the lack of tension in the balloon, which is related to external weather conditions; the increased concern is necessary for large aerospace projects, because in this new field of Kraškovič's research with balloons, the advanced learned data quickly change the previous physical knowledges and beliefs. Kraškovič and Menner performed their preliminary experiments with the parachute in absolute windless tranquility; they hoped for the case of windless cloudlessness at the high altitude from which the parachute could descend after separation from the balloon. In such windless quietness, the experiment would undoubtedly be perfectly displayed to the viewers. Due to stronger winds on higher elevations, the balloon package above Prater quickly deviated from the visible field of the spectators towards the north. In that case Kraškovič should have shortened the parachute by at least a half, so that the balloon could reach the desired height, before the parachute would separate from the balloon by

²⁰⁶² Kraškovič, Menner, 1810, 287; Eleršek, 2010, 39.

itself, tear off, and drop. However, if the upper winds did not drive the parachute balloons so urgently, those experiments would lose the glamor for spectators. Also, a balloon filled with Oxyhydrogen (Knallgas) had to fall due to the wind. An experiment to make Lana's ideas possible could be happily carried out as soon as Kraškovič took to his heart that the center of gravity of the entire plane should be distributed to the extremity of the ship's shaft. To ensure the success of the experiment even more, he should use the slightly larger four lifting balloons. The shaft of the ship must be longer and coated with hardwood so that it can be lifted by the buoyant (pulling) balloon force without any damage. The outer mast must be lightweight, made only from scratched paper. By any other construction, the ship would be rocking and rolling for so long until the center of gravity of the entire airship dropped down to the ground and the excess weight of the mast roof. In addition, it can be very difficult, if not impossible, to make and fill all four balloons so equally to have the same buoyancy; even with the same equally strong evaporation or leakage of gas stored in balloons, the buoyancy of individual balloons is increasingly unevenly lost in the air, so that the ship is pulled from the desired horizontal position.²⁰⁶³

In contrast to the filled balloons, Lana's four copper vacuum balloons that Lana himself proposed to lift the airship would have always exactly same buoyancy force if they could only be made. Even nowadays, two centuries later, the unresolved problem remains the pumping out towards the total vacuum inside the balloon framework, which would withstand a huge external pressure.

Finally, Prechtl thoughtfully contemplated his opinion about the failed experiment with a large balloon: when any unpredictable case causes an accident, its relaxation is not only in our power. Such coincidences can be prevented from large aerospace shows with the utmost care and caution. Inserting a filler into a balloon is very important for the operation of a composite light aircraft, but it is subject to damage. It is understandable that it does not seem fine to damage the needs and expectations of the gathered viewers. Furthermore, it is not possible to publicly raise a large balloon without a recalculated charge of an excess material with a stock in the extent of at least half of the total

filler; so, we need to double the filler with the filling device.

Prechtl advised the excessive filling as a protection from losses due to leakage of the balloon but he did not specifically consider reductions of pressure in higher atmospheric layers.



Figure 16-10: Austrian stamp showing the flight of Johann Georg Stuver (Stubenrauch, * 1732 Oberliezheim in Swabia; † 1804 Vienna) over the Viennese Prater on July 6, 1784, before Kraškovič came to study in the imperial city. Of course, the flight was viewed by Jurij Vega, who was confirmed at the second regiment of the imperial artillery on 17 April 1780.

In addition to the fatal shreds of the balloon, there is another coincidence that can only interfere with the corresponding charge and can also occur in the case of a large surplus of the filling substances. During charging with sulfuric acid acquired by pouring the water on glowing iron parts for production of hydrogen, problems with zinc ointment placed in the back of the filling can occur. With all caution, the researcher will be uncomfortable with this experiment, so that his balloon could be affected; boarding would likely become uneasy. If everything is good at the scene,

²⁰⁶³ Kraškovič, Menner, 1810, 288; Eleršek, 2010, 39.

then the costs will not easily exceed the remaining stocks of the filling substance or the potential drop in the purchased supplies. When we consider everything, we see that the course of this experiment, with the care of his majesty of the emperor, by which Kraškovič became accessible to the prescribed certificates, fully justified Kraškovič's personal flight in a manned balloon. Moreover, on this occasion, it is not possible to deny that the spectators of the Viennese audience are honorable and exemplary during such failures. While in other major cities the folks usually follow similar misfortunes with stormy scenes, the Viennese people seem barely dissatisfied not to see what they were promised for their money. They take it diligently, they move away from the scene peacefully, but when they get a high voice, it is an expression of sympathy with the entrepreneur,²⁰⁶⁴ Kraškovič.

For the end, Prechtl politely greeted the people of Vienna. At the same time, he prophetically advised and announced the flights of Kraškovič and Menner in a manned balloon, which followed a few months later. Of course, the aeronauts were no longer such special useful feature a quarter of a century after Montgolfier, but only a few of them were born in the Habsburg monarchy like Kraškovič. Certainly, a great money and prestige was involved in then aeronautics, therefore Prechtl demanded his own shares.

Kraškovič carried his sixth flight over the Danube in a balloon on 20 November 1814, according to Laibacher Wochenblatt report published on 14. 12. 1814;²⁰⁶⁵ the report noted Kraškovič's testimony of a scene from his youth on the Adriatic Sea, perhaps during his service in Zadar. In a special note, Kraškovič was emphasized as a born Carniolan; he flew 10 km north-west at a height of 1 km. He did not dare to get higher because of the cautionary example of James Ballerum James Sadler (* 1753; † 1828) whose valve got frozen during his flight. Later, in the beginning of October 1815, Kraškovič flew to delight the Peace Congress in Vienna.²⁰⁶⁶

Kraškovič soon got excited imitators among Slovenes. Among the most expensive physical

devices at the gymnasium in Koper, a rubber balloon was purchased with a tap of brass, which was probably intended for exploring gases. It was bought for 58 florins or 4.5 DM in 1867. In 1904/05, Maks Samec the Younger (* June 27, 1881; † June 1, 1964) began to fly with balloons for research purposes as well. On 24th of May 1908, at 11:55, he rose under the double-manned balloon, which was administered by Ludwig's son dr. Arthur Boltzmann (* 1881; † 1952). The copilot Samec checked how the luminosity is increasing with height.²⁰⁶⁷ During the exploration of balloon flights, the Ljubljana baron Codelli identified the advantages of their size, and in 1910 on five typed pages he designed a huge steel balloon nicknamed Dreadnought following the idea of Ober-lieutenant Wallach. The imposing balloon was 1 km long with a diameter of 100 m designed for the transport of 20 000 passengers at the velocity of 160 km/h. Sorry to say, no passenger ever embarked. Those designs resembling the unfortunate Titanic were appealing similarly as their modern copies of spacecrafts of Jeff Bezos or Elon Musk.

16.2.6 Inner Carniolan Kraškovič in Dubrovnik

In the late 1817, Kraškovič published a translation of Benjamin Waterhouse's (* 1754; † 1846) pamphlet against smoking and drinking spirits, where he signed as M. Kraskowitz.²⁰⁶⁸ Of course, Kraškovič hated the smoking because it could become fatal during his flights under balloons filled with hydrogen. Like Kraškovič, the American professor Waterhouse of Harvard published a paper about the vaccination in 1800. Kraškovič's colleague in Dubrovnik Dr. Luca Stulli (* 1772; † 1828) used to be the Bolognese student in the classes of Luigi Galvani, the anatomist Carlo Mondini (* 1729, Bologna; † 1803) and Gaetano Gaspar Uttini (1741-1817) as the initiator of the vaccination in Bologna in 1806. Dr. Luca Stulli was the first to carry out Jenner's vaccination in Dubrovnik with the vaccine of Luigi Aloys Caren (* 1766, Pavia; † 1810, Vienna) in 1800. In April 1799 with the confirmation next year Stulli was employed as one five physicists responsible for the city hospital. After his

²⁰⁶⁴ Kraškovič, Menner, 1810, 289; Eleršek, 2010, 39.

²⁰⁶⁵ *Der Sammler ein Unterhaltungsblatt (Wien: Anton Doll)*, 2/69: 286 (9. 6. 1810), 2/98: 402 (16. 8. 1810); Sitar, 2010, 161; Žmavc, 2010, 60.

²⁰⁶⁶ Freksa, 1919.

²⁰⁶⁷ Sitar, 1985, 49–50.

²⁰⁶⁸ Waterhouse, Kraškovič, 1817; *Medicinische Schriftsteller-Lexicon* (ed. Adolph Carl Peter Callisen). Copenhagen: Königl. Taubstummen-Institute, 1834, 20: 421.

Bolognese promotion in 1796, Stulli visited Felice Fontana in Florence. Stulli showed to the initiator of neurology Domenico Cotugno (* 1734, Ruvo di Puglia; † 1822, Naples) in Naples the first Galvanic experiment outside the narrow circle of Galvani's own experiments with galvanic electricity.²⁰⁶⁹ In 1772, Felice Fontana as a physicist at the court of future Emperor the Toscana Archduke Leopold II in Florence, discovered the adsorption of gases on hot wood charcoal, which we nowadays know as getters. He was the priest and brother of the mathematician of the Piarist order. He worked as a professor of logic and physics in Pisa and then in Florence. Fontana's gettinger was assembled by extinguishing the burner without contact with the outside air. With this, the adsorption of charcoal has been saved for the air in the recipient. Laibacher Wochenblatt reported on the importance of accurate measurements of the density of various gases acquired by the experiments of the priest Fontana from Tuscany after the report on the dissertation of Mustel from Rouen on the circulation of liquids in plants (Krauten).²⁰⁷⁰ François Georges Mustel (1719 Rouen-1803 Rouen) was a promotor of cultivated potatoes in Normandy and the member of Rouen royal agricultural society from 1771 as well as the member of RS of London. His *Traité théorique et pratique de la végétation, contenant plusieurs expériences nouvelles et démonstratives sur l'économie végétale et sur la culture des arbres, par M. Mustel* was translated in Italian and English language in Phil. Trans. in 1773/74. He must not be confused with the younger Nicolas-Alexandre Mustel (1724/36-1804/06).

In 1808, Stulli became a vaccination supervisor in Dubrovnik. On 23 July 1822, the Dubrovnik district physicist (kreisarzt, kreisphysicus, protomedicus) Kraskovich reported to the Dubrovnik District Office and to the governor of the allegedly chemical volcanic causes of detonation phenomena resembling the earthquake on the island of Mljet (Meleda). In the coming months, the problems of Mljet has interested the proponent of electrical theories Dalmatian proto-medic in Zadar dr. Guglielmo Menis (Vilim, William, Willelmo, * 1790 Artegna north of Udine, † 1850 Trieste) in his letter sent to the Dubrovnik doctor Stulli, published at the end of 1823. The event in Mljet was also discussed by the

Dalmatian marine engineer temporary district engineer for public construction, water and roads in Dubrovnik Antonio Luigi de Romanò (Romano) in his report for the provisional director of the factory in Dubrovnik and in his discussions of opinions of Kraškovič, Stulli, Galvani's nephew Giuseppe Aldini and others in his Venetian book in 1828. The astronomer Johann von Littrow tried to offer his solutions and the young later leading Viennese physicist Andreas Baumgartner (* 1793; † 1865) promoted his own ideas.



Figure 16-11: Kraškovič and Menner in balloons at Prater in honor of the Viennese Peace Congress in 1815 on the drawing of those times

Arago became interested in that strange drumming under the island of Mljet after he received Stulli's letter and the attached book. The Viennese authorities invited into the research the geologist Scipio Breislak, an inspector for potassium nitrate and gunpowder in Milan, and the investigator of electromagnetism the Barnabite priest Pietro Configliachi (* 1777, Milano; † 1844, Cernobbio). Configliachi was the pupil and successor of A. Volta in Pavia as well as researcher of the human fish Proteus. According to the book of Paul Partsh (* 1791; † 1856) from the Viennese Mineralogical Cabinet issued in 1826, Kraskovich have died in the meantime;²⁰⁷¹ he was replaced by Joseph Derchich (Derčić) as a Dubrovnik district physicist. Due to the increased drumming, all islanders from Mljet escaped to the Dalmatian coast in August and September 1823, and the professor at the Viennese Polytechnic Institute Franz Riepl and Partsch came to investigate in Mljet for the entire month of 1824. The strange noises started on March 22, 1822 and in March

²⁰⁶⁹ Bazala, 1978, 269.

²⁰⁷⁰ *Laibacher Wochenblatt*, 1776, 2/15: 231–234.

²⁰⁷¹ Partsch, 1826, 101, 108, 118.

1824. They lasted until 3 September 1825 with a shorter repetition of 18 February 1826.²⁰⁷²

There is nothing fairer than the old lady death. The close encounter with her revealed the background of the many travels of the first Slovenian aviator. He presented his life story outside of his flying glory and his vacuum techniques developed for filling his hydrogen balloons.

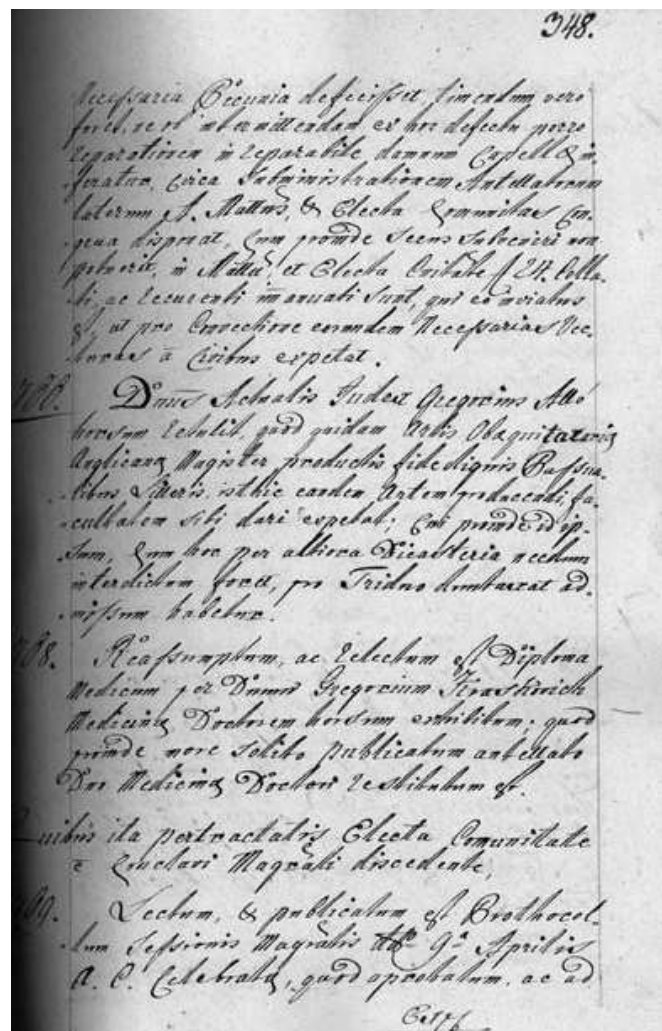

Figure 16-12: A honorary diploma of Gregor Kraškovič in Varaždin was presented in 1799 (HR-DAVŽ-2, 1799, p. 348, No. 768)

The first Slovene balloonist Gregor Kraškovič (* 3. 3. 1767, Studenec of Bloke in today's Župan (Mayor's) house, † 1823, Pale by Dubrovnik) was a younger contemporary of the second famous Slovenian physician, Balthasar Hacquet (* 1739/1745; † 1815, Vienna). Hacquet came to Idrija a couple of months before Kraškovič peeped into the world. Hacquet left Ljubljana just before

²⁰⁷² Cournot, 1827, 247–249.

Kraškovič started the last year of his lower studies there. Thus, both scholars met each other only in Vienna in the last five years of Hacquet's life; they did not live very far from each other at all, and Hacquet was able to see the well-visited Kraškovič's flights with his balloons during his stay in Vienna, which Kraškovič filled with the latest novelties of then vacuum technique by the exclamations of admiring viewers.

16.2.7 Testament

On 2. 1. 1823 a priest walked to Pile beside the city walls of the then Dubrovnik. He brought together prominent Catholic and Orthodox traders from the neighborhood to witness an oral transmission to the last wish of a gravely sick powerless Dubrovnik district doctor and researcher of vacuum balloon filling techniques, Gregor Kraškovič. The good-natured guests were astonished by the performance of a teenager Gregor Hanner (* 20 August 1807, Vienna). The kid was the high schoolboy at local gymnasium, who quite surprised the guests after his godfather Kraškovič declared him as his natural son and the only heir.

Although Kraškovič's fellow medical practitioners were not at his bedside, Dubrovnik's ancient dwellings ranged from stories from the newly discovered details of the life of a Slovenian doctor, world-renowned innovator of modern vacuum techniques for balloon filling and barometric measurements of heights. He had no help available in this world and soon he closed his eyes forever at Pile in four in the morning on 5 January 1823.

Kraškovič, as a careful father, matriculated his son to the Piarists' Dubrovnik lower studies, while at the same time he invited the kid to spend his time in pharmacy examining his surgical and vacuum techniques in the belief that the boy will later study those sciences in Vienna. The plan, after all, was somewhat confused later, because instead of surgery in Vienna, Hanner preferred to study philosophy and theology. Kraškovič worked closely with the teachers of his son in those times. He also enclosed a letter dated 15 June 1822, signed on 17 June 1822 to his letter mailed from the island of Lastovo; it was a one-sided letter from Mljet addressed to the Dubrovnik Archbishopric, accompanied by reports from a local preacher and bishop from the secondary

school in Dubrovnik. The great attention was drawn to the report of Mr. Kraškovič's physics report on detonations in Mljet²⁰⁷³ related to underground vacuum and electricity. On 16 July 1822, the rector and the prefect of the Piarist school in Dubrovnik, a linguist and archaeologist Francesco Maria Appendini (1768 Poirino near Torino–1837 Zadar) from Dubrovnik reported to the Dubrovnik Governorate. He wrote a bilateral one-page letter about the detonations on the island of Mljet, which began on June 24, 1822. They had already ceased; on the first page he mentioned the influence of the island caves. Francesco Maria Appendini was a student of Dubrovnik native Marko Faustin Galjuf. In 1803 Francesco Maria Appendini published his *"Notizie Istorico-Critiche Sulla Antichità, Storia, e Letteratura de' Ragusei"* in two volumes. Together with his brother the professor of mathematics Piarist Urbano Appendini (1777 Poirino-1834 Zadar), he organized the teacher's preparatory school in Zadar. Francesco Maria Appendini's letter about Mljet was registered on 19. 7. 1822 and on 2. 8. 1822 with the signature of Giovanni Tromba, the commissioner of the Dubrovnik Archdiocese. After his studies of mathematics in Rome and astronomy in Firenze, Urbano Appendini taught mathematics in Dubrovnik in 1795-1824, until he became the head of Zadar Lyceum and soon the head of all gymnasiums in Dalmatia. His successor in Dubrovnik at that time was the secular pastor Giovanni Battista Campsi (Ivan) who became the professor of mathematics, natural sciences and physics in Dubrovnik.²⁰⁷⁴ Campsi was probably a native from today's Shkodra in Albania, but obviously he did not promote enough Hanner's interest in vacuum techniques.

All his times of studies of gymnasiums and during his studies in Vienna Hanner used primarily his father's legacy; Kraškovič knew too well how well it suits to the growing pupil, since he himself was compelled to grumble many doors of the wealthy to get through his studies, and financing of his balloon gaskets and valves. In this regard, Kraškovič also had an extremely happy hand in choosing a caretaker for his son's legacy. His friend Franc Ludvik Regner knight Bleyleben (Franz Ludwig Regnier Ritter von Bleyleben,

Vjenceslav Nepomuk, * 1795 Chotimir in Brno city-district; † 23. 12. 1854 Nin by Zadar) achieved even the payment of 600 florins as Kraškovič's last annual salary for Hanner, although Kraškovič died immediately in the beginning of 1823. At the same time, Regner provided a regular supply of money for the maintenance of Kraškovič's son. In 1843-1844, Franz Ludwig Regner Ritter von Bleyleben was a district commissary of Zadar.²⁰⁷⁵ The family Regner Bleyleben achieved the noble rank under the emperor Rudolf II and settled in Moravia.

16.2.8 Books on Vacuum Techniques

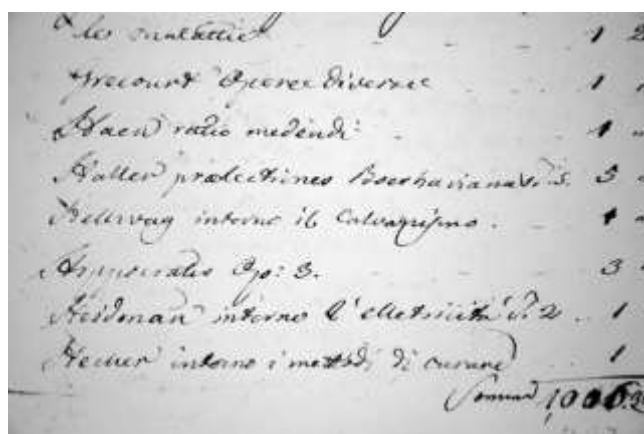

Figure 16-13: Heidmann and Hellwag's manual for the study of electrical and vacuum phenomena, listed in Kraškovič's legacy on the second and fourth place, counting from the bottom. Above them are the books of the Boerhaave's pupils (HR DADU 156, Sez. E, Fasc. VI, No. 45).

In Kraškovič's legacy, a collection of mainly professional books for medicine and vacuum techniques was selected. They were recorded in his settlement of Pile; the members of the official commission catalogued Kraškovič's gold after less than a week, and they catalogued his books and other belongings one month after Kraškovič's death on February 5, 1823. The legacy included unusually many goldsmiths' products, table and portable watches, telescope and medical devices, designed and based on modern achievements in vacuum techniques; there were also many expected personal things.

²⁰⁷³ HR DADU 81, 1822, Tern. VII, noted on no. 4070/374 and no. 345.

²⁰⁷⁴ HR DADU 81, 1822, Tern. VII, no. 297; *Almanacco*, 1819, 122.

²⁰⁷⁵ *Gazzetta (ufficiale) di Zara*, 6. 2. 1835, p. 42; Wagner, Kudler, Dolinar (Dolliner), 1839, 495; *Kayserslicher Und Königlicher Wie auch Ertzhertzoglicher Dann Dero Haupt- und Residentz-Stadt Wien Staats- und Standes-Calender, Auf das Gnaden-reiche Jahr ... Mit einem Schematismo gezieret. Cum privilegio Caesareo speciali*. Johann Baptist Schönwetter, 1843: 391, 1844: 396.

Some items from the legacy were controversial, since Kraškovič was not the owner of his Dubrovnik flat and some vacuum and other accessories were available to him because of his profession; authorities were trying to get them back when they installed a new physician as Kraškovič's replacement. Regner as a manager showed a tremendous degree of commitment to acquire as much as possible for the son of his late friend Kraškovič.

For his scientific career, of course, the most interesting were Kraškovič's books focused on gases, vacuum and electricity. Among dozens of medical and other aids, basically, the manuals on which Kraškovič relied as a vacuum researcher and a chemist are of interest here. On the eighth page, the commission began a list of his books under the subtitle *Libri, Carte Geografiche e Globi Terrestri*. There were eight maps, according to the note, they were written in Kraškovič's language.²⁰⁷⁶ Of course, it is difficult to imagine something Slovenian in those times before the map of Peter Kozler, which came out only a quarter of a century later. Kraškovič's domestic language was therefore probably used as a designation for German language. The commission followed their notes with two small globes of the Earth, each rated for one forint. Only then did the townspeople commission begin their listing of books in alphabetical order, since the first in the row was the work of Venetian Prospero Alpini (* 1553; † 1617) with his two books, among which the second was his famous *Medicina Egiptiorum Libri 4*. After Arnoldi's English grammar, there was Avicenna's Arabic Medicine which followed principles and canons in two copies that show Kraškovič's extraordinary classical education. Avicenna, in contrast to Aristotle, proved the possibility of motions in a vacuum.

Kraškovič has purchased numerous works on venereal and female diseases, including Johann Friedrich Fritze's and Giambattista Monteggia's²⁰⁷⁷ books; of course, Kraškovič did not miss the book of vaccinating of his Swiss friend Jean De Carro,²⁰⁷⁸ who moved to the Imperial city in 1795 and sent the vaccine from

Vienna to Varaždin for Kraškovič.²⁰⁷⁹ Kraškovič bought the books of Boerhaave's pupils: the *Ratio medendi in nosocomio practico Vindobonensi* of Anton de Haen (* 1704; † 1776) estimated at 1 forints, Albrecht Haller's *Praelectiones Boerhavinus* and van Swieten's comments on Boerhaave. Herman Boerhaave together with Musschenbroek's family developed vacuum pumps in Leyden, and in 1712 he started using a vacuum pump in his chemical laboratory.

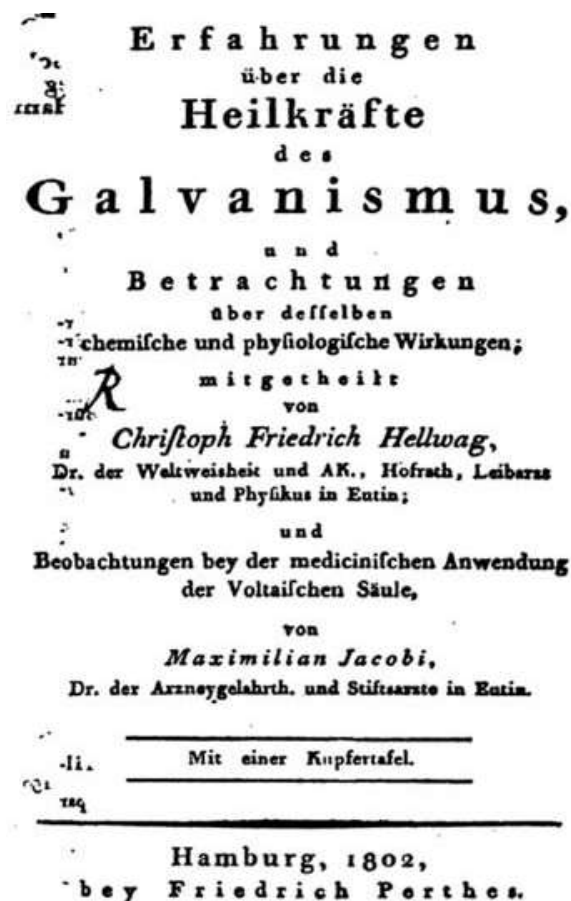

Figure 16-14: The cover page of Hellweg and Jacobi's *Treatment on Electricity Treatment* issued in 1802 and used by Kraškovič.

Kraškovič read the great famous work of Christoph Friedrich Hellweg (* 1754; † 1835) about the pioneering healings with electricity. Hellweg received his doctorate in Tübingen.²⁰⁸⁰ He became the pioneer of Jenner's vaccination in the south of Schleswig-Holstein,²⁰⁸¹ much like Kraškovič in Varaždin. Hellweg was interested in Newton's theory of colors.²⁰⁸² He believed that we did not

²⁰⁷⁶ *Mappe numero ottanta otto a Lui lingue*, valued at 7 florins 20 kreuzers (HR DADU, Sez. E, Fasc. VI, no. 45).

²⁰⁷⁷ Monteggia. 1792/1806. *Compendio sulle malattie veneree*, Pavia, Venezia, Milano.

²⁰⁷⁸ Kraškovič, 1805, 479.

²⁰⁷⁹ Carro, *Intorno la vaccinazione*, valued at 20 kr (Carro, Portenschlag, 1802).

²⁰⁸⁰ Hellweg, 1781.

²⁰⁸¹ Pfaff, Hellweg, 1800.

²⁰⁸² Hellweg, 1835.

have to do with seven simple colors, but with only four simple colors or rays of different refractions. In doing so, he refused certain ideas of the Jesuits A. Kircher, Newton, Goethe's Jesuit predecessor Louis Bertrand Castel (* 1688; † 1757), and Leonhard Euler. He corresponded with Goethe and Kant, and he published a botanical study of a geranium plant in 1776. Kraškovič bought Hellwag's 136 pages long book with a sketch about the pioneering medical treatments with electricity. In 1802 Hellwag's writing was supplemented by the son of the philosopher Friedrich Heinrich Jacobi, Maximilian Jacobi (* 1775; † 1858); in those days, Maximilian Jacobi, along with Hellwag was a doctor in the city of Eutin in Ostholstein; as Goethe's correspondent and initiator of the psychological studies of delusions. Hellwag and Jakobi described their experience in connecting patients to Volta's batteries and introduced developed vacuum techniques.²⁰⁸³ In those times still poorly tested treatment with the help of Volta's batteries certainly did not always bring just the innocent pain to the obedient patients.

*P. T. Herr Schmidt, k. k. Rath, Stabsfeld-
arzte, und Prof. an der k. k.
Josephinischen Akademie.*

— — — *Schütz (Georg) Lieutenant bey
der k. k. Artillerie.*

— — — *Terrix (v.) Obristlieutenant.*

— — — *Thürkhaim (Ludw. Freyhr. v.)*

— — — *Tomasoni (v.) Ritter.*

— — — *Vega (v.) Major bey der k. k.
Artillerie.*

— — — *Wrbna (Graf Rudolph v.)*

— — — *Zauner (Peter).*

Für das Kabinet im k. k. Gashaufe.

Sechs Ungenannte in Prag.

Ein Ungenannter in Schemnitz.

Acht Ungenannte in Wien.

Figure 16-15: Jurij Vega as an early purchaser of Heidmann's book, noted in the 9th line of the second part of Heidmann's Manual on Electricity and Vacuum Technology of the Year 1799. Kraškovič as well as Vega used that book.

²⁰⁸³ Hellwag, Jacobi, 1802.

In 1818, Hellwag wrote about Euclid's eleventh principle, which is nowadays rather quoted as the fifth postulate. In the following decades, debates on the fifth postulate opened the door to modern non-Euclidean geometry. In 1824, Hellwag published work on the movements in a living and inanimate world.²⁰⁸⁴

Kraškovič certainly also read classical Hippocratic books in three volumes, estimated at 3 forints. Most of all, Kraškovič liked the textbook of his co-worker, the Viennese physician Johann Florian Anton Heidmann written against Volta in support of Galvani's theory of electricity.²⁰⁸⁵ Heidmann dedicated the book to a long-time professor of mathematics and a Jesuit writer of the history of the Ljubljana College in the period from 1772 to 1778, Joseph Jakob Liberatus Maffei von Glattfort (* August 15, 1742, Gorizia, † 1807, Vienna). Maffei was assistant to Gabriel Gruber and benefactor of Jurij Vega. The

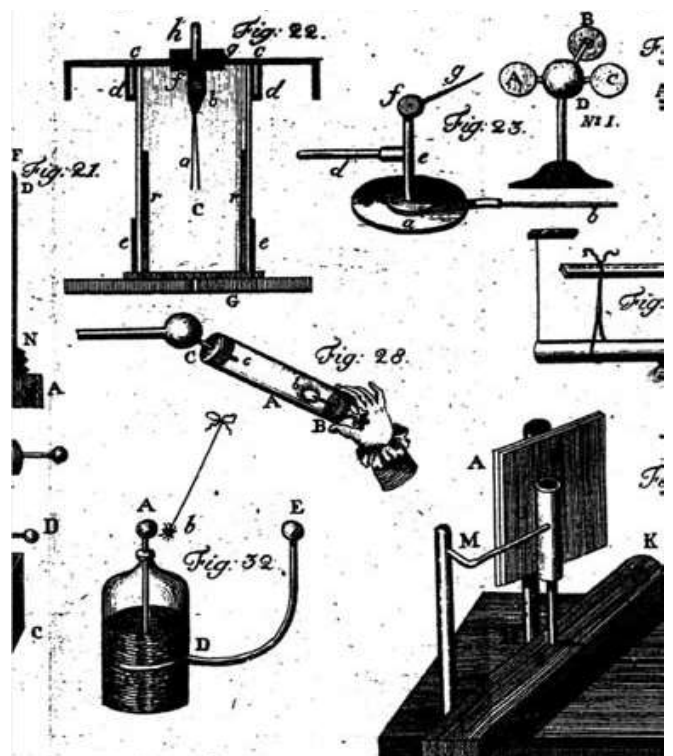

Figure 16-16: The third panel of images with the predecessors of the cathode-ray tubes on figure 28 from the first part of Heidmann's manual on electricity published in 1799, which was used by Kraškovič.

²⁰⁸⁴ Christoph Friedrich Hellwag, *Physik des unbelebten und des belebten entwickelt unter Forschung nach der Ursache der fortgesetzten Bewegung*. Hamburg, 1824.

²⁰⁸⁵ Heidmann, 1807, 97–104.

freemason Maffei was very popular among his students, and Vega also devoted to Maffei his second edition of the logarithmic-trigonometric manual in 1800. Maffei used to be a tutor of mechanics and physics, and then even the secretary of the later Field Marshal of Prince Maria Colloredo-Walsey; just before the publication of Heidmann's work, he became a pontiff in Old Boleslav, northeast of Prague in the crownlands of the Bohemian kingdom. the freemason Maffei was really very popular among his students and Kraškovič might have met him.

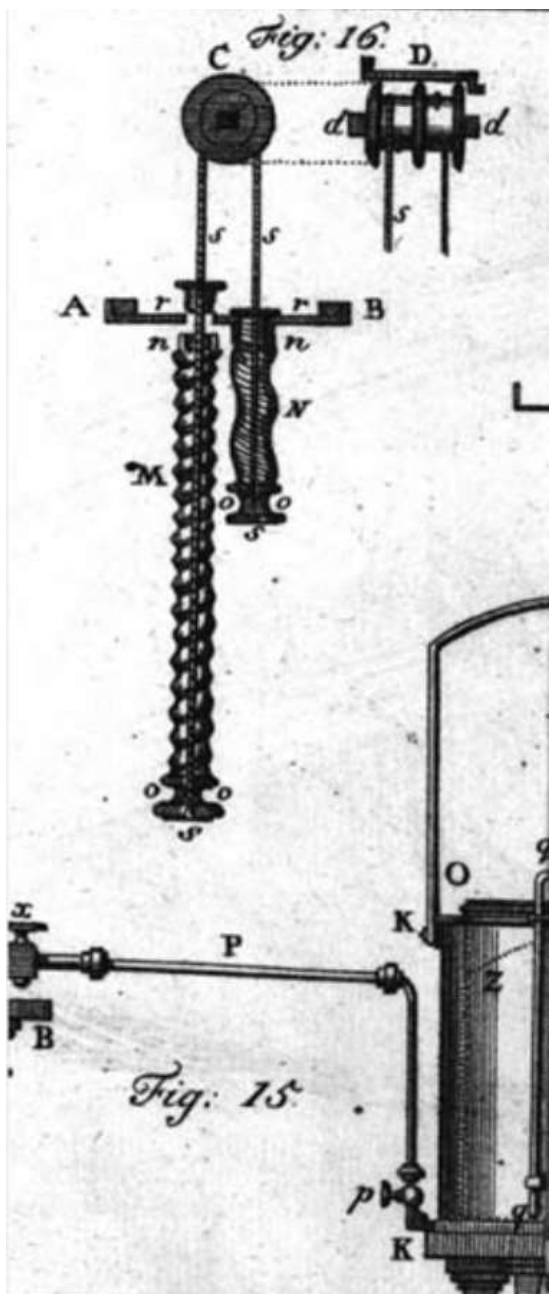

Figure 16-17: The fifth, last plate of images from the first part of Heidmann's manual about electricity and vacuum technology issued in 1799, which was used by Kraškovič.

Heidmann was promoted at the Viennese Medical School in 1797, just after Kraškovič. In 1804, as a member of the Viennese Medical School, Heidmann lodged at Weyburggasse number 964²⁰⁸⁶ in the very center of the city east of Graben, not far from the then-Kraškovič's office in the district of Wieden. In 1804, after Volta's inventions of batteries, Heidmann published a study of the use of electroplating electricity to check the whereabouts of apparently dead people. From a modern point of view, he worked on quite cruel experiments with strong electrical currents applied to animals,²⁰⁸⁷ but the views of those days were different. He devoted his book to his and Kraškovič's teacher Georg Prochaska. In 1837, Heidmann was among the first members of the Viennese Medical Society and served as its first secretary.

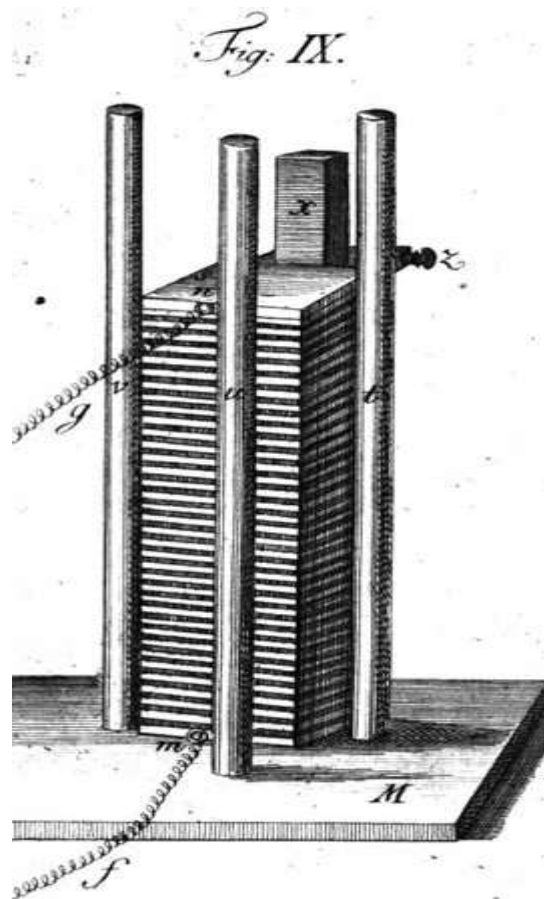

Figure 16-18: Figure IX with a battery from Heidmann's Handbook of Electricity and Vacuum Technology of 1804

²⁰⁸⁶ Noted as Anton Haidman (Phillebois, 1798, 60; *Hof- und Staats- Schematismus der röm. Kaiserl. auch kaiserl.-königl. und erzherzoglichen Haupt- und Residenz-Stadt Wien*. Wien: Joseph Gerold, 1804, 305).

²⁰⁸⁷ Heidmann, 1804.

Heidmann assumed that the operation of electricity in a vacuum induces most of the chemical phenomena;²⁰⁸⁸ the assumption was further exacerbated by subsequent researchers, so that we blame local surface disorder of outwards neutral electric charges for many biological effects nowadays.²⁰⁸⁹

Heidmann quoted the inventor of the vacuum pump Otto Guericke²⁰⁹⁰ as well as the first serious historian of vacuum devices and electrical engineering, Joseph Priestley. Heidmann was particularly interested in Voltaic inventions, as was Beccaria, Euler's Berliner student Johan Carl Wilcke's (* 1732 Wismar; † 1796 Stockholm) electrophorus of 1762 and Wilcke's eight years older Russian-German mentor-colleague Franc Aepinus. They all explored Volta's electrophorus. Heidmann knew about the publications of former Ljubljana physicist and rector Ambshell about electricity in glass. Heidmann saw the electrophorus in Simon Eberle's (* 1756; † 24 December 1827, Vienna) physics and natural science cabinet established in 1795. Shortly thereafter, in 1801, the poor priest Eberle was quickly retired for the sake of his excessive spending of money, certainly committed by the purchases of expensive electrophorus and vacuum pumps.

Of course, Eberle was among the pre-subscribers of the second part of Heidmann's book on March 25, 1799, along with the artillery major Jurij Vega.²⁰⁹¹ Heidmann was particularly interested in the theory of electrophorus of Jan Ingenhousz (* 1730; † 1799).²⁰⁹² Together with other papers of those years, it was based on the early achievements of the Hallerstein's Pekingese Jesuits. Heidmann summaries of the experiments of Jacques Alexandre Cesar Charles and others with the oxidation of metals by electric sparks in a vacuum and inflammable air (hydrogen)²⁰⁹³ were of great interest to Kraškovič when he was looking for suitable charges for his hydrogen balloons. Heidmann obtained very pure hydrogen for his electrodynamic experiments in the same way as Kraškovič for his balloons, that is, by oxidation of

iron or zinc with sulfuric acid, which he still named as vitriolic acid according to old habit of medieval times. He evacuated the receiver to achieve the lower pressure of 1/168 bar, which was then an enviable grade of vacuum. The iron sulphides like pyrite also attracted a magnet in an empty space, as was proved by the French mineralogist Jean-Claude Delamétherie (Métherie, * 1734; † 1817) beyond the then-war-colored Iron Curtain in Paris. In vacuum experiments, Heidmann set up one inch long golden conductor under a 42 cm cubic inch (0.7 liter) bell and let the current of the heavily charged battery through it to cause the oxidation of the surface of the conductor.

In the second experiment, the recipient disk and part of the cable were wrapped with white paper, so that both papers became scarlet after the flow of electricity. Only a part of the wrapping paper was covered with a thin layer of gold, while a part of the conductor was covered with the lime.²⁰⁹⁴ The lime coverage of metal leaflets in the hydrogen atmosphere was as good as in the oxygen atmosphere during Heidmann's repetitions of the experiments of Kraškovič's Parisian model Charles.²⁰⁹⁵

Kraškovič bought the Art of Medicine of Johannes Hirn. Kraškovič also acquired the indispensable Chemistry²⁰⁹⁶ and Pharmacy, compiled by father and son Jacquin. Joseph Franz Baron Jacquin (* 1766; † 1839) and his father Nikolaus Joseph Baron Jacquin (* 1727; † 1817) were, of course, the nephew and brother of Ingenhousz's wife. In 1797 Joseph Franz Jacquin inherited the botanical department after the dead of his father Nikolaus Joseph Baron Jacquin (1727-1817) passed away. He introduced Lavoisier's Chemistry to the Viennese University.

Kraškovič did not miss even two copies of the book on the obstetrics of his Luxembourg predecessor in the position of district physician Joannis Baptiste Lalangue, which was considered

²⁰⁸⁸ Heidmann, 1799, 1: III (book valued on 1 fl).

²⁰⁸⁹ Naji, Sarabadani, Dean, Podgornik, 2012, 24.

²⁰⁹⁰ Qiericke (Heidmann, 1799, 12–13).

²⁰⁹¹ Heidmann, 1799, 2: II, IV.

²⁰⁹² Heidmann, 1799, 1: 305.

²⁰⁹³ Heidmann, 1799, 2: 245–246.

²⁰⁹⁴ Heidmann, 1799, 2: 247.

²⁰⁹⁵ Heidmann, 1799, 2: 255.

²⁰⁹⁶ Kraškovič used the *Lehrbuch der allgemeinen und medicinische Chymie* of the younger Jacquin printed in 1810, or perhaps somewhat older *Anfangsgründe der medicinisch-practischen Chymie: zum Gebrauche seiner Vorlesungen* of his father.

as the first Croatian written professional medicine.²⁰⁹⁷

The famous Avicenna and both Jacquins were not the only important writers of several different books in Kraškovič's collection. Kraškovič also acquired several works of the professor of pathology in Vilnius Joseph Franko (1771-1842) and the father of modern pathology Giambattista Morgagni (1682-1771). Kraškovič read Giambattista Morgagni's letter on anatomy.

Kraškovič examined the works on fevers and practical experiences of the first director of the Viennese General Hospital, Joseph Baron Quarin (1733-1814) who served as the physician of Maria Theresia after van Swieten and Ingenhousz. Kraškovič cultivated his love for experiments by reading some older work of Antony Vallisneri (1661-1730), a student of Marcello Malpighi. Kraškovič was also interested in the healing effect of mineral waters, so he read about them in the works of the freemasonic father of the German seaside resorted medical baths Samuel Gottlieb Vogel (1750-1837), and in the Viennese medical dissertation of the Bratislava physician Heinrich Johann Nepomuk von Crantz's (1722 Roodt-sur-Eisch in Luxenburg-1799 Judenburg) student József Ferenz Staehling (* 1743) which was defended an entire generation prior to Kraškovič's doctorate.²⁰⁹⁸ Ceanz used to be the student of van Swieten and belonged to the contingent of Luxemburg physicians imported together with Kraškovič's predecessor in Varaždin, J. Battista Lalangue.

Kraškovič used Metzburg's physics-mathematical textbook. Baron Georg Ignaz Metzburg began with Newton's experiments and published his textbook in many reprints. It is therefore difficult to find out today which edition was used by Kraškovič; Kraškovič's library was subsequently sold at auction, while his legacy list of books does not have years of their printouts. Although Kraškovič did not mention him among his literature on aviation in 1810, his principal writer on gases was

precisely the Viennese professor Metzburg²⁰⁹⁹ in the book, which was also read by Franciscan Ivo Bonelli as a professor in Innsbruck, who at that time was not far from Tyrolean border of the Illyrian Provinces with its center in Ljubljana. Bonelli wrote his name in most of the then books dedicated to vacuum techniques in the Ljubljana Franciscan collection. The Ljubljana Franciscans obtained three different editions of Metzburg's lectures, each of them in seven works; barely smaller was the popularity of this reading among their neighbors, since two Metzburg collections were procured by the barons Erberg, while they were not missing even in the Ljubljana Lyceum.²¹⁰⁰

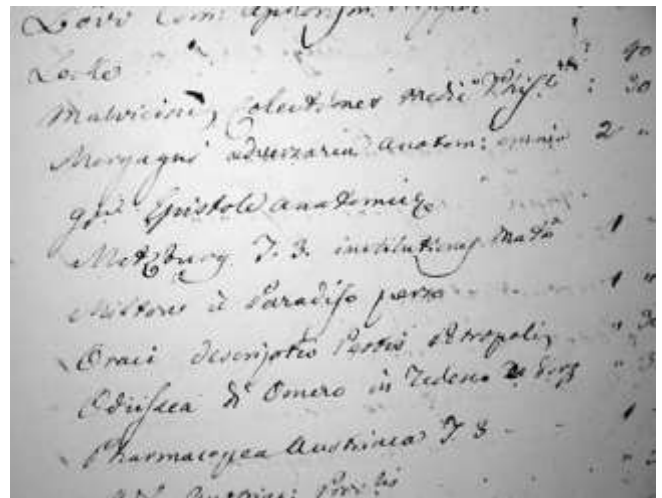

Figure 16-19: Metzburg's textbook for the exploration of vacuum and gases, listed in Kraškovič's legacy in the fourth place, counting from the bottom (HR DADU, Se. E, Fasc. VI, No. 45).

Metzburg, like Kraškovič himself, used his knowledge of vacuum techniques for balloons, although he did not fly himself because of his advanced age. Graz printmaker and meteorite explorer Alois Beckh-Widmanstätten (Aloys Joseph Franz Xaver Beckh Edler von Widmanstetten, * 1754, Graz; † 1849, Vienna), in front of some 800 spectators, launched a balloon 200 m above Vienna in later Kraškovič's home 4th district Wieden from the garden of the court secretary of the mints and mining (Hofsekretär des Münz- und Bergwesens) Anton Wenzel von Damm; the former Jesuit Ignaz Metzburg acted as

²⁰⁹⁷ Hirn Art: Medic: 1 fl; Jacquin Istruzione Chimiche 40 kr: Lalangue di Gio:Batt: 30 kr –two copies.

²⁰⁹⁸ József Ferenz Staehling, Dissertatio inauguralis chemico-medica sistens methodum generalem explorandi aquas medicatas quam... submittit in palatio universitatis Viennensis. Wien, 1772.

²⁰⁹⁹ Tomi 3 *Institutiones Mathematicae*: estimated value 1 florin (HR DADU 156, Sez. E, Fasc. VI, no. 45; Metzburg, 1793, 5: 32); Metzburg, 1769.

²¹⁰⁰ FSLJ-14 d 32; Cantor, 1901, 3: 77.

a censor of the balloon undertaking on 14 January 1784 and in the spring of 1784 after several months of indoor experiments commenced at the end of the year 1783.²¹⁰¹ Metzburg dedicated to gases the first fifty-seven pages of the fifth part of his mathematical lessons. He described in detail the vacuum balloon of Francesco Lana Terzi as the predecessor of Kraškovič's modern models Montgolfier and Jean François Pilatre de Rozier (1756; † 15 June 1785). The head of the Paris museum Pilatre de Rozier happily made a myth from the flight of his younger fellow Montgolfier, watched by the king himself. The ruler initially wanted to bring the prisoners under the balloon, but Rozier successfully applied himself for this honor, which, unfortunately, was very costly. He was overconfident about the possibility of flying under a hybrid hydrogen & warmed air balloon, which was shaken by the electrostatic discharge of the metal structure. The news of Rozier's accident was reported immediately in a comprehensive article published in the Ljubljana newspaper.²¹⁰²

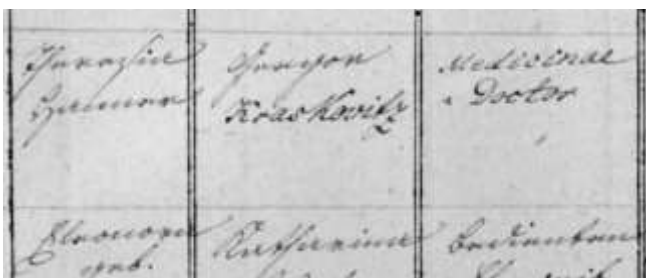

Figure 16-20: The godfather Kraškovič's signature upon the baptism of his own son Gregor Hanner at St. Stephan Platz no. 523 in Vienna on 20. 8. 1807 (Baptismal book of St. Stefan Viennese parish 1804-1807, reference code 01-104)

Jean Pierre François Blanchard (* 1753; † 1809) made more careful use of Rozier's ideas.²¹⁰³ During his flight above Vienna Blanchard also "infected" Kraškovič. Metzburg accurately described and illustrated the valves of his various vacuum pumps,²¹⁰⁴ which Kraškovič had arranged a decade later to prepare for the regulation of their pressure with hydrogen filled balloons. Just the highly developed technique of the valves and the vacuum pumps enabled the safe lifting and lowering of the

balloons, and sometimes even those achievements were not enough due to freezing at unexpectedly low temperatures and pressures at the high altitudes.

In his mathematical theses, Metzburg first started with algebra, then followed by geometry, angles, triangles and the trigonometric postulates of Hipparchus of Nicaea focusing the surfaces of the triangles. In the last thesis, the student had to draw a circle through the three points.²¹⁰⁵ Of course, in the textbook Metzburg could not easily include Boškovič's ideas from general physics, especially not into the books on applied mathematics. In the first edition of the three-grade Lyceums' textbook, the former Jesuit Metzburg published three books with logarithms in the end, but he did not mention Boškovič. In his closing volume he dealt with applied mathematics, especially geodesy, which was the parade horse of Boškovič and other Jesuits. In the second edition, a half a decade later, Metzburg added four books on mechanics, aero- and hydrodynamics with vacuum techniques, optics and astronomy. Despite the brief general introduction, he did not mention Boškovič, although, for example, he noted the experiments with the free fall of Riccioli, Grimaldi and Galileo.²¹⁰⁶



Figure 16-21: The beginning of the Air and Vacuum chapter of Metzburg's book, stored at the Franciscans in Ljubljana (Metzburg, 1793, 5 (FSLJ- 14 d 32), with the permission of Prof. Dr. Miran Špelič, OFM).

²¹⁰¹ Pär, 2011, 42.

²¹⁰² Kraškovič, 1810, 23, 56; Laibacher Zeitung (21. 7. 1785), number 29, page 3.

²¹⁰³ Metzburg, 1793, 5: 32-33.

²¹⁰⁴ Metzburg, 1793, 5: 104-105 (table of figures 2, figure 18-22).

²¹⁰⁵ Metzburg, 1773, theses 75, 79, 85, 89, 90, 100.

²¹⁰⁶ Metzburg, 1795, 4: 16.

INDEX CAPITUM.	
AEROMETRIÆ.	
	pag.
CAPUT. I. <i>Notiones generales Aerometriae.....</i>	1
CAPUT. II. <i>De antlia pneumatica.....</i>	6
CAPUT. III. <i>De gravitate, & pressione aeris.....</i>	14
CAPUT. IV. <i>De compressione aeris.....</i>	24
CAPUT. V. <i>De aequilibrio aeris cum aliis corporibus.....</i>	30
CAPUT. VI. <i>De Ventis.....</i>	36
CAPUT. VII. <i>De machinis in gravitatem aeris &c. inquirendi.....</i>	40
HYDRAULICÆ.	
CAPUT. I. <i>Notiones Generales Hydraulicæ.....</i>	58
CAPUT. II. <i>De Cursu fluminum.....</i>	75

Figure 16-22: Index of the initial chapter on air and vacuum with the second chapter (Caput) on vacuum pumps from Metzburg's book, stored at Ljubljana Franciscans' library (Metzburg, 1793, 5 (FSLJ-14 d 32), with the permission of Prof. Dr. Miran Špelič, OFM)

Bošković had a basic role in the books of Metzburg's much younger colleague Jurij Vega, who taught at the neighboring artillery school. Vega published his lectures in parallel with the second edition of Metzburg's textbook. As an experienced surveyor, Metzburg had offered much more beautiful images from his field, and Vega, as a navigational engineer and artilleryman, overtook Metzburg in the areas of hydrodynamics and ballistics. In the second edition, Metzburg published seven sections in three books, and also wrote a book on optics and mechanics, which Vega avoided. Perhaps Vega planned such a purpose as at least optical devices would also be useful for his military measurements. His principal Colloredo was persuading Vega to publish books, and perhaps he also had in mind a summary of the then vacuum techniques. Of course, Metzburg and Vega

did not deal with heat, magnetism, or electricity as separate chapters in their books, since these areas had a completely different tradition in special physics outside the applicable mathematics of Aristotle's scheme.

On 15 June 1787, Vega, along with other important scientists, watched the eclipse of the Sun from the Viennese Observatory. The court astronomer Hell was accompanied by the adjutant Triesnecker, who later allowed Kraškovič to fly from the premises of the Viennese Astronomical Observatory. There was also Gusmann, a professor of physics and mechanics with his students,²¹⁰⁷ the professor of mathematics Baron Metzburg, Jurij Vega from the bombarding school as well as a geometer and geographer Wussin. The great eclipse was also observed in Vienna by Hell's helper employed in 1753, Anton Pilgram. The observation reports were published in the newspaper after five days, while detailed measurements were discussed later in Hell's ephemeris.²¹⁰⁸ Hell used Newton's 158 cm long mirror telescope with a fifty-fold magnification. On the tube of the telescope he attached the micrometer with the thread. The beginning of the eclipse was observed at 5h 24 min and 1 s. At 6h 11 min and 36 s the eclipse was in its darkest mood. The eclipse was finally over on 6h 57 min and 28 s.

In the same building Triesnecker also observed with Dollond's²¹⁰⁹ telescope. He noticed the beginning of the eclipse 8 seconds after Hell, and its end probably 7 seconds, but surely at least 3 seconds before Hell. Metzburg watched along with them through another Dollond's telescope. He noticed the first signs of eclipse 12 seconds before Triesnecker, and the end of the eclipse 7 seconds after Triesnecker.

As a young magister of the philosophy the Jesuit Metzburg collaborated with Liesganig and Güssmann on measuring and mapping of Galicia.²¹¹⁰ On April 30, 1801 Zach in his letter to

²¹⁰⁷ Franz Güssmann (Güsmann, * 30. 9. 1741 Wolkersdorf in Lower Austria; SJ 1757 Vienna; † 28. 1. 1806 Seitenstettin).

²¹⁰⁸ *Wiener Zeitung von Mittwoch* (Wednesday) 20. 6. 1787, page 1469 (Faustmann, 1994, 94; Povšič, 1974, 70); *Fremden Blatt*, 1787; *Pressburger Zeitung*, Bratislava (Pressburg), 1787, 50: "Wien (Die Sonnenfinsternis)"; Vega, 1788, 374, 376.

²¹⁰⁹ John Dollond (10. 6. 1706, London; † 30. 11. 1761, London).

²¹¹⁰ Metzburg, 1777, 3: 45, 47, 54, 92; Güssmann, 1788, 97.

Schedius, as well as Joseph Johann Littrow and later many others severely criticized the mistakes that the (former) Jesuits made in their

Schedius.²¹¹² Zach dated the letter at Seeberg near Gotha on 23. 5. 1798 and Schedius received the letter in Pest on June 2nd, 1798.²¹¹³

Table 16-1: Books in Kraškovič's (Kraškovič) Dubrovnik heritage estimated to total amount of 119 forints

Area	Number of books
Fiction	5
Philosophy	1
Vocabularies, Grammar	5
Physics-mathematics	1
Electricity and chemistry	6
Pharmacy	5
General medicine	14
Medicine printed in the 17th century	2
Medicine printed before the 17th century	7
Venereal diseases	5
Women's diseases	2
Obstetrics	1
Fevers	1
Healing waters	3
Pests, epidemics	3
Vaccination	1
Surgery with dermatology	7
Anatomy	3
Clinical medicine	1
Veterinary	1
Medical zoology	1
Unknown	1
Total	76

measurements.²¹¹¹ Astronomer Zach was a black beast for those ex-Jesuits; among his "main friends" he counted Liesganig, Metzburg and Güssmann; both the first ones were from the devil, he claimed. Zach thus did not exactly like some Vega's colleagues who observed the solar eclipse in 1787; considering Vega himself, Zach repeatedly named Vega as his friend in his letter to

After the suppression of the Jesuit society, Metzburg became a full-time professor of mathematics at the University of Vienna in 1774, instead of Joseph Walcher, who used to write on balloons-related vacuum techniques in 1754. On 20 October 1778, Metzburg's book was declared an official textbook.²¹¹⁴ As dean, he sought to modernize the Viennese Faculty of Philosophy. Two years after his appointment as a court councilor, together with his mentor, Celovec (Klagenfurt) vicar Sigmund Hohenwart (* 1745, Celje; † 1825, Linz), he examined various Hungarian-Slovakian mines in 1798. The former Ljubljana student Hohenwart equipped one of the best physics laboratories in Klagenfurt full of vacuum devices. Later as a Bishop in Linz, he organized balloon flights that inspired Kraškovič. As a true intellectual, Kraškovič certainly did not only read scientific literature. He had in his library the *Lost Paradise* of John Milton, probably in Italian translation²¹¹⁵ or maybe even in the English original. He also obtained the works of the ancient Roman poet Horace, *Odyssey* and the book by English empiricist John Locke. Kraškovič laughed at Jean-Baptiste Willart de Grécouro's (1684-1743) jokes, and he gladly bought four British magazines *Tatler* for rich people designed by Sir Richard Steele (1672 Dublin-1729 Wales) or his later imitators, which may have served to amuse Kraškovič's patients at the waiting rooms.

The most estimated Kraškovič's book was worth 10 forints. That was the monumental work of Galen of Pergamon. All other books were evaluated to 5 forints or less, but this was primarily an antiquarian valuation of old books needed for an auction.

The books tell us a lot about the studies of a learned man. They are also very important

²¹¹¹ Zach, 1984, 79, 81.

²¹¹² Ludwig Schedius (* 20. 12. 1768, Raab (Győr); † 12. 11. 1847 Pest).

²¹¹³ Zach, 1984, 7, 47.

²¹¹⁴ Faustmann, 1994, 35

Miltone à Paradiso, estimated to 1 florin (John Milton, *Il Paradiso perduto*, translated by Giovanni Francesco Cuneo d'Ornano. Rome, 1822 (Source: Krascovich Dr. Gregorio Ventilazione d'Eredità Hanner Gregorio sua tutela, the First Instance Civil and Criminal Court in Dubrovnik (1819-1852), Ostavine, Sez. E, Fasc. VI, no. 45 (Fond HR DADU 156)).

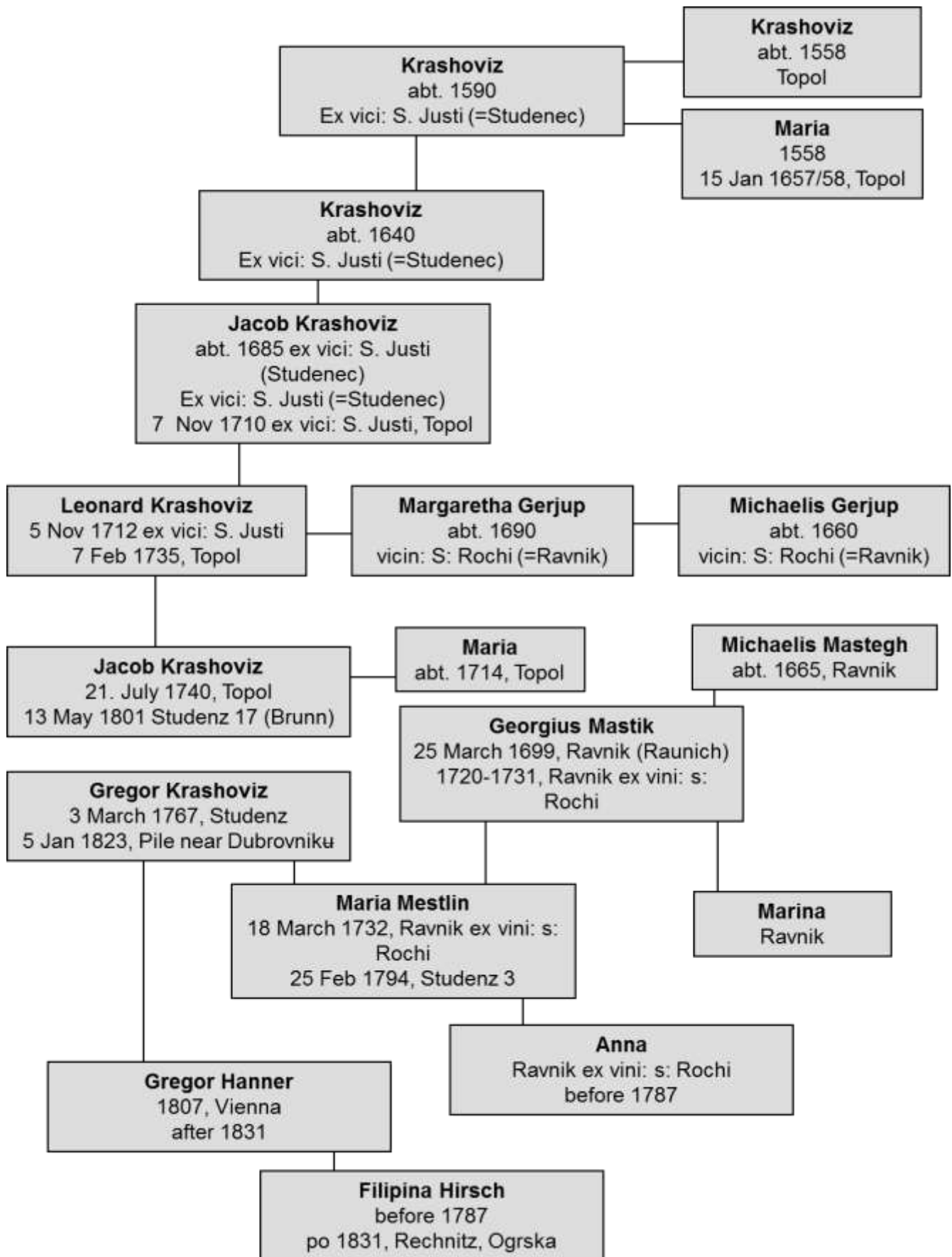

Figure 16-23: The ancestors of the first Slovenian aeronaut. Ex vici means from the vicariate, vicin means near it

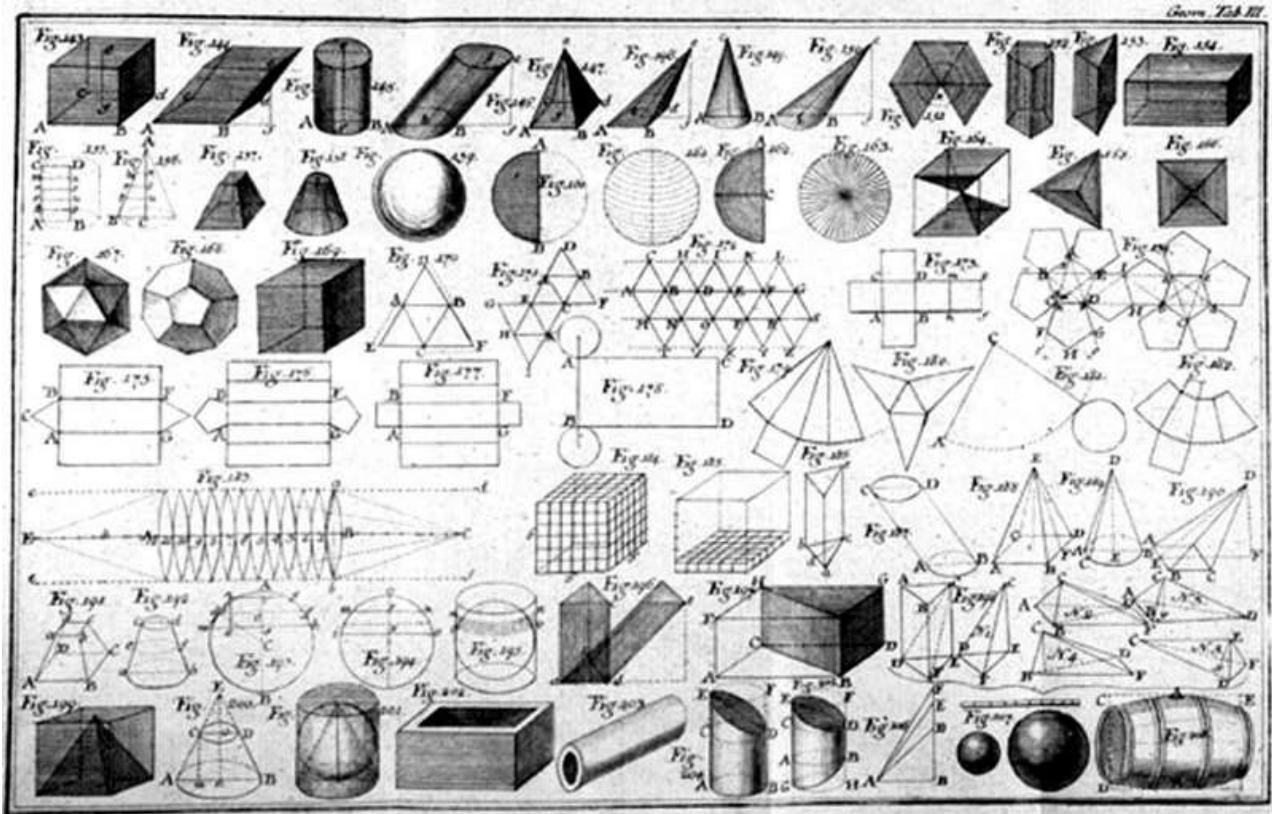

Figure 16-24: Images from the Metzburg's Manual of Vacuum Techniques from 1775, which was used by Kraškovič

illustration of Kraškovič's work in Dubrovnik. Matija Gregor Kraškovič was a famous doctor, chemist and aeronaut balloonist. Although born outside Croatia, he left an indelible mark on Croatian technical, scientific and healthcare activities in Varaždin, Kotor, Dalmatia, and especially in Dubrovnik and Mljet. Several of his works had a strong echo even beyond the boundaries of the Habsburg Monarchy, and at the end of his life he was celebrated by analyzing the causes of detonation on the island of Mljet. He explored it with a full heart, but unfortunately, he did not experience the time when the detonations had completely stopped. Kraškovič's knowledge was something special for the then Kotor, Dubrovnik and Dalmatia. He learned from the best Jesuit mathematician-naturalists of Bošković's tradition, who still lectured in Ljubljana at the time of Kraškovič's philosophical studies. Kraškovič's medical studies can be linked with the Bohemian Jesuit academic ancestors of his mentor Prochaska. On the other hand, Prochaska, as a doctor, was studying with the students of the famous Herman Boerhaave, in the atmosphere of Dutch experiments with treatment of electricity, which had a deep effect on Kraškovič's work, and

reflected the research of Kraškovič's scientific idol Alessandro Volta.

On the other hand, Kraškovič's relation to his son shows that he was a man of deep feelings. Thus, we can observe the characteristics of scientists and physicians even through the knowledge of his human virtues, which is especially important in modern times, when the private life of scientists is often forgotten.

16.2.9 Conclusion

Gregor Kraškovič was the first successful Slovenian aeronaut. Until recently numerous Carniolan neighbors wanted to own him, while his memory was fading among Slovenes.

Despite of Kraškovič's merits, the future of vacuum balloons is still uncertain. In 1843, two decades after the death of Kraškovič, almost two hundred years after Lana launched his ideas, the Frenchman Edmond Marey Monge decided to test Lana's boat. The student of Parisian Polytechnic Edmond Marey Monge was a son of the eldest daughter of the famous popular Napoleonic mathematician Gaspard Monge (1746-1818). On

August 2, 1844, Edmond Marey Monge (Louis Eduard Marey-Monge, 1807 Nuits-Saint-Georges in Eastern France-1868 Paris) tried Lana's boat under a single vacuum balloon with a slight help from the Secretary of the Aragon Academy; he spent over 25,000 francs for his beloved science; he needed to perform a lot of experiments. According to Lana's instructions, he used 0.1 mm thick sheet metal brass plate. The balloons were sealed off with two thin films of lacquered paper and he exhausted air. The device did not rise because the external air pressure compressed the ball during pumping. Lana not only neglected the influence of external pressure on the vacuum balloon; his budget was also insufficient. In addition to money, he lacked modern hardwoods and lightweight materials.

In 1854/55, the professor bishop Vittorio Angius (* 1797, Calgiari; † 1862, Turin), seriously discussed the Lana's design equipped with new, then known types of metals including aluminium. Unfortunately, Lana's ship is still awaiting a successful flight despite numerous experiments by Arthur de Bausset (* 1828, France; † 1905, New York) in Chicago between 1886 and 1900. The US Congress supported him until their enthusiasm was compromised by the advocates of brother Wright, the railway engineer Octave Chanute (* 1832; † 1910) and professor of physics Albert Francis Zahm (* 1862; † 1954). The heavier than air aircrafts replaced balloons after heavy duels.

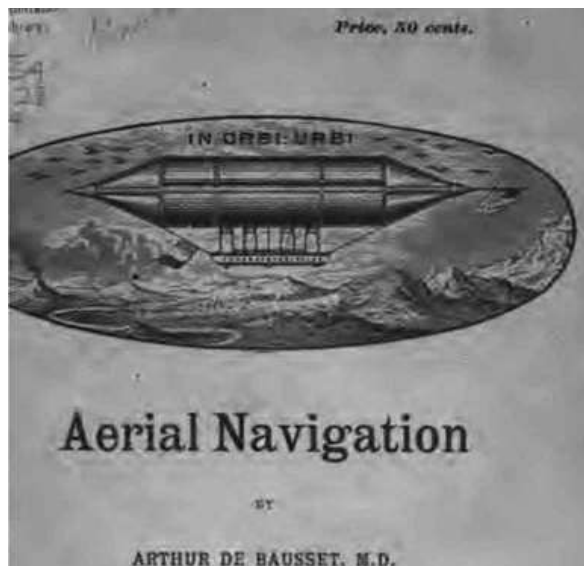
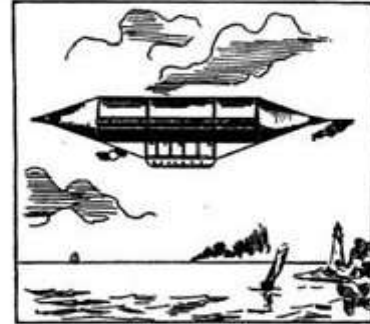

Figure 16-25: Cover page of the Arthur de Bausset's Aerial Navigation book of 1887 (Bausset, 1887)

(From the *Inter Ocean*, Chicago, Nov. 21, 1886.)

A MAMMOTH AIR-SHIP.

THE SCHEME OF A CHICAGO MAN FOR NAVIGATING THE AIR.
 Dr. A. de Bausset of this city is convinced of the practicability of a scheme to navigate the air in the manner portrayed by the accompanying cut. He is perfecting his invention, and a company has already been formed to push the enterprise. He claims that by his plan the difficulties which have attended the handling of gas balloons will be entirely removed. With ascensional force greatly increased by his as yet untried invention, he believes that his air-ship will be capable of sustaining not only its complement of machinery, but in addition a large number of passengers and considerable freight.



THE AIR-SHIP.

The inventor departs from the old method of obtaining ascensional force by means of hydrogen, and proposes to get the desired result by what he terms the vacuum theory, not heretofore tried. In regard to this point, he argues that balloons filled with hydrogen rise in the air because hydrogen

Figure 16-26: Vacuumed vessel according to Arthur de Bausset's book issued in 1887 (Bausset, 1887, 13)

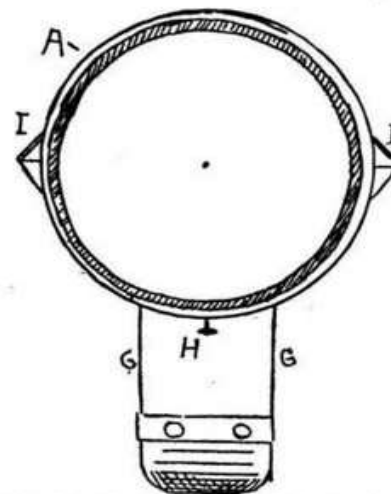

The above is a sectional view of the air-ship. A—vacuum cylinder. I—roofs. H—exhausting engines. G—wire ropes.

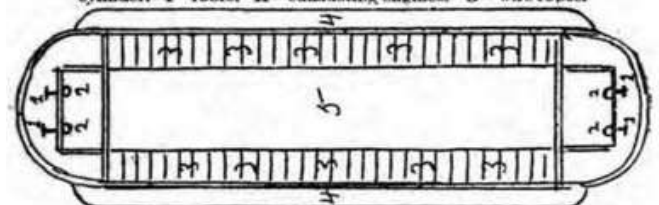

The above is merely a diagram giving some idea of the interior of the car. 1—exhausting air-screws for propulsion. 2—electric motors. 3—thirty three cabins. 4—outside promenade or platform. 5—grand salon.

Figure 16-27: Arthur de Bausset's vacuumed vessel from 1887 (Bausset, 1887, 14)

Lana's vacuum balloons are not useful even today. The mass of the steel shell far exceeds the buoyancy, insofar as the shell is at the same time the only framework. The installation of support releases the requirement for wall thickness, but unfortunately the internal frame increases the mass of the system. Even five times specifically lighter polymers with steel-like mechanical properties are too heavy frame for small vacuum balloons. The volume of the round balloon increases with the third exponent of the radius of the balloon; the mass of the frame and the force on it increase only with the second exponent of the radius. The vacuum balloon would rise at a sufficiently large radius and a sufficiently thick skeleton, when the thickness of the framework can be increased in proportion to the radius. Unfortunately, the size of such devices still exceeds the capacity of the modern industry. For a round vacuum balloon of 24 m radius with a 1 mm thick framework made of rolled steel of $8 \text{ kg} / \text{dm}^3$, the buoyancy force is equal to the weight. For a balance of 1 cm wide frame we need a round balloon with a radius of 240 m, which is slightly less than the volume of the largest Zeppelin so far built and operated. In 1910, Codelli conceived an airship in Ljubljana. It was 1 km long, with a diameter of 100 m. Its volume of 1.25 million m^3 would be eleven times smaller than a balloon with a radius of 240 m. The lift would exceed the weight of a steel frame, barely 0.9 mm thick, if a vacuum was to be used in Codelli's ship. The vacuum balloon with a $16 \text{ kg} / \text{dm}^3$ polymeric framework could fly by its radius of 4.8 m, with a volume close to half a million liters and weighing less than half of a ton; but the external pressure could damage 1 mm thick frame. Unfortunately, just the pumping out of a balloon with a radius over 50 m and a 1 cm thick polymeric frame might enable the bargain price of passengers' travel tickets.

The useful time of ordinary balloons depends on helium leakage or on heat loss in warmed air balloons. For larger vacuum balloons, the possibility of leakage is higher and pumping more expensive. The helium and hydrogen balloons do not require a solid framework, as the internal pressure can be equal to the external pressure. The upsurge of a vacuum balloon is only a fifteen point higher than that of the same spacious hydrogen balloon, which does not justify the use of an expensive and heavy frame. A vacuum balloon would only be economical if a strong balloon

framework was needed at the same time for safety or if the vacuum was used for experiments. Problems with external pressure are decreasing in higher areas of the atmosphere where the vacuum balloon would be more durable than competitors full of gas. Those lighter than air rivals were driven away from the airspace a century ago. Could the progress of vacuum technique, new materials and thin films bring a new turnaround?

demonstrating that their strength is more than sufficient for the purpose. And what a monster balloon it is that he proposes building and sailing away to the North Pole in! Look at the dimensions: 654 feet long, 144 feet in diameter—a cylinder with conical ends, all made of the steel plates riveted together and staunchly braced. Such a ship would be nearly as large as the Chicago exposition building, but the inventor says he can build it and sail it to the North Pole, or to London, or Paris, or Yeddo.



ARTHUR DE BAUSSET.

"The steel for my aero-plane," says the Doctor, "will weigh $8\frac{1}{2}$ pounds the square yard, or a total weight of 260,000 pounds, including rivets, braces, bands, etc. The contents of this cylinder will measure 273,000 cubic yards, and, as air weighs $2\frac{1}{2}$ pounds the yard, it follows that the weight of air within the vessel will be 720,000 pounds, or 460,000 pounds in excess of the weight of the cylinder. But I do not want a complete vacuum; it will be sufficient to pump out one-half or three-fourths of the air. One-half the air in the ship

Figure 16-28: Portrait of Arthur de Bausset (Bausset, 1887, 31)

Tell me what you read, and I tell you who you are. The first Slovenian balloonist is by no means an exception. As an examined scholar, he did not limit his library to purely natural sciences; He also bought the works of John Locke, who refused Descartes' doubts about the existence of a vacuum. In the white world, Kraškovič became multilingual and did not use Slovene language even as much as did A. Hallerstein, who at least took the Slovenian songbook with him on his sailings to far-away

Beijing. Kraškovič's homeland was merely his profession: he tried to follow the latest findings in the fields of vacuum techniques, chemistry and medicine, which included his basic scientific and technical activity.

Gregor Kraškovič was one of the best Mid-European physicists of his era, especially famous for his medical measurements during his aeronautic flight. He supposedly flied sixty-five times which was certainly a record for a physician of his times and one of the best results of all aeronauts. His smallpox vaccination in Varaždin was an example of pioneering work. There is no doubt about his Slovenian origin after this publication. During his work in Hungary, Gregor Kraškovič began the operative research of medical protection of workers and tried to include handicapped persons to useful work in Varaždin area while he accomplished his most extraordinary flights in Hungary. The list of his published works and reports on his deeds speak for themselves about his eminence.

Kraškovič did not fly his balloons in Kotor or Dubrovnik. Was he too old or there was not enough material support from the local magnates? Blanchard and his widow certainly performed their ballooning until their very death in their fifties and forties, therefore Kraškovič was free to do the same. Certainly, the donations of local magnates could be much better in Hungary than in south Dalmatian Kotor and Dubrovnik. Kraškovič probably even avoided to risk his life in ballooning after he became a caretaker of his son Gregor Hanner whose last name had some resemblances with Kraškovič's co-pilot Ivan Nepomuk Menner (Maenner, Manner, Männer).

17 Ether in Vacuum

17.1 Ether as a Vacuum: Cauchy's Gorizia Vacuum Theory - Introduction

Kraškovič was a practical vacuum researcher; soon after he passed away the Slovenians of Friuli borrowed the most eminent vacuum theoretician of those times. It's time to present that researcher in Slovenian soil, as he will perform a great role to our excursion in the past. Of course, he was a leading mathematician and physicist Cauchy, the greatest scientist ever living among Slovenes. He worked in Gorizia from 21 October 1836 until the middle of October 1838,²¹¹⁶ which means that he was there full of two years before the beginning of the modern vacuum firms like Heraeus and Leybold. Since Cauchy published his works for nearly half a century, more than 4% of Cauchy's discoveries belong to his Gorizian period; this is by no means a bit. In doing so, we are silently assuming that Gorizia was at least partially Slovenian at that time. Of course, something like this will not be easy to prove, since only a quarter of Gorizia folks boasted Slovenian speech as their communicative public language during those years. The statistics is sadly silent on languages the Gorizia folks used to talk at home. Even today, of course, everyone speaks well there in Slovenian own way, even though most of folks in Gorizia might be ashamed of it. God knows if Cauchy did not learn some Slovene words among the Gorizia folks; he did not have any problems with the languages, since he already learned the Italian language for his lectures in Turin.

Cauchy was born to the family of successful Parisian citizens on the eve of the French Revolution; Cauchy's father Louis-François Cauchy (* 1760; † 28 December 1848) suddenly lost his work and bread in the middle of revolutionaries. The sad experience angered Augustine-Louis Cauchy much more than his father or brother: until the end of his day, he scolded all the revolutions and revolutionaries as far the most conservative among all Parisian mathematicians. His early fears at the dawn of the

French Revolution, developed Cauchy's prominent anti-revolutionary stances.

His father moved the family from difficult hardest times which terrified his family in a safer suburban city of Arcueil, where he met Bertholet, Laplace, and especially Lagrange. Cauchy was sick half-hungry boy and preferred to sit behind his book as he disliked running around with his peers. Lagrange immediately recognized his next greatness and pointed it out to his father, Louis-François Cauchy. Lagrange advised a solid elementary education of his son. Only then he should allow him to read mathematical books. Lagrange knew what he was talking about: the successful mathematical and physical research must be based on a solid foundation and vision.



Figure 17-1: Academician Cauchy smiles kindly to his fate from the French stamp issued to commemorate the anniversary of his birth. Other important scientists and inventors of his time are: Benjamin Franklin (* 1706; † 1790), Karl Linnaeus (* 1707; † 1778), Ruđer Bošković (* 1711; † 1787), Žiga Zois (* 1747; † 1819), Johann Carl Friedrich Gauss (* 1777; † 1855), Charles Babbage (* 1792; † 1871), Janez Puhar (* 1814; † 1864), Werner von Siemens (* 1816; † 1892), Sebastian Kneip (* 1821; † 1897), Louis Pasteur (1822; † 1895), Ferdinand von Mueller (* 1825; † 1896), Marcelin Berthelot (* 1827; † 1907), Heinrich von Stephan (* 1831; † 1897), Alfred Nobel (* 1833; † 1896), Jožef Stefan (* 1835; † 1893), Robert Koch (* 1843; † 1910), zoologist Spiridon Brusina (* 1845; † 1908), geologist Gjuro Pilar (* 1846; † 1893), Janez Puh (Puh, * 1862; † 1914), Nikola Tesla (* 1856; † 1943), Rudolf Diesel (* 1858; † 1913).

²¹¹⁶ Belhoste, 1991, 178.

In 1804, Cauchy began to study mathematics according to Lagrange's advice. Next year, he enrolled in Polytechnic and took second place at exams after Biot. With Biot, they remained friends even later, although Biot and Brewster were the last advocates of Newtonian theory of light particles that no longer pleased Cauchy's peers.

Cauchy attended lectures of Lacroix, de Prony, Hachette, and most of all to Ampère's analysis, which with its optics and the theory of vacuum later influenced Cauchy research in Gorizia. After graduating from the Polytechnic, Cauchy studied the engineering at École des Ponts et Chaussées. Like many other important French scientists of this unusual era of intolerant revolutionaries, Cauchy was also primary educated as an engineer. After Napoleon's second and final fall, Cauchy realized his dream: in 1816 he became an academician. Of course, the Bourbon king Louis XVIII († 16 September 1824), the older brother of Karl X, had to put away the famous geometer and Napoleon's supporter G. Monge to get a place for Cauchy; but you should not properly examine the teeth of the donated horse. Cauchy accepted the position, although he angered many students; Monge enjoyed a great deal of love as the founder of the Polytechnic. Besides the seventy-year-old revolutionary Monge, his three years younger fellow Lazare Carnot, the godfather of revolutionary victories, was also excluded from the Academy. The similarity with modern Slovenian events is, of course, completely inadvertent.

In 1817 Biot went to Scotland; Cauchy assumed his position at the Collège de France. Cauchy was not in good relations with Poncelet and other researchers, as he supported the Jesuits against Parisian academicians. At that time, the Parisian Jesuits even had some first-class mathematicians, among them Cauchy's friend Moigno, who, however, left the Society because of the debts incurred despite of his and Cauchy's long-standing support of the invention of the Marseille based Achille Jouffroy's engine. Cauchy praised Jouffroy's invention in his reports to the Parisian Academy on 2 November 1840, 12 June 1843 and 3 August 1846.²¹¹⁷ Cauchy was interested in public transport problems already during his travels across Europe. On October 19, 1832, he suggested his improvements to Parisian academics. During that same year, the first train with a vacuum-based

steam engine was launched in France. A similar Viennese train reached Trieste only in the year of Cauchy's death.²¹¹⁸

Achille's father Marquis Claude da Jouffroy d'Abbans (* 1751; † 1832) already described steamers in 1775 and tested them on the Doubs River on the Swiss-French border in 1776 and on the Saône River in 1780 before the successful experiments of American engineer Robert Fulton (* 1765; † 1815) in Lyon and at the river Seine. Immediately after returning from Gorizia to Paris, Cauchy, certainly ardent because of a long-lasting multi-day trip in a carriage and slow boat, praised the use of the vacuum in Achille's steam-powered steam propulsion machine. Achille assembled a spinning wheel on the tail of a ship with blades resembling double swans' swords and provided better combustion in the vacuum space of the steam engine during his test drive on which he also invited Cauchy.²¹¹⁹

Unfortunately, Achille did not make money with his steamers, in the same way as his father had been unsuccessful before. His invention was successfully sold only by Fulton. At the time of Moigno's departure from the Jesuit society, Achille therefore preferred his steam engine locomotives on just opened French railways. Cauchy sharply protested during the first railway accidents, which were due to the congestion of vacuum steam engines in cases where just two locomotives tried to pull and push too many wagons.²¹²⁰ Achille placed a third rail elevated by a quarter meter between the two broad-gauge rails. There steam engine of a locomotive with a giant wheel propelled the composition.

The novelty seemed to Cauchy to be more stable drive especially during braking when the Achille vacuum system took care of the loss of steam. Of course, marketing was also the great problematic Achilles' heel while his newly achieved invention, despite Cauchy's support, soon flashed into oblivion.

After the July Revolution of 1830, Cauchy did not want to swear loyalty to the new king Louis Philip

²¹¹⁸ Belhoste, 1991, 156; Šorn, 1984, 198.

²¹¹⁹ Cauchy, C.R. 2. 11. 1840, reprint 1885, 1/5: 424, 426-427.

²¹²⁰ Cauchy, C.R. 13. 7. 1846, reprint 1897, 1/10: 69; Cauchy, C.R. 16. 11. 1846, reprint 1897, 1/10: 203.

²¹¹⁷ Belhoste, 1991, 179.

"Egalité." To the utmost loyalty to his principles, he suddenly found himself in a political vacuum. He left his family and his profitable Parisian services and went with the King Karl (Charles) X to exile. He owed to that Parisian ruler some sort of feudal infidelity, while his father and his two brothers were by no means exposed to such an extent; despite of their disapproval, they repeatedly bowed adhered to the authorities who changed very often in Paris of those days.

Of course, **François-Napoléon-Marie Moigno** (* April 15, 1804 Guéméné (Morbihan) in Brittany; SJ 2 9. 1822-Oct 1843; † 14. 7. 1884 Saint-Denis (Seine)) was baptized by the name of the Emperor Napoleon himself, which was somewhat unusual for the Jesuits. Moigno studied theology in Montrouge and successfully devoted himself to mathematics and physics. After the July Revolution of 1830, he escaped to Brieg (Brigg) in Switzerland, certainly with the help of his friend Cauchy, who hid many Jesuits in his home to prevent further violence. Endowed with an extraordinary memory, Moigno has even learned Hebrew and Arabic languages in Switzerland. In September 1833, he took over Cauchy's Torino Chair after Cauchy recommended him on 24 September 1833 together with another Jesuit La Chéze (Chaise) who took over Cauchy's editorship of *Résumés Analytiques* in Torino.²¹²¹ Moigno, unlike Cauchy, soon returned to his homeland, and in 1836 he became a professor of mathematics at the famous college of Saint Genoffe at Roue des Postes in the Latin Quarter of Paris. There he taught at the École Normale Éclésiastique for the education of Jesuit professors of mathematics and physics with the help of Cauchy.²¹²² Moigno became famous as a scholar, preacher, and writer. In 1839, he first began using the camera obscura, lighting projections and other then audiovisual devices in his lectures. Even before he left the Jesuits, he published the first part of the Differential and Integral Calculus according to Cauchy's procedures. He then traveled throughout Europe and corresponded to the Parisian L'Epoque magazine. He was a chaplain in the Lyceum of Louis the Great from 1848 to 1851. In 1850 he became editor of the journal Presse, the next year editor of journal Pays, and in 1852 he founded the famous scientific magazine

Cosmos. In 1862 he founded Le Mondes and joined the priests in St-Germain des Prés. In 1873 he became one of the Canons in Saint-Denis. He translated many scientific works of Italian and English writers into French language, while he edited *Actualités Scietifiques*. In 1849, he published a book on electric telegraph in Paris, which was in many respects a Jesuit invention. In 1869, in Paris, after the Cauchy Gorizian research, he published a book on the polarization of light and the optical activity of sugar solutions. In 1873, he published a book on molecular optics in Paris, based on Cauchy's modern optics of thin layers.

From 26 November 1830 to March 1831, Cauchy was deprived of all three of his chairs because of his absence. He remained only a Parisian academic. At first, he wanted to travel a little abroad to consolidate his health; he hoped for the rapid end of the revolution and with it the end of July Monarchy. In September 1830 he was shortly in Switzerland where he unsuccessfully tried to establish a Swiss academy with the help of the Jesuits in October 1830. In August 1831, Cauchy went to Turin, and the following year began to teach theoretical physics at the request of King of Sardinia Carl Albert himself who also did not like the new French king. Cauchy got a chair of the famous Amedeo Avogadro, the pioneer of modern molecular theory of gases. Avogadro took over the chair again after Cauchy's Moigno's departure in November 1834. In 1833, Cauchy lectured on the physics of molecules in Turin. His lecture was later published by his Torino co-worker and successor Moigno. On June 22, 1833, the main tutor of Charles V, the Baron Maxence de Damas of Toeplice invited Cauchy. In September 1833, Cauchy went to Prague to King Charles X and by October 1838 he taught mathematical and natural sciences to the royal pretender Henrique Count Chambord, Duke of Bordeaux (* 29 September 1820; † 24 August 1883 Viennese Neustadt), who was later buried next to his grandfather Charles (Karl) X in Kostanjevica above Nova Gorica. In 1834 in Prague, Bolzano invited Cauchy to discuss the definition of continuity, infinity, and empty vacuum space; Cauchy presented his discussion of the squaring of functions, which he wrote specifically for Bolzano in French language. Bolzano was then and again a few years after his meeting with Cauchy the President of the Czech

²¹²¹ Belhoste, 1991, 178, 328.

²¹²² Belhoste, 1991, 177.

Science Society in Prague, formerly led by Tobias Gruber. In 1816 and 1817 Bolzano enabled the independent development of the analysis with his modern definition of the continuity in the intermediate value theorem, which was compiled under the indirect influence of Bošković's theory of vacuum. When the new Emperor Ferdinand planned his coronation in Prague, the exiled Bourbon court suddenly ran out of space in Hradčany. In March 1836 and finally on 8 October 1836 the French court moved away from Prague and finally settled in Gorizia after a short stop in Linz and Kirchberg's Castle; there the climate seemed more favorable than in Ljubljana. Unfortunately, after a few weeks Karl X in Gorizia succumbed to the insidious cholera, which only killed him among all of his escorts. As the king of France, he came to Slovenian lands and sadly passed away soon after his arrival; he already had more than eighty years of age, and that was his third exile. By the contract, his court first settled in the Palace of Michael Coronini-Cronberg on Grafenberg with a magnificent garden. After the death of the king they moved to the palace of Counts Strassoldo. In November 1837, Cauchy was noted in the list of hundreds of people in the Bourbon service. Occasionally they lived in the Gorizia hotel Pri Treh Kronah (Tre Corone).²¹²³ Now, Cauchy had his wife and daughters with him, while in his free time he filled up the notebook with new theories and dreamed of a future glory. The Gorizia Sun mainly influenced Cauchy's research of vacuum, optics and ether for the transmission of waves of light.

17.2 Cauchy's Gorizia Vacuum

Among Cauchy's Graz and Prague associates was the physicist Hessler, who subsequently also helped Karl Robida, later professor of Jožef Stefan. In 1845, Robida began to teach mathematics on a Klagenfurt Lyceum. During the summer holidays in 1847 he went to Vienna Polytechnic to Professor Hessler. He designed complicated vacuum experiments there; Hessler kindly taught him about their interpretation.²¹²⁴ Robida needed such an experience, since he had already taken over the lectures of physics on a Klagenfurt Lyceum after Matija Ahacel who passed away in autumn of 1845. A decade earlier, Hessler worked closely

with Cauchy just before Cauchy's resettlement in Gorizia, when they were briefly together in Prague; Hessler made experiments to verify Cauchy's theories of ether and vacuum.

Dr. Ferdinand Hessler (* 23. 2. 1803 Regensburg; † 13. 10. 1865 Vienna) studied in Prague and Vienna. From 1826 to 1830 he worked at the University and Polytechnic in Graz called Technische Hochschule in Graz which was developed from Joanneum of Archduke Janez in 1811. There the first professor of popular astronomy was former Ljubljana professor Philip Neumann. From 1830 to 1835 Hessler taught mathematics and physics at the Karl-Franz University in Graz founded in 1827. From 1836 to 1838, at the time of Cauchy's service in Gorizia, Hessler was a professor of physics and applied mathematics at the University of Prague. In 1843 he achieved a chair as a professor of physics in the Viennese Polytechnic. Hessler was regular member of the Royal Czech Society of sciences in Prague and of the Natural Science Society of Halle and a correspondent member of the Viennese Academy. Thus, the naturalized "Gorizian" Cauchy was in close contact with both major Viennese physicists of the German genus, Hessler and Etingshausen, who decisively influenced the development of many Slovenian scientists. Among them were Robida, Stefan and Franc Močnik. Soon after Hessler's departure Močnik began to prepare exams for his PhD degree at the University of Graz.

On 4 April 1836, Cauchy in his letter to his former student and trustee Libri reported his research on amplification of light after its total reflection. On May 20, 1835, these predictions of his calculations were shown to Graz Professor Hessler, who confirmed them with simple and easily repeatable experiments. He bend over the black paper into rectangular triangles and placed them under the glass prism and under two smaller three-sided prisms. Then, with a needle, he penetrated the hole through the paper, which covered one of the side panels. Cauchy and Hessler noticed a picture of a candle that passed through a prism with very high intensity if the incident beam was parallel to the output surface. Cauchy did not escalate the intensity of the output beam while decreasing the angle between the incident beam and the incident surface. He was convinced that this was the first

²¹²³ Bader, 1994, 59, 61-62, 106, 290, 358.

²¹²⁴ Scheitz, 1878, 54.

discovery of a readily repeatable experiment where the interfering light added to light produces a darkness, just like the Jesuit Grimaldi taught two centuries earlier. In this new Cauchy's experiment, the totally reflected beam is better transmitted through the substance by increasing the intensity of light, which was a new argument against the emission theory of light and against Newtonian light particles. According to Cauchy's equations, the intensity of light is proportional to the square of the highest velocity of ether molecules.

On 11 April 1836, Cauchy published his letter mailed to Ampère. Cauchy discussed the propagation and reflection of light in opaque bodies near the surfaces by the equitation of Young, Poisson, Fresnel and Brewster. Cauchy explored mostly the thin surface layers of metals that became the main business of the heirs of Leybold and Heraeus a century later.

Hessler experimentally proved Cauchy's assumptions about the orthogonal direction of polarization with respect to the incident plane and the intensity of light after passing through the prisms. Hessler tabulated it as a "scattering relation" in his textbook about physics.²¹²⁵ So, Hessler and Cauchy based modern thin-film optics as an important part of the vacuum technique of Leybold, Heraeus and, of course, also of Slovenian companies.

17.3 Cauchy's Thin Layer Optics of Stefan's Teacher Robida

On 18 May 1836, Cauchy investigated the elliptical polarization of light in metals; he linked his ideas with Brewster's experiments.²¹²⁶ Cauchy's findings have become the basis of modern optics of thin metal layers. Cauchy's research had a strong influence even on Robida's optics from 1860, 1861 and 1862, which Robida began to publish seven years after he taught mathematics and physics to J. Stefan in his Matura year of the Klagenfurt Grammar School. Robida's optics was, in many ways, a continuation of Cauchy's optics, as Robida calculated his velocity of light for the supposed longitudinal component of a wave.²¹²⁷

According to Robida, the transversal part of the wave is weaker than the longitudinal and is soon damped because it cannot pass through a vacuum. Robida did not write the relationship between the two types of waves, although in 1829 and 1831 in Paris Simeon Denis Poisson (* 1781; † 1840) published that the molecules' amplitudes in the direction of propagation of wave are four times greater than the amplitude perpendicular to it. In 1848 the measurements of Wilhelm Wertheim (* 1815; † 1861) suggested up to three times greater ratio depending on the type of substance.²¹²⁸ The Viennese Jew Wertheim became an examiner of candidates in the Parisian Polytechnic in 1855.

The idea of two types of waves was used by many researchers in various branches of physics. In 1817 Young introduced transversal waves of light only as companions of longitudinal waves. A similar description was adopted by both Robida and Šubic. Everybody thought that the longitudinal components of light cannot be seen with the human eyes. Nevertheless, longitudinal waves could not be easily eliminated even after the prevailing transversal theory in the 19th century. Longitudinal waves of light that the eye does not perceive were described by Augustin Fresnel (* 1788; † 1827) and André-Marie Ampère (* 1775; † 1836) on 30 August 1816, by Herman Helmholtz (* 1821; † 1894), Konrad Wilhelm Röntgen (* 1845; † 1923) and others.²¹²⁹ Šubic used a different model to describe electric waves;²¹³⁰ with it, the secondary transverse component can be detected as the Joule's heat, which warms up the conductor.

Robida later changed his opinion that the ocular retina can detect only the transverse part of the waves of light. The longitudinal part of the oscillation also affects the retina of Robida's eye. The change may have been related to the original incompatibility of Robida's theory with his contemporary mainstream optics.²¹³¹ That is why he has also given to his longitudinal impulse a role in spreading of disorder which manifests itself as light. He assumed that the wave propagates in the form of a truncated cone. The axis of the cone determines the longitudinal component, and the radius of the larger base of the cone determines the

²¹²⁵ Hessler, 1852, XLIV-XLV (table XX).

²¹²⁶ Cauchy, 1884, 1/4: 20-21, 30, 32, 312, 331.

²¹²⁷ Mladjenović, 1985, 166; Robida, 1860, 21, 23.

²¹²⁸ Robida, 1860; Rosenberger, 1890, 248-249.

²¹²⁹ Robida, 1860, 23, 25; Šubic, 1874, 460; Maite, 234.

²¹³⁰ Šubic, 1862, 142.

²¹³¹ Robida, 1861, 7-9; Robida, 1860, 23, 3.

transversal component of the wave.²¹³² Robida developed his equation describing the changing of the refractive index with the density of the substance by the Parisian professors Dominique François Jean Arago (* 1786; † 1853) and Jean-Baptiste Biot (* 1774; † 1862),²¹³³ but not according to Cauchy.

In his last chapters Robida described polarization, which was discovered by French Étienne Louis Malus (* 1775; † 1812) as the main theory of particles of light at the beginning of the century. First, he described the structure of the Iceland spar's birefringence, which Erasmus Bartholin (* 1625; † 1698) had already tried to clarify with his experiments two hundred years earlier. Robida determined the distance between the molecules in various directions. He calculated the regular and extraordinary beam pulses according to the theorem on the preservation of the quantity of fluid.²¹³⁴ He specifically considered four directions of the incident beam relative to the axes of crystal.

In his Chapter 21, Robida described polarization with reflection and a simple refraction. The transverse fluctuation of the reflected rays is also polarized, as the only allowed oscillations are perpendicular to the plane of the reflection. The Kiel professor Christian Heinrich Pfaff (* 1773; † 1852) measured his polarization ascending by the greater angle of incidence. Scotsman David Brewster showed that the greatest possible angle between the refracted and the reflected beam is equal to 90° upon the total polarization.²¹³⁵

Robida also described polarization in the Birefringent Iceland spar crystal, where the light fluctuates in two rectangular directions.²¹³⁶ With the refractive index Robida has tried to explain the properties of the molecules of matter and vacuum. He considered that the speed of light does not depend on the wavelength, but only on the intensity of the disturbance that triggers the oscillation, that is, the amplitude of the oscillations of the molecules.

²¹³² Robida, 1861, 7-9.

²¹³³ Robida, 1861, 11, 17; Robida, 1862, 2.

²¹³⁴ Robida, 1862, 13.

²¹³⁵ Robida, 1862, 13.

²¹³⁶ Robida, 1862, 22nd. paragraph, like Maxwell's description of electromagnetic waves in the year 1873.

In the 17th century, the double refraction (birefringence) and the corresponding polarization was initially attributed only to the Iceland spar. In 1811, Malus described these two characteristics of the light for other substances, and even for all phenomena where the light beam pulse separated to its components after refraction. Robida described the double refraction with the interaction of the luminous impulse and the attractive force between the molecules.

Although Robida investigated the light and especially the polarization with Cauchy's theory of vacuum and atoms, Robida mentioned Cauchy's connection between the velocity and the wavelength of the waves studied in Cauchy's *Mémoire sur la dispersion de la lumière* (1830) and the corresponding Hessler's table from Hessler's textbook only in Robida's history of physics,²¹³⁷ but not in subsequent Robida's papers about optics.

17.4 The Vacuum in Cauchy's Optics

Cauchy began to research the dispersion as early as 1835 and 1836 in Prague. The sunny Gorizia areas had then a beneficial influence on his thinking about light, ether and vacuum. As early as January 1836, Cauchy's distribution of light in an isotropic ether was compared with Fraunhofer's measurements of refractive indexes. In the last few weeks before his arrival in Gorizia, Cauchy began researching the dispersion of light while he was studying the properties of a vacuum full of molecules of ether. In a satisfactory way he adjusted the famous Bošković's force, which was until those times the main subject of the study of Gorizia and Ljubljana physicists. In the Cauchy's model, at higher distances, the ether molecules were attracted by the force of gravity that diminishes with the inverse value of the square of the distance. At smaller distances, Bošković's assumptions about repelling of molecules were taken into consideration, which were inversely proportional to the fourth exponent of distance. Cauchy's ether is necessarily very dense system of molecules; its density is greatest in a vacuum without dispersion and smaller in bodies with a dispersion. He published a general equation of motion in a uniaxial system of molecules and

²¹³⁷ Robida, 1854, 28; Hessler, 1852, XXXII-XLV.

studied propagation of waves in an isotropic and uniaxial system.²¹³⁸

In Gorizia, Cauchy conceived new reflections on optics based on Jamin's studies of reflection and Fraunhofer's researches of dispersion. On December 15, 1837 Cauchy wrote to the Jesuit Moigno in Paris about an orthogonal polarization; he was forced to change his opinion and accept Fresnel's assumption of the vibrations of molecules perpendicular to the plane of polarization. In this Gorizia paper, under the title *Lois de propagation de la lumière dans le vide et dans les milieux qui ne dispersent pas les couleurs*, Cauchy discussed the spread of light in a vacuum and in metals; this is one of the rare papers which was also preserved in Cauchy's manuscripts.²¹³⁹ Thus, Cauchy devoted himself to the research of the properties of the vacuum in Gorizia. At the same time, he examined among them Gorizia folks the behaviour of light on the surface of metals and of other opaque materials. A few days before his departure to Gorizia, on 3. 10. 1836, he wrote to Libri in Paris in a great anger due to Arago's criticism, published on August 10, 1836. Arago rejected Cauchy's presumption of null dispersion in a vacuum; Cauchy's political views also annoyed the liberal Arago. Of course, Cauchy returned the insult to Arago, and he ensured his readers that physicists did not discover phenomena which Arago's predicted, that therefore would not bring novelties to science. Cauchy did not like Arago, primarily because after the initial support of Fresnel optics Arago later deflected the theory of transversal waves and even used the emission system of Newtonian optics.²¹⁴⁰ Thus, together with Parisian academic papers, the news about the Parisian academic quarrels reached Cauchy in Prague and later to Gorizia only with a one-month delay. With Cauchy, Gorizia became the center of physical and mathematical research worldwide for two full years.

In 1838 at the Parisian Academy, Cauchy published two papers about the similarities between plane waves and waves that cause polarization and double refraction of the light. Immediately after returning from Gorizia to Paris, on October 29, 1838, Cauchy reported about the

vibrations of the ether-vacuum in the homogenous environment or in a system of two medias where the light is spreading in parallel with the axis or perpendicular to them. On 28 October 1839, he reported on pressures and tensions in the dual system of molecules of two different substances with mutual attraction and reflection based on Mariotte's Law about the relative pressure of gas and on Ampère's ideas about heat and light. Cauchy imagined his molecules as polygons consisting of three or more atoms, preferably as octahedrons with six atoms linked to Avogadro's and Ampère's new two-atomic gas molecules. In the vacuum atoms of the same elements rejected each other and occupy the opposite sites in the polygonal molecule. Of course, given the lack of results of measurements, atoms of the same species could even be attracted to one another. Cauchy explained the modification of the molecular components and variations observed by Mitcherlich when he was changing the angles of the crystal expanded due to heat. The form of molecules is thus not permanent, as the crystal is a system of material points almost in Bošković's sense. Due to the large enthalpy of vaporization and enthalpy of fusion, Cauchy assumed that the heat of solid bodies depends only on the vibrations of molecules around the center of gravity while in individual gases, individual molecules can rotate themselves.²¹⁴¹ He thus announced his new kind of reflections on the degrees of freedom that became the basis of the later Boltzmann's statistical mechanics and Stefan's extended use of the hydrodynamic equations.

On November 29, 1838, Cauchy described the spread of surface (plain) waves in a system of molecules with the attraction and reflection at very small distances while the polarization and double refraction were also in charge. He developed a very simple process, from which immediately followed the formula for surface waves. A similar equation was derived by Cauchy's Viennese colleague the physicist Ettingshausen for polarization in transparent bodies based on Cauchy's Gorizian paper published in Paris on 29 October 1837.²¹⁴² The sunny Gorizia has always repeatedly godfathered the interesting predictions of optics and the theory of vacuum. Ettingshausen has explained bright and dark lines in the spectrum of the Sun and other sources of light by the wave

²¹³⁸ Belhoste, 1991, 169-170.

²¹³⁹ Belhoste, 1991, 171-172, 280; Archive of Cauchy's

grandniece madame Pomyers in her residence in Ivoy-le-pré.

²¹⁴⁰ Cauchy, 1884, 1/4: 36-38, 190.

²¹⁴¹ Cauchy, 1884, 1/4:516, 517, 522.

²¹⁴² Cauchy, 1884, 1/4: 99, 103, 106.

theory of light, while he reported to Cauchy about his results. A few years later, Cauchy published a similar theory of ether and vacuum at the Parisian Academy on 22 April 1839.²¹⁴³

substances and described the motion of the beam in a vacuum.²¹⁴⁶ When traveling through the universe, the earth was carrying with it a considerable mass of ether and caused aberration.²¹⁴⁷

The later Stefan's teacher Baron **Andreas von Ettingshausen** (* 1796; † 1878) collaborated with the "temporary" Gorizian Cauchy. Ettingshausen arrived in Vienna with his father who served as an officer in Habsburgian army. He studied philosophy, law and artillery at Bombardierschule, where Vega lectured few years before Ettingshausen's matriculation. Vega was followed by professor Ramutha,²¹⁴⁴ the later professor of mathematics in Novo Mesto. In 1817, Ettingshausen became an associate professor of mathematics at the University of Innsbruck. From 1821 to 1835, Ettingshausen was a professor of higher mathematics at the University of Vienna; then he replaced his chair of mathematics for the chair of physics, applied mathematics and mechanics while in 1826 he was already the leading Viennese researcher of atoms and vacuum. In Vienna, Ettingshausen and Baumgartner began to publish a highly regarded physics-mathematical magazine as the first of its kind in Vienna. On 4 March 1840, Ettingshausen was the first in the world to take a photo through a microscope by Daguerre's process. In 1852 he became a professor of engineering sciences at the Viennese Polytechnic Institute. In 1853 he reorganized the new Doppler's Institute of Physics at the University of Vienna with high vacuum experiments, although he beforehand dismissed Doppler with Petzval's help. Ettingshausen founded the Viennese Academy of Sciences and served there as general secretary from 1847 to 1850. In 1862 he was the rector of the University of Vienna. Unfortunately, he soon began to suffer from illness, and he had to choose Stefan as his successor at the Institute of physics.)



Figure 17-2: Cauchy's collaborator the Viennese physicist and vacuumist Andreas von Ettingshausen (* 25. 11. 1796 Heidelberg; † 25. 5. 1878 Vienna).

Cauchy persisted in Gorizia until the royal pretender come to his age and Cauchy subsequently gained the baron title according to his ambitions. After returning to Paris, it took quite a while until he regained his previous academic chairs and honors. He was supported by Biot and Arago, but he was opposed by Poisson. Immediately upon returning to Paris, on 22 April 1839, Cauchy refused Poisson's criticism that Cauchy's equations describe well the passage of light from the air to water, but rather clumsy the pathways from air to glass.²¹⁴⁸

Laplace once prophesied the great future of the little fish Poisson, while Lagrange did the same to his domestic friend Cauchy. Unfortunately, no one announced Poisson and Cauchy's grievous disputes.

On 17 June 1839, the Irishman James MacCullagh (* 24. 10. 1809 Landahaussy; † 24. 10. 1847 Dublin) intervened in those Parisian quarrels; in a

Immediately after leaving Gorizia on 10 December 1838, Cauchy, imagined the oscillation of molecules around the equilibrium position that he described as parallel ellipse.²¹⁴⁵ He completed Descartes' law of refraction for the case of opaque

²¹⁴³ Cauchy, 1884, 1/4: 330.

²¹⁴⁴ Aquinas Ramutha (* 1787; † 1861).

²¹⁴⁵ Cauchy, 1884, 1/4: 114, 121.

²¹⁴⁶ Cauchy, 1884, 1/4: 137, 141.

²¹⁴⁷ Cauchy, 1884, 1/4: 191.

²¹⁴⁸ Cauchy, 1884, 1/4: 322.

letter to Arago, he demanded his own priority in discovering some Cauchy's equations for calculating the intensity, changing of the phase, and polarization of light reflected from metals. Both Cauchy and MacCullagh particularly considered Brewster's experiments, although Brewster rejected the wave theory of light. MacCullagh liked to clash in many circumstances in disputes for his pioneering championship; it seemed that he always entered the battlefield of a certain promising scientific problem for the thickness of a hair too late. MacCullagh collaborated with his fellow Hamilton in his optical research, and in 1840, in Turin, in his friend Babbage's apartment, MacCullagh met Cauchy's former student Luigi Federico Menabrea (4 September 1809 – 24 May 1896) later count and 1st marquis of Valdora as Italian general, statesman and PM. MacCullagh also met Cauchy's opponent from the Turin university the astronomer Jean Plana (Giovanni Antonio Amedeo, 1781-1864). Babbage visited Carniola to get some Proteus on that occasion, but MacCullagh was probably not with him there.



Figure 17-3: Cauchy's villa in the suburbs of Paris, where he died two decades after returning from Gorizia.

Cauchy proved that MacCullagh used a different equation for the index of refraction of metals and their thin surface layers. Immediately after leaving Gorizia, on 28 April 1839, Cauchy published a study of the six equations of motion and the infinitely small movements of two molecular systems that penetrate each other. He described an

isolated ether-like vacuum in the environment with a velocity of longitudinal waves equal to zero as he had been doing nine years earlier. In the second version of his theory, he was so much committed to his mathematics that he unlimitedly believed in the future measurement of longitudinal waves by changing the density of the ether, possibly in connection with heat, as Cauchy noted in his letter mailed to Ampère on February 19, 1836. That Cauchy's hope was close to Robida's, Helmholtz, Hertz and Röntgen's later thoughts. It seems that they were wrong, anyway.

Christiaan Huygens was among the first to conceive ether as a gas of light. Cauchy's earth dragged ether behind itself on its way around the Sun. Unfortunately, this made it difficult to understand the aberration which James Bradley measured in 1728. Due to the immeasurability of never detected longitudinal waves in the ether-vacuum, Cauchy assumed the negative compressibility of the ether-vacuum. Unfortunately, George Green (1793–1841 Nottingham) proved the instability of such an ether. Longitudinal waves cannot spread through a vacuum, as there is nothing that could be thinned or thickened in a void.

Like Robida, Cauchy considered the heat as vibrational movement, which can spread in a vacuum, that is, in an isolated ether. According to Ampère, the equation which describes the transfer of heat is of second order in time and of fourth order in terms of coordinates, like Cauchy's vibrations by varying the density of the ether which measured the degree of vacuum. Fourier's general equation designed for his describing of the heat allowed the total polarization. That's the way how astronomer Herschel could have conceived a light that travels without waves of heat in the vacuum of the interstellar space or through other completely transparent and isotropic bodies.

The problem of mathematical predictions of the undetectable longitudinal waves already appeared from Cauchy's description of deformation in a crystal calculated by tensors in 1822. On January 27, 1823, Cauchy investigated the movement of two liquids put one above the other, where only one of them was compressible. At the contact junction points of both liquids he used a wave equation from his wave theory, for which he

received the award of the Parisian Academy of Sciences in 1815.

On 17 November 1823, Cauchy reported to the Parisian Academy of the influence of the attractive force of molecules on the motion of waves. The viscosity of liquids causes the attraction of molecules at small distances in the same way as in Bošković's theory of atoms and vacuum. In 1827, Cauchy spoke to the Parisian academicians about Navier's equations of motion, which he generalized for anisotropic solid matter in the following year, independently of simultaneous Poisson's similar works. On 4 May 1829, Cauchy summarized his research on the equilibrium and movement of fluids. On 21 July 1829, in a letter to Libri, he described a torsion of elastic bars, which Savart had just confirmed by his experiments.²¹⁴⁹

Cauchy's diminution of the velocity of longitudinal waves towards zero or its escalation towards infinity was, of course, an urgent desperate search for a principle from which the equation of motion could be derived. This succeeded only in MacCullagh's work. MacCullagh imagined a solid substance with a flexible energy which only depends on the rotation. Although he wrote the idea already in his run-up with Cauchy in 1839, it was only published after MacCullagh's suicide nine years later. Of course, the idea was far too wild that it could be accepted by most of serious mainstream scientists.

Stokes described the ether as a plastic solid substance, which becomes flexible by rapid motion. Cauchy has imagined his molecules of ether as much smaller than their mutual distance; the speed of Cauchy's light depended solely on the composition of the bodies. In the confusion caused by insufficient experiments, Cauchy subsequently published two different theories of crystal optics, three different models of reflections, and three different theories of elasticity, ether and vacuum in the years 1830, 1836, and 1839. All his ideas gave at least approximately exact equations. They opposed each other because of their inaccurate boundary conditions and the unrealistic values of constants involved. Later, he abandoned the assumption of the same density of the ether in vacuum and in bodies with idea of the pressure of molecules proportional to the third exponent of the density of ether. Those were just arrows launched in the fog full of darkness. Only Fresnel's laws of

reflection were measured accurately; Cauchy had to guess as much accurately as possible without serious measurements of the orientation of the plane of oscillation with respect to the plane of polarization, the density and elasticity of the ether-vacuum. Thus, the foundations of a modern vacuum theory were developed on relatively damp shaky foundations under the hot Gorizia sun.

Cauchy initially assumed a parallel plane of oscillation, and later, a perpendicular plane of oscillation and a plane of polarization. At the same time, he developed three variants of boundary conditions for the rays of light passing from one environment to another. Of course, he had the very right point once and again, since he was such a kind of important person who always has the right solution at hand and is always confident in himself; especially when disturbed with his own errors. Cauchy's idea of longitudinal heat wave in the ether from 1837 and 1842 was brutally rejected by Biot in *Journal des Savants*; so, Cauchy even abandoned the printing of his work and did not announce any of his researches in optics until the revolutionary year of 1848.²¹⁵⁰

17.5 Conclusion

Cauchy was a king, one of three French kings who settled in sunny Gorizia of those times: the formally exiled king, his royal son and the king of mathematicians. Even Galois admitted that Cauchy was the only one of that era, who knew how mathematics should be done despite of the fact that Galois was an evident Cauchy's political opponent and Cauchy treated Galois's manuscript very unjustly. Cauchy's conservative politics influenced his mathematics just like Galois' revolutionary unsteady life shaped his ideas. The genial Irish friends MacCullagh and Hamilton killed themselves or drank too much, which was again the fatal influence on their genial mathematics. Cauchy staid cool and deeply conservative upstart focused on his title of baron.

The long-term stay in sunny Gorizia for two years particularly stimulated Cauchy's interest in optics and vacuum. Already in Prague, Cauchy wrote a lot about ether in space; he used primarily the ideas

²¹⁴⁹ Belhoste, 1991, 297, 302, 324-325.

²¹⁵⁰ Cauchy, 1884, 1/4: 333, 343, 431, 493, 495; Rosenberger, 1890, 311, 314; Mladjenović, 1985, 145-146; Belhoste, 1991, 200.

of his teacher Ampère. He continued with his reflections under a clear Gorizia sky and then published them well after his return from Gorizia.²¹⁵¹

With Cauchy's work in Gorizia, the Slovene lands surpassed most of the Central European space of discussions about vacuum. Parallel with Cauchy's work, the first successful Central European vacuum companies Leybold and Heraeus based their success on vacuum, ether and optics of thin metal layers. The theory and practice, the academic and profitable applied thinking about the vacuum have thus evolved in parallel and yet each as a separate one; from Boyle's and Guericke's times, the theoretical and experimental research of vacuum never again joined in the same networks as they were no longer developed by the same people. Almost nobody could be the successful experimentalist and a great mathematician at the same time as Plücker was, not to speak about the technological applications. The theory and experiment have become the subject of two different professional occupations of physicists; the theorists of vacuum were increasingly separated from researchers of vacuum technology. Cauchy's concept of vacuum as ether challenged Crookes' ether full of forth aggregate state filaments later nicknamed as plasma. Finally, Cauchy's concept of vacuum and ether suffered a severe blow with Einstein's theory designed without an ether.

²¹⁵¹ Cauchy, 1884, 1/4: 483-484.

18 Industrial Uses of Vacuum Technologies: Modern Electronics

18.1 Cathode Ray Tubes's Electronics among Slovenes

Nicolò Vlacovich was of Slavic origin according to his surname. He was born in Vis or in the fishing village of Portira (Postira) on the northern coast of the island of Brač in 1832 - at the place where the Croatian poet Vladimir Nazor was born a century later. Vlacovich was a Slavic mountains' leaf from the islands. During his studies at the University of Vienna he worked in collaboration with his few years younger colleague later professor Jožef Stefan at the Ettingshausen's Institute of Physics. While studying at the University of Vienna, Vlacovich researched at the Ettingshausen's Institute of Physics, where, five years after Vlacovich's departure to Koper, Jožef Stefan became Ettingshausen's co-director and later successor.

J. Pöschl's successor Albert Ettingshausen, Andreas Ettingshausen's grandson, proudly recalled Tesla's former schooling in their institution at the rector's speech in Graz Polytechnics later in 1893.

Stefan was one of the students (Zögling) at the Viennese Physical Institute, where he showed "extraordinary talent". On August 5, 1858, he was confirmed as a teacher of mathematics and physics. In 1860, he lectured on the Higher Real school of 1st Viennese department called Innere Stadt at Bauernmarkt, while at the same time he was assistant professor of higher physics at the University of Vienna. Vlacovich was also a researcher at the Physics Institute until he was confirmed as a teacher of mathematics and physics a month and a half after his younger colleague Stefan on 25 September 1858. As the substitute (suplent) teacher lecturing from 5 October 1858 until the end of the school year 1862/63, he taught physics at a higher gymnasium in Koper,²¹⁵² where he was also a curator of the cabinet of physics.

²¹⁵² OSTA, 1, 26. 1. 1863, 9; Vaniček, 1860; Dassenbacher, 1868-1869.

In the first years in Koper and Trieste, professor Vlacovich developed a rich scientific activity. He particularly enjoyed by experiments with electricity, since the Trieste port was developed into an important center of physics and mathematics. Among the most important achievements in researching high-frequency discharges on today's Slovenian soil is Vlacovich's discussion on the duration of the electric spark, published in Koper in 1863. He continued his experiments published in previous year in Italy and Vienna.

In 1863/64 Vlacovich gained a place in the urban higher real school of the Civic Scuola Reale Superiore Autonoma in Trieste, which later developed into the modern Oberdan Lyceum. Vlacovich was director of the high school in Trieste from 1863 until his death in 1890. Bartolomeo Biasoletto²¹⁵³ taught physics in Trieste before Vlacovich. For more than two decades, Vlacovich directed the development of the Trieste education, since he was still professor of physics and director in the school year 1884/85. The Real school in Trieste was initially lower, and then it was complemented by a higher sixth grade. In 1865/66, Vlacovich also lectured in physics five hours per week in the second year after Schabus's textbook published in 1859. In 1871/72, he taught physics only in the sixth grade.

Already upon his arrival in Trieste in 1863/64, Vlacovich was a member of the Society of Natural Sciences in Augusta in Sicilian Syracuse and a member of the Agricultural Society in Gorizia. In the first years in Trieste, Vlacovich developed a rich scientific activity, and his experiments with electricity were especially awesome.

In addition to Vlacovich, the report of the Real school in Trieste was supplemented by other physical contributions. In 1875, G. Derase described procedures for determining the refractive index in solids, liquids and gases. In 1871, M. Lovrich, a supplied teacher of geometry, investigated strings vibration, clustered between

²¹⁵³ Twenty-year-old native of Istria Biasoletto graduated from pharmacy school in Vienna in the year 1814 and in the year 1823 he received his doctorate from natural science in Padua. In the year 1828 he established the first botanical garden in Trieste, and in the year 1838 he visited Istria, Montenegro and Dalmatia; his vision of the inhabitants of those areas was published in his book three years later.

Cauchy left Gorizia when **Nicolò Vlacovich** was only a kid in nearby Adriatic island somewhat south. Nicolò Vlacovich learned his physics in the institute of Cauchy's collaborator von Ettingshausen; Cauchy's deep conservatism was melted there a little bit. Nikola Vlahović (Nicolò Vlacovich) from the island of Brač or Vis studied at Ettingshausen's Viennese Physical Institute, where he met three years younger Stefan. On 5 October 1858, he was installed at the Higher Gymnasium in Koper, where he taught physics until the end of the school year 1862/63. During this time, he published his first experimental research on discharges in the most important Italian and Hapsburgian physics journals. He was then a physicist for more than two decades, and later a director at the Scuola Reale Superiore in Trieste. At least in 1863/64 he was a correspondent member of the Society of Natural Sciences in Augusta and the Agricultural Society in Gorizia. He published all his papers in the Italian language. Nicolò's older brother was a Paduan professor of anatomy Giampaolo Vlacovich (23. 10. 1825 Vis (Lissa)-11. 1. 1899 Padua). Nicolò and Giampaolo Vlacovich were both members of the *Società Italiana di scienze naturali* in Vicenza where they published about microscopy and about the zinc in Robert Wilhelm Bunsen's pile in 1868. Nicolò Vlacovich was also a member of *Società agraria di Trieste*.²¹⁵⁴ Nicolò was active lecturer of the Minerva society with themes of natural sciences like 'On the fluorescence (Delle fluorescenza)', 'On the manufacture of the ice (Sulla fabbricazione del ghiaccio)', 'On the electric clocks (Sugli orologi elettrici)', etc. The other Nicolò Vidacovich also collaborated in the leadership Minerva society as a close friend and German language translator of James Joyce. Nicolò Vidacovich (Vida-Covi, 1875 Trieste-1934) also served as director of Minerva Society of Trieste in 1872 and 1905-1909. Società di Minerva published the journal *Archeografo Triestino*. Nicolò Vlacovich died in 1890.²¹⁵⁵ Nicolò Vlacovich's best student in Koper was Antonio Pizzarello (1846 Koper-1933) until Vlacovich left Koper

for Trieste in autumn 1863. The Grammar school of Koper acquired textbooks of Vlacovich and his student Pizzarello, both published in 1880. Antonio Pizzarello graduated with Matura in Koper Grammar school under the presidency of Trieste state grammar school director Venceslao Giuseppe Menzel in August 1864. Among his classmates was the archaeologist Geminiano Pellegrini (* 1845 Koper) who also became a professor in Italy. Their professor of mathematics and physics in final class was Vlacovich's replacement from the Higher real school of Split (supplente, Scuola Reale Superiore di Spalato) Antonio Lorenzo Gossetti (Gosselti, Zadar-1895 Trieste), author of paper about the conservation of forces (*Cenni intorno alla conservazione della forza, Programma del Ginnasio comunale superiore di Trieste pubblicato alla fine dell'anno scolastico 1870-1871*) in Trieste in 1871, the doctor of mathematics, civil engineer and architect and later director in Trieste named in 1883. The other Antonio Pizzarello (* 1869 Koper) graduated with Matura in Koper Grammar school and became the counsellor of finances in Sarajevo of recently dominated Habsburg Bosnia. A. Pizzarello senior fought in Garibaldi's Risorgimento units in Mentana on November 3, 1867, and married Koper native Nicolina Gambini. Their son Ugo von Pizzarello (1877 Macerata-1955) studied physics-mathematics and became the highly decorated general of alpine units. Nicolina Gambini was the aunt of Pio Riego Gambini (1893-1915) the leader of the Istrian Mazzini's fans and the founder of Fascio Giovanile Istriano in 1913. Antonio Pizzarello (* 1846 Koper) graduated in Paduan University in 1868 and became a professor of 2nd class in 1872. The Habsburgians exiled Antonio Pizzarello (* 1846 Koper) after a political process in 1879, when he was already a professor of Lyceum of Macerata in Italy where he researched kinetic properties of atoms in gases. Antonio Pizzarello and Marangoni unsuccessfully tried to get a chair of physics in the university of Modena under the commission of Pietro Blaserna, Antonio Roiti, Andrea Naccari, Emilio Villari and Adolfo Bartoli in 1888. Antonio Pizzarello got a golden prize for his physics instrument in Torino Exposition (Esposizione) Nazionale in April-October 1898. Marconi already exhibited there his radio, but Tesla did not. Antonio Pizzarello's instrument was a clever modification of Torricellian, Helmholtz Giuseppe Martinotti of Urbino University (1888) and the Florentine Carlo

²¹⁵⁴ *Atti della Società Italiana di scienze naturali*. Vicenza 1868 11: 340, 344, 380, 381, 384, 423-424.

²¹⁵⁵ *Archeografo Triestino*. 1890. 16: 338-339; Programma della civica scuola reale superiore in Trieste 1890; La Provincia dell'Istria. Capodistria 1. 7. 1890, 24/1: 84; Giovanni Radossi, Il carteggio P. Kandler - T. Luciani, Collana degli Atti, n. 39, 2014, p. 183; Angelo Scocchi, *Guglielmo Oberdan*, Trieste: Casa Editrice Adratica, 1926, p. 23.

Giuseppe Matteo Marangoni's (1840 Pavia–1925 Firenze) vacuum experiments. The essential part of Pizzarello's device were two strong pipes placed in communication by a thick rubber tube filled with mercury. The barrels were fixed to sliding supports along a large vertical rule, which was divided into centimeters and had a graduation clearly visible at a distance. The supports can be fixed on the side wooden rods by means of pressure screws. Pizzarello's apparatus allows to show the law of Boyle and Mariotte, to determine the coefficient of expansion and tension of the gases. It can also be used as the eudiometer, piezometer, pressure gauge, vacuum pump, or gas thermometer for Pizzarello's studies of the thermodynamic properties of saturated gases and vapors. In 1927 Pizzarello became a corresponding member of 2nd Class of Istituto marchigiano di scienze lettere arti of Ancona founded in 1925.

two weights. In addition, in 1872 (J. Streissler), 1878, 1879, 1881, 1884, 1885, and 1887 (E. Lindenthal) published papers on geometry, curves of the second order and other mathematical problems in the reports of the Real school in Trieste. Hofman wrote papers about ancient astronomy for the report of the gymnasium in Trieste in 1865, 1870, 1871, and 1873; the city thus developed into an important center of physics and mathematics.

Among the most important achievements on now Slovenian soil is Vlacovich's discussion on the duration of the electric spark, published in Koper in 1863. He continued the experiments he published in the previous year in *Nuovo Cimento* and in the Viennese academic magazine *Wien.Ber.* According to the example of Berlin's Professor of Mathematical Physics, Peter Theophil Riess, he proved²¹⁵⁶ that the spark is only apparently triggered in a moment; in fact, it contains a series of successive discharges, during which counter-currents are gradually eliminated. He measured the relationship between bound and free charge and produced high voltage with Riess generator in the Koper cabinet. Vlacovich's Klagenfurt colleague Robida also supported Riess's achievements from 1838, although the Viennese researchers were suspicious because of Riess's provocative assumptions that only the magnetism of a natural

magnet lasts, while all other substances are expected to be discharged over time.²¹⁵⁷

Vlacovich's research was inspired by the measurements of the light rays of the spark of Ruggiero Fabbri (Ruggero Fabri, * 1830 Ravenna; † aft. 1882 Ravenna) from the Roman university, published in the notoriously famous magazine *Il Nuovo Cimento* in 1855 ad 1858. Vlacovich used Riccardo Felici's supposed independence of the duration of the electrical spark from the circuit in which sparking occurs, published in the 15th volume of the same newspaper.²¹⁵⁸ Felici published his work simultaneously with Vlacovich and initially did not know the findings of his competitor Vlacovich. The sparking time is supposed to determine only the distance that the spark skips;²¹⁵⁹ according to Felici, the properties of the circuit should only affect the luminosity of the spark during discharges. Today we know that the luminosity of discharges depends on the tension that causes it, and therefore Vlacovich's doubts seem to be justified.

Vlacovich's critical attention was mostly focused on Carlo Matteucci (1811 Forlì–1868 Livorno)²¹⁶⁰ and Felici's achievements in Pisa. Matteucci studied physics and mathematics in Bologna until his promotion in 1828/29. During his specializations at the Paris Polytechnic School, he became acquainted with academician Arago. In 1831 he returned to his native Forlì and Bologna, full of liberal views, nothing that his respective authorities loved: he had to escape to Florence in 1834. They offered him a position in pharmacy, but he preferred to live among the merry Parisians, and after the publication of his paper in Parisian academical journal, Humboldt and Arago helped him to achieve a chair in Pisa (1840). In 1835, independently of Faraday, he laid down the laws of electrolysis, in 1841 he was rewarded by the Parisian Academy for physiological experiments, and three years later he also received the Copley medal in London. The spring of nations did not leave him in the short term: in 1847 he started politics, and after the unification of Italy, he unified the programs of various universities in the

²¹⁵⁷ Robida, 1857; Rosenberger, 1890, 775.

²¹⁵⁸ Vlacovich, 1863, 358; Fabbri, 1858; Felici, 1852 and 1862. Fabri's (Fabbri) daughter Cornelia Fabri (1869 Ravenna-1915 Florence) was the first woman to graduate in mathematics from the University of Pisa on 30 June 1891.

²¹⁵⁹ Vlacovich, 1863, 10.

²¹⁶⁰ Matteucci, 1841.

²¹⁵⁶ Vlacovich, 1862b, 531; 1862a, 30, 33, 35, 47, 51, 52, 72.

Italian Kingdom as Minister of Education (1862). Despite of new challenges, he studied the polarization of dielectrics in 1847, and between 1853 and 1854 he researched the distribution of electricity in insulators besides magnetic and diamagnetic phenomena, which mostly interested Vlacovich. In 1859, he explained the effect of the northern light on telegraphic conductors.

The source of electricity in the fish torpedo was illustrated by the first physical model of the nerve as the basis of the subsequent achievements of Emil Du Bois-Reymond, who began to research under the direct Matteucci's influence. Riccardo Felici (* 1819 Pisa; † 1902 S. Alessio in Lucca) matriculated in Parma to finish his studies in Parisian Polytechnic and in Pisa, where he became Matteucci's assistant in 1846; in the revolutionary year of 1848, as a lieutenant, he fought in the university battalion, and in 1862 he took over the chair of just-named Minister Matteucci. Felici was one of the founders, initially the sole owner and, in the years before his death, the editor of the magazine *Il Nuovo Cimento*, where he also published Vlacovich's achievements; Felici became one of the directors of the *Scuola Normale Superiore* and a member of the national academy dei Lincei, which has been known since Galileo's days. Basically, he devoted himself to the theory of electrical induction and the mathematical form of Faraday's induction law (1851-1859), which the self-taught Faraday initially preferred to express in words. Felici investigated in parallel with Franz Ernst Neumann and Vlacovich; Felici's findings turned Hermann Helmholtz into a more general theory of potential. Vlacovich, of course, went a long way beyond the scope of the then experiments, claiming that the spark at the discharge consists of a quick sequence of shocks. Unlike Felici, he claimed the first shock to be the strongest among all of them. Despite the small total time, the spacing between individual shocks should still be much longer than the time that an electrical disorder needs to travel through the circuit with which we are sparking. The speed of electromagnetic disturbances was measured for the first time by the Englishman Charles Wheatstone in 1834 and 1835,²¹⁶¹ while important measurements were also made by Lower Carniolan (Dolenjec) Ignac Klemenčič in 1884 in Graz. During the time of Vlacovich's research, The Scotsman James Clerk Maxwell published the first discussions on a similar matter of electromagnetic

²¹⁶¹ Vlacovich, 1862a, 51, 52, 58

waves and light. The resistance of the circuit does not have any influence on the length of the spark²¹⁶² in contrast to Wheatstone's findings. Vlacovich tried to obtain accurate data on the absolute surplus of electricity during sparking.²¹⁶³ Vlacovich used the ideas about polarization of the vibrating molecules of the Geneva professor of physics August Arthur de la Rive for a polite criticism of the mathematics of Matteucci's book from 1852²¹⁶⁴ in accordance with the atomistic beliefs of Ettingshausen's School of Vlacovich's student years. Vlacovich was not far from the London views of John Frederick Daniell (1790-1845 London) or the induction ideas of Faraday himself, who, together with Wheatstone, researched the sequence of sparking in fire²¹⁶⁵ and studied Georg Christoph Lichtenberg's figures.²¹⁶⁶

To compile with the Matteucci's research of discharges by the negative electrode, Vlacovich used a textbook of the Parisian Polytechnic professor Jamin.²¹⁶⁷ He thoughtfully studied the breakthrough of the electrical spark through the molecules of card²¹⁶⁸ used for a tarot game or he even preferred a coastal popular briscola cards; Matteucci's measurements also dealt with discharges in a vacuum.²¹⁶⁹ Vlacovich promised further experiments to complement the achievements of the "famous" Matteucci:²¹⁷⁰ he completed them in the following year in Koper reports with experiments on semiconductor cotton and conductive water.²¹⁷¹ According to Riess's measurements of frictional electricity published in 1853 and 1867, he proved that the duration of the spark is inversely proportional to the warming²¹⁷² and the distance, and proportional to the resistance.²¹⁷³ Vlacovich's course of discharge remains interesting nowadays, as we do not yet have the prevailing theory to describe the events of atmospheric discharges during lightnings and thunder.

²¹⁶² Vlacovich, 1862b, 531; 1863, 11.

²¹⁶³ Vlacovich, 1862a, 40-46.

²¹⁶⁴ Vlacovich, 1862a, 48, 52, 56, 58, 62, 73.

²¹⁶⁵ Vlacovich, 1862a, 49, 58, 59, 73.

²¹⁶⁶ Vlacovich, 1862a, 66.

²¹⁶⁷ Vlacovich, 1862a, 62-63.

²¹⁶⁸ Vlacovich, 1862a, 68, 72.

²¹⁶⁹ Vlacovich, 1862a, 69.

²¹⁷⁰ Vlacovich, 1862a, 73.

²¹⁷¹ Vlacovich, 1863, 7.

²¹⁷² Vlacovich, 1863, 8.

²¹⁷³ Vlacovich, 1863, 10-11.

On 16 September 1868 the Veronese chemist Teodoro Triulzi as the secretary on second meeting of third extraordinary session (Seconda Seduta di terza riunione straordinaria) of *Società Italiana di scienze naturali* in Vicenza reported that Nicolò Vlacovich communicated his discovery. Vlacovich observed that a glass stick, slightly rubbed with a foxtail, gives negative electricity, while it shows signs of positive electricity if the scrubbing is prolonged sufficiently. Vlacovich also observed that a glass stick, rubbed until it began to show signs of positive electricity, and then abandoned to a natural discharging, indicated ever smaller quantities of this electricity, then passed through a point where electricity was negligible, and next gave the signs of its negative electricity. Finally, Vlacovich, guided by some theoretical considerations, made another experience. In a Bunsen's zinc-carbon pile or in another pile, Vlacovich covered with a substance suitable for defending the zinc itself from the action of the acid the surface of zinc, which is not directed towards coal, copper, etc. Vlacovich obtained the same deflection of Gaugain's compass that he observed with all the surface covered. In the first case the consumption of zinc was about half smaller than in the second. Vlacovich announced his right to make further experiments confirming this fact, which he believed to be important for the practical applications of electricity.²¹⁷⁴

During his other experiment in Trieste Vlacovich added a negative electricity to a glass rod with scratching, and with stronger rubbing made it positive. With Bunsen's battery, he rejected a magnetic needle in Gaugain's compass obtained from Paris.²¹⁷⁵ He then proceeded to compile electric batteries for the then fashionable lamps,²¹⁷⁶ which he later published as an echo to the prize awarded by the Venetian scientific institute to Paduan professor of technical physics Andrea Naccari (1841 Padua-1924 Torino) in 1872/72. First, according to Naccari, he summarized the development of research until Galvani's discovery;²¹⁷⁷ Vlacovich particularly praised Georges Leclanché's cell and de la Rive's experiments with peroxides at the Parisian

exhibition in 1867.²¹⁷⁸ The French railway engineer Leclanché developed his cell in Brussels during his self-imposed exile from Second Empire just few years earlier in 1866. Vlacovich was interested in the role of ammonium chloride as an electrolyte between carbon and zinc electrodes in Leclanché's cell,²¹⁷⁹ to which various researchers attributed surprisingly equal voltages.²¹⁸⁰ Vlacovich himself used Leclanché cell for regulating the movement of clocks for nine months;²¹⁸¹ the battery with chromic acid initially gave high voltage, but it quickly weakened.²¹⁸²

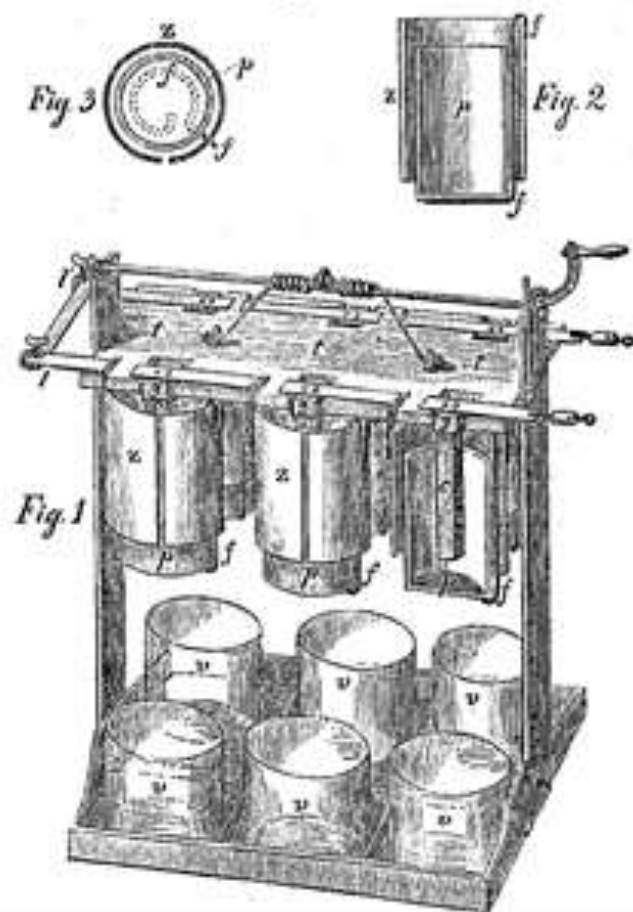

Figure 18-1: The sketch of a battery with zinc plates used in Vlacovich's experiments (Vlacovich, 1875, 144).

Naccari received his doctorate from mathematics in Padua in 1862. Then he lectured on experimental physics in Turin between 1878-1916; together with the relative of his fiancée, another Paduan professor of technical physics Manfredo

²¹⁷⁴ *Atti della Società Italiana di scienze naturali*. Vicenza 1868 11: 423-424.

²¹⁷⁵ Vlacovich, 1864; 1868, 424.

²¹⁷⁶ Vlacovich, 1870; 1880.

²¹⁷⁷ Vlacovich, 1875, 129.

²¹⁷⁸ Vlacovich, 1875, 130.

²¹⁷⁹ Vlacovich, 1875, 133-134; Sabaz, 2008, 201.

²¹⁸⁰ Vlacovich, 1875, 135.

²¹⁸¹ Vlacovich, 1875, 136.

²¹⁸² Vlacovich, 1875, 138.

Bellati (1848 Feltre in Belluno-1832 Feltre), they used chromic acid, but Vlacovich found out Naccari's discrepancy because he was not in conformity with Voltaic theories of electrolysis. Therefore, Vlacovich undertook independent experiments with Bunsen's²¹⁸³ battery and three batteries of the professor of analytical chemistry of Parisian École centrale des Arts et Manufactures Félix Leblanc (1813 Firenze-1886 Paris).²¹⁸⁴ Naccari improved Ohm and Poggendorff's procedure, supplemented by Du Bois Reymond; he measured the voltage of Daniell, Siemens, Grove, Smee and Bunsen's batteries with pure nitric acid²¹⁸⁵ to find suitable sources of voltage for the proper uses in telegraphy, just like Leclanché did for railways. Smee's battery was popular in Koper even later, as Carlo Sbuelz (Karol Žbuelz, * 1844 Solkan-Gorizia) bought it for the cabinet of physics in 1876 and in 1892 with twelve elements.²¹⁸⁶ The telegraphic batteries should avoid transmitting vapors: therefore, the French telegraphers used Leclanché's invention, processed towards later portable "dry cell",²¹⁸⁷ finally modified and patented by the physician Carl Gassner in Mainz in 1885/86. Naccari and after him Vlacovich were particularly interested in electric lamps powered with the batteries of the priest Nicholas Joseph Callan (1799 Darver between Drogheda and Dundalk north of Dublin-1864 Maynooth east of Dublin) and Bunsen;²¹⁸⁸ Vlacovich personally sketched his experimental devices with zinc and carbon electrodes soaked in sulfuric acid.²¹⁸⁹ As a diligent student of Ettingshausen who was already ill in that time, Vlacovich presented the hydrogen atom as a part of the acid molecule in the electrolyte.²¹⁹⁰ Although the littoral (Primorska) oil lamps had not yet been replaced by electric lights, Vlacovich has already studied the dynamos of the Parisian Belgian Gramme from 1869/70, which he observed at the Viennese International Exhibition in 1873 and published a report about the show.²¹⁹¹ Vlacovich was also interested in the use of electricity in

medicine and galvanoplasty;²¹⁹² the latter was presented by Prof. H. Mitteis of Ljubljana at a lecture in front of the Society of Carniolan Provincial Museum on March 5, 1856 under the title Use of galvanometry; light, thermal and electrical effects of electroplating and on 18. 3. 1856 under the title History of galvanoplasty.²¹⁹³

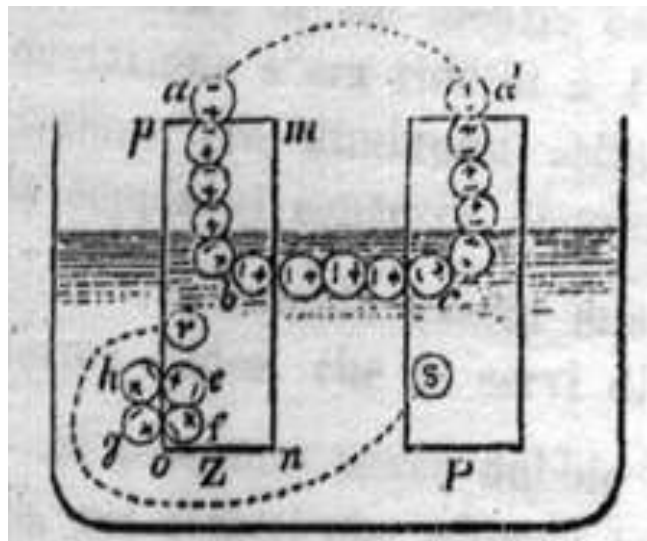

Figure 18-2: Vlacovich's electrolysis with zinc-carbon, platinum or other metal plates in strong sulfuric acid (Vlacovich, 1875, 145).

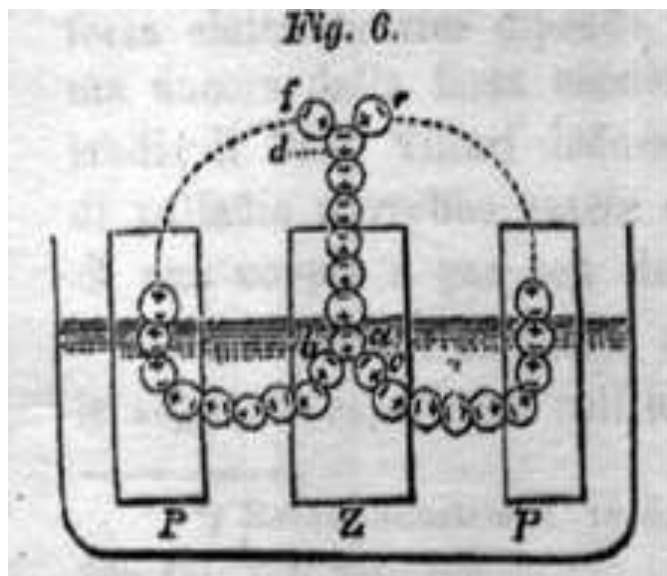

Figure 18-3: Vlacovich's electrolysis with zinc-carbon plates and nice drawings of zinc molecular moving (Vlacovich, 1875, 146).

²¹⁸³ Vlacovich, 1875, 139.

²¹⁸⁴ Vlacovich, 1875, 140.

²¹⁸⁵ Vlacovich, 1875, 141.

²¹⁸⁶ Programma Capodistria, (*Reports of Grammar school, Izvestja Gimnazije*) 1876, 82; 1892, 49.

²¹⁸⁷ Vlacovich, 1875, 141.

²¹⁸⁸ Vlacovich, 1875, 142-143.

²¹⁸⁹ Vlacovich, 1875, 145.

²¹⁹⁰ Vlacovich, 1875, 146.

²¹⁹¹ Vlacovich, 1875, 147.

²¹⁹² Vlacovich, 1875, 148; 1876.

²¹⁹³ Dežman, 1858, 91.

Vlacovich attributed the decisive importance to the affinities of gas and the electric force - therefore, according to Bologna University professor Emilie Villari, Vlacovich preferred to use palladium than Grove's platinum in the battery, as Vlacovich discovered an increased activity of hydrogen needed for production of palladium oxide on a positive electrode. In contact with palladium, hydrogen is more prone to oxidation than in contact with platinum: Vlacovich searched for the correct chemical formulas of palladium compounds with hydrogen and promised to continue his investigation of hydrogen compounds with potassium or sodium.²¹⁹⁴

18.2 Vacuum Pumps among Slovenes after the Spring of Nations of 1848

18.2.1 *Geissler, Crookes, X-ray and Braun's Cathode Ray Tubes for Slovenians*

The Slovenian aeronaut Kraškovič (Kaskovich) flew in the era when steam engines with vacuum techniques also began to develop in Slovenian towns. The steam engine was a kind of introduction to the triumph of vacuum technologies that followed Geissler's invention of the cathode-ray tube and Vlacovich's research of discharges already oriented towards the Italian milieu. In addition to Ljubljana, the cathode ray tubes were also purchased early by Vlacovich and the other Koper professors, among them a costly rubber balloon with a copper tap, usually designed for exploring gases and a Ruhmkorff inductor, discharged through the cathode ray tube of Heinrich Geissler. It was purchased Koper in 1870 for a price of 3 fl. In the years 1897 and 1907 they acquired the new (Braun's) cathode ray tube in an adapted collection. In 1905 they received a radiotelegraphic Marconian apparatus, and in 1907 and 1908 X-ray machine along with Crookes and Hittorf cathode ray tube for experiments with just discovered rays or particles.²¹⁹⁵ Under the auspice of Boltzmann's brother-in-law Šantel Gorizia high

school equipment was comparable to nearby Koper.

In 1876, the Ljubljana cathedral priest, canon, and speleologist Anton Urbas was interested in Geissler tubes, galvanic electric engraving, electric light and artificial fire.²¹⁹⁶ The only true Carniolan breakthrough was achieved by Anton Codelli, the baron of Ljubljana, who already used the term electron for a cathode ray,²¹⁹⁷ although he also repeatedly wrote about the cathode ray deflection in his typewritten application for US Patent application.²¹⁹⁸ He explicitly described a transmitter with a long Geissler tube placed on the same surface with a diffused reflector made of glass.²¹⁹⁹ The Ljubljana vacuum was therefore born at least on Kodeljevo, if we ignore the school experiments of Codelli's predecessors. It is not possible to prove convincingly that the first Slovenian vacuum researcher, Prince Janez Vajkard Auersperg, brought a vacuum pump to Ljubljana, although he significantly contributed to the first pumping experiments. As expected, Slovenes became acquainted with the first vacuum pumps more through technology than by any theoretical scientific concepts. During the advent of the French Revolution, the first books on steam engines started to appear among Slovenes; right then, professor Gabriel Gruber on Mura river tested the early steamer and together with his brother commented on the freezing of the steam at the valve of pump used for of the extractions of waters from mine in the Slovakian Banská Štiavnica. Early vacuum experiments did not have a real echo in Ljubljana, although among the city inhabitants was a vacuum research pioneer, the prince Janez Vajkard Auersperg. Even the first industrial-oriented vacuum pumps can be found in the schools of the Slovene national territory following the efforts of individual educators like Stefan's teacher Robida in Klagenfurt. Barely a Geissler's invention and the obvious advantages of cathode ray tube in electrical engineering have enabled the massive contact of Slovenes with the technology of vacuum pumps, which lasts even today when Slovenians are among the top experts for them.

²¹⁹⁶ Urbas, 1876, 27.

²¹⁹⁷ Codelli, AS, box 19, 16, illustration 10 (today those illustrations are almost lost as illustration 10 does not correspond to Abb. 10, which shows L. Weiller's mirror drum).

²¹⁹⁸ Codelli, AS, box19, p. 75 .

²¹⁹⁹ Codelli, AS, box19, p. 67–68.

²¹⁹⁴ Vlacovich, 1875, 149-151.

²¹⁹⁵ *Reports of Grammar school (Izvestja Gimnazije) Koper*, 1907, p. 61.

18.2.2 *The First Photographs of the Supersonic Missiles of the Son of the Landowner in Gorjanci Region for the Recording of Modern Plasma Turbulences in the Magnetron*

18.2.2.1 Introduction

Both metal sputtering and high-speed flash photography of ultrasonic missiles were closely

connected with Slovenes through Stefan's and Salcher's homeroom gymnasium professor Robida, and Mach's father the landowner in Veliki Slatnik between 1858 and 1879. The merger of both achievements with the modern ultra-speed recording of plasma turbulences by sputtering with the magnetron developed for radars during the Second World War, may once again witness an important Slovenian participation. It builds on the shoulders of the Ljubljana physical core, as it began to develop in the Jesuitical classrooms three centuries ago.

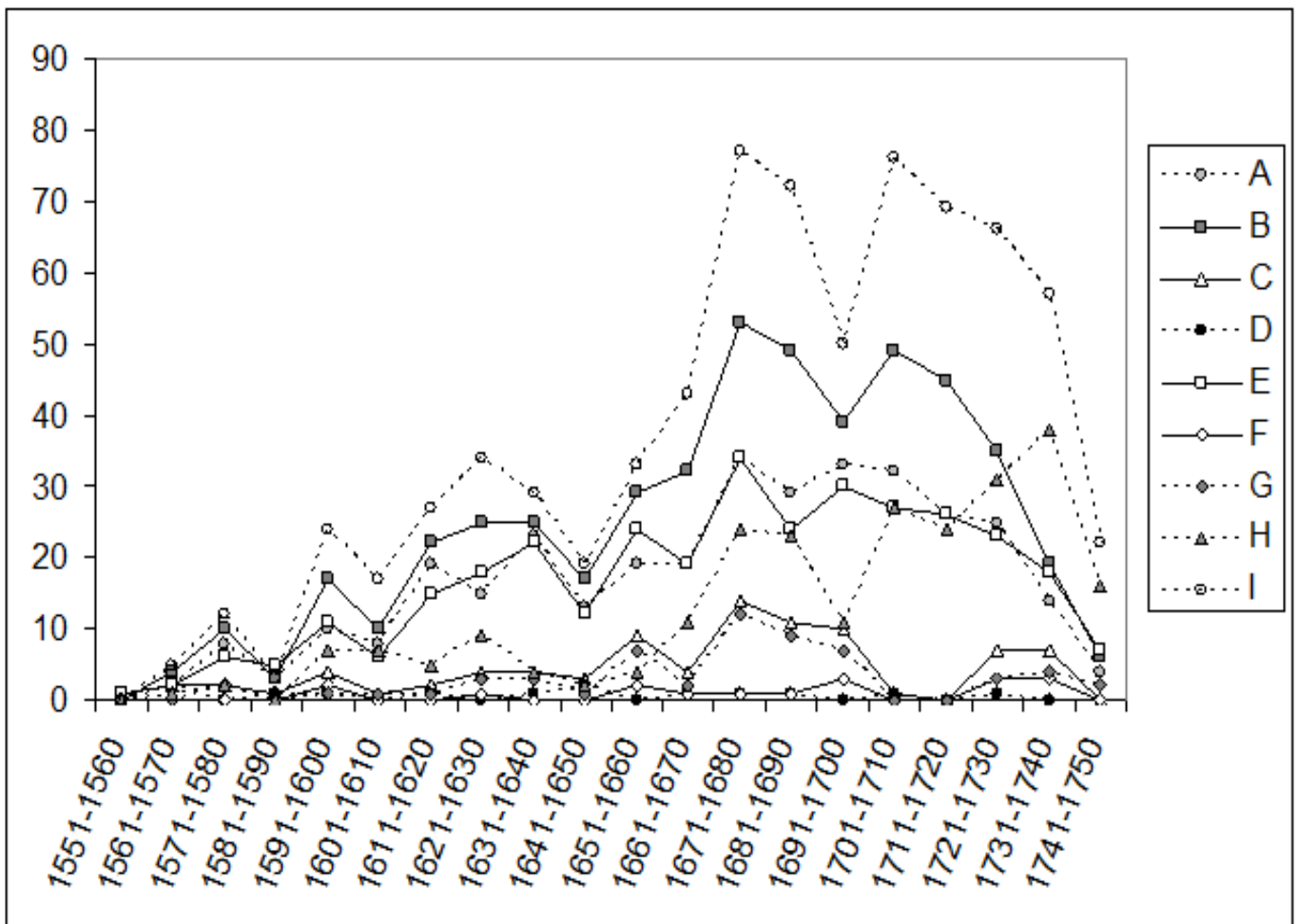

Figure 18-4: 1449 Jesuit of Ljubljana, including professors of mathematics and philosophy with physics and their writings, arranged according to the year of the birth of the authors. A: The first chairs of physics out of a total of 335 by decades, B: All chairs of physics in the years 1560-1750 out of a total of 488, acquired by 264 Ljubljana professors of philosophy with physics or mathematics out of a total of 1,449 Jesuits employed in Ljubljana, C: Number of publications in technical sciences (Mathematics, Physics, Astronomy) of the Jesuits of Ljubljana out of a total of 100, D: Astronomical books of a total of 10, E: All works of a total of 330, F: Mathematical papers out of a total of 20, G: Publications about physics among 70 of them all, H: All professors of mathematics and specializations from a total of 251 - distributed by decades of birth of educators, I: The professors of mathematics and physics and specialized experts in those fields by their decades of births out of a total of 739 Jesus

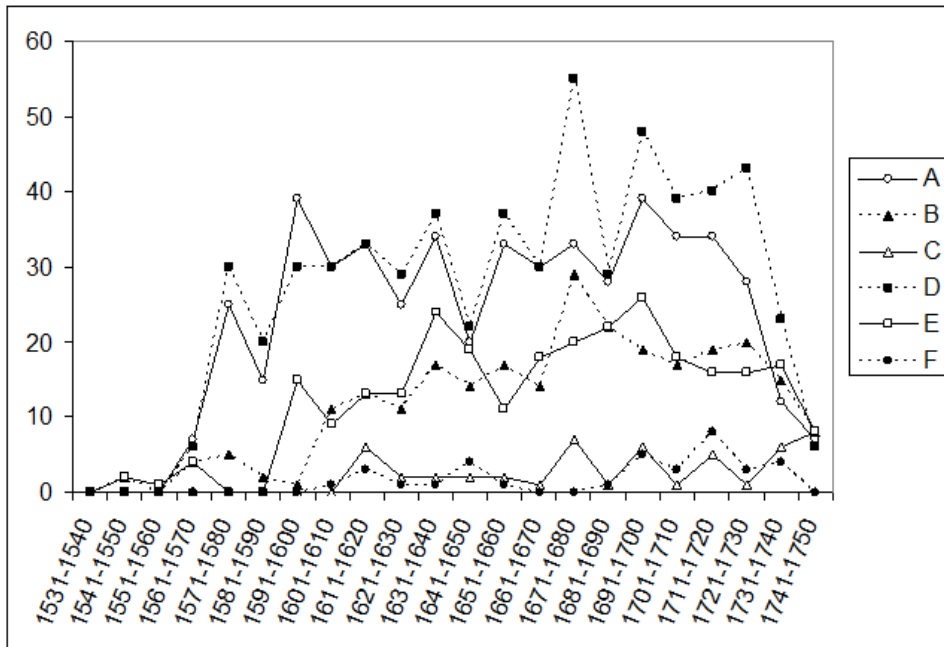

Figure 18-5: 1449 Jesuits, including the Ljubljana professors of mathematics and philosophy with physics as students of philosophy and theology according to their decades of birth. A: Starting a study of philosophy in Graz from a total of 506 students among 1,452 Jesuits, B: A Philosophical studies in Vienna out of a total of 259 future professors of mathematics and physics in Ljubljana, C: A study of philosophy in Trnava out of a total of 42 students among future Jesuits in Ljubljana, also professors Mathematics and Philosophy of Physics, D: A Study of Theology in Graz from a total of 587 students between 1453 Jesuits, E: The beginning of theology studies in Vienna out of a total of 1,449 future Jesuit Jesuits, including numerous professors of mathematics and physics within philosophy, F: Theology studies in Trnava out of a total of 35 future Jesuit of Ljubljana, among them numerous professors of mathematics and philosophy of physics

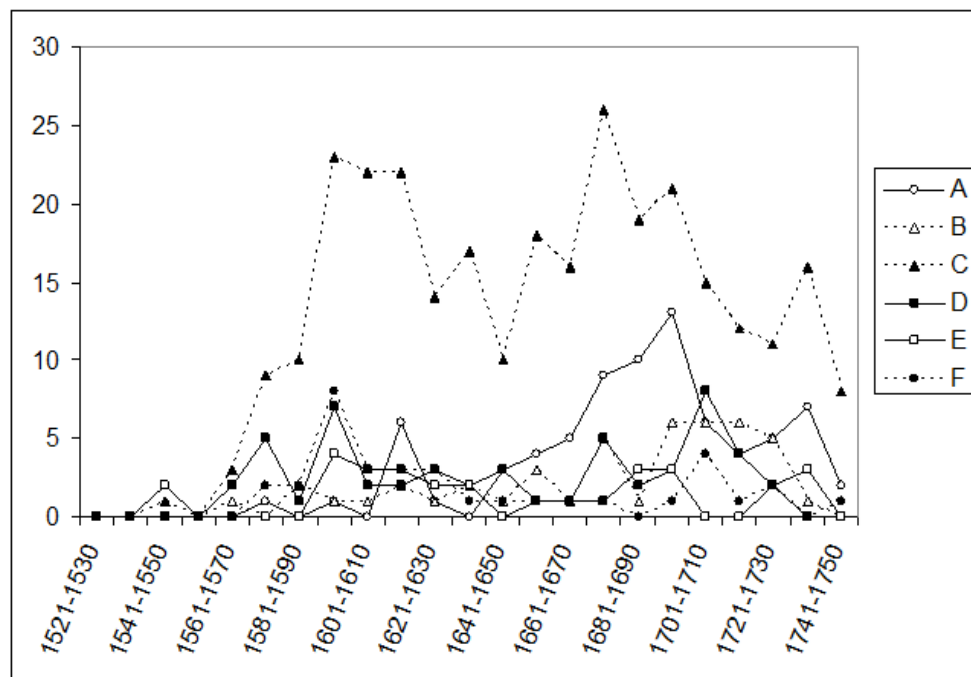

Figure 18-6: "The Slovenians and Croats" among the Ljubljana Jesuits. A: By decades of birth from a total of 77, B: Missionaries by their decades of birth out of a total of 45, C: 293 Carniolans among 1449 Jesuits distributed by their decades of birth, D: 53 Croatian Jesuits among 1452 Ljubljana Jesuits, distributed after their decades of birth, E: 30 Lower Styrian among 1449 Ljubljana Jesuits, distributed after their decades of birth, F: 37 Gorizia natives among 1,449 Jesuits of Ljubljana, distributed by their decades of birth

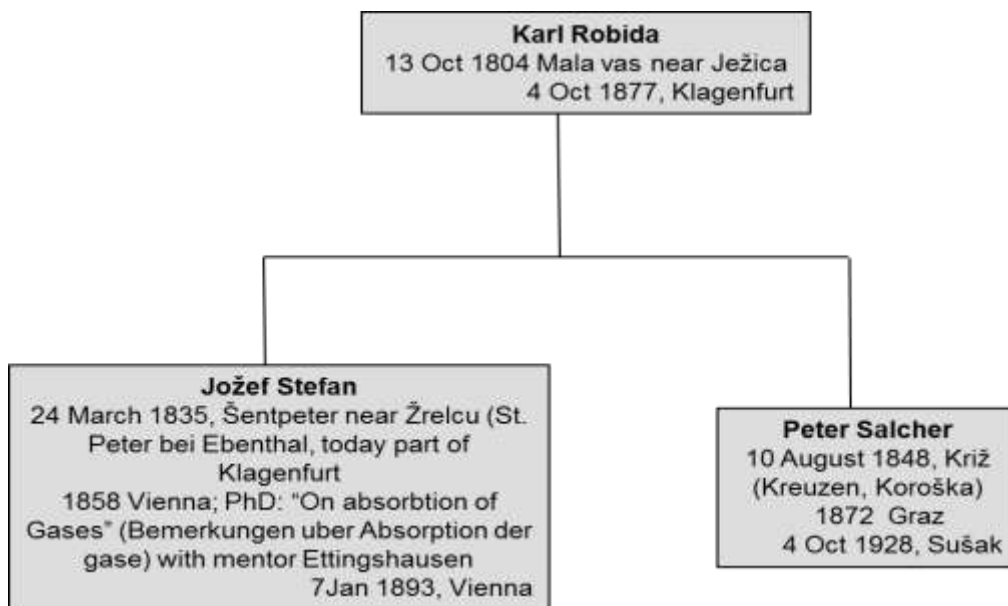

Figure 18-7: One of the pioneers of sputtering of thin metal layers Karel Robida with his pupils Stefan and Salcher. (Spremeniti: Dunaj v Vienna, Celovec n Klagenfurt, Gradec v Graz, doktoriral v received his PhD)

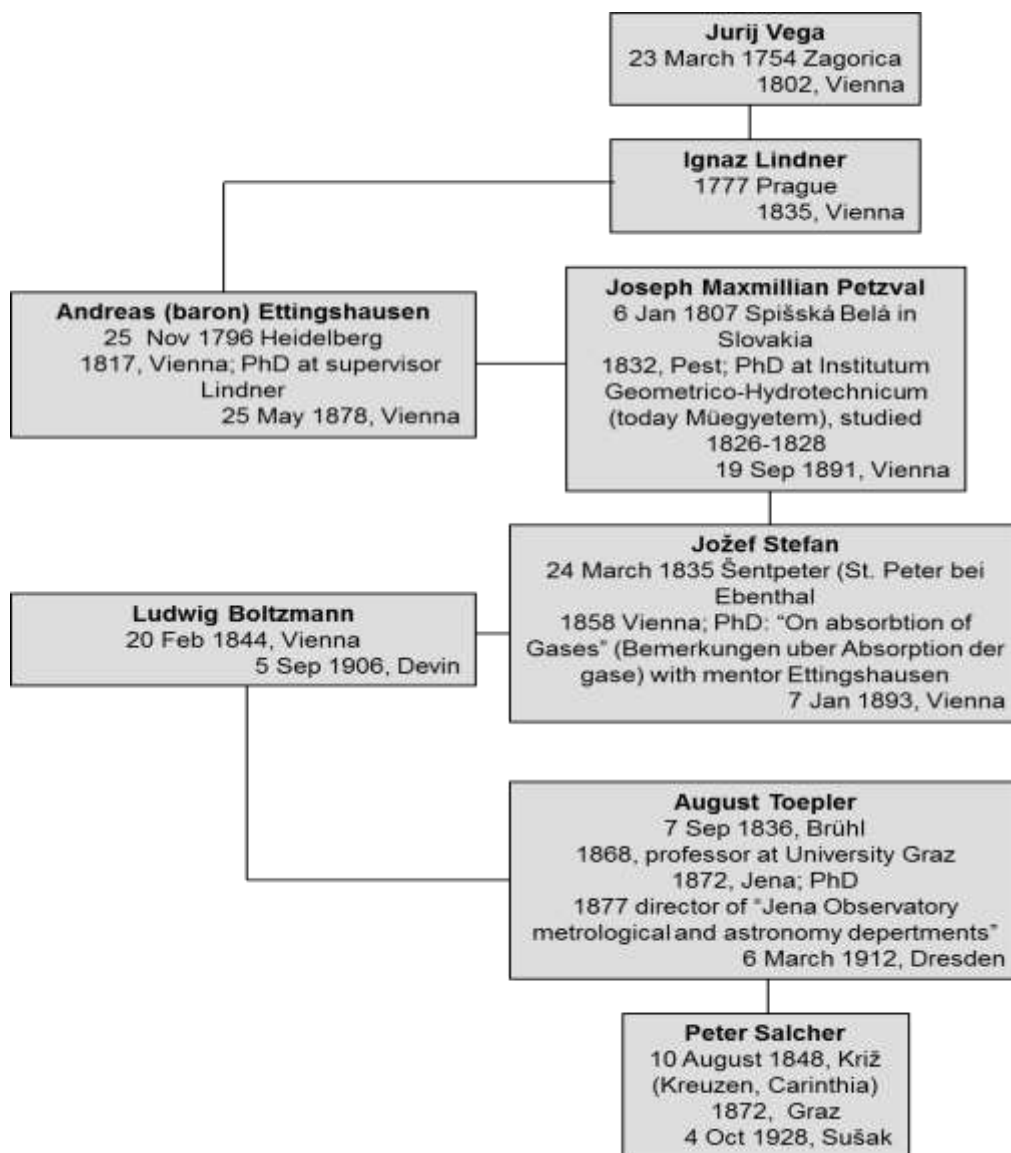

Figure 18-8: Jurij Vega and his academic descendants including Salcher

18.2.2.2 Machs among the Butterflies from Veliki Slatnik

130 years ago, in January 1886, a renowned Prague physicist, Ernst Mach, wrote to his ten years younger professor of physics from the department of the Maritime College of Rijeka, the Carinthia native Peter Salcher. Until then they did not know each other, but Ernst urgently needed Peter's help. What was the problem that marked so profoundly their and ours everyday life? Why did pacifist Mach need access to the Rijeka factory of two decades previously invented torpedoes that even Napoleon rejected at his time as unethical along with submarines of the American Robert Fulton

At the first International Electricity Exhibition in Paris in October 1881, Mach looked for new experimental challenges. He listened extensively to the lecturer Louis Henry Friderik Melsens (1814 Leuven-1886), a permanent adviser to the Belgian military School. Dumas' Parisian student Melsens spoke about the tearing of tissues and in widening the sphere of injury of gunshot wounds of people and horses, especially about the acute victims of the French, who injured their enemies with the fastest supersonic missiles of that time. As early as 1872, immediately after the Prussian-French war, Melsens assumed that the destruction of the wounded tissue was caused by the compressed air that the projectile pushes ahead. Of course, Melsens was based solely on observations of wounds of poor victims without any photographic review of events that had not yet been available to him at that time. Ernst was a different man, since he already learned all about the photographic procedures from his teacher, the officer's son, Andreas Baron Ettingshausen, who studied in his time at the Bombardier Viennese School with the disciple of prematurely killed Jurij baron Vega, the captain Ignac Lindner. Ettingshausen used the process of L. Daguerre (1787-1851) and first photographed through the microscope in 1840, while Ettingshausen's assistant was his son-in-law crystallographer Josef Grailich. Mach enthusiastically picked up the photography as the new experimental aid. So, he took a photographing as his enthusiastic work, especially during his holidays with his parents and three younger sisters in Veliki Slatnik under Gorjanci, 5 km south of Novo mesto. After their mother's death, Ernst Mach's youngest sister Wilhelmina, was somehow attached to the nice domestic servant, which Janez Trdina cleverly arranged in his story *Zakleti oreh*

(Cursed Nut). The otherwise liberal Ernst Mach proved to be a hard member of his privileged social class as he sent his own sister Wilhelmina into an Austrian monastery for good. During his Lower Carniolan (Dolenjska) vacation, Ernst often designed his experiments, which he then showed to the world. He was strongly advised by his father, the imaginative Slatnik landowner Johan Nepomuk Mach (1805-1879), who studied at Charles University in Prague in his time and taught his teenaged son Ernst at home. In 1840, Johann became the owner of the large estate of Untersiebenbrunn in Marchfelde in Lower Austria between Vienna and Bratislava, so that Ernst grew up in the countryside. At the time of Ernst's birth in Brno, Johann Mach was the educator of the children of Baron Breton and Josephine, born Lanhaus,²²⁰⁰ and later he tutored the children of Kunigunde and Franz Seraph Stadium Count Warthausen (1806-8. 6. 1856) the later interior and school minister in the years 1848-1849. E. Mach's grandfather was Joseph Mach. Ernst's mother, Josepha Lanhaus's father, Wenzl Lanhaus, designed the roads. Ernst himself studied for three years and graduated with his Matura in the Piarists' college developed from the former Moravian non-Jesuitical grammar school in Kremsier (Kroměříž). E. Mach's teacher of science was Franz Xavier Wessely (Veselý, 1819, Rajnocovice-1904, Kroměříž), who lectured in Kroměříž between 1854 and 1881 and described in detail the local plants²²⁰¹ while Mach's older Viennese classmate, Gregor Mendel of Vienna, established his genetic laws in the Augustinian monastery not far away in Brno.

Despite all their skills, the father and the son Mach under Gorjanci could not solve the experimental puzzles of Melsens' ballistics, since the photography of the wave head of the projectile in the air was by no means successful. Ernst carried out numerous experiments in Slatnik and Prague, but he did not see anything promising on his expensive photographs, which was already supplemented by the inventions of Janez Puhar in Ernst's teenage years in Bled. Ernst suspected that his missiles were too slow and did not reach the supersonic speed. He suspected that the high speed with the breakthrough of the sonic barrier is responsible for the terrible wounds of fast French missiles, and not just the compressed air from the

²²⁰⁰ Carus, 1911, 22.

²²⁰¹ Carus, 1911, 24.

Melsens' assumptions. Ernst and his father repeatedly overwhelmed the situation, since his father was well acquainted with his year and a half older Prague teacher between 1835 and 1847, Christian Doppler. In 1842 Doppler presented the famous Doppler effect to the Prague-based scientific society once lead by T. Gruber and Bernard Bolzano, of course known under its academic name barely later. Ernst, after his father's narrative, accepted the inventive Doppler for his idol, even though Doppler died too fast before Mach's studies in Vienna, where Doppler was replaced by Ettingshausen. Of course, Ernst did not disturb himself, and in his first independent work, according to Ettingshausen's advice in 1859/60, he proved the exactness of Doppler's theory of changed frequency of the sound and light of moving missiles, which was opposed by the Viennese university professor of mathematics, an expert in optics, somewhat special Hungarian Josef Petzval. In 1873 Ernst published a book on Doppler optical-acoustical experiments, which he honestly dedicated to his idol for many inspirations.



Figure 18-9: The last of the six photographs published by Mach and Salcher under the title *Photographische Fixierung der Projectile und der Luft* in the newsletter of the Viennese Academy in 1887.

To both father and son Mach it was soon apparent that their research of supersonic ballistics would led them nowhere without the participation of leading Hapsburg military circles, which only had access to sufficiently fast missiles, while their findings were often kept confidential. Mach needed connections with senior officers, and the choice of course naturally dropped to the nearest

among them. In 1853 75 km south of Mach's farm in Rijeka (Fiume) they started work in the later Torpedofabrik, and in 1854 they founded the Imperial Royal Military Maritime Academy. Rijeka was traditionally connected with Carniola and even formally its part in the times of Ernst's grandfather, but now Rijeka has progressed urgently as the main port of the Hungarian half of the monarchy, subordinated directly to Budapest. The prematurely died dr. Albrecht Wenzel von Tegetthoff (1841 Graz-July 22, 1871) was the youngest brother of the supreme commander of the Habsburg Navy vice-admiral victorious by Vis Wilhelm von Tegetthoff (1827 Maribor - 7. 4. 1871). Albrecht taught mathematics and hydrography at the Rijeka Military Maritime Academy. The son of retired major Franz Charles Gabriel (1790-1858), Albrecht, studied at the Theresian Academy and at the Viennese Faculty of Philosophy. Immediately after his doctorate he published a computing manual when he was twenty-four years old. Ernst's younger friend Giulio Peterin (Julijski, Julius, * 1846) graduated from the Grammar School in 1854/55 and, after completing his studies, lectured at the Rijeka Military Maritime Academy from 1861 to 1893 or even 1897. He published at the journals of Viennese Academy, just like Ernst Mach himself. Thus, the clever Mach used a common friend from Rijeka Peterin for an intermediate, so that he could send a letter addressed to the professor of physics at the military-naval academy Peter Salcher. Mach asked Salcher to set up experiments suitable for photographing supersonic missiles in the new Rijeka torpedo factory.

Peter's intervention was crucial for the very beginning of work if Ernst wanted to verify the presumption of ballistic impact wave head in front of the supersonic missile of Melsens who recently passed away. Ernst had an idea, and Peter added his owns with the opportunity to experiment within the military facilities included. Ernst and Peter did not personally know about each other much: Ernst stopped teaching at the University of Graz just before his decade younger Peter matriculated there in the year 1868/69. At the Viennese Electric Exhibition under the scientific and technical leadership of Jožef Stefan, Peter and Ernst indeed exhibited their inventions in the adjacent pavilions, but they did not even meet much in person at the time. Now it was time for great collaborations. Although he did not emphasize this in his first

letter on 25. 1. 1886, Ernst certainly knew that his experimental ideas could only be carried out in a fabric of torpedoes bought by Englishman Whitehead (1823-1905) in 1875 before his son-in-law renamed it to Torpedofabrik Whitehead & Comp. In 1878, representatives of governments of eighteen countries, including the pedantic Japanese, signed contracts with the factory, and in 1881 they had already exported torpedoes from Rijeka worldwide. In 1889, the original caliber of 356 mm was increased to 381 mm, 450 mm and 533 mm, thus exceeding the half-meter limit; and in 1892 a branch in Weymouth near Boston in the United States was established to avoid US import taxes. Ernst's father, from the nice castle under Gorjanci, keep himself well informed with the progress of the factory in nearby Rijeka, so he advised his son to connect with the Rijeka military experts. Unfortunately, Johann, died as a widower in Veliki Slatnik at the end of 1879, and thus did not see his son's supersonic ballistic successes. In Veliki Slatnik, among other things, he cultivated giant Japanese butterflies *Antheraea jamamao*, which are still flying around Slovenia and nearby, but for now still deep under the supersonic speed.

18.2.2.3 Robida's Student Salcher at the Torpedo Factory in Rijeka

Peter Salcher may have disagreed with some of Ernst's positivistic or even atheistic ideas that lifted a lot of dust in those days and even led Lenin to write a book against Mach and his Russian advocates. The more so, then, Peter respected Ernst's reputation as an older physicist, experienced in ingenious experiments. So, Peter did not have to be asked twice. He linked with the older co-owner of the torpedo factory John Whitehead (1854, Trieste - 1902, Rijeka). Together with Ernst, Peter published the findings of photographed supersonic ballistic experiments at the Viennese Academic journal from 1887 to 1890. In the final paper they highlighted the advantages of illumination of the photographed wave-head with Geissler's Cathode ray tube, whose "light had a very good photographic effect".²²⁰² They were assisted by the excellent photographers and chemists. Whiteheads were very interested in the results, as thermodynamic phenomena accompanying the high pressure leakage of the air explained numerous problems of torpedo

propagation, ranging from freezing due to Joule-Thomson expansion all the way to turbulences.

In Prague, Ernst used a pistol whose missiles did not break the sonic barrier and, therefore, the expected supersonic photographs, of course, were not successful. Salcher preferred to use 8 mm to 11 mm gun calibres to shoot off supersonic bullets with their speeds up to 530 m / s. The missiles were illuminated by the electric spark of the Leyden jar, while other local photographers helped in the shooting. They were firing their bullets at the military-naval academy, but not necessarily in the main building where shooting combat ammunitions was certainly not common. On 24 April 1886, Salcher sent Mach his first six successful photographs, barely three months after Mach's initial proposal. One of the first team designed for physical research succeeded, closely related to military needs at that time. Mach visited Salcher in Rijeka and attended an experimental launch of a torpedo during the Easter holidays between 22 March and 18 April 1887. In the autumn of 1887, Salcher continued the experiments in nearby Pula.

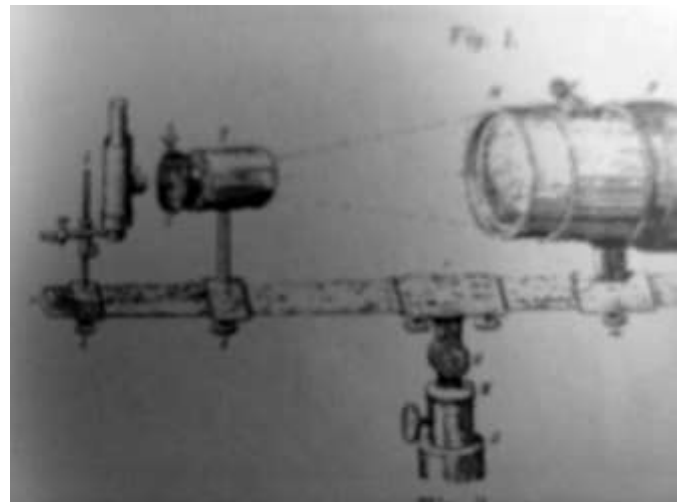

Figure 18-10: Töpler optical bench "Schieleren" from 1864, which inspired the successes of his pupil Salcher and Mach

Salcher shot a 90 mm bullet at a speed of 448 m / s in Pula, while Ernst Mach and his elder son, the Viennese medical student Ludwig, took photographs at the Krupp plant in Meppen by Hanover with 40 mm missiles at 670 m / s. Of course, the Mach unit was established only later, but it would do no harm if it was named after the equally deserving Salcher.

²²⁰² Mach, Salcher, 1890, 1306.

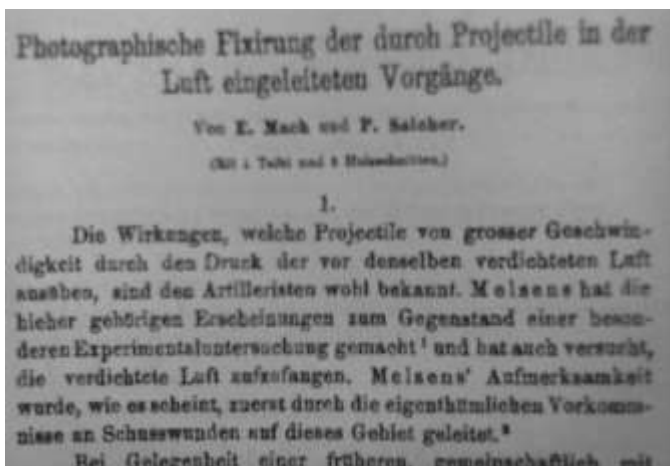

Figure 18-11: The cover page of Mach's and Salcher's pioneering article of supersonic photographs, which Mach communicated in the Viennese Academicians for publication in Wien. *Berichte* in 1887 in Volume 95/2 on page 764

Mach found that Melsens's ideas were not perfect, because the compressed air, pushed by the missile did not cause the unbearable wounds, nor did the air in front of the missile imagined by Aristotle in his time; the speed and shape of the bullet were the main factors. Also, Mach was finally able to explain why a bullet shot was heard twice on the battlefield; the first of the sounds originated from the breakthrough of the sonic barrier, which has since started to play its important decisive role in the physics of rapid movements. Mach became famous, even trendy; his and Salcher's photographs of supersonic missiles were also published by popular newspapers. Of course, Mach's old opponent Jožef Stefan was even more powerful, and he easily set Boltzmann and his other supporters of kinetic theory to fill all the important professorial positions in the Habsburg Monarchy, just as the advocates of Bošković's point centers of forces as the unique ancestors of the Stefan's atomists had done in the previous century. Mach's doubts about the existence of atoms were soon limited to his rare political supporters, which did not affect his successful experiments in couple with Salcher. In the early 1888's, Salcher reversed the idea of experiment and left the projectile steady while he directed on the projectile his jet of compressed air at 250 atmospheres at the Rijeka factory, where they produced the first torpedoes in 1866 and two years later in 1868 installed the torpedo ship named the *Gemse*, the first of its kind in the world. On April 4, 1888, at the Viennese Academy, Mach reported on the successful photographs obtained by the reversed Salcher's

experiment.²²⁰³ The experiments and correspondence between Peter and Ernst lasted until 1892, and a new chapter in ballistic science was written with them on the route between Prague, Veliki Slatnik, Rijeka and Vienna. The paths of both collaborators then split up: Salcher was already a naval officer of 8th rank in 1902, highly respected on the court. In 1894 immediately after his exceptionally successful promotion in Göttingen, Mach's younger son afforded one of the very modern suicides²²⁰⁴ that effected even the most prominent heir Rudolf Habsburg in 1889; four years after his son's tragedy, the saddened father Ernst was hit by the stroke, which disabled his right arm. Therefore, he had to abandon his Viennese philosophically oriented chair, which pleased Mach so much and caused his great disputes with Leninists and Mach's successor Ludwig Boltzmann, along with his half-Slovenian wife Jetti. Until his very end, Mach's work helped the Slovenes, among others, a professor of philosophy, mathematics, classical and living languages from Novo Mesto in the period between 1897 and 1921 Mihael Markič (M. Posavski, 1864 Kranj - 1839 Ljubljana). Mihael's adaptation of Boolean algebra, published in 1899, 1900, and 1914 in German reports of the Novo Mesto (New City) grammar school, was recommended by Ernst's oldest unmarried sister Marie (* 1844; † 1929), a rather successful writer of novels about Veliki Slatnik after her educational work with the Montenegrin royal family. In 1912 and in a revised edition in the following year she published memories of her mother with Ernst's foreword.²²⁰⁵ Despite of Mach's support, the Ljubljana professor France Veber (1890 Gornja Radgona-1975 Ljubljana) strongly criticized Markič and the mathematical logic in general in 1920.

Ernst's supersonic dream of Gorjanci was realized. The sound barrier (sonic wall) was intentionally broken for the first time. Half a century after Mach's death, the first supersonic aircraft Concorde flew with passengers on March 2, 1969, but after 26/11/2003 all twenty Concord aircraft were "retired". Similarly, it happened to Soviet Tupolev TU-1544 supersonic aircrafts, which were slightly faster by speeding up to 2.35 Mach, but they flied only from 1975 to 1978. Mach would certainly be sorry.

²²⁰³ Medica, 2011, 316–317.

²²⁰⁴ Carus, 1911, 31.

²²⁰⁵ Mach, 1912, 1913.

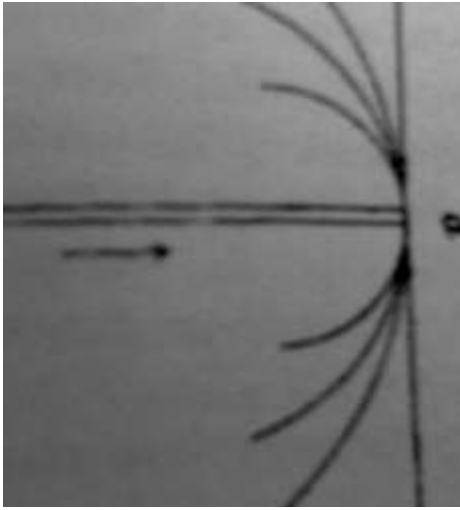

Figure 18-12: Huygens's two-hundred-year-old waves from Mach's and Salcher's pioneering article of supersonic photographs, which was published by newsletter of the Viennese Academy of Sciences Wien.Berichte in 1887 in Volume 95/2 on page 769

18.2.2.4 Ultraquick Photos to Improve the Thin Layer Sputtering

Mach ultraquick photography soon came to life out of strict ballistic use. Today, its of special importance for the study of plasma and its turbulences, which have a significant effect on the application of nanometric sputtered thin films. According to Grove's and Robida's sputtering of metals, Arthur Williams Wright announced the successful sputtering of many layers of platinum, gold, aluminium, zinc, iron and many other metals in the American Journal of Science in 1877. He also described their stability in the atmosphere as a condition for usability. Robida repeated Grove's sputtering experiment only five years after Grove in 1857. A decade later Robida became a homeroom (classmaster), professor of mathematics and physics of Peter Salcher. Robida's chief associate Simon Šubic was Salcher's professor of complete field of theoretical physics in the first year of Salcher's Graz studies, as Šubic lectured on physics in Graz from 19th March 1865 until 11 March 1867. In Graz, Ernst Mach taught mathematics in 1864. Šubic published a lot about photography for scientific purposes, including his popular articles in the Slovene language, while Robida already showed Salcher in Klagenfurt his decades old photograph taken with a microscope, probably obtained by Ettingshausen's newly invented method designed in 1840. Naturally,

Salcher comprehensively complemented Robida's knowledge with his Graz-based study of experimental physics during the construction of the largest physical institute in the Habsburg Monarchy of his professor August Toepler of Graz. Toepler's so-called schlieren photographic method, based on differences in air density, has become the foundation of Salcher's photos of supersonic missiles in Rijeka following Mach's instructions. Toepler did not participate in Rijeka experiments. Toepler was the bestman at Boltzmann's wedding with half Slovene maid Jeti. Jeti used to be the first Habsburgian female student of physics, while she ingeniously complained to her future fiancée Boltzmann about the supposed Toepler's antipathy. The physicist Toepler may have been somewhat reluctant about new experimenting in Rijeka after he was just upgrading his physical Institute in Graz in 1874. In the middle of his success he felt from the upper floor to the ground floor and severely damaged his body at Christmas in 1875.²²⁰⁶

Mach and Salcher did not use ultrasonic photography to record sputtering, but they made a great contribution to both fields. Initially after the invention of cathode ray tubes, metal sputtering seemed more like an unpleasant cathode ray tube failure, but not as an industry-friendly contribution to science of materials. Mach's admirer Einstein closely approached the development of magnetron, which is today one of the most promising devices for plasma sputtering of thin films, and at the same time a promising area for exploring plasma turbulences with ultra-fast bombardment. Einstein was Zurich university associate professor between 1909 and 1911. His heir to his position of university associate professor at Zurich University, his one-year younger fellow Heinrich Greinacher (31. 5. 1880-1974), developed a cavity magnetron as a new opportunity to measure or calculate the mass of electrons in Zurich in 1912, immediately after his arrival at a Zurich university. Einstein was then between 1912 and 1914 his neighbor as a professor at the Zurich ETH. In 1914, Einstein did not want to take over double professorships at Zurich University and ETH as Greinacher's co-worker, after both got doctorates or habilitated at the University of Zurich in 1905 and 1907 respectively. Einstein's neighbor in Zurich was also his onetime classmate, the researcher of specific heat Friedrich Adler, while Lenin wrote a devastating critique of Mach and Adler in nearby

²²⁰⁶ Jungnickel & McCormach, 1986, 67; Stiller, 1989, 53.

Zurich libraries.²²⁰⁷ The poor Lenin's victims certainly did not know exactly what's going on until Adler shot a hungry Hapsburg Prime Minister in a prestigious hotel restaurant seven years later on the afternoon of October 21, 1916. A year later Lenin got his fatal Russian power.

The promising beginnings of the magnetron were then taken over by the scholars on the other side of the Atlantic who were more favorable for moneymaking. The American Albert Hull (1880-1966) made his magnetron for General Electrics, Schenectady, New York, to circumvent the Western Electrics patent of triode. Hull controlled the magnetic field flow instead of the grid. Initially Hull did not intend to apply the highest frequencies of electromagnetic waves to his magnetron which was left to Prague University student Czech Avgust Žáček (1886-1961) and the Jena PhD student Erich Habann (1892-1968). They used the frequencies up to the gigahertz in 1924. The invention flourished during the development of radar in the Second World War, especially for the sake of the war for England, where John Randall (1905-1984) and Harry Boot (1917-1983), assisted by James Sayers (1912-1983) from the University of Birmingham developed the cavity magnetron in 1940. Secretly hidden from the Germans, the high security study was directed by the descendant of steam engine inventor James Watt, Robert Alexander Watson-Watt (1892-1873). He was a funny leader. When he was later as a famous man stopped by Canadian police officers for speeding, he exclaimed outrageously: "If I knew what you would do with my radar, I would never invent it!" It did not help and he was forced to pay a fee.

The industrial use of millions of cavity magnetrons then went on for many years in favor of microwave ovens until their fast-food households were criticized. A promising technique, however, found urgent new applications when competitors superseded it even in radars. While the cavity magnetron has an internal pressure of less than 0.01 Pa, the plasma sputtering magnetron has a working pressure of the order of 1 Pa. In the plasma magnetron, plasma is of key importance, since positive ions from plasma accelerate towards the negative cathode and thus disperse it. The similarity between the devices is in their crossing of the electric and magnetic fields in the greater part of the space, which causes the electrons to

move along specific trajectories; they rotate around magneticlines of forces and move simultaneously in a direction perpendicular to the electric and magnetic fields. Such an electron motion is used in cavity magnetrons to produce microwaves, while in plasma sputtering magnetron it is needed for the most frequent electron-gas collisions, that is, for the generation of as thick as possible plasma. The promising application of nanometric thin films in the magnetron for sputtering was first used in the 1970s in the simultaneous inventions of many planar magnetron researchers, where secondary electrons in the sputtering process and increasing the energy of the electrons on the surface and beside it, provide the energy necessary to maintain the discharge in the magnetron, which is alternately used as a cathode and anode at medium frequencies, high energies, but not at high densities of energy on wide surfaces.



Figure 18-13: Magnetron plasma shot with a fast camera (exposure time 10 ns, author of the image: dr Matjaž Panjan)

Unbalanced magnetron as the first step to the use of plasma for the growth of thin films with magnetron was first used by Brian Window and Nicholas Savvides (Nick Savides) at the Commonwealth Scientific and Industrial Research Organisation (CSIRO) at Sidney in 1986. The self-ignition with ions of the target itself was observed for the first time in 1977. The East German André Anders of Berkeley and others independently noticed the location of ionization in zones and self-organization in turbulences in 2012. Ionized parts

²²⁰⁷ Adler, Mach, 2001, 45.

contribute to the transfer of charge along the magnetic field forces with turbulent flow.²²⁰⁸ The naked eye sees the ionization process, distributed homogeneously. With the help of Mach-Salcher's device descendants called high speed CCD (ICCD) cameras, we distinguish several bright areas moving along the pattern. Such ionizing areas are called "spokes" in analogy with similar phenomena in plasma. They are maintained by electrons in complex electric and magnetic fields. Fast photography, of course, much faster than Mach-Salcher's, is a fundamental tool for determining the nature of these turbulences resembling older Mach-Salcher's turbulence of the impact wave of a projectile. High-energy pulse magnetron sputtering (HiPIMS) as a highly ionized technology already has good references from thin-layer manufacturers since it is compatible with existing PVD devices and offers very hard coatings and optical thin films. HiPIMS successfully supersedes the technologically identical High Power Pulsed Magnetron Sputtering (HPPMS) by increasing the ionization of the diffused target atoms with hundreds of times greater power densities compared to conventional methods.²²⁰⁹ Anders' collaborator the Carniolan Matjaž Panjan (* 1980) belongs to the most promising researcher of magnetron plasmas.

18.2.2.5 Conclusion

The picture captures the present moment for future generations. Fast or ultrafast photography capture even what a relatively cumbersome human eye cannot ever perceive. Therefore, it makes visible the things which are completely invisible to human eyes, like a microscope, a telescope, or the detectors of ultraviolet and infrared lights did in their times. The invisible might be too small, too quick or in wrong wavelength, but the tool could convert it for us. During Mach and Salcher's time, the flashing photography revealed the turbulence with supersonic bullet-proof missiles, which both Mach, father and son, discussed under Gorjanci. Tomorrow, for sure, will reveal turbulent plasma currents for more efficient sputtering with magnetrons.

18.3 Hočevar's Vacuum Techniques

18.3.1 Introduction

Ettingshausen and Robida's students Mach and Salcher developed the artistic ultrafast photography into scientific tool. The plasma figured as joint product of several field of research including Crooke's cathode ray tube fourth aggregation state and compressed ultrafast photography (CUP). As always, the careful mixing of different fields of scientific (and artistic) research brings unexpectedly useful results as vacuum technology has already intertwined with the testing of electrical devices at Guericke's beginnings; so, Otto Guericke indeed invented the basic device for both areas. The most important London manufacturers of vacuum pumps, Hauksbee and Ramsden, had upgraded Guericke's electrostatic friction to a modern device with plates;²²¹⁰ in the Leiden Musschenbroek vacuum pump factory or in a university laboratory across the street, Musschenbroek Leyden jar was developed as the first electric capacitor. The intertwining of vacuum and electrical research continued in the 19th century with the experiments of the Ljubljana professors Hummel and Bela Krajina native Hočevar. The research of vacuum and electromagnetism finally joined in Geisler's cathode ray vacuum tubes into a uniform field of research that is still flowering.

18.3.2 Hočevar in Ljubljana

Hočevar was the son of a district commissioner and a court adjunct in Metlika; according to his surname, he may have belonged to a Kočevje based family. With him, centuries after Klemen Kukec, Metlika produced another great mathematician and physicist. Between 1864 and 1871 he attended a gymnasium in Ljubljana in the class of a with popular mathematician Nejedli;²²¹¹ of course, he could afford a much closer Novo Mesto Franciscan Gymnasium with first-class physicist Bernard Vovk, who raised Ignac Klemenčič, but Hočevar's father had enough money to give his son the best instruction.

²²⁰⁸ Panjan, 2014.

²²⁰⁹ P. Panjan, Čekada, M. Panjan, Paskvale, Kek Merl, 2009, 31

²²¹⁰ Ganot, 1886, 692.

²²¹¹ Razpet, 2009, 136.

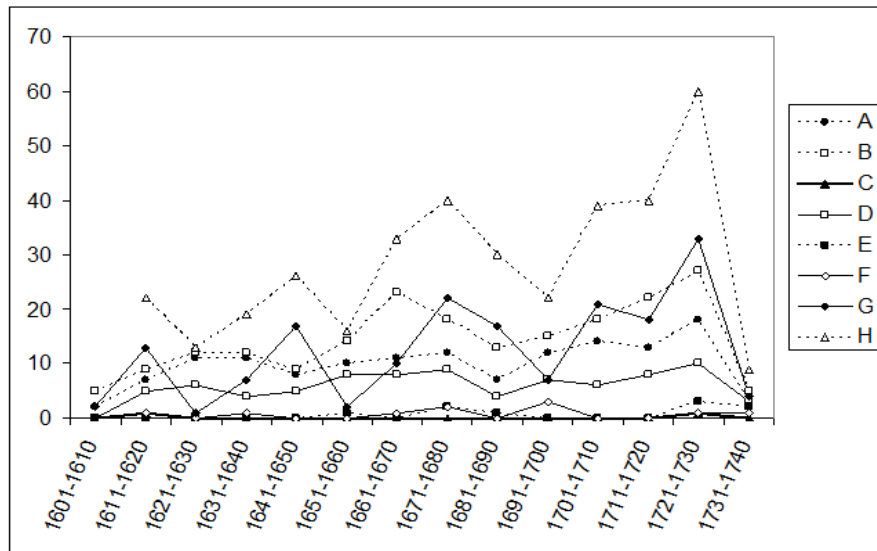

Figure 18-14: Professors of technical sciences and preserved papers of 155 Celovec (Klagenfurt) Jesuitical professors of mathematics and philosophy including physics with respect to their decades of birth. A: First chairs of professors of physics among Klagenfurt Professors of Mathematics and Philosophy out of a total of 140 plotted by decades, B: All professors of physics' chairs in the years 1560-1750 out of total of 204, lectured by 157 Professors of Philosophy with Physics or Mathematics of Klagenfurt, C: Publications about astronomy of a total of 2, D: All publication out of total of 84, E: Mathematical works of a total of 10, F: Physics writings out of total of 12, G: All professors of mathematics and specialized experts in mathematics out of total of 174 - distributed by decades of birth of professors, H: 378 Klagenfurt Jesuitical professors and specializers of physics and mathematics by decades of their births

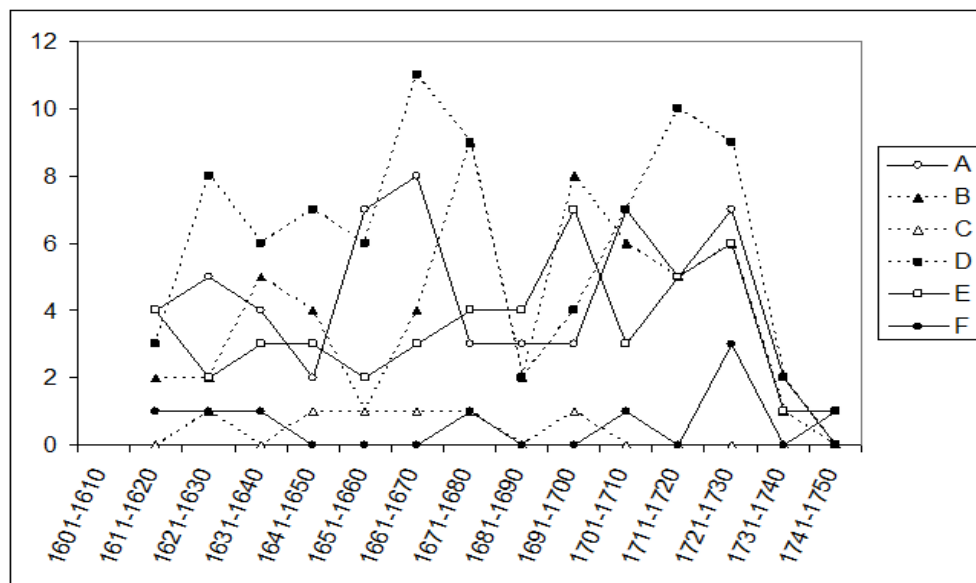

Figure 18-15: 155 Celovec (Klagenfurt) professors of mathematics and philosophy-physics as students of philosophy and theology according to decades of their births. A: Starting a study of philosophy in Graz out of total of 61 students among 157 professors, B: Starting a study of philosophy in Vienna out of total of 56 future Celovec (Klagenfurt) professors of mathematics and physics within philosophy; C: A study of philosophy in Trnava out of a total of 6 students among future Celovec (Klagenfurt) professors in mathematics or philosophy with physics, D: A study of theology in Graz out of total of 85 students among 157 later professors of mathematics and philosophy in Klagenfurt, E: Beginning of the study of theology in Vienna out of a total of 49 future Celovec (Klagenfurt) professors of mathematics and physics philosophy, F: Beginning of the study of theology in Trnava of 8 future Celovec professors of mathematics and philosophy with physics

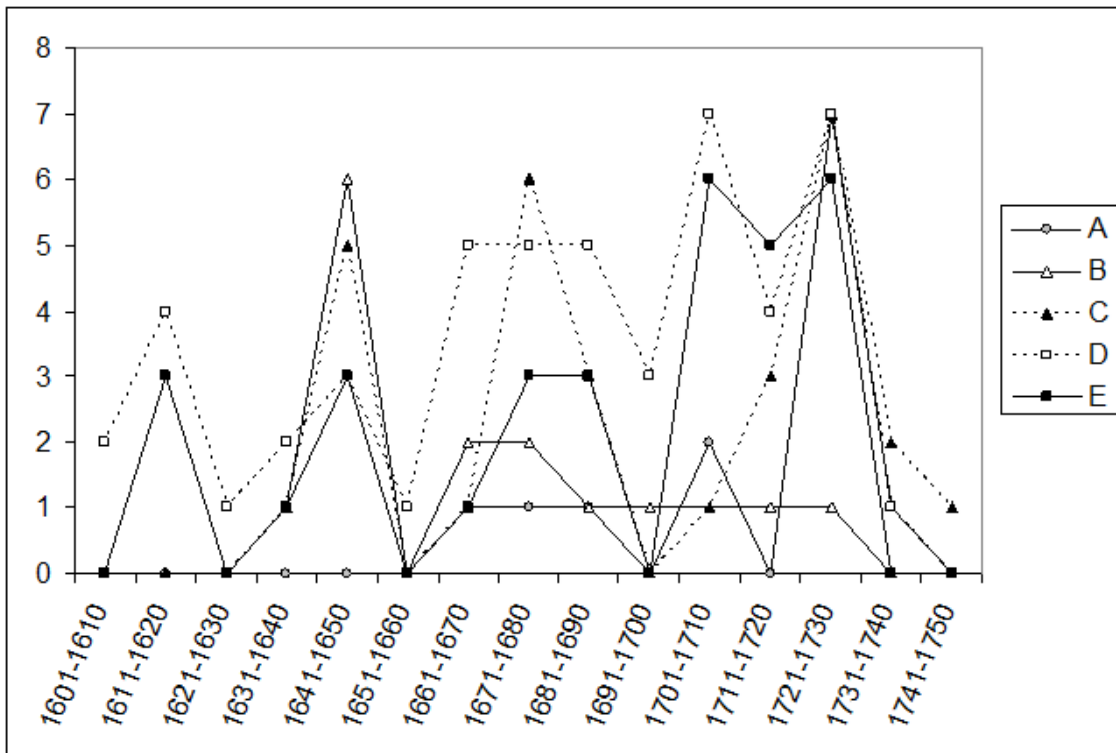

Figure 18-16: Celovec professors of mathematics and philosophy of physics in their five most common mathematical departments elsewhere. A: Ljubljana mathematics, B: Linz faculty of mathematics, C: Graz mathematics, D: Celovec (Klagenfurt) mathematics, E: Viennese mathematics.

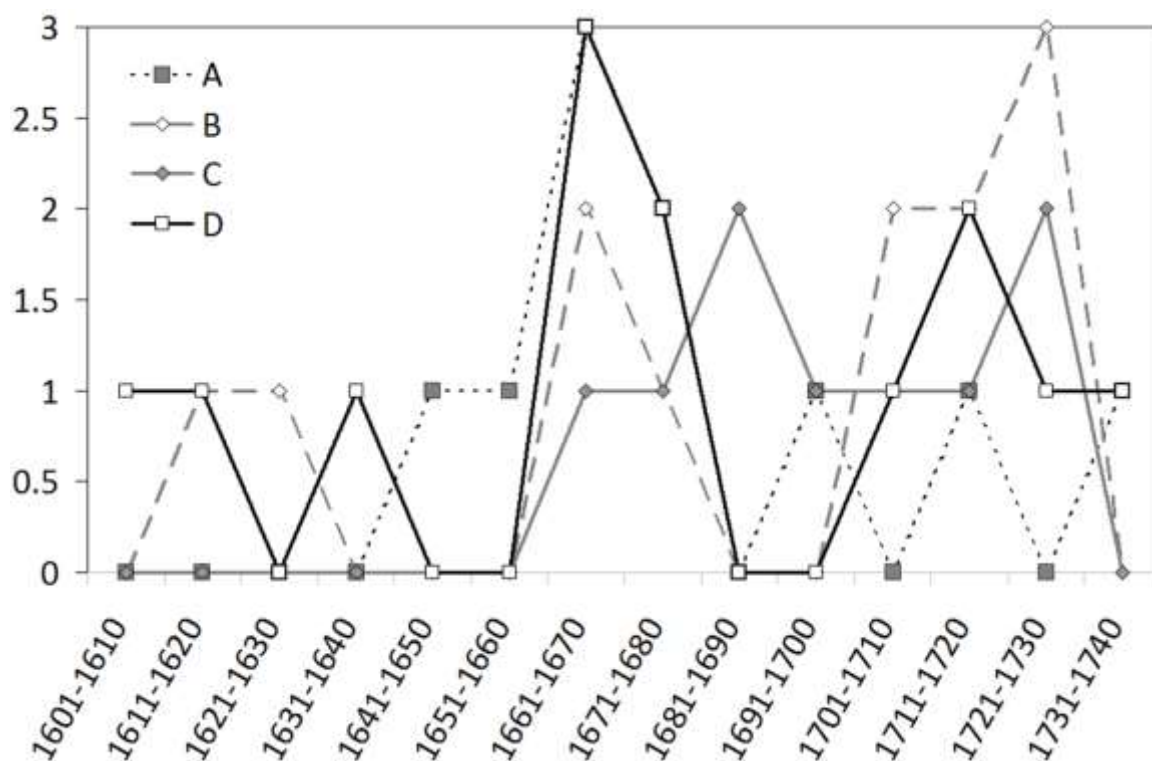

Figure 18-17: (Klagenfurt) professors of mathematics and physics in physics at their four most common philosophical departments elsewhere. A: Graz Chairs of Philosophy with Physics, B: Gorizia Departments of Philosophy with Physics, C: Ljubljana Chairs of Philosophy with Physics, D: The Passau Chairs of Philosophy with Physics

Josip Nejedli of Prague was not only a mathematician, but also one of the most important philosophers in Ljubljana. He came to Ljubljana as forty-one years old accredited researcher and pedagogue. He has taught mathematics at a gymnasium in Ljubljana for twenty-three years. In his first years in Ljubljana, he worked with physicist and director Mitteis. Soon after Nejedli, the mathematician and physicist dr. Jakob Rumpf from Graz arrived in Ljubljana. So, mathematical sciences were extremely well covered. Together with them, the supplied teacher Zindler has taught for a while at the Ljubljana grammar school. He published a discussion on arithmetic and number theory later in the Grammar School Senj in 1870. He described a new theorem on the connection of periodic decimal fractions with ordinary fractions. Later, Nejedli's closest collaborator at the Ljubljana Gymnasium was Matej Vodušek, who published interesting mathematically well-supported research of theoretical astronomy in gymnasium reports and books. Vodušek was a professor of classical languages; before him the professor of classical languages Karl Grünwald has successfully dealt with astronomy in Ljubljana, but more with observation than with theory.

In the Ljubljana Gymnasium Reports, Nejedli published numerous discussions on algebraic analysis. In 1863 he dealt with Euler's procedure for solving indeterminate equations of the first order. In 1865, Nejedli supplemented Močnik's treatment of Cauchy's methods with a discussion of Budan-Horner's algorithms for solving numerical equations of higher orders. Ferdinand François Désiré Budan de Boislaurent (1761 Haiti-1840 Paris) and William George Horner (1786 Bristol-1837) published their results half of a century earlier.

In 1868 Nejedli expressed algebraic partial fraction expansion of a rational function as a sum of a polynomial and one or several fractions with a simpler denominator (Zerlegung in Partialbrüche). In 1870, he wrote about multiple and arbitrary values of a definite integral (mehrfachen und willkürlich Werte einiger bestimmter Integrale), and in 1874 he discussed the square equation.

In 1882, he published his last discussion of the theory of perception, which of course made him more profoundly involved in philosophical sciences. A similar philosophical work about

natural historical materialism was published by his associate new supplied professor of physics, mathematics and natural history with PhD obtained in Strasbourg Heinrich M. Gartenauer in the Ljubljana gymnasium report in 1878. It was commented by the famous Wallentin in Viennese referenced anthology of comments on Habsburgian school reports. The connection between mathematics and philosophy has a long tradition in Ljubljana. The best Nejedli student in Ljubljana was Franc Hočevár.²²¹²

As a young gymnasium student, Hočevár attended physics lectures of Heinrich Mitteis until 1866. Then, a famous meteorologist Mihael Wurner returned to the classical gymnasium in Ljubljana to teach in 1868/69-1887/88 and became Hočevár's professor of physics in Hočevár's final high school years. Wurner studied natural science and mathematics in Vienna at the same time as Jožef Stefan between 1853-1856; there he became interested in new vacuum techniques in the study of molecules and meteorology, which he also transferred to the student Hočevár. Finally, Wurner's mind deteriorated because of his sixteen years younger fiancée Ana Pogačnik or because his naughty students, or both.



Figure 18-18: Hočevár's portrait (* 1853; † 1919).

²²¹² Razpet, 2009, 136.

18.3.3 Study in Vienna

Following the (educational) example of his teacher Wurner, Hočevar studied at the University of Vienna at Stefan and Boltzmann's class. Boltzmann was named Moth's successor as a full-time professor of mathematics at the University of Vienna on August 30, 1873, as opposed to his competitor for the Viennese chair Anton Winkler from Prague. Boltzmann retained the Viennese chair until 1876. In the spring semester of 1874, he taught three hours a week on differential equations and two hours a week on mechanical theory of heat; in the latter case, the study of heat transfer through a vacuum paved the way for the only physics law named after the Slovenian, Boltzmann's teacher Stefan. In the autumn semester 1874/75, Boltzmann lectured five hours a week on the differential and integral calculus, while in the next semester he taught three hours per week the number theory and two hours per week higher analysis. He continued his lectures on the integral and differential calculus in the next semester, adding to them the exercises in the mathematical seminar. Boltzmann confirmed the dissertation which Hočevar had prepared at the Viennese Technical College in Anton Winkler's class.²²¹³ It was one of the few mathematical dissertations under the umbrella of the physicists Boltzmann.²²¹⁴

After his doctorate at Boltzmann's class in 1875/76,²²¹⁵ Hočevar became Winkler's assistant at the Viennese Technical College. Shortly after Hočevar, the other Lower Carniolan (Dolenjec) Ignac Klemenčič from Trebnje received a PhD at Boltzmann with a study of the behavior of glass after the relief of burdens of force on glass in 1879.²²¹⁶ At that time Boltzmann was once again a professor in Graz.

Under the influence of Boltzmann and Stefan, Hočevar insisted in the publication of his physical papers with vacuum experiments in the early 1880s, especially after moving from the position of a Viennese assistant to the work of a gymnasium professor in Innsbruck. In Innsbruck, he had an enviable cabinet of physics available, where he designed several high-profile experiments with the

Wheatstone's bridge, Holtz's electrophorus and Geissler's vacuum tubes. He wrote mathematical-physical discussions about the gamma function, Varignon's theorem and Hamiltonian, and after 1882, except some pedagogically oriented thoughts, he devoted himself to pure mathematics. He began his research of vacuum techniques and electricity upon the opening of the International Exhibition in Vienna in 1873 and completed it a decade later during an even more important third International Electric Exhibition in Vienna in 1883, which was technically and scientifically led by Jožef Stefan.

18.3.4 In Tyrol and Moravia

From 1879 to 1891, Hočevar was professor at the gymnasium in Innsbruck, where he was habilitated as a private assistant at the university in 1883. His acquaintances helped a lot.²²¹⁷ The support of the professor of physics Pfaundler enabled Hočevar's high-profile publications at the Viennese Academy. A decade later, the Innsbruck University Chair of Physics of Pfaundler's successor, Ernst Lecher, was taken over by Hočevar's Lower Carniola neighbor Ignac Klemenčič in 1895. In 1882, Lecher inspected Kirchoff's and later Stefan's radiation laws in Innsbruck and in Stefan's Viennese institute. Thus, Innsbruck of Hočevar's and Klemenčič's days was in fact one of the most important centers for the use of new vacuum technologies based on a long tradition, since the instruction in Innsbruck, both at the middle and at the university level, was successfully led by the Jesuits who acquired the physics vacuum cabinet devices in the middle of the 18th century. Among the Jesuitical students in Innsbruck was even a future Habsburg emperor Leopold I. Klemenčič later departed to Innsbruck just like Hočevar, since there was initially no bread for either of them in Graz. The academic chairs in Graz were particularly politically important at that time because of the emerging contradictions between the Germans and the Slovenes, so, that the determined Slovenian could not easily get a job at the University of Graz. In 1891, Hočevar became an associate professor of mathematics at the German Technical College in Brno. In 1894, he was promoted to full professor. Already the following year in 1895, he was called to the Graz Technical High School, where he taught

²²¹³ Höflechner, 1994, 1: 38, 46.

²²¹⁴ Boltzmann, 1994, 1: 46; Dick, Kerber, 1993, 35.

²²¹⁵ Razpet, 2009, 136.

²²¹⁶ Razpet, 2009, 137.

²²¹⁷ Razpet, 2009, 137.

mathematics until his death.²²¹⁸ He received the chair even though the former professor of physics and headmaster of Ljubljana Grammar School now Secretary-General of all universities state counsellor Johann knight Kleeman (Kleemann, 1808 Černovice (Tschernowitz) in Bohemia probably in Brno-City District–1885 Vienna) had explained to Boltzmann and a Viennese PM Fran Šuklje several years earlier that Klemenčič would not get the position of Boltzmann's successor on the Chair of Physics at the University of Graz as a knowledgeable Slovenian; such a nomination had great political weight in the uneven balance between German and Slovenian nationalists in the city. Instead of Klemenčič, Pfaundler achieved the position in Graz in 1890/91. Pfaundler was very close to Hočevar, as Pfaundler presented his physics discussions at the Viennese Academy. Soon Pfaundler was followed by Hočevar, although not at the university, but on Technical school. Hočevar has been the Dean of the Faculty of Mechanical Engineering in Technics school for many years; just before his death, he received the official honorary title of the imperial court councilor of the empire, which was in fact a great honor in those once noble times. In other circumstances, that high honor would open the way to Hočevar's noble title, which lost its meaning and became publicly forbidden in Austria after the WW1.

In 1881, Hočevar published in the Reports of the Innsbruck Gymnasium a discussion on combinatorics and on the theory of divisibility of integers. From 1876 to 1907, at the Viennese Academy, he published many papers about the Differential and Integral Calculus, which he learned from Boltzmann. He wrote three more discussions on algebra, and one on the each of related fields of theory of numbers, combinatorics, series, and analytic geometry of space.

He published a lot in Monatshefte für Mathematik und Physik, much like Plemelj did later. He was thinking about a whole range of areas spread from high school mathematics to mechanics and electrical engineering, but above all about differential calculus, algebra, number theory, numerical analysis, analytical geometry of space, infinite series and products.²²¹⁹ He mainly excelled with writing textbooks; from 1886 on, he covered

all areas of mathematics for with different types and levels of secondary schools. David Segen prepared Hočevar's textbooks for Croats, while the professor of mathematics and physics at the First Grammar School Sarajevo Tomislav Bosutić did the same for the Bosnians. Both were used after the First World War. Due to difficulties in introducing Slovene language in Habsburg secondary schools the authorities did not publish any Slovene translations of Hočevar's textbooks before 1910, while later the competitive textbook of Močnik prevailed.



Figure 18-19 : A sketch of Gervais' Montpellier tools and Hummel's devices for improving the quality of beer and wine in Franciscans' library of Ljubljana, written on the skin of thirsty Ljubljana lovers of Styrian wines (Gervais, Hummel, 1821, 13, 19-20, picture at the end of the book). From 8. 4. 1822 to 1830 Hummel held ten years privilege for his invention of maintaining alcohol spirits in H_2CO_3 acid, while the fabricant Vinzenz Huber of Germignana got similar privilege on 24. 6. 1822-1829. The co-owner of Diana Baths (Mitinhabers des Dianabades) in Leopoldstadt of Vienna the painter of miniature portrait, the first efficient Viennese architect, lithographer who escaped from the French revolutionary terror Karl Ludwig Hummel de Bourdon (1769 Besançon in France, † 23. April 1840 Leopoldstadt 9 (2, Obere Donaustraße 81, today Numbers 93-95) received another privileged patent granted for five years for his apparatus designed to destem and crush the grapes in the same time (Weintrauben zu gleichen

²²¹⁸ Razpet, 2009, 137.

²²¹⁹ Razpet, 2009, 139.

zeit abzubeeren und zu zerquetschen) on 25. 8. 1822-1827. From 30. 9. 1824 to 1833 he held a patent for his machine joiner of timbers (Tischlerhölzer). Carl Hummel set up a device for the improved fermentation of wine and beer and he was granted the imperial privilege in 1821.²²²⁰ In the distillation boiling plant, he used gaskets and receivers typical of the then vacuum and overpressure processes, and in December he made experiments with beer.²²²¹ He used the successes of the French inventor Miss Elizabeth Gervais at the Montpellier College of Science at the end of October 1819. A little more than a year after the invention of a lovely Frenchman Gervais' twenty inches high apparatus, Anton Albert baron Masten has already approved the use of her achievement at the Styrian agricultural society in Graz on 28 March 1821. Of course, all Ljubljana lovers of noble drops with Franciscans included immediately obtained a well-informed and useful booklet reprinted in Ljubljana. The first Diana Bathes bad on the Vienna Danube Canal was built between 1808 and 1810 by French-born master builder Charles de Moreau and the Viennese painter Carl Hummel on a plot bought in 1804 and opened on 1 July 1810. The bathhouse in Parisian style offered tubes with heated water from the Danube Canal. After a renovation they offered 68 bath cabins around a garden courtyard for 78 baths, which were filled with heated water in 1830. In 1841-1843 they built the first covered swimming pool on the continent with a steel structure.

Hočevar wanted to introduce the teaching of derivatives and integrals correctly treated for secondary school physics problems according to the ideas of Felix Klein. In his paper entitled Is it good to introduce elements of an infinitesimal calculus in high school or not? Hočevar first studied mathematics teaching at Habsburgian universities, high technical and secondary schools, including the education of professors at teachers preparatory. He proved that the derivative and the integral must be introduced into the function theory; he suggested cutting some of the content of curricula to enable the new ones.²²²²

²²²⁰ Hummel, 1821, 49-56; *Beschreibung der Erfindungen und Verbesserungen für welche in den k.k. österr. Staaten Patente ertheilt wurden (etc.). k.k. Hof-Staats-Ärarialdr.*, 1841, pp. 234 481-482.

²²²¹ Hummel, 1821, 54.

²²²² Hočevar, 1881, 79.

Ninety years and one day after Hočevar's death, his compatriots in Metlika provided a memorial plaque in cooperation with DMFA, Metlika and the Bela krajina Museum Society. They followed the initiative of a Metlika elementary and middle school teacher of mathematics Jože Vraničar, on June 20, 2009.²²²³

18.3.5 *Hočevar on Holtz's Influence Machine and Geissler's Vacuum Cathode Ray Tube*

Basic of the influential machine (electrostatic generator) was designed by A. Hallerstein's Jesuits in Beijing in their vacuumistic and electrical experiments. The European version of the influential machine was first published by A. Volta in 1775, and thus earned him high school chair in Como as he used to be a Jesuitical fan and highly motivated lecturer. In the middle of the Lago Maggiore swamps, Volta isolated the methane gas by vacuum procedures. In 1792 he admired the vacuum experiments of Lavoisier and Laplace in Paris. By the way, he gained an external membership in the Parisian Academy and the Royal Society of London.²²²⁴ During the Illyrian Provinces, Volta's discoveries quickly became established in Ljubljana, since Kersnik's Electrophorus had already been classified among electrical and vacuum devices of his cabinet of physics in 1811.

Another Karl Hummel became Kersnik's collaborator-mathematician on the Ljubljana Lyceum and a full professor in 1837. In 1833, just before he arrived at Ljubljana, he published a paper about a simple electrophorus as a collector of electric charge by friction²²²⁵ in Baumgartner's and Ettingshausen's first journal for mathematical-physical sciences in the Habsburg monarchy. To obtain static electricity, he used cat's fur, and, above all, he was interested in the natural electricity of molecules released by friction in a vacuum.²²²⁶ He named the Leyden jar after Kleist and translated its electricity using the valves developed in vacuum technology. The bottle was insulated with resin and filled with Pfaff's mixture including Venetian turpentine;²²²⁷ Dr. Pfaff

²²²³ Razpet, 2009, 138.

²²²⁴ Segrè, 1986, 197-198; Ganot, 1886, 691.

²²²⁵ Hummel, 1833, 213-235.

²²²⁶ Hummel, 1833, 214, 218.

²²²⁷ Hummel, 1833, 221, 222.

defended Volta's electrolysis theory, and in 1801 he became a full professor of medicine, chemistry and physics in Kiel.²²²⁸ Hummel summarized the operation of the electric battery according to Gehler's textbook,²²²⁹ the research of Georg Christoph Lichtenberg and Lichtenberg's friend Johann Christian Polycarp Erxleben who prematurely died; later Hummel used it in Kersnik's cabinet in Ljubljana. He was interested in the highest possible charge of the Voltaic electrophorus charge, which he measured with the Voltaic electroscope by the golden leaf. He searched for the geometric shape of the electrophorus, which would have the greatest effect. On 3. 2. 1842 in Ljubljana Franciscan Church of St. Mary's Assumption, the member of Carniola Agricultural Society Hummel married Franziska Marquise Gozani (Maria Agnes Elisabeth Gozana (Gozzani) de St. Georges, * 1824). The godfathers of Hummel's fiancé were the father of Fidelis Terpin (* 1799; † 1875), the wealthy merchant Blaž Terpin (Terpinz, 1759 Bled-1836 Kranj) and Bartolome's wife Elisabeth Paulitsch. Blaž was a granduncle and guardian of the mother of the first Slovenian female poet Josipina Urbančič Turnograjska. Hummel's bride-marquise Franziska Gozani was the daughter of the Commissioner for Roads (Strassenbaukomisär) the marquis Johann Nepomuk (* 1782; † 18. 6. 1836) of the Torino-native family and his wife Eve (Eveline, * 1792; † 25. 3. 1872) born Trockenbrot. Their children were also Carolina Leopoldine Elisabeth Franziska (* 2. 3. 1815), Johanna Nep. Katharina Elisabeth Franziska (baptized on August 24, 1818), Ferdinand (Bartholomäus Felix Konrad baptized on 1. 11. 1819) and Guido Josef Fidelis Vinzenz (* 5. 4. 1831), who was the only one baptized in the cathedral of Ljubljana, while the others were baptized in Kranj.²²³⁰ Franciscans of Ljubljana buried both Hummel's father-in-law and mother-in-law. Hummel's bestmen were the court lawyer Dr. Leopold Baumgartner, and the physician Johan Nepomuk Birtzen.

Hummel's brother in-law Ferdinand and his children were the officers and owners of the Volčji potok manor from 1846 to 1882. By so many wealthy connections Hummel left the job in Ljubljana as the new professor of the University of Graz in 1850. He became there the first professor

of physics of renewed University and retained his chair until his retirement on 31 May 1867. After he left Ljubljana in 1850, Hummel lectured on physics at the University of Graz as the predecessor of Boltzmann and Töpler; the latter also developed electrophorus and vacuum pumps. After Hummel's death, his devastating mathematical critique of life insurances was published in Munich.

The Gorizian physicist and Boltzmann brother-in-law Šantel learned Töpler's experimental physics in Graz including Töpler's award winning vacuum pump awarded. However, Töpler got only 1000 marks as half the prize money, because Geissler at the same time invented a potentially even better pump. In their competition for the invention of the influential spinning wheel, Töpler's rival the Berliner W. Holtz provided more sparks with his device, although it was sensitive to moisture and demanded an initial charge. Holtz experimented with his influence machine in Berlin; later in 1869 he lectured on physics in Halle and then he was employed as full professor in Greifswald in 1884.²²³¹ He used a dual electrophorus, which Lichtenberg compiled shortly after Volta's invention. Holtz also used an amplifier (doubler) of the electric power designed by Erasmus Darwin's friend a pastor from Bentley, Abraham Bennett FRS (1749-1799). The Italian turned Englishman Volta's correspondent Tiberius Cavallo first placed the electrophorus' plates perpendicular to one another in the form of amplifier, while the Englishman Nicholson's increased the efficiency of plates by the silver coating; Žiga Zois read Nicholson's book on Breg in Ljubljana, where he often hosted the professor of physics Kersnik. Volta's younger colleague, the physicist Giuseppe Belli, made a rotating electrophorus in 1831 and published his discovery in Venice. In 1865 and 1867, the professor in Estonian Dorpat (Tartu) later transferred to Graz August Töpler proposed his improvements. In 1869, Poggendorff developed Holtz's ideas into the compiled the ancestor of the modern dynamo of Zénobe Théophile Gramme.²²³² Töpler used his spindle to trigger a meter of long electric sparks at a world exhibition in Paris.

²²³¹ Rosenberger, 1890, 803.

²²³² Rosenberger, 1890, 802-803; Holtz, 1865, 126: 157; Poggendorff, 1865, *Ann.Phys.* 135: 469; Toepler, 1866, *Ann.Phys.* 127: 178; Poggendorff, 1869, *Ann.Phys.* 139: 513.

²²²⁸ Rosenberger, 1890, 286.

²²²⁹ Hummel, 1833, 224-225.

²²³⁰ Schiviz, *Der Adel*, page 130, 315, 316.

Unfortunately, the device was broken along the path.²²³³

Holtz investigated the shape of his spark in the discharge,²²³⁴ and instead of the conductor, he used the recently invented Geissler's cathode ray vacuum tube for his discharges as early as in 1854/55. The interior of his cathode ray tube was steadily illuminated by a weak bluish light, similarly as if the electrodes were closer to each other. In the case of a large charge or when it focused small surface, his cathode ray vacuum tube provided enough light to show that the discharge was easily visible even by the daylight.

invented in 1844.²²³⁵ According to the ideas of the Berliner professor of physics at Gewerbeakademie (later Technische Universität Berlin) and at Preußische Kriegsakademie dr. K. A. Paalzow, Holtz made a smaller electrophorus.²²³⁶ The editor of Holtz's discussion, Poggendorff, of course, remembered that he himself had already described a similar device in a monthly academic report, but Poggendorff's *Ann.Phys* magazine also briefly summarized Töpler's type of experiment.²²³⁷

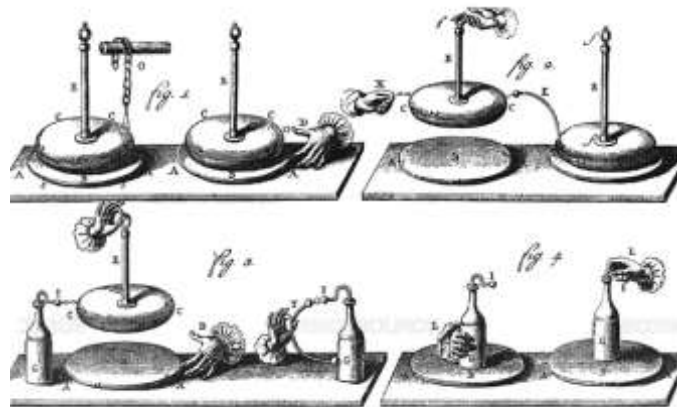

Figure 18-21: Volta's electrophorus (Ganot, 1886, 691).

A decade and a half after Holtz on 31 March 1881, the Innsbruck professor Hočevár completed Holtz's research. Because Hočevár was not an academician, he submitted his work to the Viennese Academy through his sponsor, professor L. Pfaundler from the University of Innsbruck. Of course, Pfaundler was willing to help, as Hočevár had imaginatively described experiments with Holtz's influential machine or an electrophorus, which supplemented the works of Hummel and Holtz; that was the only Hočevár's experimental physics paper in addition to his discussions of mechanics and Wheatstone's bridge.²²³⁸ Hočevár's mentor Pfaundler was a renowned knight of the 3rd grade Iron Crown, a bearer of the Golden Cross with a crown for merit and a member of many academies and societies. He published his own *Compendium der Experimentalphysik*, where he described, inter alia, A. Šantel's invention of a mercury vacuum pump designed with mercury to



Figure 18-20: Hočevár's sketch of Holtz's electrophorus (Hočevár, 1881, 710).

Holtz was also interested in the physiological effects, so, he replaced the vacuum cathode ray tube with the human body without being aware of the potential dangers of warming measured by the thermometer on air of Peter Theophil Riess. Then he replaced the vacuum cathode ray tube with phosphorus, which was even hotter. He examined the chemical effects of the discharge and magnetic measurements with Emil Stöhrer's spiral device

²²³³ Anton Šantel, 2006, 400, 421, 427-428.

²²³⁴ Holtz, 1865, 168, 192/193 (fig. 4 tab. 1).

²²³⁵ Holtz, 1865, 169; Rosenberger, 1890, 281.

²²³⁶ Holtz, 1865, 171; Rosenberger, 1890, 668.

²²³⁷ Holtz, 1865, 157; Poggendorff, april 1865, *Monatsberichte der Akademie*; Toepler (Töpler), *Ann.Phys.* 125: 469.

²²³⁸ Povšič, 1978, 8.

pump air from the vessel in 1883. At the Graz physics institute, Pfaundler immediately photographed X-rays photos soon after Röntgen's discovery.²²³⁹ On 21 January 1896, at a session of the Viennese Academy, he presented X-ray photographs of the needle in the palm for the needs of surgery with illuminations of 15 to 20 minutes²²⁴⁰. In any case, Pfaundler informed Hočevár about the latest vacuum techniques. Above all, his influential connection enabled Hočevár's access to the best lecturing posts in Habsburgian monarchy which was rather unusual for a kid from the remote Metlika near recently disbanded Croatian military Krajina.

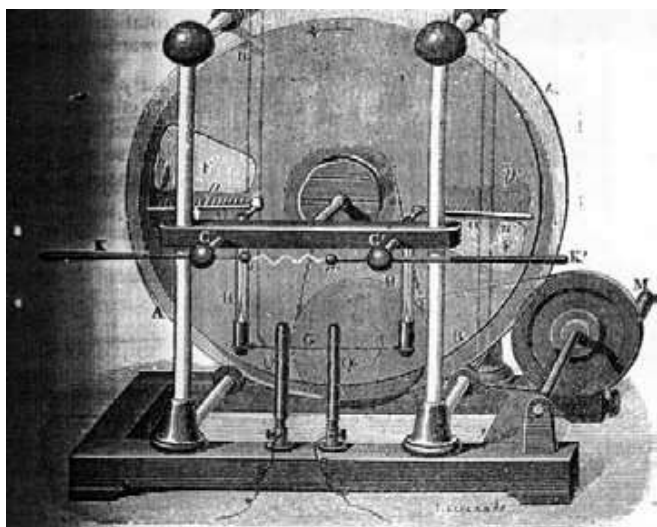

Figure 18-22: Sketch of the operation of Holtz's electrophorus (Ganot, 1886, 69, Holtz, 1865, 192/193 (Figure 2-5, Tab 1))

Hočevár used Holtz's influencer (electrophorus) with unequal discs of 60 cm diameter at the distance of 3 mm.²²⁴¹ In those days, he was a gymnasium professor in Innsbruck, and he used the device in his school lab. Holtz's device was used up until recently in high schools,²²⁴² as its obtained voltages are greater than ordinary electrostatic spinning wheels or batteries of Grove as the discoverer of sputtering according to the measurements of Rudolph Kohlrausch and Stefan's Viennese classmate Francesco Rossetti (1833 Trento–1885 Padova) who excelled as Naccari's doctoral advisor. The electrical current from Holtz's device is almost proportional to its speed

²²³⁹ Šubic, 1896, 187.

²²⁴⁰ Glasser, 1959, 186.

²²⁴¹ Ganot, 1886, 698.

²²⁴² Note of professor Rasto Snoj from Vega's Grammar school (Vegova gimnazija) in Ljubljana.

of rotation. The problem was occasional wetting, which hampered the sparking of Holtz's device, but the Parisian expert of the German genus Ruhmkorff pulled it off with a few drops of petroleum. Ferdinand Philippe Edouard Carré (1824 Moislains in Somme–1900) successfully completed Holtz's friction device and improved its results without any further problems with moisture.²²⁴³

According to Holtz's suggestion, Hočevár put Geissler's cathode ray tube between the plates of Holtz's influential machine and thus observed discharges in a vacuum. Hočevár's description of Holtz's electrophorus with the vacuum Geissler's cathode ray tube received a lot of attention; in the leading Berliner physics magazine, it was valued by Otto Lummer, a rosy young man, who later became famous with his verification of Stefan's law by measuring the radiation of an electrically heated hollow platinum cylinder in a vacuum in Berlin between 1896-1899.

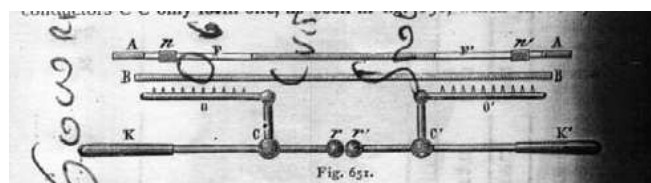

Figure 18-23: A drawing of the operation of the Holtz's electrophorus (Ganot, 1886, 698).

Vlacovich acquired electric power in Koper and Trieste with the generator of the electrician (Georg) Karl Winter,²²⁴⁴ who first compiled his plates as an improvement of Adolph Poppe's (1847) and Holtz's inventions with his smaller design in Vienna on 26. 2. 1847 and 1869. Baron Moriz von Ebner-Eschenbach (1815 Vienna–1898 Vienna) as professor of physics and chemistry at a Viennese engineering academy (militärischen Ingenieur-Akademie) bought Winter's bigger design for his academy as presented on 16. 4. 1847.²²⁴⁵ Winter's bigger design was on sale by A.

²²⁴³ Ganot, 1886, 199, 700-702.

²²⁴⁴ Vlacovich, 1862, 57.

²²⁴⁵ Hočevár, 1881, 179; Winter, Karl, Ein Neuer Electrophor-Apparat. *Bericht über (Bericht ueber) die Mitteilungen von Freunden der Naturwissenschaften in Wien* (ed. Wilhelm Haidinger). 2/10: 196-197, 2/12: 305, 315-316; Winter, Karl, Ueber die Konstruktion eines Allgemeinen Electrophor-Apparates, *Dinglers Polytechnisches Journal*. Erster Aprilheft 1848, 29/108/VIII: 13-14; österr. Blätter für Literatur und Kunst vom 12. Jun. 1847.

Pichler's Witwe & Sohn Lehrmittelanstalt in Vienna in 1875-1933. In 1852, Robida bought Winter's tool for his cabinet of physics in Klagenfurt, where he taught Josef Stefan. Hočevar immediately obtained Winter's improvement of Holtz's device in Innsbruck, as did S. Šubic in Pest. The vigorous development of the electrophorus in

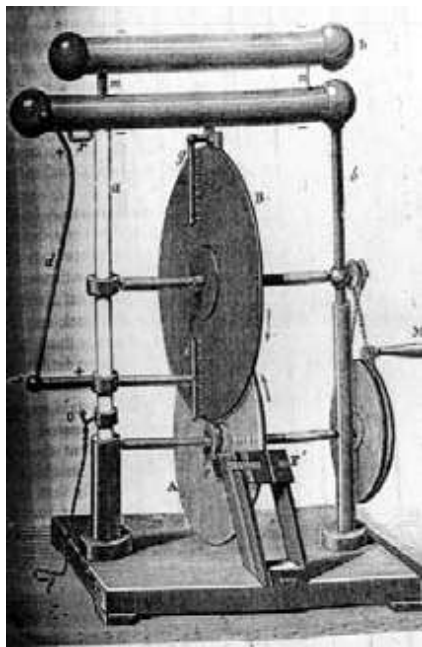

Figure 18-24: Carré's improvement of Holtz's electrophorus (Ganot, 1886, 701).

the Hočevar's days was crowned by Van de Graaff's generator in 1931; between 1953 and 1957, Van de Graaff's generator was assembled at the Jožef Stefan Institute in Ljubljana. Winter provided the largest generator of its kind as the final development of plate frictional electrical machines. His glass plate has a composite axle of glass and brass. It is supported on the brass side by two glass pillars, and on the glass side by a stout wooden one. In this way, strength of construction is combined with efficient insulation. The plate is rubbed by two cushions in a mahogany frame supported on a glass stand. The most noteworthy construction feature is the two large "inductor" rings coated in gold foil and insulated on glass supports on either side of the machine. One of these acts as the "negative" conductor when connected to the cushions. The other is the prime or "positive" conductor, the glass plate rotating between its ring-shaped collectors. At the front is a brass sphere on an insulated support which could be replaced. At the back Winter put two discharging conductors, one on a cleared glass support, the other on a green glass support. At the prime-conductor side is a very large Leyden jar, protected in an eight-sided glass and wood case. Two long wooden rods, terminating in hooks and coated in gold foil, are suspended from the rings that were probably used to connect the various parts of the machine together. The machine has been heavily restored in the Florentine Lorraine collections. Karl Winter devised this generator type as essential descendant of Jean Baptiste Le Roy's "long spark" machine of 1772. The capacity of this design was augmented by Winter's "inductor" rings, which contained one or more coils of thick iron wire.

18.3.6 Hočevar about Wheatstone Bridge

Vlacovich and Klemenčič among the first Slovenian physicists measured the speed of electromagnetic interferences in a vacuum or in a substance. The first useful measurement of the speed of electricity was carried out by the Englishman Wheatstone in 1834 and 1835. The other important measurements were achieved by the Lower Carniolan (Dolenjec) Klemenčič in 1884 in Graz shortly after Maxwell's discussions on the uniform nature of electromagnetic and light waves in a vacuum. Wheatstone did not mention Vlacovich or Klemenčič, although he published even in French language with his enviable



Figure 18-25: Hočevar's sketch of the Wheatstone Bridge (Hočevar, 1882, 486).

knowledge of Italian and German languages, which was extremely rare among the British electro-technicians of the Faraday's Circle.

In his lectures, Faraday showed his own and Wheatstone's experiments, as Wheatstone's shyness complicated his public appearances, although, of course, he taught his Baker lessons. Once Wheatstone was so afraid of public that he escaped just before his own prearranged lecture; he left a full hall of curious visitors with long noses. Together with Babbage, he condemned scientists who would take part in spiritistic sessions. Nevertheless, in 1880, when Faraday lectured at the Royal Institution, he sat next to a spirit-loving vacuumist Crookes, while the bearded Charles Darwin was placed behind Crookes.²²⁴⁶ Wheatstone and his brother were selling vacuum and other physical devices in London.²²⁴⁷ In King's College, he directed individual students to experimental studies. He tutored some students. He lectured bit, if anything, immensely shy about his small posture. He fluctuated between science and business while by his youthful scientific work he primarily improved vacuum measuring techniques.

By Chladni's designs, Wheatstone obtained figures by strewing sand for the display of knots of waves. In London, Geissler's Bonn co-worker vacuum researcher Plücker examined Wheatstone's device in 1848 and the Jesuit Roman astronomer Pietro Angelo Secchi (1818-1878) did the same next year. At first, Wheatstone measured the speed of sound, and then started to measure the speed of light and electricity. He considered the possibility of two electric fluids and reported his results to the Royal Society on July 14, 1834. The photography pioneer, Assyriologist, and a member of Parliament W.H. Fox Talbot wrote about Wheatstone's achievements for *Philosophical Magazine*. Of course, Wheatstone at Londoner King's College did not have enough room for decisive measurements of any speed of electricity; so, he used the old Parisian Charles-Augustin de Coulomb's mirror design, which was successfully completed by Foucault in Paris again fifteen years after Wheatstone. The ideas of multiplying resolution of human eye switched from Paris to London and back borrowed from the millennia older design of recently enslaved easterners.²²⁴⁸

Hočevar began his discussion on the Wheatstone Bridge immediately after his experiments with Geissler vacuum cathode ray tube put between the plates of Holtz's electrophorus. Even though Hočevar was already at that time in a relatively remote Innsbruck, the atmosphere of anticipation for the announced Viennese Electric Exhibition under the leadership of Hočevar's Professor Stefan of 1883 was already felt. After Stefan's exhibition, Hočevar redirected his scientific talent into mathematics.

18.3.7 Conclusion

In his early vacuum experiments Hočevar upgraded the previous knowledge of electrophorus and early vacuum tubes under the beneficial influence of his Viennese professors Stefan and Boltzmann. Although he later devoted himself mainly to mathematics, Hočevar initially proved an enviable physical talent by his imaginative use of Geissler's vacuum tubes. Hočevar's simultaneous orientation to experimental vacuum technique and pure mathematics was not so unusual as today might seem at first glance, since Geissler's co-worker, Bonn professor Plücker or Fox Talbot, also proceeded in the similar nicest way.

18.4 Tesla's Vacuum Researches

18.4.1 Introduction

Southeast of F. Hočevar's Metlika, the conglomerate of cultures and religions used to produce even more complex minds. Nikola Tesla, a descendant of Dalmatians removed to Croatian Lika, shows the fertility of this religious and ethnically mixed and painfully traumatized Military Krajina. He graduated at the higher school in Rakovac, in the class of Šubic's friend, the physicist Martin Sekulić, who also has his cradle in the stony Lika. Right at the time of Tesla's Matura exams, Poljanska dolina by Škofja Loka native Šubic published his *Telegraphy*, and before it a series of articles in the journal *Rad* (Work) of the Yugoslav Academy of Sciences and Arts in Zagreb, whose member Šubic was together with Sekulić.

During his two years of study (1877-1878) at the polytechnics in Graz with physicist Pöschl and

²²⁴⁶ Bowers, 2001, 191, 213.

²²⁴⁷ Bowers, 2001, 69.

²²⁴⁸ Bowers, 2001, 43, 57, 59, 61, 68.

mathematician Allé, Tesla met the university professors of physics, Šubic and Lower Carniolan (Dolenjec) Klemenčič. Tesla admired Klemenčič's very interesting measurements of speed of electromagnetic waves which Klemenčič designed as a student between 1871/72 and 1875/76 and as a demonstrator at Boltzmann's lab in 1877/78. At the beginning of Tesla's studies, Boltzmann returned to Graz University; he was the most distinguished Central European expert for the new Maxwellian theories. Among the most famous inhabitants of Graz, a mathematician and school supervisor Franc knight Močnik has retired in 1871; Tesla could not pass without Močnik's influence as a schoolboy or even when he tried his luck a lower real school lecturer of religion in his native Gospić. During his studies, Tesla read the work of William Crookes on radiation in the cathode ray tube and on the supposed 4th aggregate state of matter. Tesla visited the elderly Crookes in London three decades later and talked with him mainly about William's inflammatory research of spiritism.



Figure 18-26: A portrait of Tesla's high school professor and fellow of JAZU Martin Sekulić (* 1833; † 1905)

In 1878/1879, Tesla went into hiding in Maribor. He supposedly worked at the technical office of an industrial engineer with 60 guildens of monthly salary, while there were also allowances for successful work. Thus, he became machine engineer and only later beyond the sea – he transformed into an electrical engineer. It can be that young Nikola, even in his Maribor time, was playing hazardous games excessively, gambling for luck or just for his other juvenile irrationalities. That is why he never shouted about that period of his life from the rooftops. Perhaps he found his youthful love among the Styrian folks, who provided his romantic memories to the end of his days. Shortly after Tesla's departure, Maribor as the first in this part of Europe, equipped its public road lighting with light bulbs in 1883.²²⁴⁹ On 24 May 1892, Tesla personally gave advice to the mayor of Zagreb²²⁵⁰ and his assistants on the public electrical lighting of lamps in Zagreb, and he certainly had a good overview of the situation in neighboring Maribor. Despite the interest and prosperity of Maribor's electrical engineers at the time, Tesla could not keep up with Slovenians. Of course, Slovenians can only regret it.

In Maribor, Tesla saved enough to study in Prague, but he did not seriously work on it. Much later he became an Honorary Doctor in Zagreb; similarly, Edison without any official schools came to honorary doctorates. Edison excellently mastered the writing of journalists, but his method was, at least in the beginning, only trial-and-correction of errors, while Tesla put more emphasis on his own thought experiments and loved media even more.

In 1882 in Parisian Edison Company CCE (Compagnie Continentale Edison) Tesla collaborated with Edison's friend Charles Batchelor (Batchellor). Five years earlier, Edison ordered Batchelor to use a conventional air pump for evacuation of the cathode ray tube equipped with a plug of carbon. Due to poor vacuum, the carbon burned there almost as fast as in the air;²²⁵¹ however, under Batchelor's patronage, Tesla for the first time became acquainted with serious modern vacuum experiments.

²²⁴⁹ Information of Andrej Simon Lunežnik, pro-dean for students' affairs Pedagogic faculty of Maribor university.

²²⁵⁰ Dadić, 2004, 12.

²²⁵¹ Edison, 1994, XXXVI, 540-547.

At the beginning of 1883, the CCE sent Tesla to Strasbourg. In the following year a hopeful young man, following the recommendation of Parisian friends and Batchelor sailed to Edison's dreams of New York. So, he went into the New World. In the land of once "wild" Native Americans, he worked for Edison's favor until the spring of 1885. He then set up his own Tesla's street lighting company only a year after the introduction of lighting in Maribor. The following year he completed his own imaginative lighting system with arcs; about it, Slovenian ancestors only read a decade after the invention in their native language: "If we link two metal plates that stand opposite each other with Tesla's currents, then there are very strong electric forces among them. Geissler's tubes, which we bring into such a space, immediately flash off. This behavior of Geissler's tubes enabled Tesla's hope that it would be possible for him to introduce new, all enveloping electrical lighting. In the space that we would like to enlighten in this way, we would insert two opposite walls of a large metal plate and tie them with Tesla's currents. Then, at each end of this space, a Geissler tube would illuminate, which would be freely wirelessly transmitted and put in any place. Sadly, we are still far from this ideal lighting."²²⁵² A dozen decades later the distance is still here ... For how long?

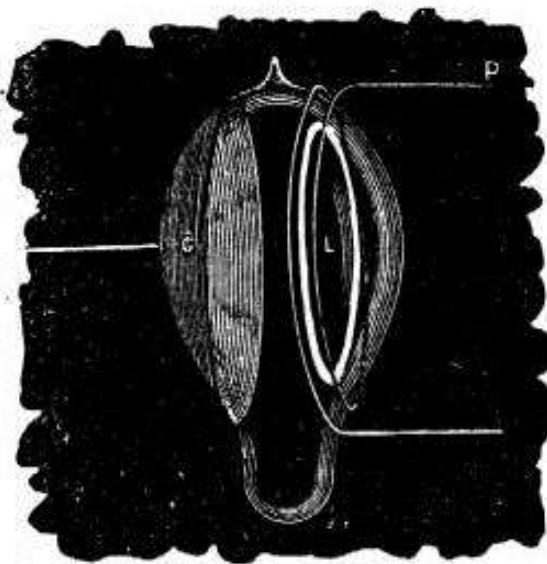

Figure 18-27: Tesla's glass ball of a regular bulb surrounded by one or two turns of the conducting thick copper wire P and the luminous circle L excited by discharge

²²⁵² Dadić, 1982, 305; Šubic, 1897, LXIV.

18.4.2 Tesla's Electrons and X-rays in Crookes's Vacuum

Tesla was, of course, the "predecessor" of many discoveries attributed to others: X-rays, lasers, Marconian radio, electron microscope, induced radioactivity, accelerator of charged particles ... Let's look at the educational story about his "discovery" of the electron in a controversy with a valid declared discoverer, J.J. Thomson. The former W. Thomson's collaborator on submarine telegraphing Thomas Commerford Martin (1856 London–1924) used to be Tesla's friend but turned enemy after criticizing Tesla's

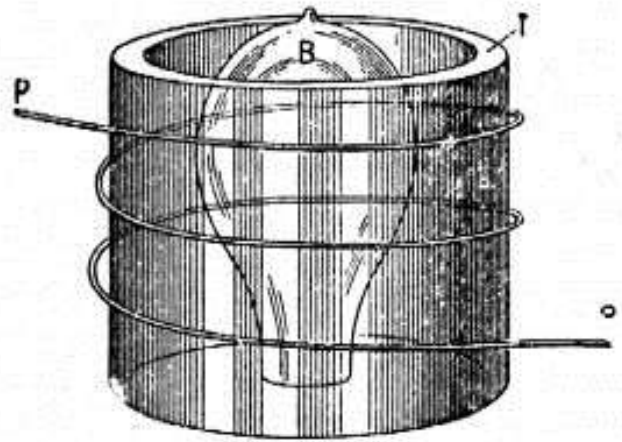

Figure 18-28: Tesla glass tube T around vacuumed bulb B to increase the specific inductive capacity of the medium between the primary and secondary for augmented inductive effect

warlike devil automata on November 24, 1898. On June 10, 1891 Martin²²⁵³ as the editor of New Yorker *Electrical Engineer* published a summary of J.J. Thomson's description of the electrical arc discharge in a vacuum in front of the Physical Society of London printed in *The Electrician* of London. Two weeks later, Martin published similar thoughts of American professor Elihu Thomson.²²⁵⁴ The next week, Tesla added his own pot to the same magazine. At that time, in his New York Laboratory, Tesla investigated the creation of an electromotive force and light emitting in the vacuum cathode ray tube, preferably without electrodes, using a strong induction in a powerful electromagnetic field. Tesla shared his ideas with

²²⁵³ Jovanović, 1998, 11.

²²⁵⁴ Horvat, 1988, 265, 271; Paar, 2004, 38-39.

Alfred G. Braun of the Western Union Telegraph Company. On one side Tesla extended his tube to form a plain vacuum lamp, inserted copper or even gold plated into it and watched the circle of light between the copper and the glass frame. The visual effects were much greater when the copper was closer to the glass, and the the glass appeared to be heated by particles bombarding in a rectangular direction. In experiments with alternating low-frequency currents, the phenomena were attributed to electrostatic effects, while J.J. Thomson's division of electricity in a static and dynamic parts did not make sense at all in this line of circumstances. Thomson even convincingly told Tesla that he did not even read the writings of *The Electrician* about his own speech before the Physical Society of London.



Figure 18-29: Tesla with a field-sensing light in a New York lab during his polemic controversies with J.J. Thomson and Röntgen (Museum of Nikola Tesla, Belgrade).

Of course, Tesla, was a good son of recently disturbed brotherly Yugoslavian nation. So, he didn't remain silent. He replied as soon as Thomson's London defense was noted in Martin's New York newspaper. Tesla completed his paper with a prophetic claim that "the observed phenomenon is a consequence of the movement of small charged particles that collide with the gas molecule at a high speed." Thomson, of course, did not agree with Tesla at the time, but in less than six years he did, because he suddenly announced his own - discovery of the electron. Whoever knows, he knows. The poor Tesla once again stayed with a long nose. In 1894, Tesla and his assistant the Century Magazine photographer Dickenson V. Alley noticed the blackening of the photographic

plates after the discharges of Crookes' cathode ray tube. At the beginning of next year, Tesla's New York Laboratory was burnt to the ground, perhaps with little help or even with some merits of his competitors; nevertheless, immediately after Röntgen's discovery, Tesla continued experiments with reflections and other properties of new rays. On August 1, 1896, and again on August 29, 1896, Tesla's X-rays reflected as tiny small particles to break the charge from atoms.

In his dispute with Thomson and Röntgen, Tesla remained torso; he preferred to undertake research on high frequency discharges in diluted gases, where he had virtually no competitors. From May



Figure 18-30: Undisturbed Tesla in the middle of his lightnings at his laboratory in Colorado.

1899 to February 1900 in Colorado Springs Tesla tested wireless high-power transmission, his second magnificent invention of the engine in the rotating magnetic field of alternating multiphase current. He thought of the earth and the upper layers of the atmosphere as a plate of a huge capacitor with the lower layers of air as an insulator. It resembled a later model of Earth as the electrode of a vacuum tube collecting particles of the northern light (Aurora Borealis). It seems that in his thoughts Tesla attributed to Earth too high electrical conductivity; he liked to put much on his feelings, but they still let him down and astray there. He chose Colorado because the lightnings are as common there as possible, except for the famous summer tornadoes on the Oklahoma plains. Tesla investigated at 120 mm Hg to 150 mm Hg (1/6 to 1/5 kbar) at voltages between two and four million V. In the meantime, on 4 July 1899, he

In the introduction, Mako described the investigations of electrical sparks. In the first part, he reported on the nature of the thunder,²²⁵⁹ and in the other, he discussed the lightning.²²⁶⁰ He approached Franklin's theory of the surplus with positive and the deficit with negative electricity.²²⁶¹ Benjamin Franklin was an influential freemason and at the same time a good friend of Jesuit Bošković when he intertwined those two companies that apparently were not always in quarrels.

Vega and Maffei were certainly proud when they saw how Mako even quoted Valvasor's book *Glory (Die Ehre, Slava)*²²⁶² with a description of two waterfalls in Cerknica Lake. When there was flashing and lightning from the sky, the good old Valvasor heard the donation, as if there were simultaneously banging around the various timpani or kettledrums. The Cerknica fountains seemed to him to be like the caves. In one, he noticed the light, and from the other, a fog accumulated along the storm. Valvasor did not doubt that the phenomenon was caused by electricity, although today it would have been hard to believe him. Bošković's friend, the maker of the first lightning rods in Turin, the Piarist Giacomo Battista Beccaria, reported on similar water vortices as whirlpools in Modena.²²⁶³ Certainly, that description of the inquiries of their compatriot Valvasor finally convinced Maffei, Vega and his classmates to bind their theses of their final exam with the Mako's Book.

In the last twenty pages of the first part, Mako summed up the thunderstorms across Europe. In 1761, the lightning struck at his Viennese home college. From the copper roof it slid down without damaging the wooden casing; then it hit the bell loudly. From there, through the conductor between a solid casing and a roof, it entered the chapel of St. Xavier and finally struck in a silver-plated and gold-plated statue of the Mother of God. In 1770, the lightning hit a small tower of the same college; it traveled through the copper roof, descended through the iron door, and penetrated the rooms.²²⁶⁴ In 1770 the lightning again dangerously

burst, this time in the door of the Viennese Jesuit College.²²⁶⁵ Mako also described the lightning in Venice on May 26, 1752 and on June 18, 1764,²²⁶⁶ the storm in Timisoara on February 1, 1772,²²⁶⁷ and the recent lightning that hit a gilded ball in Berlin on July 20, 1772.²²⁶⁸ The events in Timisoara were certainly reported by then navigation director of Timisoara areas the Jesuit Tobias Gruber.



Figure 18-32: The ships by the seashore painted before the front cover of the translation of Mako's book, bind to the examination theses of the professors Maffei, Schöttl and Tschokl, defended by Vega and his schoolmates in August 1775. The same ships were published in 1772

The former Jesuit of Ljubljana, Biwald, set up the first lightning rods in Styria. Of course, Carniolans did not lag much behind their neighbors; in the continuation of Maffei's mathematical part of the exam the Ljubljana professor G. Schöttl, in his last 38th physical thesis, dealt with the iron lightning rod put on the stick.²²⁶⁹

The Ljubljana Rector Anton Ambschell described the lightning in the monastery church of St. Martin: "... in 1782, the lightning struck three

²²⁵⁹ Mako, 1775, 1-57.

²²⁶⁰ Mako, 1775, 59-125.

²²⁶¹ Mako 1775, 4.

²²⁶² Valvasor, 1689, 50/4: 49; Mako, 1775, 41.

²²⁶³ Mako, 1775, 17, 42

²²⁶⁴ Mako, 1775, 49.

²²⁶⁵ Mako, 1775, 72.

²²⁶⁶ Mako, 1775, 46, 47.

²²⁶⁷ Mako, 1775, 77.

²²⁶⁸ Mako, 1775, 50.

²²⁶⁹ Maffei, Tschokl, Schöttl, 1775, 52.

miles south of Ljubljana in Carniola, crossing the tower of the Church of the Nuns (...) from where it passed through the monastery to the ground". The event triggered a general interest. That is why Ambshell placed the lightning rod from the wire on the tower of a high building near his Ljubljana apartment and thus became the pioneer of modern Carniolan defense against the lightning. In lightning rods, the then obscure observers often saw the novelty of a dubious reputation. Thus, in 1783, the future revolutionary, the lawyer Maximilian Robespierre, defended the French nobleman in the Arras court. The nobleman disturbed by the neighbors and even the mayor himself by setting the lightning rod. The good-natured Robespierre was then a promising man; his fateful friendship with the guillotine developed only a decade later.

In the second part of the book, Mako accepted Franklin's look at the nature of the lightning and the numerous weather phenomena.²²⁷⁰ He described Bianchini's letter (16 December 1758) about lightning experiments at the Devin castle "near the borders of Carniola."²²⁷¹ Even a century later, the professor of physics at the Grammar school of Ljubljana and its later director Mitteis was interested in Bianchini's research; in the high school report he described the dispute between Nollet and Franklin, which, however, did not seem to be very satisfactory to his Viennese critics. Grailich, the predecessor of Jožef Stefan, who criticized Robida a bit earlier, refuted Mitteis in Viennese journal for the review of papers printed in annual publications of high schools and textbooks. In the Slovene national territory, they began to be interested in arc discharges at an early age. The cabinet of physics was not intended for students only. A gymnasium professor of physics between 1853 and 1866, the gymnasium director and for some time director of Real school the Bohemian German Mitteis, also tested his interesting acquisitions in front of the selected company of educated fellow citizens at lectures at the Society of the Carniolan Museum in Ljubljana. The Regional Museum also hosted interesting features. Thus, physicist Thomas Schrey, Mitteis's deputy, supplemented Mitteis's lecture on the development of a stereoscope, showing the latest methods for measuring the magnitude of the electrical spark-on December 10, 1856.

²²⁷⁰ Mako, 1775, 85.

²²⁷¹ Mako, 1775, 93-95.

Mako summed up Bianchini's²²⁷² experiment of 1750 when he stuck into the ground a bolt upright halberd and connected it with a chain. He noticed the illumination known as the "fire of St. Helene" or of St. Erasmus. Bianchini found that the electrical matter from the atmosphere entered the halberd. The experiment lasted only for a quarter of an hour, and then the scared researchers hid themselves under the roof of the Devin castle an hour before the storm. The dry head is still more valuable than a promising scientific discovery. The guardian of Castle was Maffei's godfather Josef Thurn-Hoffer and Valsassina (Hofer, 1681-1775) until 1774 when the Devin along with the castles of Sagredo and Vipulziano took over his younger brother, the count Janez Krstnik Thurn-Hoffer and Valsassina (1699-1783). Thus, Maffei knew Bianchini's work, which in 1754 described the source and the stream of the subterranean river Timavo in the letter to Gorizia guy, Gvido Kobencl.

Mako knew that the sound did not move the airborne particles over longer distances. Therefore, he correctly assumed that the ringing could not effectively persecute clouds that threaten us by the lightning.²²⁷³ Similar views were also put forward by Carinthia native Joseph Herbert, a professor of physics in Vienna, and a co-worker of the Ljubljana rector Ambshell.

In 1778, Mako discussed relatively new electrical experiments, such as the papers published in Hanover in 1761;²²⁷⁴ but he described only a few of his own discoveries. He did not mention Bošković, since Bošković did not publish much about electricity. Mako was one of Bošković's most important advocates, especially regarding the problems of vacuum and infinitely small quantities that the Jesuits learned to solve only with Bošković's physics. Since the Jesuits of Ljubljana were also in favor of Bošković's ideas, G. Schöttl devoted two among his examination questions to Bošković's "famous curve of forces";²²⁷⁵ the selection of Mako's book for the binding of the examination theses was also well expected on Bošković's side.

²²⁷² Mako, 1775, 93.

²²⁷³ Mako, 1775; Dadić, 1982, 1: 355.

²²⁷⁴ Mako, 1775, 91.

²²⁷⁵ Maffei, Tschokl, Schöttl, 1775, 40 (tezi XV in XVI).

18.4.4 Tesla's Contemporaries Explore Arc Discharges in Slovenia

18.4.4.1 Vlacovich

Nicolò Vlacovich's²²⁷⁶ spark was apparently triggered suddenly; in fact, it had a series of successive discharges, as Tesla already knew.

Vlacovich's experiments on the duration of the electric spark independent of the circuit in which spark arose, determined only by the skipped distance,²²⁷⁷ was induced by new thinking. During Vlacovich's research, Maxwell published the first discussions about the similarity of light and electromagnetic waves, which no longer restricted them to the area of the conductor and enabled Tesla's subsequent success.

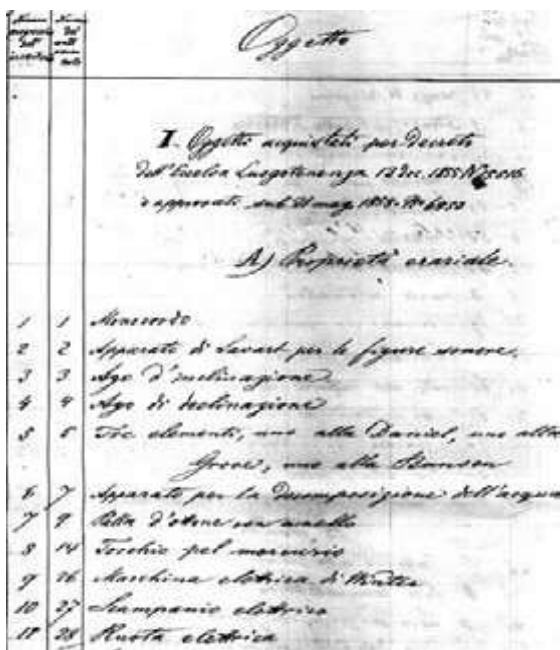

Figure 18-33: The first page of the unpackaged list of the Koper cabinet of physics with devices that started to acquire years 1850. Vlacovich used devices 5-11 to investigate sparks (Vlacovich, Nicolò and others, 1850-1871 (1885), *Inventarioio del Gabinetto di Fisica*, IR Ginnasio Superiore di Capodistria, Koper Urban Archive, Box 10/3).

Vlacovich, of course, intervened far beyond the potential experiments with the claim that the arc discharges consist of a fast sequence of shocks; Tesla later accepted the idea. Vlacovich supposed that the first discharge is the strongest among them

²²⁷⁶ Vlacovich, 1862, 531.

²²⁷⁷ Vlacovich, 1863, 10.

all. Despite the smallness of the entire time of sparking, the spacing between the individual strokes is still much longer than the time that an electrical disorder needs to travel through the circuit with which we make the spark. Vlacovich did not measure this speed, which was first convincingly determined by Wheatstone in 1834 and 1835, followed by Klemenčič in 1884 in Graz. Vlacovich's²²⁷⁸ resistance to the circuit does not affect the sparking length; the problem of arc discharging is still interesting today because, despite Tesla's efforts, we do not yet have the prevailing theory of atmospheric discharges during lightning and thunder.

18.4.4.2 Robida and Šubic

In his research, Stefan's professor Robida participated in the first measurements of the sputtered of metals and the propagation of electromagnetic waves; but the approach of the younger Vlacovich was more modern. Robida initially did not undertake more difficult experiments without suitable pumps and seals; Nevertheless, three decades before Hertz, Robida published his measurements of electromagnetic waves.²²⁷⁹ The first among the Slovenes, Robida sputtered a pointed platinum electrode into a "white round stain from a giant number of platinum grains that took on plates at the higher temperature..."²²⁸⁰ François Napoleon Marie Moigno recommended Ruhmkorff's inductor in collaboration with Cauchy who worked in "Slovenian" Gorizia during Robida's era. According to Robida's view, Moigno should overlook the warming of the positive electrode and the flow of the particles towards the negative electrode. Robida's friend Poljane native Simon Šubic has purchased several Geissler's tubes among electromagnetic instruments for his collection of cabinet of physics in Pest, two decades before Tesla was employed by a neighboring telephone company. Both Šubic and Tesla considered Crookes' findings from 1869. However, Šubic did not accurately describe the proportionality of the length of the dark "Crookes" area along the cathode with the average free path of molecules in gas.

²²⁷⁸ Vlacovich, 1862, 531; 1863, 11.

²²⁷⁹ Robida, 1857, 4; Robida, 1858, 59.

²²⁸⁰ Robida, 1857, 4, 31, 33; Grailich, 1858, 426.

In 1875, Šubic published the first Slovenian booklet on telegraphy, and Tesla, of course, was among its first readers. Until those days, the telegraph has been operating for almost three decades in Habsburg countries including their Slovene parts. In 1846 Bain's telegraph dominated, and later he was forced out by Morse's invention; like Tesla's alternating current for some of the key usages replaced Edison's DC current.

Up to its 17th page Šubic's *Telegraphy* addressed the development and theories of electricity as it suited the telegraphists. He then proceeded to the individual versions of the telegraph and related fashion models.

Table 18-1: Chapters of Šubic's *Telegraphy*, which influenced the first electrotechnical ideas of the young Tesla

- Introduction
- The ways in which the natural powers used in electrical telegraphy were learned 1
- Several main rules for galvanism 8
- Some special notes of the galvanic current used in telegraphy 10
- Carl August von Steinheil's (1801 Alsace–1870 Munich) telegraph with scribing needles 17
- Wheatstone's telegraph on magnetic needles 18
- Bain's telegraph with bells and without them 21
- Morse's electromagnetic telegraph 22
- Apparatus transforming strong domestic electric power 24
- Telegraphic links between remote telegraph stations 25
- Morse's telegraph with color writing 26
- On using Morse telegraph in comparison with others 26
- Abbé Giovanni Caselli's (1815 Sienna–1891 Florence) telegraph imitating faces, called pantile (pantelegraph, universal all-purpose telegraph) 28
- (David Edward) Hughes' telegraph writes telegrams with printed letters 31
- Telephone or telegraph by which singing is heard in foreign places 36
- How and where did the electric telegraph spread 37
- Submarine telegraph 38

- Telegraphy by houses 41
- Electric bells 43
- Operators observing telegraphic signs 44
- Berguet's (the Parisian watchmaker Louis Bréguet) device with an electromagnetic crane and a board 45
- Total base of the house telegraph 47
- House telegraphs shaped like electric watches 48
- Rémond's telegraph with printing guide (Paris 1868) 49
- Hagendorff's house telegraph with a watch showing the letters 53
- A look on common telegraphic bases 55-57.

18.4.4.3 Codelli

Although Idrija and Ljubljana professor Nardin patented a lot in the direction of Tesla's ideas, the Ljubljana baron Anton Codelli is the only Slovenian inventor at least to some extent comparable to Tesla. Alongside Tesla's 170 patents, Codelli also applied for many patents, although he did not have enough experience in the US. Codelli was almost two decades younger than Tesla during the rapid development of electrical engineering, when the new inventions were inflaming each other. Codelli studied cathode ray tubes primarily as a device for establishing his model of spiral television image broadcasting on the US market; he devoted less attention to Tesla's coils.

Since they were moving in the same electrotechnical environment, Tesla and Codelli had many common friends and acquaintances. Tesla corresponded with Adolf Slaby²²⁸¹ in 1901 and 1903. As a professor of electrical engineering at the Technical College in Charlottenburg, Slaby had used German translation of Tesla's work as the basis for high-frequency techniques. He also taught George Count Arco. Arco soon corresponded with Tesla himself.²²⁸² At the same time, the count Arco became a friend and major Codelli's associator within the Berliner Telefunken. Thus, the networks of Codelli were at least indirectly associated with Tesla whom he resembled by his inventive approach. Of course, Codelli was the son of a rich man, but he wasted most his property of Kodeljivo in Ljubljana on the altar of science. A decade after

²²⁸¹ Jovanović, 1998, 13, figure 20.

²²⁸² Pertot, 1962, 103.

Tesla, Codelli also died relatively poorly enough in a faraway country.



Figure 18-34: Yugoslav and American stamps with Tesla portrait from a private collection of writer

18.4.4.4 Conclusions

Tesla worked all year long among the noble people of Maribor. That's not all that binds him to Slovenian ancestors. Many of his studies were related to scientists of Slovenian genus. Of course, Slovenians do not want to assimilate Tesla for the time being, as Americans, Serbs or Croats do successively every now and again. In the future, who knows?

18.5 Tesla's Early Contacts with Vacuum Techniques

18.5.1 Introduction

Geissler's glow discharge tubes filled with dilute gases were calling for new inventions, and basically, they were engaged in whereabouts of the

Prague student of E. Mach's days, Nikola Tesla (1856; † 1943) as a temporary resident of Maribor. Tesla took the first steps in vacuum technique and electrical engineering during his studies at the higher real school in Rakovac near Karlovac with Martin Sekulić (* 29 September 1833, Sankt Michael, today Lovinac in Lika; † 14 April 1905, Zagreb), between 1870/71 and 1873. How did Martin gain Tesla's respect?

18.5.2 Tesla Teacher Sekulić and his Colleagues in Hungary

Martin Sekulić was born in Lovinac in the southern hinterland of Velebit, which today has 90% of the Croatian population; Sekulić family moved from the areas of Senj to Lovinac where they now confess the Catholic faith. The inhabitants of Lovinac had resisted the Habsburg authorities a century before Sekulić's birth in the wider rebellion in Lika; of course, they lost. To punish them the Habsburgian revenge-seekers changed the name of Lovinac to Sankt Michael because of the local Church of St. Mihovil, built in 1704. The penalty was in charge between 1751 and 1861.

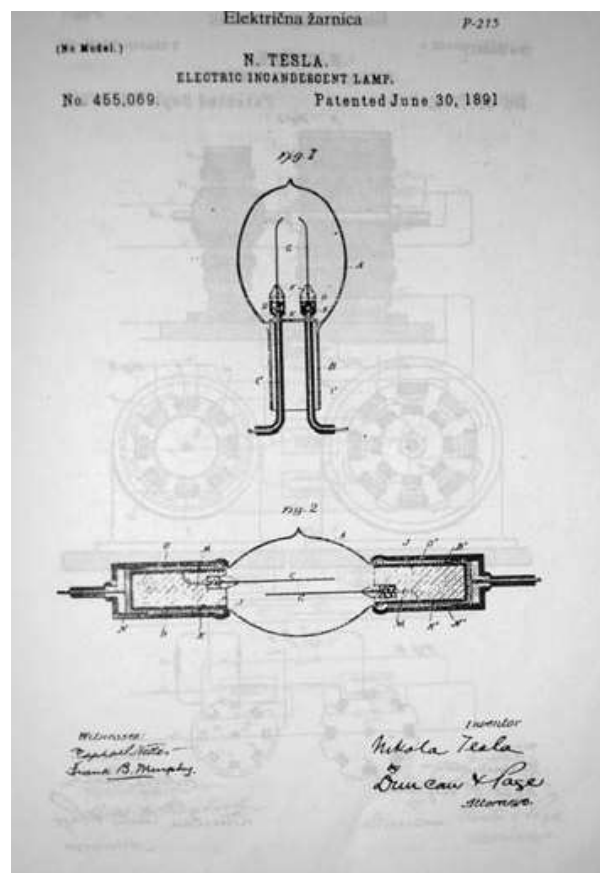

Figure 18-35: Tesla's invention of a vacuum bulb, patented in the USA on June 30, 1891

Tesla's secondary school teacher, Martin Sekulić, began his education in the Military Krajina, after which he was recruited in 1849, in 1852 he joined the Artillery Academy in Olomouc (k. k. Artillerie-Akademie zu Olmütz). He was promoted in 1856 to lieutenant of the 2nd order of light (field) artillery, but he left the service in 1858 without adhering to officer ranks. Later, he completed pedagogical studies of mathematics and physics by acquiring the right to teach at high schools on 20 July 1861. Unfortunately, the Austrian State Archive (Österreichisches Staatsarchiv) does not have information about Sekulić's promotion, as it has, among others, the data of Simon Šubic or Jožef Stefan's studies. Sekulić did not study at the Royal University of Pest, today's Eötvös Lorand University (ELTE) in 1858/59, according to an archive book that mentions students from 1852 to 1871. The University Archives has poor documentation for the period 1852-1859. Reports were kept by the National Archives of Hungary but were badly damaged during the 1956 revolution when data for the 19th century were burned.²²⁸³

Otto Balthasar Petzval (* July 7, 1809, Spišská Belá (Zipser Bela); 28 August 1873, Budapest), brother of the Viennese professor Stefan Josef, studied mathematics and from 1851 to 1857 served as the professor of dynamo studies at Kaiser-Josef-Polytechnikum in Pest, and after 1858 he was a teacher of higher mathematics at the University of Pest (later ELTE). Sekulić was not far away assistant of geometric drawing on the Real school in Pest in 1859/60 and 1860/61 until he became professor on July 20, 1861, and in 1861/62 he was assigned to teach in Rakovac. Josef and Otto Petzval studied at the Royal Academy in Košice between 1822-1825 and 1825-1828 in the class of Buda astronomer the Slovakian Piarist Matej Daniel Kmet (Kmetch, * 1783, Brezno; † 1825, Košice).²²⁸⁴ Afterwards, Petzval brothers studied at the Institutum Geometricum in Buda, where the dean and rector of the university was a Slovak Adam Tomcsányi (* 1755; † 1831), and after 1839 the famous physicist Štefan A. Jedlík lectured there

as a later colleague of Otto Petzval at the Institutum Geometricum of the modern University in Budapest. The professor of Mathematics at the Institutum Geometricum was the Croatian Josef Wolfstein, who taught mathematics at the Academy in Košice between 1803 and 1818.

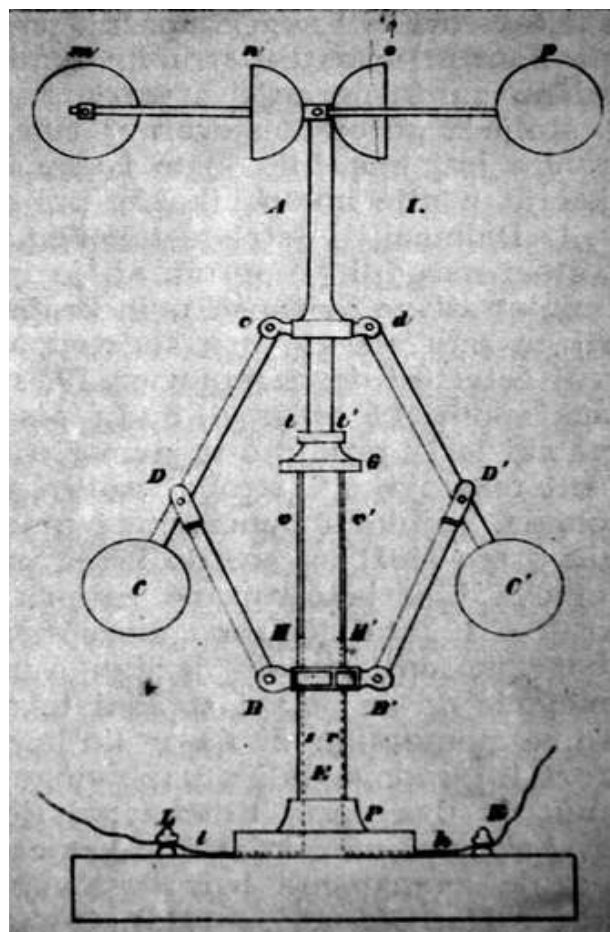

Figure 18-36: The invention for measuring speed of wind for safer driving of trains, which are supposed to stop or slow down while facing the threats of excessive lateral winds. The novelty was described by Tesla's secondary school professor Sekulić at Rad JAZU in 1874 who named it a "Bora-Tool (Burnjak)". The device was probably designed and made several months earlier, after a severe wind caused a local railway accident. "Burnjak" was thus created during Tesla schooling in Sekulić's class in Rakovac, to where Tesla traveled through Slunj in Kordun after his home vacations in Gospić with horse-drawn carriage by the hitchhiking of those days so-called "kirijanje".²²⁸⁵

²²⁸³ Gatti, 1905, 492; Vuković, Valent, 2015, 104; Žubrinić, 2017, 85-86). Emails, from Archive of Eötvös Loránd university, Budapest, by Peter Vezsenyi, 13. 11. 2014. 17:28 and János Hős 9/2/2015 from address info@leveltar.elte.hu
2284

http://monoskop.org/images/2/27/Choma_Milan_Jozef_Maximilian_Petzval_a_Otto_Baltazar_Petzval_Vyznamni_matematici_zo_Spisskej_Belej.pdf, p. 31, 35; Dassenbacher, 1868-1869.

²²⁸⁵ Sekulić, 1874 Burnjak, 27: 225; note of Miran Perhavec from Maribor.

Ányos István Jedlik (Štefan Anián Jedlik, Stephanus Anianus Jedlik, * 11. 1. 1800; † 13. 12. 1895) was an inventor, an engineer and physicist of a Slovakian genus; as a writer of numerous books, he is recognized as an inventor of dynamo and an electric motor in Hungary and Slovakia. After entering the Benedictine order in 1817, he studied at their schools. He taught Benedictines until 1839, then lectured at the Department of Physics and Mechanics at the University of Budapest (Institutum Geometricum) for four decades; Josef Petzval graduated there in 1828. Jedlik became the dean of the faculty in 1848 and rector of the university in 1863. In 1858 he became a correspondent member of the Hungarian Academy of Sciences, and in 1873 he was promoted to extraordinary membership. After retirement, he continued his work in complete isolation in Győr. Pezval and Jedlik greatly influenced Sekulić as a colleagues, teachers, and role models. The university of Technology and economy Budapest (Budapesti Műszaki és Gazdaságtudományi Egyetem, BME) was founded in 1782 as Institutum Geometricum Hydrotechnicum, a unit of the Royal University in Buda. It acquired status of the university in 1871. In 1949, it was reorganized as the Technical University of Budapest, incorporating the former Technical University of Civil and Transport Engineering, founded in 1952. In 2000 it got the present name under the administration of the State Treasury Department.²²⁸⁶

After the Second World War, documents for matriculation and dissertations at Charles University in Prague disappeared for Sekulić's period.²²⁸⁷ Sekulić did not study in Graz or in Vienna, as Bruno Besser explored in Graz. Higher studies in Zagreb were not possible for him because after the ban of the Jesuits only the Royal Academy of Sciences in Zagreb operated from 1777 to 1850 while the University of Zagreb was in charge barely after 1874; so, he did not decide to study in Zagreb. Sekulić is likely to have completed 6 or 8 years of secondary education in the territory of modern Croatia, when the only highest education institution from 1850 to 1874

²²⁸⁶ Email, Krisztina Batalka head of archive, University for technology and economy in Budapest (Budapesti Műszaki és Gazdaságtudományi Egyetem, BME), 12. 11. 2014 14:12: from address kbatalka@omikk.bme.hu

²²⁸⁷ Email, Tuesday, 9. 12. 2014, 14:10:37, doc. dr. philosophy Ivana Čornejová, Institute for history, Karl's university in Prague.

was the law faculty (Regia academia iuris) in Zagreb. Already before the end of his studies, Sekulić was employed as one of two assistants at the real School in Pest in the school year 1859/60. He helped professor Dionis Pospischil's teaching. He assisted the professor Dionysus Pospischil in the first grade of the lower curriculum in geometric design classes (Geometrisches Zeichnen), which Tesla did not like later the real school in Rakovac. Pospischil came to the Städtische Ober-Realschule in Pest in 1855/56 from the service of assistant of that same geometrical drawings at k. k. Schottenfelder Oberrealschule in the 7th Viennese district.²²⁸⁸ Until the merger took place in 1873, the Danube separated Pest in the east bank from Buda on the west bank.

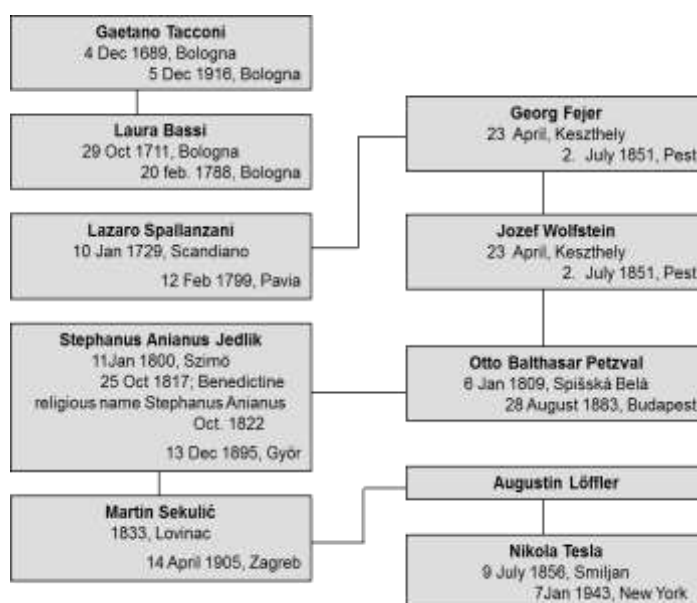

Figure 18-37: Tesla's academic ancestors by his Rakovac studies as teachers of physics (left) and mathematics

In addition to the state (Städtische) real school, the public (Öffentliche) Oberrealschule also operated in Pest. Sekulić's best friend and associate in Pest was a little older Simon Šubic (Schubitz, Subić, Subič, * 28th of October 1830, in Brodeh number 13 in Poljanska dolina near Škofja Loka (Brod bei Lack); † 27. July 1903, Graz). Šubic remained a bachelor male, while Sekulić was already married in Hungary to enable the birth of his son Rudolf (* 1860, Pest; † 10. 10. 1917), later Lieutenant Colonel of the 42nd Zagreb Infantry Division. Soon after Tesla's graduation, Martin again

²²⁸⁸ www.uni-klu.ac.at/elechner/schulmuseum/schulchroniken/gppest_1_18_55.PDF, Retrieved on 17. 1. 2012

married in 1877 and got a new son followed by two daughters. Šubic quickly and successfully completed his studies of mathematics and physics at the Faculty of Philosophy of the University of Vienna between 1852 and 1856. Unfortunately, there was no suitable service for him in Vienna or in his native Carniola.

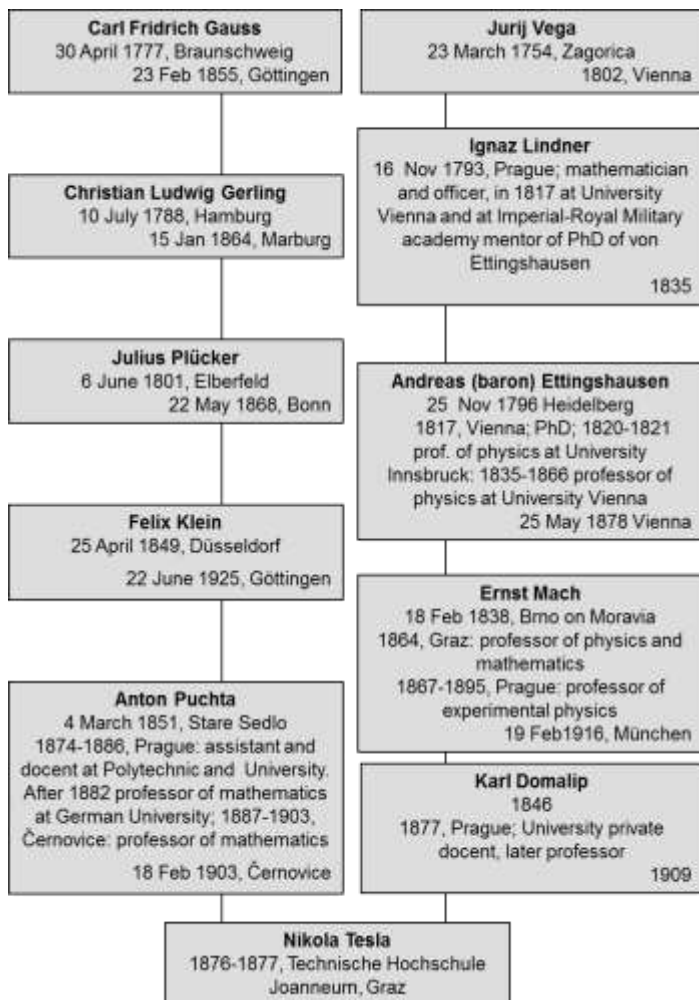

Figure 18-38: Tesla's academic ancestors by his Prague studies as teachers of physics and mathematics. Under their physics education we noted their lecturing services in connection with the famous vacuum researchers Plücker and Vega

Šubic went to Hungary, where on 1 October 1856 he became a trainee at the State Catholic Gymnasium in Buda.²²⁸⁹ He started teaching on October 26, 1856, and he soon earned a complimentary certificate. On 18 September 1857, he was transferred to a higher real school in Pest

²²⁸⁹ Vaniček, 1860 Schematismus, p. 139 a date 25. 9. 1856 was noted as a date of Šubic's appointment in Buda, although he as a supplied professor replaced the ill professor of physics only on 4. 10. 1856 (www.uni-klu.ac.at/elechner/schulmuseum/schulchroniken/gofen1856.PDF)

with order number 15.783.²²⁹⁰ He taught as a professor of physics from 31 October 1857 until the summer of 1861. At the same time, he was employed by the newly established state gymnasium in Pest in 1858/59, where he received two praise certificates for "demanding work" and "basic pedagogical-scientific qualities".²²⁹¹ During his service in Pest, Šubic mainly dealt with mechanics. In 1860, he compiled his first physical discussion in the reports of the Real school in Pest. He wrote about the operation of Friedrich Fessel's rotating machine, which was also briefly reported by Sekulić.²²⁹² From a more geometric point of view, the substitute (suplent) teacher at the Ljubljana high school Luka Lavtar (* 1846; † 1915) added his comments in 1872/73.²²⁹³

In 1855/56, for the state real school of Pest they acquired the aerometer of French chemist and pharmacist Antoine Baumé (* 1728; † 1804), a barometer, a vacuum pump, a Heron's sphere rotating due to a propulsion of sputtering steam, a suction nozzle and thermometers. For the study of electromagnetism, they bought an electrical power machine, a Volta's battery, a magnet, and a magnetic needle.²²⁹⁴ In 1856/57, a gas compressor pump, an additional Heron's sphere and a vacuum pump with two pistons for the voiding of Magdeburg hemispheres were purchased at the state real school in Pest at the same time. In electromagnetic surveys, they have since been given a tourmaline in the clamp for the piezoelectricity long before Pierre Curie and his older brother Jacques described the effect in 1880. They also acquired the Viennese spindle of Karl Winter for friction charge designed in 1847²²⁹⁵ and a lightning producing board, especially important for Sekulić's and later Tesla's research. The equipment was also updated with the electroscope

²²⁹⁰ www.uni-klu.ac.at/elechner/schulmuseum/schulchroniken/gppest1857.PDF, Retrieved on 17. 1. 2012; Programm der städtischen Ober-Realschule in Pest für das Schuljahr 2 (1855/56)–6 (1859/60).

²²⁹¹ www.uni-klu.ac.at/elechner/schulmuseum/schulchroniken/gpest1858.PDF, Retrieved on 20. 2. 2013, Programm des k. k. Staats-Gymnasium in Pest 1858/59; AVA Min CU 31226 ex 1902, p. 15 and 16 (unpaged); www.uni-klu.ac.at/elechner/schulmuseum/schulchroniken/gpest1858.PDF

²²⁹² Sekulić, 1874, 114

²²⁹³ Lavtar, 1873 73–74, 87

²²⁹⁴ *Jahres-Bericht der Ober-Realschule zu Pest 1856*, 50

²²⁹⁵ Winter, 1847, 49.

and two resin plates to display figures named after Georg Christoph Lichtenberg (* 1742; † 1799), which was used by Sekulić a decade later.

Šubic also obtained an electrometer in a bottle of London's pharmacist Timothy Lane (* 1743; † 1807) for measuring the charge of the Leyden jar, invented in the late 1760s to prevent excessive electrifying of the patients during treatments.²²⁹⁶ Tesla later impressed the audience with the spreading of electricity through his body, knowing the skin effect phenomenon that Maxwell predicted in 1873; in 1887 Jožef Stefan supplemented it in the discussion of variable electric currents in thick conductors, with which the effect became decisive for production of vacuum tubes filled with gases. Of course, Šubic also afforded a Leyden jar, an induction machine, two batteries of the Benedictine dean of the University of Pest, Ányos István Jedlik (* 1800; † 1895) with carbon electrodes, an electro-galvanic amplifier - a 400-coin transformer, a twelve-square-inch capacitor and Morse's telegraph,²²⁹⁷ invented quarter of a century earlier. In 1857/58, according to Šubic's order, a device for displaying the aerostatic paradox was purchased on the state-owned real school in Pest needed for the exploration of gases and vacuum. The electromagnetic research was supported by much more demanding purchases, among which excelled: a horseshoe magnet, a compass with dioptra (dioptra, dioptra, δίοπτρα) as an early form of theodolite for measurements of angles, the electric egg shaped as cathode ray tube for multiple discharges with a vacuum pump, with which Sekulić impressed his class with Tesla included a decade later, an electromagnet with Ampère's framework and the apparatus showing influence of terrestrial magnetism on a mobile frame crossed by an electric current discovered by Auguste Arthur de la Rive (* 1801; † 1873) in Geneva in 1820/21.

Especially convenient became a single-pole engine without commutator in the shape of a wheel of Peter Barlow (* 1776; † 1862) with a U-shaped magnet. In 1822 it was designed at the Royal Military Academy in Woolwich a year after the first Faraday's performance. The engine used a single coil to rotate around the fixed axis at low voltages and low torque due to the absence of commutator of Hippolyte Pixi. In 1832 Pixi

designed it according to Ampère's ideas to become a kind of ancestor of the later Tesla's electric motor on alternating current patented in 1887/88. Šubic did not forget either two square-shaped magnets and four pounds of conductors insulated with wool. He bought also the ancestor of the turbine of János András Segner (Johann Andreas Zegner, * 1704, Bratislava; † 1777) from 1750, together with connecting pipes.²²⁹⁸ In 1858/59, the chemistry cabinet was advanced with a purchased gas meter (gasometer), while Šubic brought only physics clock and a tangential compass galvanometer, first described by Claude Servais Mathias Pouillet (* 1791; † 1868) in the Sorbonne in 1837. Therefore, Šubic, with Sekulić's help, has considered numerous textbooks about physics: Pisek's textbook published also with Slovene translations of terminology, Ganot in German translation and the work of a student associate of Justus Liebig and Robert Bunsen, Heinrich Buff (* 1805; † 1878). Šubic commissioned the latest summary of the current achievements of electrical engineering from the professor of physics at the Faculty of Medicine in Paris, Dr. Jules Gavarret (Louis Denis, * 1809; † 1890) in the translation of Rudolf Arendt (* 1828; † 1902), and three volumes of *Lehrbuch der Ingenieur - und Maschinen Mechanik* of Ludwig Julius Weisbach (* 1806; † 1871) from the Mining and Metallurgical Academy in Freiburg.²²⁹⁹

In 1859/60, Šubic with Sekulić's help commissioned an up-to-date collection of electrotechnical innovations: a galvanic flow for rotating movable bodies as a unique electric motor, several Geissler's electrical glow discharges in the tube of diluted gases invented in Bonn two years earlier, an electric gun designed by the Volta's eudiometer, a tubular machine frame for the discharges, the transmission of a galvanic pulse, Charles Wheatstone's (* 1802; † 1875) bridge, a large Smee's battery, several collodium-balloons (collodion) in the form of thin light hollow nitrocellulose layers to observe an electric attraction according to the invention of Louise-Nicolas Ménard of 1846, a galvanoplastic device, a large Schwarz's engine, an electromotor with double coils and magnets beside the commutator designed by Charles Grafton Page (* 1812; † 1868) in the late 1830s. The professor Niccolò Vlahović

²²⁹⁶ Lane, 1767, 451.

²²⁹⁷ *Jahres-Bericht der Ober-Realschule zu Pest* 1857, 42.

²²⁹⁸ *Jahres-Bericht der Ober-Realschule zu Pest* 1858, 73–74.

²²⁹⁹ *Jahres-Bericht der Ober-Realschule zu Pest* 1859, 17–18; Gavarret, 1869.

(Vlacovich) acquired Page's invention for his gymnasium in Koper before the year 1864.²³⁰⁰

Šubic also acquired Gottlieb's device probably designed by professor of chemistry at Tesla's Graz school Johann Gottlieb (1815 Brno-1875 Graz), a vacuum magnetically-deflective recipient of the "galvanic light" (cathode rays or electron by the modern terminology), a device with coils to show the induction law of electric current, the famous Coulomb's torsion scales, four magnetic inductors, coils with twelve rod magnets and an electromagnetic device. For experiments with gases he also afforded Saussure's hygrometer, a psychrometer, a sensor and a preparation for Torricelli's vacuum. He also bought a blood pressure gauge of Charles Nicolas Alexandre Haldat du Lys designed in 1830s, and a centrifuge (Schwungmaschine, Rotationsmaschine, Fessel),²³⁰¹ which was compiled in 1852/53 by former high school professor Friedrich Fessel (* 1821; † 1860) and a pioneering vacuum technician Julius Plücker in Bonn. Three years later, Šubic also acquired it for his cabinet of physics in the Rossau district of Vienna. At the gymnasium in Ljubljana they received the same device only in 1866/67 after paying 4.15 forints of ordinary value, while in the gymnasium in Klagenfurt they got it after Robida's retirement in 1874/75.

In his reports of the real school in Pest, Šubic relied on Lehrbuch der reinen Mechanik of the Sorbonne professor of pure mathematics, Jean Marie Constant Duhanel (* 1797; † 1872) in the German translation of Wilhelm Wagner in Braunschweig published in 1853 and 1858.²³⁰² In the school year 1861/62, Šubic acquired Duhanel's textbook for the library in the Rossau district of Vienna. In his doctoral dissertation in 1861 Šubic did not investigate the operation of Fessel's centrifuge, although he included it next year in an expanded version of the dissertation published in school reports. In 1859/60 in Pest Šubic acquired Foucault's pendulum, which they acquired at the gymnasium in Ljubljana four years earlier.

Šubic acquired in Pest the vacuum tubes of Heinrich Geissler (* 1814; † 1879) three years before the gymnasium in Ljubljana. He and Sekulić were enabled to research the vacuum

technique, which later decisively influenced the young Tesla, not only during schooling in Rakovac, but also in the work for the telephone company Ferenc Puskás (* 1848; † 1884) and his brother Tivadar (* 1844; † 1893), founded in Pest on 1. 5. 1881. The noble brother Puskás studied at the elite Theresianum; Tivadar also matriculated at the Polytechnic of Vienna.²³⁰³ None of the brothers Puskás had attended Sekulić's or Šubic's lessons on the real school in Pest in front of their domestic house. The Hungarian university was founded only in 1872.²³⁰⁴

The comparison between two three-year periods reveals about twice as much new tools with Šubic in charge. He has acquired many more devices for measuring sound, light, and electricity in accordance with Sekulić's and later Tesla's field of research. During his service in Pest, the curator of the Cabinet of physics Šubic befriended Sekulić; therefore, the acquisition of instruments reflects their scientific aspirations, which then directed Tesla's path.

Šubic acquired the following heat-sensing devices at the Cabinet of physics of the Pest Real School: Thermometers with different scales, thermocouple, thermophone for producing tones by infrared radiation as described by B. Higgins' singing flames in which flame heat induced air motion along tubes or jars to produce sound in 1777-1802, a sphere with a ring of different material to demonstrate a thermal expansion of the substance and cryophorus in which the water was rapidly freezing by evaporation due to the Joule-Thomson (1852) phenomenon (Throttling) by the propagation of most gases into the vacuum. Four decades earlier in 1802 William Hyde Wollaston described the events for water vapor,²³⁰⁵ based on previous findings by Tobias Gruber, the brother of professors from Ljubljana.²³⁰⁶ Šubic has received relatively few new devices for teaching about thermal phenomena. To study the mechanics of solids, gases and meteorology, he bought about as many devices as his predecessors in the real school in Pest, although he also devoted his research work

²³⁰³ www.omikk.bme.hu/archivum/angol/htm/puskas_t.htm, www.rubicon.hu/magyar/nyomtathato_verseso/1893_marcius_16_puskas_tivadar_halala/, Retrieved 18. 1. 2013.

²³⁰⁴ Cverava, 2006, 27.

²³⁰⁵ Wollaston, 1813, 71–74; www.wikipatents.com/GB-Patent-359171/improvements-in-refrigerating-apparatus, (patent on 22. 10. 1931, Retrieved on 18. 1. 2013).

²³⁰⁶ Južnič, 2010, 249–251.

²³⁰⁰ Sabaz-Deranja, 1994/95.

²³⁰¹ *Jahres-Bericht der Ober-Realschule zu Pest* 1860, 69.

²³⁰² Šubic, 1860, 17; Hübl, 1869, 203.

Table 18-2: Procurement by branches at the state-owned real school in Pest in the years 1855-1857 before Šubic's and Sekulić's arrival, compared to the period 1857-1860, when the curator of the Cabinet of physics Šubic decided on the procurement

	Solid State Mechanics	Liquids	Gases, meteorology	Acoustics	Electricity, magnetism	Optics	Heat	Total
1855–57	7	2	10	1	17	9	7	53
1857/58	6	1	2	5	11	21	2	48
1858/59	1	0	0	0	1	0	0	2
1859/60	4	2	8	5	18	14	3	54
Total 1857–60	11	3	10	10	30	35	5	104

to these fields of knowledge. Even later, on the real school in the Rossau district of Vienna, Šubic did not acquire more tools for teachings about heat in comparison with other curators of high school physics labs. The lack of interest in the experimental study of thermal phenomena hampered later Šubic's ideas and, moreover, Sekulić's or even by Tesla's theories. After the fall of Bach's absolutism in 1859, the Hungarian conditions radically changed, and with them the circumstances in Croatia within the then kingdom of Hungary. In 1860, Hungarian speech was accepted as an official language, while foreign-speaking officials had to leave Hungary;²³⁰⁷ the same happened to "foreign" professors in Croatia. Together with other "propagators of German civilization" Simon Šubic and Martin Sekulić were expelled from Pest. Šubic went to Vienna, where he helped to establish a lower real school (Kommunal-Realschule) in the Viennese Ninth District of Rossau, together with other deported Hungarian professors. There, Šubic was confirmed as a full-time professor in the autumn of 1861.²³⁰⁸

During Šubic's three-year service in 1861/62-1863/64, Rossau real school had only three lower grades. After Šubic's resettlement in Graz, in the year 1864/65 the Rossau real school got the 4th and the next year the 5th grade. At the time of the foundation of 1861/62, the real school in the Rossau district of Vienna had nine professors; five of them came from the Pest areas. The director of the Pest school and the director of the Rossau real school of Vienna the clairvoyant Rudolf Steiner's benefactor Eduard Walser, gave lectures on Geometry and Construction (Baukunst), the professor of Mathematics, Dionis Pospischil (Dionyz Pospíšil) taught geometry; Stefan Stern

was a professor of German language, a member of several scientific and pedagogical societies doctor Gustav Ludwig Mayr (* 12th of October 1830, Vienna; † 14th July 1908, Vienna) taught chemistry and natural science. Between 1854 and 1855, Mayr worked at the Cologne Department of the Allgemeinen Krankenhause in Vienna, and between 1856 and 1861 he taught natural science in the Pest, and between 1863 and 1892, he lectured at the Rossau Higher Real school in Vienna. He published many researches of insects in hemipterological frames based on research by Professor J. Sapetz from Rakovac.²³⁰⁹

18.5.3 *Sekulić and other Tesla's Teachers in Rakovac*

Tesla started his schooling at a three-grades lower trivial school in his native Smiljan. In 1869/70 a lower grade teacher Nikolaus Kreković, and the teacher Mathias Sekulić²³¹⁰ taught there; Mathias was probably a relative of Martin Sekulić. Between 1867/68 and 1869/70, Tesla attended a lower real school in Gospić for three years. At the higher (main) elementary school in Gospić, lecturers Anton Knežević, teachers Stephan Ratković and Franz Dubravčić and lower teachers Paul Orešković and Elias Janić taught in 1869/70.²³¹¹ In 1869/70 at the brand new building of the lower three-grade real school in Gospić a freshmen Tesla was taught by later director Ivan Balaško, Joseph Vitasek (Wittassek), meteorologist Johann Jamnički (Jamnicky, † 1881) and Joseph Bukvić.

²³⁰⁹

www.landesmuseum.at/pdf_frei_remote/VZBG_SH_0535-0600.pdf, Retrieved on 18. 1. 2012.

²³¹⁰

babel.hathitrust.org/cgi/pt?id=mdp.39015062383578;seq=871;view=1up;num=867, Retrieved on 19. 1. 2013.

²³¹¹

babel.hathitrust.org/cgi/pt?id=mdp.39015062383578;seq=875;view=1up;num=871, Retrieved on 19. 1. 2013.

²³⁰⁷ Zwitter, 1962, 126.

²³⁰⁸ S. Šubic's letter to K. Glaser on 1. 7. 1899, p. 2 (published in Šubic, 1903, 744-747).

At least since 1866 Tesla's father taught religious instruction on the Gospić Real school, also to his son and Mojo Medić. As the teacher he was officially set up only later. From the foundation in 1860 to 1871, the professor of grammar, Josip Velko (Welko, * 1825; † 1896), governed the Gospić Real school.²³¹²

Martin Sekulić, along with Šubic, left Pest in the summer of 1861; the fall of Bach's absolutism has closed their Hungarian gate, while at the same time Sekulić was permitted to enter the Croatian education at the big door. It was more difficult to introduce Šubic, because Slovene lessons were not as quickly established as Croatian. From 1861/62 Sekulić served on a real school in Rakovac in Military (Vojna) Krajina, which is today in the southern part of Karlovac, outside the fortress on the left bank of Korana. On 28 January 1863, the Emperor increased the lower level real school in Rakovac established in 1851/52 into the high real school. In Tesla's time in Karlovac, there was also a gymnasium, which was led by the Franciscans until 1865, just like in Novo mesto. In the era of Tesla, from 1 November 1871 until 1876, the Slovenian historian Ivan Steklasa (* 1846; † 1921) lectured at the grammar school (gymnasium) of Karlovac, followed by the ill Valentin Mandelc (* 1837; † 1872). In 1882/83, the Real school and the gymnasium were merged into the Royal High real gymnasium of Karlovac to save costs; the economizing was already on the stage.

The Ministry of Foreign Affairs appointed nine lecturers of the higher school in Rakovac on 23 August 1863, among them a teacher of mathematics and physics Sekulić as a librarian, professor of engineering, Croatian language and arithmetic. At the beginning of Tesla's schooling, Sekulić became a curator of the cabinet of physics responsible for assembling electric devices²³¹³ and a supervisor of the school meteorological station; he retained that task after the merger of the school with the gymnasium in Karlovac, which in 1882/83 followed the demilitarization (1871) and the abolition of the Military Krajina on 15 July 1881. During the construction of the new building of the

Rakovac Real school in 1863, a botanical garden was arranged. By the buildings Sekulić set up his tools for meteorological measurements. In 1870, the general of engineering corps Anton Mollinary (Molinari baron Monte Pastello, 1820 Titel in Bačka-1904 Soave by Como in Lombardy) as the newly appointed general commander of the Croatian-Slavonic Krajina donated the Milano-made aerometer for measuring the velocities of winds. It costed 300 francs in gold as he really wanted to excel himself at his new duties. Its inventor was Ferdinand Brusotti (1837-1899 Pavia), who perfected electrostatic devices and received a golden medal for his inventing at an exhibition in Alexandria in 1870. Brusotti designed a new type of moisture meter. Sekulić arranged his own design of clock for it. An astronomical observatory was installed on the roof of the Rakovac real school building, but for one reason or another Tesla was never particularly interested in his own astronomical observations although Tesla supported the highly disputed observations of canals on Mars of Schiaparelli.

In the second half of 1863/64 Sekulić was the temporary director of the newly established higher school. The philanthropic mathematician and physicist Ferdinand Peche (* 1820 Pisek in southern Bohemia; † 1898 Innsbruck) was employed in 1849. Peche was among the first trained Czech mathematicians who came to Croatia to teach. Between 1864-1868, Peche was the director of the real school in Rakovac after Sekulić's short intermezzo. Peche received his Ph. D. in philosophy at the University of Prague and specialized at the University of Vienna as well as at the Polytechnic in Vienna. In 1850, he published on the Integration of elliptic functions in a (impossible) closed form and General solution of the 3rd degree equations with avoidance of imaginary forms in the irreducible case in 1851. In 1851, he passed the teaching examination for mathematics and physics in Vienna and became a high school professor. In 1851, Peche was the substitute teacher in Silesian Český Těšín (Cieszyn) on modern Polish-Bohemian border. In 1854 he got the chair of physics at the Joanneum in Graz and habilitated in the same year at the local University for rational mechanics. In 1856 he worked for the Trade Ministerium as a telegraph official of 2nd class in Serbia, which was mostly then Habsburg Vojvodina. In 1857-1864 he was telegraph officer of the first class in Vienna. In

²³¹²

babel.hathitrust.org/cgi/pt?id=mdp.39015062383578;seq=877;view=1up;num=873,
www.novosti.rs/dodatni_sadržaj/clanci.119.html:280070-Nikola-nece-mantiju, www.cro-eu.com/forum/index.php?topic=35.0, Retrieved 19. 1. 2013.

²³¹³ Sešić, 1996, 57; Muljević, 1973, 331.

1864 as director of the secondary school in Rakovac, Peche led his students to independent designs in the field of actuarial science. In that actuarial field Peche published on Life insurance as a convenient means of providing subsistence to youth, organizing schools and promoting trade in 1867 before Tesla's arrival to Rakovac. In 1868-1889 Peche worked with a wide-ranging lecture program as ordinary Professor of mathematical physics at the University of Innsbruck. He left to the Innsbruck community his house and park for the construction of a poorhouse. Peche could be the best available mathematician for Tesla's early formation, but Peche left Rakovac too early. The use of physics textbook of Majer, lectures and rector-ship of Ferdinand Peche, Löffler and Uhlř testify about the greatest influence of Bohemian mathematical-physics sciences on Rakovac Real School. Even broader, that was a period of expansion of the Bohemian mathematical-technical knowledge in all Croatia and in Ljubljana with Nejedli, H. Mitteis and J. Finger.

At the time of Tesla's education, former professor of economics and natural sciences Sigismund Šoštarić von Letovanićki (Šišman) was the director of the Royal higher real school in Rakovac between 1868 and 1875.²³¹⁴

In 1869/70, besides Sekulić, the Doctor of philosophy Christian Lechleitner lectured in the Real school in Rakovac. After 28 September 1858, Moriz Antolić (Мориц Антолић, Mavro, Moritz, Mavricij, Vid, * 1835 Rakovac; † 1870) taught mathematics and physics in Rakovac. From 26 August 1864, the German Franz Sehr (* 1834 Frankstadt in Moravia) lectured on the German language, geography and history. Since 23. 8. 1863 the history and geography were also taught by Christian Nieper (* 1819 Braunschweig). Since 7. 2. 1862, mathematics and geometric designs were taught by Franz Kreminger (* 1835/6 Pančevo). From 26. 9. 1865, Chemistry and physics was taught by Emanuel Kregez (Kregetz, * 1829 Rakovník (Rakonitz, Rakonic) in the central Bohemia). Since August 21, 1864. Joseph Vitanović (* 1843 Tenja in eastern Slavonia southeast of Osijek) taught Croatian Language. The freehand drawing lectures in Rakovac were entrusted to Carl Pallasman (* 1840 Schlotten in

Bohemia)²³¹⁵ after he arrived from Villach in Carinthia on 18 February 1866. Tesla disliked the teachings of freehand drawings. Adolph Waldau was also in Rakovac while the professor of the natural sciences, mathematics and physics was Johann Max Hinterwaldner (* 1844 Schwaz in Tyrol; † 1912) who replaced Joseph Sapetz (* Všečovic in Moravia). Joseph Sapetz was employed on September 26, 1865 and retained his chair of the professor of chemistry and natural science in 1868.²³¹⁶ Löffler was not Tesla's favourite, probably because of his physical exercises taught with wooden rifles and the trouble he gave Tesla in first semester of math. On August 23, 1863 Catholic catechist Joseph Jagunić (* 1831 Plešivica in Croatia; † 1891) was employed and from 23 August 1863 the Orthodox priest Nikolaus Živković (* 1839 Meminska in Vojna Krajina) taught.²³¹⁷ In 1871, Sekulić, Antolić, Sehr, Kreminger, Kregez, Löffler, Alois Möstl, Joseph Palm, Jagunić and Živković lectured at Real school in Rakovac.²³¹⁸ In 1872, the professors were the same, but without the deceased Antolić and Sehr,²³¹⁹ since Sehr preferred to become a professor at the Marine Lower Real School in Pula.²³²⁰ Among the twelve professors, Sekulić lectured on mechanical engineering and arithmetic in 1871/72.²³²¹

At the end of Tesla's studies in high school of Rakovac, the seventh grade of the Rakovac real school was added in 1871, and in 1871/72 the

²³¹⁵ Verordnungsblatt für den Dienstbereich des K. K. Ministeriums für Kultus und Unterricht. Jahrgang 1870. Wien: Staatsdruckerei, p. 528.

²³¹⁶ Dassenbachre, 1868-1869, p. 171.

²³¹⁷

http://babel.hathitrust.org/cgi/pt?id=mdp.39015062383578;se_q=878;view=1up;num=874 retrieved 19. 1. 2013.

²³¹⁸

http://babel.hathitrust.org/cgi/pt?id=mdp.39015062383560;se_q=887;view=1up;num=881 retrieved 19. 1. 2013 *Kais.*

Königl. Militär-Schematismus für 1872. Wien: Staatsdruckerei, later *Schematismus für das kaiserliche und königliche Heer und für die kaiserliche und königliche Kriegsmarine*);

http://www.archive.org/stream/gradkarlovacopi00strogoog/gr_adkarlovacopi00strogoog_djvu.txt retrieved 19. 1. 2013

²³¹⁹

http://www.archive.org/stream/kaiskniglmlitr01kriegoog#page/n681/mode/2up_p.689 consulted on 18. 1. 2013.

²³²⁰

http://babel.hathitrust.org/cgi/pt?id=mdp.39015062383552;se_q=718;view=1up;num=714 consulted on 19. 1. 2013.

²³²¹ Muljević, 1973, 332; *Siebente Jahresberichte der k. k. Ober-Realschule zu Rakovac in der k. k. Kroatisch-Slavonischen Militär-Grenze 1871/1872.*

²³¹⁴ Son of Josip and the father of zoologist Dragutin Ljudevit Šoštarić (* 1861, Rijeka; † 1890). (archive.org/stream/glasnikhrvatskog1891hrva/glasnikhrvatskog1891hrva_djvu.txt, Retrieved on 19. 1. 2013).

Matura exam was performed for the first time. After Matura, Tesla and other students did not have to pass the matriculation entrance exams for higher level technical schools anymore. At the end of his schooling, Tesla was praised for his knowledge of history certainly narrated by his mother at home, but Tesla was warned of his defective mathematics by the professor Löffler. Tesla soon corrected it, as a problem was plainly due to Tesla's recent illness. In any case, Löffler was much less mentioned in Tesla's memories as compared to Sekulić, perhaps also for Löffler's military-oriented gym exercises with the funny rods used instead of rifles. Tesla clearly disliked that kind of stuff.²³²²

On 24 July 1873, a school supervisor in the Krajina, a founding member of the JAZU the Zoologist Živko Vukasović (* 1829; † 1874) and a principal, under the leadership of the school's supervisor led the Matura exam of Tesla and his seven schoolmates. The exam results were signed by the following professors: Sekulić, Löffler, Živković, history and geography professor dr. Petar Tomić (* 1839 Zabok in Zagorje; † 1918), G. Fridrih, Jagunić, the historian Mijo Brašnić (* 1849; † 1868) who praised Tesla, and the meteorologist Johann Jamnicky.²³²³

Jamnicky's reports on Sekulić's meteorological measurements were later supplemented by Marko Mikšić (* 1847). Tomić was awarded with his doctorate at the University of Graz the next year, but as a premature retiree, he retreated to the Russians' headquarters for some time due to political upheaval. Tomić and another historian Brašnić were not in the military service, unlike the other Tesla's Matura examiners. The maturity exam of Tesla and his classmates of different faiths was signed by the catechists of both Christian churches. Tesla received Matura grades for his behaviour, the knowledges of religion, Croatian language, German language, geography with history, mathematics, plane geometry, natural history, physics, chemistry and freehand drawings.²³²⁴

Sekulić published a lot of his original works outside the school; this must have influenced his

admirable student Tesla, who was, of course, of a different religion as the son of an Orthodox priest. The Catholic Sekulić worked in the administration of Pokupski Falcon (Sokol) founded in Karlovac on 5 July 1885.²³²⁵ Sekulić was its president in 1888. Sokol was a nationalistic liberal Slavic gymnastic organization which copied Czech examples. After his retirement, Sekulić even joined the high politics in 1895;²³²⁶ his hatchet fell in honey during the fifth consecutive elections in Perušić north of Gospić on 19. 5. 1897. Of the sixty registered voters, thirty-eight voted for Sekulić. All Sekulić's fans were in government services, which is why they had to vote for retired professor Martin Sekulić who was the candidate of the Hungarian-fans "People's Party". Sekulić's fans of Hungarians, nicknamed Madjarons of the Croatian-Hungarian Party alias *Horvatsko-vugerska stranka*, did not gain great popularity among the Croatian nationalists, but Sekulić probably joined them because of his previous job and because of his connections in Budapest. Sekulić represented the Croats at the congress of Slavic pedagogues in Prague²³²⁷ and Vienna.²³²⁸ Sekulić was re-elected as a Member of the National Assembly of the Kingdom of Croatia, Slavonia and Dalmatia (*Zemaljskom saboru kraljevina Hrvatske, Slavonije i Dalmacije*) on 9 November 1901. Of sixty-two authorized voters altogether fifty-five voted, among them thirty-six for Sekulić, who remained at a representative Member post until his last days. His competitor was Mark Došen, a trader from Gospić. Došen was a member of the Croatian nationalistic Party of Rights (Stranka Prava) which relied on Croatian historical monarchic rights and is still influential in modern Croatian Politics. In 1861, it was established by Nikola Tesla's generation older alter ego Ante Starčević (1823-1896) who was born in Veliki Žitnik near Gospić just across the hill from Tesla's Smiljan on the north to develop into the father of Croatian nationalism in no way friendly to Serbs of Jews although his mother was born in orthodox religion. After the spring of nation of 1848, Ante Starčević entered the democratic Habsburg politics which soon proved to be just another way to spread the endless religious based hatred across Balkans. Tesla was among the rare

²³²² hrcak.srce.hr/file/75578, Retrieved on 18. 1. 2013.

²³²³ Jamnicky, 1880, 25–32, 99–114.

²³²⁴ www.gimnazija-karlovac.hr/ucenici/nikola-tesla, Retrieved on 19. 1. 2013.

²³²⁵ gimnastika-karlovac.com/o-klubu/povijest-kluba/, Retrieved on 21. 1. 2013.

²³²⁶ Dadić, 1982, 2: 253.

²³²⁷ Horvat, 1941, 54; Šešić, 1996, 57.

²³²⁸ Muljević, 1973, 338.

Military Krajina natives who was able to escape that endless chain of nationalistic hatreds, but he was eventually unable to prevent the same competitive hatred among his fans who will never agree on questions of Tesla's nationality. But, their funny confrontations in media are still slightly better than their recent mutual bombing. The bloodthirsty quarrels for Tesla's supposed intimate national feelings are funny just until armies are not involved, which could happen any day.

Tesla's imagination was attracted by Sekulić's clockwise rotating sphere-balloon nicknamed egg wrapped with a tin-foil (staniol) paper and connected to an electrostatic machine.²³²⁹ The experiment illustrated the spread of waves through a vacuum. Sekulić informally hired an enthusiastic Tesla for his assistant in experimenting²³³⁰ with the inductor of the Parisian German Heinrich Daniel Ruhmkorff (* 1803; † 1877) for stimulating the light emission of metallic powder in vacuum tubes.²³³¹ With an inductor, Sekulić studied spectral differences at several accessible levels of air exhaustion. Tesla especially enjoyed Sekulić's experiments with the rotating sphere-balloon object shaped like an egg in the electromagnetic field which gave to Tesla the idea of his later remote control of Wireless Distance Navigation nicknamed Teleautomatics. Sekulić hired Tesla also because Tesla used to live in the school building of Gospić, where Tesla occasionally had his secret chances to visit the small-school lab even outside the proscribed classes. On 28 February 1863, the later Tesla Graz Professor Pöschl presented to the Styrian Natural Science Society the newly acquired Ruhmkorff's Inductor constructed in Paris in 1851. Pöschl performed the experiments in Geissler's tubes of various fillers, which showed multiple colours stimulated by the ultraviolet and phosphorescent phenomena.²³³²

In the year 1880/81 in Rakovac lab, Sekulić had 277 physical devices and teaching aids. The generous military administration allowed higher salaries with special prizes for lecturers and more expensive equipment than elsewhere in the Habsburg monarchy.²³³³

Tesla wanted to invent his novelties in a stimulating environment. He carefully chose his teaching profession while he realistically counted on the available piece of bread during the demilitarization of his domestic Military Krajina which caused the impoverishment of the centuries-old local men who were accustomed primarily to warfare. Therefore, Tesla decided to study for a teacher of chemistry in Graz, although Tesla later narrated that he studied to become an inventor. The inventor was not an occupation domestic in Tesla's Military Krajina, which proves that Tesla's claim was false as he might have heard some news about professional inventing only later in Graz, Budapest, France, and most of all in the USA.

Sekulić's explanation of the cause of electricity has long been held by Tesla.²³³⁴ Tesla was a respectable pupil, at least in high school, just as Jurij Vega praised his Ljubljana professor Jožef Maffei, even in the glow of Vega's own glory. On the contrary, Carl Friedrich Gauss, as a young man, realized the limitations of his teacher Abraham Gotthelf Kästner, like it happened to Tesla on the Polytechnic in Graz or a little later to Albert Einstein in Zurich.

On 24 November 1874, Sekulić was ranked among the correspondent members of the mathematical-natural class of JAZU in Zagreb, just like Šubic six years before him.²³³⁵ Tesla was chosen as an honorary member of the JAZU in 1896. Tesla was awarded honorary doctorate at the University of Zagreb, which Sekulić certainly liked. Regular members of JAZU were also the inspector Franz Maixner from Zagreb, Michael Kišpatić, and Andreas Mohorovičić. The correspondent members of JAZU were Simon Šubic, the pioneer of Slavic studies Louis Léger (1843–1923) from Paris, Sekulić as retired professor in Zagreb and Mathias Murko as private docent in Vienna in 1900.²³³⁶ Tesla certainly loved to be listed next to the famous chemist Mendeleev among the honorary member of the JAZU after Tesla failed his studies of chemistry in Graz. A lot of professors from Russia, Ukraine, Prague, Vienna and Beograd were among members, but none from Hungary which indicated anti-Hungarian stance of Zagreb academic circles of those times. In Rad

²³²⁹ Pištalo, 2009, 194; Šešić, 1996, 56.

²³³⁰ Pištalo, 2009, 44–45.

²³³¹ Šešić, 1996, 59.

²³³² Pöschl, 1863, 51–52.

²³³³ Muljević, 1973, 336.

²³³⁴ Sekulić, 1877.

²³³⁵ S. Šubic's letter to K. Glaser on 1. 7. 1899, p. 3 (unpaged); Čermelj, 1971, 713.

²³³⁶ *Hof- und Staat...* Wien 1900: 1021.

journal of JAZU, Sekulić published eight scientific papers between 1872-1882; in one he quoted his friend Šubic in 1874.²³³⁷ There were six regular and just as many correspondent members in the class of mathematics and natural sciences of JAZU. At the founding of the Academy JAZU in May 1866, Ljubljana veterinarian-editor Janez Bleiweis was elected among the regular members. In the same class, Josip Torbar (* 1824; † 1900) was a regular member of JAZU in Tesla's time as a professor of physics at a higher real school in Zagreb. He was the editor of the RAD (Work) journal of the Academy of Sciences, and he was president of the JAZU from 1890 until his death. Šubić's friend, the Slovenian zoologist Fran Erjavec, was elected as a correspondent member of the mathematical-natural science class on 23 November 1875. Thus, among the twelve regular and correspondent members of the mathematical-naturalistic class of JAZU, as many as three Carniolan natives were elected in the second half of the 1870s. In 1883, the Viennese professor Fran knight Miklošič was one of three members of honour of JAZU. Zagreb professor Matija Valjavec (Kračmanov, 1831 Srednja Bela by Preddvor-1897 Zagreb) was the only Slovenian among twenty ordinary members of JAZU in 1883 after his election in 1880 while Šubić and Erjavec were the only Slovenes among twenty-three corresponding members including Sekulić in 1883.²³³⁸ Ljubljana did not have its own Academy, but the Zagreb guys at least initially wanted to print their works in Slovene language. Šubić worked closely with the Croatian scientific circles, and especially with his friend Sekulić; one after another, they published the first original physical discussions in Rad. Šubić interrupted his participation in Rad when they no longer wanted to print papers in the Slovene language in 1877.

Tesla attended the lectures about physics, mathematics and gymnastics of Augustin Löffler who was nicknamed Ante by his Croatian friends. The historian Mijo Brašnić taught in Rakovac only between 1872-1874. As a beginner, Brašnić started to teach mathematics in 1872. Brašnić helped the publication of Löffler's New Science of Geometry in the Rakovac school reports.²³³⁹ Löffler also led

the gym for the Firefighter Society;²³⁴⁰ he summarized his system by the Czech model. He first published and spoke in Croatian language about gymnastics.²³⁴¹ He might have been the son of Johann Siegfried Löffler who was since 1822 the first forest director (Wald Director) of the Karlovac Forest Management.²³⁴²

Augustin Löffler was a member of Bohemian mathematical society (*Jednota českých matematiků v Praze*) and later went to Bohemia, so he was probably a Czech by nationality. The mathematics of Bohemia was also promoted in the mathematics and natural sciences section of the *Královská česká společnost nauk* (The Royal Czech Scientific Society) founded in 1770, and in the similar section of the *Česká akademie císaře Františka Josefa pro vědy, slovesnost a umění* (The Czech Academy of Franz Josef for Science, Literature and Arts, founded in 1890. *Jednota českých matematiků v Praze* was proposed by the Prague student, the future Ljubljana professor Josef Finger (1841–1925) and his classmates in 1861 and established next year in 1862 under the German and Czech name *Verein für freie Vorträge aus der Mathematik und Physik* (*Spolek pro volné přednášky z matematiky a fyziky*, The Association for Free Lectures of Mathematics and Physics. In 1862, the secretary of association Finger lectured for the new association *Jednota českých matematiků* under the title *Ueber die allgemeinen Kennzeichen der Theilbarkeit der Zahlen*. Dr. Antonín Grünwald joined them soon as president and gave a paper *Über die Bewegung eines festen materiellen Systems um irgend eine Rotationsaxe unter dem Einfluss der Schwere und des Erdmagnetismus und Anwendung auf Declinations- und Inclinationsnadel* in 1862/63. In 1863/64, Anton Wassmuth (1844-1927) joined the association *Jednota českých matematiků*. J. Dvořák joined in 1864/65, and J. Mach in 1866/67. The

[geometriji/oclc/761528966&referer=brief_results](https://www.geometriji/oclc/761528966&referer=brief_results), Retrieved 18. 1. 2012.

²³⁴⁰

www.archive.org/stream/gradkarlovacopi00strogooog/gradkarlovacopi00strogooog_djvu.txt, p. 78, Retrieved on 18. 1. 2013

²³⁴¹ Löffler, 1874; Löffler, 1879; www.gimnazija-karlovac.hr/povijest-nase-skole/kraljevska-velika-realka, Retrieved on 18. 1. 2013.

²³⁴² hrcak.srce.hr/file/19641, p. 187, Retrieved on 18. 1. 2013; Gränz-Wald-Directionen Carlstädter Wald-Direction zu Thurn bey Carlstadt), with the centre in Turn (Thurn, Turanj) of the south suburb of the city of Karlovac (*Militär-schematismus Des Österreichischen Kaiserthumes*, 1823, p. 412).

²³³⁷ Sekulić 1874, 111.

²³³⁸ *Hof- und Staat...* Wien 1883: 728.

²³³⁹ Jahresbericht der k. k. Ober-Realschule zu Rakovac; <https://vufind.mzk.cz/Record/MZK01-000796619>, www.worldcat.org/title/novi-nauk-o-

professor Dr. Viktor Pierre also helped a lot, while Alois Vaniček, K. Domalíp and V. Dvořák signed a petition for the *Jednota českých matematiků* in 1866. In 1863 the professor J. Kulík donated a large part of his mathematical library to the Society *Jednota českých matematiků* and after his death, the Society received the second part of Kulík's library from his heirs. In 1868, Prague Professor Ernst Mach offered to the Society *Jednota českých matematiků* his lecture room and cabinet for experimentation. In 1868/69 Anton Láska joined the association *Jednota českých matematiků*. In 1869 k.k. police headquarters confirmed the new statutes of the association, which had 69 members and got the new name as the Union of Czech Mathematicians (*Jednota českých matematiků*) with the toponym of Prague omitted. On August 5 and 6, 1870 the Unity of Czech Mathematicians organized the first congress of Czech mathematicians and physicists in Prague. On February 11, 1872, *Jednota českých matematiků* founded the *Journal for Cultivation of Mathematics and Physics*.²³⁴³

Besides Sekulić, Tesla had many other useful role models among the professors of Rakovac real school. For examples, there was a talented Moriz Antolić. He was a son of the head of the normal school in Rakovac, Imbra Antolić (Имбра Антолић, Mirko, * 1801 Nevinac; † 1854) who finished the surveying school in Bjelovar in Slavonia.²³⁴⁴ In 1864, Moriz published ten pages of reflections on diamagnetism in the Rakovac real school reports.²³⁴⁵ The phenomenon has been

²³⁴³ Časopis pro pěstování matematiky a fysiky (Dějiny spolku pro volné přednášky z matematiky a fysiky [History of the Society for Free Lectures on Mathematics and Physics]. In: Houdek, Fr.: Dějepis jednoty českých matematiků v Praze. Vydaný na oslavu památky založení „spolku pro volné přednášky z matematiky a fysiky“ před 10 lety, z kterého *Jednota českých matematiků*, 1872. pp. 9-65, here pp. 10, 22; M. Bečvářová, 2014, The role of Czech mathematicians in the Balkans (1850–1900), *Czasopismo Techniczne* 1 NP (7) p. 41).

²³⁴⁴ www.muzej-koprivnica.hr/wp-content/uploads/2012/11/PZ10.pdf, Retrieved on 18. 1. 2013

²³⁴⁵ Moriz Antolić, Der Diamagnetismus und seine wichtigsten Beziehung zum Magnetismus, *Jahresberichte der k.k. Ober-Realschule zu Rakovac in der k.k. Kroatisch-Slavonischen Militär-Grenze* (1864): 1-10; Franz Hübl, *Systematisch-geordnetes Verzeichnis derjenigen Abhandlungen, Reden und Gedichte, welche die an den inländischen Mittelschulen vorhandenen österreichischen, preussischen und baierischen Schulprogramme enthalten, mit einem Vorworte und einem Anhang, zusammengestellt von*

known for almost a century, but it was identified only by Faraday as the universal characteristic of all substances in 1845, while the matter shows a more pronounced phenomenon in predominantly ferromagnetic and paramagnetic environments. Tesla was very interested in magnetic phenomena and discussed magnetic effects of iron in June 1900.

The professor of natural sciences, of mathematics, and of physics Johann Max Hinterwaldner (* 1844; † 1912) wrote about animals from the Karlovac areas in the reports of the Rakovac real school in 1869/70, 1876/77, 1879/80 and 1880/81. He was initially a substitute teacher (suplent) at the gymnasium in Innsbruck. From 1868 to 1870, he lectured in Rakovac, and then returned to Innsbruck again.

In 1875 Tesla's professor Löffler left Rakovac for Teacher's preparatory school of Budejovice (Budweis, České Budějovice), and he taught in Teacher's preparatory school in Prague later. Mollinary donated 433 florins for building the botanic garden in the Gymnastic-place where Löffler made his famous "gombalište" following the Czech gymnastic model. Mollinary also helped the newly founded bank of Rakovac school. In the second semester of 1871/72 the domestic field-marshal lieutenant von Križ and Brigade-colonel von Hayek visited Tesla's school and spoke to Tesla and his fellow students. The colonel of the Slunj Frontier-Regiment on the south von Georgievics (Đorđević), the members of Karlovac firework brigade, and other distinguished guests visited the final gymnastic show on the end of the schoolyear. Tesla's professor of mathematics-physics A. Löffler led the show. In 1871/72, from thirteen students of final 7th class in Rakovac, eleven were designed for military regiments in Croatia or Military Frontier including a noble fellow Levin Šloser knight Klekovski from Križ in Croatia. Two were designed to comparatively far away Banat Regiment according to their domiciles. The exceptions were two of them who were considered²³⁴⁶ ill like Tesla was pretending to be sick next year, by the arrangement of his father's relatives on high military posts. Tesla could have met Löffler again during his attempted studies in Prague in 1879/80. In 1874/75 in Rakovac,

Hübl Franz, *Prof. am k.k. Gymnasium in Czernowitz*. Czernowitz: Josef Buchowiecki & Comp, 1869, 209.
²³⁴⁶ *Jahresberichte Rakovac*, 1872, p. 29.

Löffler's replacement was the supplier of ordinary professor of 5th class the mathematician Ivan Štrkljević (J. Strkljević, Јохан Штрклјевић, † 4. 5. 1896 Vinkovci) who left for Zemun in 1878 and died as the professor of High Grammar School in Vinkovci. In 1877 in Rakovac, Štrkljević published on Stefan's mechanical theory of heat. He discussed the kinetic theory of collisions as a source of heat in transformation of mechanical work, which was not completely in accordance with Simon Šubic and his friend Sekulić's views.²³⁴⁷ Perhaps Strkljević chose his field of research because he had such a meaningful surname as Strk or trk means something like collision in Croatian and Slovenian languages?

Other mathematician in 1875/76 in Rakovac was Wilhelm Marášek who published on the Solar Astronomy in *Jahresberichte* in that year.²³⁴⁸ It seems that Sekulić was Tesla's favourite teacher, but Tesla eventually paid homage to his professor of physics without mentioning his name. So, Löffler also could be the one, although most people picked up Sekulić. Tesla probably disliked the freehand drawings of Möstl who went to High Real School of Gorizia on November 7, 1872.²³⁴⁹ Tesla also hated the young Gjuro Fridrich's freehand drawings, and Löffler's Gym. Tesla never mentioned Kreminger, Jamnicki, or Löffler. Nikola Tesla's freehand drawings were so awful that his father Milutin Tesla had a lot of headaches every summer when he was forced to persuade his own teaching colleague the professor of freehand drawings to let Nikola Tesla to pass into the next class.

18.5.4 Tesla's Rakovac Classmates

Tesla was not the only genius of his generation in his native Military Border area. Among the students of the Rakovac real school there were already many more talented boys before Tesla. On June 27, 1867, the pupil of the 5th grade of Rakovac real school Franjo Plentaj excelled. His

²³⁴⁷ Johann Štrkljević, „Nešto o uztrajnih momentih i razu“, *Jahresberichte der k.k. Ober-Realschule zu Rakovac in der k.k. Kroatisch-Slavonischen Militär-Grenze* (1876/1877): 27-28, 69.

²³⁴⁸ Wilhelm Marášek. 1876. Ein Beitrag zur Bestimmung der Mitagslinie, *Jahresbericte Rakovac* June 1876, 37-45.

²³⁴⁹ Tesla, 1981, 34, 37; Muljević, 1983; Sešić, Marija. 1996. Мартин Секулић, први Теслин професор физике. *Флогистон*, 4 (1996): 54-82; *Jahresberichte Rakovac* 1872/73 1873/74, Zagreb 1874, p. 53.

paper on mathematical roots was read for the Viennese Academy, which immediately began to send its journals to the proud Rakovac real school.²³⁵⁰ Franjo Plentaj's work was a great step for a small peripheral student few years before Tesla enrolled in the same school. Plentaj (* 1850-1851 probably in Polish Galicia; † November 24, 1901) published his research on extraction of roots with Viennese academy even before he finished his studies in then six-grades higher real school in Rakovac in 1868. As majority of Military Krajina technical talents except Tesla or Ferdinand Kovačević, Franjo Plentaj was unable to pursuit his initial scientific-technical calls because the Military Krajina authorities expected to employ Franjo Plentaj's talents into the more administrative or pedagogical frames. In 1880-1892 Franjo von Plentaj was head of district Bijeljina and in 1885 he arranged the building of monumental new Orthodox church in Brodac with the help of local magnates after Muslim devastations, therefore his memorial plate was put beneath the church door. In 1882, Franjo Plentaj received a Franz Joseph's ordain. He died as counsellor of government and head of Sarajevo district (Bezirk Vorstadt) before Tesla's former roommate Kosta Kulišić was employed in Sarajevo. Franjo Plentaj's probable son was a popular physician of Sarajevo provincial hospital of 4th gynaecologic-obstetrics department in 1900 Dr. Dragan Plentaj who served in Bosnian city Livno later in 1902²³⁵¹ In 1869/70 eighteen students enrolled in Tesla's 4th class. All of them were Croatians, and there were seven guys of orthodox faith among them. In those times the Croatian was not yet a synonym for a Catholic, as also the Orthodox people were noted as Croatians if they were born in Military Krajina or in other Croatian places²³⁵². In those times the authorities did not yet specify Orthodox folks as Serbians. Serbian could mean some connection with Serbian state which was not always friendly to Habsburgs. The authorities rather designated the students geographically, therefore as the guys born inside the territory of Croatia including Military Krajina.

²³⁵⁰ Plentaj, Fran. 1867. Vom Wurzelziehen im Allgemeinen und Wurzelziehen im Besonderen. *Sitzungsberichte der Kaiserlichen Akademie der Wissenschaften Mathematisch-Naturwissenschaftliche Classe*. Wien. 169, 107; *Anzeiger der Kaiserlichen Akademie der Wissenschaften*, mat-nat. Classe 27. 6. 1867 4/18: 154; *Denkschriften der Kaiserliche Akademie der Wissenschaften*, mat-nat. Classe. 4/7: 54.

²³⁵¹ *Hof- und Staat...* Wien 1900, pp. 124, 1047, 1052

²³⁵² *Izvjješće*, 1870, p. 39.

Almost all Tesla's classmates were very successful in his Matura class of 1872/73. On Matura written exam in early July and on oral exam performed later, on July 23, 1873, Tesla's best awarded classmates were Tesla's closest friend Mojsije Medić (Mojo, 1855 Ličko Dobroselo east of Gospić-1939 Zemun), and Nikola Prica. Later Prica taught in Military Frontier Real Schools of Petrinja, Zemun (1881/82), and after September 8, 1882 he was appointed as full teacher of geography, Natural History and chemistry and the curator of chemical cabinet in Rakovac. He was the School-Referent of the Greek-Orthodox bishopric of Karlovac in 1901²³⁵³

Nikola Prica (Priča, * 1853 Korenica; † 1903 Karlovac) was born near the village Prečani which was a native place of Tito's last wife Jovanka. Prica came to Rakovac after teaching at other military secondary schools in Petrinja and Zemun, and he even translated the Czech Zoology just like the Slovenians did in the same era. In Rakovac, Prica immediately published on Clausius' theory of relations among the densities of gases and the masses of their molecules²³⁵⁴ which was in accordance with views of Prica's teacher and now retired colleague Sekulić who supported Clausius' careful avoiding of the hypothesis of ether. Prica described the initial division of chemistry from physics and did not mention deuterium but still relied on old Dalton's theory of atoms. Prica praised Cannizzaro's (1858) way of finding the mass of atoms and disliked the use of Faraday's electrolysis for that purpose.²³⁵⁵ Prica narrated the relationship between the density of gases and the weight of their molecules based on the findings of the then available vacuum techniques in the real school reports of 1883.²³⁵⁶ Prica's kinetic theory was certainly more in the contemporary mainstream while Tesla never abandoned ether.

²³⁵³ *Godišnje Izvješće kralj. Velike realke u Rakovcu u Hrvatskoj za školsku godinu 1881/2* priobčeno ravnateljstvom Zagreb: C. Albrecht, p. 29; *Jahresberichte Rakovac*, 1873, p. 29; *Hof- und Staat...* Wien 1901, p. 1056.

²³⁵⁴ Nikola Prica, O odnošaju između molekularne težine i gustoće plinova (para), *Godišnje izvješće kralj. velike realne gimnazije u Rakovcu* (1883): 4, 16, 38, 42.

²³⁵⁵ *Godišnje izvješće kralj. velike realne gimnazije u Rakovcu* 1883, 3.

²³⁵⁶ Prica (Priča), 1883;

archive.org/stream/radjugoslavensk07umjegoog/radjugoslavenk07umjegoog_djvu.txt, Retrieved on 18. 1. 2013.

Prica used Henri Victor Regnault's measurements, but also the work of Jean Baptiste André Dumas (1800-1884) and the Belgian analytical chemist Jean Servais Stas (1813-1891) who co-discovered the weight of carbon. Prica noted E. Ludvig, H. Sainte Claire Deville and his collaborator Louis Joseph Troost (1825 Paris-1911), Biot, Arago, the organic chemist August André Thomas Cahours (1813 Paris-1891), August Friedrich Horstmann (1842, Mannheim-1929 Heidelberg), Liebig's collaborator the Scottish politician Lyon 1st Baron Playfair (1818-1898), the English chemist James Alfred Wanklyn (1834-1906), B. Bineau as Dumas' collaborator Amand Beinau, German discoverer of isomorphism Eilhard Mitscherlich (1794-1863), Gladstone, Hermann Kopp, A. Kekulé, and Pebal's Graz calculations and experiments. Prica explained the dissociation of gases with the Mechanical theory of heat for molecules in gas but also for atoms in molecules whose velocities grow with temperatures²³⁵⁷.

The other Tesla's classmate Mojo Medić finished the Viennese Polytechnic studies of Natural History and chemistry as Tesla tried to do in Graz. Medić returned as supplied teacher of natural history and physics in German or Serbo-Croatian languages to his native Gospić Lower real school in 1878/79 according to the decision of Graz commission. Tesla worked together with Mojo Medić in Gospić, but only as the replacement of his deceased father as the religion teacher. Medić made a speech on funeral of Tesla's father who used to be Medić and Tesla's religion teacher. Tesla was not on his father's deathbed but might have attended his father's funeral in Divoselo Orthodox cemetery south of Gospić.

According to Prica's publications and Medić's public polemics about the scientific use of Serbian language, they were the early supporters of kinetical theory of atoms and fans of Serbian Piedmont Garibaldi's role in Balkans, at least Medić's published his ideas in that direction. Five student of Tesla's graduating class studied physics-chemistry in Graz or Viennese Polytechnic, and all become professors in Military Border except Tesla, who was unique in failing to finish his studies. Prica, Medić, Kordić and Bielić certainly ashamed Tesla when they returned home with diplomas while Tesla in the same year returned with police

²³⁵⁷ *Jahresberichte Rakovac* 1880, pp. 92-95; *Jahresberichte Rakovac* 1882, pp. 26; Toepler, 1875, L-LI.

guardians from Maribor as a kind of criminal. The humiliated Nikola Tesla tried to find the solution in gambling until his mother offered him all family possession to gamble it away. Other three Tesla's classmates became the post officers, one became military officer, one economist, and the destiny of other two or three is unknown. With about the half of Rakovac Tesla's classmate students making successful inventors-professors carrier in physics-chemistry, Tesla's class was certainly the best of them all. The mathematicians-physicists Sekulić and Löffler, the chemists Emanuel Kregez and Ivan Jamnicki, as well as their final principal teacher the professor of descriptive geometry Franz Kreminger certainly enjoyed teaching there in Tesla's class. Jamnicki was the only one who taught Tesla in Gospić and continued to do so in Rakovac.

On July 23, 1873 Tesla's classmates who passed successfully the Matura Exam were Julius Bartaković as the later officer with 6th class military stipend of 100 florins (fl), and Ivan Bielić (Jovan) as the professor of chemistry, geometry and geometrical drawing and curator of chemistry lab of Real School in Rakovac later after 1881. Tesla's classmates who passed successfully the Matura Exam were also Isak Kordić (Iso, * Kosinj 25 km north of Gospić) with 6th class military fellowship of 100 fl who studied at Viennese Polytechnic to become a supplied professor of mathematics and physics in Real School Rakovac from 1878 until his death on April 22, 1880. Jovan Ljuština became the postal official after his studies in Rakovac with 6th class military fellowship of 100 fl, while Dragutin Šir later also became official of Post. Tesla was noted on 7th place in Matura exams. Tesla's classmates which were not mentioned on Matura exam in 1873 were Eugen Vuletić with 6th class military fellowship of 100 florins (fl) and additional 150 fl, and Georg Bach who received 6th class military fellowship of 300 fl, as well as Gjuro Amšel as later postal official and Julius König who became the economist. In 1873 seven or eight students with Tesla included passed the Matura final exam. We know the names of 12 of all 13 students of Tesla's final 7th class in Rakovac in 1872/73, just one of them is still missing. We'll dig him out on the next occasion. After Tesla left, in 1873/74 in August 1874, Rakovac Matura exam proof with award was given to Nikola Božanić, the later professor of Grammar School in Gospić in 1883. In 1873, Nikola Božanić

received military stipend of 100 fl. The later official Daniel Krga received military stipend of 100 fl, Ivan Modrušan became the maritime engineer, and Adolf Seifert worked as the officer later. The Matura without award was won by Ljubomir Dobrić (later officer), Ivan Glamočlija (theologian in 1883), Luka Momčilović (official), Milutin Pokrajac (official), and Bogdan Sekirica who became a technician but died before 1882. Bogdan Sekirica received the military stipend of 100 fl, and the Real School paid for his flat during his studies in Rakovac high school. In 1872 thirteen students enrolled in Tesla's 7th class. On the end of Tesla's 7th class seventeen students were noted, among them sixteen Croatians and a foreigner. Nine of them were Catholics (Prica, Šir, König, Bach), eight orthodox (Medić, Kordić, Tesla), but nobody was Jewish. The absence of any Jews in Tesla's class was striking, because six Jews matriculated in 1st class in Tesla's final year 1872/73.

18.5.5 *Tesla's Theory of Capillarity*

Šubic's friend August Toepler (Töpler, * 1836; † 1912) was the professor of experimental physics and director of the new institute at the University of Graz from August 1868 to July 21, 1876. On 10 April 1875, Toepler lectured in front of the Styrian Science Society about capillarity. Tesla was not in the audience, but he certainly heard a lot about the event.

In 1756 Johann Gottlob Leidenfrost (* 1715; † 1794) designed strongly illuminated droplets with the illuminated limestone of Scottish engineer Thomas Drummond (Drumond, * 1797; † 1840); the image was projected on the screen with a system of mirrors and lenses to the great satisfaction of visitors. The curved surface of water or mercury was indicated by means of a specially adapted device of Louis Jules Dubosq (* 1817; † 1886). Toepler also used a limestone of a new type for a good illumination of his experiments in the lecture room with the help of Oxyhydrogen (Knallgas).²³⁵⁸

Just when Tesla arrived in Graz, Toepler finished the new university physics institute in Graz. In 1875, Toepler was severely injured by accidental

²³⁵⁸ *Jahresberichte Rakovac* 1880, pp. 92-95; *Jahresberichte Rakovac* 1882, pp. 26; Toepler, 1875, L-LI.

fall from the second floor to a bottom.²³⁵⁹ Shortly afterwards, he went to Polytechnic in Dresden, and Boltzmann replaced Toepler in Graz.

In any case, Toepler's lecture resounded in Graz, although Tesla probably arrived too late to hear him. On January 18, 1876, Tesla, after several months of study in Graz, decided to follow Toepler's example. In front of the society of Serbs in Graz, Tesla lectured like Toepler before him under the title "About capillary tubes". Another member of the society Gjuro Dimić (Ђуро Ђ. Димић) lectured on modern theories of the²³⁶⁰ creation and development of the Earth,²³⁶¹ certainly in Darwinist spirit. In 1898 and 1903, Dimić translated the sacred texts of Athos Holy Mountain (Άγιον Όρος). Tesla associated with Dimić, Jovan Grbičić, Graz University student of philosophy romantic writer later professor of Karlovci Grammar School Paša Marković-Adamov (Паша Адамов Марковић, 1855 Novi Karlovci in Srem-1907), Joca Šević, Milan D. Nikolajević who authored *Uput za čitanje karata i planova. Krokiranje i izvidjanje sa krokiranjem. Sa zasebnim atlasom slika* published in Beograd by Davidović in 1912, and Kulišić. As the group of Graz students, including Tesla's classmates, they helped to establish the Society Srbadija to counterbalance German students' organisations on 19 December 1875. Tesla's lecture was put in the eighth place of the program in Almanac published in Novi Sad in 1884. Novi Sad was a centre of the Serbian minority in the Habsburg Monarchy in those times in 1884. On 10. 4. 1897 N. Tesla of New York donated 100 florins to the Srbadija organization.²³⁶²

Similarly, Mihajlo Pupin received his doctorate from the same subject of capillarity in Berlin in 1889. A quarter century after Tesla, Albert Einstein began his physics research path with capillarity in 1901. In 1906 the same phenomenon was researched by Niels Bohr, who was then also just the beginner.

Tesla's first step in the physics of kinetic theory, vacuum and capillarity was based on the lectures of his professor Sekulić. In the third quarter of the 19th century, two papers on kinetic theory were printed in high school reports of Croatian areas, while Sekulić published on kinetic theory in Rad journal of JAZU in 1874. In 1876 in Rad and in the reports of 1877 the Bohemian A. Laska published yet another discussion with similar content. Ivan Benigar's discussion on kinetic theory, published during his studies in Vienna, can be considered as a Slovenian although he later taught in Croatia; the Croats, of course, jokingly called him "Janez.". The kinetic theory and capillarity were in the air and Tesla caught that wind. The mainstream physics was a natural way of the initialization of the young Tesla even if he began to follow his own ways soon enough.

Among the Austrian researches we also included the born Austrian Ferdinand Redtenbacher (* 1809; † 1863), who, after studying and working for three years at the University of Vienna, moved to Switzerland first in 1834 and then to Karlsruhe in 1841. His influence on Habsburgian places remained significant through his second cousins: the Viennese chemist Josef Redtenbacher (* 1810; † 1870) and the Prague physician and zoologist Ludwig Redtenbacher (* 1814; † 1876). Emil Herrmann (* 1840, Dogneca in Hungary in present-day Romania; † 1925) worked both in the Habsburg monarchy and in Germany. He studied the technique in Vienna (1856-1858), in Pest and in Banská Štiavnica (Schemnitz) in Slovakia between 1859 and 1863. Between 1863 and 1867 he worked in Austria and later in Banská Štiavnica.

Several researchers of kinetic theory, among them Šubic, Wenzel Svoboda as colleague of doctor of philosophy priest Gregor Tuschar, professor,²³⁶³ Czechs Franjo Mathon and Antun Laska, Joseph Polák, Karl Klekler and Julius Puluž (* 1845; † 1918) worked or studied on both sides of the border of Leitha river during the period from 1855 to 1875. Our collection of Austrian papers

²³⁵⁹ Stiller, 1989, 18, 53.

²³⁶⁰ The guy with the same name Gjuro Dimić authored *Opération par voie externe des rétrécissements du trayon* (External operation of the narrowing of the teat) in *Schweizer Archiv für Tierheilkunde* (Swiss Archives of Veterinary Medicine), 1949 February 91(2): 116-119.

²³⁶¹ Mrkić, 2004, 23; Kulišić, 1936, 9, 15; Cverava, 2006, 34-36; Tesla, 1884, 1.

²³⁶² D. Mrkić, 2003. *Nikola Tesla*, Ottawa, p. 3.

²³⁶³ Slovenian, between 1840 and 1842, the adjunct at Lyceum in Ljubljana (Ciperle, 2001, 308-309), between 1850 and 1853, a professor of history and geography at the Ljubljana grammar school (Črnivec, 1999, 427) in Bratislava taught Latin and German languages between 1853 and 1856 (Hübl, 1869, 205; www.bmj.sk/2003/10401-01.pdf, pp. 4-5, Retrieved on 17. 1. 2013, www.arzenal.si/files/knjiznica/books/1184/pdf, p. 153, 186, Retrieved on 2. 2. 2013).

Table 18-3: Researchers of the kinetic theory of gases and vacuum, who worked in the Austrian half of the Habsburg monarchy between 1856 and 1875 inclusive. Signs ZA (for), and PR (against) indicate their opinions about the basic kinetics theory directions. The abbreviation of the newsletters in which these researchers published were noted as: Wien. Ber., Z. Math. Phys., Archiv. Math., Pogg. Ann., Rad, Dinglers Polytechnic Journal, Phil. Mag., Secondary School Report (Iz), Österreichischen Ingenieur und Architekten Vereines Zeitschrift, The Yearly of the Slovenska Matica and Books (K):

Birth-Death	Name and Surname	Work on KT	Opinion on KT: ZA=for or PR=against
1793–1865	Andreas von Baumgartner	1857 AM, 1860 WB, 1864 AM	PR
1804–1877	Karel Robida	1860 K, 1864 ZMF, 1865 ZM<<<<f	PR
1809–1863	Ferdinand Redtenbacher	1857, 1861 K	PR
1816–	Joseph Polák	1867 Iz	?
1821–1895	Josef Loschmidt	1865, 1866, 1867, 1869, 1870 WB	ZA
1826–1883	Gustav J. Schmidt	1860 WB, 1861 DP, 1861 K+Iz, 1865 WB, 1871 DP	PR
1827–1888	Franz J. Pisko	1875 Iz	ZA
1825–1912	Karel Puschl	1869 K, 1861, 1862 Iz, 1862, 1863, 1870 (2), 1874 (3), 1875 (4) WB	PR
1830–1903	Simon Šubic	1862 K+WB, 1863 WB, 1864 Iz, 1872 PA (2), 1872, 1873, 1874 R	PR
1833–	August Schwarzer	1859 Iz	ZA
1833–1905	Martin Sekulić	1874 R	PR
1835–1883	Jožef Stefan	1858 WB, 1863 WB (2), 1863 PA, 1871 WB, 1872 WB	ZA
1836–1927	Gustav Tschermak	1860, 1861, 1862 WB, 1863 K	PR
1837–	Heinrich Schramm	1872 K, 1873 Iz	PR
1837–1915	Aloiz Handl	1867, 1872 (2), 1874, 1875 WB	PR
1838–1924	Szily, Kálmán von Nagy Szigeth	1872, 1873, 1875 PA	ZA
1838–1916	Ernst Mach	1862 WB, 1872 K	ZA+PR
1838–1913	Ferdinand Lippich	1870 PA	ZA
1838–1921	Victor E. von Lang	1871 WB, 1872 WB	ZA
1839–1920	Leopold von Pfaundler	1869 WB, 1871 WB	ZA
1840–1925	Emil Herrmann	1871 WB, 1875 In	ZA
1842–	Karl Klekler	1869 Iz	ZA
1843–	Julius Eibel	1868 ZMF	ZA
1844–1906	Boltzmann	1866, 1867, 1868 (2), 1871 (3) WB, 1871 PM, 1871 PA, 1872 (2) WB, 1875 (2) WB	ZA
1844–1908	Antun Laska	1874 Iz	PR
1845–1920	Ivan Benigar	1870 WB	ZA
1845–1918	Julius Puluž	1874, 1875 WB	ZA
1846–	Andrej Wretschko (Vrečko)	1870 WB	ZA
1846–1916	Luka Lavtar	1873 LM	PR
	Josef Plank	1875VBz	ZA
1852–1915	Oskar Simony	1873, 1874, 1875 ZMF	PR
185?–	Wenzel Grünert	1873 Iz	ZA
	Johann Hammerschmied	1872 K	PR

Table 18-4: Discussions on heat, the theory of molecules and vacuum in the high school reports of the Habsburg monarchy between 1850 and 1875. Those that relate (also) to the kinetic theory of gases are marked with KT, and in addition to the place there is also a type of school: Lower Real school (NR), Higher Real school (VR) or Gymnasium (Grammar School, G).

Year	Writer	Topics	Place and school	Notes
1855	Franjo Mathon (* 1828)	Heat	Rijeka, G.	KT
1855	Wenzel Svoboda	Atomism	Bratislava, Catholic G.	not KT?
1859	August Schwartzner	Heat	Prague, German VR	KT
1860	Chrysostomus Amon	philosophy of atoms	Wiener Neustadt, VR	not KT
1861, 1862	Karl Puschl	force among molecules	Melk, monastic G.	KT
1863	Ignatz Weiner (* 1831)	Heat	Brno, NR	not KT
1864	Simon Šubic	Temperature	Vienna Rossau, NR	KT
1867	Joseph Polák (* 1816)	Heat, meteorology	Kecskemét, G.	not KT
1869	Karl Klekler (* 1842)	Thermodynamics	Pančevo, VR	KT
1873	Ivan Benigar (* 1845; † 1920)	Heat Transfer	Vinkovci, G.	not KT
1873	Wenzel Grünert	Heat	Brno, German G.	KT
1873	Heinrich Schramm	attractive force	Wiener-Neustadt, VR	KT
1873	Dragutin Kössler (* 1842)	Heat Transfer	Rijeka, G.	not KT
1874	Antun Laska (* 1847; † 1908)	Molecular theory	Požega, VG	KT
1875	Franz Joseph Pisko (* 1827; † 1888)	Heat	Vienna, Sechshaus VR	KT

included secondary school reports from the Hungarian half of the monarchy if researchers native in the Austrian half of monarchy published there including Prlekija native Josip Križan in the Varaždin grammar school, Klekler on the Higher Real school in Pančevo,²³⁶⁴ Mathon and Puluž in Rijeka, Wenzel Svoboda in Bratislava, and Polák at the Catholic Gymnasium of the Piarists in the city of Kecskemét, southeast of Budapest. Austrian research includes posts directly subordinate to Vienna in the Military Krajina (Pančevo, Varaždin, Rakovac), but not the published works of Hungarian researchers, such as the findings of Kálmán Szily von Nagy-Sziget (1838; † 1924) in Pogg. Ann. and Phil. Mag. In addition, we did not include Andreas baron Ettingshausen (* 1796; † 1878), physiologist Carl Friedrich Wilhelm Luddwig and Joseph Wilhelm Grailich (1829; †

1859). All three of them were important organizers of the research of kinetic theory in Vienna, and especially excelled as Stefan's teachers; among their publications there are no major research on kinetic theory, although they were very close to them.²³⁶⁵

Between 1856 and 1875, thirty-two Habsburgian (Austrian) researchers published 48 works in support of kinetic theory and the same amount against it. However, three more researchers have accepted the novelty nicknamed kinetic theory. Of course, in the following years of Tesla's studies in Graz and Prague, Stefan's co-workers dominated. Apart from the Mach's chair in Prague, they occupied all the most important positions in the monarchy. Between 1850 and 1875, nine Austrian secondary schoolteachers supported kinetic theory, with only four against it. The secondary school teachers thus predominantly supported the novelty, since they were mostly raised in that kinetic spirit

²³⁶⁴

babel.hathitrust.org/cgi/pt?id=mdp.39015062383578;seq=878;view=1up;num=874,
babel.hathitrust.org/cgi/pt?id=mdp.39015062383560;seq=887;view=1up;num=881, Retrieved 2. 2. 2013

²³⁶⁵ Ludwig, 1856; Ettingshausen, 1857.

during their Viennese schooling with Andreas Ettingshausen and his successor, Jožef Stefan.

It cannot be argued that support for kinetic theory would depend on the distance between Vienna and the place in which the individual writer investigated. In the era of Tesla's schooling in Sekulić's class in Rakovac, opposition to kinetic theory and Boltzmann's statistical mechanics was still possible. Soon afterwards, it was no longer fashionable except for E. Mach's networks; the new theory became part of unambiguous basic lessons at universities, and attention of Tesla and other upcoming researchers re-orientated to vacuum technology as the foundation of modern electrical engineering two centuries after its humble beginnings. During Tesla's studies at the secondary school in Rakovac, papers about electromagnetism already prevalent among the discussions in high school reports in Germany and the Habsburg Monarchy.²³⁶⁶

Tesla passed the exam in statistics (political arithmetic) at Graz in Rogner's class and, of course, he knew Boltzmann's statistical theory of entropy. Like Boltzmann or Einstein, due to classical teaching at Sekulić's class, Tesla could never really agree with the statistical notion of invisible movements in a vacuum, as presented by quantum mechanics after Tesla's meeting with Abraham in Tesla's 40th year. Šubic and Sekulić²³⁶⁷ preferred to replace Redtenbacher's *Dynamides* with Clausius's kinetic conception of an atom, where ether was unimportant.

Redtenbacher's *Dynamide* played a similar role in central Europe as did Bošković's altering force in the British islands where it was fertilized by Maxwell's repulsive force decreasing with the fifth exponent of distance.

On 27 June 1871 Šubic gave up Redtenbacher's theory in favor of Clausius's kinetic conception of heat, which did not offer any special model of atom.²³⁶⁸ Šubic's friend Sekulić endorsed a similar opinion,²³⁶⁹ but Sekulić (July 9, 1873) contradicted Šubic by sharp critique of the very concept of ether half of a month before Tesla's Matura (24 July

1873) while referring to Šubic's earlier text from 1862.²³⁷⁰ Šubic did not explain his opinion on Redtenbacher's *Dynamides*, but the existence of the ether was advocated by Šubic in his textbooks and even in some scientific works.²³⁷¹ Contrary to dynamics, Šubic's acceptance of atomistic theory is also witnessed by his description of the capillary force with molecular forces that transform the droplet into the oval shape of the molecule²³⁷² and are indeed the forces of cohesion.²³⁷³

18.5.6 Ether

In 1874, the sharp critic of the use of the ether in vacuum physics was Sekulić, but above all, of course, Ernst Mach disliked such things which nobody could touch. Jožef Stefan's beliefs in physics differed deeply from the assumptions of Simon Šubic, Sekulić or Tesla. In February 1883, Tesla was in Strasbourg. The opening of the 3rd International Electrical Exhibition in Vienna under Stefan's technical guidance was on August 11, 1883. Tesla could not miss that. But Tesla was just a telephone expert. So, Tesla may not personally know two decades older Stefan unless he met Stefan a little before Stefan's death when Tesla visited Vienna in April 1892²³⁷⁴ to attend his mother's deathbed during her last hours. Stefan and most of Andreas Ettingshausen's other pupils including Boltzmann, were the fans of ether consisting of constantly moving molecules resembling the (larger) molecules of ordinary matter.

Simon Šubic has rejected this model of ether already during his service in Pest.²³⁷⁵ In his early discussions Šubic opposed the physical theories of matter without weight, among which the ether dominated.²³⁷⁶ In the textbook for higher grades, Šubic used the ether hypothesis only for the spreading of light in the first edition of the foreword dated in "the summer of 1860".²³⁷⁷ In later editions of his textbook²³⁷⁸ and in his papers,

²³⁷⁰ Sekulić, 1874, 111.

²³⁷¹ Šubic, Rad 1874, 1–2.

²³⁷² Šubic, 1874, 208–215.

²³⁷³ Šubic, 1874, 27.

²³⁷⁴ Mrkić, 2004, 45.

²³⁷⁵ Sekulić, 1874, 111.

²³⁷⁶ Šubic, 1862, 1; Šubic, Z. öst. Gym. 1862, 320–321; Šubic, Z. öst. Gym. 1864, 528.

²³⁷⁷ Šubic, Lehrbuch 1861, 345.

²³⁷⁸ Šubic at his second edition in 1867 on p. 17, in third edition in the year 1874 on p. 26.

²³⁶⁶ Hübl, 1869, 208–210.

²³⁶⁷ Laska, 1877, 6–7; Šubic, 1871, 20; Sekulić, 1874, 110;

Šešić, 1996, 67–68.

²³⁶⁸ Šubic, 1872, 20.

²³⁶⁹ Sekulić, 1874, 110; Šešić, 1996, 65.

Šubic accepted the hypothesis of the ether, although ether did not play any very important role in his theoretical models. Šubic obviously changed his opinion on the ether between 1864-1867. Karl Robida supported Šubic's initial doubts about the ether, when he commented on the Šubic's book of 1862. Robida said that he was looking forward to "rejection" (Verwerfung) of the matter of various ethers²³⁷⁹ that Šubic would publish in future. None of them even went as far as Sekulić, who even called ether a "fictitious means... by which naturalists jump out of the frying pan into the fire... an imagination tool of avoiding problems."²³⁸⁰ At least partly, Sekulić referred to Šubic himself.²³⁸¹

Šubic was reluctant to deny the existence of an electrical immobile media-substance. Šubic otherwise resolutely rejected the imponderable matter in his optics and thermodynamics.²³⁸² However, this does not necessarily mean that Šubic was emancipated from ether as the first 'in Šubic's papers' as Tesla's teacher Sekulić claimed.²³⁸³

Sekulić did not see a significant difference between the ether that emerged from Fresnel's wave theory (of light) compared to the other weightless substances from the 18th century and the early decades of the 19th century, such as caloric. Šubic initially rejected the description of the ether as a substance without weight.²³⁸⁴ It seemed to him that we were returning with such an ether to already abandoned but secretly surviving forms of theory. However, Šubic later acknowledged the existence of a weightless ether for the transfer of a light wave²³⁸⁵ as well as for the transfer of a thermal wave²³⁸⁶ in a vacuum. With this he denied Sekulić's claims.²³⁸⁷ Between the submission of Sekulić's papers on July 9, 1873 and the submission of Šubic's paper on 26 March 1874 for the press in the same newspaper Rad only half of a year passed. The contradictory statements of the two authors testify that in this time, shortly after Tesla's graduation, they were no longer in close

personal or written scientific contacts, although Sekulić named his former colleague from Pest Šubic as a friend.²³⁸⁸

Sekulić relied to the assumption²³⁸⁹ that Šubic (1862) was not favorable to the ether, especially not in the theory of heat; there may have been the least need for ether in the theory of heat because heat was not primarily related to radiation. This duality of the treatment of the same phenomenon in various circumstances later enabled Planck (1900) to partially quantify the electromagnetic field, which, before Einstein's intervention in 1905, focused only the radiation, not the absorption. Such double criteria were the roots of modern dualism of quantum mechanics, which links the properties of particles and waves in matter.

The development of the concepts of ether was and still is extremely complex. In his papers in 1874 Sekulić tried to ignore ether completely. The main researchers of Boltzmann's ideas did not come to serious doubts about the necessity of ether before Einstein. Perhaps the doubt of atomism and ether among scholars waited for the turn of the century. Because of his illness Boltzmann has almost ignored much of his contemporary development of physics in the last decade of his life. He did not mention Planck (1900) and Einstein (1905) in his Viennese lectures, and thus closed himself behind the fascicles of classical physics, which he himself most helped to change!

Tesla was close to that nice Boltzmann's opinion, because Tesla did not accept Sekulić's judgements in 1891 when Tesla claimed that the ether-related thing can be called electricity, although they are not the same.

Tesla had electric charge for the state of tension of the ether, much like the Liverpool radio pioneer Oliver Lodge. One year after Tesla on 14 August 1894 during his Oxford lecture, Lodge transmitted radio waves as evidence of their communication possibilities. So, Tesla opposed Einstein's deletion of the ether from the theory of relativity. Tesla did not agree that ether was just a superfluous unnecessary medium.²³⁹⁰

²³⁷⁹ Robida, 1863, 463.

²³⁸⁰ Sekulić, 1874, 110.

²³⁸¹ Šubic's report in Wien. Ber. had a wrong year 1861 instead of 1862 (Sekulić, 1874, 111).

²³⁸² Šubic, *Zeitschrift für die österrei.chischen Gymnasien* (*Zeit. gymn.*) 1862 in Sekulić's narration, 321.

²³⁸³ Sekulić, 1874, 111; Muljević, 1973, 334.

²³⁸⁴ imponderabel (Šubic, 1862, 230).

²³⁸⁵ Šubic, Lehrbuch 1874, 26, 460, 524, 540, 541.

²³⁸⁶ Šubic, Rad 1874, 1–2.

²³⁸⁷ Sekulić, 1874, 111.

²³⁸⁸ Sekulić, 1874, 111.

²³⁸⁹ Sekulić, 1874 111.

²³⁹⁰ Dadić, 1982, 2: 310–311.

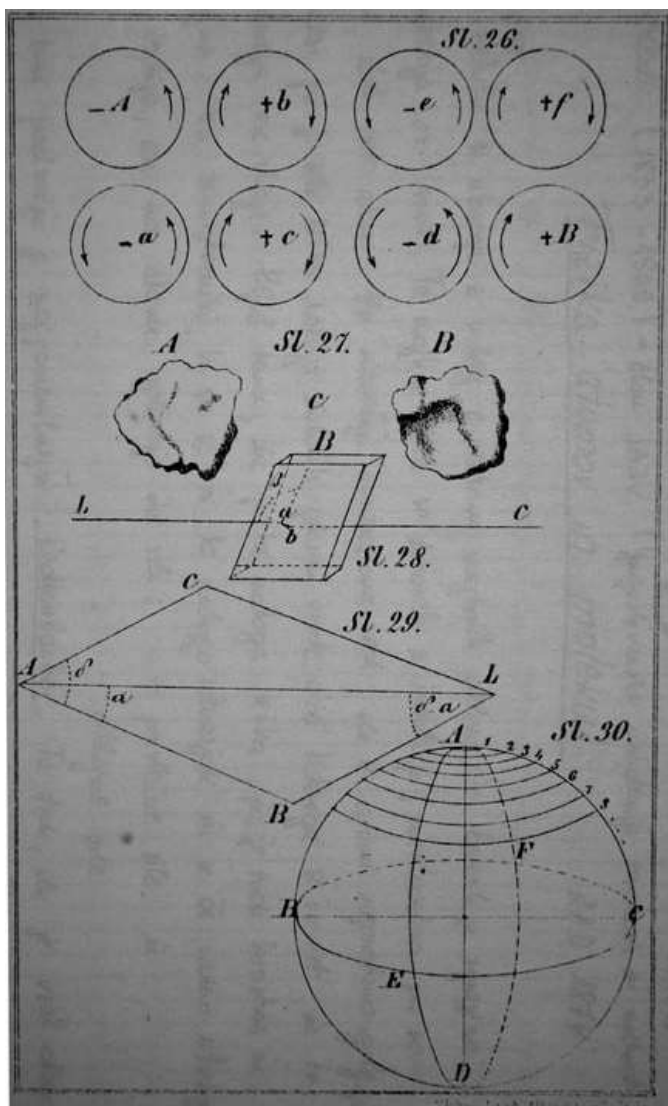

Figure 18-39: The seventh group of images with Sekulić's magnetic sketches (Sekulić, 1874)

Tesla and Kelvin knew, respected and cited each other as they were both fans of Bošković.

Therefore, Tesla's vision of the dynamic ether was related to Kelvin's ether in motion which then could behave as a solid transmitting the transversal electromagnetic waves while the same ether behaves like highly exhausted fluid gas resembling vacuum needed for the frictionless movements of cosmic bodies. Tesla's molecules rotated their ether like the Dynamides of director of the Polytechnic in Karlsruhe the initiator of scientific mechanical engineering Ferdinand Redtenbacher (* 1809 Steyr in Upper Austria; † 1863 Karlsruhe). Ferdinand Redtenbacher published the theory of smallest ultimate material elementary nuclei with envelopes from the ether in 1852 and 1857 in the

times of Tesla's birth.²³⁹¹ Redtenbacher's theory was based on Regnault's Parisian experiments and on the model of vibrations in solids. Ferdinand Redtenbacher gained a great initial support in Habsburg monarchy thanks to the key position of Ferdinand Redtenbacher's younger second cousin the chemist Josef Redtenbacher (1810 Kirchdorf by Krems-1870) in the Viennese academy and Josef's brother the director of Viennese natural history museum correspondent member of the Viennese Academy Ludwig Redtenbacher (1814 Kirchdorf-1876 Vienna). Josef Redtenbacher used to be F. Mohs and Liebig's student.

Tesla proposed few great thought experiments about gravity, just like Einstein. Tesla stated in June 1900: "To make the disk rotate by the force of gravity we have only to invent a screen against this force. By such a screen we could prevent this force from acting on one half of the disk, and the rotation of the latter would follow. At least, we cannot deny such a possibility until we know exactly the nature of the force of gravity." Tesla indeed repeated the old model of Newton's friend Nicolas Fatio de Duillier (1690) and Bošković's friend Georges-Louis Le Sage (1748). Even Einstein's relativity did not give the final answers to Tesla's puzzle five years later, nor in continuing Einstein's efforts, until both guys passed away.

Tesla's dynamic gravity replaced Einstein's curved space with the equivalent forces. Non-Euclidian geometry of Einstein's general relativity was beyond Tesla's mathematical education, while the classic concepts of forces were clearly Tesla's favourites. To make himself more popular and to compete with Einstein's laws, thermodynamic laws or quantum mechanical laws, Tesla declared his own law without any energy in matter except the energy attracted from the outer media.²³⁹²

18.5.7 Northern Light and Fluorescence

The examination of spark and lightning enabled Sekulić's studies of fluorescence in Tesla's student years. Stokes assumed that the force between the molecules is in a simple relationship with their distances from the equilibrium position. It depends on the composition of the ether and the distance

²³⁹¹ Tesla 1956 (1891) L-15-17; Redtenbacher, *Principien der Mechanik*, Mannheim 1852; *Das Dynamiden-System*, Mannheim 1857.

²³⁹² Tesla 1937; Pandur 2018.

between the molecules of the substance, while the vibration amplitude is infinitely small in comparison with the size of the molecules. The period of oscillation of the molecules is different from period of oscillation of the particles of the ether, and the frequency of fluorescence is reduced by decreasing the amplitude.²³⁹³ In 1853, Anders Jonas Ångström did similar experiments independently of Stokes, but he came to the opposite conclusion. According to him, the atoms of the ether should even oscillate quicker and fluorescent light would therefore have a higher frequency than absorbed.²³⁹⁴ Josip Torbar (* 1824; † 1900), professor of physics and natural history at a Higher Real school in Zagreb, supported Olmsted's theory of the cosmic genesis of the northern light in his paper *North Dawn (Sjeverna zora)*. Torbar rejected the theory of August de la Rive about electricity as the causative agent of the northern light (Aurora Borealis). The following year Tesla's professor Sekulić published a discussion on the electric nature of the northern light: *Polar Dawn as the effect of the Earth's Electricity (Polarna zora kao učinak zemaljske munjine)*.²³⁹⁵ Sekulić opposed Torbar, and he even compiled his own machine for the simulation of northern light (Aurora Borealis) in laboratory and the spectral analysis of its light,²³⁹⁶ which was certainly used by Sekulić's informal assistant Tesla. Tesla later repeatedly magnified that idea with his lightning sparks in Colorado Springs. Sekulić relied on very early assumptions about the electrical nature of weather phenomena, including the report of the red rain of Edmund Halley from 1731 and the ideas of Benjamin Franklin.²³⁹⁷ Sekulić made immediate use of Kirchhoff's books which he bought with the help of the librarian in Rakovac Kreminger in 1872/73 after the Aurora Borealis was seen in his areas on October 14th and 15th, 1870. Such events are extremely rare on Mid-European geographic longitudes. Therefore, everybody took his or her opportunity to examine and explain them because many curious funny Central-European folks preferred to see Aurora Borealis as a kind of miracle. Sekulić backed the Geneva professor Auguste Arthur de la Rive's (1801-1873) theory, which soon lost its popularity.

²³⁹³ Sekulić, 1871, 80; Šešić, 1996, 58.

²³⁹⁴ Sekulić, 1871, 80; Kayser, 1908, 866.

²³⁹⁵ Sekulić, 1872, Rad; Sekulić, 1877/78); Sekulić, Rad 1872.

²³⁹⁶ Dadić, 1982, 2: 257–258; Šešić, 1996, 62.

²³⁹⁷ Šešić, 1996, 61, 76.

De la Rive tried to prove with spectral analysis the similarity of Aurora Borealis, lightning, and ordinary discharge which stimulated Sekulić to do the same in 1872. Sekulić observed the ultraviolet part of Solar spectrum after he studied Tyndall's book *Heat* which Kreminger also bought in Rakovac in 1871/72.²³⁹⁸ Sekulić's Aurora Borealis research with Tesla's as his informal assistant was admired by the reader of Sekulić's paper William Garrow Lettsom (1805-14/12/1887).²³⁹⁹ The expert of astrophysics, crystallography, electrical engineering, geology and spectroscopy William Garrow Lettsom took a personal interest in Sekulić's exploration of the northern light (Aurora Borealis) and (ultra)violet light of the Sun. Lettsom became famous in 1858 when he joined the Manchester magnate Robert Philips Greg and published his well-documented high-profile history of English geology. Lettsom was a diplomat in Europe and South America until 1869; then he retired. He was a member of the Royal Astronomical Society in London since 1849. During Tesla's studies at Sekulić's class in the mid-1870s, Lettsom mainly studied minerals with their optical properties and a comet visible in 1882.

Lettsom's intervention was described as the discovery of ultraviolet rays in the Solar spectrum by JAZU secretary Josip Torbar at the celebratory JAZU session.²⁴⁰⁰ On 15 August 1873, the most important German physical journal supported Sekulić's theory of interference which was translated from the Croatian language.²⁴⁰¹ On 15/8/1873 the translation of Sekulić's theory of interference²⁴⁰² pleased Kirchhoff's student Friedrich Wilhelm Feussner (* 1843; † 1928) who came across the similar discovery previously but preferred to support Sekulić without disputing his priority.²⁴⁰³ Feussner ensured that he already noticed Sekulić's interference; but he was not running for a priority, but mostly supplemented Sekulić's observations. Feussner advocated the wave-theory of light. Feussner later taught kinetic theory of gases in Marburg University from 1887

²³⁹⁸ Torbar, 1873, 252; Šešić, 1996, 64; Muljević, 1973, 333

²³⁹⁹ Erroneously written family name as Lettsom (Dadić, *Povijest* 2, 258).

²⁴⁰⁰ Torbar 1873, 252; Šešić, 1996, 64; Muljević, 1973, 333

²⁴⁰¹ Sekulić, 1873, 126–128.

²⁴⁰² Martin Sekulić, Eine merkwürdige

Interferenzerscheinung, *Poggendorff Annalen der Physik*, 5, 225 (1873): 126-128.

²⁴⁰³ Feussner, 1873, 561-564.

until 1901/1902.²⁴⁰⁴ Feussner tried to upgrade Sekulić's theory even with the citations of Bošković's student Karl Benvenuti (1716-1789).²⁴⁰⁵ The international echoes of Sekulić's research soon gained attention of his superiors in Zagreb, as well as the admiration of Tesla and his classmates.



Figure 18-40: Portrait of Tesla High School Professor Martin Sekulić with His Own Signature

Robida opposed the entropy law of R. Clausius, while Šubic devoted his most relevant publications to criticism of Boltzmann's H-theorem in 1872 against the framework of emerging statistical mechanics. Next to them, Sekulić entered the shabby soil of the theory with the claim that the electromotive force or the energy of the Voltaic battery is proportional to the produced heat. Sekulić tried to prove that the energy of the chemical reaction is proportional to the produced heat, perhaps as the example of the Energy Conservation Law adopted in Sekulić's boyish years by R. Mayer and Helmholtz. Sekulić thus supported the theory of his friend Peter Jørgen Julius Thomsen (1826-1909) from the University of Copenhagen published in 1854 and assisted a decade later with the theory of Marcellin Berthelot (1827-1907). Sekulić's conclusion was in accordance with the opinion of Sekulić's friend

²⁴⁰⁴ Feussner, 1873, 561.

²⁴⁰⁵ Feussner, 1877, 323.

Thomsen. However, the Energy Conservation Law was already out of the mainstream focus of those days which was predominantly directed to the 2nd law of thermodynamics in Sekulić's era. Thus, Sekulić's assumptions did not coincide with the results of the measurements of the former director of the Munich Polytechnic Wilhelm von Beetz (1822-1886). Sekulić also opposed J. Stefan's student the director of former Loschmid's Viennese Physics-Chemical Institute Franz Serafin Exner (1849-1929),²⁴⁰⁶ and Sekulić even contradicted Hermann Helmholtz's ideas developed in Berlin in 1882. Helmholtz explained that affinity is not related to the heat of the chemical reaction, but with the maximal possible work of the reversible reaction.

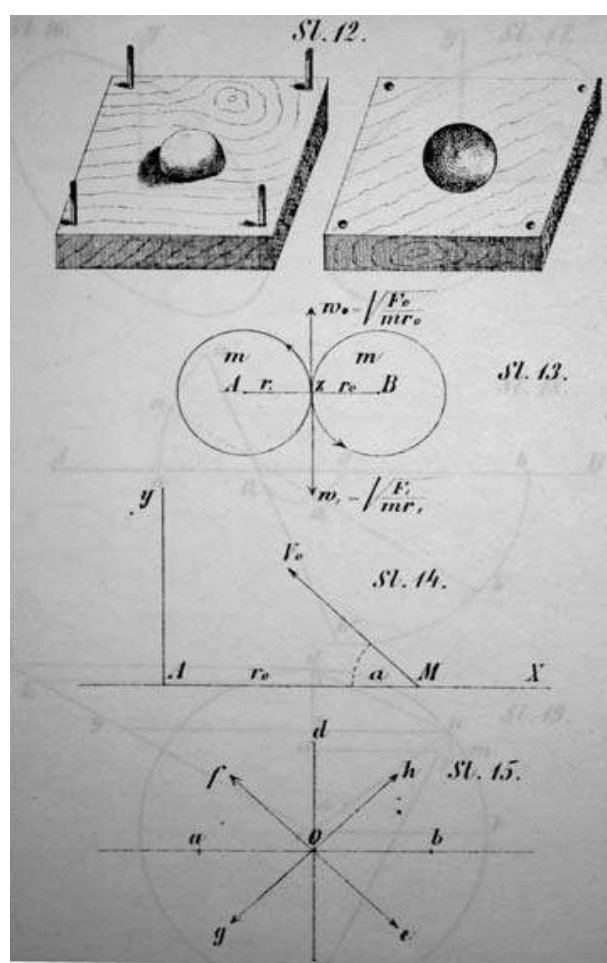

Figure 18-41: Third Group of Sekulić Illustrations of Molecules (Sekulić, 1874).

Sekulić's claim was the generalization of Thomsen-Berthelot's principle, which Thomsen set in 1854, and Marcellin Bertelot supplemented in 1864 with thermal theory of affinity. Such a discovery was too great achievement for secondary school

²⁴⁰⁶ Sekulić, 1881, 171-172; Šešić, 1996, 72.

professor Sekulić; although he published his ideas in Zagreb, he presented just his summaries in Vienna and Leipzig.²⁴⁰⁷ Immediately after Sekulić's announcement in Zagreb, Hermann Helmholtz in Berlin in 1882 used the entropy law to prove that affinity was not given by the heat evolved in a chemical reaction but rather by the maximum work produced when the reaction was carried out reversibly. However, while kinetic and mechanical energy can be converted into heat in every case, only in restricted cases can heat be converted into kinetic and mechanical energy. Hence, the equations describing chemical processes involving heat could not always be reversed, therefore the affinity does not determine the heat of the chemical reaction, but the maximum work in a reversibly derived reaction. Of course, the disappointed defeated Sekulić abandoned his scientific pursuits and became so much louder in politics. Helmholtz was certainly not his match.

That was the final blow to the just retired Sekulić whose paper Helmholtz's backer Jožef Stefan read in front of Viennese academy on June 21, 1878. As a secretary, Stefan prevented the publication of Sekulić's ideas in Viennese academical networks as did Wiedemann in *Annalen der Physik* in Leipzig. Wiedemann just became the new editor of *Annalen der Physik* as a replacement of the deceased Poggendorff's (1796-1877). In his paper, Sekulić cleverly stated that Poggendorff supported similar theory, but Poggendorff died too soon to use those novelties. Tesla and his classmates initially certainly shared Sekulić's views as Sekulić's students because Sekulić's international fame was very challenging in Rakovac. In the same way, Stefan shared the wave theory approach of his high school teacher Robida but abandoned it soon after Stefan became the Viennese student. When Sekulić published his total critique of reality of ether in article printed in Zagreb Academic journal *Rad* in 1874, Tesla was certainly immediately informed during his illness in Gospić. It was probably unclear to local Croatian non-experts that Sekulić was challenging the mainstream physics (and chemistry), but it became obvious on June 21, 1878, when the uncrowned chief of Habsburg physics Jožef Stefan refused to back Sekulić. It is hard to guess which side did Löffler pick up in that quarrel because he published only on mathematics and gymnastics. In that time Tesla had a bad luck with his lenders and

took a shelter in Maribor, but such Stefan-Sekulić's scandal was loud enough to catch his ears because even later Tesla was interested in Sekulić's whereabouts in Tesla's letters to Tesla's domestic friend Mojo Medić. In that Tesla's Maribor times it was probably a high time for Tesla to choose sides and he eventually backed the ether and Sekulić's opponents. On 20th May 1891 (sic!) Tesla stated for *American Society of Electrical Engineers* in New York Columbia University where Mihajlo Pupin lectured that the ether is connected to matter and may be called electricity although both are not completely identical. Tesla's electrical charges were a state of strength of ether like in the contemporary visions of Oliver Joseph Lodge (1851-1940). Tesla even stated that „light can be nothing else than a sound wave in the ether; and the shorter the waves the more penetrative they will be.” The wave of sound is certainly a longitudinal wave. Indeed, Tesla “forgot” to mention the fact of transversal waves of light in the times when even Helmholtz believed in the longitudinal component of electromagnetic waves.

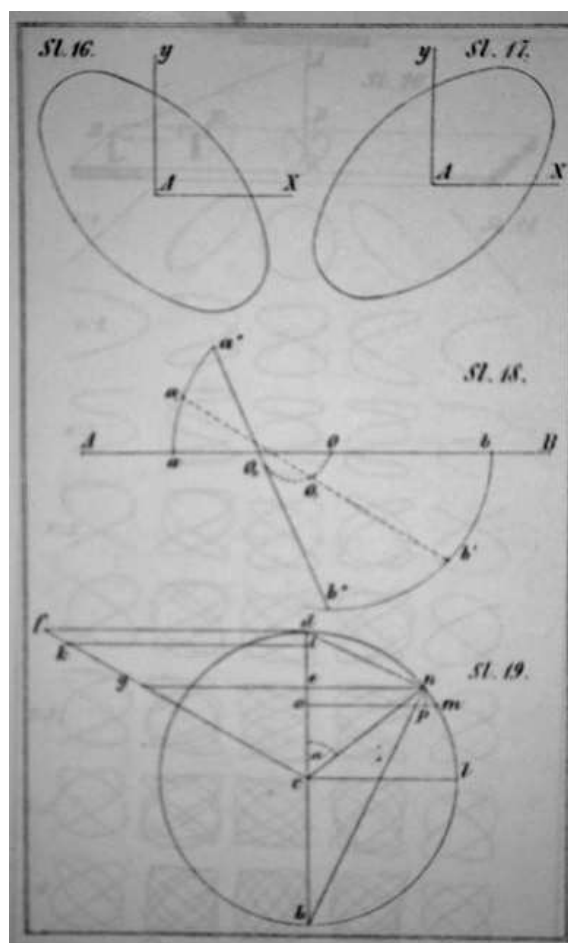

Figure 18-42: The fourth group of Sekulić illustrations of molecules (Sekulić, 1874)

²⁴⁰⁷ Sekulić, 1881, 190; Sekulić, 1878 *Anzeiger*, 129.

During that time, Tesla was already quite anchored in electrical engineering, and Sekulić again met Tesla a decade later in Zagreb. Sekulić was certainly extremely proud of Tesla's class, as half of Tesla's classmates studied chemistry-physics in Vienna or Graz, but only Tesla did not finish his studies. Tesla's ideas required the American business moneymaking confirmations under Niagara Falls before they were accepted in his native domestic European environment.

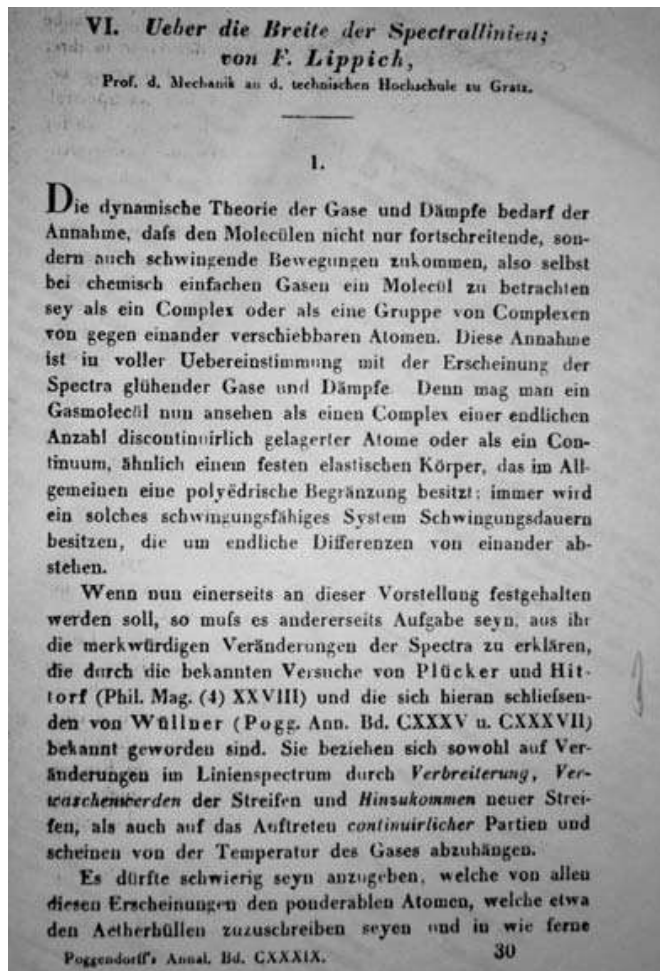

Figure 18-43: The beginning of Lippich's Graz discussion of cathode ray tubes in a leading physics journal with an explanation of the results of Plücker and Hittorf experiments in Bonn (Lippich, 1870).

18.5.8 Tesla in Graz

Sekulić and other professors in Rakovac were so enthusiastic about Tesla that Tesla did not want to continue family traditions in a military or priestly skirt, but he also wanted to become a teacher himself. In the autumn of 1875, he enrolled in the pedagogical or chemistry-technological field of the Polytechnic (Technische Hochschule am Joanneum

zu Graz). In the previous year Graz Polytechnic its curricula and students' opportunities into four faculties: building, mechanical mechanics, chemistry, technology and forestry.

Ferdinand Lippich²⁴⁰⁸ studied in Prague as a guest of his aunt Tereza. He was the professor of the graphical statics, theoretical and applied mechanics in Graz Polytechnic between the years 1865-1874. Just before Tesla's matriculation he became the ordinary professor of mathematical physics at the University of Prague. In Graz he was the rector from 1 October 1870 to 30 August 1871, and the Dean of the Mechanical School (Engineering Faculty) from 1 October 1869 to 30 September 1870. Initially, like his friend Ernst Mach during his Viennese youth, he defended the winning branch of the kinetic theory, referring to experiments with cathode ray tubes of Julius Plücker and his student Johann Wilhelm Hittorf. By his precise vacuum experiments, Lippich determined the influence of the motion of gas molecules on the width of the spectral lines.



Figure 18-44: Vacuum researcher of the Slovenian genus Ferdinand Lippich, the son of a doctor from Ljubljana and the grandsons of Upper Carniolan folks (Gorenjci) from Kropa. There flows the stream of Kroparica to the mouth of the Lipnica stream, which may have lent the name to the Lipič (Lippich) family of Carniola.

²⁴⁰⁸

http://www.landesmuseum.at/pdf_frei_remote/Lotos_62_001_3-0018.pdf consulted on February 2, 2013.

With Clausius-König's kinetic theory Lippich researched the spectra of oxygen in Geissler's tube at the same time when Tesla's professor Sekulić published similar spectral analysis. Lippich continued with that topics in Prague, criticized the electrodynamics of Franz Neumann (1877), and experiment of Leipzig professor of astrophysics Johann Karl Friedrich Zöllner performed in 1874.²⁴⁰⁹ Zöllner visited Crookes immediately after discovering a radiometer with more spiritual inclinations, just like later Tesla. Lippich retired in 1910 and Albert Einstein took over Lippich's Prague chair. The thrifty Einstein and his bride from the Military Krajina did not want to buy new mattresses, even though the old ones full of funny insects were most probably fatal for their marriage.



Figure 18-45: Tesla's Graz Professor of Mathematics, Moritz Allé (* 1837; † 1913)

Lippich's obituary was accomplished by the main Prague supporter of Einstein's theory of relativity Anton Lampe (* 1868, Pest; † 1938)²⁴¹⁰ who got his PhD with Boltzmann in 1893. The research of kinetics theory and atmospheric electricity of

Ferdinand Lippich and his nephew Paul Czermak became very fruitful in Tesla's hands.

Tesla studied with all his forces in his first year of the Polytechnic in Graz, and to a considerable extent also as a sophomore. He did not pass any exams during his third year until January 1878. His principal professors at the Polytechnic School were Jakob Pöschl for theoretical and experimental physics, and Moritz Allé (* 1837, Brno; † 1913) for higher mathematics.²⁴¹¹ Johann Rogner taught the differential and integral calculus, mathematics I, about the volume of solids of revolution, and applied arithmetic. On 23 January 1937, in his thanking for the honorary doctorate of the Technical and Montanist High School in Graz, Tesla in his telegram remembered the rector Allé with gratefulness, as well as the friendly lessons of Rogner and even²⁴¹² Pöschl maybe with his fingers crossed.

On the first year of his Graz Machine engineering Studies²⁴¹³ in 1875/76, Tesla also excelled in Maly's exam of organic and inorganic chemistry. Tesla passed his exam in Graber's class in zoology. Tesla was also successful on the exam in the class of S. Šubic's enemy full professor of botanic appointed in 1869 Hubert Leitgib of general botanic with demonstrations, and in Josef Bart's class of popular mechanical engineering. Tesla also excelled with his knowledge of French language at Plisnier's class. Of course, this was twice too much for an average student in Graz. Thus, the chemist Heinrich Schwarz (Karl Leonhard, * 1824; † 1890) was worried. Heinrich Schwarz was the dean of the chemistry-technical faculty from October 1, 1874 to 30, September 9, 1876, and next served as the rector from October 1, 1876 to 30 September 1877. Heinrich Schwarz wrote to Tesla's father to describe Nikola as a star in experimental, theoretical and linguistic terms.²⁴¹⁴ At the same time, Schwarz warned Tesla's father against Tesla's excessive efforts which could ruin Tesla's health. That's why the father Milutin received Nikola with coldness when Nikola arrived in Gospić for holidays. The humiliated Nikola understood his father's behavior only few years later after his father passed away

²⁴⁰⁹ Lippich, 1880.

²⁴¹⁰

http://www.landesmuseum.at/pdf_frei_remote/Lotos_62_001_3-0018.pdf consulted on February 2, 2013.

²⁴¹¹ Mrkić, 2004, 22; Jovanović, 2001, 48–49; Kulišić, 1936, 11; Wohinz, 2007, 172–175; Cverava, 2006, 28.

²⁴¹² Wohinz, 2007, 181–182; Cverava, 2006, 32.

²⁴¹³ Marinčić, 2006, 35.

²⁴¹⁴ Cverava, 2006, 30.

The most important Tesla's Graz connection with Slovenian science was **Ferdinand Lippich** (Lipič, * 1838 Padua; † 1913), the son of Ljubljana physician Fran Viljem Lipič (Lippich, * June 13, 1799 Spišská Nová Ves (Igló) west of Košice in Slovakia; † December 12, 1845 Vienna). It's a pity that Lippich left Graz for Prague University just before Tesla matriculated in Graz, but they certainly met later during Tesla's studies in the University of Prague. Ferdinand's grandfather physician Jožef (* February 5, 1761 Ljubljana) descended from Venetian family of Boka Kotorska which settled in Kropa in Upper Carniola. Ferdinand's father began his studies of medicine in his 18th year in Pest which was a part of later Budapest. He was promoted in Vienna on May 26, 1823.²⁴¹⁵ In the same year he became the second physician of the Ljubljana city, in 1832 he was the provisory district physician, and next year he became the deputy head of hospital. He invited to Ljubljana his sister Tereza (* 1800). In Venice Tereza married the psychiatrist in Graz and later in Prague dr. Franc Koestl (Köstel, * 1811 Cerklje in Upper Carniola; † 1882 Graz). She became a talented student of painter Matej Langus. Fran Viljem Lipič (Lippich) had problems with Ljubljana monks who were homeopaths as opposed to the authorities and therefore Lipič accepted the chair of internal medicine in Padua in 1834. In 1841 he left for Viennese University as the predecessor of Jožef Škoda (* 1805; † 1881), the mentor of Jožef Stefan. In 1826 Fran Viljem married the Styrian orphan Alojzija Kajetana Kahr (* 1805 Ilz). They had a dozen children but just five of them grew up, among them Wilhelmine (* 1831 Ljubljana; † 1885 Prague) and Friedrik (* 1832 Ljubljana). Wilhelmine married her father's assistant the psychiatrist Josef Czermak (* 1825/26; † 1872). After his PhD with Boltzmann focussed on Maxwell's kinetic theory of gases, their younger son Paul Czermak (* December 27, 1857 Brno; † 1912 Innsbruck)²⁴¹⁶ taught in Graz University and replaced the Lower Carniolan Ignac

Klemenčič (* 1853; † 1901) in the University of Innsbruck in 1901. Paul Czermak and Klemenčič's research of the interference of electrical waves in air influenced Tesla's inventions.

when Nikola found Heinrich Schwarz's letter in the attic of the flat of his parents in Gospić school. Tesla did not listen to Schwarz's lectures, but he did the exams in the class of his successor in the position of Dean of the Faculty of Chemistry and Technology (1876-1878), the beginner of physiological chemistry Richard Maly (1839; † 1891).



Figure 18-46: After Tesla was expelled from the Polytechnic, the former Graz rector chemist Heinrich Schwarz gave a lecture on the Philosophy of Technology on December 20th, 1879 in front of the Styrian Natural Science Society.²⁴¹⁷ Tesla's Graz rector in 1876/77, the president of Styrian society and professor of technical chemistry Heinrich Schwarz (1824 Eisleben in Prussia-1890 Eberswalde in Prussia), discussed the philosophy of technics which always interested Tesla very much. Schwarz's speech was summarized on page LXV. Tesla did not hear the speech as he was already exiled to Gospić earlier in that year. Heinrich Schwarz taught in Graz from 1865 until his death and published a lot of popular works like *Die Chemie und Industrie unserer Zeit, oder die wichtigsten chemischen Fabrikationszweige nach dem Standpunkte der heutigen Wissenschaft: in populären Vorträgen in Wroclaw in 1857-1858.*

²⁴¹⁵ Fran Viljem Lipič, *Observata de metritide septica in puerperas grassante*, Wien 1823.

²⁴¹⁶ Not related to Moravian mineralogist Gustav Tschermak Edler von Seysenegg (* 1836; † 1927). <http://www.deutsche-biographie.de/sfz9124.html>; http://www.tigis.cz/images/stories/psychiatrie/2011/04/02_czech_psych_4-11.pdf pp. 183, 185-186, consulted on February 2, 2013; Pavel Čech, *Rodovniški pregled Lipičevih prednikov in potomcev. V: Osnovne značilnosti dipsobiostatike* (Fran Viljem Lipič), Ljubljana 2005, pp. 124, 140.

²⁴¹⁷ Schwarz, 1879, LXV

In his second year in Graz, Tesla first wanted to be brilliant again, but his experience at home with his worried father convinced him that he should take it easy. Therefore, Tesla performed excellent exams only in Allé's mathematics III, in Stark's technical mechanics and in Pöschl's technical physics. Tesla announced his studies of Stark's analytical mechanics too but did not show up at the exam;²⁴¹⁸ this could have caused later anger of the ignorant rector Stark. At the same time, Tesla successfully passed the exam of Rogner's composition of numbers and selected chapters from political arithmetic, which was then popular useful title for statistics. Tesla also intended to learn Pöschl's fundamentals of wave theory, Karl Pelz's Theory of conic sections and the lectures of Johann Rumpf on mineralogy.²⁴¹⁹ Unfortunately, Tesla did not come to those exams. Karl Pelz published on similar advanced topics in his book *Die Axenbestimmung der Kegelflächen zweiten Grades* in Vienna in 1874. In 1876, Pelz published in program on the Real School of the Habsburg Silesian Duchy of Teschen (Cieszyn, Těšín). From 1878 to 1880, Pelz was the assistant professor in Graz and taught until 1896, while his mathematical books were published also in Prague in 1893 and 1895. Pelz polemized with the painter Karl Wilhelm Pohlke (1810 Berlin-1876 Berlin) who established an important geometric theorem for the axonometric projections. Johan Rumpf taught from 1875 to 1911. From 1st October 1886 until 30th September 1887 he was the rector in Graz. Tesla's ideas of crystals as the kinds of living matter were certainly based on Rumpf's lectures and Rumpf's book *Über den Krystallbau des Apophyllits* published in Vienna in 1880.

In his third academic year 1877/78 in Graz, Tesla again planned many mathematical or engineering exams, as well as French and English language exams, but Tesla did not appear on any test of his knowledge. Karl Pelz's continuation of conic sections was among those lectures, as well as different useful aspects of general and applied mathematics with determinants or analytical mechanics. and general and special (Spezielle) Theoretische Maschinenlehre. The mathematical lectures should have been especially useful for Tesla and his later misunderstanding of Einstein's theories. The gambling and fine Styrian wine looked like much nicer to the extravagant Tesla of

those days even if there were not much Styrian girls involved.

Jakob Pöschl (* 1828; † 1907 Graz) of Tyrolean family was known among students for his unchanged evergreen suit that he wore for two decades; a similar reputation dogged his peer from the University of Graz, Simon Šubic. Between 1865 and 1867 Pöschl was the first dean of the Graz Mechanical School (Maschinenbauschule), the dean of general lectures in 1870/71, and the rector of all Technical Hochschule in Graz in 1871/72. During Tesla's studies in Graz Jakob Pöschl served as the dean of Tesla's Faculty of Chemistry and Technical Sciences between 1878 and 1888 with some intervals in-between. Pöschl became an Imperial Adviser. With his one generation younger love Magdalena born Nömayer (* 1849) Pöschl had two sons: the professor of Chemistry and rector of the High School of Commerce in Mannheim Victor Pöschl (* 1884; † 1948) and the University of Karlsruhe professor Theodor Michael Friedrich Pöschl (* 1882; † 1955). Jacob's grandson was the classic philologist Viktor Pöschl (* 1910; † 1997).²⁴²⁰ Jakob Pöschl was an ordinary highly respected guy of his class which provided absolutely no reason for his quarrels with Tesla. Except for the fact that Tesla in his early twenties was an impossibly difficult student as he claimed to be cleverer than his professors who were nearly of the age of Tesla's father. There are just few professors who could understand that heavy challenge of having a real genius in their class, and Jakob Pöschl did not happen to be one of those rare exceptions. Einstein had no better luck with his Zürich professors Heinrich Friedrich Weber and Jean Pernet.

At the University of Graz, Tesla probably met a friend of his high school professor Sekulić, the associate professor of meteorology and thermodynamics Simon Šubic. Perhaps he even knew Klemenčič who tried to replace the retired Pöschl in vain in 1888. Klemenčič's students' measurements of the speed of electromagnetic waves between 1871/72 and 1875/76, which he continued as Boltzmann's demonstrator in 1877/78, must have been extremely interesting for Tesla. At

²⁴¹⁸ Marinčić, 2006, 36.

²⁴¹⁹ *Mitt. nat. Ver. Steier.* 1882, p. XII.

²⁴²⁰ www.deutsche-biographie.de/sfz96586.pdf, Retrieved on 20. 1. 2013.

the beginning of Tesla's studies, Ludwig Boltzmann returned to Graz as one of Europe's leading experts in the new Maxwell's theory of electromagnetism which enabled Tesla's inventions. Among the most famous inhabitants of Graz, in the era of Tesla's studies was a mathematician and chief school inspector Franc knight Močnik who retired in 1871. Tesla was surely aware of Močnik's influence as a schoolboy in Lika, but not more than a lecturer at a lower real school in Gospić after his expulsion from Maribor. The Graz student Tesla read the works of William Crookes about radiation in a vacuum cathode ray tube and the alleged fourth aggregate state of matter. Three decades later, Tesla visited old Crookes in London, where they talked more about William's influential reverberating research of spiritism than about vacuum techniques.

On 28 February 1870, Pöschl lectured on a "flying flame" at the Styrian Natural Science Society. The phenomenon was described by the chemist Bryan Higgins (*1737/41 Collooney in Sigo in Ireland; † 1818/1821) as a "chemical harmonic" in 1777 after Higgins studied in Leyden with Pieter Musschenbroek's heirs and before Higgins visited Russia. Among Higgins's students in his School of Practical Chemistry in London was Higgins' later antagonist the chief promoter of electrostatics Joseph Priestley in 1770s. Faraday observed the stratification of the flame projected by sunlight as a shadow on white paper. In 1818 Faraday published his first physics discussion "about the flying flame" of various gases in the tube and encouraged many further researchers. In 1845, Faraday as a greatest Tesla's model began to explore the "magnetic properties of gases", and his discoveries were supplemented by the pioneer of cathode ray tubes Plücker.

Diamagnetism of the flame was discovered by a Genova university professor of physics, a provincial of Piarists Michele Alberto Bancalari who was born in 1805 in Chiavari by Genova. He reported on his discovery to a physics group of the 4th assembly of Italian naturalists in the debate on the universality of magnetism in Venice on September 21, 1847. Three months later, Zantedeschi added his own research as a professor of physics and mathematics at Lyceum of St. Catherine in Venice and a member of the Institute there. Diamagnetism of the flame had roots in Kepler's theory of the magnetic Sun that attracts the planets, but Poggendorff as the editor of the

German translation of Zantedeschi's paper disliked that connection. Zantedeschi sent a copy of his discussion to Arago in Paris and to Faraday to London, knowing about Faraday's research of diamagnetism. In December 1847, Faraday published his experiments with Richard Taylor, the editor of Phil. Mag. Faraday found that heated air and flames are more diamagnetic than the cooled air and are therefore separated from it during their flow to the pole of the magnet. Bancalari's discovery convinced Faraday about the temperature dependence of diamagnetism, which he noticed only in gases, but not in solid matter and liquids. Faraday made numerous comparisons between the diamagnetism of various gases and its dependency on the temperature. After recovering from illness, Faraday continued the research of diamagnetism of gases at normal temperatures with atmospheric measurements three years later.



Figure 18-47: Portrait of Tesla's Professor Pöschl. His suit is probably the same as always

The flame had also attracted the attention of young Karl Ferdinand Braun, who continued Hittorf's (1869) research of increased conductivity of flame in one direction in Geissler's electronics cathode ray tube at the University of Marburg between December 1877 and 1878. Braun was Kundt's assistant professor in Strasbourg university between 1880-1883 when Tesla and Puluj frequently visited there. Braun was probably not Tesla's best friend but figured more as a competitor.



Figure 18-48: Pöschl's discussion of the "flying flame" in the collection of the Styrian Science Society, whose secretary Pöschl was at that time²⁴²¹

In 1878/79 just after Tesla escaped from Graz, Pöschl's Graz lectures of technical physics were collected by Pöschl's student Tesla's younger classmate, later assistant electrician engineer Josef Schaschl (Šašel, Šašl, * 15. 2 1860 Slovenji Plajberk (Windisch Bleiberg, Svinčnica); † 1908/9).²⁴²² Josef Schaschl (Šašel) was a descendant from the famous gunsmith family in the areas of Borovlje (Ferlach) south of Klagenfurt, but not in Ferlach, Kappel by Drau River (Kapla) or Glainach (Glina) where the relatives of J. Stefan's mother used to produce guns. His relative was the ethnologist Josip Šašel (Wieser, 1883, Windisch-Bleiberg-1961 Municipality of Prevalje). Josef Schaschl's other relative gunsmith-painter Jakob Šašel (Schaschel, 1832 Kappel (Kapla pri Borovljah)-1902 Karlovac) worked as the famous gunsmith in Karlovac after 1857. Tesla knew him very well and in Karlovac Tesla frequently met his son the writer-priest Jakob Šašel (13th April 1862 Karlovac-1911 Mahično suburb village of Karlovac). Josef Schaschl himself later published first-class work about the electrical engineering, coatings of metals using galvanic current and most of all on the high-pressure two-cylinder steam engine of Tesla's "friend" Westinghouse in the monthly magazine of the Hydrographic Institute in Pula.²⁴²³ The marine electrical engineer J. Schaschl made the devices convenient for ships without the use of electric motors, so he did not mention his former classmate Tesla. In July 1888, George Westinghouse (* 1846; † 1914) approved and then applied Tesla's American patents for induction

motor and transformers. J. Schaschl (Šašel) was not a member of the Styrian Natural Science Society, despite the leadership of his superior Pöschl in Styrian Natural Science Society.

Schaschl (Šašel) also never habilitated or taught in Technical Hochschule of Graz. After Pöschl's retirement, Schaschl (Šašel) worked as an assistant in electrical engineering in Pula in 1889. On October 27, 1890 he became an engineer of the second grade in marine office of Technical office in e) department of electrotechnics of Military-Marine together with Wladimir Čermák, while Ernst Codelli served as Marine-Commissary adjunct of 1st class and a member of Marine-Control-Office in 1893-1896 and dr. Joseph Potočnik was the physician of Marine Staff headquarters. On 1 November 1894 Josef Schaschl (Šašel) became a first-class engineer in marine office of Technical office in e) department of electrotechnics of Military-Marine where he served under his Jewish boss Moses Burstyn (1841 Lvov-1908) who invented dry cell as the Senior engineer of 2nd class promoted into 1st class on 1. 5. 1896.²⁴²⁴ Josef Schaschl (Šašel) became a senior engineer on November 1, 1906, but he was listed no more in Marine in December 1907. Among Josef Schaschl's (Šašel) collaborators in Pula was the physician general Jožef Potočnik (Josef, 1841 Zgornji Razbor near Slovenji Gradec-1894 Pula), the father of the famous Herman Potočnik Noordung. Jožef Potočnik worked in Pula military bases. He fought at Vis under Tegetthoff's command and became general; he was the father of the inventor of the geostationary satellite the engineering captain Herman Potočnik - Noordung (1892 Pula - 1929). While Potočnik's family name was noted in Slovenian transcription in Marine official listing, Schaschl (Šašel) preferred to use the German transcription as Schaschl, which echoes the national consciousness of both guys. In autumn 1887, Peter Salcher continued his experiments in Pula. The naval officer Karl Josef baron Codelli (1846-1878 Pula) served in Pula. After his graduation, between 1894 to 1897, his son, a navy officer inventor of the television Anton baron Codelli (1875-1954) also served in Pula as See-Aspirant ranged in 1. 10. 1894 among See-Cadets of 1st and 2nd class as Josef Schaschl's

²⁴²¹ Pöschl, 1870, 91.

²⁴²² Pichler, 2004, 2.

²⁴²³ Schaschl, 1886; Schaschl, 1893. 3.

²⁴²⁴ *Rang- und Einteilungsliste der k. u. k. Kriegsmarine* 1892, 37, 92; *Rang- und Einteilungsliste der k. u. k. Kriegsmarine* 1908, 106.

(Šašel) younger colleague electrician.²⁴²⁵ In any case, we can think that the Habsburg command of military Navy in Pula has become obsessed with new technical ideas, including Slovenian ones.

Table 18-5: Pöschl's lectures on the use of electricity included many Tesla's favorite areas

Electrotechnical Telegraphy
Electrical Watches
Electromagnetic Machines
Galvanoplastic
Production of Conductors for Lightning Rods
Electric lightning ignition techniques for underwater mining

Table 18-6: Pöschl's lectures about thermodynamics

The science of fuels
Dynamics of gases in pipes
The theory of tunnels and chimneys
Stoves and furnaces, gas production
Dynamics of heat, radiation and transmission
Boilers and steam generators
Drying and evaporation equipment
The heating and ventilation of the houses

In 1879, according to Josef Schaschl's (Šašel) notes, Pöschl lectured on the "Use of electricity" and "Use of thermodynamics", but he did not have enough time for the announced "use of Optics". He could have presented his studies of light in lectures

²⁴²⁵ Schaschl, Josef. 1878/79. *Technische Physik nach den Vorträgen des Herrn J. Pöschl k. k. ö. o. Professor and der k. k. technischen Hochschule in Graz 1878/79*, finished with date August 13, 1879, Universitätsbibliothek der TU Graz; Schaschl, Josef. 1886. Die Galvanostegie, mit besonderer Berücksichtigung der fabrikmässigen Herstellung dicker Metallüberzüge auf Metallen mittelst der galvanischen Stromes. *Elektro-technische Bibliothek*, 30. Bd. Wien: Hartleben, F. Vieweg & Sohn; Schaschl, Josef. 1893. Der Westinghouse-Motor. *Mittheilungen aus dem Gebiete des Seewesen*. Pula & Wien: Carl Gerold's Sohn, 21/4-5: 1-20; Wolfgang Wallner. 2013. *200 Jahre Technik in Graz*. Eine Geschichte der Technischen Universität Graz von ihren Anfängen bis in das Studienjahr 2011/12. Graz, Verlag der Technischen Universität Graz; *(Militär-)Schematismus für das kaiserliche und königliche Heer und für die kaiserliche und königliche Kriegs-Marine* für 1893, Wien: Staatsdruckerei, January 1893, 1101, 1121, 1124, 1125; für 1896 in December 1895, pp. 1063, 1078, 1087, 1088; für 1901 in December 1900, p. 1203; für 1908 in December 1907; *Rang- und Einteilungsliste der k. u. k. Kriegsmarine* Wien 1892- pp. 37, 92; 1908 p. 106; <http://history.tugraz.at/lehrende/dozenten/>

on Theory of Waves, which Tesla did not attend as a sophomore.

On 25 January 1868, in front of the Styrian Science Society, Pöschl demonstrated experiments on an underwater telegraph cable over 2,000 miles long between Ireland and Newfoundland. New Yorker Cyrus Field project succeeded on September 1, 1866 with the help of William Thomson, later Lord Kelvin. They used lower voltages than in the previous failed trials.

At the end of 1875 or perhaps hardly in January or February 1877, among other things, Pöschl in Tesla's class tested brand new dynamo. He used DC of 400 A, 25 V by design of Zenobe Gramme and his entrepreneur Hippolyte Fontaine (* 1833 Dijon; † 1910 Hyères on Mediterranean coast). The item was invented in 1873 in the Edison's Parisian Laboratory, and sent the same year to illuminate the Viennese World Exposition. During his classroom lesson Pöschl sharply rejected Tesla's novelty about the adaptation of the Gramme's invention for alternating current.²⁴²⁶ Pöschl was an expert and Tesla was just a kid! At the same time, on 11 November 1875, Pöschl introduced Gramme's invention to the Styrian Natural Science Society.

Gramme's electric motor was tested as the power supply for lighting of the Heilman factory in Mühlhausen in eastern Franconia on a three-state border with France and Switzerland.²⁴²⁷ The textile manufacturer Johann Heilmann (* 1771; † 1834) developed their family company. He was followed by his older son Josua Heilmann (* 1796; † 1848) with the invention of machine embroidery. The invention brought the money to Josua's son Johann Jacques Heilmann (* 1822; † 1859), and especially to his grandson Jean-Jacques Heilmann (* 1853, Mühlhausen; † 1922), the French inventor of modern electric locomotive and steam-electric car.

Pöschl's apparently first-class international connections enabled his forecasting the transition of steam engines to electric motors. He immediately began to calculate the savings in terms of coal consumption of the steam engine compared to the expensive maintenance of zinc-carbon galvanic battery with acids or stearin

²⁴²⁶ Marinčić, 2006, 38; Cverava, 2006, 32; Mayer, 1996, VI/67; Mirčevski, Cundev, Andonov, 2007, 20

²⁴²⁷ Pöschl, 1875, 70.

candles. He anticipated the conversion into alternating current with brushes, which Tesla sharply disliked due to unwanted losses by sparking.

Pöschl announced the distribution of electricity through telegraph cables, which soon no longer helped. In favor of Tesla's later Niagara project, Pöschl announced power plants because he was aware of the daily losses of 3,000 horsepower by the lifting locks via intermediate agricultural consumers in Port-à-l'Anglais near Paris, built in 1864 and repaired in 1869. The lifting would be much cheaper with an electric motor, powered through the conductors of current nearer to Paris.²⁴²⁸ Of course, Pöschl knew that Aristide Bergès (* 1833; † 1904) set up the first hydro power plant in Lancey, 15 km northeast of Grenoble, for the paper mill operation on September 28, 1869.



Figure 18-49: Pöschl on the Belgian Gramme's electromotor, whom by the way he introduced as Frenchman.²⁴²⁹

In his lectures on Electromagnetic Machines, Pöschl certainly also showed Geissler's or even Crookes' vacuum tubes. Tesla knew a lot about them already from Sekulić's lectures in Rakovac. After Pöschl's retirement he left the Styrian Science Society. In 1888 he was replaced by the former Toepler's and Boltzmann's assistant Andreas' grandson Albert von Ettingshausen. Obviously, the candidate Klemenčič was not so pleasing, since his Slovenan nationalism was not welcomed at the leading academic positions in nationally divided Styrian Graz. With Ettingshausen in Graz, a new wind has blown up.

²⁴²⁸ Langlais (Pöschl, 1875, 71).
²⁴²⁹ Pöschl, 1875, 68.

A dozen years after Tesla's studies Karl Pichelmayer (* 1868; † 1914) become a mechanical engineer and subsequently Ettingshausen's electrical engineering assistant.²⁴³⁰ Of course, this could also happen to Tesla, although Europe would be even less hospitable to Tesla's precious gigantic towers than the USA.

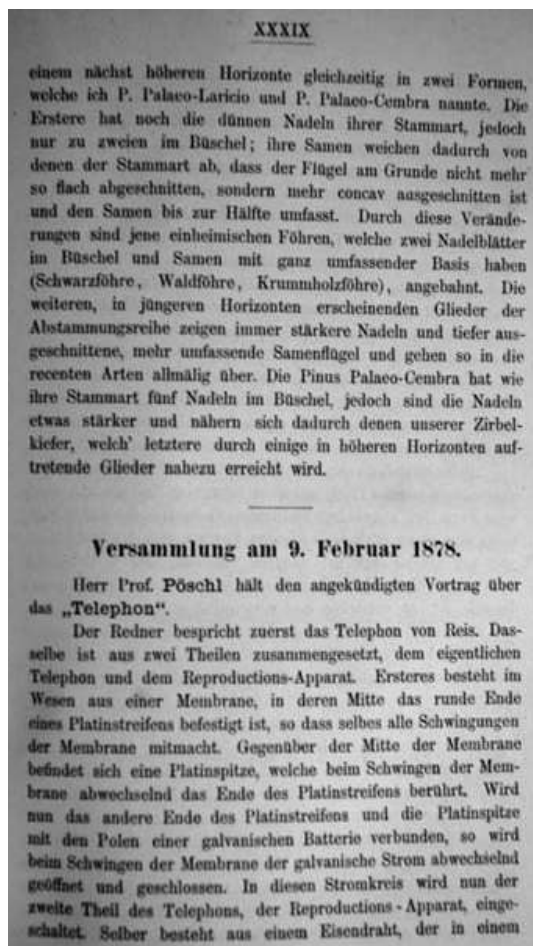

Figure 18-50: Tesla's professor Pöschl on phones at the end of Tesla's studies on February 9, 1879; the first part of the lecture in front of the Styrian Science Society.²⁴³¹

Ettingshausen soon assumed a new modern lecturing on Electro-technique, and in the inaugural rector's speech at the Polytechnics Graz, he remembered Tesla's former schooling in Graz in 1893. On November 11, 1894, Ettingshausen, with the general approval of the Styrian Natural Science Society, showed Tesla's image of the high voltage alternating current,²⁴³² which proved again that Tesla has fully established himself in his Graz Alma Mater, unfortunately a decade too late. The

²⁴³⁰ Cverava, 2006, 28; Flamm, 1995, 101, 290–291.
²⁴³¹ Pöschl, 1879, 39.
²⁴³² Ettingshausen, 1895, LI.

retired Professor Pöschl did not publish much about sciences anymore in those times.

Despite Pöschl who had somewhat strange relations with Tesla, Tesla liked two other important teachers of mathematics in Graz. Pöschl did not publish much, except in the Proceedings of the Styrian Natural Science Society, while Moritz Allé published with the Viennese Academy and by the Prague Mathematical Society. Moritz Allé began his studies in Vienna and got his Ph.D. from the University of Kiel in 1860. Allé got his first jobs in astronomical observatories: in 1856-1859 in Vienna, in 1859-1862 in Krakow, and in 1862/63 in Prague. He got the chair of mathematics in Graz Polytechnic in 1867 and became rector in 1875/76, just in the time when Tesla matriculated. After Tesla left Graz, Allé became the professor of mathematics under the rector Ernst Mach in recently split German part of the University of Prague in 1882, but in 1896 he left for Viennese Polytechnic.

Other Tesla's mathematical teacher was Johann Baptist Rogner (* 1823; † 1886) who graduated at the Viennese Polytechnic in 1845. He was hired as the assistant lecturer of mathematics there and later taught in Graz High Real School. In 1851 he became the very first assistant professor (docent) of higher mathematics in Graz Polytechnic and he got the chair of elementary mathematics in 1866. In 1874 Rogner was employed as the professor of higher mathematics just before Tesla matriculated. He was also the director of proof-examinations of professors at Graz High Real Schools and Merchants-Commercial Schools. In 1869 Rogner discussed the new inventions of calculator in front of Styrian Naturalists Society whose member he was.²⁴³³ He criticized the calculator on tooth wheels of the factory owner Peter Hlubek from Villingen in the Land of Baden. A similar invention received US patent no. 30264 on 2 October 1860. In 1875 it was probably the same P. Hlubek who patented a piston pump in Vienna.²⁴³⁴ Rogner also wrote Kepler's biography.²⁴³⁵ Kepler

²⁴³³ Mittheilungen des naturwissenschaftlichen Vereines für Steiermark (Mitt.nat.Ver.Steier.), (1882), p. XIX.

²⁴³⁴ Flamm, 1995, 301; Rogner, 1869, XLIII; rechnerlexikon.de/fr/artikel/Patent:US30264, www2.landesarchiv-bw.de/ofs21/olf/struktur.php?bestand=17506&sprungId=329261&letztesLimit=suchen, Retrieved 3. 3. 2013

²⁴³⁵ Johann Rogner, *Ueber Johann Kepler's Leben und Wirken. Festrede den 15. October 1871 bei der Vorfeier des*

was certainly the most important scientist who ever worked in Graz and Tesla inherited many Keplerian mystic visions. Did Rogner tell Tesla that Protestant Kepler planned to take Zrinski's shelter from hostile Graz based Catholics in Tesla's own Military Border in modern Croatia but eventually reached just Petanjci in now Slovenian Prekmurje on September 28, 1598?

From 1866 to 1870, Tesla's professor Josef Bartl (* 1850, Friesach north of Klagenfurt; † 1925, Graz) studied at the Polytechnic in Graz, and in 1875 he began teaching as an adjunct there. He habilitated in 1878 when Tesla had already left Graz. Between 1886 and 1890, Bartl lectured at the Polytechnic in Brno, and then returned to Graz and published *Die Berechnung der Zentrifugal-Regulatoren* in Leipzig with A. Felix in 1900. Ten years later, Bartl published *Zur Theorie der Zentrifugalpumpen*.



Figure 18-51: Tesla's Graz Mechanical Engineering Professor Josef Bartl

18.5.9 Tesla in Maribor

In early 1876 in Graz Tesla lived in high first floor (*Hochparterre*) in Attemsgasse No. 8 of Graz Geidorf district. The street was called after the counts of Attems who possessed their huge manors in Lower Styria and in Habsburg Littoral. In 1875/76 Tesla's roomie was the second-year student of jurisprudence, history and geography the Bosnian Kosta Kulišić who later became the

300jährigen Geburtstages Kepler's zu Schloss Mühleck nächst Graz gehalten, Graz 1871, 16 pages.

professor at Serbian Maritime School in Srbina of east Herceg-Novi (1 October 1881-1 April 1883), at Grammar School Kotor, at Dubrovnik, at Split in 1900, and at Sarajevo but not at first Gymnasium where Zoch used to be a director and where Gavriilo Princip studied in 1910-1912. Because of money troubles Tesla later moved to Hans-Sach Gasse, Jahngasse 5, and Heinrichstrasse 11 in Graz. Two of his student flats still exist, but other two were replaced with new buildings.²⁴³⁶ Tesla excellently studied his first year in Graz and was good enough in his second year, but he made no examinations in his third year until January 1878 which caused his move to Maribor. Tesla never abandoned his later famous way of using official clothes and his Graz tailor was Jožef Murko from Maribor. After the advice of the law student, later military priest Milan Panajotović († before 1936), Tesla borrowed money from Jožef Murko. Kosta Kulišić also borrowed from Murko and paid him extremely high interests of over 9%. Tesla had no better luck and soon went broke. Once he joked that Murko should pass Tesla's mathematical exam to get Tesla's stipend of 210 florins. In 1868 Habsburg's laws against usurers like Murko were abolished. In 1871, Jožef Murko worked as a tailor (*Schneidermeister, Kleidermacher*) in Bischofplatz No. 2 in Graz, but he moved to Bürgergasse No. 18 in inner city of Graz downtown where he lived in the years 1877-1886. Josef Murko was not buried after a funeral ceremony in Graz-Dom church which served his domestic areas of Bürgergasse, nor in Graz-Mariahilf church nearby. Additionally, starting in 1882 his Graz relative Jakob Murko (7. 7. 1851 Ptuj-16. 2. 1916 Graz Schlossberg (City Hill) no. 36) was tailoring in Maifredyngasse No. 10 in Graz. On 8. 11. 1880 in Graz Jakob Murko married Maria Meichenič widow Malleg.²⁴³⁷

²⁴³⁶ High School; *Hof- und Staat...* Wien 1900, p. 820; Dan Mrkić, *Nikola Tesla - evropske godine*, Beograd 2004, p. 32; Kosta Kulišić, *Sedamdesetpetogodišnjica Nikole Tesle – Buran studentski život i prva stvaranja*, Politika (Beograd), July 19, 1931, p. 10; Kosta Kulišić, *Nikola Tesla. Njegov djački život i naučni rad [u kratkim crtama]*, Sarajevo 1936, p. 9; Cverava, *ibidem*, p. 34.

²⁴³⁷ Andrej Pančur, *Opis oderuhov v 19. stoletju na Slovenskem*, *Acta Histriae*, 15 (2007), 1, p. 182; Vladimir Pištalo, *Tesla, portret med maskami*, Ljubljana 2012, p. 194; Cverava, *ibidem*, p. 37; Kulišić, *ibidem* 1936, p. 15-16; Branimir Jovanović, *Tesla: duh, delo, vizija*, Beograd 2001, p. 50; *Grazer Geschäfts- und Adreß-Kalender*, (1871); (1877); (1879), pp. 124, 221; (1881), pp. 129, 252; (1882), pp. 132, 254; (1883), pp. 133, 256; (1884), pp. 138, 266; (1885), pp. 146, 265; (1886), pp. 147, 284; (1887), pp. 148,

Tesla's empty pockets forced him to leave Graz; he did not have enough money to continue his studies, while at the same time he tried to avoid military obligations. Tesla had to abandon the city of Graz where his indebtedness to Murko troubled him. His incomes were too scarce to pay Murko off and to continue his studies. At the same time, Tesla tried to avoid military service which he and his father disliked. The Army threatened him because Tesla received the stipend of Military Border according to the order issued on September 22, 1876. The stipend was eventually achieved with a little help of the husband of Tesla's aunt Stanka the colonel Dane Branković whose guest was Tesla during his studies in Rakovac. The Military Border authorities agreed to support three years of Tesla's studies in yearly amounts of 420 forints payable in two rates on the end of each semester. Tesla had to provide the proofs of the exams accomplished each time before he could get the fellowship money. The main problem was the part of the agreement which demanded at least eight years of Tesla's service for the military after he finishes studies.²⁴³⁸

As a child of Military Border folks, Tesla was a part of military unit as soon as he was born despite of the fact that Habsburg authorities were abolishing the Military Border system as an old-fashioned relict in Tesla's times. The lost military jobs soon forced majority of Military Border people to leave their native country with Tesla and Mihajlo Pupin somewhat included. But Tesla had his vision and didn't care much for any military appointment. To avoid the uniform or military border professorships, Tesla twice unsuccessfully asked *Matica Srpska* officials for their stipend. On October 14, 1876 as a student who finished the first year of Chemistry-Technological Faculty, Tesla applied for the first time, and he did it again in November 1878.²⁴³⁹ He was not successful in the first place because he already had a stipend while he was a priest's son and not some poor fellow. On the second occasion Tesla was probably already in Maribor but he pretended that he recovered from illness with a wish to continue the studies in Graz. The *Matica Srpska* officials eventually did not believe him, while nobody suspected that the young extravagant Tesla could be a genius. It is probable that Tesla spent

285; (1888), pp. 146, 284L *Graz Heilige Blut Sterbebuch* 25: 13, 584, 592.

²⁴³⁸ Marinčić, *ibidem*, p. 40; Cverava, *ibidem*, p. 29; Archiv, Technische Universität Graz.

²⁴³⁹ Cverava, *ibidem*, p. 36-38.

scholarships on gambling and had nothing left to pay for school fees for the third year of the Polytechnic.

Tesla certainly learned about Maribor from his Graz classmates. Tesla got his data from his several months younger classmate, the son of the Maribor regimental doctor, Ferdinand Wittenbauer (18 February 1857; † 1922, Graz). Early orphaned Wittenbauer had an uncle major who enabled his brilliant studies at the Graz Real School, which he completed in 1872. He studied for five years for a degree in the engineering department of the Graz Polytechnic which he received in 1879. In 1883/84 he visited Helmholtz and Kirchhoff, and in 1886 he took over Stark's Chair of Pure and Technical Mechanics and the Theory of Mechanical Engineering at the Polytechnic of Graz. There he became the beginner of the graphic methods of kinematical geometry and the rector of the Polytechnic in 1911/12. At the same time, he excelled as a lyricist and successful dramatist of student life. He described conflicts between nationality colored student organizations from a relatively sharp German nationalist position.²⁴⁴⁰ In 1901 he published a survey of turbines and pumps with elements of vacuum techniques.

In a letter dated 12 March 1878, the rector of the Polytechnic, Stark, informed the military authorities in Zagreb that Nikola Tesla was excluded from the list of students. On 31 March 1878, Zagrebians answered and asked the rector, until which day the Tesla scholarship was paid. Does Tesla really lie sick in the hospital, as Tesla's father claimed? On 15 April 1878 the Rector approved the payment of Tesla's scholarship until January 1878; but he did not believe that Tesla could be in the hospital or even anywhere near Graz. On 4 May 1878, the military authorities in Zagreb ordered the rector to stop paying Tesla's scholarship and inform Tesla about that decision.²⁴⁴¹

In the spring or at the latest at the end of 1878, Tesla left Graz. He was denied the grants because he did not pass any examinations in 1877/78; he no longer had a scholarship, and his father also

stopped sending his support. He could not, in any case, pay back debts to Murko. Tesla was depressed, and some acquaintances were afraid that he succumbed to suicide in the Mura River. Tesla's relative, Graz student of law Gjuro Banjanin had to search for Tesla; but it would be easier to find a needle in a haystack. Not later than November 1878 Tesla turned his legs to the south secretly; with the new railroad, he landed in the hourly rising second largest Styrian town of his days - Maribor.²⁴⁴²

Maribor schools of Tesla's times were attractive for Tesla although he probably didn't compete for a teaching job in Maribor because he did not finish his studies. The Maribor High Real School professors and students' libraries collected nearly 10000 books including most important electro-technical and vacuum technique journals until 1914. The presents of Essl, Jonasch, and Ferlinz were formidable. The Library of the Maribor Real school of Tesla's days offered the descriptive geometry of Jules-Antoine-René de la Gournerie (* 1814; † 1883) published for the first time by Parisian Mallet-Bachelier in 1850-1864. They acquired the *Zeitschrift für mathematischen und naturwissenschaftlichen Unterricht: ein Organ für Methodik, Bildungsgehalt und Organisation der exakten Unterrichtsfächer an Gymnasien, Realschulen, Lehrerseminarien und gehobenen Bürgerschulen* (1869-, Berlin/Leipzig: B.G. Teubner), *Zeitschrift für analytische Chemie* (1864-1889, Wiesbaden: C.W. Kreidel, edited by C. Remigius Fresenius (* 1818; † 1897)), *Chemisches Centralblatt* (1856-1969. Berlin: Deutsche chemische Gesellschaft), *Naturwissenschaftliche Wochenschrift: allgemeinverständliche Wochenschrift für sämtliche Gebiete der Naturwissenschaften* (1887-. *Deutsche Gesellschaft für Volkstümliche Naturkunde in Berlin*, Berlin: F. Dümmler & Jena: Fischer), *Zeitschrift für den physikalischen und chemischen Unterricht* (1887/88-1943. Berlin: J. Springer, edited by Friedrich Wilhelm Paul Poske. They offered to the local scholars the works of Ernst Mach; Bernhard Schwalbe; H. Matthée; K. Metzner; Otto Ohmann), *Österreichische Chemische Zeitung* and for Tesla especially important reports on Viennese Stefan's exhibition in *Zeitschrift für Elektrotechnik* (1883. *Organ des Elektrotechnischen Vereines in Wien*. Wien: Spielhagen u. Schurich) and *Internationale*

²⁴⁴⁰ Hartman, 2001, 16; Wittenbauer 1903, Wittenbauer, 1905.

²⁴⁴¹ Pichler, 2004, 4; Richter, 2007, 338.

²⁴⁴² Mrkić, 2004, 34-35; Jovanović, 2001, 51.

Elektronische Zeitschrift und Bericht über die elektrische Ausstellung in Wien (1883. Wien: A. Hartleben's Verlag. In those items J. Stefan published a lot of contributions. Maribor school also had *Internationale Zeitschrift für die elektrische Ausstellung. Wochenschrift für die Gesamtinteressen der internationalen elektrotechnischen Ausstellung, Internationale elektrotechnische Zeitschrift und Bericht über die elektrische Ausstellung in Wien*, edited by J. Krämer and Ernst Lecher. They acquired the works about the use of electricity, the production of electrical light, and about telegraphs. For students in Maribor, they kept Edmund Hoppe's (* 1854) *Geschichte der Elektrizität* published in Leipzig by J.A. Barth in 1884.

Similarly, there was well-staffed Gymnasium Library of Maribor which was more focused on humanistic. There they acquired the authors like Laplace, Lagrange, Jurij Vega, Crelle, or Duhamel. Certainly, all School Libraries restricted their offer to the readers connected with schools.

As the passionate reader and patriot Tesla may have joined the (*National*) *Slovanska čitalnica* (Slavic Reading-room) of Maribor established in 1861. There they offered the journals reading room and library in pub *Pivnica pri moki* of the lady Marija Schraml. On January 9, 1879 the elected board members of *Slovanska Čitalnica* were Kalčič, Holobar, Škoflek, Dominikuš, Ambroš (Valentin Ambrusch as professor of Maribor Grammar School in 1879), Srnec (Serneck), Brelih, and Ulrih.²⁴⁴³ In 1881 *Slovanska Čitalnica* had eighty-four members carefully chosen among the local well-to-do. Later they read there the journals *Srbski dnevnik* (*Srbski dnevnik. List za politiku, prosvetu, privredu, radinost i trgovinu* owned by baron Feodor Nikolić (* 1836; † 1903) and edited by Aleksandar Stojačković in 1888), *Hrvatska vila* (Sušak/Zagreb, 1882-1885) or *Slovan* (Ljubljana 1884-1887). The editor of journal *Zora* was Janko Pajk (* 1847; † 1899), who was the owner of Maribor *Narodna Tiskarna* where he also printed the liberal daily *Slovenski Narod* which began with the three issues per week in 1868 and continued up to the war years of 1943. Tesla was probably interested in Josip Križan's papers or in M.J. Kokalj's article about telephone which discussed

Bell's patent and recent experiments on the line Graz-Maribor-Klagenfurt published in *Zora*.²⁴⁴⁴

Tesla could have used the commercial lending library of Maribor printers Edvard Janschitz (* 1882) and his son-in-law Leopold Kralik with 5000 volumes available. The Reading and educational society *Theater- und Casino-Verein* was also appealing despite of its German spirit. Already in Tesla's times the lending library of Railway Society offered 1500 books, but eventually just to its employers for a monthly fee. The Madame Dirnböck from Graz, whom Tesla could have already met in Graz, opened Maribor branch of her lending library in 1869. After Tesla's depart the libraries of bookseller Max Isslin (Islin) and the branch library of Graz bookseller Josef Kienreich prospered in Maribor. In one way or another Tesla probably followed the quarrels focussed on the monument of bishop Martin Slomšek with Slovenian inscription in Maribor Cathedral erected on June 24, 1878.²⁴⁴⁵ It was the greatest event of the era and Tesla certainly supported the Slavic feelings of Slomšek and his fans.

The modern science was held in the high esteem in Maribor High schools. After his undergraduate measurements of diffusion of gases in J. Stefan's Viennese lab, the Maribor professor Vrečko published mostly on mathematics including Jurij Vega's biography. For his unofficial assistant he picked up his High School student Karl Heider (* April 28, 1856; † 1935) who was just several weeks Tesla's senior and later became the famous zoologist. Just before Tesla's arrival Heider and his classmates in their homes enthusiastically constructed their own galvanic batteries in late November 1872.²⁴⁴⁶

Vrečko's colleague was Boltzmann's brother-in-law and collaborator Šantel who began his pedagogic career in 1869 in Maribor Gymnasium where he taught the future schoolmaster of Maribor Teacher's preparatory college Henrich

²⁴⁴⁴ M.J. Kokalj, *Telefon ali Daljnoglasnik*, *Zora*, 7, (1878) 3, February 5, p. 38, 39.

²⁴⁴⁵ Hartman, *ibidem* 2001, pp. 500-501, 518, 523-525, 531, 539, 542, 569, 597, 647-648, 768-769, 781, 798, 800-801, 803-804, 806, 808.

²⁴⁴⁶ Bruno Hartman, *Knjižnice v Mariboru*. In: *Maribor skozi stoletja, Razprave I* (ed. Jože Curk), Maribor 1991, pp. 697-698; Andreas Golob, *Mladostna leta v Mariboru. Dnevnik zoologa Karla Heiderja 1870-1873, Zgodovina za vse*, 19 (2012), 1-2, p. 96.

²⁴⁴³ *Slovenski gospodar*, 13 (1879), 2, January 9, p. 15.

Schreiner (* 1850 Ljutomer; † 1920 Maribor). In Maribor Šantel additionally studied mathematics, physics, and pedagogy for his Graz University exams scheduled for March 28, 1870.²⁴⁴⁷ In 1870 Šantel began to teach in Celje and on 23. 10. 1870 Šantel replaced his former teacher Essl in Maribor Gymnasium²⁴⁴⁸ after Essl got the directorship of Maribor Real School. Although Tesla never approved the entropy of 2nd law of Šantel's brother-in-law Boltzmann, Tesla was interested in Šantel's pre-Freud approach to the secrets of dreams in Šantel's *Poskus razkladbe nekaterih pomenljivih prikazni spanja in sanj*, as well as in Šantel's electric reflux of liquids, the use of solar energy for mechanical work and a new way of transmitting sound, which we know as Bell's phone since 1876.²⁴⁴⁹

Two Maribor professors in the time of Tesla's Maribor funny days published comparatively profound papers on optics and electricity: Jettmar wrote on genesis of waves after reflection and refraction on the plane surfaces, and later as Viennese professor published in top mathematical journals. In 1877 Nagy's replacement on the post of the president of Maribor Philharmonic Society. Spiller was thinking about the influences of new data of galvanic electricity on the theory of chemistry, and dozen years later Spiller analysed Maribor water sources like Baltasar (Knapitsch, Knappitsch) Knapič did in Ljubljana. Spiller's secretary and later vice-president of Maribor Philharmonic Society Britto published on congruity and mechanics. In their own ways, they combined the music of Philharmonic Society with physics²⁴⁵⁰.

Luka Lavtar published on kinetic theory during his stay in Ljubljana, but in Maribor he mostly discussed pedagogical puzzles. Luka Lavtar was a decade older than Tesla and among the rare Maribor natives who could understand Tesla's

²⁴⁴⁷ Šantel, *ibidem*, pp. 445, 452, 455.

²⁴⁴⁸ Šantel, *ibidem*, p. 457.

²⁴⁴⁹ Šantel, *Jahresbericht des K.K. Staatsgymnasiums in Görz: veröffentlicht am Schlusse des Schuljahres 1874*: 42–57; Šantel, 1883

²⁴⁵⁰ Heinrich Jettmar, 1879, 3-26; Jettmar, 1883, 3-39; Spiller, 1877, 3-28; Robert Spiller, *Beitrag zur Kenntnis der Marburger Brunnenwässer*, XIX. Jahresberichte der k. k. Staatsoberrealschule in Marburg, (1889), p. 8; Jasna Mlakar, *Razvoj mariborskega vodovoda*, *Zgodovina za vse*, 5 (1998), 1, pp. 8-9; Bruno Hartman, *Mariborsko filharmonično društvo, Časopis za zgodovino in narodopisje*, 78=43 (2007), 2-3, p. 90; Bruno Hartman, *Maribor-dogajanja in osebnosti*, Maribor 2009, pp. 185, 193-194.

ideas during Tesla's stay in Maribor. The Jew Hirschler disliked Slovenians and arrived in Maribor immediately after Tesla's depart. A dozen of years later in Marburg School Program Hirschler published the list of experimental methods for measuring the data about molecules within the kinetic theory. In 1891, Hirschler's paper *Methoden zur Bestimmung von Näherungswerten der Molekülgröße* certainly had much clearer physical background compared with the earlier Lavtar work and Hirschler also criticized some of the old ideas of Jožef Stefan's Klagenfurt teacher Karl Robida. The Slovenians disliked Hirschler and he was replaced by Karl Zahlbrucker, the older brother of the head of botanic part of Viennese Natural History Museum Aleksander Zahlbrucker (* 1860; † May 8, 1938). In his great school laboratory of Maribor Karl Zahlbrucker showed to his students the experiments with Tesla's rays²⁴⁵¹ with the little help of dr. Adolf Pečovnik (* May 25, 1883 Sv. Lenart). Pečovnik got his PhD after his studies of mathematics, physics and philosophy in the University of Vienna soon after Boltzmann's suicide on November 23, 1906.²⁴⁵² Later, Adolf Pečovnik became the school inspector of former Maribor area, and after second semester of 1939/40 he was a headmaster of Bežigrad High School (Gymnasium) in Ljubljana.

Knobloch came to Maribor from the Maritime Lower Real School of Pula. He became the president of Maribor German Gymnastic Society (1876-1886); and published a lot on geometry and on history of Maribor High Real School (1896, 1900) as Maribor High Real School schoolmaster between the years 1895-1907.

Before his appointment on the newly established High Real School of Maribor, the Mineralogist-chemist Anton Franz Reibenschuh was assistant in Polytechnic in Graz. In 1875 he became the professor on High Real School of Graz and researched in Chemistry Laboratory of Tesla's professor Richard Maly²⁴⁵³ until he was appointed director of High Real School in Graz before the year 1896. In 1868 he published the research of cave Pekel near Žalec (Sachsenfeld) of Lower

²⁴⁵¹ Bojc, *ibidem*, p. 145.

²⁴⁵² *Narodni list: glasilo Narodne stranke za Štajersko (Celje)*, 1 (1906), 5. November 23.

²⁴⁵³ Reibenschuh, 1883, 388.

Table 18-7: Comparatively successful physicists and mathematicians who taught in Maribor of Tesla's times

Name	Era	Maribor institution
Andrej Vrečko (Wretschko, * 1846)	1871-1873	Gymnasium p
Anton Šantel	1969/70, 23. 10. 1870-31. 5. 1872 m	Gymnasium m
Josef Essl (* 1830 Berneck (Pernek); † 19/4/1874 Maribor)	14/11/1856-1870 Gymnasium m , 20/10/1870-1874 director of Real School	Real School m ²⁴⁵⁴
Anton Franz Reibenschuh ²⁴⁵⁵	20/10/1870/71-	Real School p
Josef Jonasch ²⁴⁵⁶	20/10/1870-1879- came from the Orthodox High Real School of Černivci	Real School m , geometrical drawing, handwriting, German language, librarian
Josef Nawratil ²⁴⁵⁷	1871- Gymnasium m , geography, Natural Sciences; 1874 head of Real School	Real School m
Robert Spiller(† abt. 1913 Maribor)	1876-1897-	Real School p
Gaston knight Britto ²⁴⁵⁸	11/9/1874-31/5/1900	Real School m, p
Gustav Knobloch ²⁴⁵⁹	11/9/1874-1907	Real School m , descriptive geometry
Josef Frank ²⁴⁶⁰	1878-1895	Real School p , headmaster and boss head of professor's library
Luka Lavtar	1875-1915	Teachers' preparation College m
Alfonz Müllner (1840 Velikovec-1918 Vienna)	-1879-	Teachers' preparation College, Natural Historian, later custodian of Museum in Ljubljana
Heinrich knight Jettmar (* 1849 Lvov)	1879-1883	Gymnasium p
Franz Horak (Horák)	-1879-1882-	Gymnasium p
Jakob Hirschler (* 1852 Bratislava) ²⁴⁶¹	1880-1897	Gymnasium p, m
Karl Zahlbrucker (* 1858 Bratislava; † 7/11/1931 Maribor)	1897-	Gymnasium p, m

²⁴⁵⁴ Marburger Zeitung, 13 (1874), 48, April 22, p. 1; Anton Šantel, Zgodbe moje pokrajine, Ljubljana 2006, p. 157, 159; Andrej Vovko, Gimnazijska leta dr. Pavla Turnerja. Studia Historica Slovenica, 1 (2001), 1, p. 40.

²⁴⁵⁵ Tagesbote für Untersteiermark Organ der liberalen Partei, 9 (1870), 159, October 20, p. 2.

²⁴⁵⁶ Hartman, ibidem 2001, p. 800.

²⁴⁵⁷ Z. öst. Gym., 22 (1871), p. 639.

²⁴⁵⁸ Z. öst. Gym., 25 (1874), p. 587, 637; Slovenec, 28 (1900), 124, May 31, p.4.

²⁴⁵⁹ Hartman, ibidem 2001, pp. 500-501, 518, 523-525, 531, 539, 542, 569, 597, 647-648, 768-769, 781, 798.

²⁴⁶⁰ Bruno Hartman, Knjižnica mariborske realke (realne Gimnazije) (1870-1941). Časopis za zgodovino in narodopisje, 56 (1985), 2, p. 144; Z. öst. Gym., 21 (1870), p. 488; Verordnungsblatt für den Dienstbereich des K. K. Ministeriums für Kultus und Unterricht. Wien, (1869), pp. 140, 154; <http://www.pgmb.si/zgodovina-prve-gimnazije-maribor/> consulted on February 28, 2013.

²⁴⁶¹ Slovenski gospodar, 15 (1881), 7, February 17, and 16 (1882), 20, July 27; Etbin Bojc, Šole in učiteljstvo na slovenskem Štajerskem pred sto leti (prispevek za šolsko zgodovino ob 200-letnici terezijanskih šol). Časopis za zgodovino in narodopisje, 42 (1971), 7, pp. 115-118.

Styria and compared it to Postojnska Jama.²⁴⁶² On January 20, 1877, when Tesla was still in Graz, Reibenschuh experimented in Graz in front of the Styrian Naturalists Society to explain the theory of flame according to ideas of Edward Frankland (* 1825; † 1899), several years after Pöschl discussed the similar singing flame in front of the same Styrian Naturalists Society. Reibenschuh described Davy's safety lamp, and Karl Knapp's experiments with gases published in *Chemisches Centralblatt* in 1870 on page 386. Knapp's experiments were advanced by the Privatdocent of chemistry of Polytechnicum in Darmstadt Karl Heumann (* 1850 Darmstadt; † 1894 Zürich) under the title *Zur Theorie leuchtender Flammen* in several journals including the most important ones²⁴⁶³.

18.5.10 Maribor Telephones

Besides good school laboratories and teaching stuff Maribor was able to show to the newcomer Tesla quite a developing technology. After his Prague studies Tesla in Budapest worked for a local telephone company of Ferenc Puskás (* 1848; † 1884) and his brother Tivadar Puskás (* 1844; † 1893) established in Pest part of Budapest on May 1, 1881. Among others Tesla installed the first telephone for company Ganz & co. (*Ganz vállalatok*) which later supported Tesla's AC motors.²⁴⁶⁴ Did Tesla work on telephones also in Maribor in 1878/79 while the electric communications began spreading to Slovenian lands? In 1847 Maribor got a greater telegraph station for state and military purposes while the public use of Maribor telegraph was possible after the year 1850. On December 10, 1877 they tried the first telephonic debate between the main stations in Graz, Klagenfurt and Maribor²⁴⁶⁵ through the existing telegraph connections. Whatever was said on one side was heard on the

other, and in Maribor they were able to hear the talking between Graz and Klagenfurt.²⁴⁶⁶

On 6. 12. 1877 the professors of Real School of Ljubljana used their recently acquired telephone for a successful experiment in the office of the Carniolan Land Hauptmann Bohuslav Ritter von Widmann (1836 Olomouc-1911) with reports immediately published in *Laibacher Zeitung*.

On January 14, 1882 Ljubljana clockmaker and electro-mechanic Josip Geba (* 1854) began Ljubljana telephony. Josip and Anton Geba (* 1860; † after 1901) were the sons of Marija (* 1818) and the co-owner of city barracks Franz Geba (Fran, * 1823; † after 1881). Josip used Siemens' system with a trumpet to get a telephonic connection through the telegraphic cable between the fireman's watch on the tower of Ljubljana Castle and the rooms of Ljubljana Fireman's Society designed to speed up the response time. On 14. 1. 1882, the Narodna Čitalnica member Geba installed the first firemen telephone line in Ljubljana. In Ljubljana High Real School, Josip Geba presented his instruments including Hughes²⁴⁶⁷ microphone. In 1881, Albert Samassa (1808-1883) and his son Albert Samassa (1833-1917) used Geba's system to connect their office in villa on the southern slopes of Castle Hill above Karlovška Street with their foundry casting bells and cannons further south on Dolenjska Street of Ljubljana by 140 m long telephone line.²⁴⁶⁸ Geba used two Siemens' telephones: Dr. Böttcher's (Karl Böttcher) and Bell's designs. In 1893 Karl Böttcher reported on his designs at Chicago fair where he met Tesla. Geba also used two converters: one of Emil Berliner (* 1851; † 1929) from Bell's enterprise in Boston and Siemens'

²⁴⁶⁶ Velimir Sokol, *Stogodišnjica telefonije u Hrvatskoj*, Zagreb 1981, p. 174; *Narodne novine* (Zagreb), December 20, 1877, p. 291.

²⁴⁶⁷ On April 27, 1867 Pöschl reported on Writing telegraph of David Edward Hughes (* 1831 London; † 1900) to the Styrian Naturalists Society. In between he wrote and tried several telegraphs (Jakob Pöschl, *Über den neuesten Typendruck-Telegrafen von Hughes*, *Mitt.nat.Ver.Steier.*, 5 (1868), 31, p. XXXI; Simon Šubic, *Telegrafija, zgodovina njena in današnji stan*, *Letopis slovenske matice* (1875), pp. 31-35).

²⁴⁶⁸ Žarko Lazarević, *Začetki uvajanja telefonije v Ljubljani*, *Kronika* (Ljubljana), 35 (1987), 1-2, p. 97; *Slovenski Narod*, (1882), 16, January 20; *Slovenski narod*, 14 (1881), 223, September 1; *Laibacher Zeitung*, (1881), September 22, and (1882), March 16; *Laibacher Wochenblatt*, (1882), February 28; Primož Kuret, *Mahler in Laibach*, Ljubljana 1881-1882, Wien 2001.

²⁴⁶² Reibenschuh, 1868, XXXV; Franz Anton Reibenschuh, *Die Grotte bei Sachsenfeld*, *Mitt.nat.Ver.Steier.*, 5 (1868), p. 76.

²⁴⁶³ Karl Heumann. *Ber. d. Dt. Chem. Ges.* 8, 1875, *Dinglers Polytechnisches Journal* 1875, 217: 199–207, and *Liebigs Ann.* 1876: 181-184.

²⁴⁶⁴ Kulišić, *ibidem* 1936, p. 17.

²⁴⁶⁵ Studen, 2010, 50-51; Franc Rozman, *Socialistično delavsko gibanje na slovenskem Štajerskem*, Maribor 1979, p. 19; Leskovec, 1998, p. 121.

apparatus. On first floor of Židovska steza No. 3 (earlier City no 307) of Ljubljana downtown Geba opened the clockmaker enterprise in 1877 and become a member of Ljubljana Sokol society tightly connected with Prague liberal Sokol and the Sokol of Tesla's teachers in Rakovac. The treasurer Geba and deputy chief Srečko Nollı attended the meeting on 20th anniversary of Sokol in Prague on 18. 6. 1882 as well as in 1884. The South Sokol was established in Ljubljana in 1863 and re-established as the Gymnastic society Sokol in Ljubljana in 1868 with their own monthly. In 1882-1892 Geba also used the enterprise in Slonova (Elephant's) Street No. 11 in Lukman's house of Ljubljana to sell his clocks and electromagnetic telegraphs until Franc Čuden († 1912) took it over.²⁴⁶⁹ In 1887 he designed telegraph and lighting lightning rods for Dežman's Land museum Rudolfinum in Ljubljana while for Rijeka theatre he did the same in 1884. His son Dr. Josef Geba (* 21 February 1882) finished grammar school in Ljubljana on 4-12 July 1901 as a classmate of his friend Pavel Grošelj, studied philosophy in Graz as a member of Styrian Natural Science Society in 1908 to become director of library of the Viennese patent office (Österreichisches Patentamt Wien).

However, the experts of Geba's level were not yet frequent among Maribor's Tesla employers in Tesla's time. In 1892 the longest European telephone connection Vienna-Graz-Maribor-Celje-Ljubljana-Trieste was established along the south railway tracks and began its operation on October 1, 1892. The connection was a direct one which meant that all cities nearby did not get their telephones, in fact no place between Graz and Trieste was linked. That line was a pride of Habsburg state with its 505 km of total distance covered.²⁴⁷⁰

Already during his studies in Pöschl's class in Graz Tesla was acquainted with the telephone of Alexander Graham Bell, and on the end of Tesla's Graz studies description of telephone of the self-taught Philipp Reis presented in a lecture before the Physical Society of Frankfurt on 26 October

1861. As Tesla, Philipp Reis believed that the electricity could be propagated wirelessly through space like light, without an artificial conductor. Reis performed some experiments for his paper "On the Radiation of Electricity" in 1859, but the professor Pogendorff refused to publish it in *Ann.Phys.* which enabled the USA inventors to claim their priorities. Pöschl continued his presentation with induction telephone of Graham Bell which Pöschl illustrated with the nice illuminating experiments. Pöschl concluded his paper with experimental use of two pairs of telephones.²⁴⁷¹ He certainly accomplished similar experiments in Tesla's class soon after Carniolan Simon Šubic of Graz University seriously questioned the future of telephones in 1875 just before Bell's ground-breaking patent.²⁴⁷²

In 1875 before Bell's patent, Simon Šubic doubted the future of the novelty: "The phone cannot do more than repeating the orders of sounds or rhythm and cannot telegraph neither singing nor music."

18.5.11 Lower Styrian Members of Naturalists Society

The erudite Maribor guys of Tesla's days were closely connected with the Styrian Natural Science Society Naturwissenschaftlicher Verein für Steiermark., founded on 4. 4. 1862 in Graz;²⁴⁷³ S. Šubic used to be its member; then he stepped out because of hostilities of his colleague the chemist Leopold von Pebal (* 1826; † 1887). In 1871, the Society had 509 regular and 20 correspondent members. Among the correspondent members were Karl Dežman from 1870 until his death and the physicist Johann Prettnner (1812; † 1875). Prettnner was the director of the Klagenfurt factory and at the same time a researcher of the Carinthian climate which he described in the reports of the Society.²⁴⁷⁴

Between the years 1867-1870 Šubic was an ordinary member of Styrian Naturalists Society

²⁴⁶⁹ SI_LJU, Prosti obrti, Cod. XX-, No. 45; Laibacher Zeitung, No. 154 (1883), p. 1344; Vesna Bučič, Ljubljanski urarji v 19. in začetku 20. stoletja, Kronika (Ljubljana), 38/3 (1990), pp. 116-127.

²⁴⁷⁰ Lazarevič, ibidem, pp. 97-100; Sokol, ibidem, pp. 75, 81, 114.

²⁴⁷¹ Jakob Pöschl, 1879. Ueber das »Telephon«, Mitt.nat.Ver.Steier. Jahrg. 1878 (May 10, 1879), p. 41.

²⁴⁷² Šubic, ibidem, pp. 36-37.

²⁴⁷³ On the history of society by Ferdinand Graf in *Mitt. nat. Ver. Steier.* 1875, pp. I-XV. On establishing of society on p. II; *Mitt.nat.Ver.Steier.* 1870, LVIII

²⁴⁷⁴ *Mitt. nat. Ver. Steier.* 1873, pp. 1-15.

established in Graz on April 4, 1862,²⁴⁷⁵ but later he left the Society to save some money and because of his quarrels with his university colleague the chemist Leopold von Pebal (* 1826; † 1887). In 1871 the Styrian Naturalists Society had 509 ordinary members, and twenty corresponding members. Among the corresponding members were Karl Dežman between the year 1870 and his death, and the physicist Johann Prettner (* 1812; † 1875) who was the director of factory in Klagenfurt and researcher of meteorology in Carinthia which he described in Society's Journal.²⁴⁷⁶

After 1872 the ordinary member of Society was the Slovenian popular scientific writer Vinko Borštner, the professor of physics in Klagenfurt and later Plemelj's teacher in Ljubljana. Among the ordinary members were Šubic's colleagues from the physics chair of the University of Graz: Toepler joined the Society in 1869, Boltzmann was a member after 1871 with a pause in the years 1874-1876. Albert von Ettingshausen (* 1850; † 1932), a nephew of famous Viennese professor Andreas von Ettingshausen, became a member of the Society's board in 1877.

On May 27, 1871 Toepler became vice president of the Society, and he served on that post together with Pöschl in 1874. In 1880, after he left Graz, Toepler became the honorary member of the Society while his successor Boltzmann became the vice-president. In the beginning, Pöschl was the secretary of Society. In 1875 Pöschl became a member of board of Society, but he left the Society after he retired.

Only the ordinary members supported the work of Society with annual donations of 2 florins. The Society met with scientific lectures and experiments every month with a pause during summer holidays. The Society published a yearly report entitled *Mittheilungen der naturwissenschaftlichen Vereines* which was printed with a year of delay after 1874. A report included scientific papers, abstract of talks given on meetings, list of members, and list of journals accomplished by exchange with other similar Societies. After 1871 they got Rad JAZU of

Zagreb among others, but they did not receive the reports of Carniolan Museum Society.

Most scientific papers published in reports of Society discussed biology. Until 1875 they published two papers on physics by Graz University professors Boltzmann and astrophysicist Karl Friesach (* 1821; † 1891), one astronomical, eight meteorological, and nine mathematical papers.²⁴⁷⁷

Each of early Society's reports was concluded with local meteorological data similar as the Reports of Carniolan Museum Society. Tesla's professor Pöschl and Graz engineer Marek gathered meteorological observations from all over Styria and published the results of eleven and later of ten measuring points for Styrian Naturalistic Society in 1865 and 1867. Their Lower Styrian reporters were the professor Josef Essl of Maribor after June 1, 1863, and Anton Emil Reithammer from Ptuj. Ivan Kastelic reported about the weather in Lisca (Leisberg) Hill by Celje and in Celje with a help of Konrad Pasch. They used the barometrical data of the teacher of technique Eulogius Dirmhirn (* 1823 Schärding; † 1887). In Lisca and in Ptuj they did not use the barometer or psychrometer. The former Benedictine Dirmhirn studied technique in Vienna and after the Spring of Nations he became the official of Celje telegraph station. In 1854 he passed the technical examinations which enabled him to teach and finally to work as a schoolmaster of the new Provincial Civic School in Celje between the years 1870-1884.²⁴⁷⁸

The physician trained for treating patients at pools and spa facilities the palaeontologist dr. Emanuel Bunzel (* 1828 Prague) became the Viennese physician in 1881. He and H.W. Kern reported on weather circumstances in Rimske Toplice spa by Laško after July 1864. In 1866 Bunzel published a book about the guests of Rimske Toplice spa and on May 30, 1871 he became famous with the research of the parts of dinosaurs' skull in the coal mine near Wiener (Viennese) Neustadt.

Kastelic, Essl, and Reithammer also independently reported to the Society about their local meteorological data on December 27, 1862, July 25, 1863, and February 27, 1864. It was a part of

²⁴⁷⁵ On history and foundation of the Society see Ferdinand Graf in *Mitt.nat.Ver.Steier.*, (1875), pp. I-XV, and *Mitt.nat.Ver.Steier.*, (1870), p. LVIII.

²⁴⁷⁶ *Mitt.nat.Ver.Steier.*, (1873), pp. 1-15.

²⁴⁷⁷ *Mitt.nat.Ver.Steier.*, (1875), p. XV.

²⁴⁷⁸ *Deutsche Wacht*, 12 (1887), 68, August 25, p. 4.

their reports for the Viennese Central Office²⁴⁷⁹ which also gathered the reports of Karl Dežman and later of his sister Serafina's on Ljubljana data. On December 10, 1865 Reithammer presented to the Society a paper on ozone, and he described the Ball Lightnings near Franciscans' Monastery of Ptuj which disturbed him on September 6, 1866.²⁴⁸⁰

In 1865 Marek and Pöschl added the measurements of Jožef Rathberger of Laško and concluded their report with the comparison of meteorological data in the years 1863-1865, as well as notices on earthquakes, and about the hail which damaged vineyards of Slovenska Bistrica on July 12, 1865.²⁴⁸¹

Verzeichniss der Beobachtungs-Stationen im Jahre 1865.

Name	Länge von Fern	Breite	Sechse in Nr. Pau	Beobachtungs-staten			Beobachter
				Mrz.	Mitl.	Lk.	
Steinberg bei Alt-Aussees	31° 24'	47° 39'	2987	8	2	8	Josef Edler von Roithberg.
Markt Aussee	31° 26'	47° 37'	2077	7	2	7	Dr. Eduard Pohl.
Admont	32° 8'	47° 35'	2108	7	1	9	Clemens Vogl.
Graz	33° 8'	47° 4'	1173	7	2	10	Andreas Rospini.
Gleichenberg	33° 34'	46° 53'	898	7	2	9	Dr. Franz Frank.
Marburg	33° 22'	46° 54'	829	8	2	6	J. Essl.
Pettau	33° 32'	46° 25'	672	7	2	10	E. Reithammer.
Cilli	32° 58'	46° 14'	741	7	2	9	Conrad Pasch.
Leisberg bei Cilli	32° 56'	46° 14'	1222	6	1	9	J. Castellix s.
Markt Tuffer	—	—	—	—	—	—	Jon. Rathberger.

Anmerkungen.

1. Aus Steinberg bei Alt-Aussees wurden seit September 1865 keine Beobachtungen mitgetheilt.
2. In Aussee wurde der Regenmesser nur in den Monaten Mai bis incl. November in Anwendung gebracht.
3. Im Stifte Admont mussten die Beobachtungen in Folge des verheerenden Brandes Ende April 1865 abgebrochen werden; dieselben wurden jedoch mit 1. Jänner 1866 wieder aufgenommen.
4. In Pettau begannen die Beobachtungen mit dem Barometer und Psychrometer am 1. Februar 1865.
5. Auf dem Leisberg bei Cilli wurden die Beobachtungen vom Mai bis incl. October 1865 von Herrn Joh. Castellix sen. angestellt. In den übrigen Monaten beobachtete derselbe gemeinschaftlich mit Herrn Conrad Pasch in der Station Cilli, gleichwie im verlossenen Jahre.

Figure 18-52: First page of Marek and Pöschl report for year 1865 with observations from Slovenians from Styria²⁴⁸²

²⁴⁷⁹ Mitt.nat.Ver.Steier., (1863), pp. 5-6, 43; (1864), pp. 27, 41, 174; (1868), pp. 13, 16.

²⁴⁸⁰ Anton Emil Reithammer, Ueber den Ozongehalt der atmosphärischen Luft, Mitt.nat.Ver.Steier., (1867), pp. 76-80; Anton Emil Reithammer, Feuerkugel am 6. September 1866 in Pettau, Zeitschrift der österreichischen Gesellschaft für Meteorologie, (1866), p. 250.

²⁴⁸¹ Bernhard Marek, Jakob Pöschl, Jahres-Uebersicht der meteorologischen Verhältnisse von Steiermark. Nach der Angaben von 11 Beobachtungs-Stationen zusammengestellt, Mitt.nat.Ver.Steier., IV. für 1865 (1867), pp. 124, 149-150.

²⁴⁸² Marek, Pöschl, 1867, 124.

The student Tesla was probably not admitted to the sessions of Styrian Naturalistic Society, but he certainly heard a lot about them in his classrooms and in debates with his professors and classmates. Albert von Ettingshausen later became a fan of Tesla, and Albert von Ettingshausen's lectures in front of Styrian Naturalistic Society natural society on induction were certainly Tesla's favourite. Even before Tesla matriculated in Graz, Tesla knew a lot about the motor of Charles Grafton Page (* 1812; † 1868 Washington D.C.) designed in late 1830s and up to 1851. Simon Šubic and Tesla's teacher Sekulić acquired Page's motor already for their lab in Hungary, while the professor Niccolò Vlahović got Page's motor for the lab of Grammar School of Koper before 1864.²⁴⁸³

Dušan Mrkić (Dan Mrkich, * 1939; † 2005 Canada) was Rakovac High Real School alumni and lived in former Tesla's provisional home in Karlovac house of Tesla's uncle for a year before he followed Tesla's footsteps through Europe including Maribor. By Dan Mrkić's and Tesla's friend Kulišić's report Tesla worked as technical designer for Maribor master Druško, the draftsman with a Tool and Die machine shop. Tesla lived illegally in Tegetthofstrasse before the policemen arrested him down there. Mrkić's Maribor informer was Momčilo Radić who knew about Kulišić's report.²⁴⁸⁴

Tesla disliked drawing during his student years in Rakovac but later he obviously changed his mind when he settled down in Maribor in winter 1878/1879. Tesla needed money, so drawing was as good as any other job. For his supposed work in technical office of the industrial engineer Druško, Tesla allegedly earned 60 forints per month and additional salaries for successful work with which he at least doubled his former Graz student incomes. The principal actor of Maribor theatre had lower income in those times²⁴⁸⁵ which could mean that Tesla tried to better his real position in the eyes of his friend Kosta Kulišić because Tesla wished to hide his own humiliating whereabouts. It seems that the young Nikola liked to gamble and drink in Maribor which was the reason why he

²⁴⁸³ Sabaz-Deranja, 1994/95.

²⁴⁸⁴ Mrkić, ibidem, pp. 35-38; Kulišić, ibidem 1936, p. 14; Pištalo, ibidem 2012, p. 82; Momčilo Radić, Nikola Tesla ustvarjalna pot izumitelja. Ob 135 letnici rojstva, Maribor 1992, p. 108.

²⁴⁸⁵ Hartman, ibidem 2009, p. 229.

never fully explained that period of his life. Who was master Druško whom Tesla praised to his former rummy Kosta? He could have been Druškovič, Drušković or Druscovich because all

those three forms of family name are still available in the state of Slovenia although they aren't frequent.

Table 18-8: Important lectures and discussions of professors of physics at Polytechnics and at the University of Graz were published in full or summarized in the reports of the Styrian Natural Science Society; among the listed ones, only Mach was not a member of the Society.

Author	Date and page of the publication in the Reports	Thematics	Lecture or published Paper
Mach	28. 10. 1865, 1867: XXXII–XXXIV	Plateau's experiments with difficultly soluble liquids (schwerlösliche Flüssigkeiten) and the nature of the molecular forces	P
Mach	23. 2. 1867 1868: XXXI	Helmholtz' Vibrational Microscope	P
Schwarz	23. 2. 1867, 1868: XXXI	Johnson & Mathey's London melting of Platinum established by Percival Norton Johnson (1792–1866) and a stockbroker George Matthey (1786–1853 Rosemount in Sussex) in 1851	P
Toepler	29. 1. 1870	Induced Electrics and Siemens' Dynamo from 1870	P
Toepler	1872, 64–116	Physical interpretation of representation by power series	R
Ettingshausen	1873	Phosphorescence and fluorescence	P
Toepler	1873	Aurora Borealis	P
Boltzmann	1873, 25–36	About Maxwell's Theory of Electricity	R
Toepler	10. 4. 1875 XLIX–LI	Capillarity	P
Ettingshausen	1877/1878, 46–51	Magnetic phenomena in Graz in 1877	R
Ettingshausen	12. 5. 1877/1878, 46–51	Electrodynamic-electromagnetic rotation, Page's motor	P
Boltzmann	17. 11. 1877/1878, LI–LII	Current state of mechanical theory of heat, experiments of Stefan and Loschmidt	P
Boltzmann	28. 12. 1878, XVII, LXIX–LXX	Physical theory of pitch and color with the use of Fourier's analysis	P
Ettingshausen	1878	Electric induction	R

Table 18-9: Members of the Styrian natural science Society (association) connected with Slovenes

Name	Volumes and pages of notes in the Reports	Places and jobs
Karl Dežman	1870, XLVI, associate member	Ljubljana, curator
Ivan Prettnar	1870, XLVI, associate member	Celovec (Klagenfurt), manufacturer

Jožef D. Bancalari	1882, III	Maribor, pharmacist, director of the town savings bank, cyclist, mayor in 1867-1870, member of Schlarafia Marpurgia ²⁴⁸⁶
Jožef Birnbacher	1882, III	Maribor, financial councilor
Vincent Borštner	1873; 1882, III	Celovec (Klagenfurt), Grammar school professor
dr. Emanuel Bunzel (Bunzl)	1870, XLVIII	Rimske Toplice, spa physician
Friedrich Byloff	1875, 1882, IV, 1885	c. Engineer, son of a Celje city engineer who planned a bridge over Savinja, 1824-1826
Barthilomäus knight Careneri	1882, IV	Castle Wildhaus above Selnica ob Dravi, huge landowner, Member of the National Assembly
Anton Elschnig (Elšnik)	1870, XLIX	Maribor, professor of the higher real school, Zoologist Botanist
Edvard Ferlinz (* 1817; † 1874)	1863, 12; 1870, XLIX	Maribor, Bookshop
Karl Fontaine von Felsenbrunn	1865, 3	Ljubljana, senior financial adviser, colonel, writer of the Carinthian tax manual in 1866
Karl von Formacher	1882, V	Slovenska Bistrica, landowner
Grammar school	1870, L	Celje
Karl Hauser	1870, LI, 1882, VI	Maribor, head procurator
Jožef Heinisch	1882, VI	Oberhaag /Osek, Headmaster
Jožef Huber	1870, LI	Celje, priest, gymnasium professor of mathematics and physics 1860- 1874, made inventory of coal available in the vicinity ²⁴⁸⁷
Heinrich Kalmann	1882, VII	Maribor, leader of the wine-growing school (Sadjarsko-vinarska) school; established in 1872
Ivan Kastelic	1870, XLVIII	Celje, court associate (judicial adjunct)
Ignac Klemenčič	1882, VIII	Graz, docent
Klöpfer	1882, VIII	Eibiswald/Ivnik, practicing physician
Jožef Koczbek	1870, LII	Radgona, doctor of physics
Magister farmacije Wenzel König (Venčeslav, * 1836; † 1901)	1882, VIII	Maribor, pharmacist, provided a guide for the pilot of aircrafts at the Parisian exhibition in 1877, member of Schlarafia Marpurgia ²⁴⁸⁸
Franc Krause	1870, LII	Ptuj, railway physician
Ferdinand Lippich	1870, LIII	Graz, professor of Polytechnics
Jožef Kupferschmied	1882, VIII	Celje, pharmacist
Aleksander Mell (* 1850 Prague; † 1931 Vienna)	1882, IX	Maribor, professor of teachers' preparatory and writer, studied natural sciences in Graz, since 1886 he led the Vienna Institute for the Blind
Franc Močnik	1870, LIV	Graz school counsellor
Dr. Karl Julius Potpeschnigg	1870, LV	Feldbach/Vrbna, District Commissioner, in 1882 in Graz
Julius Pfrimer	1882, XI	wine merchant, cashier of the Philharmonic Society and German politician ²⁴⁸⁹
Dr. Florian Puschtrauser	1882, XI	Hrastnik, department physician
Matej Reiser	1895, 1896	Maribor mayor
Anton Emil Reithammer	1870, LV	Ptuj, pharmacist

²⁴⁸⁶ Podgoršek, 2006, 365; Pertl, 1991, 580; Hartman, 2009, 166, 187; Hartman, 2001, 626.

²⁴⁸⁷ Orožen, 1974, 203.

²⁴⁸⁸ www.pokarh-mb.si/fileadmin/www.pokarh-mb.si/pdf_datoteke/vodnik2010/Redakcija_vodnik-celota_PAGES_0971-1068.pdf, pp. 999–1000 Retrieved on 4. 3. 2013; Pertl, 1991, 581; Hartman, 2009, 161

²⁴⁸⁹ Hartman, 2009, 26, 194.

Emanuel Riedl	1882, XII	Celje, senior Mining Commissioner
Rudolf Sadnik	1882, XII	Ptuj, sanitary assistant
Karl Schaumburg	1870, LVI	Ljubljana, construction councilor
Dr. Max Jožef Schüller	1870, LVI	Rohitsch/Rogatec, Imperial councilor, director
Konrad Seidl (* 1830; † 1879)	1870, LVI	Maribor, Member of the Viennese parliament for the Maribor district in the years 1870-1873
Dr. Janko Sernek (* 1834; † 1909)	1882, XIII	Maribor, the founder of the Slovene Reading Room, lawyer
Simon Šubic	1870, LVIII	Graz, university professor
Sigmund Vaczulik	1870, LVIII	Windisch Landsberg / Podčetrtek, pharmacist
Gundaker Count Wurmbrand	1882, XV	Ankenstein / Borl Castle, Captain, chamberlain member of the National Assembly in winter of 1878/1879; state minister in 1893-1895

Anton Druskowitsch of Maribor was probably not a right guy as he was a manufacturer in Livada No. 11 on left bank of Drava River outside the city of Maribor of those days. The shoemaker Josef Družkovič in Koroška Street No. 12 in those days 3rd Maribor quart on left bank of Drava was more promising candidate because several years after Tesla's departure he was noted among other Maribor manufacturers in 1884,²⁴⁹⁰ but Josef Družkovič was not officially registered during Tesla's Maribor months which sounds nice because the illegally employed worker Tesla most likely worked for the firm which was by itself also not legally registered yet.

Forty years earlier Josef Družkovič's house in Koroška Street No. 12 belonged to the painter Vincenz Lubiz but several shoemakers worked in the neighbourhood in Koroška Street No. 7 house possessed by his relative shoemaker Lubiz. In Koroška Street No. 1 there was a nice new house of shoemaker Klementsčitsch (Klemenčič). Somewhat further there were several good situated owners: the district surgeon Josef Förderek owned the house in Koroška Street No. 25 and producer of flower-liquors Jakob Felber owned Koroška Street No. 35 and No. 36 which was extremely elegant with eight windows on the front. The house in Koroška Street No. 12 hosted the city fireman after 1892, but the numbers of houses eventually slightly changed from Puff to Curk's times so that Puff's house of miller Senekowitsch (Senekovič) or his widow Jožefa in Koroška Street No. 20

²⁴⁹⁰ Josefine Jurik, Jurik's Adress-buch der Stadt Marburg: mit einem ausführlichen Wohnungs-Anzeiger, Schematismus der Behörden, des Handels-, Fabriks- und Gewerbewesens und geschichtlichen, topografischen und statistischen Daten, Maribor 1884.

became Koroška No. 13 and later Vojašniška Square No. 7.²⁴⁹¹

Josef Družkovič was later noted as owner of house in Tržaška Street No. 65 in Maribor in the times when Koroška Street No. 12 was already the fire station. Certainly, a very promising guy as Tesla's onetime boss. What else could we say about Josef Družkovič (Družkovič), especially about the size of his manufacture and the number of employees with Tesla illegally included?

18.5.12 Maribor Opportunities

Tesla certainly had many opportunities in quickly developing Lower Styria after the abolition of guilds in 1859. Kager's metallic enterprise and foundry began to operate in 1737 and a century later it used motor supply in a modern works in 1889.²⁴⁹² The girdler and silversmith Kager was one of the predecessors of Maribor foundry. In 1868 Denzl's (Dencel) established bell-foundry which produced Maribor industrial tradition²⁴⁹³ as did Heriček's pottery. Heriček introduced gas motors. After they proved to be too expensive, he introduced Sinkovič's oil motors in early 20th century. Milko Sinkovič was probably from Split. Sinkovič also produced electromotors before First World War because the use of electrical energy increased after Frohm's Smithy developed into an

²⁴⁹¹ Rudolf Gustav Puff, Jože Curk, Maribor: njegova okolica, prebivalci in zgodovina, Maribor 1999, pp. 83-84, 355, 356.

²⁴⁹² Podgoršek, ibidem, p. 366; Franjo Baš, Mariborske slike, Maribor 1934, p. 34.

²⁴⁹³ Bell-foundry and smelting-plant of Mr. Janez Dencel and sons in Maribor advertised in Slovenski gospodar, 13 (1879), 44, October 30, and 13 (1879), December 25.

industrial foundry in the late 19th century. By using the new railway, the manufacturers did not settle in singular production but established branches producing unrelated subjects. Therefore, Frohm besides foundry also managed oil factory, distillation, vinegar works, liquors, and vine-shop.

Johann Pengg's bell-foundry inherited Dencl's (Johann Denzl) and later Bühl's bell-foundry and smelting-plant on Meljska Street near the harbour of Drava River. After 1902 in the same neighbourhood fabric of machines and iron-foundry on motored power of Anton Bendl from Graz worked until Karl Ježek (1851 Blansko-1919) and his brother Richard Ježek (1860 Blansko-1948) from Blansko in Moravia bought it (1908-1910) as one of the rare strong Slavic-owned enterprises in predominantly German businesses of Maribor.

<i>Tscheligi Franz</i> <i>Expulsion aus der Stadt Maribor</i>	1890, 2165	1891
<i>Toxichij Josif</i> <i>Offenlegung des Geschäftsbüchchens</i>	2110	01.09.79
<i>Tesla Nikolaus</i> <i>Expulsion aus der Stadt Maribor</i>	2160, 2675	2160
<i>Tiegelkopfstanze</i> <i>Offenlegung des Geschäftsbüchchens</i>	2215, 4010, 10109	2215

Figure 18-53: Tesla's expulsion from Maribor under the numbers 2160 and 2675²⁴⁹⁴

Tesla was not the only one who found the industrial future of Maribor appealing, although Tesla might have been the poorest of those inventive guys. Franz Swaty was few months Tesla's younger technological chemist. He was raised in a family of construction engineers from of Lower Austria, Vienna and Mainz. Swaty and Tesla had similar education although Tesla did not finish his chemical technology studies in Graz.²⁴⁹⁵

²⁴⁹⁴ SI_PAM/0005, fond of City mayordom of Maribor (Mestne občine Maribor), (book) K 22 – Index 1879 (General registrar (splošna registratura)).

²⁴⁹⁵ Leskovec, 1991, 345, 347; Baš, 1934, 33; Kralj, Analina; Kralj, Davorin. 2015. *Franz Swaty in umetnost brušenja v Mariboru*. Maribor: Pivec, 2015, 17, 19, 30-31, 35; Wien, rk. Erzdiözese (östl. Niederösterreich und Wien), 18th Bezirk Waehring Sterbebuch, 03-13, page 127, note 4; Wien, rk. Erzdiözese (östl. Niederösterreich und Wien), Fischamend,

During Tesla's Maribor challenges, the hones, grinding wheels and tools factory Swaty was established by the technical chemist Franz Swaty (* 1855) and his father construction engineer of the same name Franz Swaty (* 1826) in Vienna in 1879. At least two decades earlier, the Swaty's firm was already registered in Vienna because Franz Swaty (* 1826) and his father were both the Viennese city magistrate construction engineers and in that capacity holders of the Viennese registered business just with the right of the engineer authorized and sworn by the Habsburg state authorities in their domestic flat in Vienna. They used that opportunity for different engineering tasks in the area, but they switched into the hones and grinding business only after Franz Swaty (* 1855) finished his studies of the applicative technical chemistry with fresh modern ideas which immediately proved to sell very well after their prizes won at the fairs all around Central Europe including Maribor.



Figure 18-54: Title page of the business protocol of the Maribor authorities²⁴⁹⁶

Taufbuch, 01-05, pages 87 and 110, note 2; Wien, rk. Erzdiözese (östl. Niederösterreich und Wien) 04., Wieden Taufbuch. 01-20, page 412; Wien, rk. Erzdiözese (östl. Niederösterreich und Wien), 01., Am Hof, Trauungsbuch, 02-06 page 124; Adolph Lehmann's allgemeiner Wohnungs-Anzeig 1859 pp. 785 middle row, 834; 1860: 151 left; 1861: 316; 1864: page 414; 1865: 332; 1867: 323; 1868: 635; 1870: 442, 464; 1871: 408; 1872: 486, 508; 1873: 538; 1874: 537; 1875: 537; 1876: 529; 1877: 824; 1878: 879; 1879: 859, 1047; 1882: 1436; 1885: 1213, 1528; 1888: 1057, 1291, 1635; 1889: 1097; 1890: 1103; 1891: 1134; *Hof- und Staat...* Wien 1864: pp. 828, 1868: 184, 222, 224, 227, 241; 1874: 136, 1876: 553, 1878: 917, 1879: 896, 1880: 927, 1881: 927, 968, 1885: 220). Puff, Rudolf Gustav: *Marburg in Steiermark, seine Umgebung, Bewohner und Geschichte*, 1847.

²⁴⁹⁶ Ibidem, ledger 1879 (splošna registratura), notes on the cover of ledger.

Swaty's enterprise was among the oldest European producers of hones as the grinding tools. Initially, the production was based on Swaty's own patented procedure for production of hones, grinding tools and wheels in mineral bond. Franz Swaty and his son of the same name Franz Swaty (* 1826), whose own son was just few months older than Tesla, worked in Vienna as the construction engineer of the Viennese city magistrate builder department. After his father passed away, Franz Swaty (* 1855) indicated his father as the inventor which could mean that the initial patent of grinding was the work of Franz Swaty (* 1826) also because it was not quite far from constructions. Certainly, their grinding tools were patented as the work of chemical technology and Franz Swaty (* 1855) had a note on his Maribor tombstone verifying that he was an expert for chemical technology with no construction noted as his previous business. Franz Swaty (* 1855) therefore partly abandoned the construction tradition of this ancestors for the then modern applicative chemistry which recently excelled with Liebig's chemical agricultural fertilizations which Tesla highly praised after it penetrated in many other branches of technical needs including the grinding. Franz Swaty's (* 1826) son the technical chemist Franz (Francis) Swaty took over the Maribor factory of aluminium grindstones and hones for the sharpening of razors and additionally advertised Swaty's honing-oil for the protection of hones before and after grinding or shaving. Franz Swaty (* 1855) proudly stated that he is the only heir of his deceased father's factory in Maribor. That proves that Franz Swaty (1826-1888) established the Maribor enterprise designed for the successful production of hones based on the invention of Franz Swaty (* 1826) and not his son Franz Swaty (* 1855), probably because Franz Swaty (* 1855) was underaged up to 1882 according to Habsburg laws used in those times.

Before 1890, Franz Swaty left his native Vienna and moved to Maribor. He resettled at the latest after he was orphaned. Franz Swaty (* 1855) married Franziska Maria Wenedikter (Fanny, * 1863), who was probably the descendant of the former owner of the manor Kozjak nad Pesnico in Zgornja Kungota in the hills above Maribor on the north.

Besides mighty Swaty, Tesla had other opportunities in Maribor. The "Kovina-Metal"



Figure 18-55: Craft of Tesla's master Druško. He was probably a city shoemaker at Leitnerhofgasse no. 234 Josef Druschkovitsh (Družkovich, Družkovič), noted under the serial number 1125 on 17. 7. 1873 with no. 6504 in the craft register of the city of Maribor (SI_PAM / 0005, K 531 - Craft registers managed as based in craft legislation 1859-1907: register for free and handicraft crafts 1866-1883). Druschkovits's manufacture first worked illegally with Tesla illegally included. It was officially registered only after Tesla's expulsion.

enterprise in Tezno was also successful. In Maribor, they had a large glass factory, and in 1884 there were already thirteen engineers: superintendent Mauras Franzc, widow of the engineer Schnabel (Schnabl) named Theresa, Carl Arthlet, Byloff, J. Eger, F. Hallmann, Anton Heimann, Adelbert Markhl (Markl), Franz Nowak, J. Prodnigg (Prodnik), C. Rakoneli, Josef Swoboda, architect of the Maribor theater railway district engineer Adam Wiesinger.²⁴⁹⁷ Adam Wiesinger was in Maribor already before 1859. His construction of Maribor theatre began in 1848, paid by the large group of founders of the Maribor theatre. The plans were created by the railway engineers Adam Wiesinger and Gustav Lahn, while Janez Nussold took over the building work for 50,000 golden coins (*goldinars*). The stage equipment was supplied by the Maribor carpenter, hewer and mechanical engineer Anton Halleger. In front of the main façade of the new theatre building, on the location where a casino had been envisaged, there was access to the theatre café in an older building situated south-west of the theatre. The café and theatre were connected by a covered wooden walkway. In 1863 the building of café was

²⁴⁹⁷ Cverava, 2006, 40; Jurik, 1884.

demolished and in 1864 a casino was built on the initiative of the "Reading (Casino) and Social Society" in front of the main façade with today's address Slomškov trg No. 17. The Graz architect Johann Schöbl planed the works, whilst the building work was led by the Maribor town builder Josef Lobenwein and the building engineer Hugo Skale. Before Tesla's arrival between 1866 and 1870 the theatre building was renovated for the first time.

The son of Maribor magistrate secretary Aleksander Nagy (1834 Ptuj-1909 Maribor) came to Maribor only in 1881, therefore after Tesla's deportation. Nagy finished the Technical Hochschule. Slowly, the considerably perspective networks of engineers developed in Maribor although they remained in the shadow of Graz communities until the ancient land of Styria was split in Austrian and Yugoslavian part in 1918. That's why Puh, who used to be the very best self-taught inventor of all Styrian guys, preferred to concentrate his businesses in Graz.

In Tesla's times the engineer W. Fischer donated New-Year forint for poor fellows as did the author of Maribor telegraph-textbooks Johann Kral or the machine-operators Hartl and Franz Mayer.²⁴⁹⁸ In 1879, Johann Kral was a head of Bureau of Maribor Telegraph Station (k.k. Telegraphen-Aemter) in Maribor in Tesla's time.²⁴⁹⁹ Tesla certainly had a lot to learn from J. Kral, although the telegraph technology was finished to the extent which did not offer many chances for new discoveries of the young inventor like Tesla. In 1881 Johann Kral was still in Maribor, but in 1882 he was not listed anywhere in office in Habsburg monarchy. In 1883-1885, the holder of the great papal ordain Johann Kral headed the postal-telegraphic direction Ústí nad Labem (Aussig) situated in a mountainous district at the confluence of the Bilina and Laba (Elbe) rivers as a major industrial centre, river port, and important railway junction. In 1887-1889, J. Kral had the same duty in nearby České Budějovice (Budweis), in 1888-1889 also as the controller of post of the Viennese Post & Telegraph direction in the times when Richard Lischke was still not noted as important enough Maribor telegraph official in the official listings. In 1901-1902 Johann Král was High Post

Administrator (Ober-Post-Verwalter) of k.k. Aerarial-Post- und Post- und Telegraphenämter in Viennese First Brezirk Post- und Telegraphenamt no. 7 on Schottenring no. 16 and Börsegasse no. 8. In 1904, he served no more. In 1902-1903, Johann August Kral as Ober-Post-Verwalter and Amts-Vorstand lived in VII/2 Bezirk Neubau of Vienna in Kirchengasse no. 40. He was still there already as retired official in 1904. In 1905, Johann Kral lived no more and his supposed daughter the unmarried milliner (Modistin) Antonie Kral took over his flat in VII/2 Bezirk of Vienna in Kirchengasse no. 40. Johann Kral was not buried in any of the three churches of the 7th Viennese Bezirk in 1904 or 1905. His supposed son and publisher Ernest Kral used to be an adjunct of k.k. State Roads (Bahnen) and lived in the Viennese II/8 Bezirk in Borharienstrasse no. 144.²⁵⁰⁰

The expansion of Maribor industry in no way stooped with Swaty, Richard Lischke, and Kral's successes. In 1869, Maribor gas station was established and next year the modern gas lighters were used. Shortly after Tesla left Maribor, as the first in that part of Europe Karl Scherbaum used thirty-six incandescent lamps to lighten the city of Maribor in April 1883 several weeks before the Viennese Internationale Elektrische Ausstellung. In the same year, his Maribor steam engine mill used the first Wieghorst's Hamburg furnaces²⁵⁰¹ in Habsburg Austria and Scherbaum developed his branches in Maribor, in Fram, and in Bistrica. His mill in Bistrica had its own electric plant with turbines before the end of century. Gustav Scherbaum later joined the funny society *Schlarafia Marpurgia*.²⁵⁰² Several days after Scherbaum the locksmith-master Jožef Martini used electrical lamps in his showrooms on Vetrinjska Street in Maribor and prepared the similar ones for the merchant Jožef Martinz in Gosposka Street. There were some opportunities for Tesla in Maribor, but even the USA magnates

²⁵⁰⁰ *Hof- und Staat...* Wien, 1881: 247; 1882: 809; 1883: 95, 379; 1885: 423; 1887: 446; 1888: 441, 708; 1889: 441, 708; 1901: 427, 129; 1903: 440, 443; 1904: 284; *Adolph Lehmann's allgemeiner Wohnungs-Anzeiger* 1902 2: pp. 620/706; 1903 2: 636; 1904 2: 644-right; 1905 2: 681; 1906 2: 540-541; 1909 2: 607.

²⁵⁰¹ Patented in London on March 1, 1882.

(<http://www.ebooksread.com/authors-eng/great-britain-commissioners-of-patents/the-commissioners-of-patents-journal-aer/page-12-the-commissioners-of-patents-journal-aer.shtml> consulted on March 13, 2013.

²⁵⁰² Hartman, *ibidem* 2009, pp. 161, 187.

²⁴⁹⁸ *Marburger Zeitung*, 18 (1879), January 1, p. 5.

²⁴⁹⁹ *Marburger Zeitung*, 18 (1879), March 4, p. 3; *Hof- und Staat...* Wien 1879: pp. 438; 1881: 247.

were unable to back Tesla's Wardencllyffe Tower which was even further from Maribor possibilities.

18.5.13 Puh's Bicycles

Puh (Puch) was five years Tesla's younger and with no doubt one of the ablest industrialists in Styria of Tesla's times. Puh was more of Edison's sort because he never seriously thought about any academic positions or studies as he was able to advance without them.

In 1889 Puh's brother-in-law Franc Neger (* 1859; † 1944) from Bischofegg near Ivnik (Eibiswald) established a factory of bicycles and sewing machines in Maribor, but Janez Puh (Johann Puch, * 1862; † 1914) himself in spite of his locksmith schooling in Rotman near his native Juršinci-Oblaček (1874-February 21, 1877), and in Radgona (1877/78) preferred to run his bicycle factory in Graz in 1889 and 1899, although he liked to visit his lower-Styrian relatives.²⁵⁰³ In 1886 in Celje *Cillier Radfahrer Verein* was established and its competitor more Slovenian *Klub biciklistov* became a part of Celje *Sokol* Society. In 1898, the predominantly Slovenian railway workers founded *Delavski kolesarski klub* in Maribor.

In Tesla's times many flats were offered in »Houses of Southern Railway Colony workshops« near the train station of Studenci on the right bank of Drava River which developed into a prosperous suburb of Maribor. The Southern Railway Colony workshops were the biggest Maribor enterprise situated in Graz suburb where they hired over 1000 workers already upon their beginning in 1863, but Tesla or Druškovič were not among them.²⁵⁰⁴ Maribor had quickly expanding workers' suburbs which gave ideal opportunities to the semi-professional gamblers like Tesla. In September 1868 some modern revolutionary elements developed after the establishment of Educational Society under the leadership of Franz Wiesthaler (* 1825; † 1890) who became the editor of *Marburg Zeitung* next year and again between the years 1882-1887. He kept his liberal ideas of the

²⁵⁰³ Kristina Šamperl Purg, Oris nacionalne podobe tehniške inteligence v avstroogrski monarhiji ob prelomu stoletja na primeru Janeza Puha, Melikov zbornik. Ljubljana 2001, pp. 656-658.

²⁵⁰⁴ Rozman, ibidem, pp. 20, 27; SI_PAM/0973, Matične knjige delavcev 1860-1990.

Spring of Nations from the year 1848 alive and afloat, and he certainly did not support the United Slovenia movements which threatened to transform his Lower-Styrian Germans into minority.²⁵⁰⁵

18.5.14 Humiliating Arrest and Exile

Tesla could have worked for the small enterprises as were Dencl or Kager's, but Southern Railway workshops were also attractive near Tesla's favourite pub in Graz suburb²⁵⁰⁶ with their forty new workers' buildings housing 724 flats built in 1863 and 1868 on the right bank of Drava outside the Maribor Down Town. That was the biggest urbane complex in the Habsburg countries! The workers used their own kindergarten, school, store, and two pools.²⁵⁰⁷

Tesla was deported as a vagabond: he probably slept illegally in Maribor Graz suburb in one of 724 flats available there. As a declared vagabond Tesla certainly did not have a regular job and gained some extra money with gambling cards and billiard until one of his angry loosing companions denounced Tesla to the city authorities, if Murko or Tesla's father did not do that ugly job themselves. Maribor of those days and especially its Graz suburb was quickly filled with comparatively educated workers from the north which provided excellent opportunities for a versed gambler of blackjack or even tarock which was played among Bohemians, Austrians, and Slovenians but probably did not become that popular in Karlovac or Lika.

After Graz debacle Tesla spent his free hours playing cards and chess in Maribor pub By the Southern Railway (Pri Južni železnici, Zur Suedbahn, Zur Süd-bahn) as the pub was called during Habsburgian Monarchy. Only after the year 1919 the pub was called National pub (Narodna gostilna, vulgo *Veseli kmet*, *Pri Veselem Kmetu*, By Happy farmer). According to Kulišić the pub was also called »Tegetof« by its street name borrowed from Maribor-Born admiral Wilhelm

²⁵⁰⁵ Rozman, ibidem, pp. 29, 84-85; Hartman, ibidem 2001, pp. 594-595.

²⁵⁰⁶ In last three decades of Habsburg Monarchy the Magistrate of Maribor listed its manufacturers (Leskovec, ibidem 1991, 332).

²⁵⁰⁷ Sonja Ifko, Zgrade radionica Südbahn željeznica u Mariboru i njihov utjecaj na urbanistički razvoj grada, 5th Pro Torpedo Annual Conference 25 to 26 May in Rijeka, Croatia. Collection of Summaries, Rijeka 2012, pp. 66-67.

von Tegetthoff. The pub Zur Süd-bahn (Veseli Kmet) had another domestic name “Vlahovič” on the corner of modern Partizanska street no. 26 and Mlinska Street across the coffeehouse Jadran, later Jeklotehna. In 1985 the pub was destroyed to provide more room for the new bus station²⁵⁰⁸ which Tesla would never approve. The pub Zur Süd-bahn (Veseli kmet) was a little building near the bigger Vlahovič’s house with a store and pharmacy in the corner of Meljska and Partizanska Street no. 36. The other pub called Prlek was on Meljska Street the first building on the left side after you passed the railway bridge.

Kulišić used to be Tesla’s rummy in Graz from January to June 1876. In January 1879 Kulišić accidentally found Tesla in Zur Süd-bahn (Veseli kmet) pub while Kulišić was waiting for his return train from Maribor. In Maribor Kulišić tried in vain to get a job of lecturer of geography and Italian language in Merchants School of the Schoolmaster Peter Resch († after 1918), who posted the invitation in *Tagespost*. Resch tried to equip Maribor High Schools classrooms with gas lighters,²⁵⁰⁹ and later as the director of Public Merchant School in Bolzano and important author of law books agitated against duels in 1903.²⁵¹⁰ Resch paid Kulišić’s travel expenses and next morning accompanied him to the railway station. Because they were too early, both Resch and Kulišić, or Kulišić alone, went to the nearby pub Zur Süd-bahn (Veseli kmet) and met Tesla who was playing piquet cards with two other guys there. Peter Resch was later the director of Simon Šubic’s former Trade School (Handelschule) in Graz and Fachexaminator (Job-Examiner) of k.k. Prüfungs-commission of two-class Trade schools in Vienna in 1910. In the same year, Konstantin (Kosta) Kulišić was a professor in k.k. higher Grammar school of Ragusa (Dubrovnik) with Serbian-Croatian teaching language in 1910. In 1913 and on the end of WWI in 1918, Peter Resch was still Fachexaminator (Job-Examiner) of k.k.

²⁵⁰⁸ Mrkić, *ibidem*, pp. 35-36, 38; Kulišić, *ibidem* 1936, p. 14; Marinčić, *ibidem*, p. 40; Cverava, *ibidem*, p. 40; email of Primož Premzl Monday, July 9, 2018 3:44 PM.

²⁵⁰⁹ D. Mrkić, 2005. *Nikola Tesla*, Ottawa, p. 3; Marburger Zeitung, 15 (1876), 133, November 8; Kulišić, *ibidem* 1931, p. 10.

²⁵¹⁰ Peter Resch, *Das Moderne Kriegerrecht Der Civilisirten Staatenwelt*. Graz/Leipzig 1885; <http://forum.ahnenforschung.net/archive/index.php/t-19011.html> consulted on February 20, 2012.

Prüfungs-commission of two-class Trade schools in Vienna, but he was already retired.²⁵¹¹

In early March 1879 after prolonged search for lost Nikola, Tesla’s father Milutin Tesla (1819 Raduč-1879 Gospić) arrived in Maribor to convince his son to return home and continue his studies in Prague in autumn of 1879. Tesla refused although Milutin eventually even learned about Nikola’s fame in Nikola’s Maribor workplace.²⁵¹² The father Milutin or somebody else soon afterwards denounced Tesla to the city authorities. The coincidence of just few days which passed between the dialogue of Milutin and Nikola Tesla and Nikola’s arrest strongly suggests that Milutin asked the authorities of Maribor to bring his still underage son back to his school-home of Gospić. Milutin probably informed the Maribor guys where they could find his poor son Nikola.



Figure 18-56: Tesla gambling inn Zur Süd-bahn (Veseli kmet, Happy farmer) in Maribor

The police broke into Tegetthofstrasse of unknown number where the would-be inventor Nikola Tesla was living illegally. The poor fellow wasn’t registered at that address where he was living.²⁵¹³

In those times the mayor of Maribor was a nephew of the former mayor notary-lawyer decorated by the imperial Franz Josef’s medal Otmar Reiser (Othmar, 1792 Villingen in Schwarzwald-1868

²⁵¹¹ *Hof- und Staat...* Wien 1910: 487, 962; 1913: 504; 1918: 564; *Jahresbericht der Akademie für Handel und Industrie in Graz am Schlusse des Schuljahres ...; Jahresbericht der K.K. Handelsakademie (Staatliche Wirtschaftsoberschule) in Graz am Schlusse des Schuljahres...*

²⁵¹² Cverava, *ibidem*, p. 41.

²⁵¹³ Mrkić, *ibidem*, p. 36.

Maribor), the member of Styrian Naturalistic Society the notary Matej Reiser (Matevž, * 1830 Weilersbach in Baden; † 1895). Matej Reiser served as a mayor of Maribor between the years 1870-1882.²⁵¹⁴ He lived long enough to learn about Tesla's fame, but it is doubtful if Matej Reiser ever realised that the famous Tesla was just the same poor kid whom Matej Reiser expelled from Maribor with such a great aggressive haste. Matej Reiser's substitute mayor was a lawyer dr. Ferdinand Duchach (Duhač, † 1887), who later replaced the liberal notary Reiser on the post of mayor in Maribor. Duhač's replacement was an engineer Aleksander Nagy, who at least by education was nearer to Tesla's networks. During Tesla's time of troubles, the examiner of Maribor City bills was the district governor (Bezirk Hauptmann) of Maribor the German Julius Seeder who was also the citizen of honour of the manor (Orts Gemeinde) Hitzendorf west of Graz.²⁵¹⁵

In 1869 Maribor City Administration had twenty-nine employers together with the head of office, eight officials, sergeant major and eleven policemen with the manager of prison among them. In 1875 the Municipal Administration (Magistrate) was managed by mayor, his substitute, four city counsellors voted among the municipal advisers, the office head, eighteen officials and lower officials, lithographer, servant, and servant's help. In 1900 Maribor already had fifty-five policemen.²⁵¹⁶

After the year 1850 Maribor City Administration (Magistrate) also worked as the local political district. The officer of Maribor city authorities Oldrich Taube (Ulrih Golob, Glušec by the narration of the writer Praštalo) after the police accusation signed the order for Tesla's deportation on March 8, 1879. In 1879, the local police commander (Abteilung-Commandanten) in Maribor was the lieutenant Adolph Smole and Taube was not employed anywhere near²⁵¹⁷, which indicates that the writer Praštalo might have been wrong. The Maribor police guards accompanied Tesla to his hometown Gospić as it was usual to exile the illegal immigrants to their domestic

places and Tesla was still underaged according to Habsburg laws. Tesla was probably under arrest on the later International Women's day celebrated after 1909 and the day after. Tesla's rumour behind the bars was Anton Klaus born south of Ljubljana or in Škofja Loka before the Maribor policeman handed him over to Ljubljana officials. Tesla and Anton Klaus were punished for similar crimes as vagabonds and afterwards deported to Gospić and Ljubljana. In 1884, the authorities started to build Maribor men's prison only after Tesla's forced depart in 1879. In those years there was nobody with family name Klaus in Ljubljana except for the Viennese born architect Karl Klaus (* January 27, 1889), but somewhat later we find numerous persons named Klavs or Klaus as workers or housewives born in the neighbourhoods of Bela Cerkev, Ribnica, Velike Lašče, or Turjak.²⁵¹⁸ In 1879, the right bank of Drava River part of Maribor district attorney (Bezirk Richter) was Alojzij Čeh (Alois Tschech), but immediately after Tesla's debacle he became land law-court counsellor in Ljubljana.²⁵¹⁹

Maribor was a quickly expanding city full of outlaws in the era when Tesla tried his luck there. In Tesla's times in 1878, the Maribor city security police arrested 1740 lawbreakers which was 181 more than in 1877. Among them they exiled 131 persons, 555 persons were transported with force to their hometown as Tesla was exiled *mit Schub in die Heimat befördert*, in Tesla's case *mit Schub nach Gospić befördert*. 243 guys were punished in their hometowns and were not added to the total of 1740 Maribor penalties, 767 were discharged with rebuke after few hours of police arrest, and 287 of arrested guys were handed over to the law court. The main city emigration station 'welcomed' 1165 exiled persons from other similar authorities and all those unhappy folks were promptly transported ahead.²⁵²⁰ Tesla was no exception of that crazy routine which prevented the tired Tesla's jailers from anything about Tesla's talents.

In 1879 the authorities of Maribor took over 1335 persons and transported them ahead which was 170 more than the previous year.²⁵²¹ In Tesla's times

²⁵¹⁴ Podgoršek, ibidem, p. 366-367; Leskovec, ibidem 1991, 271.

²⁵¹⁵ Hof- und Staat... Wien 1879 p. 419.

²⁵¹⁶ Hartman, 1983, 128; Leskovec, 169, 175; Leskovec, ibidem 1991, 259, 267; SI_PAM/0005, Mestni računski knjigi 1869 & 1900.

²⁵¹⁷ Hof- und Staat... Wien 1879, p. 440.

²⁵¹⁸ SI_LJU 500, Domovinski oddelek, microfilms 403 and 567.

²⁵¹⁹ Slovenski gospodar, 13 (1879), 11, March 13; Hof- und Staat... Wien, 1779, p. 430.

²⁵²⁰ Marburger Zeitung, 18 (1879), January 5, pp. 2-3.

²⁵²¹ Marburger Zeitung, 19 (1880), March 4, p. 3.

the elected vice-mayor was Stampfl, and four Maribor city counsellors were Johann Girstmayr, Marco, Ludwig Bitterl von Tessenberg, and dr. Josef Schmiderer (Schmiederer) who was president of Philharmonic Society, deputy of state parliament, and deputy of land parliament. The financial matters were entrusted to the big landowner Kokoschinegg from Čebelarska (Beekeeper's) Street No. 18 and soap-manufacturer Franz Bindlechner (* 1820; † 1897) from Gosposka Street No. 13 who was the members of Maribor Loan Bank Board, the laic official (key-keeper) of Cathedral, and unsuccessful candidate for former Duhač's Viennese PM post in the list of government's national Clerical Party in 1880.²⁵²² The members of control commission for gas-lighting were Wiesinger, the president innkeeper Johann Girstmayr (Girstmajer) from Graz Street of today Vetrinjska Street No. 12, Dr. Lorber, the librarian of Manufacturers' Society established on January 16, 1882 Karl Flucher (Fluch), and Franz Bindlechner.²⁵²³ Just before Tesla's exile the adjunct of Maribor district law-court dr. Alois Banmann got the similar job in the Styrian city Mureck (Cmurek).²⁵²⁴ Because of so frequent expulsions from the city of Maribor, the officials did not have time to examine Tesla's talents at all. There were many other events in the city of Maribor to be aware of and Tesla's case seemingly interested no one as no prophet predicted how important Tesla will become. The Maribor folks were more interested in the suit of Fala near Ruše landowner baron Max (Maximilian Ignac) Rast considering his supposed offence in the local Ptuj press,²⁵²⁵ and most of all the lost suit of the Schoolmaster of Teachers' preparatory College (k.k. Lehrer-Bildungs-Anstalt) and inspector of Maribor city schools dr. Anton Elschnigg (Elschnig, Elšnik, Director of K.K. Lehrer-Bildungs-Anstalt in Maribor) against the Schoolmaster of Girls' School (Director of Bildungskurs für Arbeitslehrerinnen) Alojz Habjanitsch (Habjanič) dealing with the physical assault during the defence against attack with a chair in Habjanič's own office. The lawsuit of Maribor District-Court of the left bank of Drava River took place in Wednesday March 5, 1879 between 3 p.m. and half past 6 p.m. Habjanič's

lawyer was a member of the disciplinary committee and counsel (Ausschusses und Disciplinar-Rathes) dr. Julius Kosjek of Graz while Elšnik did not hire any lawyer at all. The rooms were so crowded that they had to lock the door. The law-court adjunct of Maribor right bank of Drava River Karl Nadamlenzki led the trial and the law-court adjunct of Maribor's right bank of Drava River Slovenian politician dr. Franc Voušek (Vouschek) represented the state public prosecutor. The witnesses were the city school counsellor mayor M. Reiser, the city counsellor Marco dr. Schmiderer, the Schoolmaster Frank Stampfl of probable Gottscheer descent, Arthur Mally, the teacher of gymnastics master of exercises Rudolf Markl (Markel) who was also librarian of German Turnverein, the School-servant Stracher, the retailer Leth, and the schoolmistress of Habjanič's Girl's-School Maßenauer (Matzenauer) whose relative served in Klagenfurt (Celovec) and in peripheral Carinthia in 1879. On Saturday January 25, 1879 in 3 p.m. the school inspector of Maribor Elšnik entered Habjanič's office in the time when school provided just French language lessons. Elšnik acted in his function of school inspector and demanded the school diary to check about his daughter as a schoolmistress of Girl's-School who supplied her colleague Janžekovič. Habjanič have accused miss Elšnik of taking holidays because of her illness but in the meanwhile, she supposedly had fun with skating without her collaborator-boss teacher Matzenauer. Elšnik's friends stated that they could prove the opposite. The schoolmaster Habjanič supposedly scolded his fellow schoolmaster Elšnik as a liar, hypocrite, and smacked his face, which forced Elšnik to hand up a chair. Habjanič denied and admitted just a loud quarrel. The teacher Matzenauer and her girl-students heard the noise and rushed to witness the fight, but according to other sources they didn't observe the event because they escaped out of the building in fear. On the next day the land school inspector (Director of K.K. steiermärkischer Prüfungs-Commission für allgemeine Volks- und Bürgerschulen in Graz) dr. Johann Alexander Roschek (Rožek) from Graz ascertained the striped wound on Elšnik's face. The future author of Maribor-Streets description, the local physician's son, head physician of the Maribor hospital's medical department Dr. Arthur Mally (1843-1919) treated Elšnik's wound on February 3, 1879. The mayor suspended Elšnik from the post of school inspector despite of the fact that the Viennese

²⁵²² Domovina (Celje), 7 (1897), 5 January 29, p. 4.

²⁵²³ Marburger Zeitung, 18 (1879), January 5, p. 2; Hartman, ibidem 2009, pp. 89, 116, 190, 274.

²⁵²⁴ Marburger Zeitung, 18 (1879), 9, January 19, p. 3.

²⁵²⁵ Slovenski gospodar, 13 (1879), 5, January 30, p. 39.

government and not the mayor hired Elšnik. The mayor knew that he acted beyond his authorities as he did few months earlier with his ban on Slovenian talk during the erection of the bishop Slomšek's monument in the Cathedral. Therefore, the mayor explained that he tried to stop further fighting between Elšnik and Habjanič. The law-court refused Elšnik's accusation therefore he had to pay 10 florins to the local School-Fund. The public applauded Habjanič's release as his behaviour was described as self-defence. The happy Habjanič was released with an acclamation from the audience: "Bravo". Both fighters were eventually dismissed from Maribor as Georg Kaas got Habjanič post in 1880 while Elšnik's post remained vacant in 1880. In 1881, Georg Kaas retained Elšnik's post and Habjanič post passed to Joseph Riedler. In 1875-1880, Elšnik and Georg Kaas's employee was the professor of mathematics Luka Lavtar, who kept his job without any additional fights.²⁵²⁶

Habjanič was the schoolmaster of Girl's-School already in 1869,²⁵²⁷ while the mountaineer and zoologist Anton Elšnik (* 1827 Sv. Jurij (St. Georg) in Slovenske Gorice) was professor of Trieste Gymnasium between the years 1861-1865, and professor in High Real School in Salzburg in 1869 before he became the professor of Maribor High Real School in 1870 and later the Schoolmaster of Teacher's preparatory College in Maribor.²⁵²⁸ In 1839/40 in his 3rd grammatical class of Maribor Gymnasium Elšnik was the best student with first premium while the later admiral Tegetthoff (* December 23, 1827) was praised as one of his nearly equals in knowledge (his proxime). Elšnik and his wife Antonie Braun also

²⁵²⁶ Marburger Zeitung, 18 (1879), March 2, pp. 2-3; Marburger Zeitung, 18 (1879), March 7, p. 3; Slovenski gospodar, 13 (1879), 6, Februar 6, p. 44; Slovenski gospodar, 13 (1879), 8, Februar 20, p. 60; Slovenski gospodar, 13 (1879), 10, March 6, p. 79; Cverava, ibidem, 41; Hartman, ibidem 2009, p. 271; *Hof- und Staat...* Wien 1879: pp. 432, 426; 1880: p. 435; 1881: p.234.

²⁵²⁷ *Z. öst. Gym.* (1869).

²⁵²⁸ Verhandlungen der kaiserlich-königlichen zoologisch – botanischen Gesellschaft in Wien, Wien, 15 (1865); Anton Elschnig, Übersichtliche Darstellung der Wärmeverhältnisse im Thierreiche. Triester Gymnasialprogramm vom Jahre 1861; Anton Elschnig, Kurzgefasste Anleitung zu barometrischen Nivellirungen mit Quecksilber- und Metallbarometern, nebst e. Anhang, zahlr. barometrisch u. trigonometrisch bestimmte Höhen von Salzburg enthaltend. Jahresberichte der k. k. Oberrealschule in Salzburg. Salzburg, 3 (1869).

had a younger son Anton Elschnig (* August 22, 1863 Lipnica (Leibnitz) in Styria; † 1939) who promoted in Graz and became the leading ophthalmologist. With such scandal at hand, nobody in Maribor was interested in Nikola Tesla's whereabouts which soon proved to be much more important than those little sweet boxing between schoolmasters.



Figure 18-57: On February 16, 1879 in Tesla's Maribor neighbourhood in Tegetthoffstrasse No. 21, Veltée's Panopticon performed their final local show with the moving projections of exotic animals, advertised on the right corner of a page.²⁵²⁹

The scandalous schoolmasters' trial could be considered as another victory of mayor's German party against the Slavic elements in Maribor, and three days later the same antagonism during the much shorter and unattractive trial caused Tesla's exile. As in the earlier case of Pontius Pilate in Near East, the later history proved judges and contemporary lawsuits as unimportant and just their victims Christ and Tesla's fame never faded away. The times were especially hard after German candidates Seidl and J. Seeder lost their Maribor polls on September 12, 1878.²⁵³⁰ The Schoolmaster of Celje Gymnasium Svoboda punished thirty-eight students because they sang Slavic songs in the pub and even tried to sing the Russian Hymn which they probably did not know very well at all even if some Russian travellers passed through Maribor from time to time. Five of those naughty

²⁵²⁹ Marburger Zeitung, 18 (1879), January 26, p. 4.

²⁵³⁰ Slovenski gospodar, 13 (1879), January 1.

drunken brave students were exiled because of high-treason and they lost their stipends and the other thirty-three were imprisoned. The editor of Slovene Maribor journal Dr. Lavoslav Gregorč (* 1839; † 1924) doubted if the punishment will be similar for any singing of Prussian songs.²⁵³¹ Formally, the Russians and the Prussians who just united Bismarck's Germany were equally hostile to

Habsburg's pride, but in fact the German nationalists were getting brasher and stronger in Viennese networks. In Tesla's Maribor days of preparation for the celebration of Imperial silver marriage anniversary the national feelings of Maribor native folks were especially delicate.

Tesla was exiled soon after carnival in the very beginning of the fasting. In those times on February 16, 1879 in Tesla's Maribor neighbourhood in Tegetthoffstrasse No. 21, Veltée's Panopticon with the moving projections of exotic animals performed.²⁵³² Louis Veltée's ancestors were from Lyon of the inventor-brothers Lumière. Together with his children and grandchild Louis Veltée used to be a pioneer of Viennese cinema. Louis Veltée's daughter was the later famous film director Luise Fleck (Luise Kolm, Luise Kolm-Fleck, Louise Veltée, 1 August 1873–15 March 1950). Louis Veltée's son Claudius Veltée later also became known as a film director. On August 26, 1896 in Viennese downtown Louis Veltée opened the wax-figures museum with a steady fixed Panopticon.

In Maribor Casino the family tombola was performed in Tesla's time.²⁵³³ The editor Wiesthaler informed his readers of the leading local German newspaper in Maribor on the Habsburg occupation of Bosnia, on the preparations of silver-jubilee of marriage of Imperial couple celebrated on April 24, 1879 on the political fights of Viennese powerful parties between the Prince Auersperg, Taaffe, and Count Hohenwart,²⁵³⁴ and on the organization of monument-erection of Maribor native admiral Tegetthoff which was attended by the Emperor himself in 1883 before the Viennese Internationale Elektrische Ausstellung. Certainly, the monument of admiral Tegetthoff had much less problems than the monument of the bishop Slomšek. Wiesthaler reported on Emil du Bois-Reymond's (* 1818; † 1896) speech in Bremen about the age of Earth,²⁵³⁵ of the streets of San Francisco as the first ones illuminated with electricity worldwide linked with the lighting up of the reading-room of British Museum of London.²⁵³⁶ Wiesthaler advertised Maribor photographer Henrich Krappek, electrical

Keine Kerze mehr!

Petroleum-Sparkerze in Kerzenform, womit man um $\frac{1}{2}$ Kreuzer Petroleum das größte Lokal 10 Stunden brilliant beleuchten kann. 1 Stück aus Metall 30 fr., aus Porzellan 40 fr.

Elektrische Bündelmachine in der Größe eines kleinen Telegraf-Apparates, höchst elegant ausgestattet, aus Ebenholz mit Bronze verziert, eine Bierde für den elegantesten Salon. Mit einem Finger die Batterie berührt und es entzündet sich das dabei stehende Lämpchen, wo man im Ra Licht hat und ist selbst, da jede Gefahr ausgeschlossen ist, der leichtesten Handhabung und der staunenden Billigkeit halber für Reich und Arm bestens zu empfehlen, besonders für Raucher, Krankenzimmer etc. Preis per Apparat fl. 4.50.

Licht in der Westentasche.

Eine auf der Ausstellung in Paris 1878 prämierte Erfindung, welche es Jedermann ermöglicht die größten Entfernungen auf freiem Felde tagelang zu beleuchten. Diese Laterne kostet lackirt fl. 1.50, feiner aus Nidel mit Feuerzeug und Sprungwert fl. 3 bis fl. 4. (198)

Das Bündelhölzchen hat sich überlebt!

Elektrische Selbstzünd-Feuerzeuge, womit man im größten Sturm Feuer machen kann. Der ganze Apparat ist in der Größe einer Pliege und kostet 1 Stück 10 fr. feiner mit Uhrwerk aus echtem Nidel, nie abzumüssen, 1 Stück fl. 1.50 bis fl. 2.50.

Salon-Feuerwerk, geruch- und gefahrlos, 1 Karton, enthält 12erlei verschiedene effektvolle Zimmerfeuerwerke, Jedes anders, sammt Belehrung. Der ganze Karton 95 fr.

Elektrische Sonne, ganz neu, gibt ein elektrisches Tageslicht, das höchste was bis jetzt in Beleuchtung erfunden wurde. Die stärksten 50 Gasflammen werden verdunkelt, wenn dieses Licht angezündet wird; sehr empfehlenswert für Kranzchen, Wälle, besonders beim Cotillon-Tanz zu verwenden und kostet 1 Stück fl. 3.50, größere fl. 5 bis fl. 8.50.

Der Hausfreund. Ein sehr verwendbares Instrument für jede Haushaltung, erfüllt 14 verschiedene Zwecke, als: Hammer, Säge, Nebel etc. per Stück 75 fr., so auch die neuesten Pipen-Körke, auf jede Flasche zu verwenden. Um die Flasche zu entleeren braucht man nur den Hahn zu öffnen. 1 Stück 45 fr.

Amal-Bouquons in größter Auswahl, enthaltend Karrentappen, tomische Kätzge, Thierköpfe etc. etc. zu den billigsten Preisen von 8 fr. angefangen bis 60 fr.

Bouquet-Fächer, ganz neu; selbst stellt ein prachtvolles Bouquet vor, mit dem feinsten und schönsten Blumen ausgestattet, die beinahe von den echten nicht zu unter-

Figure 18-58: Advertising for electric lighters, lamps and similar vacuum devices awarded at the Paris World Exhibition in 1878, just one day before Tesla's arrest (Marburger Zeitung, March 7, 1879, page 4).

²⁵³¹ Slovenski gospodar, 13 (1879), 10, March 6, p. 78.

²⁵³² Marburger Zeitung, 18 (1879), January 26, p. 4.

²⁵³³ Marburger Zeitung, 18 (1879), March 23, p. 2.

²⁵³⁴ Marburger Zeitung, 18 (1879), February 14, p. 3.

²⁵³⁵ Marburger Zeitung, 18 (1879), January 5, p. 2.

²⁵³⁶ Marburger Zeitung, 18 (1879), February 14, p. 2.

lighter, lamp and similar equipment rewarded in Parisian World Fair in 1878.²⁵³⁷ The funny destiny decided that the Viennese lecturer professor G. Egestreß came to talk and experiment with Edison's phonograph in the Chemistry lecture-room of Maribor High Real School with an entrance-fee of 30 kr on March 21, 1879 in 6 p.m.²⁵³⁸ just after Tesla's exile. Tesla would have liked to join the fans, but he had no such luck.

18.5.15 Gospić Again

It's a pity that the *Pokrajinski arhiv* Maribor today keeps just the notes of documents considering Tesla's deportation under the numbers 2160 »p«,²⁵³⁹ number 2675 »H«, and 7019 for Tesla, and number 2659 for Klaus. There is no trace for the documents themselves in Maribor, nor in Styrian Lands Archive in Graz. Those small notes of policemen were probably not considered to be worth of keeping. Whatever were the peculiarities, Nikola's father Milutin who was never very healthy went ill that winter after he returned to Gospić from his search. Milutin died without Nikola near his deathbed on April 17/30, 1879.²⁵⁴⁰ Mojo Medić eventually gave the funeral speech. Milutin and Nikola had their dispute in Maribor, Milutin decided to use his paternal authority and they probably never resolved their quarrel. Nikola's mother was different and politer, but Nikola already suffered from the early death of his elder talented brother during their horse sledding winter adventure on a hill above their Smiljan house and Orthodox church, and now Nikola had another unresolvable trouble on his back. He probably gambled and drank a little bit more in Gospić, but finally matured under the carrying eyes of his sad clever mother.

How did it feel to be humiliated by one's own father before causing your father's death like a

²⁵³⁷ Marburger Zeitung, 18 (1879), March 7, p. 4; Marburger Zeitung, (1879), March 16, p. 3.

²⁵³⁸ Marburger Zeitung, 18 (1879), March 21, p. 2.

²⁵³⁹ Pištalo, *ibidem* 2012, p. 83 is the only note about Taube according to Russian sources (Vladimir Pistalo's email Tuesday 19 March 2013).

²⁵⁴⁰ Mrkić, *ibidem*, pp. 36-37, 39; SI_PAM/0005, Mestna občina Maribor, Geschaefts Protokoll 1879 No. 2160 March 8, 1879 and No. 2675 March 24, 1879; Jovanović, *ibidem*, pp. 51-52; Andrej Detela, Nikola Tesla: globina ni dovolj, potrebna je jasnina. In: Nikola Tesla. Moji izumi. Ljubljana 2013, p. 130; Matična knjiga vjenčanih i umrlih Parohije Gospić 1885-1940, *Državni arhiv u Gospiću*.

kind of Oedipus'patricide? After his shameful deportation Tesla taught the Orthodox religion in the Lower Real School of Gospić for a while as the substitute for his deceased father. Nikola Tesla would rather teach some technical stuff, but he had no academic diploma and Mojo Medić got the job.

After the confirmation of the Graz Commission in 1878/1879, the post of the substitute teacher for natural sciences and physics in the German or Serbo-Croatian language was established at the lower real school in Gospić. Tesla's Orthodox classmate the zoology expert Mojo Medić got the job after he completed his studies of natural sciences and chemistry at the Viennese Polytechnics College. In the autumn of 1879 after a year of teaching together with his old classmate Nikola Tesla, Mojo left Gospić. The dropout student Tesla was not officially set up in Gospić because he had no academic degree, but instead substituted for the religion courses after his father's death in April 1879. On June 1, 1892 Medić met Tesla again during Tesla's brief visit to Belgrade, and Medić became headmaster of Real school in Ruma city in 1921. Medić corresponded with Tesla between the two wars, like Tesla's Graz classmate Anton Zorić.²⁵⁴¹

Nikola Tesla and Mojo Medić were the students in the same Gospić school nine years earlier. The school has Tesla's memorial plate and his statue inside, but the next-door Orthodox church was destroyed with no trace left except the memories of the elderly locals. The teaching was Tesla's goal during his Graz studies but now he dreamed more and more about inventing as no military had any power over Nikola Tesla anymore. Tesla tried his luck again in Prague University but after Maribor and other debacles Tesla did not want to learn from others because he felt as their superior. He soon even became reluctant to work for others: and he was certainly right. Despite of relative progress of Maribor know-how in Tesla's time he was unable to stay in Maribor. Considering his later career, we could only regret that Tesla did not make his

²⁵⁴¹ *Verordnungsblatt für den Dienstbereich des K. K. Ministeriums für Kultus und Unterricht. Jahrgang 1880.* Wien: Staatsdruckerei, 336; http://www.novosti.rs/dodatni_sadrzaj/clanci.119.html:28007-0-Nikola-nece-mantiju; http://gimnazija-gospic.skole.hr/upload/gimnazija-gospic/newsattach/32/Skolski_plan_-_2011_12.pdf p. 2; http://www.novosti.rs/dodatni_sadrzaj/clanci.119.html:28007-2-Tumac-i-cuvar-vere consulted on 26. 2. 2013; Jovanović, 2001, 49-50.

alternative current hydroelectric power plant on Drava river near Maribor instead of Niagara.

18.5.16 Tesla in Prague

Gospić was too small for the humiliated Tesla as his neighbour classmates returned with their advanced schools' diplomas much earlier while Tesla returned with policemen detention. Tesla's uncles as higher military officers enabled his studies in Prague where Mach was the leading erudite, but electrotechnics was not Mach's primary goal. There was no German provocation in Prague like Tesla experienced it in Graz, but Tesla preferred billiard anyway. Budapest, Strasbourg and Paris were next steps and Tesla finally left to USA for good. To enable his better salary in Edison's firm the uncle sent to Tesla the copy of Tesla's high school diploma of Rakovac overseas.

Name und Stellung	Lehrfach	Fachsprache
Fiumi Johann, Ritter von, Supplent an der Staats-Realschule in Rovereto	Chemie für Ober-, Physik für Unterrealschulen	italienisch
Fischer Gustav, Supplent an Realgymnasien in Bielefeld	ditto	deutsch
Garnzopff Karl, Ritter von Thurnau, Assistent an der Universität in Graz	ditto	deutsch
Gödel Josef, Lehrantenassistent in Graz	Chemie und Physik für Unterrealschulen	ditto
Schubert Stanislaus, Assistent an der technischen Hochschule in Brünn	Chemie für Ober-, Naturgeschichte für Unterrealschulen	ditto
Smolka Alois, Lehrantenassistent in Proßnitz	ditto	ditto
Postl Adolf, Lehrantenassistent in Graz	Chemie und Naturgeschichte für Unterrealschulen	ditto
Kraszny Franz, Supplent am Staatsgymnasium in Landshut	Naturgeschichte für Ober-, Physik für Unterrealschulen	deutsch
Medić Moja, Supplent an der Central-schule in Gospić	Naturgeschichte und Physik für Unterrealschulen	deutsch und serbo-croat
Sikula Anton, Lehrer an der Bürgerschule in Rakovec	ditto	deutsch

Der Minister für Cultus und Unterricht hat das **Öffentlichkeitsrecht** erteilt: der Privat-Mädchen-Volksschule der Nichte **Kalman** in Wien. (Ministerial-Erlaß vom 17. Juli 1878 N. 10724)

Figure 18-59: The setting of Moja Medić as a physicist in Gospić in 1878/79. The dropped-out student Tesla was not noted (Verordnungsblatt für den Dienstbereich des k.k. Ministeriums für Kultus und Unterricht. Jahrgang 1880. Wien: Staatsdruckerei, 336).

In Maribor, Tesla may have saved some money for studying in Prague, which he did not undertake more seriously; of course, Tesla got a lot of money from his mother, and much more from his uncle

Dane Branković and from his other two uncles. The additions came through Tesla's salaries in

Gospić school, and more from the playing billiards in Zlata Praha (Golden Prague), with which Tesla later boasted during his US interviews.

The teaching was Tesla's goal during his Graz's studies, but he was increasingly dreaming of inventing. He probably fulfilled his promise or at least his father's wish when he tried to finish his studies at the Polytechnic in Prague in the spring semester began in January 1880. In Maribor, he may have saved something for studying in Prague, which he did not undertake even seriously. Of course, his mother brought a lot of money, and much more Dane Branković together with the other two neighbors. The additions came in the middle classes in Gospić, and more and more playing the billiards in golden Prague, with which Tesla later boasted during US interviews.

In 1881, they started introducing the electric public lighting and the first telephone connections in Prague, which certainly interested Tesla. Nevertheless, the gambler Tesla in Prague never paid a school fee or passed exams. Tesla also enrolled two mathematical lectures in German language and a philosophical Stumpf's lecture on David Hume. The professor Karl Domalip (Domalip, * 1846; † 1909) announced his lectures of experimental physics in Czech language before the Prague University split into the German and Czech parts in 1882. The similar split happened in the Prague Polytechnic as early as 1869. In 1867/68, Domalip was a student of the first year at Ernest Mach's class immediately after Mach came from Graz to Prague; Domalip's classmate was the later professor of Zagreb university Vincenz (Čeněk) Dvořak. In 1877, Domalip became a private assistant with Mach's support, and later Domalip was also the first assistant to Adalbert Karl Waltenhofen (* 1828; † 1914) at the Prague German Technical University. In the autumn semester of 1879/80, the private assistant Domalip did not only lecture on experimental physics (Electricitätslehre) and exercises (Übungen in der Experimentalphysik), but also by Mach's influence taught the history of electricity under the German title Electricitätshre and ihrer historischen Entwicklung. Unfortunately, Tesla did not enrol in that course.

During Tesla's "studies" in Prague, Mach was there a rector for his first time, but Tesla did not enroll his daily lessons of the Experimentalphysics class. Tesla also did not register on Mach's one-hour public lectures *Theoretische Ergänzungen zur Experimentalphysik*. On February 17, 1880 Tesla may have listened to a popular lecture by Mach in a physical lecture room at Lotus Union under the title *Über die Theorie des Radiometers und ein an die Radiometeranordnung anknüpfender Versuch*, which Tesla certainly upgraded later in his subsequent vacuum experiments with Crookes radiometer. Domalip started teaching electrical engineering as a professor barely after graduating from the university in 1884/85, and in 1893 he took over the newly established Chair of Electrical Engineering at Prague Czech Technical University (*Česká škola technická*, School of strojního a elektrotechnického inženýrství). In January 1896, Domalip set up his first experiments with newly discovered X-rays, which Tesla also dealt with some controversy involved. Domalip published mostly in the domestic Prague Magazine for mathematics and physics. Domalip authored several books and a textbook for electrical engineering. He used the valuable help of František Kolářek (* 1851; † 1913). František Kolářek published altogether a dozen articles in *Časopis pro pěstování matematiky a fyziky* of Prague based *Jednota českých matematiků*. Among them Tesla praised the most an interesting Kolářek's Czech article written in Brno on electrometers.²⁵⁴² Kolářek relied on W. Thomson's nomenclature while Kolářek described Daniel, Maxwell's and other devices which Tesla used in Budapest in that time. Kolářek developed his own electromagnetic theory of light based on the foundation of mechanics and published it in *Ann.Phys.*

In 1886, when Tesla already left for USA, K. Domalip published the Czech article which could be extremely interesting for Tesla under the title *O elektrických strojích influenčních [On the electrical influence machines]*. *Časopis pro pěstování matematiky a fyziky*, vol. 15, issue 4, pp. 157-170. That was the only Domalip's s publication edited by Prague *Jednota českých matematiků*. In 1867/69, K. Domalip gave a paper on the session of *Jednota českých matematiků* under the title *O elektřině* (June 26, 1869), Č.

²⁵⁴² O elektrometrech. *Časopis pro pěstování matematiky a fyziky*, vol. 11 (1882), issue 4, pp. 251-265; Jungnickel & McCormach, 1986, 2: 97, 104, 106, 315.

Dvořák lectured by the title *O mechanické theorii tepla* (July 10, 1869), while Jos. Hervert gave the speeches: 1. *O úkolu fysiky, o poměru fysiky k fyziologii a psychologii a o methodě fysiky* (26th November 1869). 2. *The Importance of Insulators in Electric Theory (O významu izolatorů v theorii elektřiny* on 11th February 1868). 3. *On the elliptical orbits (O eliptické dráze oběžnic*, 24th April 1869). 4. *The Mechanics of Solid Bodies (O mechanice pevných těles*, 26th June 69). 5. *The Mechanics of Liquid and Gaseous Bodies (O mechanice tekutých a plynných těles*, 10th July 1869). In Prague, Tesla became acquainted with the work of his year and the half younger Viennese colleague later professor of Electrotechnics and rector of the Viennese Polytechnic (Technische Hochschule) Johann Sahulka (Sakulka, * 1857 Deutsch-Wagram; † 1927 Vienna).²⁵⁴³

Table 18-10: Prague classes for which Tesla applied without passing through any exams²⁵⁴⁴

Lecture	Number of weekly hours	Professor
Analytische Geometrie des Raumes	2	Durege
Practicum in experimental physics (Cviceni v experimentální fysike)	2	Domalip
Zahlenlotterie	2	Puchta
Über David Hume's »Untersuchung des menschlichen Verstandes«	1	Stumpf

Heinrich Jakob Karl Durege (Durège, * 1821; † 1893) arrived in Prague in 1864 from Zürich; first to the Polytechnic Institute and then to the University in 1869. In the autumn semester 1879/80, Durège taught Differential and integral calculus, curves in space, curved surfaces and mathematical exercises. In the spring semester of 1880, he switched to the second stage of the Differential and Integral calculus, while at the

²⁵⁴³ S. Mirčevski, M. Cundev, Z. Andonov, 2007, Development of the induction motor from Tesla until today. *14th international symposium on power electronics*, Novi Sad, 21; Kulišić, 1936, 13; Johann Sahulka, Bestimmung des mechanischen Aequivalentes der Wärme aus der Wärmeausstrahlung. *Annalen der Physik*, 1890. Band 277, Heft 12, 748-755 .

²⁵⁴⁴ Pichler, 2004, 4; Marinčić, 2006, 41.

same time he lectured on the Analytical Geometry of the Space, which should be attended by Tesla two hours a week. Before Tesla's arrival, Durège published *Elemente der Theorie der Functionen einer Complexen veränderlichen Grösse. Mit besonderer Berücksichtigung "Der schöpfungen Riemann's"*. Leipzig: B. G. Teubner, 1864. Durège's book was noted in *Časopis pro pěstování matematiky a fysiky* of Prague based *Jednota českých matematiků*, but Durège did not publish his articles there, probably because of his German language preferences. Puchta also didn't publish in that Slavic language journal.

Figure 18-60: List of Prague lectures that Tesla wished to attend as a 38th student in a row, residing Ve Smečkách (Smechlgasse) number 13 (Archives of the University of Prague, Main Book of Philosophers in the spring semester of 1880; Mayer, 1996, VI / 68)

The private lecturer F. Klein's student Anton Puchta (* 1851 Staré Sedlo in Bohemia; † 1903 Černovice (Чернівці)) lectured on elliptic functions in the autumn semester of 1879/80, then on the theory of numbers and functions of one complex variable; first of them Tesla intended to listen for two hours a week. In 1887, Puchta was offered a chair in the Ukrainian Bukovina Czernowitz (Tserniwzi, Černivci, Černovice, Чернівці). In exceptional cases, they have honored an associate professor from another university with a chair. Puchta developed procedures for calculating curved areas and kept his Ukrainian chair until he passed away. His successor was Robert Sterneck (* 1871; † 1928); Sterneck was replaced by the Bled native Josip Plemelj (* 1873; † 1967), who started his Viennese studies with Boltzmann, Gegenbauer and Escherich. Carl Stumpf (* 1848; † 1936) was a German philosopher and psychologist under the influence of Franz Brentan and Hermann Lotz. He directed the phenomenology of the 20th century, including

his influences on Edmund Husserl. Stumpf works were read by Max Wertheimer, Wolfgang Köhler and Kurt Koffka. Between 1879-1884, Stumpf lectured at the Prague University, while it was divided between German and the Czech parts. Between 1883-1884 Stumpf was the Dean of the Prague German Faculty of Philosophy. He designed the physiology of tones, comparative studies of music and ethnomusicology. When the Prague engineer claimed that he invented a device for changing photos of acoustical waves into sounds, Stumpf looked at the demonstration and angrily put together a devastating critique of that strange ancestor of Edison's invention. God knows if the similar events attracted Tesla to the lectures of Stumpf, who later taught philosophy at the universities of Gottingen, Würzburg, Munich and Halle until he was honored with a prestigious Berliner chair.



Figure 18-61: Tesla's Prague Professor of Mathematics Heinrich Durege

18.5.17 Tesla Celebrated in his Native Central Europe

The Montenegro and Prague Slavic networks might be the first to recognize the rising star of Tesla, while the Prussians and the important Habsburg places followed only after Tesla's clear success in Chicago Fair and by Niagara Falls. Graz, Vienna, Budapest and German part of

Prague networks began to praise Tesla almost simultaneously in 1893/94, although the greatest star of electrical cathode ray tube discharges Ivan Pavlovich Puluj (Johan Puluj, Іван Пáвлович Пулю́й, 1845 Hrymailiv in Galicia in Ukraine–1918 Prague) remained silent about Tesla and published mostly on local big industrial electromagnetic complexes.

In 1869 Puluj graduated with honors from the Faculty of Theology at the University of Vienna and later participated in the very first translation of the Bible into Ukrainian language from original languages and from Russian as a help of Шевчѐнко's (Shevchenko) friend Panteleimon Oleksandrovych Kulish (Panteleymon Kuliš, Пантелеймон Куліш, 1819-1897). Their work was entitled *Svjate pis'mo Novogo Zavitu* (Свѣяте Письмо Старого і Нового Завіту: Мовою русько-українською) in 1871, 1880, and 1887. It was the latest translation rising star of Bible to one of major European languages which caused Arnold Toynbee's revelation when he and his fellow historians recognized that such a numerous nation as Ukrainian existed so long unnoticed in Europe.

Tesla's Strasbourg friend Puluj was J. Stefan and Viktor von Lang's Viennese student, and Klekler's assistant at the Naval Academy in Rijeka in 1874. He used the scholarship of Habsburg ministry of education to broaden his experimental skills as August Kundt's Strasbourg Ph.D. student in 1875-1876 while Kundt organized the Physical Institute in new university of the recently conquered Strasbourg in 1872-1888. In Strasbourg University, Puluj became interested in the phenomena generated by an electric current in a vacuum. In 1878, Puluj's lamp was awarded the Silver Medal at the Exposition universelle de Paris and Puluj was praised again at the International Electrotechnical Exhibition in Paris in 1881. Wächter and Puluj showed their inventions including cathode ray tubes at the Viennese exhibition under Stefan's scientific leadership in 1883. Having mastered the craft of the glass blower, Puluj blew glass tubes for his own experiments, and for the needs of fellow physicists. Among Kundt's students were also Roentgen, Franz S. Exner, Karl Ferdinand Braun, Emil Gabriel Warburg (1846-1931) and the Russian P.N. Lebedev (1866-1912) to form a kind of international experimental networks. In 1882, Puluj was a Viennese university private docent for

physics like J. Finger was for mechanics.²⁵⁴⁵ In that capacity Puluj frequently visited Kundt's lab for experiments on inner friction in extremely rarefied cathode ray tubes with their results jointly published.²⁵⁴⁶ On those occasions Nikola Tesla befriended Puluj as Tesla visited the professor A. Kundt's lab where Tesla learned Puluj's art of producing cathode ray tubes. After conducting a series of studies with gas-discharge tubes, Puluj and Nikola Tesla were the closest to the solution of the nature of radiation generated by cathode rays before J.J. Thomson. In February 1888 in Prague, Puluj might have been slightly more supportive for the controversial fourth aggregate state and the explanations of radiometer of Tesla's friend Crookes than Puluj's Prague predecessor Gintl in 1880. Gustave Glaser (Gustave Glaser de Cew) translated Puluj's opinions from *Chemiker Zeitung* for Edison's Journal *Science*. Puluj noted the electrode particles as the real elements of an electric currents and sputtered the mirrors of all metals except aluminium. Puluj's extreme fine matter called ether fills all space and pierces all bodes, surrounds the molecule, as the atmosphere surrounds our globe. When the quantity of ether is greater than the normal quantity, the molecules are positive electric, otherwise they are negative. Crookes observed the phosphorescence during the restoration of ether's equilibrium and not because of the heated glass. Puluj's unitarian hypothesis maintained that electric current is nothing else but a current of ether. The number of scientists who follows the dualistic hypothesis of electricity is by far greater, but unitarian view deserved attention especially when B. Franklin, the Jesuit Angelo Secchi in 1863 and Edlund in 1871 approved it. In 1880, Puluj borrowed J. Stefan's Viennese inductor of Ruhmkorff for Puluj's experiments which mostly supported Hittorf's results.²⁵⁴⁷ Still, Puluj as most of German writing guys, supported the electromagnetic waves of ether against the particles of Crookes and J.J. Thomson.

After he returned from Strasbourg to Vienna, Puluj continued to study the discharge phenomena. In 1880-1882 he described in detail the visible cathode rays. For some time, the device, known as

²⁵⁴⁵ *Hof- und Staat...*, Wien 1882, p. 121.

²⁵⁴⁶ in *Ann. Phys.* 1878 vol. 155 and in *Wien. Ber.* 1878 vol. 78; Puluj, Ueber die Abhängigkeit der Reibung der Gase von der Temperatur. *Ann. Phys.* 1877 237/6: 296-310.

²⁵⁴⁷ Puluj, 1880, 58-59; Puluj, 1880, 870, 883, 922; Puluj, 1889, 317.

the "Puluj's lamp" was a mass-produced glow discharge cathode ray tube. In 1888/89 Puluj was the rector of German Technical Hochschule in Prague and gave to Roentgen Puluj's cathode rays tubes upon Roentgen's visit in Puluj's Prague laboratory in 1895. Immediately after Roentgen's discovery, Tesla and Puluj published their own X-ray photographs. Puluj's photos were so clear that they enabled the revelations of pathological changes in patients' bodies.

The support of Puluj could be decisive for Tesla as both guys were raised in their strict Orthodox religion, joined their nationalist student organisations, and had similar experimental-business interests in then biggest AC industrial projects. In the years 1899-1900 Puluj served as the rector, and in 1902, Puluj was the dean of the Electrical Department. In 1903 the dean Puluj as the first in Europe established the chair for physic and electrotechnics in Prague Technical Hochschule in accordance with Siemens' pursuits in Germany. The fact that Puluj taught in German and not in Czech Technical Hochschule could mean that Puluj loved his Habsburg citizenship higher than any Pan-Slavism just like J. Stefan which might have prevented greater Puluj's support of the Slavic Tesla. However, Puluj never abandoned his Ukrainian nationalism which was certainly not approved by Poles or Russians. Puluj was a member of Shevchenko Scientific Society (Наукове товариство імені Шевченка) named after the tortured Ukrainian poet Тарас Григорович Шевченко (Taras Hryhorovych Shevchenko, 1814-1861). It was founded in Lvov (Lviv) in 1873 as a literary society devoted to the promotion of literature in Ukrainian language which was prohibited in Russia. In 1893, due to the change in its statute, the Shevchenko Scientific Society was transformed into a real scholarly multidisciplinary academy of sciences with its periodical the *Zapysky NTS* (Notes of the Shevchenko Scientific Society). It still focused on the Ukrainian Studies. Throughout most of its history it had three sections: historical-philosophical, philological, and mathematical-medical-natural scientific. It greatly expanded its activities, contributing to both the humanities and the physical sciences, law and medicine, but most specifically once again it concentrated on Ukrainian studies to publish several hundred volumes of scholarly research and notices by 1914.

Puluj activities for benevolence of his Ukrainians might have been a model for Tesla.

Tesla was a king for a while! But, there's no Sun without the spots. Some antagonists of Tesla's student days never acknowledged their errors, but their younger descendants grew up with Tesla's glory and promoted Tesla's merits. The author of Tesla's abolishment decree from Polytechnic in Graz Franz Xaver Stark von Rungberg (* 1840 Prague; † 1914) belonged to the first group. He studied in his native Prague Polytechnic between the years 1858-1862. In 1869/70 he was constructor of machines as he was attached to the chair of construction mechanics of the professor Gustav Johann Leopold Schmidt (* 1826; † 1883). In 1841-1846, Schmidt studied at the Viennese Technische Hochschule with additional lectures from Viennese university. From 1856 to 1858 Schmidt visited F. Redtenbacher in Karlsruhe to learn how to criticize kinetic theory together with Ernst Mach. Mach became Stark's lifelong model. Stark also worked in commission for locomotive drivers and fireman until he was promoted to the job in Miners Academy of Leoben. Stark had held the chair of mechanics, engineering and construction mechanics, soon also for graphic static in Graz Polytechnic between the years 1872-1886. He was the dean of Engineering (Mechanical) School from 1st October 1874 until 30th September 1876, and the rector of Polytechnic (*Technische Hochschule*) in Graz between October 1, 1877 and September 30, 1878. So, Stark expelled Tesla from Graz studies. Before he learned about the huge mistake he made against Tesla, Stark moved to the German Prague Polytechnic (German *Technische Hochschule*) in 1886. Due to the excess of his office work during Tesla's Graz studies Stark only published his work presented in front of the Graz Polytechnic Club on a new material strength test and the paper *Die sociale und staatliche Stellung des Technikers*. Referat gehalten in der Wochenversammlung des Polytechnischen Clubs in Graz am 10. März, 1877. Tesla was able to see both Stark's performances. In Prague, Stark was the editor and redactor of Polytechnic (*Technische Hochschule*) journal *Technische Blätter: Vierteljahrschrift des deutschen polytechnischen Vereines in Böhmen*. Their *polytechnischen Vereines in Böhmen* was established as Architekten- und Ingenieur-Vereines in Prague in March 1869, but soon it split on

German and Czech parts as did their schools in Prague.²⁵⁴⁸

As a replacement of E. Czuber, Stark edited volumes 23–40 of *Technische Blätter* in 1891–1908. In 1891 in first volume under his redaction Stark published *Beitrag zur Berechnung des kontinuierlichen Trägers* on pages 23: 107-112 of *Technische Blätter*. In 1895, Stark published his paper *Die Energie und Energetik* based on ideas of W. Ostwald on pages 27: 159-173 after Stark's speech in front of Prague Polytechnic Society (Vereins) on 27. 12. 1895. Next appeared Stark's paper *Maßsysteme und Grundbegriffe* in *Technische Blätter* in Prague on pages 26: 167-189 with F. Redetenbacher and E. Mach's mass of a body as the quantity of inertia of the body. Both were the leading authorities for Stark on page 26: 181 in 1894. Stark endorsed the negation of matter, as matter must be a conglomerate of the different energy forms according to W. Ostwald's Lübeck paper against materialism of Boltzmann, Karl Marx, the blind Eugen Dühring's (1833-1921) antagonist F. Engels and similar fellows. Ostwald's energism was very popular for a while as a refutation of the revolutionary and other kinds of materialism, which on its turn defeated the idealistic philosophy of romanticism after the spring of nation of 1848. On 20. 9. 1895, Ostwald entitled his paper as *Overcoming scientific materialism (Die Überwindung des wissenschaftlichen Materialismus)* which speaks for itself and explains why Engels and Lenin were so upset with that kind of ideas; Ostwald was an active pacifist like Tesla, but communism was far from his agenda. Dühring's anti-Semitic positivistic biography of Robert Mayer entitled *Robert Mayer, der Galilei des neunzehnten Jahrhunderts: eine Einfuehrung in seine Leistungen und Schicksale* of 1889, and F. Redetenbacher's living force (*Lebendiger Kraft*) were Stark's chief trumps, both extremely far from Engels' materialism of *Anti-Dühring* of 1877 or later Lenin's *Materialism and Empirio-criticism (Материализм и эмпириокритицизм)* against Mach and Alexander Aleksandrovich Bogdanov (Алекса́ндр Алекса́ндрович Богда́нов Малино́ўскі, 1873-1928) issued in 1909. Stark relied on kinetic energy formula:

$$E = (1/2) \cdot m \cdot v^2 = A$$

²⁵⁴⁸ F. Steiner, *Geschichtlichen... Technische Blätter* 1894 25: 225.

where E was Energy and A was work on page 170, just like Tesla did in June 1900 and Einstein more sophisticatedly finally in his general theory of relativity later. Stark even tried to develop his idea "Matter is Energy" from Maxwell's book *Matter and motion* on Stark's next to last page 172. Stark praised Ostwald as well as Mach and forgot to notice that Ostwald was defeated in Georg Helm's (1851 Dresden -1923 Dresden) arrangement of Ostwald-Boltzmann duel in Lübeck which Stark wrongly described as Ostwald's victory. The duel was in Lübeck during the Congress of German Scientists in September 1895. Years after, Arnold Sommerfeld (1868-1951) described what happened: 'Helm was the champion of energism; then came Ostwald and, afterwards, the philosophical theories of Mach (who was not present at the event). In the opposite corner was Boltzmann, supported by Felix Klein (1849-1925). The skirmish between Boltzmann and Ostwald looked pretty much like a duel between a hefty bull and a trembling bullfighter. Yet on that occasion the bull defeated the man and his agility. Boltzmann's arguments convinced everybody. All young mathematicians like myself were on Boltzmann's side'. After his defeat in the confrontation, Ostwald was very upset as he bitterly wrote to his wife about 'tight antagonism' when he 'faced such an openly hostile group of people'. The harsh contention between Ostwald and Boltzmann, who nevertheless remained friends, was continued through series of papers. Only in 1909 after Perrin's experiments with atoms did Ostwald eventually acknowledge to Sommerfeld that he had been wrong, but Mach never really accepted Stefan-Boltzmann's atoms. Tesla did not acknowledge Boltzmann's victory and Tesla's early 1900 *Problem of Increasing Human Energy* was still a kind of simplified Ostwald's energism designed for broader American public all over again. Stark and his student victim Tesla were therefore extremely close in their philosophical views. Albert Einstein and his family tried in vain to obtain Ostwald's support for Albert Einstein as a young upstart who hid Ostwald's energism in his own general theory of relativity after Friedrich Wilhelm Ostwald (1853 Riga-1832 Leipzig) retired in 1906 to escape from his ungrateful students and to abandon his concepts of antiatomic energism. As Tesla's ether, Tesla's energism was also near mainstream before Fin de Siècle, but not after it.

Einstein taught in German University of Prague next door to Stark's school for seventeen months after April 1911. He was full of jokes about bugs in his own bed and about that half of lunatics which do not discuss quantum mechanics under Einstein widow facing the mental hospital. Einstein socialized with the Prague Jewish community of philosophical-literary debating circle in the salon of the fan of Nietzsche and Richard Wagner the Jewish Bertha Fanta (née Sohr, 1865-1918), or in the pharmacy "Zum Einhorn (U jednorozce)", both in Staroměstské náměstí. There Einstein frequented the Jewish folks and musical-literary society like the Jewish writers Max Brod (1884-1968) and Franz Kafka, the philosopher-Zionist Hugo Bergmann and the physicist Philipp Frank (1884 Vienna–1966 Cambridge Massachusetts), who later replaced Einstein in Prague. Stark probably did not care much for Einstein's Prague popularity as Stark retired in 1912 and the invalided E. Mach already left for the flat of Ernst Mach's son in Munich. In 1897, Stark glorified Mach's *Mechanik* and its development in its 3rd reprint issued in 1897 on pages 29: 183-188. Stark added some notes on Redenbacher's *Die Principen* of 1859 on page 39: 186 and on H. Hertz's last genial work *Principles of Mechanics* published without the concept of force in 1894. Stark probably never mentioned Tesla in public except when he expelled Tesla from Graz school. Sancta Simplicitas.

After Emanuel Fait (1854 Beroun (Verona, Beraun) 20 km southwest of Prague-1929 Prague), next Tesla's Central-European biographer became Tesla's former Hungarian-French boss AC currents' backer Etienne de Fodor (Étienne, István, 1856 Bratislava-1929 Budapest). Emil Müller published a recension of Etienne de Fodor's recent book.²⁵⁴⁹ On 30. 11. 1894 the first Tesla's fan in Prague and Kaliningrad the Sudeten German Emil Müller (22. 4. 1861 Landskron (Lanškroun)-1. 9. 1927 Vienna) spoke in hall of physics of German Technical Hochschule on *Neuer Ansichten über Elektrizität*. Müller relied on Faraday-Maxwell's theory backed by Hertz's experiments for electrostatic induction, dialectic polarisation and the substance of ether.²⁵⁵⁰ Emil Müller studied at

the University and in the Technical Hochschule in Vienna and graduated with a teaching degree in 1885. In 1885/86 he completed his probationary year at the Schottenfeld Realschule, then he was Assistant for Performing Geometry at the Technical Hochschule in Vienna for four years and then until 1892 supplier at the Technological Trade Museum in Vienna. In 1892 he got a position as a senior teacher at the newly built construction school in Königsberg (Kaliningrad) where he received his doctorate in 1898 with the dissertation entitled the geometry of oriented spheres of Graßmann's methods. He habilitated in 1899. In 1902 he was appointed to the Viennese University of Technology as a chair for Performing Geometry, where he worked until his death. He was the founder of the Viennese School of Performing Geometry. He has adapted the introductory lectures for Civil Engineering, Surveying and Architecture students to the latest technical requirements by completely redesigned teaching program of Performing Geometry. His textbooks were widely used. He was a founding member of the Viennese Mathematical Society and for many years its chairman. In 1906 he became a corresponding member of the Austrian Academy of Sciences, in 1912/13 a Rector of the Viennese University of Technology, in 1916 a Hofrat and full member of the Austrian Academy of Sciences. Emil Müller authored *Lehrbuch der Darstellenden Geometrie für techn. Hochschulen 1-2*, Leipzig/Berlin in 1908-1923 and *Vorlesungen über Darstellende Geometrie 1-3, bearbeitet von E. Kruppa*, Leipzig/Wien in 1913-1929.

Emil Müller was clearly a great backer for the famous Tesla. In 1895 on page 27: 91 of *Technische Blätter: Vierteljahrschrift des deutschen polytechnischen Vereines in Böhmen* the engineer Emil Müller reviewed the work of Tesla and his collaborator the director of electric central station in Athens Etienne de Fodor entitled *Experimente mit Strömen Hoher Wechselzahl und Frequenz: Zusammengestellt von Etienne de Fodor; Revidirt und mit Anmerkungen versehen von Nikolas Tesla; mit 94 Abbildungen*, Wien: A. Hartleben, 1894. Next, E. Müller published a recension of W. Weiler's *Dynamomaschine*. E. Müller wrote a recension of book of Edmund Reitlinger's (1830 Pest-1882) Viennese collaborator in magnetized cathode ray tubes research Alfred Ritter von Urbanitzky (* 1852) entitled *Die Elektrizität im Dienste der*

²⁵⁴⁹ *Die elektrische Schweissung und Lötung* of Wien/Pest/Leipzig: A. Hartleben, 1892; Emil Müller, 1892, *Technische Blätter*, 24: 151.

²⁵⁵⁰ F. Steiner, *Geschichtlichen... Technische Blätter* 1894 25: 231-232.

Menschheit: eine Darstellung der magnetischen und elektrischen Naturkräfte und ihrer praktischen Anwendungen: nach dem gegenwärtigen Standpunkte der Wissenschaft, Wien: A. Hartleben, 1895 on pages 27: 92-93.

István Fodor's family lived under tight financial conditions in Bratislava, so he only finished the lower secondary school, which was still more than Edison absolved. Along with his daily work, Fodor studied technics and learned languages. His goals and thoughts were directed by Edison's inventions. In 1880 he traveled to Paris to learn the necessary practical knowledge about lamps with Zénobe Gramme (1826-1901) and the freemasonic Russian inventor of lamps for electrical lighting Pavel Nikolayevich Yablochkov (Jabločkov, Jablochhoff, Павел Николаевич Яблочков, 1847-1894). Through Tivadar Puskás, who represented Edison's European interests in electrical lighting in Paris, Edison used Tesla's and Fodor's abilities for Société Electrique Edison. Edison introduced the incandescent lighting system designed for the cities at the International Electrotechnical Exhibition in Paris in 1881. Puskás and Fodor worked together to prepare the exhibition which was opened on August 1, 1881 while Tesla was involved in less glorious telephone installation works in Budapest. The 125-horsepower Edison's Dynamo was commissioned as the famous Jupiter, while the joker Puskás rather nicknamed it into the Circus Elephant. The famous architect of Parisian Opera Charles Garnier (1825-1898) was also in charge of the committee researching impacts of Garnier's masterpieces on gas illumination. The inventiveness of electricians went hand in hand to amuse the mob. The simultaneous competitive testing of several lighting systems took place in the Opera House itself including Edison's system of "foyer du public", a huge design 54 meters long, 13 meters wide, 18 meters tall. The dynamos were placed in the woods on the corner of the Opera House. On October 18, 1881, the experiment proved the unsuitability of the arc lamps and brought Edison's full victory as the first major European success of lighting with incandescent lamps.

The success accelerated the orders while Tesla had his AC motor vision in Budapest park in February 1882. The main building at Strasbourg Train Station was illuminated by Fodor and finally also with Tesla's knowhow. Tesla was sent to

Strasbourg to resolve the troubles with the local lighting plant in February 1883. Tesla supposedly demonstrated his AC motor to the former Strasbourg French mayor the professor of medicine Émile Küss' (Kuss, 1815 Strasbourg-1. 3. 1871 Bordeaux) employee Bauzin and Bauzin's fellows few months later. Tesla narrated that Bauzin was a former mayor of the city who served his best wine to Tesla after he hid it from the German invasion of 1870/71. No guy with similar Christian or family name was in that position in Strasbourg, in Alsace, nor in whole France. Otherwise, Bauzin's family is frequent in the Alsace and the red wine Saint-Estèphe from Médoc region in Bordeaux which Bauzin hid from the thirsty German soldiers for Tesla is famous worldwide. Otherwise, like usual in Tesla's stories, Tesla just mixed some facts to make them sound better for his audience as Tesla was not aware that the future fans of web might have checked his narrations. Otherwise, Tesla's problems with German pedantic Alsace administration might have been true. The German mayor pastor Otto Back (1834-1917) used to be the Germanizing freak of Strasbourg in 1873-1880, and 1887-1906 as a supporter of Kundt's local institute of physics. Tesla was not a great fan of Germans, but he certainly loved Kundt's lab.²⁵⁵¹

Fodor set up a warehouse in Hamburg and established a branch in Antwerp. At the same time, Fodor directed the installation work in Belgium and the Netherlands until he was recalled to France where Fodor directed Tesla's installation and commissioning of a factory in Ivry-sur-Seine suburb of Paris. In 1882, in St. Petersburg, in addition to several industrial facilities, Fodor illuminated a luxury yacht and part of the royal palace. After Tesla left for USA, Fodor worked in Hungary in 1885, at a sugar factory in Sládkovičovo (Diosek, Diószeg) of southwestern Slovakia, in Tirol, Grenoble, then even in North Africa. Fodor's experiences were summarized in his first book on the incandescent light *Das Glühlicht* published in Vienna in 1885. In Athens, Fodor directed the construction of the city's electric power station, where for the first time, at the suggestion of Fodor, they applied a triple wiring system led by Fodor which began operating in 1889. István Fodor wrote the first European Electrical Welding Manual, which was published as "Electrical Welding and Soldering" in 1892. In

²⁵⁵¹ Bokšan, 1932. *Nikola Tesla*, 312; Tesla, *Moji Pronalasci*, Zagreb: Školska knjiga, 1981, 48.

1893 he arranged the lighting of the Corinthian Canal. He also tried to incorporate Ganz & co. (*Ganz vállalatok*) of András Mechwart de Belecska (Andreas, 1834 Schweinfurt-1907 Budapest) who took over the firm after the Calvinist Ábrahám Ganz's (Abraham, 1814 Unter-Embrach in Switzerland-1867 Pest) suicide. To include the powerful Ganz & co., István Fodor promoted Tesla's AC ideas for design and construction but eventually failed because of Edison's lifelong aversion against Tesla's alternating currents. So, the unconvinced Fodor was forced to return to the usual Edison's system. The Greek King rewarded Fodor with the Knight Cross-medal of the Saviour Order. After short work in Turkey, Fodor became Director of Budapest General Electricity Co. in 1894. Fodor used DC electrification for the illumination of the Andrassy Avenue in Budapest at Körönd. Fodor's more than two decades purposeful activity developed a model DC system of BÁV Rt, (Budapesti Általános Villamossági Rt., Budapest General Electricity Co.). In 1909, BÁV Rt. built streetlights with 38 light arches at their own expense at the Rákóczi út between the Museum Boulevard and the Erzsébet Boulevard of Budapest. After their work gained public satisfaction, the public lighting was built in the City Park, Teréz körút (Boulevard), Erzsébet körút (Boulevard), József körút, Ferenc körút (Boulevard), Andrassy út (Avenue), and Lajos Kossuth street in Budapest in 1911. Fodor's DC power supply was operational until 1962. Fodor authored many electrical engineering, general technical and economics books and studies. He lectured in Germany and in Vienna including the somewhat ecological "The smokeless city and industry" in 1907. In 1911, Fodor personally welcomed his model Edison in Budapest and then in Bratislava. Edison originally planned just to see Vienna, but Fodor convinced him that it would be worthwhile to see Hungary for a few days. Edison was glad while Edison and Fodor cooperation proved that the inventor could be successful businessman if only he was able to please his Maecenas with occasional humility, which Tesla ultimately failed to practice. Tesla was just too clever to worship his usually foolish wealthy would-be investors. In 1894, Fodor was able to be nice for both Edison and Tesla while Fodor with Tesla's help added one of the first Tesla's biographies to Fodor's book focused on AC and impedance phenomena of electrical resonance. Tesla personally revised and amended Fodor's

book and Emil Müller published its glorifying review.

In that way, the German parts of Tesla's former Prague headquarters and Tesla's Budapest networks praised Tesla with Fodor's efforts soon after Tesla's successes in Chicago & Niagara. Boltzmann's best Graz assistant and nephew of his teacher Albert von Ettingshausen (1850-1932) did the same after Albert highly praised Boltzmann immediately after Albert left the university of Graz to replace the retired J. Pöschl in former Tesla's Graz Technical High School in 1890.²⁵⁵² In 1893 in his inauguration rector speech in Graz Technical High School Albert von Ettingshausen proudly remembered Tesla's student years there and forgot to mention Tesla's troubles in Graz. On 11. 11. 1894 just after he publication of Fodor's book, Albert von Ettingshausen lectured for Styrian Society to gain a huge applause with Tesla's pictures of high frequency alternative currents. The title of Albert von Ettingshausen's paper was *Über hochgespannte Wechselströme* as it became usual for the presentation of Tesla's ideas. The classroom proved to be too small for the huge audience. Albert's assistant was Karl Pichelmayer (1868-1914). Before Albert von Ettingshausen, Ignaz Klemenčič, Leopold Pfaundler, Fr. Streintz and other spoke.²⁵⁵³ Pöschl was not a member of *Naturwissenschaftlicher Verein für Steiermark* anymore, but he was still in Graz and he might attend the presentation just for fun to see the picture of his old fan Tesla? Tesla got his glory in his Graz and Prague *Alma Mater*, and soon after Albert von Ettingshausen's death also Graz honorary Ph.D. Ettingshausen glorified Tesla in his speech "Vortragende auch das Bild des Nikola Tesla vor" as "ein geborener Österreicher ist und seine Studien an der Grazer Technischen Hochschule gemacht hat". On 11. 11. 1894 Albert von Ettingshausen lectured in front of *Naturwissenschaftlicher Verein für Steiermark*. There he presented the picture of Nikola Tesla presented in front of the audience of his former Graz teachers, and there was a small lie as Tesla "is a born Austrian and has made his studies at the Graz technical college" because it sounded like Tesla graduated in Graz. Similarly, at the same time, the guys from Prague tried to say that Tesla

²⁵⁵² Stiller, Wolfgang. *Ludwig Boltzmann*. Frankfurt: Harri Deutsch, 1989, 22, 24.

²⁵⁵³ Ettingshausen, 1895, *Mitt. Naturwissenschaftlicher Verein für Steiermark* 31: LI.

graduated in Prague. During Tesla's real studies there, in Prague they were never so kind.

In 1898, the great pioneering researcher of cathode ray tube the Ukrainian Puluj reported on electric waves and wireless telegraphy in his paper published in *Wochenversammlung* on 2. 2. 1898. Puluj noted Faraday and Maxwell but listed only the new research of Righi and Marconi with Morse's device without mentioning Tesla on pages 30: 37-38. On page 30: 197, Stark reported on flying machines. In 1899 they reported on Anton Daul's Mid-European description of Perpetuum mobile in the journal *Technic* (*Technikers*) of New York on page 31: 59. In 1901 on pages 33: 67-71, and 84 they reported on Wilhelm Kress' (1836 Saint Petersburg-1913 Vienna) aircrafts which Boltzmann also supported. In 1902 they reported on vacuum cleaner.²⁵⁵⁴

In 1903, J. Puluj of German Technische Hochschule in Prague discussed diagrams of generators of alternating electric currents designed by Heyland, Kapp and Heubach without noting Tesla on pages 35: 93-113. In 1904, J. Puluj described the local firm Ignatz Spiro (1817-1894) & Sohne Český Krumlov (Krumau) without mentioning Tesla but with the use of G. Ferraris' voltmeter on pages 36: 18-40. In 1907 Stark published his paper *Über Probleme der Knickfestigkeit* with figures on pages 39: 1-28. In review of the book about wireless, Edison was noted but Tesla was ignored on page 39: 197. In 1908 in his last edited volume Stark already published a comparison between direct current (DC) and alternating current (AC) although without mentioning Tesla's name on page 40: 74. Under Stark's editorship, most contributors wrote on mechanical engineering or even on modern aircrafts heavier than air, but except J. Puluj who reported on electrotechnics in nearly every volume, that modern Tesla's field was almost neglected.

During Tesla's Graz studies Stark had a lot of administrative work and published just his speeches in Polytechnic Club in Graz on March 11, 1876 (*Über einige neuere Festigkeitversuche* in

²⁵⁵⁴ on page 34: 104 (Anton Daul, *Das perpetuum mobile: eine Beschreibung der interessantesten, wenn auch vergeblichen, aber doch immer sinnreichen und belehrenden Versuche, eine Vorrichtung oder Maschine herzustellen, welche sich beständig, ohne äussere Anregung, von selbst in Bewegung erhalten soll.* Wien/Pest/Leipzig: A. Hartleben, 1900).

1877 and *Die sociale und staatliche Stellung des Technikers. Referat gehalten in der Wochenversammlung des Polytechnischen Clubs in Graz am 10. März, 1877.* In 1877, both works were printed in Graz in *Selbstverlag des Polytechnischen Clubs*, the first one on thirty-four pages with three tables together with two other technical papers, and the other on seventy pages. After graduation Stark worked in railway wagon fabric in Prague, and hardness of solid matter became his primary field. Tesla may have attended his lectures in Polytechnic Club or at least heard some rumours about them, but Stark probably never understood Tesla's talents.

The Slovenian fans of Tesla soon appeared. The German-Slovenian Maribor authorities certainly made a huge error, but the Slovenians tried to repair it decades later. Between 11th and 20th October 1960 in Parisian 11th General Conference on Weights and Measures (*Conférence générale des poids et mesures*), the electro-engineer France Avčín (1910 Ljubljana-1984 Ljubljana) successfully proposed Tesla's name for the unit of the strength of a magnetic field.

Avčín excelled at fourth session of that meeting of the general conference of weights and measures held at the foreign affairs office at avenue Kléber no 19 in Paris on Tuesday, October 18, 1960, at 3 pm headed by Émile Georges Barrillon (1879 Mézières in Ardennes-1967 Montreuil-sous-bois), the president of the Academy of Sciences of the Institut de France. By point 15 they discussed the International System of Units. That famous event in fact earned Tesla more fame than the Nobel Prize a dozen and a half dozen years after his death. The Austrian Josef Stulla-Götz (1901 Vienna-after 1972) led the event. He received his doctorate in physics and mathematics from the University of Vienna in 1924. He excelled by important measurements of radioactivity and temperatures. As a physicist and expert in metrology, Josef Stulla-Götz became chairman of the Austrian Federal Office for Calibration and Surveying. In the absence of professor Bourdoun (Burdun, Григорий Дмитриевич Бурдун) as the Chairman of the Committee of System of Units, his deputy Stulla-Götz introduced the report on the International System of Units. Burdun defended his doctoral dissertation in 1952. From 1954 to 1962 he was a deputy chairman of his boss Andrej Erofeevič Vjatkin (Андрей Ерофеевич Вяткин,

1903-1970) at the Committee of Standards, Measures and Measuring Instruments of the Council of Ministers of the USSR (Comité des Normes, des Mesures et Instruments de Mesure, Leninski prospect (Ленинский проспект and partly the prospect of Academician Sakharov) 9 b in Moscow (Москва) V 49, Государственный комитет СССР по стандартам (комитет стандартов, мер и измерительных приборов при Совете министров СССР), later Государственный комитет РФ по стандартизации и метрологии (Госстандарт), now Rosstandart). Stulla-Götz noted a century and half after Vega began to introduce metric system in his neighborhood: "One of the tasks of Convention of measures is to perfect the metric system and to promote its expansion. This task includes, as it was deemed necessary, the establishment of a practical system of units for international relations, which could be adopted in all member States of our Convention. Already in 1913, on occasion of the Fifth General Conference, the son of a Swiss horologist pioneer in plasma cosmology Nobel laureate of 1920 Charles Édouard Guillaume (1861 Fleurier in Switzerland-1938 Sèvres in France) as a head of International Bureau of Weights and Measures paid great attention to the MKS system completed by an electrical unit. In 1948, the Ninth General Conference endorsed a request from the International Union of Pure and Applied Physics by repeating that question. They instructed the International Committee to open an inquiry into the opinion of the scientific, technical and educational circles from all countries to make recommendations for the foundation of practical system of units. In 1951, the Tenth General Conference established the basic units of this system, which are well known: meter, kilogram, second, ampere, Kelvin and candela. The International Committee then formed within itself a Committee for the System of Units, composed of seven members of the Committee and the Director of the Bureau Burdun. The Commission deeply regrets that an illness prevented Burdun from submitting the report on the work of this Commission himself and from summing up the very comprehensive presentation he had prepared as annex on six pages of problems concerning the establishment of the International System of Units. The results of Commission's deliberations and the decisions taken by the International Committee have been compiled in the draft resolution submitted on page 87. Finally, I would like to

mention that the International Committee for Metrology legally declared to adhere to the resolution of the International Committee of Weights and Measures on the establishment of the International System of Units. The Committee for Legal Metrology recommends to the Member States of its organization the adoption of this System in their legislation of units of measurement."

The co-editor of Niels Bohr's latest works professor of theoretical physics at Copenhagen Polytechnic Henning Højgaard Jensen (1918 Emb of Blistrup Parish on Mors-2001) proposed that in the list of recommended derived units, the magnetic induction unit should be expressed in Weber per square meter (Wb/m^2) and that the name "tesla" must be deleted. Indeed, it is fair to limit the use of special names for units. There is no question of abandoning the well-known names of units such as farad, henry, etc., but this is not the same case for tesla.

The Armenian professor Valentin Osipovich Arutyunov (Aroutunov, Arutyunov, Осипович Арутюнов, 1908 the capital of Turkmenistan (Turkmenistan) Ashkhabad (Aşhabád, Aşgabat)-1976 Leningrad) as director of the Institute of Metrology of DI Mendeleev in Leningrad in 1956-1975 disagreed with this proposal. He noted on the contrary the tendency to give an individual rather short name to each unit; this is how his country recently proposed the name of " lenz" for the unit of magnetized field strength (ampere per meter), certainly by the Russian expert of Jacobi's electroplating Emil Lenz (1804 Tartu-1865 Rome). The name of Tesla, approved by the International Electrotechnical Commission and adopted the same year by the International Committee, is already used in teaching at Soviet Union.

The professor of theoretical physics of the University of Amsterdam Jan de Boer (1911 Haarlem-2010 Doorn), however, supported the thesis of Højgaard Jensen; he considered that the introduction of special names for derived units can only detriment the clarity of the International System.

Former Naccari's assistant now professor at Polytechnic University of Turin Eligio Perucca (1890 Potenza-1965 Rome) intervened in the same

direction.

President of the Physikalisch-Technische Bundesanstalt in Braunschweig Gotthold Richard Vieweg (* 1896 Topfseifersdorf; † 1972 Kälberbronn) also thought that the use of new names should be restricted; he felt, however, that the name of Tesla was already sufficiently used to be retained. Apparently, it sounded strange because the unit tesla was about to replace the ten thousand times smaller now obsolete CGS unit named after German mathematician-physicist Carl Friedrich Gauss in 1936. Vieweg was certainly a German, but his residence in Braunschweig might be so close to East Germany and his native Saxon Topfseifersdorf was a part of East Germany that he kind a secretly changed sides.

Avčin intervened in favor of the maintenance of tesla which is already included in the laws of some countries. If the removal of tesla is requested, he would then propose to delete the newton too.

Director of Service Belge de la Métrologie Maurice-Jacques Jacob said that his country could not agree to paragraph 10 of the proposed resolution, unless their less imperative character was specified. The decisions of the General Conference have the force of law in Belgium and this would oblige the Belgian Government to prepare a new law.

The director of Parisian observatory André-Louis Danjon (1890 Caen-1967 Paris) considers that the General Conference cannot follow the directives of a Government.

The director International Bureau of Weights and Measures Charles Volet (1895 Vevey in Switzerland-1992) observed in this connection that there is obviously no international police force to ensure the implementation of the resolutions of the Conference; these resolutions have the value of recommendations for each of the member states.

Jensen vainly assured that the unit of magnetic induction could be expressed in Weber per square meter (Wb/m^2). He considered that the name "tesla" should therefore be deleted, since it measures 10,000 Gauss units in now obsolete CGS system adopted in 1936. This was incorrect because Wb measures magnetic flux as a function of space geometry and is therefore useless for

magnetic field measurements. Jansen was supported by Astin who got his PhD from New York University as a student of WA Lewis in 1929. Allen Varley Astin (1904 Salt Lake City in Utah-1984 Bethesda northwest of Washington, Maryland) was director of the National Bureau of Standardization in Washington from 1951 to 1969. During World War II, Astin developed a contact fuse that detonates an explosive device automatically when the distance to the target becomes less than a predetermined value. His invention was embedded in bombs donated to the Japanese in 1945. Astin was an advocate of the incomplete introduction of metric weights in the United States, but he disliked those quarrels because he mostly expected entertainment in Paris in 1960, as the American scientific tourist in Europe usually does. Despite Tesla's American citizenship that Tesla was so proud of, Astin was therefore drawn to the opposing Jensen Cold War pole in a dispute which became aggravated a couple of weeks later by the futile US disembarkation in Cuban Bay of Pigs in April 1961. Astin said that this discussion complicated the task of the Conference; that is why he will abstain in the vote on this resolution, while he approves paragraph 3.

Stulla-Götz said that the decisions of the General Conference morally committed the Member States; for example, the symbol of the prefix deca (da), although embarrassing for Austria, will nevertheless be accepted by his country. He therefore asked the Conference to adopt the resolution which had been proposed.

De Boer again intervenes against the unit tesla and regrets the tendency of electrical engineers to introduce many special names for units. Physicists are of the opposite opinion and, when opinions are divided on the advisability of adding a name to a unit, it is better to obey the experts.

Anutunov disagreed with Perucca who has argued that education is better without too many unit names. He admits that it is wise to study these questions with slow caution and to postpone some proposals, but such a position is not currently justified for tesla.

After one last intervention of Avčin in favor of tesla, the maintenance of Tesla's name for the magnetic induction unit was approved by 11 votes for, 6 against and 12 abstentions.

De Boer considered it unfortunate to use for a unit a name which has collected such a small number of votes. The deputy president of Hungarian National Office of Measures Peter Honti (1907-1981) remarked that the acquired simple majority is sufficiently enough; he proposed, with Arutunov, that the Conference take a decision on the whole of the resolution presented.

Before vote, Perucca and Inspector General of Agricultural and Industrial Products in Lisbon F.A. de Alcantara Carreira drew attention to the name of the unit of mass, the kilogram, whose symbol (kg) is not suitable for a basic unit; how can one indeed think to add to the symbol kg the prefixes of multiples and submultiples (as it already contain a prefix kilo)? They regret that this issue has not been taken into consideration.

Avčín was the only Yugoslavian delegate eligible to vote in than polarized east-west politics where Arutunov stated that the Soviets will use Tesla's unit in any case and Avčín cleverly noted that the unit of Newton should be abandoned if the unit of Tesla would not be accepted in their same packet of novelties. Nobody was prepared to challenge Newton! After those discussions, the resolution of the International Committee on the International System of Units was adopted as whole by repeated 18 votes in favor, 1 against and 2 abstentions in Resolution 12 on page 87. In that way, the Slovenian Avčín at least partly reimbursed the damage done to Tesla in Slovenian Maribor.

Avčín wrote a foreword for Milan Pertot's (1884 Trst-1967 Ljubljana) biography of Nikola Tesla in 1962, while Avčín collaborated with his students and colleagues Venčeslav Koželj (1901-1968), Albert Čebulj (1918 Glarus in Switzerland-1995), and Božidar Magajna (11. 12. 1912 Ljubljana-2012) who studied electrotechnics in Ljubljana in 1937-1941. They published their papers delivered on occasion of quarter of century of Tesla's death in 1968. Two years later, their works were printed as another biography of Tesla for Ljubljana based Elektrotehniška zveza Slovenije in 1970.

On 2. 5. 1935 Avčín graduated in electrical engineering at Ljubljana university in the class of chess grandmaster Milan Vidmar (1885 Ljubljana-1962 Ljubljana). On 29. 5. 1936 *Glas Naroda* in Ljubljana anonymously published about Tesla's approaching 80th birthday with several typographic

and other errors about years involved. In August 10–28, 1936, Vidmar won 9th place among 15 masters at then strongest chess tournament in Nottingham University after he excelled with his fair play during his match against then world champion the Cuban José Raúl Capablanca y Graupera (1888-1942) in London on August 16th on the end of tournament which lasted from 31st of July to the 19th of August 1922. In London, Capablanca won his first place and Vidmar was third after the Russian turned Nazi Frenchman future world champion Alexander Alekhine (Алекса́ндр Алекса́ндрович Але́хин, 1892-1946), but Vidmar could have won in he would not have been so fair to the delayer Capablanca.

After his disappointing Nottingham scores Vidmar embarked his ship named Bremen for the USA. Soon after Tesla's 80th birthday, on 5th September 1936 Vidmar and the engineer of tunnels and bridges Vitomir M. Joksić from Beograd visited Tesla in New York before Vidmar's attendance of the World Energy Congress (Power Conference) in Washington D.C. on September 7-12, 1936 and concurrently therewith second congress of International commission on large dams of the World power conference. Vidmar subsequently published a lot about Tesla whereabouts including Vidmar's speech at on Academic club of electrotechnics in Ljubljana where Vidmar reported about his visit in Tesla's headquarters. In that year 1936 Tesla received his honorary Ph.D. of the technical university of Prague where he once studied, while the honorary Ph.D. of the technical university of Graz where he also studied followed in 1937. In 1936, Tesla got the Yugoslavian Order of the White Eagle of I Class. On 11. 2. 1937, Vidmar described his talks with Tesla. Vidmar compared Tesla to much wealthier Pupin whom Vidmar visited in 1927 and declared that Tesla's lab worth three quarters of million loaned dollars was destroyed with dynamite which Tesla never forgave although his Wardencllyffe Tower lab was bombed two decades earlier as a disastrous nonsense. The poor Tesla worked just for the welfare of all humanity and believed that he had a solution for the wireless distribution of energies which Vidmar did not comment in any further details or opinions. Few months later, the taxicab hit Tesla during his regular pigeons' related walks after midnight in the fall of 1936.²⁵⁵⁵

²⁵⁵⁵ Vidmar, Obisk pri Nikoli Tesli, *Slovenski dom* 11. 2. 1937, no. 33: 3; Bokšan, *Nikola Tesla* 1946; Nagler, Vienna.

Vidmar graduated in Vienna in the class of Tesla's friend Johann Sahulka. Vidmar advanced his chess and transformers' knowhow with his Ganz factory boss Ottó Titusz Bláthy as his personal assistant in Budapest in 1912-1913, three decades after Tesla began his research in that same Budapest. In 1894, Ganz factory guys with Ottó Titusz Bláthy and Kálmán Kandó included understood that Nikola Tesla's induction engine could be used for railway traction, so they began to investigate the problems of three-phase electric system for tractions. Bláthy modified the one-phase generator and transformer into a three-phase one and improved the phase-converter electric locomotive devised in 1923. Vidmar was born five years after Tesla's humiliations in Maribor which made him unable to help, but Vidmar and his students were the decisive Tesla's helpers later.

Since 1902, Vidmar has been studying mechanical engineering and since 1904 he has been an electrical engineer at the Viennese Technical Faculty. He graduated in 1907 and received his doctorate in 1910/11. He passed his first rigorous exam in 1905 and graduated by his second rigorous exam as a mechanical engineer in July 1907. In the meantime, Vidmar passed a partial exam from the basics of electrical engineering, while much more was not possible because the electrotechnical department in Vienna had not yet fully functioned. Vidmar was a frequent guest in Grand Viennese Chess Club where the great magnate Albert Salomon Anselm baron Rothschild (1844-1911) regularly played. In February 1909, as a recently married engineer in Weiz northeast of Graz, Vidmar submitted a dissertation in the field of mechanical engineering *Die Theorie der Kreiselumpen* (centrifugal pumps). In the Foreword, Vidmar mentioned the publisher dr. prof. Fritz Emde (1873 Uszyce in Śląsk (Silesia)-1951 Stuttgart), editor of the *Sammlung Vieweg* collection of Braunschweig: F. Vieweg & Sohn

1953; Popović et all (ed.), The anthology published on 100th anniversary of Tesla's birth in Beograd in 1956; Vidmar, Nikola Tesla, *Slovenski Poročevalec* 14. 1. 1953, volume 14, no. 11; Genij inženjer Nikola Tesla: zanimivosti o njegovem značaju, delu in življenju. *Glas Naroda* (publisher Josip Knaflič (1879-1949), editor Ivan Albrecht). Ljubljana: Narodna prosveta, 29. 5. 1936, 2/121: 5; Vidmar, Milan, 1964. *Spomini (Memories)*. Maribor: Obzorja, 2: 47; Njegovan, Vladimir N. (1884 Zagreb-1971 Zagreb). Nikola Tesla, Zagreb: Prosvjeta, 1956, 67; Milan Vidmar's Visit to Nikola Tesla in Ljubljana reported in Ivan Rakovec's *Slovenski dom* 11. 2. 1937, no. 33: page 3.

from Stuttgart and Vidmar's colleague-classmate Josip Boncelj (1884 Železniki-1971 Zagreb). In 1938, Fritz Emde replaced Wilhelm Dietrich as professor of Theoretische Elektrotechnik and Director of Elektrotechnischen Instituts an die Technische Hochschule Stuttgart.²⁵⁵⁶

In the summer of 1910, Vidmar had a rigorous defense and he was promoted in Vienna at the Technical High School on 16 July 1910. In electrical engineering, in which he later became famous, he was self-taught. In 1910, his mentors in the discipline of centrifugal pumps were not electrical engineers, while the mechanical engineers included:

The physicist and electrical technician Adalbert Carl Ritter von Waltenhofen zu Eglöfsheimb (* May 14, 1828 castle Admontbichl west of Graz in Styria, † 5 February 1914 Vienna) was the first professor and later the director of the Institute of Electrical Engineering at the Viennese University of Technology from 1883 to 1899, nominated during Stefan's Viennese Internationale Elektrische Ausstellung of 1883.

An Austrian electrical engineer Johann Sahulka was the son of the railway expert and studied physics and mathematics at the University of Vienna. In 1881 he passed his master's exam and completed his Ph.D. in 1882. Then he taught at Währinger Realschule from 1884 to 1888 and in Theresianum in 1888/1889. His habilitation at the Technical University of Vienna took place in 1892. He was there as the designer of the Electrotechnical Institute. From 1894 to 1898, Sahulka was employed by the Austrian Standard Legal Commission. In 1899 he became a technical councilor at the Patent Office. From 1903 he was a full professor of electrical engineering at the Technical University. 1909/10 and 1910/11 he was a dean, and a rector in 1913/14.

In 1915, Sahulka received the title of the court counsellor (Hofrat). In 1907 Sahulka advised Milan Vidmar to keep his hands away from electrical engineering and at the same time gave Vidmar a positive grade at the exam to praise him at the five-member commission at the docent examination led by Karl Hochenegg in Vienna on 14 October 1918. In 1899, Hochenegg became a

²⁵⁵⁶ Vidmar, Milan, 1964. *Spomini (Memories)*. Maribor: Obzorja, 1: 31, 292.

professor of electrical engineering. In 1903 he worked for the Ministry of Construction and Operations of Electrical Devices and Communications at the Technical University of Vienna also as Rector in 1906-1907. He was an engineer of the General staff of the Habsburg Army²⁵⁵⁷.

Max Reithofferplatz (* October 27, 1864 in Vienna, † 10 March 1945) was an Austrian university professor of electrical engineering at the Viennese Technical University (TU) and the inventor. After completing his studies in physics, mathematics and philosophy at the University of Vienna, he received his doctorate in 1889 and obtained his teaching qualifications in subjects of mathematics and physics in 1890. Since 1891, Reithoffer was scientific assistant of Adalbert von Waltenhofen, and he received habilitation in electrical engineering in 1898. In 1903 at the opening of the new building of the electrotechnical institute, he was appointed as associate professor. In 1908 he became a professor of electrical engineering and he gained the rank of a counsellor in 1922.

Karl Pichelmayer (* 6 August 1868 Bern village of municipality Bruck an der Mur; † 23 January 1914 Vienna) studied mechanical engineering at the Technical University of Graz. As an assistant to Albert von Ettingshausen, he was engaged in electrical engineering and he became the leading producer of electrical machines for Siemens and Halske in subdistrict Leopoldau in Vienna after 1891. In 1900, he received the gold medal for designing at the World Exposition in Paris. In 1905/06 he was a professor of the construction and design of electrical machines and appliances at the Technical University of Vienna.

In addition to his industrial work August Kann (February 19, 1871 Vienna-September 11, 1937) worked at the Institute of Electrical Engineering at the Viennese University of Technology as a demonstrator between 1903 and 1906. In 1905 he was promoted to the PhD engineer of technology. In 1924 he was appointed as a full professor of electrical engineering at the Viennese University of Technology. In the academic year 1934/35 he was a rector of the university.

Rudolf Saliger (* February 1, 1873, Spachendorf at Freudenthal in Silesia now Leskovec nad Moravicí (Špachov) in Czechian Moravia; † 31 January 1958 Vienna) taught at the Technical University of Vienna in 1910-1933. In 1924/25, he was also a rector of department of science there.

Franz Aigner received his doctorate in medicine and philosophy in 1907. Then he became an assistant to G. Jager, an associate professor in 1925, and full professor in 1930. He excelled especially in the development of radio.

Gustav Jäger (April 6, 1865 Krásná by Aš (Schönbach by Asch) in Bohemia-January 21, 1938 Vienna) studied physics at the University of Vienna with his fellow Bohemian Joseph Loschmidt, Victor Lang and Jožef Stefan to get his Ph.D. in 1888. From 1891 he was a lecturer at the Institute of Theoretical Physics and assistant to Stefan and after his death to Ludwig Boltzmann. From 1897 he was an associate professor of theoretical physics in Vienna. In 1905 he became a full professor at the Technical University of Vienna, where he was the rector in 1915/16. Since 1918, he was a member of the board of the Institute of Theoretical Physics at the University of Vienna and the Management Board of the 2nd Physics Institute of the University since 1920. He retired in 1934.

After his doctorate, Vidmar worked in industry first in Graz and then in Budapest as assistant to the chess player Ottó Titusz Bláthy who was a leading Hungarian electrical engineer. In 1882, Blathy completed his studies in Vienna, but as an electrical engineer he formed himself in the class of Károly Zipernowsky (1853 Vienna - 1942 Budapest).

Blathy was the co-inventor of the transformer and other AC technologies. With Zipernowsky, Blathy completed his studies in Budapest. During his Technical University years, he gave many lectures on the electronics. In 1878 Zipernowsky graduated from the Hungarian Palatine Joseph Technical University in Budapest and became a professor at the university in 1893. In 1878, the Ganz factory's managing director András Mechwart entrusted him with organizing their electricity department. Mechwart (December 6th, 1834 Schweinfurt-June 14th, 1907 Budapest) studied at the Augsburg Polytechnic with a fellowship granted by his

²⁵⁵⁷ Vidmar, 1964, *Memories* 1: 212.

hometown and obtained his diploma in engineering in 1855. In 1859, he joined Ábrahám Ganz iron foundry in Buda.

In 1925, Vidmar lectured on the theoretical basics of electrical engineering at the Technical Faculty in Ljubljana. On the chair of theory of electrical machines Vidmar was replaced by V. Bedjanič, who independently taught in 1945. M. Papler later became Vidmar's assistant lecturer focused on the transmission of electricity.²⁵⁵⁸

18.5.18 *Tesla and Bošković*

We all know the popular photograph showing the reader Tesla in Faraday cage, with a lot of lightning all over the place. However, it was only recently discovered that he reads - Bošković's Theory of the Philosophy of Nature.²⁵⁵⁹ In any case, Tesla was especially impressed by Bošković, as he himself defended Bošković's physics with one single force.

After the publication of R. Clausius's virial theorem in 1870 the existence of both opposing forces in the molecule was already quite unambiguous, although, for example, Lavtar (1873) and Sekulić (1874) still tried to explain the repulsions only by the attraction. In 1865, Robida probably also backed uniqueness of Newtonian attraction in his defense of Šubic against Krönig's criticism. August Karl Krönig chose Šubic as an example of a theory opposite to his own. He read only the introduction and the first chapter of Šubic's book, because his persistent pain in eyes has prevented him from reading for almost three years.²⁵⁶⁰ On 24 February 1864, Krönig wrote a critique a year and a half after the publication of Šubic's book in the summer of 1862. Šubic seemed to him like Lavtar (1873) or Sekulić (1874), who tried to derive all physical phenomena from the effects of a single gravity force.

Lavtar's idea was like Ampère's theory of electric current vortex in molecules resembling Bošković, although Lavtar did not specifically emphasize this. Ampère's wave theory of heat from 1835-1836 was upgraded by the discoverer of the sputtering of metals William Robert Grove (* 1811; † 1896) in 1842/43. It was accepted by the

²⁵⁵⁸ Vidmar, 1964, 1: 241-242.

²⁵⁵⁹ Zorić, 2010, 10; Civrić, 2011, 51.

²⁵⁶⁰ Krönig, 1864, 305.

Viennese university professor of physics and the president of the academy Andreas Baumgartner (* 1793; † 1865), followed by Robida and Sekulić. Tesla's professor Sekulić also added electromagnetism²⁵⁶¹ to his wave theories at the same time as Maxwell, which stimulated Tesla's love for the transfer of waves through a vacuum: the path through the invisible brought the light forth.



Figure 18-62: Tesla reads Bošković's Theory in New York in front of his laboratory full of sparks of a high-frequency transformer.

The couple (the twin forces, dual, the twins) were the fundamental principle on which Tesla's professor Sekulić built his physics of atoms and molecules²⁵⁶² and outlined his vision of the vacuum of his recent graduate Tesla.

Sekulić considered that all influences on the body can be described by the force of the resultant in the translation or by a pair of forces (couple) in rotation.

18.5.19 *Tesla and Pupin*

Tesla and his two-years senior Mihajlo Pupin (* 1854; † 1935) arrived in the USA from their homeland from the same Orthodox environment of

²⁵⁶¹ Šešić, 1996, 58-59.

²⁵⁶² Sekulić, 1874, 112-119.

the Military Border during the Military Krajina painful fateful abolition. Tesla's Military Krajina has Croatian=Catholic majority, while in Pupin's Vojvodina part of Military Krajina the Orthodox religious practices were prevailing. Tesla had full support in his Slavic inspired higher real school in Rakovac, while Pupin got much more problems with German professors at the higher real school in Pančevo, where he was defended by the physicist Simon Kos who grew up in Blejski Kot, and the Orthodox Priest Basil Živković, a relative of Tesla's catechetic Nikolaus Živković. Pupin's professor of geometric rendering and mechanics Karl Klekler (* 1842 Wiener Neustadt; † after 1901) was employed on 30 December 1865. According to his publications like *Die Methoden Der Darstellenden Geometrie* in 1877, Klekler was similarly remarkably educated as Tesla's professor Sekulić; this is not particularly surprising given that professors in the Military Krajina were better paid and better equipped. Similar as Sekulić, Klekler also wrote about kinetic theory but with much more support. On the other hand, Klekler, as a German and Habsburg fan, did not like Pupin's Serbian nationalism, while Tesla did not have these problems in Rakovac. Klekler published numerous geometric books. He lectured at the Higher School in Pančevo between 1869-1872; then he was a professor of mathematics at the Naval Academy in Rijeka until 1878. In 1874 he first taught the basics of mathematics, with the assistance of the Ukrainian vacuum researcher Puluj. Tesla's friend Puluj later became the rector of the Prague Polytechnic and the dean of the electrotechnical faculty.

In 1877 in Rijeka Klekler lectured on higher mathematics, while Peter Salcher taught mechanics with physics. For Ernst Mach designs, Salcher photographed waves of the supersonic speed missiles in the Adriatic Sea by Rijeka. Klekler continued his schooling career by the end of the century as director of the higher real school in Linz and then in the 7th district of Vienna. Pupin later remembered his professors the Slovene Kos and Živković, but disliked Klekler. Similarly, Tesla denied or at last forgot the merits of his professor Löffler from Rakovac real school.

In the meantime, Tesla felt some ethnic intolerance in Graz; with Pupin, they preferred studying at the Technical High School in the Slavic-friendly Prague even if they were not successful there.

When just the pieces of bread remained, they, once again one after another, legendary with a few cents in their pockets, sailed to the promised land called America. Pupin was more successful on the academic side and even on the long run with his moneymaking. Of course, the modern popularity of Tesla is inappropriately larger than Pupin's, although they had both a few notable inventions. Pupin arranged a pension from the Yugoslav king for Pupin's two years younger Tesla, but in professional and business terms, Pupin and Tesla were often in quarrels. They were probably just too much similar Orthodox guys with their great egos, and even the huge America was not broad enough for both. Just like in the old Serbian proverb: two hens could not be in the same chickenyard.

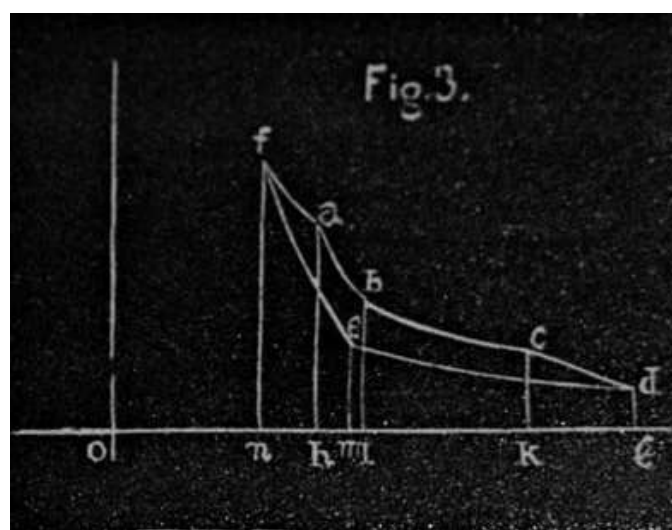

Figure 18-63: Klekler's sketch of the Carnot-Clapeyron's circular process by which he did not sufficiently impress his fifteen years old pupil Pupin (Klekler, 1869, 13).

They both loved Yugoslavia, but their approach was different. Pupin helped Tesla's few weeks younger coeval Thomas Woodrow Wilson (1856-1924) to define Yugoslavian borders after WWI also for Simon Kos' Blejski Kot included, while Tesla was in knockdown in those times after his bankruptcy of 1916. Pupin even helped Tesla to get a pension of Yugoslav king, but none of those enabled a mutual love between Pupin and Tesla who were far too equal to respect each other. After 1934, the annual pension of \$ 7500 of the Yugoslav king received by the Yugoslav general consul in Chicago up to 1929 and in New York in 1929-1936 Radoje Janković (1879 Čačak-1943) helped a lot, but Westinghouse electric & manufacturing company paying Tesla's New

Yorker hotel bills and monthly \$ 125 as Tesla's informal consultancy was even more welcome after 1934. Finally, Radoje Janković's wife Natalija Kalmić married in 1918 in Samara fulfilled the wish of Pupin's daughter Vida and arranged a half of hour deathbed meeting of reconciliation between freemason Pupin and Tesla in March 1935.

18.5.20 Importance of Maribor Affairs for Tesla's Success

After Maribor and other challenges, Tesla dropped out of his studies; he was no longer teachable, at least not in official school systems, and in fact he knew more than others. Tesla's path was not unusual at all, as it is common whenever any challenging newly advanced technologies overrun the classroom lectures on their own topics. The students soon discover that they know more than their professors in their narrowly focused fields and – dropout. Tesla's electrotechnical challenges repeat today with web technologies of dropout students like Americans Bill Gates (* 1955), Mark Zuckerberg (* 1984), Matt Mullenweg (* 1984), the Syrian-American Steve Jobs (1955-2011), Iranian-American Arash Ferdowsi (* 1985) or the Swede Daniel Ek (* 1983).

Undoubtedly, Tesla was not self-taught, since he studied the most advanced vacuum techniques and electrical engineering in Graz. On the other hand, the vision of Sekulić's rotating sphere with Bošković's uniform force grabbed Tesla's view of the world, which he never allowed to change.

Later, on May 24, 1892, Tesla personally gave advice to the mayor of Zagreb and his colleagues about public electric lighting with light bulbs in Zagreb.²⁵⁶³ The later mayor of Zagreb Franjo Hanaman (* 1878; † 1941) was at that time a student of a real gymnasium in Zemun until graduation in 1895, and eight years later he began to invent incandescent lamps under Tesla's influence in Vienna. During his visit to Zagreb, Tesla almost certainly studied the situation in neighboring Maribor. Despite the interest and progress of the then electro-technic of Maribor in Tesla's time, he was unable to stay there. Of course, we can only regret it, but it is probably too late.

In 1904, Tesla gained his honorable Ph.D. in Vienna,²⁵⁶⁴ later also in Zagreb, Graz and in many other places. Even more witty, Edison got his honorary doctorates without any schools. Edison better mastered the writing of journalists, but his engineering method was, at least initially, only an experiment and a repeated correction of its error, while Tesla bet on his thought experiments. After July 1904, the friendly John Pierpont Morgan (* 1837; † 1913) suspended support for Tesla's life-long project Wardencllyffe Tower which lasted in 1901-1917, as it seemed that the inventor intended to export US electric power to the whole lot of world for free. Tesla then began to intertwine the legend around his own personality and achievements, although he was relatively modest before the tragedy. As the stream of Tesla's electrotechnical novelties dried up, his reputation is upgrading up to this day.²⁵⁶⁵

Another American Morgan (namely Avigdor M. Vic Morgan) later stopped his initial supporting of Codelli's cathode ray tube television patents in the United States. A coincidence of fatal South Slavic connections with Welsh Morgan family?

18.5.21 Nikola Tesla for Healthy Eating and Free Energy

Nikola Tesla spoke a lot and wrote again and again about proper healthy diet and the experiments to accommodate the hungry part of the world's population. To reach that goal, Nikola Tesla wanted to provide the world with free energy by awakening planetary resonances, later named after German physicist Winfried Otto Schumann (1888 Tubingen-1974 Munich). Nikola Tesla would then empty them to another energy-needy place. In Tesla's mind mistreated in Maribor, an unusual physical intuition has grown up, which enabled him to perceive the resonances of the Earth's atmosphere between the conductive surface and the lower layer of the ionosphere during the Tesla's sparking and flashing of Colorado Springs, which Schumann more accurately calculated after Tesla's death in 1952.

²⁵⁶⁴ Mrkić, 2004, 45.

²⁵⁶⁵ Pištalo, 2009, 348.

²⁵⁶³ Dadić, 2004, 12.

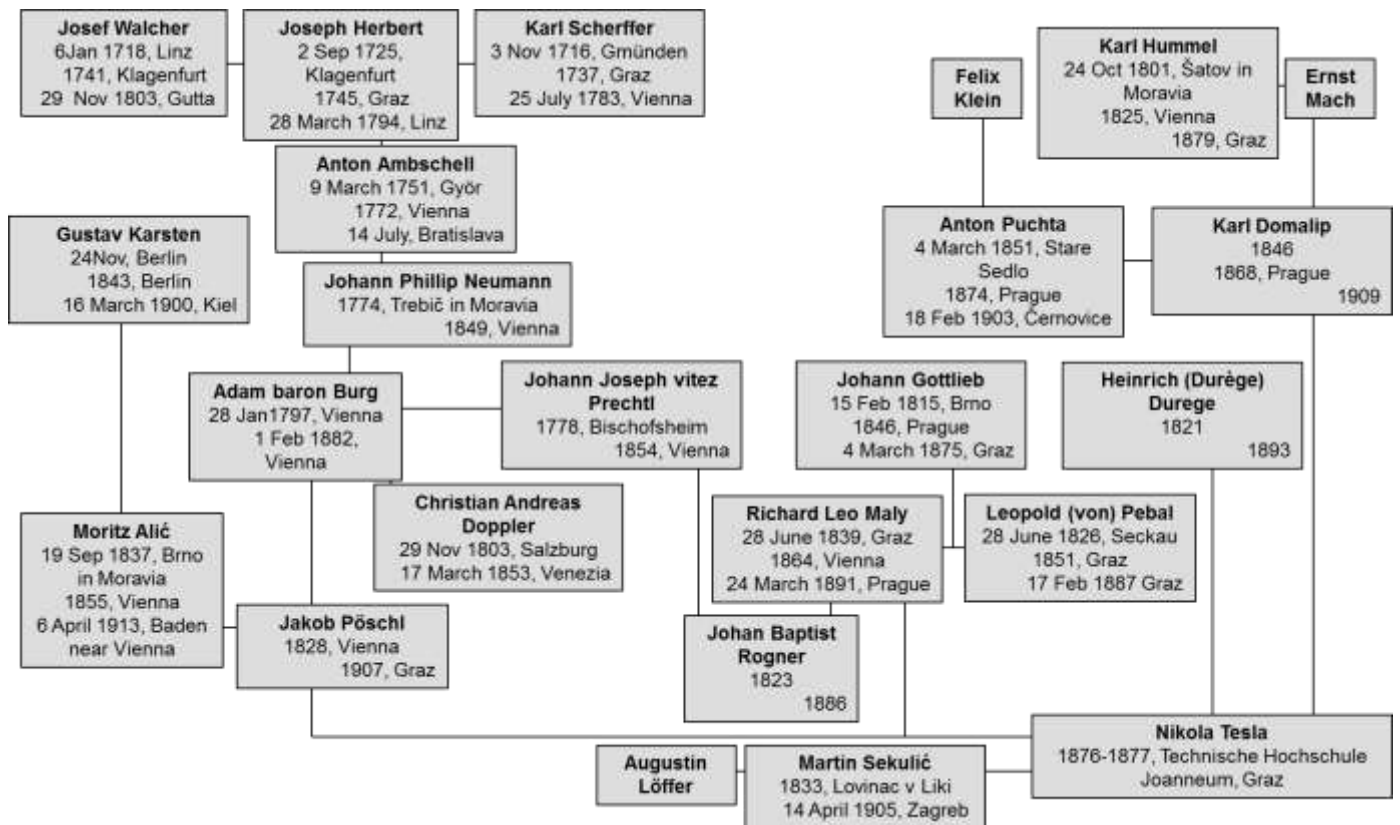

Figure 18-64: Tesla's academic ancestors down from the collaborator of Bošković, whose book he calmly reads under the sparkling in Faraday cage. The picture shows Tesla's academic ancestors among professors of mathematical and physical subjects with data about their studies. They include the researchers of vacuum noted in this book including Mach, Neumann, Ambschell, Gruber, Robida and Stefan.

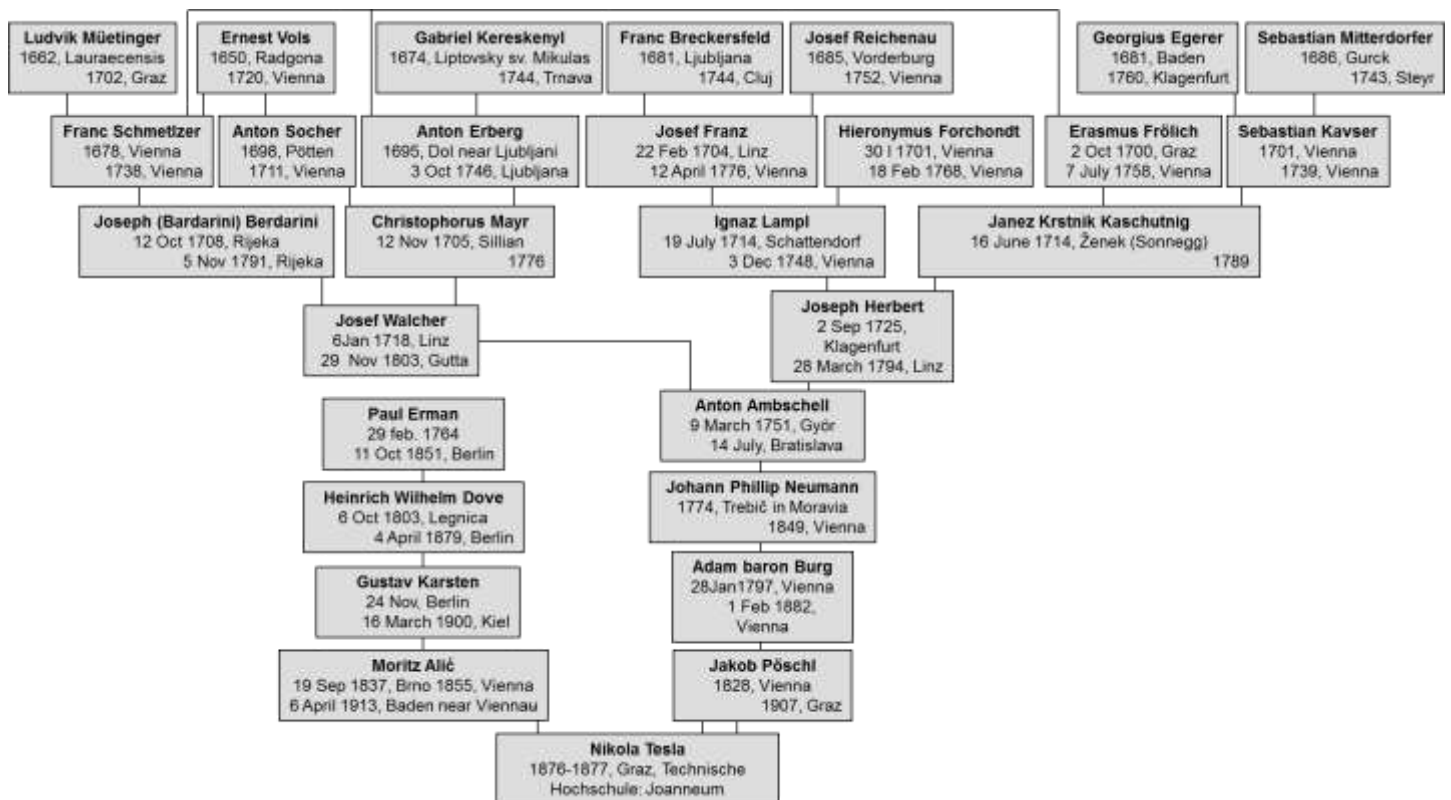

Figure 18-65: Tesla's academic ancestors according to his studies in Graz with specially marked Slovenians

Among Tesla's many undoubtedly interesting and numerous domains of crazy ideas, it is difficult to choose the most imaginative, just as it is difficult to choose the best record of many other guys. Tesla's unique surplus is almost certainly a planetary resonator, a tower in Wardenclyffe near the New York City metropolis. Tesla's extraordinary deep intuition had realized there: during the measurements of the flash frequencies in Colorado Springs not far from Buffalo Bill's grave, Tesla recognized the basic frequency of the earth electromagnetic oscillator, which was later calculated by Winfried Otto Schumann more precisely with better mathematical approaches after Schumann spent a long time in Krupp's town of Berndorf not far from the metropolis of Vienna. God knows, if Schumann was not there to meet a Slovenian literati Ivan Cankar who was not exactly the adversary of Krupp's cannons. Tesla was also not particularly enthusiastic about them; perhaps Schumann anticipated a promising discovery already in Berndorf? Tesla understood the operation of the earth's oscillator. In a megalomaniac wish, Tesla wanted to stimulate the resonator in planetary dimensions and draw energy from it for anywhere on the surface of the planet. It's really a genuine idea with which Tesla overcame himself. Because Tesla told G. Westinghouse and J.P. Morgan about insubstantial assurances that he would not be able to put counters on his tower and reimburse the customers' consumed electricity with their paid bills, those magnates stopped their support. More likely, Tesla increased his original budget to an impossible height, just as Gabriel Gruber did with a canal in Ljubljana or the advocates of the Texas Superconductive Super Collider did in USA. In the same way in 1993, the opponents of the Republican Lonely Texas Stars helped their European rivals who discovered the predicted "God particle" of Scottish Englishman Peter Higgs at CERN's Great Hadron's Collider a decade after the abandoned Texas project. If the Russians or any others on the opposite side of the Great Blue Water called Atlantic really could erect Tesla's Tower, that would probably mean that Donald Trump, with his Zaslavje bride, made it too late for America to make Great Again, Slovenian aircraft carrier up or down.

So, we do not know for sure whether Tesla's idea is quite possible, but its undoubtedly worth a try as it is so brilliant. It is not worth looking for an all-

encompassing predecessor of later inventions and discoveries in Tesla, for even the story of Tesla's X-ray does not hold water. It was mainly the question of names: many experimented with invisible rays, but only the Nobel prize-winning Roentgen picked up the cream after hitting his nail on the head by pulling the right strings of the scientific networks. In 1897 before New York academy of science, Tesla in his paper *The Streams of Lenard and Roentgen and Novel Apparatus for Production* in fact claimed that Philipp Lenard was Roentgen's equal, but after Lenard's racist stances against Einstein Tesla could have changed his mind. Race is the child of racism not the father.²⁵⁶⁶ Tesla distinguished between Lenard's rays later called electrons after J. J. Thomson measurements of that same year 1897, and Roentgen's rays soon nicknamed X-rays. Tesla suggested that all of them were not transversal as most of the researchers though because Tesla hoped that some longitudinal waves are also involved. The basic difference among that bunch of new rays and waves discovered in Fin de Siècle were their behaviours in magnetic field which curved just the orbits of charged particles, although Tesla also erroneously claimed that he deflected the Roentgen's rays with a magnet which made them similar if not equal to Lenard's rays.

In April 22 and August 12, 1896 issues of the *Electrical Review* Tesla was more precise and narrated that only Lenard's rays could be deflected in a magnetic field. In his cathode ray tube, Tesla used the electrodes of platinum and of his bellowed aluminium. M. Pupin also spoke about the induction coils for the generation of Roentgen's rays before Tesla did, but Pupin's address received much less attention than Tesla's which only raised the competition between both Orthodox guys in front of the *New York academy of science* on 5th and 6th April 1897.²⁵⁶⁷

²⁵⁶⁶ Leland I. Andreson (ed.) 1992, *Lecture before New York academy of science: The Streams of Lenard and Roentgen and Novel Apparatus for Production* 6. 4. 1897, Colorado: Twenty First Century Books; Tesla on the Hurtful Actions of Lenard and Roentgen, *Electrical Review* (N. Y.), May 5, 1897; Tesla on the Source of Roentgen Rays and the Practical Construction and Safe Operation of Lenard Tubes, *Electrical Review* (N. Y.), May/August 11, 1897; Ta-Nehisi Coates (* 1975 Baltimore). 2015. *Between the World and Me*. New York: Spiegel & Grau, 7.

²⁵⁶⁷ Leland I. Andreson (ed.) 1992, *Lecture before New York academy of science: The Streams of Lenard and Roentgen and Novel Apparatus for Production* 6. 4. 1897, Colorado: Twenty First Century Books, 20, 22-23, 99, 100, 114, 115.

Before his Wardenclyffe tower tragic collapse, Tesla used to be a winner in those duels with his competitors. He loved to enter the courtrooms accompanied with his lawyers, tall and self-confident so long as his Wardenclyffe tower staid erected. Besides foreigners like Marconi and Ferraris, Tesla also had to compete with his USA rivals like Elihu Thomson (1853-1937). Elihu Thomson and Edison considered Roentgen's rays as a danger while Tesla even praised the ozone produced by the Roentgen's rays as a benefit for his and his assistants' health and coughing. On the other hand. Lenard's rays could be harmful for the human skin. So, Tesla made few advices for the physicians who used the cathode ray tubes.²⁵⁶⁸

Westinghouse later repaid at least the Slovenes and Croatians for his trickery at the expense of Tesla: Westinghouse company generously established the combined Slovenian-Croatian nuclear energy power plant in Krško by Sava River. The local nuclear energy power plants began for the Slovenians somewhat earlier in Podgorica – which was not the Montenegro Podgorica but Podgorica near Ljubljana, in the then municipality of Bežigrad, which is today's Dol by Sava river municipality. Westinghouse's Slovenian-Croatian nuclear energy power plant in Krško by Sava River in fact gives the electricity to Tesla's native Lika.

Tesla's vision announced as food for everybody flowered until Tesla's "friend" George Westinghouse changed his mind during the construction of a tower in Wardenclyffe on Long Island. George Westinghouse and Morgan were worried about the location of charging meters for their consumers. When tearful Tesla confessed the obvious truth that the counters of his resonances could not be easily charged or glued, the project - and cash inflows - was at its dead end. Another point against Tesla's project was Marconi's disloyal competition and Tesla's hasty proposal for replacing just-introduced alternating-current networks' wires with wireless. Tesla won the battle of currents against Edison and now he wanted to win another battle against his own child called alternative currents' transfer by the wires. It was all too soon for a change, but Tesla was simply not a guy to wait like Gauss did in his time with his

²⁵⁶⁸ Leland I. Andreson (ed.) 1992, *Lecture before New York academy of science: The Streams of Lenard and Roentgen and Novel Apparatus for Production* 6. 4. 1897, Colorado: Twenty First Century Books, 26-27, 84, 107.

non-Euclidean geometry. The surprised businessmen even complained: "Why didn't Tesla introduce the wireless energy transfer in the first places, but he allowed us to spend all that huge money on wires which now Tesla do not need any more?"

On the other hand, Tesla was extremely proud of his slogans of a healthy life, and he liked thejournalists to advertise Tesla's cooking recipes, based primarily on the moderation in nutrition, where Tesla flirted with vegetarianism through the wisdom of the deceased mother of Tesla. Certainly, Georgina nicknamed Đuka Tesla cooked meat as all other mothers do in predominantly shepherds' society of Lika, but she was a wise person anyway.

Tesla initiated something like third major quarrel among the researchers of electricity. The initial dispute between B. Franklin and Nollet's electrotechnics of the shape of lightning conductors barely ceased when Volta's and Galvani's adherents shifted a new one focussed on the source of electrical power. Tesla's dispute with Edison was, above all, a repetition of old problems in which profitability intertwined with knowledge.

18.6 Vacuum of the President's Uncle

The brother of Melania's father-in-law was a central figure in FBI examinations of Nikola Tesla's high voltage designs left as Tesla's heritage. John Trump was the leader of Van de Graaff's high voltage physics which used the different techniques to reach the same goals as Tesla's Coil, eventually without the Tesla's central ideas of wireless distribution of energy. The brother of Melania's father-in-law publicly announced his disappointment with Tesla's Death Rays as a special case of Tesla's wireless distribution of energy. The brother of Melania's father-in-law stated that Tesla made no progress in last decade and a half, that is after early 1928 when the brother of Melania's father-in-law John Trump was undergraduate student in Polytechnic Institute of Brooklyn not far from Tesla's hotel. Did John spoke the truth, or he used Tesla's achievements for his own business like so many others?

During the atomic race in the 1930s, the researchers knew that the lightning was carrying the energies up to 15 MeV, which was much more than they could produce in laboratories to accelerate the particles. Tesla's Colorado Springs might have been the unique exception. That's why Arno A. Brasch (* 1910 Berlin; † 1963 New York City), Nernst PhD student father of Soviet atomic bombs Fritz Lange (* 1899 Berlin; † 1987 Berlin) and Kurt Urban (1904–1928) made experiments on Mount Generoso in Switzerland 145 km north of Volta's native Como. Between the two rocks they placed a metal mesh on which a positive charge was collected. With a particularly strong bombarding, a spark, 5 m long, corresponding to 10 MeV energy could be obtained. However, during the experiment at ungenerous Generoso mountain, Urban suffered a fatal shock, as did Richman almost two centuries earlier. During the years 1919 and 1932, accelerators were built using high-voltage generators, which directly speeded up the charged particles in a fixed electric field. The development of such devices was crowned by the electrostatic Van de Graaff generator in 1931 and the cascade generators of Cockcroft and Walton a year later.

Robert Van de Graaff (1901-1967) from Alabama improved the electrophorus electrostatic generator. He used the idea of a transformer to increase voltage, and thus followed the old Guericke's ideas from 1671. The electrostatic charge generator with a conveyor belt was first described by Righi's rearranging of an older W. Thomson idea of a generator using charged droplets of water in 1872 and 1890. K. T. Compton from the Physics Department of the University of Princeton backed the idea of his colleague Van de Graaff. Thus, in 1929, the first model was created. In two years, Van de Graaff reached a 1.5 MV voltage and reported enthusiastically to the American Physical Society. In 1932, Van de Graaff moved to MIT, where he began working with stronger generators with Compton's support. At the same time, Merle A. Tuve, Amundsen's North pole expedition aviation assistant Odd Dahl (1898 Drammen in Norway–1994 Norway) and Lawrence Hafstad built the first usable Van de Graaff electrostatic accelerator at Carnegie Institution in Washington (Figure 18-67).²⁵⁶⁹ Among the first, they surpassed the magic 1 MeV of energy needed to penetrate the nucleus of the atom.

²⁵⁶⁹ Livingston, Blewett, 1962, 31–33.

In 1933, Van de Graaff in MIT assembled a "Grosse Bertha" device from two parts weighting 16 tons, altogether 32-ton. The accelerator was named after the German cannon of the First World War. A carefully dented aluminium sphere of diameter 5 meters and a thickness of 6 mm was placed on top of an insulated cylinder with a diameter of 7.5 m and a height of 2 m. In the hollow cylinder, a movable silk belt pulley was transferred from the silk to transfer the charge from the high voltage rectifier. The spark could be discharged at a voltage of 7 MV. Later, Westinghouse's electric company, on the same principles, set up a huge pear-shaped device for breaking atoms in the suburbs of Pittsburgh.

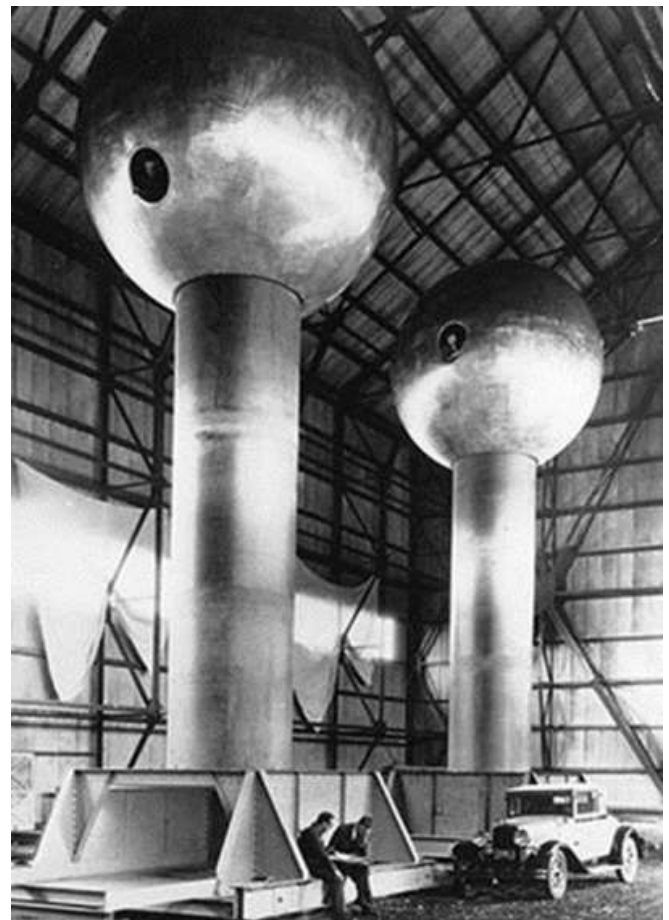

Figure 18-66: 12 m high Van de Graaff generator at MIT, today at the Boston Museum of Science.

After graduation at Polytechnic Institute of Brooklyn in 1929, John Trump got his M.S. in physics with Tesla's antagonist Mihajlo Pupin in Columbia University of New York in 1931. Afterwards, John Trump left his native New York to join the professor Robert J. Van de Graaff in MIT where he defended his Ph.D. entitled Vacuum electrostatic engineering acknowledging Van's experimental work, visionary starting vacuum

electrostatic engineering, research technique, ideas, and inspiration in late 1933. John George Trump received his doctorate in electrical engineering from MIT in the decisive year when Hitler took over the power in 1933. Tesla constructed his own Van de Graaff in 1934. The former Tesla-related Westinghouse company developed the similar device in a suburb of Pittsburgh for civil nuclear research in 1937, and seventeen years later Edvard Cilenšek in Ljubljana designed his own Van de Graaff in Ljubljana institute later named IJS, modelled on Trump-Graaff's company products. They were developed after the WWII by Trump's collaborator in Royal Air Force Radar Development Denis M. Robinson (1907-1994) serving as cofounder of High Voltage Engineering Corporation (MA) in 1946, chief operational officer (1946-1970) and chairman of the board together with Trump after 1970. Trump was a technical director of their corporation from 1970 to 1980, and senior consultant afterwards.

Robinson received his doctorate in electrical engineering at the University of London in 1929 before joining MIT for two years. He worked under the supervisions of the Dean of the Department of Engineering at MIT, appointed in 1932, later chairman of the National Defense Research Committee and the initiator of the Manhattan project the Freeman Vannevar Bush (March 11, 1890 Everett-June 28, 1974 Belmont). At MIT, Robinson collaborated with Van de Graaff and Trump. Robinson then proceeded to work for the industry until Charles Percy baron Snow redirected him to scientific work in 1939; two decades later, Snow conceived his famous idea of an insurmountable gulf between technical and humanistic culture. Robinson, along with Trump, developed a radar in a project led by James Watt's descendant Wattson-Watt. Thus, Robinson and Trump came together for three consecutive times in their joint work in several areas of vacuum technique. In July 1945, in the highly popular *The Atlantic Monthly* magazine, V. Bush published a noteworthy record *As We May Think*, which was as influential as Emerson's message to the American scholars in 1837. Bush promised the development of knowledge, and not only power in the future. He discussed the achievements of George Mendel, Leibniz and Babbage in the pioneering development of computers. Finally, he focused on the development of photography and computers; with a newly coined term memex, he

marked the storage of books and other knowledge resources in memory.

With the support of Natick Laboratory and the Army Quartermaster Corps Trump and his associates developed the methods for the preservation of food by high voltage radiations while experimenting on bactericidal and viricidal effects. Until 1950 almost all radiation therapy relied on the X-rays produced by collisions of high-voltage electron beam with the Rutherford's gold leaves in vacuum, but Trump, Van de Graaff and Robert W. Cloud in their paper promoted the uses of different matter-penetrating directed high voltage-electrons in 1940.²⁵⁷⁰

John Trump worked as Van's research associate in 1933, assistant professor in 1936 full professor from 1952 to 1973, and professor emeritus from 1973 to 1980. John developed the insulation of super-high voltages in vacuum and compressed gases for nuclear physics, the biological applications of high voltage megavolt radiations for medicinal cancer treatment, the food preservation by electron beam, and the 2 Megavolt ecological treatment of dirt in sewage or sludge in 1976. Trump's group with grants from Godfrey M. Hyams (1859–1927) foundation built the air-insulated megavolt generator for Huntington Memorial Hospital for deep tumour treatments in 1937 which was not in its best during the wet days. In 1938 Trump used the same grants to design 1.25 megavolt generator insulated with compressed gas for George Robert White Hospital of the Massachusetts General Hospital, and 1.75 megavolt generator for the American Oncological Hospital of Philadelphia which was used for Manhattan Bombing Project.

After Tesla's death in New Yorker Hotel on January 7, 1943, the FBI seized his heritage with documents and hired the son of German emigrant MIT professor of engineering high voltage electric engineer John George Trump (1907-1985) of OSRD to investigate Tesla's heritage and find out how deadly were those rays. The president of MIT Karl Taylor Compton (1887-1954) hired Trump for

²⁵⁷⁰ Trump, J.G., Cloud, R.W. Physical characteristics of supervoltage roentgen rays. *Am. J. Roentgenol.* 1940, 44: 615; Trump JG, van de Graaff RJ, Cloud RW. Cathode rays for radiation therapy. *Am J Roentgenol Radium Ther Nucl Med (The American Journal of Roentgenology Radium Therapy and Nuclear Medicine)* 1940, 43: 728–734.

the checking of Tesla's heritage. In May 1941 the newly established OSRD was headed by Vannevar Bush while John George Trump was supposed to investigate Tesla's heritage and find out how deadly were those Tesla's rays. In those times Trump worked on radar as secretary of Microwave Committee of British branch of MIT Radiation Lab. In 1944 because Brits proved to know more about radar, Trump became the director of the laboratory while working directly with the General Eisenhower Military Command. At the liberation of Paris Trump rode in with Eisenhower.²⁵⁷¹

Trump examined Tesla's scientific papers. The review was performed at warehouse of Manhattan Storage and Warehouse Company. Apart from Trump, there were present Willis George from the Maritime Intelligence Office, a naval officer chief yeoman warehouse manager of United States Navy Reserve Edward R. Palmer, and his assistant chief yeoman John J. Corbett. Trump later stated that no large amount of Tesla's stuff had been inspected, which was stored in the basement of the New Yorker hotel full ten years before his death, or any other Tesla writings other than those he had when he died. It should be noted that Tesla's scientific reputation was in decline while many challenged his inventions, robotization and alternating current. In addition, Trump was a very busy man while the FBI barely managed to find enough people for their many investigations into possible sabotage. "As a result of the examinations," wrote Dr. Trump, "It is my considered opinion that among his papers and in his property Dr. Tesla has no such scientific notes, description of unpublished methods, unpatented devices or ready-made devices that might have some more relevance for this land or could pose a risk when they fall into enemy hands. So, I do not see any technical or military reasons why his property should still be kept confiscated."

He added: "For our needs, however, a bunch of different kinds of materials has been prepared... It covers typical and almost all the ideas he has dealt with over the past years." Trump got Tesla's papers numbered and briefly described in the attachment of this letter.

In conclusion, Trump wrote: "It should not hurt the reputation of distinguished engineers and

scientists, whose concrete contributions to electrical engineering were made at the beginning of this century, if I report that his thoughts and endeavors over the last fifteen years were primarily speculative, philosophical, and a bit promotional nature - often involved in the production of wireless energy transfer - but without involving new, healthy and viable methods for achieving such results."

It seems that the documents (for which Trump wrote numberings and abbreviations with descriptions) were copied by photostatic images (the former way of copying to a photopaper with light) or microfilmed by a naval officer, while the original documents were kept in the warehouse and subsequently transferred to Yugoslavia. No detected threatening foreign assets were subject to the provisions of the Law on Trade with the Enemy. That's why Tesla's papers, personal documents, drawings and more were handed over to disposing of his nephew Kosanović who governed his legacy in February 1943.

In addition to the report, Trump listed the following short descriptions of Tesla's papers:

a) Art of Telegeodynamics, or Art of Producing Terrestrial Motions at Distance (in connection with earlier Tesla's tower) —This document, in the form of a letter dated June 12, 1940, to the Westinghouse Electric & Manufacturing Co., proposes a method for the transmission of large amounts of power over vast distances by means of mechanical vibrations of the earth's crust. The source of power is a mechanical or electromechanical device bolted to some rocky protuberance and imparting power at a resonance frequency of the earth's crust. The proposed scheme appears to be completely visionary and unworkable. Westinghouse's reply indicates their polite rejection...

b) "New Art of Projecting Concentrated Non-Dispersive Energy through Natural Media—This undated document by Tesla describes an electrostatic method of producing very high voltages and capable of very great power. This generator is used to accelerate charged particles, presumably electrons. Such a beam of high-energy electrons passing through air is the 'concentrated nondispersive' means by which energy is transmitted through natural media. As a component

²⁵⁷¹ Smullin, Louis. 1989. John George Trump (ed. National Academy of Engineering). *Memorial Tributes: National Academy of Engineering*, 3: 333-335.

of this apparatus there is described an open-ended vacuum tube within which the electrons are first accelerated.

“The proposed scheme bears some relation to present means for producing high-energy cathode rays by the cooperative use of a high-voltage electrostatic generator and an evacuated electron acceleration tube. It is well known, however, that such devices, while of scientific and medical interest, are incapable of the transmission of large amounts of power in nondispersed beams over long distances. Tesla’s disclosures in this memorandum would not enable the construction of workable combinations of generator and tube even of limited power, though the general elements of such a combination are succinctly described (Trump was certainly not a fan o Tesla’s tower).

c) “A Method of Producing Powerful Radiations— an undated memorandum in Tesla’s handwriting describing ‘a new process of generating powerful rays or radiations.’ This memorandum reviews the works of Lenard and Crookes, describes Tesla’s work on the production of high voltages, and finally in the last paragraph gives the only description of the invention contained in the memorandum. As Tesla briefly stated, his new simplified process of generating powerful rays consists in creating through the medium of a high-speed jet of suitable fluid a vacuous space around a terminal of a circuit and supplying the same with currents of the required tension and volume.”

Long after he examined Tesla’s, Trump reported in a letter to a friend about his inspection at the Governor Clinton hotel. He examined the device stored in his basement vault, probably the same box remembered by the messenger boy in Tesla’s room who was not allowed to touch it.

A quote from M. Cheney:²⁵⁷² "Tesla warned the hotel management that this device is actually a secret weapon," wrote Dr. Trump “and could explode if opened by an unauthorized person. That is why immediately, as soon as the basement opened and showed where the box was located, the manager and the entire staff rushed out the room quickly. Federal agents, who came accompanied by dr. J. Trump, also retreated to the bottom of the cellar, allegedly to facilitate access to the box. The box was wrapped in hard brown paper and the

entire length knitted with ribbons. Trump got the sole distinction of opening the parcel.



Figure 18-67: New Yorker Trump (Right) and the director of MIT Radiation Lab Lee DuBridge (1901-1994) from Indiana, enjoying Paris in their military vehicle

Later, J. Trump remembered how he hesitated himself, thinking that it was really a wonderful time and wondering why he was not out there anymore. He put the package on the table and, checking his own bravery, began careful unbounding of box with his pocketknife. He removed the wrapper. Inside there was just another nicely decorated wooden box, lined with a zipper on the lid. He had to accumulate all the remaining strength and courage to finally release the zipper and lift the lid... He bravely raised the hinged lid...

Inside, there was a ten-year old device for measuring Wheatstone bridge resistance, which they used in every little better electro-laboratory before the turn of the century! It was, therefore, a very common and standard measuring instrument... ohmmeter."

Why did Tesla put the staff and management of that hotel in anxiety and horror with such an innocent object for many years? Perhaps he used that old Serbian trick to manage that his hotel bills were paid for him as he was believing that the hotels he lived in were honoured by his presences; because they had him as a guest they should simply write off his bills. So, he found himself insulted by the fact that the hotel Governor Clinton insisted to settle his unpaid bill of \$ 400.²⁵⁷³

²⁵⁷² Cheney, (*Tesla – Man Out of Time*, New York, 1979).

²⁵⁷³ J. Moser: *The pursuit of Tesla's missing manuscripts. Did Tesla find the rays of death? History and philosophy of*

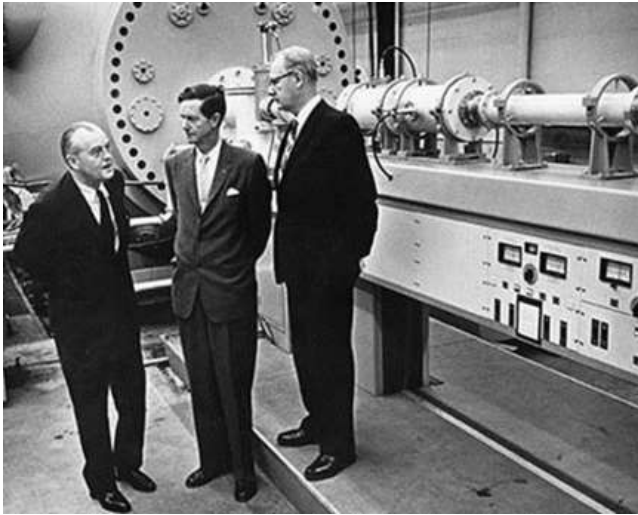

Figure 18-68: Trump on the right, Graaff on the left and Robinson in between

not officially present in his FBI report. After the war John George Trump joined Van de Graaff in producing their joint high voltage electrostatic generators of the types like Tesla's Wardencllyffe tower except that Van de Graaff used the largescale triboelectric effect known for two centuries, while Tesla's coil used recently acknowledged transformer based on resonances. It was designed only in 1891. While Van de Graaff's high voltage electrostatic generators are still widely used, Tesla was the only serious user of his own coil which is now almost solely needed just for detection of leaks of high vacuum systems or for fun and entertainments. Tesla's coil is presently primarily an interesting toy like cathode ray tube was in the first decade after its invention in Bonn in mid-19th century. But cathode ray tube got its industrial use of Ferdinand Braun before the turn of century called Fin de Siècle, while Tesla's coil is waiting for its industrial use already twice as long.

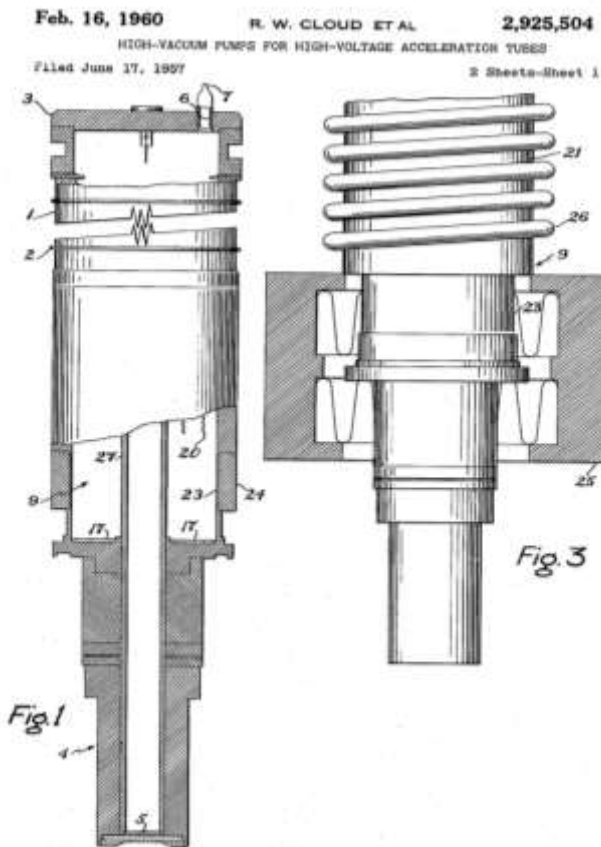

Figure 18-69: The first sketch of Trump and Cloud's patent application for a vacuum pump with serial number 666150 of 17 June 1957.

John George Trump was strict reviewer of Tesla's engineering legacy in January 1943, but he might have learned from Tesla's heritage the items he did

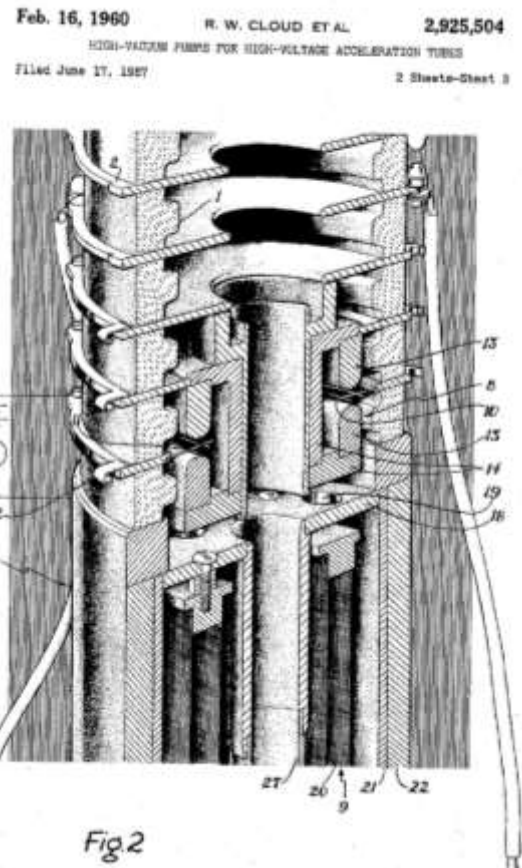

Figure 18-70: The second sketch of Trump and Cloud's patent application for a vacuum pump with serial number 666150 of 17 June 1957.

After three days of examinations John George Trump's results were discouraging with officially nothing military useful which he could find in

Tesla's papers of the last fifteen years. John George Trump noted some old instrument in Tesla's closet. Tesla's heritage was then passed to

Trump in the form of: "I'm not sorry because they steal my ideas, but I'm sorry because they have none of their own (Nije mi žao što mi krađu moje ideje, nego mi je žao što nemaju svojih)."



Figure 18-71: John Trump

Tesla's nephew, the top Serbian pro-communist politician Sava Kosanović (1894-1956) who happened to be Tito's minister for informatics in March 1945 and the Yugoslavian ambassador in Washington and Mexico in 1946-1949. Sava Kosanović transferred those papers to Beograd for the future museum of Nikola Tesla. Other Tesla's nephew then in USA, the son of Tesla's oldest sister Angelina, was the USA inventor Nikola Trbojevich (Trbojević, May 21, 1886 Petrovoselo in Lika-December 2, 1973 Los Angeles). Donald Trump happened to be John George Trump's nephew,²⁵⁷⁴ similarly as Lika-born Kosanović was Nikola Tesla's nephew. Both nephews of both electrical engineers developed into high profile politicians, although Kosanović's positions were more leftist than Trump ever imagined he could be. Tesla and Trumps were different: Tesla had new great ideas, and the money was not his primary goal, while Trumps had money and the new fashionable ideas were not their primary goal. John George Trump was certainly a smart engineer and without all FBI cards on the table it is not quite clear if Tesla slogan could be used for John George

²⁵⁷⁴ Rudolf Podgornik's suggestions on September 14, 2016; Amy Davidson, April 8, 2016, <http://www.newyorker.com/news/amy-davidson/donald-trumps-nuclear-uncle>.

19 Household Domestic Uses of Vacuum Technologies: Food Processing & Vacuum Cleaners

19.1 Vacuum Technology for Cooking and for the Preparations of Food

19.1.1 Introduction

Tesla recommended a healthy diet based on moderation. Of course, New Year's Eve or at least Easter holidays are coming in again when people like to have something good on the table. How can former and modern vacuum technologies help us?

The vacuum helps a modern man to preserve food, but recently we also learned how to cook in a vacuum. The storage of foods is becoming ever more indispensable for the everyday life of the contemporary people who want non-native delicacies. Although many storage procedures were invented already in Guericke and Boyle's times, the vacuum packing of foodstuffs is gaining momentum even with the offer of convenient home appliances. All those pursuits gained prosperity from the miniaturization of spaceship equipment, where lightweight flimsy vacuum preparations save quite a bit.

19.1.2 *Guericke's Grapes*

The vacuum pack with a dried up food was already on agenda of the inventor of the vacuum pump the Protestant Otto Guericke, after he served as an engineer in Swedish and then in the Saxon army during the Thirty years war.²⁵⁷⁵ Despite of his undeniable Protestant disapproval, he co-operated with his Catholic emperor Ferdinand III after the war. Between 1645 and 1648 the mayor Guericke represented the benefits of his city of Magdeburg at the Osnabrück conference, where the quarreling parties finally agreed to finish their Thirty-year

war. There he met with the Count Janez Vajkard Auersperg, who attended the conference in the imperial Embassy. They saw each other again during Guericke's visit to the Viennese court.²⁵⁷⁶ The clever Guericke has been eager to report on his vacuum experiments in those days.

Guericke attended the National Assembly in Regensburg as a politician full of scientific honesty. He showed experiments with air pressure and told the emperor and princes about new, barely discovered phenomena. The imaginative mayor was the first to weigh the air, which would still be considered today as a joke. He balanced his instrument with a vacuum container on one side and weights on the other. After he pumped out the air from the container, he discovered that some weight should be removed on the opposite side to regain the balance.²⁵⁷⁷

Guericke told the Emperor Ferdinand III, King Ferdinand IV, the king's tutor Auersperg and other princes about his experiments in an empty space, and by the way he mentioned that we could run out of air if we blow into a vacuumed vessel. He knew that many dangerous things could happen to us, since the external pressure does not only squeeze out all the air from the human or animal body into a vacuumed vessel, but also damages the body with the guts included; because of pressure, we can even die. The prince Auersperg still did not believe him. He was not prepared to abandon Aristotle's teachings from his students' bench, where the vacuum seemed to oppose the common sense. Even the recently deceased Descartes did not recognize any vacuum. Auersperg wanted to make sure of what was happening in a vacuum vessel.

At that time, the Auersperg prince had thirty-nine years and was almost more powerful than the aging emperor. The prince's doubts questioned all other Guericke experiments. It was a query of personal prestige: will Guericke convince the prince of the validity of his considerations? The engineer Guericke was not particularly at home in peripatetic logic, and he did not like discussions about the nature of the vacuum which suited his rival Boyle across the English Channel. As a

²⁵⁷⁵ Hellyer, Marcus. 1998. *The Last Of the Aristotelians: the Transformation Of Jesuit Physics in Germany 1690-1773*. PhD dissertation. San Diego: University of California, 1998, 279, 280.

²⁵⁷⁶ Guericke, Otto von. 1986. *Neue "Magdeburgische" Versuche uber den leeren Raum*. Leipzig: Akademische Verlagsgesellschaft M.B.H., 1986, 108.

²⁵⁷⁷ Guericke, 1986 *Neue*, 76.

trained engineer, Guericke observed an especially useful industrial tool in an empty space.

Guericke avoided a scholastic dispute with the prince Auersperg and left the decision to his carefully designed experiments.²⁵⁷⁸ To the Carniolan prince and other surprised magnates he showed how the vacuum "pulls" water up the tube, extinguished the candle and damped the ticking of the recently invented clock. To the lovers of grapes and its processed forms, which at that time were not lacking and are not missed even today, Guericke served a very welcoming news: "Finally, it should be mentioned here: when we place the grapes in such a glass container, we empty it and then store it in cold place for half a year, the grapes' appearance will not change, even though it will lose all the juice." He rushed to explain the storage performance in the empty space: "From here, it follows that the juice in the empty space is evaporated, while otherwise it would return backwards and remain in the interior due to the pressure of the ambient air."²⁵⁷⁹

The vacuum entered the Central European society and its cuisine in a particularly magnificent way, under the critical eye of the Carniolan Auersperg prince, who certainly did not refuse the well-coated table. In 1666, his brother, the Provincial Governor General Volf Engelbert,²⁵⁸⁰ ordered to hunt down 2256 quails, 120 forest partridges and 26 field partridges for guests in his Ljubljana palace. He arranged the largest feast when the Emperor Leopold I visited his palace in 1660. The prince Janez Vajkard once captured more than three thousand quails in three weeks of hunting with falcons. He hunted in the Kočevje forests around Lužine around numerous fruit trees. In 1774 he shot eight bears in one day. The last of those bears, however, made a lot of troubles after the bear wounded twelve locals who helped with the hunt. When the bear threw himself on the thirteenth, whose surname happened to be Bear (Medved), the prince finally shot the real bear with its small initials.²⁵⁸¹ At that time the surname bear was very common at Kočevje and Kostel, while the meat of

the bear or sheep has always been loved by the hungry local folks with different surnames.

One of the later editions of Scappi's cookbook was in the Auersperg Library of Ljubljana, which enabled Volf's planning his feasts. Bartolomeo Scappi (1500-1577) was the cooking master of Pope Pius V, where he certainly did not miss well-stocked tables. He was a match to Walther Hermann Ryff (Rivius, † 1548), who published a small German pharmacy with a description of home remedies, especially cooking in Strasbourg in 1540 and 1542; the work was bought by the convinced lovers of a well-stocked table among the Škofja Loka Capuchins, Hohenwart from Kolovec and other Carniolans. That book with its full-colored sketches of plants²⁵⁸² was frequently reprinted in Strasbourg during the whole century under the pseudonym Quintus Appollinaris; one of the last editions was on sale in Mayr's store in Ljubljana in 1678. Many local gourmets were the grateful customers. The Library of Upper Castle belonging to Diocese of Ljubljana kept the medicine of Paracelsus fan Leonard Fioravanti (1518-1588) bind to a manuscript full of chemical and cooking recipes, even in the Slovene language, with the use of "bello (white) wheat flour".²⁵⁸³ The learned and world-minded Cistercians in Stična want to sweeten themselves with the delicacies by the culinary and pharmacy recipes of Eleonora Maria Rosalia duchesse Crummau (1647-1704) married to the mighty genus of Liechtenstein. The hungry priests bought the first edition of her book supplemented with a cookbook. In 1710, the reprint followed in Vienna, where, of course, good foods were never missed despite the motto "When you go to Vienna, leave your belly out" because of the expensive Viennese pubs. Once upon a time that Stična book, later became NUK's copy. That copy of Mrs. Crummau's book on 516 pages with an alphabetical register has no marginalities of its hungry users. Its prescriptions follow the instructions for using salt and healings.²⁵⁸⁴ The baron Erberg purchased the same book. In any case, the good natured Carniolans always accepted many cooking novelties with open arms, if not already with fat bellies, which made them especially perceptible for the modern preparation

²⁵⁷⁸ Hellyer, 1998 *The Last*, 280–282.

²⁵⁷⁹ Guericke, 1986 *Neue*, 49–50.

²⁵⁸⁰ M. Žargi, Potres v Ljubljani, In: *Melikov zbornik* (2001), 749, 750, 754.

²⁵⁸¹ J.V. Valvasor, *Die Ehre*, Laybach-Nürnberg 1689, I/II: 224; Žargi, 2002, 294.

²⁵⁸² Ryff, 1575, 109^v, 139^f, 143^r

²⁵⁸³ Terpin, 1655, 14, 17^r; Fioravanti, 1651 *Sopra la chirurgia*.

²⁵⁸⁴ E. M. R. Crummau, *Freywillig=aufgesprungener Granat=Apfel*, Grätz 1697, 1, 37, 325, 485.

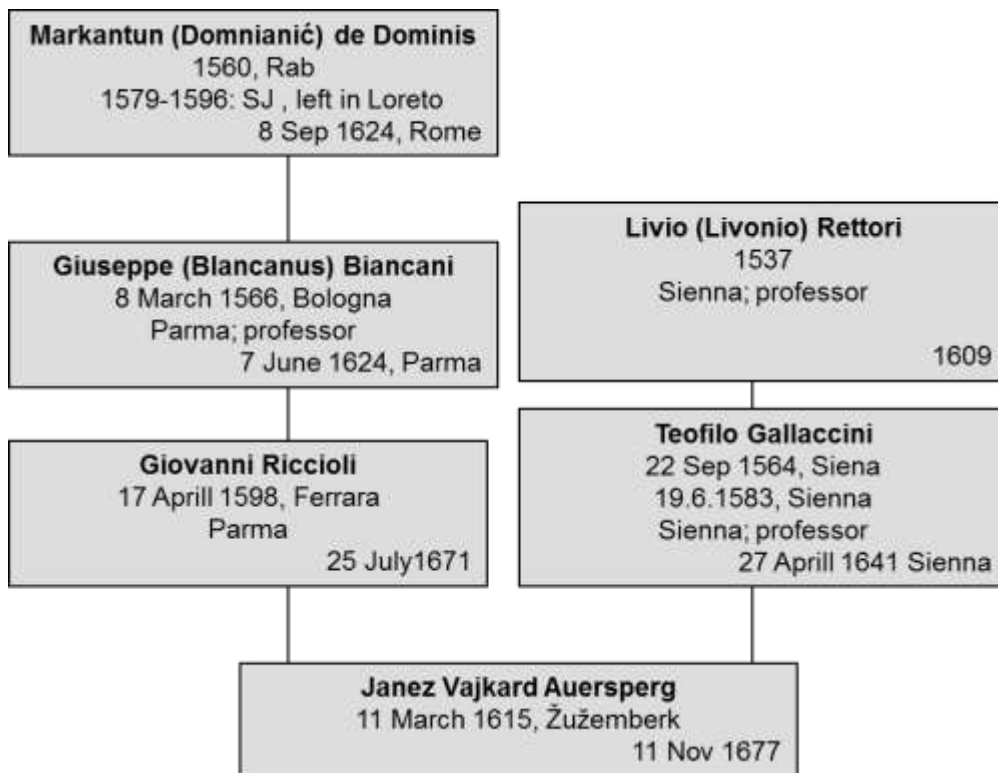

Figure 19-1: Academic ancestors of Janez Vajkard Auersperg (Turjaški) according to his studies in Bologna and Siena

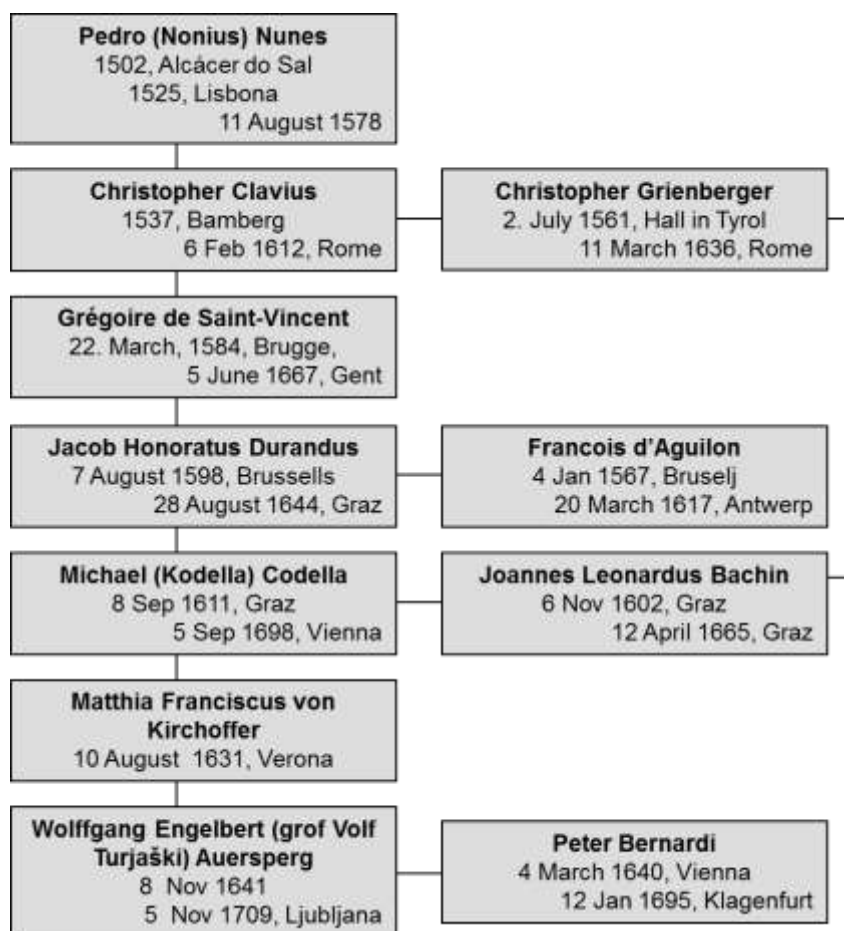

Figure 19-2: Academic ancestors of the nephew of the first Slovenian vacuum researcher Wolfgang Engelbert Auersperg (Count Turjaški)

of foods by vacuum techniques, that is, by using empty.

19.1.3 Boyle's Vacuum Pump and Wine

While Guericke and Auersperg prince designed their pioneering vacuum-supported culinary art on the continent, they were even surpassed by the wealthy Robert Boyle, whose books were conveniently used by Prince Auersperg's friend Janez Vajkard Valvasor. Boyle devoted his third vacuum booklet to early experiments with *Machina Boyliana*. After Boyle's relocation to Oxford, he published his first experiments together with Robert Hooke in 1660. In the replies to the complainants, he developed the famous Boyle Law.

Boyle referred to Mersenne's Parisian exploration of compressibility and to the measurements of Florentine academics. He invited the most important Brits to witness his vacuum experiments to add an additional weight, as they used to say in those times. He described the freezing of steam by lowering the temperature when pressing it under the weight of a mercury column. In his criticism of Thomas Hobbes, he cited his older experiments in a mercury barometer.²⁵⁸⁵ Boyle rejected Hobbes by Guericke and Torricelli's experiments. According to Boyle's introduction for the reader's preface and in the preface (1680), "Hydrostatic paradoxes" were the continuation of Boyle's "Tractatus de Aëre" (1672), which was sold by bookstore of Janez Mayr in Ljubljana, and after Boyle's death it was translated into English language. Boyle compared the pressure in the liquid with Torricelli's vacuum test over a tube full of mercury. In his introduction for the reader, Boyle scorned Hobbes' rejection of the vacuum, since Boyle also disliked him as a monarchist politician. Boyle devoted his final conclusive chapter to the storage of foods in a vacuum, which particularly impressed Valvasor.

In June 1670, Boyle stored a half liter of pint of good French wine in a vacuum. In July 1671, in front of a cheerful, lightly intoxicated friends gathered around his table, he noticed that the stored wine did not lose his purity and color. We use his novelty today, when we drink half of our bottle of wine, pump out the air above the leftovers

and re-seal it again, so that we can drink it unchanged whenever we feel thirsty again. Valvasor and his teenaged sons in Bogenšperk did not drink a lot of wine despite the worry of Valvasor's first wife; however, Boyle's idea of storing wine has deeply touched Valvasor's soul developed above the Sava riverbanks vineyards.

During Boyle's wine vacuum experiment, Valvasor was in France and Germany,²⁵⁸⁶ and in the meantime, he also sailed to England. Did he taste Boyle's wine? It might have been nearly as much popular as Papin's digester used for royal cooking for the merry Charles II several years later.

Valvasor bought six Boyle's prints, including the Genevan collection of Boyle's works (1680) in thirteen volumes containing twenty-five major books. Valvasor's enthusiasm for Boyle can be expected as three Boyle's works were offered by the new Ljubljana bookkeeper Mayr in 1678. Valvasor was fourteen years younger than Boyle. Valvasor was in Paris and in England²⁵⁸⁷ during Boyle's final resettlement from Oxford to London in April 1668; he was well acquainted with Boyle's vacuum experiments.

Valvasor bought Boyle "Hydrostatic paradoxes" (1670) with three nice groups images showing capillary in the vessel, the pressing liquids and the consequences of the difference in pressure. Boyle's experiments were repeated by Valvasor at Bogenšperk to check the operation of the alleged siphons under Lake Cerknica, which Valvasor's friend Halley then demonstrated before the London Royal Society in honor of Valvasor's election among new fellows in 1687. Valvasor, as the first Carniolan member of that famous society, witnesses the extremely high quality of Carniolan Baroque science and technology, as well as the rapid expansion of English achievements among Carniolans.

19.1.4 Thermos

Guericke's and Boyle's novelties remained for a long time only a curiosity, although the cheap vacuum pumps were soon massively produced in the Netherlands and England. There was no serious industrial use for them before the invention of the

²⁵⁸⁵ Boyle, 1680 *Tractatus*.

²⁵⁸⁶ Reisp, 1983, 82–84.

²⁵⁸⁷ Mayr, 1678 *Catalogus*, 51–52; Reisp, 1987, 7.

cathode-ray tube and especially Edison's bulbs. Soon after that, a competition for the liquefaction of "permanent" gases were on the agenda which ended just before the First World War. As often happens with similar seemingly narrow focused scholarly competitions, several allegedly by-products emerged. Among them, in the Royal Institution founded by Rumford, James Dewar (1842-1923) invented the thermos flask for short-term protection of deeply cooled gases. It soon became useful in households.

Many German users of vacuumed vessels did not even know Dewar's successes; on the other hand, the English glassworks were not skillful enough. Thus, prior to 1898, Dewar had ordered the production of his vacuum containers in Germany.²⁵⁸⁸ Much more penetrating used to be the Berliner glassworks Fa. R. Burger & Co of Albert Paul Aschenbrenner († 1912) and his juvenile friend Reinhold Burger (1866-1954), while in 1901 Burger patented the X-ray cathode ray tube in collaboration with Wilhelm Conrad Roentgen (1845-1923).

Shortly thereafter in 1903, Burger patented a device named several months later thermos with his Berlin company R. Burger & Co. in Germany. In 1906 Burger was granted his patent in France, as well as in the United Kingdom and the United States; after those successes, the thermoses soon became available first in German shops, then elsewhere.²⁵⁸⁹ Initially, he created a thermos for safe short-term storage of liquefied oxygen needed for low-temperature experiments designed by Carl von Linde (1842-1934), a Zurich student of the founder of modern thermodynamic theory Rudolf Clausius.

In 1904 new uses of thermoses were introduced by Burger's compatriot the glassblower Muller from Coburn when he used a silver-plated vacuum insulated thermos to provide quickly a warm milk for his child without any additional cooking. Robert E Perry took thermos to the North Pole in 1909, and Ernest Henry Shackelton had it on the South Pole, while the brothers Wright and count Zeppelin launched thermoses into the atmosphere. The idea of Dewar (1874) and Adolf Ferdinand Weinhold's (1841-1917) design from 1881 became part of the everyday household needs. The clever

Burger then sold his patents to Thermos-Aktiengesellschaft in Berlin in 1909, founded in 1904 as the ancestor of the later Thermos GmbH, where they began to produce serials of thermoses for the market immediately after the World War in 1920. Burger simultaneously sold his rights to New York's Thermos Bottle Company, the sister company of Thermos-Aktiengesellschaft; companies had similar branches in Canada and the United Kingdom. The unprepared Dewar did not patent his discovery; when he remembered that he wanted to earn something, he lost his lawsuit against Thermos L. L. C. (Thermos-Aktiengesellschaft). Dewar tried to sue them to get money for his invention, but he was too late; so, the witty Germans were too clever for him. God knows whether he did not remember his famous ancestor at the Royal Institution Michael Faraday, who never patented his inventions of artifacts to avoid similar conundrums. The deeply religious Faraday felt deeply that big money belonged to businessmen, and poor fame to smart lovers of sciences.

19.1.5 Packing

The thermos flask was often not convenient enough and especially not fit for any long-term food storage; it was clear that the vacuum can extract oxygen from the food and thus eliminate most of the harmful bacteria. Half a century before the writer of these lines was born there, the freshness of the coffee in a vacuum sealed bag was preserved in San Francisco²⁵⁹⁰ as a first-class addition to the preparation of coffee. Already in 1812 gourmet Rumford prohibited the spoiling of taste of coffee with fermentation. The first vacuum coffee siphon was patented by the Berlin-based company Loeff in 1830, as Jean Richard recognized with his French patent in 1838. In 1960s the coffee bags took over the market from much slower vacuum coffee makers with their siphons which are again becoming popular in the US nowadays. There was a fast-food era, but it is over today, and folks need to relax.

In 1936, for the first time, frozen foods were delivered in vacuum rubber bags for the soldiers of the famous line of Andreas Maginot (1877-1932) in eastern France, while the polyvinyl displaced

²⁵⁸⁸ Mayr, 1678 *Catalogus*, 51–52; Reisp, 1987, 7.

²⁵⁸⁹ Soulen, 1996, 35.

²⁵⁹⁰ <http://chrisgrande.com/2010/07/24/the-history-of-hills-brothers-coffee-and-the-vacuum-seal-mystery/>

other convenient packaging in the 1950s. The modern vacuum packaging was launched by Doctor engineer Karl Busch (* 1929 Lörrach) with the help of his Turkish wife Ayhan (* 1934). In 1963 they founded Dr.-Ing. K. Busch GmbH in Schopfheim in southwest Germany. Karl built a convenient household vacuum pump in the basement of their house; after his verification he sent the device to the market. Half a century later his company gives bread to three and a half thousand workers.

19.1.6 Lyophilisation (Freeze-drying)

The removal of oxygen is not the only opportunity for vacuum to extend the durability of foods; in a vacuum, we can accelerate sublimation of ice from frozen foods. When the Vacuum evaporation process is applied to food and the water is evaporated and removed, the food can be stored for long periods of time without spoiling in a process invented by Henri Nestlé in 1866 for his Nestlé Chocolate fame, although the Inca and Shakers were already using a vacuum pan earlier to inspire Gail Borden's New York Condensed Milk Company in Texas in 1853 and in 1864. In 1897, the Frenchman Jacques-Arsène d'Arsonval (1851-1940) boasted that he used the Dewar flask for biological research on 11 February 1888. In any case, he successfully participated in the liquefaction of various gases, and in 1906, together with his assistant Frédéric Bordas (1860-1936), he initiated the process of lyophilization in the Parisian Collaboration Biophysical Laboratory; a vacuum drying process was discovered by removing sublimated ice from frozen temperature-sensitive biological and inorganic substances. Of course, sublimation has been known in Europe for centuries, but for a long time they have not been using it for drying; they did this only in the Andes in the diluted air at altitudes well above most European mountains. Those native Americans froze overnight and daily sunbathed potatoes (Papa) to sublimate their moisture thousand years ago to get Chuño useful for many years. The conquistadors, the Spanish Jesuit José de Acosta (* 1540; † 1600) in 1590, or son of the Inca nobleman Garcilaso de la Vega (* 1539; † 1616) in 1609,²⁵⁹¹ of course, described the Native American achievements, which the Europeans could not use; therefore, they later reinvented already

sophisticated Latin American ideas, just like they redesigned amalgamation in mining. Not surprising: even though the immoral Europeans military defeated the Native Americans, the Europeans were so filled by greediness that they never learned anything. The Native Americans developed an unparalleled better skilled cultivation of soil which made most modern European foods a Native American heritage. Of course, it is a pity that aggressive conquerors have maimed local civilizations, looking for gold, which was indeed hidden in the superior knowledge of crops developed by the indigenous people. So, we just had to reinvent the technologies that have always been everyday fun of the American native Indians, just because of the abandonment and unbridled grappling of our ancestors in their path of the grabbing of lands of others.

The modern lyophilization is a slow drying process where three times more energy is consumed than in ordinary drying. In the first drying phase (primary drying) we remove frozen water by sublimation in vacuum, in the second (secondary drying) we achieve the same by desorption. Thus, we remove water without breaking down the basic structure and composition of our food. The lyophilized foods are stable for a long time at room temperature, and the addition of water restores them to the original condition before final ingestion.

In the food industry with lyophilization developed between the WW1 and especially supplemented during World War II; we produced the dried mushrooms, spices, beverages, macaroni, cheese, steaks, fruits, leafy vegetables, vegetables, meat, fish with other seafood, poultry, dairy products and other plant or animal raw nourishments. The lyophilization process concentrates fruit juices, produce milk powder, instant coffee and tea; dry soups, children's or dietary foods are also manufactured.

19.1.7 Cooking in a Vacuum

Today, the food storage is not the only culinary use of vacuum; cooking in a vacuum in a way opposes higher pressure cooking of Boyle's assistant Denis Papin, who enthusiastically cooked chicken to the impressed King Charles II soon after Papin's invention in 1669. It is not just a matter of contrast between low and high pressures, but also the

²⁵⁹¹ Vega (Inka), 2009, 335.

opposition between slow and fast cooking, where the slowness may have a future as quickly as possible due to modern controversy.

The theory and the first loose experiments of prolonged cooking in water below the boiling point succeeded in Benjamin Thompson Count Rumford's kitchen in Munich in 1799, although he still used air for his translation of heat, after he had thoughtfully doubted the temperature of the boiling water as the best for cooking of all thousands types of foods. He often corresponded with the Slovenian expert Jurij Vega. In his essays, Rumford published a popular paper about fireplaces and chimneys, which also interested his American colleague, namesake and political opponent, Benjamin Franklin; Rumford's ideas were also frequently reported in the Ljubljana weekly *Wöchentliches Kundschaftsblatt des Herzogthum Krain*.²⁵⁹²

Rumford was not only happy to describe the cuisine of his era, but also designed one of the first cooking experiments at low temperatures. As a Bavarian war minister, he tested a potato-drying machine by placing a leg of a lamb in the hope that it could be cooked at a temperature considerably below the boiling point of water in the Munich Public Kitchen of the House of Industry. If the water in Munich boils down at temperatures by 10.5 degrees Fahrenheit lower than in London, he was convinced that it would also be possible to cook in London at this lower temperature. Of course, Mont Everest with a water boiling at temperatures by 30°C lower than at the seaside was only climbed for the first time half of a century later, and Rumford did not know much about Tibetan-Nepal cooking habits in the elevated Himalayan regions. In addition, the difference between the London and Munich boiling water was greatly overestimated in Rumford's narrations, since the differences of the altitudes lowered the boiling only by 2°C, and the additional influence of moisture could not be so great. Regardless, for the clever Rumford the boiling in the kitchen seemed like a huge loss, as the cooking in the boiling water is just as efficient as the cooking just below the boiling point, of course, without a significant non-economic fuel consumption used for the unnecessary boiling. Angry, and hungry because

his experiment did not produce his expected dinner after three hours of cooking, he left a half-raw roast in his oven, where the surprised chefs found it well cooked in the next morning. The count of course honestly ate well in those years, when he slowly danced away from his widowhood into not very brilliant marriage with the widow of the famous French chemist Lavoisier. It is not certain that Rumford cooked for his new lady by that new slow system, but their domestic quarrels peaked with their kitchen utensils without cooking purposes flying in both directions with to amuse Parisian spectators. Maybe one of the reasons was that Rumford criticized the theory of caloric of the first husband of his wife, the beheaded Lavoisier? Rumford still liked Paris and remained there until his end, while the French chefs endorsed his cooking innovations almost a century and a half later.

The process of Rumford was developed in the industrial way of cooking in the vacuum packing of stored delicacies half a century ago. Why should the vacuum package be open at all, if you can drop it into the pot as an insulation – that was certainly the way how the inventor was thinking about those problems. It's funny fact that most of the cooking is done by females, but still, the leading cooks including Rumford and his heirs were and still are – males. In 1974, the reinvention of Rumford's idea was attributed to Georges Pralus (* 1940; † 2014) at the Troisgros restaurant owned by Pierre and Michel Troisgros in the French city of Roanne. The clever Georges told his boss that Rumford's low-temperature, vacuum-cooked lamb, duck or foie gras retain their original look, fat, and better composition. The new method of cooking sous-vide at temperatures below the Pralus' temperatures was soon developed by a little younger Bruno Goussault (* 26 January 1942) by testing various foods during his teaching of leading chefs after 1970. After he gained his fame in France, he became a scientist at the Cuisine Solutions food company in Alexandria in Virginia. He found suitable cooking times and temperatures in vacuum sealed bags filled with various foods which we still enjoy today. Modern addicts of sous-vide cooking use air-tight plastic containers and cook sometimes for three days, but usually just a few times longer than regular cooks. We cook the meat sealed within the vacuum pack at 55-60°C while we prepare our vegetables at temperatures 80-85 ° C.

²⁵⁹² *Kundschaftsblatt*, 2/40: p. 629–638; 2/41: p. 645–653; 2/42: p. 661–670; 2/16: 247–249 (20. 4. 1776); 2/17: 263–267 27. 4. 1776); 2/16: p. 251–252.

19.1.8 Futures of Cooking *Sous-vide*

The cooking *sous-vide* saves energy and preserves the original appearance of the food, which promises a prosperous future. Nothing inside the void called a vacuum thus interferes with the very core of cooking art. The void initially featured just as a food storage device, while the vacuum-insulated thermos has long been a traveling aid in everyday lives. The future of vacuum packaging looks promising, because it is a nature-adapted storage process without the introduction of additives, which even deserve the admiration of picky nature protectionist. The cost of production limits the widespread use of lyophilization,²⁵⁹³ but the lyophilized foods are much lighter and less spacious: therefore, very suitable for a traveler. Here we witness another in a series of improvements developed for the needs of astronauts in their spacecraft that penetrated in everyday use.

The loadings from the hollow to the empty have always been the vanity fairs, but barely the vacuum enabled them to materialize and to "become flesh". Empty food cannot be eaten, but you can use vacuum to please your stomach better... Good appetite!

19.2 Vacuum Cleaners

Mechanical solution to floor cleaning might began in England in 1599 or in China even earlier. Before vacuum cleaners, rugs were cleaned by hanging them over a wall or line and hitting them repeatedly with a carpet beater to pound out as much dirt as possible. On June 8, 1869, Chicago inventor Ives McGaffey patented a "sweeping machine." While this was the first patent for a device that cleaned rugs, it was not a motorized vacuum cleaner yet. McGaffey called his machine - a wood and canvas contraption - the Whirlwind. Today it is known as the first hand-pumped vacuum cleaner in the United States.

John Thurman invented a gasoline-powered vacuum cleaner in 1899 and some historians consider it the first motorized vacuum cleaner. Thurman's machine was patented on October 3,

1899 (patent #634,042). Soon after, he started a horse-drawn vacuum system with door to door service in St Louis. His vacuuming services were priced at \$4 per visit in 1903.

The British engineer Hubert Cecil Booth patented a motorized vacuum cleaner on August 30, 1901. Booth's machine took the form of a large, horse-drawn, petrol-driven unit, which was parked outside the building to be cleaned with long hoses being kept through the windows. Booth first demonstrated his vacuuming device in a restaurant that same year and showed how well it can suck dirt.

More inventors would later introduce variations of the same cleaning-by-suction type contraptions. For example, Corinne Dufour invented a device that sucked dust into a wet sponge and David Kenney designed a huge machine that was installed in a cellar and connected to a network of pipes leading to each room of a house. Of course, these early versions of vacuum cleaners were bulky, noisy, smelly, and commercially unsuccessful. The first vacuum-cleaning device to be portable and successful at the domestic market was built in 1905 by Walter Griffiths, a manufacturer in Birmingham in England.

In 1907, a janitor in a Canton Ohio department store James M. Spangler (1848 Pennsylvania-1915 Chicago) deduced that the carpet sweeper he was using was the source of his chronic coughing. So, Spangler mounted an old ceiling fan motor onto a carpet sweeper and cut a hole in the back of the sweeper to attach fan blades which would blow dirt out of the rear of the cleaner into an attached dirt pillow case bag. With pillow as a dust collector, Spangler invented a new portable electric vacuum cleaner. He then improved his basic model, the first to use both a cloth filter bag and cleaning attachments. He received a patent in 1908.

Spangler soon formed the Electric Suction Sweeper Company. One of his first buyers was his cousin, whose husband William Hoover became the founder and president of the Hoover Company, a vacuum cleaner manufacturer. James Spangler eventually sold his patent rights to William Hoover and continued to design for the company while Hoover financed additional improvements to Spangler's vacuum cleaner. The finished Hoover's design resembled a bagpipe attached to a cake box,

²⁵⁹³

<http://www.zepther.si/MainMenu/Products/HomeArt/Vacsy/Product-Range.aspx>

but it worked. The company produced the first commercial bag-on-a-stick upright vacuum cleaner. While initial sales were sluggish, they were given a kick by Hoover's innovative 10-day, free home trial. Eventually, there was a Hoover vacuum cleaner in nearly every home. By 1919, Hoover cleaners were widely manufactured completed with the "beater bar" to establish the famous slogan: "It beats as it sweeps as it cleans".

The Air-way Sanitizor Corporation, established in Toledo, Ohio in 1920, introduced a new product called the "filter fiber" disposable bag, the first disposable paper dust bag for vacuum cleaners, the filter bag. Air-Way also created the first 2-motor upright vacuum as well as the first "power nozzle" vacuum cleaner. Air-Way was the first to use a seal on the dirt bag and first to use a HEPA filter on a vacuum cleaner, according to the company's web site.

James Dyson (* 1947 Cromer Norfolk) invented the G-force Vacuum cleaner in 1983. It was the first bagless dual cyclone machine. After failing to sell his invention to manufacturers, Dyson created his own company and began marketing the Dual Cyclone bagless vacuum cleaner, which works on the principle of cyclonic separation. It quickly became the fastest-selling vacuum cleaner ever made in the UK. He was knighted in the 2007 and elected a Fellow of the Royal Society in 2015 as a proof of usefulness of his fellow English William Shakespeare's *Much Ado About Nothing*.

20 Ether Full of Plasma: Total Vacuum: When there is Nothing Left & Forth Aggregate State

20.1 Radiometer and Pursues for the Total Vacuums

Radiometer has been the most interesting physical device for several years, which has spurred a lively discussion. However, it later almost drowned in oblivion of childish toys, as it turned out that it was not measuring the radiation pressure at all, even if it could provide some clues. Despite of those explanations prepared a decade after Crookes' invention, the misleading term radiometer is still in use, just like the rising sun contradicts Copernicans.

20.2 Introduction: a Complete Vacuum

Many researchers have tried to achieve a perfect vacuum in which there would be no molecules. The effort was like cooling to absolute temperature zero at the end of the 19th and early 20th centuries. Both research plans ended in a similar funny way with incomplete success. In that case of temperatures we even established the "third", Nernst's Law of Thermodynamics of the unreachable absolute temperature zero, which became a kind of limit like Einstein's velocity of light, while the upper limits of temperature, density or time remained unclear and subject to occasional changes just like the businessmen's wealth which seemingly has no upper limit but could go bankrupt. Similarly, the oil and other resources of Earth were openly limited in 1960s.

However, the competition to achieve a complete or at least nearly total vacuum did not get as much international attention as the simultaneous competition between vacuum-related researchers for condensing so-called "permanent" gases. It did not have a predetermined goal, as it has already been shown in the early days of research that billions of molecules are flying well even inside the best of the vacuums. Although Galileo himself

did not experiment inside vacuums, the thought experiment with falling in perfect vacuum was one of the foundations of his description of accelerated motion.

The total vacuum was later the center of the Crookes' research program. Despite Crookes' failure, the idea of the extreme limits of the vacuum was never completely abandoned. Thus, in the era of stagnation in bettering vacuum between 1920 and 1950, many researchers thought that with their 10^{-8} mbar they had reached an extreme vacuum which the hot-cathode ionizer can still measure so that progress will be no longer possible.²⁵⁹⁴ Or, at last, we will be unable to prove better vacuum with the measurements currently available even if the interstellar space might have approximately 1^{-15} Pa (1 fPa).

The radiometer is often seen in shops, especially in goldsmiths. It is a "light mill" illuminated in a low-pressure container. It is driven by a temperature difference and associated vacuum on the vanes. However, in the mid-1870s, most researchers thought that the mill flaps were rotating under the pressure of light rays. That's why Crookes gave a name to the radiometer, which is still used today, although it does not indeed measure "radiations". The interesting history of the device is intertwined with the exploration of the vacuum.

Crookes' radiometer was already familiar before him. Mairan described his light mill as "a horizontal wheel of iron with a diameter of about 7.5 cm on an iron axis with an oblique vane on each side. The wheel and the axe put together are lighter than 1.95 g."

Under the rays of sunlight in the lens's focal point, the wheel did not rotate properly. Mairan described the air flows near the device. He intended to test it in a vacuum, but he postponed the plan due to difficult implementation.

In 1751, the Cartesian French Oratorian priest Bertier showed Parisian academics Réaumur, Nollet and others an experiment in which the needle was sealed in a vessel by the flame. Jean-Jacques Rousseau's friend the physician Bertier was elected FRS in 1769. For a similar experiment, the geologist Michell used a torsion scale,²⁵⁹⁵ with

²⁵⁹⁴ Redhead, 1999, 144.

²⁵⁹⁵ Rosenberger, 1890, 681, 679.

which Cavendish later measured the gravitational constant.

In the beginning of 1766, Franklin advised his English friend Priestley to handle similar experiments with the windmills. Franklin felt that the windmill, without any obvious cause, could chose this or the opposite direction of rotation. Priestley experimented for almost a year in various circumstances. He first used halves of the playing cards for his vanes; thirteen of them were planted in a cork and fixed with a needle on a glass stand connected to a point conductor few inches away from the recently invented Leyden jar. At discharges, the fan flap always turned in the same direction, often so quickly that it was not possible to distinguish the vanes. Later, he replaced the cards with lighter strong white paper. He made dozens of windmills with diameters of 3 inches and lengths of 2.5 inches. Following Canton's advices Priestley wetted the paper vanes to increase their electrical conductivity. In other experiments, the crevices with metallic glitter or thin pieces of brass are of the same shape. He also used an automatic rotating spindle for the wind turbine. He replaced his paper by lighter gold sheets, even in windscreens with horizontal axes, which were still spinning at the distance of 30 cm from the source of electricity. He placed a candle near the wind turbine, which flowed up the air. Therefore, he thought that the flap was driven by the gust of wind, although, for example, Canton considered it to be an electric deflection.

John Smeaton from Leeds was a civil engineer and first user of a "hydraulic lime" for underwater construction. He paved the way for the discovery of modern cement in 1756. He made a two-way air pump. Priestley used the device during his work at future prime minister William Petty 2nd earl of Shelburne's (1737 Dublin-1805) great lab in Calne in 1774-1780. The Italian Tiberius Cavallo used Smeaton's pumps for his measurement of specific weight of gases.

In Wilson's discussion, Priestley read that the fan in the vacuum does not rotate. He repeated Wilson's experiment with the same result. When he dropped the air into the vacuum container, the windmills revolved.

Differently from Crookes one hundred years later, Priestley did not bleed the windshield vanes and did not put it in a vacuum to often, although he liked experimenting in a void. In the following years, he used primarily a pump for pressures down to 1 mbar.²⁵⁹⁶

William Crookes' father was a rich tailor. Therefore, after studying and serving at the Royal College of Chemistry in 1854, William could devote himself entirely to research. In 1863 he became FRS. In 1885, he moved to Oxford, where he persistently investigated the most pressing issues of physics until his last days. After 1900, he also started researching radioactivity. In 1897, the queen Victoria honored him with the title of the knight. Crookes was a president of the London Ghost club in 1907-1912 before he served as president of the RS between 1913 and 1915. The experimental sciences and paranormal research worked in close connection among the Brits before WW1.



William Crookes (* 1832; † 1919)

In his report in 1792, the Bentley parish priest Abraham Bennett failed to turn the needle under influence of the flame. His negative result has been used by various researchers for a long time against

²⁵⁹⁶ Priestley, History 1966, 2: 187–190; Priestley, *Autobiography* 1966, 21, 29, 31–33, 39, 42, 52, 109.

corpuscular theory of light including Thomas Young in London and Stewart at the Kew Observatory in 1866.²⁵⁹⁷

The author of the transversal wave theory of light, Fresnel, built a two-tank metallic mill in an emptied container with a pressure of 1 or 2 mbar in the Parisian Polytechnic in 1825. The mill spun when it was illuminated by sunlight. Like Crookes half a century later, Fresnel also considered that the phenomenon was caused by the convection of warmed air or evaporation from surfaces, as the phenomenon hardly changed at twenty times greater pressures.²⁵⁹⁸ In the same year he placed two panels suspended on a silk thread in a vacuum container. The plates mutually repelled each other when lighted by sunlight reflected by the collecting lens. A similar phenomenon was observed by Alexandre Claude Martin Lebaillif in Paris in 1829 and later by Jacques Frédéric Saigey (1797 Montbéliard-1871 Paris).²⁵⁹⁹ However, Fresnel soon died, so his discovery was forgotten until Crookes mentioned his research.

Pouillet and Desperetz, a professor of physics at Sorbonne in 1849, explained such experiments with heat and warmed air. Desperetz also examined the thermal effects on the motions of the needle of galvanometer.²⁶⁰⁰ In the same year he compiled a furnace heated by the combined action of the Sun, electricity and the torch.

20.2.1 Crookes's Discovery

Crookes liked Kirchhoff and Bunsen's spectroscope, which enabled their discovery of cesium and ruthenium in Heidelberg in 1860 and 1861. The new elements were named by their characteristic blue-gray or dark-red spectrum. Crookes followed their example, discovered thallium and named it after the green leaves in 1861. He was, of course, only a tailor's son, but he was therefore not inclined to lag somewhere behind the more appealing Latin titles of German university professors. Crookes believed the

²⁵⁹⁷ Bennet, 1792, 81; Young, Phil. Trans. 1802, 92: 46; Stewart, 1866, 161, 352.

²⁵⁹⁸ Fresnel. 1825. *Annales de Chimie et de Physique*. 29: 57–62, 107–108; Woodruff, 1966, 192

²⁵⁹⁹ Fresnel. 1825, *Bull. de la Soc. Philomath.*, 84;

Rosenberger, 1890, 679.

²⁶⁰⁰ Rosenberger, 1890, 213, 679–680.

assumptions of the London practical physician W. Prout that the atomic masses of all the elements are always the multiples of the mass of the hydrogen atom, published anonymously in London in 1815. Therefore, Crookes tried to measure accurately the atomic mass of the thallium. However, Crookes measured a value of 203,642, slightly lower than the modern value 204,383, but, clearly contrary to Prout's assumptions.

Crookes' assistant was an extremely skillful glassblower the young Charles Henry Gimingham (1853-1890). In Crookes's research, he played an important decisive role, like that of Geissler at Plücker's lab in Bonn, while Gimingham was also a kind of member of Crookes' household. After his marriage, Gimingham needed more money and left Crookes to join Swan's United company, later joint Swan & Edison company in Newcastle where he worked together with his brother E.A Gimingham and Maxwell's student J. A. Fleming.

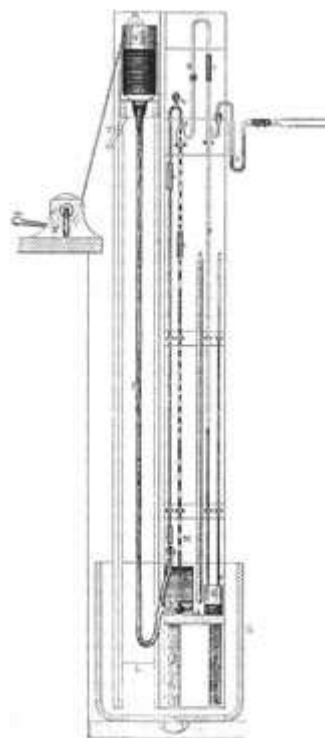

Figure 20-1: Crookes and Gimingham's pumping system with a single Sprengel pump during their initial exploration of a radiometric phenomenon.²⁶⁰¹

To determine the atomic weight as accurately as possible, Crookes and Gimingham measured in a vacuum. They found that the heating of the device

²⁶⁰¹ Redhead, 1999, 143.

reduced the measured mass. More detailed research has shown that the mass decreases if the source of heat is below it because the measured object moves upwards.²⁶⁰² Therefore, in the 1870s, they experimentally exhausted the container to a "perfect" vacuum, in which the flows of the remaining molecules would not interfere with weighing. They added Andrews' chemical pumping methods to Sprengel's pump.²⁶⁰³ They developed pumping system with a single Sprengel's pump in 1872. By the following summer, they already produced a vacuum through which the Ruhmkorff inductor could not be discharged (Figure 20-1).²⁶⁰⁴

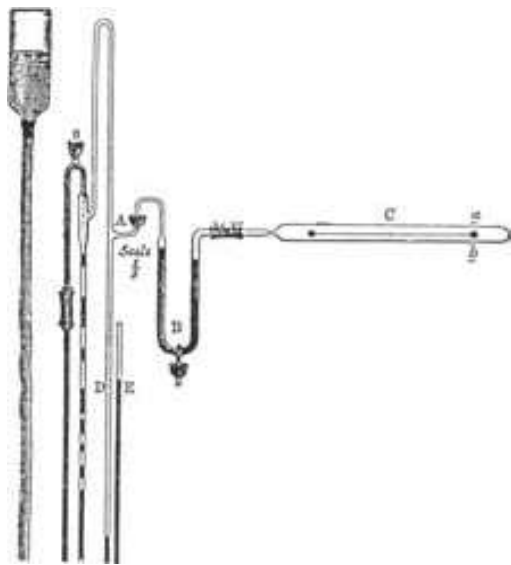

Figure 20-2: Crookes's first device for measuring radiometric force designed in 1874²⁶⁰⁵

To investigate the force that disturbed the measurement of atomic weight in a vacuum, they compiled a device for measuring "repulsion by radiation". That became the title of their series of six papers which they communicated to the RS between the years 1874 and 1878. First, they used a balanced rod in a vacuum vessel, which was heated on one side by the flow of hot water. The meter was later improved so that they measured the simple movement of the lever with the elderberry spheres at the ends in the smaller vacuum vessel. When the elderberry balls were heated from the bottom, they rose. If the container was emptied even more, the effect decreased and at 9 mbar, when "the last trail of the air was removed from

the container ..., the elderberry balls remained stationary." When the pressure was lowered, the elderberry sphere rose again if they were warmed from below.

Crookes thought that the relationship between heat and gravity was finally determined: "Although the force that I talk about is certainly not the usual weight, the attraction comes from chemical action. It connects the largest and most mysterious natural force, remote operation, with better known substances. The energy of the Solar radiation can finally turn out to be "constantly working according to certain laws" that Newton had for the cause of gravity" (Figure 29-2).²⁶⁰⁶



Figure 20-3: Photograph of James Clerk Maxwell (* 1831; † 1879)

Crookes hoped that his discovery could solve the problem of tails of comets. The Comet C/1874 H1 of Jérôme Eugène Coggia was the one of those that aroused admiration in Europe in those summer weeks of 1874. Astronomers have been searching for the repulsive force of the Sun for a long time, perhaps even the luminous pressure that forces the gaseous part of the comet away from the core. The phenomenal comet has certainly prepared scientific circles for the forthcoming debates on the radiometer. Due to frequent conversations about the comet at James Clerk Maxwell's house in

²⁶⁰² Brush, Everitt, 1969, 106.

²⁶⁰³ Andrews, 1889, 223–224.

²⁶⁰⁴ DeKosky, 1984, 84, 88.

²⁶⁰⁵ Woodruff, 1966, 189.

²⁶⁰⁶ Woodruff, 1966, 190, 191.

Cambridge, his home-grown terrier Toby ran in a circle at each mention of the tail of a comet and chased his own tail to amuse the gathered scientists.

In 1874, Crookes introduced his mill to the RS, where it was then put on display. All visitors felt that the mechanical energy of the light was directly involved. Maxwell initially joined the general opinion (Figure 20-3).

Englishman **Osbourne Reynolds** of Belfast studied in Cambridge. Between 1868 and 1905 he was a professor of engineering at the University of Manchester. He continued his radiometric research with fluid dynamics. In 1883, he announced that the laminar flows turn into a turbulent flow, when the number that we now call by his name grows over the critical value. He also developed a theory of lubricants, measured the mechanical equivalent of heat and designed many turbines.



Osborne Reynolds (* 1842; † 1912)

This phenomenon interested Maxwell because of the kinetic theory he published in 1867, as well as due his electromagnetic theory with which he similarly predicted at much lower pressures:
 ». . . From here, the average force by which sunlight is pressing against the square meter area equal to 0.00000041 kilogrammeters.²⁶⁰⁷ This pressure is created only on the illuminated side of

²⁶⁰⁷ $4.1 \cdot 10^{-7}$ Pa.

the body, so the body will be pushed in the direction of motion of the solar rays.²⁶⁰⁸ The focused electrical light would probably push even more, and it is not impossible that the rays of such light that would fall on a metallic plate in a vacuum would produce a noticeable mechanical effect."

Maxwell accepted to values Crookes paper for the publication in Phil. Trans. At that time, he agreed that Crookes measures the pressure of radiation, the collisions of waves onto a solid surface. Crookes then improved the vacuum in his container with the use of charcoal as getter according to Dewar's advice.

20.2.2 Crookes's Antagonists

Reynolds among the first contradicted Crookes' claims with the assumption that Crookes measured the reflectance phenomenon due to the temperature gradient. A year earlier, Reynolds published a study of condensation of a mixture of steam and air on cold bases in a steam engine. Therefore, he claimed that the radiometric phenomenon also depends on the evaporation of the air molecules on the vanes of mill. Similarly, he wrote that the tail of comets is due to electric force or because of a "negative shadow". He wished to explain Crookes' (1874) experimental results with the repulsion of the elderberry balls from the flame of the candle with the higher temperature of the ball on the heated side. Faster molecules on the hot side are more likely to push the ball and therefore to move it. However, in 1875 Dewar and Tait proved that faster molecules collided quicker with their neighbors. Thus, the pressure should be compensated everywhere despite of temperature differences.²⁶⁰⁹ Although the early Reynolds' theory of the radiometric phenomenon was later discarded, it nevertheless directed subsequent explanations to the problem of gas-to-surface interaction.

In the winter of 1873/74, that is, before Crookes's first publication, Schuster returned from observing the solar eclipse in the expedition of Norman Lockyer in Thailand. He immediately examined Crookes' mill, exhibited at the RS. Schuster was an unpaid assistant at the University of Manchester.

²⁶⁰⁸ Maxwell, 1873, 793; Brush, Everitt, 1969, 109;

Rosenberger, 1890, 683.

²⁶⁰⁹ Dewar, Tait, 1875, 217–218; Woodruff, 1966, 193.

There he described to Reynolds and others his decisive experiment measuring whether the radiometer vessel was rotating in the opposite direction of rotation of the vane of the mill. Schuster apparently reversed the experimental focus on whole vessel instead of its vanes, just like Salcher or Torricelli did in their times. Such a rotation of radiometer would mean that the displacement of the vanes was not brought into the container from the outside. The rotation of the vanes was in this case dependent on an internal mechanism, presumably related to the remaining gas in the exhausted vessel. But Schuster did not want to carry out the experiment alone, "because it would appear that he is intervening in the work of others". Schuster, like Crookes, was involved in the spectral analysis of light at the beginning of his research pursuits. Unfortunately, Schuster and Crookes advocated the opposite interpretation of the radiometric phenomenon. In 1875, Schuster returned from Germany to Reynolds's labs at the University of Manchester, where they hung the radiometer housing on two silk threads. The scientific spectacle was awaiting the outcome of their experiment. J. Thomson recalled half a century later "relief when he heard that the device was rotating in the opposite direction from the flap."²⁶¹⁰ In February 1876, Schuster affirmed Reynolds's assumptions that the remaining gas directly rotates a radiometer.

Gimingham carried out a similar experiment. He put the radiometer in the water, prevented the movement of the flap with the external magnet, and noticed the rotation of the casing in the direction opposite to the course of spinning of free flaps without magnets involved.²⁶¹¹ In April 1875, Crookes measured that the light press more the black than a white or silvered surface of the radiometer flap. The results like those were repeated by other researchers. Because the light rays were reflected from the silvered side, the pressure on them should be twice as high. Therefore, in June 1875 Maxwell also gave up the idea of a radiometer measuring the direct impact of incident rays on the substance. He found that the blackened surface is not pushed more by the source of light because it radiated more, but because it is

hotter.²⁶¹² Maxwell referred to the experiments of Kundt and Warburg (1875). With slower cooling of the thermometer in vacuum, they confirmed that the internal friction did not depend on the pressure of ideal gas, which Maxwell described for the first time in a letter to Stokes on May 30, 1859.²⁶¹³



Figure 20-4: Crookes' radiometer²⁶¹⁴

Clausius's kinetic theory with the mean free path of molecules did not promise a complete description of the radiometric phenomenon. In the mill, the average free pathway of the molecule may be greater than the distance between the solid surfaces of the flaps of the mill at which the molecule collides. Therefore, there is no equilibrium due to collisions between molecules; irregularly heated flaps can cause large temperature differences in the surrounding gas. However, at that time no one was able to calculate the resultant forces due to the temperature gradient without doubtful additional assumptions.

Crookes compiled a "light mill" in the later most famous form with four vanes in a glass container and named it a "radiometer" (Figures 20-4 and 20-5). The weight of horizontally rotatable, on each opposite side blackened vane should not exceed

²⁶¹⁰ Thomson, 1936, 373–374; Woodruff, 1966, 194; Brush, Everitt, 1969, 111; Feffer, 1989, 35–36.

²⁶¹¹ Crookes' lab diary, 28. 3. 1876 (DeKosky, 1984, 94).

²⁶¹² Maxwell's letter to Stokes, 10. 2. 1876 (DeKosky, 1984, 94).

²⁶¹³ Kundt, Warburg, 1875, 156; Brush, Everitt, 1969, 113.

²⁶¹⁴ Ganot, 1886, 400.

0.13 g. The blackened side moved towards the light source at ordinary pressure. When the air was pumped out of the container, the rotational speed of the flap was lowered, and the flap finally stopped. After further pressure reduction, the mill began to turn again, but this time in the opposite direction. The initial presumption was that the radiometer's vanes are spinning faster with the best possible vacuum around them. Crookes had to abandon those ideas due to experimental results in mid-June 1876. It was calculated that at each cm^2 of the flap the pressure was equivalent to the mass of 0,01 mg.²⁶¹⁵ In modern units, this pressure is 10^{-4} Pa, almost 250 times more than predicted by Maxwell in 1873.

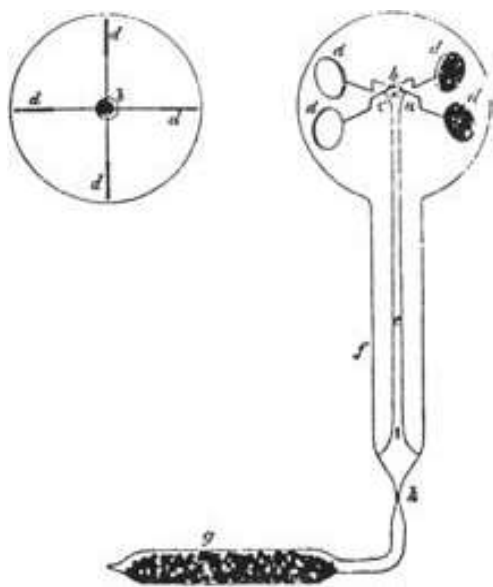

Figure 20-5: Crookes' sketch of radiometer at his discussion *On Repulsion Resulting from Radiation* published in 1876²⁶¹⁶

In mid-April 1876, Gimmingham used three pipes to drop his mercury instead of one. He reached 0.004 mbar measured with McLeod manometer, which he began to use in the middle of summer 1876 (Figure 20-6). All the researchers agreed that the exact measurement of pressure inside the radiometer would determine what spins the vanes in it. That is why Crookes and Gimmingham complemented their measurements of pressure by observing the electrical phenomena and the speed of rotation of the radiometer.²⁶¹⁷

²⁶¹⁵ Crookes. 1876. *Phil. Trans.* 166: 338–345; Woodruff, 1966,193; Ganot, 1886, paragraphs 445, 399, 401; DeKosky, 1984, 92.

²⁶¹⁶ *Phil. Trans.* 166 (1876) 339.

²⁶¹⁷ Andrade, 1984, 82; DeKosky, 1984, 85, 98, 99; Redhead, 1999, 139.

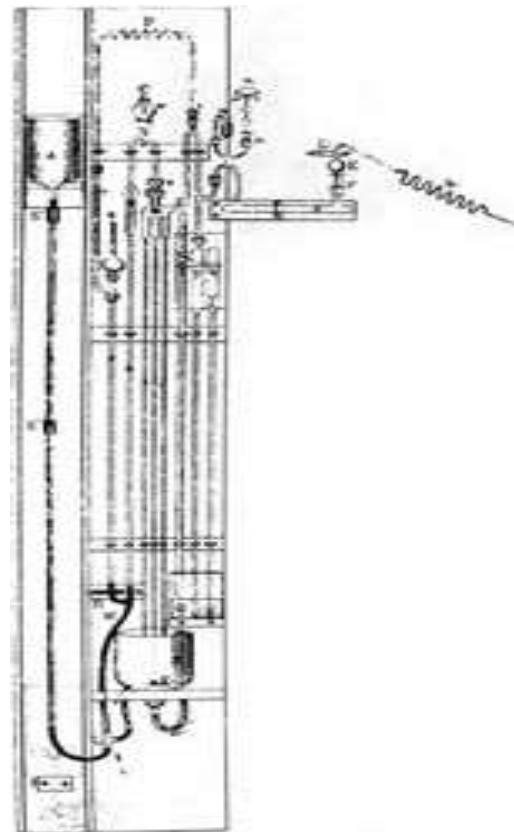

Figure 20-6: Gimmingham's improvement of the Sprengel's pump, as used with Crookes at least from mid-April 1876.²⁶¹⁸

Meanwhile, interest in the radiometric phenomenon has expanded into the highest levels of English society. On May 15, 1876, Maxwell wrote to his maternal uncle Robert Cay (1807-1888) how he describes Guericke's Magdeburg experiments and Crookes vacuum research to Queen Victoria herself. In doing so he wistfully remarked that "... her Majesty however let us off very easily and did not make much ado about nothing, as she had much heavy work cut out for her all the rest of the day."²⁶¹⁹

In the autumn of 1876, Crookes came to the idea of the fourth aggregate state of the substance during the study of the difference between the illumination of convex and concave flaps in the radiometer.²⁶²⁰ Two years later, he published experiments with a radiometer that had vanes made of golden leaves blackened on a one side. When the illuminated mill turned in the opposite direction, otherwise that usually, with the side facing forward, he has noticed that one leaf was wrinkled. Crookes took advantage of that random

²⁶¹⁸ DeKosky, 1984, 96.

²⁶¹⁹ Brush, Everitt, 1969, 112.

²⁶²⁰ DeKosky, 1984, 99 .

discovery by covering the top half of the radiometer and illuminating only the lower half, where the flaps were rotated with the blackened side towards the source of illumination (Figure 20-7).

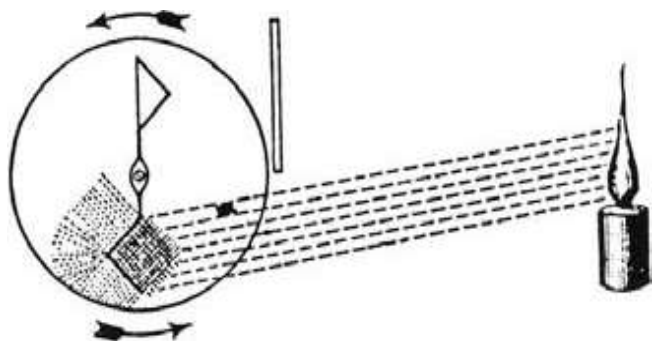

Figure 20-7: Crookes radiometer with field lines of molecular pressure.²⁶²¹

20.3 Maxwell and Reynolds' Theory of Radiometer

Immediately after the exchange of views on the radiometer begun, it turned out that the pressure of the light does not, however, cause the mill to rotate. Maxwell knew that the radiometer was a serious physical problem, although it was possible to do simple experiments with it. That is why he was careful in his judgments, especially in his reviews of the Crookes, Reynolds and Schuster's papers for the RS. At the beginning of 1877, Maxwell persuaded Schuster to move from Manchester to his Cavendish Laboratories. In May 1877 Schuster brought four radiometers to the Cavendish laboratory. He surely inspired Maxwell, who at the same time provided the definition and explanation of the radiometric phenomenon. Maxwell finished the work the next spring, but he added the notes to the paper already gravely ill a year later. He devoted most of his space to calculating the force due to temperature differences in the interior of the gas, where the pressure is proportional to the second derivative of the temperature with respect to volume. He rejected early theories of FitzGerald and Stoney who believed that a constant temperature gradient should suffice for the difference in pressure. According to Maxwell, a small mill in gas as a source of heat is enough to change the temperature gradient and thus to the pressure that spins the mill.

²⁶²¹ Woodruff, 1996, 196.

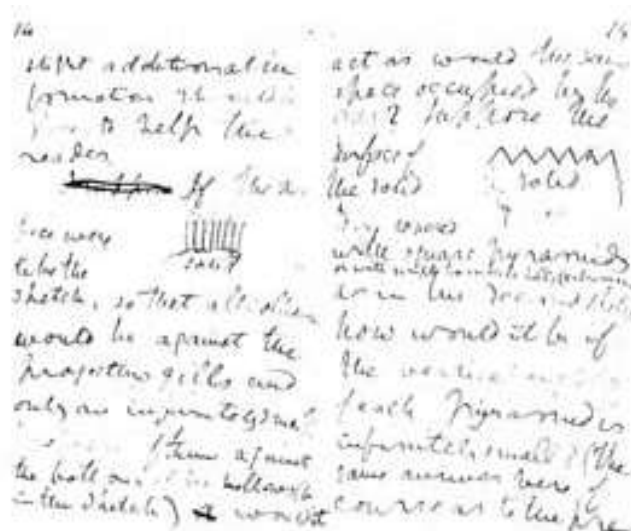

Figure 20-8: Manuscript W. Thomson (later Lord Kelvin) estimation Maxwell's discussion on 15. 6. 1878.²⁶²²

W. Thomson reviewed Maxwell's paper prior to publication by RS on June 15, 1878. Maxwell further explained the problem in his letter to W. Thomson three months earlier. Maxwell knew, of course, that his friend W. Thomson was a reviewer of his discussion, even though the RS Secretary Stokes sent him just a typed transcript of the review (Figure 20-8).

Crookes' sixth and final paper in his discussion group "On repulsion by radiation" was sent to Maxwell for review only two weeks earlier than Thomson's report on Maxwell's own paper was received. Maxwell supported the publication of Crookes' work on October 23, 1878. Three months later Maxwell received Reynolds's general theory of gas flow in the radiometer with the discovery of "thermal transpiration". Thus, Reynolds named the gas flow through a perforated plate due to the temperature difference between the sides of the panel, which was one of the main discoveries of the quarrels about the radiometer. He found that the radiometric phenomenon depends on the ratio between the size of the flap of the mill and the average free path of the molecule in the gas. The phenomenon disappears at very large flaps or in cases of very small mean free paths. However, to validate the theory, one should diminish the openings so much that the measurement would no longer be possible. Therefore, Reynolds preferred to fix the radiometer flaps in Gimmingham's manner, so that the air would move through the

²⁶²² Brush, Everitt, 1969, 116.

radiometer in the opposite direction. The experiment with small flaps would thus be replaced by an experiment with small spaces designed for the flow of gas; that is, with perforated vanes.

In his assessment of Reynolds' paper, Maxwell supported his experiments, but not his theories. For this reason, the frightened Reynolds slightly corrected his claims, as it was not good to quarrel with the famous guy like Maxwell. In May 1879, Maxwell supplemented his own paper by considering the surface phenomena in gas, about which he was reading in Reynolds's yet unpublished paper. He rated his method as better. Reynolds did not accept Maxwell's ideas, but criticized them in a letter to RS Secretary Stokes. Several hours after Maxwell's death on November 5, 1879, Stokes telegraphed Reynolds to modify his criticism or to allow his comment. The latter possibility prevailed. Thus, Stokes read before RS Reynolds's criticism and Stokes's opinion, in which he said, among other things, that the late Maxwell partly conceived his theory on the advice of W. Thomson. Reynolds, of course, deeply resented the leading members of the RS with the criticism of Maxwell who just passed away. Thomson made a special effort, and after a detailed study of literature, he even questioned Reynolds's priority in the discovery of "thermal transpiration," since the phenomenon was already discussed before him by the German W. Feddersen, assumedly Berend Wilhelm Feddersen (1832-1918 Leipzig), according to the predictions of Carl Gottfried Neumann (1832-1925) from the University of Leipzig, son of the famous crystallographer FE Neumann. Everybody was angry because of Reynolds's insulting the demigod Maxwell, who just passed away without any faults deserving mention.

20.4 From Radiometer to Cathode Ray Tube Electronics - "Electric" Radiometer

Just as Crookes' chemical problem led to the study of a vacuum, which was initially merely a research tool, his ten years-younger friend Dewar went from a chemical problem to the design of thermos and then to the liquefaction of "permanent" gases. With Maxwell's death, Crookes lost the main supporter

of his theory of radiometer. In the mid-1880s, Crookes finally accepted the impossibility of a total vacuum and, after a long resistance, confirmed the remaining gas as the cause of the radiometer's motion. The latest Crookes' discussion of "radiation reflections" was, according to Maxwell's reviewing, read before the RS on 21 November 1878. The first discussion on "the light of the molecular pressure lines and the rails of molecules" was read only two weeks later. Thus, Crookes skipped from the radiometer to the cathode-ray tube, from the radiometric forces to the cathode rays, from a perfect vacuum to the phenomena of the "fourth aggregate state of matter in incomplete vacuum".²⁶²³ The "light" mill was placed in a cathode-ray tube and became an "electric radiometer". It seemed to him that the dark area around the cathode is similar if not the same as the invisible layer of gas flow in the radiometer, where the pressure of the molecules is increased. As a devoted researcher of now obsolete radiometer, Crookes planted his radiometric visions whenever he could, as the humans usually do:

"For a long time, I am under the impression of the idea that the dark layer around (electrode of cathode ray tube) is somehow connected to the layer (of overpressure) of the molecules that causes motion in the radiometer."²⁶²⁴

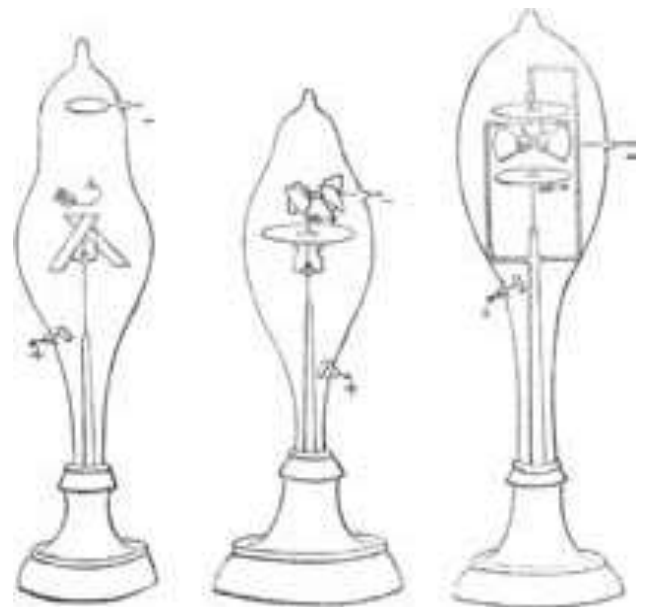

Figure 20-9: Puluji's "electric" radiometers with phosphorescent flaps²⁶²⁵

²⁶²³ DeKosky, 1984, 84, 95, 97.

²⁶²⁴ Woodruff, 1966, 196-197.

²⁶²⁵ Puluji, 1889, 292.

First, Crookes tried to measure the "layer of molecules' pressure" with the small mills placed around the main mill. However, small mills soon became electrified and thus hampered the measurement. He therefore compiled an "electric radiometer" containing a cathode in a form of a mill with aluminium flaps blackened on one side. The dark area of the discharge stretched longer on the blackened sides of the flap than on the side which was not blackened. When the dark layer reached the wall of the vessel, the mill began to rotate with the blackened side facing forward, like in a regular radiometer. Crookes assumed that the molecules were moving away from the negative electrode therefore rotate his mill. Hittorf considered in Münster that the rotation caused an annealing of the heated glass of the vessel. Puluj from the Viennese Physics Institute, who began investigating the radiometric phenomenon at Kundt's lab in Strasbourg in 1875, rejected them both, Crookes as well as Hittorf. If Hittorf's assumption was to apply, we could rotate the radiometer by heating its glass housing touched with our hand. Puluj attributed the rotation to the three opposing causes: radiation from the electrode, thermal movement due to the heating of aluminium vanes and the thermal radiation of the glass wall of the cathode ray tube. The individual causes prevail at different pressures and therefore, dilution of air changes direction of rotation of the flap. At pressures of 0.03 mbar, radiation was described according to Stefan's law. In subsequent experiments, Puluj coated his flaps with fluorescent substances, including the green CaS. During his experiments, Puluj later developed various fluorescent lamps (Figure 20-9).²⁶²⁶ Otto Lehmann—also began to examine a radiometer during his studies in Kundt's labs in Strasbourg. Lehmann argued that the mill directly changes the energy of light into mechanical work, but only a small part of the energy of light causes temperature differences.

The professor of astrophysics in Leipzig, Zöllner, opposed Crookes' interpretation of the radiometer, although he supported Crookes' spiritism in the 1870s. In 1880 he collaborated with Weber in the development of the theory of electricity and gravity, a few years after Schuster. Zöllner's opinion was close to Reynolds and Schuster's. Zöllner claimed that the absorbed gas stream does not drive vanes of the radiometer, which were

²⁶²⁶ Puluj, 1889, 278–279, 288–289, 284, 290, 293–294).

rotated directly by the evaporations from the solid vane of the mill. In interpreting, he considered the theory of the oscillation of the ether against the electrical theory of rotation of the radiometer. Similar ideas were announced at the same time by Boltzmann's PhD student the English supporter of Le Sage's ether named Preston. One year earlier he criticized the assumption of Crookes and Stoney and argued that the average free path of the molecules in the radiometer is smaller compared to the distance between the flaps.²⁶²⁷

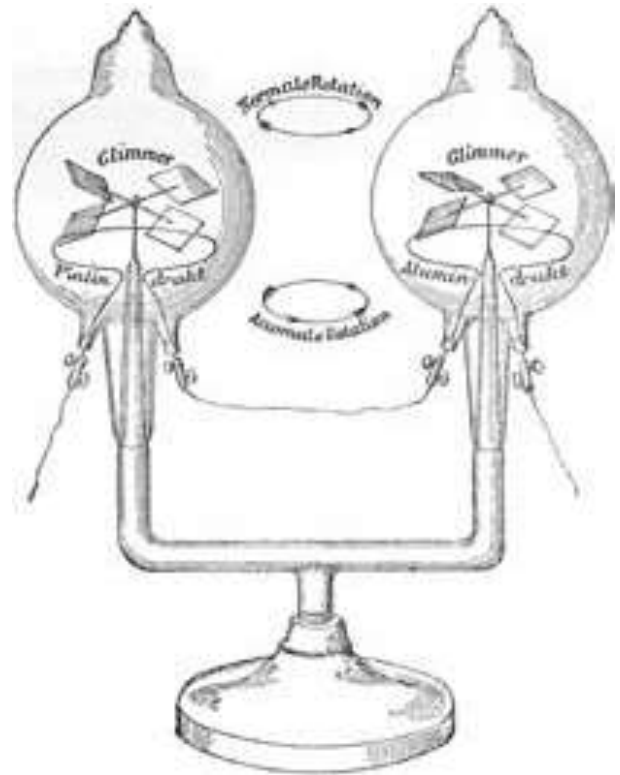

Figure 20-10: Zöllner's double radiometer from 1877²⁶²⁸

The Germans already made radiometers before Crookes, but they did not give them so much attention. Geissler from Bonn presented Zöllner's radiometer at the German Association of Naturalists and Physicians (49. Versammlung Deutscher Naturforscher und Ärzte) meeting in Hamburg on 8-24 September 1876, and later Geissler himself successfully used it.²⁶²⁹

Crookes assembled a double radiometer with counterclockwise blackened flaps on the same axis, which later gained their great popularity. He

²⁶²⁷ Jungnickel, McCormach, 1986, 2: 237; Rosenberger, 1890, 582, 683–684.

²⁶²⁸ Puluj, 1889, 320.

²⁶²⁹ Poggendorff, 1875, 489; Puluj, 1889, 274.

measured the rotation due to heating or cooling, and the pressure which balanced them.²⁶³⁰ Zöllner has compiled a different dual radiometer with short-mounted platinum and aluminium plates rotating around its own axis. At normal pressure, it turned "normally" in the direction of the warmed air flow (Figure 20-10). At a pressure of about 122 mbar, the direction of rotation turned around as if the aluminium and platinum plates were now starting to absorb the surrounding gas. With reduced, then still non-measurable pressures, the direction of rotation was reversed again. At full sunlight, the rotation did not turn even at pressures deep below 122 mbar.²⁶³¹

A live controversy between radiometer researchers continued for several years in the papers of Stoney, E. Pringsheim, Reynolds, Sutherland, and others. Stoney explained the function of the radiometer with a kinetic theory, which was later corrected by Maxwell.²⁶³² However, in the following forty years there were no new important radiometric studies, as opposed to the vivid quarrels in the mid-1870s. The development has stalled more due to the prevailing opinion that the phenomenon is too complicated to be dealt with, and not as the result of a definitive satisfactory clarification. E. Pringsheim of Breslau (today's Wrocław), together with Lummer in Berlin, preferred to undertake research of the radiation of the black body, which was more promising. The radiometer's theory was primarily developed by the findings of Knudsen, who first successfully used the quantitative measurement of the radiometric force to determine the pressure.²⁶³³ It turned out that the impact of a higher speed of molecules is compensated by a smaller free path just above the mill flap. In the thin area above the edge of the flap, however, the effect of faster molecules prevails.

The new Prague professor Einstein provided two comments on Knudsen's kinetic theory at the 1st Solvay Congress. Thirteen years later, in Berlin, Einstein supplemented Knudsen's calculations of forces applied to the flaps of radiometer for the case where the average free path of the molecules is smaller than, or equal to the size of the flaps in the mill.

²⁶³⁰ Ganot, 1886, paragraphs 445, 399–400.

²⁶³¹ Puluji, 1889, 319–328; Brush, 1976, 755.

²⁶³² Wilson, 1987, 192.

²⁶³³ Knudsen, 1910, 633–640; DeKosky, 1984, 98.

20.5 Radiometer, Pressure of Light and Stefan's Law

The pressure of light was discussed already in the 17th century. W. Thomson estimated its size in 1852. Prior to Maxwell, the opinion prevailed that the successful measurement of the pressure of light would confirm corpuscular or longitudinal wave theory, rather than the transversal one. At first, the radiometer seemed to measure the luminous pressure in favor of fans of Newtonian corpuscles. Bartoli of the Institute of Technology in Florence cited the development of a radiometer and assumed that the pressure of light is the result of a thermal radiation which opposes entropy law. His ideas were supported by Eddy who served as the professor of Mathematics and Astronomy between 1874 and 1890, and then President of the University of Cincinnati. Graz professor Boltzmann wrote a review of Eddy's work for *Ann. Phys.* In doing so, the editor E. Wiedemann drew Boltzmann's attention to Bartoli's work, which Boltzmann and Boltzmann's former teacher, Stefan, probably did not even know. As the leading defender of second law of thermodynamics Boltzmann rejected Bartoli's opposition to the entropy law, and he used his description of the pressure of light to derive Stefan's law. The first measurements of the pressure of light only succeeded in the labs of professor Lebedev in Moscow in 1899, and he reported on his success at the International Congress in Paris in August of the following year, as the part of Parisian Exposition Universelle. Three years later, the pressure of light was measured by Gordon Ferrie Hull (1870 Garnet in Canada-1956) and Ernest Fox Nichols (1869 Leavenworth in Kansas-1924) in the Wilder lab of Dartmouth College in US, and more precisely by the German Gerlach and co-workers at the University of Frankfurt in 1923.

20.6 Radiometers in Slovenia

20.6.1 Šantel's Experiments in Gorizia

The grammar school professor, Anton Šantel, described the device for converting the solar heat in mechanical energy as the "solar engine". According to Šantel, the idea was "published in several professional journals in 1874". Šantel used three solid glass tubes with an inner diameter of 1

mm and a length of 4 cm. He fixed them on the rotating cylinder so that he arranged the angles of 60 between them. He filled them up to half with ether and then he exhausted them, sealed and additionally fastened tubes with a wrapper made of muslin fabric. According to Šantel's opinion, "there remained no air except for the vapors of ether" in the glassy tubes. The device was covered with a black layer and he exposed its lower half to the sunlight. Due to temperature differences, the remaining ether in the lower part evaporated more, so that the tubes rotated. Such "solar engine" could propel the clock for several months, as it spun 3-4 times per minute. It rotated faster in cold than in a warm environment. At the end, Šantel estimated the pressure that propelled the vanes.²⁶³⁴

20.6.2 Radiometers in Cabinets for Physics in Slovenian Areas

Radiometers were very popular since firm Leybold The radiometers were very popular since firm Leybold from Cologne put them on sale; Leybold later became a leading vacuum technology manufacturer. At the end of the 19th century, radiometers were acquired at numerous secondary schools at the Slovene ethnic territory. Already in 1880, the collaborator of Eugen Netoliczka (1829-1889) former Krakow professor Adalbert Wachlowski described a radiometer in gymnasium reports in Chernovtsy in today's Ukraine, which were read throughout the monarchy. The radiometers were purchased in cabinets of physics, but due to their fragility, only few were preserved until today, among them in Kočevje grammar school. The Ljubljana grammar school students learned about the functioning of the radiometer in their textbook about physics in a special chapter on the spread of heat by radiation.²⁶³⁵

Radiometer remained interesting for the demonstration in grammar school physics in the next century. Docent Inwinkl, curator of the cabinet of physics of the gymnasium in Koper, decided to buy a Crookes' radiometer in the school year 1906/1907.²⁶³⁶ The radiometers were sold to schools between the two world wars. Five German marks was a price of the ordinary Crookes' radiometer, while a more complicated version with

two opposite black flaps on the same vertical axis was valued 12 marks.

20.7 Conclusion

Crookes and Gimingham improved both the pump and the pressure gauge during their efforts focused on absolute vacuum. On the one hand, they were interested in radiometric, viscous and electrical phenomena related to the theory of matter, and on the other hand, they tried to measure the pressure with these phenomena. With chemical methods they reached a pressure of $5 \cdot 10^{-5}$ mbar, and with the use of seven mercury drop pipes, they've got even $2.6 \cdot 10^{-5}$ mbar in 1884. That remained the record for a decade.²⁶³⁷

The radiometer was the first-class discovery in the 1870s. Later, it turned out that it is not rotating due to radiation pressure, but due to temperature differences. Nevertheless, it remains an interesting physical instrument today.

²⁶³⁴ Šantel, 1883, 40–43.

²⁶³⁵ Wallentin, 1897, 220.

²⁶³⁶ Journal of Grammar school (Izvestja Gimnazije) Koper, 1907, 61.

²⁶³⁷ Ganot, 1886, 181; Redhead, 1999, 139, 144.

IV. Arias: Vacuum for Advanced Industries, Sciences & Entertainments

21 Maintaining the Vacuums: Insulations

21.1 Thermos Flask: the Discovery and Development of Vacuum Insulation

In 1873 Dewar described his vacuum insulation. Twenty years later, the storage of liquid air in Dewar's flasks became the first-class event in science. Today, we use the Dewar's flask renamed to thermos even in the household. First, let us look at the study of the heat transfer through gases and vacuum, and then we'll follow Dewar's path to discovery.

The first experiments with translation of a vacuum were carried out by Guericke around 1654,²⁶³⁸ followed by Boyle and Hooke in 1658. Guericke learned that clocks and musical instruments cannot be heard through a vacuum, while light goes through it. Less convincing were the early experiments with the transfer of heat and electricity.

21.1.1 *Exploration of Heat Transfer through a Vacuum in England of the 19th Century*

In 1785, Morgan announced that vacuum does not translate electricity. Therefore, in 1822, Davy felt that he had a total vacuum available. In February 1838, more careful Faraday did not specify precise measurements in terms of translation of electricity in a vacuum.²⁶³⁹

In 1819, the The Scotsman Leslie separated three ways of heat transfer: radiation, mixing and translation. Before Stefan's experiments, it was not possible to measure heat transfer in gases efficiently, especially not in the vacuum. Therefore, the conductivity of the vacuum was adjusted for thermal phenomena depending on whether they considered heat for a phenomenon like sound or for something resembling light.

Rumford had the sound for phenomenon having the same characteristics as the emitted heat.²⁶⁴⁰ The connection between acoustics and heat was preserved in textbooks until the second half of the 19th century because acoustics was coupled with optics in the treatment of waves. The heat and light were connected after the discovery of the "invisible thermometric spectrum" today named infrared, published by Herschel on 24. 4. 1800. According to Maxwell's (1873) theory of electromagnetic waves, "extracted-radiated heat" has a longer wavelength than visible light.

21.1.2 *Heat Transfer through Gases in Europe of 19th Century: Stefan's Diathermometer*

Qualitative findings on thermal conductivity of hydrogen were first published by Magnus at the Academy in Berlin in 1860 and 1861. However, he still could not measure the thermal conductivity before the habilitation thesis of Friedrich Narr (* 1844 Würzburg; † 1893), defended in Munich in 1870. The first useful results were published by Stefan²⁶⁴¹ using his diathermometer measurements. The diathermometer was like a thermocouple of copper or brass sheet, in which the inner vessel is an air thermometer, while the gas in the narrow gap between the containers is a gauge (Figure 21-1). Stefan used a wall of glass, iron or zinc; sometimes one wall made of zinc, the other one made from iron. The diameter of the cylindrical container was 6-7 cm, in other experiments 32 cm. The distance between the containers was from 2.3 to 5.1 mm. In the last (eighth) Stefan's experiment, the pressure of the intermediate air was reduced to 0.56 bar to prove Maxwell's prediction that the thermal conductivity of air is independent of the pressure.

²⁶³⁸ Guericke, 1986, 45–48.

²⁶³⁹ Faraday, 1952, 513–514.

²⁶⁴⁰ Heilbron, 1993, 121.

²⁶⁴¹ Stefan, 1872, 323–363; Rosenberger, 1890, 672.

In 1875, Winkelmann from Aachen proved the validity of Maxwell's theory down to a pressure of 1 mm Hg. He measured with brass diathermometer of Stefan, in which the distance between the walls is reduced from 1.5 to 2 mm. He recommended observing in a completely glassy container and proved that the vacuum does not translate heat. The results like those were published simultaneously by Kundt and Warburg for diluted gases put between the double walls of the vessel.²⁶⁴²

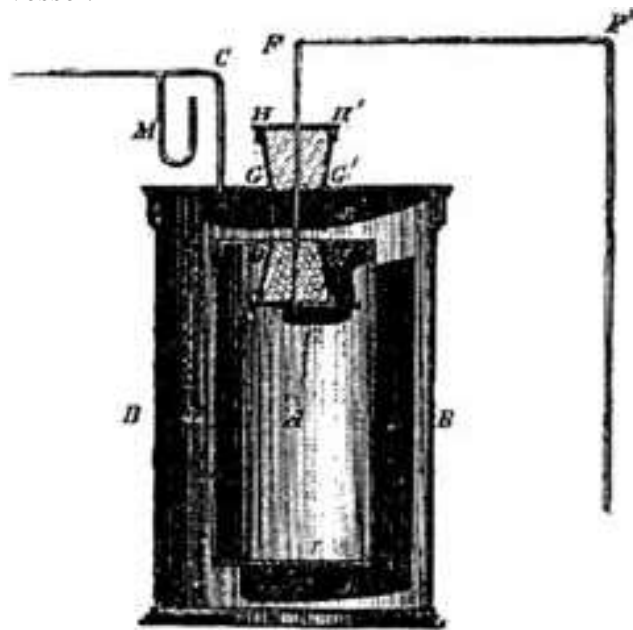

Figure 21-1: Stefan's diathermometer²⁶⁴³

Stefan and his assistant Plank continued with the measurements of thermal conductivity between June 1875 and July 1876 while their work was supported by Boltzmann. On February 2, 1872, in a letter to Stefan from Helmholtz's Laboratory in Berlin, Boltzmann described his "curious expectation" of Stefan's first publication of thermometer measurements. According to Stefan's order, he reaffirmed the correctness of Maxwell's (1867) calculations in contrast to other Clausius' (1862) results. However, soon after Stefan's announcement in 1872, Boltzmann discovered and corrected a calculation error in Maxwell's theory and pointed out that there was no matching of the new results with Stefan's measurements.²⁶⁴⁴

Diathermometer was the first usable device for measuring the thermal conductivity of diluted

²⁶⁴² Winkelmann, 1875, 502, 504, 506, 514; Kundt, 1875, 363–365.

²⁶⁴³ Winkelmann, 1875.

²⁶⁴⁴ Höflechner, 1994, 2: 12, 17; Boltzmann, 1909, 368; Plank, 1876, 215.

gases. Stefan designed that tool in the first half of the 1870s, and at the same time, Dewar developed a similar device as the ancestor of a modern thermos. While Stefan measured the properties of gas placed in a thin gap between two concentric cylindrical vessels, Dewar investigated the substance in the inner vessel. Stefan did not describe his vacuum pump (air extraction device) in 1872; he advised the smoothing and covering of the surface of the vessel to reduce radiation, as Dewar did in his lecture in front of RI during the days of Stefan's death in January 1893.

21.2 Dewar's Invention of Thermos Flask

Dewar was interested in insulations in his early ages when he proposed the use of newspapers to insulate the shoes from the wet Londoner ambient. In the early 1870s Dewar, a lecturer at the Royal Veterinary College in Edinburgh, measured the specific heat of "hydrogenium", the alleged "alloy" of hydrogen and palladium (Figure 21-2).²⁶⁴⁵ In a high-temperature calorimeter, he examined the assumption of Graham and Faraday (1852) about the metallic properties of hydrogen, which was opposed by Dewar's former professor Olding in 1861, while it was advocated by Reitlinger in Vienna.



Figure 21-2: James Dewar (* 1842; † 1923)

The designers of calorimeters used double walls to reduce heat transfer already before Dewar. Dewar has exhausted the space between the walls to further diminish the environmental impact. In September 1872 he published a note on the specific

²⁶⁴⁵ Soulen, 1996, 33.

heat of hydrogen and reported on his measurements with a "specially constructed calorimeter". The following year he published the results of measurements of the physical constants and properties of hydrogen that rejected Graham's assumption of "hydrogenium" by indicating that it was hydrogen absorbed in palladium. Dewar used a calorimeter (A) with a capacity of 0.1 liters placed in the middle of a thick "fully exhausted" brass envelopes. He put the device in a large closed cylindrical container made of tin (E), which was covered by water from the city supply. Unlike Stefan, Dewar did not measure the properties of the gas between the containers, but the substance in the inner vessel. Dewar published a sketch and description of his flask in 1873, and Stefan did the same only two years later (Figure 21-3).

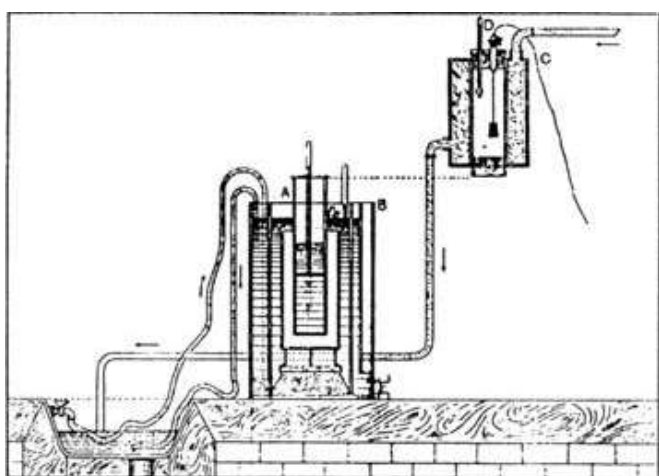

Figure 21-3: The first thermos flask from 1873²⁶⁴⁶

According to its form Dewar's flask did not differ much from the contemporaneous Stefan's invention. The thickness of the space between the containers was 4 to 5 mm in Dewar's design in 1898, which is approximately the same as Stefan used in 1872 and smaller than in Winkelmann's tool in 1875 (Figure 21-4).²⁶⁴⁷

Stefan did not use a diathermometer for the vacuum insulation. He did not lead the fundamental research of the vacuum in Vienna, which he left to Reitlinger and later to Puluj in von Lang's laboratory. Natterer's liquefactions of gases were not continued by researchers of Stefan's school, since the leading Habsburgian researchers of condensation of gases Olszewski and

Wroblewski from the Habsburgian University of Krakow studied in Heidelberg, Kiev and Berlin.

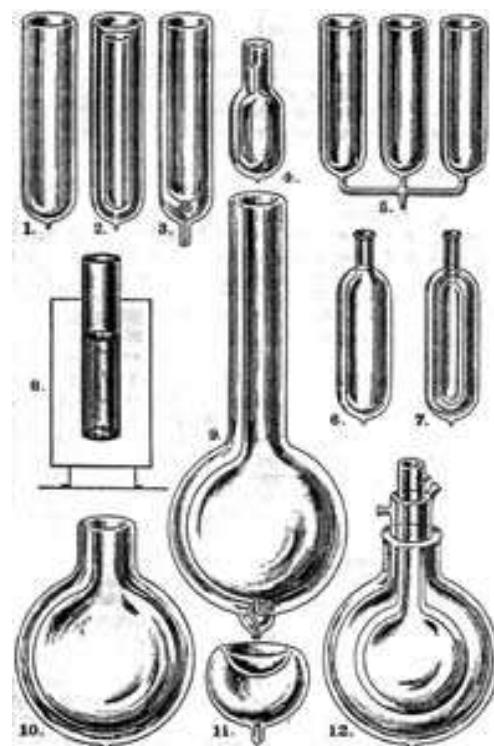

Figure 21-4: Dewar's collection of thermos flasks²⁶⁴⁸

21.3 Dewar in the Liquefaction Competition

At the beginning of the 1890s Dewar replaced the walls from brass with glass to better observe the events in his flasks. The use of metallic walls has been hampered by its higher thermal conductivity, difficulties in polishing the reflecting surface, leaks and gases absorbed in metals and in charcoal. Later, in 1906, he studied liquid air and oxygen at high pressures, which only metallic thermoses withstood.²⁶⁴⁹

In December 1877, Cailletet liquefied oxygen and nitrogen.²⁶⁵⁰ He put calcium chloride between the walls of the cryostat to dry out water vapor which would otherwise condense on the walls of the inner vessel. Despite of their subsequent claims, e.g. on their joint receiving of the Davy medal at Prize Royal Society in London on 30 November 1878, Cailletet and Pictet failed to efficiently produce

²⁶⁴⁸ Dewar, 1927, 127.

²⁶⁴⁹ Soulen, 1996, 34; Dewar, 1927, 1258–1259, 743, 951.

²⁶⁵⁰ They liquefied gases with Joule-Thomson's expansion which Tobias Gruber also researched.

²⁶⁴⁶ Dewar, 1927, 66.

²⁶⁴⁷ Reitlinger, 1861, 17; Dewar, 1927, 694, 782, 63, 66, 653.

enough liquefied oxygen and nitrogen for scientific research because they worked without effective vacuum insulation.

On 27 May 1886, Dewar demonstrated to the President of the RS Stokes and others an experiment designed to solidify oxygen (Figure 21-5). On July 16, 1886, a sketch of Dewar's device was published. In the same year, he projected his device to the screen with the aid of an electric lamp

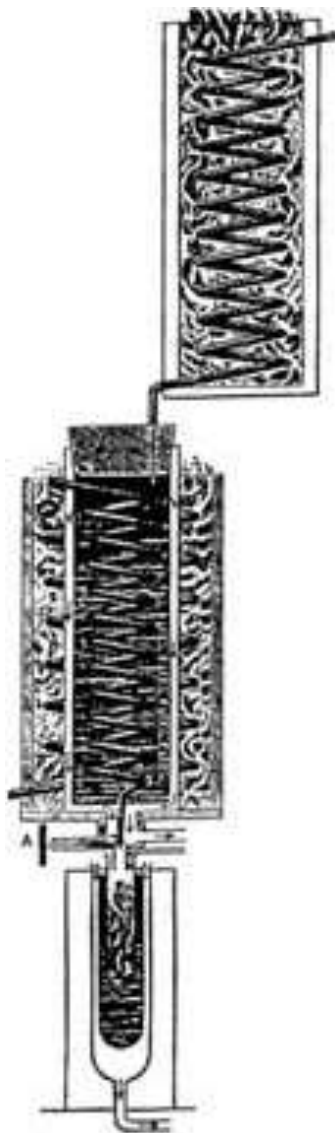

Figure 21-5: Dewar's tool for solidifying of oxygen manufactured in 1886²⁶⁵¹

and a lens in front of the audience in the RS. The condensation and solidification were carried out in separate vessels insulated by vacuum. Crookes radiometer and, basically, Bottomley's experiments, testified to the greatest importance of the role of gas particles in the passage of heat. These studies were more directly influenced by

²⁶⁵¹ Dewar, 1927, 277.

Dewar's experiments at RI at the end of 1892 than Stefan's research. On 20 January 1893, during a lecture in front of RI, Dewar's vacuum vessel was exhausted with a mercury air pump to a pressure of 10 mm Hg. The vessel was heated to 200°C and then the air was forced out with mercury vapors. After cooling, mercury vapors on the walls of the vessel were hardened into a mirror that prevented radiation. Thus, he did not need to silver plate his walls. The prepared vacuum vessel was filled with liquid ethylene, oxygen or air alternately. He measured the volume of gas that has passed through the tube to another container where it was liquefied. The volume of such distilled liquid was in proportion to the heat supplied to the vacuum vessel, which was kept at constant temperature by water. Since the surface of the liquid dropped during the distillation, it was measured only until a quarter of the initial volume was evaporated. Dewar first showed the liquid oxygen that was "calm as water" in the vacuum vessel. Then he released the air between the double walls so that liquid oxygen began to boil. Vacuum insulation reduced the heat transfer by five times.

Table 21-1: Dewar's evaporation rate measurements

Substance	Evaporation rate (cm ³ /min)
liquid oxygen in a sphere surrounded by vacuum	170
liquid oxygen in a sphere surrounded by air	840
liquid ethylene in a sphere surrounded by vacuum	56
liquid ethylene in a sphere surrounded by air	250

Dewar made thermoses of various shapes in which the ice was not collected on the surface of the outer container, even if the vacuum insulation was only 1/2 inch thick. Liquid oxygen or air evaporated only from the surface and no bubbles appeared. Dewar showed a vacuum vessel with silvered walls that reduced the heat transfer "for more than half. In such containers, liquid oxygen or liquid air can be stored for a long time, so that economy and ease of handling are greatly improved". In 1896, he calculated that vacuum insulation with silver plated inner walls reduce the heat transfer by thirty times, while the dry-air insulation reduces the heat

transfer by only by 35%. Nevertheless, the American Charles Eastman Tripler, the Swede Ostergren and Swiss Burger in New York in the winter of 1896/97, developed the principle of self-insulation instead of Dewar's flask. For their insulation they used gas which lost all its moisture during freezing of the air.

21.4 Heat Transfer through Vacuum Insulation at Liquid Air Temperatures

In 1893, Dewar released the preparation results of his evaporation rate measurements from a liquid oxygen vacuum vessel boiling at -180°C .

Table 21-2: Dewar measures the rate of evaporation of liquid oxygen.

Temperature of a Liquid Oxygen($^{\circ}\text{C}$)	Evaporation rate (cm^3/min)
-115	60
-78	120
+6	300
+65	600

The evaporation rate was proportional to the evaporation energy flow. Dewar described the results obtained as "radiation (together with the remaining heat transfer by convection), which increases approximately with the third exponent of absolute temperature. There will be many further experiments before the law of radiation at low temperatures can be precisely defined."²⁶⁵² Dewar's claim was not in accordance with Stefan's law which indicated that the communication between both teams was not the best as Stefan published most of his results in Viennese academic journals.

In 1898, Dewar continued his research of the heat transfer at the temperatures of the liquid air. He measured the time needed to distill equal amounts of liquid air from the three interconnected vessels, insofar as the same shapes and sizes have been used. The insulation of two flasks was filled with different powders, while he left the third insulation of the flask empty for comparison. He found that the additions of charcoal at low temperatures in the

air increase the thermal conductivity, while in the vacuum they reduce the thermal conductivity. The results of the measurements were also influenced by the silvering of the walls of the flask. The experiments were not precise enough to distinguish between three types of heat transfers. He showed, however, that "we can use liquid air to study many important problems of heat transfer". Dewar has ranked low-temperature radiation among the most important fields of his research of the properties of a low-temperature substance besides the storage and handling of liquid gases in vacuum vessels. Already in 1872 and 1873 he tried to determine the temperature of the Sun; he certainly knew the first useful Stefan's calculation of solar temperature published in 1879. In the first five years after that publication of the year 1879, Stefan's law was supported mainly by physicists who published in German language, while the Brits joined them much later. Dewar used Dulong and Petit's radiation studies in 1873, and he supported their finding that vacuum obstructs convection. In 1874 and 1875, Dewar published together with Tait from the University of Edinburgh. In 1884 Tait had not yet mentioned Stefan's radiation law and preferred defending the outdated Dulong-Petit's law. Dewar used Stefan's law to compare it with his measurements only in the years 1920 and 1921.²⁶⁵³

21.5 Disputes about the Priority in the Discovery of Thermos

In 1893, Dewar presented his audience in RI In 1893, Dewar presented to his audience in RI almost a finished invention of his flask, where the basic problem was only the pumping out of a sufficiently good vacuum. Only the discovery of superinsulation was "missing" as it was the only important improvement of the vacuum vessel, which Dewar did not discover himself.²⁶⁵⁴

In 1904, Dewar declared the vacuum as the best insulator of electricity. He thoroughly rejected doubts about his priority, which appeared after the description of his container in the German press in 1894 and 1896. In 1897, Frenchman d'Arsonval announced that he described Dewar's flask for his biological research already on 11. 2. 1888. The German Weinhold tried to make himself a pioneer

²⁶⁵² Mendelssohn, 1977, 53, 56; Dewar, 1927, 128, 267, 277, 353-355, 455, 650, 678, 1117.

²⁶⁵³ Dewar, 1927, 53, 73, 79, 127, 353, 418-419, 652-656, 717, 1000, 1114, 1282, 1299, 1302.

²⁶⁵⁴ Soulen, 1996, 34.

after he promoted some hypnotic Mesmerism on collaboration with Zöllner in 1879-1880. On 15 September 1898, he claimed to describe the same flask in his high school textbook as early as 1881. No one before Dewar used a thermos for the preservation of liquid oxygen, and Dewar's paper was much older than the others in 1873.

On December 12, 1896, Dewar reported in the newspaper Times on German Linde, who patented his device for liquefaction of air in Germany on June 5, 1895. He did not mention the simultaneous independent work of William Hampson (1854-1926 London) patented in England on May 23, 1895. Dewar criticized the professor Tilden of the Royal College of Science, who attributed the invention of Dewar's vacuum flask to Cailletet, like E. Solvay did in his lecture at the Parisian Academy in 1895.²⁶⁵⁵

After several months of experiments, Dewar built a larger tool in which he could condense 20 cubic centimeters of hydrogen in five minutes on May 10, 1898. Hampson protested with a letter published in Nature magazine. At the end of 1894, he supposedly described his device to Dewar's assistant serving in December 1881-1908, Robert Nicol Lennox (* 1861 Killin on Loch Tay in Perthshire in Scotland), which Dewar used without even quoting Hampson. Prior to 4 August 1898, Nature published four Hampson's letters and Dewar's answers to them. Faraday and Dewar did not patent their discoveries, which was not very strange in Londoner academic circles. On the other hand, Kelvin patented many of his discoveries designed in the University of Glasgow, and Dewar collaborated with him on several occasions. Together they worked in the commission, which discussed, inter alia, the determination of the temperature of the Sun in 1873. Thirty years later Dewar wrote to Kelvin about his experiments on radioactivity on August 26, 1903. After World War I, Dewar abandoned the study of low temperatures and devoted himself to the research of capillary surface tension of soap bubbles. Dewar remained an active researcher even when he was eighty years old, with only Crookes still around among his peers.²⁶⁵⁶

21.6 Thermos Flask in Germany and the USA until the Middle of 20th Century

Before WW1 the otherwise unknown glassblower Muller from Coburn used Dewar's silver-plated vacuum milk container to be able to give his child a warm milk in the morning. Muller's and his baby whereabouts were never described in details, but after their successes the thermos flask quickly came into commercial use, first in Germany, then elsewhere.²⁶⁵⁷ The German users of vacuum flasks did not even know they had the invention of Dewar in their hands. The English glassworks were not skillful enough, so, Dewar had to order the production of containers in Germany before 1898.²⁶⁵⁸

In 1898, the German chemist Walter Matthias Hempel (1851-1916 Dresden) announced that the coating of fluff was a better thermal insulator than a vacuum. Similarly, the role of wool fibers in the prevention of air movement was already determined by Stefan and after him by Boltzmann in his discourse on the erection of Stefan's commemorative plaque at the University of Vienna on 8 December 1895. In 1904, Siegfried Valentiner of Halle and A. Bestelmeyer of Göttingen measured internal friction, density and the ratio of specific heat of nitrogen at the temperatures of the liquid air at the Röntgen Physics Institute in Munich. The vacuum insulated vessel which they used was named after Dewar and Weinhold in their discussion. Just before World War I, Dewar explored the cooling of boiling water in his flask, which he had already named "thermos".²⁶⁵⁹

In the years before the Second World War, German companies produced Dewar's flasks with the capacities over 1 liter. They offered cylindrical and round containers with silver plated, coated or ordinary glass walls, also equipped with a support for transport. In the vacuum insulation of metal thermoses, they put charcoal getters. The thermos flasks were used primarily for the transport of liquid air.

²⁶⁵⁵ Dewar, 1927, 879, 455, 781; Linde, 1896, 332.

²⁶⁵⁶ Dewar, 1927, 684, 73; Wilson, 1987, 242; Mendelssohn, 1977, 64, 72-73; Soulen, 1996, 35, 37.

²⁶⁵⁷ Soulen, 1996, 35.

²⁶⁵⁸ Dewar, 1927, 717.

²⁶⁵⁹ Dewar, 1927, 1114, 1119.

21.7 Contemporary Followers of Dewar's Work

Dewar's low temperature research was also described very early in the Slovene popular science journal: "On 19th of December 1896, Dewar explained to the 'Chemical Society' how he condensed air in the emptied round container with strong pressure and heavy frost. He obtained half a liter of frozen air and kept it for an entire half hour in this state. From the beginning, the solid matter is somehow an uneven transparent brawn, a mixture of hard nitrogen and liquified oxygen."²⁶⁶⁰

Dewar's idea was soon used on flat glass structures, which provide excellent transparent vacuum thermal insulation. In 1913, the engineer Alfred Zöller (Zoeller) from Charlottenburg in Berlin patented a hollow glass pane of various shapes, including corrugated glass plates containing separate discharged volumes.²⁶⁶¹ Two years later Zöller patented his electric bulb in Germany and also in the USA after application tiled November 10, 1916.

Zöller's vacuum flat insulation is being developed at the Department of Surface Technology and Optoelectronics of the IJS (until 2003 ITPO) to replace low-cost, but ecologically controversial organic foams. Their uses in insulating houses provide greatest results although the vacuum insulation needs to be occasionally repumped.

²⁶⁶⁰ Simon Šubic, 1901, Dom in Svet, p. 500.

²⁶⁶¹ Zoeller A., 29. 10. 1913. Hohle Glasscheibe (Hollow pane of glass). *German Patent*. Application No. 387655.

22 Maintaining the Vacuums: Bulbs and Stefan's Radiations

With his uses of a light bulb in Edison's Laboratory in Menlo Park, Edison additionally achieved his fame in sciences, backed by his own journal of the same name. W. Thomson described his success with the words: "... no one else is Edison."²⁶⁶² Of course, Edison's work was only a crown of work of numerous researchers during many years.

22.1 The First Light Bulbs

In November 1802, Petrov built a battery with 2100 Cu-Zn elements and a voltage of about 1700 V in St. Petersburg to produce the first stable arc discharge with charcoal. However, next year, his discovery was described only in Russian language. Davy independently came to similar discoveries. In 1802 he noticed that charcoal between the electrodes quickly burns and cannot be glowed in the air like platinum. In 1808 before RI, with a large battery with 2000 pairs Cu-Zn he showed the operation of the arcs and bulbs, which was not developed for practical use. Later in 1853, his former student, Faraday, demonstrated the arc discharge at the Christmas lectures in front of the RI.²⁶⁶³

Until the 1860s no cheap sources of electricity were developed. Nevertheless, bulbs have been patented in many countries, but most inventors preferred arcs. The basic problem was finding a material that did not burn too quickly and there was a puzzle in regulating a fixed distance between the electrodes in the arc. In 1838, in Brussels, Jean-Baptiste-Ambroise-Marcellin Jobard (17 May 1792 Baissey in France– 27 October 1861 Brussels) described a carbon bulb in a vacuum, which was later compiled by his student the engineer Charles de Changy (* 1817 Saint-Avertin in France). Next year Jobard became a pioneer of photography in Brussels. As a child of his times, Jobard was involved in spiritism. However, he had to discontinue the research when the Parisian Academy refused his support, although Jobard became the director of Musée royal de l'industrie in Brussels in 1841. In the same year of 1841, the

²⁶⁶² Friedel, Israel, Finn, 1986, 198.

²⁶⁶³ Petrov, 1803; Bowers, 1998, 64, 67.

Irish politician Frederick de Moleyns patented Jobard's idea as the production of electricity and its application for illumination and motion. The patent did not bring much luck to Moleyns as he was imprisoned for forgery.

The young self-taught genius **Thomas Alva Edison** created his reputation in the US with the rapid transmission of telegraphic and newspaper information during the secessionist war. He exploited the economic boom after the war and with the support of the New Yorker magnates and the press, set up the first industrial research laboratory in Menlo Park, New Jersey, 40 km southwest of New York in the winter of 1875-1876. Among other things, he continued to research telegraphy, supplemented Bell's phone and set up a phonograph later renamed to gramophone. Above all, he created the light bulb industry, which he triumphally victoriously resettled him to New York as the leading inventor and businessman after five years of continuing research at Menlo Park. Tesla tried to do the same in Colorado Springs but did not master enough funding to stay there long enough.

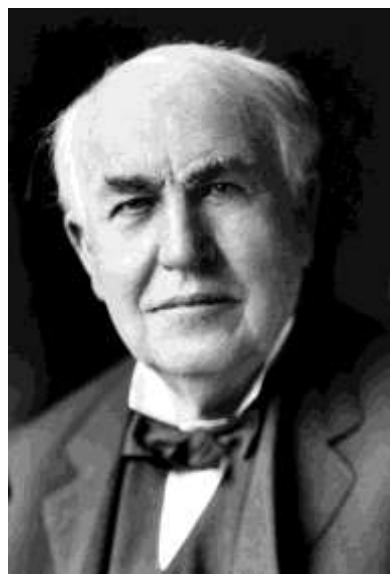

Thomas Alva Edison (* 1847; † 1931)

In 1840, Grove burned platinum in air and other gases, even for use in mines. Both types of lamp, filled by platinum or carbon, were patented by American Starr, who traveled throughout England and France with his business associates the local Cincinnati daguerreotypist John Milton Sanders and latter USA Union Army colonel Edward

Augustin King to propagate his discoveries of incandescent lamp and generator patented in USA in 1844. His incandescent light bulb in a vacuum over the mercury column blackened too quickly despite of renewable carbon strip, but his description in the book *Repertory of patent inventions* influenced Swan's research. In the revolutionary year of 1848, the German emigrant Heinrich Goebel (Henry Göbel, * 1818 Springe of Lower Saxony in Germany; † 1893 New York) left for the United States where he used a galvanic battery to glow a platinum wire in a vacuum above the mercury barometer in the year 1858. By lighting the window of his watch shop in New York, he attracted customers; for his novelty he received 15 patents in 1882s, and he also studied the electric arc lightings. In 1882 he patented improvement of the Geissler's system of vacuum pumps and he solved a puzzle of connecting carbon-filaments and metal-wires in a light bulb. Starr and Goebel's merits were used against Edison's bulb patents, but Edison proved to be too strong for those challenges at the courts and in media. Unfortunately, Goebel's invention was soon forgotten until he became a Nazi legend promoted as the inventor of an electric bulb in 1938.²⁶⁶⁴ The Nazi minister of propaganda Joseph Goebbels probably loved Goebel because of their similar family names.

In 1872, Lodigin described a carbon-filament vacuum bulb between brass electrodes. The following year, the streets of Petersburg were lightened. He put in some other fillers in his bulb, replacing them after they burned for about half an hour. In November 1874 he received the Lomonosov Prize of the Academy of Sciences, but next year, due to financial difficulties, he continued his research abroad. In January and February 1876, three Lodigin's lamps illuminated the Petersburg stores, and dozens were bought by the Parisian Workshop of pioneering photographer Jules DuBoscq (1817-1886). In the summer of 1873, Edison purchased DuBoscq's electric arc lightings lamps for his laboratory in Newark,²⁶⁶⁵ but did not express much interests for his Russian competitors. In September 1874, the Petersburg bankers and electricians established the society

«Товарищество электрического освещения Лодыгин и К^о» to sell and patent Lodigin's invention of electric lightings on initiative of Petersburg banker Степан Александрович Козлов (Kosloff). Козлов's former collaborator now a Warsaw resident Станислав Викентьевич Кон (Kon, Konn, † 1876) soon joined them and demonstrated the abilities of Lodigin's bulbs in Germany and France until his premature death. The descendant of generations of highest Russian navy officers, the head of electricity department of Admiralty (начальник электрической части Адмиралтейства) lieutenant Bouliguine (Николай Павлович Булыгин, * 1847 Petersburg; † 1912 Crimea) joined them with his official capacities and inventions. But all of them were no match for Edison.

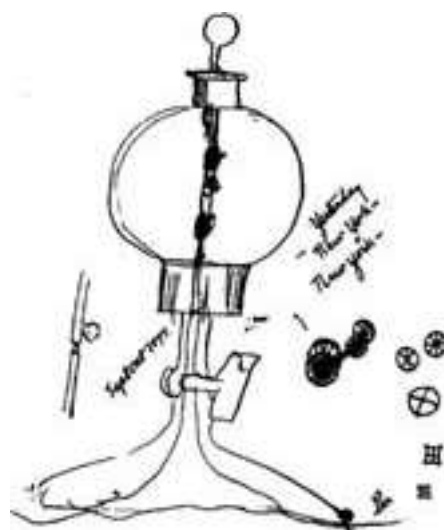

Figure 22-1: Edison's light bulb in September 1877, as he memorized and painted it a year later²⁶⁶⁶

22.1.1 Edison's Bulbs

Since the autumn of 1874, Edison ordered Crookes' *Chemical News* for his laboratory, so they also monitored the progress of vacuum technology.²⁶⁶⁷ At the end of January and early February 1877 Edison began his research of bulbs and continued to explore electric arc lightings and bulbs between September 1877 and January 1878 (Figure 22-1). In the lab, he had a Gassiot's cathode ray tube since 1875. In the middle of September 1877 Edison ordered Charles Batchelor to insert a piece of charcoal into it. Since it was

²⁶⁶⁴ Dittmann, 2007, 150, 153, 155, 158; Grove, 1845, 442–446; Siemens, 1957, I part, 87; I. Šubic, 1897, 128–129; Friedel, Israel, Finn, 1986, 7–8, 94, 115; Bowers, 1998, 69–70.

²⁶⁶⁵ Edison, 1991, 45.

²⁶⁶⁶ Edison, 1994, 546.

²⁶⁶⁷ Israel, 1998, 93, 102.

difficult to get small enough pieces of charcoal, they used preloaded paper, which was also used for their parallel surveys of the phone. When the cathode ray tube was sealed again, it was exhausted by a conventional air pump purchased in March 1875. The resulting vacuum was poor, so that the charred charcoal was burning almost as fast as in the air. That's why they prefer the glowing silicon and boron. The lamps were connected in series and at the same times in parallel, which later led to a successful lighting system.²⁶⁶⁸

Henry Draper provided the first photography of the solar spectrum. His father, J. W. Draper, studied at the University of London, then emigrated to the United States and became famous for his research of the luminescence in New York. In 1878, Edison was heavily exhausted after intensive research of telegraphy. For this reason, he accepted the invitation of leading American scientists the physicist Barker and astronomer Draper. They asked him to provide them with a tasimeter²⁶⁶⁹ to observe the total solar eclipse in western United States. The journey took place from July 13, 1878 to August 26, 1878. They spotted the British Wallace's laboratory in Ansonia, Connecticut. William Wallace, together with Moses Gerrish Farmer (1820-1893), designed the dynamo that he had been producing since 1875. During Edison's visit, Wallace dealt with the construction of a powerful electric generator "Telemachon" and a system of arc-shaped lighting with carbon plates.²⁶⁷⁰

Just a few days after returning to Menlo Park, Edison knew that he could provide a major improvement in electrical lighting. He also intended to use his experience in distributing telegraph pulses to provide the powered electrical lighting for individual users. The current electric lamps were only useful for strong public lights, while for the individual users, gas lighting was still dominant. Edison planned to adapt gas lighting edifices to his new electrical light bulbs²⁶⁷¹ by changing the fuel while keeping the same old

designs like the first automobiles resembling carriages pulled by horses or the modern web books. Following the ambitious statements for the New York Tribune on September 28, 1878, Edison's reputation attracted the magnates from Wall Street to the creation of the Edison Electric Light Company (EELC) on October 17, 1878.²⁶⁷²

The self-taught Edison was well-known in scientific circles, but he refused to hire academically trained scientists for a long time. Only under the pressure of J. Pierpont Morgan and other EELC directors he was required to recruit American physicist Francis Robbins Upton (1852 Peabody-1921 Orange New Jersey) in November 1878. Upton finished Bowdoin College in Maine, graduated from Princeton with the very first Ph.D. promoted there, and then advanced his specialization in John Hopkins University and in Helmholtz's labs in Berlin. As a mathematical-technical consultant, Upton, collected literature and patents about the electrical lamps for Edison during his first year, until he devoted himself to experiments and later to managing the production of light bulbs.²⁶⁷³ Upton mathematicised Edison's ideas as Maxwell mathematicised Faraday's insights in the same time.

Draper also supported Edison in the American Association for the Advancement of Science (AAAS) and in the more elite NAS along with Rowland. When he later took over the AAAS presidency in 1883, Rowland changed his mind in defense of the academic exclusivity. Edison was just not one of his own. In a famous call for pure science, in contrast to most American (Barker) and British (W. Thomson, Crookes) researchers, Rowland said that Edison's research of an electric bulb is not science, just like the new cooking recipes are not chemistry.

Barker met Edison in 1874 at an exhibition at Franklin Institute. On 3. 11. 1874 he invited him in writing to present his inventions to the NAS. As Assistant Editor of Am. J. Phys. and the Chairman of AAAS he addressed Edison and Upton to prepare their own papers for the AAAS meeting in Saint Louis in 1878 and in Saratoga Springs in 1879.

²⁶⁶⁸ Edison, 1994, XXXVI, 540–547.

²⁶⁶⁹ Tasimeter was designed for the measurements of the heat of stars and solar corona .

²⁶⁷⁰ Friedel, Israel, Finn, 1986, 6–7.

²⁶⁷¹ Friedel, Israel, Finn, 1986, 13.

²⁶⁷² Bowers, 1998, 93, 95.

²⁶⁷³ Israel, 1998, 612.

Until 1884, when he focused primarily on marketing, Edison first founded the Telegraph Journal, and then the Science magazine on 3. 6. 1880. For one and a half years he financially supported the Science magazine. The Science devoted two pages and a half to electricity research, and specifically reported on the work of Edison's Laboratory. Thus, in the first volume, Upton's report on the pilot railway at Menlo Park was published. After Edison, the support of Science magazine was taken over by the inventor of the phone, Alexander Graham Bell.²⁶⁷⁴ In the 1880s, Edison supported electrical engineering courses in schools with thousands of dollars.

22.1.2 Vacuum Bulbs

During their first months of exploration of lamps in Menlo Park, Edison and his boys primarily searched for suitable radiant materials. Instead of tungsten, charcoal and iridium which Farmer praised in New York on October 7, 1878, they selected platinum. Moses Gerrish Farmer never profited much from his discoveries because of his spiritualist religious reasons resembling Crookes, but Edison did not have such limits. Platinum was expensive, and the electrical current had to be regulated through it by means of relatively complicated return loops, to prevent its heating above 1769°C. The platinum hardly oxidized, and Edison initially avoided the use of a vacuum around his platinum filaments, of course not because of Aristotle's fear of empty.

Edison's laboratory boys used a microscope to study the bubbles and leaks on the materials, which was a novelty in industrial research. By weighing they found that platinum became lighter after heating. Edison assumed that gases in the pores of platinum leave metal and cause damage after heating (Figure 22-2). On February 2, 1879 Upton led the experiment and assumed that hydrogen was mainly adsorbed in platinum. The undesired gases were evaporated by preheating the platinum in vacuo and re-pumping before the bulb was sealed. Therefore, in January 1879, they began to explore in a high vacuum, which they could no longer avoid. Unlike his predecessors, Edison used better technology, especially Sprengel's mercury pump.²⁶⁷⁵

²⁶⁷⁴ Hounshell, 1980, 612; Edison, 1991, 328, 778.

²⁶⁷⁵ Madey, 1984, 14; Friedel, Israel, Finn, 1986, 46, 49, 51, 53

On January 1, 1879, Edison telegraphed in vain to his friend Barker at the University of Philadelphia and the first president of Stevens Institute of technology in Hoboken in Jew Jersey Henry Morton (1836 New York –1902 New York).

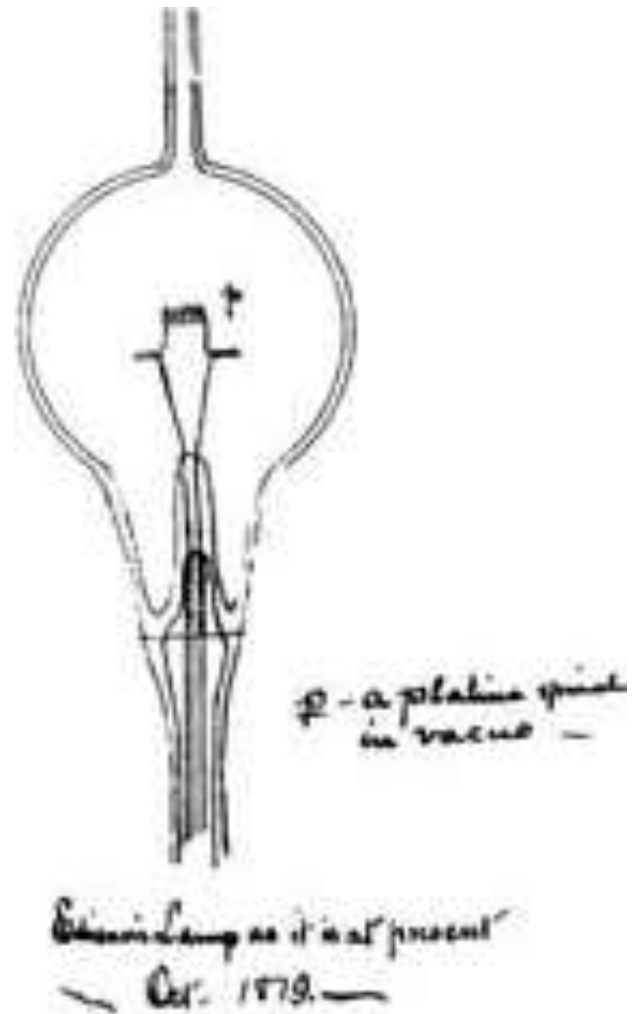

Figure 22-2: A platinum-filamented lamp that did not work well in October 1879.²⁶⁷⁶

Edison asked them to send him Sprengel's pump. Therefore, Edison initially pumped with a mechanical pump, in which the vapor pressure of the seal oil used was even surpassed the residual pressure of vapours of mercury.²⁶⁷⁷ Edison's highly capable mechanic Krüsi was unfortunately unable to compile Sprengel's pumps. On 26 March 1879, Edison received a Geissler's pump by Albert Reinmann and Williams Baetz from New Yorker glassblowing firm Reinmann & Baetz, and at the same time, Edison got another one from former Upton's professor Cyrus Fogg Brackett (1833 Parsonfield, Maine-1915) of Princeton, but that one was corrupted although Brackett was famous

²⁶⁷⁶ Friedel, Israel, Finn, 1986, 87.

²⁶⁷⁷ Edison, 1991, 375; Hablanian, 1984, 19.

for his manufacturing skills. The master glassblower William Baetz of Albert Reinmann & Baetz firm from New York also helped and arrived several times in a few months to help installing his device in Menlo Park. But he did not want to work with Edison, who, in 1878, hired Boehm, a glassblower formerly working at Geissler's manufacture in Bonn.

Johann Heinrich Krüsi was born in Heiden, Appenzell in Switzerland. He worked as a mechanic in Zurich and Paris. In 1870 he worked on Singer's sewing machines in New Jersey and moved to Edison's firm in 1871 or 1872. His name was cordially Americanized to John Krusi (Cruz). In 1882 he was responsible for production at Edison's first central station in New York.²⁶⁷⁸

In 1878 in the *Annales de Chemie et de Physique* William de la Rue and Hugo W. Muller published a paper about the combination of the Geissler pump with Sprengel's pump and described McLeod's vacuum measuring instrument. Geissler's pump was faster, while Sprengel's pump gave a better vacuum. In mid-August 1879 Boehm's pumps reached a tenth of Pa and were probably the best in the world. In a little more than a year Boehm produced for Edison more than a fifth of the total exceeding five hundred pumps for the Menlo Park bulb factory (Figure 2-3). The Sprengel-Geissler pump design of Edison's laboratory was used until 1896. Unfortunately, Boehm and Tesla were among the few arrivals who could not adapt to the atmosphere at Menlo Park and Boehm left Edison in October 1879.²⁶⁷⁹ Boehm worked for Edison's competitor Maxim, returned to Europe and came back to the USA to establish his own firm. On 12 April 1880 the chemist Dr. Otto A. Moses made for Edison a vacuum pump with a closed bottom and apertures on the side to reduce the mercury pressure to the bottom. Without warming, it could get a good vacuum in five hours, which was very time-consuming part of pumping bulbs process.²⁶⁸⁰

²⁶⁷⁸ Edison, 1991, 633–634.

²⁶⁷⁹ Israel, 1998, 180–181, 193.

²⁶⁸⁰ Friedel, Israel, Finn, 1986, 61, 62, 159, 163, 251; Hablanian, 1984, 19.

Edison published experiments in a vacuum under his own name, which was one of the reasons for the later Upton's anger. A spiral filament of platinum of 0.005 inch of diameter and a mass of 266 mg lost 8 mg after an hour and half of glowing in hydrogen fires, while the second spiral filament of platinum of 343 g lost 42 mg after 9 hours of flaming. After 20 minutes, a thin layer of mirror on the glass walls was noticed. After 5 hours, the platinum spiral was no longer visible through the accumulated thin layer on the walls.

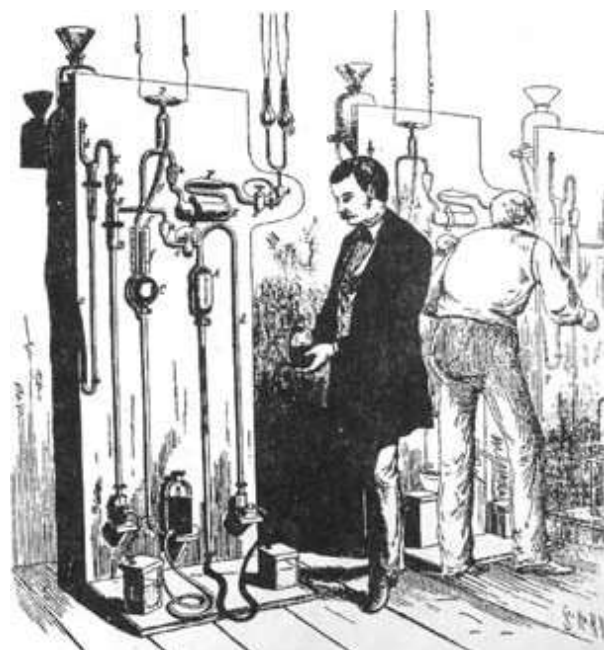

Figure 22-3: Production of vacuum lamps in Menlo Park in 1880²⁶⁸¹

When the spiral thread was covered with MgO after the magnesium acetate was burned, MgO was accumulated instead of platinum on the surrounding glass. Thus, Edison was convinced that the sputtering phenomenon was caused by gas resulting from the platinum of the spiral. The loading of the metal on the walls of the vessel could not be prevented even with a vacuum of 2 mm Hg. Only Sprengel's pump helped, when half of centimeter long spark from the induction coil was no longer able to pass through a 1 mm wide vacuum.

When the 0.02 mm thick platinum wire was glowing in the Bunsen's burner, it melted somewhere and got a "zigzag" shape. At four times thicker conductor, this did not happen because the

²⁶⁸¹ Friedel, Israel, Finn, 1986, 131.

higher radiation of the surface did not allow such high temperatures. After heating, Edison observed many cracks on the conductor under the microscope. After 20 minutes, the cracks could also be observed with the naked eye, and after a few hours the conductor was broken. The phenomenon was noticed by J. W. Draper and the French chemist Tessie de Motay, who burnt platinum in hydrogen vapour.

When Edison realized the cause of the breakdown of the conductor, he protected it by pre-annealing in a vacuum. He got a very homogeneous and solid platinum without gas bubbles and a high melting point. He produced several platinum spirals with a radiant surface of 3/16 square inches which were glowing with 4 candles at the melting point. Then the air was pumped to 2 mm Hg. The spiral of the conductor was slowly heated by electrical current to the red glow and cooled at intervals of 15 minutes to remove gases from the pores and replace them with metal. After 100 minutes, the spiral was illuminated by four candles, which would normally melt up the platinum. It gave even 30 candles at very slow warming. Under the microscope, there were no cracks on the smooth silver-white spirals, which thinned down during the process and it was very difficult to melt it. From a surface of 1/32 square inch, resembling a grain of buckwheat, he received a lightness of 8 candles, eight times more than without pre-heating in a vacuum. With less than a horsepower, he could supply 16 such lamps with a luminosity of 128 candles.

Edison tested different metals. After its treatments by that described procedure, the iron became as solid and elastic as the glass, and it lighted better than ordinary platinum, while the aluminium has only melted in a white glow, etc.²⁶⁸²

22.1.3 Parallel Discoveries during the Edison's Research of the Bulb: Lamp Survey

In mid-December 1878, Upton discovered that when the bulb resistance is as high as 200-300 Ω , no additional energy is required, since it depends only on the glowing surface. Therefore, the extremely light glowing filaments were used in the light bulb, which were extended by curling the

spiral. The invention was patented in England in February 1879.

In 1879, Edison began using a vacuum to extract gold from very pure ores.²⁶⁸³ It was a kind of modernized amalgamation using physics instead of chemistry.

Even after success with his bulb, Edison continued his experiments in a vacuum. In 1884 he declared and on 18 September 1894 he obtained a patent for coating with evaporation in vacuum by straight heating with a direct current, which he called "electro vacuum deposition". Nevertheless, the discovery of thin layer in a vacuum by resistant heating of platinum conductors is often ascribed to Nahrwold's three-year later work in which Edison was not mentioned. Nor did Kundt mention Edison when he used that discovery to determine the refractive index of thin metal layers in the following year in 1888.²⁶⁸⁴ Edison was just not a part of academically trained community and academicians tried to ignore him as the outsider. Edison certainly disliked such treatment which sounded like the invalidations of his patented rights.

By the end of July 1885, Edison applied for three patents for the adsorption of mercury and water from a vacuum with special tubes filled with different getters. In addition to assistant John Otto, another woman Mina born Miller (1865 Akron in Ohio-1947) worked on that experiment. She proved to be so good that the widowed Edison married her on February 24, 1886. In December 1889, the colleague William Kennedy Laurie Dickson demonstrated to Edison the moving images he illuminated with the bright light of the Geissler's cathode ray tube.

Edison used the sputtering with high voltage alternating current, which he most likely accidentally discovered at higher pressures when he explored the carbon lamp. In 1900 he declared his discovery and received the patent for the "Phonograph plates overlay procedure" on 18. 11. 1902. Edison's National Phonograph Company used Edison's patent to sputter thin films of gold on

²⁶⁸² Edison, 1879, 152–154.

²⁶⁸³ Israel, 1998, 341–342.

²⁶⁸⁴ Waits, 1997, 18.

phonographic cylinders made of wax between 1901 and 1921.²⁶⁸⁵

The sealing of the lamp was particularly difficult with conductors made of lead. Swan and other researchers did not demonstrate their achievements in this field, so the problem was probably solved solely by Edison's group. Initially they had sealed with wood in Menlo Park, and they began using gypsum from Paris in 1881.²⁶⁸⁶

22.1.4 Carbon Filament Bulbs

Better vacuum re-opened the option of replacing platinum with cheaper charcoal. In October 1879, in Menlo Park, parallel to the research of the bulb, they also dealt with the production of telephone transmitters for the British market. In this way, a lot of charcoal of drum in the phone was available and it was also tested in the bulb. On October 21, 1879, a light bulb with charcoaled cotton thread was lit, which according to the legend was burning for 40 hours, although laboratory notes testify only 30.5 hours. On 4 November 1879, a patent application was filed, which only had to wait for 84 days. In a written request, Edison wrote: "I discovered that even the cotton thread, appropriately greased and placed in a sealed glass container, exhausted to a millionth part of atmosphere, gives a resistance of 100 to 500 Ω of to current and is completely stable at very high temperatures."²⁶⁸⁷

Simon Newcomb was born in Wallace, New Scotland. In 1884, he became a professor of mathematics and astronomy at the John Hopkins University in Baltimore. The University of Leiden awarded him the Honorary Doctorate. Together with the later Nobel Prize winner Michelson from the Maritime Academy, Newcomb was then in the middle of preparations for measuring the speed of light with an interferometer. Edison had such a reputation among American scientists at the time he invited Michelson to place his interferometer in Menlo Park. Michelson cordially refused the invitation.

²⁶⁸⁵ Israel, 1998, 255, 296, 315; Waits, 1997, 19; Mattox, 2000, 3.

²⁶⁸⁶ Friedel, Israel, Finn, 1986, 116, 171.

²⁶⁸⁷ Madey, 1984, 14.

On 6. 12. 1879, Edison's group used charcoal in the form of a horseshoe. In mid-January, Newcomb as the head of the Nautical Almanac Office at the Naval Observatory in Washington informed Edison that the luminous intensity of the bulb could be greatly increased by using a more homogeneous and more solid form of carbon than greased paper. Edison followed the advice and explored a lot of different of substances. He sent an expedition to India, China, Central and South America with American entrepreneurship onboard. "He started with countless experiments and searched for the right material for the carbon filament and he really found it after thousands and thousands of failed searches in Japanese bamboo whose burnt fibers proved useful."²⁶⁸⁸ The story might not be completely true because Edison also wanted to impress his investors and customers, as well as his competitors.

Morton criticized his New Jersey neighbor Edison's bulbs in the Sci. Am. In the United States, European criticism of Edison's arguments also echoed. There, Faraday's RI graduate student William Henry Preece (1834 Bryn Helen, Caernarvon, Wales-1913) and Hippolyte Fontaine even mocked Edison's "distribution of electric current" or power, which was impracticable.²⁶⁸⁹ Preece also criticized Heaviside and Maxwell's electromagnetic theories while he backed Marconi's radio. Hippolyte Fontaine was equally important as he helped to organize the Parisian International Exposition of Electricity with first international congress of electricians in 1881.

Henry Augustus Rowland from Honesdale, Pennsylvania, studied at the Polytechnic Institute in Troy, New York until 1870. In 1872, he became an associate professor there, and two years later he became a full professor. After completing his studies at Maxwell's class and four months at Helmholtz's lab in Berlin, he returned to his own laboratory at John Hopkins University in Baltimore in 1875, where he became a full-time professor of physics in 1881 and remained in that position until his death. In 1883 he became president of AAAS, in 1889 FRS, and in 1893 he was a member of AR. He was an unsurpassable producer of diffraction gratings.

²⁶⁸⁸ Poljšak, 1931, 34.

²⁶⁸⁹ Nye, 1983, 34.

George F. Barker from Charlestown, Massachusetts, became assistant to B. Silliman the elder in 1858. Between 1859 and 1861, he taught at the Harvard Medical School in Boston. Since then, he taught natural science at Wheaton College, Illinois in 1861, and the following year he lectured on Chemistry at the Medical Academy in Albany, New York. In 1863, he received his doctorate in medicine. In 1864 he went to Pittsburgh, Pennsylvania, where he became a demonstrator in 1866, and the following year he was a professor of chemistry and toxicology in New Haven, Connecticut. From 1873 he was a professor of physics at the University of Philadelphia. In 1872 and 1879 he was President of AAAS. He was also the assistant editor of *Am. J. Phys.* and he took care of promoting Edison's discoveries among scientists. Eight years after Rowland, Einstein's future teacher Heinrich Friedrich Weber (1843-1912) professor of applied physics at ETH in Zurich, published a procedure for measuring all the properties of Naccari's protegee Alessandro Cruto (1847-1908 Torino) and Edison's bulbs filled by carbon or platinum except for their longevity. Helmholtz presented Weber's experiments based on J. Stefan's formula under the title *Untersuchungen über die Strahlung fester Körper* to Prussian academy on July 26, 1888. Einstein's uncle and father certainly read it as they were in that same bulb business.

Cyrus F. Bracket and Charles A. Young from Princeton published in *Am. J. Sci.* a commendable estimate of Edison's lamps after an independent research commissioned by Edison. In April 1880- in the same magazine, one hundred pages in front of them Edison's friends Barker and Rowland published another favorable assessment of the efficiency of the Edison lamp,²⁶⁹⁰ measured as the ratio between the consumed part of the generator and the obtained luminosity. Rowland and Barker did not have any usable dynamometer, and the brightness of lamps could not be easily measured at long distances. They could also measure its resistance and current through a single bulb, but also did not have the necessary devices for such a measurement. Therefore, they placed the bulb under the water in the middle of a calorimeter so that the water around it could be mixed. The criterium was the heat emission per minute. The

temperature was measured precisely up to a tenth of a degree Celsius with Baudin's thermometer, while a calorimeter made of a very thin copper held about 1.25 kg of water. The measurement was accurate to 3% because they did not consider radiation. With a calorimeter temperature close to the air temperature and low heating, they reduced the error to 1%.

Two bulbs of almost identical power were used. They measured only one, while the other was stored in the calorimeter and they replaced each other for the next measurement. They compared the brightness with a regular Bunsen burner, which lit one candle at the distance of 10 inches.

The measured bulbs with straight lines of greased paper were shining much more in the rectangular direction. Therefore, they also measured in the direction parallel to the surface and used average results. The bulbs had a mass of about 35 g. For the horsepower used they obtained 1000 to 1500 candles, which was promising if they could produce enough cheap and long-lasting light bulbs.

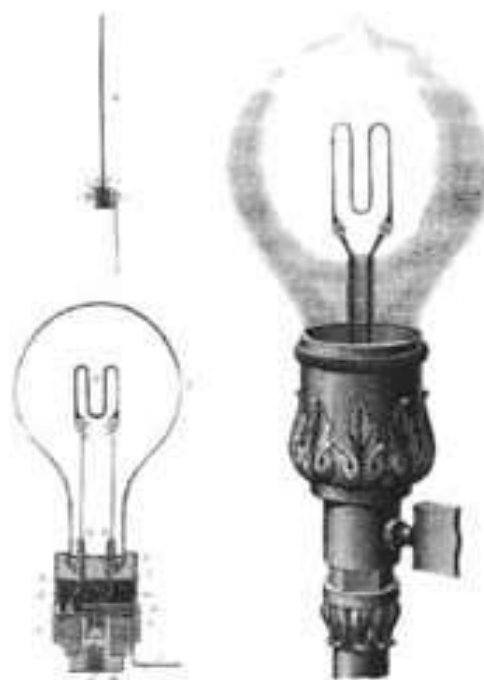

Figure 22-4: Maxim's light bulb at the Viennese Exposition of 1883 where J. Stefan lead the reviews of inventions.²⁶⁹¹

African American Lewis H. Latimer also worked for Maxim with a decent salary. He designed the improvements of lighting. Nevertheless, he later moved to Edison's firm, but despite the successes

²⁶⁹⁰ Israel, 1998, 465; Friedel, Israel, Finn, 1986, 138-139.

²⁶⁹¹ Urbanitzky, 1885, 404.

of the Bell's parallel phone, he suffered from racism. In the late 1880s, Brush's company set up electric arc street lighting at Broadway, New York, and Maxim started selling bulbs like Edison (Figure 20-4). Barker praised Maxim's invention in the press, shown at the NAS meeting in late 1880 in New York. Perhaps he did a favor to Maxim for the resentment because Edison ignored his request to equip the famous Draper Laboratory with his own lamps.²⁶⁹²

Charles Francis Brush of Euclid, Ohio, received a diploma of mechanical engineer in 1869 at the University of Michigan, and then he studied at the Western Reserve University in 1880. In 1878, he invented his own version of the electric arc lightings. He founded the company "The Brush Electric Co & The Linde Air Products Co." In 1878 that company was the first in the US to produce a useful dynamo that was part of the lighting system.

In January 1881 in Menlo Park, for example, they decided to manufacture bulbs under Upton's supervision a quarter of a mile away from the laboratory. The factory employed over 150 people. On 19 April 1881, the group of New York City Councilors secured the privilege of the Edison's Company bulbs, which was the beginning of their worldwide success. Upton's place of Edison's mathematical-technical assistant was taken over by Charles Lorenzo Clarke (1853 Portland Maine-1941 Portland Maine) who became the first president of board of directors of Edison Company for Isolated Lighting in 1882.²⁶⁹³ For the most appropriate voltage Edison chose 110 V,²⁶⁹⁴ which remained the standard in the US and disturbs a lot of Europeans who bring the European-made notebook or shaver during their visit to USA (without an adapter).

After serving at the CCE, from where he was sent to Strasbourg in early 1883, Tesla went to Edison to New York next year with the recommendation of Paris friends and Batchelor. He worked there

²⁶⁹² Lewis, George 2005. Book Review: Rayvon Fouché, *Black Inventors in the Age of Segregation*: Granville T. Woods, Lewis H. Latimer, and Shelby J. Davidson, *ICON*, 11: 228-230, here p. 229; Hounshell, 1980, 613.

²⁶⁹³ Nye, 1983, 100, 123; Friedel, Israel, Finn, 1986, 194, 195, 207.

²⁶⁹⁴ Siemens, 1957, 1: 88.

until the spring of 1885, and then he founded Tesla's street lighting company. The following year he completed his own lighting system with arcs, which was soon described in the Slovene language: "If we link two metal plates that stand opposite each other, with Tesla's currents, then there are very strong electric forces in the entire space between them. Geissler tubes, which we bring into such a space, immediately flash off. This behavior of Geissler's tubes gave birth in Tesla's hope that it might be possible to introduce a new, all other covering electric lighting. In the space that we would like to enlighten in this way, we would be inserted into two opposite walls of a large metal plate and tie them with Tesla's currents. Then, at each end of this space, a Geissler tube would illuminate, which would be freely, without wire, transmitted and placed in any place. Sadly, we are still far from this ideal lighting."²⁶⁹⁵

Hiram P. Maxim from Maine initially worked as an engineer developing the scientific devices, and he studied the bulbs after 1877. He was one of the founders and chief engineer of the United States Electric Lighting Company, which initially produced electric arc lightings, then platinum bulbs filled with the air, and since 1878 the graphite vacuum bulbs. He invented a thermostatically regulated short circuit in the case of excessive heating of the lamp and a "flashing" process of heating charcoal in a hydrocarbon vapor where extra charcoal was applied. The characteristic form of the letter "M" was written on the filament element after his surname. After 1883, he shifted production to rifles and aviation navigation.²⁶⁹⁶

After 1886 with his basic bulb patents expired, Edison quickly began to withdraw from the production of light bulbs so that he could use his time for other inventions. In 1893, the Edison and Swan patents expired and with them the monopoly position of their company.

The price of light bulbs fell rapidly by more than three times, and new manufacturers began to take on the market. Among them, Hirst was the most important. He prepared himself at the end of the Edison Patent monopoly by visiting bulb factories

²⁶⁹⁵ Šubic, 1897, LXIV; Dadić, 1982, 305.

²⁶⁹⁶ Bowers, 1998, 98-99.

in Germany, Austria, and the United States. In Vienna, he met C. J. Robertson, who previously worked for Lane-Fox. They were set up by Robertson Electric Lamps Limited, which was owned by GEC (General Electric Company) by half, while others were distributed by individuals. They bought Hammersmith factory that had worked for Brush before, and soon became the most important manufacturers of light bulbs in Britain. In the beginning of 1892, Edison Electric Company merged with Thomson-Houston in General Electric Company. Edison was greatly affected by the fact that his name had been withdrawn from the company's name and, most probably, he therefore started his research metallurgy, to surpass his success in the bulbs.²⁶⁹⁷ The main competitor of GE was Westinghouse, who founded a research laboratory in the United States in 1916 and soon added a light bulb on the agendas. In the Soviet Union, they established the first laboratory for the discharge research in 1918 in Nizhny Novgorod. The following year they started producing the electronic valves.

Hugo Hirst (Hirsch) was born in Altenstadt, Bavaria, in the family of owners of a successful distillation company. In 1880, he moved to London and changed his surname to Hirst, and later became Lord of Witton. He worked for Power Storage Company for several years and then joined General Electric Apparatus Company of another Bavarian emigrant Gustav Binswanger (1855-1910 Hampstead in London), who hanged his surname to Byng later. In 1889, Hirst was granted British citizenship, and the company was renamed General Electric Company Limited (GEC). In 1919, he set up a research center, one of the first focused on bulbs in the UK. It was officially opened by J. J. Thomson and Lord Robert Cecil in February 1923. Six physicists, two chemists, two engineers, and one metalworker out of a total of 29 workers, worked at the laboratory, including the later famous Paterson.²⁶⁹⁸

22.1.5 Tungsten Lamps

The charcoal bulb lighted nly by three watts, therefore they searched for substances with a higher melting point. Edison tested the glowing

material from charcoal particles mixed with rare earth oxides patented in March 1897.²⁶⁹⁹ Nernst's experiments with MgO only later turned out to be the predecessor of a fluorescent lamp. Siemens rejected it, but AEG bought its patent for £ 50,000 to avoid threatening competition. The tungsten with the highest melting point among metals was promising, but in the 19th century they did not know any of its alloys, which could be hammered.

The Viennese native **Karl Auer baron Wiesbach** was the son of a simple clerk who excelled through his education to become the director of imperial printing office. Karl Auer studied chemistry in Reitlinger's class in Viennese Polytechnic and in Heidelberg where he assisted Bunsen. He accidentally discovered that some salts gave a bright light after heating in a gas burner. Ten years later, he successfully researched lanthanides. In 1892, at the assembly of aeroengineers and hydro-engineers in Kiel, he showed a new possibility of street lighting with a Bunsen burner which glowed a cloth of cotton fabric, soaked in thorium nitrate, doped with cerium and then burned. In 1901 he became baron von Welsbach after the manor, which he bought near the Treibach chemical factory north of Klagenfurt in Carinthia.²⁷⁰⁰

The problem was solved by the Croatian Hanaman from Denovec in the county of Županja, who studied chemistry in Vienna and Berlin. In 1900, he became an assistant to Augusto Vierthaler's (1838 Vienna-1901 Trieste), the Triestino student of Professor Georg Vortmann (Giorgio 1854 Treste-1932 Barcola (Barkovlje)) at the Chemical-Analytical Institute of the Viennese Technical College. The similar post was provided for Dr. Alexander Friedrich Just (Just Sándor Frigyes, 1874 Bremen-1937 Budapest), who also worked for Eugene II Schneider's (1868 Le Creusot 1942 Paris) firm Schneider-Creusot (Schneider & Cie, Schneider et Consorts) on the improvements of carbon filament lamp. Hanaman helped Alexander Just, but Hanaman determined that only metal filaments with the highest melting point can be considered for the light bulb in 1902. From a mixture of chlorine and WO_3 , $WOCl_4$ was obtained, evaporated ,and reduced with hydrogen

²⁶⁹⁷ Israel, 1998, 337, 339.

²⁶⁹⁸ Bowers, 1998, 107–109, 146, 171.

²⁶⁹⁹ Israel, 1998, 337.

²⁷⁰⁰ Bowers, 1998, 127.

to pure tungsten. The new bulbs patented in Germany in April 1903 were much more economical than carbon filaments, but they were fragile, and they could not get 100 V and 16 candles. They later produced tungsten, pressed in a hydraulic press. The resulting lamps were lit up over 400 hours with the power of 1 W. The professor of electrical engineering at the Viennese Technical College Carl Hohenegg (1860 Vienna-1942 Vienna) published the photometric measurements of their device.

Hirst's negotiations with Siemens & Halske were not successful, so they signed a contract and worked at Egyesült Villamossági es Izól-lámpa R. T. in Ujpest.²⁷⁰¹ Hirst immediately sent his technician to the negotiations in Budapest, but he himself visited Hanaman and Just to introduce their process to Britain. In the meantime, he heard of Welsbach's success with an osram bulb, and in the United Kingdom he founded Osram Lamp Works with a Hammersmith factory and equivalent shares of Hirst, Welsbach, Just and Hanaman. Production began in 1909 and soon showed the advantages of tungsten compared to the osram,²⁷⁰² which is the alloy of osmium and tungsten. Hanaman later became the first professor of inorganic chemical technology and metallurgy at the Technical College, later the Technical Faculty in Zagreb. As Mayor of Zagreb, he worked for the city's electric lighting.

After five years of experiments, Auer-Gesellschaft first began manufacturing a lamp with a metal element in 1906. A 0.09 mm thick Osram wire with a length of 28 cm gave one candle at power of one and a half watt, more than twice the amount of carbon lamp. However, even the tiniest of them had only a small resistance. Thus, only 16 to 44 V could be used and had to be connected in series to a 110 V line, which was of course embarrassing.

Charles Proteus Steinmetz was born in the German Jewish family in Breslau (today's Wrocław). He was a socialist and, due to political problems, he went to Switzerland and then changed his original name Karl in the US.

²⁷⁰¹ Fox, Guagnini, 1999, 270; Bowers, 1998, 121; Dadić, 1982, 302–303.

²⁷⁰² Bowers, 1998, 147–149.

In January 1905, Siemens & Halske began selling the equally effective tantalum bulb developed by Bolton. Before World War I, tantalum light bulbs were very well placed on the market, as they sold 50 million of them even in 1914, when the bulbs with tungsten filament developed by GE began to push them out from the market. In 1906, Auer-Gesellschaft began to sell Osram bulbs where they replaced the osmium with tungsten, that has a higher melting point and therefore only needs a little over 1 W for a candle. The tungsten powder was mixed with charcoal to the conglomerate from which the wires were drawn and finally the charcoal was removed. In 1919, AEG, Siemens & Halske and Auer's AG combined the production of light bulbs in Osram GmbH KG in Berlin.²⁷⁰³

In GE's laboratories, they were also aware of the shortcomings of carbon lamps when the director electrochemist W. Whitney and consultant mathematician Steinmetz took over the development after their studies in Germany. In 1904, the General Electric Metalized (GEM) bulb was marketed, and Whitney improved the incandescent lamp with pre-heating of carbon between 1905 and 1908.

In 1909, at GE in Cleveland, Ohio, Coolidge patented the production of tungsten that could be pulled into thin wires, which did not hang down. The tungsten was usually doped with sodium silicate or aluminium at the level of 100 to 150 ppm. The tungsten powder was heavily heated and compressed into the shape of a stick, which, however, was still fragile after cooling. At 1000°C, it was pierced with diamond tips until it became flexible and it could be stretched first in warmed and then in colder state into wires with high toughness.

Coolidge developed powder metallurgy in a completely controlled manner and quickly laid the foundations of the tungsten lamp industry. In the 1970s with the transmission electron microscope (TEM) they found that material doping creates a series of empty spaces (pores) with a radius of 5 to 100 nm. Pores are placed along the sample during treatment; they are thermally stable and permanent. With mass spectroscopy it has been shown that the pore contains potassium which is not soluble in

²⁷⁰³ Siemens, 1957, 1: 284, 286, 288, 290, 2: 32; Dadić, 1982, 302; Fox, Guagnini, 1999, 270; Bowers, 1998, 150; Rosenberg, 1915, 318.

tungsten. After heating, they create high pressure vapors, which cause the pores to rise to a uniform size. In the halogen and study bulbs, at the highest temperatures near the melting point of the tungsten (3410°C) the pores move and tend to aggregate, which is in accordance with the notion of free energy. Some come to the surface where their break release potassium vapor; this can develop a hot stain that destroys the bulb.²⁷⁰⁴

The American **Coolidge** from Hudson, Massachusetts, graduated from MIT in 1896, then moved to the Physics Institute led by G. H. Wiedemann at the University of Leipzig in 1898. He studied electrical waves in conductors and received his doctorate in Leipzig in 1899 with the author of the basic electronic theory of metals Drude. In 1901, Coolidge became a full-time professor at MIT, in 1908 he became assistant director, and in 1932 he was director of the research laboratory GE in New York. In 1913 he became famous together with his assistant Langmuir. They used tungsten for anode in the "Coolidge X-ray tube" with a heated cathode in GE.²⁷⁰⁵

In the GE laboratory, they were initially engaged in the development of a mercury lamp. Later, GE's director, Whitney, improved the charcoal fiber properties in the melting furnace and provided the promising market for his company for several years. Nevertheless, in the following years, the competition forced GE to buy patents from Siemens. Therefore, since 1906, they have failed to test the metal fibers in the bulb until Coolidge override the competitors by using tungsten. GE regained the market again.

In 1913 Langmuir examined the basic characteristics of the bulbs and cooled the filament. He found that the radius of the bulb does not have a major influence at all. He investigated the bulbs filled with nitrogen and then switched to argon atmosphere in his bulbs. Thus, at the end of the 1990s, GE had already managed 96% of the bulbs market in the United States.²⁷⁰⁶

²⁷⁰⁴ Siemens, 1957, 1: 115, 290–291.

²⁷⁰⁵ Siemens, 1957, 2: 79; Fox, Guagnini, 1999, 268; Bowers, 1998, 145–146, 150.

²⁷⁰⁶ Fox, Guagnini, 1999, 268; Schopman, 1988, 141–146; Bowers, 1998, 150 .

On 7 December 1915, Edison patented the production of a tungsten electrode by pressing tungsten powder in an oxygen-free vacuum container. He evaporated tungsten by "discharges between electrodes". The resulting thin leaves of tungsten or tantalum were cut into strips, twisted into rollers around a soft metal or wax and bent into the horseshoe shapes for bulbs. A similar product was also obtained by direct coating of the melting core of wax with tungsten.²⁷⁰⁷ In the first decades of the 20th century, Edison's bulb with tungsten reached a form that we are still using today without major changes.

22.1.6 *Bulb in England, France, and Italy*

Due to the multiple scams the English Parliament voted in 1881 a sharp law called the Lighting Act. It supposedly protected people from excessive promises of electric lighting companies. Later, the law greatly damaged the development of domestic lamp production and raised doubts about the powerful propaganda of Edison's lamps in the US.



Figure 22-5: Swan light bulb at the Viennese exhibition in 1883²⁷⁰⁸

At Exposition Universelle in Paris in 1878, they admired mainly Jablokov's electric arc lightings, and three years later Swan's lamps, Edison, Lane-Fox and Maxim's products excelled at the International Electrical Exhibition from August to

²⁷⁰⁷ Waits, 1997, 19.

²⁷⁰⁸ Urbanitzky, 1885, 402.

Swan was initially a chemist and pharmacist in his native Sunderland. After the deaths of the owners of his company *Hudson and Osbaldiston* he joined the manufacturing chemical business of his brother-in-law John Mawson in Newcastle-Upon-Tyne, where they developed electric lighting and photography after 1844. In 1845 Swan was impressed with the perspectives of a bulb during William Edwards Staite's lectures on arc lamp, platinum-iridium lamp and Grove's experiments at his home areas of Sunderland and Newcastle, just as happened to Faraday a little earlier in London. After 1846 Staite collaborated with William Petrie who studied in Cape Town and Frankfurt. Staite patented his clockwork or spring system which provided fresh carbon for his bulb on November 12th, 1846. Swan began to test his own bulbs in 1848, but due to poor vacuum he failed to succeed. In 1867, Mawson died in the explosion of nitroglycerine used for his photographing and his widow Elizabeth took over his share. When he became acquainted with the Sprengel pump in Crookes' discourse of 1875, Swan finally designed a workable lightbulb. Swan's associate, the banking officer Charles Henry Stearn (1844 Jamaica-1919), improved it in Birkehead with an added mechanism for lifting silver and preliminary mechanical pumping. On July 12, 1879 in *Sci. Am.* Swan published a paper on the carbon lamp, which Edison re-examined several months later. After his doctorate, Swan became president of the Literary-Philosophical Society in Newcastle-upon-Tyne. He invented bromine paper, which is still used today in black and white photography.²⁷⁰⁹

November 1881. Edison made some mistakes while preparing lamps for the exhibition, but his people in Paris wrote newspaper articles in his favor. In fact, his light bulbs were slightly more effective than the others. In 1881, at the exhibition in Paris, the Parisian academicians Henri Édouard Tresca (1814 Dunkirk-1885 Paris) and the secretary of the department of experiments at the exhibition Jules François Joubert (1834 Tours-1910 Paris) performed one of the first measurements of the energy conversion efficiency

²⁷⁰⁹ Bowers, 1998, 70, 87–91, 103; Israel, 1998, 217.

of thirteen devices using direct current, mostly focused on the bulbs and electric arcs. Two years later their work was at the Viennese exhibition under the leadership of Stefan.²⁷¹⁰

Immediately after the Parisian exhibition, Edison founded three companies in Paris in 1882; their descendant *Compagnie Continentale Edison* was still active in the next century. Unfortunately, the gravest financial crisis in Paris has ruined the initial capital and successes of Edison's factories around the city. In 1884, they founded *Società Italiana Edison*, initially to illuminate the wealthy downtown center of Milan.²⁷¹¹ The Parisian International Electrical Exhibition was followed by similar exhibitions in London and Munich in 1882, in Vienna in 1883 and in Philadelphia 1884.

22.1.7 *The Bulb in Germany and the Netherlands*

On June 5, 1873, Siemens and Halske's company received an English patent for the automatic regulation of electric arc with charcoal, powered by DC or alternating current. In April 1877, W. Siemens published a paper on electric lighting of the Frenchman Serin who constructed the lighthouse of Havre with electromagnetic machine of Floris Nollet in 1852. By 1880, Siemens developed a metal filament lamp, like that of Edison. On July 21, 1877, Alexander, the nephew and assistant to William Siemens in London, visited the laboratory at Menlo Park. Nevertheless, they later did not take part in the development of the bulb, as Edison tried to disable Siemens's patent of dynamo with Rowland's support in the US, as Siemens's ideas resembled Edison's own dynamo.²⁷¹²

After the crisis that was caused by the collapse of the stock exchange in Vienna on December 27, 1881, Siemens lectured before the German Electrical Association on the advantages of electric lighting compared to the gaslighting in relation to the danger of fire. Among the inventors of the incandescent light bulb Siemens listed de Changy from Paris, Jobard, Swan and finally Edison. Siemens & Halske used compressed carbon and

²⁷¹⁰ Boncelj, 1960, 54; Urbanitzky, 1885, 412; Bowers, 1998, 86–87.

²⁷¹¹ Fox, Guagnini, 1999, 283–284; Bowers, 1998, 109.

²⁷¹² Edison, 1994, 457; Hounshell, 1980, 615.

graphite surfaces, where the heating depends on the thickness of the glowing rod (Figure 20-6).²⁷¹³

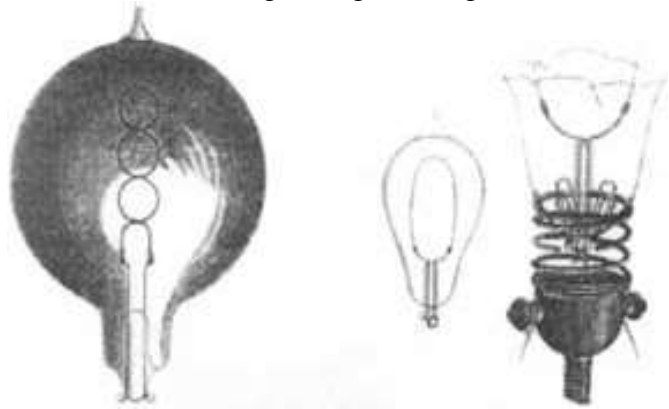

Figure 22-6: Siemens & Halske's light bulb at the Viennese exhibition in 1883²⁷¹⁴

Many emigrants who returned from the United States after several years working at Edison's Menlo Park helped to set up the new electrical industry in Germany. Among them was Sigmund Bergmann (*1851 Tennstedt; † 1927 Berlin), an inventor of an improved selenium photoelement in the year 1931. Francis Jehl (1860 New York-1941 Florida) joined Edison at Menlo Park a few days before Upton and later he updated the Edison system in Habsburgian monarchy, France and Romania. Another Edison assistant, John Krüsi, stayed in the US and supervised machine work in Schenectady, where GE developed later.²⁷¹⁵

The greatest successes in using Edison's patents in Germany was achieved by engineer Emil Rathenau, born in 1839 in Berlin. He studied in Hannover and Zurich and then specialized in England. He became interested in the light bulb at the first Parisian electrical exhibition in 1881. In the spring of 1882, he was already very successful at the international electric exhibition in Munich. Unlike his competitors, he did not challenge Edison's European patents, but began to work under Edison's license, thus exploiting Edison's experience. On 13 March 1883, he signed a contract with Siemens & Halske, so he could raise the necessary capital to set up the Deutsche Edisongesellschaft für angewandte Elektrizität with a capital of 5 million mark on 19 April 1883 and began to supply very small electrical installations, as the company Siemens & Halske

did before him. In 1897, Rathenau's company was renamed Allgemeine Elektrizität Gesellschaft (AEG), which was independent of the Paris Compagnie Continental Edison.²⁷¹⁶

In 1891, Friderik Philips founded the company NV Philips' Gloeilampenfabrieken in Eindhoven in the Netherlands with his son, engineer Gerard Philips. Their initial capital was 150,000 guilders. Although there were already four other bulb factories in the Netherlands, they soon produced 500 light bulbs per day. His younger son, Anton Philips, who worked on the London Stock Exchange a few years earlier, preferred to join the company as a successful seller. After a favorable contract with Russia, the annual sales exceeded one million light bulbs in 1898. The following year Friderik retired and his sons became equal owners of the company. In 1903, in Berlin, the manufacturers of light bulbs from Germany, Austria-Hungary and the Netherlands, together with Philips, signed the foundation of the Verkaufstelle Vereingter Glühlampenfabriken (VVG), the first international cartel for carbon filament lamps.

Gerard Philips graduated in mechanical engineering at the University of Delft. During his work in the Glasgow shipyard he became acquainted with electric lighting. W. Thomson enabled his position at the university there after he had already begun to illuminate his house in Glasgow with light bulbs in 1882. Before he returned to the Netherlands, G. Philips worked briefly in London's British Company and for the Berlin AEG.²⁷¹⁷

In November 1911, Anton Philips returned from inquiring trip focused on Coolidge's light bulbs in the US. He brought with him trained workers and in December he started producing tungsten lamps. So, he was able to end his old sintering²⁷¹⁸ procedure in July 1912 and arrange with German companies on the right to produce tungsten filled lamps. In 1912, Philips had about 6 million guilders of capital. It was not until the First World War that Philips got rid of the German influence and Philips began to produce all parts of the bulb

²⁷¹³ E.W. Siemens, 1891, 321, 344, 454, 462–463.

²⁷¹⁴ Urbanitzky, 1885, 406.

²⁷¹⁵ Nye, 1983, 78, 87.

²⁷¹⁶ Siemens, 1957, I, 89, 91, 92–93, 95; Bowers, 1998, 109–110.

²⁷¹⁷ Bowers, 1998, 110, 146–147, 161.

²⁷¹⁸ Bowers, 1998, 150.

independently. Philips built factories in Belgium, Spain, Switzerland and Poland; and he even gained a share in Sweden.

In Eindhoven, Gerard Philips had been continuously studying in his own laboratory, although he formally established it only later. In his laboratory in Eindhoven, Heinrich Hertz's nephew, GL Hertz, has been researching since 1920 to receive his Nobel Prize in Physics in 1925. During the war, Philips began producing amplifiers and televisions. Philips family gained their influence in science and penetrated with the systematic training of their technical assistants and by installing well-equipped laboratories. In the production of light bulbs, Philips became the third most powerful in the world after GE and Osram, while GE controlled 96% of the US market in 1928.²⁷¹⁹

22.1.8 *Bulb in Habsburgian Monarchy*

The company Siemens & Halske already established a branch in Vienna in 1858, which was primarily concerned with railways. Due to unsuccessful business, the branch was abolished in 1864 after Halske's efforts. In 1879, W. Siemens opened a technical office in Vienna with a small factory that, in addition to railway signaling devices, soon started small and large lighting installations, production of dynamos and arcs. In 1896, the Viennese subsidiary of Siemens & Halske, at its own expense, set up a small provisional power plant in Ljubljana. For advertising, they illuminated the premises of the Narodni Dom which was officially opened in October.²⁷²⁰

The Englishman **George Lane-Fox** failed with his first two light bulbs in 1878 filled with a platinum alloy and iridium or asbestos impregnated with charcoal. In 1880 he began to use French grass (French whisk, bass broom), which he processed in hydrocarbon steam and then carbonized. His patents were later bought by Anglo-American Brush Electric Light Company.

In 1873 Edison did not participate in an international exhibition in Vienna, although a member of the US Commission urged him to present his inventions at least in the report.²⁷²¹ At the first international electrical exhibition in Paris in the spring of 1881, the electric arc lightings were still competing with light bulbs. Edison and Maxim from the United States and Swan and Lane-Fox from the United Kingdom²⁷²² were among the outstanding lamp manufacturers. In 1882 Edison hired Austrian electrical engineer Dr. Hermann Claudius from the Austrian telegraph for arranging, mapping and converting main and replaceable resistors in the lower Manhattan area along the Brooklyn Bridge. Claudius collected data on complaints about gas lighting disadvantages that promoted sales of Edison's light bulbs.²⁷²³ In 1889, Claudius published in his domestic Viennese Zeitschrift für Elektrotechnik a paper About the calculation of heat in electric waveguiding for practitioners (Ueber die Berechnung der Wärme in Elektrisch-Lichtleitungen für Praktiker).

Moses G. Farmer of Massachusetts began to test platinum lamps in 1858, and he examined the graphite rods between the carbon blocks in a nitrogen atmosphere after 1877. In July 1878, together with Barker and John William Draper's son Henry Draper, Moses G. Farmer visited Menlo Park.²⁷²⁴

William E. Sawyer, a telegraphist and journalist from Washington, DC, began collaborating with a wealthy lawyer, Albin Man, in 1878. Independently of Maxim, they developed the stopper lamps and a "flashing" process. In collaboration with Westinghouse they were selling their patents to most of the light bulb companies in the US, but not to Edison, who was their main competitors in the US.²⁷²⁵

After the Parisian exhibition in 1881, Edison illuminated opera in Paris, Berlin and Milan thus enabling a resounding start to sell his products in

²⁷²¹ Edison, 1991, 508.

²⁷²² Fox, Guagnini, 1999, 125.

²⁷²³ Friedel, Israel, Finn, 1986, 206.

²⁷²⁴ Israel, 1998, 164.

²⁷²⁵ Bowers, 1998, 99–100; Israel, 1998, 188.

²⁷¹⁹ Siemens, 1957, 2: 33.

²⁷²⁰ Siemens, 1957, 1: 105.

Europe. In 1882 Edison's boys lighted up the theater in Brno.²⁷²⁶ That same year, Edison's company participated in the electrical engineering exhibition at the crystal palace in London, and from 11 August 1883 at the 3rd International Electrical Exhibition in Vienna, whose technical-scientific manager was Stefan. The exhibition was attended by the electrical engineering company Geba from white Ljubljana. Several electrical technicians from Slovenian countries were members of the Electrotechnical Society on March 5, 1883.

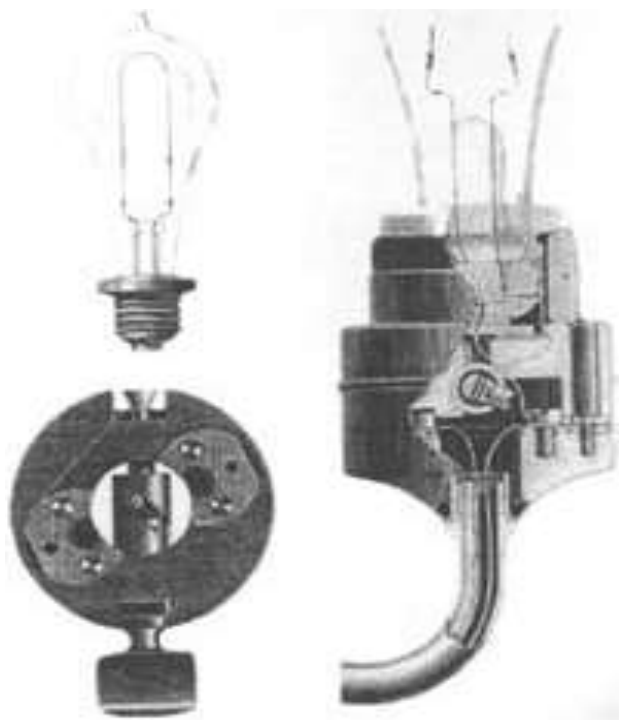

Figure 22-7: Edison's lamp at the Vienna exhibition in 1883²⁷²⁷

The exhibition in Viennese Rotunda on 33,000 square meters with 400,000 candles of electric lighting was until then the largest in the world.²⁷²⁸

A total of five types of electric bulbs were exhibited. Edison's bulb contained a glowing bamboo with a diameter of 1 mm and a length of 12 cm in the form of an inverted letter "U" (Figure 22-7). The hardest part of the production was the inserting and sealing of both conductors from platinum into the liquid mass of the glass. Both ends of the conductor were separated by plaster. The electrical current from the Edison machine was supplied by the Pardon Armington's (1836 Pawtucket-1901 Massachusetts) steam engine.

²⁷²⁶ Boncelj, 1960, 13.

²⁷²⁷ Urbanitzky, 1885, 399.

²⁷²⁸ Boncelj, 1960, 34, 35.

With the Edison's lamps of CCE and SEE (Société Électrique Edison) under the guidance of Viennese firm Brückner, Ross & Consorten they illuminated the "Hall of Arts" and the interior of the premises at the Viennese Exhibition.

In Swan's bulb, the platinum carriers of charcoal were isolated from each other on the lower part of the glass pillar. They were used at the exhibition to illuminate the Imperial Pavilion, theater and interior spaces. Swan's products were represented in Budapest by United Electric Lighting Company (UELC) from London, and in Vienna by the firm of Bernhard Béla Egger (* 1831 Buda; † 1910 Vienna) and the Zionist Johann Kremenezky (Kremenetzky, Josef Josefowitsch Leibensohn, * 1848 Odessa; † 1934 Vienna) & Co.

The Maxim's lamp had a glowing section in the form of a rounded letter "M" worn by two platinum conductors, sealed in the glass. The glass pear was in a metal bowl, sealed with plaster. The bulb of the volcanic or other insulator was wound around the metal core. The air was pumped out with a mercury pump and the vapors of oil were exhausted to 40 mm Hg.

Lane-Fox's lamps contained glowing charcoal in the form of a horseshoe. At 66 V and 0.673 A, they gave 8.7 candles. They illuminated a part of the "Art Theater", the interior spaces, the garden and the pavilion of the British Commission in Vienna. Brush's machine supplied their electricity.

Siemens & Halske's company exhibited a bulb with charcoal filament shaped as horseshoe pressed in a tube-shaped covering made of copper, which was extended into the glass through a platinum conductor.²⁷²⁹

The Prague Professor Puluj exhibited a portable lamp in a box of wood and ebonite in the size of 20 × 25 cm, powered by the electrical current of six Bunsen elements. The bulb on the front of the box was wrapped with a strong protective glass and behind it he put a small metal mirror. A lamp weighting 7 kg provided 6 to 7 normal candles during 6 to 7 hours. For the ministry of war interested in mines and diving, Reitlinger's successor at Viennese polytechnics Friedrich Wächter presented lamps weighting only 300 g.

²⁷²⁹ Urbanitzky, 1885, 397–406.

J. Stefan took a special active part in the 3rd Section of the Scientific Commission, which investigated dynamo machines and electric lamps. On 18 September 1883 they were convoked for the first time to elect for Stefan's deputy the professor Erasmus Kittler (1852 Nurnberg-1929 Darmstadt) from Munich recently resettled to the first chair of electro-technique in Darmstadt. The head of the subsection responsible for machines became the major Obermayer as former Stefan student and later biographer, and the professor Ernst Voit (1838 Speyer-1921 Munich) from Munich became a secretary and head of the sub-department for photometry.²⁷³⁰

On 18 October 1883, Stefan gave a lecture on the goals and results of the work of the scientific and technical commission. Just four years after Edison's invention Stefan presented the facts of Edison's vacuum lamp to the Viennese mayor Eduard Uhl (1813-1892) with his municipal representatives. Even the patron of the exhibition the Habsburgian Crown Prince Rudolf was present just after the birth of his only legitimate daughter Elisabeth on 2 September 1883. Rudolf sadly passed away five years later. Stefan explored the vacuum lamp as an example of his theory of radiation. At the same time, he inherited the useful ideas of his teacher Ettingshausen and emphasized the advantages of the bulb against other sources of light. Wächter and Puluj, the members of Stefan's Viennese physics institute, also showed their vacuum bulbs at the Viennese exhibition under Stefan's leadership. Puluj had already taken over the chair in Prague, but he kept in contact with Viennese vacuum researchers. Stefan has valued the capacity of bulbs for several years after the Viennese exhibition. He knew that the very experiments with radiation in vacuum bulbs will help recognition of his theory of radiation; modern experiments fully justified his hopes. He described the course of measurements of resistance and current, which were especially common in approvals of designed lightening. The parallel photometric measurements enabled Stefan to provide a transparent table of the dependence of the light power on the energy consumed. A light emitting diode diagram showed that higher voltage reduces thermal radiation and thus increases the economy of the bulb. At the end of the lecture he described the advantages of an electric bulb before

lighting gas or candles.²⁷³¹ Unmarried Stefan often worked late into the night; of course, he knew very well the importance of a good light bulb.

In Stefan's lab, the efficiency of the lamp was measured using the version of the Siemens electro-dynamometer, called "ergometer". Stefan's commission issued a total of 177 certificates in German language, among them 22 for bulbs. The last one was signed by Stefan in the middle of 1885. On 3 November 1883 the exhibition was closed in Vienna. Senekovič described it to the people of Ljubljana, who was by far the most appropriate for that job. He was the professor of Physics between 1874 and 1884, director of the 1st Ljubljana Gymnasium (and libraries) until his retirement in July 1907, the president of the Carniolan Museum society in Ljubljana and the author of textbooks about physics in 1883 and 1892. He reported: "... I am pleased to mention that the best recognized among the light bulbs were constructed by the Austrians, namely the Slavs ... While the arc lamp sends light produced between its charcoal to all sides, the light is generated in the light bulbs as the electric current glows the carbon thread in the space without air... Edison takes a thin bamboo fibers and chars them up. Such a charcoal thread is then fixed in a small, pear-like container with its ends at platinum wire, welded in glass; and from the vessel he removes air as much as he can ... (At the exhibition) the females were most interested in the use of electric lights for lighting homes..."²⁷³²

In the report of the scientific commission, which Stefan edited more than two years after the end of the exhibition, Obermayer published dubious measurements by which bulbs using an alternating current consumed more energy than those using direct current for the same amount of light. That was a clear Edison's victory just eight years before Tesla temporarily defeated his DC in their war of currents. Because the measurements were not accurate enough, Stefan intended to repeat them, but did not publish the results.²⁷³³

Stefan's and Edison research did not coincide solely with the bulb. The Tasimeter, which Edison invented just before his light bulb, was designed to measure the heat of the stars and the Solar corona.

²⁷³¹ Boncelj, 1960, 48; Stefan, 1883, 269.

²⁷³² Senekovič, 1883, 725-726.

²⁷³³ Boncelj, 1960, 49, 51, 54, 83.

²⁷³⁰ Boncelj, 1960, 33.

It was used to observe the total eclipse of 1878, and the following year they published his description with photographs. At the same time, Stefan published his radiation law and for the first time accurately determined the temperature of the Sun using the measurements of JW Draper, the father of Edison's friend.

22.1.9 Electric Bulb in Slovenia

The first electric bulbs in Slovenia began to be used in high school physics laboratories, since the Slovenians had no domestic universities at that time. Among the curators of cabinet of physics in the territory of present-day Slovenia, Vlahović published the most researches of electrical light. At the Gymnasium in Koper, he studied the duration and shape of the electric spark, consisting of several spatially separated parts.²⁷³⁴

The size of the spacing between the spark parts depends on the properties of the circuit that produces it. He compared his calculations with the simultaneous published experiments of the Italian R. Felici and determined the matching. In 1859 in *Nuovo Cimento* Felici excelled with his direct proof of Wilhelm Eduard Weber's theorem.²⁷³⁵

Vlahović used universal discharger of William Henley who died by his own hand in 1779.²⁷³⁶ Vlahović acquired it in Koper in 1857 under no. 50, but it was not listed among the 54 physics instruments in 1863. Among the 22 electrical and magnetic devices he used in his discussions were: a tube for observation of sparks, a Leyden jar, a Volta's battery and 12 strong Bunsen's batteries. He listed the appliance for the electric light in a vacuum and arc-lamp.²⁷³⁷ Vlahović's charcoal vacuum lamp was first described by Jobard in 1838 in Belgium, and it was successfully sold by Edison only after 1879 (Figure 22-8).

In 1863, the cabinet of physics of the Gymnasium in Koper had 126 florins of annual grants, while the physics cabinet of the Ljubljana gymnasium had received 200 florins by 1858/59, and then 210 florins by the end of the 1860s. It is therefore

understandable that the curator of the cabinet of physics Mitteis had a much greater possibility of purchasing physical devices. Robida had half smaller grants than Mitteis. Robida did not acquire bulbs in his cabinet of physics in Klagenfurt, which he ran between 1847 and 1874. Several bulbs are found in the cabinet of physics of the Gymnasium in Novo mesto, which was led by Franciscan Bernard Vovk (* 1824 Brezovica in parish Ovsiše; † 1911 Brežice) between 1854 and 1884. Table 22-1 lists the lamps recorded in gymnasium reports and in annual inventories in Ljubljana, Koper, Klagenfurt and Novo Mesto. Unfortunately, most of these physical devices are no longer useful today. Many facilities from the Ljubljana gymnasium are waiting for researchers at the Slovenian School Museum, while Vlahović's lamps are still found today in the well-preserved physical room of the Italian Gymnasium in Koper.



Figure 22-8: Vacuum bulbs in the Vlahović (Vlahovich) inventory list at the Grammar School in Koper in 1858/59 no. 103, 1859/60, No.112²⁷³⁸

The census shows how they gradually replaced gas lamps and spirit (alcohol) burners with electric light bulbs in the cabinets of physics of lands inhabited by Slovenes. In 1857, the city council of Ljubljana lent to a gymnasium cabinet of physics a battery with ten elements of Zn-Fe and a regulator for production of electric light.²⁷³⁹ According to

²⁷³⁴ Vlahović, 1863, 4.

²⁷³⁵ Vlahović, 1863, 4.

²⁷³⁶ Vlahović, 1862, 535, 552.

²⁷³⁷ Inventory Koper, no.103, 105 (year 1859), 112 (year 1860); Journal of Grammar school (Izvestja Gimnazije) Koper, 1863, 35–36.

²⁷³⁸ City (Mestni) Archive Koper, Inventario gabinetto di Fisica disposto nell'ordine cronologico degli acquisti.

²⁷³⁹ Journal of Grammar school (Izvestja Gimnazije) Ljubljana, 1857, 28.

Table 22-1: Sources of light according to gymnasium reports in Ljubljana (L), Koper (K) and Novo mesto (N)

Source of light (prices according to Ljubljana inventory from 1866)	Year of purchase (place, inventory number)
gas lamp made of black lacquered metal, product of Freyberger	1809–1845 (L, 357)
Davy's safety lamp (Koper miniature version is preserved)	before 1855 (N, 90), before 1857 (K, 45)
lamp from glass, designed with the siphon	1858 (K, 74)
lamp named after Berzelius	1853 (L), 1855 (N, 47), prior to 1857 (K, 21), 1864 (K, 164)
device with carbon peak for producing electric light	1854 (L, 30)
demonstration device for the glow of galvanic electricity	1856 (L)
Three pairs of peaks made of charcoal	1859 (K, 100)
an electric light source with stings made of charcoal, in vacuum	1859 (K, 103)
Tube for electrical sparks	1859 (K, 105)
an electric light source in vacuum	1860 (K, 112)
induction coil with circular breaker in a vacuum	1860 (K, 114)
arc lamp (in Koper, an electromagnetic regulator of the electric arc is preserved)	prior to 1863 (K)
spirit lamp in glass (63 kr)	prior to 1866 (L, 22)
devices used to produce the electric light with a driving force (gear) and a reflector	1868 (L)

the inventory list on August 15, 1876, two kerosene lamps were suspended under the ceiling at the Gymnasium in Koper. In 1886, two electric lamps were purchased for the Koper Cabinet of physics and the authorities announced that "others will be installed". Unfortunately, the manufacturer of these lamps was not listed. At the time of Inwinkl's term as curator, in 1908, the physics cabinet of the Gymnasium in Koper was equipped with an independent electrical installation which gave a voltage of 1 to 250 V and a current of 0.1 to 30 A.²⁷⁴⁰

Thus, the educated Slovenians already knew the characteristics of electric bulbs when these started to come into public use. Outside high school laboratories electricity was used for lighting for the first time in Slovenia in 1880. In April 1883, they lighted up the mill of Karl Scherbaum (1818-1901) in Maribor. The next year, twelve electric arc lightings in the Postojna Cave lit up, while the first public power plant with in Slovenian areas started operating in Škofja Loka. In 1894, the cloth manufacturer Alojzij Krenner (1841 Škofja Loka-1895 Škofja Loka) offered part of his generated

electricity of the steam power plant to the purchase to the municipality for the needs of public lighting Škofja Loka. The municipality paid 360 gold denarius a year to Krenner, and under a contract signed on May 8, 1894, he pledged to illuminate the streets of the city for 30 years "every day from the beginning of the darkness to two after midnight and from quarter to six in the morning to a white day with 40 electric bulbs of 16 normal candles" by the Siemens & Halske's system.

Similarly, two years previously, Trbovlje coal mine company installed a steam generator at the engine room of the mine in Kočevje, which, beside the current for its own lighting, also supplied electricity to the city for electric arc lightings of several streets. During the construction of the water supply, the Kočevje natives found that water pumping machines could produce electricity. That is why they supplemented the plans of the regional engineer professor at the Czech Polytechnic in Prague J. V. Jan Vladimír Hráský (Hrasky, 1857–1939 Prague). On 10 October 1896, they obtained a building permit for the construction of a 45-horsepower plant. From 20 March 1896, the little-known building company Carl Greinitz Neffen from Graz built a machine room, an electric power station, a plumbing plant and an administrative

²⁷⁴⁰ Journal of Grammar school (Izvestja Gimnazije) in Koper, 1886, 1908.

building for 176 days. The electrical equipment for the engine room was supplied by the Franz Pichler's factory from Weiz, and the well-known Brno enterprise Brand & Lhuillier delivered boilers and two steam engines connected with piston pumps for pumping water. Thus, the steam engines simultaneously propelled both the water pump and the two dynamo machines. They produced a direct current with a voltage of 2×150 V, which was very high for those times. A smaller dynamo was installed for the reserve, and a switchboard and a balancing accumulator battery with 200 elements and a capacity of 56-80 Ah.

On 19. 11. 1896, in Kočevje, 4 km of electric lighting lines were opened with 700 light bulbs of 16 candles and power lines with a cross-sections of 8 mm^2 . Thus, Kočevje became the first fully electrified city in Slovenian lands.

Since 1889, the Commission of Ljubljana for the Study of the Hydroelectric Power Plant has been studying possibilities for the construction of a hydroelectric power plant or a thermoelectric power plant. Although the commission advocated an alternating current thermal power station, the City Council, following a proposal by a Viennese expert, decided to take a DC. Edison therefore prevailed over Tesla. In 1897, the thermal power plant was located at an inappropriate place in Fužine near Ljubljana, as there was no running water or a railway in the vicinity. The thermal power plant had two steam engines of 200 KM and two dynamos of 140 kW for 300 V. From the plant, a cable was transported to the main road, where the power supply was supplied from the storage station between 24 P.M. and 5 in the morning, when the power plant stopped, until the for full-day operation was needed due to the tram after 1901.

On 1. 1. 1898, half a year after the earthquake, Ljubljana got new thermoelectricity power plant on Slomškova street number 18 with two steam engines of the firm Erste Brüner Maschinenfabrik and DC dynamo of Siemens & Halske. Suddenly, the first 794 light bulbs and 48 electric arc lightings blazed on the streets of Ljubljana. 149 users had 6358 bulbs, 89 arc lighters, 12 engines and 3 appliances with a total of 290 kWh. Until 1905, electric light bulbs in Ljubljana prevailed over the older gas lighting, which remained in some areas with Auer's "bulbs" until 1946.

22.1.10 *The Bulbs in the Works of Stefan's Contemporaries and Students*

With Edison's success, the research of a bulb in the USA has outperformed development in Europe. Nevertheless, an interesting view of the European achievements and the merits of Slovenian Stefan is offered. Stefan's research path surprisingly interwoven with the discovery of the dozen years younger inventor Edison. Stefan's colleagues and students soon described the Edison lamp in the Slovene language, the first among them Stefan's antagonist Simon Šubic of Graz university: "Edison's electric lamp is like a hollow pear of glass, which is attached by the tail to electric ties. From its inside the air is extracted as much as possible. In its cavity deprived of air it had a thin vault of bamboo charcoal, which is elastic and hard as steel, so that it doesn't burn down while crossed by the strong electric currents. It just warms up and heats without burning so long as it has no air in its interior space. However, since the space cannot be emptied completely, and because it cannot be clogged so well that over a time there will be no air in it, it will burn some of this charcoal with time at the remaining air so that this light bulb does not shine further than some eight hundred to thousand hours.

Then, on the average each half a year, the old lamp should be replaced with a new one ... Before Edison and Swan came up with their handy electrical lamps, and before Siemens introduced its differential lamp, the people had great hope for Jabločkov's candle for some time, but it was impossible to eliminate its unpleasant characteristic. Jabločkov's electric candle consists of two carbon standing nails; the space between the nails is filled with plaster: at the upper end it is covered by a thin graphite plate. When the current of electricity flows through charcoal nails, it goes also through the graphite plate which is heated to light and shine. With time, the ends and even the whole candle are burned down. The greatest obstacle to everyday use is that all electrical candles, which are drawn into that electrical bond, are extinguished if only one or those candles goes out to begin with."²⁷⁴¹

²⁷⁴¹ Šubic, 1882, 483, 484–485.

Table 22-2: Electric bulbs in the 19th century.

Year	Inventor	Country of origin	Burning element	Environment
1838	Jobard	Belgium	charcoal	vacuum
1840	Grove	Wels, England	platinum	air
1841	F. de Moleyns	England	charcoal	vacuum
1844- 1845	Starr, Sanders, King	USA	platinum, charcoal	air, vacuum
1847	J. W. Draper	USA	platinum in glass	spectrum with prism ²⁷⁴²
1848	Staite	England	platinum/iridium	Air
1849	Petrie	England	Charcoal	vacuum
1850, 1852, 1858	English patent agent Edward C. Shepard on behalf of grandnephew of Jean-Antoine Nollet the Brussels professor Floris Nollet	England, France	Charcoal	vacuum
1852	Martyn John Roberts (1806–1878)	England	Charcoal	vacuum
1854	Acquired in Ljubljana	Habsburg Monarchy	Charcoal	vacuum
1856	De Changy	France	platinum, charcoal	air, vacuum
1856	Acquired in Ljubljana	Habsburg Monarchy		
1858	Samuel Gardiner the younger (1816-1880 Syracuse New York) and Levi Blossom	USA	platinum	vacuum
1858	Heinrich Goebel	German, USA	platinum	vacuum with mercury vapours
1859	Acquired in Koper	Habsburg Monarchy	charcoal	Vacuum
1859	Moses G. Farmer	ZDA	platinum	Air
1860	Swan	England	platinum, charcoal	Vacuum
1860	Acquired in Koper	Habsburg Monarchy		Vacuum
1865	Dr. Isaac Adams	USA	charcoal	Vacuum
1865	Bought in Ljubljana	Habsburg Monarchy		Vacuum
1872	Aleksandr N. Lodigin	Russia	Charcoal	vacuum, nitrogen
1873	Конн (Станислав Викентьевич Кон)	Russia	Charcoal	Vacuum
1875	Kosloff (Степан Александрович Козлов)	Russia	Charcoal	Nitrogen
1876	Bouliguine (Николай Павлович Булыгин)	Russin	Charcoal	vacuum
1878	Fontaine	French	Charcoal	vacuum
1878	Lane-Fox	England	platinum-iridium / asbestos-charcoal	nitrogen, air / nitrogen
1878	William E. Sawyer, Albon Man	USA	Charcoal	Nitrogen
1878	Hiram Maxim	USA	Charcoal	Hydrocarbon
1878	Farmer	USA	Charcoal	Nitrogen, vacuum
1878	Edison	USA	Platinum	air, vacuum
1878	W. Siemens	Germany	Metals	Air
1879	Swan	England	Charcoal	Vacuum
1879	Edison	USA	Charcoal	Vacuum
1880	electric lighting in Tržič			
1883– 1885	Stefan measures the capacity of the light bulbs	Slovenian in Vienna	Different	

²⁷⁴² Bowers, 1998, 71.

Henrich Schreiner learned physics at Maribor's Gymnasium by Anton Šantel and studied natural history, mathematics and physics in the class of J. Stefan in Vienna in 1877. He was a professor and director at the gymnasium in Gorizia between 1884-1891. The professor of Physics and Deputy Director in Bolzano Henrich Schreiner (* 1850 Ljutomer; † 1920 Maribor) described Edison's lamp ten years after the discovery: "A platinum wire was burning, if a galvanic electrical current through it is extends, if it is sufficiently thin and the current is strong enough. It produced so much light that it can be used for a glowing electric light. However, the experience teaches that heat and the light of the wire, which is glowing in the direction of the overflowing current, grows stronger as the translation of electricity gets worse. More often they do not use platinum wires for a glowing electric light, but some other substance that poorly translate electricity. Above all, it is required that a substance that readily produces an electric light does not dissolve prematurely in high heat. After numerous attempts, they found that the most fitting body for a glowing electric light is a thin filament of charcoal. We produce those threads by charring thin vegetable fibers or human hair. This method of carbon sequestration was invented by the American Edison. As a result, the lamps which use a glowing electric light are called Edison's incandescent bulbs."²⁷⁴³ Certainly, any involvement of female hair was never Tesla's favourite.

Chief of the Ljubljana Waterworks and Power Plant Stefan's student between 1875 and 1881 Ivan Šubic, described Edison's lamp in the first Slovene book dedicated to electrical engineering: "We want to describe now the light bulb produced by the modern factories. As we already know, each bulb consists of a glassy, airless balloon in which the charcoal burns. The electrical current is introduced through the glass balloon to the carbon seal using two platinum wires that are immersed in glass. The light bulb therefore has three main parts: glowing carbon, conducting wire and the balloon or pear..."²⁷⁴⁴

In Table 22-2 we have an overview of the development of the electric bulb and its echoes in Slovenian areas.

²⁷⁴³ Schreiner, 1889, 177.

²⁷⁴⁴ Šubic, 1897, 130.

Pavel Nikolaevich Jablockov from Serdobsk in Saratov gubernia (Сердобск, Саратовской губернии) graduated from Nikolaev Engineering School (Николаевская инженерная академия) in 1866 and, three years later, from the Technical galvanic Institute of Petrograd (Техническое гальваническое заведение в Кронштадте). As a telegraph engineer, he headed the installation between Moscow and Kursk. In 1875, he resigned his job and went to the United States to attend the exhibition in Philadelphia next year. But he only came to Paris, where he worked with Bréguet, who developed telegraphy and electric watches for the French Navy and the railways. At that time, Paris was the center of the development of electricity, as the Belgian Gramme designed the first useful generator in 1870, which was used primarily for lighting. In 1876, Jablockov created the "electric candle" named after him as the first useful electric lamp. As the first one he used an AC power capacitor and made new versions of transformers, batteries and other electrical devices.²⁷⁴⁵

22.1.11 *The Arrival & Future of the Light: Lifestyle of the Bulb*

Edison's work created the legend. On October 21, 1929, the former Edison worker Ford invited Edison to repeat his experiment with a bulb in the renovated Menlo Park upon its fiftieth anniversary. Despite the replacement of the charcoal element with tungsten and a whole series of small improvements, the bulb is, besides the cathode ray tube, one of the most distinctive unchanged elements in electrical engineering. In the 21st century, however, the question is whether the cathode-ray tube with a luminous fluorescent coatings could force the bulbs out of the market, while liquid crystals screens of televisions and PC work without a cathode-ray tube.

22.2 Stefan's Kinship

J. Stefan certainly played one of the leading roles in introductions of incandescent light bulbs and much more. Stefan's unmarried mother was of poor humble origin and Stefan finished his High School in Klagenfurt being more often worried

²⁷⁴⁵ Bowers, 1998, 65.

than happy. The top physicist Karel Robida used to be high school professor and form master of Jožef Stefan. Robida was born at the Ljubljana suburb and taught at Klagenfurt. He had hard awful times before he got the necessary education required for the professor of physics at Klagenfurt. He was proud of his Slovene origin and passed the same feelings to his students. Just after the March revolution he published the very first Slovenian textbook of physics. He hoped to make an official textbook out of it, but the politics suddenly changed, and he failed because physics was not taught in Slovenian language at secondary schools anywhere. Despite of that Robida's Slovenian physics was widely read even among the Slovenian peasants. Robida's scientific works are worth of serious study. His research began with the original theory of electricity and magnetism. In practically no time Stefan's senior collaborator Grailich published considerably sharp critique of Robida's claims. Just five years after the discovery in England, Robida published his experiments with cathode sputtering, one of the main tools of modern vacuum nanotechnology. Robida's atomic theory was innovative, but never had much of a real influence. Subsequently broader audience read Robida's quarrels with Krönig and Clausius about the fundamentals of the new kinetic theory. Robida had some useful objections, but he was a little bit old fashioned and his criticism tried to stop new development of statistical dynamics that soon proved to be very successful. Therefore, despite of the good physics involved, Robida's line of thought had no future for the time being. Robida also discussed the early version of reversibility paradox. His mathematical treatment of atmosphere was very useful and could be compared with the achievements of Laplace and other researchers. Robida's physics was among the best of his time in Habsburg monarchy, and we hope that the neglect of his achievements was just contemporary. Robida should get the due recognition for his great scientific and pedagogic work for the 150th anniversary of his death on October 4, 2027.

Robida's very best students were the famous physicists J. Stefan and Peter Salcher. Stefan did not particularly like somewhat old fashioned Robida's theories, but he certainly learned a lot in Robida's classroom.

Robida was also interested in the history of physics and wrote a useful article about it as Stefan's class teacher. Robida's work was very popular among his contemporary high school students. Robida taught physics and mathematics in Klagenfurt for twenty-seven years and published several articles about atoms which were widely discussed all around Europe. He focused mathematical lecturing and early Stefan's works followed his path. A very good form master Robida's lectures during Stefan's final high school classes paved Stefan's path to fame.

The life and years of study of Slovene teacher Robida enabled his physical papers, the first book about physics in Slovene language and many mathematical, theological, scientific and practical works, mostly in Slovene language. Robida's mathematical pedagogical work influenced the similar Stefan's early publications.

Robida was the author of first book about physics in Slovene language, Stefan's teacher, and forerunner of the reversibility paradox. As most geniuses like Gauss, Stefan soon refused to respect Robida's merit. The physics and its political society's environment went through rapid changes with the spring of nations of 1848. The generation gap between Robida and Stefan proved to be too deep for the mutual understandings of their concepts in physics.

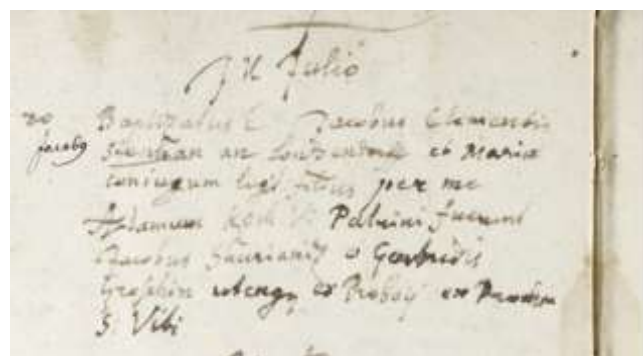

Figure 22-9: Clemens Stephan and his wife Maria as the paternal grandparents of J. Stefan's grandfather Joannes Stephan noted upon the baptism of their son Jacobus in 1687 (Baptism book of Carinthia St. Lancova-Lanzendorf in Škočjan pri Podjuni (Sankt Kanzian am Klopeiner See in Jauntal) page 34v. Godparents were Jacobus Škrjanc (Shurianiz) and Gertrudis Graschin et cogn (and her husband) ex Proboij ex parochia St. Viti (Proboj of parish St. Veit im Jauntal/Št. Vid in Podjuna).

The history of the research of radiation in the Physical institute of Vienna during Stefan's time made its great echo in works of other contemporaries. For the first time in the historiography our relation is established between Stefan radiation law and the simultaneous Edison's and other researches of vacuum incandescent lamp displayed on Stefan's electrotechnical Viennese exhibition in 1883. Few weeks later, Boltzmann's verification of Stefan's law followed Boltzmann's critique of Bartoli's opinion about the radiation in radiometer in vacuum. Therefore, direct connections of Stefan's law and vacuum research of his time is obvious. Stefan was a real godfather of his student Boltzmann even if it meant criticizing Stefan's compatriot Simon Šubic. Quarrels among physicists Stefan, Šubic, and Robida show that the cosmopolite enemy of travels Stefan preferred to promote the supporters of his kinetic statistic atomic ideas over his fellow Slovenian national feeling although Boltzmann's half Slovenian bride might carry some weight anyway.

The vacuum related research at the Institute of Physics of Jožef Stefan was great, probably it filled the early vacuum emptiness absence of Stefan's illegitimate father. The newly discovered archival material about professional and private life of Jožef Stefan and his relatives is used to prove the idea of DNA relations of the successes of talented guys on the ruins of the evil-destinies of his or her less fortunate relatives.

22.2.1 Introduction

Stefan-Boltzmann's story of success in physics ended in suicide. Their archenemy Mach earned fame despite of his son's suicide and Mach's posthumous success in philosophy made his positivism fashionable. We'll try to find out who was the real winner between their antagonist groups. If there ever was any possibility to win such an eternal fight at all between the invisible ultimately small particles and their positivistic criticism.

On the 10th and 18th of December 1879, Jožef Stefan published his famous radiation law for the first time for the Viennese Academy. It is still the single important physical law named after the Slovenian guy. Five years later, Boltzmann

confirmed Stefan's law with criticism of Bartoli's radiation analysis in a vacuum radiometer. Therefore, it is right to mark those important innovations with some recent discoveries about the connections of Stefan's radiation studies with the then vacuum surveys at the physics which prepared itself for funny quantum jumps.²⁷⁴⁶

²⁷⁴⁶ Many guys wrote about Stefan. Albert von Obermayer, Boltzmann and Eduard Suess' 1893: *Josef Stefan* had reminiscence aspects as Stefan's colleagues. Their follower was G. Jäger with his *Vortrag über Stefan in dessen Geburtsort...*, 1935. The Slovenian local Stefan's fans were Ivan Šubic, Lavo Čermelj, Janez Strnad, Sandi Sitar, and Josef Boncelj's 1958: *Jožef Stefan und seine Tätigkeit auf dem Gebiet der Elektrotechnik*. In: Sonderdruck der Zeitschrift „*Elektrotechnik und Maschinenbau*“, 75th year, volume 24, pp. 666-674. Južnič added 2002. Fizik Karel Robida (1804-1877), pisec prve slovenske knjige o fiziki in učitelj Jožefa Stefana. *Zbornik za zgodovino znanosti in tehnike*, Ljubljana, SM. 15-16: 112-161, 2004. Raziskovanje vakuuma na (dunajskem) fizikalnem inštitutu Jožefa Stefana. *Vakuumist*. 24/4: 24-32, 2007. Dr. Karel Robida (1804-1877), gimnazijski profesor in razrednik Jožefa Stefana (Ob 130letnici smrti). *Šolska kronika*. 16(40)/1: 7-15 and Jožef Stefan v Slovenski fiziki s posebnim ozirom na belokranjske znanstvenike. 5. *Zborovanje Društva učiteljev zgodovine Slovenije, Črnomelj*. The stories about Stefan's best student and his fiancé are on 2001. Ludwig Boltzmann in prva študentka fizike in matematike slovenskega rodu. *Kvarkadabra*. Internetni časopis. Ljubljana; The narratives about Stefan's archenemy Ernst Mach followed on: 6. 3. 2016. Uresničene nadzvočne sanje izpod Gorjancev. Ob stoletnici smrti Ernsta Macha: dolga pot do ugotovitve, da sta za neznosne rane na bojišču krivi hitrost in oblika izstrelka. *Delo Znanje*; April 2016. Prvi fotograf nadzvočnih izstrelkov. Ob 100. obletnici smrti Ernsta Macha in poldrugem stoletju torpedov. *Življenje in tehnika*. April 6: 42-51, 2016; Ob 100-letnici smrti Ernsta Macha, ob 150-letnici izuma torpeda. Pionirski posnetki nadzvočnih bojnih izstrelkov sina graščaka spod Gorjancev (ob stoletnici smrti Ernsta Macha, ob sto-petdesetletnici izuma torpeda). *Revija Obramba*. March 2016. 3: 51-55; 11th May 2016 Prva fotografiranja nadzvočnih izstrelkov sina graščaka spod Gorjancev za snemanje sodobnih plazemskih turbulenc v magnetronu (ob stoletnici smrti Ernsta Macha) *Vakuumist* 36/1: 19-26, 20. 5. 2016 Učitelji Salchera i Macha (U povodu stogodišnjice Machove smrti) Salcher & Mach's teachers (On centennial of Mach's death) pages 50-51. VII Međunarodna konferencija o industrijskoj baštini posvećena temi; Torpedo – povijest i baština; 150. godišnjica izuma Luppis-Whiteheadova torpeda; 7th international conference on industrial heritage Torpedo – history and heritage; 150th Anniversary of the invention of the “Luppis-Whitehead” torpedo; Rijeka, 19. – 21. svibnja 2016. / *Rijeka, 19th – 21th May, 2016*; May 2016 Pionirski posnetki nadzvočnih bojnih izstrelkov sina graščaka spod Gorjancev (ob stoletnici smrti Ernsta Macha). *Slatenska dolina in Machova dediščina pod Gorjanci*. Marjan Hren. Novo mesto: Založba Snovanja Društva Upokojenec. 106-113; July 2016, Ernstove nadzvočne sanje izpod Gorjancev so se uresničile. (ob stoletnici smrti Ernsta Macha). *Rast* (Novo mesto), 27/1: 65-69. There was more on Stefan's student Benigar's pupil

It seems that J. Stefan is on his victorious way to the recognition of his merits worldwide, a little late but from the bottom of many hearts. J. Stefan was a mastermind behind the victories of kinetic atomism and statistical mechanics although he as the devoted Catholic was unable to fight Mach's opposition in philosophical grounds like Boltzmann did, and Stefan indeed died prematurely to put his name on quantum mechanics' flags.

Mileva Einstein: Einsteinov prispevek k razvoju naravoslovne filozofije. *Tribuna. Studentski časopis*. 12. 3. 1979. Letnik 1978/79, volume 28, number 10-11, page 8-9 and September 2004. Answer to Planck – Written in Mileva Einstein's Handwriting. In: Krstić, Djordj. *Mileva & Albert Einstein Their Love and Scientific Collaboration*. Radovljica: Didakta. 236-246. Translation: 2005. *Odgovor Plancku*. Novi Sad: Srbska Matica. Stefan's relative the great grandson of Stefan's first cousin, Karl Josef Westritsch, added Carinthia-based view in 21st century including: 2012. Jožef Stefan - Eine biografische Spurensuche zum 120. Todestag: Zur Erinnerung an den Physiker und Menschen aus Kärnten. Grin Verlag and 2015. 180. Geburtstag von Jožef Stefan: Physiker, Lehrer, Mensch. Grin Verlag and 2015. Jožef Stefan: Karnten Ein Einerlei Volk. Grin Verlag and Jožef Stefan 1835-1893: Karntner Physikpionier - Lehrer – Mensch. 2016, Disserta Verlag. Other Carinthia locals include: Weiß, Ida 1976: Der große Gelehrte aus der Franzleusche. Zum Gedenken an Jožef Stefan, den aus Kärnten stammenden Begründer der österreichischen Physiker-Schule und Lehrer von Ludwig Boltzmann. In: *Die Kärntner Landsmannschaft*, Heft 4 while the relative of J. Stefan's Ferlach family branch of Ogriz, Alfred Ogris published in 1982: Jožef Stefan- ein berühmter Physiker aus Kärnten. In: *Kärntner Landesarchiv, Die Kärntner Landsmannschaft*, Heft 10. Klagenfurt; Adamcik-Preusser zu Niederberg H. *Die wissenschaftliche Bedeutung der physikalischen Arbeiten von Jožef Stefan*. Dissertation. University of Vienna 2004 added Habsburg view as did: Bittner, Lotte 1949: Geschichte des Studienfaches der Physik an der Universität Wien, pp. 321-323. Other modern Austrians added their ideas published as: Wagner, Kurt 1991: *Jožef Stefan ein österreichischer Physiker*, pp. 305-318; Spitzer, Sebastian 2011: *Jožef Stefan 1835-1893. Ein Mensch in der Lebensluft zweier Sprachen*. In: Festschrift 150 Jahre HTL1 Klagenfurt, pp. 96-99; Ottowitz, Niko from Slovenian Grammar School of Klagenfurt: 2011: *Jožef Stefan. Streiflichter aus seinem Leben und Werk – zum 175. Geburtstag*. Klagenfurt; Edward L. Cussler of Minnesota University added American view in Lightfoot, E.N., Edward L. Cussler and R.L. Rettig, Applicability of the Stefan-Maxwell Equations to Multicomponent Diffusion in Liquids, *AICHE Journal* 8, 708 (1962). John C. Crepeau of Department of Mechanical Engineering of University of Idaho in a city with a funny name like Putin's Moscow surpassed Cussler by many discussions of Stefan's thermal research including: *Jožef Stefan: His Scientific Legacy on the 175th Anniversary*, March 2013, Sharjah: Bentham Science Publishers.

22.2.2 Genial Stefan as the Illegitimate Kid

The talent is not enough. You need to give yourself a wind, and J. Stefan's illegitimate birth was a kind of tornado for his ambitions. If he was deprivileged by birth in all aspects, why not pose as cleverer than his classmates? The folks in Geiger's farmhouse loved the smart polite kid J. Stefan, but the opinion of all-prevailing church was decisive: he was a product of forbidden sin, whatever it might be. Period. Full stop. The kid J. Stefan was freak although he did not know that while it was not his fault at all. D'Alembert, B. Hacquet or Riccardo Felici's fathers were also not married to their mothers, but they at least claimed a great (noble) paternal descent which poor Jožef (Josef) was denied. The illegitimate descent was also far more focused by the other kids' ridicule in agricultural Klagenfurt suburb of Josef than in much more cosmopolite Paris or Parma. During the Vormarch Habsburg monarchy the illegitimate descent was even much more stigmatic than being a recent Jewish convert and stimulated the talents of illegitimates, if they had some abilities to spare.

Bericht des General-Secretärs. 257

Wunsch, einen eigenen Herd zu besitzen. Im Jahre 1891 verehelichte er sich zu Friesach in Kärnten mit Frau Marie Neumann, Witwe des Staatsbahn-Inspectors Adolf Neumann, und diese Ehe ist ihm eine Quelle späten und kurzen, aber, wie aus der Veränderung seines ganzen Wesens sich ergab, überaus tiefen und innigen Familienglückes geworden. Seine Kindheit war so kalt und leer gewesen, dass er, wie er selbst gestand, niemals einen Christbaum gesehen hatte, ausser durch fremde Fensterscheiben hindurch. Im December des vergangenen Jahres war er von dem Gedanken beschäftigt, den Ehenkel seiner Frau einen grossen Christbaum zu schaffen. Das war ihm neu und machte den berühmten Physiker glücklich. Noch am 15. December v. J. überreichte Stefan der Akademie eine Abhandlung „über das Gleichgewicht der Elektrizität auf einer Scheibe und einem Ellipsoide“. Am dritten Tage darauf, am 18. December, bei dem Besuche eines Freundes, wurde er in fremdem Hause von einem Schlaganfalle niedergestreckt. Die ersehnten Weihnachtsbrachte er in Bewusstlosigkeit zu und am 7. Januar entschlief er für immer.

Unser wirkliches Mitglied Dr. Anton Winckler wurde am 3. August 1821 zu Riegel bei Freiburg im Breisgau geboren; sein Vater war der dortige Adlerwirth. Unter beengten Verhältnissen absolvirte der junge Winckler seine Studien; er legte 1844 mit Auszeichnung die Staatsprüfung als Ingenieur in Karlsruhe ab und wendete sich von da an zuerst dem Studium der Astronomie, dann der reinen Mathematik zu. Seine Lehrer waren Nikolai in Mannheim, dann Dirichlet und Eocke in Berlin. Im Jahre 1847 erhielt er eine Stelle als supplirender Lehrer an der polytechnischen Schule in Karlsruhe; 1851 erschien seine erste Schrift: „Nouvelle démonstration d'un théorème de Legendre“ in Liouville's

Almanach. 1893. 17

Figure 22-10: Eduard Suess' 1893 note on page 257: the mother of all later errors of the place of Stefan's marriage while even the date might be 1892 (Eduard Suess, 1893. Almanach. 43: 252-257).

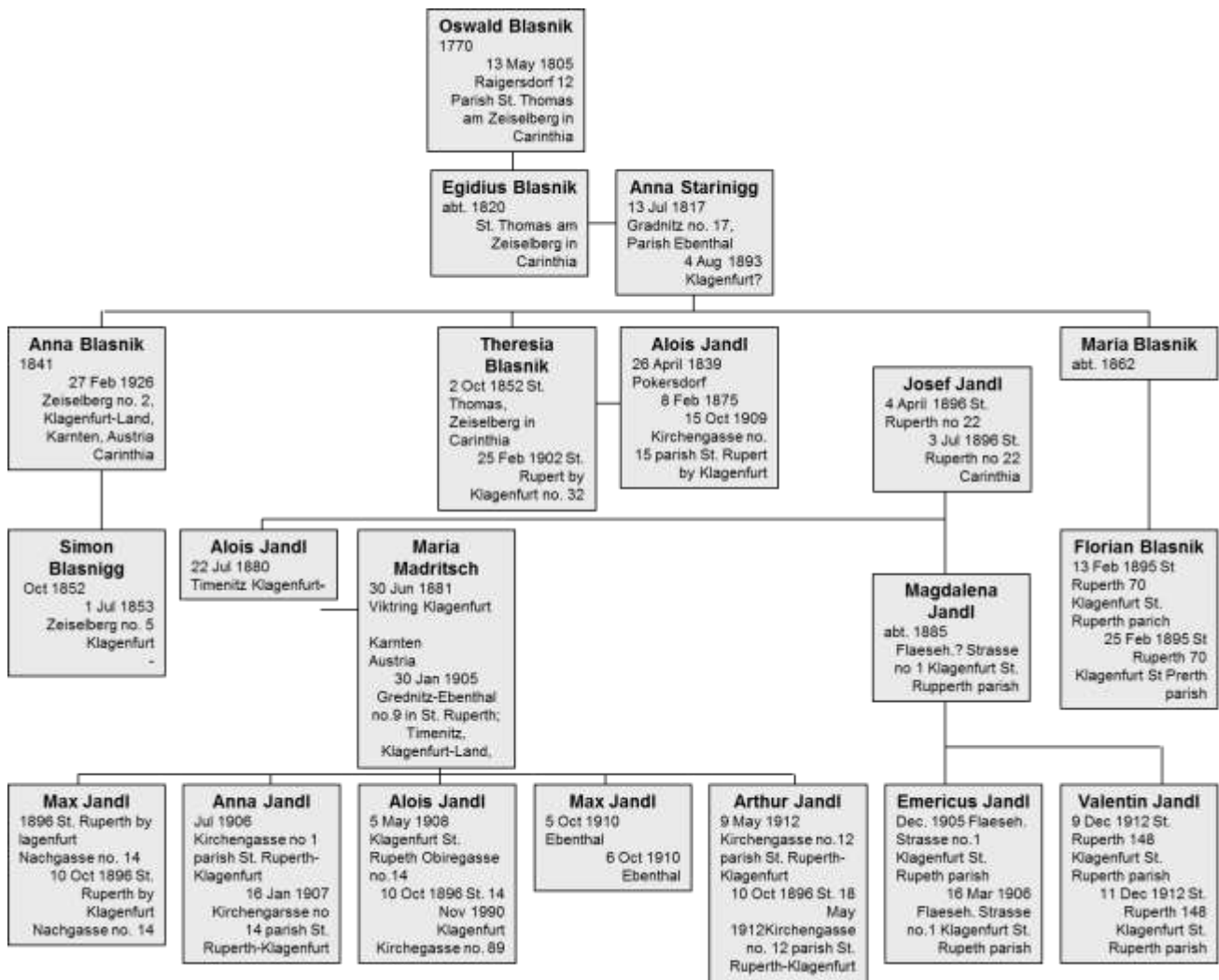

Figure 22-11: Stefan's ancestors on Blasnik's and his heirs Jandl's branch

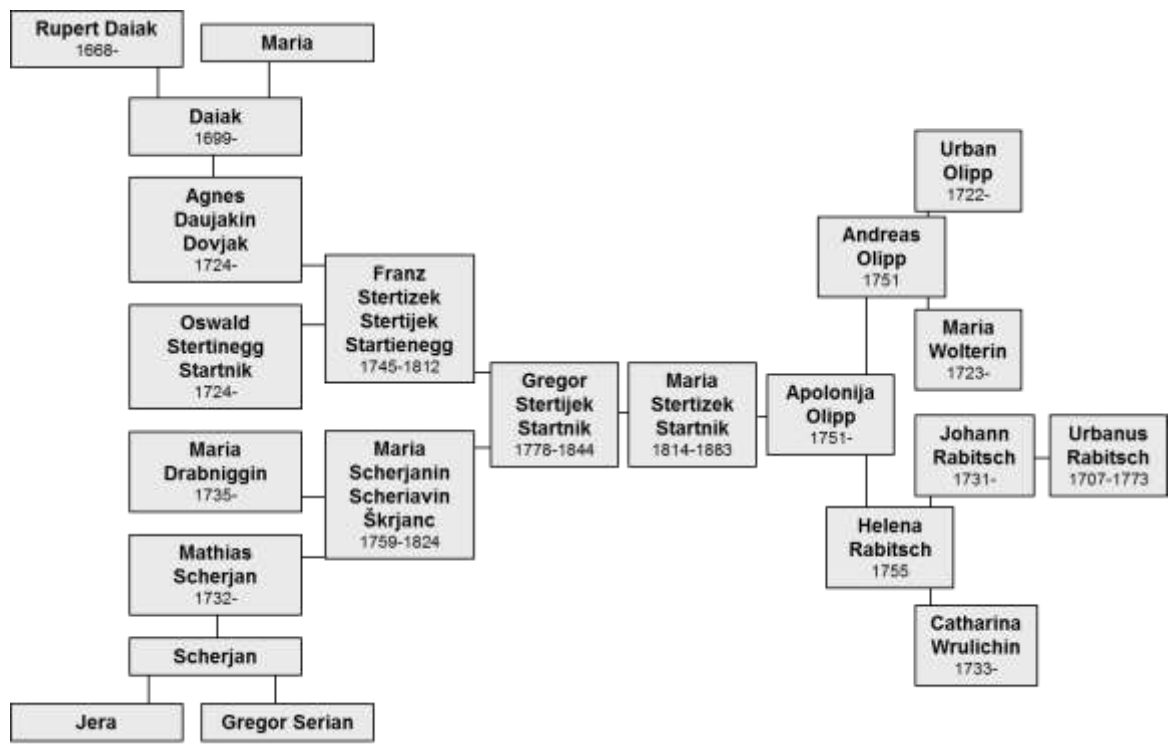

Figure 22-12: Stefan's ancestors on his Startnik's branch.

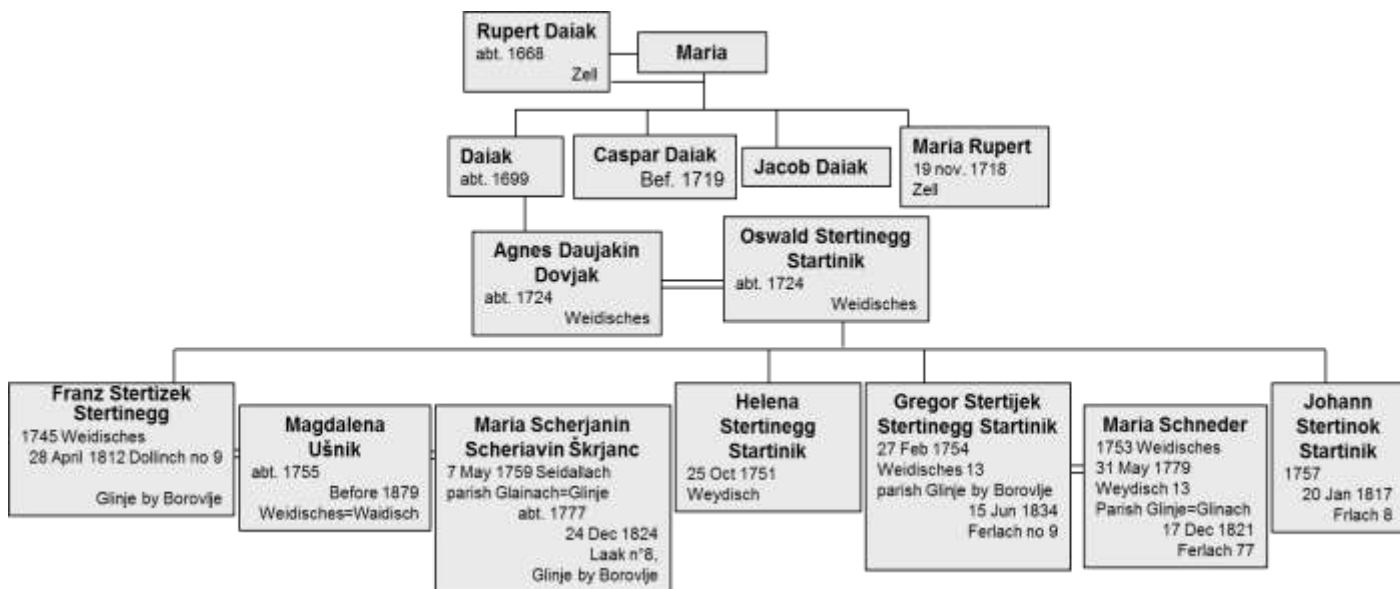

Figure 22-13: Stefan's ancestors on Daiak's (Dejak) branch

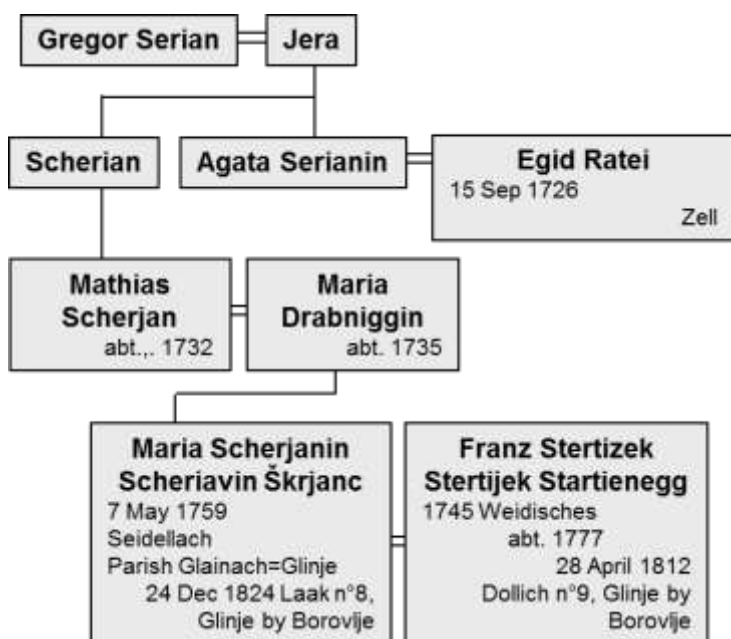

Figure 22-14: Stefan's ancestors on Serian's (Škrjanc) branch

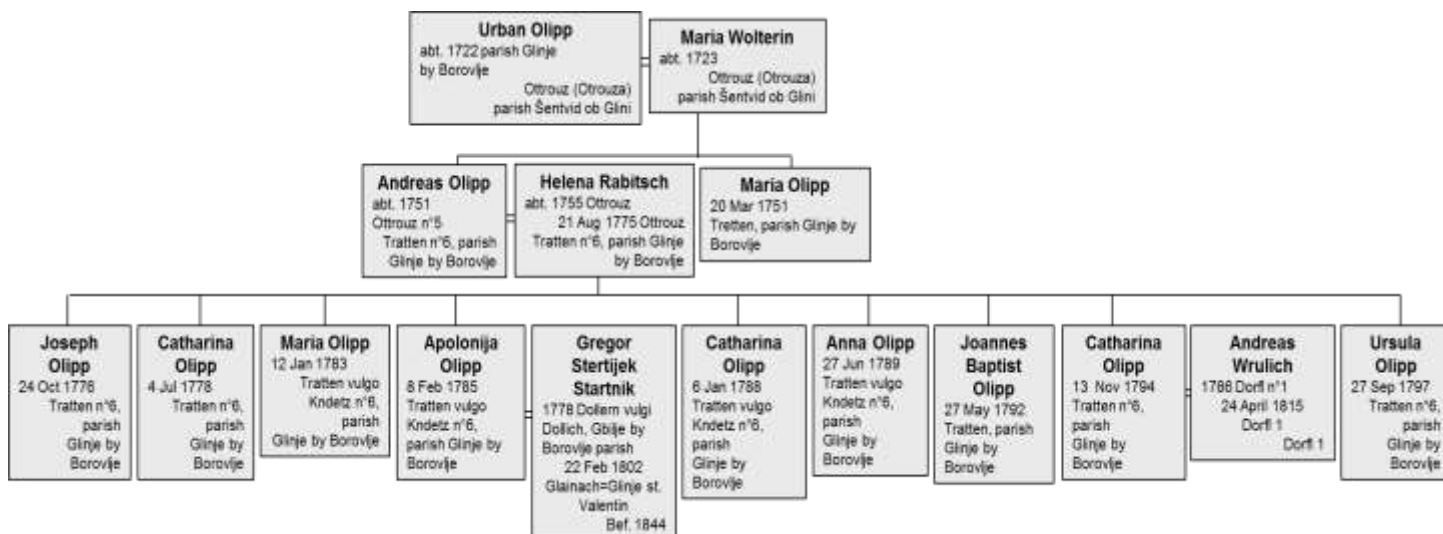

Figure 22-15: Stefan's ancestors on Olipp's branch

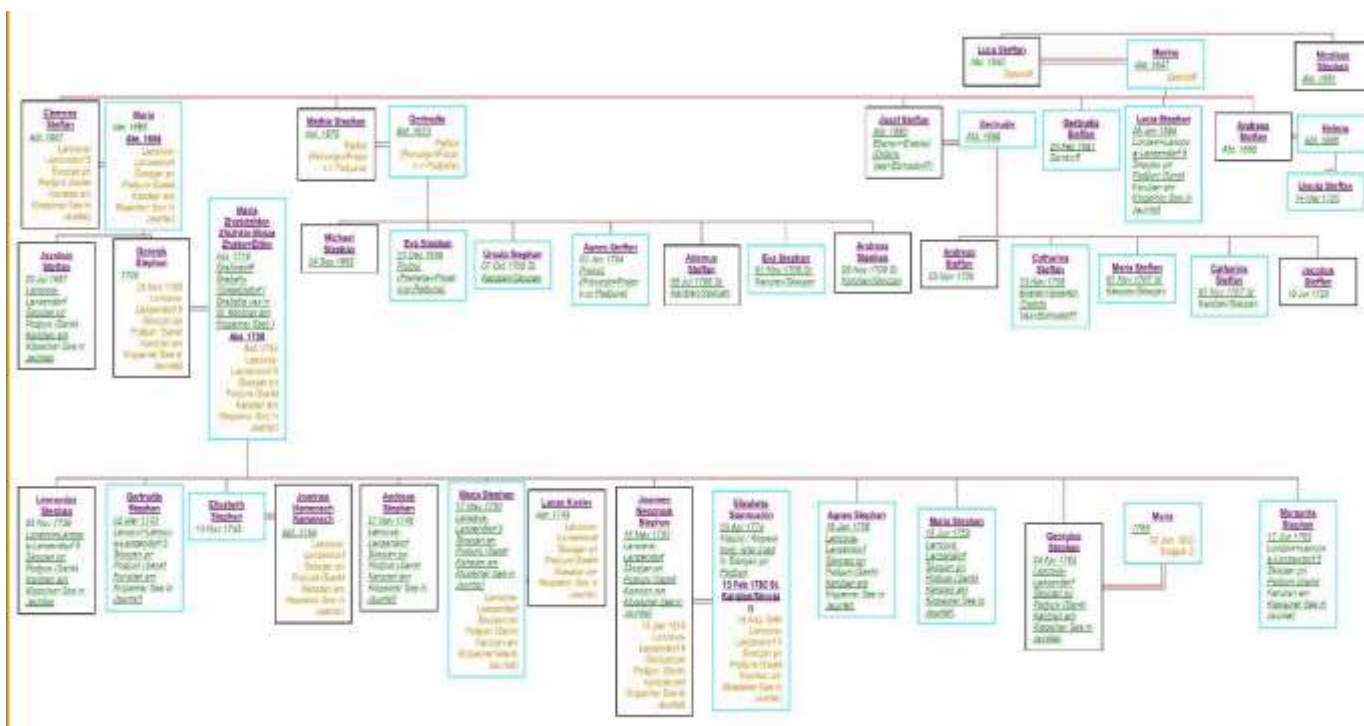

Figure 22-16: Stefan’s ancestors on his father’s branch

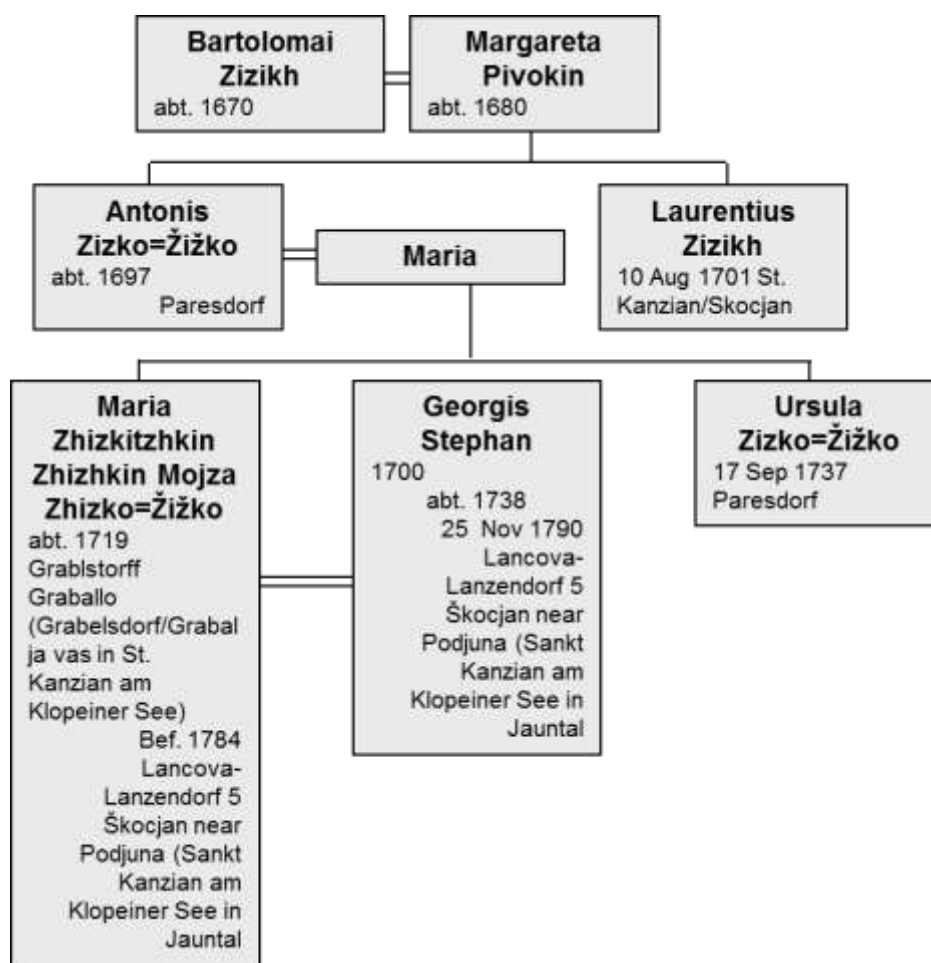

Figure 22-17: Stefan’s ancestors on Zizikh’s (Žižek) branch, just like the philosopher Slavoj Žižek

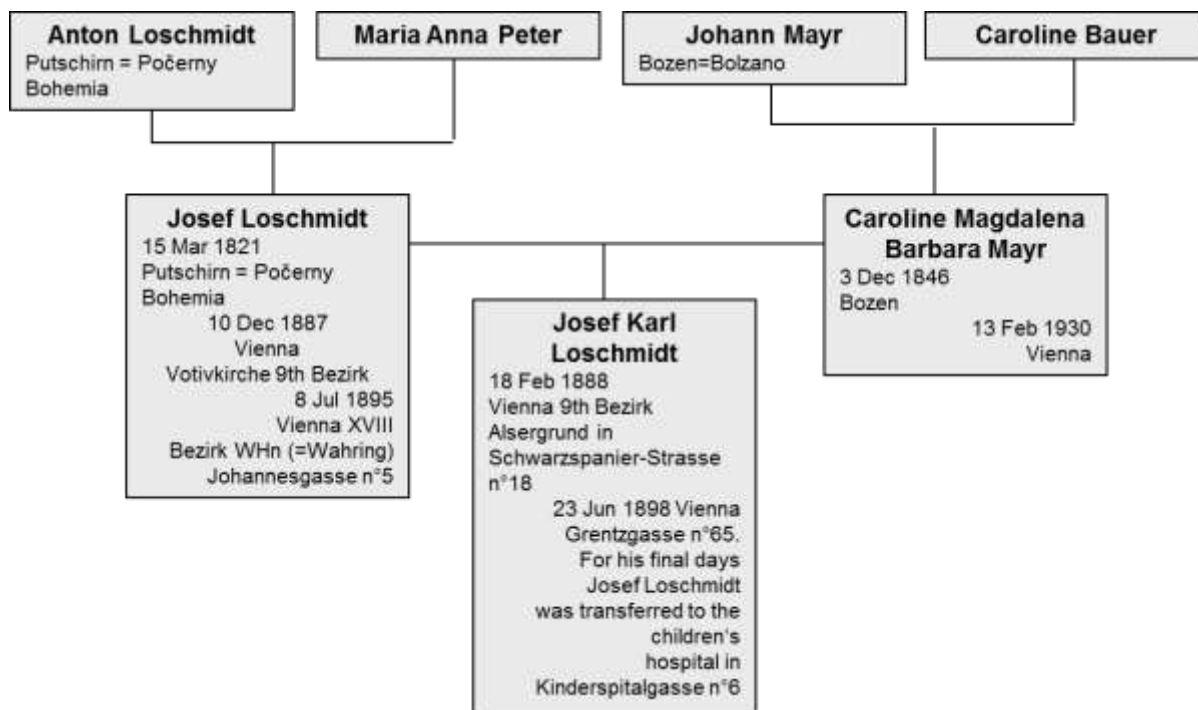

Figure 22-18: Loschmidt's family tree.

For many centuries Stefan's ancestors on his father's branch had managed a prosperous farm in Lancova no. 5 in the parish of Škocjan in Podjuna (Stefanhube in Lanzendorf Haus Nr. 5, St. Kazian, Sankt Kanzian am Klopeiner See, That is a part of a region of Velikovec (*Bezirk Völkermarkt*) where the Slovenian Carinthia native Gregor Slugovc-Sternad in ranch Gorničar) still run a family inherited farm with 24 ha of woods, 60 ha of farming soil, 25 caws, 10 pigs and his touristic capacities. There was not a lot of tourists in Stefan's time when the agricultural machines were rare and inadequate, while otherwise just nothing profoundly changed.

Date	Time	Location	Name	Other
25 Nov 1790	10:00	St. Kazian	Georg Stephan	
25 Nov 1790	10:00	St. Kazian	Anton Loschmidt	
25 Nov 1790	10:00	St. Kazian	Josef Loschmidt	
25 Nov 1790	10:00	St. Kazian	Caroline Magdalena Barbara Mayr	
25 Nov 1790	10:00	St. Kazian	Josef Karl Loschmidt	

Figure 22-19: Funeral of J. Stefan's great grandfather Georg Stephan on 25 November 1790.

Date	Time	Location	Name	Other
1785			Apolonia Olipp	
1785			Parents	
1785			Godparents	

Figure 22-20: Baptism of J. Stefan's maternal grandmother Apolonia Olipp in 1785.

Jožef Stefan's mother Maria was the fifth of eight kids of country craftsmen who became a proletarian in the process of industrialization of early 19th century. She had to serve as farming helping hand in wealthy guys' farms around Klagenfurt to earn her daily bread. Jožef Stefan's father was next to the youngest of seven children, so he had to learn some craft in the suburb of nearby Klagenfurt. Čermelj's data of illegitimate birth of Jožef Stefan's father are false.²⁷⁴⁷ Čermelj probably made his error because J. Stefan's grandfather Joannes Nepomuk Stephan (1753-1810 Lancova-Lanzendorf 5 Škocjan pri Podjuni (Sankt Kanzian am Klopeiner See in Jauntal)) died so early as he was for more than two decades older than his wife, J. Stefan's grandmother Elizabet

²⁷⁴⁷ Čermelj, 1976, 10.

Starmushin (1774-1846 Lancova-Lanzendorf 5 Škocjan pri Podjuni (Sankt Kanzian am Klopeiner See in Jauntal)). J. Stefan remembered his randmother well and visited her in Lancova-Lanzendorf farm at No 5 Škocjan pri Podjuni (Sankt Kanzian am Klopeiner See in Jauntal), but even J. Stefan's mother never saw his grandfather Jožef Stefan's father had no chance to inherit his native farm with all those elder brothers around. He had to learn some craft and milling was good as any other. When he met his almost a decade younger neighbour Marija Startinik (Sertizek) from Dollinch no. 9 of parish Glinje by Borovlje, she worked as a maidservant in the house-farm of Josip Geiger vulgo Franzl in St. Ruprecht or ore exactly in nearby hut nicknamed Franzlkeusche (Franzl's shack (kajža)). Josip Geiger could be probably connected with the modern Gasthof Geiger in Bad Sankt Leonhard im Lavanttal. Marija Startinik was from the prosperous manufacturers' family which preferred the traditional carpenter business around Borovlje (Ferlach) for many generations. Her mother's ancestors were all in traditional gunsmith trade which was and still is very successful business around Borovlje (Ferlach). Jožef Stefan was born in St. Peter in district (Bezirk) Ebenthal suburb of Klagenfurt in Ebentalerstrasse no. 19 on 24. 3. 1835 at 8 p.m. Josip Geiger was the owner of that family house St. Peter no. 19 while he also owned no. 11. A kid Jožef (Josef) was born in lateral building of St. Peter no. 19 where his mother lived as a maidservant. The house belonged to the Klagenfurt suburb mayordom of St. Rupert.²⁷⁴⁸

Next day on 25. 3. 1835 at 3:30 P.M. the newborn kid was baptized in the Klagenfurt church of St. Lorenz east of the Klagenfurt downtown.²⁷⁴⁹ In index, his baptism was first noted as Startinick Josef ill(egal), but later repaired into Stefan Josef after he was legitimized in 1840s. Many others did not have that luck.²⁷⁵⁰

Josef's midwife was Theresia Staskier from Volk: Vorstadt Klagenfurt no. 10 Wohnstat. His godfather was Joseph Hebernigg (Habernigg)

²⁷⁴⁸ Čermelj, 1976, 9.

²⁷⁴⁹ Klagenfurt-St. Lorenzen K20_005-1 (book of births) V page 54.

²⁷⁵⁰ St-Lorenzen/K20_005-Alph. Index zu den Geburtsbüchern, Kopie K20_037-1. His mother was noted as: "Maria Startinik Dienstenege, gebürtig in der Pharr Gleinach Bez: Hollenberg des Gregor Startinik Tichlers (carpenter)..."

vulgo Gartner. He was a settler (Kauschler, Gartenkeuschler) from St. Peter Ortschaft nearby. He was married to Maria Rabasser who performed his godparent duties for him. She was probably related to J. Startinik-Stefan's great grandmother Helena Rabitsch from Ottrouz. Josef Startinik-Stefan's godmother was Ana Startinik (Anna Startinigg), the younger sister of his mother. J. Stefan's godparents were not some wealthy guys who could indicate that J. Stefan-Startinik's father might be a rich man.



Figure 22-21: Baptism of J. Stefan in 1835.

J. Stefan-Startinik's father was noted as flour-trader (flour-merchant, Mehlhandler), a legitimate son of a farmer (Bauer) born in neighboring parish of St. Kanzian (Sankt Kanzian). On 16 August 1843, Josef Startinik-Stefan nearly got his eight years younger first cousin from his godmother Ana. As unmarried single seamstress (Ledige Nahterin) Anna gave birth to the dead boy. She was noted at Klagenfurt-St. Lorenzen church baptisms as: "von Ebenthal gebürtig, Tochter der Gregor Startinigg Zimmerman & Appolonia in Ebenthal gebürtig". Hebamme (midwife) was Anna Arschitz, but she had no luck. The priest Simon Heber (Hebamn) performed the baptism of poor kid who lived just for few minutes (Morth-Getauft, page 63, Klagenfurt-St. Lorenzen baptism book Geburtsbuch VI). Ana (Anna) lived in Volk. Vorstadt (Folk's Suburb) no. 46 in the suburb of Klagenfurt not far from her sister Maria and Maria's little son Jožef Stefan. None of both sisters got any other children at least they did not have them baptized at Klagenfurt-St. Lorenzen church. Both sisters had problems. Maria was from parish Gleinach while Ana was from Ebenthal to where their parents moved after Maria's birth, certainly in

1815 or 1816. Maria worked as maid-hand on a farm, while Anna was a seamstress in the sewing trade. Their younger brother Simon was born in 1820, but again in the different place in baron Rosenberg's castle Rossenegg no. 2 of parish Ebenthal which tells about the frequent resettlements of their father carpenter Gregor Startinegg from one job to another while fathering at least eight children to his productive wife Apolonia. Gregor and Apolonia's first children were born in Ferlach (Borovlje) no. 44, 42 or 43, the next one in Dollinch no. 9 of Glinje by Borovlje. Anna appeared in Gradnitz no. 17 of parish Ebenthal, Simon was born in Rossenegg no. 2, parish Ebenthal and the last child came to this world again back in Ferlach no. 56 domestically called Umniggin. Their father's most prosperous job might have been carpenter and settler (Zimmerman und Inwohner) position in Rossebegger (Rossenegg no. 2, Kedusche, today pub Rosenegg) castle built by baron Rosenberg in Fieberbrunn in Tirol 30 km northwest of Stadt Zell am See of Salzburg areas. Their son Simon had his funny godparents there: Simon Rinkisch vulgo (domestically nicknamed) Rossenegger from the castle and Anna Stephun vulgo Lamglind. The family Stephun might have been remotely related to the family Stefan (Stephan). In 1760s the silverer Johann Michael bought the resold Rossenegg to develop the brewery and a restaurant in the castle. In 1769 the castle was sold again to a mining trust from Salzburg which housed their stewards in the castle. In 1820 when Simon Startinek was born there, the castle Rossenegg was in possession of its last private owner, namely Franz von Lürzer. Lürzer gave Gregor Startinigg some temporary carpenter's job there. In 1842, the castle became the Habsburg k.k. Oberforstamt in Rosenberg as a centre of local forestry.

Gregor Startinigg had something like that travelling carpenter business put into his cradle as he was fifth of six children but the only one whose baptism was for one reason or another not noted in his parents' house Dollinch no. 10 nicknamed (vulgo) Zimmerman in parish Glainach=Glinje. Certainly, he never went far except for Fieberbrunn in Tirol 200 km northwest from Klagenfurt. Otherwise he worked mostly around the central Carinthia in suburbs of Klagenfurt, Ebenthal, Gleinach and Ferlach (Borovec) full of firearms production which needed a carpenter hand for the wooden parts of the guns. Jožef Stefan's

experimental skills was a heritage of many carpenters, metal workers as wire pullers at the city silver nail manufacture of Ferlach²⁷⁵¹, and gunsmiths among his ancestors, especially those from Ferlach (Borovec).



Figure 22-22: Baptism of J. Stefan's uncle Simon Startinek in 1820.



Figure 22-23: Baptism of J. Stefan in index of baptisms where he was noted under his unmarried mother's family name.

Maria Startinigg inherited some of her father's travelling business soul. Maria's alleged lover Alex (Aleš) Stefan worked at the "Großnigbauer" of Franz Puntschart as a miller's assistant in the neighbouring settlement in Limersach (Limmersach, Limarče) not far from Geiger's house. Franz Georg Puntschart (1816–1872) also operated a mill as well as another mill on the Glan river and collected paintings of his factories. The Puntschart family even owned the white-lead factory in Ebental by Klagenfurt. Franz Puntschart who died in 1890 opened subsidiary company in St. Veith in 1858. His business was granted several awards for the quality of his product until it was closed in 1890. The industrial revolution with accumulation of the capital, changing of landscape with factories, and wondering poor proletariat was

²⁷⁵¹ page 74 of F05_022-1 Ferlach Sterbebuch IV on 21. 8. 1848 noted J. Stefan's grandfather's first cousin Joseph Startinik (1771-1848 Ferlach no 42) who worked as the puller of wires at the city silver nail manufacture (Dracht Zieher an der B.(Burgerliche) Silber Nagel-schen Gewerkschaft.

in full advance in J. Stefan's juvenile years. The carpenter business of his countryside ancestors was in disadvantage compared to the city carpenters because just town carpenters were able to keep their guilds during the era of Vormarch.

Maria's younger sister Anna Startinick also worked for Franz Puntschart in the nearby town of "Limersach (Limmersach, Limarče)" as a servant girl at the Großnighof according to Westritschnig's data published in 2012. Therefore, she abandoned her earlier sewing craft for a servant job resembling the one her elder sister Maria had. The owner of the Großnighof and the mill on the Glan river was the big farmer and miller Franz Puntschart. Therefore, Anna Startinick used to work for the same boss as did her sister's lover Aleš (Alex) Stefan which enabled Anna to play the role of a kind of in between messengers of the illiterate but devoted sweethearts. Puntschart was a great boss and his family was too mighty to use Glainach (Glinje) church for their weddings and baptisms. Puntschart was a great businessman worldwide while the Geiger family was prominent only locally although Geiger was also well-to-do guy. The gap between the folks who had enough capital to use the opportunities of the early industrial revolution and the other who did not widened very quickly. J. Stefan's ancestors were on the wrong side of moneymaking luck.



Figure 22-24: Baptism of J. Stefan's aunt and godmother Anna Startinick in 1817.

J. Stefan's father could have confessed to the priest that he fathered a child at the first place as it is hard to recognize any deep difference between the inks in notes of J. Stefan's father and J. Stefan's mother in J. Stefan's certification of baptism. But in the index of baptisms the kid J. Stefan was noted as illegitimate child with his mother's surname, so

the father was certainly added somewhat later, maybe only after the legitimization of a kid. The priest usually left the blank rubric for fathers always in hope for legitimizations, but they didn't always get the willing men straightaway. Some funny priests even kept their separate books for the baptisms of the illegitimate kids as a threat for their illiterate believers and their secret prohibited love stories. J. Stefan's father traded with flour²⁷⁵² and sold his stuff as traveling merchant without a fixed home position before he prospered enough to marry J. Stefan's mother and enable J. Stefan's chances of advanced studies.



Figure 22-25: Sad funeral of J. Stefan's youngest aunt, the six years old Katharina Startinik in 1829.



Figure 22-26: Marriage of the house owner and boss of J. Stefan's mother named Josip Geiger in 1838.

When Jožef Stefan was a little over three years old, there was a huge fest in his boss' house. Josef Geiger and Maria Strutz's son Josip Geiger married Maria Schnitzler (* 1817) at St. Peter no. 19 on 30. 7. 1838. The groom was „the owner of technical plate separator or constructor at Grafenstein as a son of still living Ferlach owner Joseph Geiger of Peterheb No. 19 Besitzer der Scheider nach Hause zu Grafenstein (Grabštajn 12 km east of Klagenfurt) sub Haus No. 11 des nachlebenden Joseph Geiger Besitzer in Ferlach

²⁷⁵² Čermelj 1976 10.

verliebte unter allen Peterheb No. 19.“ One of the marriage witnesses was illiterate Matias Jäger.²⁷⁵³

22.2.3 *Marry or not to Marry, That is the Question on the Eve of Spring of Nations Revolutions in 1848*

The fathering of illegitimate children was a kind of habit in the family of J. Stefan's father which probably provided some obstacle for the marriage of juvenile Stefan later. The youngest of J. Stefan's uncles, Aleš's younger brother Mihael Stephan (* 29 September 1802 Lancova no 5 Škocjan pri Podjuni = Lanzendorf Sankt Kanzian am Klopeiner See in Jauntal) also fathered an illegitimate kid named Simon Jarz (*3 April 1842) in Sankt Kanzian (Škocijan) no. 8 near Eberndorf (*Dobrlava*) east of Klagenfurt. He loved a peasant girl from a farm nicknamed (vulgo) Skrutel of Sankt Kanzian (Škocijan) no. 8. The nice maid was Barbara Jarz. The mother of family Jarz with that nickname could be related to Gaspar Skrutel and Maria's farm of Eberndorf no. 11 where their legal son Sebastian Skrutel was born on 19. 1. 1820 in Eberndorf no 5 vulgo Kanzian. The other family Skrutel had their kids born there on 24. 10. 1827 and on 22. 5. 1836. There were two illegitimate kids named Simon born in Eberndorf parish up to 1836. The illegitimate Ana Puschel's son Simon Puschel was born in Gösslssdorf no 15 of Eberndorf parish on 23. 10. 1829. On 22. 10. 1832 in Eberndorf Simon Puljer and Agnes Maiserl's daughter Maria gave illegitimate birth to Simon. Jarz family had no baptisms in Erberndorf parish of those times, but there was the similar Janzko family in Eberndorf no. 24.

On 14th March 1883, Jožef Stefan's first cousin named Simon Jarz married sixteen years younger already for six months pregnant very willing girl Anna Rigelnik on the farm Eberndorf no. 11. There Simon Jarz and Anna had three daughters and finally also a son Simon in 1883-1891.²⁷⁵⁴ Simon Jarz probably helped in the farming in Eberndorf no. 11 and did his job all too good. It did not help much that there in Völkermarkt (Velikovec) District of Jaun (*Podjuna*) Valley the Jesuits used to have their main residence with the huge noviciate for the successful financing of their

²⁷⁵³ K20_016-1 Trauungsbuch II Klagenfurt St. Lorenz 2: 71; Geburtsbuch III K20_003-1 Klagenfurt St. Lorenz 3: 5.
²⁷⁵⁴ E02_008-1 Geburtsbuch Eberndorf pages 48, 76, 96.

Klagenfurt college up to 1773. Mihael was even somewhat worse than his younger brother Aleš, as Mihael never bothered to marry his lover at all which was certainly not the behaviour which the Jesuits approved.

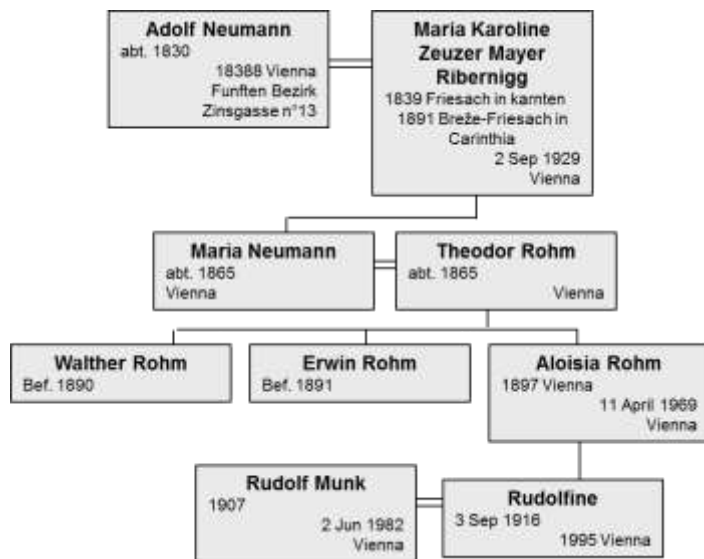

Figure 22-27: Descendants of Stefan's wife.



Figure 22-28: Marriage of J. Stefan's first cousin, Simon Jarz in 1883

The dreams of J. Stefan's mother that her boss could marry her were finally over for good. Did she like her Geiger boss anyway? Had Josip Geiger anything to do with Josip Stefan's birth at all? If yes, Josip Geiger was certainly able to pay for Jožef Stefan's studies, to give him a proper surname after arranging J. Stefan's marriage which was certainly condition sine qua non for his studies. Josip Geiger died just few weeks after Jožef Stefan, but in his later years after his mother and father died in 1865-1872, J. Stefan ceased to visit Carinthia until his own marriage which had allegedly something like reprise in Breže (Friesach) votive church of Carinthia in 1891. J. Stefan's bride was Maria (1830-1929) supposedly from Friesach in Carinthia (Kärnten), the widow of Adolf Neumann. She might have been related to

Loschmidt's wife Caroline Mayr as Maria's maiden name was Zeuzer, Mayer, or Ribernigg which were the family names of all girls named Maria who were born in Breže on 1839 except for two girls named Maria who died very young.



Figure 22-29: Loschmidt's marriage in Votive-Church in 1887.

On 10 December 1887, Stefan's long-time roomie the sixty-six years old Josef Loschmidt (married his long-time lover and housekeeper unmarried (Ledig) Caroline Magdalena Barbara Mayr (1846 Bozen-13. 2. 1930) for the next eight years of their married happiness and Stefan followed his example four years later. In Vienna, Loschmidt's quarter of century younger wife Caroline hosted her nephew's wife or her niece Karoline Mayr (23. 2. 1885-13. 12. 1950) who was not baptized in Votivekirche. Loschmidt and Caroline decided to marry only after their son was on his way to be born to enable his future studies, but they did not think about their age as they were more than a century old altogether when the poor sick kid was born. Loschmidt's best man was a chemist Ludwig Barth von Barthenau (17. 1. 1839 Rovereto in Trentino-3. 8. 1890 Vienna) who served as a Dean of Viennese Faculty of Philosophy in 1885/86 and has a monument in arcaded court of faculty of philosophy erected in 1892. Ludwig Barth Ritter von Barthenau studied chemistry in Munich with Liebig (Dr. phil. 1860). He joined military missions in lost Sardinian war in 1859 in Academic Legion and in lost war against Prussians in 1866. Barth was a professor in Innsbruck in 1867 and moved to Vienna in 1876 as Professor of Chemistry at the University of Vienna where he taught until 1890. In 1876 he became a corresponding member, and an ordinary member of the Academy of Sciences (Math.-naturwiss. Class) in 1879. In 1880 Barth was a co-founder of the "Monatshefte für Chemie". Barth was a member of the Supreme Medical Council, promoted the Austrian Pharmacopoeia, discovered the resorcinol and successfully researched benzene derivatives as well as the action of potash fusion melt on organic substances. He was k. k. Hofrat and lead the executive committee of the Chemistry

Laboratory. As an alpinist he explored the Stubai (Stubai) Alps mountain group published in a monograph. In 1887, Barth lived in 9th Bezirk Wassergasse no. 9. The other Loschmidt's best man was Lawrenz Schons (Sohous, Sotious) k.k professor in pension from 2nd Bezirk Franzenbrukensreasse no. 24 who previously lectured in Viennese High School and had Bohemian ancestors according to his family name. J. Stefan was a good Loschmidt's friend, but not good enough for his best man.

Less than two months after their marriage their son Josef Karl Loschmidt was born. As he was not a strong child, he was baptized only after a month in Votive church. His godparent was Josefa Platider (Plakider) as shareholder (Winkschäfterin, Wintschäfterin) from Wassergasse no. 9 at Barth's 9th Bezirk. The midwife was Leopoldine Schima from Währing Hauptstrasse no. 17. J. Stefan was again not considered as a godfather.

The other Karoline Mayr lived as a widow of Sector Rath (Sector Counsellor) under the name Karoline Mayr-Miller in 3rd Bezirk in Rennweg no. 3. Sadly enough, Loschmidt and Caroline Mayr's only son Josef Karl Loschmidt (18. 2. 1888-23. 6. 1898) had a funeral on next day after he passed away.²⁷⁵⁵ The poor son Josef Loschmidt had died soon after his father at the age of ten of Scarlach (scarlet) after his sickness in his family home in Gentsgasse no. 65. For his final days Josef Loschmidt was transferred to the children hospital in Kinderspitalgasse no 6 with a funeral ceremony performed in nearby Waehring (Währing) on 24. 6. 1898 (not on 27. 6.!). His baptism, his father's marriage or his father's funeral were not in that church three years earlier because the poor kid was eventually put in that church only because of convenience as the children's hospital he died in was near and the hospital usually used that church for funerals, while the family Loschmidt mostly used for their ceremonies some other Viennese church outside their domestic 18th Bezirk.

Caroline Mayr married Loschmidt died just few months before J. Stefan's widow Maria. Loschmidt

²⁷⁵⁵ in 18 Waehring by Sterbebuch 03-18 page 57 (no funeral was noted in 18 Gersthof Sterbebuch 03-03 or 18 Poetzleinsdorf Sterbebuch 03-02; 1887 Votivkirche 9th Bezirk page 48 marriage note 136, 1887 Votivkirche 9th Bezirk has baptism listed at page 5 5 note 13; Adolph Lehmann's allgemeiner Wohnungs-Anzeiger 1885 p. 685.

once wrote his paradox on banknote in a pub for Boltzmann and Stefan. Until Loschmidt's marriage, Loschmidt and Stefan lived together in their official laboratory and classroom building at Türkenstrasse no. 3 in 9th Bezirk of Vienna called Alsergrund.²⁷⁵⁶ In 1887, as a married man with a son, Loschmidt moved to the new location nearby in the same 9th Bezirk Alsergrund in Schwarzspanier-Strasse no 18, but Loschmidt's kid was not baptized in any of three churches in that Loschmidt's 9th Bezirk in or in his newly married wife's former 3rd Bezirk.²⁷⁵⁷ For Boltzmann, Loschmidt was a type of scientist without a real touch with reality, but in that love-affair case Loschmidt proved Boltzmann's error. Stefan was certainly a little bit jealous upon the success of his long-time friend and collaborator, therefore he soon began to courtship the new housekeeper who replaced Loschmidt's pregnant wife after her previous husband died. The authorities were certainly clever to hire all the time the very best middle-aged housemaids for those funny clever bachelor physicists and Stefan was soon in the net.



Figure 22-30: The baptism of Loschmidt's only son in Votive-church in 1888.

Upon Stefan marriage, in October 1891 Loschmidt retired to his quiet family life in favour of the new boss of *Zweites Physikalisches Institut* Franz-Serafin Exner (1849 Vienna-1926 Vienna). Loschmidt lived in XVIII Bezirk Whn. (=Währing) at Johannesgasse no 5 in north-western Vienna as retired professor in the year 1892. He received an order of iron crown for his merits. In his final last years he suffered a lot in his last very modest flat in Lacknergasse of 18th Bezirk Währing where Boltzmann visited him and sarcastically declared

²⁷⁵⁶ Adolph Lehmann's allgemeiner Wohnungs-Anzeiger 1885 p. 651; 1886 p. 652.

²⁷⁵⁷ Adolph Lehmann's allgemeiner Wohnungs-Anzeiger 1887 p. 674; 09 Lichtental Index Taufen A-07; 09 Rossau Index Taufen A-02; 09 Votivkirche Taufbuch 01-03; 03 Rennweg - Maria Geburt Taufbuch 01-19; 03 St. Othmar unter den Weißgerbern Index Taufe A-01; 03 Landstrasse - St. Rochus Taufbuch 01-64; 03 Erdberg, St. Peter und Paul Taufbuch 01-28b.

that's the way how Habsburg pay their great man. In 1894, the street was named after Matthias von Lackner just few months before Loschmidt passed away there. Loschmidt's funeral was not in any of the churches of XVIII Bezirk Währing. Loschmidt's widow still lived in 18th Bezirk Währing but in Gentzgasse no. 68 (65) upon the death of her kid in 1898. In 1894 that street was renamed to Metternich's fellow politician known for his bisexuality Friedrich von Gentz (1764-1832). Before that time in 1892, Stefan lived in his official rooms in Türkenstrasse no. 3 as member of information trust for public curricula of religion and sciences (Mittglied der Normal-Aushangs-Emsn. EZ für Kultus und Wissenschaften, Offic, de l'instruc. Public).²⁷⁵⁸

Stefan's bride was a widow of comparatively important official Adolf Neumann. Adolf's relative Friedrich Neumann began to work for the developing local railways (Staatseisenbahn-Beamten) as the inspector of railways in Villach in 1883, the railway Ober inspector in Linz in 1884-1887 and finally in Bureau 4/e für den Wagen-Control (in 1888, transformed into Wagendienst in 1889 and after) of k.k. General Direktion der österreichische Staatsbahnen in Wien. Friedrich Neumann was still at work as Staatsbahndirektors in 1891 but no more when the other Ober inspector Victor Marek replaced him in 1892.²⁷⁵⁹ Friedrich Neumann did not have a funeral in Viennese votive church as did J. Stefan less than two years later. In 1859 the Votivkirche was erected very close to Stefan's flat to commemorate the failed assassination attempt focused on emperor's brother, who met his firing squad in Mexico anyway.²⁷⁶⁰

²⁷⁵⁸ Adolph Lehmann's allgemeiner Wohnungs-Anzeiger 1892 p. 777, 1142; 1898 p. 684 (wrongly noted Loschmidt Karol (Sic!) Univ. Prof. Wwe. (=window)).

²⁷⁵⁹ *Hof- und Staats-Handbuch des Österreichisch-ungarischen Monarchie für...*, Wien: Hof- und Staatsdruckerei, 1883: p. 100; p. 1884: p. 107; 1885: p. 115; 1886: p. 115; 1887: p. 116; 1888: p. 371; 1889: p. 375; 1890: p. 380; 1891: pp. 385, 390; 1892: p. 299; 1.

²⁷⁶⁰ Wien 08., Votivkirche Sterbebuch 03-04. Friedrich Neumann was not identical to Friedrich von Neumann Eisenhändler und Fabriksbes. member of k.k. Permanenz-Comission für die Handelswerthe. or to Friedrich Neumann Betriebs-Direktor der österreichische Staatsbahnen who was holder of Franc Josef-Orden Medal-Decoration *Hof- und Staats-Handbuch des Österreichisch-ungarischen Monarchie für...*, Wien: Hof- und Staatsdruckerei, 1891: p. 390; 1892: p. 139, 303; 1893: 139, 310.

Most source²⁷⁶¹s noted Maria's husband Neumann as Adolf, while no Adolf Neumann appeared among the listed state or court employed inspectors of railways in the Habsburg empire high positions of those times. In fact, no Adolf Neumann was employed in Habsburg court or state jobs in 1858-1892 as Maria's husband Adolf Neumann from Friesach in Kärnten (Breže in Carinthia) probably worked for private Rothschild's railway company. In 1859, Adolf Neumann was not noted as engineer among the Viennese inhabitants. In 1860-1861, the engineer assistant Adolf Neumann lived in the Viennese Penzing Haupt Straße no. 93. In 1864, the engineer assistant Adolf Neumann lived in Bhschg. (Bischof Gasse Meidling 12th Bezirk) no. 197. In 1865, the engineer assistant to West Railway Adolf Neumann lived in the Viennese Rstd. (Rudolfstadt) no. 197. In 1867-1876, the engineer assistant to West Railway (bei Westbahn) Adolf Neumann lived in Rdlföh. (fifth district called Margareten) Schönbrunnerstrasse no. 19. In 1877-1881, Adolf Neumann was the Ober engineer der Wien Bahn (1877, 1878, 1880, 1881) and later Ober engineer der k.k. Dir. für St E Bahn Betr. in 1882-1885. In 1877-1885 Adolf Neumann lived in Fünf. Bezirk (fifth district called Margareten) Schönbrunnerstrasse no. 10, at least in 1881-1883 together with his son-in-law residing at the same address. Adolf Neumann was there no more in 1886 as he moved to a better flat. In 1886, the inspector der k.k. Gen. Dir. der (österreich.) St. Bahnen (Österreichische Staat Bahnen, State Roads) Adolf Neumann lived in VII Bezirk Neubau in Zollergasse no. 6. In 1887-1888 he lived in 15th Bezirk (Fünfh.= Fünfhaus) Rudolfsheim-Fünfhaus Zinkgasse (Zinckgasse) no. 13. In the year 1889 he no more lived there and his widow Maria did not take over the flat. J. Stefan's stepdaughter Maria Neumann also did not take over that flat. Although many other Neumanns lived and died in 15th Bezirk, Adolf Neumann did not have his funeral ceremony in any of both churches of 15th Bezirk, Reindorf or Fünfhaus, in 1887-1889. Adolf Neumann's baptism, marriage or funeral was not noted in Friesach in Kärnten,²⁷⁶² and his funeral was not listed in Viennese votive church or in Viennese Catholic or Jewish cemeteries.

Adolf Neumann's daughter Maria Neumann married Theodor Rohm. Theodor Rohm was not

²⁷⁶¹ Sitar, 1993, 103; Karl Josef Westritschnig. 2012 .

²⁷⁶² Breže in Carinthia, Index zu Trauungsbuch Friesach=Breže F11_023-2, 3-7-594_00030.

noted as a person living in Vienna in 1876-1880. In 1881-1883, Theodor Rohm was an accountant (Buchhalter) of baron Rothschild's domains and lived in his father-in-law flat in 5th Bezirk in Viennese Schönbrunnerstrasse (Schönbrunner Straße) no 10 of 5th Bezirk Margareten just east of 4th Bezirk Wieden which contained Schönbrunner Straße up to no. 9. In 1884-1886 he kept the same job but left his father-in-law flat and lived in the Viennese VIII Bezirk in Piaristengasse no. 15. In 1889 Theodor Rohm advanced in Rothschild's networks to become a Cassa-Amt. der Bankhauses S. M. von Rothschild (Salomon Mayer von Rothschild, 9 September 1774 – 28 July 1855), in fact of his grandson Albert Salomon Anselm baron Rothschild (October 29, 1844 – February 11, 1911) who owned the Viennese Kreditanstalt (Creditanstalt) and the first Habsburg railway called Emperor Ferdinand Northern Railway (*Kaiser Ferdinands-Nordbahn*, KFNB). In the year 1889 Theodor Rohm lived in the Viennese VIII Bezirk in Piaristengasse no. 15, and he was a private Beamter (Official) in Viennese VIII Bezirk in Florianigasse no 44 on the north of his former apartment in the year 1892. In 1890-1892, Marie Neumann as the Bahn-Inspector's widow lived in Fifth Bezirk Margareten in Schönbrunnerstrasse no 5, which later became 4th Bezirk Wieden up to Schönbrunnerstrasse no 9. She was no more noted there in 1893 and later because she married J. Stefan in 1892.²⁷⁶³ That could mean that Adolf Neumann's flat in 15th Rudolfsheim-Fünfhaus Bezirk Zinkgasse (Zinckgasse Fünfhaus) no. 13 belonged to his railway company, probably the North Rothschild's one, and his widow did not inherit it as she preferred to move nearby to the same fifth Bezirk near their old flat because she settled in Schönbrunnerstrasse no. 5.

What about J. Stefan's marriage? In 1875, Bismarck introduced civil common-law marriages in newly unified Germany, but that French revolutionary or British habit was not introduced in Austria before the Anschluss of 1. 8. 1938. There

²⁷⁶³ Adolph Lehmann's allgemeiner Wohnungs-Anzeig 1859 p. 555; 1860 p. 10; 1861: 221; 1864: p. 317; 1865: 225 left; 1867: 222; 1868: p. 536; 1870: p. 315; 1871: p. 291; 1875: 382; 1876: 388, 450; 1877: 597; 1878: 640, 746; 1879: 726; 1880: 643 middle row, 749; 1881 pp. 675, 786; 1882 p. 686/middle row at bottom; 1883 pp. 685/left, 797 left; 1884 pp. 690/left, 803 right; 1885 p. 727 left bottom; 1886 pp. 727 left, 845 left; 1887 p. 748; 1888 p. 778 left row at bottom; 1889 pp. 812, 813, 836; 1890 pp. 815, 816 right; 1891: 837 right; 1892: pp. 865 middle, 998; 1893: 1657 middle

Figure 22-31: First husband of J. Stefan's wife the inspector Adolf Neumann on page 727 left, 7th from the bottom in 1886.²⁷⁶⁴

Figure 22-32: J. Stefan's future wife Marie Neumann as the widow of the inspector Adolf Neumann on page 816 right 28th from the bottom living in Schonburgerstrasse 5 and waiting for J. Stefan as his housemaid in 1890 J. Stefan's was already courting that willing widow by then, although he should better wait a little bit.

was no real possibility for civil marriage for J. Stefan even if he wished to have one in Habsburg monarchy in 1891-1892. Anyway, J. Stefan's marriage was not noted in Breže,²⁷⁶⁵ Klagenfurt or nearby, and not in major Viennese churches including the Votive church in Vienna where he had his funeral ceremony somewhat more than a year later, or in other churches in Stefan's domestic Viennese Bezirk. J. Stefan was not married in the Viennese churches of the district where he and his fiancé used to live.²⁷⁶⁶

After the marriage, the new Stefan couple still resided in Türkenstrasse no. 3. After Josef Stefan

²⁷⁶⁴ Adolph Lehmann's allgemeiner Wohnungs-Anzeiger.

²⁷⁶⁵ Breže in Carinthia, Index zu Trauungsbuch Friesach=Breže F11_023-2, 3-7-594_00041.

²⁷⁶⁶ including Stefan's current 9th Bezirk Alsergrund with churches 09 Lichental Index Trauungen B-03, 09 Votivkirche or 09 Rossau Index Trauungen B-02, Stefan's former 3rd Bezirk Landstraße-Erdberg where he lived up to 1875 with churches 03 Erdberg St. Peter und Paul Trauungsbuch 02-14, 03 Landstrasse - St. Rochus Trauungsbuch 02-23, 03 Rennweg - Maria Geburt Trauungsbuch 02-13 and 03 St. Othmar unter den Weißgerbern Index Trauung B-01 or in his spouse's domestic 5th Bezirk Margareten where she lived until marriage with churches 05 St. Florian (Matzleinsdorf) or 05 St. Josef zu Margareten Trauungsbuch 02-25.



Figure 22-33: The funeral of the husband of J. Stefan's step-daughter Theodor Rohm in Maria Treu church in 1907.

was in nearby Maria Treu church of 8th Bezirk, north of Friars Minor Conventual monastery (Minoriten kloster). He was killed by the degeneration of his throat (Entartung des Rachens). He was buried in cemetery (Friedhof) Baumgartner on 12. 1. 1907. Theodor Rohm's father was a foreman master (Stürseher maister, Stürschermaister) in Bohemia in 1879. Theodor Rohm's younger brother Maximilian Eduard Rohm (* 30. 1. 1855 Neustadl (Náchod or Nové Město nad Metují) in Bohemia) was also the Viennese accountant (Buchhalter) in 5th Bezirk Margareten, at Grüngasse no. 25 just one block north of Theodor Rohm's Schönbrunnerstrasse. Therefore, the brothers in the same business get along very well, although Theodor Rohm was never a godfather to any of his nephews or nieces born in Viennese Grüngasse no 25 of 5th Bezirk in their domestic church St. Josef zu Margareten in 1881-1884. Maximilian Eduard Rohm got that flat in Grüngasse no 25 upon marriage and lived there with his father-in-law the master carpenter Ignaz Kreutz, his wife Maria Eva Siebert and their younger unmarried daughter Theresia Kreutz. Theodor Rohm got his first flat in Schönbrunnerstrasse no. 10 in fifth Bezirk in the same way upon his marriage as did his brother Maximilian Rohm. Theodor Rohm lived there with his father-in-law at least in 1881-1883, when his son Theodor Rohm (1883-27. 1. 1953) was born; Theodor Rohm junior died when he was 70 years old in the Viennese district of Hernals. They were all not far from J. Stefan's flat, that's why J. Stefan expected a great Christmas tree in 1892.

Theodor Rohm's boss was Miksa Déri (Max, 1854 Bács (Bač in Vojvodina-1938 Merano). The merchant Moritz Deutsch's son, Miksa Déri began his studies at the TU in Pest (Budapest) and continued from 1873 at the TH Vienna with his absolutorium in 1877. Until 1882 he worked on

river regulation of the Danube and Tisa (Tisza) while he turned his attention more and more to electrical engineering. In 1878 in Budapest, Déri published the anthology of Faraday and Helmholtz's popular works. In 1882 Károly Zipernowsky, founder and head of the electrical engineering department of the Budapest company Ganz & Co., appointed Déri to his company. Among their joint inventions was a self-excited alternator (1883), in which the rotor was energized by rectified terminal voltage. The rectification was done by the rotor commutator mounted on the axis while a separate exciter machine was not necessary. The fact that the machine could be also used as a single-phase synchronous motor was very important in the "pre-rotation times" of the 1880s, because the distribution of alternating current was severely limited due to the lack of suitable motors. From 1883 on, Ottó Titusz Bláthy joined their efforts to develop step-down AC transformers while Tesla designed step-up AC transformers after all of them worked in Budapest in early 1880s which was a cradle of AC like it become the cradle of USA manufactured atomic om six decades later. The three Ganz geniuses patented their most important invention, the closed iron core transformer, in 1885. Other important inventions of Déri were the one- and two-phase Einankerumformer (1888, together with Zipernowsky), a compensated DC machine (1902), a single-phase repulsion motor and the Déri's motor (1904) with a fixed and a rotatable brush pair, in which the brush adjustment speed and direction of rotation could be changed. This engine was preferred in single phase networks and was used for passenger lifts. From 1883 in Vienna Déri was a representative of the Electrical Department of Ganz & Co. and Director of the International Electricity Society (IEG) in 1889-1896. The IEG was founded to finance power plants and their first power plant in Vienna was put in operation in 1890. In addition, he was a member of the board of the Austrian Union Electricity Company (Österreichischen Union-Elektrizitäts-Gesellschaft) and the Hungarian Electricity Company, as well as consultant to BBC, Stanley Electric and General Electric. Déri retired in 1923. He continued to work in the academic field. In 1908 he became a Hungarian court councilor, in 1910 he became a doctor of Technical Hochschule in Brno, and in 1913 he was appointed honorary member of the Electrotechnical Association in Vienna. Like

Tesla, he was born in later Yugoslavian areas whole he spent his last days in Tyrolean Merano.

The International Electricity Company (IEG) with J. Stefan's relative Rohm included was one of the three private electricity companies that received concessions for the construction of electricity plants in Vienna in the 1880s. After the concession was granted to it on March 27, 1887, the Wiener Elektrizitäts-Gesellschaft (WEG) entered direct competition with the Allgemeine Österreichische Elektrizitäts-Gesellschaft founded in 1889, and the Internationale Elektrizitäts-Gesellschaft. The IEG owned the steam-electric power station (Dampfzentrale 2) at Engerthstraße 199 (which was redeemed in 1908 by the city of Vienna during the municipalization of the power stations). It was built in 1890 according to Ganz & Co.'s transformer transmission system of Tesla's AC and expanded almost every year in line with the demand increase. The facility consisted of a machine shop, a parallel boiler house built directly next to it, a coal shed in the yard (above which were the workers' washing and dressing rooms and the dining rooms). Special precautions were necessary for the procurement of the required cooling water.

The success of J. Stefan's International Electricity Exhibition in Vienna (1883), which had already been preceded by exhibitions in Paris and Munich, aroused the need to use electrical energy for industry, commerce and traffic (electric motors) as well as lighting. Engineer G. Franz Fischer was the first in Vienna to apply for the concession for the construction and operation of an electrical central station and received it on 24 October 1885. Fischer transferred the concession in 1886 to the company Siemens & Halske in Vienna, because he did not have the necessary capital. He designed the lightning of Viennese streets by a contract with the municipality of Vienna. On 14 October 1887 this contract was completed, in September 1889 the central station in the city was put into operation. In 1891 the complex was transferred to the General Austrian Electricity Company (Allgemeine Österreichische Elektrizitäts-Gesellschaft), which was founded under the leadership of the Anglo-Austrian Bank to tackle a "Central Leopoldstadt" (2, Obere Donaustraße Nos. 23-27) due to the enormous interest. In 1918 the increase of connected customers demanded the design of additional steam power plant, later Umspann- and

cable workshop and central warehouse of the municipal E-Werke. On April 21, 1893 a road contract with the municipality of Vienna valid for the entire urban area was completed. In 1887 a rival company, the Viennese Electricity (Wiener Elektrizitäts-Gesellschaft (WEG)) was founded. It was followed by the International Electricity Company (Internationale Elektrizitäts-Gesellschaft (IEG)). Their only difference was that the General Electricity Company had the right to use the extended urban area (19th district) and the other two companies remained limited to the old city and suburbs (Vorstädte). The Allgemeine Österreichische Elektrizitäts-Gesellschaft had the following facilities: Central Neubad of 1st Bezirk in Neubadgasse no. 6, commencement of operations September 14, 1889; the central at Leopoldstadt of 2nd Bezirk Upper Danube Street no. 23-27 built by Wilhelm Schimitzek (* 1847 Silesia; †1914 Vienna) which commencement its operations on December 10, 1892; as well as substations at 17th Bezirk Helblinggasse 7, and 19th Bezirk Billrothstraße 2.

In 1900-1911, J. Stefan's widow still lived 8/2nd Bezirk but in Fuhrmannsgasse no. 17 as Marie Stefan k.k. Hof-Rath- und Universität Professor's widow. In 1912-1914, Marie as J. Stefan's widow (Steffan, Stephan, Steppan) and her son-in-law Theodor Rohm were not noted in Vienna. In Vienna there was Marie Rohm in 8/1 Bezirk Lammgasse no. 9 in 1908-1915 and no more in 1916, while Rosa Rohm as milliners (Modisten) resided in 8/1 Bezirk Piaristengasse 36 in 1913-1916. Marie Rohm was not noted as Theodor's widow as she probably appeared in Vienna as the independent inhabitant only after Theodor left (i.e. passed away) in nearby flat of their same 8th Bezirk. During her last years in 1915-1929 J. Stefan's widow lived in south part of 13th Bezirk/10 Hietzing (Speising) of Vienna in Gallgasse no. 17 near 12th Bezirk Meidling and 23th Bezirk Liesing as Marie Stefan Hofrath's Widow while none of her relatives with their family name Rohm were noted in Vienna in 1915. As Marie Stefan was very old, she probably did not die in her home, but certainly had a Christian funeral before the Anschluss. She was buried next to her husband J. Stefan in the Viennese Zentral Friedhof with her age stated as 90 years as a probably approximation, but no Viennese church

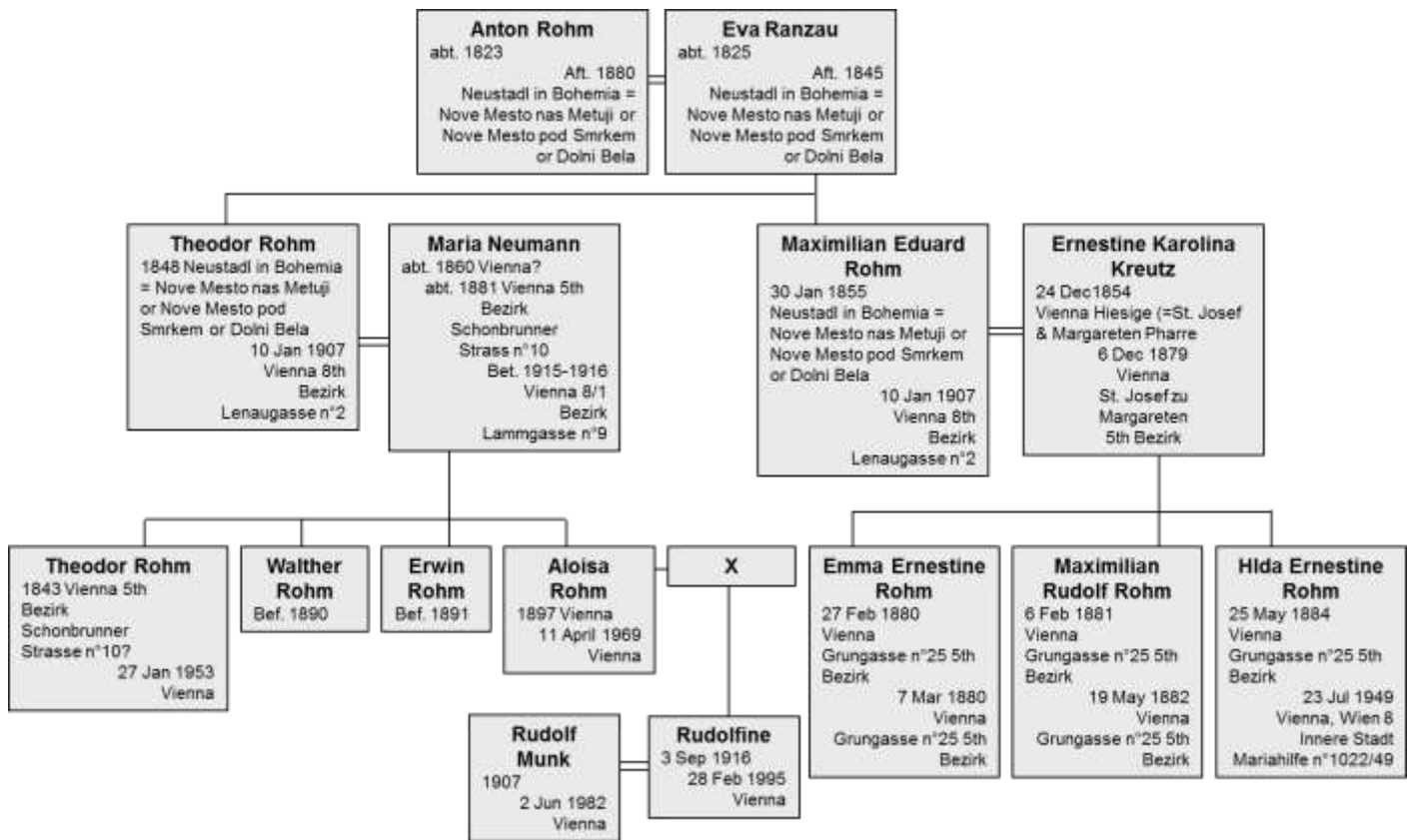

Figure 22-34: Theodor Rohm's family tree.

noted her funeral ceremony.²⁷⁶⁷ The genealogical researches of J. Stefan are not finished because his marriage notes are still not found in Vienna or in major Carinthia churches.

It doesn't sound that any of J. Stefan's colleague physicists were his marriage best man resembling Boltzmann who picked up his collaborator Toepler as his marriage witness in Graz while Loschmidt did the similar later in Vienna. J. Stefan's best friend was the Viennese city engineer Eduard Lukesch (Emil Luksch) in whose house J. Stefan suffered his final stroke in Viennese Razumovski street (Rasumofskygasse) no. 8 on 18. 12. 1892. That site is northwest from Stefan's residence lab on the other side of the 1st Bezirk Innerstadt. Eduard Lukesch from 3rd Bezirk Landstraße in Rasumofskygasse no. 8 was Ober Engineer der

²⁷⁶⁷ Adolph Lehmann's *allgemeiner Wohnungs-Anzeiger* 1893/2: page 1953 middle row; 1894/2: 873 right, page 1029; 1897/2: 930 middle, 1101 left; 1898/2: 951 right, 1125 middle; 1899/2: 975 right, 1152 left; 1900/2: 984 middle, 1163 right; 1905/: 1098 middle, 1297 right; 1907/2: 898 middle, 1061 left; 1908/2: 934 middle; 1909/2: 982 middle and right, 1161 middle; 1910/2: left 1196; 1911/2: 1241 left; 1912: 1267 right; 1913: 1086 right, 1285 left; 1914/2: 1106; 1915/2: 1106 right, 1037 right; 1920/2: 1299 middle; 1929/2: page 1584 middle; 1930/2: 1584.

Stadtbauamtes (City Construction Office) in retirement which was noted as pension abbreviated by (P.).²⁷⁶⁸

Jožef Stefan had good relationships with engineering groups, especially with the guys who were working in electrical engineering. Stefan's best friend and his wedding best man at J. Stefan's marriage with Maria Karoline, Emil Lukesch Eduard Lukež), was also an engineer probably in some private Viennese firm, maybe he even worked for Rothchild who employed J. Stefan's stepson. A guy named Emil Luksch worked as the Leiter des Bagatell-Ger. in Handels-Sachen of Rath-Sekretäre in k.k. Handelsgericht of Prague in 1889 and 1893.²⁷⁶⁹ The once humiliated Carinthia

²⁷⁶⁸ Sitar, 1993 104; Crepeau, 2013 8; Personalakt Jožef Stefan: Philosophischer Dekanats Akt der Universität Wien 1892/93, Archiv der Universität Wien, PH PA 3508. Reference code 151.248 Autographen auf einer Empfangsbestätigung der Universität Wien, 1874-1875 (Dokument (Einzelstück)); Adolph Lehmann's *allgemeiner Wohnungs-Anzeiger* 1892 p. 781 <https://www.digital.wienbibliothek.at/wbrobv/periodical/pageview/63909>.

²⁷⁶⁹ Leader of the minor commercial matters of Council Secretaries in k.k. commercial court Hof- und Staats-

native J. Stefan returned to his home areas to show how successful he became, but he got his deadly flu combined with pneumonia right away as he eat, drunk and breathed better but missed any sleep with his fatal fiancé... J. Stefan's heritage passed to the family Jandl of St. Ruprecht in Klagenfurt, less probably bei Völkermarkt (Št. Rupert pri Velikovcu) no 1 or 9 or more unlikely from St. Ruprecht bei Villach (Beljak). Alois Jandl from Pokersdorf married Theresia the daughter of Anna Startinik married Blasnik from the Carinthia parish St. Thomas by Zeiselberg and moved to St Rupert by Klagenfurt no. 32 nicknamed Timenitz. Because all Maria and Anna Startinik's older brothers and sister died in infancy, and probably Maria and Anna Startinik's younger brother Simon Startinigg (* 11th January 1820 Rossenegg no. 2 in parish Ebenthal) and sister Katherine Startniek (Starinik) did not produce much offspring, the family of Jandl in St. Rupert of Klagenfurt were the closest J. Stefan's relatives left. Jandl of St. Rupert of Klagenfurt are mostly physicians and politicians today.

Year	Name	Age	Sex	Parish	Other
1810	Joannes Stephan	3	M	St. Ruprecht	...
1810
1810
1810
1810
1810

Figure 22-35: Funeral of J. Stefan's grandfather Joannes Stephan as the third one noted in 1810.

It was a Vormarch time of Metternich's industrialization which transformed old-fashion occupants into impoverished proletariat including J. Stefan's family members of carpenters, flour-dealers, tailors, tobacco fabric workers and housemaids. Just some gunsmiths kept their prosperous businesses around Borovlje as they worked out small editions of precise good-looking shotguns for wealthy hunters. With March revolution of 1848 the American immigrant settlers' dreams joined the chaos which buried old ways of life. The sexual freedom in suburbs was amazing while the clever guys were inventing all kinds of industrial tools but no distinct urgently needed contraception at all also because of official

Handbuch... Wien 1889: p. 690; 1893 p. 591; Karl Josef Westritschnig, 2012.

Catholic doctrines. The church of St. Egidus was full of illegitimate kids who did not trouble much their own networks, while the monastic high schools still cared a lot about married life, probably even too much.

J. Stefan's father Aleš Stefan prospered a little bit. Therefore, he leased from his boss entrepreneur (Großnigbauer) Franz Puntschart a small store to sell flour and bread on Obere Burggasse no. 372. The site was in Stadt No. 372, on the former monastery of Ursulines (ehemaligen Ursulinenkloster), in the former Palais Ursenbeck today Burggasse no. 15 in Klagenfurt south of St. Egidus church. In St. Egidus Aleš finally married his good old sympathy Maria to enable the studies of their alleged natural son in the Benedictine Grammar school of Klagenfurt. As the family later lived together, it was probably not just a marriage of convenience needed for J. Stefan's high school studies although it sounds somewhat strange to marry the girl and design a joint household nine years after you fathered her son. Aleš (Alex) Stefan was mostly just selling his stuff and he himself was not involved in milling or baking business.

It was a Vormarch time of Metternich's industrialization which transformed old-fashion occupants into impoverished proletariat including J. Stefan's family members of carpenters, flour-dealers, tailors, tobacco fabric workers and housemaids. Just some gunsmiths kept their prosperous businesses around Borovlje if they worked out small editions of precise good-looking shotguns for wealthy hunters. With March revolution of 1848 the American settlements' dreams joined the chaos which buried old ways of life. The sexual freedom in suburbs was amazing while the clever guys were inventing all kinds of industrial tools but no distinct urgently needed sexual preservatives at all. The church of St. Egidus was full of illegitimate kids who did not care much in their own networks, while the monastic high schools still cared a lot, probably even too much.

J. Stefan's father Aleš Stefan prospered a little bit. Therefore, he leased from his boss entrepreneur (Großnigbauer) Franz Puntschart a small store to sell flour and bread on Obere Burggasse no. 372. The site was in Stadt No. 372, on the former monastery of Ursulines (ehemaligen

Ursulinenkloster), in the former Palais Ursenbeck today Burggasse no. 15 in Klagenfurt south of St. Egidus church. In St. Egidus Aleš finally married his good old sympathy Maria to enable the studies of their alleged natural son in the Benedictine Grammar school of Klagenfurt. As the family later lived together, it was probably not just a marriage of convenience needed for J. Stefan's high school studies although it sounds somewhat strange to marry the girl on joint household nine years after you fathered her son. Aleš (Alex) Stefan was mostly just selling the stuff and he himself was not involved in milling or baking business.

Alexius (Aleš) Stefan has denied the entry of his name in the baptismal book in the first place. The ecclesiastical attribution of paternity was not written at the first place. An official acknowledgment of the paternity of Alexius Stefan by the church took place only immediately before the accession of his son to the Benedictine Gymnasium: "In front of well known and signed witnessing respected named persons, Alexius Stephan has made himself known in our presence as the father of the child created with Maria Startinik, and explicitly demanded to be registered as such in the baptism book. The Expository St. Lorenzen in Klagenfurt on 3rd of October 1845. Simon Heber was an Expositor [Pastor] and Simon Tomantschger (Tomačker) was witness". Simon Tomantschger (Tomačker) was otherwise not known as the friend of Aleš or Maria's family.

Jožef Stefan seriously thought about joining the Benedictine Order where such Habsburgian scientists like Robida or Ányos Jedlik prospered. After his final examination (Matura) he dropped the idea of entering the any further education in Benedictine Order as he preferred the Viennese university. Probably J. Stefan liked girls too much to become a monk. He was influenced by some Benedictines at the Gymnasium as he daily walked the oldest Klagenfurt Allee leading from the Völkermarkter Vorstadt Höhe "Kumpfgasse" no. 43 over the railroad crossing into the Fortschnigg Allee. A ten-minute walk brings you to the junction with Lindenallee on Ebenthalerstrasse, which leads to the Baroque-style castle Ebenthal. The avenue was built from Ebenthal to Klagenfurt in the years 1706 to 1710. The teachers of the Normal Hauptschule of a high school recognized the skills of the young boy and supported his high school attendance. The parents married and so

paved the way for the smooth higher education at grammar school for the young Jožef Stefan. At that time, it was not possible for an illegitimate child to attend the Benedictine gymnasium. The Benedictine monks from St. Paul in Lavanttal have contracted to teach at the Klagenfurt Gymnasium since 1807. The Benedictine Fathers' task was to form their pupils' religious morals. The Prefect had to supervise this, with the respective district captains being responsible for it. The Benedictine Fathers taught in Klagenfurt Gymnasium after the dissolution of the Jesuit Gymnasium-Lyceum in 1773. In the period from 1807 to 1871 the Benedictine Fathers officially supervised that job.



Figure 22-36: Baptism of J. Stefan's father in 1805.

In the circle of the extended family of Josef Geiger, the bright boy Josef (Jožef) experienced his happy childhood together with the neighboring peasant children. The little Josef have been a favorite of all on the farm. The local chronicler, the director of city archive and librarian of Klagenfurt City hall (Magistrate) Carl Lebmacher (1876 Kirschentheuer in Rosental-1943 Klagenfurt) from Klagenfurt wrote in an article on the 100th birthday of Jožef Stefan: "In the circle of the numerous Geiger's family, the bright little boy, who at that time bore the surname of his mother, grew up diligently in the economy and [...] remained there until the age of nine, while he was the darling of all"²⁷⁷⁰.

At the time when he attended the normal Hauptschule in Klagenfurt, the boy Josef was increasingly burdened by his illegitimate birth. The kid still used the surname of his mother Startinik. When Josef was nine years old, his parents financially afforded to start a joint household in the

²⁷⁷⁰ Carl Lebmacher & editor Josef Höck, *Klagenfurt in alter Zeit: Historische Bilder aus dem Alltag in Kärnten*, Klagenfurt: Verlag des Geschichtsvereines für Kärnten, 1993.

Upper Burggasse in Klagenfurt. The boy literally bloomed through the marriage of his parents. His high school studies became possible! His way to school took only a few minutes by the Große Schulhausgasse in today's October 10th street. The parents supported their son according to their possibilities, especially later when Josef used to be a student of mathematics and physics at the University of Vienna.



Figure 22-37: Baptism of J. Stefan's mother in 1814.

The little boy Josef spent a lot of time in the surrounding fields and meadows of the rural "Franzl" - estate. During this time, his first interest in nature probably awakened, while his mother was engaged in the field work with a little help of her kid. The young boy began to work in agriculture himself. He learned all about the monotonous peasant work from personal experience. The southern St. Peter is located on the Ebenthaler - Allee and increasingly become an important suburb of the city of Klagenfurt. An orientation of this area towards the trivial school and pilgrimage church Maria Hilf in Ebenthal took place until the second half of the 19th century. The pilgrimage church in Ebenthal became an Exposit (Expositur) of the old Provost parish (Propsteipfarre) of Gurnitz. The parish - Expositur of Gurnitz with the church of Ebenthal, also includes the "Großnighof" in Limmersach with fourteen people living there. The "Franzlhof" on the eastern edge of the Katastralgemeinde St. Ruprecht accommodated those fourteen persons. The farmer Josef Geiger had a large family, whereby the servants with their children were also counted. The immense factory expansion in Limmersach brought a huge increase in the number of pupils at the elementary school in Ebenthal. The lower classed of organized Trivialschule in Ebenthal accommodated 64 students attending the first class and 80 students in the second class. In the restrictive and censored Metternich's Vormärz, on the eve of the bourgeois-

liberal revolution of 1848, the provincial town Klagenfurt administratively performed its inappropriately low status of a county seat. The Klagenfurt district consisted of 75 tax districts with a total of 532 cadastral districts.

Jožef Stefan's parents were of educationally disadvantaged rural origin. In the first half of the 19th century, the degree of literacy in rural areas was still low. A poor curriculum for their trivial education lessons often took place in the vicarages. The teaching at primary schools left much to be desired. It took the whole of the 19th century until the "epochal" compulsory education increasingly prevailed in the agricultural sector. The liberal State Elementary School Law (Reichsvolksschulgesetz) brought a decisive improvement for the education of the people in 1869, when it was already too late for then university professor J. Stefan. The "parish schools" finally transformed into modernized secularized curricula. Buildings for the higher-organized elementary schools in rural areas were created for the predominantly peasant population. The increasing influence of the Catholic - conservative politics after the liberal phase brought the Reichsvolksschulgesetz - novella for relief of country children's school attendance, whereby their compulsory school time was reduced. In the provincial capitals and in larger cities, public schools emerged as higher secondary schools. That school attendance relief worked far into the 20th century. The public schools were intended in large cities mainly for the students planning to join their handicraft and the trade. The farmer's sons of larger peasant farms often frequented the public schools in the city, usually with the help of their relatives and acquaintances who provided their food and accommodation during their school time. These bourgeois educational institutions were increasingly becoming feeder schools for the middle technical and commercial education system. The emerging vocational secondary schools were increasingly becoming a competitor to the high schools. The strong attendance of the grammar school was somewhat discouraged by the increasingly important vocational schools. Their similar real tuition and linguistic education was gaining more and more importance in the Gymnasium. In addition to the "humanistic" Gymnasium, the equally 8-year long studies at the Realgymnasium were established in dying Habsburg monarchy in 1908. In the first half of the

19th century, less than half of the school attendants in the country visited schools, with increasing tendency at their lower education organized in the one- and two-class trivial school. For the rural population, the elementary school in the country was usually still a compulsory school in the rectory. The usual compulsory school nearest to the birthplace of the boy Josef (Jožef) was then the trivial school in Ebenthal. The normal Hauptschule was increasingly developing into a feeder school for the Gymnasium. By attending this upscale compulsory school, Josef (Jožef) made his first steps towards his higher education at the Gymnasium and at a university. In the normal Hauptschule in Klagenfurt, the young Josef Startinik-Stefan seriously contacted the German language networks for his first time because his mother tongue was Slovenian. Up to Josef's age of nine his mother was a single parent of the young boy.

For Josef Startinik-Stefan, the Normal Secondary School was a basis for the humanistic Gymnasium of the Benedictines in Klagenfurt. After their marriage, the boy's parents best supported their son according to their possibilities. The talented and interested son was thereby enabled to progress at his educational and professional level. The finally officialised relationship of his parents provided a positive stimulus to the boy Josef. The illegitimate life circumstances in primary school were not rosy for the student Josef, not just because of the humiliating jokes of his classmates but also because of the standpoints of his teachers. The illegitimate son Josef Startinik had until the age of nine a big problem. The parents were not married, and they lived separately. The distance between the two parents' homes was minimal even on foot. The aspiring and interested boy thought that his matriculation access to the grammar school of the Benedictines in Klagenfurt was hardly possible. An official recognition of paternity was still missing, despite of a marriage of Josef's parents that took place in the city's main parish church of St. Egidus in Klagenfurt. This fact enabled various interpretations. The marriage of the parents, the enormous improvement of the private and professional living conditions and the relocation to Klagenfurt also enabled an educational and social ascent of Josef Startinik-Stefan. The young Josef (Jožef) used the better living and professional situation of his parents in Klagenfurt extremely well for his educational efforts. The interest in

education and diligence of the illegitimate boy coming from the Franzlscheune were increasing. Jožef Stefan developed into an important physics researcher and academic teacher of the Habsburg monarchy in the second half of the 19th century. A corresponding bourgeois relationship structure was missing to the young man, because of his educationally disadvantaged and low social origin. Jožef Stefan's father Alexius left his native "Stefanhube" in Lanzendorf in the then important tax district of Sonnegg in the Jaun Valley (Jauntal=Podjuna). The large control tax district Sonnegg had altogether 29 areas noted as cadastral communities (Katastralgemeinden) by the Franziszeischen cadastre of 1829. The owners of a farmhouse, which could take the considerable differences in size, then belonged to the rural middle class. Stefan's mother, a daughter of the country carpenter Gregor Startinick, came from the parish of Glainach im Rosental (Rož). The craftsmen in the country belonged mostly to the disowned class without real estates properties. In the 19th century, the artisans based in the periphery belonged more to the lower rural population. The craftsmen in the country usually had less education and training than those in the city. Since the Middle Ages the educational levels in the guilds have been fixed in the ranks of apprentice, journeyman and master. The rural structures of craftsmen usually did not have these three levels of education. The craftsmen from agricultural areas did not belong to guilds, as they did in the cities. In general, these craftsmen had a rather low reputation in the country. The possession of land and realities had a greater social significance in the country. His mother at the farm, and later also his father in town, created for the boy Josef a modest albeit still and limited possibilities of a suitable framework, which allowed a higher education for the young Josef. The ambitious and education-hungry adolescents were expected to get their higher education at the Gymnasium at the Benedictines in Klagenfurt. The guys from four-year compulsory school could enter the upper secondary school, which formed a good basis for a high school education. The musically, technically and mathematically gifted adolescent Josef entered the Gymnasium in Klagenfurt at his age of ten. His first education boosted immediately after the liberal-bourgeois revolution advanced through the Stadion's imposed March Constitution in 1849-1851. The higher schools and secondary schools were reorganized and thus also

modernized. The Gymnasium had eight classes-years with the four-year lower and four-year upper grades, which remained still the basic structure today. The normal secondary schools were developing into important feeder schools of the "higher" grammar schools. Before the revolution of 1848, the grammar schools together with the Lyceums were still seen as "scholarly schools", therefore preparing guys for their studies at universities.

Did Geiger provide some help for Josef (Jožef)? Later in 20th century Geiger guy was not very happy with J. Stefan's memorial plate put in front of his house. It was probably hard for Geiger to confess that the poor kid was far the best of them all, with his bosses also included. The brand-new bride Maria and the product of her past love J. Stefan moved to Josef's father new home at least upon his matriculating in Grammar school. The kid Josef had to carry heavy sacks and bags full of flour which forever pushed his right shoulder somewhat higher above his left one. J. Stefan also praised beans a lot because they were a rare specialty in his juvenile Klagenfurt home.²⁷⁷¹

Later, the family of J. Stefan moved to the neighboring Klagenfurt Stadt no. 370 which provided some more luxury for a small family of three members which had no ambition of multiplying for the time being. Aleš (Alexius) Stefan's son Josef worked diligently during the school-free time in the flour and bread business, as he carried those heavy flour sacks. At the beginning of the 19th century, there were eight mills on the Glan river in what is today a part of a city Klagenfurt. At that time, the flour mills were an important trade situated on the banks of rivers. No other equivalent energy suppliers were at hand except the less advantageous windmills with steam engines just slowly penetrating. The wheels of water mills on Glan river became the basis of Stefan's later brilliant hydrodynamic analogies. The Glan River has a low flow velocity in Limmersach in area of the Großnigmühle which stimulated J. Stefan's hydrodynamic interests. As a result, the Glan river in this area was very slow and swampy, therefore it was regulated accordingly by Franz Puntschart Junior in 1868. The "Großnighof in Limersach (Limmersach, Limarče)" in the Katastralgemeinde St. Peter - Ebenthal was owned by the large-scale farmer and miller Franz

Puntschart. He owned his farms (Grundparzellen) mainly in the cadaster municipality (Katastralgemeinden) of St. Peter - Ebenthal, also in St. Ruprecht, in St. Martin and in Radsberg. In the Katastralgemeinde St. Peter - Ebenthal are the villages Harbach with the castle Harbach by Klagenfurt- Ölgemälde owned by Markus Pernhart (1824-1981), Ladinach (Ladine), Limersach (Limmersach, Limarče) and Rosenegg. Aleš (Alexius) Stefan worked as a miller's assistant at the "Großnighof", where a long-standing large flour mill already milled south-east of the town of Limmersach (Limarče). Jožef Stefan's father lived at the Großnighof in Limersach (Limmersach, Limarče). The Großnighof is only about one kilometer away from the birthplace of Jožef Stefan, which is located on the Ebenthaler Lindenallee.

In Limmersach the [property] owner and miller was Franz Georg Puntschart. His son, born in 1816, had the same name. He took over the local mill as early as 1837, soon after J. Stefan's birth. After traveling through Bohemia and Germany, Franz Georg Puntschart (1816–1872) began with the production of compressed yeast in 1840 and the mill became an 'art mill' in 1853. In 1868 he built a new plant and regulated the Glan river. The area was once owned by Viktring Abbey. Already the old Urbar as a list of the manorial taxes noted a mill on the Glan river in its narration of document.



Figure 22-38: Marriage of J. Stefan's parents in 1844.

The technology of "pressed yeast production" in "Limersach (Limmersach, Limarče)" becomes more and more obsolete over time. Soon after Jožef Stefan passed away, the owners of the factory facilities Franz Puntschart & Söhne sold these objects to the Jewish industrial magnate Sigmund Fischl (Siegmond Fischel, * 1847 Myslkovice (Miskowitz) in Tabor district of south Bohemia; † 1905 Prague) from the industrialized country of Bohemia on January 26, 1894. The

²⁷⁷¹ Čermelj 1976 10-11.

funny old times of the small family businesses gave place to the big factories.

For one reason or another, only on 25 August 1844 J. Stefan's parents were married in the church of St. Egidus in Klagenfurt while they lived at Stadt no. 372. The illiterate marriage witnesses were Johann Urbantschitsch (Urbančič) as a colleague of Aleš Stefan in flour merchant business (Mehlhandler) and Johann Haberl as Büchsenmacher (gunsmith) from Ferlach where many branches of J. Stefan's mother's side originated. There was also note about "Franz Sal district solicited signer named for incentives crosses of illiterates (Franz Sal Kreis (=Salkreis) Erz als erbeten (=erbethen): Namensfertiger in Zungen des ein einhändigen Kreuz Inzensen)". The celebrant of the marriage ceremony was the priest cooperator Franzsel Lehrbeng. The happy bride was noted without her old job as Maria Startijek born in Glainach by the already deceased Catholic master carpenter and his still living widow (zu Glainach Gebürtig, ehelich Erzeugten Tochter der schon Verstorbenes Gregor Startijek gewes: Zimmerman Meister im der Pfarre Gleinach und seiner nach lebendige Ehrgattin Apolonia geborenen Olippin beide Katholisch. Geborenen um 3 August 1814). J. Stefan's maternal grandfather was therefore buried long ago, but his maternal grandmother still lived. J. Stefan's father was noted as flour merchant in the city (in Diensten Staat Pfarrers Bezirke). Aleš (Alex) was a legitimate son of his deceased farming father and still living Catholic widow (ehrllich Erzeugten Sohn des Johann Stephan Gmons: Bauern zu Lanzendorf in Bezirke Souniggischen Inlichen, und Seiner noch lieb und en Ehrengattin Wittibe(th). Beide Katholisch. Geboren am 16 July 1805). J. Stefan's paternal grandmother also still lived, and the polite J. Stefan became the favourite of his both grandmothers.

A year after that great marriage, J. Stefan was legalized in the Catholic church of St. Egidus at Pfarrhofgasse 4 in Klagenfurt on 3rd October 1845. It was high time because boy could have huge problems in Benedictine Grammar school of Klagenfurt as the illegitimate child.

J. Stefan finished his three-years Normal school in Klagenfurt as the illegitimate child, but he was already legitimized few days after he began his Grammar school studies under the schoolmaster

the medicine doctor Johann Burger who also served as Matija Ahacel's descendant on the chair of Natural history and agriculture in 1845/46. J. Stefan loved Natural History and collected the botanical names in Slovenian language which amazed his teacher Janežič.

Why did J. Stefan's parents wait so long, at least nine years from their supposed love affair until their official marriage? The exposit priest Mathäus Tschuden (Mathias Čuden, Oskudek) certainly wrote father's name long after the baptism of J. Stefan and priest or his replacement later noted the fact of marriage and legitimization below with nearly the same ink. Much later with a plain pencil the data of J. Stefan's death were added on the right corner of the note.

J. Stefan's Slovenian Klagenfurt quickly became the cradle of Slovenian nationalism. Through the nationalism, languages were increasingly occupied by political ideology. The language-oriented nationalism becomes increasingly meaningful after the liberal revolution of 1848. The mother of Jožef Stefan came from Rosental (Rož) and there she spoke a corresponding Slovenian dialect. The father of Jožef Stefan came from Jauntal (Podjuna) and thus used the most common kind of local Slovenian dialect. In the Klagenfurt area the Rosentaler (Rož) variant of Slovenian dialect was spoken.

The Zedinjena Slovenia (United Slovenia) movement was formulated by the chaplain of Klagenfurt Cathedral the Carinthia native Matija Majar (1809 Wittenig (Vitenče) in Zilja (Ziljska Dolina, Gail valley)-1892 Prague) on 17 March 1848. Majar studied in Klagenfurt Lyceum under the prevailing influence of Anton Martin Slomšek who served as the spiritual director of seminarians at Klagenfurt from 1829 until 1838.

The Pan-Slavic priest Majar decisively influenced Stefan's romantic national feelings while the Viennese professor Fran Miklošič was much more coldblooded scientist like Kopitar before Miklošič.²⁷⁷² In autumn of 1848 by the order of minister, Anton Janežič (1828-1869) began to teach Slovenian language in Klagenfurt Grammar school, although without any salary. Next year in 1849/50 Janežič's Slovenian Language lectures in three classes for Slovenians were obligatory and

²⁷⁷² Čermelj 1976 34.

two classes were launched for Germans. The Slovenian student J. Stefan was among the best already in his first Slovenian language class which joined the students of 2nd, 3rd and 4th grades. There were a lot of problems with textbooks needed for Slovenian language lectures for higher grades. The officially declared Slovenian students were in minority, but in Stefan final 8th Matura class there were as much as eight Slovenes of altogether nineteen students in 1852/53. Still lower proportion of Slovenian students studied in Klagenfurt real school although the Slovenians had at least 1/3 of inhabitants in the area, but many preferred not to declare themselves as the Slovenians anymore because of their forced Germanization. Andreas Einspieler (Anfrej, 1812-1888) from Suetschach in Rosental (Sveče in Rož) attended the Gymnasium and the Lyceum in Klagenfurt. Einspieler was ordained a priest and taught catechism with religion at the Klagenfurt Gymnasium of the Benedictines. He studied for a teaching degree at the University of Vienna. Andrej Einspieler taught Slovene at secondary schools. Einspieler advocated a brotherly treatment of the Carinthia-based German and Slovenian "tongues". In the revolutionary period of 1848 Einspieler became an advocate of the equal rights of the Slovene language in the school, in the court and in the administration. Stefan published his writings in Einspieler's journal Šolski Prijatelj (School Friend).

The versatile and diligent student Josef Startinik-Stefan was admitted to the Normal-Hauptschule which was a higher elementary school. The Normal-Hauptschule developed as a basis for the educational advancement focused through the Benedictine Gymnasium in Klagenfurt. The footpath of the boy to the normal Hauptschule in the small school lane of today's Kaufmannsgasse was about 3.5 kilometers long. The way to school leads from J. Startinik-Stefan's place of residence in the south of the village of St. Peter of today Ebentalerstraße on the former Linden tree avenue through the Völkermarkter suburb to the corresponding gate, through the Burggasse to the normal secondary school in the small school lane. The parents had a low educational status as most had in rural areas of that era. The father and mother of boy Josef did neither know how to read nor to write. The parents best promoted the talents and interests of the young kid according to their possibilities. The good relationship between the

son and his parents was still maintained when Jožef Stefan was already a successful researcher and outstanding professor of physics at the University of Vienna. Stefan became a modest and withdrawn person and a university teacher. He usually visited his parents in Klagenfurt for two months during the summer holidays. This was a kind of thanking of the son to his gracious parents who financially supported their son according to their modest possibilities not only as a high school student but also as a student in Vienna. The general state scholarships were introduced in Austria only in the 1960s.

One year before entering the Klagenfurt Gymnasium, Jožef Stefan was fortunate in his personal circumstances. In 1844, his parents married, and a year later, his father recognized his paternity in the parish of St. Egidius just before J. Stefan entered the grammar school. The mother Maria moved from the Franzlkeusche in the south of the village of St. Peter to the city of Klagenfurt. The father Aleš was already working in the leased flour and bread shop in the Upper Burggasse. The long service in "Limersach (Limmersach, Limarče)" brought to the miller mate Aleš some luck by the gratitude of farmer and mill owner Franz Puntchart. Alexius (Aleš) Stefan took over the leased flour and bread business from the big farmer Puntchart. The miller's assistant Alexius Stefan leased the flour and bread shop in Burggasse in Klagenfurt from his employer. Alexius Stefan used to be a departing farmer's son of the "Stefanhube in Lanzendorf" in the cadastral town of Grabelsdorf, the large control district Sonnegg in Jauntal (Podjuna). The lease of the flour and bread shop in the Upper Burggasse in Klagenfurt meant a socially and financially better position for the family of Stefan which now lived together. In the initial premises of the Ursuline Monastery, a family of three now lived under one roof. The son Josef was spared of his previous long walk from the place of residence in southern St. Peter on the Ebenthaler Allee to the normal secondary school in Klagenfurt. J. Stefan's birthplace was a servant building on the farm of Joseph Geiger. The birthplace of Jožef Stefan is located on the eastern edge of the large area Katastralgemeinde St. Ruprecht. Due to his new place of residence in the upper Burggasse, the high school of the Benedictines in the large school lane was only a few minutes away from the new Josef's home in Burggasse. The marriage of the parents

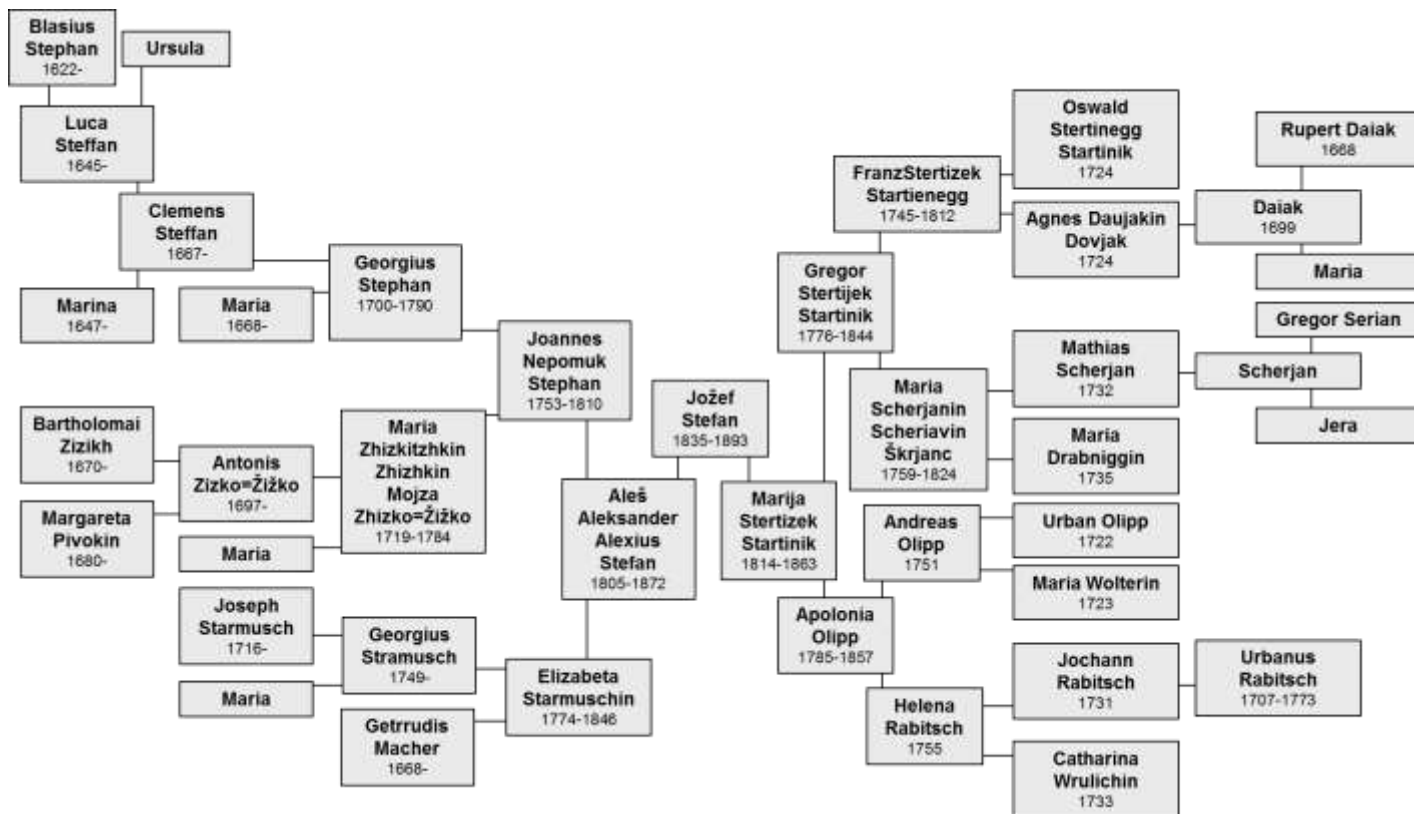

Figure 22-39: Stefan's ancestors on all branches



Figure 22-40: Funeral of J. Stefan's mother in 1863.

made it easier for Jožef Stefan to enter the Gymnasium under the direction of the Benedictines. The financial situation of the parents and the local situation due to the move to Klagenfurt have an extremely positive effect on Jožef Stefan in every respect. This may be one reason for Jožef Stefan's very kind and good personal relationship with his parents. Jožef Stefan was extremely grateful that the family's living conditions have developed so positively for him. He always visited his parents during the summer holidays in their lifetimes. He visited them even when he was already a recognized scholar and researcher at the University of the Imperial City of Vienna. Jožef Stefan's mother Maria Stefan died of

apoplexy at the age of 48 in her home at Klagenfurt Stadt 370 as a wife of towns flour merchant on October 23, 1863. She was buried two days later at St. Egidus by the city priest Max Wallner.²⁷⁷³ Just before she passed away in 1863 Stefan was appointed Full Professor of Mathematical Physics at the University of Vienna. Jožef Stefan's father Alexius Stefan lived until December 8, 1872. A decade after his mother, J. Stefan's father died 67 years old in his home of Klagenfurt Stadt 370 as the city flour merchant. He died of pneumonia noted as Lung infection (Lungenentzündung). He was buried two days after he passed away at St. Egidus church.²⁷⁷⁴ J. Stefan's parents were illiterate, but he tried to teach his mother probably to enable her to read his letters which he frequently mailed to her from Vienna.

In Klagenfurt J. Stefan joined the local Slovenian male singing choir as the first singer of professor Robida's choir and later singed with his fellow Slovenian students in Vienna. The versatile Stefan was also dedicated to music and choral singing. In his 8th Class of the Gymnasium Stefan was a first

²⁷⁷³ Schlagfluss, noted by K15_072-1, page 141, Sterbebuch XV.

²⁷⁷⁴ Sterbebuch XVI; K15_073-1, page 255.

singer of the Klagenfurt singer choir. He became a student member and choirmaster of the "Slovenian Choral Society" in Vienna. J. Stefan coedited their Viennese local journal *Slavia* and joined the society *Mormonia*.²⁷⁷⁵ Stefan also wrote in southern Bavarian dialect which is the German Carinthia dialect. Stefan later gave his entire unpublished literary material to the folk song composer Thomas Koschat (1845-1914) from Viktring (Vetrinj) near Klagenfurt who worked and lived in Vienna. Almost a century later, Viktring (Vetrinj) became the evil destiny for Nazi collaborators who tried in vain to surrender to the Anglo-American allies.

Stefan learned a lot of languages including Czech, Russian, Croatian, French and English. He loved to return from Vienna to his holidays into Carinthia home to his loving parents and he liked to hike around to Ferlach (Borovlje), Rosental (Rož), Rutarch (Rute), Bodental (Poden), Judenburg, Alps, Hüttenberg (Getenberg), Knappenberg, Lölling, Wolfsberg (Volšperk) and Völkermark (Velikovec) with his fellow Carinthia native Viennese and Graz students Gratzner, Gobanz, Martinz, Schücktanzen and Karl von Jaeger (Jäger, 1936 Carinthia-1920 Graz) who studied law, politics and philosophy in Graz for his Ph.D. in 1861 and served in different ministerial administrations after 1869. Stefan also lectured for his fellow student privately on Leidenfrost's effect in 1857 and on diffusion and on Dulong-Petit's law in 1858.²⁷⁷⁶ Dulong-Petit's law became one of the major focuses of Stefan-Boltzmann statistical kinetic atomism designed against Simon Šubic's opposition.



Figure 22-41: Funeral of J. Stefan's father in 1872.

The only Stefan school trouble has escalated in the first semester of his 6th grade in winter 1850 of

1850/51 school year. He was noted in catalogue as the guy "unavailable for good-natured reminders".²⁷⁷⁷ The professor who made that trouble was not noted but he might be the professor of physics Robida whose Slovenian and other publications Stefan never mentioned even in his private diary where he praised Vertovec and other Slovenian writers.

The Benedictine Johann Chrysostomus Sepper taught mathematics in J. Stefan's class by Močnik's textbooks.²⁷⁷⁸ Močnik became in many ways Stefan's model: both knew fairly well that there is no way to the top Habsburgian positions for Slovenian nationalists which forced Stefan to learn his life lessons very well and to abandon his early ambitions in Slovenian poetry.

In 1850/51, Robida taught physics and chemistry by Baumgartner's textbook in Stefan's sixth grade without any ideas about Stefan's future chair of physics at the University of Vienna and his leading roles at the Academy of Sciences in Vienna. Probably they had an argument in the winter of 1850. Robida was angry enough to have his frustration noted in the official reports and Stefan never forgot that humiliation. In his final class, Stefan attended his religious instructions 2 hours per week in winter semester and 2 hours per week in summer semester. He had 6/5 hours of Latin language a week, 4/5 hours of Greek language a week, German language 3/3 hours a week, Slovenian language 2/0 hours a week, history and geography 2/3 hours a week, mathematics 3/0 hours a week, natural history 4/1 hours a week, physics 0/3 hours per week and philosophical propaedeutic 0/2 hours a week. Stefan listened to his lecturers 26/24 hours per week in his final Grammar school year which was somewhat less than the students enjoy nowadays.

At the end of his 7th "Gymnasialklasse" Jožef Stefan received as his first prize, the physics textbook authored by Wilhelm Eisenlohr (1799-1872). Eisenlohr was an important professor of physics and mathematics at the Karlsruhe Polytechnic Institute which was an emerging higher technical education category in the 19th century named and designed by Parisian model. In this textbook of physics Eisenlohr also published his significant research results in the field of optics.

²⁷⁷⁵ Čermelj 1976 23.

²⁷⁷⁶ Ivan Šubic 1902 83; Čermelj 1976 28, 35.

²⁷⁷⁷ Čermelj 1976 18.

²⁷⁷⁸ Čermelj 1976, 20.



Figure 22-42: Baptism of J. Stefan's paternal grandmother Elisabeth in 1774.

After the Maturitätsprüfung, the high school professors awarded Stefan the complete dictionary of the mythology of all peoples of Karl May's (*1942= model professor of physics transformed into populariser of sciences Carl Gottfried Wilhelm Vollmer (Pseudonyms W. F. A. Zimmermann by his wife's maiden name, W. C. A. Zimmermann, C. Morvell, * 1797/98 Torún (Thorn) in north central Poland; † 1864 Stuttgart or Berlin). It was published with the editor Heinrich Kern's preface on 1091 pages with 415 concluding illustrations in Stuttgart in 1851. Stefan's teachers added the note: "To the high school graduate Jožef Stefan as a memory of his studies at k. k. Gymnasium in Klagenfurt from the faculty. Johann Burger Director, Klagenfurt, the 21st of September 1853." Vollmer visited Austria and Bohemia in 1827 and Stefan's teachers certainly wished to promulgate Stefan's passions for long distance travels by such readings, but Stefan disliked such traveling anyway.

22.2.4 Provincial Genius in Metropolis

Stefan soon recognized Vienna as the final place of his life ambitions. An unhealthy city full of Viennese movements in contrast to his domestic mountains, but those movements were necessary for the promotion of atomic movements on Stefan's Parnassus. Stefan was a poor country boy and his hard labour, talent and obedience were his only tools for a distinguished job.

During his High School studies Stefan used Experimentalphysik of August Kunzek who became Stefan's teacher at university as

Lehrkanzel-Vorstand für Physik from 1850 to 1865. Stefan proved to be more papal than the popes of Viennese atomistic kinetics ether, Cauchy's protegee Ettingshausen and Ettingshausen's son-in-law Wilhelm Josef Grailich (1829 Bratislava-13. 9. 1859 Vienna). Grailich was a son of the professor of philology and mastered eight languages after his juvenile journeys through Hungary and Trieste. In 1857, he married the daughter of his boss Caroline Ettingshausen (1835-1913). In that year 1857 Stefan began to study the oscillations of waterdrops which Johann Gottlob Leidenfrost (* 1715; † 1794) discovered in 1756²⁷⁷⁹ Almost two decades later, on 10. 4. 1875 August Toepler (* 1836; † 1912) lectured on them while focusing capillarity for Styrian Natural history society in Graz. Toepler strongly lighted the effect with the inflamed quartz of Scottish engineer Thomas Drummond (Drummond, * 1797; † 1840). Toepler (Töpler) used the system of mirrors to project the pictures for the great amusements of attenders. Toepler shew the curved surfaces of water or mercury with the apparatus developed for those occasions by Louis Jules Dubosq (* 1817; † 1886). Toepler also used the shattered limestone of a new type for a good illumination of experiments in the classroom with Oxyhydrogen gas.²⁷⁸⁰



Figure 22-43: Marriage of J. Stefan's paternal grandparents in 1792.

22.2.5 Koller Enabled for Stefan's Academic Success

Stefan's senior Viennese collaborator Grailich soon intervened in the very middle of Stefan's native Slovenian milieu. The Czech German Mitteis presented an interesting purchase of his physical cabinet of the gymnasium in Ljubljana to the Carniolan Museum Society. Mitteis popularized his physical cabinet, which was also

²⁷⁷⁹ Ivan Šubic 1902 83.

²⁷⁸⁰ Toepler, 1875, L-LX.

the purpose of later (primary) school exhibitions. On 11 October 1851 he was appointed as teacher of mathematics and physics and he began to teach at the Viennese Theresian Academy. Between 1862-1865 Mitteis was a member of the city council of the Ljubljana municipality. He was also a member of the Philharmonic Society and the Museum Society, and for thirteen years (1853-1866) he taught physics and occasionally mathematics in Ljubljana. At that time, members of the Philharmonic Society were arguing about Slovene or German singing. During this time, Mitteis dealt with meteorology and seismology. He investigated electromagnetic phenomena and their history. In 1856, he presented four lectures on electricity in front of the Carniolan Museum Society, among which three focused the historical data.

During his stay in Ljubljana, Mitteis actively participated in most meetings of the Museum Society. In 1856, he devoted his lectures to the history of electricity, which he published in the same year in the Yearly of the Ljubljana Gymnasium. Even in later lectures, Mitteis dealt with electricity, but his approach was no longer so distinctly historical, certainly under the influence of Grailich's critics. In 1858 Mitteis lectured on earthquakes and published on them in 1858 and 1862 in the Reports of the Museum Society. Two thirds of his lectures in front of the Museum Society were illustrated by experiments between 1856 and 1859. That is why the museum itself had to have some physical apparatus, although Mitteis brought most of the supplies from his physics cabinet of the Ljubljana Gymnasium. Lectures at the museum were often one of the first presentations of his new physical equipment purchased in gymnasium. All important and interesting instruments which he acquired in 1858/59 for the Gymnasium Physical Cabinet were presented to the Museum Society in the same year. He was a gifted experimenter, and among the members of the Museum Society he had enough educated listeners who were interested in his work.

On May 2, 1856, Mitteis had a lecture on the history of lightning in front of the Carniola Museum Society. He explained to listeners that, at southwestern border of Carniola in today's northern Italy, Franklin's points and conducting wires were used as lightning rods hundred years ago. This was proved by Mitteis with the content

of the letter which G.F. Bianchini sent to Parisian academy on 16 December 1758. Mitteis found the data about those events in Lyceum library of Ljubljana.



Figure 22-44: Funeral of J. Stefan's paternal grandmother Elisabeth in 1846 which he attended as eleven years old recently legitimized kid.

Bianchini carried out experiments in the Devin castle of Carniola near Udine (Videm). At first, he used a military halberd. Otherwise, the observation of the lightning in the town of Devin already had a nice tradition, since it was already described by the monk P. Imperati in 1602.

Mitteis' lecture aroused considerable attention, as his listeners were also highly educated people, including a member of the museum society the director of lower real school in Ljubljana Mihael Peternel, a former student and assistant to professor J. K. Kersnik who was the first professor of chemistry in Ljubljana. In a paper delivered after Mitteis lecture, Peternel explained few additional facts about the connection between electrical phenomena in lightning and meteorology.

In 1856, Mitteis' interest in the history of electricity quickly aroused with the discovery of rich material on these issues in the Lyceum Library. The modern NUK keeps under the reference code 7078 two Bianchini's letters mailed to the Parisian Academy and printed in Venice in 1754. The first of these describes dr. Giovanni Fortunato Bianchini's atmospheric electricity in the town of Devin in western Carniola. These letters are also found in Kalister's and Čop's List of Lyceum Books from 1826-1832. However, the census does not contain a letter cited by Mitteis

dated on 16 December 1758. Nevertheless, it is very probable that Mitteis also found that document in the Lyceum Library of Ljubljana renamed into Academic library, although it is no longer there today.

From here, we can rightly conclude that Mitteis also wrote his paper (1856) about the Nollet-Franklin dispute after a detailed study of the subject matter of that subject. A large part of these writings came to the Lyceum Library by the purchase of books from the legacy of Žiga Zois between 1809-1815. From the inventory of the Zois' Library at the time of his death, it is evident that Zois acquired mostly French books that advocated Nollet's ideas and criticized Franklin. Among these works are the books of Nollet himself and the Parisian French translation of Priestley which favored Nollet.

Grailich congratulated Mitteis for his picking up the interesting stuff related to Franklin-Nollet's quarrels, but Grailich stated that a guy must be careful while discussing the history of physics. Grailich between the lines missed Mitteis' taking sides in Franklin-Nollet's quarrel. Mitteis behaved like the neutral historian of physics while Grailich, who was more powerful in his Viennese networks, declared that the history had to serve a modern politics in physics. Stefan was silent just like during Grailich's critiques of Robida, but Stefan certainly previously discussed both problems with Grailich in their labs to make Stefan even more papal as he liked to declare later to his naughty students' invitations: "You see, we the physicists, we do not dance".

22.2.6 *Stefan's Collaborator Grailich against Robida and Mitteis' Electromagnetism*

On 17. 1. 1850, the Viennese institute for physics was established in the time of the first uses of cathode-ray tubes. Its first head became the mining councillor Doppler. He was a professor at the Viennese Polytechnic, together with the former Ljubljana mathematician Karl Schulz von Strassnitzki. Doppler became famous in Prague in 1842 by exploring the changing frequency of the emitted light of stars due to their movement in a vacuum. Doppler's claim was ok, but his astronomical examples were false which soon ruined his Viennese prestige in favour of

Ettingshausen's variant of Doppler's kinetic atomistic while only the dissident Mach's group continued with Doppler's Prague research of waves. Almost all the other Habsburgian erudite opted for Stefan's atomic kinetics.



Figure 22-45: Stefan and his collaborators with experimental tools near their old lab in Erdbergstraße in 1873-1876 (Stefan Archive Wien 106_I_3988 Mitglieder des Physikalischen Instituts in der Erdbergstraße 1873-1876).

The director of the Physics Institute, Doppler was appointed as a full professor at the University of Vienna. His work began at the Institute on April 1st, 1850, at the premises of today's Academy of Sciences. Until 1875, the Erdberg Institute was at Erdbergstrasse No. 15, in the third Viennese district (Bezirk) Landstraße. In 1875 Stefan moved the Institute to its more suitable location Türkenstrasse no. 3 in IX Stadtbezirk of Vienna called Alsergrund. It seems that something unhealthy was there at Erdberg, maybe connected with mercury in barometers, thermometers and vacuum pumps or other experimental apparatus, as Grailich died extremely young, Doppler hardly reached his fiftieth year, Stefan died before he was sixty, his student Boltzmann hanged himself at sixty-two, Baumgartner was soon unable to teach because of his neck disease in 1833, while Ettingshausen (* 1796; † 1878) went gravely ill in his early sixties although he lived to be eighty-two.

In the spring of 1852 after Doppler's forced dismissal-disease, the management of the Institute was taken over by Ettingshausen, the former professor of engineering in the Viennese Polytechnic. The court councilor Ettingshausen had an unusually many private docents compared to the universities in Germany. The state did not

interfere with his attitude to postgraduates; he directed his docents into his own research, of course, primarily dedicated to confirming the assumptions about the atomic structure of matter. He bought vacuum tubes very early. He noticed that the color of the vacuum in the tubes was affected by the spectrum of the gas contained. In the narrower parts of the vacuum tube a disconnected illumination was observed, and in the wider parts of the tube there were nice layers. He therefore commissioned his assistant of Physics Institute Edmund Reitlinger (1830 Pest-1882) and the elev  in Physics Institute Stefan's few months younger colleague Luka  erjav to investigate the spectra in vacuum tubes depending on the type of gas filling and the thickness of the vacuum tube.²⁷⁸¹ They relied on the physician turned spectroscopist expert Franois Auguste Morren's (1804 Bordeaux-1870 Marseille) letter sent from Marseilles to Cauchy's Jesuitical protegee Franois Napoleon Marie Moigno (* 1804; † 1884). Reitlinger began his studies in Heidelberg and Gottingen with Wilhelm Eduard Weber (1804-1891) who soon proved to be the grave enemy of Ettingshausen-Maxwell-Helmholtz's mainstream. Already on 24. 4. 1856 J. Stefan studied the works of W. Weber and Gauss a lot and even Boltzmann noted W. Weber,²⁷⁸² but Weber's electromagnetism was probably too close to Robida's undulatory theory for later Stefan's taste. Stefan even tried to study Cauchy's ideas very early and Stefan used books he was awarded with for his excellent marks in Grammar School.

Reitlinger received his doctorate by the institute of Ettingshausen in 1858, and in the following year, together with Stefan, he became an assistant professor at the Institute. For many years Reitlinger edited the supplement *Natur- und V lkerkunde* of *Neuen Freien Presse* where many Jewish correspondents wrote including the feuilleton of the father of Zionism Theodor Herzl. Reitlinger wrote an extensive biography of Josef Ressel in 1863, authored the history of Telegraphy in S.  ubic's sense in 1866, and published another extensive biography of Kepler in 1868. In 1866, Reitlinger became the professor of Viennese Polytechnic together with former Ljubljana professor J. Finger and Victor Pierre who researched fluorescence in 1866. In 1874, Reitlinger dedicated his anthology of his popular

history of science articles *Freie blicke: Popul r wissenschaftliche Aufs tze* to the Berliner climatologist Heinrich Wilhelm Dove (1803-1879). Later in 1905 Boltzmann also published an anthology of his popular scientific publications.

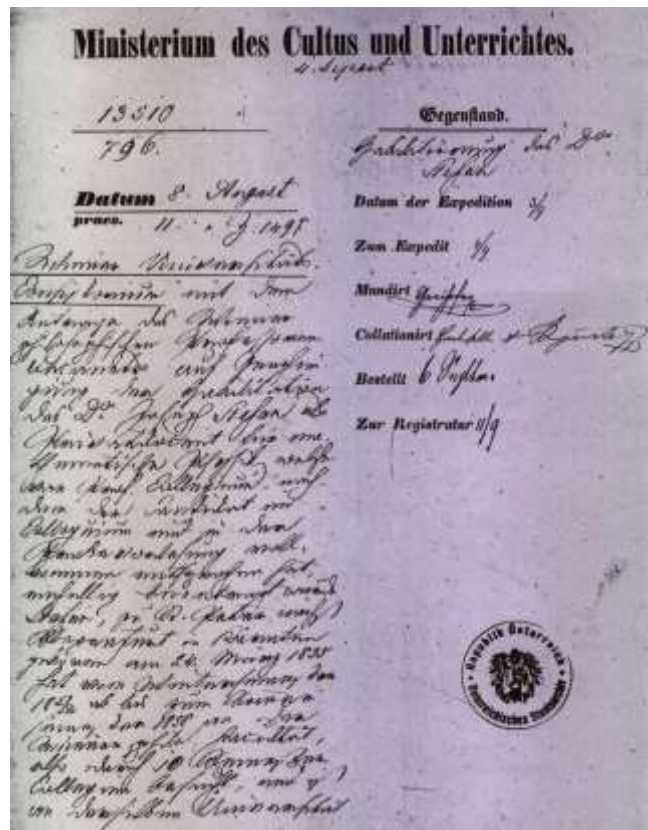

Figure 22-46: The title-page of Stefan's application for habilitation at the University of Vienna was submitted in September-October 1858 (Documents, September 3, 1858).

Luka  erjav's publication of 1862 was a kind of his graduate thesis as he left Ettingshausen's institute soon afterwards while Stefan became the associate professor in 1863. In 1863-1878, Luka  erjav (Lucas Zerjau, Sherjou * 1836 Bloke or  ešnjice in Carniola) served under the deputy director the former Ljubljana professor Heinrich Mitteis as the prefect of Theresianum academy in Vienna. Then he prematurely retired and still lived in 1880. Luka's relative could have been Anton  erjav who served in finance department of Sisak in Croatia in 1866.²⁷⁸³

Stefan served for one semester as "Z gling (elev )" at the Viennese Physics Institute, where he showed "extraordinary talent". Between August 8, 1858,

²⁷⁸¹ Reitlinger,  erjav, 1862, 352-361.

²⁷⁸² Ivan  ubic 1902, 72, 76.

²⁷⁸³ *Hof- und Staats-Handbuch des Kaiserthumes  sterreich* 1866, p. 648; 1868, p. 257; Gemzell-Flischbach, Montesole, 1880, p. 153.

and September 24, 1858, Stefan's Habilitation was conducted for his job of a private assistant professor of mathematical physics, but he still had to lecture in nearby high school to earn for living as he joked that everybody wanted to work with him while nobody wanted to eat with him. Like Helmholtz earlier, Stefan was first supported by the Viennese professors of medicine who were not happy with the liberal lectures of physics for the students of medicine in the class of E. Mach and Mach's successor Reitlinger. Stefan received the decisive support from the Viennese professors of medicine and physiology in their last great attack into physics' networks. Those physicians who finally decided to eat with Stefan after they've heard him lecturing were Helmholtz's (1821-1894) collaborators the naturalist Ernst Wilhelm Ritter von Brücke (1819 Berlin-1892 Vienna) appointed in Viennese university as professor of physiology and microscopical anatomy in 1849, and Carl Friedrich Wilhelm Ludwig (1816 Witzhausen 20 km south of Göttingen-1895 Leipzig) who taught in Marburg where he joined the liberal spring of nation networks as the editor of *Neuen Verfassungsfreundes*. In 1855 Ludwig became the full professor of physiology and zoology in Viennese Josephinum school for military surgeons (Medizinisch-Chirurgische Militärakademie) and taught there until 1865. Ludwig and Stefan both had their surnames spelled like Christian names which sounded funny and contributed to their mutual friendship. Ludwig and Brücke were both from Germany and not from Habsburgian lands which made them more cosmopolite and less vulnerable for nationalistic feelings against Slavic folks of Stefan's sort. On his side, Stefan was willing to put aside his own Slovenian emotions in exchange for a great academic career.

Brücke's archenemy was the Viennese professor the supporter of romantic physiological vitalism Josef Hyrtl (1810 Eisenstadt (Železno) in Burgenland-1894 Viennese suburb) who suffered total losses of his personal belongings during the Viennese spring of nation in the course of March 1848 revolution and opposed Epicurus or Lucretius' materialistic atomism. In October 1857, Ludwig heard Stefan's talk at the Viennese academy entitled Observations on the Absorption of Gases and enabled Stefan to use Ludwig's lab while Ludwig also supported his Marburg student Adolf Fick's (1829 Kassel-1901 Blankenberge in

Flemish Belgium) research of diffusion.²⁷⁸⁴ Stefan was still unable to conduct his experiments according to his own ideas in Ludwig's lab, but it was a great step forward for a young provincial guy like Stefan whose Carinthian German dialect never allowed him to become a real Viennese freak.

With such support of the liberal Viennese professors of medicine, Stefan just could not fail on his way to the top. In 1860, Stefan became a corresponding member of the Imperial Academy of Sciences in Vienna because Brücke lobbied for him. After Grailich suddenly passed away, Stefan got his own five minutes. Brücke recommended Stefan to the counselor in the ministry for Education and Religion the Benedictine Marian Koller who personally attended the lecture in Stefan's classroom.²⁷⁸⁵ As a native Carniolan, Koller had some special sympathies for Stefan's Slovenian origins. Koller worked together with Johann Kleemann, later baron Eduard Tomaschek, the counsellor Johann von Fontana and the cryptogamist Ludwig Samuel Joseph David Alexander baron Hohenbühel Heufler zu Rasen und Perdonegg (1817-1885) under the Section chief the writer later baron Adolph knight Kriegs (1819 Vienna-1884 Vienna) in 1866. In 1802–1811, Koller studied in Ljubljana with Kersnik. Koller studied higher mathematics in Vienna afterwards until he became a private tutor in Steinbach near Benedictine abbey Kremsmünster in 1814-1816. Koller lectured on physics and Natural history and headed the astronomical observatory in Kremsmünster Benedictine monastery after 1824. In 1848 he became a member of Viennese academy and got a Leopold's cross in 1859.²⁷⁸⁶

Between 20th January 1862 and 9th March 1863, the authorities run a process of Stefan's appointment as a full-time professor of higher mathematics and physics at the University of Vienna while he also became the co-director of the Physics Institute receiving his annual salary of 1680 guildens with an additional 157 guildens and

²⁷⁸⁴ John C. Crepeau, *Jožef Stefan: His Scientific Legacy on the 175th Anniversary*, March 2013, Sharjah: Bentham Science Publishers, p. 6; Čermelj 1976 32.

²⁷⁸⁵ Čermelj 1976 32; Vaniček, 1860, 3, 108.

²⁷⁸⁶ His principal work in meteorology and astronomy was printed in the Wiener Denkschrift in 1850. He also published in *Astronomische Nachrichten*, and in *Jahreshefte des naturforschenden Vereins* in Brünn.

50 kr.²⁷⁸⁷ The appointment of Stefan was already a secretary of state's introduction to Stefan's later replacement of the sick Ettingshausen.²⁷⁸⁸

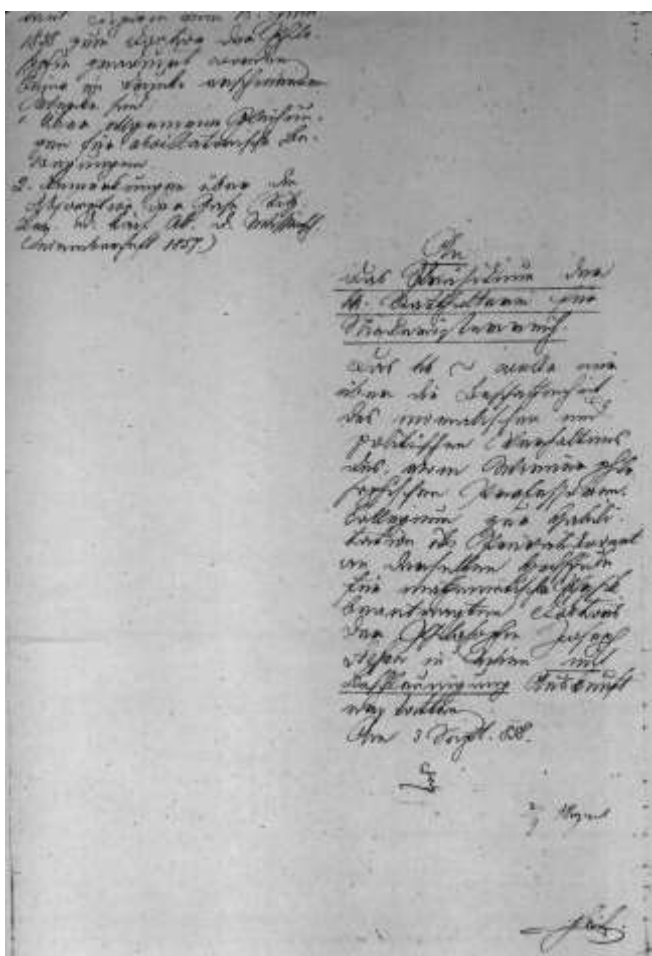

Figure 22-47: The second page of Stefan's application for habilitation issued on 3 September 1858. In the left upper corner, he listed his proposed paper on fluctuations, which was later published in Ann.Phys., and his work on the absorption of gases, on which he lectured at the Viennese Academy on 10 December 1857. He published that stuff in following year in the academic bulletin on 9. 12. 1858.

On 20 December 1862, on the supposedly given recommendation of the Emperor the liberal prime minister (Ministerpräsident) newly appointed honorary member of Viennese academy Anton Ritter von Schmerling (1805 Lichtental by Vienna-1893 Vienna) listed fourteen Stefan's published works, one of which was just a continuation of the previous work. Three of the afore mentioned basic

²⁷⁸⁷ Stefan Archive Wien 106_I_3988 Documents, 9 February 11863, p. IV.

²⁷⁸⁸ Stefan Archive Wien 106_I_3988 Documents, 26 January 1879, pp. 12-13.

works have not yet been mentioned in Slovene literature,²⁷⁸⁹ perhaps because Stefan there mostly discussed pure mathematics which soon ceased to be his main topics although it still attracted his best student Boltzmann. Stefan has published two of those previously unknown works in the then leading German mathematical Schlömilch's magazine, where they also printed papers about physics. Later, only the titles of Stefan's subsequent works were republished in Schlömilch's magazine.

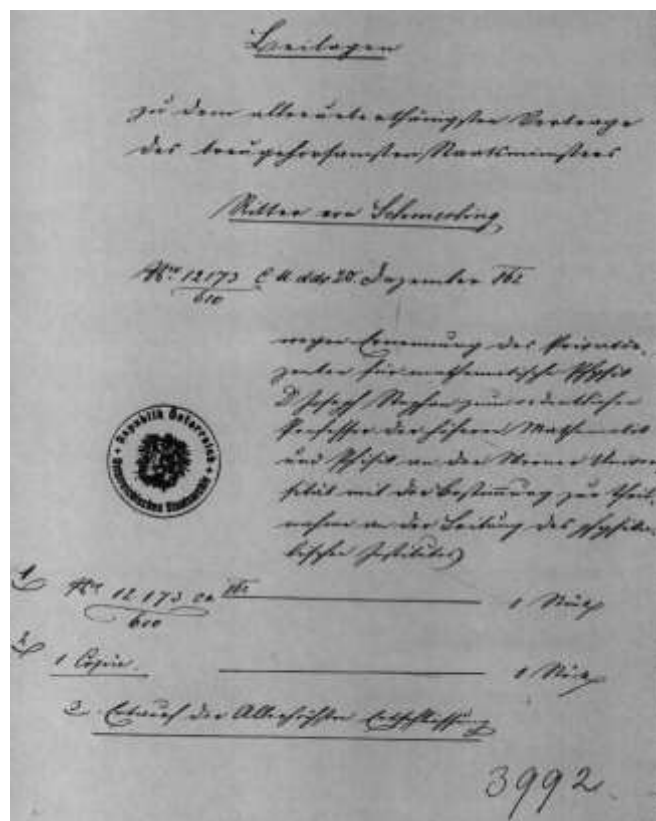

Figure 22-48: The cover letter of 20. 12. 1862, in which the Minister Schmerling recommended J. Stefan to the Emperor (Documents, 20. 12. 1862).

On 27th April 1865, Stefan was the first recipient of the prize of the wealthy Jewish banker Ignaz Isak Leopold Lieben (* 28 February 1805 Prague; † 12 March 1862 Vienna) in the amount of 900 Gulden. J. Stefan loved the opportunities to send some of his earnings to his bellowed mother back home, but she already passed away year and a half earlier to transform J. Stefan into a cosmopolite expatriate shaped by imperial wishes like Močnik. Until J. Stefan's domestic marriage, he spent both of his decades without singing of Slovenian songs of Carinthia. The Prague-Viennese Jewish

²⁷⁸⁹ Čermelj, 1976, 107-108; Sitar, 1993, 140.

community which brought up W. Pauli, Stefan Zweig and Sigmund Freud was on its ways up. J. Stefan got his Jewish Lieben's prize, but he did not welcome many Jewish guys in his Viennese Institute of physics as Stefan was far from E. Mach-Pauli Viennese Pro-Semitic circles in the times when the Viennese politics began to divide between the Jewish-infiltrated socialists and the future Nazis. The Jewish genius of physics and chemistry just began to emerge in USA with Helmholtz's doctoral student Albert Michelson (1852 Strzelno-1931 Pasadena) and in Prussia before Einstein with Helmholtz's Berliner students like the native of the free Hanseatic city of Hamburg with the greatest concentration of Jews in Germany Heinrich Rudolf Hertz (1857 Hamburg-1895 Bonn) or the Prussian Fritz Haber (1868 Wroclaw-1934 Basel) followed by Planck's Berliner assistants Max Abraham (1875 Gdansk-1822 Munich) and Lise Meitner (1878 Vienna-1968 Cambridge) who got her Ph.D. among the last in Boltzmann's class. The Prussians declared their full civil right to Jews in 1812 which was formalized in Habsburg empire only in 1867 long after many Jews joined the Habsburg empire with annexation of Galicia in 1772. The Jesuits used to be deeply hostile to the religious Jews, but the converts like Paul Guldin in Graz were very welcome. Stefan couldn't hire much more Jews in Vienna of his days even if he wished because physics was just becoming the goal of Jews and females in Stefan's days Vienna. The Slovenian areas were even slower before the first Jewish physicists of Ljubljana Ivan Kuščer (1918 Vienna-2000 Ljubljana) whose mother from Viennese Kautsky Austro-Marxist painting family was personal friend of Rosa Luxemburg, or the Russian-Jewish physician-chemist Evgen Kansky (1887 Warsaw-1977) and his son chemist-vacuum researcher Evgen Kansky (1926-1987). Stefan formally tried to stay out of daily politics, but nobody ever really succeeded in anything like that in this world.

Between 9. 6. 1866 and 10. 10. 1866 the procedure for retirement of Ettingshausen with an annual pension of 4000 florins was completed.²⁷⁹⁰ The career of J. Stefan profited from his abandoning of early poetic Slovenian nationalism for his unquestionable loyalty to Habsburg comparable to Jewish Viennese loyalty which was challenged by

²⁷⁹⁰ Stefan Archive Wien 106_I_3988 Papers, 20 September 1866, pp. 11-12.

the Anti-Semitic Catholic Viennese mayor Karl Lueger (1844-1910) only after J. Stefan's death. The minister Schmerling proposed and suggested that Stefan should take over Ettingshausen's senior physics chair and become the sole director of the Physics Institute and a professor at the University, with an annual income of 3500 guilders including the opportunity to have his flat in the building of Institute of physics. The appointment was signed by Franc Josef with a somewhat lower annual income in his imperial residence in Upper Austrian Bad Ischl on 1/10/1866. Ettingshausen entrusted his students to his disciple Stefan, because they were of the same opinion on the importance of atomism, kinetic theory, and vacuum experiments for further development of the physical sciences.

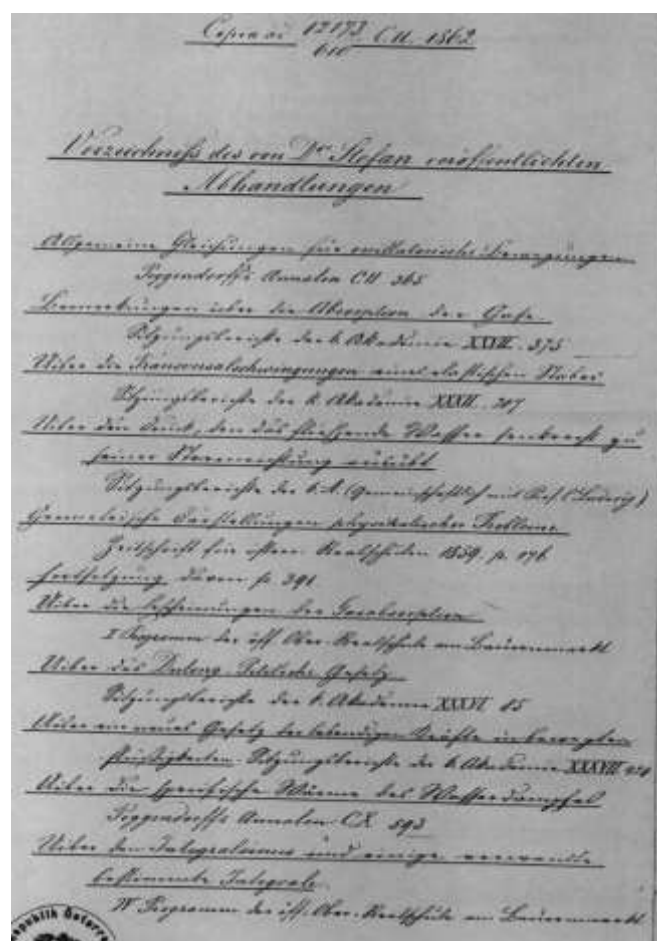

Figure 22-49: The first part of Schmerling's 20th December 1862 listing of fourteen Stefan's published works, one of which was only the continuation of the previous publication (Documents, 20. 12. 1862).

By order of 7 April 1873, Franc Josef I elevated Stefan to the first payment class-grade. His annual salary was increased from 3000 to 3500 florins according to the proposal of the Minister for the

Education and Worship the liberal Karl Edler von Stremayr (* 1823 Graz; † 1904). For unmarried, modest Stefan, this was a great salary, it was quite a paycheck.

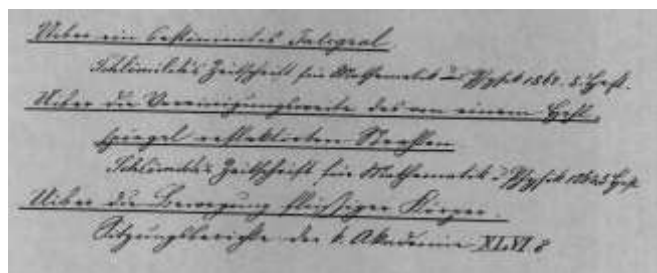

Figure 22-50: Continuation of Schmerling's listing of the fourteen Stefan's published works noted on 20th December 1862 (Documents, December 20, 1862).



Figure 22-51: Emperor Franc Josef I in Vienna approved the appointment of Jožef Stefan as a professor of mathematical physics at the University of Vienna (Documents, 26. 1. 1863). Three years later between 9 June 1866 and 10 October 1866, Ettingshausen retired with the annual pension of 4000 fl.

In 1878, Ettingshausen died; his former student Stefan published his obituary for the Viennese Academy. On 27 October 1878, Stremayr's secretary of state of Educational and Religious Affairs (School and Worship) proposed Stefan and a professor of mineralogy and petrography Tschermak for the new court councilors. In his letter, the secretary of state Stremayr described their merits and life paths. Stremayr gave Stefan full credit for the Habsburg-Austrian

mathematical-physical research comparable to the English, French and German scholars. Among Stefan's achievements he listed: taking over the secretarial work of the mathematical-science class of the Viennese Academy after the deceased professor of chemistry Kristelli, the rectorate at the university in the school year 1876/77, the leadership of the Habsburg-Austrian commission for teaching at the exhibition in Paris and membership in the Grammar school (gymnasium) examination commission. Stefan was also the Commissioner for Physics and Physical Textbook Consultant at the department of state.²⁷⁹¹ The third Parisian World's Fair, called an Exposition Universelle in French, was held from 1 May through to 10 November 1878. Among the many inventions on display was Alexander Graham Bell's telephone. Electric arc lighting had been installed all along the Avenue de l'Opera and the Place de l'Opera. In June, a switch was thrown, and the area was lit by electric Yablochkov's arc lamps, powered by Zénobe Gramme's dynamos. Thomas Edison had on display a megaphone and phonograph. International juries judged the various exhibits, awarding medals of gold, silver and bronze. In 1867 or more probably in 1878 Stefan obviously participated in that Parisian spectacle which might have been one of his rare journeys abroad. The second Parisian exposition with Carniolan Agricultural company participating with cereals was in 1867, the third under general commissioner navigational-construction engineer Jean-Baptiste Krantz (1817–1899 Paris) in 1878. In 1878 Austrian delegation was headed by emperor's son Rudolph. The director of Trieste school Vlacovich presented his physics lectures and many Ljubljana erudite also participated. Stefan's Parisian Habsburgian commission for secondary school teaching was officially headed by his Viennese university classmate Alexander Anton Bauer (Sandor, 1836 Altenburg (Mosonmagyaróvár)-1931 Vienna) who taught general chemistry at Viennese Polytechnic and organized the first chair of electrotechnics as the rector of Polytechnic in 1882/83 in connection with Stefan's technical leadership of the Viennese electrical exhibition of 1883.

The secretary of state Stremayr described Stefan and Tschermak as good and reliable in political and moral terms and respected among colleagues.

²⁷⁹¹ Stefan Archive Wien 106_I_3988 Papers, 27 October 1878, pp. 4-5.

Franc Josef signed the order appointing those two new court councilors in his imperial residence in Gödöllő in Budapest metropolitan areas on November 1, 1878. Tschermak was otherwise Stefan's opponent. He criticized Stefan's (1858) extension of the Dulong-Petit's law approximately valid for solids all the way to gases, which Tschermak's opinion was also shared by S. Šubic. In 1893, Tschermak even suggested Mach as Stefan's successor at the University of Vienna and opposed Boltzmann's candidature for Stefan's chair.²⁷⁹²

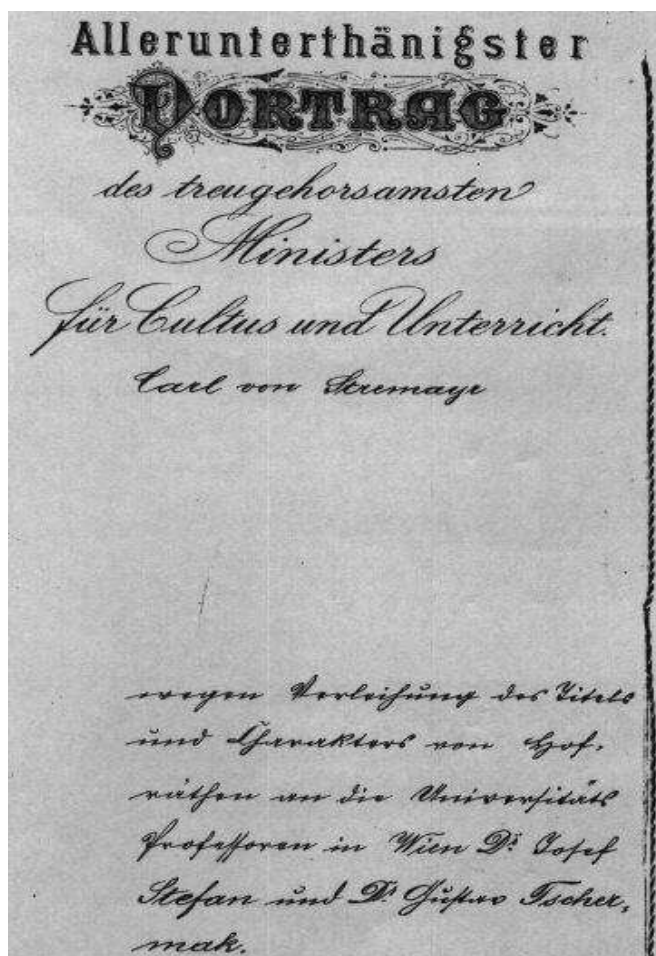

Figure 22-52: The official head seal of secretary of state Stremayr upon the proclamation of Stefan as a court councilor on 11. 11. 1878 (Stefan Archive Wien 106_I_3988 Documents, 1. 1. 1878).

With this appointment, Stefan's career reached a peak. In the 1860-s and 1870-s, he was also an adviser to the secretary of state for the Strengthening and graduating of the Quality of Scientific Works and for granting scholarship for higher studies of physics, including even the

scholarships for the study abroad.²⁷⁹³ He thus directed the entire physical research in the monarchy and followed his teacher Ettingshausen in the research of atomism by using the evolving vacuum techniques.

22.2.7 Stefan Exploration of Kinetic Theory and Atoms

In the beginning of Stefan's scientific pathway, the director of the Polytechnic in Karlsruhe Ferdinand Redtenbacher (* 1809; † 1863) published the theory of smallest ultimate material elementary nuclei with envelopes made from the ether in 1852 and 1857. Redtenbacher's theory was based on Regnault's experiments and on the model of vibrations in solids and gained a great initial support in Habsburg monarchy thanks to the key position of Ferdinand Redtenbacher's influential cousins in the Viennese academy.

In Germany, a more contemporary theory was simultaneously published. It was designed by Krönig, director of the real school and editor of the *Fortschritte der Physik* in Berlin in 1856, and by Clausius, a professor at the University of Zurich in 1857. Their kinetic theory was based on the translation of molecules in gases and did not explicitly adhere to any model of atoms, ether or vacuum. Therefore, Redtenbacher generalized his vision based on solids to a general approach for all substances while his opponents Krönig and Clausius extrapolated their vision of gases to the other aggregate states. The key question on which the merger of both theories was broken was the behavior of the substance at low pressure in vacuum experiments. Just as the development of mathematics has always been propelled by the (Indian) ideas about the infinitely small quantities of Zenon's paradox of motion, Newton's infinitesimal calculus, and Cantor's paradoxes of groups, modern physics has advanced and progressed primarily through vacuum experiments, which were therefore equally focused on the infinitely small quantities, in their cases on the infinitely small densities and pressures. While answering the puzzling question of vacuum, of course, even great philosophical theories have failed, such as Descartes' and Aristotle's ideas.

²⁷⁹² Tschermak, 1860, 11; Höflechner, 1994, 1:148.

²⁷⁹³ Höflechner, 1994, 1:20.

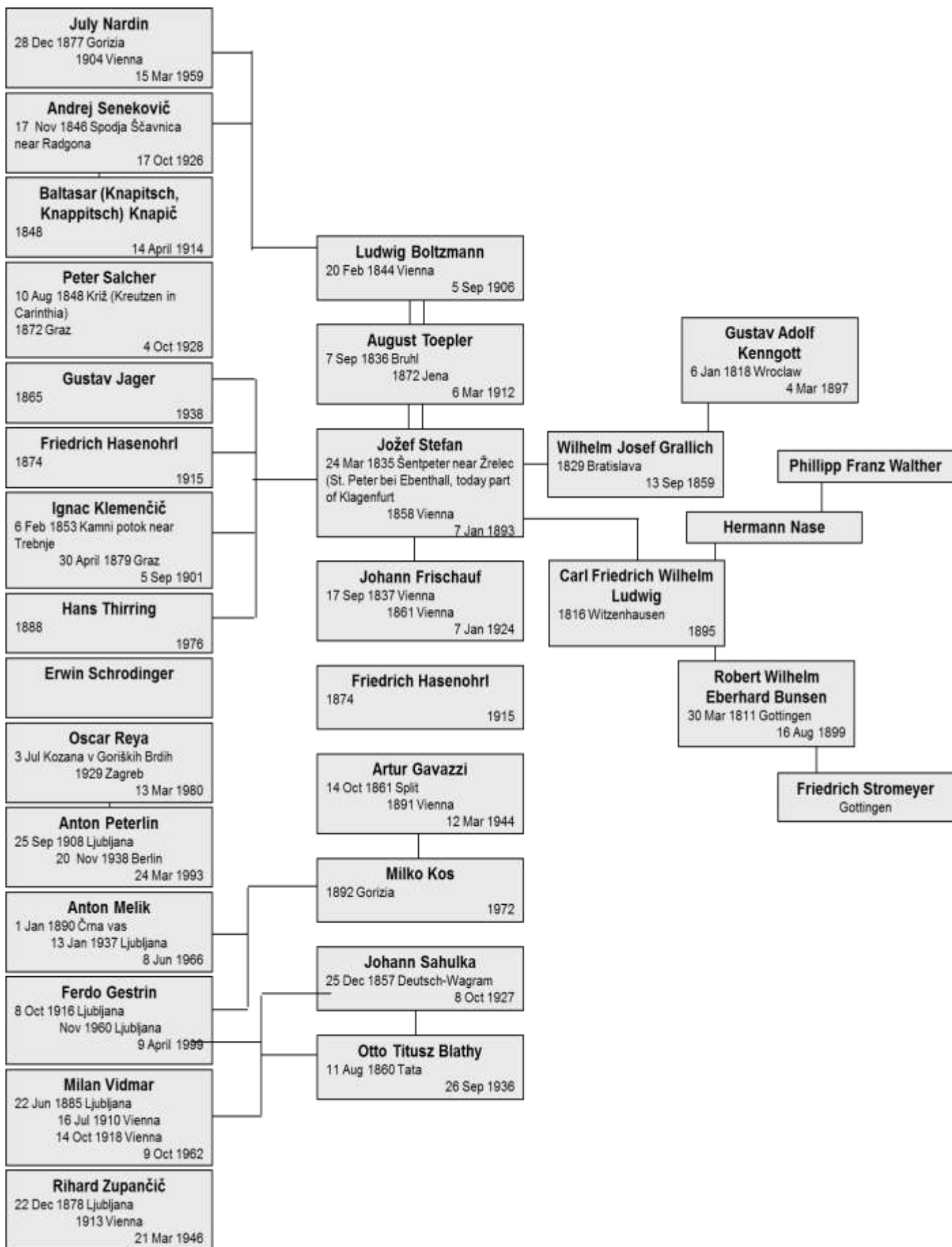

Figure 22-53: Stefan's academic descendants and ancestors in Ludwig and Grailich's branches.

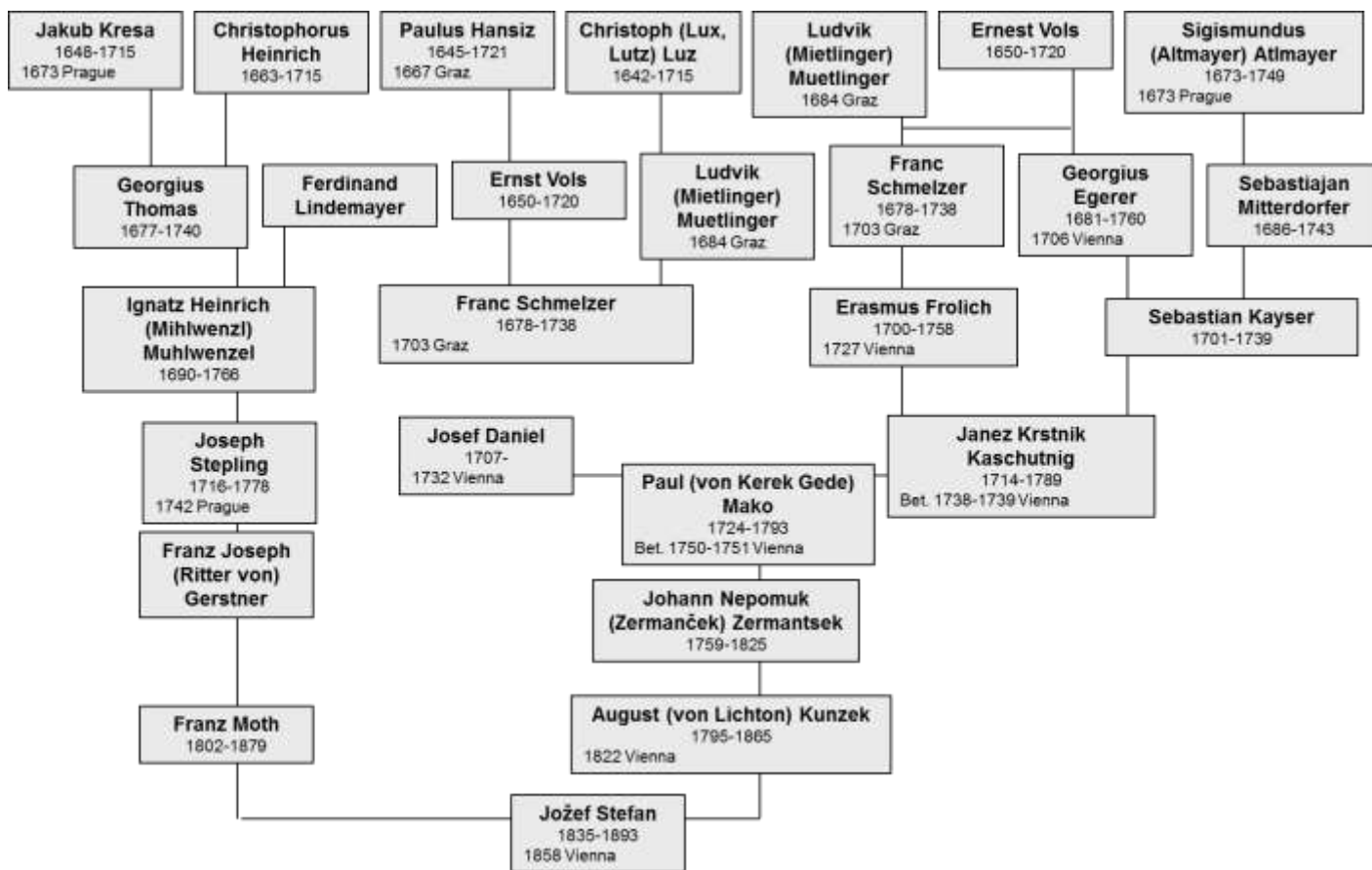

Figure 22-55: Stefan's academic descendants and ancestors by the Viennese Moth and Kunzek's branches.

When Stefan began his research work in the 1860s, the kinetic theory of gases with the theory of vacuum went into problems that originated from differences in the methods of Clausius and Maxwell, and from lacking of adequate measurements of transport coefficients.

Stefan was a proponent of kinetic theory; nevertheless, in 1872, he chose the model of an atom close to F. Redtenbacher's *Dynamides* which probably gained some support of F. Redtenbacher's Viennese based relatives. While Clausius generalized the gas model and the translation of molecules for all thermal phenomena, Redtenbacher in a similar but opposite way expanded his own use of the model of vibrations of molecules in solids. Between those alternatives of solids and gases, Stefan chose the intermediate path focused on use of the liquid model as suitable for all forms of heat. Stefan's alternative was also acceptable for the proponents of Clausius' kinetic theory of gases because Thomas Andrews' data and later Van der Waals' researches proved that the phase transitions between liquids and gases were much smoother than the transition into crystalline solids. Stefan

chose the established theory of hydrodynamics as the base his research, although Stefan very early as a student dismissed hydrostatics as boring,²⁷⁹⁴ probably because it was so convincing without much researching alternatives left. The idea was very clever because the 18th century industrialized hydrodynamics used for high society entertainments and parks was the most advanced and finished theory inside physics except for the geometrical optics. Stefan's expansion and spread of heat was considered and treated as a special branch of hydrodynamics. Analytical mechanics has been supplemented by the thermal spread of matter and internal friction.²⁷⁹⁵ So, we can have Stefan's research of thermal phenomena as the continuation of the Fourier research of transfer of heat published in its final form in 1822.

Stefan used the measurements of hydrodynamic in blood capillaries of the Parisian physician Jean Leonard Marie Poiseuille. Poiseuille's reducing of internal friction in the capillaries at a rising temperature questioned and doubted Maxwell's model of elastic balls which was announced in

²⁷⁹⁴ Ivan Šubic 1902, 75.

²⁷⁹⁵ Pourprix, Locqueneux, 1988, 96.

1859. According to Maxwell, the internal friction should increase with rising temperature.²⁷⁹⁶ Stefan treated the spread of heat and the diffusion of gases as the hydrodynamic phenomena²⁷⁹⁷ in contrast to Graham who took a diffusion of gases for a chemical phenomenon. Stefan did not even accept Maxwell's "ad hoc" model of molecules with a force proportional to fifth potency of the distance. Maxwell's model provided the acceptable diffusion coefficient proportional to the temperature.²⁷⁹⁸ However, Maxwell's model did not allow the determination of the internal properties of gas. That is why Stefan published his dynamic model of gas²⁷⁹⁹ in which the radius of the molecule decreases with some power of the (absolute) temperature. In Stefan's model, the radius of faster molecules diminished due to increased possibilities of interpenetrations during their mutual collisions. The repulsive force is then proportional to the velocity, just as French Navier argued and claimed as early as in 1826.²⁸⁰⁰

Stefan thought within the sphere of force model, without explicitly declaring the molecules to be like solid bodies. The repulsive force between molecules must operate at greater distances, so that it can affect viscosity.

After 1872, Stefan with his hydrodynamic analogy mainly avoided and ignored the assumptions about the properties and characteristics of molecules and vacuum between them.²⁸⁰¹ Later he no longer published papers on "real" characteristics of atoms, since the critics of E. Mach and Ostwald's energeticists made Stefan afraid. He left a direct controversy to his former student Boltzmann who was a bull designed to fight down the matador Ostwald but not before Stefan passed away. Between 1873 and 1876, Boltzmann and Stefan were in daily contact as the colleagues at the University of Vienna. Their talks were described by Boltzmann in a letter to his later wife of the half Slovenian genus named Jeti on 23 March 1876.²⁸⁰²

²⁷⁹⁶ Stefan, 1872, 8.

²⁷⁹⁷ Pourprix, Locqueneux, 1988, 96, 98.

²⁷⁹⁸ Jovan Mitrović (Sarajevo), Jožef Stefan and the dissolution-diffusion phenomena - Not only a historical note. *International Journal of Pharmaceutics*, 15. 7. 2012, 431/1-2: 12-15.

²⁷⁹⁹ Stefan, 1872, 16; Boltzmann, 1880, 131; Pourprix, Locqueneux, 1988, 102.

²⁸⁰⁰ Pourprix, Locqueneux, 1988, 88, 105.

²⁸⁰¹ Pourprix, Locqueneux, 1988, 100.

²⁸⁰² Flamm, 1995, 161.

A similar hydrodynamic model was used by researchers of electricity who assumed that ether and electricity are the same. Their negative electricity would then be the lack of ether, and the potential difference would then indicate the overplus of the ether. Among these researchers, besides the fans of Franklin's one-fluid electrical theory, were the Italian Jesuit and astronomer Secchi, the Swedish native Edlung (1871), Tesla, and Habsburgian Ukrainian Puluž (1880) known for his studies and experiments in vacuum at the Stefan's Institute of physics as he joined his decade older fellow Stefan already at the Exposition Universelle in Paris in 1878. Puluž collaborated with Nikola Tesla in A. Kundt's Strasbourg lab, resembled Tesla with his religious studies in his Orthodox' networks and worked in Mach's German part of Prague university.

22.2.8 *The Radiation Law of Stefan*

In 1878, Stefan read the "thirty-one-year-old" paper of the New York professor of chemistry and physiology Draper on the influence of electricity on capillaries, where the problem of the exponential increase in the density of the irradiated energy stream flow with temperature was not solved.²⁸⁰³ Stefan decided to solve the puzzle by himself in probably the best research choice he ever made.

On March 20, 1879 Stefan submitted to the Viennese Academy a paper on radiation. The handwritten summary of the paper was four pages long in A4 format. He wrote the whole paper in his manuscript on 61 pages and printed it on 38 pages.

Half of the paper included its first part about the experimental attempts of Dulong and Petit and the shortcomings of their law "of the geometric increase of the amount of heat in the areas of red-hot grill while the temperatures are rising in the arithmetic sequence". Stefan's fourth-power equation was more in line with the experiments of French school inspector Frédéric Hervé de la Provostay and his friend the professor at Sorbonne Paul Quentin Desains (* 1817; † 1885) at low temperatures. Stefan's equation supposedly had an advantage in theoretical terms²⁸⁰⁴ which Boltzmann proved few years later.

²⁸⁰³ Draper, 1846, Rosenberger, 1890, 448; Sitar, 1993, 82.

²⁸⁰⁴ Stefan, 1879, 2, 20; Strnad, 1985, 75.

Dulong-Petit's law was already 62 years old upon Stefan's research. In the meantime, new measurements were made, especially regarding the temperature of the Sun. The theoretical complaints were even more substantive, since in Dulong's time it was not known that thermal conductivity was independent of the density of gas.²⁸⁰⁵ This was the most striking finding of Maxwell's kinetic theory of gases, which he described in a letter to Stokes in 1859 and published in the following year.

With Maxwell's theory, Stefan realized that Dulong and Petit really got rid of convection in their measurement of thermal radiation, but they did not exclude the transfer of heat with translations through conductors.²⁸⁰⁶ At the time of Dulong and Petit's measurements, folks doubted whether the air was even able to translate the heat. The problem had been solved only by Stefan and his colleagues at their Viennese institute of physics with their measurements of the thermal conductivity of gases in the 1870-s. In the measurements with his newly invented diathermometer Stefan used the best achievements of then available vacuum technique.

According to the British results, Stefan already knew that there is also the third possibility of spread of heat, namely the one which involved the infrared radiations. Therefore, in his second part of the paper, Stefan determined the size of the thermal radiation in absolute units. He compared Desperetz' experiments with the experiments of Joseph Prudent Frédéric Herve de la Provostay from Parisian college Louis-Le-Grand and Desains from Sorbonne. All of them offered considerably lower results with their values of the thermal radiation.

In the third part of his paper, Stefan discussed the experiments of Draper and Ericsson. The paper began with a report on Wüllner's textbook adaptation of Tyndall's experiments, which should be especially well-compliant with Stefan's law as a great confirmation. So far, that half-page had been an essential part of Stefan's paper.²⁸⁰⁷ However, Stefan did not even mention Wüllner and Tyndall in Stefan's handwritten summary of his work. Even in his published article, their measurement

seemed less important than the measurements of Draper and Ericsson, with which Stefan addressed the third chapter of his paper. It is highly probable that Stefan learned about Wüllner's publication of Tyndall's results after Stefan wrote his manuscript and before his final publication, therefore Stefan added that data to his work, but more as the minor proof as Tyndall evidently did not provide any kind of very exact measurements. In later development of knowhow Tyndall influential enthusiastic reading of Stefan's law became decisive because Tyndall was probably happy to see his own contributions there although everybody knew that they were not any kind of exact science.

In the fourth part of his paper, Stefan determined the temperature of the Sun. He used the measurements of the Frenchman Claude Servait Matthias Pouillet, and above all mostly the experiments of Charles Soret, a professor at Geneva (Genf). So, Stefan as the first one offered a meaningful useful sensible value for the temperature of the Sun as 5580°C. Charles Soret (1854, Geneva-1904) was the son of Jacques-Louis Soret, professor of physical medicine at University of Geneva. Charles graduated in Geneva and continued studies in mathematics at the Sorbonne. Soon, he was offered a place in the Department of crystallography and mineralogy at the University of Geneva where he published his first discussion on thermo-diffusion based on the experiments with solutions of NaCl and KNO₃ in pipes with heated or cooled ends in 1879. He noticed higher concentrations at the cooler end of the pipe. His experiments confirmed the results of Stefan's mentor-supporter Carl Friedrich Wilhelm Ludwig (1816-1895) published 20 years earlier of which Soret probably did not know. Soret connection with Ludwig might have been the main reason for Stefan's enthusiastic use of Soret's results.

In contrast to Boltzmann Stefan was quite superficial in his citing and sloppy in quoting. Thus, in the paper of 1879, more than ten researchers were mentioned with no accurate references. Stefan quote of Draper and Ericson's work was incomplete; according to modern criteria, unfortunately, only Stefan's description of the work of Dulong and Petit from 1817 is a correct valuable citation. In Stefan's time that kind of quoting was no major flow as all researcher knew each other and understood well all the points

²⁸⁰⁵ Stefan, summary 1879, 2.

²⁸⁰⁶ Stefan, 1879, 2.

²⁸⁰⁷ Stefan, 1879, 31; Čermelj, 1976; Strnad, 1985; Stefan, 1879, 421, 422, 393.

they were talking about, while in the next generations of Boltzmann the number of researchers involved increased so much that the exact citations became notorious, especially after the quotations became the critical point for the valuation and substantial financial state support of the researcher-author in question.

22.2.9 *Stefan's Law among his Contemporaries*

On 1 July 1876, Bartoli of the University of Bologna announced that thermal radiation in a vacuum radiometer opposed the second law of thermodynamics with Bartoli's supposedly contrary evidences which was a potentially fatal blow to all Boltzmann's networks. His ideas emerged from his research of vacuum in a radiometer, which Crookes had shown three years earlier before the Royal Society in London. Unlike Crookes, Bartoli was immediately confident and convinced that the radiometer did not measure the absolute vacuum²⁸⁰⁸ because Bartoli relied on myriads of his Florentine academic ancestors' research of vacuum including Torricelli.

The Florentine native Bartoli studied physics and mathematics in Pisa until 1874. In 1876 he became an assistant at the University of Bologna and a physicist in Arezzo, in 1878 in Sassari, in 1879 at the Technical Institute in Florence, in 1886 at the University of Catania, and at the University of Pavia in 1893 when Pavia of Bošković and Volta was no longer ruled by Boltzmann's Habsburgians. He has published seventy-nine papers in the leading Italian newspaper *Il Nuovo Cimento* in Pisa. He focused every effort to his study of electric and thermal phenomena. Bartoli's theory of the pressure of light was like Maxwell's and enabled the first measurements. Lebedev published his experiments on the foundations of Bartoli's suppositions in Moscow in August 1901; the Russian Lebedev used G. Kahlbaum's Berlin vacuum pump and he measured the pressure with McLeod's manometer.

Thus, the experimental research of the vacuum began to influence directly the research before the publication of Stefan's law. In 1883, Bartoli's idea was supported by Henry Turner Eddy (1844-1921), a professor of mathematics and astronomy at

Cincinnati University who studied in Yale, Paris and Berlin. Boltzmann criticized his peer Eddy. Like Stefan, Boltzmann read about Bartoli's research only in Eddy's work after Stefan gave Boltzmann the English vocabulary to learn enough to study Maxwell's works. The associate professor at Leipzig E. Wiedemann later edited the central physical magazine *Ann.Phys.* with his father G. H. Wiedeman in Leipzig and had a much better overview of Italian publications; so, he read Bartoli's work among the first Germans.

Boltzmann dealt with Bartoli's work in 1884, just before Boltzmann's theoretical derivation of Stefan's law.²⁸⁰⁹ Even Stefan probably did not know Bartoli's reflections on vacuum in a radiometer from 1876 until Bartoli's ideas were publicly supported by Eddy. Therefore in scientific networks geographically nearby Pavia was much more distant from Vienna than the faraway USA, which became even more true in following century where the USA ownership of scientific and other media became so prominent that only the more democratic web provided some slight chances to others to challenge USA monopoly of media. That is why Bartoli's radiation studies did not decisively influence Stefan's path to the radiation law in 1879.

Naturally, like all other physicists of his era, Stefan was very interested in vacuum experiments in a radiometer. Stefan had several close contacts with Italian researchers, especially with his former colleague at the Viennese Physical Institute Blaserna, who was the president of the Roman Academy dei Lincei since 1904.

From 11 August 1883 to 3 November 1883 the electrotechnical exhibition in Vienna could have influenced Boltzmann's interest in radiation theory. On 25. 10. 1883 Stefan as a scientific leader of the exhibition met with the Honorary Chairman of the Technical-Scientific Commission William Thomson, the later Lord Kelvin. Together with William Siemens they were solemnly accepted by the English embassy in Vienna. William Siemens as a German-born British industrialist even lectured on the radiation inside vacuum in Vienna.²⁸¹⁰ Unfortunately, Siemens did not mention Stefan's law, although he knew our hero Stefan well. From such a short resentment on radiations in vacuum we will never know all

²⁸⁰⁸ Bartoli, 1879, 274.

²⁸⁰⁹ Höflechner, 1994, 1:80.

²⁸¹⁰ Sitar, 1993, 87, 92-93.

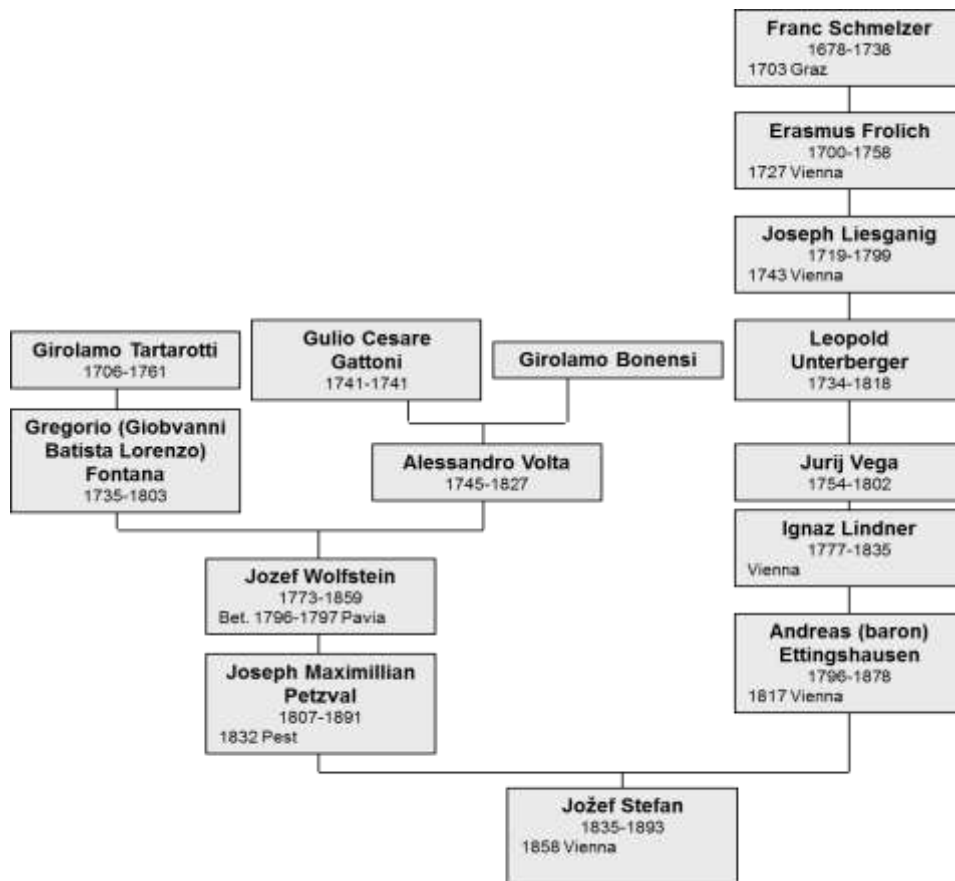

Figure 22-56: Stefan's academic descendants and ancestors in Petzval and Ettingshausen's Viennese branches

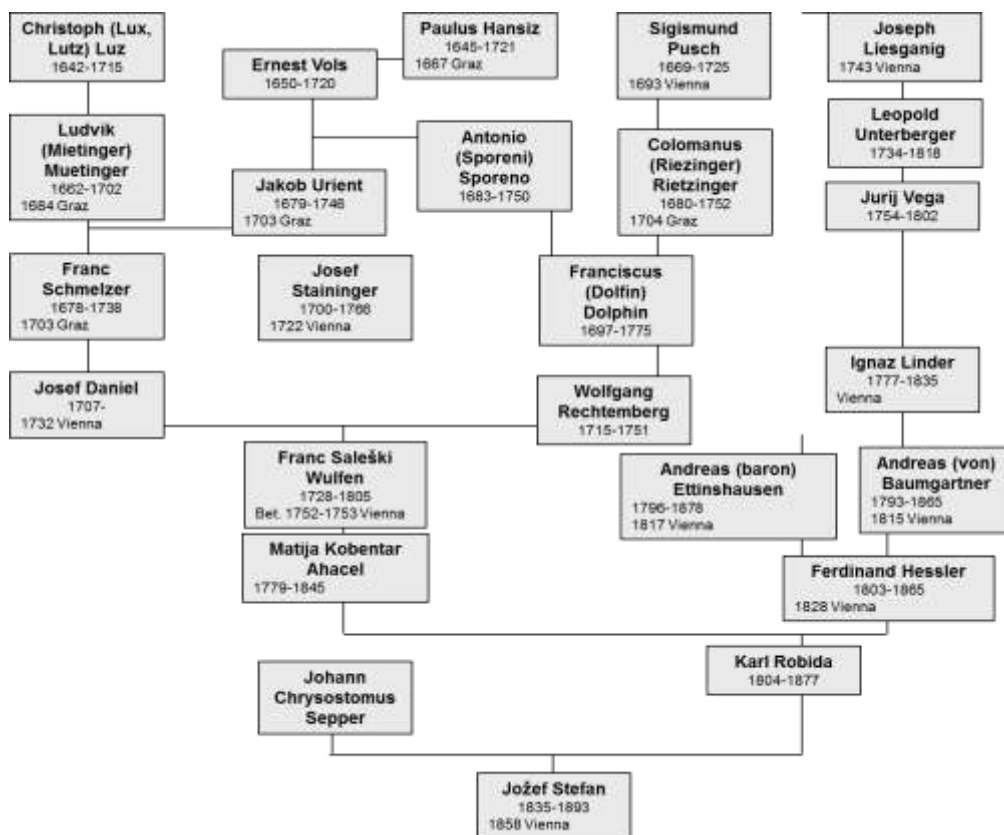

Figure 22-57: Stefan's academic descendants and ancestors in Robida and Sepper's Klagenfurt Grammar school branches

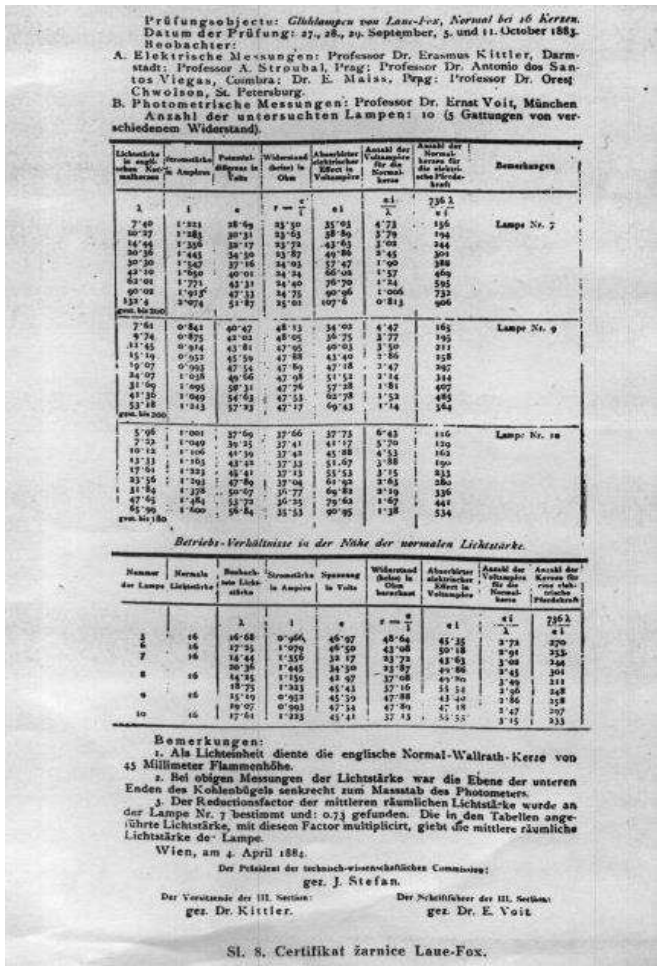

Figure 22-58: In 1884, Stefan signed certificate for a Lane-Fox English vacuum bulb with glowing charcoal in the shape of a horseshoe at a Viennese exhibition.

Siemens' whereabouts and ideas about Stefan's law, since Siemens suddenly died in London only fifteen days after the end of Viennese exhibition. Just four years after Edison's invention Stefan presented the facts of Edison's vacuum lamp to the Viennese mayor Eduard Uhl (1813-1892) with his municipal representatives included and even the Habsburg Crown Prince Rudolf was there soon after the birth of his only legitimate daughter Elisabeth on 2 September 1883.²⁸¹¹ Rudolf sadly passed away five years later with his other lover. Stefan explored the light bulb as an example of his own theory of radiation. At the same time, he inherited the tendency towards useful application of knowhow of his teacher Ettingshausen and emphasized the advantages of the lighting bulb against other sources of light. Wächter and Puluj as the members of Viennese physics institute and Stefan's co-workers also showed their own designs of vacuum bulbs at the Viennese exhibition under

²⁸¹¹ Sitar, 1993, 93.

Stefan's leadership. Puluj had already taken over his new chair in Prague, but he kept his vivid contact with the Viennese researchers of vacuum. Stefan has been evaluating the capacities of bulbs during several years following the Viennese exhibition. He has been expecting that the very experiments with radiation in vacuum bulbs will help to recognize his theory of radiation; the modern experiments fully justified his hopes.²⁸¹²

The Viennese exhibition and subsequent important papers published about vacuum bulbs have greatly contributed to the popularity of Stefan's radiation law. By conducting the exhibition, Stefan became authority for the manufacturers, producers and users of the lamps, thereby Stefan paved the success of his own law. Nevertheless, during the first five years Stefan's equation was supported mainly by physicists writing in German language.²⁸¹³

²⁸¹² Prasad, Mascarenhas, 1976.

²⁸¹³ Lummer, 1900, 61-63; Brush, 1976, 511, 517; 1985, 75.

23 Major Industrial Uses of Vacuum Technologies for Roentgen

23.1 Roentgen Rays for Electronic

Stefan probably met Edison during the Viennese exhibition of 1883 or later. Edison's fans and his antagonist Americans had a huge politically colored quarrels about the possible scientific values of light bulb research while nobody doubted that J. Stefan's part of it was scientific. Because Stefan was academic person and Edison just wanted to be one. Their cathode ray tubes soon wrote another page of history. At the turn of the 19th century, the fifty-year-old Röntgen discovered mysterious X rays. The novelty was immediately put into use, especially in medicine and in military affairs. With a little help of X-rays many new facts were discovered in a few years. Their nature was explained only by the next generation of researchers in quantum mechanics.

23.2 Röntgen's Research on the Detection of Rays



Figure 23-1: Wilhelm Conrad Röntgen(* 1845; † 1923)

Röntgen was a lively high school student and had fingers in teenage caricature of professor at the Technical School in Utrecht (Figure 23-1).

The alleged artist was immediately excluded from school and could not complete his graduation; so, he studied at the Polytechnic in Zurich between 1865 and 1868, much like Einstein and his wife later because the Matura was not required for matriculation in Zurich. Roentgen learned most of his physical subjects at Zeuner's class, and in the second year he attended technical physics courses at the University of Zurich in the class of Clausius, who had just recently established a modern kinetic theory of heat and gases. In addition to Zeuner's lectures on mechanical heat theory, Röntgen also listened to Clausius's optional lectures on the same substance where Röntgen was deeply influenced by Clausius' abstract clarity and accuracy. In 1868, young Kundt was elected as Clausius' successor. After Röntgen's dissertation on gases in 1869, Kundt pushed the mechanic engineer Röntgen into physics.

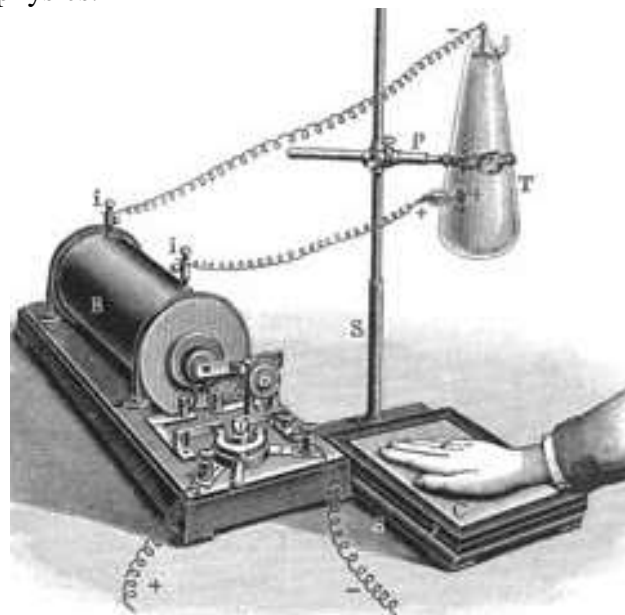

Figure 23-2: An experimental device to record the first X-ray of the human hand.²⁸¹⁴

23.3 Discovery

On 7. 5. 1895, Lenard from Bonn fulfilled Röntgen's demand and sent to him an ordered tube made by the glassblower trained in Geissler's Bonn headquarters Louis Müller-Unkel's (1853-1938). Louis headed his Institut zur Anfertigung chemischer, physikalischer und meteorologischer Glaspräzisions-Instrumente in Braunschweig. His

²⁸¹⁴ Heinrich Oscar Günther Ellinger (1857 Copenhagen-1947), *Naturen og dens Kræfter. Populær Fysik*. Copenhagen: Frem, 1897-1898.

glass cathode ray tube had an anti-cathode of 0.005 mm thick aluminium, which radiated the "cathode rays". Later it turned out that lightweight aluminium was the worst choice for experiments with X-rays. On 28 December 1890, Röntgen listed three different vacuum tubes, with which those new rays could be observed. We have different testimonies, colored with different interests regarding Lenard's priority about the device which Röntgen used for his discovery on 8 November 1895.²⁸¹⁵



Figure 23-3: The X-ray image of a left hand with a wedding ring of his colleague Alberto von Koelliker (1817-1905), taken by Röntgen on 9. 3. 1896.



Figure 23-4: Manuscript and Cover page of the First Röntgen Discussion on the New

Röntgen used a large Ruhmkorff induction device of Ferdinand Ernecke's (1832-1914) Berliner firm.

²⁸¹⁵ Glasser, 1959, 51–56, 3; Harig, 1936, 304.

The tube was covered with a thin, screw-fitting cardboard. In the darkened room, even from the distance of 2 m, Röntgen noticed a fluorescence on a paper screen painted with barium platinocyanide, which he placed near the tube. Photographs were initially used to confirm the observed fluorescence. Already in 1895, Röntgen photographed, among other things, the bones of his wife's hand with a ring and a non-homogeneity in a piece of metal, which opened up a wide area of application next year (Figures 23-2 and 23-3).

In 1896, Röntgen published experiments in which he replaced the cardboard with a galvanized sheet metal box that had a window made of lead (Figure 23-4). He used a 3 cm thick and 45 cm long brass tube of 1 cm wide window, covered with aluminium sheet.²⁸¹⁶

23.4 Disputes on the Nature of X-Rays

Along with copies of his first discovery on December 28, 1895, Röntgen also sent X-ray photographs to established researchers worldwide. The use of the photos supported the feelings that the new rays were waves because most of photography recoded visible light. Röntgen found that the new rays are not the same as cathode rays, since the electric charges do not affect them. Also, they are not UV light, because they do not diffract, they are incorrectly reflected, they cannot be polarized, and their absorption depends on the density of materials.²⁸¹⁷

Boltzmann commented on Röntgen's discovery on 15 January 1896 and 22 September 1899; Kelvin added his ideas on 12 February 1896 and, together with other Britons, initially supported Röntgen's theory of the longitudinal waves of the ether. However, on February 25, 1896, he changed his mind as most of Brits did. At the lecture on 10 June 1896 J.J. Thomson gave priority to X-rays as transversal waves with shorter wavelength compared to UV light.²⁸¹⁸

In Prague, Puluj²⁸¹⁹ also rejected Röntgen's unfounded hypothesis of longitudinal rays. But

²⁸¹⁶ Röntgen, 1898, 1, 5, 6–7, 12–14; Glasser, 1959, 1–2.

²⁸¹⁷ Röntgen, 1898, 10.

²⁸¹⁸ Wheaton, 1983, 18; Wilson, 1987, 172; Feffer, 1989, 57.

²⁸¹⁹ Puluj, 1896, 238.

23.5 Experimental Determination of the Nature of X-Rays

only the Englishman Barkla excluded any longitudinal possibility with proves of polarization of X-rays in 1904 and picked up the Nobel Prize in Physics thirteen years later. In January 1896 in his laboratory Puluj shot many X-ray photographs for doctors and surgeons. Even patients from a relatively remote Cologne arrived to get their X-ray photography in Puluj's lab.

Lenard considered that Röntgen described the very rapid cathode rays that Lenard himself had discovered before him. Together with other German physicists, he opposed the British theories of cathode rays as particles or electrons.

Besides the basic contradiction, there were also different theories of new rays. The Englishman WH Bragg in Australia and the Serbian Tesla in the US considered X-rays to be small particles that could spew out electrons from atoms on August 1, 1896 and August 29, 1896. On 23 January 1896, Schuster from Manchester announced that, that "cathode ray" emits X-rays from solids. Similarly, on March 26, 1896 Stokes and Wiechert argued that the braking of electrons produces very short pulses of X-rays.²⁸²⁰ Stokes' idea that "each charged molecule creates such a pulse as it runs along the wall" was a compromise between the particles and waves adopted by most British physicists in the first decade of the 20th century.²⁸²¹ Stokes's pulse theory resembled Descartes's light as the pressure in a transparent medium as a compromise between emission theory of corpuscles and the undulatory theory of waves of light in a way that disputed ideas repeats themselves in history.

BIOGRAPHY: Philipp Lenard from Bratislava studied under supervision of the professor Helmholtz and received his doctorate at Bunsen's class in Heidelberg. As an assistant he served his five years older superior Jew Hertz in Bonn and after his death he published Hertz's collected works with mechanics included and led the Bonn Physics Institute. He then became professor in Breslau (today's Wroclaw), in 1895/96 in Aachen, between 1896 and 1898 in Heidelberg, between 1898 and 1908 in Kiel, and again in Heidelberg in 1910/1911. In 1905 he received the Nobel Prize. He sadly published a textbook "Deutsche Physik" with Nazi positions against Jews.²⁸²²

After 1899, Röntgen as a professor of experimental physics in Munich reorganized the Institute of Theoretical Physics which was losing its importance after Professor Boltzmann's departure. In 1905, Röntgen arranged the appointment of the new professor Sommerfeld, who studied the theory of X-rays as a supporter of Stokes and Wiechert's theory. Four years later the private assistant Laue was employed.

In 1912 in the Hofgarten coffee shop in central Munich Laue defended the possibility of diffraction of X-rays on the crystal at a daily meeting of local physicists. Many doubted Laue's idea. Sommerfeld and Röntgen did not believe that the crystal could act as a diffraction grid because of its thermal motion. The assistant Friedrich set up an experiment in the laboratory half-secretly. He used a crystal of copper (II) sulfate (blue vitriol), which was not lacking in the laboratory. He put the crystal on the path of X-rays, and he installed a photographic plate perpendicular to the crystal, which would allow the detection of X-rays scattered at a right angle after a long irradiation. The rays did not appear because he placed the crystal too close to the source of the rays, just like in his time Röntgen did.

In the same room, P. Knipping was preparing a doctorate; in two or three weeks, he was expected to leave the laboratory. He set up a photographic plate behind the crystal, which brought success. The short report was published in April, and Sommerfeld presented the joint work of Laue, W. Friedrich and Knipping to the Munich Academy on June 8, 1912 (Figure 23-5).²⁸²³

Munich remained the center of X-ray research physics for a decade and a half.²⁸²⁴ In the summer of 1912, W. H. Bragg tried to adjust the Munich experiment to his theory of X-rays imagined as corpuscles. His son Lawrence corrected Laue's analysis of the experiment in November 1912. Under the influence of his father's theory and Stokes's pulse theory, Lawrence assumed that X-rays were particles accompanied by waves. The

²⁸²⁰ Bragg, 1944, 8; Glasser, 1959, 262–264.

²⁸²¹ Wheaton, 1983, 15–17; Wilson, 1987, 203.

²⁸²² Birks, 1963, 27.

²⁸²³ Bragg, 1944, 6; Glasser, 1959, 76; Ioffe (Joffe), 1983, 26, 34–36.

²⁸²⁴ Jungnickel, McCormach, 1986, 276, 278, 285.

Nobel Prize in 1914 was given to Laue, and a year later to the father and son Bragg (Table 23-1).

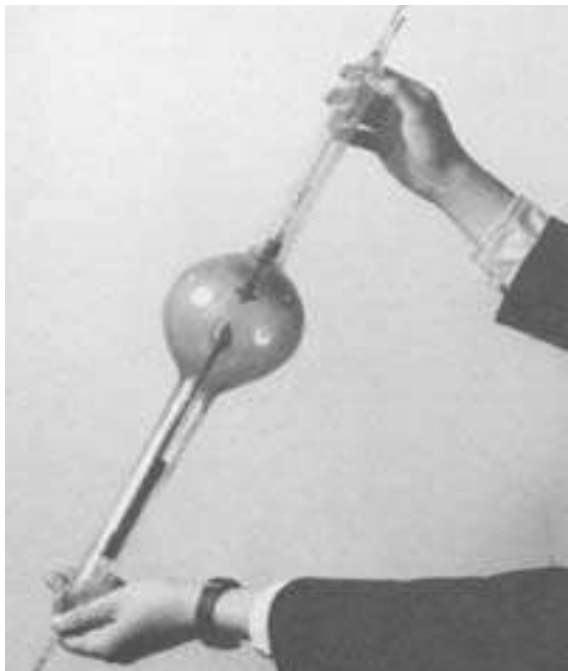

Figure 23-5: Early Coolidge's X-ray tube in 1913²⁸²⁵

Table 23-1: Nobel prizes before the end of the first world War related to X-rays

Year	Nobel lauretes
1901	Röntgen
1905	Lenard
1912	Laue
1913	Bragg, father and son
1917	Barkla

23.6 Notes on Röntgen's Discovery in Habsburg Areas and in Slovenian Countries

23.6.1 On Röntgen's Invention in the German Language of Triestino Mosetig (Mozetič)

The development of new science in Hallerstein's and Vega's time enabled subsequent Carniolan explorers to quickly accept new facts and ideas. It is therefore not surprising that in Ljubljana they wrote about X-rays immediately after Röntgen's discovery. The news was first reported in German

language newspapers, especially in Laibacher Zeitung (LZg), only later in the journal Slovenec. For this reason, for the first time in historiography, we started a study on German written scientific discussions in Ljubljana. For many readers, it will be a great surprise to remember that Slovenian capital was a bilingual city a century ago. Early popular reports and writings about X-rays had an additional charm.

Röntgen's invention has quickly found use outside of physics. On the first day of the new year of 1896, the Viennese professor of physics Franz Exner received the paper of his former classmate Röntgen. He informed his co-worker, a Prague professor of physics Lecher, the son of the editor of the Die Viennese Neue Freie Presse, where they published the news already in the Sunday issue on 5 January 1896. Franz's brother, the physiologist Sigmund Exner, published his report in a Viennese medical newspaper on 16 January 1896.²⁸²⁶

On 12 January 1896, Röntgen was invited to Berlin by the emperor Wilhelm II. The emperor observed many experiments and personally decorated Röntgen's chest with the Prussian order of crown of the second order. Of course, Röntgen was a man who had not succeeded in Matura exam in his time and the gates of all Dutch, German and Austrian universities had been closed tightly to prevent his studies. However, that old youthful scandal was already forgotten, and Röntgen donated to his Emperor twenty-five personally arranged photographs, as the Berliner Localanzeiger accurately reported. Only a few days later, on 15. 1. 1896, the news was published in the LZg, with detailed descriptions of the famous Röntgen without Matura and his Berlin Emperor.

Only one-week after the Viennese, the residents of the town of Ljubljana read about the uses of X-rays in medicine. On 23 January 1896 LZg wrote about two operations of professor Mosetich of Slovenian genus, indeed Albert Johann Mosetig knight Moorhof (Mosetich, Mozetič, 1838 Trieste-1907 in Danube by Vienna) private docent for surgery superior (primarius) of General Hospital. Albert Johann Mosetig knight Moorhof finished his Grammar school in Trieste and studied in Vienna with Brücke and Josef Hyrtl to achieve his PhD in medicine and surgery in the class of his fellow Triestino Johann baron Dumreicher (* 1815

²⁸²⁵ Madey, 1984, 54.

²⁸²⁶ Wien.Klin.Wschr. (Glasser, 1959, 177, 185).

Trieste; † 1880 castle Janušovec northwest of Zagreb near Slovenian border). The general chief physician of the Teutonic Order Mosevig used X-rays to record the position of the projectile in the body and the broken leg of a beautiful young lady. It is interesting to note that even today Slovenians have the leading vacuum technology researchers from the family Mozetič.

— (Röntgen und die Chirurgie.) Im Wiener photographischen Verein wurden diese Tage, wie gemeldet wird, mittelst der Röntgen'schen Strahlen eine Kugel, die seit vierzehn Jahren in der Hand eines Mannes saß, sowie Schrottkörner, die ein Knabe seit Jahresfrist in der Hand hatte, photographiert.

Figure 23-6: Hand surgery after X-ray imaging²⁸²⁷

— (Die Röntgen'schen Strahlen.) Das Pariser städtische Laboratorium stellte Versuche mit Hilfe der Röntgen-Strahlen an, um den Inhalt von Bomben festzustellen. Die Versuche sind vollständig gelungen. Gewisse Explosivstoffe, so knallsaures Salz, chloraurer Kalk, lassen die X-Strahlen nicht durch, während gewöhnliches Pulver und Pikrinsäure durchlässig sind. Man konnte an den photographischen Aufnahmen genau den Inhalt von Bomben an Nägeln, Kugeln, Schrauben u. feststellen und sogar einzelne Pulverkörner wahrnehmen.

Figure 23-7: The Parisian X-rays photo of the inside of the bomb²⁸²⁸

On 27 January 1896, the residents of Ljubljana published Lenard's report from Budapest. Lenard's Nazi career was still awaiting in the future, but at that time he disparagingly described Röntgen's discovery as the accidental success of his lucky rival in an area that he himself mastered to perfection. He tested the permeability of new rays through paper, wood and human hands. At the end of the month, the residents of Ljubljana summarized the Viennese Neue Freie Presse report from the Viennese clinic. Reusser successfully diagnosed kidney stones by his X-rays photographs. The next day, LZg reported X-ray bombardment for the search for a missile, which the man had in his hand for fourteen years (Figure 23-6). On February 2, 1896, a lecture was delivered by Franz Ernst Neumann's Königsberg

²⁸²⁷ LZg. 1. 2. 1896. Tagesneuigkeiten. Röntgen und die Chirurgie. no. 26: 197.

²⁸²⁸ LZg. 7. 3. 1896. Tagesneuigkeiten. Die Röntgen'schen Strahlen. no. 56: 433.

(Kalinigrad) student now professor of physics Jean Pernet (Johannes, 1845 Bern-1902 Zürich) from the Viennese Polytechnic. Four days earlier, he had two hundred and fifty listeners on international days of clinical doctors. He hit the headlines after his experimental X-ray images of a boy's hand. Röntgen was then on a scientific visit to Zurich and sent Pernet the telegrams with heartfelt greetings as Pernet was his former professor of ETH experimental physics where he gave Einstein the lowest possible mark because Einstein was a rare guest in his lab.

The Army also quickly accepted Röntgen's discovery as did physicians themselves. On February 7, 1896, Röntgen's rays were used to check the quality of alloys in pipes and spheres. A month later, the inhabitants of Ljubljana read about the contents of the bomb, which was roentgenized out in a Parisian laboratory (Figure 23-7). They did not mention Curie's spouses, who were married for half a year and participated in the experiments as a leading expert in Parisian metropolitan area. On March 27, 1896, an idle was roentgenized in the right hand of Blanche Mojon (1854-1931), a spouse of the Parisian antisemitic War Minister Godefroy Cavaignac (1853-1905) in a matter of two minutes and the surgeons immediately saved the pain of a famous lady (Figure 23-8). This was the time of the first sewing machines and many careless housewives did not use the right security measures. Boltzmann personally made a sewing machine for his wife, the blue-haired Jetti of half Slovenian descent. Naturally, Jetti was smarter than the minister's lady and avoided harmlessly the supposed damage or injuries.

— (Röntgen-Strahlen.) Ueber einen überraschenden Erfolg, der mit Hilfe von Röntgen'schen X-Strahlen erzielt wurde, wird berichtet: Die Frau des Kriegsministers Cavaignac hatte große Schmerzen durch das Fragment einer Nähnadel, die ihr in die rechte Hand gedrungen war. Die Aerzte vermochten den Sitz der Nadel nicht zu finden. Es gelang nun, mittelst der Röntgen'schen Strahlen in zwei Minuten eine Photographie herzustellen, welche mit größter Klarheit den Platz in der Hand anzeigte, wo die Nadel saß, die nun mit Leichtigkeit entfernt werden konnte.

Figure 23-8: X-ray filming of a needle in the hand of the French minister's spouse²⁸²⁹

²⁸²⁹ LZg. 27. 3. 1896. Tagesneuigkeiten. Röntgen-Strahlen. no. 71: 561.

On 18 February 1896, the LZg reported on the operational removal of needles strapped into the foot and arm of the careless Britons. On February 3, 1896, the inhabitants of Ljubljana summarized the report of the Munich Medicinische Wochenschrift on Hans Buchner's (1850-1902) experiments destroying the bacteria with X-rays. Especially infuriated typhus bacteria had already been successfully suppressed. Thus, the Ljubljana reader of the German language daily learned extremely quickly about all the circumstances of the new discoveries, which justified the subsequent exploration of X-ray in Ljubljana. The discoveries were presented to the German language readers of Ljubljana journal very quickly, only slightly later after the events.

The X-rays were so popular that there was almost no great delay before their descriptions in the imperial city and in the white provincial Ljubljana. In March 1896, the inhabitants of Ljubljana began to publish news about X-rays in Slovenian language magazines.

The opinions of the most important physicist Ludwig Boltzmann determined all other approaches to X-rays in the monarchy and, of course, in Ljubljana. Boltzmann was the best pupil of Slovenian Stefan, and even Boltzmann's bride was half Slovenian. The Carniolan professors of physics discussed all the novelties associated with Röntgen's discovery in due time. Among the writers was Boltzmann's former associate from the University Graz S. Šubic and Boltzmann's student Čadež from Carniolan grammar school; they were especially distinguished. The Čadež's family of Kranj has remained faithful to the X-ray even today.

23.6.2 Slovenian Language Reports on X-rays

Two and a half months after the first publication, X-rays were also described in the Slovenian language. On March 1 and in March 15, 1896, the Ljubljana journal Home and the World (Dom in Svet) published Šubic's first papers on a new discovery with two photographs of J Stefan's student Josef Maria Eder (1855 Krems-1944 Kitzbühel in Tirol), the chair for photochemistry and scientific photography at the Viennese University of Technology. In a series of experiments in 1896, Eder and his father-in-law

Eduard Valenta (1857-1937) managed to drastically improve the newly discovered effect of X-rays on light-sensitive substances within a few days (Figure 23-9). Šubic sent to Ljubljana the beautiful X-rays photos, produced by his colleague at the Graz University Czermak, but they were not published.

Človeško telo — prozorno.

(Spisal dr. Simon Šubic.)

Bilo je na Dunaju prvi mesec po Röntgenovi najdbi nove svetlobe, ko se je setlo več strokovnjakov v delavnici prof. dr. Ederja, voditelja fotografske šole. Učenjaki so se pogovarjali o prevažni odkritvi prodirajoče sile Röntgenovih žarkov.

Pred možmi je stala draga zapletena priprava, sestavljena iz fizikalnih, električnih in fotografskih priprav. V zatemnjeni sobi je stal

In trudil se je prof. dr. Eder in trudil, in poskušali so že mnogi posamezniki in večaki, a večinoma brez pravega uspeha. In zakaj je bilo vse prizadevanje zastonj? Zakaj bi ne mogli s prostimi očmi drugi ogledovati tega, kar je iznajdnik zagledal s svojimi očmi?

Preiskovanje tega vzroka je privlečlo do spoznanja, da senco stvari, obijane od katodnih žarkov, sprejme sicer fotografska ploščica, prosto

Fotografiranje nevidnih stvari.

(Spisal prof. dr. Simon Šubic.)

„Kaj, ali se norčuješ?“ Tako vzkliknejo, miselnih, ogledovalci, katerim pokažem sliko koščice roke, pa pravim, da je to roka živega človeka. Saj to ni čiva roka, poreklo, to so kosti nekdanjega človeka. Čudno me gledate, kaj ne, kako da se ne aramujem tako debele laži? Ostruzeli gledate novo fotografijo; sami ne veste, ali bi se čutili bolj mojemu vkusu, da toliko

tedaj bi fotografiranje ne pokazalo njegovega zunanjega obraza, ki smo ga vajeni, temveč slika bi kazala notranjega človeka, katerega pa v vsakdanjem življenju zakriva razlovednim očem mesena odeja in polt — odkril bi se pred našimi očmi gotovo njegov kosteni koš, morebiti pa tudi njegov drobi, če bi ne zazrli celo njegovih pluć, jeter in srca.

Röntgenova luč in človeško telo.

(Spisal prof. dr. Simon Šubic.)

Med tistim časom, ko je v Monakovem trajal zbor filozofov (životoslovcev), je bilo mnogo dotičnega orodja na ogled razstavljenega v dvoranah fizikalnega zavoda ondanjše univerze. Najzanimivejše je bilo na tej razstavi „Berolinsko električno društvo“

in najzanesljivejše slike na svetlikajočih se zaslonih in na fotografskih tablicah. Njegova nova ustrojitev fotografuje na širših ploščah osebe, ki stojijo dalje od aparata kakor doslej, zakaj Röntgenova svetloba lije s širokim tokom iz Zehnderjeve cevi. Na ta način je

Figure 23-9: Excerpts from the articles of Simone Šubic, published in the period of 1896-1898 in the magazine Dom in svet.

The Slovenian ancestors read about this new discovery a century ago: "This property inspired Röntgen with the idea that the rays of this light do not have the same waves as the ordinary light, i.e. transversal vibration or oscillation in and out perpendicular to direction of light, but it extends by oscillating alongside its direction by longitudinal swinging, that is, back and forth, as the physicist observes in the sound waves."²⁸³⁰ The former priest of Selce by Škofja Loka now Ljubljana cathedral canon Mihael Wurner's high schools student Ivan Sušnik (* 1854 Škofja Loka; † 1942 Ljubljana) supplemented his Poljane neighbor: "Professor Röntgen was dealing with equal experiments. He wrapped the mentioned Hittorf or Crookes tube into a thick, blackened paper completely opaque for the strongest light. A second paper curtain was placed next to the tube,

²⁸³⁰ Šubic, 1896, 186–187, 188.

which was coated with a luminous substance. When a strong induced electric current was introduced through Hittorf's tube, then the mentioned curtain was brightly lit even if that glassy tube was carefully wrapped with opaque paper..."²⁸³¹

Röntgen and his discovery were admired in Slovenian secondary schools. In 1906/1907, the Curator Inwinkl updated his collection in the Cabinet of physics of the Gymnasium Koper with two X-ray tubes. He supplemented them with the third one next year, which also provided a screen from ZnS and preparations for photographing.²⁸³² Under the direction of physicist Senekovič, the Ljubljana gymnasium even more closely followed by new discoveries.

In 1897, during the year of "discovery" of the electron, Stefan's student Ivan Šubic published the first Slovenian book on electricity with an emphasis on electrical engineering, as well as the discovery of new rays. He was a pioneer in technical educations at Slovene countries. He described the experiments with Geissler's tubes and gave a quick reference to X-rays.²⁸³³ More space was devoted to the X-ray by a Ljubljana substitute (suplent) teacher, later Peterlin's professor of physics Fran Čadež: "How this light is exposed to the outside, firstly the doctor (sic!) Röntgen examined in 1895. In a completely dark room, during his experiment, his tube was covered by a completely opaque cloth. Suddenly he observed that all the glass and porcelain vessels in his room began to lighten. Where did the light came from? Soon he was convinced that these rays were coming out of that part of his pipe covered with clothe that was greenish due to the impact of cathode rays..."²⁸³⁴

23.6.3 Sirk's X-Ray Experiments in Ljubljana

The Slovenian reader was kept up to date with Röntgen's achievements. Close cooperation between Viennese and Manchester researchers enabled the Slovenian researchers' understandings of Rutherford's discoveries.

²⁸³¹ Sušnik, 1896.

²⁸³² Inventory Koper, nos.265, 268; Journal of Grammar school (Izvestja Gimnazije) Koper, 1897; 1907, 61; 1908, 56.

²⁸³³ Šubic, 1897, LXIV, 344.

²⁸³⁴ Čadež, 1908, 20.

Professor Sirk of Ljubljana was one of the most important researchers of X-rays and radioactivity in the Habsburg Monarchy. He was of Slovenian own genus, but he never become fluent in Slovenian language. He completed his reputation in Ljubljana as one of the most important X-ray researchers in the monarchy. On March 23, 1934, he published a study of the magnetic effects of scattering of X-rays in a liquid that brought the name of the University of Ljubljana into the very top of science (Figure 23-10). He continued the work of Parisian M. de Broglie, the older brother of Nobel laureate Louis, who lectured at the Collège de France until the end of the Second World War. In 1913 Maurice first studied the influence of steel and magnetite on X-rays.

Der Einfluß eines Magnetfeldes auf die Streuung von Röntgenstrahlen in Flüssigkeiten.

Von H. Sirk in Ljubljana.

Mit 3 Abbildungen. (Eingegangen am 23. März 1934.)

Es wird der Einfluß eines $4 \cdot 10^4$ Gauß starken Magnetfeldes auf die durch Streuung in α -Chlornaphthalin entstehenden Debye-Scherrer-Ringe durch photometrische Registrierung untersucht. Es zeigt sich keine Andeutung einer Faserstruktur. Mit Rücksicht auf die mit $\pm 10\%$ geschätzten Fehlergrenzen des Verfahrens wird eine Grenze für die Anzahl der Molekeln in einem „Pakete“ schätzungsweise mit 10^4 angegeben.

Figure 23-10: Sirk's Ljubljana Discussion on Magnetic influences on X-Rays²⁸³⁵

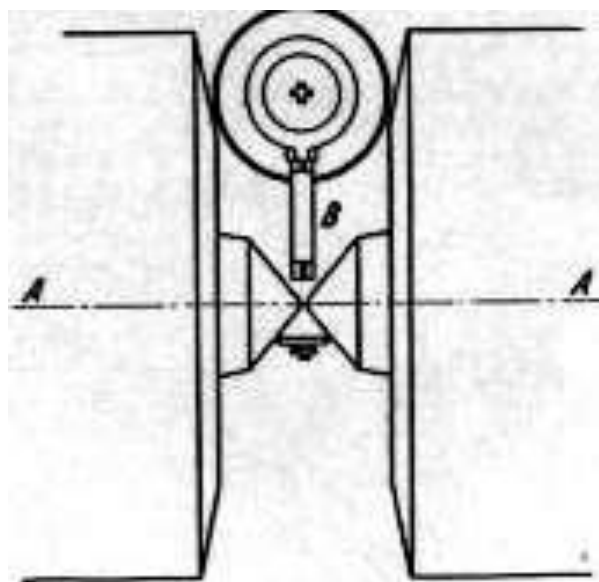

Figure 23-11: Sketches of Sirk's and Peterlin's X-ray tube of Carl Heinrich Florenz Müller (1845-1912 Hamburg) from Hamburg²⁸³⁶ whose C.H.F. Müller Röntgenwerk collaborated with Philips

²⁸³⁵ Sirk, 1934, 129.

²⁸³⁶ Sirk, 1934, 133.

wählten oberen Grenze erscheint nur möglich, wenn es gelingen sollte, stärkere Magnetfelder anzuwenden und die zentralen Asymmetrien in den abgebeugten Debye-Scherrer-Kegeln genauer zu untersuchen, als es die Photometrierung photographischer Aufnahmen gestattet.

Die lichtelektrischen Registrierungen der Filme wurden mit dem Zeiss-schen Registrierphotometer der graphischen Lehr- und Versuchsanstalt in Wien ausgeführt. Es ist mir eine angenehme Pflicht, der Leitung der genannten Anstalt, insbesondere Herrn Fachvorstand Prof. Krumpel für die freundliche Überlassung des Apparates und Herrn Dr. A. Stiegler für seine Hilfe bei Ausführung der Registrierungen aufrichtig zu danken.

Bei Ausführung der Versuche wurde ich von meinem Assistenten, Herrn Peterlin, auf das Wirksamste unterstützt, wofür ich ihm hier meinen Dank ausspreche.

Ljubljana, Physikalisches Institut der Universität.

Figure 23-12: Sirk thanked his assistant Peterlin²⁸³⁷

Sirk was assisted by Peterlin at the Ljubljana Institute. They measured multi-atomic large molecules, which soon became Peterlin's basic research field.²⁸³⁸ Since 1930, the X-ray tube of the most famous Hamburger producer C. H. F. Müller was used at the Ljubljana Physics Institute (Figure 23-11).²⁸³⁹ At the end of his paper Sirk warmly thanked his assistant Peterlin (Figure 23-12),²⁸⁴⁰ who soon independently published a lot in the same leading Berlin magazine. Peterlin later took over the Physical Institute, which after the war worked within the Academy and grew into the Physical Institute, today's IJS. Peterlin's early interest in X-rays paved the way to his initiatives for introducing accelerators to the new Ljubljana Physical Institute a decade and half later.

23.6.4 Conclusion

Ljubljana residents read their domestically published news about X-rays without major delays. This is not surprising, and it only proves the capability of Carniolan people and its diverse inhabitants who chased the wind of knowledge from the Italian, German, Hungarian and Slavic sources to use the best among them. Of course, the Slovenian researchers had to wait for the development of university laboratories after the First World War. Sirk's work was the beginning of a long series of triumphs today associated with the IJS. The success of X-ray research was crowned by the start of PIXE surveys at the IJS almost immediately after the Swedish discovery in the

1970s. Experts from the IJS have been involved in research with the PIXE method practically from the very beginning on the initiative of prof. dr. Bogdan Povh and dr. Peter Kump. The blossoming of PIXE was based on the development of semiconductor X-ray detectors. At that time, they already achieved high enough energy resolution, so that it was possible to distinguish between characteristic X-rays belonging to individual elements. On the other hand, at that time, the accelerators developed for research in nuclear physics began to be abandoned, as the center of mainstream research shifted to higher energies. Accelerated energy ions of several MeV are precisely the appropriate tool for the ionization of internal atomic shells; so, PIXE researchers took them over from nuclear physicists at the IJS.²⁸⁴¹

²⁸³⁷ Sirk, 1934, 142.

²⁸³⁸ Sirk, 1934, 130, 139.

²⁸³⁹ Sirk, 1934, 132.

²⁸⁴⁰ Sirk, 1934, 142.

²⁸⁴¹ Information from dr. Miloš Budnar.

24 Major Scientific Uses of Vacuum Technologies: Electrons

24.1 Thomson's Research of Negative and Positive Rays

24.1.1 "Cathode rays"

X-rays might have been the outcome of continental obsessions with waves (of seas), while the Brits encircled by seas followed their own preferred particles trapped in their inherited linguistics which uses the same word for lightweight and for the lighting. We'll present a wider range of J.J. Thomson's vacuum research, his major and lesser successes. We will show that the "discovery" of the electron was only one of his many breaking successes.

24.1.1.1 Thomson's Career Path

Joseph John Thomson (Figure 24-1) was born into a bookshop family in Cheetham, a northern suburb of Manchester. He attended Owens College in Manchester, where Stewart taught him physics, after he tutored the Scotsman Tait and the German Schuster before Thomson.²⁸⁴² Manchester was already an important center of physics and of Engels' personal observations of deprived working class published a dozen years before the birth of Engels' Manchester neighbour J.J. Thomson.

After his Manchester beginnings, Thomson continued his studies under supervision of the professor Stokes at the Trinity College in Cambridge between 1876 and 1880. During this time Maxwell was already boss of the Cavendish Laboratory. Thomson never met Maxwell in the lab, but he listened to his lecture about the phone in the senate house in 1879. Thomson won the honour of second wrangler behind later glorified English physicist Larmor, who was also a professor in Cambridge since 1903. In 1881, Thomson was elected to the College of St. Trinity, with which he remained connected all his life. The

following year, he received the Adams Prize for exploring the vortices in ideal fluid, and later became interested in similar vortexes needed for his models of the atom. At that time, he published some inaccurate electrical charge measurements. After short work in Cavendish under Rayleigh's leadership, when JJ Thomson excelled primarily by his theoretical researches, he relatively surprised the community when he was elected as the Cambridge professor and the third director of Cavendish's labs after Maxwell and Rayleigh in 1884. He retained the position for 28 years. J.J. Thomson's early experimenting might not be that clumsy as W. Pauli's or Peterlin's.



Figure 24-1: J. J. Thomson (* 1856; † 1940).

During 1905 and 1918 he was a professor at the RI, and after 1919, he was the head of the College of St. Trinity. He became a fellow of the RS in 1884 and its president between 1916 and 1920. In 1906 he received the Nobel Prize for the study of the "passage of electricity through gases", and he was knighted in 1908. During the First World War, he was a technical adviser to the government. He was buried in the Westminster Chapel near Newton, like his student Rutherford after him.

24.1.1.2 Thomson's Predecessors

The idea of the existence of an elemental electric charge or "electrical atom" was already described by American Benjamin Franklin in the 18th century: "The electrical substance consists of very small particles, as it can penetrate even into the densest substance with such freedom and ease that it does not feel greater resistance." Similar ideas were also published by the Italian Mossotti, the

²⁸⁴² Fox, Guagnini, 1999, 120.

Englishman Davy, the German Weber in 1871 and others. Faraday supported the assumption of an elementary electric charge by his discovery of quantitative electrolysis laws.²⁸⁴³ Franklin's friend Bošković also described all sorts of small particles as the most of people believed that every substance consists of smaller ones after the discovery of microscopes.

So, both assumptions about the nature of cathode rays appeared almost simultaneously, and for almost three decades they initiated antagonism which was in many ways nationally and linguistically determined with the English language users preferring particles because of the similarity of English language terms lightweight and solar light. In 1888, in addition to the Slavic

From 1872 to 1878 **Eugen Goldstein** of Gleiwitz, today's Gliwice in Polish Silesia, researched at the University of Berlin at Helmholtz's class, and then he worked in astrophysics at the Berlin Observatory in Potsdam until 1890. In 1876 he coined the term "cathode ray", and five years later he received a doctorate in Berlin. Until 1896 he worked at the Physics and Technology Institute and then at the Higher Technical School in Berlin until his retirement in 1927.

There was much less consensus on the nature of "cathode rays". In 1876 the name was invented in Berlin by Goldstein, when his point cathode was replaced by a plate from which the rays flew in a rectangular direction. In 1869 Hittorf assumed that the "cathode rays" were waves like light which wave nature was almost not doubted any more after Fresnel and Young's research, although some Brits like Brewster still relied on Newtonian approach. However, two years later, Varley described the "cathode ray" as a small charge of particles: "This experiment, according to the author's opinion, shows that the arc is composed of charged particles of matter, which electricity break in all directions out of the negative electrode..."²⁸⁴⁴



Figure 24-2: The first page of Perrin's manuscript of the dissertation *Rayons cathodiques et Rayons de Röntgen* in 1897²⁸⁴⁵

As a telegraph engineer, **Cromwell Fleetwood Varley** advised W. Thomson, later Lord Kelvin, how to lay the telegraph cable in the deepness of Atlantic between 1856 and 1866. In 1870 he was half-retired when the British government nationalized private telegraph companies. So, he suddenly had enough time to explore the "cathode rays". Like Crookes, he dealt with spiritism, which in those Victorian times somehow stimulated particles over waves in Newtonian spirit.

guys Šubic in Graz and Puluj in Prague,²⁸⁴⁶ the wave theory of cathode rays was defended mainly in the Helmholtz's Berliner Circle including Goldstein and E. Wiederman in 1880, and H. Hertz in 1883-1892. With Perrin's experiments (1895), the corpuscular theory of mostly British researchers prevailed (Figure 22-4). It attracted Varely (1871), Crookes (1878-1879), the Fulda Grammar school professor and deputy rector retired in 1882 Wilhelm Gies (1813 Neustadt by Magdeburg in Hessen-1891) in 1885, and Schuster

²⁸⁴³ Millikan, 1963, 15.

²⁸⁴⁴ Vjalcev, 1981, 41; Dahl, 1997, 61.

²⁸⁴⁵ Célébration du centenaire de la naissance de Jean Perrin, Presses Universitaires de France, Paris 1971, 13.

²⁸⁴⁶ Puluj, 1889, 305.

(1882, 1884).²⁸⁴⁷ Helmholtz himself, as the leading scientist with lot of international connections occasionally switched his supports from one group to another.²⁸⁴⁸

Jean Baptiste Perrin of Lille studied at the École Normale Supérieure and in 1897 he received a doctorate with a dissertation on cathode rays and X-rays. He then studied at the University of Paris Institute and was appointed Professor of Physical Chemistry in 1910. Between 1908 and 1913, he experimented to support Einstein and Smoluchowski's theory of Brownian motion. Prior to the First World War, he also visited Rutherford's Laboratory in Manchester. In 1926 he received the Nobel Prize in Physics "for his efforts to explore the structure of the substance and, above all, to discover the sedimentation equilibrium." As an active Anti-Fascist, he had to move to the US in 1938, where he supported Charles de Gaulle's struggle. He died in New York.²⁸⁴⁹

In 1882, Helmholtz's most important student, H. Hertz, found that "cathode rays" resembled the light. In his early experiments he seemingly proved that the electric field does not affect them.²⁸⁵⁰ Later, it turned out that he did not notice the deflection because he placed his metal capacitor with a distance between the plates of 2 cm and a voltage of 22 V or 500 V outside his tube. This caused the reverse electrical current and overshadowed the effect of the field.²⁸⁵¹ In addition, he used the excess pressure in the discharge vessel. Because of the incorrect explanation of his experiments Hertz and many other German researchers for over a decade mistakenly believed that "cathode rays" were related to electricity only by their genesis, like light is related to an electric bulb which was popularized in Edison's version in those times.²⁸⁵² The electricity tend to produce light, but no identity among them was adequately promoted before Maxwell's work published in 1873.

Heinrich Rudolf Hertz was the oldest son of a lawyer, a later senator of the Jewish genus in Hamburg. Hertz was a part of huge wave of secular Jews who suddenly got their equal rights in central Europe and quickly proved their excellences like Karl Marx. After his graduation in 1875, Hertz first studied engineering in Munich for two years and, in the meantime, served a military term in new German state army for a year. Then he changed his mind and continued his studies of mathematics and natural science in Munich. In 1879 he completed two semesters at Kirchhoff's class in Heidelberg and in Berlin, where he studied at the Helmholtz's Institute. On 5 February 1880, he completed his magna cum laude study with a theoretical research of the rotation of metal balls in a magnetic field. During his research in Helmholtz's group in the following years, he was heavily influenced by seven-year-old Goldstein. In 1883, Hertz became an assistant professor at the University of Kiel. On the Helmholtz's recommendation, in the winter of 1884, Hertz succeeded Braun as a full-time professor of experimental physics at the Technical College in Karlsruhe, where he researched a photoelectricity and first detected electromagnetic waves with a transmitting dipole resonator and a receiver consisting of a loop antenna and spark gap. In 1889, he took over the Department of Physics after the death of Clausius in Bonn. Hertz died of cancer after prolonged illness infected because he carelessly used Clausius's room which previously served as a hospital. In the year before his death, Hertz wrote a book on the principles of mechanics (1904) in the Neo-Kantian spirit without the concept of force, unfortunately, without much influences on later researchers.

When the deflection of "cathode rays" in the magnetic field was finally proved beyond doubt, it was explained by deformation of "ether". Their spreading exclusively in the rectangular direction relative to the surface of their source was attributed to the special useful features of the formation of "cathode rays" associated with electricity. In 1880, Goldstein even proved that the spread of cathode rays was taking place in different directions. However, in 1906 J. J. Thomson showed that cathode rays deviate from their perpendicular directions to the surface of the source only after the

²⁸⁴⁷ Filonovič, 1990, 151; Puluž, 1889, 305.

²⁸⁴⁸ Dahl, 1997, 80.

²⁸⁴⁹ Robinson, 1963, 56.

²⁸⁵⁰ Hurd, Kipling, 1964, 344; Weinberg, 1986, 52; Wien, 1987, 292.

²⁸⁵¹ Anderson, 1968, 46–47.

²⁸⁵² Filonovič, 1990, 151; Vjalcev, 1981, 42.

emission, under the influence of an electric field, or due to scattering.²⁸⁵³

For the advocates of the corpuscular model of cathode rays, their linear propagation was the fundamental problem although it looked very natural. In 1891 and 1892, Hertz additionally found that cathode rays could penetrate a thin layer of gold, silver, aluminium and various alloys, which could not be attributed to the then known types of particles.

In 1880, Tait and after him Goldstein argued that Crookes's supposed molecules at high velocities in cathode rays would have to change the wavelength of radiation due to the Doppler effect. However, no changes were observed in their measurements.²⁸⁵⁴ The astronomers later observed similar phenomenon on celestial bodies as a redshift.

24.1.1.3 Thomson's Contemporaries

J.J. Thomson and his senior colleague from their students' days in Manchester Schuster simultaneously began exploring discharges in gases in 1883/84. However, Schuster wished to resolve that problem as a spectroscopy chemist and J. J. Thomson researched the same problems as a mathematical physicist. In 1884 and 1887 they were successively appointed new leaders of the most important British physical laboratories in Cambridge and in Manchester. Schuster was influenced by both English and German scientific traditions. He advocated the existence of a particle of electricity to put Faraday's electrolysis in agreement with Maxwell's theory of electromagnetism. He referred to Helmholtz's ideas summarized by Stoney: "Electricity is also some kind of fine matter, made up of the smallest atoms - electrons".²⁸⁵⁵ However, he did not follow Maxwell's advocates, but rather preferred the model of his friend, chemist and astronomer Lockyer, who discovered the yellow line of helium in the spectrum of the Sun in 1869. According to Lockyer, the complicated dissociation of molecules in gases causes the complexity of their spectra. Schuster wanted to prove that every particle of gas carries the same amount of electricity that would allow the applications of Faraday's electrolysis

laws in the gases.²⁸⁵⁶ The concept of charge of electron as the smallest amount of electricity was born, although it was not yet connected with any named particle.

Unlike J. J. Thomson, Schuster was not interested in the size of the electricity particles and the nature of the "cathode ray". The contradictions between the researchers were partly the result of the old contradictions between the dual-fluid (Schuster) and the one-fluid (Thomson) model of electricity.

In 1884, Schuster continued Hittorf's experiments with the "cathode ray" deflection in the field. In such ancestor of the cyclotron, the radius of curvature of the particle's track was determined by its e/m ratio.

Six years later Schuster measured the ratio e/m of "cathode rays" and got a result between 1000 and 1,000,000 "electromagnetic units" per 10,000 As/kg. For hydrogen ions, this ratio was 10,000, both in gas and in the electrolyte. For Schuster exactly the highest measured value, i.e. 1,000,000, did not seem real because it requires a passage of a "particle" through a cathode-ray tube without a collision. By doing so, he eliminated his own correct measurement and, with it, a quick discovery of the "electron". Schuster erroneously expected an e/m ratio in gases of similar sizes than in electrolysis. Schuster's gas-carriers were unfortunately expected to be the ions which was, of course, a general misconception before J. J. Thomson's paper of 1897. The ions are at least few thousand times heavier than the electrons which were about to be "discovered". In addition, Schuster was not searching for the "electron" or the nature of "cathode rays," but he focused on the validity of Faraday's electrolysis laws; he did not compete with Thomson's discovery, and in 1895 he finally stopped exploring discharges in gases altogether.²⁸⁵⁷

24.1.1.4 Discovery: Measurement of e/m ratio for "Cathode Ray"

J. J. Thomson also initially argued that the laws of electrolysis are valid in gases, as the liquids and gases supposedly translated electricity in the same way. However, in 1891/92 he had to abandon that

²⁸⁵³ Anderson, 1968, 36–37, 39.

²⁸⁵⁴ Frisch, 1972, 55; Laue, 1969, 310–311; Anderson, 1968, 36, 39, 48–49.

²⁸⁵⁵ Laue, 1969, 313; Derganc, 1917, 102.

²⁸⁵⁶ Dahl, 1997, 102–104.

²⁸⁵⁷ Feffer, 1989, 33–34, 39–52; Andreson, 1968, 41.

idea. Only upon the very long sparks in the cathode-ray tube during the electrolysis of water vapor the substances are deposited on the same electrodes as in the electrolysis of water.

At the end of the 19th century, Thomson supported Crookes's ideas from 1874 about the cathode rays as the basic particles of the atom. However, as early as 1894, Thomson and other contemporaries saw ions of gases in their cathode rays.²⁸⁵⁸ Only Lenard's measurements from 1893 showed that "cathode rays" have an average free path in the air of about 1 mm, which is about 10,000 times longer than molecules. The result convicted Thomson that he was dealing with much smaller particles than the lightest atom, which of course did not please everyone. In those times the researchers still knew some classical Greek language where any talk about divisible atoms sounded just like nonsense, resembling the funny concepts of vacuum in Latin language. To believe in vacuum and in particles smaller than atoms, the European people had to forget their eventual education in classical languages.

Thomson and the young Perrin (1895) had the deflection of cathode ray in the electric and magnetic fields for their essential characteristic, for their decisive experiment. The cathode rays were declared for long-sought electrons precisely because of their electric charge, whose ratio to the mass Thomson measured in 1897. The measurement was in perfect harmony with the English tradition, where Crookes immediately declared the "discovery" of electrons to confirm their own vision of the fourth aggregate state of the substances.²⁸⁵⁹

Thomson regarded and treated the penetration power of cathode rays in the substance as their less important feature. He suggested that the cathode rays in the substance cause secondary X-rays, which then penetrate further. In contrast to Crookes, Schuster and other English researchers, Thomson was not interested in the form of illumination in the Geissler tube nor in the analogy between chemical reactions in electrolysis and reactions in the vacuum cathode ray tube.²⁸⁶⁰ Those puzzles belonged to the first generation of

researchers of cathode ray tube invented in the time of Thomson's birth.

In 1894, Thomson measured the rays β (cathode rays), which were accelerated at a speed of 200 km/s; but later he refused his own results as inaccurate.²⁸⁶¹ Three years later he was able to measure the deflection of the rays β (cathode rays) in the electric field because he used better vacuum pumps than the late Hertz did; although did not have the best vacuum equipment and tools for degassing in Cavendish labs even after the First World War they.²⁸⁶² A similar success was achieved at the same time by Goldstein.

Thomson used Töpler's pump and Crookes's method for the removal of vapours of mercury with phosphorus or copper. In March 1897, he deflected electrons (cathode rays) with a transverse magnetic field, and then compensated the deflection by an electrostatic field of a flat capacitor with aluminium plates. He sent his rays through air, hydrogen or CO₂ at a low pressure 5 cm away into the electric and magnetic fields. The distance to the screen was an additional 1.1 meters. He obtained m/e ratio 10⁻⁷ "electromagnetic units" of 10⁻¹¹ As/kg. His result was more than a thousand times smaller than the results obtained for hydrogen ion in electrolysis and depended on the nature of the gas, the type of cathode, the rate of light and the pressure in the cathode ray tube. In his experiments Thomson changed iron, platinum and aluminium electrodes. He did not record his measurement errors as it was not a necessity by that time, but today his experimental error is estimated at 14%.²⁸⁶³

Thomson presented his discovery in the RI lecture on 30 April 1897, and the following month he published it in leading English magazines. His quickly arranged publications prevented any possible independent discovery in other laboratories. The results reminded him of Prout's assumption. However, Thomson's substances were not hydrogen atoms, but a much smaller structure nicknamed "corpuscle". He wrote the claims that resemble Crookes's ideas because they both worked in similar networks: "From this point of view, in the cathode rays, we have the substance in

²⁸⁵⁸ Vjalcev, 1981, 49.

²⁸⁵⁹ Wilson, 1987, 205.

²⁸⁶⁰ Feffer, 1989, 58, 61.

²⁸⁶¹ Vjalcev, 1981, 49–50.

²⁸⁶² Weinberg, 1986, 44; Badash, 1987, 358.

²⁸⁶³ Feffer, 1989, 58; Thomson, 1964, 354, 357; Anderson, 1968, 53; Weinberg, 1986, 82, 85.

a new state, in which the division of matter goes much further than in ordinary gas: the state of that (cathode ray) matter obtained from various sources such as hydrogen, oxygen, is of a single species. This substance is a substance from which all chemical elements are built. The mass of the substance obtained by dissociation on the cathode is so small that almost excludes any possibility of direct chemical research of its properties. If the used coil would let it work day and night all year, it would, in my calculations, produce only about 3 trillionth part of a gram of this substance."²⁸⁶⁴ Evidently, Thomson still considered that he is researching a special kind of chemical element, in fact a small ion. He changed his mind very soon as there was no place for his corpuscle in Mendeleev's table of chemical elements.

Thomson described the atom as a set of small particles; among which Bošković force of variable direction works, which he defended even later.²⁸⁶⁵ He additionally proposed a different atom, according to Regnault's Parisian student Alfred Marshall Mayer, a professor at the Stevens Institute of Technology in Hoboken NJ in USA. In 1878, Mayer described an experiment with magnets geometrically arranged to float of the water, balanced with an external magnetic field and interacting with each other. However, FitzGerald, the pioneer of television Campbell-Swinton and most British researchers "rejected too much alchemy" involved in the supposition of Thomson; Rutherford's jokes put up with alchemy a few years later.²⁸⁶⁶ In fact, alchemy was no more a taboo which crippled alchemy from centuries including its Newtonian era.

Thomson used a different method for determining his e/m ratio by measuring the heat produced by the cathode rays on the wall of cathode ray tube.²⁸⁶⁷ Most physicists did not believe in Thomson's discovery of particles smaller than the atom, although he referred to a year-long measurement of the ratio e/m of the Dutch spectroscopist Zeeman, Lorentz's assistant in Leyden. Zeeman continued the very last Faraday's experiment conducted on 12. 3. 1862, in which he tried to influence the yellow line of sodium with a

magnetic field. Faraday was convinced that a successful measurement could be done, while Larmor doubted it. Zeeman certainly thought that it would be worth pursuing where his famous predecessor finished his researches. Certainly, Zeeman was able to obtain much better equipment including the famous Rowland's high quality of the diffraction gratings with much higher resolution than the Faraday's spectroscope on prism, a better vacuum pump, and a stronger magnet. Zeeman, due to the wrongly defined axis of the $\lambda/4$ -plate, published the result for a positive charge instead of a negative one. His debut was published in March 1897 in *Phil. Mag.*, one volume before Thomson's "discovery." Lorentz's theory supported the results of his assistant therefore they shared the Nobel Prize in Physics in 1902.²⁸⁶⁸

Pieter Zeeman was born in a small village of Zonnemaire on the island of Schowen, in the province of Zeeland, in the Netherlands, in the family of a Protestant pastor. His High School Gymnasium paper was good enough to be published in the journal *Nature*. His teachers were mostly Lorentz and Kamerlingh-Onnes at Leyden University. In 1892, he studied one semester at Kohlrauch's lab in Strasbourg, and in 1894 he returned to Leyden as a private assistant professor (docent). In January 1897 he became a lecturer at the University of Amsterdam and remained there until his retirement in 1935. In 1908 he succeeded van der Waals as a professor and director of the Physics Institute in Amsterdam.

Thomson first realized that he was breaking atoms in his experiments. In good old English Newtonian and Crookes' traditions he declared the cathode rays as corpuscular matter, which he considered as particles in Newtonian classical mechanics.²⁸⁶⁹ The assumption was completely different from the theory of "ether." Like Hertz (1888), Einstein (1905), and others, Thomson preferred to emphasize the connection of his discoveries with Maxwell's theory while he tried to diminish the differences in their description of the structure of the "ether" and of the electricity.²⁸⁷⁰ Tesla might

²⁸⁶⁴ Thomson, 1964, 358, 359–360; Vjalcev, 1981, 58, 72–73.

²⁸⁶⁵ Thomson, 1907.

²⁸⁶⁶ Thomson, 1964, 361–362; Vjalcev, 1981, 83; Lelong, 1997, 105; Darrigol, 1998, 28; Dahl, 1997, 325.

²⁸⁶⁷ Weinberg, 1986, 85.

²⁸⁶⁸ Vjalcev, 1981, 73, 77; Weinberg, 1986, 99–100; Dahl, 1997, 9, 197.

²⁸⁶⁹ Thomson, 1964, 341.

²⁸⁷⁰ Cazenobe, 1984, 972–986.

have thought that ether and electricity are nearly the same, but Thomson or Einstein preferred different opinions.

Thomson showed that radiation and translation in gases cannot be explained by the waves themselves. Thomson's "corpuscles" finally got the name which Stoney coined: "In the electrolysis of each chemical compound we can separate in all cases the same quantity of electricity... The charge of that size is bound in every chemical atom ... These charges, which we will call 'electrons', cannot be separated from the atom; they do not show if the atoms are chemically bound". In 1897, FitzGerald and Lorentz introduced the term electron in physics.²⁸⁷¹ Wiechert supported Lenard's expression of the "quantum" of elemental negative charge; however, Planck's application of the term quantum was used in a different sense soon enough.²⁸⁷²

Stoney was thinking about the atomic structure of electricity already in his lecture before the British Association for the Advancement of Science (BAAS) in 1874, which he published only seven years later.²⁸⁷³ Based on Faraday's electrolysis experiments, he approximately determined the charge. Faraday thought about the atomic structure of electricity and he was followed by Crookes. J. J. Thomson opposed Larmor's and FitzGerald's theory of electrons in several discussions, including in his criticism of Australian Sutherland. He considered that there was no evidence of the existence of a charge outside the substance. He preferred the assumption of "corpuscles" as the structured building blocks of the atom, although it was also impossible to prove the partition of the atom. He did not treat the "corpuscle" an independent particle, but as an interaction between ether and matter. Therefore, Thomson first used the term "electron" only in 1937, much later than his students Townsend (1915), Langevin (1904) and others. Even his opponent Villard accepted electron earlier, as Villard used the term at the Parisian Academy after 1908.

On the other hand, Thomson might have wanted to avoid confusion; unlike his younger colleagues, he

remembered well that Stoney used the term electron as a unit of charge of both signs and not for the material particle.²⁸⁷⁴ The vocabularies were shaped by the gaps between generations, while their terms were by no means unimportant.

The mysterious "cathode rays" soon got no less puzzling siblings. In 1899, Lenard and Thomson measured approximately the same e/m ratio obtained for "cathode rays" also in other circumstances including the particles in the photoelectric effect, and in the "Edison effect" of the thermal electron emission from glowing metallic surfaces. Becquerel received the same result for rays β from radium a few months later.²⁸⁷⁵ As with all major discoveries, Thomson was fully established only with the print of the book and the influence of his students outside his home country, especially in Paris.²⁸⁷⁶ Nobody is a prophet in his homeland.

24.1.1.5 Thomson's Successors

Wiechert developed an etheric version of Helmholtz's atoms in Königsberg (today's Kaliningrad) in 1894. Two years later, together with Theodor Des Coudres, they measured the speed of cathode rays. On 7 January 1897, Wiechert announced that cathode rays had a 200 to 2,000 times greater e/m than hydrogen ions, and thus envisaged an independent particle. However, Wiechert was only a beginner in the study of "cathode rays" and in addition he published his measurements at the local journal in Königsberg, just like much more successful Röntgen did in Würzburg in 1895. In 1897 and 1898, other Germans and British, especially Thomson, Schuster and Wien, published measurements of high-speed "cathode rays".²⁸⁷⁷

Simultaneously with Thomson, Kaufmann²⁸⁷⁸ compared the e/m ratio in similar experiments in Berlin on 21 May 1897. He did not claim to be discovering a "new corpuscle," since such a claim in the German environment would have been even sharply rejected because of the dominant influence of the positivist Mach, whose parents lived in

²⁸⁷¹ Filonovič, 1990, 148; Stoney, 1894, 418–420; Weinberg, 1986, 106; Darrigol, 1998, 20.

²⁸⁷² Lenard, 1905, 398, 400–402, 412–414; Lenard, 1905, 416; Darrigol, 1998, 5–6.

²⁸⁷³ Stoney, 1881, 381–390; Millikan, 1963, 22.

²⁸⁷⁴ Feffer, 1989, 59–61; Lelong, 1997, 107–108, 110, 124; Millikan, 1963, 25–27; Dahl, 1997, 188.

²⁸⁷⁵ Weinberg, 1986, 103; Vjalcev, 1981, 65.

²⁸⁷⁶ Lelong, 1997, 115–116.

²⁸⁷⁷ Darrogol, 1998, 20, 25–26; Vjalcev, 1981, 53–57, 72, 75.

²⁸⁷⁸ Dahl, 1997, 156.

Lower Carniola (Dolenjska).²⁸⁷⁹ At that time Mach excited the supporters of the atoms with the provocative question: "Have you seen them?"²⁸⁸⁰

The German **Walter Kaufmann** studied in Berlin and graduated in Munich. Between 1896 and 1898 he was an assistant at the University and at the Physical Institute in Berlin. Between 1897 and 1899, he additionally worked as a librarian of the German Physical Society in Berlin. In 1899 he went to the University of Göttingen, where Des Coudres also studied the effect of the magnetic field on "cathode ray". In 1903, Kaufmann switched to Bonn University, where he also assembled the first high-vacuum rotary pump before Gaede. Due to the excellent knowledge of vacuum technology, he had some advantages over Cavendish lab researchers. Between 1908 and 1935 he taught in Königsberg, but he did not research "cathode rays" anymore.

Similarly, Mach's contemporary Mendeleev in his dissertation of 1857 described atomism only as a useful explanation in contrast to the theory of waves or to Copernican theory. An entirely different point was the English position, illustrated by Rutherford's exclamation answering Eddington's statement after dinner at Athenaeum club of London. The Quaker Eddington noted that the electrons may be just conceived concepts and do not really exist. The tall New Zealand native rose up in all his great length and shouted: "Not exist, not exist - why I can see the little beggars there in front of me as plainly as I can see that spoon?!"²⁸⁸¹ The discovery of the electron was largely due to the national characteristics of the research environments, since British physicists performed much more extensive measurements of electric charges, while the Germans published much more theories about them.²⁸⁸²

In 1901 Kaufmann proved that the apparent (electromagnetic) part of the masses of Becquerel's fast electrons from radioactive substances is increasing with their velocities. Abraham supported that result with calculations in his first hypothesis about the structure of an electron

²⁸⁷⁹ Weinberg, 1986, 104.

²⁸⁸⁰ Brush, 1976, 875.

²⁸⁸¹ Birks, 1963, 39; Badash, 1987, 354.

²⁸⁸² Vjalcev, 1981, 26–27, 51–52, 74.

imagined as a solid sphere with evenly distributed charges. For some time, Kaufmann's results were used against the theory of relativity, and then they were corrected by more accurate measurements.

On 1 April 1889, **Johann Emil Wiechert** became assistant professor of mathematical physics at the University of Königsberg. With his later celebrity student Sommerfeld, who was promoted in mathematical physics in 1891, they designed their harmonic oscillator. In 1897, Wiechert went to the University of Göttingen and Sommerfeld went to the nearby Clausthal-Zellenfeld, where they continued their cooperation. In the following years, the Jewish Herman Minkowski's son-in-law Wiechert was involved in geophysics.

Max Abraham from Danzig (today's Gdansk) graduated from the University of Berlin in 1897 and worked there as Planck's assistant. Between 1900 and 1909 he was a professor in Göttingen. Until World War I and afterwards he taught in Milan, then in Stuttgart and Aachen.

Paul Ulrich Villard from Lyon started studying at the École Normale Supérieure in 1881, where he decided for physics three years later. He taught at various Lyceums outside of Paris, most recently in Montpellier. He then came to the Chemistry Laboratory of Henry Jules Debay at the École Normale Supérieure as a freelance researcher. Between 1906 and 1908, he published the theory of the northern light (Aurora Borealis), and then he became a member of the Parisian Academy on 21 December 1908.

In 1897, Villard²⁸⁸³ abandoned the research of physical chemistry and began to study the "cathode rays". Unlike J. J. Thomson, the electrical charges of cathode rays were of less importance for Villard, while he mostly studied their chemical characteristics. The following year he described cathode rays as hydrogen ions because he wanted to avoid the "unnecessary" introduction of a new type of particles. The idea contradicted both the

²⁸⁸³ Lelong, 1997, 92, 121.

British "corpuscles" and the German "waves" with the electron included. So, the Frenchman Villard was left alone.

During 1899 and 1900, Villard discovered the rays γ , which were initially named after him. He described his claims at the first International Congress of Physicists in Paris between 6 and 11 August 1900, at the reception of the Parisian Academy of Sciences on December 19, 1904 and especially in Abraham's and Langevin's Proceedings of 1905, where two thirds of the discussions were written by JJ Thomson and his disciples. Villard did not have the support of younger Parisian researchers who published in *Le Radium* after 1905 and joined the *Journal de physique* after 1918. Villard abandoned his theory only between 1906 and 1908, when he was already recognized as the most important French researcher of "cathode rays".²⁸⁸⁴

The Galway native Irishman **John Sealey Edward Townsend** graduated from the University of Dublin in 1890. Between 1896 and 1900, he and Rutherford were the first intern researchers at J. Thomson's labs in Cavendish, when they officially introduced that status there. Townsend was a better mathematician than Rutherford and was chosen for a Wykeham professor of physics at Oxford and the head of the Electric Laboratory in 1900. In 1941, just few months after he was knighted, he lost his job because he refused to cooperate with the army by teaching the serviceman in Oxford in the wrong time of Anti-Nazi euphoria.

Townsend was the first to describe the ionization of gas in collisions. In 1897 and 1898, together with graduate student Harold Albert Wilson in Cavendish, he measured the total charge of "cathode rays" by weighing drops of water along their track in C. T. Wilson's cloud chamber (foggy cell). He estimated $1 \cdot 10^{-19}$ As and $0.9 \cdot 10^{-19}$ As for positive ions. At the same time, J. J. Thomson determined the charge of the ions obtained after the radiation of the X-rays. In 1898 he gained slightly higher values, $2.2 \cdot 10^{-19}$ As, and later $1.1 \cdot 10^{-19}$ As in 1901.

²⁸⁸⁴ Lelong, Villard, 1997, 94, 96, 102, 115, 116, 119, 121–122, 129.

Robert Andrews Millikan was born in Illinois in a Protestant priest's family. In the college of his small town, physics was taught primarily during the teaching of the ancient Greek language. He enrolled at Columbia University as the sole listener oriented towards physics. In the meantime, he studied for a year at Michelson's class in Chicago. After his PhD at Columbia University, he traveled to Europe to listen to the lectures of Planck, Nernst and Poincaré with the help of the Serb Pupin of Columbia University. A year later Pupin invited Millikan to become his assistant with a telegram. In 1910, Millikan became a professor in Chicago and held the position for eleven years. After two decades of lecturing and writing of textbooks he began with experimenting. In 1915, he was elected as new fellow of NAS and then became a scientific adviser to Western Electric (WE). During the war he led the National Research Council. From 1921 to 1945, he headed the new Caltech with his extraordinary talents for the organization. Between the two wars he studied cosmic rays amidst of a sharp exchange of views with American A. H. Compton. In 1923 and 1927 they received the Nobel Prize in Physics one after another anyway.

In 1900 Townsend²⁸⁸⁵ proved that the ionization of gas separates elementary charges of the same size as the ions proved to have in electrolysis.²⁸⁸⁶ It was only around 1910 that he discovered that he measured the electrons. In his experiments, he used much higher pressures compared to the experiments of James Franck and Gustav L. Hertz in Berlin in 1914, who were measured according to the advice of the director Warburg at the Physical-Technical Institute. Townsend thus missed an important discovery. On the other hand, both Franck and Hertz were on the wrong track, as they accepted Lenard's incorrect explanation of the photoelectricity from 1902. As late as in 1916, Franck and Hertz refused to confirm Bohr's theory even if Bohr supported their measurements with his calculations. The mistakes were caused by their lack of time due to their additional military responsibilities in WW1. Townsend never recognized the accuracy of the measurements of

²⁸⁸⁵ Thomson, 1970, 69.

²⁸⁸⁶ Perrin, 1927, 136–141; Vjalcev, 1981, 27–28; Weinberg, 1986, 131, 133–134.

Franc and Hertz, although they received the Nobel Prize for Physics in 1925.

The research centers gradually but slowly moved to the United States while the study of electrons was no exception. Edison's friend Rowland proved that the free charge in the moving conductor produces the same effects as the motion of the charges in a stationary conductor. Maxwell was especially impressed with their measurements as they turned their experimental problem upside down like Copernicans, Torricelli's pressure of air, radiometer researchers or Salcher in his collaborations with Mach.

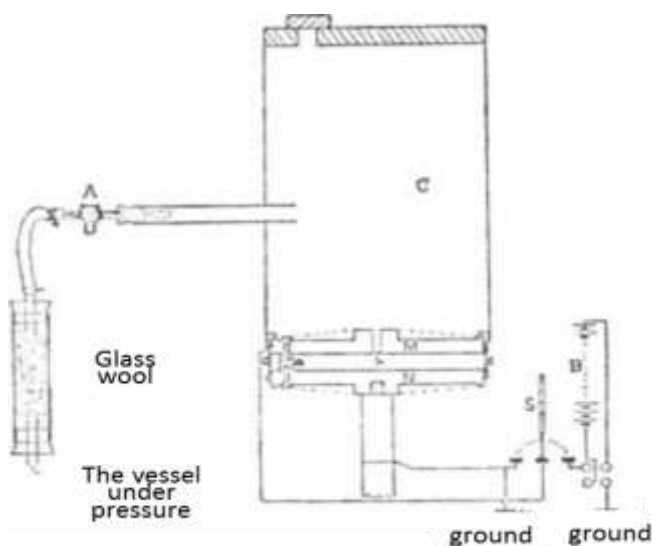

Figure 24-3: Millikan's measuring device²⁸⁸⁷

In 1906 in Chicago Millikan repeated Erich Regener's (1881 Wilczak in Poland-1955 Stuttgart) Berliner visual counting of scintillations as well as Wilson and Thomson experiments carried out in Cavendish to determine the magnitude of the charge in 1902. Millikan made up a stronger source to provide up to 10 kV needed for his "dropping process". Millikan placed his copper plate of radius 22 cm at the distance of 15 mm into a vessel whose variable pressure he measured with a manometer. Between his 10 kV voltage panels, Millikan ionized the air with X-rays. He was blowing a drop of oil that evaporated slower than water and watched through the telescope. The mass of droplets was determined by the rate of drop (Figure 24-3). Dr. Fletcher accidentally noticed that he could keep on floating individual droplets for a very long time with the electric force of the condenser. Thus, he was able to accurately

²⁸⁸⁷ Fletcher, 1982, 44.

measure their charge, which was always a multiple of the basic charge of $1.55 \cdot 10^{-19}$ As. He quickly dialed Millikan and then they measured for six weeks. Originally, they copied the experiments from Cavendish by counting and weighing condensed droplets, but the Americans soon turned into balancing them. They began to measure the rate of deflection only after it became constant. After passing the droplet over a certain point, they turned the direction of the electric field and found the speed of the ascending of the drop. They measured and determined the charge and mass of droplets.

In Edison's style, they published their data even in daily press and received a lot of attention. The famous little clever guy Steinmetz visited Millikan's laboratory and only then began to believe in the existence of electrons.

The Mormon **Harvey Fletcher** studied at the University of Chicago. After a brief collaboration, Millikan proposed the measuring of the electron charge for Fletcher's doctoral dissertation. His share of Millikan's measurements was published only after his death.²⁸⁸⁸ Fletcher received his doctorate in 1911. He researched at Bell Labs between 1925 and 1952 and then taught at the Columbia and Brigham Young universities.

In August 1909, Rutherford at the BAAS meeting in Winnipeg, Canada, argued that "it has not yet been possible to detect an individual electron according to its electrical or optical effects, thus directly counting them, as they did with α -particles." On August 31, 1909, Millikan reported on successful measurements at the same meeting. On September 30, 1909, Millikan's paper was published, but only with the signing of Millikan, who won his Nobel Prize in Physics in 1923. In 1913, Millikan and Fletcher measured the basic charge of $1.591 \cdot 10^{-19}$ As.²⁸⁸⁹ Fletcher was obviously somewhat neglected in Millikan's race to become the father of electron instead of J.J. Thomson, and Millikan might also perform some cooking of his data to make them more convicting also against the Jew Felix Ehrenhaft's supposed smaller units of electrical charges.

²⁸⁸⁸ Weinberg, 1986, 136.

²⁸⁸⁹ Filonovič, 1990, 158–166; Weinberg, 1986, 140.

Table 24-1: "Discoverers" of Electron. Explanation of abbreviations used for methods: B - Measurement of electron deflection in a magnetic field; E - Measurement of deflection of electrons in the electric field; H - Measurement of energy needed for the acceleration of cathode rays (electron heating); I - Measurement of wide-beam deflection in a variable electric and magnetic field and measuring of the duration of the current; L - Measurement of velocities of electrons; R - Measurement of breaking of electrons in the electric field; V - Measurement of the voltage difference used for electron acceleration.

Year	Researcher	Place	Source	Method	e/m (10^{11} As/kg)	V (10^7 m/s)
1890	Schuster	Manchester	“Cathode rays«	B	0.00005–0.1	/
31. 10. 1896	Zeeman, Lorentz	Leyden	Spectral lines	B	over 1	/
March 1897	Wiechert	Königsberg	“Cathode rays«	B	approximately 1	/
21. 5. 1897–1898	Kaufmann	Berlin	“Cathode rays«	B	1	/
30. 4. 1897	Thomson	Cambridge	“Cathode rays«	B, E	0,77	2.2-3.6
30. 4. 1897	Thomson	Cambridge	“Cathode rays«	B, H	1.0–1.4	2.4-3.2
1898	Lenard	Heidelberg	»Lenard’s rays«	B, E	0.639	/
1898	Lenard	Heidelberg	»Lenard’s rays«	B, R	0.68	/
1899	A. W. Simon		“Cathode rays«	B, V	1.865	/
1899	Wiechert	Königsberg	“Cathode rays«	B, L	1.26	/
1899	Thomson	Cambridge	Photoelectrons	I	0.76	/
1899	Thomson	Cambridge	Glowing metals	I	0.87	/
1900	Lenard	Kiev	Photoelectrons	B, V	1.15	/
Early in 1900	Becquerel	Paris	X-rays of radium	B, E	1.0	20
1901–1902	Kaufmann	Berlin	X-rays of radium	B, E	1.77	/
1901	Seitz		“Cathode rays«	B, E	0.645	7.03
1902	Seitz		“Cathode rays«	B, H, V	1.87	5.7-8.5
1903	Stark	Göttingen	“Cathode rays«	B, E	1.84	3.2-12
1904	Owen	England	Glowing oxides	I	0.56	/
1904	Wehnelt	Erlangen	Glowing oxides	B, V	1.4	/
1905	Reiger		“Cathode rays«	B, R	1.8	10
1905	Reiger		Photoelectrons	B, V	0.96–1.2	/
1906	Evers		X-rays of polonium	B, E	1.7	/
31. 8. 1909	Millikan	Chicago	Electrified drops	E	1.70	/
1916	Richard C. Tolman, T. Dale Stewart	USA	electromotive force produced by accelerated metals		1.6	/
1909–1913	Millikan, Fletcher	Chicago	Electrified drops	E	1.73	/
1923–1929	H. D. Baock, W.V. Houston	USA	Zeeman’s effect	B	1.761	/
Today					1.7588048	/

Table 24-2: The discoverers of "Electrons" in the eyes of contemporaries

Author of note	Announcement time	"The discoverer of electrons"
Kaufmann	at the end of 1899	Zeeman
Bohr	Nobel laureate's lecture in 1922	Lenard and Thomson
Rutherford and his collaborators	1930	Thomson, Wiechert and Kaufmann

Table 24-3: Nobel Prizes in Thomson and Rutherford's labs

	Field	Researcher	Nationality	Laboratory (director)	Time of cooperation
1906	Physics	Thomson	Englishman		
1908	Chemistry	Rutherford	New Zealand	Cavendish (Thomson)	1895–1898
1915	Physics	W. L. Bragg	Australian	Cavendish	1908–1919, with Wilson
1917	Physics	Barkla	Englishman	Cavendish (T)	1895–1902
1921	Chemistry	Soddy	Englishman	Montreal (Rutherford)	1900–1902
1922	Physics	Bohr	Dane	Manchester (R)	1912–1916, also Cavendish 1911
1922	Chemistry	Aston	Englishman	Cavendish (T)	1910–1913, later independent
1927	Physics	Wilson	Scotsman	Cavendish (T)	1900–1934, professor after 1925
1928	Physics	Richardson	Englishman	Cavendish (T)	1901–1906
1935	Physics	Chadwick	Englishman	Cavendish (R)	1919–1935, director's deputy after 1923
1937	Physics	G. P. Thomson	Englishman	Cavendish (T, R)	1919–1922
1943	Chemistry	Hevesy	Hungarian	Manchester (R)	1902–1914
1944	Chemistry	Hahn	German	Cavendish (R)	
1947	Physics	Appleton	Englishman	Cavendish (T)	1920–1924, assistant of demonstrator
1948	Physics	Blackett	Englishman	Cavendish (R)	1923–1933
1950	Physics	Paul	Englishman	Cambridge	Only studied until 1925
1951	Physics	Cockroft	Englishman	Cavendish (R)	1925–1939
1951	Physics	Walton	Irishman	Cavendish (R)	1930–1934
1967	Physics	Bethe	German	Cavendish (R)	occasional visits
1978	Physics	Kapica	Russian	Cavendish (R)	1921–1935

Most of the differences in terms of modern value of the unit of elementary electrical charge are caused by the inaccurate measurement of air viscosity in Millikan's times. However, Millikan measured 175 drops, including 107 after 13 February 1912, when he made the first published measurements. Nevertheless, he published only 58 measurements, since others did not fit well enough with theory while Millikan criticized Viennese Ehrenhaft, who had a much better measuring device available as a professor of the University of Vienna since 1912. Ehrenhaft received his doctorate at F. S. Exner's class. In 1901, as an assistant to Viktor Edler von Lange in Vienna, he

measured the charge of metal particles estimated as $1.53 \cdot 10^{-19}$ As. Independently of Millikan, he developed a process for measuring the basic charge of his drops. However, he claimed to also measure sub-electronic charges smaller than the electronic one. While Millikan was a convinced atomist, Ehrenhaft defended the continuity of matter and never accepted Millikan's measurements of the falling droplets. However, at the Solvay Congress in 1911 Friderich Hasenöhrl reported that Ehrenhaft's assistant the Jew Karl Przibram also accepted Millikan's results. At the same congress, Einstein reported on the measurements of his assistant at the German University of Prague,

Edmund Weiss, who gave new evidence against Ehrenhaft's theory. Thus, Ehrenhaft retained only the support of some of his pupils, such as Lecher, F. Zerher, and the Protestant of Jewish origin David Kurt Konstantinowsky (* 1892 Vienna). After relocating to the United States, he had major problems in physical circles.²⁸⁹⁰

Later, it turned out that Millikan's device was not useful for drops with a charge of more than 30 base charges. Nevertheless, Millikan's measurement was at least 16 times more accurate than the previous ones. He only committed a mistake of about 0.5%, which he even did not publish as he wasn't obliged to do so in his times. His measurements were quickly repeated in other laboratories.

24.1.1.6 Significant Contributions to the »Discovery« of Electrons

In the last decade of the 19th century, over seventy discussions, directly related to the discovery of "electron", were published mostly in 1894 and even more in 1897 (Table 24-1). The contemporaries attributed the discovery to various persons (Table 24-2).²⁸⁹¹

The discovery of the electron was a long-standing process, which, due to simplicity, is mostly attributed to Thomson. Thomson did not publish the most accurate experiments, but he unambiguously explained the results full of Victorian English pride as his own discovery of a new particle. Millikan added his own Yankee style to become a beloved father of MIT.

24.1.2 Thomson's Study of "Positive" Rays (1906-1914)

After the discovery of a "corpuscle" with a negative charge, Thomson wanted to detect a "positive" electricity. Therefore, at the beginning of the 20th century, he began to explore "positive"

rays. Despite some successes, the project did not bring such high-profile results as the older cathode ray research.

In 1886, Goldstein discovered "canal rays," which later proved to be a stream of positive ions. In the early years of the 20th century, the initiative was taken over by the French in the search for rays, but their contribution was very infamous. At first, they strongly supported the N-rays, which were "discovered" by Blondlot at the University of Nancy in 1903. However, by 1906, it turned out to be a mistake. In March 1906, J. Becquerel, son of Nobel Laureus Henri, published a surprising discovery of positive electrons, which in the following years also proved to be an experimental error.²⁸⁹²

In the years before the First World War, Thomson explored "canal rays". More than two decades after Goldstein's discovery, they were still a kind of enigma. It was not known much about them besides that they were positively charged and that their e/m ratio was comparable to that of hydrogen. Only in 1928 the student of Thomson's Cambridge Paul Dirac published a valuable theory of positive electron later named positron.

24.1.3 Search for the Atomic Composition

In his first research of discharges, JJ Thomson supported W. Thomson's vortex model of atom in 1882 and in 1884. A few months before H. Nagaoka, J.J. Thomson published a model of atom with an evenly distributed charge of both types in his Silliman lectures at the University of Yale, USA.²⁸⁹³ The following year he described groups of electrons in the atom, which induce the periodicity of chemical elements. His atom consisted of thousands of rotating particles that radiate and destabilize the atom. The idea was explained only by the connections between the ionized molecules.

Thomson did not declare a mass of his carriers of positive electricity in 1905. The holders are supposed to bind together particles in the atom by analogy with the hydrodynamics of the fluid ether in the "Faraday tubes". He thus composed a model of a ball of uniform positive energy, with small separate particles moving inside. Although he had to abandon such a model in 1906, he still thought of Faraday's forces. His models of atoms were

²⁸⁹⁰ Nye, 1983, 32; Millikan, 1963, 163.

²⁸⁹¹ Anderson, 1968, 41, 53, 60, 62, 64; Vjalcev, 1981, 74, 77, 79–81.

²⁸⁹² Dahl, 1997, 242–251, 257–264.

²⁸⁹³ Vjalcev, 1981, 84; Feffer, 1989, 38–39; Weinberg, 1986, 141.

most likely designed by the concepts of "corpuscles" he himself discovered.

In 1906, measurements of the scattering of light and X-rays and the absorption of β -rays in gases showed that the number of "corpuscles" in the atom is of order of magnitude of its mass number. The positive electric could no longer be described without mass of its carriers, which should have even been much larger than the mass of electrons. That is why Thomson abandoned the use of Faraday's forces and the assumption of a completely electromagnetic mass of positive rays which he adopted at the beginning of the century.²⁸⁹⁴

24.1.4 Measurement of e/m Ratios of "Positive Rays"

In 1904, Fitzpatrick, a former demonstrator in Cavendish, and then president of the Queen's College, donated to the Cavendish Laboratory a device for liquefying of air. In that time, they used Sprengel's or Töpler's pump. In 1905, the inventive Gaede pump was very expensive, so there were only three or four of them in Cavendish in 1913.²⁸⁹⁵ The vacuum was improved with charcoal cooled in the liquid air, which was added to the cathode-ray tube. The process was first introduced by Dewar and was even better than Gaede's rotary pump for a short while after pumping. Later, when charcoal absorbed all the gas it could, it no longer helped to maintain the vacuum. J. J. Thomson and Aston had only a very small hole in their vacuum flask connected to the discharge vessel by narrow capillary. Therefore, they were able to use the absorbing abilities of charcoal even for an hour and more.

Considering the success in measuring the e/m ratio of his corpuscle, Thomson decided for similar measurements of positive "canal" rays in 1905. He deflected them into a parabolic orbit by the electric and magnetic fields. The results were heavily dependent on the pressure. At a pressure of 0.026 mbar, he observed almost flat luminous lines on the screen made of willemite.²⁸⁹⁶ The lines of negative particles were symmetrical but pale. Due to straight lines, Thomson assumed that the "canal" rays had a constant velocity, but the variable e/m

ratio with a maximum value which was the same as that of a hydrogen ion. Just as a decade earlier he assumed that atoms consist of "corpuscles", this time Thomson claimed that hydrogen ions are the basic building blocks of all atoms, following the famous Prout's ideas. At lower pressures down to 0.0039 mbar, the negative lines disappeared, and the positive lines were split into the curves. Because of the different e/m ratios, Thomson felt that the charge of the particles was changing, rather than their mass. A similar assumption was published by Helmholtz's student, an alleged East Prussian farmer W. Wien in 1898 and 1902. Thomson changed the pressure and type of gas in the measurements, but he always got the same line with the e/m ratio of 10,000 and 5000 (Figure 24-4).

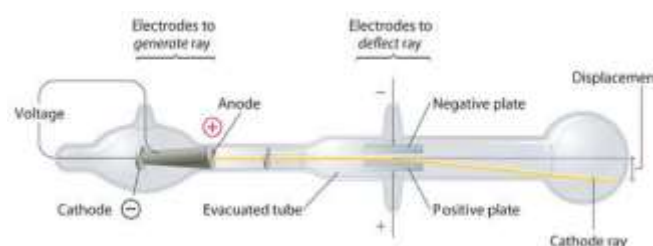

Figure 24-4: Thomson's cathode ray tube from 1907 used for his observation of positive rays on the luminescence screen from willemite. The vacuum was improved with an out growth full of charcoal cooled in liquified air

In 1908, Thomson announced that positive rays were neutralized at least during a fraction of the time measured, which he tried to explain with a pair of heterogeneous charges. In March 1909, Thomson bought for his lab Wehrstern's inductor "Mercedes", which supplied up to 20 kV of accelerating voltage, much more than Wimshurst's inductor, which was predominantly used as a supply of the multi-colored Geissler tubes in the late Victorian era.²⁸⁹⁷ Unfortunately, the results did not change, as the speed of positive rays was the

²⁸⁹⁴ Falconer, 1988, 271.

²⁸⁹⁵ Thomson, 1967, 175, 181; Dahl, 1997, 284.

²⁸⁹⁶ Zn_2SiO_4

²⁸⁹⁷ Bowers, 1998, 115.

same in all gases, regardless of the acceleration voltage.

Francis William Aston was the son of a wealthy metal dealer in Birmingham. He studied chemistry at the University of Birmingham and worked there between 1903 and 1908. He laboured for three years in a brewery, where he became interested in discharges.²⁸⁹⁸ Like in Joule's case, beer again proved its beneficial influences on English physics. At the beginning of 1910 Aston became Thomson's research assistant. In 1913 he was selected for Maxwell's scholarship in Cavendish to develop his own research direction. In 1907, Thomson described the action of the mass spectrograph for the separation of the ions of various isotopes, already announced by Crookes in 1886. In 1912, the experiment first demonstrated the existence of isotopes of neon. The first mass spectrograph was compiled by Aston in 1919, and in the same year he proved the existence of chlorine and mercury isotopes.²⁸⁹⁹ In 1922 he received the Nobel Prize in chemistry for his invention of spectrograph and research of isotopes. In 1925 and 1937 he improved the performance of the spectrograph. He discovered a mass defect, and he measured numerous isotopes in 1927. In 1931 he discovered the isotope ²³⁸U.

After Aston's arrival, they began to measure more precisely in Cavendish labs. In September 1910, they increased the volume of the central part of the cathode ray tube to 2 l and cooled the charcoal in the liquid air to enable the measurements at lower pressures. In 1910, the basic experimental problem was a sufficiently high pressure needed for the discharge, and at the same time a sufficiently high vacuum in the vessel for deflection of charged particles. Therefore, they separated the discharge space from the electromagnetic deflection vessel by Lenard's method designed in 1895, which was already used for X-ray detection. Lenard's "window" began to be used in England in 1897, and only a year later in Germany, since Lenard interrupted experiments between 1896 and 1897 during his editing of the works of the deceased Lenard's boss, the Jew Hertz, long before Lenard developed his Anti-Semitic stances. Although Lenard's experiments were highly valued in England, the Brits immediately rejected his model

of transmitting mechanical impulses in the ether and his assumption of the substance "Urstoff", the same for all atoms.²⁹⁰⁰ The British physicists clearly disliked the German philosophical impacts even if they praised their accurate measurements.

In the beginning of 1910, Thomson used his old model of atom to treat the scattering of β -rays in matter, and two years later he reused it in his description of ionization. In the autumn of 1910, instead of the luminescent screen, he began to photograph "positive rays". Initially, the show lasted a few hours, then 3 minutes or less. With a tough heart he had to admit that in the older measurements he did not detect heavier ions because of the insensitivity of his luminescence screen from the willemite (Fig. 24-5).

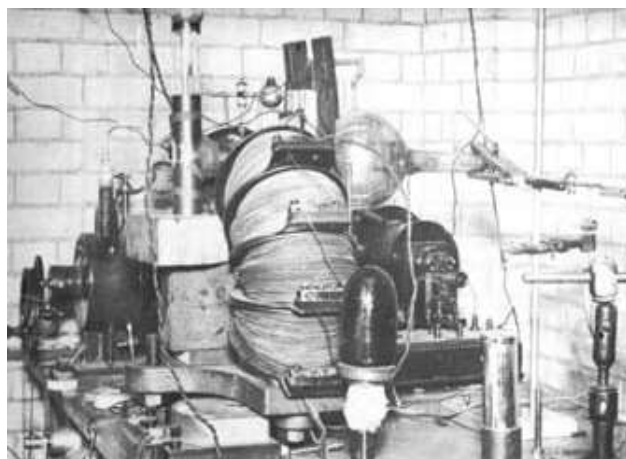

Figure 24-5: Thomson's measuring device from the period after 1910 which he used to photograph "positive rays". It included a large discharge vessel, a charcoal container cooled in the liquified air, and a large electromagnet.²⁹⁰¹

After 1898, Thomson imagined ionization as result of a collision of the rapid cathode ray with the molecule from which it breaks out a new cathode ray. However, he did not know for sure whether the whole ion was splitting off from the molecule, as he believed in 1907 and he presumably confirmed with his measurements in 1910. Perhaps only the emission of the electrons and the ionization occurred?

In 1911 observations in the improved Wilson's cloud chamber (foggy cell) convinced Thomson that most ions in the gas formed after a collision

²⁸⁹⁸ Thomson, 1970, 51.

²⁸⁹⁹ Robinson, 1963, 97.

²⁹⁰⁰ Lenard, 1905, 369, 378, 391, 558–559; Darrigol, 1998, 22–23; Vjalcev, 1981, 66.

²⁹⁰¹ Falconer, 1988, 297.

between ions and molecules. In 1912, he used Faraday's cylinder designed in 1843 for one of Thomson's few quantitative measurements, but soon he returned to qualitative measurements with photographic plates.

By 1910, Thomson still thought that the unit of positive electricity was a hydrogen ion. In 1912, this idea was finally abandoned, as the precise Aston proved that his early results were the result of the pollution of the measuring apparatus with hydrogen, although the gas could not be detected spectroscopically. Research on "positive rays" was no longer an answer to the question of the nature of electricity. Therefore, Thomson abandoned it and returned to study the composition of atoms and light.²⁹⁰² Already at the 2nd Solvay Conference in the summer of 1913, he described the quantum emission and absorption of radiation with his new atomic model. At the center of the atom, he imagined positive charges with most of the electrons, surrounded by rare weakly bound valence electrons. Until 1921 he probably thought that the mass of the atom consisted of α -particles, while hydrogen atoms were added only to the nucleuses with the odd mass numbers.²⁹⁰³

24.2 Spread of Thomson's Ideas

24.2.1 *Nobel Laureates among Thomson Co-workers and Rutherford*

Soon after the end of the First World War, Thomson left the heading of Cavendish laboratories to his former pupil Rutherford. He retained only a modest laboratory for exploring the positive rays in Cavendish and the honorable position as the head of the College of St. Trinity. He left a magnificent job behind him. Seven of his assistants received the Nobel Prizes, and twenty-seven of them were elected FRS. For some time, Thomson's students taught at most physics departments in Britain and in many other English-Speaking countries (Table 24-3).²⁹⁰⁴ The success of Thomson's followers could be compared only with similar gains of Bošković's and Stefan-Boltzmann's fans in Habsburg monarchy or with the fame of later Bohr's Copenhagen interpreters of quantum mechanics. Among all those heroes,

J.J. Thomson might be the best example of the able ambitious theorist who headed the prosperous experimental lab.

Even a "sun has its spots" and even JJ Thomson did not correctly evaluate the talent of Niels Bohr when he was a young postdoc doctor in Cavendish. In autumn of 1911 he proposed to Bohr an experiment with "canal" rays, but Bohr did not overjoy, because he would prefer some calculations. During this time, most experimental devices in Cavendish had to be made by themselves, including blowing glass, which was not Bohr's favorite. Later, Rutherford befriended Bohr much more because of Bohr's soccer performances.

Nonetheless, Thomson's theory of atom had a major impact on Rutherford's nuclear model in the winter of 1910/11.²⁹⁰⁵ After the First World War, Thomson slowly began to lose contact with new discoveries. During the war, the flow of German and French newspapers in Cambridge was interrupted, and after the war, Thomson did not renew their subscriptions for one or another reason. Since German physicists at that time were as important as the later American ones, Thomson remained outside of the ideas of new generations of physicists.²⁹⁰⁶

Basically, Thomson accepted criticisms of his colleagues during interviews in the laboratory. His opinion was always ready to change under the pressure of arguments. Thus, on August 7, 1887, he was horrified to report to his friend and colleague Threlfall about suggestions that the girls should attend university lectures. Less than half a year later, on January 2, 1890, he married his student Rose Elisabeth Paget. Similarly, Boltzmann was also affected a decade earlier with his Jetty. Never say never! Millikan did not support feminization of USA science later in 1936, but he was already married by then.

24.2.2 *Echoes of Thomson's Research in Slovenia*

Before the end of the 19th century it was not possible to obtain a valid answer on the nature of electricity in the Slovenian language: "What is

²⁹⁰² Falconer, 1988, 265–267.

²⁹⁰³ Falconer, 1988, 271–308.

²⁹⁰⁴ Filonovič, 1990, 152–153; Thomson, 1967, 172 .

²⁹⁰⁵ Dahl, 1997, 338.

²⁹⁰⁶ Thomson, 1967, 155.

electricity? ... We must acknowledge that we do not know the answer to the question we put at the beginning of this paragraph. We have come to one of those limits, which we cannot exceed. I will not say that the scholars do not know incredibly cleverly to clarify the different electrical displays. But on the last cause of these depicting effects, we cannot say anything final with all the erudition of the world..."²⁹⁰⁷

JJ Thomson's model of an atom full of electrons had advocates in Slovenian lands just before World War I: "Recent research has brought many almost unexpected novelties about the composition of the atomic substance. Above all, it turned out that matter does not fill the entire atomic space, and that we must think of an atom composed of a large set of very fine body particles. These many thousand times smaller and lighter particles than atoms are called electrons. The lightest hydrogen atom has over 2000 electrons inside it; the other atoms certainly have even more of those. As the atoms in the body are constantly moving and shaking, electrons similarly circulate in a small space of atoms with a high velocity..."²⁹⁰⁸ Certainly, Thomson's own ideas which later did not prove to be totally accurate.

Before the First World War, secondary school students in Slovenia were taught about electrons and positive rays:²⁹⁰⁹

"The electron is the smallest electrified material particle that is significantly different from the material atom ... There are also rays that fall on the cathode in the cathode ray tube space; if the cathode is porous, the rays run through it and they form on the other side the so-called canal rays. The magnet deflects them in the opposite sense as the cathode rays, but not with the same strength. Therefore, they are also positive electrons; their speed is smaller, their mass is larger than the mass of negative electrons."

A decade later, Slovenian ancestors read: "... the atoms of electricity which are separated from the ordinary matter. Thomson has named them corpuscles, and today we widely use the name 'electron' given to them by Stoney. Crookes' theory

became the beginning of a very fruitful electronic theory."²⁹¹⁰

Jožef Reisner, a graduate student at the Faculty of Arts in Vienna, served his one-year military term. From 1895/96 he received Knafelj's scholarship. Between 1899 and 1900 he was substitute (suplent) teacher in Celje and then until 1904 in the 8th district of Vienna, where he published the discussion "Determination of some definite integrals from definite equations" in German language in the school reports in 1904. Until 1905, he taught at Real school in Idrija and then at the Grammar School in Novo Mesto. In 1908/1909 he took one-year leave to write a textbook. By the orders of the Ministry in June and July 1910, he moved from Novo mesto to the 1st classical gymnasium in Ljubljana. He retired in Ljubljana in 1921, after lecturing on physics at the Faculty of Medicine during his final year. During the First World War, he was mobilized. Between 1921 and 1923 he was a Member of Parliament. Despite his retirement, he was director of the Technical High School in Ljubljana between 1923 and 1938.

²⁹⁰⁷ Schreiner, 1889, 124–125.

²⁹⁰⁸ Čadež, 1908, 25–26.

²⁹⁰⁹ Reisner, 1913, 312–313.

²⁹¹⁰ Čermelj, 1980, 65.

25 Major Industrial Uses of Vacuum Technologies - Electron Microscope

25.1 Electron Microscopy

The English linguistic favouring light particles enabled J.J. Thomson's successes. The continental Europeans far enough from the waves of seas loved waves in their theories much more than islandic Brits, while *qi*-mediated interplay of yin and yang and Vedanta's interconnecting subject and object provided the basis for quantum synthesis of particles and waves. The continental European wave analogy between electron beam and light simultaneously led to important discoveries in physics and electrical engineering. An electron microscope uses a magnetic field instead of lenses and a jet of electrons instead of visible light. Let's look at the development of experimental electron beam focusing technique.

25.2 Optical Microscope

25.2.1 Early Users

The microscope for light was first used a few years after a telescope at the beginning of the 17th century in the Netherlands or at Galileo's networks in Padua.²⁹¹¹ The people first wished to observe the seemingly invisibly small object far away, but soon also turned their attention to the invisibly small object nearby.

The microscopes were used early in Slovenia areas. On November 1, 1705, the Carniolan Provincial Assembly appointed 200 gold-denarius of the annual salary for a professor of mathematics and bought the necessary "mathematical instruments", including the optical devices. On 17 September 1755, a solar microscope and a smaller and larger hand microscope with a sphere were purchased for new Higher studies lab in Ljubljana. The solar microscope with natural light appeared in the 1730s as a tube with a condenser on one side and a simple screw-barrel microscope of James Wilson (c.1665–1730 London) designed in 1702 by Dutchman Nicolas Hartsoeker's ideas as a

²⁹¹¹ Gloede, 1986, 22–28.

projection lens on the other side. Before 1811, in Ljubljana, they acquired a composite microscope and *laterna magica*, as they then called a microscope-projector with a concave mirror and two large lenses.²⁹¹²

25.2.2 Jena: Optical Microscope Capability

In 1873, Abbe published the theory of the microscope as a professor at Jena University and a collaborator of Zeiss Optical Company.²⁹¹³ He showed that we cannot observe distances smaller than half of the wavelength of the light used. With visible light, the limit of resolution is 1/4 micrometres designed in the era of European limits of Carnot's efficiency, absolute zero temperature, relativistic maximum velocity and uncertainty principle mirroring Daoist limits of language and thought. Abbe's ideas about improving the resolution of the microscope by reducing the wavelength of the light used are particularly interesting today: "... There is nothing stopping us from going even further in this direction and imagining microscopic observation with the help of rays lying as far as the boundary of the visible spectrum in the UV region. Although this obtained image is not directly observable, it can be made visible through fluorescent materials..."²⁹¹⁴

Abbe was thinking about UV light because X-rays and the electrons have not yet been detected. Nevertheless, it seems as if Abbe had predicted an electron microscope half a century in advance. The limit of resolution of microscope, however, became distracting when, at the turn of the century, the focus of physical exploration was shifted to the atoms and its particles. Even today, the frequently used term "submicroscopic" illustrates the problems of the atomists at that time.

25.3 Experiments with the Emission of Electrons in the Electromagnetic Field

Abbe's times witnessed decades of researched "cathode rays". Most scientists did not question that they can be curved by an electric field. On 9

²⁹¹² Gurikov, 1983, 163–164; Kircher, 1664, book no. X.

²⁹¹³ Gurikov, 1983, 122, Gurikov, 1985, 39–42.

²⁹¹⁴ Gurikov, 1985, 51; Gloede, 1986, 166.

October 1868 in Münster, Hittorf focused his "cathode rays" with a rotationally symmetric field of a cylindrical magnet. A similar experiment was made by Hittorf's former professor Plücker shortly before his death in Bonn, but Plücker did not publish it anymore.²⁹¹⁵

Hittorf was experimenting at pressures of 0.25 to 0.125 mm Hg. He used an electro-magnetised iron cylinder with a diameter of 10 cm and a height of 50 cm attached to the 10 cm long iron join. At the ends of the cylinder he put amalgamated zinc plates with a diameter of 9 cm.²⁹¹⁶

According to Hittorf, electricity in gases is translated in two ways: from a positive electrode resembling metals and electrolytes, and by discharge from the negative electrode. Under different conditions, the ratio was measured between those two modes of translation. He described the "cathode ray" as a very light "conductor" of the electrical current. The ends of "conductor" are attached to the electrodes while between the electrodes we can bend the rays with magnetic forces. Under the influence of a strong magnet, "rays" move along a curve with two to three full turns along the length of two feet. The divergent rays move after spiraling. The direction of the motion of the "cathode rays" is followed by observing the fluorescence that occurs when the rays sufficiently approach the glass wall of the vacuum tube. The best picture is seen when the cylinder of the vacuum tube is in the axis of armature of magnet.²⁹¹⁷

Hittorf believed in the wave nature of "cathode rays". Therefore, he described their deflection in the magnetic field in analogy with the rotating of polarization plane of light in a magnetic field. Half a century before de Broglie he used an analogy between cathode ray and light.²⁹¹⁸

Hittorf correctly predicted that experiments with the magnetic deflection of "cathode rays" in diluted gases eliminate from physics the very last electrical energy-related imponderable non-weighting substance. His work was supplemented in 1896 by Poincaré's pupil, the Norwegian Birkeland. Thus, the necessary knowledge for the

development of electronics was prepared after the First World War.

25.4 The Beginnings of an Electron Microscope

The uses of established branch of physics in another developing branch helped J. Stefan's description of the diffusion process in terms of hydrodynamic laws applied in physiology. Hydrodynamics of blood became a model for heat transfer. The similar analogy between geometrical optics and other branches of physics has been repeatedly used in the century between the researches of Hamilton and Ruska. In 1826 and 1832, the geometrical optics became part of Irishman Hamilton's science. In 1834 and 1835 Hamilton expanded his idea of the characteristic function of the state from optics to mechanics. His achievements were only used in quantum mechanics.

The Frenchman de Broglie attributed wavelength to material particles in 1923. In this way he turned upside down Boltzmann's (1872) and Planck's (1900) idea of quantization of electromagnetic wave.

The "material waves" theory independently influenced experimental physics and electrotechnics. In the 1920s, the German physicist Brüche coined the term "electron optics".²⁹¹⁹

25.4.1 Abbe's Successors in Jena Accomplish his Vision

On 18 October 1926 at the Physics Institute in Jena Busch published the equations for the motion of electrons in an axially symmetric magnetic and electric field by analogy with geometrical optics. He found that the focal point is a "cathode ray" current on the axis of symmetry passing through the entry point. He described the method for determining the distance between the electron source and the focal point of their jet with a mass and charge ratio (e/m) to a precision of one thousandth of a percent.²⁹²⁰ On March 29, 1927, his Ph.D. student in University of Jena Fritz Wolf used that method.

²⁹¹⁵ Hittorf, 1869, 220–221; Ruska, 1990, 357.

²⁹¹⁶ Hittorf, 1869, 214.

²⁹¹⁷ Hittorf, 1869, 215–217, 219, 223.

²⁹¹⁸ Hittorf, 1869, 221; Vjalcev, 1981, 41, 47.

²⁹¹⁹ Gurikov, 1985, 54.

²⁹²⁰ Busch, 1926, 993; Gloede, 1986, 170.

At the end of May 1927, Busch modified his idea in Braun's cathode ray tube, where a small deflection coil influenced the electron beam as a convex lens with the same focal length influences light. He described his electric field like the refractive index in optics. The idea was based on Schrödinger's wave-mechanical analogy between the beam of light and the particles with a mass, published in January 1926. To avoid sputtering, a sphere of 13 mm diameter was used for the cathode. Anode was a metal tube with a diameter of 25-30 mm and a length of 20-30 cm with a circular aperture of 8 mm diameter. On the fluorescent screen, more than 10% of his total electron flow drew an image with 0.3 mm diameter.²⁹²¹

In 1927, Busch calculated the electron trajectories in the magnetic field. He found that the magnetic field of a short coil equally affects the electron beam, like a convex lens with a fixed focal length affect the light. The focal length of these "magnetic electronic lenses" can be continuously modified with the electrical current through the coil. Because of his lack of time, Busch did not make new experiments, but used his dozen years-old measurements from Göttingen. These did not fit well with theory, so he did not dare to announce the possibility of using an electron microscope.²⁹²² However, the great idea was there between the lines.

25.4.2 Electron Microscope in Berlin

At that time, a Berliner professor at the Faculty of Electrical Engineering and director of the Electronic Institute of Technical High School in Berlin-Charlottenburg Matthias Knoll founded a research group led by Knoll. Development of an effective electronic oscillograph for the measurement of high-speed electrical processes was their goal. The most important parameters that define the precision of the measurement in such an oscillograph on the "cathode ray" are the diameter and energy density of the electron beam. For a small bright spot, electrons from a divergent cathode ray tube must be focused on the fluorescent display of oscilloscope.

²⁹²¹ Busch, 1926, 993 and 1927, 583, 588, 592, 594.

²⁹²² Ruska, 1986 357.

A student Ruska was included in the research group, as he just came to the University of Berlin after two years of electrical engineering studies in Munich where Sommerfeld also taught. In 1929, Ruska tried to verify Busch's theory of magnetic lenses. He investigated the sharpness and brightness of the freckle in the short-circuit electronic oscillograph. He got better results than Busch. However, he was not entirely pleased, as he, like Busch, used a coil with a very wide distribution of the field along the axis.

Ruska has published the first images of various magnification obtained by electron focusing. In 1930 in his diploma thesis, he focused a jet of electrons with electrostatic lenses. The choice was based on a mistake and turned out to be a disappointment. Therefore, he soon returned to magnetic lenses from his student times. After graduating in 1931, Ruska was considered happy that he could retain an unpaid doctorate post at the Institute for High Voltage in Berlin in the middle of severe economic crisis which brought Nazis to power.

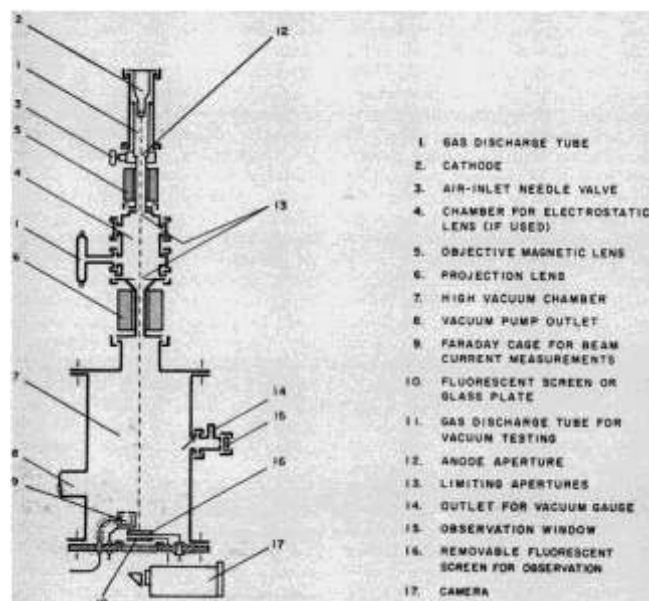

Figure 25-1: Sketches of the first Ruska's Electron a microscope with two magnetic lenses from 1931

Between 9 March and 7 April 1931, Ruska created the first electron microscope with a magnification of 3.6 to 4.8 hundred times (Figure 25-1). However, even the molybdenum or platinum grids quickly burned in the electron beam. Therefore, on 4 June 1931 Knoll avoided the term "electron microscope" in his professional lecture in Berlin.

Many researchers (rightly) did not believe in the future of such a device. The shorter wavelength of the electrons increased the resolution, but at the same time increased the energy of the electrons that destroyed the observed sample.²⁹²³ As usual in many problems of physics, the preferred circumstances tend to obstruct each other.

At the same time, other German physicists studied the electron microscope. E. Brüche and Helmut Johannson († 1982) obtained images with an electron microscope between 1931 and 1932, almost simultaneously with Ruska and Knoll.²⁹²⁴

On 31 May 1931, Wiechert's student Rüdberg patented basically the same Ruska's idea on behalf of Siemens-Schuckert-Werken in Berlin. Rüdberg wished to observe small dangerous viruses which bothered his younger son. Due to the protests of Allgemeine Elektrizitätsgesellschaft, which had been conducting similar research since its founding in 1928, he has only patented his novelties in the US. He escaped to America from Hitler's Germany as one of those great Jews which Nazis lost.²⁹²⁵

Thus, several researchers in Berlin simultaneously approached the "discovery" of an electron microscope. Despite the economic crisis, the German industry has substantially supported basic research. In 1932, Knoll calculated from Abbe's equation that the electron microscope can distinguish the points separated by 0.22 nm, which was indeed only achieved forty years later. In April 1932, Knoll went to Telefunken of Berlin, where he worked on the development of television. At that time, Codelli also designed Telefunken's television technics.

Soon after Nazi's takeover, in November 1933, Ruska assembled an electron microscope with a 12,000-fold magnification. He published the first images with the new device few days after on 1. 12. 1933, when he left the university and got engaged in the industry. Together with his colleagues, he later received a special laboratory at Siemens with a specialized workshop for "serial" production. They also had a propagandist laboratory for guests, especially biologists and doctors, where visitors could observe viruses. During the Second World War from around 1939

to February 1945, they distributed about forty electron microscopes (Figure 25-2).²⁹²⁶

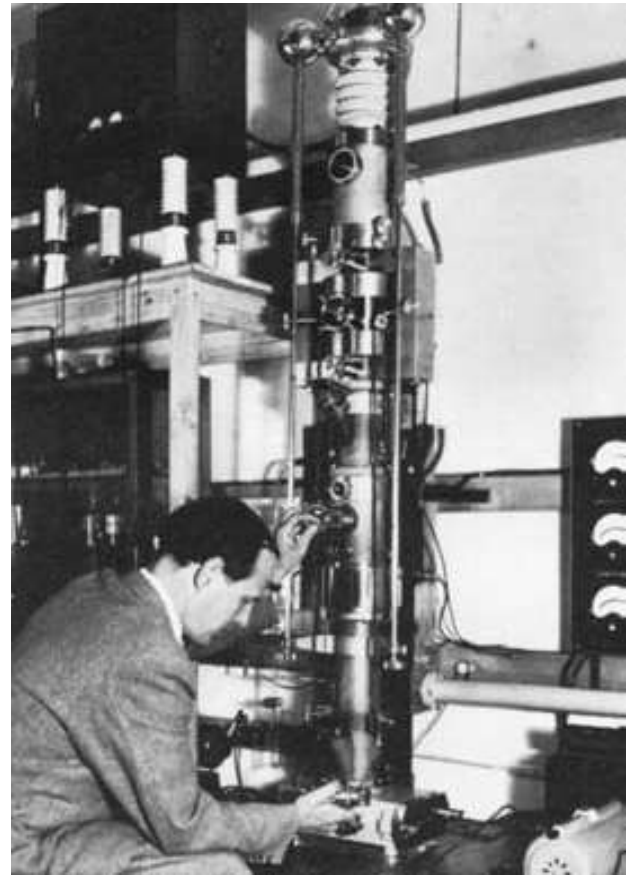

Figure 25-2: Manfred von Ardenne (1907-1997) measures with his universal linear electron microscope, which he first described at the end of 1937

25.5 "Parallel (Independent)" Discoveries in the Development of an Electron Microscope

The promising applicative technologies usually attract a lot of money from expecting businessfolks. In those privileged circumstances unplanned discoveries flourish. That fact is often used as the excuse for disastrous military projects involving unhuman researchers.

In case of electron microscopy, the unexpected inventions were especially numerous because it combined novel electronic technology with the most ancient geometrical optics basically developed already in the old Islamic Middle East.

²⁹²³ Ruska, 1986, 360–361, 377–378.

²⁹²⁴ Gurikov, 1985, 54.

²⁹²⁵ Siemens, 1957, 2: 193; Gloede 1986, 177–178.

²⁹²⁶ Ruska, 1986, 357–362, 369; Siemens, 1957, 2: 194.

25.6 The United States and England: the Refraction and Interference of Electrons

25.6.1 *European Mainland Love Waves Spread Overseas*

Ruska's idea of a wave aspects of "cathode rays" was vivid in Berlin already from the time of Helmholtz and Hertz. In the summer of 1931, the engineer Ruska first heard of de Broglie's "atomes couplés en onde", although the first publication was eight years old and de Broglie had already received the Nobel Prize in physics in 1929. The delay was due to the gap between Broglie's fundamental physics and Ruska's applicative engineering which prevented the guys from both fields to study each others' publications even if approaching combined Daoist dual nature of matter was in the air already during Ruska's studies in Sommerfeld's Munich.

On 10 September 1931 Ruska and Knoll did not mention de Broglie and GP Thomson in their analogy between the rays of light and the path of the massive particles with a mass in electron optics. Knoll only heard about de Broglie's work from Houtermans at the beginning of 1932. Ruska and Knoll quoted Davisson's and Germer's and Rupp's measurements of the diffraction of electrons after their reflection on crystals or on the artificial diffraction gratings, and when passing through a thin metal sheet.²⁹²⁷

Such "lack of information" is not unusual, as it was about research in sufficiently different branches of science: in practical electrical engineering and in theoretical physics. In addition, De Broglie's ideas were not easily endorsed even among theoretical physicists.

In July 1923, a professor of physics at Göttingen Franck encouraged his Jewish assistant later expert in theoretical biology Elsasser to analyze two types of experiments that could confirm de Broglie's equation. However, convincing experiments only succeeded in the USA later. As early as in 1921, Davisson in Western Electronics, the later Bell Telephone Laboratories, investigated the electron

beam's reflection on a plate made from nickel in a vacuum. Together with Germer, he noticed by chance more pronounced amplifying after a reflection on a mono-crystal at the end of 1925.

In the summer of 1926, Davisson and Aberdeen professor G.P. Thomson attended a scientific meeting of the British Association in Oxford. There they got inspiration for new experiments. On 6 January 1927 in Western Electric of Manhattan in New York, Davisson and Germer observed an interference image of the scattering of slow electrons that fitted well with De Broglie's theory. This was one of the first major scientific discoveries made in an industrial laboratory. A month later G. P. Thomson independently confirmed de Broglie's theory. He observed the passage of fast electrons with a voltage of up to 30,000 eV through a gold leaf and obtained the interference pattern with rings.²⁹²⁸

Thus, applied electronics and theoretical physics, both the descendant of genus of cathode ray researchers from previous generations, found a common language in experiments at the birth of quantum mechanics. In 1937, Davisson and G. P. Thomson received the Nobel Prize in Physics for their study of the wave nature of electrons; three decades after G. P. Thomson's father J. J. Thomson, who was rewarded for measuring the particle properties of the electrons. But Thomsons, father and son, were allegedly not in furious disputes about the nature of the electrons.

25.6.2 *England: Electron Microscope and Holography*

The Hungarian engineer Gabor studied a high-frequency oscillograph in Berlin between 1924 and 1927 at the same faculty as the Knoll's group later worked. In 1927 Gabor worked at Siemens' laboratories. At the beginning of 1928, Gabor talked in a Berlin café with a fellow citizen from Budapest, Szilard, about the creation and use of an electron microscope.²⁹²⁹ Soon, both Hungarian Budapest Jews Gabor and his two years elder Szilard left their ungrateful German fatherlands metamorphosed in Nazi-stan.

²⁹²⁸ Thomson, 1970, 158–160.

²⁹²⁹ Knoll, Ruska, 1932 638, 642; Gurikov, 1985, 59; Gloede, 1986, 173.

²⁹²⁷ Knoll, Ruska, 1932, 661, 650; Gloede, 1986, 176–177.

In 1947, as a researcher at English subsidiary of the General Electric Company the Thomson-Houston Company in Rugby, Gabor experimented to increase the resolution of the electron microscope, which was theoretically 0.4 nm and practically only 1.2 nm (Figure 25-3). Due to incomplete optics, it was not possible to achieve resolution comparable to de Broglie's wavelength of fast electrons, which is 1/200 nm wide. Therefore, in addition to the amplitude, Gabor wanted to write a wave phase, filmed with a coherent jet of electrons. The idea was interesting enough to enable Gabor to experiment for the Metropolitan Vickers, which produced electron microscopes. On 15. 5. 1948 Gabor's first report indicated that the new reception could be used in electron microscopy. Gabor developed his holography electron microscopy with various colleagues during the next five years. Unfortunately, he had to abandon his "premature" efforts as electron microscopes needed another two decades to reach the theoretical limits of their resolution restricted only by spherical aberration. Improving resolution for a factor of two would only allow observation of atoms in such perfected microscopes, which Gabor predicted as a new possibility of "holographic electronic spectroscopy" in 1972.²⁹³⁰

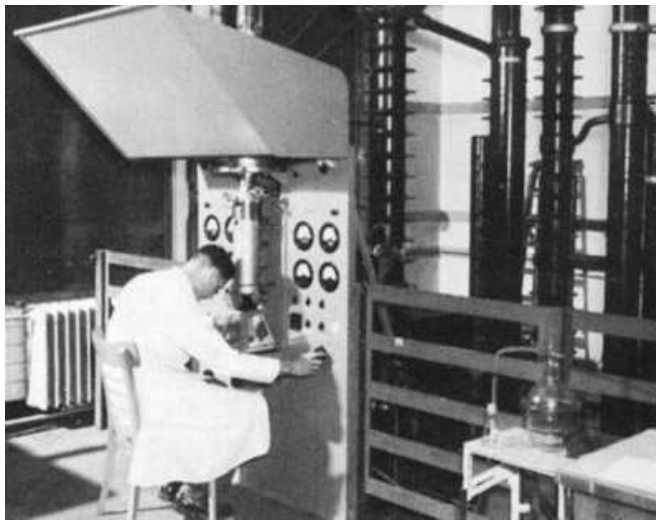

Figure 25-3: Philips' 400 kV electron microscope from 1947

After 1962, the invention of the laser enabled the use of Gabor's ideas in laser holograms. In 1971, Gabor received the Nobel Prize for his invention of holography.

25.7 Engineer Strojnik with the First Ljubljana Electronic Microscope

The dream of observing atoms has always been endorsed by both Ljubljana erudite and other scientists all over Europe. Vernon Ellis Cosslett (* 1908) has read Knoll and Ruska's discussions as a PhD student at the University of Bristol after graduating from Physical Chemistry in 1932. As a young researcher, he wished to observe biological samples through an electron microscope. During the war, he worked at Oxford, and in 1946 he came to the Oxfordian Cambridge competitors just before the English brought a seven-year-old Siemens electron microscope there as a kind of military refund. The American electron microscope RCA EMB has been used since 1942, so they quickly found themselves at home on their new German device.

Cosslett and colleagues soon developed Cambridge into the center of electron microscopy. In the summer 1956 they organized the first international conference "X-Ray Microscopy and Microanalysis". In 1960 they published the first transparent reviews book on X-ray microscopy.

Among the many students of Crosslett's work, the Slovenian Aleš Strojnik (* 1921 Ljubljana; † 6th November 1995, Arizona) was among the best. The Carniolans are everywhere where something important is going on. In the May issue of Physics Today, Alojz Paulin, one of the admirers of the Strojnik's successes, read the sad news of Strojnik's death. The death of Slovenian scientist happened in the former Wild West in the US, just where Karl May's (1842–1912) Winnetou and his men were going to eternal hunting grounds.

Already in Strojnik's cradle was a talent, since he was the son of a professor at Technic faculty in Ljubljana Romeo Fakin who changed his surname to Romeo Strojnik. In 1939 Aleš Strojnik graduated from the classical Grammar school (gymnasium). In the same year, he enrolled in the Department of Mechanical Engineering at the Technical Faculty of the University of King Aleksandar in Ljubljana. In 1941, he enrolled in the Department of Electrical Engineering, where he graduated during the war in 1944. He defended his doctorate in aerodynamics in 1953 under

²⁹³⁰ Gabor, 1948, 778; Gabor, 1972, 302–303.

supervision of the professor Kuhelj. In 1955, Strojnik became a lecturer-docent. He was promoted to the status of an assistant professor in 1960, and in 1969 he was a full-time professor at the Faculty of Electrical Engineering in Ljubljana. By his example the Faculty of Electrical Engineering has turned from the College of Thinkers and Philosophers to the faculty of technicians and inventors.

Aleš Strojnik was born in Ljubljana in the family of professor of mechanical engineering who changed his funny surname Fakin into more appropriate Strojnik. As a professor at the Faculty of Electrical Engineering in Ljubljana, he trained numerous domestic experts in electron microscopy. In 1969, Strojnik became a professor of physics and astronomy at State University of Arizona in Tucson, where he compiled a transversal linear microscope. He had already dealt with airplanes during the war as A. Kuhelj's assistant. Therefore, Strojnik successfully established himself in American networks of designers of planes. He did not stay only in vacuum technique, but he was mainly engaged with much more enthusiasm and even greater success in designing his aircrafts. His Slovenian knowledge was celebrated all over the Earth, and a bit above it. He compiled one hundred and fifty original plans for small planes, including an interesting model S-2A. He received numerous awards, including the Otto Lilienthal Prize named after the most famous German glider pilot of a heavier-than-air aircraft that is supported in flight by the dynamic reaction of the air against its lifting surfaces. In 1988 Strojnik got the Paul E. Tuntland (1922-1950) Memorial Award. He has published several books on light aircraft translated into many languages.

In Ljubljana, Strojnik made some decisive improvements. He introduced the first masters' degree postgraduate studies in Ljubljana, Yugoslavia and in Central Europe. In 1962, at the Faculty of Electrical Engineering of University of Ljubljana the students completed their first Masters' degrees of Science in Yugoslavia. They were educated in the field of electron optics and vacuum electronics. Later, the similar course of study was continued by Paulin in FERI in Maribor. In 1952, Strojnik received a five-month scholarship from the British Council for electron

microscopy specialization at Cosslett's labs in Cambridge. At that time, there were no electron microscopes in Yugoslavia, since the price of that top device was about 30,000 US dollars. After Strojnik's return, the Faculty of Electrical Engineering of the Technical College of Ljubljana accepted the construction of an electron microscope in its work program in 1953.

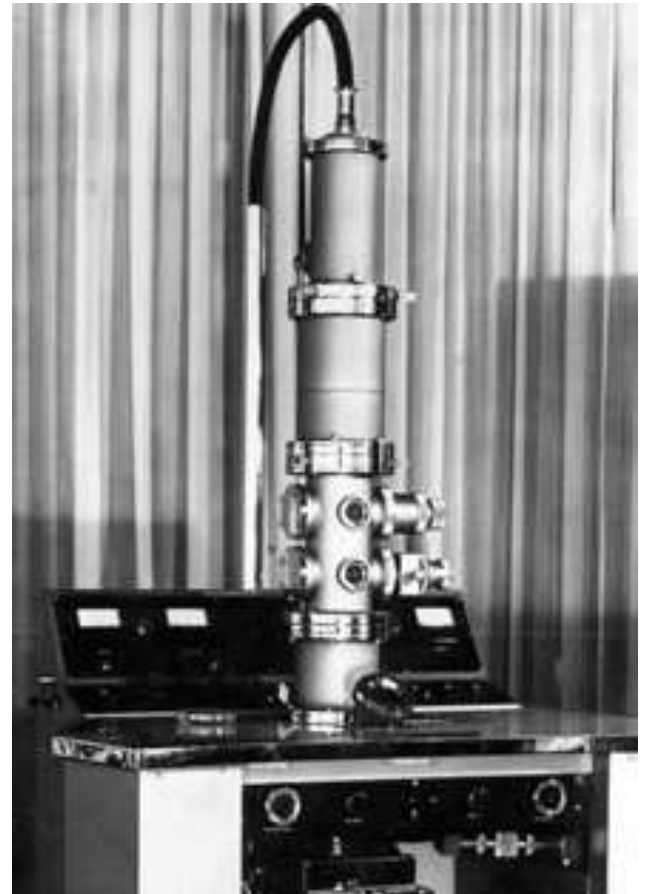

Figure 25-4: The first Slovenian electron microscope, which was created fifty years ago according to the plans of prof. Aleš Strojnik.

The first electron microscope of domestic production with 50 kV and a resolution of 5-2.5 nm was put into operation in the spring of 1955 (Figure 25-4), and the LEM-2 microscope with 50 kV began to work at the Metallurgical Institute in Ljubljana in the spring of 1958. In an exceptional case, it reached a resolution of about 1.7 nm. Strojnik's group was the only one in Yugoslavia to develop an electronic microscope, if we excluded an unsuccessful experiment in Zagreb. During this time, only two microscopes of foreign manufacture were in Yugoslavia. In October 1954, the Material Research Laboratory at the Jožef Stefan Physics Institute received the electronic microscope of the firm Carl Zeiss. At the Ruđer Bošković Institute in

Zagreb, they focused mainly on biology. In 1958, besides LEM-2 at the Metallurgical Institute in Ljubljana, an electronic microscope was obtained at the University of Belgrade. In the 1970-s, there were about 2000 electronic microscopes around the world, with magnifications up to two million times. With them, it was already possible to observe individual large molecules in the cells, and there was no longer a "doubt that some atoms can be seen".²⁹³¹ The late Ernst Mach would certainly have been angry, but the atoms (indeed) finally become a reality.



Figure 25-5: An analytical transmission electron microscope Jeol JEM-2010F at IJS

Strojnik educated numerous domestic experts in electron microscopy. Two rectors of the University of Ljubljana, several deans, university professors and other scientists came out of the Strojnik's school, among others Prof. dr. Navinšek. Today, of course, Strojnik's achievement contradicts the modern European doctoral studies without a master's degree.

Strojnik advanced the Slovenian technique. He built the first electron microscope in Yugoslavia, in the Balkans, in Central Europe with small resources.

The late Ernst Mach would surely have been angry with Strojnik if at that time could still visit his parents under Slovenian Gorjanci mountain range, but the atoms become a reality.

Cosslett's school soon began to collect fruits. In 1982, former team member of viruses and DNA pioneer Rosalind Franklin, the Jewish Aaron Klug from the Laboratory of Molecular Biology at the Medical Research Center in Cambridge received the Nobel Prize in Chemistry for the development of a crystallographic electron microscope.

In 1986, Ruska received the Nobel Prize for his "invention" of an electron microscope. The German Gerd Binnig and Swiss Heinrich Rohrer shared a prize with Ruska for their invention of the tunnelling linear microscope. Four years earlier, Aaron Klug from the Laboratory of Molecular Biology at the Medical Research Center in Cambridge received the Nobel Prize in chemistry for the development of a crystallographic electron microscope. The engineer Strojnik's achievements were not that high, but he was a great technician and a scientist inside the Slovenian networks.

Unfortunately, the politicians of that time closed Strojnik's way to the membership of SAZU Academy. For Slovenes' spirits and hearts, a philosophical line of merit was and still is much closer than any productive technical direction. We see this at every step. In 1928, Professor Marij Osana set up the first transmitter in the Balkans in Domžale. At the 50th anniversary of Slovenian TV broadcastings, Slovenians remembered all announcers and other faces from small TV screens; but they almost did not mention Osana, who made all that possible. In Slovenian encyclopaedias, most artists and writers are mentioned, while many technicians and businessmen are simply forgotten. This mentality separates Slovenians from their western and northern neighbors, where the scientists are in the first place, even before the imperial dynasties, inventors and businessmen.

²⁹³¹ Strojnik, 1955, 214.

26 Major Scientific Uses of Vacuum Technologies - Accelerators

26.1 Accelerators: from Ideas to First Performances

Almost a century ago, there was a tough competition in accelerating the protons to the energy needed to break the nucleus of the atom. We can have those events for the beginning of the golden age of high-energy physics. Rutherford used only a few ropes and waxes for his famous experiments, but so much more reason and imagination. Later, accelerators developed into one of the most demanding technologies in the world.

26.2 Pre-history

The art of production of accelerators was born from the older technology of high-voltage electrostatic devices and vacuum pumps. Hauksbee compiled the first ancestor of tools of these sorts in 1705 or a year later. He rotated his emptied round glass container around its axis. When he rubbed rotating bowl against the fur, he got enough voltage to notice the weak scarlet glow inside the bowl. The glow could have been caused by the electron fluorescence or, more likely, by the ionization of residual gas in incomplete vacuum.

In 1784, the Dutchman van Marum received more than half of meter long nice spark with a magnificent electrostatic machine, which was set up in a large hall at Teyler Museum in Haarlem in Holland. In 1897, JJ Thomson attributed cathode ray properties to electrons as the first one who realized that he was breaking atoms in his experiments.

In 1911 in Manchester, Rutherford published the results of scattering of α -particles by atoms. Six years later Rutherford succeeded in his first artificial change of the nucleus (Figure 26-1). The nitrogen was bombarded with 5 to 8 MeV α -particles from radium and thorium to get protons.²⁹³² In 1925, near the orbit of proton, he

²⁹³² Livingston, Blewett, 1962, 4.

observed a short trace of isotope ^{17}O in the Wilson's cloud chamber.

After the First World War, X-ray researchers developed devices in which the particles reached 100 to 200 keV. Due to the problems of insulation and discharges, it was not possible to achieve higher energies comparable to the radiation energy of radioactive elements used by Rutherford. Overcoming these problems has become one of the main orientations of researchers. It was suggested that it would soon be possible to study systematically or break down the recently discovered nucleus of the atom in the high energy accelerators. Several US researchers have reported that they broke the nucleus successfully, among them Millikan, who considered that he and his student George Winchester extracted hydrogen atoms from aluminium and other metals with strong discharges in a vacuum in Chicago as early as in 1912. To continue such experiments, Millikan switched to Caltech in 1921, where he measured with a voltage of one million volts. In 1923, the Slovenians read: "The "Stone of the Wise Men" we found. We can arbitrarily fragment the atoms."²⁹³³

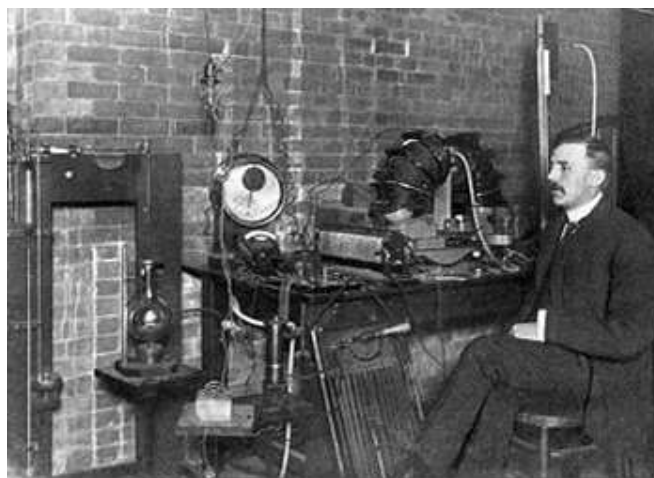

Figure 26-1: Rutherford with his tools²⁹³⁴

26.3 Who Will Break the First Nucleus?

Orlando Lawrence was a grandson of a Norwegian teacher who emigrated to Madison in Wisconsin. He was born in the small village of Canton, South Dakota, on 8 August 1901. He graduated from the University of South Dakota in 1922, and three

²⁹³³ reprint: Čermelj, 1980, 111.

²⁹³⁴ Campbell, 1998, 35.

years later he received his Ph.D. in Yale. In 1927 he worked at the University of California at Berkeley, where he remained in a pleasant university town until his death. One spring evening in 1929, he accidentally came across a discussion at the Archiv für Electrotechnik exerted from the doctorate of Norwegian Widerøe, who studied in Germany. Widerøe's criticism of Gaede's claim that the ultimate performances of vacuum pumps are limited was approved by Rogowski who invited Widerøe to his institute in Aachen in May 1926. Since 1932, Widerøe has worked with a branch of Swiss-based Brown-Boveri Company in Oslo, since 1946 in Baden in Switzerland, since 1952 at CERN and after 1959 at DESY in Hamburg. Lawrence did not look at Widerøe's writing in detail in the first place until his attention was drawn to his sketch of the measuring device. Then a Norwegian spark flourished among Scandinavian compatriots. The idea of the Swede Gustav Ising from 1924, which was used by Widerøe four years later, has gradually enabled betatron and resonant linear accelerator. It was not completely new invention. The president chairman of the MIT Compton compared that acceleration method compared a child on the swing. He knew that the swing could reach very high altitudes, although we periodically push it only by a small distance. According to the idea of Ising, speed should be increased linearly with energy. Widerøe succeeded in experimenting with resonant acceleration of sodium and potassium ions. Between three cylindrical electrodes he placed a 15 cm long gap. The oscillator has been adjusted to a frequency slightly above 1 MHz with differences of potentials of 20-50 kV. In such a linear accelerator he accelerated the ions to energies that corresponded to the doubled value of the selected voltage. He thus confirmed the possibility that with a low voltage we can increase the velocity by adding it at the correct resonant intervals.

Lawrence has long sought path to avoid high-frequency currents in his complicated device, in which he accelerated the projectiles to huge speeds in emptied containers. Widerøe's idea fell to fertile soil. In a few minutes, his fellow Norwegian Lawrence drew a camera and wrote equations. The next day he told his friend about the invention. He thought of circling an electrically charged missile in a very strong magnetic field. The first shot had a strong accelerator burst in the recipient in an empty space in the form of a pan, equipped with a lid.

Lawrence then accelerated it with repeated electric shocks, causing the projectile to circulate in ever-wider circles at ever-higher speeds. Finally, the projectile hit the edge of the recipient and reached the reception space at the passage through the crack to bombard the atomic nuclei there. Lawrence set the magnetic field so that the projectile flew precisely at moment when the alternating current changed its direction and was ready to accept the next shock. High frequency fluctuations were used to increase the velocity of the projectile. He hoped that with the thousand times used thousands of volts he would achieve the same effect as if using one million volts at once. He used the same great idea of resonance as did Tesla for his tower two dozen years earlier. Except that Lawrence was a mainstream guy.

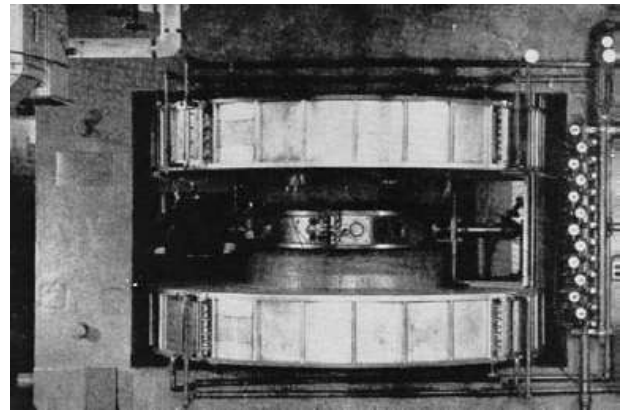

Figure 26-2: Lawrence's cyclotron for 16 MeV²⁹³⁵

In January 1930, Lawrence constructed the first resonance accelerator, later called cyclotron. Between the halves of the electromagnet, he placed an exhausted container of diameter 10 cm. He installed two isolated D-shaped electrodes connected to the high-frequency alternating current. Other parts of his device were made of glass, which was sealed with a wax. With the help of his another graduate student of Scandinavian genius Niels E. Edlefsen (1893 Cache, Utah-1971 Davis, Yolo, California), he got a resonance. In September 1930, at NAS in Berkeley he publicly reported for the first time on his cyclic magnetic resonance device and published a discussion in the journal Science together with Edlefsen. Lawrence's cyclotron used new discoveries about the electron, just like his contemporary electron microscope. Initially, it was aimed at exploring the structure of atoms like its later namesake nuclear magnetic resonance.

²⁹³⁵ Livingston, Blewett, 1962, 133.

After his first model made of glass, Lawrence assembled another similar metal device with the help of his new PhD student Livingstone. With a 2000 V voltage, they were able to accelerate hydrogen ions to 80 keV energies. Livingston proved the utility of the principle of cyclotron resonance in his doctoral thesis on 14. 4. 1931.²⁹³⁶

In February 1932, Lawrence built a model worth US \$ 1,000. It was 30.5 cm wide with a 1.2 MV acceleration voltage (Figure 26-2). In the summer of 1932, he was the first to break the lithium nucleus in the New World. The following year he was the sole US participant of the Solvay Conference, and in 1939 he received the Nobel Prize in Physics. The focus of mainstreams was gradually shifting across the big blue water nicknamed Atlantic.

In 1932, Chadwick discovered the neutron in Cavendish's laboratories, thereby increasing the number of elemental particles. But American of Scandinavian genus prospered the most, just like the Hungarian Martians a decade after them. Carl David Anderson was born to the Swedish parents in New York in 1905. On August 2, 1932, he spotted an electron moving opposite to the expected direction in the film shot at Wilson's cloud chamber in Millikan's laboratory at CalTech. In September 1932 he published the discovery of a particle, which P. A. M. Dirac had previously predicted as a positron. For their discoveries, Chadwick and Anderson received their Nobel Prizes in 1935 and 1936.

26.4 The English Won the Match

Lawrence and Livingston were the first to accelerate protons over 1 MeV; but they did not break the atomic nucleus as the first in the race. This happened in the Cavendish Laboratories to Cockcroft and his collaborator the Irishman Walton. Their boss the director Rutherford initially opposed expensive investment in accelerators at Cavendish's laboratories. He was drawn by the romance of the past generation, when it was possible to detect important physical phenomena with primitive tools. In 1927, in his speech before the RS, he already announced the devices with 300 and 900 kV, which will allow studies of the structures of the atomic nucleus. At the end of

1928, he ordered Cockcroft to start work on a high-voltage accelerator, where Walton joined him the following year. The first experiments were made in March 1930.

Over two years, Cockcroft and Walton rearranged the device to bomb the lithium nuclei with protons. At 125 kV, they already noticed a lot of strong scintillations. At 400 kV they spotted several hundreds of them every minute by the current of protons of a few mA. Due to sparking, they could only keep up to half a megawatt, with other sources up to 600 or even 700 kV. However, Rutherford advised the experiment. He believed in Gamow's theories (1928) and in ideas developed next year in 1929 by W.L. Bragg's Manchester student Ronald Wilfred Gurney (Wilfrid, 1898 Cheltenham in England-1953 New York) and later Manhattan project official almost turned McCarthyism's victim Edward Uhler Condon (1902 New Mexico-1974 Colorado). According to them 0.5 MeV or less would suffice for the breakdown of lighter nuclei, although other researchers predicted penetration into the nucleus only at voltages of about 1 MV.²⁹³⁷

Englishman **John Douglas Cockcroft** began working as an electrical engineer and after obtaining mathematical scholarship in Cambridge, he studied under Chadwick's leadership.²⁹³⁸

After the bombardment of lithium nuclei with protons, the Cavendish Laboratory produced particles with a maximum reach of about 8 cm. Those proved to be α -particles, which was confirmed by Wilson's cloud chamber images. The nucleus of the atom was broken, alchemy became a reality. On 20 April 1932, Rutherford reported on the successes of Cockcroft and Walton. The English got a game and showed that there is some important physics insight needed, not just the power of the costly tools used. They also found a mass defect of 0.018574 a. m. e., which corresponded to the predictions of Einstein's equation. Similar experiments were carried out with boron, fluorine and aluminium. The scintillations were also obtained during the experiments with beryllium and carbon, but not

²⁹³⁶ Livingston, Blewett, 1962, 134.

²⁹³⁷ Livingston, Blewett, 1962, 4.

²⁹³⁸ Brown, 1997, 74.

with oxygen and copper in the proton energy up to 4 keV.²⁹³⁹ The similar transmutations of atoms were studied by Lawrence in 1935.

As a result, the Cockcroft-Walton's voltage multiplier could reach 750 kV. Later, the firm Philips in Eindhoven used their plans to install a device that reached 1.25 MV led in Cavendish Laboratory. It turned out that this is indeed the maximum that an accelerator of this type can achieve at normal pressure.²⁹⁴⁰ Rutherford received the Nobel Prize in chemistry in 1908, and in 1951 Cockcroft and Walton shared the Nobel Prize in Physics for their success in the development of accelerators. Rutherford's prize was accompanied by his robust joke: "I have dealt with many different transformations with various periods of time, but the quickest that I have met was my own transformation in one moment from a physicist to a chemist!"

26.5 Accelerators Turn into "Big Science"

In 1936, Lawrence became director of Radiation Laboratory. William Brobeck was the first professional engineer to start his job at Lawrence's lab in 1938. He made every effort to change the previous technology of "thread and wax" into modern engineering practice. In the 1930s, Lawrence set up a 70 cm centric cyclotron giving some μA of deuteron currents with energy of 5 MeV or helium nuclei with energy of 10 MeV. The large electromagnetic pole had a diameter of 114 cm and was buried in the ground up to the height of the kitchen stove. The control room was 5 m higher, and the operator had an additional protective envelope. In 1939, Lawrence set up his 70 cm cyclotron in a larger 1.5 m cyclotron, set for medical examination of cancer. The larger cyclotron weighted 220 tons and it gave a deuteron current of 10 mA with energies 16 MeV or a current of 1 mA of helium ions with energies of 32 MeV. In July 1941 Lawrence began building a 24-side structure in Berkeley. It was 30 meters high, 50 meters in diameter for the supposed more powerful cyclotron. The work continued after the attack on Pearl Harbor on December 7, while the military activities could also be expected which forced Lawrence to convert his old 37-inch

cyclotron into a giant mass spectrometer needed for Manhattan bombers. Lawrence's 467 cm large synchrocyclotron was completed only after the war in 1949. It cost 1.8 million dollars and reached 340 or even 380 MeV. A multimillionaire banker and scientist Alfred Lee Loomis (1887 New York-1975 East Hampton New York) achieved the great merits by collecting the necessary money. To exceed the threshold energy of 100 MeV resulting from the increase in the mass of accelerated particles, they used the idea of Lawrence's Californian co-worker Edwin Mattison McMillan (1907-1991) and the Russian inventor of microtron Veksler from 1944 and 1945 for the synchronization of magnetic and electric fields. Thus, constant ion acceleration in the synchrocyclotron was achieved.²⁹⁴¹ In 1951, McMillan received half of the Nobel Prize in Chemistry for his discovery of transuranic elements.

26.6 Van de Graaff Generator

26.6.1 Early Ideas

In 1749, Franklin supposedly performed his dangerous experiments with lightning, even if some recent studies describe his work more like thought experiments. Less fortunate was the

Russian Academician Richman in 1753 in Petrograd.²⁹⁴² The Carniolans were not lagging much behind, as Ambschell described the lightning that hit the monastery church in 1782, 3 miles south of Ljubljana. The Carniolan Hallerstein participated in the first experiments with the ancestor of the electrophorus in Beijing (Peking) in the 1750s, and in 1833 Hummel published a paper about a simple electrophorus charged by friction.²⁹⁴³

26.6.2 The Ljubljana Van de Graaff

On 27. 11. 1954, a century after the departure of Hummel from Ljubljana to Graz, the electric part of Van de Graaff generator of Slovenian domestic production was used at the IJS in the laboratory of Edvard Cilenšek "for the construction and

²⁹³⁹ Staroseljskaja-Nikitina, 1967, 258–261.

²⁹⁴⁰ Livingston, Blewett, 1962, 5.

²⁹⁴¹ Lapp, 1960, 183.

²⁹⁴² Priestley, 1775, 1: 417–418.

²⁹⁴³ Hummel, 1833, 213–235.



Figure 26-3: Van de Graaff generator at MIT, below three Van de Graaff's co-workers²⁹⁴⁴

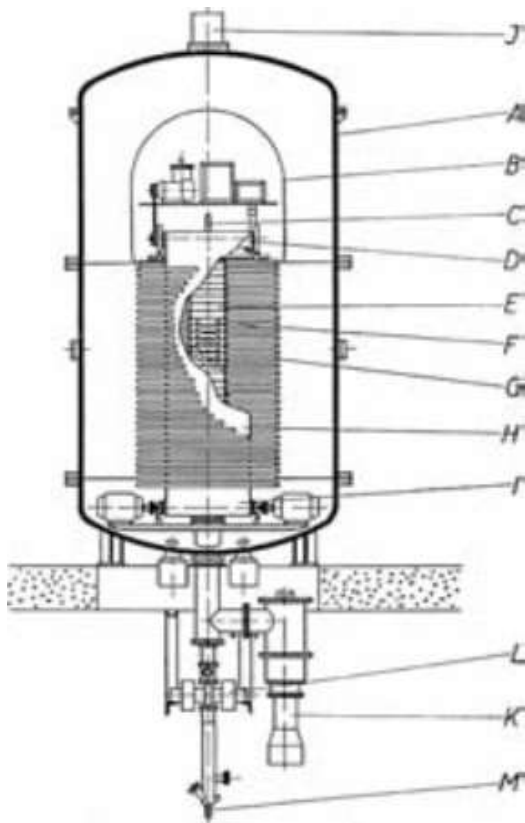

Figure 26-4: The cross-section of an electrostatic accelerator for two million volts, which started in the IJS in Ljubljana half a century ago.²⁹⁴⁵

²⁹⁴⁴ Livingston, Blewett, 1962, 30.

²⁹⁴⁵ Cilenšek, 1958, 393.

maintenance of accelerators". The native scientists designed their own plans, constructed, assembled and tested individual parts, and therefore continued Hummel's efforts (Figure 26-4).

The whole build-up of the accelerator lasted just over four years from 1953 to 1957. They built a closed-type device that operated under a pressure of 10 bar of nitrogen. They could direct their elementary particles to the target by their range between 200 kV and 2.3 MV. For a high vacuum in the acceleration tube, a diffusion pump with a pumping velocity of 500 l/s was used. In May 1956, the beam was accelerated for the first time through a tube with a voltage of 2 MV at a pressure of 8 bar. In March 1961, the accelerator for 1.8 MeV was completed and since then it has been in almost constant operation (Figure 26-5).

In 1963, the structure of the levels in lighter elements was investigated by using the reaction (p, γ) with Van de Graaff. However, that device was already outdated for promising research in nuclear physics compared to betatron or neutron generator designed at Cavendish in 1930s.



Figure 26-5: Electrostatic Van de Graaff generator for two million volts with an open boiler and a high-voltage electrode at the IJS in Ljubljana²⁹⁴⁶

²⁹⁴⁶ Cilenšek, 1958, 395.

26.7 Electron Accelerators

The first electron accelerator the "cathode ray tube" was used for the first time a century and a half ago. In the 20th century, the electrons were first accelerated with Van de Graaff devices, which could not exceed few MeV. The cyclotron was not useful because the mass of the accelerated electrons began to increase noticeably at a level of few 10 keV.

Therefore the American engineer Joseph Slepian (1891 Boston-1969) at Westinghouse and Wideröe did not achieve much success in accelerating electrons in the 1930s. In 1933 Steenbeck wrote the mathematical conditions for field stability in the accelerator at Siemens Röhrenwerk labs in Berlin just while Hitler ascended to his throne²⁹⁴⁷ to enable Steenbeck's work for von Ardenne's part of Soviet nuclear bomb a dozen years later.

The American Kerst of the Illinois University constructed a betatron using the law of electromagnetic induction and reached 2.3 MeV for GE in 1940. He used Wideröe's idea of a "beam converter" from 1928 for his magnetic induction part of betatron. However, Wideröe did not yet know the rules needed to keep the electrons in orbit.²⁹⁴⁸

The Carniolans were fast in the game. In the summer of 1954, betatron was purchased at the IJS. In 1956 Darko Jamnik succeeded in achieving 20 MeV energy stabilization at 5 keV. Thus, Slovenian betatron in the range of energies of up to 30 MeV was the most accurate device in the world for the exploration of a nuclear photoelectric effect.

²⁹⁴⁷ Siemens, 1957, 2: 195.

²⁹⁴⁸ Livingston, Blewett, 1962, 134.

27 Vacuum for Entertainments - Television

27.1 Cathode Ray Tubes and other Vacuum Elements for Television

The developed telegraphy seemed to be able to transfer images to distances that go beyond physiological options. In 1843, Wheatstone's competitor the Scotsman Alexander Bain (1810-1877) described a system for transferring images, especially chemically colored portraits. The current between the electrodes applied on the image obtained information about the drawn image. Bain's telegraph with the corrections of the Viennese university mechanics designing working Baumgartner's magnets and Ettingshausen's photographic apparatuses Johann Michael Eckling (Eckling, * 1795 Vienna; † 1876 Vienna) was used in Austria since 1847, until the introduction of Morse telegraph.²⁹⁴⁹

In parallel, they developed other methods for chemical detection and electric transmission of the recorded data, including Frederick Collier Bakewell's (1800-1869 North London) Londoner telegraphic facsimile in 1847 commercialized only by the Florentine university professor priest Caselli with a little help of his Grand Duke Leopold II and Parisian emperor Napoleon III. The transfer of motion pictures became only relevant after Edison's invention of the cinema at the end of the century.

27.2 Naming of Television

The developed telegraphy seemed to be able to transfer images to distances that go beyond physiological options.

The term television was coined by the Russian Constantin Perskyi (Perski, Константин Дмитриевич Перский, 1854 Tver gubernorate-1906) by his paper read on First All-Russian Electrotechnical Congress (Перви Всероссийский электротехнически съезд) in Petersburg in 1899 and repeated next year under the title The current

²⁹⁴⁹ Šubic, 1875, 21.

state of the matter of the electrification at a distance (television; Современное состояние вопроса об электровидении на расстояние (телевизирование)) on the fourth International Congress of electricity, which was part of the Parisian exhibition in 1900. As the professor of electricity in Artillery academy (кадетски корпус), he was a member of the Institute of Technology in Petersburg, where Rosing and Zworykin later worked. The name was accepted when it was used by Hugo Gernsback (1884-1967), the publisher of the leading American radio news magazine Radio News, in the paper "Television and the Telephot", which was printed in the journal Modern Electrics in December 1909. Gernsback later founded Gernsback Inc., a publisher of Radio-Electronics magazine, renamed in Electronics Now in 1993.²⁹⁵⁰

In 1890, and especially 1903, and 1905 Walther Karl Eugen Stephan (Stephen) in 36th and 38th yearly of Real Grammar school in West Polish Drawsko Pomorskie (Dramburg) entitled his bipartite paper on total 60 illustrated pages "Konstruktion und Theorie eines elektrischen Fernsehers" resembling Nipkow's "Elektrisches Teleskop". In 1891, the chemist photographer Raphael Eduard Liesegang (1869-1947) published the first German book about television "Beitrage zum elektrischen Fernsehen".

The Slovenes under the influence of the German term Fernsehen have long used the term "looking at a distance" or "far-sighted". The prevailing political influence of the German language in Yugoslavia ceased after WW1. When American electronics prevailed in the 1930s, the journal Illustrated Slovenian (Ilustrirani Slovenec) had already used the term television on Codelli and Slišković's page 150 of volume 6 no. 19 on 11 May 1930.

27.3 Sensors and Photocells

In the television, a light signal must be converted into an electric current, which was already transferable to large distance in the 19th century. A. E. Becquerel first observed that light causes electric current in some electrolytes in Paris in 1837 or 1839. Among other things, he discovered a photocurrent from illuminated selenium. In 1851,

²⁹⁵⁰ Fisher, 1996, 29, 45, 92.

Hittorf investigated the effect of heat on the electrical conductivity of selenium. Two decades later in 1873, Willoughby Smith's chief assistant at the English Telegraph Construction and Maintenance Company, Joseph May, accidentally discovered the dependence of light on the electrical conductivity of selenium during underwater cables testing along the southwest Irish coast in the island of Valentia. His experiment table was by the window, and so he could notice that the selenium conductivity increased when the sun was lit up. On February 2, 1873, the head of electrical engineering at the company, Willoughby Smith (1828-1891), wrote to Vice-President of the Society of Engineers, Latimer Clark (1822-1898), to report the phenomenon to the Annual Assembly on the following day. He described an increase in the conductivity of selenium bars by 15% to 100% at illumination as an annoying problem in experiments and did not even mention the discoverer May, who was just Smith's assistant anyway. A few days later, Smith met Edison, who visited London in May 1873. Smith subsequently developed the system of "visual telegraphy", while May investigated the transmission of the image by conductor. That newly recognized phenomenon was used by E. W. Siemens in the invention of the first selenium photocell, which he had, after two years of work, assembled in 1876. The initially undesired affect suddenly became very useful, just like the thin film metallic mirrors deposits in cathode ray tubes in those same times of happy accidental discoveries.

The news slowly penetrated in the USA. In Boston in 1875 or more probably in 1880, George R. Carey (1851 Malden, Massachusetts-1906) first described the television system with the projection of an object's image on a photo-sensitive surface of an insulator that was not selenium, but a silver compound. *Sci. Am.* reported about his work. In 1877, English professors former W. Thomson's assistants John Perry (1850 Garvagh in Londonderry-1920 London) and his Tokyo collaborator William E. Ayrton as the Chair of Natural Philosophy and Telegraphy department of the Imperial university reported in the Londoner *Nature* magazine on selenium cells and Faraday's discovery of the magnet effecting the polarization of light in an article entitled *Lightning Conductors*. In his patents on February 2-10, 1906, December 1, 1906 and 1908 as well as at Parisian demonstration in 1909, Georges-Pierre-Édouard

Rignoux from Surgères in southwestern France with the help of the professor A. Fournier interconnected sixty-four selenium cells on the scanner contact plate for their *téléphote*.²⁹⁵¹

On 27 August 1880 Bell and Charles Symner Tainter (1854-1940 San Diego) used selenium in their photophone. Soon Slovenians read about the discovery in the Slovene language: "If we speak in Bell's elastic mirror, and if the light returns from the mirror back then and into the glass tube, which has sooty in it, our speech is repeated in the sooty of the tube!"²⁹⁵² That was the beginning of Slovene telephony and the foundation of the modern exceptional popularity of mobile phones in the country on the sunny side of the Alps.

The photocell soon surpassed the possibilities of selenium. The photoelectric effect was discovered by Hertz in May 1887. He was exploring the resonance during the rapid oscillations in two Braun's modified coils, which he used as a vibrator and resonator. He noticed that the discharge of the Ruhmkorff induction coil triggered two completely simultaneous electric sparks in both coils. The first was the spark of the inductor's discharge and served to induce the primary oscillation. During experiments, Hertz accurately measured the maximum length of the second, weaker spark in the resonator, which was generated by the induced secondary oscillation. For better observation, Hertz shone the second sparkle with the box; he observed with a surprise that its length was significantly shortened. Moving the box showed that the barrier between the two sparks affects the length of the second spark even at a greater distance between the two sparks. UV light from the first spark caused the second spark, and the obstacle could have interrupted its effect.

Hertz was unable to explain his discovery with electrical charge of the obstruction, as the effect was observed both behind the barriers of conductors and behind the insulators, but not behind the metallic grid. He thought that the effect of shortwave UV light, which is absorbed by most solids, while he was also able to prove the effect of refraction and reflection of UV light. Hertz

²⁹⁵¹ Israel, 1998, 88, 483; Friedel, Israel, Finn, 1930, 12-14; Borchardt, 1930, 95; Swift, 1950, 21; Zworykin, Ramberg, 1950, 1-2; Zworykin, Ramberg, Flory, 1958, 5; Fisher, 1996, 9-11, 13.

²⁹⁵² Šubic, 1882, 535-538; Klemenčič, 1881.

measured in a rather wrapped circumstance, therefore, in its report, he carefully preferred to avoid the explanation of the photoelectric effect (Figure 27-1).²⁹⁵³

In 1889, Geitel and Elster got their photoelectric images at the Wolfenbüttel Gymnasium. They used photocathode made of potassium or sodium amalgam illuminated with visible light through anode in the form of a ring. They illuminated their cesium photocathode by UV light. The following year, they sealed their device a glass vacuum tube, thus obtaining the first modern photocell which Rosenthal first used for his "optical telegraphy".

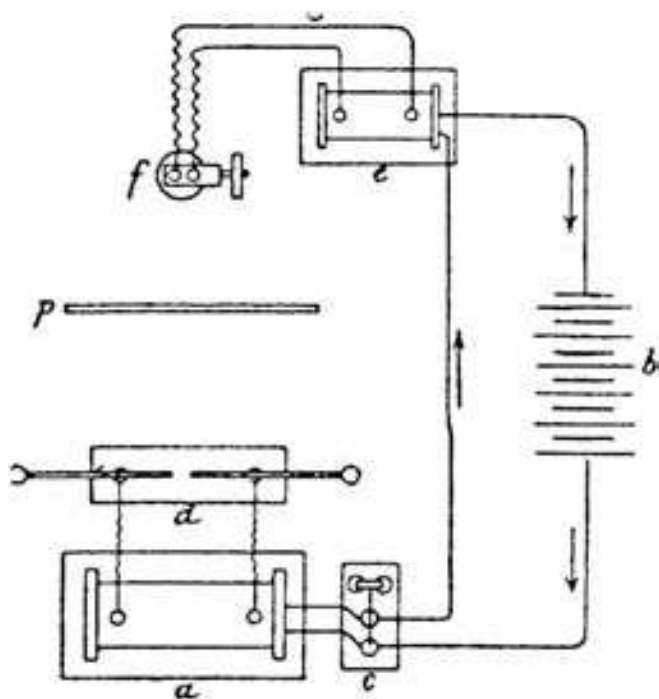

Figure 27-1: A schematic diagram of the device which Hertz used to discover his photoelectric effect²⁹⁵⁴

In March 1889, Hertz's assistant Lenard and the leading Heidelberg astronomer photographer Maximilian Wolf combined the idea of Hallwachs designed in 1888 for the emission of UV-light electrons and Nahrwold's study of the sputtering of metallic cathodes in a vacuum from 1887 and 1888. In the beginning, Lenard assumed that UV light emits particles with measurable mass.²⁹⁵⁵ On 19 October 1899, as Hertz's successor in Bonn Lenard proved that light breaks out electrons in photoelectric effect. A photoelectric effect takes

place even in the best vacuum, where other known phenomena of discharges are not possible anymore. At ordinary pressures, the breakout electrons stop in the surrounding gas.

Lenard measured the charge, which rays of UV light brought into motion in an empty space at various voltages between the electrodes.

He proved that the electrical forces themselves are not enough to overcome the work function (the electron binding energy) in the photoelectric effect.²⁹⁵⁶ Lenard and J. J. Thomson measured approximately the same e/m ratio for "cathode rays," for particles ejected in the photoelectric effect and particles in the "Edison effect" of annealing metal surfaces.²⁹⁵⁷ In this way they proved that in all cases they are dealing with the same kind of particles for which the name electron was gradually established. They repeated the same old Faraday's approach to show that all kinds of electricity are alike regardless of their origin.

In 1902, with his misinterpretation of the photoelectric effects Lenard impressed numerous German researchers, including Franck and Heinrich's nephew G. Hertz. Of course, Lenard was really very angry when Einstein published the correct theory three years later. No wonder that Lenard then wished to establish the German physics versus the Jewish physics.

27.4 The Amplifiers and Triode

Geitel, Elster and Guthrie (1873) investigated the thermionic emission, which was later named after Edison.²⁹⁵⁸ Photometry has got a serious momentum barely with the Edison's inventions of the bulb. Like Crookes, Edison has occasionally been interested in "occult forces". In November 1874, he published his first experiments on the oscillations of various kinds of conductors. In 1875 he patented the discovery of the "etheral force", which was supposed to cause a "revolution in telegraphy". The following year, the discovery was published in the press, immediately after the first US records of similar exploration of the "weak sparks" of German physicist Petrus Reiss in 1875. With his exploration of ether-based forces between

²⁹⁵³ Hertz, 1931/1932, 260–261, 269.

²⁹⁵⁴ *Vakuunist* 16/1 (1996) 20.

²⁹⁵⁵ Lenard, Wolf, 1889, 444.

²⁹⁵⁶ Lenard, 1905, 398, 400–402, 412–414, 416.

²⁹⁵⁷ Weinberg, 1986, 103.

²⁹⁵⁸ Lodge, 1894, 42–45; Zworykin, Ramberg, 1950, 5–6; Borchardt, 1930, 95; Beyer, 1999, 182.

November 1875 and summer 1876, Edison supposedly invented a telegraph without wires.²⁹⁵⁹ The problem about Edison's discovery was summarized by the *Sci. Am.*, where Elihu Thomson and Edwin Houston claimed that Edison's discovery was an induction effect. In November 1878, Edison used a frog's leg as a galvanometer. However, most researchers criticized his assumption of an unexplored natural force resembling Reichenbach's "Od".²⁹⁶⁰ Mihajlo Pupin later attributed a similar discovery to the older research of Joseph Henry, but between 1888 and 1889 Hertz explained it with electromagnetic waves.²⁹⁶¹ However, after the criticism of Edwin Houston and Elihu Thomson in a more scientific *Journal of the Franklin Institute* the 28 years old Edison put his discovery aside as he was also pressed by his senior business colleagues who requested Edison's work on telephone patents. Later, Hertz in main points confirmed Edison's ideas, but Edison was leaning on the disputed Reichenbach's OD²⁹⁶² while unlike his opponents Edison was less inclined to follow the requirements of the scientific mainstreams. Of course, Edison was no less versed than his competitors and had one of the best equipped labs in his famous Menlo Park. His German assistant stated in the diary that Edison's abandoned discovery soon became a base of wireless communication: therefore later, Edison regretted that he did not insist on the development of his discovery, whose cream was picked up by Hertz instead.²⁹⁶³

In 1880 and 1883 Edison set up an additional third insulated electrode during the study of the blackening of the bulbs between the electrodes. He discovered that the current flows through the vacuum from the third electrode to the filament, if the first electrode is positive and the other is negatively charged. The phenomenon became known as the 'Edison effect'.

²⁹⁵⁹ Ian Wills, Edison and science, in: *Studies in History and Philosophy of Science*, 2009, 40: 159.

²⁹⁶⁰ Edison, 1991, 668–691; Nye, 1983, 38.

²⁹⁶¹ Israel, 1998, 111–115, 469–470.

²⁹⁶² Wills, *ibidem*, 158.

²⁹⁶³ Lambert has not yet known cancerous skin damage with sunlight since they were not researched before the year 1900, when the discovery of Niels Ryberg Finsen (* 1860; † 1904) won the Nobel Prize in Physiology and Medicine in 1903. Finsen's work *Om Lysets Indvirkninger paa huden* (on the effects of light on the skin) was printed in 1893, and three years later the Finsen's classical work *Om Anvendelse...* saw its white day.

In 1883 in a patent and in a lecture at an exhibition in Philadelphia, Edison described an "ethereal force", causing the charged plate to discharge near the incandescent bulb. The insulated platinum electrode was placed at the distance of 1.35 cm from the arc between the glowing filaments of the charcoal in the bulb. Edison used the galvanometer to measure the current between the platinum plate and one of the wires. He supposed that the charged particles of air or charcoal abandoned the carbon fiber thread in a straight line.²⁹⁶⁴ The current changed the direction when Edison replaced the electrodes in the bulb and was more often (sic!) larger when the platinum plate was connected to a positive pole. The intensity of the current varied simultaneously with the glowing electrical current through the filament thread. After a while, the current between the platinum electrode and the positive electrode was weakened, and after cooling it was repeated with the previous intensity. He noticed the current through the glass of the light bulb towards the platinum electrode. However, Pupin later complained that the others discovered similar phenomenon before Edison.²⁹⁶⁵

Edison's consultant from London the last Maxwell's Cambridge student Fleming explained "Edison phenomenon" with a thermo-electronic emission in 1890. As technical adviser of Marconi, Fleming invented a thermo-electron emission in the diode as the first thermionic vacuum tube, the precursor of today's radio vacuum tube (valve) in 1904.²⁹⁶⁶ Even if Fleming occasionally cited Tesla as his role model, Fleming in fact served all Tesla's antagonists in a row.

Richardson studied translation at low pressures under the influence of heated metals in Cavendish's laboratory of his teacher JJ Thomson between 1901 and 1903. The phenomenon is difficult, since it depends on level of ionization, temperature, nature of the remaining gas in a vacuum, "past" of a metal, also from its surface.

The conditions are simplified at higher temperatures when the translation depends only on negative particles extracted from the metal. Richardson investigated the temperature dependence of the current between heated metal and a metal electrode nearby. The size of the

²⁹⁶⁴ Edison, 1905, 183–184.

²⁹⁶⁵ Israel, 1998, 469–470.

²⁹⁶⁶ Poljšak, 1931, 35.

current in equilibrium depends on the full number of particles that the surface extracted in the time unit.

At a pressure of 1/600 mm Hg, Richardson received surprisingly high currents up to 0.4 A between electrodes 2 mm away from each other at a voltage of 60 V. The heated platinum, charcoal or sodium electrodes transformed the vacuum into a superb electric conductor according to a thermodynamic equation that connects the current density with the surface of the cathode. Therefore Richardson rejected the possibility of ionizing gas molecules by collisions with heated metal.

According to the theory of German Drude and J.J. Thomson presented at the International Congress of Physicists in Paris in 1900, rapid free electrons were known to translate electricity into metals. Heating increases the average electron velocity. Therefore, several electrons escape from the surface in a process like evaporation, with which Richardson also explained Edison's "etheric force".²⁹⁶⁷

The thermo-emission should result in the escape of electrons with high kinetic energies while most of the early contemporaries searched for the consequences of chemical reactions due to residual gas. To avoid any doubt, both Langmuir and Richardson, who also studied in the United States at Princeton University between 1906 and 1913, measured in as high a vacuum as possible. Langmuir's tungsten experiments in 1913 definitively convinced the critics of Richardson. Richardson then returned to Londoner King's College. For his investigation of thermo-emission, he received the Nobel Prize in Physics for the year 1928.²⁹⁶⁸

In 1906, the Viennese Lieben used Wehnelt's discovery of slow "cathode rays" in his patent application in Germany and elsewhere. He moved the cathode ray with a magnet to change the resistance of the circuit. In the second patent in 1910, the description of his discovery was slightly changed, and in the third patent of the same year, he placed his grid with a low negative voltage to regulate the current in his cathode ray tube. Several German companies exploited Lieben's patent,

²⁹⁶⁷ Richardson, 1905, 581–583, 601.

²⁹⁶⁸ Redhead, 1998, 1398–1400.

which AEG developed into a usable amplifier in 1912.

Independently of Lieben, a freelancer entrepreneur Forest as a former engineer at Western Electric in Chicago, patented "audion" as a Fleming's diode with a grid in the United States in 1907. De Forest's triode was less sensitive to temperature changes than Lieben's, which contained a worse mercury vacuum for his supposed increased amplifying. In 1913 in the Telefunken, Alexander Meissner (Meißner, 1883 Vienna-1958 Berlin) used a triode with a positive feedback to prevent damping.

In the meantime, The Slovenian inventor Julius Nardin nearly invented the triode. Nardin studied physics at Šantel's class in Gorizia and graduated from Boltzmann's class in Vienna in 1904 just before Boltzmann went insane. In 1905, Šantel showed to Nardin a windbreaker with partly movable, resilient flexible blades according to the Ressel's idea. At that time, Nardin was an apprentice practitioner under Šantel's mentoring in Gorizia.

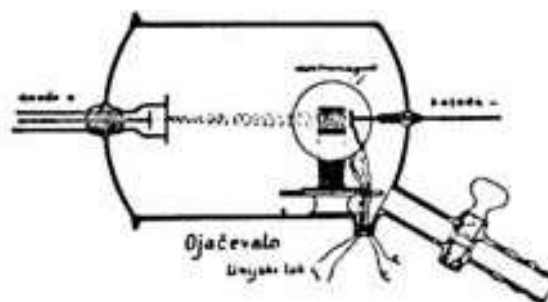

Figure 27-2: Scheme of the amplifier, which was patented by Zei and Nardin in 1913.²⁹⁶⁹

²⁹⁶⁹ Vakuunist 16/1 (1996) 22.

Nardin taught at Real school in Idrija between 1905 and 1912. In 1913, with his friend René Zei from Gorizia he patented in Austria a stand-alone relay for telephones and telegraphs, especially useful for submarine cables (Figure 27-2). Attorney at law René Zei was a relative of the biologist Miroslav Zei (1914 Nabrežina by Trieste-2006) who later served as a university professor in Ljubljana together with Nardin.

They used Wehnelt's generator of slow electrons with a 400 V of voltage in the exhausted pipe with two (or more) equivalent, mutually isolated electrodes. They connected their anodes in the same circuit by winding up their ends outside the cathode ray tube in opposite directions around the iron core of primary coil of the transformer. A shorter anode with a constant current to prevent disturbing interferences could also be placed between the electrodes.

They did not heat their cathode directly, as we do today, but they grilled it with a special plate placed behind cathode in the cathode ray tube. They have placed an electromagnet between their electrodes for directing cathode rays and other (sic!) rays. Nardin twice mentioned "other rays" in addition to the cathode rays, to connect his patent discovery with "discoveries" of a whole series of dubious and less dubious new rays at the turn of the century.²⁹⁷⁰ Caution is the mother of wisdom.

If the electrons fell symmetrically on both parts of the anode, they both got the same potential and the same current through both branches. The effect impact of both currents was balanced and eliminated on the wires wrapped in opposite direction around the coil. When more electrons fell on one of the anodes, so much less fell on the other, and the influence of their currents in the opposite windings of the coil was aggregated and therefore amplified.

While he tried to obtain a patent, Nardin found that his amplifier was four times stronger than Lieben's amplifier developed in the year 1906. The ionization of gases did not disturb his tool as it did Lieben's triode designed in 1910. Unfortunately, Nardin's device could not be tested because he did not have enough efficient vacuum pumps available. Zei and Nardin were not wealthy enough

²⁹⁷⁰ Goldstein's "channel rays", electrically neutral "magnetic rays" of Augusto Righi (1850-1920), "N rays" of Prosper-René Blondlot (1849-1930) and others.

to buy a stronger pump, and therefore without better options they agreed to cooperate with the factory Telephon Apparat Fabrik of E. Zwietusch & Co. from Charlottenburg-Berlin, which joined Siemens and Halske during the First World War. The son of the Milwaukee brewer and mineral water seller Otto Zwietusch (* 1832 Germany), Eduard Otto Zwietusch (Edie, * 1866 Milwaukee-1931 Berlin), studied in Madison and Chicago. In 1888 he returned to the German areas of his ancestors with a great ingenuity to adapt USA patents to German soil especially for the needs of German post Office. As Codelli needed Telefunken to support his ideas, Nardin needed Zwietusch, but Nardin did not earn much by his invention, even though it was a good one.

From 1912 to 1920, Nardin taught at the Classical Gymnasium in Ljubljana with the later famous mathematician Ivo Lah among his students. To be able to exhaust his triode to a sufficiently low pressure, Nardin used his high Grammar school lab to design vacuum pump while using pressure of water drops and adhesion of mercury vapor as he previously learned in Šantel's lab. Unfortunately, the war nullified his agreement with his Viennese manufacturer and producer. That is why Nardin experimented with the electromagnetic deflection of the glowing gas arc between electrodes made from the carbon rod at ordinary pressure with no vacuum available.

On the eve of WW1 Nardin successfully patented his invention in Vienna, and Zei promoted the invention in other countries. Unfortunately, however, they forgot about the USA prestige, just like Codelli somewhat later. When the communications reopened again after the end of the First World War, it turned out that Nardin's invention was overtaken by the de Forest's invention of the triode and with its improvements designed by Langmuir for GE.²⁹⁷¹ The Americans took over the control of modern electronics and a good old Europe remained merely behind them.

Since 1922 Nardin has been a part-time professor of physics at the Faculty of Medicine in Ljubljana, where he founded the Physical Institute. Between

²⁹⁷¹ Julij Nardin (1877-1959), René Zei, Relais für elektrische Ströme, Österreichische Patentschrift Nr. 66604, applied on 13. 8. 1912 with effect granted from 15. 6.1913, issued on 10. 9.1914, 1-2; Nardin, 1929, 44-48; Sitar, 1987, 193; Sitar, 1989, 167; Reich, 1983, 213.

1927 and 1928, he lectured on physics at the Faculty of Arts of the University of Ljubljana. At the Technical Engineering High School, he taught between 1920 and 1947 with a break during World War II.

27.5 Scanners

In 1880 the journal *Scientific American* stated that we must use at least 10,000 circuits for the accurate transfer of thirteen square centimeters of image. For this reason, Bakewell already used the principle of image scanning that the Portuguese Adriano De Paiva (1847-1907), a professor of physics at a polytechnic academy in Porto, first submitted for the use in television in 1878. Before

The German physicist **Paul Nipkow** studied natural sciences and mathematics in Lauenburg in Pomerania to become interested in photography in 1883. For the German patent of his "electric telescope" no. 30105 he received only 25 marks on February 8, 1884. He used Faraday's effect on the selenium cell. In 1885, Professor Dietrich von Engelhardt of noble Baltic-Germanic family reported on Nipkow's discovery in Stuttgart in front of the Association of German Engineers. Nipkow soon abandoned the television research and joined the German Railway Signaling Department in 1886.



Paul Nipkow (* 1860; † 1940)²⁹⁷²

²⁹⁷² Fisher, 1996, 236.

the introduction of the Braun's cathode ray tube, the (microscopic) analysis of the image was used in a spiral-shaped plate, which the German physicist Nipkow patented in his "Elektrisches Telescope" on January 8, 1884. The Habsburgians Jan Szczepanik (* 1872 Ukraine or Poland, † 1926 Tarnów in Poland) and his sponsor the trader Ludwig Kleinberg patented a telescope with vibrating mirrors in 1897, and similar mechanical devices also promised a lot.

After the war, Nipkow retired while his patent became the foundation of new television systems. On 11 May 1928, at a senior age, he watched the exhibition in Berlin. Nobody knew him among visitors, because he had lived in modest conditions for almost half of a century. He raised a lot of attention with his letter to the magazine *Fernsehen*, and soon he was glorified as a German pioneer of television.

In the meantime, the electronic analysis of the image, which later prevailed, was already developed as the competitor of mechanical scanning. In 1935, the Berlin TV station was renamed "Paul Nipkow Fernsehen, Berlin", because under the Nazis, the German Nipkow became the only acknowledged inventor of television.²⁹⁷³

27.6 Cathode Ray Tubes's Electronics

27.6.1 Braun

Karl Ferdinand Braun was born in Fulda in an official family who moved from northern Bad Hersfeld seven years earlier (Figure 27-3). His father was a Protestant, and so he taught his son. Braun's mother was of the Catholic religion, which prevailed in Fulda. The famous Jesuit vacuum researcher Kircher was born 30 km to the northeast in the city of Geisa.

Braun began studying at the Magdeburg University, but soon moved to a more promising Berlin, where he was supported by his 17 years older associate professor Quincke. Among 263 students Braun was one of four who could experiment in the renowned Magnus' Laboratory. On March 2, 1872, few months after Berlin

²⁹⁷³ Fisher, 1996, 19.

became the capital of the newly established German empire, he defended his doctorate in acoustics, while he selected the leading expert Helmholtz as his examiner, just like Hertz did eight years later. During the next two years he was Quincke's assistant in Würzburg, where they replaced Kundt and Kundt's helper Röntgen. The assistant Braun increased his small incomes by publishing satirical poems in the Munich newspaper under the pseudonym Fatty. He retained the artistic vein in older years by drawing watercolors. In Würzburg he continued Stefan's (1865) research on amplifying in semiconductor crystals, and on November 23, 1874 Braun described his "detector", an indispensable rectifier prior to the invention of triodes. A similar hot-wire microphone has been improved by Forbes. The device was later at the eve of WW1 used by Harold DeForest Arnold and his employee after 1913 Irving B. Crandall (* 1890 Chattanooga Tennessee); † 1927) at Western Electric Company labs at New York, transformed into Bell Telephone Laboratories Inc. 1925.²⁹⁷⁴



Figure 27-3: Karl Ferdinand Braun (* 1850; † 1918)

Braun solved his money problems for good in September 1874. He became an assistant lecturer and then a professor at the Grammar School St.

Thomas in Leipzig. Between December 1877 and 1878, he continued Hittorf's (1869) study of the cathode sputtering and electrical conductivity of gases in Geissler's cathode ray tube at the University of Marburg. In 1880 he succeeded Röntgen as associate professor of theoretical physics at the University of Strasbourg, where he experimented in the Kundt's Physics Laboratory together with the guests like Tesla and Tesla's friend Puluj. In September 1883, as a full professor at the Technical University of Karlsruhe, Braun visited an international electrical exhibition in Vienna, whose scientific head was Stefan. Two years later he visited Stefan again Vienna, when Braun and his architect visited the leading European physical institutes to gain experience needed for building Braun's new Physical Institute in Tübingen. Later, Braun's research path met several times with Stefan, for example, when Braun published measurements of the radiation of a square centimetre of glowing porcelain plate compared to platinum and metal oxides in 1887. He did not mention Stefan's law of 1879 in his discussion, although both quoted the measurements of Irishman Tyndall from 1864.

In March 1895, Braun took over the former Kundt's position as director of the Physics Institute in Strasbourg. In 1897, Braun's exploration of the specificity of the translation of electricity in gases²⁹⁷⁵ led to his discovery of the cathode ray tube. Immediately after Roentgen's discovery, Braun joined X-ray research. Unlike other experts, Braun decided to use the cathode-ray tube to "observe the events in an electrical circuit". He started work in the summer of 1896 and commissioned several types of cathode-ray tubes at the firm of Franz Müller (Beckenbauer, 1838-1906) and Franz Müller (1859-1921) who became Geissler's associates in 1874 as well as his successors in Bonn with the firm Dr. H. Geissler, Nachfolger Franz Müller. There they trained their cousin Louis Müller-Unkel (1853 Schmalenbuche (now part of Neuhaus am Rennweg)-1938 Rudolstadt in Thüringen) who moved his manufacture to Braunschweig in 1888/89 to produce photocells for Julius Elster and Hans Geitel and soon also glow discharge tubes for Heinrich Hertz, Philipp Lenard, and Röntgen. In the winter of 1896/97, they brought to Braun's Strasbourg a "half-meter long (glass) tube with a conical end" in which the mica screen was covered

²⁹⁷⁴ Beyer, 1999, 178.

²⁹⁷⁵ Braun, 1896, 688, 691–692.

with luminescent paint. In Bonn F. Müller precisely designed it with millimetre accuracy according to Braun's plan: "... The glass wall should be as uniform as possible and without cramping, with a phosphorescence screen through which glass and mica we could see the fluorescence spot of the cathode rays."

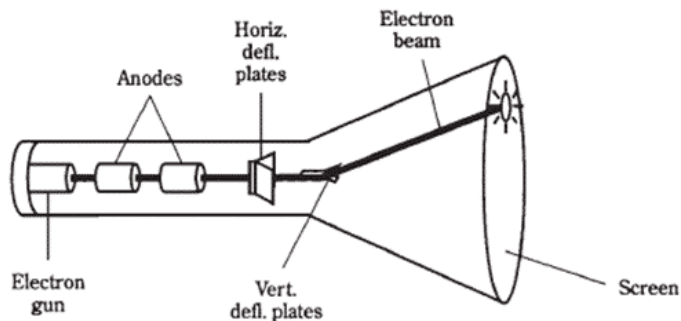

Figure 27-4: Braun's cathode ray tube scheme²⁹⁷⁶

They placed the cathode ray tube on their working table, connected it to electricity and started the vacuum pump. After the high-frequency generator was connected, a luminous display at the end of the tube showed a slight glare. In the second experiment, a better vacuum was achieved by pumping, so that the stain could be observed on the screen. Braun approached the tube coil and connected the alternating current. The stain turned into a oscillating line. He watched the oscillation on a rotating mirror, indicating a two-dimensional image. Professor Braun rose, addressed his assistantship, and asked them to "meet personally" with the alternating current of the Strasbourg Generation Station (Figure 27-4).

The discovery was published on February 15, 1897, at the 25th anniversary of Braun's doctorate. Braun accelerated the electrons from a cold aluminium cathode by Töpler's influential machine with twenty plates. They passed the anode to fly through an aluminium aperture of 3 mm wide. Near the opening, Braun placed a small electromagnet with its axis perpendicular to the tube axis. When the current flowed through the electromagnet, the recording point moved around the screen. In addition to the sinusoidal record of the alternating current of the electric power station in Strasbourg, he also observed the Lissajous curves and the phase shift in polarization.

²⁹⁷⁶ Braun, 1897.

Additionally, he measured the rate of spread of the magnetic disturbance through the iron.²⁹⁷⁷

Braun followed the research of Bavarians down south. Graetz' neighbor in Munich Polytechnic, Beetz, used thin films to investigate magnetic phenomena. The son of the controversial famous Jewish historian Heinrich Graetz (1817 Książ Wielkopolski south east of Poznan-1891 Munich), the associate professor of Munich university Leo Graetz, confirmed Stefan's law in 1880. At the University of Munich Graetz discovered the rectifying (directional) effect of the aluminium electrode, covered with a thin layer of oxide, and showed the possibility of using it in cathode ray tube.²⁹⁷⁸ On April 25th, 1897 Graetz discovered that the aluminium cathode, covered with a thin layer of oxide, acts as a rectifier without moving parts, which converts alternating current into DC. Two months later Karol Franciszek Pollak (November 15, 1859 Sanok in southeastern then Habsburg Poland-1928 Bielsko-Biala in southern Poland) announced that he had already used the same phenomenon at his battery factory in Frankfurt on Main.²⁹⁷⁹

On 14 April 1898 Braun continued Pollak's and Graetz's research by measuring the emitted light of the aluminium electrode in the electrolyte. On March 29, 1898, Braun supplemented his cathode ray tube with an additional iron rod in the glass tube on the screen. He compared the cathode rays with a "conductor" attached to the cathode. With the magnet he curved the other end of his "conductor" while considering the high velocity of electrons and their frictional interactions with gas particles in the cathode ray tube.²⁹⁸⁰ Geissler's toy used as low-pressure glow discharge tube was finally transformed in highly commercially successful Braun's cathode ray tube for radar and television displays of a next century. Forty years passed in between to enable the growth of a funny toy into the great industrialized instruments in the hands of the new generation of researchers. Another decade passed from Braun's cathode ray tube to Forest's amplification vacuum tube (valve, electronic tube) as the first electronic amplifier which dominated electronic for a half of century.

²⁹⁷⁷ Braun, 1897, 552-553.

²⁹⁷⁸ Graetz, 1902, 1100-1110.

²⁹⁷⁹ Graetz, 1897, 326-327.

²⁹⁸⁰ Braun, 1898, 368, 370-371.

Braun's discovery did not pass without conflicted struggles for priority. Albert Hess, the head of the electrochemical department of former Edison's collaborator Johann Sigmund Schuckert (1846 Nuremberg-1895 Wiesbaden) of Nuremberg, claimed in *Annalen der Physik* in 1898 that he himself described and the president of Parisian academy Marie Alfred Cornu (1841-1902) demonstrated a similar cathode-ray tube in French, American and other journals already in 1894. In 1898, Hess announced the construction of his popular form of cathode-ray tube.

Braun and colleagues gave lectures about the new device in weeks after discovery. Braun's assistant Zenneck embarrassed the engineers at a generator station in Strasbourg when he showed during the lecture that the frequency of their alternating current ranged from 48 to 52 Hz. They felt that they claimed that their customers should be satisfied because they even supplied them with a current above the commanded frequency of 50 Hz at no extra cost. Between July and October 1897, Braun introduced his invention to Toronto at a meeting of the British Society for the Advancement of Science. The demonstration experiment was not particularly successful, but Braun brought his cathode ray tube to America, where it penetrated virtually every house in the next century. Braun visited his successor, Hertz, in Karlsruhe, but initially he was not interested in Hertz's new electromagnetic waves and a photoelectron.

In the following months, Braun changed his mind about Hertz's discoveries, but only after returning from America he began to work on radiotelegraphy on the initiative of a group of entrepreneurs from Strasbourg. Together they founded Telebraun, which merged with Siemens and Halske in December 1900. For many years, Braun's company has been in dispute with Slaby's and Arco's Berlin-based AEG company until, on the orders of the Emperor, on 27 May 1903, they merged into Telefunken. Thus, they were able to compete with Marconian British company, as they had a monopoly on German radio. Arco, in contrast to Slaby, became a great Braun's (and Codelli's) friend. Braun even arranged Arco's honorary doctorate at the University of Strasbourg. For success in the development of the radio, Braun

shared the Nobel Prize in Physics with Marconi in 1909.²⁹⁸¹

Braun was primarily an experimental physicist and regretted his lack of mathematical knowledge in a joke.²⁹⁸² The students and friends liked ridiculing Braun's calculation inaccuracies. Braun's student and later co-worker Zenneck described how Professor Braun during the lecture rounded his result of the " 2×25 " multiplication to " 2×30 " and wrote 60 as a product, adding, "because previously we used 2×30 instead of 2×25 , the real score will be close to 50." As a professor in Strasbourg, Braun accepted Alsace for his homeland and in February 1905 even rejected the most distinguished chair in Berlin offered by the Minister of Education after his lecture in honor of the Emperor's Birthday. The nationalism was foreign to him, and he was among the rare German professors who refused to sign under the chauvinist "Manifest 93" with Roentgen, Nerst, Wilhelm Wien, Planck, Ostwald upon the beginning of the First World War on October 4, 1914. Nevertheless, on December 17, 1914, Braun decided together with Zenneck to make a secret journey with a Norwegian ship to New York, where he was supposed to defend his company's interests against Marconi's demands. Returning to Europe was not successful because of the English blockade. Thus, he remained in the United States in the care of his son, Conrad, who had been working in New York Bank since 1912. After the United States entered the war, Zenneck was interned as an enemy spy; Braun did not have such huge problems but even he had no chance of scientific research as he was not allowed to leave Brooklyn. On 20 June 1917, Braun received the honorary doctoral title of the Technical University of Vienna, the only one of that kind during his famous life. A few months before the end of the war, he died in New York. He highly assessed the possibilities of the cathode ray tube for scientific research, although initially it was slow due to the low mobility of its ions.²⁹⁸³

27.6.2 Zenneck

Braun's assistant Zenneck improved the cathode ray tube by using an additional aperture in the neck for better focusing. He designed a method of deflection in the horizontal direction, so that it was

²⁹⁸¹ Hess, 1898, 622; Siemens, 1957, 1: 204–205, 185.

²⁹⁸² Jungnickel, McCormach, 1986, 2: 346.

²⁹⁸³ Braun, 1897, 553.

no longer necessary to observe the fluctuation of the current on the rotating mirror. On September 26, 1899, CaDO_4 cathodoluminescence was more easily photographed than green CaS , especially in low discharges, when the luminescent point travels quickly across the screen. CaWO_4 was recommended for use in X-ray photography, and in 1925 Zworykin patented it as a blue luminophore for color television. In 1904, Zenneck photographed the oscillograph of the dampening oscillation with the help of Braun's cathode ray tube used as oscilloscope.

Zenneck was the son of a minister from Swabia. At first, he intended to become a high school teacher of mathematics and science. After a Ph.D. in zoology, he had already studied in London and only came to Braun's laboratory in Tübingen as twenty-five years old expert. Braun offered him an assistant post in Strasbourg, but Zenneck nearly "escaped" two weeks later as an assistant to a zoology teacher in Tübingen. At that time, there were few students of natural sciences, but most of them preferred to teach secondary school pupils with a better salary than to wait for a free chair at their unpaid assistant posts.

In the school year 1901/1902, Zenneck was the first to lecture at the German university on electromagnetic fluctuations. In the summer of 1905, Zenneck became an associate professor at Danzig (now Gdansk), and shortly thereafter Braun arranged his regular full professorship at the Technical University of Braunschweig. In 1913 he moved to the Technical University of Munich. In 1933, he became the head of curators of the German Museum's administration in Munich, where he placed copies of Braun's original devices which were nearly lost in the US and the original Magdeburg hemispheres later examined there by the DVTS president Janez Kovač.

27.6.3 *Other German Researchers: Wehnelt and Rogowski*

The German Arthur Wehnelt was born in Brazil where his father worked as shipbuilding engineer, co-founder and co-owner of the Brazilian Lloyd. They returned to Hamburg while Arthur Wehnelt was still a baby, but the early Brazilian racial mixture still influenced his electrodynamic concepts. In Charlottenburg by Berlin, Arthur Wehnelt first studied engineering, then physics. In

1898, he received his doctorate in Erlangen in Bavaria. In 1903, as an associate professor there, he accidentally discovered more radiation from parts of the cathode damaged by the ointment used to seal the valves of cathode ray tubes. He assumed that the dirty areas contained metal oxides, so he was looking for the best among them. He chose barium oxide, which we use today. He got the electron beam already at the acceleration voltage of a few hundred volts in a cathode ray tube with a very thin glowing cathode of platinum, covered with a few millimeters wide metal oxide stain. He did not use the voltage above 1000 V, as it caused a strong sputtering of platinum. The slow electrons were easily controlled by electric or magnetic fields. The electrons heavily ionized gas, therefore the best possible vacuum was desired. Wehnelt's current of electrons was continuous, and their velocity was subject to change within wide limits.²⁹⁸⁴

In 1903, Wehnelt and König placed diffraction electrostatic panels in Braun's cathode ray tube, which they demonstrated at a gathering of German naturalists and doctors in Cologne in 1908. In the years 1904 and 1905, Wehnelt used a cylinder with a slit that he placed around the cathode to control the electron flow. In 1908, he became a full professor, and in 1926 he became director of the Physical Institute in Berlin. Wehnelt's cylinder was first used for X-rays, and the son of Triestino trader Victor Josef Karl Engelhardt (* 1866 Vienna; † 1944 Berlin) after his studies in Higher real school of Trieste and Polytechnic of Vienna rearranged it for Braun's cathode ray tube for his paper published in *Physikalische Zeitschrift* in 1923.

The professor at Technical College of Aachen, Walter Rogowski, was a leading expert for Braun's cathode ray tube for a long time, especially when they started to use Wehnelt's oxide cathode. In 1925 in Aachen, Rogowski developed an oscilloscope with a phosphorescent layer of ZnS . He accelerated the electrons with 25000 V from a glowing cathode in a rectangular direction towards anode. Between the anode and the fluorescent display, he set a narrow aperture. In the older C. Samson's model, the aperture was too close to the cathode. Therefore, the 5 mm diameter record on the screen was too dark and unusable for high

²⁹⁸⁴ Wehnelt, 1905, 732–733.

frequencies.²⁹⁸⁵ On the Rogowski screen, the beam plotted a curve that could be observed, measured or photographed. The first useful model was made for AEG, while an electron microscope was additionally built up during the development.²⁹⁸⁶

27.6.4 *The "Mechanical" Television Development Period*

Dieckmann, Rosing and Campbell-Swinton's use of the cathode-ray tube did not immediately affect the development of television at the beginning of the 20th century. The speed of reflection, the sharpness of the record, the lifetime of the device and the quality of the scanning beam focus were too low before Busch's electron optics was used. Therefore, Braun did not support the use of his tube in television that was for him something like telepathy. As the businessman-inventor Braun was clearly far from any kind of Victorian spiritism which even deteriorated his early acquaintance with Tesla in Kundt's lab in Strasbourg.

27.6.5 *Television among Russians*

Rosing was a descendant of Dutch apothecary whom Peter the Great invited to Petersburg general land hospital; and sent as courtier to Kyakhta near the Mongolian border south of the lake Bajkal. Rosing has built up more than hundred and twenty different television schemes and systems in total. In 1907, he set up an electronic television system with a Braun's cathode ray tube on the receiving side patented at home, in the United States, Germany, and England. At the University of Petersburg, he modulated the jet of electrons with a photocell signal and deflected it with magnets. His recording device was still mechanical. To scan the downloaded image, he used two mutually perpendicular mirror drums that he spun around the common axis. The slow selenium photoinduction cells were replaced by faster photocells from alkali metals but Rosing was still unable to amplify the weak flows of the order of 0.1 pA.

He exhibited his system in St. Petersburg in 1910²⁹⁸⁷ and showed the receiving of simple

geometric shapes in the following year. He continued his television research until 1931, when he was sentenced to three years in the Kotlas Archangelsk, during the Stalinist purges; there was a cold death waiting for the poor inventor (Figure 27-5).²⁹⁸⁸



Figure 27-5: Photo of Boris L'vovich Rosing (* 1869; † 1933)²⁹⁸⁹

In Leningrad (today St. Petersburg), Grabovski, the engineer later professor of electrotechnics in Saratov university Viktor Ivanovič Popov (Виктор Иванович Попов, 1895-1965) and Saratov exact science teacher Nikolai G. Piskunov (Николай Георгиевич Пискунов, 1886-1941?) filed a patent for "radiotelephot (radiotelefot, радиотелефот)", the first practical, purely electronic television. Among them only the comparatively wealthy Piskunov had previously visited other European countries and mastered several foreign languages to get more information about the progress of electronics in the west. They started experiments in the laboratory of industrial technics in Saratov in July 1925. In their system, under the influence of light the photocathode emitted electrons that were rejected by a grid in its vicinity.

²⁹⁸⁵ Busch, 1927, 583, 591.

²⁹⁸⁶ Siemens, 1957, 2: 192–193.

²⁹⁸⁷ Kleinert, 1993, 71; Zworykin, Ramberg, Flory, 1958, 12,

²⁹⁸⁸ Fisher, 1996, 263.

²⁹⁸⁹ Fisher, 1996, 236.

The electrons as "rays" from thermo-cathode passed through the grid and collided with photocathode. There they collided with oppositely oriented photoelectrons, which more weakened the thermo-cathode rays as more of them gathered at a given point in the photocathode.

Thus, an electronic beam was modulated, which then transmitted information about the illumination of the object. In the next three months, they experimented at the Leningrad Vacuum Institute. They spent only 1,500 Rubles, despite relatively complicated experiments. Unfortunately, the commission in Leningrad initially did not support the use of their device.

The son of the exiled Ukrainian revolutionary poet Pavlo Hrabovsky, Boris Grabovski, returned to Tashkent through Saratov and continued his research with Rosing's help while Popov and Piskunov resumed their lecturing in Saratov on Volga river southeast of Moscow. On 28 July 1928, the commission acknowledged the usefulness of the "telephoto" patented by Grabovski and his laboratory assistant military officer Ivan F. Beljanski (Иван Филиппович Белянский, 1907-1979). They downloaded seven pictures per second to a screen placed 6-7 m away in another room. The screen had a diameter 5-6 cm with 200 to 300 lines. They changed their original idea by applying the photosensitive layer onto the impermeable silver base. The image projection and electronic rays were now on the same side of the photosensitive layer, like in later iconoscope of Rosnig's student helper Zworykin in USA in 1923 and in 1933.²⁹⁹⁰ As White army official wealthy Parisian student Zworykin certainly did not collaborate with Red Army officers like Beljanski.

27.6.6 Television in the UK

The Edinburgh born engineer Campbell Swinton was director of industrial companies in London, where he was mainly concerned with the installation of electric lighting (Figure 27-6). After Röntgen's discovery, with the mediation of Lord Kelvin, Campbell Swinton published research of the cathode ray tube with the RS between 1896 and 1899. On 27 February 1897, he confirmed that X-rays originated from the area of green luminescence of the cathode ray tube and

investigated the cathodoluminescence of charcoal. Two years later, he measured the cathodoluminescence of rare earths, while he described the cathode coloring with a radioactive radium that reduced the current required for the discharge of Wehnelt's cathode ray tube on 22 June 1906.



Figure 27-6: Photo of Campbell Swinton (* 1863; † 1930)²⁹⁹¹

Campbell Swinton did not yet know about the photoelectric effect phenomenon suitable for the transmitter of such a high speed and amplification. In 1908 he responded to a discussion in *Nature* about the French television system of President of the French Society of Aerial Navigation graduate of the Ecole Polytechnique Jules Alexis Marie Armengaud (1842-1921) and Cambridge graduate Shelford Bidwell FRS (1848-1909 Weybridge in greater London) with a proposal to use the cathode ray tube. On November 7, 1911, for the Röntgen Society in England, whose chairman he was, Campbell Swinton described the screen of a transmitter from small cubes of ruthenium as a stand-alone photocell in a emptied vessel with a photochemical sodium steam.²⁹⁹² Until 1926, in his

²⁹⁹¹ Fisher, 1996, 236.

²⁹⁹² Schröter, 1932, 61; 246-248; Swift, 1950, 82-83; Dussaud, Armengaud, 1898; Dussaud, *Le microphonographe* 1897; Cinemacrophonograph or Phonorama of Berthon, Swiss natives François Dussaud, and George Jaubert.

²⁹⁹⁰ Barancev, Urvalov, 1986, 135.

own laboratory in London, Campbell Swinton successfully tested such mosaic photo-elements.

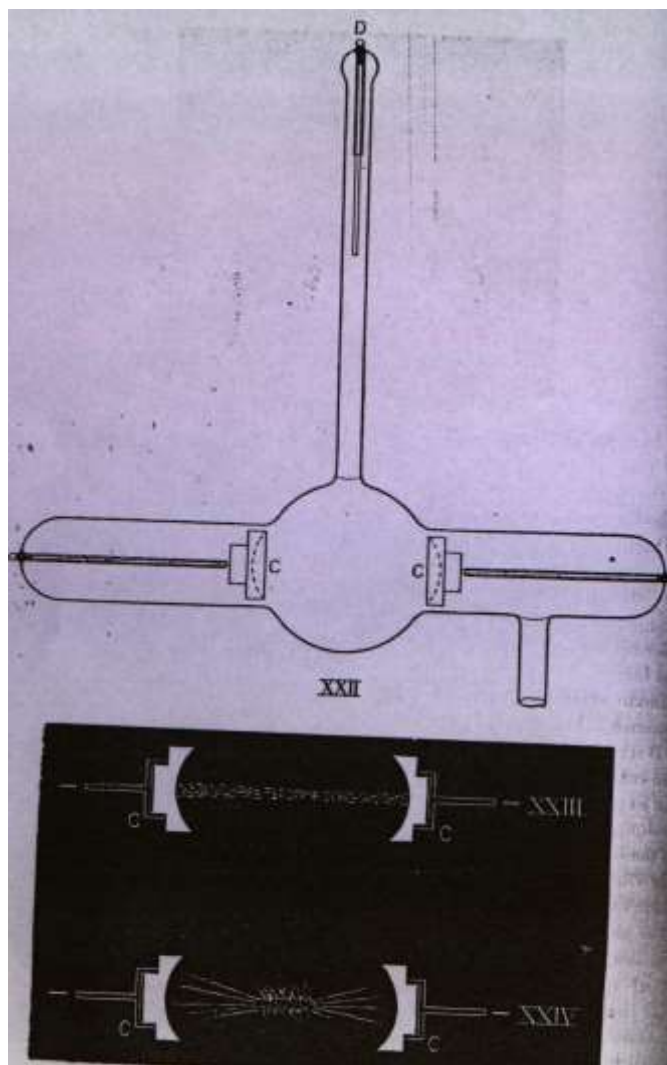

Figure 27-7: Swinton's cathode-ray tube with concave charcoal cathodes (Swinton, Alan Archibald. March 1, 1897. *Some Experiments with Cathode Rays*, Proc.Roy.Soc.London. 61: 94)

In September 1921, at a BAAS lecture, the visionary Campbell Swinton described the reception of radio signals from the Eiffel Tower in his London laboratory. On 6 December 1913 Braun published the results of similar measurements in Strasbourg. On 26 March 1924, Campbell-Swinton reported to the RS about the possibilities of wired and wireless television. Instead of a plurality of conductors that transmit individual elements of the mosaic of illuminated images, modeled on light-sensitive nerves in the eye, he designed only three wires and the grounding. His transmitter and receiver were Crookes' cathode ray tubes with perforated anode.

At a voltage of 100 kV, the fluorescent screen should illuminate every tenth of a second to suit the human vision.

Campbell-Swinton's television has never worked. His ideas were established only in the next decade, since big companies were not interested in them at first. Other researchers in the various countries have developed six other models of picture-making cathode ray tube models for television until November 1925.²⁹⁹³

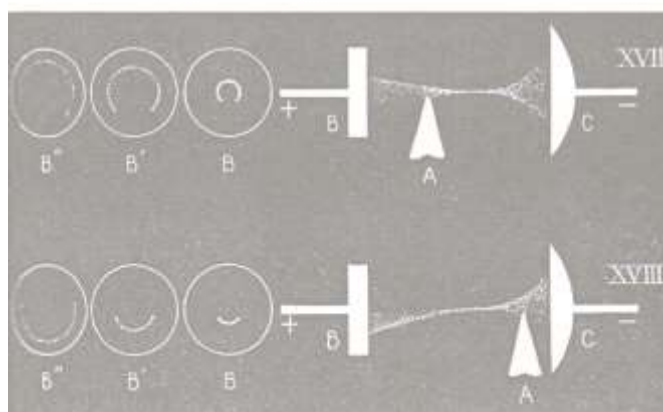
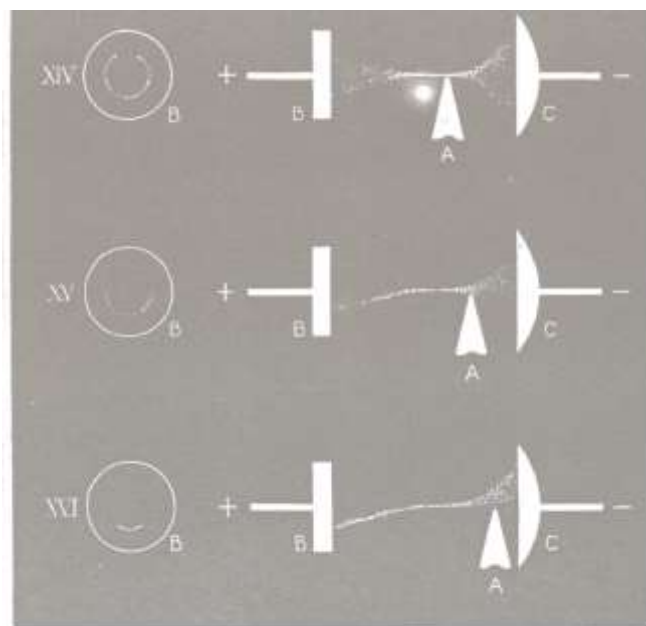

Figure 27-8: Swinton's experiments on the luminescence screen of a cathode electron tube (Swinton, Alan Archibald Campbell. March 1, 1897. *Some Experiments with Cathode Rays*, Proc.Roy.Soc.London. 61: 89)

The Scotsman Baird founded the first company dedicated exclusive to television named Television Limited. Until the decision of the British

²⁹⁹³ Barancev, Urvalov, 1986, 131.

Commission on 13 February 1937 he successfully competed with the electronic television of Marconi's company EMI. Despite of the small material support received, he publicly demonstrated his television using Nipkow plate of frequency 8.3 Hz and colloidal self-manufactured cells for scanning the reflected light in April 1925. The sensor had to be thousands times more sensitive than older appliances, which broadcasted only the shadows of transmitted light. The letter "H" was clearly visible on the receiver, but it was harder to transmit picture of a hand or face on which it was possible to notice the movement of the mouth.²⁹⁹⁴

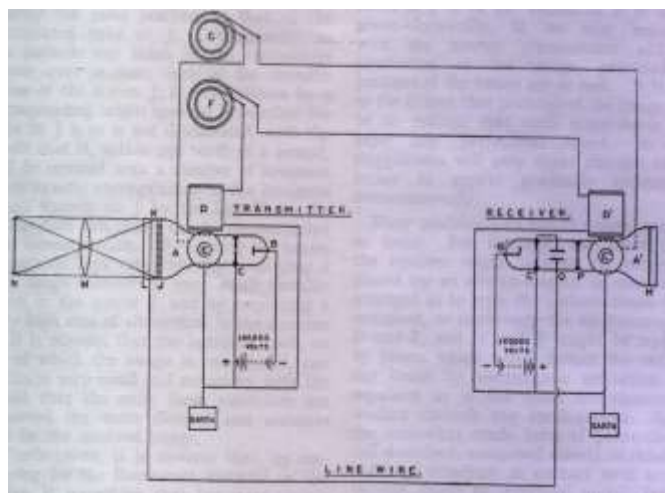

Figure 27-9: Swinton's television system with cathode ray tube designed in 1911 (Swinton, Alan Archibald Campbell April 9, 1924. *The Possibilities of Television, Wireless Word and Radio Review*. 54)

Within a few months, Baird managed to solve the problem of wire transfer and even the wireless, which he showed to the forty members of the RI on 27 January 1926. Campbell Swinton looked at Baird's invention and reported in his London club about his "conversion". However, in July 1928, he changed his mind and criticized Baird's work in sharp letter sent to the Times as he preferred electronics to any other designs.

In 1927, Baird received a British patent for stereoscopic wired or wireless transmission of images or motion. Around the rotating Nipkow's disc he put one or two spiral lenses and photocells on each other so that each one covered only one area of the image or only one color. The light was filtered, and then he projected the colors into one

²⁹⁹⁴ Baird, 1925, 535.

in the receiver. The operation of his device was demonstrated in London on June 3, 1928.²⁹⁹⁵

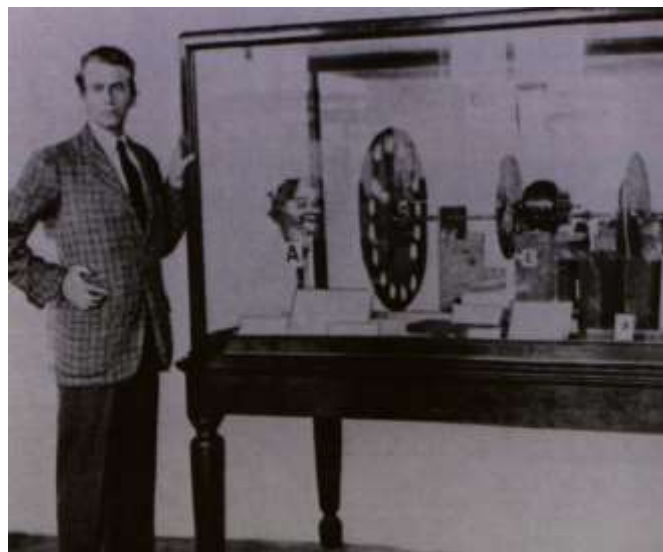

Figure 27-10: A photograph of Baird in front of his favorite television system (Fisher, 1996, 236-237)

On February 8, 1928, Baird sent his first wireless image across the Atlantic with 45 m waves without intermediate transducers. On 18 July 1929, at Telefunken in Berlin Carl Schapira (1879 Gdansk-1957 New York) received two television models of Baird and his director, Captain Oliver George Hutchinson (1891 Belfast-1944). The devices cost 90 or 12 marks; they downloaded 12.5 images with 30 lines per second at 9000 Hz. Baird was sending images over the telephone cable inside the house and recognizing the seated person with no details. Schapira felt that the Telefunken's device with forty-eight mirrors better transmitted the moving images, just like Guericke thought that he was better than Boyle and vice versa almost three centuries earlier. In 1933 Nazis outed the Jew Shapira who fled to Madrid and New York where he became US citizen under the assumed name Carlos Soria as a notable art collector.

Baird replaced Nipkow disc by a drum with thirty mirrors, which the BBC used in its first public television show of horse races from Derby on June 1931 and on 29 April 1932. On 2 August 1932, the BBC began broadcasting a television program for eight months, and on November 2, 1936 the first regular television shows appeared in London.²⁹⁹⁶

²⁹⁹⁵ Fisher, 1996, 60, 79, 301.

²⁹⁹⁶ Swift, 1950, 54, 57, 84.

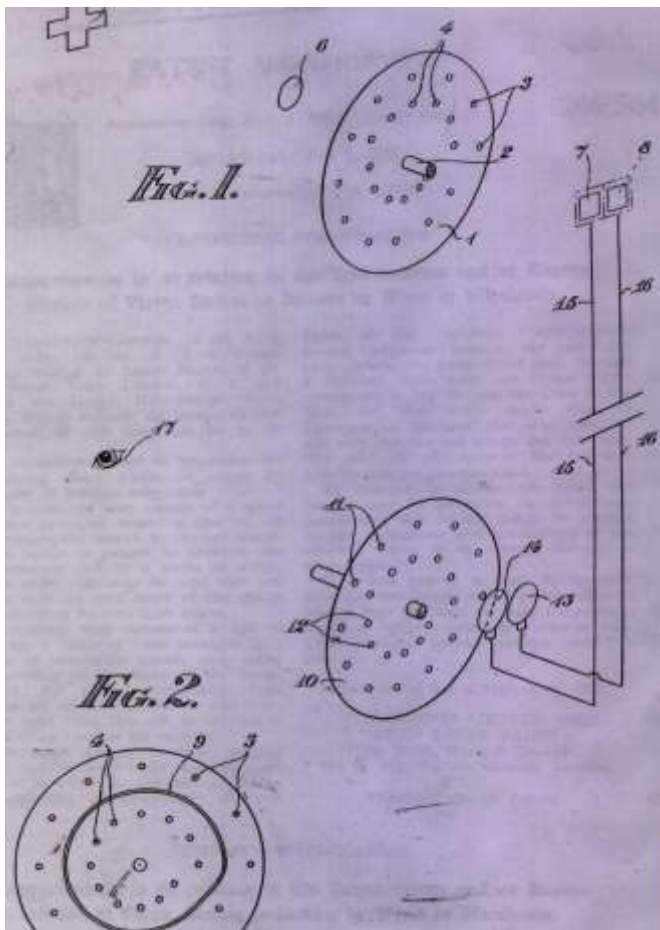

Figure 27-11: Improvements to Baird's television system which Codelli obtained through his lawyer Abrahamsohn and fed in his domestic Ljubljana archive (Baird, 1927, 6)

27.6.7 Television in Germany

Braun's assistants Dieckmann and Glage patented Braun's cathode ray tube for transferring letters and drawings without moving parts in the receiver in Strasbourg on September 12, 1906. They scanned images of metal models by twenty contact brushes, which replaced the apertures in the Nipkow-disc. The brushes were connected to a sawtooth voltage generator in the horizontal deflection coils of the cathode ray tube and with the contact brushes on the moving wires of the potentiometer that emitted current to the coils for the vertical deflection.

By contact with the conductive point on the metal model, the brushes of Nipkow plate produced a current through the electromagnet. They used the electromagnet to deviate a jet of electrons in the oscilloscope. So, the jet missed the opening on its way. Conductive parts of the model were therefore darkly reflected on the bright base of the

oscilloscope screen. The entire turn of the Nipkow's disc lasted 0.1 s, so the light-emitter on the screen could follow the movement and rotation of the model. The screen could be photographed, which they emphasized twice in their patent file as the important and modern idea. Although Dieckmann's apparatus was more like a fax than a television, with its receiver it improved electronic recording of the image (Figure 27-12).²⁹⁹⁷

Patent did not delight their teacher, as you might expect. Braun was angry because his invention was used for such purposes. According to Dieckmann's record forty-two years later, "looking at the distance was not at all a respectable field of research at that time - it was something like it was once *perpetuum mobile*". Braun died prematurely before he could change his mind.



Figure 27-12: Photograph of Max Dieckmann (* 1882; † 1960)²⁹⁹⁸

Dieckmann finished the Grammar School St. Thomas in Leipzig where Braun once taught. In 1906 he became Braun's assistant in Strasbourg, and in the following year he defended his dissertation. In March 1914, as a private assistant in Munich, he collaborated with Braun and Count Zeppelin with his experiments in radiotelegraphy and aeronautics. He devoted to those problems all his career. During the First World War, he investigated the possibilities for a television connection between the crew of plane and their assistance on the ground. In 1925, at the exhibition of traffic and transport in Munich, he showed his

²⁹⁹⁷ Dieckmann, Glage, 1906; Zworykin, Ramberg, Flory, 1958, 7–9; Kleinert, 1993, 71.

²⁹⁹⁸ Fisher, 1996, 236.

television system with a cathode-ray tube. The device might not work, as his patent application failed. With the help of his assistant Rudolf Hell (1901-2002 Kiel) he described a similar recording tube, which Farnsworth patented in the US a year later.²⁹⁹⁹ During the war years, Dieckmann was the director of the German Research Institute for Telecommunications near Munich.

Gustav Glage was the son of a lower railway official and he defended his PhD in Braun's class in Strasburg. In 1908 he became Braun's assistant. He received his doctorate by researching the resonant inductor with the support of Telefunken, and then became a gymnasium professor.

At the Physical Institute of the College of Dresden in May 1925, Dember discovered an increase in emission by simultaneously exciting photolayers with electrons and photons. For his investigation of the dependence of the additional photocurrents on aluminium from the intensity of light at a constant flow of cathode rays, he used a diffusion pump from the Kaiser Wilhelm Institute in Berlin. The photoelectric effects increased due to cathode rays, and the long-wavelength threshold (red) of photoelectron emission shifted towards longer waves.

Dember's experiments confirmed Lenard's theory, according to which the average energy of incident cathode rays is smaller than the work function (the electron binding energy) of the material and is therefore not enough for the emission of electrons from the substrate. So, the electrons remain in the metal in their excited state and the light of lesser energy can then eject them from their metal.³⁰⁰⁰

In 1931, Dember found that the illumination of copper oxides with strongly absorbing light produces a difference in potentials in the direction of the propagation of rays. The following year, such a phenomenon was observed in diamond and ZnS, and later in other semiconductors. In 1935, Frenkel showed that such a potential difference occurred in unevenly illuminated cases due to differences in coefficients of diffusion of electrons and holes. The faster charge carriers overtake the slower ones, and between the illuminated surface and the inside there is a difference in potential. If

²⁹⁹⁹ Fisher, 1966, 119, 147.

³⁰⁰⁰ Dember, 1925, 529-530; Barancev, Urvalov, 1986, 131-136.

the speeds of the electrons and holes are the same and they have equal lifetimes (relaxation times), then the effect of Dember disappears. In practice, it is covered by much larger changes in the contact difference of potentials caused by unbalanced carriers near the electrodes.

In the summer of 1919, Mihály publicly demonstrated his television system "telehor" in Budapest. He was born in Gödöllő near Budapest in the family of a doctor. After a real gymnasium, he studied at the Technical College of Budapest. He became acquainted with the problems of television during the war when he worked at Telefonfabrik in Budapest. In 1923, he published the first book, entirely dedicated to television. The following year he went to Berlin and from 1927 he developed television for German State Post while Edouard Bélin researched in Paris for the Austrian state radio company RAVAG.



Figure 27-13: Photo of Dénes von Mihály (* 1894; † 1953)³⁰⁰¹

The co-worker and assistant of the Physics Institute in Leipzig, Karolus, improved the photocell. He used the effect of Scotsman Kerr to modulate light in a television set. On June 21, 1924, he received a German patent for scanning with two Nipkow plates with 48 holes. Behind them he put Elster-Geitel's alkaline photocell.³⁰⁰²

On 11 May 1928, in addition to Telefunken Television, produced by Karolus and Schröter, Mihály's 30-channel television was also presented at the Berlin Radio Show. In one second, it

³⁰⁰¹ Fisher, 1996, 236.

³⁰⁰² Siemens, 1957, 100.

changed 10 images sized 4 cm × 4 cm. Mihály used a tungsten filament arc light and a 30-hole Nipkow plate made of pertinax hard paper (Figure 27-13). In March 1929, state post office in Berlin had a television picture with 900 points, but soundless.

The Allgemeiner Deutscher Fernsehverein was founded on September 13, 1929 and began to issue Fernsehen magazine in August of the following year in Berlin. Apart from Codelli and Mihály, most of the other authors of the new magazine defended the advantages of electronic television with the cathode-ray tube because of its more promising synchronization and in number of points in the picture. Most of the discussions in Fernsehen were published by von Ardenne, who, in his own laboratory in Berlin developed a cathode-ray tube in the form of a modern electronic rifle parallel to Zworykin in the late 1920s. Ardenne advocated the use of ultra-short waves in television. In 1931 he described the indirect warming of the cathode to prevent the scattering or sputtering of cathode material in the cathode-ray tube which could cover the vital parts of the tool. At the Berlin Radio Show together with the Jew Siegmund Loewe (1885-1962), Ardenne first publicly demonstrated purely electronic television. His system overshadowed the designs of Mihály and Baird (Figure 27-14).³⁰⁰³



Figure 27-14: Photo of John L. Baird (left) (* 1888; † 1946) visiting von Ardenne's laboratory³⁰⁰⁴

Von Ardenne used Zworykin's suggestion issued on 29/12/1923 about the cathode ray tubes as a

scroll engine with a moving point of the record. He depicted on the cathode-ray tube the scanned model of uniform intensity, whose image he wanted to transfer. The leaked or reflected light was collected by a photocell. The effect was proportional to the permeability or repulsiveness of the scanned point and generated a signal for the image. If the light was emitting longer than the transition time of each element of the image, the scanned point was stretched to the line, and accordingly lowered the horizontal resolution. The original scanners with a mobile data point in the cathode-ray tube were not practically usable until effective photomultipliers with low inertia and high sensitivity began to use.³⁰⁰⁵

The basic problem of television with a cathode-ray tube was the sharpness and brightness of the point of the record, and the simultaneous control of the light and the distribution of points in the cathode ray tubes. Von Ardenne used Wehnelt's low-voltage cathode ray tubes according to Schröter's "half-image" method.³⁰⁰⁶

Manfred von Ardenne was born in Hamburg in the family of an army officer. In 1925 and 1926, he studied physics, chemistry and mathematics at the University of Berlin. He was wealthy enough to be able to organize work in his own laboratory, which received orders from the big industry and from Hitler's postal minister. In addition to income from numerous inventions, especially related to the cathode ray tubes, he also had a contract with Siemens & Halske. In 1936, he prepared a television broadcast of the Berlin Olympic Games, and on December 25, 1937, he published an explanation of the operation of a linear electronic microscope. A year later he used a jet of electrons as a working tool. In the years 1939 and 1940, he dealt with the electromagnetic separation of the ²³⁵U needed for Heisenberg's atomic bomb. After the war, he spent a decade in the Soviet Union, where he was no less successful than under the Nazi government. In 1955, he returned to the post of director of the Dresden Scientific Research Institute.³⁰⁰⁷

³⁰⁰³ Ardenne, 1931, 69; Fisher, 1996, 202.

³⁰⁰⁴ Fisher, 1996, 236.

³⁰⁰⁵ Zworykin, Ramberg, 1958, 18–19.

³⁰⁰⁶ Ardenne, 1931, 65, 66.

³⁰⁰⁷ Gloede, 1986, 178, 196, 199.

Among von Ardenne's associates at the Heinrich-Hertz-Institut für Schwingungsforschung in Berlin was Vladimir Šlebinger from Ljubljana, a son of the literary historian the academician Janko, and the brother of geologist Ciril. After graduating in Ljubljana in 1925, he studied electrical engineering in Prague and graduated in 1929. With the recommendation of the University of Prague, he received a research assignment for the training for the use of cathode ray tubes for television at the Hertz Institute. Between 1930 and 1933, he studied there with the founders of the Institute and its director between 1927 and 1936, Wagner, and his co-worker, prof. dr. Gustav Engelbert Leithäuser. On June 30, 1933, Leithäuser projected the adopted 90-line mechanical scanned image of the dimensions 18 cm × 21.5 cm in the lecture room of the Institute.

The image only took 30 and later 90 lines instead of today's 625. The Cathode ray tube was arranged at the Hertz Institute for light modulation and the reception, which took place in Berlin in 1930 during the World Energy Conference. In 1932, Šlebinger received a patent for the synchronization of the image in the receiver and for the light modulation of the cathode ray. The following year, he withdrew from Germany in fear of Nazism to join his parents in Ljubljana. He was without any full-time employment for four years and, therefore, he assisted the Trieste native Osana at the Department of Electrical Engineering at the Technical Faculty in Ljubljana until 1935. After 1928, Osana was involved in television technology and used Nipkow disc for his first experiments on the basics of television. Šlebinger went for some time to Belgrade as technical director of Philips, who planned to build a radio equipment factory there. In the meantime, in 1939 he promoted in Prague with the thesis "Exploitation of the waterpower and the Danube waterway in Djerdap". After years of work at the hydroelectric power plants in Yugoslavia, he left as a UN expert in Abidjan in 1968. After returning, he taught at the Faculty of Electrical Engineering in Ljubljana, as he always wanted.³⁰⁰⁸

On March 22, 1935, a television program was broadcasted in Berlin while changing 25 images with 180 rows per second. On 19 August 1935, the UKV television system was burnt on the third day

of the 12th radio show in Berlin, which was then repaired within 30 hours. The broadcasting from the day of the Nazi party in Nuremberg in 1936 could not be carried out because there was not yet an adequate cable. In the same year, the summer Olympic Games from Berlin were broadcast with Telefunken's iconoscope and Farnsworth's camera. On August 11, 1939, a boxing event was broadcasted and on 26 November 1939, a football game between Italy and Germany.

27.6.8 *Mechanical Television in the US*

Jenkins began to research television in 1894. Only a few months after Baird, on March 21, 1925, he developed a wireless mechanical television with a transmission of shadow contours over several kilometers. In 1926 he patented "remote cinema"³⁰⁰⁹ and two years later he started with his first television shows near Washington. Like the Carniolan Codelli, Jenkins also did not have enough financial support for a successful transition to an increasingly promising electronic TV.

At the same time, Herbert E. Ives of Bell Labs applied for a patent for television in natural colors with improved scanning. He used Nipkow-plate with photocells that covered the individual parts of the spectrum. Light fell on the rotating mirror through the holes in the panel. In the receiver, the current transmitted a record to the photocells connected to the individual parts of the plate plant by the conductor. The mechanism of rotation was such that the panel made a little more or little less turns than the commutator, thus achieving a change in the order of the links between the photocell and the modulator in the successive scan of the object.

Bell Labs offered the best mechanical television at that time.³⁰¹⁰ The development went to two directions: a "video phone", which would feature a visible image of the interlocutor and wireless television that would offer the picture with the sound of the radio. The advertising of products by radio and the press has become so profitable before the economic crisis of the 1930s to channel television into wireless development. The "video phone" featuring a visible image of the interlocutor was never profitable despite of good technology

³⁰⁰⁸ Notes of Maja Ilich, the granddaughter of V. Šlebinger's sister.

³⁰⁰⁹ Friedel, Israel, Finn, 1930, 17; Borchardt, 1930, 94–95; Swift, 1950, 34.

³⁰¹⁰ Dinsdale, 1931, 288; Fisher, 1996, 301.

backing because there were always a lot of people who wanted to talk without being seen.

27.6.9 *Electronic Television in USA*

Campbell-Swinton's ideas of purely electronic television flourished the most in the US. The USA researchers also faced the problem of moving the image to a long distance with a lower density of population than in Europe.

In 1921, the production of Braun's cathode ray tube in the United States was initiated by physicists Hendrik J. Van der Bijl of New York and Johnson from Gothenburg in Sweden, who has been studying at the University of North Dakota since 1910. In 1914 Johnson graduated and became an American. He received his doctorate in Yale in 1917. Between 1917 and 1925 he worked with Western Electric Co. and studied oscillographs with low-voltage cathode-ray tubes patented in the US. He then worked in Bell Telephone Laboratories, Inc., Mapelwood New Jersey, and finally at Laboratories Thomas Alva Edison Inc. In addition to cathode-ray electronics and noise, Johnson investigated the ionization of gases, the supersonic velocity in liquids and the secondary emission.

Bijl published his experimental research on the motion of slow electrons and ions in dense media before the First World War in leading German journals. At the end of the war, he studied the theory of thermionic cathode ray tube in the US and published a book in 1920.

The Electronic Television prevailed after Zworykin's success. At first, he worked for Westinghouse, where they were not enthusiastic about the modulation of electron beam intensities in television with an axially symmetric grid, reported by Zworykin on December 29, 1923; he therefore had obtained Patent No. 2141059 in the United States only on December 20, 1938. In 1925, as a Russian citizen in the service of Westinghouse, he supplemented the patent twice. The Cathode ray tube was reprocessed with a plate of 33 layers of different substances that replaced the fluorescent screen. On a plate made of aluminium or otherwise good conductor, he first put an insulator layer made of Al_2O_3 or MgO . A thin layer of photochemical potassium hydride was followed, which made it gray until it was thicker at higher thicknesses. He quickly dropped hydrogen

on it to give it a light blue color compound that had not yet turned purple.

Each pot of potassium hydride acted as a photocell. The mosaic screen for green, blue, and red was placed between the lenses.

From 1910 to 1912, **Vladimir Zworykin** studied at the Institute of Technology in Petrograd . In Rosing's laboratory, he realized the advantages of the electronic system compares to the mechanical. After graduating, he studied under supervision of the professor Langevin at the Collège de France in Paris. During the First World War, the theoretical physicist Langevin also dealt with radio-telegraphy and cathode-ray electronics. Rosing's Petersburg student and Paul Langevin Parisian student Zworykin did similar work in the Russian army and participated in the Petersburg branch of the Russian Marconi Company military electronic. At the end of the First World War, he went to the US as the emissary of White Army of Kolchak (Колчак).



Vladimir Zworykin (* 1888; † 1982)³⁰¹¹

On each sphere of potassium hydride, they were indeed a translation between spheres and the grid. The potassium hydride electrons did not come on the screen due to an intermediate insulator, so that the current ran only between the screen and the grid. They were modulated according to the generated current, amplified by triode and transmitted over the antenna.

³⁰¹¹ Fisher, 1996, 236.

Zworykin used an alternating current of 16 Hz frequency, and the images were changed twice faster, at 32 per second. The screens were made of compounds that were sensitive to different kind of colors, e.g. cesium chloride for red.³⁰¹²



Figure 27-15: Photo of David Sarnoff (* 1891; † 1971)³⁰¹³

On 18 November 1927 and in the following year, they made the first television shows in the United States.³⁰¹⁴ In November 1928, Westinghouse sent Zworykin to a visit to electrical laboratories in France, where the Bélin in Parisian Laboratory showed him the possibility of electrostatic focusing of electrons in a sufficiently good vacuum, which later replaced magnetic focusing. In 1928 or in early January 1929, Zworykin visited his two years younger Belarusian Jew Sarnoff at the Radio Corporation of America (RCA) in New York and described his idea of electronic television.

Sarnoff led the development of radio in the US and became president of the RCA on 3 January 1930 (Figure 27-15). From his conversation with Zworykin a Russian bond was born between the entrepreneur and the inventor, which enabled the dominance of electronic television in the coming years.³⁰¹⁵ Did they communicate in Russian or in English language?

On 16 November 1929, at a meeting of I. R. E. in Rochester, New York, Zworykin reported on a kinescope patented in the United States under no. 2109245 on February 22, 1938. RCA already had a functioning television system and the necessary financial resources available. However, the financial collapse in October 1929 delayed the marketing of already completed technology.

In 1930, Zworykin became the head of an electronic laboratory at RCA, which developed in 1919 from a branch of Marcon's company in the United States. Zworykin was served as the Honorary Vice-President of RCA in 1954. His early rival was Ernst Frederick Werner Alexanderson, born in 1878 in Uppsala. Alexanderson promoted his mechanical television. Zworykin challenged his ideas and displaced him at Sarnoff's networks while Sarnoff was leading the development at RCA.³⁰¹⁶ Certainly, the ex-Russians made a better deal among themselves than with their traditional Swedish rivals. On November 13, 1931, Zworykin developed an iconoscope and for it a US Pat. 2021907 on 26 November 1935. The first iconoscope was not capable of more than 240 lines, but it first found a practical use. The image was transferred to a mosaic of mutually insulated silver balls that fluoresced the added cesium. The balls were at the same time photocathodes and capacitor plates. The other side of the mica substrate was covered with a metal electrode, which was at the same time the second plate of the condenser.

Each element of the image had its photocell (condenser), so that the density of the mosaic was about 100,000 cm². Lighting of the photocell depended on the light of the corresponding element. The photocurrent has charged the capacitor. During the rotation of the electron beam, which was used by the iconoscope as a commutator, the capacitors discharged one after another through the resistor. The voltage drops at the resistance corresponded to the luminous intensity of the individual elements of the image. The signals were then amplified and modulated by a carrier wave. The idea was developed in 1931 by RCA with a cost of \$ 4 million and replaced with mechanical television after 1934.

³⁰¹² Zworykin, 1927, 1, 3, 5.

³⁰¹³ Fisher, 1996, 236.

³⁰¹⁴ Swift, 1950, 61.

³⁰¹⁵ Fisher, 1966, 114, 167, 174, 199, 360.

³⁰¹⁶ Fisher, 1996, 236.

Philo Taylor Farnsworth of the Mormon family in Utah spent his youth on the farm without contact with radio devices and only heard about electricity when he was fourteen years old. He finished high school in Ragby, Idaho, and then studied for two years at Brigham Young University in Provence, Utah.

In 1926, his ideas on electronic television were supported by Crocker Research Laboratories of San Francisco, which became Farnsworth Television and Radio Corporation in 1938. Apart from television, his ideas also influenced the development of radar and nuclear reactors. Later he drank too much and died forgotten by the world of science in Salt Lake City.



Philo Taylor Farnsworth (* 1906; † 1971)³⁰¹⁷

In the image analyzer, the transferred image was projected onto a photocathode. Zworykin deflected the stream of photoelectrons from the cathode with rectangular magnetic fields by passing electrons from the various openings in the sequence along the scanned line to generate an image signal.

Farnsworth improved Dieckmann's German patent analyzer in San Francisco. He added a longitudinal magnetic field to focus parallel to the axis, to achieve a sharp electronic image in the plane of the

aperture. His ideas were drawn from the popular papers of Russian Rosing, who therefore influenced the main USA rivals Farnsworth and Zworykin. In 1931, Farnsworth scanned 200,000 elements of the image of three people in the size of 4×2.75 inches with alternating sawtooth voltage with frequency of 12 Hz and 4800 Hz. His transmitter was Braun's cold-cathode ray tube in high vacuum and a small photocathode on silver-plated glass. Only a small part of the photocathode was not shaded from the gas discharge. The anode parallel to the photocathode were from a thin layer of tungsten or nickel. The protection was a thin layer of platinum on the inside of the tube. In the photocell plane was a fluorescent screen. The electrons were accelerated with a voltage of about 500 V and deflected with a transverse magnetic field.

By an alternating sawtooth voltage with frequency of 3000 Hz and 15 Hz, it scanned 200 lines with 15 frames per second. The receiver was "oscillite", like Zworykin's, with two mutually perpendicular coils. The anode tube was at the center of the electrons flew from the transmitter or the fiber. He gave a better picture than a mechanical television from Bell Labs. At the end of 1931, Farnsworth's television was sold at 50 pounds, and the adapter for an additional 20 pounds. The customers were able to look forward to TV shows of 1000 hours, while the cost of restoring a deteriorated receiver was 2-3 pounds.³⁰¹⁸

On 22 July 1935, Farnsworth was given priority in the invention of the television system after years of his conflict with RCA.³⁰¹⁹ Farnsworth's image analyzer has long competed with Zworykin's system until the patents were granted to Zworykin on December 20, 1938.

In the next thirty years nobody could not get rid of the effect of gas ionization due to the low vacuum in the cathode ray tube. Therefore, they used special "loops" for ions to prevent destructive dispersion with the oxide of the coated cathode due to the positive ions formed in the electron beam. Until the aluminium screen was added to the cathode ray tubes, the fastest negative ions repeatedly burned the center of the phosphor screen.

³⁰¹⁷ Fisher, 1996, 136.

³⁰¹⁸ Dinsdale, 1931, 286–288.

³⁰¹⁹ Fisher, 1966, 236.

The undesirable effect of the secondary emission was eliminated by the physicists Harley Ambrose Iams and Albert Rose at Zworykin's Laboratory at RCA in Princeton in 1939. They used a slow switching beam that falls everywhere perpendicular to the mosaic in the recording tube, called the orthicon. In January 1946, with the collaboration of Paul Kessler Weimer and Harold Bell Law, RCA developed another 100 to 1000 times more sensitive image orthicon. The super orthicon came into use in 1947, and the smaller vidicon was designed in 1950.³⁰²⁰

The oldest of those researchers named Iams was born in 1905 and graduated from Stanford in 1928. Between 1927 and 1929 he worked at Westinghouse, later from 1931 to 1933 at RCA. Between 1933 and 1942 he was a design engineer at Harrison, and then until 1947 he was in Princeton as Einstein's neighbor.

Rose was born in 1910 in New York. After three years of assisting at Cornell University, after a doctorate in 1935, he was employed by RCA. He stayed there until 1975 and during that time he published fifty patents related to the television. One-year younger Law from Iowa received his doctorate in 1941. Between 1939 and 1941 he was an assistant at the State University of Ohio, where received his Ph.D. Weimer was in Indiana in 1914. From 1936 to 1937, Weimer was an assistant in Kansas, and between 1939 and 1942 he returned to the Ohio State University, from where he moved to RCA in 1942, RCA therefore brought together most of the American researchers of television. Ross, Weimer and Law received the prize "Television Broadcasters" in 1946. Rose also received the Liebman's Prize while Law got the Zworykin Prize in 1955.

27.6.10 Color TV

In 1880 Maurice Leblanc published a study on the problem of a television with a prism that divided the seven colors among the amplifying selenium cells. It was a naïve performance that solved the problem solely on a quantitative level for the desired features of the television system.

A Russian inventor Alexander Appolonovich Polumordvinov of Kazan asked for the patenting of a color television system with rotating Nipkow plates and concentric cylinders with slits covered with red, green and blue filters; his Russian patent was granted in December 1899. However, he had not yet had the technology available to enable such a system to function. On 12 June 1902, the German Bronk patented a mirror drum, a selenium cell and a Geissler tube filter with color filters.

On 27 June 1929 in the Bell Labs Ives demonstrated a color television for the first time in the United States. The receiver for electronic color TV was patented by Austrian J. Nagler in 1935, and in 1936 his system was developed by Baird in a color television with 120 lines scanned with Nipkow-plates in red, green and blue colors.

On 12. 7. 1938 the German Werner Flechsig patented the idea of a "shadow mask", which in electronic color television allows impact of a jet of electrons at different angles, only the excitement of luminophore of one of the three available colors. In the same year, Hans Pressler discussed his television in natural colors and, together with von Ardenne, solved the issue of the required frequency bands.³⁰²¹

Peter Goldmark, born in 1906 in Hungary, designed a color television already while studying in Vienna. After a doctorate in physics in 1931, he tried in vain to do some experiments with Baird in London, and then moved to the United States in September 1933. He published his color television system in the British Journal, and he was employed by Columbia Broadcasting Company (CBS) in New York on the New Year day in 1936. He invented a mechanical rotary filter, while otherwise he used Farnsworth's television system. On August 28, 1940 and on September 4, 1940, Goldmark demonstrated the operation of color television. On 25 June 1951, CBS began broadcasting a color TV program, which, however, had little audience because of the opposition of Sarnoff at RCA.³⁰²²

In September 1949, RCA organized several groups for researching the color image electronics, comparable to the black and white version of

³⁰²⁰ Zworykin, Ramberg, Flory, 1958, 18–19; Ustinov, Borisov, 1989, 121–123.

³⁰²¹ Leblanc, 1880, 477; Fisher, 1996, 299–301; Goebel, 1974, 853–856.

³⁰²² Fisher, 1996, 302–304, 320.

television. After his doctorate in 1942, Herold was employed at the RCA Laboratories in Princeton, New Jersey, where he organized and managed all Sarnoff projects. In 1949 at the RCA, Law drafted a prototype of a kinescope which could get a picture somewhat larger than 100 cm². In March 1950 RCA publicly demonstrated the operation of the prototype of cathode ray tubes with a shadow mask that was first produced in the following year. In 1952, the project was compiled by the Americans Lawrence, Luis Walter Alvarez and McMilan. Lawrence won the Nobel Prize for Physics in 1939, Alvarez in 1968, and McMilan got his Nobel prize for Chemistry in 1951.

The television's development accelerated the development of electronics. After the jump in the late 1940s, the growth in electronics production was also five times higher than the average growths in the US industry in the next decade. The total amount of sales doubled between 1950 and 1960. Table 27-1 is an overview of major events in the developments of television.

Table 27-1: The First Century of Television (time, world events, Slovenian Contributions)

1817 - Berzelius discovers selenium
1837 - Becquerel discovers photocurrent on selenium illumination
1843 - Bain's picture telegraph
1845 - Faraday discovers the rotation of a polarization plane of light in a magnetic field
1847 - Bakewell copper telegraph
1851 Hittorf investigates the conductivity of selenium
1858 - Plücker discovers the deflection of cathode rays in the magnetic field
1863 - Caselli first transferred the images from Paris to Lyon
1869 -Hittorf investigated the luminous phenomena in the Geissler tube
1881 - Ayrton and Perry used the Faraday discovery of 1845
1883 - Edison patents the thermionic emission
1884 - Nipkow's plate
1887 - Hertz discovers the photoelectric effect
1890 - Fleming explains Edison the discovery of the thermionic emission
1893 - Elster and Geitel's photocells
1897 - Braun published the first discussion on cathode ray tube
1904 - Wehnelt low-voltage cathode ray tube

1906 - De Forest's triode
12 September 1906 - German patent: Dieckmann and Glage use cathode ray ruby for the broadcasting of the letters and images
1907 - Rosenthal used photocell in his optical telegraphy
1907 - Rosnig's Television in St. Petersburg
1908, 1911 - Campbell-Swinton Television in England
1910 - Lieben's Triode 1912 Nardin's relé
1919 - Mihály demonstrates his TV system in Budapest
1922 - Korn transmits images across the Atlantic
29. 12. 1923 - Zworykin's First Patent TV, USA, Recognized 20. 12. 1938
21. 6. 1924 Germany - Karolus TV System
1924 - Ardenne's Receiver and Transmitter with cathode ray tube
1925 - Biard's transmits simple images of several kilometers far away
21. 3. 1925 - Jenkins transmits simple images of several kilometers far behind the patent, recognized in the USA 20. 9. 1927
8. 11. 1925 - Radiotelephot in Leningrad
18. 10. 1926 - Bush equations for electron motion in a field
7. 1. 1927, 17. 4. 1928 - Farnsworth analyzer patented in USA
1928 - Richardson receives the Nobel Prize for exploring the thermionic emission
1928 - Mihály & Karolus-Schröter in Berlin Codelli's TV-system 18.5.1928
1929 - Demonstration of color TV in Bell Labs
16. 11. 1929 - US, 22. 2. 1938: Zworykin's kinescope
27. 9. 1930 - Germany, 23. 3. 1933: Schröter's transfer of "half-sized" pictures
13. 11. 1931 US, 26 11. 1938 - Zworykin's iconoscope
1932 - Šlebinger's patent
1935 - The receiver for color television by Austrian J. Nagler
1946 - Orthicon
1947 - Super orthicon
1948- Institute of Electrical Connections in Ljubljana
1950 - Vidicon
1952- color television at RCA: Lawrence, Alvarez and McMilan
11. 10. 1958 - Regular public TV-Broadcasts in Ljubljana

27.6.11 Television in Slovenia

The Bosnian Croat Josip Slišковиć (1901 Mostar-1984 Vienna) worked as an engineer for the firm Kapsch & Sons in Vienna. He finished his Grammar school in Mostar and studied at Viennese Technical high school. He was the first to show television in Austria for his own production of shadows. He scanned his pictures with a Nipkow's plate and photocell. He lectured about his inventions in Ljubljana and other major cities of the monarchy.³⁰²³ The first one introduced radio on European railways with his "autodyne" device, reported by the Ljubljana-based Slovene. In December 1949 he was the first in Austria to introduce a transistor.

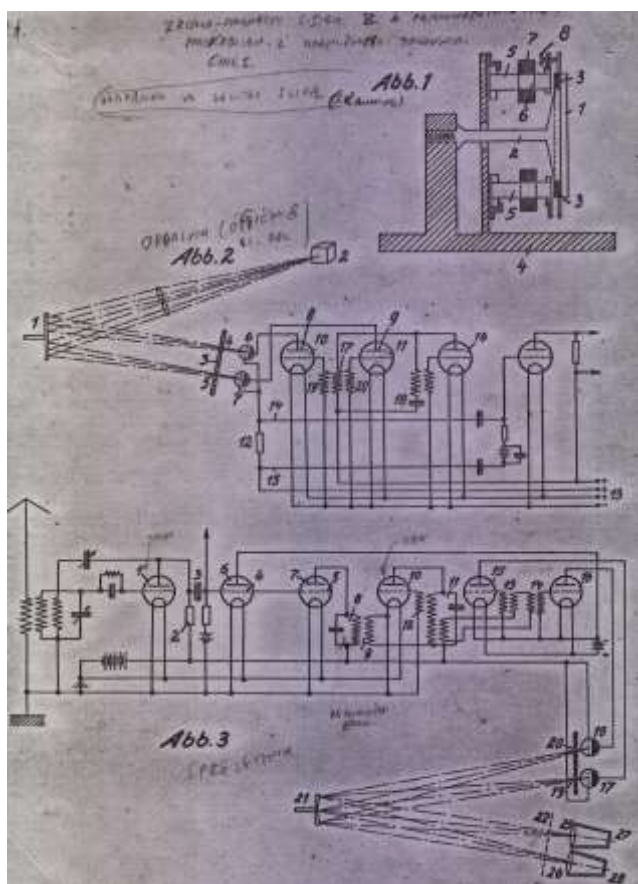

Figure 27-16: Illustrations 1-3 as an appendix to the German Codelli's text, also referring to the 80-page long Codelli's typescript, probably mailed to USA (Codelli, SI_AS 791, box 19)

27.6.12 Codelli's Television

Parallel to Nardin's (* 1877) work at the Ljubljana university and Slišковиć's (*1901) novelties, the

³⁰²³ Codelli, box 19.

other inventors, especially Nardin's two and half year senior Codelli, developed their networks in Ljubljana. Codelli was aware of Slišковиć's merits and well enough to write few page long notes about "our compatriot Slišковиć" among his papers.

Anton III baron Codelli von Fahnenfeld (22. 3. 1875 Naples; † 26. 4. 1954 Porto Ronco near Ascona) was born in Naples in Italy to a Carniolan noble family of Italian descent just because his poor father had to put his anchor there to regain health. Anton Codelli's mother was from the family of baron Taufferer who also produced the leading Carniolan jacobine. The authors of Nardin's and other inventors connected with the University of Ljubljana, made Ljubljana the important site of the early age of television development. Among them was the owner of the Ljubljana quart Kodeljevo baron Anton Codelli, who was born in Naples in the Italian family based in Carniola.

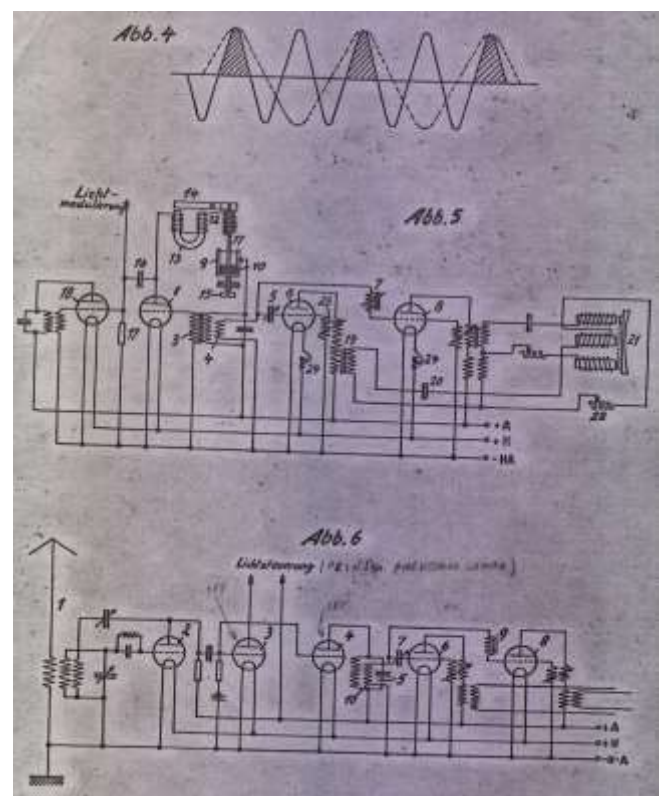

Figure 27-17: Illustrations 4-6 as an appendix to the German Codelli's text, also referring to the 80-page long Codelli's typescript, probably mailed to USA (Codelli, SI_AS 791, box 19)

After his schoolings in Ljubljana, Anton III baron Codelli graduated at the elite Theresian Academy of Nobility in Vienna in 1894. He followed the

example of the deceased father and entered the Austrian Navy; but he left the uniform soon and studied law in Vienna for some time in 1897. In 1898 he patented his first invention, an electric lighter for motor vehicles, and later he designed a heating and cooling appliance for motorists on long journeys. He did not acquire vocal academic titles, however, he could, as a nobleman, devote himself entirely to technical inventions.

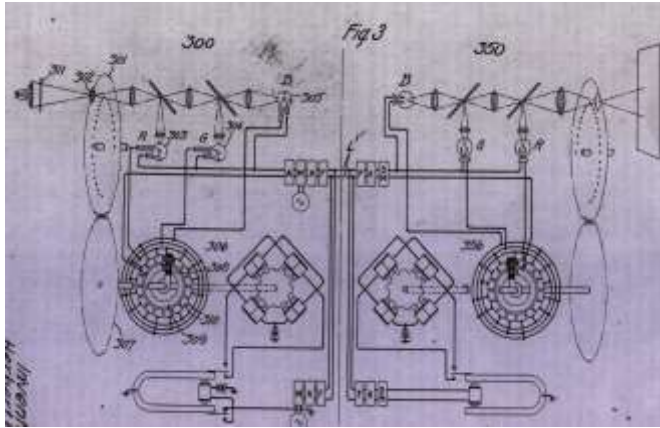

Figure 27-18: Ives' Color Scanner from his patent kept in Codelli's domestic Archive (Ives, 1929, Figure 3)

In 1906, he completed a six-month technical training course at Telefunken in Berlin. From 1907 he worked with his six years senior friend the pacifist Georg Wilhelm Alexander Hans count Arco (1869 Gorzyce, Groß Gorschütz-1940), who was born in the now Polish Upper Silesia. Arco and Codelli did not merely socialize their technical inventor stars of the nobility, but they also shared the way of life of the high nobility in the era of the erosion of its size. After completing the Humanistic Gymnasium in Breslau (today's Wrocław), Arco studied mathematics and physics in Berlin at Helmholtz's class for two semesters. He worked for some time as an active officer, then studied mechanics with Slaby and Alois Riedler (1850 Graz-1936) in Berlin between 1893 and 1898. Arco received his doctorate in Strasbourg and served as an assistant for wireless telegraphy of Adolf Carl Heinrich Slaby (1849-1913) between 1896 and 1898. Slaby served as a professor of electrical engineering at the Technical College in Charlottenburg of Berlin. Following the merger of AEG of Slaby and Arco with the Braun-Siemens Group in the Gesellschaft für Drahtlose Telegraphie mbH (Telefunken), Arco became technical director of the new company in 1903. Siemens had some previous fights with the new

German empire, but both sides decide to settle it down for more profits. Arco retired in 1930 and died in Berlin ten years later.

On 12 January 1908, Codelli described the scanning of a television image with the mirror of the Wehnelt's cylinder by using selenium cells. Codelli asked Telefunken for support. The technical Director of Telefunken Count Arco consulted with colleague J. Schoemlich. On 28 January 1908 Arco answered that selenium was not enough sensitive for light to be used for that performance. The selenium could not follow the rapid changes of light luminosity and does not give a sharp picture. It was necessary to find something faster while the use of Braun's cathode-ray tube did not seem to be as obvious choice to him as it seems to us today.³⁰²⁴

Codelli informed Telefunken via Arco about possibilities for penetration of Berlin capacitors instead of Austrian Svetics's ones sold than on the Habsburg market especially for the navy. Codelli agreed to cooperate with the branch of Siemens & Halske in Vienna, which was closely associated with Telefunken.³⁰²⁵ On April 23, 1908, Arco sent to Codelli the latest Loewe's invention of photo amplifier (enhancement) and Schoemlich's simultaneous reading and photographing system, which was able to read and photograph at the same time. Codelli thanked Arco for his photographic aids in favor of their close long-standing cooperation. Codelli developed the television system after returning from Africa. Codelli continued his research on television on Arco's incentive on 14 December 1927. He collaborated with Schröter, director of the research department of Telefunken in Berlin between 1920 and 1947. The experienced Schröter experimented with cathode "rays" in discharge tube before the First World War. In the first professional paper published in the new Fernsehen magazine, Schröter submitted the description of use of a cathode ray tubes filled with argon at a pressure of a hundred or thousand mbar for both reception and

³⁰²⁴ Count Georg Wilh. Alex. Hans Arco (1869-1940), letter mailed to Codelli from Berlin to Ljubljana on 28. 1. 1908, 4 pages; Letter to Codelli mailed from Berlin to Vienna on 23. 4. 1908, 3 (SI_AS Codelli, Box 20); Telefunken's Letter to Dr. Schapiro mailed on 15. 9.1930, 2 pages (SI_AS Codelli, box 19, translation published by Wedam, 1977, 120).

³⁰²⁵ Arco, letter 12. 1. 1908.

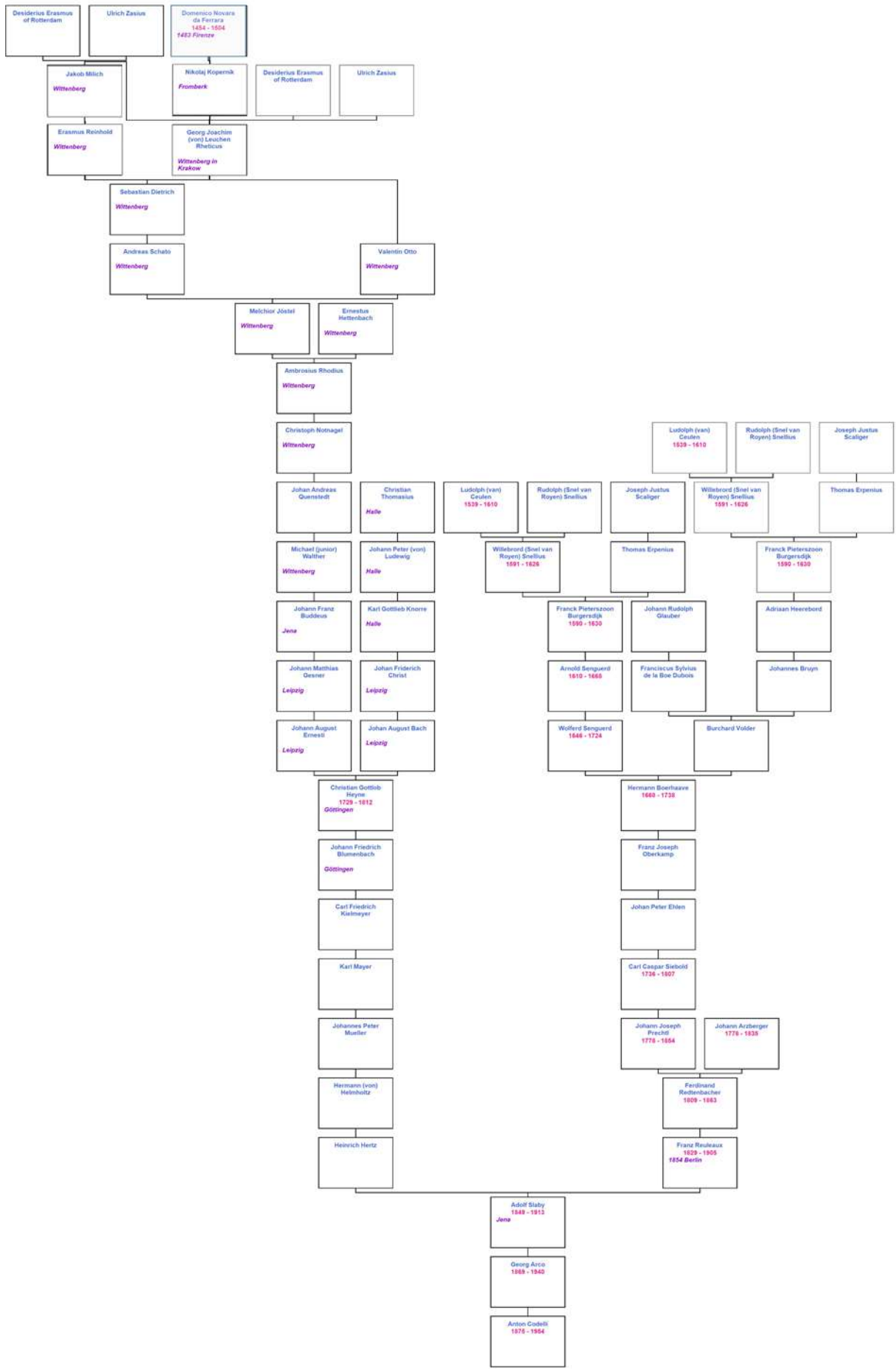

Figure 27-19: Academic ancestors of Codelli up to Hertz and Boerhaave

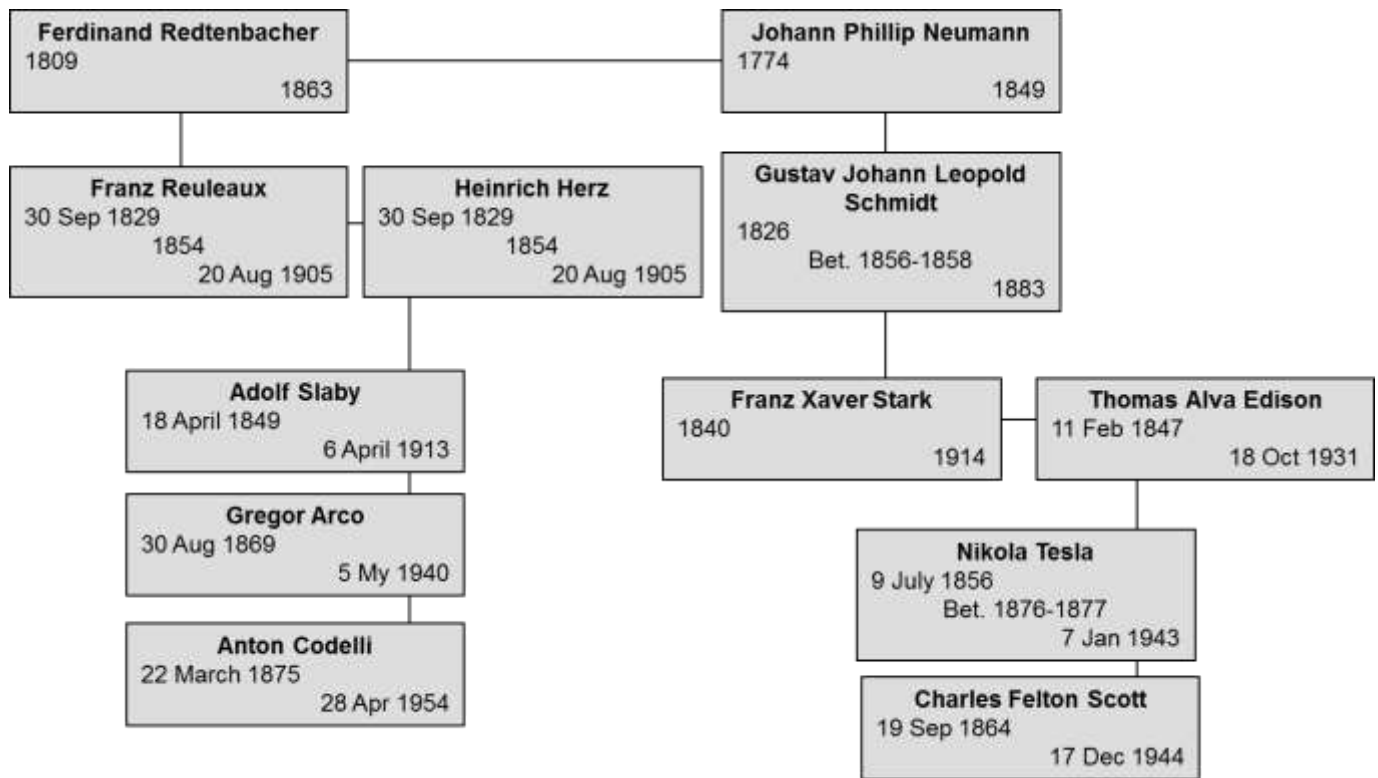

Figure 27-20: Academic ancestors of Codelli up to Redtenbacher

scanning of the image.³⁰²⁶ In the same volume of *Fernsehen* magazine, Codelli described his television system without a cathode-ray tubes.

On 27 September 1930, Schröter applied for a patent designed for the reproduction of "half-sized" images with the successive alternation of barrels and odd rows recognized as his invention in Germany on March 23, 1933. Together with Knoll, he investigated the transmission of electronic images in the Telefunken Television Laboratory in Berlin and published several books and encyclopaedias on television.

On 18 May 1928 in Germany, Codelli patented the reproduction of images along the spiral. On 22 June 1928, he concluded negotiations with Telefunken's agents represented by Schapiro and Schröter. Telefunken has redeemed and bought out 60% of shares of the rights to Codelli's television system for the whole white world except for the USA. Until then, Telefunken owned only Karolus' television system, which Telefunken intended to supplement with Codelli's inventions.³⁰²⁷

³⁰²⁶ Schröter, 1930, 4; Schröter, 1930, 246.

³⁰²⁷ NUK, Manuscript department, reference code: Ms 1397, III (155).

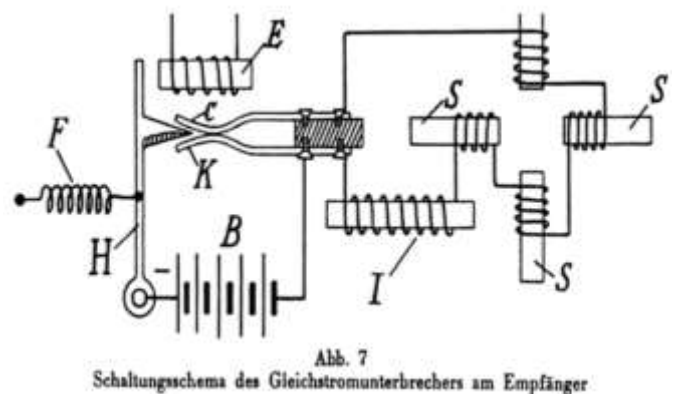

Figure 27-21: Seventh sketch of a direct current receiver from Codelli's publication (Codelli. 1930. *Ein neues Fernseh-System*. *Fernsehen*. 1 / item no. 3, p. 107–114, here p. 113)

On 14 November 1928, Codelli sent to Schröter a description of his TV with John Kerr's (1824 Androssan in Scotland-1907) cell used in a same way as in the Karolus' system. With Codelli's help, they made the prototype device in Berlin in six months. On June 22, 1929, the director Dr. Karel Schapiro at Telefunken issued a laboratory certificate for production of a prototype television according to Codelli's patent for Telefunken, for which 25,300 marks were granted and approved, of which 13,000 marks were given for Codelli's

compensation and for the reimbursement of his travel expenses from Ljubljana to Berlin. The final used price of the device became almost twice as high because of additional parts, while Codelli had at least temporarily all luck in front of him.³⁰²⁸

On 17 January 1930, Codelli described a scan with a Nipkow's plate with two spiral holes in a total of 25 coils. For them, Schröter's photocells were installed, which worked alternately. The device was carrying and transmitted 12.5 images with 2500 elements per second. The streams of photocells were strengthened by the De Forest's Audion, produced at Telefunken. In place of Nipkow's panels, a L. Weiller's mirror wheel was also provided for use, as it was designed for the first time in 1889.³⁰²⁹

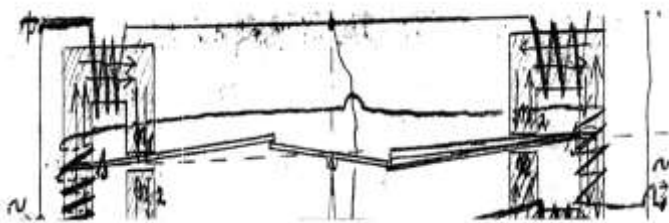

Figure 27-22: Sketch of the television system from Codelli's letter to Schröter on 14 November 1928 (Archives of the Republic of Slovenia, SI_AS 791 Manor archives, Turn by Ljubljana, box 19)

In the case of spiral scanning, a small difference in the staged phase at the outer edge was known in the center of the image, while the normal scanning of the phase difference itself was eliminated. Therefore, the damping and frequency of their own fluctuations and oscillation of the mirror on the receiving and transmitting sides of Codelli's system were exactly the same, which was practically unfeasible for the technology.³⁰³⁰

Recording of an image with a mechanical scanner with detectable persistence caused loss and damage to the image. Only the recording-shooting along a spiral in the Codelli's system can accurately transmit images in a mechanical television. Therefore, the damping and the frequency of their

own oscillation of the mirror on the receiving and transmitting sides of the Codelli's system were the same, which was not practical issue for then available technology. The recording of an image with a mechanical scanner with detectable persistence caused loss and damage to the image.³⁰³¹

In 1928 and 1931, Codelli patented his stereoscopic electric "far-sighted" vision in all major European centers and in Canada, but he did not succeed in the United States. On 10 November 1933, the chairman-President of the Ljubljana section of the Association of Engineers and Architects, Milan Šuklje, considered that Codelli's lawyer Abrahamson made a mistake when he missed the deadline for the application and payment of the request-requirement for an American patent on January 23, 1931. Due to the incorrect filling and irregular application on 25 June 1927 and on 29 December 1930, under no. 60718, Codelli's patent in the USA was rejected on 18 August 1932. In 1928 and 1931, Codelli patented his stereoscopic electric "far-sighted" in all major European centers and in Canada, but he failed in the URnited States. Nevertheless, the company of Tesla's patron the multimillionaire J. Pierpont Morgan named Shortwave and TV Corporation asked Codelli's Washington lawyer Emil Bönnelyck for information on Codelli's patent on 11 October 1932, but later, on 20 January 1933, J. Pierpont Morgan refused to buy it.³⁰³² Tesla's "friend" J.P. Morgan senior was already dead at that time, so that his son with the same name replaced him.

The competitors were harsh and Codelli also had to show teeth sometimes. Among Slovenians on the Slovenian soil Codelli was the first to use the cathode ray tube electronically in television only in cooperation with the Ljubljana electrician and radio technician Franci Bar (* 2. 12. 1901 St. Anton by Trieste-24. 11. 1988 Ljubljana). After the Italians took over Trieste, Franci Bar and his family moved to Ljubljana where his father opened a store on Cankarjevo nabrežje on the banks of Ljubljana River in 1919. In 1931, Franci Bar took over the store with the help of his wife and brother. They were selling stamps, radios, gramophones, typewriters and photo-apparats and

³⁰²⁸ AS, Codelli, box 19; NUK, 141, Nr.3458, Nr.3408 III.

³⁰²⁹ Friedel, Israel, Finn, 1930, 15; Codelli, Ein neues Fernseh-System, Fernsehen 1 (1930), No. 3, 110-111; Grabnar, 112; Weiller, 1889 (quoted according to Schröter, 1956, 19).

³⁰³⁰ Schröter, 1932, 52-53.

³⁰³¹ Ardenne, Über Helligkeitssteuerung bei Kathodenstrahlröhren, Fernsehen, 3 (1932) 18.

³⁰³² Grabnar, 1977, 113.

they loved to repair them. Franci Bar became the fascinated radio-amateur and photographer. He especially excelled as the best cave photographer of his times and as a very active member of the Society for the research of Caves in Ljubljana which was reorganized after the publications of Pavel Kunaver in 1924. Besides Franci Bar, the other active members were Valter Bohinec, Srečko Brodar, Marjan Bukovec, Ivan Dolar, Jovan Hadži, Ljudevit Kuščer, his son Ivan Kuščer, Roman Kenk, Ivan Michler, Hubert Pehani, Ljubo Podpac, Egon Pretner, Ivan Rakovec... The leading biologist Jovan Hadži (1884 Timisoara-1972 Ljubljana) spoke Slovenian language with a strange Serbian accent, but he was a great expert. Franci Bar from the practical side and Albin Belar from the academic side were certainly the best collaborators which Anton Codelli could find in Ljubljana between the Wars. Certainly, the baron Codelli was a high society for all those other Ljubljana guys, but those old class social rules slowly collapsed under the pressures of modern networks. Codelli family members still mostly married the nobles, but he also had sympathies elsewhere and certainly avoided class rules in his research of the electromagnetic designs. Codelli did not specially like Yugoslavia as his son Karl Anton Codelli was shot death while he was trespassing the railway track near their family home which happened to be also near the military stronghold in Ljubljana in 1921. On 14 March 1930, Codelli announced in his response to a month-old Schröter's letter that the TV equipment from Berlin should be delivered to Franci Bar's store address on Mestni trg (City Market) no. 5/I in Ljubljana.³⁰³³

Schröter exhibited a mechanical system in Berlin on 11. 5. 1928 and he advocated the use of a cathode-ray tube in August 1930. On 27 September 1930, Schroter filled a patent for the reproduction of images by sequentially changing even and odd rows, which was recognized and granted in Germany on March 23, 1933. Together with Knoll, he studied the transmission of electronic images in Telefunken Television laboratory in Berlin. He published several books and encyclopaedias on Television, which Codelli used. On June 18, 1928 Codelli patented his invention in Germany, and

³⁰³³ Grabnar, 1977, 112; Codelli, AS, box 19; NUK, 134; (Boštjan Kiauta, 2015. Spomini na mladostno "entomologiziranje" v Ljubljani med drugo svetovno vojno in neposredno po njej (1941-1953). *Erjavecija* no 30: 31.

then elsewhere including his homeland Yugoslavia. Thus, at the same time Schröter and Codelli both adopted and approached the "American" version of electronic television, which soon prevailed.

27.6.13 Codelli's Cathode Ray Tubes

Codelli as the first used the invention of the cathode-ray tube in television in Ljubljana. In his legacy kept in ARS there are numerous copies of foreign patents, from which he appeared to be well-versed in electrotechnics. He knew that the electronics without the cathode ray tubes dogged his success in the United States. That is why both Codelli and Schröter began to use cathode-ray tubes in the late 1920s for their television, which best suited the Russian Zworykin in the United States RCA form. Codelli used Braun's cathode ray tubes which resembled Farnsworth's designs with photocathode. Codelli arranged his basic idea of recording and receiving the image along the spiral so that the picture had denser elements in the middle than on the edges. Farnsworth was of course the main Zworykin rival and Codelli's choice was well thought out. Of course, Codelli would need money to make a prototype after the Telefunken gave him funds for the mechanical version of the device in 1929. He developed a television device with a single line – but one that formed a continuous spiral on the screen. Codelli based his ingenious design on his understanding of the human eye as he knew that objects seen in peripheral vision don't need to be as sharp as those in the center. His television system, whose image was sharpest in the middle, worked well, and he was soon able to transmit images of his third wife married in 1923, Ilona von Drasche-Lazar de Thorda (Ily Lázár, * 4 May 1904 Budapest). The success did not help much as the couple divorced few years later in 1935 and their son Anton (Sikst) Sixtus Rudolf Codelli von Codellisberg, Sterngreif and Fahnenfeld (* 21 November 1923) joined the Nazis whom his father hated.

The new settlers of former Land of Native Americans began to dictate their criteria to their European ancestors. The former Land of Indians' guys began to dictate its electronic criteria worldwide. Codelli patented the television while Codelli knew little about the Russian-American alliances in RCA, which soon brought television to our homes.

After returning from Africa, Codelli re-joined Telefunken again, but in the first years he did not get contact news from abroad. In Germany, he patented the reproduction of images along the spiral. With Codelli's help, they made the device in Berlin in six months. Codelli patented his stereoscopic electric "distant vision" in all major European centers and in Canada, but not in the US. As the first one in Slovenia he started using a cathode-ray tube in television. To gain his support in the USA, besides mechanical scanning and mobile optical devices, Codelli described the purely electronic TV with no moving mechanical parts as his third option.

In an electronic version, Codelli retained the basic idea of recording and receiving an image along a spiral with denser elements in the middle than at the edges. To gain a foothold in the US, Codelli described, in addition to mechanical scanning and mobile optical devices, the third option on 80 pages. He filled 61 patent claims for a fully electronic television without movable mechanical parts. He used Farnsworth's design including Braun cathode ray tube with photocathode. Codelli reproduced the image with a strong Braun's cathode ray tube shaped as a funnel with a punctured anode and a slightly convex fluorescence display. The cathode in the form of a concave mirror had a focal point in the middle of the screen. The recording tube was a glass receptacle, divided by a glass pan into two emptied spaces, of which the other was Braun's warmed cathode ray tube.³⁰³⁴

His cathode ray tube had two cathodes for electron emission and one anode. Codelli has already used the term electron³⁰³⁵ for cathode rays, although he had repeatedly written about the cathode ray deflection in his typewriting.³⁰³⁶ In one place, he explicitly described the transmitter from the long Geissler's cathode ray tube on the same page with a diffused reflector made of glass.³⁰³⁷

In the electronic version of his television, Codelli also retained the basic idea of recording and receiving the image along the spiral so that the

³⁰³⁴ Codelli, AS, box 19, 11–12, 15, 16, 38 (75), 44 (77–78), illustration 6 (preserved in German language abb. 6)

³⁰³⁵ Codelli, AS, box 19, 16, illustration 10 (today they are almost lost and up to not fit abb. 10, which shows L. Weiller's mirrordrum).

³⁰³⁶ Codelli, AS, box 19, 75.

³⁰³⁷ Codelli, AS, box 19, 67–68.

image had denser set of elements in the middle of the screen than on the edges. The idea was based on the physiology of the eye, and among the first it was used by A. Ekström in his Swedish patent no. 32220 of 24 January 1910 bought by Bell labs and bettered by the chief of physics research and cosmic rays as well as X-rays in Parisian Louis de Broglie labs Alexandre Dauvillier (1892 Saint-Lubin-des-Joncherets-1979 Bagnères-de-Bigorre) in 1926. The similar design was developed by the Scottish expert Alexander McLean Nicholson in patent no. 1470696 in New York in USA on 7 December 1917 and 16 October 1923. As leader in the development of piezoelectric crystals and vacuum tube oscillators in television and radio for the Bell labs in 1917-1923, American Telephone and Telegraph Company and the Western Electric Company Nicholson used Braun's cathode ray tube electronic device for his receiver, in which a stream of electrons on a fluorescence screen drew a picture of Archimedes spiral. The MIT graduate Transmission and Development Engineer of ATT Otto Bernard Blackwell (1884-1970) from Plandome northeast of Queen in New York city and J. Herman from New York as assigners to American telephone and telegraph company applied for US patent for similar spiral scanning Method and Apparatus for Television on May 7, 1925. Their patent no 1,624,918 was granted on 19 April 1927. Blackwell was later vice president of Bell labs and assistant vice president of American telephone and telegraph company.

The engineer with his University diploma Paul Kirchhoff from Frankfurt on Main filed his version on 6 September 1925 bettered with his elemental scanning area oscillated rapidly in direction transverse to main scanning direction for a German patent filled on 7 October 1930 and granted five years later. After their prolonged negotiations due to the Telefunken's opposition, Kirchhoff finally refused to compete with Codelli and Telefunken in Berlin on 14 August 1936. The Jewish Berliner university professor of physics Arthur Korn's (1870 Wroclaw-1945, Jersey City, New Jersey) reedition of the former Eilhard Wiedemann's assistant Bruno Glatzel's (1878 Berlin-1914 by Verdun) manual published in 1931 cited French patent no. 570825 of September 14, 1923, February 21, 1923, February 7, 1924 for scanning a spiral with Braun's cathode ray tube electronic device.³⁰³⁸

³⁰³⁸ Codelli, AS, box 19, 74–75, request 45.

Competitors were harsh and Codelli also had to show muscles sometimes. Unfortunately, the key to success was waiting beyond the Atlantic. That's why he wrote to the Americans in somewhat modernized following narration:³⁰³⁹

"I installed two photocells with anodes connected through resistors to the openings in the screen. Each of the cathodes was connected to the grids in the other two tubes. The glowing cathodes were interconnected with the flow of the current, which is then further amplified. This is then through the resistance (pictured on Codelli's figure as point no. 12) led to the next stage of amplification. During one oscillation of the circuit the photocurrent passes from the coil and the condenser through one and then through the second cathode ray tube.

The circuit is tuned to a frequency equal to the product between the number of pixel points and the number of broadcasts per second up to 0.18 MHz. The receiver was tuned in such a way that the amplifier (de Forest's audion) produced a continuous stream of currents with the frequency of the image elements, which are through a condenser converted to alternating current of the same frequency on the grids of two cathode ray tubes.

The anode current of the cathode ray tube runs a current through a circuit tuned to the frequency of the current of resonance oscillation of the elements of two images with a large amplitude. This high-voltage alternating current is used as an anode current in the second cathode ray tube (presented in Codelli's illustration with a point no 10).

In this circuit (presented in Codelli's illustration with a point no 11), the frequency is twice as low as in the previous circuit 8. Circuit 11 is in a known manner in the feedback relationship to the grid current of the cathode ray tube 10 via the transformer 12. Because of this feedback every other positive pulse current of the alternating current of the anode is damped due to the negative charge of the grid.

³⁰³⁹ Codelli, AS, box 19. The numbers in brackets indicate the pages of Codelli's typescript. The illustrations noted in typescript did not survive the naughty greedy customers of the archive.

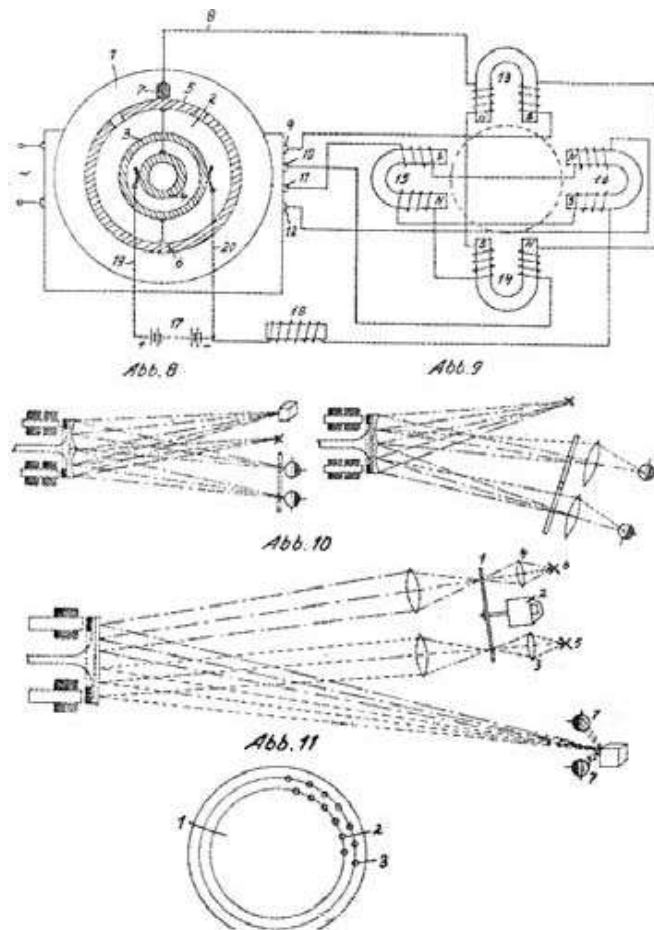

Figure 27-23: Figure 27-23: Figures 7-11 as an attachment to the Codelli's typescript written in German language. Except for figure 10, those illustrations partly also correspond to now lost illustrations of 80 pages long Codelli's English language typescript, whose copy was probably sent to the United States (source: ... circuit 11 with the half-frequency (Codelli's USA patent application, Figure 4)

Since the negative phases of the alternating current cannot be transmitted through the cathode ray tube, only the currents resonant with the oscillating circuit 11 with the half-frequency (Codelli's Fig. 4) remain. The current in the oscillator 11 is connected to the grid network current of cathode ray tubes 15 and 16 via the transformer 13 and 14 so that at the same time one of the two grids in the cathode ray tube (15 or 16) receives a negative voltage and the other receives a positive voltage relative to the corresponding cathode. When one (15) of the gas-discharge lamp (17) is intended for the image on the left eye, connected to the row, another second picture frame for the image on the left eye is connected. Both cathode ray tubes with their grids are positioned parallel to the anode current of the tube 6, whose grid is regulating the

power of the current and thus the degree of illumination of the gas-discharge cathode ray tube in connection with the illumination of each element of both images, while the cathode ray tubes 15 and 16 operating in the phase delay, split the picture elements to the left and right eye.

In front of the gas-discharge cathode ray tubes are perforated diaphragms in the form of equilateral triangles. With the concave mirror 21 of the receiver, we project two real pictures of the apertures in the diaphragm onto the surface where they are intercepted and can be observed with a conventional stereoscopic apparatus. Two images can be observed with the appropriate synchronous motion of the transmitting mirror and receiving mirror. The transmitter projects two real-images while moving across its corresponding devices on the screen so that all parts of the screen can reflect their rays on the photocell. In this way, both images of the diaphragm on the receiver, whose light intensity is controlled in the same way, move in the same way, so that two images appear.

During the oscillating period of the alternating current the direction of circulation changes, and instead of the circle we get an ellipse which becomes more steeper, with greater current changes in the unit of time. The diagram for the moving mirror is described as follows: the triode generator and the oscillating circuit tuned to the natural frequency of the mirror is generated in a known way using an alternating reverse link current. With the transformer 4, the alternating current voltage is transferred to the grid of the cathode ray tube 6 through the variable capacitor 5, and on the other side to the cathode ray tube 8 via the variable damping coil 7, while the phases of the two alternative currents are relocated. The anode current of the cathode ray tube 1 is transmitted over the circuit breaker, which interrupts the current after a few cycles of the circuit 2. This can then be damped due to natural attenuation. After many such oscillations, the anode circle can be closed again by interrupting the anode current, which is then repeated. The interrupter consists of an iron container filled with mercury in which the iron rod with its spiral winding keeps a frequency of the circuit in resonance with the number of images broadcasted per second. The conductor connects the spiral spring with the winding of the electromagnet.

The level of mercury in the container can be raised or lowered. Variable jets of anode current in the cathode ray tube 1 due to the variable current 2 are transferred to the grid of the transmission cathode ray tube via the capacitor 16 and the clutch of resistor 17 as long as the interrupter (circuit breaker) holds the closed circuit. This grid affects the modulation of the transmitted wave over the amplified current from the photocell. So long as the anode current of the cathode ray tube 1 is interrupted, it affects only the transmitting electrode 18 just with a slight modulation, and during this time, the damping circuits 2 continue to control the cathode ray tube 6 and 8.

As soon as the anode voltage is connected to the cathode ray tube, the alternating currents shifted from their phases, put the transmitting mirror into a raising spiral oscillation to the maximum values that, due to the large natural damping of mirror, are soon reached.

During this time, the transmitting electrode has the same frequency as emitted by the modulated waves. The anode current of the tube generator 1 is then interrupted. The spiral has a logarithmic shape.

In the receiver, 6 modulated waves emitted from the transmitter during the cascading spiral of the oscillating mirror and modulated with the oscillation frequency of the mirror are received by the antenna 1 and translated in a known way to the amplifier (audion).

The resulting low frequency pulses are then translated in a known way to the grid of the cathode ray tube 3 and to the grid of the cathode ray tube 4. The anode current of the cathode ray tube 3 is used to operate the gas-discharge lamp (according to Codelli's USA patent application, Figure 4).

In the anode current of the cathode ray tube 4, we put the resonant circuit 5, which is tuned to the frequency of the oscillation of transmitting mirror. Through the transformer 10, the alternating voltage of the oscillator 5 is transmitted through the grids of cathode ray tubes 6 and 8: through the first by the condenser, and through the other by the self-induction, as previously described.

The synchronized mirror movement is formed automatically with the correct adjustment of the oscillator current. By the generation of the current to the coil of the transmitting mirror, as well as the receiving mirror, they influence the grids of cathode ray tubes which are simultaneously controlled by the emitted current pulses.

The synchronization of currents can also be obtained by using the transmitter and the receiver alternating flux currents from the magnets on the mirror generated through the frequency reduction according to the previously described methods. An electromagnet can also be used instead of a permanent magnet.

We can use the Nipkow plate with two spirals of holes for which two photocells or gas-discharge lamps are installed, each for their spiral, where they alternate. We can also use Weiller's mirror drum.³⁰⁴⁰ We also obtain two real images of the object for stereoscopic transmission, which is influenced by two concave mirrors around the mirror carrier (Codelli's USA patent application, Figure 8). Weiller's mirror drum therefore also replaces the circular setting of the concave mirrors.

The transmission of the stereoscopic film can also be used to control the light rays. In the case of stereoscopic broadcasting of objects, the illumination is insufficient. However, we can also use controlled normal light that falls by two different angles.

The diffusely reflected light then falls on a few nearby cells (Codelli's USA patent application, Figure 10). The sources of light are positioned in such a way that the light can only go through a certain series of openings.

Codelli also used similar combination of parts for his receiver. Therefore, Codelli claimed that he invented:

1. A method for stereoscopic television, where the transmitter, in turn, transmits image elements that are divided into their elements and are distributed to images suiting the left and right eye.

2. The method according to claim 1, wherein the transmitter is illuminated from the two sides at a slightly different angle from where the image is projected onto a stationary display. This has in its middle two small openings and photocells behind them, which are activated sequentially.

3. The openings on the receiver have the form of an equilateral triangle.

4. Two real images are copied by two hollow mirrors, placed with a side in front of a working distributor.

5. Controlling the light rays, determined by the falling of light on the moving distribution mirror through two slides or films above two photocells, which are activated sequentially.

6. Modification of a method 5 with a single source of light.

7. Two successively lighting up sources of illuminations are diffusely reflected by the object, so that one or more photocells are consecutively visible to one or the other eye.

8. On the receiver are the real images of two successively activated light sources projected through a moving dispensing (distributing) mirror through a stereoscope.

9. Change of point 8, where each lens is equipped with a cathode ray tube and a control hole at the distance of its focal point.

10. Device for sequential activation of photocells in the transmitter or of sources of light in the receiver. Two parallelly connected photocells or two sources of light are characteristic. The electrodes are placed in series. An alternating voltage is applied on them so that only one cathode ray tube transmits current in one phase, while in the second phase only the second cathode ray tube transmits the current.

11. An alternate activation of the photocells in the transmitter, characterized by two openings on the screen in the transmitter or opposite to the light source on the receiver movable diaphragms to cover one of the openings for such a space of time as is necessary for the transmitting of image element and opening a second aperture to

³⁰⁴⁰ According to Codelli wrongly noted as Weller's wheel, in fact described by the French worker Lazare Weiller in 1888 in the publication about "phoroscopus" (Swift, 1950, 49; Fisher, 1996, 85).

transmit the beams towards the second element of the images through said pierced plates.

12. A device for synchronizing the distribution of individual image elements for the left and right eye so that the pulses passing through the transmitter and constituting the picture element of the receiver produce fluctuations in the electric resonant circuit tuned to the number of elements of the image per second or its half.

13. Method of carrying out the described synchronization for individual image elements.

14. A method for reducing the frequency defined by the high-frequency alternating anode current through a triode by which the pulsating low-natural frequency circuit is connected in the series so that in a known way it affects the grid by means of a feedback link. Thus, only the impulses that are suitable for generating low frequency oscillations in the circuit can pass through the cathode ray tube.

15. A device capable of varying frequency.

16. Magnetic system with few magnets which are surrounding the mirror so that they change the amplitude of the alternating current (in the case of permanent magnets) or they are changing the amplitude of the DC current, if we use electromagnets.

17. Rotating magnets exhibit their greatest attraction of the iron frames of the mirror only during certain periods of alternating current.

27.6.14 Problems with Politicians

Up to 1933, Codelli's patent applications failed in the US, and then the Nazi nationalists took over the control of the German state, which was criticized by careless Codelli. Unfortunately, Codelli lost the German support, therefore he couldn't compete against the television of the American RCA anymore. Codelli's opposition to the Nazi regime in Germany caused the interruption of his cooperation with Telefunken. Without the Telefunken, however, the amiable baron of Ljubljana could not rival the emerging television industry in the US, although he sold out a large part of his estate on Kodeljevo. Codelli sold most of the property of his Kodeljevo home, but the

Americans picked up best of the invention of television anyway. In this, he was most comforted by the fact that television was not his only hobby: he owned the first (and second) car on Slovenian soil, paid for the first live action African film to be shot with a dreamy German star in Africa and he even replaced three noble women as his wives. After the war, his castle Turn along the Ljubljana River was nationalized, while the well-informed Codelli folded up his tents to settle down in Switzerland before the end of the war. We do not know yet whether he was watching television there, which, unfortunately, (yet) did not follow his spiral innovations.

Codelli's opposition to the Nazi regime in Germany caused the suspension of Codelli's cooperation with Telefunken. In 1930, the pacifist Arco retired and died in 1940, so, Codelli failed to get much German support without his friend Arco. Without Telefunken's support, Codelli was not able to deal with the emerging television industry in the US, although he sold out a large part of his property at Kodeljevo in Ljubljana.

The only true early Slovenian TV breakthrough was achieved by the Ljubljana baron Anton Codelli, who already used the term electron instead of a cathode rays, although he repeatedly wrote about the cathode ray deflection in his US Patent application. He explicitly described a transmitter designed from a long Geissler tube placed on the same surface with a diffused reflector made of glass. The Ljubljana vacuum research was therefore born at least on Kodeljevo, if we ignore the school labs attempts of Codelli's predecessors. In Codelli's and his father's military base in Pula bravely served a doctor and high naval officer Jožef Potočnik (1841 Upper Razbor by Slovenji Gradec-1894 Pula), who fought at Vis under Tegetthoff's command and became a general. He was the father of the inventor of the geostationary satellite the engineering captain Herman Potočnik - Noordung (1892 Pula - 1929). The naval officer Karl Jožef Baron Codelli (1846-1878 Pula) also served in Pula. After his graduation his son, a navy officer, an inventor of the television Anton Baron Codelli (1875-1954) from Kodeljevo worked there in Pula from 1894 until 1897. Although Idrija and Ljubljana professor Nardin patented a lot in the direction of Tesla's ideas, the Ljubljana Baron Anton Codelli is the only one among Slovenian inventors at least remotely comparable to Tesla.

Alongside Tesla's 170 patents, Codelli also filled many patents, although he did not have enough experience in the US. Codelli was almost two decades younger than Tesla during the rapid development of electrical engineering, when the new inventions were catching each other. Codelli studied cathode ray tubes primarily as a device for establishing his model of spiral television image broadcasting on the US market; Codelli devoted less attention to Tesla's innovations. Since they were moving in the same electrotechnical environment, Tesla and Codelli had many common friends and acquaintances. Tesla corresponded with Adolf Slaby in 1901 and 1903. As a professor of electrical engineering at the Technical College in Charlottenburg, Slaby used German translation of Tesla's work as the basis for high-frequency techniques. Slaby also taught George Count Arco. Arco soon corresponded with Tesla himself. At the same time, Arco became a friend and major Codelli's associate in the Berlin based Telefunken. Thus, Codelli was at least indirectly associated with Tesla, which, according to his inventive approach, worked and invented very much like Codelli. Of course, Codelli was the son of a rich man, but he wasted his Kodeljevo property on the altar of science.

Codelli's main invention was television. He constructed it so that the image flows spirally. His density of the picture elements (pixel) with their resolution in the center is greater, since the lower density at the edges does not disturb the observer. Codelli therefore also became the expert physiologist of the vision which might affect his frequent marriages. His patent was purchased by Telefunken, which enabled Codelli's journeys to Berlin. When Hitler came to power, Codelli was not too much fascinated and after the year his connections with Telefunken broke up. Otherwise, he patented across Europe and Canada. But when he wanted to obtain patent in the USA, he failed.

Tesla's USA fan was a wealthy man, J. P. Morgan, who otherwise supported Tesla until he realized that it would not be possible to extract any money from Tesla's wireless. The other Morgan, Avigdor M. Vic Morgan of Belmont Massachusetts, however, initially supported Codelli. Codelli's patent was also modernized, but in the USA Codelli had a competitor, the Russian Zworykin, who had stronger patents in USA. This television did not bring Codelli any money, but he also had

the first car, he also created terrible losses, and sold one piece by piece of his Kodeljevo property in Ljubljana. From Togo, he brought with him a black man, who was maltreated while he walked around Ljubljana because the locals thought he was painted with a shoe polish. However, the Negro responded by saying that the local Ljubljana people were uncultured bush folks.

27.6.15 Other Codelli's Inventions

The father of inventor Codelli married his cousin baroness Taufferer, after whom Anton could inherit his technical abilities. Taufferers were an important Carniolan family, which gave more prominent officials, officers and priests, among the latter two writers of Slovenian pious books. They were lower Roman-German nobles, in the 16th century also patricians in Augsburg. In the second half of the 16th century they came to Carniola.

Taufferers gave a powerful stamp on Ljubljana's education and science. The ancestor of Codelli's mother, Baron Maximilian Taufferer, assisted the Ljubljana teacher of mathematics Stainer in exams at the College of Ljubljana. In his library, he had numerous works on mathematical science. He was the elder brother of Cistercian Janez Vajkard later Pater Aleksander, who became the Kostanjevica Abbey and Gorizia Archi-deacon, and was also a member of the Dizma brotherhood of Carniolan nobles. Alexander studied the last year of philosophy in Ljubljana and wrote his exam lectures about general and special physics. In general physics he described the siphon and other water pumping devices. In his paragraph about lightning he narrated about the storms as they happened in Vienna and Ljubljana. He advocated the theory of mercury vapor above the tower in the barometer, although he acknowledged the weight of the air. In special physics he described and draw the systems of Ptolemy, Copernicus and Jesuit Riccioli in the discussion of the Universe. Resembling Kelallur Nilakantha Somayaji (Comatiri, 1444-1544) of the Kerala school or Tycho Brahe, Riccioli imagined somewhat modified the rotation of three planets, Mercury, Venus and Mars around the Sun, while the orbits of the Sun, Saturn, Jupiter, and fixed Stars were centred on the Earth. Unlike Kelallur Nilakantha Somayaji and after him Tycho Brahe, Riccioli retained the Ptolemaic rotation of Saturn and Jupiter around the Earth.

Maksimilijan Taufferer was the owner of the new castle in Peščenik. His bookplates are found in books that later became part of the Lyceum library in Ljubljana. He was the son of Mark Anton Taufferer. The first of his twelve children Inocenc Taufferer became professor of physics at the University of Ljubljana. Inocenc was interested in vacuum experiments, and in September he reprinted Mairan's book about the causes of the mercury fluctuation in the barometer with his own examination thesis included. Five years later he published a German Computing manual. Inocenc's nephew was an officer, a revolutionary and a revolutionary Janez Siegfried Herbert Taufferer. Since he joined the hostile French army, the Habsburgians sentenced him to death by Maria Theresian Criminal Code in Vienna for his alleged insult of the Emperor and the high treason. His influential relatives could not afford to help him in those wartime times.

Codelli used to be a pioneer of film industry. During the World War I Baron Codelli was in Togo and he set up a telegraph for the Germans and financed the first live action African film by the scenario of his mother. His mother was from the genus Taufferer, a baroness from Višnja gora, and his father was a mayor for some time; otherwise the Codelli family originated as Zois and Valvasor from the Bergamo areas. When Žiga Zois' father came to Carniola, he served as Codelli's assistant. Anton Codelli did not study much. He went to the elite noble academy in Vienna, and then did some electrical engineering courses. He also had strong international ties, including those with Tesla, at least indirectly, as they had common friends. He did not exactly correspond with him. Compared to Tesla, Codelli was also 18 years younger.

At the beginning of 1910, Codelli, in financial distress, accepted Telefunken's offer and began building a large radio transmitting station in the then German colony of Togo, in Africa. There, he covered the cost with 46,000 marks and was directly involved in the shooting of 3000 m frames of one of the first African films "Lost Daughter *Weißer Göttin der Wangora* (*The White Goddess of the Wangora*)" in 1913. It was the first live action film shot in Africa, and the main actress was Codelli's sympathy, the beautiful Meg Gehrts (1891-1966). Meg was Schomburgk's wife from 1922 until 1925. Fine crafty inventor Codelli was,

on the other hand, married to a Czech baroness, and he was secretly admiring the brilliant German actress. They recorded their film in the idyllic virgin forests until the World War I was over. The successful radio station had to be put down and destroyed with dynamite by Codelli and the French troops of Togo, while Codelli returned from prison only ten years after his journey to Africa. He brought with him a rich collection of African products which later enriched the Ljubljana Ethnographic Museum.

Miha Čelar's film was recorded on the 70th anniversary of Codelli's death. His African adventures were described. Miha showed how he tried to adapt to the requirements of the American market with the electronic version of his television system and briefly summarized the other Codelli's inventions. In 2017, Miha Čelar produced a documentary and played film about a film project of the baron Anton Codelli. Together with filmmaker and adventurer Hans Schomburgk (1880-1967) Codelli filmed in Togo in 1914 the first live-action film in Africa, which possibly inspired James Rice Burroughs's Tarzan. In the company of three Codelli's female and male descendants and the actor Primož Bezjak, Čelar traced the fate of Codelli's film, brought the remaining artefacts from Togo and Berlin to Ljubljana and used the Green Screen technology to bring to life 15 live-action scenes based on 600 Codelli's museum photographs. A. Codelli's old granddaughter was surprised how the young actor Primož Bezjak could feature as A. Codelli whom his granddaughter remembered only as an old man, but it happened to be just another misunderstanding. Miha Čelar stated that the fact that A. Codelli's great granddaughter was just abandoned by her fiancé mirrors the fact that they are the members of the rotten capitalist folks, but he was wrong, as they were just the members of the elite, just like the film stars loved to marry as much times as possible.

Codelli entered the world of film and television just when it became a novelty recognized and named in America. In these years after the first war, Codelli naturally created new inventions, and due to poor communications, he lagged somewhat behind by the development in the United States. In many respects, the American television has largely developed thanks to Russian fugitives escaped from the Leninist regime, just as the American

nuclear industry was later invaded by fugitives escaped from Hitler's Nazis, and USA again got many useful immigrants after the humiliated destruction of Soviet Union in 1990s.

Codelli has grown with a new era of electrical engineering. He got Karl Benz's car in Vienna and scared the poor folks of Ljubljana with his speedy journeys. Soon, he got tired of the dust of the Carniolan roads, and along with the driver drove to Nice, for the effort he gave a gold coin to the driver. Unfortunately, he gambled away all the savings and a car on top on his loss, so, the baron had to leave only in his trousers, and the driver had to lend him his hard-earned gold coin so that they could take the train home. Of course, Codelli soon bought a new stronger Gottlieb Daimler's car. In 1903 in Nice in France he patented small heating and cooling apparatus, while preparing for a long journey. In a special container, the food was first frozen and then heated to the desired temperature before use. Of course, he could not advise users how to wisely save their money which he spent in Nice.

In 1906, Codelli developed a rotary explosive engine, the predecessor of a half-century later engine of the Nazis' fan Felix Wankel (1902 Lahr-1988 Heidelberg) designed after Codelli passed away. With improvements to the car, Codelli paved the way for inventors of modern car drives, among them Andrej Detela of the Jožef Stefan Institute.

The aeronaut Kraškovič soon enough welcomed his descendants among Slovenes. Among the most expensive physical devices at the gymnasium in Koper, in 1867, a rubber balloon was purchased with a pipe made of brass, which was probably intended for exploring gases. They bought it for 58 florins or 4.5 DM. In 1904/05, Maks Samec the Younger (* June 27, 1881; † June 1, 1964) began to fly with balloons for research purposes as well. On 24th of May 1908, at 11:55, he rose to the double balloon, which was administered by Ludwig's son dr. Arthur Boltzmann (* 1881; † 1952). The fellow Samec checked how the luminosity was increasing with height. In 1910, Codelli designed an airship which was a kilometer long, 100 meters in diameter. The imposing balloon was designed for the transport of 20 000 passengers at 160 km/h. Its volume of 1.25 million m³ would be eleven times smaller than a balloon with a radius of 240 m. The lift would exceed the

weight of a steel frame of less than a millimeter thick if Codelli exhausted the air from its ship to achieve the vacuum. During the exploration of balloon flights, the Ljubljana baron Codelli was able to identify the advantages of their size and on five typewritten pages he designed a huge steel balloon Dreadnought under the direction of Ober lieutenant Wallach in 1910.

In 1910, Codelli made a radio receiver for receiving accurate time signals. He donated the device to a professor at a higher school in Ljubljana Belar, who had his own seismic observatory in the basement of the real school on Vegova Street, a later electrical engineering secondary school.

Codelli did not like the Nazis who closed his door to Telefunken. Unfortunately, without a big backing company, he could not claim his inventions on the US market.

The Slovenes are justifiably proud of Codelli's contribution to modern technology. On important anniversaries, they are preparing numerous celebrations to draw attention to Codelli's achievements in vacuum technology, early television and automotive. An interesting picture of Codelli's early television might resurface anytime soon by pointing out that Codelli's scanning along the spiral is also interesting for the modern industry.

Codelli's opposition to the militaristic Nazi regime in Germany likely caused the interruption of his cooperation with Telefunken. After the Second World War Codelli's Turn by Ljubljanica river manor was nationalized. Codelli cautiously retreated to Switzerland before the end of the war. He knew very well where the trouble was and went to Switzerland in time to find his last rest. On 26 April 1954 he died in Port Roncas (Porto Ronco) near Ascona, where he was also buried.

In December 1995, a memorial plaque was unveiled at former A. Codelli's Manor-Castle in Kodeljevo part of Ljubljana. Codelli's achievements have been celebrated. The car enthusiasts provided a memorial plaque in front of his former castle. A memorial plaque was put at his former Manor Castle on Kodeljevo, which presents to the passers-by all about the first motorist in that part of Europe.

27.6.16 Slovenian Television before and After World War II

Codelli's spiral scan was never used on a larger scale and may still be waiting for its innovator. The development of television technique was booming after the Second World War. The Slovenians were well prepared for it. In 1937, a simple experiment with television was made in the first natural science circle in Slovenia at the 1st National Real Grammar School in Ljubljana. Eighth grade students Drago Leskovšek and the descendant of local noble family R. Švajgar made a cathode ray vacuum tube from the Erlenmeyer flask about 30 cm in length. On the bottom they applied ZnO. In the workshop of Arnold Zupančič, they brought electrodes into a container and to some extent sucked out the air without reaching a particularly high vacuum. During their demonstration, they used the Nipkow's disc of their own production and received a lot of approval from the audience, among which were the later leading Slovenian scientists including Ivan Kuščer (Figure 27-24).



Figure 27-24: Invitation to Rasto Švajgar's lecture on television in 1937.

The development of television technique after the Second World War in Slovenia, also in Yugoslavia, was connected with the activity of the Institute (later Industries) for electric wires in Ljubljana, which was officially established in the beginning of 1948. Initially, it was run by German experts,

and among others, by my friend Albin Wedam, the organizational and technical director of the TV-lab since the summer of 1949 or 1950. When Wedam authored his very last book in my cooperation he was facing his death very bravely while he narrated: "If they did not save François Mitterrand with the same type of cancer I have, they will not save me either. In the meanwhile, I think that there is an error in your part of our book where you published Marconi's noble title of marquis with capital letter which therefore sounds like it was his Christian name!" The pedantic scientist until his very end!

Wedam and his collaborators bought a super-orthicon from RCA and introduced the 625-line system of the German Swiss former ETH student Walter Gerber (* 1902 Bern; † 1986) invented in 1950, otherwise also designed in the Soviet Union. At the exhibition in the TVD Partizan hall on Tabor in Ljubljana Wedam and his assistants improvised a small TV studio with a super orthicon as the only recording camera in 1953. During the international exhibition of electronics in Ljubljana, Slovenian television program began to be broadcasted from the transmitter at the Economic Exhibition Center (Gospodarsko Razstavišče) and at Ljubljana castle in August 1956.

28 Major Industrial Uses of Vacuum Technologies - Ion Implantation

28.1 Rutherford's Discovery of Ion Implantation for Transistor

28.1.1 Introduction

The ion implantation belongs to plasma technologies. It enables the controlled installation of impurities in the substrate by electrically accelerating the selected ions. With the acceleration voltage from a few kilovolts to several hundred kilovolts, we change the energy of the implantation and the depth of the implantation. The current in the form of pulses determines the given charge and with it the number of implanted ions (the dose). The doses extend up to $10^{16} \text{ cm}^{-2} \text{ s}^{-1}$ and can be controlled during the procedure.

The essential components of the implanter are the ion source, the mass separator and the deflection mechanism with the target. The ion implantation takes precedence over diffusion processes because it does not pollute the environment, it is useful at a substantially lower substrate temperature (from 20°C to 200°C), and the mass separator allows implantation of the ions of a single element.

Besides the high costs, the defects in the process is undesirable radiant damage, which alters the electrical properties of the substrate and can be partially eliminated by subsequent heating to high temperatures by thermal annealing. Doping in deeper depths is less successful than in thin films below the surface. During implantation and afterwards, the doped ions penetrate deeper than expected due to diffusion and other phenomena.³⁰⁴¹

Ion implantation enabled the development of semiconductor technology in which the micrometer distances from the 1960s were sharply reduced in the new millennium. Although new surface doping technologies are also being developed to compensate for individual stages of semiconductor processing, ion implantation still

has a future. Today, it is also used outside the industry of integrated circuits, where the total financial share of plasma technologies in the production of integrated circuits is about 30%.

The development of ion implantation is particularly interesting, since it has witnessed unusually long delay from its "invention" until the first technological use four decades later. That delay in the 20th century is comparable only to the Einstein theory of stimulated radiation from 1916 and 1917, which also waited four decades for the first masers and lasers. However, Einstein published only a theory and not a useful invention like Rutherford did with his ion implantation. Certainly, Tesla's coil is waiting for its greater technological uses besides vacuum system leak detectors already for 130 years.

28.1.2 Rutherford's Era

During almost nine years before his premature death Maxwell was employed as the first professor of experimental physics and director of Cavendish laboratories of the University of Cambridge. His successors John Rayleigh, JJ Thomson and Rutherford developed those laboratories into the most important center of particle-dynamic tradition.

Helmholtz, like Kelvin and many others of their over-proud generation, promoted the funny thought that the main physical discoveries are already completed. So, they expected just more precise experimental results from their younger physicists of new generations. Such funny idea may have occurred in Helmholtz's age of vanity, but it was soon totally out of tune, because the new X-rays, radioactivity and quantum theory emerged immediately on their ways to hitherto unknown. The oversimplification of Helmholtz and Kelvin provoked the reaction of new rebel generation of Kiwi British immigrant Rutherford, as it always happens in such cases.

As a leading experimental researcher of dynamics of particles, Rutherford in Cavendish laboratories again played Galilean role of Damocles sword, or of Occam's razor. His opinion was decisive for quarrels between theorists on the eve of a new revolution in physics. Rutherford's times were clearly different, so there was no talk about the process of Galileo as it sadly happened in 1633:

³⁰⁴¹ Ryssel, Ruge, 1986, 1–2; Dresselhaus, Kalish, 1992, 31.

there was no church strong enough to make it happen. Almost three centuries after Galileo's misfortune the tall Kiwi native Rutherford was even promoted to the rank of first Baron of Nelson.

Galileo demonstrated his modernized attempts for innovations by experimenting mainly because he run out of any decisive logical arguments against peripatetic Aristotelians, but in Rutherford's times the experimental evidence was considered just as good or even better than theory. Rutherford, of course, mostly carried out real experiments and not the thought experiments of Galileo's, Bohr's or Einstein's preferences.

The supposed uselessness of their own theories described by famous mathematician Godfrey Harold Hardy and others in Rutherford's Cambridge was their great pride. Similarly, on the eve of Nazis' takeover in 1933, Hardy's five years younger Cambridge colleague Rutherford ensured everybody that nuclear energy will never be ready for any release; this was one of his rare scientific misleads, as Fermi showed nine years later when Rutherford was no longer in this world to object.

28.1.3 Electrified Particles in Solid Matter: "Cathode Rays" of Helmholtz Pupils

The Germans published the first studies of the transfer of charged particles through a solid substance. In 1882, Goldstein in Berlin proved that the "cathode rays" are diffusely reflected back during their passage through a lightly thin layer of metal. Nine years later, Hertz in Bonn continued to explore the scattering of "cathode rays". He noticed that the metal was more penetrable for "cathode rays" than for the light. The "cathode ray" could have penetrated a thin layer of metal, which previously known rays could not. He covered a part of the plate made of glass enriched with uranium compounds with a thin layer of gold while he covered the other part with a mica. He placed the glass plate in the cathode ray tube so that the side coated with gold was facing the cathode was. He observed luminescence on a part of the glass covered with gold, but not on other part covered with a mica. Two or three layers of golden leaves did not prevent the luminescence. The cathode rays also penetrated through the leaves of silver, aluminium, lead alloys with gold, silver, zinc or copper. The layers of copper, silver or platinum,

sputtered in a vacuum after discharge also did not stop the cathode rays.³⁰⁴²

After Hertz's death, his assistant Lenard continued his measurements of the reach and scattering of "cathode rays" in solid substances. Lenard used 2.65 mm thick aluminium sheets and studied gold, silver, copper, paper, glass and mica. For all measurements, the absorption of "cathode rays" was approximately proportional to the density of the substance. In 1898, Lenard passed the cathode rays through an aluminium window with a thickness of 3 mm and a diameter of 1.8 mm at a pressure of 30 mPa, thus observing the penetration of charged particles through a solid.³⁰⁴³

During the experiments with "cathode rays" outside the "Lenard's" cathode ray tube, after passing through thin metal sheets, many important phenomena were discovered within a few years, among them X-rays in 1895 and soon afterwards an electron was proclaimed after experimenting with the similar tools. By the middle of the 20th century, the researchers were mainly interested in the properties of missiles while they cared much less about the changes caused by their flight or by their implantation in the target. The exception was Lenard himself; his exploring of the target, and not just missiles, may have been one of the reasons why the "cream" of discoveries of X-rays, electrons and photons was picked up by others, although Lenard was considered the most important connoisseur of "cathode rays."

28.1.4 Montreal and Paris: Ion Implantation Follows Absorption of α -rays (1905-1906)

The development of physics at the transition to the 20th century was marked by thoughts about the composition of the atom and the discovery of various rays and particles. Among numerous novelties, Rutherford chose rays α for his research path at the end of the 19th century. He published about them 50 out of total of his 130 most important works between 1895 and 1914.³⁰⁴⁴ In 1905 and 1906 in Montreal, he studied the reduction of the rate of light passing through the

³⁰⁴² Hertz, 1895, 355; Frisch, 1972, 55; Laue, 1969, 310–311; Anderson, 1968, 48–49.

³⁰⁴³ Lenard, 1905, 369, 378, 386, 391, 558–559.

³⁰⁴⁴ Vjalcev, 1981, 218–219.

substance. After 1909, he proved in Manchester that the α particles are helium ions. Between 1909 and 1914, he experimented to confirm the model of the atom with a small "center charge", which he called "the nucleus" a year or two after his discovery. Rutherford's description of the absorption of α -rays was opposed by Becquerel and by J.J. Thomson's model of atom. Both opponents were awarded the Nobel Prize in Physics, and Rutherford received his Nobel Prize in Chemistry.

The "discovery" of ion implantation occurred during a dispute between researchers in Paris and Montreal about the nature of the α -rays. In 1898, Rutherford observed the absorption of rays from uranium in aluminium sheets of various thicknesses in his first independent investigations after arriving in Montreal. He found that absorption dropped significantly at thicknesses of several hundredths of a millimeter and then again at thicknesses of a few inches. He therefore assumed that he observed the rays of two species. Immediately after the new year, he announced that he was dealing with the rays α and with the rays β . The later should be like X-rays, while the first resembled their secondary, softer radiation. The assumption of the wave nature of radioactive rays was perhaps unusual in view of the strong tradition of particle defenders in Cavendish.

In March 1899 in Paris, Becquerel accepted Rutherford's observation; but Rutherford's explanations only reigned for a year until the Curie spouses separated both types of radiation from a stronger polonium with a magnet. Until 1902/1903 most researchers were convinced that the β -rays were electrons. In 1900, they announced that the rays α did not spread after the transition through metal, which in the following years sparked a lively discussion between Parisian and Montreal erudite. The Curie couple, together with Becquerel, separated both types of rays by deflection in magnetic field, and Rutherford distinguished among them by their different absorption in the metallic sheets. The approaches of the Parisian literati and Kiwi-English-Canadian researchers in predominantly French Montreal were again directly opposite. They repeated a couple of years older antagonism when J. J. Thomson "discovered" the nature of "cathode rays" with their deflection in the magnetic field which Villard in Paris

considered as a secondary property while Villard himself mostly explored their chemical effects.³⁰⁴⁵

Rutherford's friend, former J. J. Thomson's student Bragg of the University of Adelaide in Australia, entered the world of experimental research in 1904 with the theory of absorption of α -rays and the description of their ionization in the air. In Bragg's letter of 31 August 1904, Rutherford read for the first time a description of an "open" atom with a lot of empty space.³⁰⁴⁶ Thus, Bragg encouraged Rutherford's research of the penetration of the rays α and the nuclear model of the atom.

Ernest Rutherford was born in New Zealand in a family of collier and his wife a former teacher. As a 11-year-old boy, he learned science from book *Outlines of Physics of Stewart* whose chair in Manchester he took over a quarter of a century later. Rutherford studied at Canterbury University, founded in Christchurch in 1873. After the master's degree in 1893, he was not particularly successful as a secondary school teacher. He made up a detector to catch radio waves at distance of 3 km, which was at that time a record achievement. His experiments opened the way to his research fellowship of the Royal Commission for the Exhibition of 1851, which was first offered to a year older Rutherford's colleague chemist James The Scotsman Maclaurin (1864 Unst the northernmost of the Shetland islands in Scotland-1939 Wellington) of Auckland University College who declined it for family reasons, in fact because he wished to retain his position in Auckland. Thus, in 1895, Rutherford went to Cambridge, where they only then begin to award research degrees like universities in Berlin, Glasgow and elsewhere. On his way he stopped to see Bragg in Australia. Rutherford became the first research assistant to J. J. Thomson. Thomson correctly assessed the high potential of his new colleague and already in 1896 invited him to participate in the BAAS meeting on the translation of electricity in gases. Thomson and Rutherford were very different. Thomson studied the β -rays with the greatest successes, while Rutherford studied the α -rays³⁰⁴⁷ for nearly four decades. Both had a very personal relationship with their investigated "corpuscles", which was preserved

³⁰⁴⁵ Lelong., 1997, 102.

³⁰⁴⁶ Rutherford, 1906, 135, 143; Danin, 1983, 40.

³⁰⁴⁷ Kedrov, 1980, 20; Badash, 1987, 361.

in many funny stories. However, colleagues preferred to see that Thomson did not use laboratory equipment. His clumsiness was already quite legendary, almost comparable to that of Pauli, who was reportedly destroying experiments at the distance from several meters.³⁰⁴⁸ Rutherford was a skillful man. Later as head of the laboratory, visited researchers several times a day and has reprimanded them for inefficiency and slowness. He had twice briefly met a plumber whom Rutherford mistakenly took for one of his "boys". The plumber was upset and refused to finish his work.³⁰⁴⁹



Ernest Rutherford (* 1871; † 1937)

In September 1898 and June 1907, Rutherford went to Canada as a professor of McGill University of Montreal and head of a laboratory there, which was financially supported by Sir William Christopher Macdonald's (1831-1917 Montreal) tobacco industry founded in 1858. In 1899 Rutherford discovered a new element radium to study its rays β and α . For radioactive noble gases, he used the term "emanation" from Robert Boyle's vocabulary because he did not know whether he was dealing with gases, steams, or particles. In 1905 he became Fellow of the RS. By 1919, he taught at the University of Victoria in Manchester, which developed from Owens College, established in 1846. Physics was once taught there by Dalton and Joule, who was Dalton's student from 1835 to April 1837. From 1870 until his death Stewart lectured there along with the

famous spectroscopist Henry Roscoe and Schuster. Reynolds taught technic in Manchester there between 1868 and 1905. The college developed a physical laboratory in 1900 and became an independent university three years later.³⁰⁵⁰

In 1908, Rutherford received the Nobel Prize in Chemistry for his exploration of radioactivity, which began to undermine the ancient idea of the indivisibility of atoms. In a party after the Nobel Prize-winning lecture, Rutherford declared that "I had already dealt with many different conversions with different periods, but among all the fastest is my own instant conversion from physicist to chemist." On the news about the Nobel Prize, his mother, one of the first female teachers in New Zealand, congratulated him in her letter and expressed her hope that he would come home to help dig potatoes anyway. She therefore quickly forgot that her son had shown her "the last potato that he dug" years ago when she told him about his receipt of a research fellowship of the Royal Commission for the Exhibition of 1851 during their work in the garden.³⁰⁵¹

In 1914, Rutherford discovered the proton and he was knighted. In 1917 he studied ultrasound for the needs of the army, along with his former colleague in Cavendish Langevin whose previous student was a later inventor of the television Zworykin at Collège de France. In 1919, Rutherford succeeded Thomson as the head of Cavendish. In 1925, he became president of the RI, and in 1931 he was named Lord Nelson after a town in New Zealand where he attended secondary school. Rutherford's book Radioactivity repeatedly received new chapters after the first printing of 1904 and influenced a whole generation of experimental physicists. Nearly a dozen Rutherford's pupils and colleagues received their Nobel Prizes, among them many foreigners including Germans, Russians and the inhabitants of the Habsburg Monarchy.

In July 1905, Rutherford published measurements of the decrease in the rate of rays α during their passage through the substance (Figure 28-1). When their initial velocity on their way through the aluminium leaves dropped to around 60%, they could no longer influence the photo plate or ionize

³⁰⁴⁸ Weinberg, 1986, 85, 143.

³⁰⁴⁹ Kapitsa, 1981, 298–299.

³⁰⁵⁰ Badash, 1987, 361; Kedrov, 1980, 46.

³⁰⁵¹ Staroseljskaja-Nikitina, 1967, 120, 123; Kedrov, 1980, 12.

the gas. The results supported Bragg's theory of absorption and the conclusion that "radium emits four types of rays α with different penetrating powers"; they were subsequently explained by the fine structure of the spectrum of rays α , or by the radiation of the ^{226}Ra daughter nuclide of the radioactive decay chain.³⁰⁵²

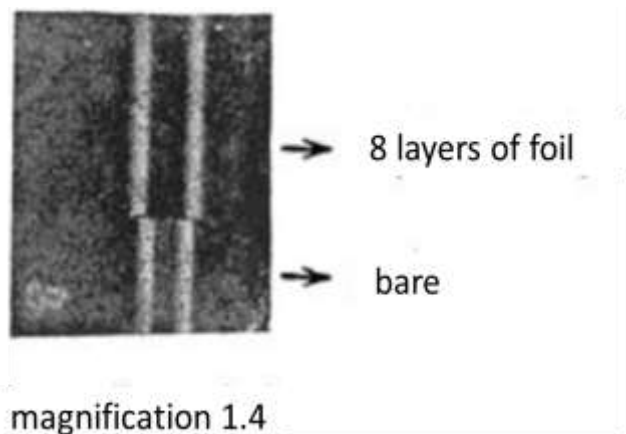

Figure 28-1: Rutherford's photo of α -particles taken in a vacuum, after half of them reached the photo plate through eight aluminium leaves, while the other half felt there on that same photo plate without intermediate obstacles.³⁰⁵³

Rutherford's results contradicted the research of H. Becquerel, who measured the magnetic deflections of α rays at a normal pressure recorded on the photographic plate in 1903. He found that the twice stronger field does not move the traces of rays α in the photo. Becquerel therefore claimed that the source is homogeneous and radiates only the α rays of the same velocities. The radius of deflection was increasing with distance from the source. H. Becquerel explained that fact with the assumption that the mass of rays α increases with the distance due to the "added particles from the air." Similar ideas were published at the turn of the century by Curie, Crookes, Kelvin and Perrin,³⁰⁵⁴ but from a modern point of view they sound quite unusual which enabled Rutherford to effectively reject them. Probably, Becquerel had in mind a kind of cosmical radiation which was researched in more details only by Victor Franz Hess's (1883 Waldstein castle in Styrian Peggau-1964 Mount Vernon suburb of New York) balloons in 1911-1913.

³⁰⁵² Rutherford, 1906, 11: 166, 171; Rutherford, 1906, 12: 141.

³⁰⁵³ Rutherford, 1906, fig. 1 of plate IV printed after page 192

³⁰⁵⁴ Weinberg, 1986, 168.

Antoine Henri Becquerel was the son of the president of the Parisian Academy as the third generation of the famous family of physicists and chemists. In 1874 he completed the Polytechnic of Paris. He was appointed a lecturer there two years later, and he became a professor in 1895. In 1892, he succeeded his father's job at Muséum d'Histoire Naturelle in Paris, along with excellent preparations of uranium compounds stained in glass, which were waiting for their researcher. On March 1, 1896, he discovered the rays, which many, including J. J. Thomson, called "Becquerel's rays". At first, Becquerel thought he was observing luminescence in the X-ray range, supported by Thomson's research in 1896. In January 1899 Rutherford declared them as new types of rays α and β .³⁰⁵⁵ Becquerel's discovery was later called radioactivity, and in 1903 he received the Nobel Prize in Physics together with the Curie spouses. In 1900 he measured the e/m ratio of the β rays and found that it is the same as in the three-year-old Thomson's measurements of "cathode rays". On 16 November 1908 he became the permanent secretary of the Parisian Academy. On 11. 9. 1905, H. Becquerel repeated Rutherford's measurements of absorption of rays after their transition through the aluminium sheets. In contrast to Rutherford, he has measured at atmospheric pressure and not in a vacuum and he included a magnetic field. Like Rutherford, he used barriers from aluminium leaves down to a thickness of 0.034 mm, in a distance of a few millimeters from the photographic plate. Photographs of the α -rays after passing through the aluminium sheets could not be distinguished separated from others to which the rays approached only through the air. Therefore, he considered that Rutherford noticed the absorption of rays due to the specificity of the radium which he used. Becquerel easily afforded this sort of critique because of course he had much better radium and its salts in his disposal. Rutherford only used radium from 1 mg sample of his pure RaCl_2 , which the Parisian Société Centrale des Produits Chimiques donated to him. Becquerel again rejected Bragg's and Rutherford's theory of the absorption of α -rays in matter. The Parisian Becquerel like Nollet a century and a half before him refused the strange ideas from the wild new worlds of America, Australia and New Zealand under the pens of Franklin, Bragg and

³⁰⁵⁵ Feffer, 1989, 18-20.

Rutherford, but ultimately failed. Becquerel thought that all rays had the same velocity that does not change when they penetrate through the substance, while the mass of the rays α "increases in some way while traveling through the air."³⁰⁵⁶ The conservation of the mass was put into question, which was at the same time solved by Einstein with his theory of relativity, but only for much faster particles. It was a turning-point full of fascinating novelties when the impossible theories became probable, and the unusual experiments were decisive.

On 15. 11. 1905 Rutherford again reported from Montreal about his bombarding of the aluminium leaf with the α -particles. Of course, he did not dare to challenge the measurements of his more famous Parisian colleague and Nobel laureate. Therefore, he preferred to acknowledge their validity and explained the results boldly in favor of his and Bragg's theory. He used the aluminium sheets of a thickness of $3.1 \mu\text{m}$ and a constant magnetic field, which he periodically turned. By adding aluminium sheets, he increased the distance between the lines on the half of the photographic plate and the lines on the other half of the panel, which the rays reached without obstacles. With thirteen aluminium sheets, he reduced the beam speed to 62% and disabled their record on the photo plate.

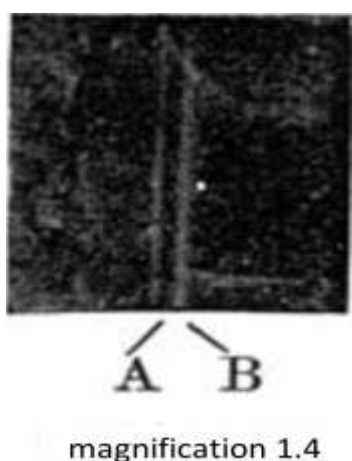

Figure 28-2: Rutherford's α rays from pure RaCl_2 on a 4 cm distant photo plate in a vacuum.³⁰⁵⁷ He used a weak magnetic field to deflect the β rays, but that field did not deflect α rays.

³⁰⁵⁶ Rutherford, 1906, 168–169.

³⁰⁵⁷ Rutherford, 1906, fig. 2 of plate IV printed after page 192.

In next series of his measurements, Rutherford used a measuring device like Becquerel's. He split his photo plate into two halves with a mica screen. He covered one half with eight aluminium sheets. A higher diffraction of the rays α after passage through the aluminium sheet was clearly visible in the photograph, although Rutherford had some problems in excessive acceleration voltages due to the sputtering of the black layer from the copper conductor, which slightly reduced the beam velocity.

Rutherford recorded the α -rays of pure RaCl_2 at a 4 cm distant photo plate in a vacuum. He used a weak magnetic field that deflected the rays β , but not the rays α (Figure 28-2). His magnetic field did not change by more than 0.5% during the experiment. After passing through the aluminium sheets, the rays recorded themselves on the photo with 1.9 times wider lines than rays flying through the vacuum. The broadening of the lines already supported Rutherford's greatest ideas of repulsion from a large "center charge" of atoms. The result of the experiment was supported by the description of the rays α as particles with the same e/m ratios but travelling by different speeds, which enabled their separation in the magnetic field. The measurements were, of course, disturbed by the accompanying β and γ rays with their own contribution to the blackening of the photographic plate. Rutherford explained Becquerel's observations with his and Bragg's theory of absorption. After the passage through the aluminium barrier, only the fastest rays, which are most deflected in the magnetic field, should come to the photographic plate. The same rays were deflected the most without passing through the aluminium barrier. The lines on both halves of the photographic plate, separated by the mica screen, were therefore matched. The finding was valid both in the flight through air and when passing through the vacuum to the other half of the plate. Due to the reduced speed, the inner edge of the trace on photographic plate was moved outwardly. With wide Becquerel's beam, it was hard to notice the shift. Additionally, it was blurred by the scattering of rays on air molecules because Becquerel did not measure in a vacuum. The bearded Parisian Becquerel lost his first game defeated by the Kiwi mustached Rutherford coming out from nowhere of the Oceanian new world.

To investigate Becquerel's claim that the radius of curvature of paths of α rays increases with distance from the source, Rutherford additionally measured it at normal pressure (Figure 28-3). After 40 minutes of illumination of the photographic plate, the metal barrier was moved to the other half of the panel and they exhausted the measuring vessel. On the same photo, the trace of rays after passing through a vacuum was plotted with two narrower lines. After the same long flight through the air, the lines were more deflected and wider. A slight shift between the two groups of lines occurred due to the random movement of the plate during the shifting of metal obstacles in the middle of the experiment, probably one of the participants made a careless mistake. At the end of his paper, Rutherford announced similar measurements of scattering on solid substances, which indeed followed.

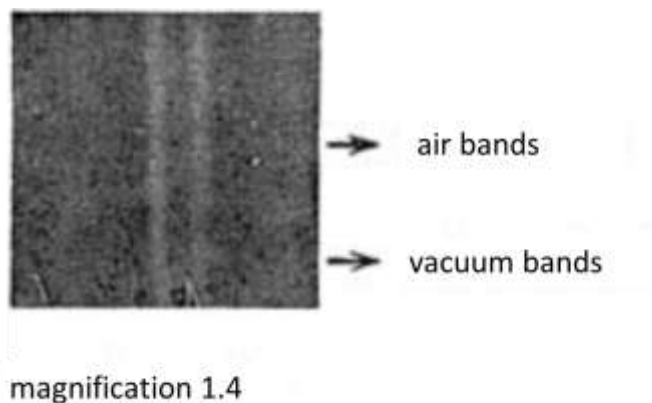

Figure 28-3: Rutherford's photos of α rays at normal pressure in a homogeneous magnetic field. Half of the photographic plate catches the rays after passing through the eight aluminium leaves, while the other half, separated by a mica screen, takes the rays that approach the plate without intermediate obstacles.³⁰⁵⁸

The result contradicted Becquerel's claim about the reduction of the e/m ratio with a distance from the source. This, according to Rutherford, was the result of Becquerel's incorrect assumption about the homogeneity of the α -rays. The radius of curvature of the α -beam at the outer edge of the photographic trace has been rising with distance from the source because only the rays with higher initial velocities approached larger distances. On the inner edge, the opposite was true, since the speed of the fastest rays falls with the distance from the source. The rise in the radius of curvature

³⁰⁵⁸ Rutherford, January-June 1906, fig. 3 of plate IV printed after page 192.

on the outer edge prevails over the reduction in the radius of curvature at the inner edge of the image. Therefore, the radius of curvature increases, as Becquerel correctly observed.³⁰⁵⁹

His disputes against Becquerel forced Rutherford's high-vacuum measurements that avoided the side effects of the substance. If he had a poorer radioactive pattern than Parisian rivals, he could at least put it in a better vacuum of a container. In the following months, he supplemented his evidence of a constant e/m ratio of α -rays. For rays β , such ratio was measured nearly thirty years earlier by Thomson and after him by Becquerel. Rutherford measured the ratio between the momentum and the electric charge, and between the kinetic energy and the electric charge of α -ray after their passing through a vacuum towards a mica screen. When an aluminium sheet was added to the mice, it absorbed almost twice as much. In all measurements, Rutherford received roughly the same e/m ratio. Although the results seemed too high, he proved with them that he was always observing the same particles. Rutherford's finding of the same e/m ratio for all rays α was the introduction in three years later subsequent proof of their identity with helium ions. Rutherford wished to obtain his own particle like his mentor J.J. Thomson obtained his corpuscle alias electron few years earlier. Becquerel preferred one sole type of radiations which he discovered, but Rutherford was not willing to abandon his hardly received toys although his particles later proved to be "only" the ions of helium and not something completely new as he hoped in secret. Without the kiwi Rutherford's premature death, his WW2 features as Manhattan project boss might have been interesting as he opposed the military uses of airplanes but worked on military detections of enemy's submarines in WW1 anyway.

On 14/06/1906 in Montreal Rutherford reported on the burning of aluminium leaf with α -rays. He also described the radium conductor in the triangular groove of the bronze cylinder, attached to the base plate (Figure 28-4). On one side of the roller he fixed the vertical stick. Two mobile stands were connected through a notch in the middle. The lower one had a slit, and the upper one had a small photographic plate. The distance between the stands could be changed by screws. The gauge was

³⁰⁵⁹ Rutherford, 1906, 170–176.

surrounded by a bronze-top closed cylinder whose lower side was connected to the edge of the wheel inserted in the base plate. He sealed his wheel with the ointment used for drills, so that the container could be quickly discharged with Fleuss' pump.

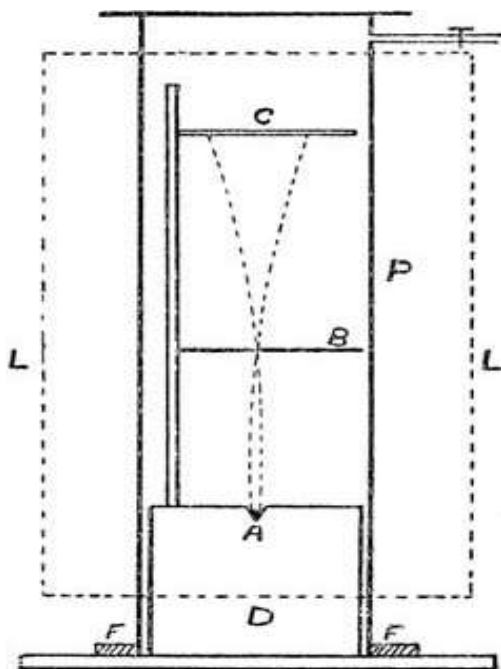

Figure 28-4: Rutherford's measuring device, compiled in Canada in 1906³⁰⁶⁰

Thus, he avoided the flattering of his bronze container when sealing it against the bronze plate and saved time and work, which was very important in experiments with the magnetic beam deflection of α -rays from the radium. He put it all together in a wooden frame between the pole of a large electromagnet with a field parallel to the rays which was practically identical along the path of rays. The area between the radium as the source and the photographic plate was divided into two halves by vertical plates of mica. The first was uncovered or covered with a screen that absorbed as many α -rays as 3.5 cm of air. The other was covered with a different number of aluminium sheets. Thus, on the photographic plate, he obtained two groups of lines with centers, spaced apart for the dual deflection of the ray α of the rectangle due to the influence of the magnetic field. The distance between the deflected lines was inversely proportional to the speed of the rays after passing through the obstacle (Figure 28-5).³⁰⁶¹

³⁰⁶⁰ Rutherford, 1906, 135.

³⁰⁶¹ Rutherford, 1906, 358–359, 135–136.

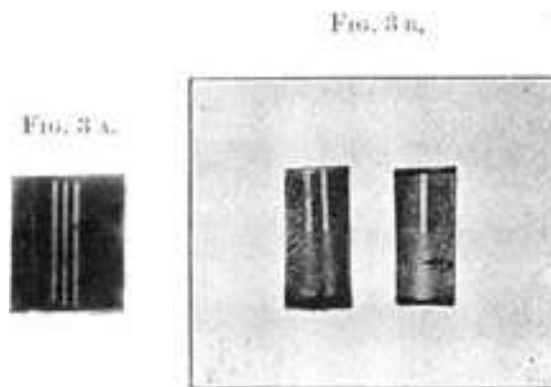

Figure 28-5: Rutherford's α -beam after passing through the mica from 1906³⁰⁶²

Rutherford made over hundred photographs showing the effect of the electric and magnetic fields on the α -rays. Initially, photos were observed through a microscope, but that kind of work severely tired the eyes of researchers. That's why Rutherford and his helpers preferred to project a 20 to 40-fold enlarged image on the screen with a lamp resembling their Chinese predecessors' watching pinhole image through their camera obscura two millennia and a half earlier. Rutherford used aluminium leaves that stopped as many α rays as about 5 mm wide layer of air. The distances between the radioactive source and the slit and between the slit and the photo plate were 2 cm, while in their other experiments they shortened them to 0.5 cm and 1.5 cm. In a row, they changed their obstacles that consisted of up to fourteen aluminium sheets. If two more layers of more permeable "Dutch" metals³⁰⁶³ were added to them, they completely absorbed α rays, just like 7.06 cm of air according to Bragg's exponential law.³⁰⁶⁴

At the beginning of the 20th century, absorption of α -rays in matter was studied mainly in Cavendish, Manchester and Vienna. In 1909, T. S. Taylor of Sloane labs in Yale University measured that the absorption of α -rays in different substances more changes with their speed at greater beam velocity and the greater atomic mass of the substance. He compared the absorption coefficients in hydrogen, aluminium, lead, gold and tin with air. Later in 1912 T. S. Taylor researched on Physics Buildings in Urbana Illinois and collaborated with Marsden in 1913 while Rutherford's golf partner Geoffrey Ingram Taylor (1886 London-1975 Cambridge)

³⁰⁶² Rutherford, July-December 1906, figures 3a and 3b of plate Ii printed the text.

³⁰⁶³ Alloy of copper and zinc.

³⁰⁶⁴ Rutherford, 1906, 138, 144.

collaborated in Cavendish where in 1910 JJ. Thomson investigated the absorption of α -rays in thin films, and two years later the ionization of matter along the track of the charged particle was studied. Bragg's model of the absorption of α rays in the air was supported by Geiger's measurements of polonium α rays, as well as by Taylor, Francis Lee Friedman (1918 New York-1963 Boston) and Boltzmann's son-in-law L. Flamm in Vienna.³⁰⁶⁵

28.1.5 Rutherford in Manchester: Implanter and Identification of α - rays with He^{++} (1908-1909)

To supplement his small amount of radium of the Parisian Societ e Centrale des Produits Chimique, Rutherford later used about 400 mg of radioactive material derived from uranium, which he loaned from the Viennese Academy in January 1908. Similarly, the people of Vienna previously supplied several tons of Czech uranium ore to the Curie spouses in Paris. In fair exchange of those times, the Viennese got some western photographs for studies in their labs.

In August 1908, in addition to photographs Rutherford in his laboratory used an improved spintariscope,³⁰⁶⁶ which Crookes described for the first time on 19 March 1903. Through the microscope they observed the scintillations of the α rays induced on the luminescent ZnS after their passage through the substance. Geiger and Rutherford compiled a particle counter of α particles, which, after subsequent improvements, was named Geiger-M uller. As early as 1893, the Scotsman C. T. Wilson began to develop a cloud chamber named after him which he rearranged to observe the α rays in Cavendish in 1911. Initially they used T opl er's pump, supplemented with graphite in the liquid air. Later, they acquired few Gaede's rotary mercury pumps, but it was difficult to get hold of them because many users in the lab were waiting in the row to get some pumping. Thus, Lenard in Heidelberg had better vacuum pumps than they could afford in Manchester prior to the First World War.³⁰⁶⁷

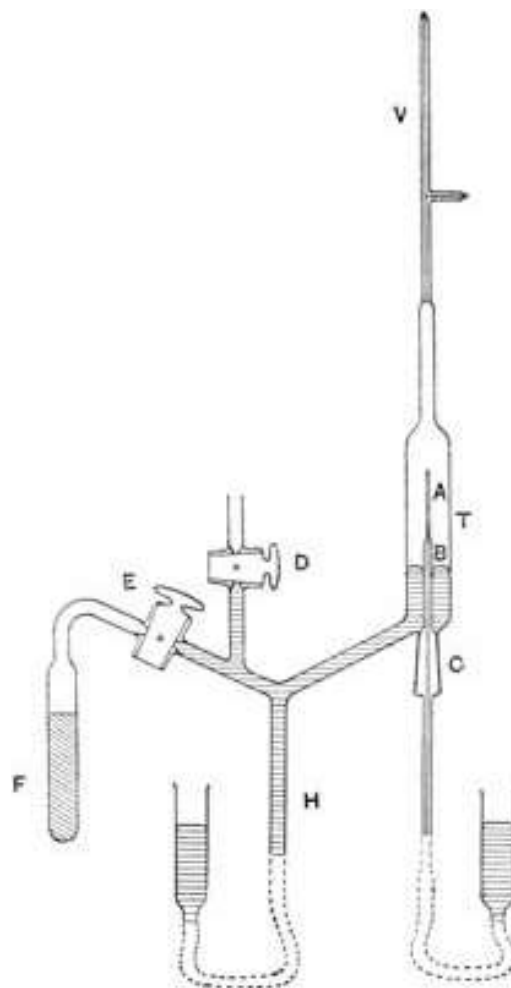

Figure 28-6: The first device for ion implantation according to Rutherford's and Royds' designs³⁰⁶⁸

Rutherford's first ion implantation device was no more complicated than a small glass tube with radioactive radon emitting α rays (Figure 28-6). On 13 November 1908, he described it together with Royds, who, as Geiger, learned all about spectroscopy in Manchester with Rutherford's predecessor, Schuster. They explored the nature of the α -rays in an experiment that Rutherford conceived already in Canada. About 140 mg of radium was cleaned and compressed with a mercury column in a thin glass tube, about a half centimeter long. The German glassblower Otto Baumbach (1882 Niederwilligen in Thuringia-1966 Alkington, UK) was able to produce glass containers with even thickness of less than 0.01 mm, which was strong enough to withstand mercury pressure. At the same time, it had enough thin walls to stop only as many α -rays as a 2 cm thick layer of air. Thus, most rays escaped from the container towards the luminescent ZnS screen, but at first only up to the distance of 3 cm. After an

³⁰⁶⁵ Geiger, 1910, 505.

³⁰⁶⁶ Spintariscope was the oldest radiation detector, consisting of a brass tube, a magnifying glass and a ZnS screen.

³⁰⁶⁷ Kedrov, 1980, 26, 47; Rutherford, 1906, 145-146;

Staroseljskaja-Nikitina, 1967, 130-131, 138-139; Robinson, 1963, 66, 74; Birks, 1963, 30 .

³⁰⁶⁸ Rutherford, 1909, Royds, 282.

hour, luminescence was observed at the distance of 5 cm, since α rays were at a higher speed, while those with lower velocities were mostly emitted within their half-life of 3 minutes. The glass receptacle touched the inner walls of a glass cylinder of 7.5 cm long with a diameter of 1.5 cm, emptied by the pump. They improved their vacuum by a tube full of charcoal cooled in the liquid air. After their flight through the thin wall of the inner glass container the α rays stopped in the walls of the outer glass vessel or on the surface of mercury.

If the α rays were ions of helium, they would gradually diffuse from glass and mercury back into the vacuum. They pushed the gases ensembled above the column of mercury into a vacuumed vessel and examined them there by a spectroscope. After two days, they noticed a characteristic yellow line of helium, after four days the additional green line appeared, and after six days, they observed all the main lines of the helium spectrum. Geiger helped some of those Rutherford and Roysds' experiments.³⁰⁶⁹

Rutherford's evidence of the identity of helium ions and α -rays has greatly increased his reputation, because he was supported by Dewar and other older British researchers because the matching between experiments and Rutherford's theoretical predictions is almost wonderful, which confirms the correctness of the theory of radioactive changes for which onset and development he has already done so much. "³⁰⁷⁰

28.1.6 Rutherford's "Center Charge" of Atoms and Scattering of α -rays on Metals (1909-1914)

Rutherford had already seen in Montreal that reflection produces diffuse images of α rays after passing through thin metal sheets. Even at his earliest studies of the scattering of the α rays, he assumed that "some of the α rays in passing through the mica have been deflected from their course through an angle of about (2°). It is possible that some were deflected through a considerably greater angle: but, if so, their photographic action was too weak to detect on the plate... change of direction of 2° in the direction of motion of some

of the α particles in passing through thickness of mica (0.003 cm.) would require over that distance an average transverse electric field of about 100 million volts per cm. Such a result brings out clearly the fact that the atoms of matter must be the seat of very intense electrical forces – a deduction in harmony with the electronic theory of matter."³⁰⁷¹ That claim was the outline of the subsequent Rutherford nuclear theory of atoms.

Already in May 1909 in Phil. Mag. Rutherford announced that he "knows what the atoms looked like".³⁰⁷² Many researchers, including Lebedev in 22. 1. 1887, Bragg, Nagaoka and Stoney, discussed the nuclear model before Rutherford. Many suggestions followed the discovery of the "electron": JJ Thomson and Larmor (1896), Perrin (1901) with subsequent additions of his compatriot H. Becquerel, Kelvin (1902), Lenard (1903) after half of a century older Dynamides, in the same year again JJ Thomson, and Stark (1907) who already used the idea of quanta. The popularity of the new model with empty space in bulk of the atom³⁰⁷³ was increasing due to the prevailing experiments with vacuum devices, the similarities with solar system and then authoritarian states circulating around their nuclear leaders.

In the spring of 1909 according to Rutherford's instructions, Marsden and Geiger observed a reflection of one of about 8,000 bombarding α rays from Ra-C'³⁰⁷⁴ when passing through a thin layer of platinum. On a gold leaf with thickness of 4 μm , which absorbed as much α rays as the 1.6 mm of air, on average, one of 20,000 α rays was deflected by more than the right angle. They also measured the percentage of reflected rays on the sheets of metals like lead, tin, silver, copper, iron and aluminium. The 20 Mg RaBr₂ tube was pumped out to a few mbar and closed with a mica window that absorbed only as many α rays as did 1 cm of air. The deflections greater than 90° were observed with the microscope as scintillations on the ZnS-screen. Except for lead, they confirmed Bragg's theory, according to which absorption on the atom is proportional to the square root of its mass. They measured the reflections on various numbers of thin golden sheets with reflectivity equal to 0.4 mm of air. They proved that they were not dealing

³⁰⁶⁹ Rutherford, Roysds, 1909, 282; Kapitsa, 1981, 280; Kedrov, 1980, 52–54; Birks, 1963, 32.

³⁰⁷⁰ Dewar, 1927, 2: 1013.

³⁰⁷¹ Rutherford, 1906, Phil. Mag. 12: 144–145.

³⁰⁷² Danin, 1983, 48.

³⁰⁷³ Vjlavec, 1981, 83–86; Badash, 1987, 364.

³⁰⁷⁴ Former term for modern ²¹⁴Po.

with a surface effect but with a bulk-related phenomenon.³⁰⁷⁵

James Arnold Crowther was professor of physics at Reading University southeast of Oxford between 1924 and 1946. From 1936 he was a secretary Physical Institute in London, and from 1946 he was its Vice-President.

The New Zealander born in England **Ernest Marsden** studied in Manchester until 1914. He then returned to New Zealand, where he was a professor in Wellington until 1922, and then worked in the Department of Scientific and Industrial Research until 1954, after 1947 as the president of the New Zealand RS.³⁰⁷⁶

Geiger reported to Rutherford about an unexpected discovery. Half an hour later, Rutherford announced his colleagues at Sunday lunch for the discovery of a "nuclear charge" in the atom. He bombastically described the result at one of his last lectures before his death "It was as if you fired a 15-inch shell (38-cm bullet) at a piece of silk paper and it came back and hit you." This was yet another of Rutherford's speeches which made history. In fact, he has been supporting the nuclear model for many years, but he has not been able to effectively prove it with experiments until then. On March 7, 1911, he described it to the Manchester Literary and Philosophical Society, where Dalton reported on the study of masses of "indivisible" atoms a century earlier.³⁰⁷⁷ Naturally, Dalton turned over in his grave several times, as Rutherford's powerful voice was announcing a new era where the ancient uncuttable atoms were suddenly cut up. The people were subjected to statistics like atoms even if they retained their private individual complex structures.

In his discussion of the dispersion of α rays and β rays, Rutherford did his best to provide some theoretical computations, although he was not known as a mathematician. He wished to disprove

³⁰⁷⁵ Rutherford, 1911, 669, 680–681; Geiger, Marsden, 1909, 495–500; Thomson, 1970, 61; Staroseljskaja-Nikitina, 1967, 140.

³⁰⁷⁶ Brown, 1997, 18, 21 and 133.

³⁰⁷⁷ Kedrov, 1980, 55–58; Thomson, 1970, 62; Danin, 1983, 37; Weinberg, 1986, 169, 178; Robinson, 1963, 68.

those claims. Next month, the discussion with "Rutherford's equation" was sent to Phil. Mag. He showed that atoms contain the center of a strong electric field. He first considered Thomson's theory of scattering of charged particles on a thin layer of "pudding-atom", in which the mass and charges of both signs were evenly distributed.



Figure 28-7: A page from Rutherford's laboratory logbook, where he sketched the composition of the atom³⁰⁷⁸

Crowther and Marsden experimental measurements of the scattering of rays on the aluminium supported Thomson's model in 1910. Marsden measured on slightly thicker layers. Crowther estimated that the number of electrons was approximately three times greater than the atomic number. From Geiger's and Marsden's measurements of the scattering of the α rays on alloys of platinum and gold it followed that these atoms have at the center about 100 basic charges, almost identical to their atomic mass. Rutherford considered that the same general laws govern the transmission of a beam of α -rays or β -rays through the substance which indicate that the atom has a central charge about the same as its atomic mass allegedly centered at a central point, at least for atoms more massive than aluminium. (Figure 28-7) He has not yet dared to determine the type of charge in the center of the atom. He referred to the

³⁰⁷⁸ Staroseljskaja-Nikitina, 1967, 141.

similarity of his assumptions with the "Saturn's" atom of Japanese Nagaoka, published at the Physico-Mathematical Society in Tokyo on December 5, 1903, few weeks before the outbreak of Russo-Japanese war. On 11 March 1911, WH Bragg informed Rutherford about Nagaoka, and nine days later Rutherford already wrote about it to Nagaoka.³⁰⁷⁹ Japan entered the world of science as a superpower, and the kiwi Rutherford recognized the Japanese as one of the first.

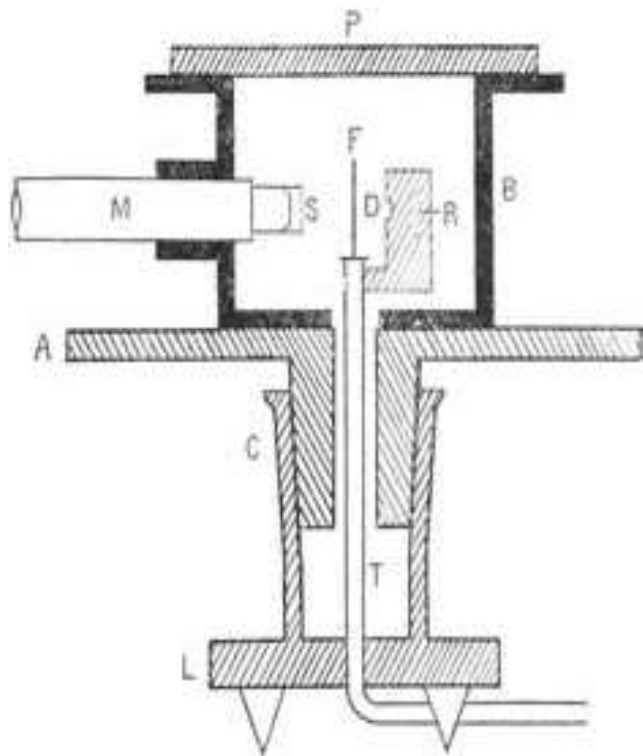

Figure 28-8: Geiger and Marsden's measuring equipment in 1913³⁰⁸⁰

John William Nicholson (* 1 November 1881, Darlington; † 3. 10. 1955) was a physicist, astrophysicist and mathematician. He was chairman of the X-ray Society, vice president of the London Physical Society, the secretary of British Mathematical Association in 1910-1920 and its president in 1920-1930.

Rutherford's colleagues and their experiments did not initially come to terms with the idea of the "center charge" of the atom, most of all not in J.J.

Thomson's Cavendish Laboratory.³⁰⁸¹ Rutherford attended the 1st Solvay Congress in Brussels at the end of October 1911, but nobody was interested in the nuclear model there. In 1912 Nicholson tried to describe it with quantum mechanics. In August, Bohr joined Rutherford's laboratory, where he even helped with the measurements. Bohr's model of atom no longer only described radioactivity;³⁰⁸² he established himself with a new generation of researchers and encouraged the development of quantum mechanics.

In 1912 C. G. Darwin supplemented Rutherford's scattering theory. He thus endorsed the predictions of his grandfather, CR Darwin, of the billions of years of development of species that Rutherford's theory of radioactivity had just explained.

Thomas D. Royds, like Rutherford (1895), Barkla (1899) and Chadwick (1913), received a research fellowship of the Royal Commission for the Exhibition of 1851, to enable his studies of physics in Manchester at Schuster and Rutherford's labs. On the initiative of Queen Victoria's husband, this most dignified scholarship for graduates of provincial universities in the amount of 150 pounds sterling was given out of a part of the income of the world exhibition in London in 1851. During the WW2, the solar physicist Royds led the observatory in Istanbul while lecturing even in Turkish language.

Next year, Geiger and Marsden continued the measurements by varying the angle of incidence and the speed of the rays (Figure 28-8). They first published the results at the Viennese Academy of Sciences, most of all to express their gratitude for the loaned radium. They used the same source as Rutherford and Royds did four years earlier. The radium was closed into lead to decrease the influence of β -rays. They measured on gold and silver sheets whose absorption was equal to 4.5 mm or 3 mm of air, while their vacuum was improved with graphite cooled in the liquid air. The scattering on thin sheets was proportional to their thickness. They also measured tin, copper, aluminium and charcoal in paraffin wax. The scattering on a 21 μm thick golden sheet at the

³⁰⁷⁹ Crowther. 1910. *Proc.Roy.Soc.* 84: 226; Rutherford, 1911, 686–688; Filonovič, 1990, 193.

³⁰⁸⁰ Geiger, 1913, 609.

³⁰⁸¹ Danin, 1983, 30–31, 50, 93; Filonovič, 1990, 189–190.

³⁰⁸² Badash, 1987, 365.

distance of 1 cm from the source has confirmed Rutherford's prediction. The "central charges" covered about half of the atomic mass of the substance³⁰⁸³ which proved to be good guess after later discoveries of neutrons.

In 1913 at the 2nd Solvay Congress Rutherford had already demonstrated the advantages of his description of the atom in his paper scheduled after Thomson's report. The following year he estimated the size of nucleus to be less than 1.7 fm, which was even slightly below then relevant estimate of the size of the electron. He approached the later concept of binding energy or mass defect.³⁰⁸⁴

In 1906, **Hans Wilhelm Geiger** from Neustadt an der-Weinstrasse finished his studies with associate professor Wehnelt in Erlangen. Then he worked with Rutherford for seven years. In 1911, he published a relationship between half-life and energy of α rays. In 1912 he began to run his own laboratory at Physikalisch-Technische Reichsanstalt in Berlin, which was created by Helmholtz and Werner Siemens. In 1925, Geiger proved that energy and motion were maintained at Compton's scattering phenomenon. Between 1925 and 1929 he was a professor at the University of Kiel, until 1936 he taught in Tübingen and then at the Technical University of Berlin.

Upon his return to Manchester, he began to scatter the α rays on lighter nuclei. Due to the military obligations of national-level collaborators during the First World War, his only help was a laboratory assistant William Kay (1879–1961), who, prior to his arrival in Manchester, had assembled most of the Dewar high pressure appliances in the RI. William Kay had been Chief Steward of the Manchester physics laboratory from 1908 until his retirement in 1946. In December 1917 nitrogen tests led to the first planned nuclear reaction. This was the last Rutherford discovery before going to Cavendish where he retired from ion implantation and began researching the structure of the nucleus.³⁰⁸⁵

³⁰⁸³ Geiger, Marsden, 1913, 609.

³⁰⁸⁴ Bohr, 1971, 2: 594–595; Rutherford, 1914, 494–495;

Filonovič, 1990, 195; Geiger, 1913, 604.

³⁰⁸⁵ Birks, 1963, 11–12, 52, 69, 71, 104–106, 139;

Rutherford, 1919, 37.

28.1.7 *Bohr in Manchester and Copenhagen: the Theory of Ion Implantation*

In August 1912 and July 1915 Bohr linked the results of Rutherford's laboratorial measurements to a convincing theory where the absorption of α rays in the heaviest elements was determined by the number of electrons in their atoms and with their characteristic frequency. The average absorption of fast particles was supplemented two years later by his investigating of the loss of velocity of individual particles. Bohr noted only the influence of electrons but ignored the nuclei of atoms in his estimation of the decrease in speed or energy loss per unit of the path. The slowing of α rays and other ions in heavier elements was roughly described by the idea that the heavier elements have, along with external electrons with their own natural frequencies in the visible range, also the electrons bind by higher energy with their own natural frequencies in the X-ray range.

Thomson's theory predicted the correct results, considering secondary ionizations caused by electrons ejected out of atoms. Bohr's work was supplemented by more realistic theories by Rutherford's occasional associates Bethe and Swiss Bloch from the University of Leipzig, later director of CERN. In 1952 Bloch received half of the Nobel Prize in physics for his discovery of nuclear magnetic resonance, and Bethe earned his award two decades later by exploring nuclear reactions in stars.³⁰⁸⁶

After C. Christiansen, Martin Knudsen became the professor physics in Copenhagen in 1912. Therefore, in July 1912 Bohr was left only as a private docent at his Alma Mater. In the autumn of 1914, he took over Darwin's "Schuster" lectures of mathematical physics at Rutherford's Manchester until he got a post of a professor in Copenhagen in the summer of 1916. In the following decades, he developed the most influential physical "school" of his time, which developed the modern quantum mechanics during the World War I which left the Denmark happily neutral. In 1918 he described the principle of correspondence, with which classical mechanics connected with the emerging quantum theory. In 1922, Bohr received the Nobel Prize in physics for exploring the structure of atoms and

³⁰⁸⁶ Bohr, 1970, 1: 83, 216, 245–246; Ryssel, Ruge, 1986, 5.

resulting radiation. After the German occupation of Denmark, he fled to England and then to the United States where he decisively helped the production of an atomic bomb. After the war, he returned to Copenhagen as a famous physicist. He was comparable only to Einstein, whom he often opposed in physics, especially for the notion of principle of complementarity developed as Bohr's reaction to Heisenberg's uncertainty principle in February-March 1927, which Bohr publicly described for the first time at the International Physical Congress in the town of Como on the centenary of the death of Alessandro Volta on 16 September 1927.

The son of Jewish mother **Niels Hendrik David Bohr** was born in Copenhagen. He studied physics there, got a master's degree in 1909 and took a doctorate on 13 May 1911. After his PhD, the scholarship enabled his studies at Thomson's Cambridge. Bohr met Rutherford for the first time in October 1911 at an annual dinner in Cavendish, but only a few weeks later he befriended him during Bohr's visit to his father's friend in Manchester.³⁰⁸⁷ Since Thomson did not show much interest in the descriptions of atoms that opposed his own, Bohr preferred to go to Manchester in mid-March 1912. There Bohr as theoretician accompanied by the experimental physicist Rutherford created an effective circle of advocates of the nuclear model of the atom. Rutherford's laboratory was constantly checking Bohr's ideas, and Bohr theoretically supported Rutherford's model of atom. Their relationship was spiced up with a lot of humor. Rutherford did not respect the theoreticians. At the end of a Heisenberg's colloquia at Cambridge, Rutherford declared: "We are all much obliged for your exposition of a lot of interesting nonsense, which is most suggestive." Therefore, people were wondering why Rutherford had a totally different attitude to Bohr's theory. An excited athlete and the fan of soccer, Rutherford, came up with the answer: "Bohr - he is completely different, he is a footballer."³⁰⁸⁸ Nevertheless, Rutherford disliked uncertainty even in Bohr's interpretations. Bohr delivered first prestigious Memorial Lectures of A.W. The Scotsman, Phillips Professor of physics and mathematics at St David's College, Lampeter in Central Wales. Bohr narrated on the uncertainty

principle in Cavendish on April 28-May 2, 1930. Rutherford could not remain without a note: "You know, Bohr, your conclusions seems to me to be as uncertain as the premises upon which they are built."³⁰⁸⁹

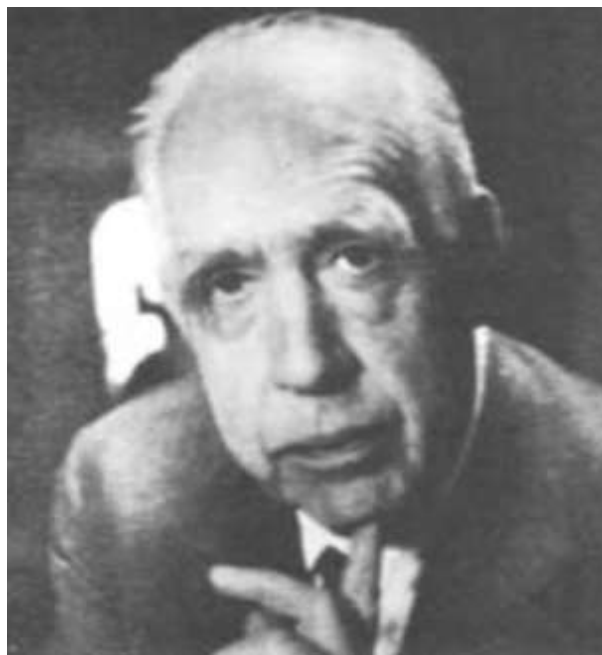

Niels Bohr (* 185; † 1962)³⁰⁹⁰

Despite significant achievements, ion bombardment for a long time remained a specially adapted experiment to prove the nuclear model of the atom, and after 1917 to trigger nuclear reactions. Initially, nobody investigated any applicability of the procedure in other fields. They considered it only as laboratory specificity, like half a century before that happened to cathode ray tube and sputtering. Basically, the forces which stopped the ions in matter were investigated while the opinions of Bohr and his Danish counterparts prevailed. In 1948 Bohr described the basics of the transition of ions through the substance. He published a special law on the exchange of energy along the path of the ions and evaluated the gradual reduction in the charge of ions. At the beginning of the transition of ions through the substance, the collisions with electrons are dominant. In the end of the transition of ions through the substance, when the ions are slowing down and mostly losing their charge, the collisions with nucleuses prevail. The equation illustrated the effect of the charge of ion and its velocity on the

³⁰⁸⁷ Bohr, 1971, 2: 545-546.

³⁰⁸⁸ Kedrov, 1980, 106-107.

³⁰⁸⁹ Weinberg, 1986, 147; Badash, 1987, 350.

³⁰⁹⁰ Bohr, 1985, 24.

number of electrons that the ion captures during its penetration through the substance. Bohr's namesake Dr. Niels Ove Lassen (1914 Hammel-2008) continued Copenhagen investigations with measurements of energy loss of particles formed after the fission of nuclei along their path through argon and other gases. Later, the Danes Jens Lindhard and Morten Scharff (1926 Tibirke 60 kilometres north of Copenhagen-1961 Copenhagen) developed the foundations for understanding the stopping of high and low energy ions while penetrating the substance. Their collaborator Hans E. Schiøtt helped them describe the energy range of ion implantation using real interactions between nucleuses and electrons, which were no longer regarded as free particles. According to the initials of the authors, the theory was named LSS. With precise measurements of ion reach in matter of John A. Davies (1927-2016) of Chalk River Nuclear Labs in collaboration with Aarhus University in Denmark and other followers of Rutherford's work in Canada, the ion implantation techniques developed more rapidly than sputtering of thin films.³⁰⁹¹ The longtime delay in its industrial applications enabled the already prepared mature theory of ion implantations ready for use in techniques, just like the Goddess Athens birth from the forehead of Zeus.

28.1.8 *Rutherford's Research Affects the Networks of Slovenians*

The physicist Fran Čadež of Carniola, a former Boltzmann's Viennese student, reported on the research of ionized particles in the matter in the Slovene language: "Alfa-rays ... at a small distance of 6-8 cm from the radium already quietly stop in the air. They did not make their short paths unsuccessful. All the air molecules they encountered along their path were split immediately into atoms or ions. A single α -particle disperses in its path over 100,000 molecules into ions. How much greater the influence of all the α -particles must be!"

The Slovenian reader was convinced in the equivalence of helium and α rays, already a year before Rutherford's finally recognized proof, although still somewhat in relation to the obsolete

JJ Thomson's assumption of the structure of the atom: "We already asked the question about what are those clusters of electrons that leave individual radium atoms at a speed of 10,000 kilometers per second. We were already discussing these clusters at our notes on α -rays described as positive electric atoms, which are only twice heavier than hydrogen. The chemistry teaches that this weight is unique to atoms of the gas helium. It is then considered that α -rays consist of helium atoms and that there is so much of them accumulated near the radium to enable our investigation. Indeed, it has already been proven in several ways that there is always some helium around the radium..." And later: "Rutherford tested the α -rays' passage through various substances and came to the following view of the composition of atoms: each atom represents a complex, planetary system with central nucleus. It attracts other smallest parts and combines them into the whole atom in the smallest space to rotate around the nucleus as the planet around the sun. Space: macro-cosmos! And by applying electron theory, Rutherford put it that these smallest parts of the atoms are nothing else than electrons - those are the smallest atoms of electricity. Thus, the matter of all bodies is electrically formed: the matter consists of atoms which consist of electrons."

The Slovenian ancestors could read the explanation of new experiments, which later proved inaccurate: "In the most recent times, even a fourth type of rays was discovered as they constantly radiate from the radium. They consist of atoms that fully match α -particles, they differ only in that they are not positively electric as α -particles, but negative. What are their effects, the future will clear up."³⁰⁹² The subsequent studies did not confirm the existence of such particles, possibly related to "Goldstein's rays", Righi's electrically neutral "magnetic rays" or Blondlot's "N-rays."³⁰⁹³

The Slovenian reader thus followed Rutherford's achievements. In his native language, he could be convinced of the benefits of the nuclear model of the atom: "Rutherford concluded that the helium atom should be the carrier of this positive electricity, and T. Royds confirmed this assumption spectroscopically. α rays are helium atoms, each bearing two elementary quantities...

³⁰⁹¹ Bohr, 1971, 2: 446, 454, 469; Ryssel, Ruge, 1986, 7; Dresselhaus, Kalish, 1992, 35.

³⁰⁹² Derganc, 1917, 103; Čadež, 1908, 39, 33, 35.

³⁰⁹³ Carazza, Kragh, 1990, 12.

Positive electrons cannot be classified in the surface of such a large sphere, but must be concentrated in the minimal space in the so-called atomic nucleus, which is very small, certainly less than 10^{-12} cm, almost 10^{-16} cm in size... The electrons are not enclosed in a positive electric sphere but circulate around a positive nucleus like the planets around the sun." The discoveries, of course, aroused excitement: "What alchemy could not do, radiochemistry is capable today."³⁰⁹⁴

The close cooperation between Viennese and Manchester researchers enabled Slovenian erudite to supplement Rutherford's discoveries. Later Ljubljana professor Sirk was one of the most important researchers of radioactivity in the Habsburgian monarchy. At the Physical Institute in Graz, Sirk also continued Rutherford's research of the radioactivity of thorium. In 1913, Sirk started working at the Viennese Institute for Radium Studies, which, under Stefan Meyer's leadership, worked closely related to Rutherford's laboratory in Manchester between 1910 and 1920. Thus, in 1910 as the Uppsala postgraduate in Vienna, Hans Pettersson (Pettersson, 1888–1966) observed the thermal phenomena caused by the β and γ -radiation of the radium. He researched the equilibrium of the ionization flow in parallel with similar research in Manchester. After his transition to the newly established Institute for the Study of the radioactivity in Vienna, on 13 March 1913 Sirk published a discussion on the pressure drop of the pulsating glow discharge under the influence of a transversal magnetic field. He continued the exploration and research of Goldstein (1881), who was the only one dealing with the transfer of particles of gas at glow pulsating discharge, albeit with too few precision devices needed for useful measured data.³⁰⁹⁵ In the theoretical part of his discussion, Sirk showed that the average mean free path in the gas is much smaller than the size of the vacuum vessel, which has already been proved by Puluj according to Stefan's theory in contrast to Crookes (1879) and Stokes' opinions.³⁰⁹⁶

During the summer of 1923 and December 1927, there was a sharp exchange of views between Cavendish and Viennese researchers on the measurements of artificial nuclear fission and

Rutherford's atomic model. In June 1924 in Vienna, the Swede Hans Pettersson (Pettersson) and Gerhard Kirch sent to Rutherford a discussion on their bombarding of charcoal and aluminium with α rays. The results were published two months later at a gathering of German naturalists and doctors in Innsbruck and in Vienna under the title *Über die Reflexion von α -Teilchen an Atomkernen* in 1925. In May and December 1927, Pettersson and Chadwick in vain tried to settle down the disputes with the people researching in Vienna by comparing their experimental techniques of their highly personally experiences of counting of scintillations as no instrument was invented for that job as far. The situation resembled Galileo's three centuries earlier experiments using the experienced singers of repeated rhythmical Italian songs as an aid for the measurements of times of accelerated motions when no accurate clocks were available. Pettersson later mostly researched oceanography while Kirch focused his work on geomechanics.

Rutherford worked all the time in collaborations with Viennese physicists. Rutherford sent to Vienna his discussion on the thermal effects of α rays, together with his demonstrator and assistant at the University of Manchester, Robinson. They sent their results to the Viennese Academy in July 1912, which the Viennese published after half of a year. It was only between 1927 and 1933 that Rutherford arranged a payment for the radium rented in 1908, and thus saved the Viennese Institute for the Study of Radium of the severe material shortages. Rutherford's Hungarian associate the Jewish Catholic Hevesy, along with the Jewish Protestant Frederic Paneth (Fritz, 1887 Vienna-1958 Mainz), experimented in Vienna in early 1913. In 1916, Natanson's student the Jewish Pole Stanislaw Loria (1883 Warsaw-1958 London) researched at the Viennese Institute of Radium Studies with experiments like Sirk's. He later worked at Rutherford's labs in Manchester.³⁰⁹⁷

28.1.9 Conclusion

The first uses of ion implantation were associated with various descriptions of the properties of the α radiation at Rutherford and H. Becquerel's networks. Soon the distribution of mass and charge

³⁰⁹⁴ Čadež, 1908, 31, 37; Čermelj, 1980, 97, 148, 110.

³⁰⁹⁵ Goldstein, 1881, : 262; Sirk, Ein Druckgefälle im Glimmstrom bei Einwirkung eines Transversalen Magnetfeldes, Wien. Ber. 122 (13. 3. 1913) 417.

³⁰⁹⁶ Puluj, version 1889; Wilson, 1987, 201.

³⁰⁹⁷ Staroseljskaja-Nikitina, 1967, 131, 180–181, 231; Birks, 1963, 36, 131; Brown, 1997, 8, 12, 77–88, 95.

inside the atom became an apple of dispute, while Rutherford's former teacher, Thomson, turned into Rutherford's main enemy. Their antagonism illustrated their generation gap and had a significant impact on the early development of quantum mechanics. Four decades after the discovery, ion implantation remained primarily a tool for investigating of the incident and fired particles, but fewer literati researched the targets. They investigated the properties of α rays and radioactive products, and not the changes in the bombarded targets. Thin targets were mostly made of metals, while the development of ion implantation was later mainly associated with semiconductors. Before the Second World War, ion implantation was not used in industry, in complete contradiction with modern developments, when research has shifted from missiles to targets whose properties were changed by implantation. And the last became the first, just like in the Bible.

28.2 Discovery and Development of Transistor

28.2.1 Introduction

In 1998, the transistor met Abraham as it turned fifty. We do not know why Abraham's famous birthday is put right in the fifties, but it's nice to remember interesting stories. Perhaps no discovery in physics has ever so rapidly affected human life as did a transistor. That's why its discoverers were awarded the Nobel Prize in 1956, the first one granted for an engineering device after the fifty years of waiting. The transistor was not the result of a planned experiment but emerged from a broad program of co-investigating scientists. In addition to physicists, experts in electronics, physical chemistry and metallurgy were also involved in the discovery.

28.2.2 The Discovery of Silicon and Germanium

Gay-Lussac and Tenar researched their first silicon in 1811. Its elementary nature was proven dozen years later by the Swede Berzelius, who obtained it from silicon fluoride. On 17 February 1869 Mendeleev classified silicon into his periodic system. Beside it, he also envisioned "eka-silicon".

Its properties were announced at a meeting of the Russian Physical Society on December 3, 1870. Mendeleev tried to extract a new element from titanium and zirconium compounds between early December 1870 and mid-December 1871. He reported to German chemist Erlenmeyer during his survey. A similar element was considered by the Englishman Newlands in his periodic table of 1864, but he did not have a real echo. In 1886, "Eka-silicon" was discovered by professor of technical chemistry at the Royal Academy in Freiburg in Saxony, Winkler. He obtained it by analyzing the argyrodite mineral, which was found in a mine near Freiburg by Ludwig Julius Weisbach, a professor of mineralogy at the same Freiburg Academy. In February 1886, that new element named germanium was reported to the German Chemical Society and the discovery supported Mendeleev's predictions and notifications.

28.2.3 Early Semiconductor Research

The semiconductors caught Faraday's attention on April 15, 1833. Contrary to the conductivity of metals such as described Davy in 1821, the Ag_2S conductivity increased with increasing temperature: If a 1 cm thick piece of Ag_2S (sulfuret) is placed on the surface of the platinum between the poles of the voltaic battery with twenty pairs of plates 10 cm wide, the galvanometer needle will only be slightly deflected in its circuit due to the small conductivity of Ag_2S . When we press with fingers the platinum to the sulfide, the conductivity will increase due to heating. With the heat of the lamp under the sulfide, the conductivity increases rapidly, but finally the galvanometer jumps into the permanent position and Ag_2S starts translating just like metal. After the lamp is moved away, the phenomena are followed in the opposite order... Except for the hot Ag_2S , I do not know any other substances that could be compared with the metals in the translation of low-voltage electricity, but when they cool down they lose this ability, while metals, on the contrary, are gaining it. We will probably find many more of these substances when we search for them..." In December 1838, Faraday fulfilled his forecast and continued the measurements on other semiconductors, especially on lead fluoride. Today we know that Faraday erroneously represented the translation of electricity in all substances in the same way; he

distinguished only the magnitude of the conductivity of individual substances, while Faraday's mechanisms of translation seemed to be unitary.³⁰⁹⁸

28.2.4 *Stefan-Braun's Discovery of a Potential Barrier in a Crystal Diodes (Detectors)*

In 1865 the Slovenian Stefan discovered strong thermoelectric voltages between the karst pyrites and the Lead (II) oxide PbO in its tetragonal crystal structure (litharge). In a short preliminary notice on the course of his research, he described the combinations of some sulfur ores with an unusually higher thermoelectric voltages compared to the combinations of pure metals. He presented thermocouples that greatly outperformed the Sb-Bi thermocouple. He measured fourteen different pairs of substances with Daniel's galvanic battery, while some measurements with copper were already performed by Bunsen. In 1857 and 1865, the Jewish assistant working for Stefan and Stefan's mentor physiologist Karl Ludwig as technician in the Physical Institute of the Medical School Siegfried Samuel Marcus (1831 Malchin in northern Germany-1898 Vienna) described his constructions of thermocouple. The design endorsed by the Parisian Academy, and his work was subsequently continued by E. Becquerel with measurements of CuS between 300°C and 400°C with Daniel's battery. Marcus also first used petrol to propel a vehicle in the simple handcart of 1864. In 1865 just before Stefan's report Marcus published his paper Ueber eine neue Thermosäule at the journal of Viennese academy.³⁰⁹⁹

Stefan's research of translation in semiconductors was just a prelude to his much more famous main topics focussed on translation through gases crowned with his measurements with diathermometer for the development of vacuum insulation in 1870s. Karl Ferdinand Braun followed the same path as his research of translation in semiconductors in 1870s became just another prelude to his much more famous cathode ray tube of 1890s. The research of solids was not of primary concern in the era after the spring of

nation of 1848 when even the kinetic theory itself relied on gaseous examples. No matter how industry might have needed the more profound research of solid state material and its uses, academic research of those times could not prosper much in solid state topics while everybody was interested in gases even if Stefan loved to use for them his hydrodynamic analogies. The main topic of condensed matter physics called solid state physics as the basis of material science emerged as a separate field of solid-state physics only in the 1940s with the establishment of the Division of Solid State Physics (DSSP) within the American Physical Society. In the times of Stefan and Braun the researches of solid states were only sporadic until the great attention was focused of liquefaction and solidification of "permanent" gases and the phase transitions involved.

Almost ten years passed until Karl Ferdinand Braun continued Stefan's measurements with a discovery of the potential barrier which directs the translation in semiconductor crystals. Braun discovered rectification in metal-sulfide semiconductor contacts. He began his measurements as Quincke's assistant in Würzburg, since he published the first discussion on 23 November 1874, only two months after moving to the Grammar School St. Thomas in Leipzig, where he used crystals from a Grammar School (gymnasium) collection. Braun measured the contact between a silver conductor and a semiconductor crystal. He was aware that such an experiment with at least one small electrode was the most suitable for observation. The first of six Braun's publications on electrical conductivity of semiconductors in Ann. Phys. showed the limited value of Ohm's law, which he tried to complement with the constant and the factor depending on the square of the electric current. In the measurements, he used eight Grove's elements. He quoted Hittorf's measurements and extensive Herwig's study of the conductivity of iron and steel, but he probably did not know Stefan's work.³¹⁰⁰

Without any persuasive theory, the research of 24-year-old Braun did not get any good reputation. His experimental technique was so demanding that the French mineralogist Henri Dufet announced after unsuccessful experiments on pyrite that Braun had made a mistake. WG Adams and RE Day in England, and EW Siemens in Germany, when

³⁰⁹⁸ Faraday, 1952, paragraphs 434, 439 (page 123 in the edition of 1839), 1340-1341 (pages 426-427 in the edition of 1839).

³⁰⁹⁹ Stefan, 1865; Adlešič, 1952, 453 .

³¹⁰⁰ Braun, 1874, 561, 562.

researching the influences impacts of light on electrical properties of selenium also faced difficulties in obtaining unequivocal, reproducible results.

In 1875 Braun presented his discovery in front of a Naturalists Association in Leipzig, where among his listeners were a former Magnus' student, professor of Physical Chemistry GH Wiedemann, and Wilhelm Hankel as a professor of physics and researcher of electrical properties of crystals. At the end of the lecture, Braun successfully demonstrated the deviation from Ohm's law at the measurement of brown manganese, which was not sulfide, and PbS. The deflection of the galvanometer depended on the direction of the current. He explained that Dufet did not get the expected results because he used a contact of the same size. One contact should be formed in a thin tip, which Braun did not emphasize enough in his first discourse in 1874. Instead of general theory, Braun offered only clever guesses. He assumed that a thin surface layer would direct the electric current to a point electrode. The current remained the same if it ran across the crystal to a single electrode or a pair of electrodes. If the phenomenon concerned the total volume of the crystal, the current should be half as low as the experiment with two electrodes.

Braun pointed out that the rectifying also occurs when the current flows only for 1/500 s. That was too little for the warming, which, according to E. W. Siemens, would have caused Braun's results. Thus, Braun attributed to the discovery of two fundamental properties of a later transistor, in which the changes occur in a superficial layer at a high speed.³¹⁰¹

In his last discussion about the semiconductors in 1878, Braun used a plate of dimension 8 mm × 35 mm × 20 mm from psilomelane (hard black manganese oxide).³¹⁰² For contact, he made a metal clamp which he strongly tightened to the psilomelane plate that he insulated with paper. Only a peak of a clamp made of platinum 3 mm long and 2 mm thick with its semicircular tip was touching the minerals.

The platinum is softer than psilomelane, so, when Braun tightening it, it caused a stain measuring 1/3

mm², which Braun observed under a microscope. The stain could not be scratched away with paper or smooth steel but could be removed only together with neighboring fragments of psilomelane. The pressure of the ambient air did not influence the measurement, and the electrolytic effects did not cause change in resistance. Hittorf studied Ag₂S likewise. Obviously, that Braun's stain had some similarities with stains obtained by sputtering.

Braun searched for the analogy between translations in semiconductors and translations in gases, which was also dependent on the direction of flow under certain conditions. Because the gases were still the main topics of research of physics of those times, every aspect of physics had to be compared to the phenomena in gases to make it a part of mainstream. Braun measured the resistance to the current e with a differential galvanometer on a plate with five contact screws. The resistance in psilomelane was different in opposite directions, like that of the Geissler tubes with funnel valves. Three quarters of a century later Shockley shared the same Braun's opinion while Barden view was the opposite.

Braun also measured the dependence of the distribution of fluxes from the magnetic force at his psilomelane. He wondered if resistance was a property of a current of charges or could it possibly be a property of molecules of matter? Does the variable induction current through the substance change at the same time the resistance compared to its value of at a constant flow, or the discharge method have no effect? Braun tried to confirm the second claim.

Maxwell's assistant at Cavendish Laboratories in Cambridge Schuster measured the contacts between his purified and then then oxidized copper conductors and sulphides. His English results deeply resembled Braun's German claims³¹⁰³ on behalf of French ideas. The dissymmetry (asymmetry) was slowly penetrating into physics and related fields from crystal optics of Malus, Haüy and Biot. In 1820 and 1827 Sir John Frederick William Herschel (1792-1871) offered dissymmetry as the explanation of Biot's optical experiments while Louis Pasteur offered to Biot his chiral molecules of recrystallised salt of tartaric acid with two kinds of small crystals that were mirror images of each other in 1848.

³¹⁰¹ Kurylo, Susskind, 1981, 28–34.

³¹⁰² BaMn₉O₁₆(OH)₄

³¹⁰³ Braun, 1878, 436–447, 479–482, 484.

28.2.5 *Semiconductor Research before World War II*

As Herschel and Hanoverian dynasty before him, their fellow compatriot German Schuster also proved to be a blessing for Brits. The German **Arthur Schuster** was born in Frankfurt on Main in a rich Jewish family which was dealing with textiles. When Frankfurt was annexed to Prussia in 1879, the family moved together with their companies to Manchester where Engels also concentrated his business. The physics became passion of Arthur Schuster after his reading of spectral analysis textbook of Henry Roscoe who, together with Stewart, later taught at the University of Manchester. In 1872, Stewart highly estimated Schuster's research of the nitrogen spectrum. Roscoe enabled Schuster's doctoral studies at Kirchhoff and Bunsen's Heidelberg, where Schuster completed his Ph.D. in 1873. In the summer of 1874 in Göttingen, he assisted Weber's testing Ohm's law for AC currents of high frequency known as "unilateral" conductivity by which current can flow in one direction only. Schuster also worked for some time with Helmholtz in Berlin, where his peer Goldstein then studied discharges in the cathode ray tubes. Schuster discovered the "Schuster phenomenon", where the electrical current from the rotating magnet constantly increases the average deflection of the pointer of the galvanometer. Therefore, he announced that the resistance of the wire diminishes by stronger currents at a meeting of the British Association in Belfast in 1874. Maxwell was interested in Schuster's claim, because he did not have a strong theoretical justification for Ohm's law, which was challenged by Schuster's experiments. However, in the spring of 1876, the Cavendish Laboratory found that the "Schuster phenomenon" was only the result of uneven magnetization in the magnet and in the coil. In 1875, Schuster received English citizenship. In October 1877 he started working in Cavendish and in 1884 he was the main competitor of J. J. Thomson for managing Cavendish. In 1881, he became a professor of applied mathematics at the University of Manchester, and in 1887, after Stewart's death, he took over Langworthy's Department of Experimental Physics where he selected Rutherford as his successor twenty years later.³¹⁰⁴ The choice proved to be a good one.

In 1874 Braun's discovery of crystalline diode began the research of contact potential barriers in which germanium had not yet been used.³¹⁰⁵ As much as thirty years later, contacts of metals and crystals for "detectors" of radio signals were utilized. These early-radio crystal amplifiers were in use even in the 1950s.³¹⁰⁶

From 1880 to 1884, **Jagdish Chandra Bose** studied in Cambridge with the new director of Cavendish laboratories Rayleigh. From 1885, Bose was a professor in Calcutta, where he investigated the detectors and lectured about them for RI with Rayleigh's recommendations. Bose's mercury detector, reported by Rayleigh in front of the RS on March 6, 1899, was used by Marconi to receive the first transatlantic radio signal on 12 December 1901.

At the dawn of the new century, the India native Bose invented and patented the first crystal detector in the United States (Figure 28-9).³¹⁰⁷ In 1906, the crystal detector was patented by H. H. C. Dunwoody and G. W. Pickard, and independently by the Berlin Telefunken. The metal axis or crystal was attached to the crystals of carborundum (Silicon carbide, SiC), galenite, pyrite, etc. On 5 October 1910 in the US Benjamin Franklin Miessner (1890 Indiana-1976 Miami) patented Braun's electrode with a conductor as a "detector for radio".³¹⁰⁸

The basics facts about transistors were known at a time when researchers from Shockley's group at Bell Labs were still the teenagers. After the First World War, triodes and other cathode-ray tubes pushed out crystalline detectors of the market. During many decades, the kingdom of cathode ray tubes so sharply embraced all the mainstreams, that any competitive solid-state research looked like a heresy while the semiconductors secretly prepared their comeback. Only a handful of brave researchers were still studied the semiconductors outside mainstream, including the Russian noble without formal academic education Oleg

³¹⁰⁵ Schopman, 1988, 170.

³¹⁰⁶ Adlešič, 1952, 453.

³¹⁰⁷ Bondyopadhyay, 1998, 221.

³¹⁰⁸ Miessner, 1910, American patent no.1104065.

³¹⁰⁴ Fox, Guagnini, 1999, 120, 127; Feffer, 1989, 35–37, 39–40; Darrigol, 1998, 17; Brown, 1997, 7.

Vladimirovič Losev (Олѣг Владимирович Лосев, Lossev, Lossew, 1903 Tver-1942 Leningrad), who built a zincite oscillator between 1919 and 1923 as the precursor of a later tunnel diode. The Habsburgian Jew Lilienfeld was a professor of physics at the University of Leipzig between 1910 and 1926; he published a study on field electron emission in vacuum in 1920. He continued his research of vacuum cathode ray tube with his studies of solid matter. After emigrating to the United States, he was director of research at Ergon Research Laboratory in Malden, Maryland. Between 8 October 1926 and 1932, he filed and obtained three patents for the basics of a transistor with a field effect (metal - oxide - semiconductor, MOSFET).³¹⁰⁹ He suggested using CuS, but it is not known that he ever designed a functioning transistor amplifier. In 1935, he became a citizen of the United States.



Figure 28-9: Bose with a first patent of a semiconductor device in the world on 30. 9. 1901³¹¹⁰

In 1935 the German Oskar Heil (1908 Langwieden in western Germany-1994, San Mateo, California) in Britain filed a patent describing the operation of the MOSFET using modern theory of electrons and holes (gaps) developed by A. H. Wilson in Cambridge in 1931. Heil described both the n-type and the p-type in the tellurium, iodine, Cu₂O, and V₂O₅. Heil in fact produced the precursor to the modern FET, while C. Zener designed diode named by him. In 1935 Heil and his wife a promising young Russian physicist Agnesa Arsenjewa (Агнесса Николаевна Арсеньева, 1901–1991) in

³¹⁰⁹ Metal Oxide Semiconductor Field Effect Transistor.

³¹¹⁰ Bondyopadhyay, 1998, 220.

their pioneering German paper developed the concept of the velocity-modulated tube, in which a beam of electrons could generate with reasonable efficiency radio waves of considerably higher frequency and power than with conventional vacuum tubes/thermionic valves. "Heil tube" became the first practical microwave generator. Around 1935, electric switches of valves with copper or selenium oxides were developed; they were named "Westector" in the USA, while in Germany they called them "Sirutor". As Lilienfeld's and Heil's research was largely forgotten during the war, their discoveries were merely complemented by the p-n junctions for field-effect transistor (FET) and the minority carrier injection in Bell Labs between 1947 and 1952 (Figure 28-10).³¹¹¹

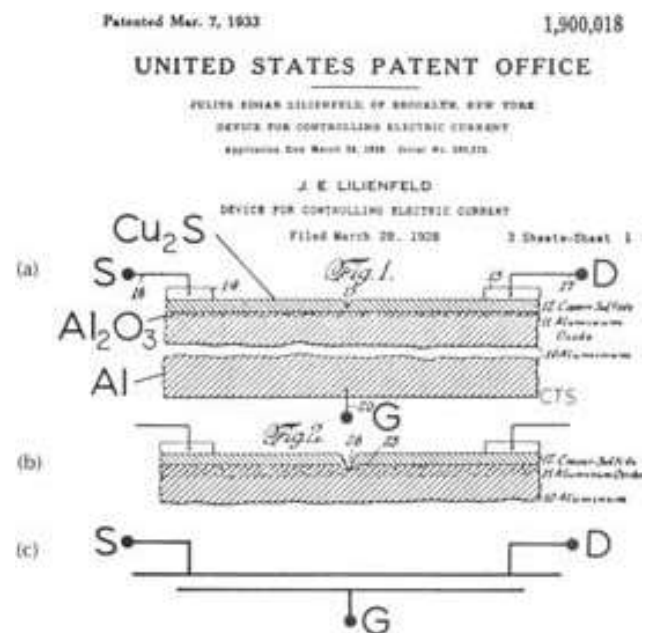

Figure 28-10: Lilienfeld's patent with the MOSFET Structure in 1933³¹¹²

It turned out that the specificity of the semiconductors in the illumination and in the rectifiers are surface appearances, while the photoconductivity and the negative temperature coefficient of resistance are related to the volume. At the end of the 1920s, semi-conductivity was found to depend both on the number of charge carriers in the volume unit and on their mobility, determined by the ratio between the speed of carriers in the electric field and the strength of that field. In the following years, the measurements of Hall effect have shown that the values of both

³¹¹¹ Waits, 2000, 1736; Wegmann, 1981, 1.

³¹¹² Sah, 1988, 1282.

quantities in semiconductors differ greatly from metals. The density or the number of charge carriers in the metal is not nearly constant only at the transition from one metal to the other at their contact, but also in the case of temperature changes. The density of charge carriers is different in semiconductor, and for several orders of magnitude smaller than in metals.

The solid-state researchers had to wait until the military development of radar stimulated again the exploration of crystal diodes with the transition to higher frequencies where the cathode ray tubes were not usable. Around 1938, stable detector was assembled by depositing a metal nail on the germanium crystal plate. H. Wilson explained many properties of a semiconductor with quantum mechanics behavior of electrons in solids with discrete energy bands in Cambridge in 1931. Already in 1917 in Phil. Mag. Frenkel from the University of Petrograd qualitatively explained the existence of an electrical double-layer (closure),³¹¹³ which in the subsequent Bardeen's version had received strong experimental support. In 1932, Frenkel described a metal-semiconductor with a quantum-mechanical tunneling.

Edwin Hilbert Hall discovered the phenomenon called with his name in the United States in 1879. Between 1881 and 1921, he taught at the Harvard University.

The Swiss German **Walter Schottky** studied under supervision of the professor Sommerfeld. Between 1916 and 1919, and after 1927, he researched with Siemens & Halske.

In 1927, the son of Norwegian migrant American engineer Lars Olai Grondahl (1880 Hendrum, Minnesota-1968) in Westinghouse's Union Switch and Signal Company in Pittsburgh tested his plates of Cu_2O at higher temperatures around 1000°C . They were excellent conductors of the electrical current in one direction, while they had a high resistance in the opposite direction. Thus, it was possible to obtain DC current from the alternating current while Grondahl became famous enough to

teach at University of Washington in Seattle and then at the Carnegie Institute of Technology.

The first photocell with copper- Cu_2O insulating layer was patented by Grondahl's collaborator assistant director of Union Switch and Signal Company Paul Harold Geiger (1896 Paris, Michigan-1954) on 14 November 1926.³¹¹⁴ The device was improved by Schottky and Emil Duhme after his Gottingen PhD at the Siemens & Halske Laboratory and independently of them F. Haber's PhD student at Berliner university Bruno Albert Lange (* 1903 Berlin; † 1969 Berlin) at 6th German Physics Days in Kaliningrad from 4th to 7th September 1930. Schottky described the operation of the submicroscopic thin layer between the surfaces of copper and Cu_2O .³¹¹⁵ Despite the discovery of Braun, the phenomenon was called "Schottky's effect."

According to Bardeen, Schottky could have detected a transistor by examining in detail the behavior of the n-type semiconductor gap near the contact.³¹¹⁶ Of course, then he would have taken over Bardeen's first Nobel Prize. Schottky's similar theory of the obstruction of a thickness of about $1\ \mu\text{m}$ at the boundary between a semiconductor and a metal was also published by Bristol professor Mott, and by Ukrainian Jew Ioffe's student the Jewish editor of Boltzmann's, Einstein's and Smoluchowski's works Boris Davidov (Davydov, Борис Иосифович Давыдов (1908 Petersburg-1963 Moskva) in Ioffe's Physico-Technical Institute in Leningrad in the Soviet Union before the Second World War. In 1977, Mott shared Nobel prize in physics with D. Haldane's teacher Philip W. Anderson and John H. van Vleck.

28.2.6 Junction (Point Contact) Transistors

Point-contact contact semiconductor diodes were indispensable during the war for their uses in radars and other electronic devices. In 1940 in Bell Labs Russell Shoemaker Ohl (1898 Pennsylvania-1987 California) asked chemists and metallurgists for a more homogeneous material that would have more stable properties than silicon. They obtained much purer materials than they ever, and even

³¹¹⁴ Schröter, 1932, 175.

³¹¹⁵ Trigg, 1978, 177; Schröter, 1932, 165–166, 175–176.

³¹¹⁶ Holonyak, 1992, 38, 37

³¹¹³ Trigg, 1978, 175.

controlled the type of their defects and impurities. Their conductivity was caused by smaller amounts of these impurities, which Ohl divided into n- and p-types.³¹¹⁷

On 29 December 1939, Shockley wrote down what the future "transistor" is supposed to be. On 29 February 1940, his idea was improved with a description of the later MOSFET (Figure 28-11). After the war,³¹¹⁸ he became head of the group of researchers of germanium and silicon at Bell Labs. It was easier to work with elementary substances, and the technology for them was already developed, although copper oxides and ZnO were much more used in those times.



Figure 28-11: Shockley's transistor sketches with Brattain's signature on 29 February 1940.³¹¹⁹

Besides technological, they also tackled the theoretical problems. According to Schottky, the barrier closing layer consists of a spatially charged region of a semiconductor of thickness from 10^{-6} cm to 10^{-4} cm and an induced charge on the surface of the metal. The spatially distributed charge raises electrostatic potential energy on the surface of a semiconductor. The electrons are exhausted from the area with spatial charge, which can enable high resistance of the layer.

If the potential of a semiconductor is negative with respect to metal, the energy levels in the semiconductor are raised and electrons can easily pass through higher potential in the metal. This is a translation direction. On the other hand, in a

positive semiconductor, the levels are reduced, which raises the level of barrier, so that the electron pass harder from the semiconductor to the metal. This is the closing direction.

For the first time, Ioffe's student **Igor Evgenevich Tamm** described localized states called Tamm's Levels in *Physik. Zeits. Sowietunion* (1932) 1: 733. He was followed by Shockley's paper in *Phys. Rev.* (1939) 56: 317.³¹²⁰ In 1958, Tamm was awarded the Nobel Prize for the study of electromagnetic waves emitted by particles during their rapid motions in matter.

According to Schottky, the equilibrium height of the potential obstacle and the degree of orientation depend on the output of the metal.³¹²¹ He wrongly predicted the difference between the contacts of the n- and p-type in silicon, and he was not able to explain the results of Shockley and Bell labs pioneer of solar cells Gerald L. Pearson (1905 Oregon-1987 California).³¹²² Other research supported Schottky's assumptions, among them H. Schweickert's measurements of the interdependence between resistance of selenium rectifiers and output in metal at the physics institute of Erlangen university, later Siemens' employee.³¹²³ Under the guidance of Joseph Adam Becker (Joe, * 1897 Saar land; † 1961), Brattain and John N. Shive found a good correlation between the degree of rectifying tendency directing and the output of metal contacts evaporated on copper oxide and on n- and p-type silicon in Bell Labs in 1940.

Shive got results resembling Schweickert's exploring of the contacts between various metals that were evaporated on selenium. Ioffe (Joffe) attempted to reject Schottky and Davidov's theories in Leningrad as Ioffe was a friend of Bardeen. Unfortunately, the Schottky barrier problem remains unresolved today.³¹²⁴

Due to discrepancy with experiments, Shockley group member, Bardeen, explored in detail the nature of the contact between metal and a semiconductor on February 13, 1947. He was

³¹¹⁷ Trigg, 1978, 177, 178; Kramer, 1997, 1205.
³¹¹⁸ Kramer, 1997, 1204; Trigg, 1978, 178.
³¹¹⁹ Kramer, 1997, 1203.

³¹²⁰ Bardeen, 1947, 717, 719.
³¹²¹ Bardeen, 1947, 717-718.
³¹²² Trigg, 1978, 179; Shockley, Pearson, 1948, 232-233.
³¹²³ Bardeen, 1947, 718.
³¹²⁴ Bardeen, 1947, 718; Ioffe (Joffe), 1983, 222-22.3

interested in the influence of electronic states at the surface of the semiconductor on the equilibrium value of the potential obstacle and the surprising absence of the influence of the metal in contact. However, he still lacked experimental confirmation of the existence of electronic surface states, which Shockley used in his one-dimensional model in 1939. Bardeen assumed that the electrons on the surface of the semiconductor come into balance after each electrical contact; for balance it is necessary to exchange the electrostatic potential between the interior of the semiconductor and its surface. The events within the semiconductor do not depend on contact with the metal, which explained the results of W. E. Meyerhof's measurement of the relation between the contact potential differences and rectification. An analysis of the effect on the surface of the metal and the semiconductor during the switching showed that the surface charge only slightly changes the output of the metal, and much more of the semiconductor. The localized states (Tamm levels), having energies distributed in the "forbidden" range between the filled band and the conduction band, may exist at the surface of a semi-conductor. A condition of no net charge on the surface atoms may correspond to a partial filling of these states. If the density of surface levels is sufficiently high, there will be an appreciable double layer at the free surface of a semi-conductor formed from a net charge from electrons in surface states and a space charge of opposite sign, like that at a rectifying junction, extending into the semi-conductor. This double layer tends to make the work function independent of the height of the Fermi level in the interior (which in turn depends on impurity content). The work function (the minimum energy needed to remove an electron from a solid) in n-type silicon is for about 0.25 eV different from the work function of the p-type, which is much less than the energy gap of about 1.1 eV. If contact is made with a metal, the difference in work function between metal and semi-conductor is compensated by surface states charge, rather than by a space charge as is ordinarily assumed, so that the space charge layer is independent of the metal. The characteristics of rectification are then independent of the metal. Contrary to Shockley and Shive's focus on space charge, Bardeen had surface states charge as basic for the rectification. For Bardeen, the contact surface was of primary concern, while Shockley and Shive focused their research on bulk space behind it.

Bardeen was aware of the shortcomings of his model describing close contact between the metal and the semiconductor, which prevents the separate treatment of different work function in both contacted materials. In addition to his presentation, he processed in detail the example of a uniform Schottky barrier. He described the following barriers made up of double layers:³¹²⁵

- 1) The one-atomic layer on the surface of the metal
- 2) The one-atomic layer on the surface of the semiconductor
- 3) The surface charge on metals and semiconductors with the thickness of few atomic layers
- 4) The surface charge layer, with the thickness of few atomic layers, and the spatial charge, which extends from 10^{-6} cm to 10^{-4} cm deep into the semiconductor.

Bardeen's amplifying (reinforcement) in the shutter layers can be estimated in various useful ways:

- a) For a surface density level above 10^{13} cm⁻²; the double-layer closure (4) is independent of metal and it is the same as on the free surface of a semiconductor. The rectifying (steering) capability will then be largely independent of the output of the metal. The difference in the contact potentials is compensated by the closure layer (3).
- b) For a surface density of less than 10^{13} cm⁻²; the double-layer closure (3) will be small and will be (4) approximately determined by the difference in the output section.
- c) On the close contact between the metal and the semiconductor we cannot distinguish between the double-layer closures (1), (2) and (3). Even if the spread of surface levels of the metal is small compared to the energy gap, that finding will still be valid.
- d) With large surface levels spreading, surface charge cannot be described based on measurements of potential difference at the point of contact.

Brattain and Shockley supported Bardeen's theory with experiments. Among the surface properties they considered the photoelectric effect, which

³¹²⁵ Bardeen, 1947, 717, 719, 720, 724–726.

changes the contact potential during the illumination. Immediately after their letter, Brattain described a double sealing layer on the surface of a semiconductor. At room temperature, the system should achieve a balance in a matter of seconds.

The next stage of the survey was to measure potential changes on the surface of silicon or germanium at different temperatures. The experiment was inhibited by condensation of water vapor on the cold surface of the semiconductor; therefore they soaked their system in a non-conducting liquid. They measured the contact voltages and found changes in photovoltaics during irrigation. Brattain warned colleague the chemist Robert Bernard Gibney (* 1911 Wilmington, DE) that water and some of the used liquids were not good dielectrics, but electrolytes. Therefore, it was assumed that the potential is changing between the surface of the semiconductor and the comparative electrode.

Those results were introduced to the entire research group at Bell Labs. A few days later in the morning, Bardeen came to Brattain's cabinet and described a device that could get the desired rectifications. Brattain set up an experiment in a laboratory where the metal fitting was covered with a thin layer of wax and affixed to p-type silicon. The surface was so treated that a transition to the n-type was formed. The contact was wetted with a drop of water and the electrode was placed. The point of contact was isolated from the water with a layer of wax. As expected, they discovered that the potential between water and silicon changes the current that flows over the metal point into silicon.³¹²⁶

This discovery of the amplifier has enabled the advancement of electronics in the next half century. Once it has long been known that the raising temperature of the semiconductor increases the number of electrons and holes (gaps), and the illumination multiplies the number of charge carriers, Bardeen and Brattain used the electric current to change the distribution of the media by injecting the holes (gaps) that were minority charge carriers. The positive metal electrode (emitter) in contact with the surface of the semiconductor of the n-type (base) has caused the electrical current of holes (gaps) into it.

³¹²⁶ Trigg, 1978, 183, 185–186.

In the meantime, in the middle of December 1947, Bardeen communicated to his wife with a typical silent voice while she was preparing dinner: "We've discovered something today."³¹²⁷ In the kitchen, it smelled slightly for the Nobel Prize, the first of the two earned by Bardeen. His fiancé was full of understanding and began to pour soup...

Bardeen proposed a similar experiment on germanium n-type, which would give an even better result. After discussion with Bardeen, Brattain's group compiled an electronic device with an emitter, a collector and a broad low-resistance contact on a germanium base that could be used as an amplifier, an oscillator, and more, instead of vacuum cathode ray tubes.

The name transistor is derived from "Transfer resistor". **John Robinson Pierce** coined the term after he joined Bell Labs together with Shockley. As an engineer, he mainly studied vacuum tubes for microwave devices, but he also knew the essence of semiconductor research of his colleagues. Before 28 March 1948 while they searched for a suitable name for a new device in analogy with similar resistors, thermistors and varistors, proposals on the Brattain's initiative were made as the "transmitter... trans-resistor ... transistor". And the later prevailed.

The comeback of semiconductors was a fact! It could be funny to see eventual comeback of cathode ray tubes somewhere in the future as they were never entirely abandoned for TV screens, better gramophones and the like, resembling the sailboats beaten by steamers whose gravediggers were motored ships, steam engines beaten by internal combustion for locomotives and elsewhere, gas-lamps beaten by electrical bulbs, balloons beaten by planes, carriages beaten by cars, optical telegraph beaten by electrical telegraphy, telephones nearly beaten by cellphones and likewise.

To enable transistors' victories over cathode ray tubes, Brattain's boys made two junction points of contacts on the surface, separated by distance between 0.25 mm and 0.05 mm. Two diodes were thus placed so close together that the events in one

³¹²⁷ Kramer (1997, 1205) dated the invention on 16. 12. 1947, just like Holonyak, 1992 39; Bondyopadhyay, 1998, 63.

of them affected its neighbor. A triangular layer was cut from the polystyrene with a small narrow and straight end while they attached a thin gold leaf to it. Brattain cut a sheet of paper through a pole to the height of the triangle and attached it to the germanium. A part of the golden leaf was used as an emitter and the other part as a collector. The junction point contacts were made of tungsten also from phosphor bronze.

When they approached the junction ~~point~~ contacts to each other and pressed the DC voltage, they received mutual influences that enabled the amplification of alternating current signals. A small positive voltage on the emitter caused the electrical current of several milliamps. A sufficiently high voltage was applied on the collector to obtain a collector current of the same or larger order of magnitude from the emitter current. The collector voltage had such a sign that it attracted the holes from the emitter, so that a large part of the emitters flowed towards the collector. The collector inhibited the flow of electrons into a semiconductor, but the current of the holes (gaps) at the contact junction point was only a bit hindered. If they then changed the emitter current with the signal voltage, they received corresponding changes in the collector current. The electrical current from the emitter to the collector could change the normal flow from the base to the collector so that the change in the collector current was greater than the change in the emitter current.

Bardeen and Brattain investigated the nature of the additional conductivity of the transistor by measuring the potential near the contact at the level of the surface of the thick germanium base n-type, which was prepared in the same way as for use in high-voltage rectifiers. In the tests, the surface was first grinded and etched milled and finally oxidized in an air at 500°C for one hour. In the other tests, the upper surface was additionally anodically oxidized in the glycol borate solution, then they grinded and etched it in the ordinary manner. The rinsed oxide did not directly affect the results. Later, they discovered that surfaces could be prepared in other ways.

The change in conductivity with the changing current indicated that in addition to the ohmic conductivity, there is a different component of the additional conductivity, which is increasing with

the increasing current. It was attributed to the increasing concentration of carriers (holes and electrons) near the point with increasing current. It has been presumed that the conductive layer of the p-type may be due to the excess of impurities in the receiver near the surface or due to the closure layer in a spatial charge adequate for the raising of saturated band near the Fermi level.



Figure 28-12: Laboratory notes of demonstration of sound reinforcement with a transistor with bipolar junction (points of the contacts) on December 24, 1947

Seymour Benzer (1921 Brooklyn-2007 Pasadena) of Purdue University published the measurements of the temperature dependence of the germanium amplifier immediately after the war on 31 December 1945. He confirmed the alleged conductivity of the p-type on the surface but soon switched into molecular biology under Schrödinger's influences.

On December 24 1947 he received a hundredth-fold amplification in all spectrum of frequencies of sound (Figure 28-12).³¹²⁸ On 17 June 1948, Bardeen and Brattain patented their invention. Eight days later, they described the discovery in two letters, published in July 1948. The findings were supplemented by the simultaneously sent measurements of their chief Shockley and Pearson from Bell Labs. They used a 1 cm x 2 cm capacitor from gold and a semiconductor, which was loaded

³¹²⁸ Trigg, 1978, 187, 188.

on the opposite side of the silicon plate, 0.06 mm thick. To measure the changes in conductivity, a current was flowing between two additional gold electrodes, charged at two ends of the semiconductor. The measurements on germanium were comparable to the results obtained by the older measurements of Brattain and Shockley's silicon in the previous year.³¹²⁹

28.2.7 FET Transistors

Shockley was the head of a research group in which Bardeen and Brattain discovered a bipolar junction transistor (with points contact) after a series of experiments (Fig. 28-13). The discovery, however, was based on Shockley's idea, but he was not directly involved in experiments. This was surely annoying, and in the following months, he closely followed the research of his colleagues, more than it is usually in groups of creative scientists. He felt that the Nobel Prize could slip away from his pockets. With all his might, he threw himself into researching a field-effect transistor, whose version called JFET³¹³⁰ he developed until 23 January 1948, thirty-eight days after the discovery of Bardeen and Brattain. The invention was patented on June 26, 1948 and September 24, 1948 (Figure 28-14).³¹³¹ Shockley wanted to have a bulk effect involved and he did it, while Bardeen wanted the changed junction in the first place and he designed his transistor in his ways.

The operation of the new Shockley's transistor version was easier to follow with the theory, its noise was lower, and it could have used more power. Therefore, it soon displaced the bipolar junction transistor (with dot contact points). Soon after the Bell Labs, the junction transistor was produced in a similar form, but with different mechanical details by GE's research laboratory, followed by RCA, Raytheon and Sylvania in 1949.³¹³²

The theory of the transistor brought a new challenge to the physicists. The operation of the vacuum cathode ray tube was already part of the standard knowledge of an electrician in the mid-1950s, while the motion of particles in the solid

state was a significant novelty. Anyway, the processes in the solid state are more complex. The properties of the cathode ray tube depend only on the geometry and on the outer boundary conditions, while the properties of the solids also affected the transistor. In the cathode ray tube, we are dealing only with the motion of electrons in an electric field, but in the semiconductor, besides the electrons, there are quasiparticle electrons holes as the kind of gaps. Therefore, it is understandable that early researchers of the transistor initially differently explained phenomena involved in it. At least partly, the discovery of the industrially usable transistor preceded its full theory.



Figure 28-13: Shockley, Brattain and Bardeen at Bell Labs in 1947 upon receiving the Nobel Prize in 1956 or at the 25th anniversary of the invention of Transistor in 1972³¹³³

Bardeen attributed the success of the experiments with electrolyte to the presence of a modified semiconductor layer on the surface that limited the electron flow. However, such an explanation became doubtful when they began to produce good transistors with a surface produced by leveling a high counter voltage, provided that the collector contact was made electrically.

³¹²⁹ Shockley, Pearson, 1948, 232–233.

³¹³⁰ Junction Field Effect Transistor.

³¹³¹ Kramer, 1997 1205.

³¹³² Kramer, 1997, 1204; Trigg, 1978, 178.

³¹³³ Lubkin, Physics Today 45 (April 1992) 24–25.

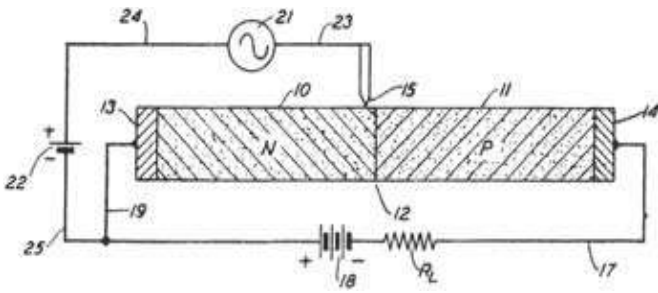

Figure 28-14: Shockley Transistor Pattern from Patent Filed on September 24, 1948³¹³⁴

William Bradford Shockley was born in London in the family of a wealthy American mining engineer. He graduated at Caltech in 1932 and received his doctorate at MIT in 1936 with Slater, who founded quantum mechanics together with Bohr in the mid-1920s. In 1936, Shockley came to Bell Labs. There he hoped to work with Davisson, who received the Nobel Prize in Physics for the study of interference of reflected electrons on a crystal in the following year. During the war, Shockley was involved in applied research, and after the war, he became the head of a new research department of solid state. He also included Bardeen, whom he met in the Cambridge in mid-1930s. In 1955, Shockley became the Director of the Arms Development Research Group at the US Department of Defense and founded his own transistor company. In 1963, he became a professor of engineering at Stanford University.

In contrast to Bardeen, Shockley (23 January 1948) and Shive independently of him assumed that the modified surface layer had no important decisive role to play. They considered the transistor rectification as primarily bulk and not surface phenomenon. In February 1948, Shive proved his assumption with an experiment. The emitter and collector junctions (points) were switched on opposite sides of the 0.01 mm thin layer of germanium and thus produced a transistor effect comparable to the transistors of Bardeen and Brattain. In 1839, a century before the regulation of conductivity with a transistor effect, E. Becquerel first observed that light is causing electrical current in some electrolytes, since the illumination increases the conductivity of the semiconductor.

³¹³⁴ Shockley, 1988, 34.

The changed theory reflected the different conditions in which Shockley's transistor operated. Unlike Bardeen-Brattain's, where the rectifying emerges at contact between the metal conductor and the germanium, in Shockley's pnp-transistor the rectification occurred inside the crystal of germanium.

The current ran primarily due to diffusion, rather than because of the electric field. In a simplified model, Shockley assumed that:

- 1) donors and acceptors were completely ionized, which holds good for germanium at room temperature,
- 2) the density of minority charge carriers is much lower than the density of majority charge carriers in each area,
- 3) the total recombination ratio in each region linearly depends on the irregularity of the density of the minority charge carriers according to its value in thermal equilibrium,
- 4) the spatial charge is not important except in the pn-contacts itself.

The behavior of his semiconductor device seemed like the vacuum cathode ray tube to Shockley. The analogy was nearly the same for Braun half of a century earlier.

The area of the emitter should correspond to the cathodes of the cathode ray tube, the base area around the grid conductors and the collector area was like the anodes. A transistor with a grounded emitter region and a signal facing the base operated as a triode with grounded cathode.

Both the transistor and the cathode ray tube are controlled by the interaction between two forms of currents of electrons. In the cathode ray tube, the grid voltage determines the flow of electrons from the cathode to the anode. In the transistor, the electrical current of holes in the base changes the voltage between the base and the emitter and regulates the flow of electrons through the base layer.

The analogy between transistors and cathode ray tubes was very human approach as both fulfilled the same industrial needs. People always prefer such analogies, like Edison who copied his own design of the bulb by gas lightning. But, in both cases the analogy is just in the appearance because the principles of physics involved are quite different in the case of earlier technology

compared to its newly designed replacement. But Bardeen did not support any analogy with a vacuum tube from his very beginning. It is precisely because of this that he introduced the emitter, collector and base fluxes as the terms still used today.

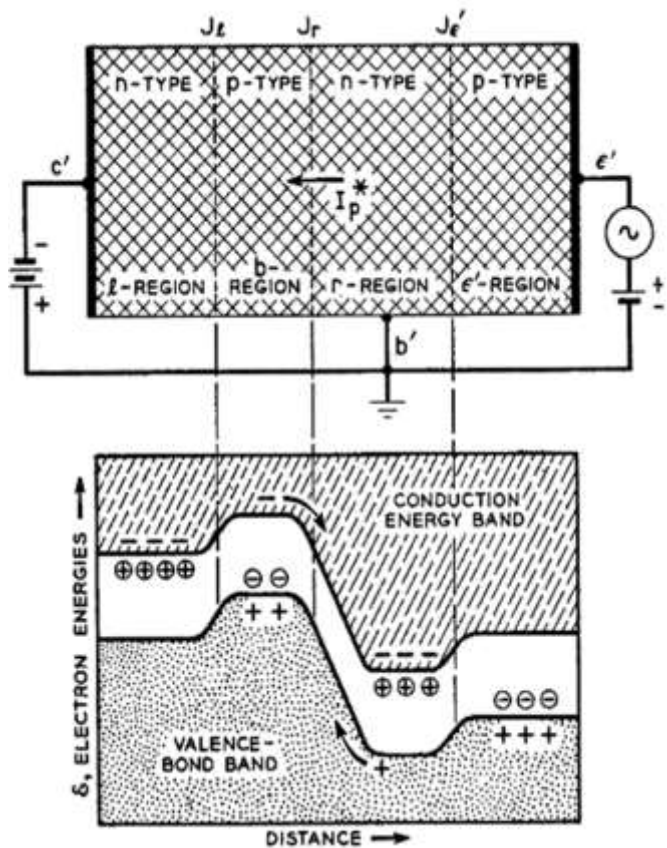

Figure 28-15: A pnp-transistor from Shockley's 1951 paper³¹³⁵

Shockley research group used a monocrystalline germanium with a p-type layer interposed between two n-type areas. The transistor worked evenly on the surfaces of pn-contacts. The size of its active surface could have changed greatly, which was not possible with point-contact Bardeen-Brattain's point-contact transistor. Thus, Shockley could increase output without increasing current. One of the greater npn transistors he presented in June and July 1950 had a contact surface of 30 mm², a base of thickness about 0.7 mm and gave 2.0 W of undeformed power at the output. Even in smaller devices with a contact surface of about 1 mm², all the characteristics of the Bardeen-Brattain's point-contact transistor were improved by several orders of magnitude (Figure 28-15).³¹³⁶

³¹³⁵ Shockley, Sparks, Teal, 1951, 157.

³¹³⁶ Holonyak, 1992, 40.



Figure 28-16: A copy of the New York Times article with the first transistor reference.

On July 1, 1948, the New York Times reported the discovery of a transistor among radio news (Figure 28-16). A few months later, Bell Labs published more detailed physical principles and electrical properties of the device.

In 1948 in Bell Labs Gordon Kidd Teal (1907 Dallas-2003 Dallas) and John B. Little developed the technology of growth of large germanium mono-crystals, in which the interior could detect and recognize the charge carriers inserted after the contact with the metal. In April 1950, Shockley, Morgan Sparks and Teal grew a crystal that had a thin layer of p-type on the n-type material. Only then the production of npn and pnp transistors started to provide nowadays indispensable parts of each microchip. In 1949 and 1954, Shockley patented devices for implanting ions into

semiconductors. After Ohl's implantation of helium ions into semiconductors in 1952, Shockley and others continued the study of solid-state bombarding of ions began in the efforts of Rutherford, Royds and Bohr in 1909. But there was one important change: the new generation of researchers this time directly worked for the needs of the industry.³¹³⁷ They even worked at better paid posts in the industrial labs and not anymore in the academic university posts. The huge Manhattan project changed everything, especially in the USA. The times changed, and the great money needed for experimental research was available only in industrial networks.

28.2.8 *Priority Problem*

The invention of the transistor was the result of the collective work of Bell Labs (Figure 28-17). The US Navy initially embraced the priority of their own researchers, but their effort was soon abandoned. The problem of priority further eased Bardeen's characteristic that he acknowledged even the small merit of his predecessors. On June 6, 1948, he thanked Shockley for "... the initiative and running of a research program that led to the discovery ...". In December 1950, Bill Shockley wrote a dedication in his new book: "John Bardeen, who made such a book needed." In the foreword, Bardeen and Brattain were quoted as inventors of a transistor. However, Bardeen's and Shockley's admirers were nevertheless discussing the priorities that are still unresolved today. Some researchers believe that Bardeen had already known the concept of injecting minor carrier in the transistor on 17 December 1947, and that Shockley only embraced it more than a month later. Bardeen and Shockley's joint research path separated when they left Bell Labs one after another in the first half of the 1950s and continued their careers in such diverse directions as research of superconductors at the university and the commercialization of transistors in the San Francisco Bay area. They were no longer involved in any joint research after their Nobel Prize in 1956, so Bardeen even avoided writing an obituary to his former chief, Shockley, in August 1989.³¹³⁸ From 1951 to 1975 Bardeen taught at the University of Illinois at Urbana-Champaign and later became professor

emeritus there. Bardeen's longtime golf partner at the Champaign Country Club in Illinois once asked him: "Say John, you know I've been meaning to ask you. Just what is it you do for living?" If anything, anyway.



Figure 28-17: Bell Labs in Murray Hill, New Jersey in 1950³¹³⁹

28.2.9 *"Silicon Valley" and Research of Scientists in Industrial Laboratories*

In September 1955, Shockley left Bell Labs and personally began commercializing his inventions of a transistor. He followed the example of Edison's three-fourths of a century older case of the production of incandescent bulbs in Menlo Park. Shockley set up transistor laboratories in his native Palo Alto, California, and headed them until August 1963. This led directly to the emergence of the silicon transistor industry in my native San Francisco Bay Area, later fortunately nicknamed as the Silicon Valley.

The center of development has moved from the eastern to the western coast of the US, where the most important researchers of the transistor were at home.

The industry, which grew from the invention of the transistor, promises a lot. The computers were their very best chance, as the transistor elements largely solved the problem of overheating, slowness and, basically, the oversize of the first computers with tubes which began to assemble just before the invention of the transistor. The modern computers

³¹³⁷ Yarling, 2000, 1746.

³¹³⁸ Holonyak, 1992, 39. Bondyopadhyay published his opposite opinion (1998, 196, 207).

³¹³⁹ Ehrenreich, 1995, 33.

and semiconductor switches were born almost simultaneously, quickly married in their early ages, and absolutely ruled the world ever since, unchallenged except for the futuristic quantum computers.

The great race began. The Raytheon of Vannevar Bush and his friends was one of thirty-five companies which learned FET technology Transistors at the Bell Labs symposium in April 1952. In March 1953, Raytheon produced 1000 germanium transistors per month at a price of \$ 9 per piece. By 1957, the Raytheon controlled the market, but then stayed behind in the development of technology. In the mid-1950s, when the transistor according to Shockley's idea was still largely an "improved cathode ray tube", the production of transistors still yielded twenty times less income than the production of cathode ray tubes. The profits of both industries have become comparable only in the early 1960s, when the US government, following the success of Russia's Sputnik on September 4, 1957, began generously promoting the miniaturization of transistors in fear of technological lag.

The role of scientist Shockley in the production of transistors was the fruit of the half of a century of the coexistence of academically educated scientists and industry in highly developed Western societies which culminated in Manhattan project. The successful operation of industrial scientists began with the chemist educated at Yale university Charles Benjamin Dudley (1842 Oxford, New York-1909 Pennsylvania), who organized a laboratory for the testing of materials with thirty chemists at Pennsylvania Railroad from 1875 to 1905. The scientists have been particularly successful in developing of bulbs, as the physicists Edward Leamington Nichols (1854-1937 West Palm Beach) and Upton have greatest credit for Edison's success. Similar tasks were performed by John Stone (1869 Virginia-1943 San Diego) who grew up in Cairo and George Campbell in Bell's telephone systems, where after his studies in Vienna, Berlin, Leipzig and Gottingen the professor of physics William White Jacques (1855 Haverhill, Massachusetts-1932) of MIT researched as an expert at the department for electricity and patents in 1880-1897. Between 1885 and 1911 they had Hammond V. Hayes borrowed from MIT, and from April 1911 onwards there was a special research team in Bell labs led by Edwin Colpitts (1872-1949).

So, Bell Labs already had a rich scientific tradition upon Shockley's arrival. Scientists no longer relied for a single industry survey, as academically trained researchers rather became permanent developers in specific laboratories. The novelty was first introduced by the chemical company Bayer, where the chemist Duisberg, who has received his Ph.D. in Jena,³¹⁴⁰ has been studying new colors since 1884. In 1889, they decided to include him in a new major scientific laboratory, which opened in August 1891, and the Patent Office was added to it six years later. New developments in Bayer began to promote modern science-industry relationships, which were soon adopted by British chemical companies and the electrical engineering industry.

The American companies were particularly influenced by the experimental electrochemical laboratory, which was set up by GE in the spring of 1900, after Steinmetz's long-term efforts. Since 1890, Steinmetz has been researching in GE's calculating department and has been aware of the progress in Europe. Nevertheless, Steinmetz failed to separate the laboratory from the factory completely, as his lab had to provide the marketspace for his factory.

28.2.10 Application of Ion Implantation in the Semiconductor Industry

The ion implantation is a seemingly tough process, but with full electronic control, it enables embedding specific ions into the desired parts of the substrate. The already made procedure was welcomed into the new-born semiconductor industry.

At the same time, at the beginning of development of ion implantation in the laboratories, many accelerators and separators were available, which due to their low energy capacities were no longer used seriously in nuclear physics. In many aspects, the rapid growth of ion implantation was a child of Manhattan project. The rapid growth of the extremely optimistic Gordon Earle Moore's Law was an inevitable consequence of matching happy circumstances. In course of three decades, ion implantation has become a mature form of

³¹⁴⁰ Fox, Guagnini, 1999, 255; Schopman, 1988, 142.

technology, and today its use in the semiconductor industry is expanding elsewhere.

28.2.11 Transistor and the Beginnings of the Use of Ion Implantation in Semiconductors

The single vacuum process used in the production of the first transistors and integrated circuits was the chemical vapor deposition of aluminium and gold contact layers from a hot vanadium conductor. In the following years, more reports have been published about the bombarding of semiconductors with ions, but nobody had compiled any working devices.³¹⁴¹

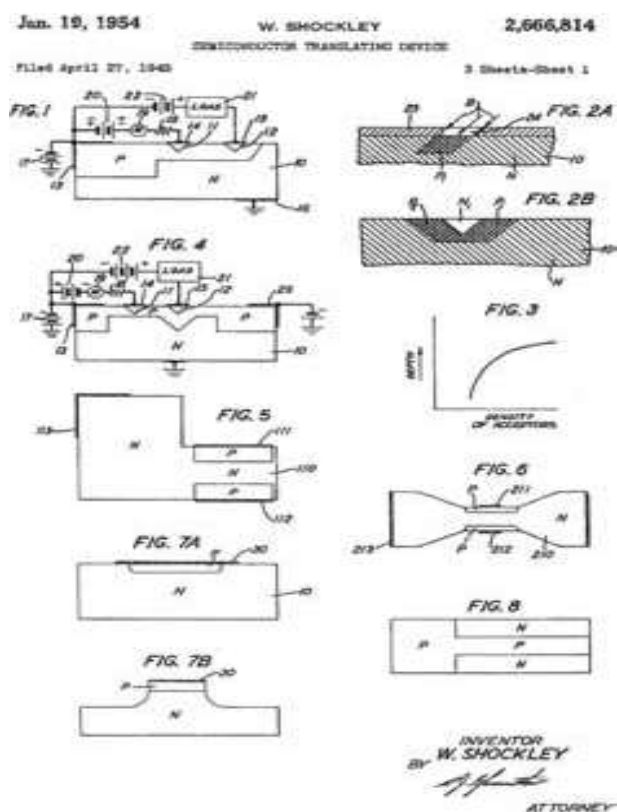

Figure 28-18: Shockley's idea for the manufacture of a pn-contact with ionic bombardment in U.S. Pat. 2666814, endorsed on 19. 1. 1954.³¹⁴²

On 27 April 1949, Shockley filed a patent for a semiconductor translation device. He described the production of the pn-contact of a separate JFET-transistor using ion implantation. He suggested

bombarding of a semiconductor with deuterons and α rays (Figure 28-18).³¹⁴³

On 31 January 1950 Ohl submitted the first patent for the bombardment by oxygen, hydrogen, nitrogen, helium, argon, CO, and even CHCl_3 in the production of semiconductor devices. The first one described all the basic features of ion implantation. Unfortunately, he incorrectly believed that the impurity ions entered the surface layer of the crystal and changed the number of charge carriers and with it the electrical characteristics of the substance. The mistake misled the research of many people.³¹⁴⁴ Five years later, Bell Labs first used implantation of He^+ in the point-contact semiconductor diodes of junction. This improved the properties of the reverse (feedback, return) current, which was modified by the He^+ bombardment.³¹⁴⁵

On 28 October 1954, Shockley at Bell Labs filed a patent for the "formation of semiconductor devices with ionic bombardment". He described the basics of ion implantation equipment in the production of the JFET transistor.³¹⁴⁶ Although he gave only the foundation of the procedure, he also submitted the data about the ion separation before implantation and electrical and mechanical scanning. He additionally introduced the concept of the ion implantation area and identified the damage to crystalline silicon due to ion bombardment.

Shockley's patent implied the birth of successful ion implantation, which was not specifically patented since it was widely known. He was particularly interested in the invention of heating the semiconductor up to 400°C after implantation, which was necessary for removing the damage caused by the ion bombardment and for the electrical excitation of the implanted dopant. Such successes, independent of the ion implantation equipment itself, remained a characteristic of its development later.

Otherwise from Ohl who considered only surface changes, Shockley considered that the energy of

³¹⁴³ Shockley, American patent no. 2666814, 19. 1. 1954, no. 2672528, granted on 16. 3. 1954; Bondyopadhyay, 1998, 199.

³¹⁴⁴ Ohl, 1952, 104; Fair, 1998, 112.

³¹⁴⁵ Yarling, 2000, 1746.

³¹⁴⁶ Shockley, American patent no. 2787564, 2. 4. 1957, granted -accepted on 12. 4. 1958; Sah, 1988, 1285, 1288, 1321; Bondyopadhyay, 1998, 199.

³¹⁴¹ Sah, 1988, 1280–1283; Waits, 2000, 1736; Wegmann, 1981, 1.

³¹⁴² Bondyopadhyay, 1998, 199.

incident ions also determined the depth of implanted doped impurities. Thus, Ohl described the essence of ion implantation as the possibility of inserting impurities into the desired location in the semiconductor. The east coasters were not defeated easily by Silicon Valley as James W. Moyer at GE in Schenectady, New York had filed similar patent four months before Shockley. However, Moyer's patent was only validated 15 months after Shockley's patent when the use of beams of ions had already become domesticized in the manufacture of pn junctions and transistors.

In 1955, W.D. Cussins from the former Rutherford's Cambridge reported the first semiconductor doping by implantation. He doped a dozen different dopant elements into germanium. The following year Ohl got the first patent for the basics of ion implantation.³¹⁴⁷ Later he patented the first solar cell.

28.2.12 Integrated Circuits

During the first decade after the invention of the transistor, pn-contacts were made by diffusion of doping elements. In parallel, semiconductor researchers thought of an integrated circuit because the possibilities for miniaturization were at hand and the needs of the space industry were enormous. On 25 April 1956, Shockley filed a patent for a "semiconductor mobile register" after leaving Bell Labs. This was the beginning of the development of monolithic integrated circuits (Figure 28-20).³¹⁴⁸



Figure 28-19: First Kilby Integrated Circuit for Texas Instruments (TI)³¹⁴⁹

³¹⁴⁷ Wegmann, 1981, 1, Fair, 1998, 112–114.

³¹⁴⁸ Shockley, American patent no. 2967952, 10. 1. 1961;

Bondyopadhyay, 1998, 204.

³¹⁴⁹ Ross, 1998, 23.

Kilby successfully invented the integrated circuit in July 1958. He placed the resistors, capacitors and diodes made of germanium on a common basis. Next month, Kilby compiled a simplified version of the circuit, and he showed the operation of the first simple microchip on September 2, 1958. On 6 February 1959 he filed a patent called "Miniaturized Electronic Circuits" for depositing an Aluminium layer on a layer of SiO₂. He knew that his invention would be important for electronics, but he could not think about the extent to which reduced prices of transistors would accelerate its development. His semiconductor microchip (microarray of integrated circuit) was a bit cumbersome and expensive to produce (Figure 28-19).³¹⁵⁰

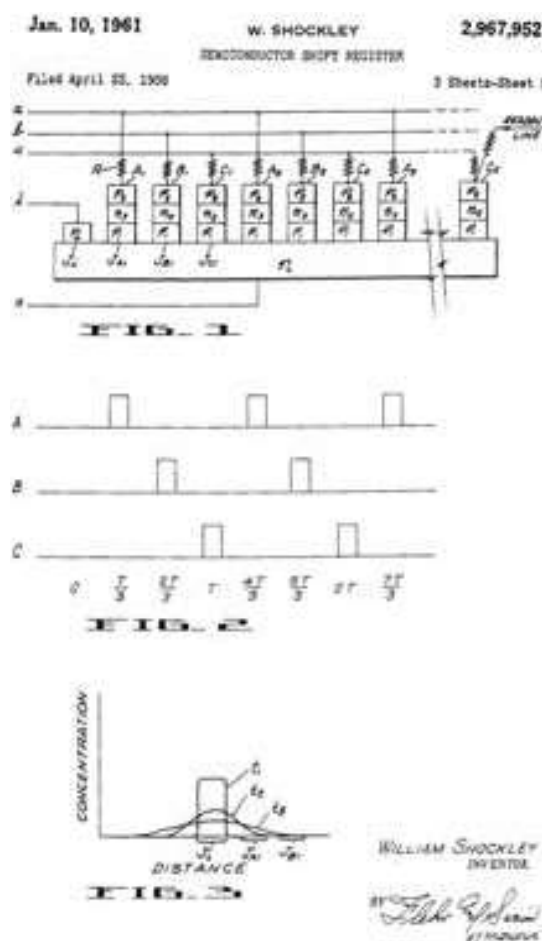

Figure 28-20: Shockley Patent for a "Semiconductor Moving Register" filed on 25 April 1956³¹⁵¹

³¹⁵⁰ Kilby, 1976, 653.

³¹⁵¹ Bondyopadhyay, 1998, 208–210.



Figure 28-21: Photo of the Fairchild Semiconductor building in Palo Alto, California, with a memorial plaque dedicated to Noyce's invention³¹⁵²

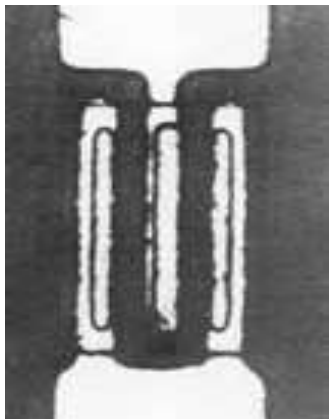

Figure 28-22: Microphotography of the first planar transistor according to Hoerni's invention at Fairchild³¹⁵³

That was a time of Soviet success with the Sputnik on September 4, 1957, when the US government invested enormous resources in miniaturization. Therefore, it is not surprising that the idea for a different version of the integrated circuit was independently developed by physicist Noyce in January 1959.

A week after Sputnik, Noyce and eight other researchers of different disciplines left Shockley's semiconductor laboratories after a year and a half. They founded Fairchild, just a mile away with the support of Fairchild Camera and Instrument Corporation. The original aim of Fairchild was the development, manufacture and sale of double-diffused silicon transistors without the use of ion implantation. After a few months, the first success occurred when the theoretical physicist Hoerni

invented the process of making a planar transistor to avoid impurities. However, those ideas were not immediately used.

Jack StClair Kilby of Missouri spent his childhood in neighboring Kansas. Already in his youth, he helped his father who was an electrical engineer. In 1941 he began his studies at the University of Illinois. He graduated only after the war and achieved his master's degree as electronics engineer in Wisconsin in 1950. In 1947 he began to develop electronic devices in the Semiconductor Department of the Globe Union Inc. Centralab in Milwaukee. He became acquainted with transistors primarily by the lectures at Bell Labs. In May 1958, he joined the TI. Since 1952, TI Semiconductor Laboratory has been led by G. K. Teal, who came from Bell Labs, where he was involved in the development of the technology of large crystals of germanium in 1948. Between 1965 and 14 April 1971, Kilby developed the first pocket computer. In November 1970, he became an independent inventor. Among other things, he was researching solar cells. Between 1978 and 1984 he was a professor of electrical engineering at A & M University in Texas. In 1982, he was placed in the "honor room" alongside Edison and other American inventors, whom Noyce also joined in the following year. In 1989, both researchers received the first NAE Charles Stark Draper Prize for Engineering that was equivalent to the Nobel Prize for inventors. Kilby received half of the Nobel Prize in Physics for his "share of the invention of integrated circuits". The other half of the prize was shared by Zhores Ivanovič Alferov (Жорѣс Ива́нович Алфѣров, 1930 Vitebsk- 2019 Saint Petersburg) of the Petersburg Institute of Physics and Technology and Professor Herbert Krömer (Kroemer, * 1928 Weimar) from the University of California, Santa Barbara, for "the development of semiconductor heterostructures used in high-speed and optical electronics." They developed the semiconductor superlattice

idea, first published by the Japanese Leo Esaki (江崎 玲於奈, Reona, * 1925 Osaka) and the Chinese Raphael Tsu (* 1931 Shanghai) for USA IBM in 1970. Krömer was the first to use heterostructures in crystalline transistors and crystalline lasers, and Alferov compiled the first laser with GaAs-heterostructure. In the mid-1950s Krömer tried to increase the speed of transistor devices, and in the last decade of the

³¹⁵² Moore, 1998, 55.

³¹⁵³ Moore, 1998, 58.

twentieth century heterostructures became a key component of solid state electronics without which there would be no modern CDs.

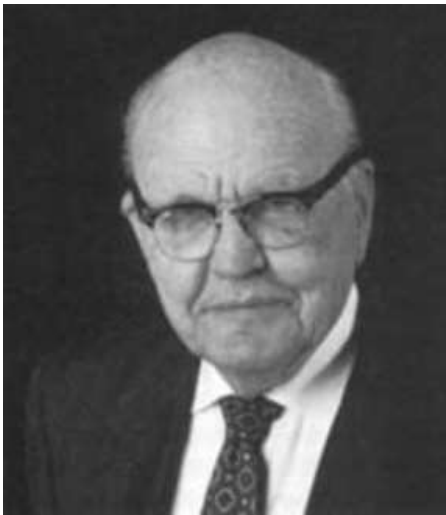

Jack StClair Kilby (* 1923; † 2005)³¹⁵⁴

Noyce was the only one in Fairchild who had experience with semiconductor research, mostly with germanium, before their research at Shockley's company. At the initiative of the Patent Office, he organized the meeting of the leading technical researchers as Fairchild research and development director (Figure 28-21). He explained to them how Hoerni's idea could be used to produce complete circuits, and not just individual components by printing a plate using lithography.³¹⁵⁵ On July 30, 1959, Noyce filed a patent for a "semiconductor device and rectifier" describing a planar integrated circuit and using Hoerni's ideas. The circuits have been replaced by the implantation of aluminium. In August 1959 Fairchild announced to the public that they would begin to produce transistors according to Hoerni's new planar procedure. The group led by the member of Hoerni, Moore and Noyce's traitorous eight betraying Shockley the physicist Jay T. Last (* 1929 Pennsylvania) made the first planar integrated circuit at Fairchild the same year (Figures 28-22 and 28-23).³¹⁵⁶

Production started next year. In May 1961, President John F. Kennedy announced the Apollo program. At the end of the year, they introduced

³¹⁵⁴ Hellemans, 2000, 29.

³¹⁵⁵ Hoerni, 1961, 178; Moore, 1998, 53, 58–59.

³¹⁵⁶ Noyce, American patent no. 2981877, granted-accepted on 25. 4. 1961; Yarling, 2000, 1747; Ross, 1998, 22–23; 93; Sah, 1988, 1292.

the first four integrated circuits Micrologic™, which consisted of five basic logic functions. Those were mainly bought by the army. The computer that Apollo took to the moon had some parts from the Micrologic family of circuits.³¹⁵⁷

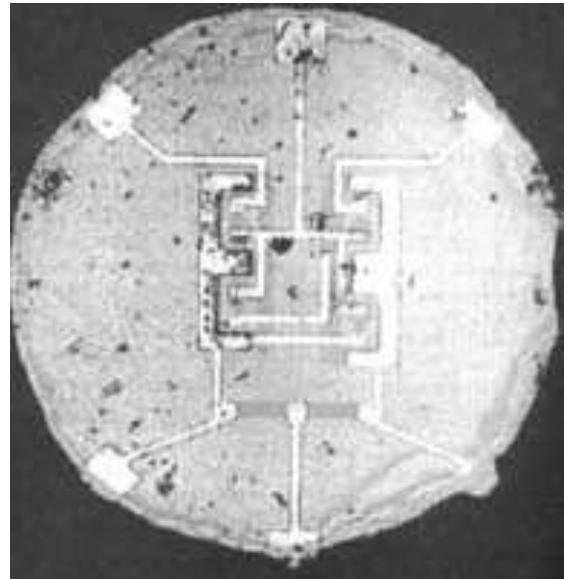

Figure 28-23: Microphotographs of the first planar integrated circuit, which were developed by Noyce's invention at Fairchild³¹⁵⁸

However, there was no way without a dispute on priorities. Noyce received a patent before Hoerni and Kilby and was initially proclaimed as the inventor. However, the longstanding dispute between Fairchild and TI ended with an agreement in 1966, so Noyce and Kilby shared a priority in the invention of the integrated circuit.³¹⁵⁹

In June 1960, the Korean Dawon Kahng (1931 Seoul-1992 New Jersey) and the Egyptian Mohamed Mohamed Atalla (محمد محمد عطالله; 1924 Bur Sa'īd (Port Said)–2009 California) of Bell Labs published a description of the MOS transistor that realized the ideas of the transistor invention of 1947. In 1964, RCA first used MOS technology to produce integrated circuits.³¹⁶⁰

Despite of the obvious success of integrated circuits, due to some doubts few types of "molecular electronics" were parallely developed for at least five years, for example, in the US Air

³¹⁵⁷ Waits, 2000, 1738; Moore, 1998, 59.

³¹⁵⁸ Moore, 1998, 60.

³¹⁵⁹ Yarling, 2000, 1746–1747; Ross, 1998, 22; Fair, 1998, 111, 119; Bondyopadhyay, 1998, 204.

³¹⁶⁰ Moore, 1998, 60–61; Ross, 1998, 24; Sah, 1988, 1293

Robert N. Noyce was the son of a Protestant priest from Iowa. Bardeen's classmate from the University Grant, Oscar Gale (1903-1998), was Noyce's professor of physics at Grinnell College in Iowa. Gale impressed him with physics and mathematics, introduced him to transistors, and saved Noyce from punishment after Noyce stole a pig from a mayor's farm. Noyce received his doctorate in 1953 at the MIT and joined Philco Corporation in Philadelphia to develop transistors. In January 1956, after Shockley's invitation, he was employed in semiconductor laboratories in Palo Alto. As usual in the Silicon Valley, Noyce often took part in setting up new businesses. In September 1957 he co-founded Fairchild, in July 1968 Intel, and finally Sematech.



Robert N. Noyce (* 1927; † 1990)³¹⁶¹

Force and in Bell Labs. In the Bell Labs, they established an ion implantation group only in the mid-1960s, a decade after Shockley's patent, after researchers of ion implantation stimulated the search for new applications of outdated accelerators and mass separators that were replaced by nuclear physicists by their devices with higher energy performance. Thus, research equipment for ion implantation has already been available in Chalk River Nuclear Laboratories, Oak Ridge National Laboratories, AERE Harwell at Oxfordshire UK and elsewhere. However, accelerators with high energies of the MeV range and small currents were not particularly suitable

³¹⁶¹ Bondyopadhyay, 1998, 204.

for ion implantation, and initially they directed research to ordinary temperatures, at most up to a few hundred degrees Celsius, where no real possibility of a new method of doping has been shown yet.³¹⁶²

The Chinese **Chin-Tang Sah** arrived in the United States in 1949 and in 1953 he listened to Bardeen's lectures on transistors at the University of Illinois in Urbana. Sah collaborated with Noyce in Shockley's Transistor Laboratory and in Fairchild since 1959. Sah led a physics department with sixty-four to sixty-five associates and developed a large part of the first generation of silicon integrated circuits until 1964. In 1962/63, Bardeen intervened to enable Sah's chair of electrical engineering and physics at the University of Illinois at Urbana-Champaign.³¹⁶³

In 1960, a small Danish company for the accelerators called Danfysik produced the first industrial implant for a Canadian state-owned research company in Ontario. The 70 keV model was called "Scandinavian". Soon, pioneering research into ion implantation at the University of Copenhagen shortly after Bohr's death enabled the Danish industry to succeed globally. Investment in fundamental science paid off relatively fast.

Almost no progress was made in the field of ion implantation from 1956 to 1961. In 1961 at Knolls Atomic Power Laboratory of GE in Schenectady, Frank M. Rourke and colleagues described ionic doping of silicon with elements of groups III or V. The concentration of the atoms 10^{18} cm^{-3} in the layer near the surface of the silicon target was obtained. Rourke's work encouraged the research by Swedes Torsten Alväger and Niels J. Hansen, who reported about the first use of semiconductor doping implants in industry in 1962. They implanted 10 kV phosphor ions in silicon crystal of p-type doped with boron, with a resistivity of $9000 \Omega \cdot \text{cm}$, by an electromagnetic isotope separator at Argonne in US. They got a junction few ten nanometers beneath the surface. After their bombardment, the product was heated to 600°C to get rid of radiation damage, but some phosphorus

³¹⁶² Wegmann, 1981, 1, Fair, 1998, 111, 114; Ross, 1998, 23; Ryssel, Ruge, 1986, 3.

³¹⁶³ Sah, 1988, 1326.

was diffused into silicon. Their detector of α particles with a 25 mm² plate was comparable to devices made by a diffusion process.

In 1947, Van de Graaff of MIT, his assistant John G. Trump, and the head of the British delegation at MIT Denis M. Robinson set up a High Voltage Engineering Company (HVEC) for production of implants. Trump first described the use of ion implantation for the treatment of cancer. HVEC researchers later set up new businesses, among them Ion Physics Corporation (IPC) for space research. In 1965, HVEC manufactured the first implant for the industry.

Around 1967, the users of ion implantation equipment had to solve the problem of optimum pumping and to choose the best installation of the pumping device at the source, the beam or the target. The implantation planners were mainly high-voltage experts and had only to learn about vacuum technology. In 1971, they founded Extrion, the first long-term successful importer. Later, the company was renamed Varian SEA and is still dominant in the market today. In addition to it, KEV, Ortec and Accelerators, Inc. were engaged in ion implantation in the United States in 1971, while in England Linott Inc. excelled and later joined Applied Materials.³¹⁶⁴

28.2.13 Ion Implantation at Higher Temperatures

On the 1967 conference in Aarhus (Århus) in Denmark, Kenneth E. Manchester (Ken, 1925 Winona, Minnesota-2014) of Sprague Electric Co., North Adams, Mass. and colleagues reported on the first bipolar transistor, made exclusively with electron and ion jets. The new advanced technology was already called "ion implantation" in the title of their discussion (Figure 28-24).³¹⁶⁵ The prosperous baby was born long ago, but its godparents somehow delayed its baptism for decades.

At the same conference W.J. King from the Illinois based firm Institute of Printed Circuits (IPC) established in 1957 announced the possibility of

predicting the depth of implanted contacts and the use of higher temperatures that just opened the right possibilities of ion implantation. King's proposals conflicted the opinion of most participants. Nevertheless, King's opinion was welcomed since King was no newcomer after he observed three years earlier the implantation of phosphorus and other elements of V- and III groups with accelerating energies of 1 MeV in solar cells. His research followed a year older Alväger and Hanson's implantation of phosphorus ions in silicon for production of nuclear radiation detectors, while King already used the term "ion implantation."

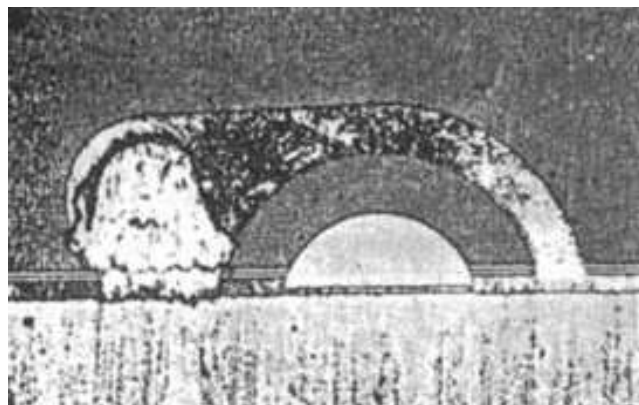

Figure 28-24: The first bipolar transistor produced by the ion implantation technique by Manchester's group in 1965³¹⁶⁶

King's group used Van de Graaff's generator to accelerate spectroscopically pure ions of ¹¹B and ³¹P with the voltages between 80 keV and 400 keV. By currents 1 μ A to 10 μ A they obtained n- and p-type layers in semiconductor substances of group IV, especially in silicon. The high voltages reduced sputtering so that they made their contacts at the usable depth without the "channeling" process along the selected crystal surfaces. In the first half of the 1960s, IPCs produced solar cells with their surfaces of 2 cm², radiation detectors 1.25 cm in diameter, spectrometers, magnetic spectrographs, unipolar (FET) and bipolar transistors. The diodes were also tested with the production of the n-type layer after the implantation of the ³¹P in the diamond. King's process provided a good control of the density of implanted ions between 10¹⁴ cm⁻³ and 10²⁰ cm⁻³ in a repeatable manner. The ions of high energies were implanted through the passive protective layer of SiO₂.

³¹⁶⁴ Waits, 2000, 1741, 1744; Fair, 1998, 115.

³¹⁶⁵ Yarling, Johnson, Keenan, Larson, 1991, 57; Fair, 1998, 117-118.

³¹⁶⁶ Fair, 1998, 118.

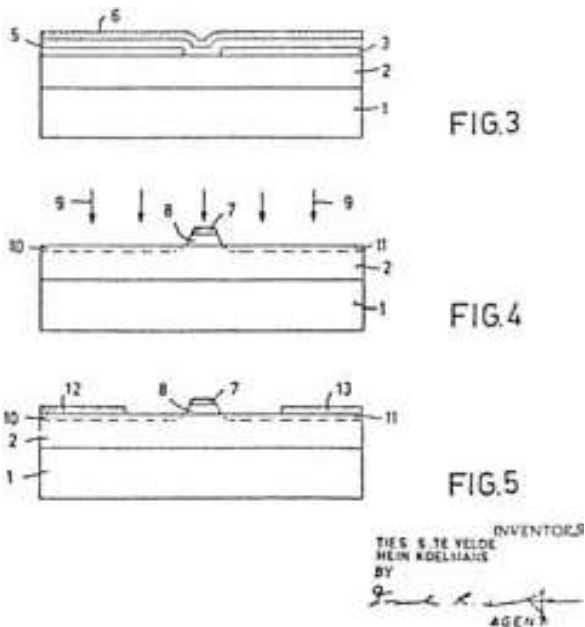

Figure 28-25: TS de Velde's self-aligned MOSFET gate made for Philips in 1966³¹⁶⁷

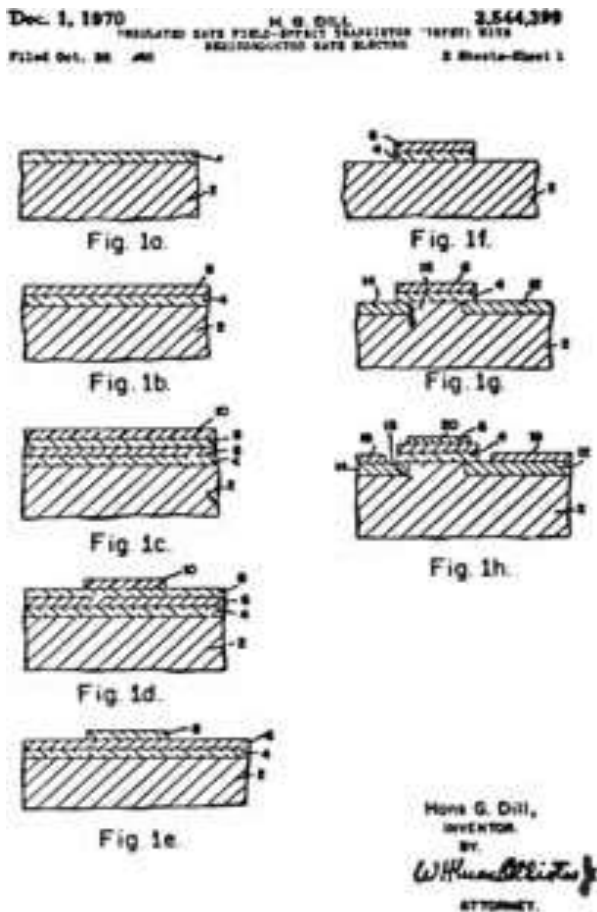

Figure 28-26: H. Dill's "self-aligned" MOSFET gate made at Hughes Aircraft Company in 1966³¹⁶⁸

Since the temperatures used were below the diffusion temperatures, different devices or elements could be produced in one piece without any interaction events, including the npn and pnp transistors. This prevented the diffusion of unwanted impurities. The temperature of the substrate was controlled between -195°C and $+800^{\circ}\text{C}$. At ion concentrations up to 10^{18} cm^{-3} all the ions were used for substitution, and at a hundred times higher concentration, the number of useful ions fell to 50%. The concentration was calculated according to the LSS theory of Lindhard, Scharff and Schiøtt. The difference between theory and measurements was below 10%. For most distributions and resistances of the silicon target, only the highest implanting energy determined the depth of contact.³¹⁶⁹

King's initiative enabled the invention of self-aligned MOSFET-gates. In the comparatively short dozen months period different able groups of researchers in the Netherlands and the US succeeded in their production. They've got the same results while solving various problems. On June 1, 1964, H.A. Klasens' group at Philips patented and in the same year published an improved procedure for production of a thin-film transistor. The gates for automatic control of the source and outflow area were used for the first time. Two years later, Ties Siebalt (Ties Siebolt) Te Velde invented the use of the transistor gate as an anti-ion barrier in the same company Philips' US headquarters (Figure 28-25). He used the damage caused by the bombardment with ions of argon, oxygen or nitrogen ions to make a transistor in a semiconductor substrate made of sulfides or selenides of cadmium or zinc. Like in the case of sputtering, the apparent damage appeared to be benevolent as the foundation of new stage of useful devices.

At the same time, on May 1, 1966, Hans G. Dill tested polycrystalline silicon with a melting point at 1410°C for its use in high-temperature gates at Howard Hughes's (1905-1976) Aircraft Company Newport Beach in California. On 26 October 1966, he filed a patent describing the process of making self-aligned gates (Figure 28-26). The next day, his colleague, Robert W. Bower (* 1936 Santa Monica), filed a similar patent with aluminium gates made at low temperatures. R.E. Kerwin, D.L. Klein and John C. Sarace filed a patent with Bell Labs on 27 March 1967, which was technically

³¹⁶⁷ Fair, 1998, 120.

³¹⁶⁸ Fair, 1998, 121.

³¹⁶⁹ Wegmann, 1981, 5; Yarling, Johnson, Keenan, Larson, 1991, 57; Fair, 1998, 111, 115, 117-118.

equivalent to half a year older Dill's work. The San Francisco resident Boyd G. Watkins of Santa Clara General Micro-Electronics (GME) patented his invention more than a year before others, but not without errors.

The priority was attributed to Bell Labs in 1974, but various companies developed different technologies. Due to disagreement in the choice of technology, the group of engineers with Noyce and Gordon E. Moore included left Fairchild and founded Intel for the development of products based on silicon gates technology. Intel has developed the first microprocessor.³¹⁷⁰

28.2.14 *Ion Implantation as a Mature Form of Technology*

In parallel with the US, ion implantation was developed in the Soviet Union; they presented their achievements in a more popular form only after the fall of the Berlin Wall in October 1991, and triggered a great surprise; the research of ancient uses of silica in Chinese porcelain and Egyptian or Phoenician glass will provide more surprises even if the ancient silicon might be mostly the unwanted impurity of pig iron and steel productions.

Already in 1952, Ioffe's student Mikhail Mikhailovich Bredov (1916 Smela Station by Kiev-1976 Leningrad) noticed the changes in the conductivity of the p-type germanium after he bombarded it with Li^+ in the Physicochemical Institute in Leningrad. In 1961, in the Laboratory for ionic bombardment of the Institute of Atomic Energy of Kurčatov, the former Ardenne's collaborators Viktor M. Gusev (Виктор Михайлович Гусев, 1919—1978) and Marija I. Guseva (Мария Ильинична Гусева, 1925 Нежин (Nizhyn) in northern Ukraine)-2017) got pn-contact with good amplification properties after the bombarding of silicon with the ions of elements from groups III and V of the periodic table. Five years later, the technology of ion implantation was used for the first time in the Soviet Union for the mass production of switching pin diodes and bipolar transistors. The advantages of ion implantation in the production of solar cells were announced by the Gusev's group even before King's publications in the United States.³¹⁷¹

The involved amounts of implanted ions were initially determined

optically. In 1973, IBM tested them for the first time with an automatic layer resistance tester.³¹⁷² Today, we determine the amounts of implanted ions by measuring electrically doped atoms or by evaluating target damage.³¹⁷³

In 1967, in French Grenoble, the first conference was dedicated to the use of ion implantation in the semiconductor industry. In 1970 they released the first book entirely dedicated to ion implantation.³¹⁷⁴ Since then, the international conferences on these technologies regularly follow one another. The Exitron DF-4 designed in Varian's production in 1975 became the most common implant in the world two years later. With these achievements, ion implantation has become a mature form of technology developed in semiconductors. As always happens in sciences, the symposia and monographs made ion implantation a kind of an independent field of research and applications.

In the following decades, the ion implantation began to be used in other fields, especially in the metallurgy for the development of new alloys, to better understand the role of impurities in metals, to change the temperature of the phase transition of superconductors and the chemical and mechanical properties of metal surfaces. To avoid the problems of sputtering molecules from surfaces and limited concentration of implanted matter with ions, we prefer bombarding of already sputtered thin films. Thus, two vacuum technologies have been complemented, although they were developed independently until then. Certainly, they were enough close to each other that some experts were familiar with both.

The ion implantation has several advantages because it does not require increased target temperatures, allows continuous modification of the composition, does not form oxides and other barriers between thin films as other method do, allows higher reaction rates and lower temperatures than conventional metallurgical processes.³¹⁷⁵ With the possibility of precisely dosing any of the sufficiently low ion concentration in thin films, the implantation of ions

³¹⁷² IITS, (Ion Implant Test Site).

³¹⁷³ Yarling, Johnson, Keenan, Larson, 1991, 29.

³¹⁷⁴ Mayer, Eriksson, Davies, 1970.

³¹⁷⁵ Yarling, 2000, 1746–1747; Ryssel, Ruge, 1986, 3, 1–2; Dresselhaus, Kalish, 1992, 156–158.

³¹⁷⁰ Fair, 1998, 111, 119–124; Moore, 1998, 62; Waits, 2000, 1739; Sah, 1988, 1284.

³¹⁷¹ Yarling, 2000, 1750; Ryssel, Ruge, 1986, 338.

Table 28-1: The most important steps achieved during the first century of ion implantations

Year	Researcher	Place	Field of research or discovery
1891–1895	Hertz, Lenard	Bonn	Penetrability of "Cathode rays" through solid-state barriers
1904	Bragg, Kleeman	Adelaide	zone of air ionized by flight of α rays
1905–1906	Rutherford, Becquerel	Montreal, Paris	first ion implantation in research of the penetration of α rays
1908–1909	Rutherford, Royds	Manchester	published description of the first implanter in the discussion on the helium nature of the α rays
1911–1914	Rutherford and colleagues	Manchester	bombarding of solid matter with ions, discovery of the atomic nucleus
1913, 1915	Bohr	Manchester	theory of the interaction of charged particles with electrons and nuclei in targets
1948	Bohr	Copenhagen	theory of reduction of charges of charged particles during their penetration of matter
1952	Ohl	New Jersey	patent for the first use of implantation in semiconductors, confirmed in 1956
1954	Shockley	New Jersey	patent for overheating with description of ion implantation, confirmed in 1958
1958–1960	Kilby, Hoerni, Noyce	Dallas, California	patents for planar transistors and integrated circuits, granted between 1961 and 1964
1962	King and S.J. Solomon	Massachusetts	use the term "ion implantation", the creation of special research groups
1963	Lindhard, Scharff, Schiött	Copenhagen	LSS theory of the ion implantation energy field
1967	Fairchild	California	first use of ion implantation in a planar integrated circuit
1970	Mayer, Eriksson, Davies	New York	the first monograph on ion implantation
1971	Extrion company	California	Establishment of the first long-term successful company of suppliers of implants
1975–1978	Extrion company	California	DF-4 becomes the most widely used implanter

has the worthwhile future among modern nanotechnologies.

28.2.15 Conclusion

The development of ion implantation began as a laboratory specificity that Rutherford and Bohr used for measurements in support of their nuclear model of the atom. They were initially interested just in the properties of bombardment particles while the ion implantation was needed just to determine their whereabouts. The attendant phenomena in the targets were not particularly attentive during next four decades, but the experimental tools and the accompanying theory was three at hand, ready for use.

With the miniaturization of transistors for space research, the need for the use of precisely such, seemingly simple, cumbersome techniques had been demonstrated, which determines the depth of ion input to the substrate and the density with the accelerating voltage. In a few years, the newly developed technology got its name, excited the special research groups, specialized conferences, monographs, and even the prevailing implanter model emerged soon enough. In this way, ion implantation as an internal enhanced technology has opened the wide possibilities for use outside the boundaries of the semiconductor industry for which it was initially developed (Table 28-1).

The rapidly accelerated development of ion implantation has caused some of the annoying side

effects that might have been avoided with wider knowledge of the history of related technologies. An interesting parallel is clearly seen between ion implantation and an electron microscope. Both technologies used narrow jets in 1935 and thirty years later, which caused shading, reflection, dispersion and contamination. After ten years, in both technologies they opted for broader jets in 1945 and 1975. Why didn't the researchers of ion implantation learn from the experience of older researchers of the electron microscope early enough?³¹⁷⁶ Of course, this is merely an assessment of the "general after the battle".

There was certainly a generation long gap between them which prevented the same researchers to be active in both pursuits. Anyway, broader knowledge of the history of sciences closely related to their own field of vacuum technologies could save them a lot of efforts, but in that case they would not be able to pose as inventors, but only as the borrowers of old technologies for new fields. Most of the people prefer glory of invention and like to hide their borrowing from other parties, especially from the older almost forgotten ones. The borrowing is especially annoying for industrial scientists and their patents, because their originality is all that matters. Bardeen as a guy who loved to reference on his predecessors was more like an exception from the rule *perish or publish* (your seemingly original research).

28.3 Spread of Transistors to Europe

During his visit to the United States in 1911, the son of Karl Marx's first cousin the Jew Anton Frederik Philips (* 1874) was impressed by Langmuir's successful use of scientific achievements to consolidate his position on the market. He decided to follow the example of GE; therefore, he founded the *Natuurkundig Laboratorium* (Nat. Lab.) as a Scientific Research Department with a special status at Philips. In the beginning of 1914, the department was taken over by Holst. He completed his doctorate at Leyden labs of Kamerlingh-Onnes, who was then awarded the Nobel Prize for helium condensation. Under Holst's leadership, Philips researchers successfully

investigated the use of semiconductors between the two wars.

During the World War II, Philips did not perform surveys that enabled Bell Labs to master the technology of purifying and doping of germanium and silicon for use in radar. The German occupation put Philips in isolation, so that the American technology of germanium became acquainted for Philips only after the war, when H.B.G. Casimir and Henne Rinia's replacement at the post of director of the Nat. Lab. Evert Johannes Willem Verweij brought few grams of germanium by his first visit to the USA. In that way, despite of their similar names, the Germans delayed the Germanium use in Philips.

In 1949, Johannes Jacobus Asuerus Ploos van Amstel and Adrianus van Wieringen already produced polycrystalline germanium diodes with a new method, paying great attention to the purity of the material and the degree of doping. During the following six years, research has grown into a new plant that was set up in Nijmegen.

The concentration of US companies has hampered European marketing of transistors. In 1948, F. H. Stieltjes was responsible for initiating the research of transistors at Philips. After four years he was already running a group of ten researchers who developed Bell Labs point-contact transistor connections and transferred it to the Philips' development laboratory after the Bell Symposium in April 1952. Among the Philips' European competitors, the symposium was attended by the German companies Telefunken and Siemens & Halske. Collaboration was enabled by the Main Agreement of 1947, which was extended on 31 March 1952. Philips Nat. Lab. had not yet mastered the transistor technology and therefore needed the help of Bell and RCA.

At the Bell Symposium they demonstrated various methods for production of germanium crystals, but in Nijmegen they preferred to use the RCA alloys. Philips was in the hurry to prevent any initiative taken over by other companies that previously did not participate in the production of cathode ray tubes. Among such were, for example, US and Geophysical Services, later renamed Texas Instruments, where Teal from the Bell Labs took over the research facilities.

³¹⁷⁶ Ruska, 1986, 359; Wegmann, 1981, 2.

By the end of 1954, Philips had mastered the new technology that affected the whole company. First, they followed the American discovery, and then then Nat. Lab. established its own way to produce a transistor by the alloy-diffusion in solids POB (Pushed-Out-Base) which sold very well. In 1957, thirty-five researchers in Nat. Lab. have been studying semiconductors and the additional twenty other Philips' researchers were doing the same abroad. Philips has become a leading European semiconductor research company, despite its strong competitors. The American companies have established their branches in Europe, and many military orders enabled rapid development.

The Dutch universities, however, were not particularly interested in semiconductors despite frequent collaboration with Philips. That's why Philips was in a very disadvantageous position compared to Bell Labs. Although many Philips experts, along with Holst himself, occasionally lectured at the universities, Philips had to train most their semiconductors experts in their own Philips company. The situation improved in 1952 when Gerhart Wolfgang Rathenau (1911 Charlottenburg-1989 Waalre) left Philips and became the first professor of solid-state physics in the Netherlands at the University of Amsterdam.³¹⁷⁷

In the mid-1990s, Philips sold more semiconductor devices than other European companies but globally still stayed behind nine US and Japanese competitors.

28.4 Development of Transistors in Slovenian Country

The first successful transistors appeared in April 1950. However, semiconductors did not quickly penetrate to less developed countries like Slovenia. Thus, A. Wedam did not yet discuss semiconductors and transistors in his book of 1955, while in his three-year-older book, the famous Bela Krajina physicist Adlešič already promised them good future:

"... that the transistor was born as the competitor of cathode ray tube to whom in many respects, it would sooner or later succumb."³¹⁷⁸

In 1958, Lončar from the Faculty of Electrical Engineering in Zagreb published a discussion of semiconductors with his own experiments. With this, he opened the door to other researchers. So, the graduated engineer Zdravko Bendeković from the RIZ-Factory of Semiconductors (Tvornica Poluprovodnika) manufactured the first domestic silicon transistor when only SGS produced them in Europe in Milan. Nevertheless, in the late 1960s, domestic Yugoslavian researchers had less experience with transistors than with cathode ray tubes. The transistor devices were more expensive, so the integrated circuits still lacked in Yugoslavia.

In Yugoslavia, the Iskra and RR in Niš soon began to manufacture transistors, so they were already on sale in 1962. At the beginning of the 1960s, in the Semiconductor Department of the Institute of Electrical Transmissions (Elektrozveze) as the part of the concern Iskra (Spark), they developed their own germanium diodes and transistors. The technology was later transferred to Iskra Semiconductors in Trbovlje, where they switched to silicon diodes and planar technology as the basis for integrated circuits. However, the development did not go further from the domestic experiments, as it did not pay off to compete with the countries with a much larger market.

In the 1970s, the Laboratory for Microelectronics of the Faculty of Electrical Engineering used Varian-Extrion's cold cathode implant. The test circuit was made by engineer of chemistry Andrej Belič who patented some inventions together with his neighbour in Californian Sunnyvale by Santa Clara (Silicon Valley) Danilo D. Lasič (1952-2000) in the USA for their Liposome Technology, Inc. in Californian Menlo Park. Belič's ions were accelerated from 20 keV to 200 keV at 75 μ A for boron and 250 μ A for phosphorus and arsenic. The stream of ions was directed at an angle of 7°. Prior to the implantation of MOS transistors with channel p, the device was pumped to 0.03 mPa, and during work even down to 2 mPa. The concentration of the ions in dependence on the depth was determined by the sheet resistance of the implanted layer and by the threshold voltage of the MOS transistors with the channel p. After implantation, the product was tempered at 900°C.

The modern plasma technologies are used at the Faculty of Electrical Engineering in Ljubljana. In oxygen plasma, the photopolymer is removed by

³¹⁷⁷ Schopman, 1988, 162, 168–170.

³¹⁷⁸ Adlešič, 1952, 454–455, 468–469.

photo-lithographic procedures. SF₆-plasma with additives is used for the selective etching of silicon nitride, oxide and polycrystalline silicon. Similar procedures are also used for micro-processing of silicon. Plasma procedures are also used for PECVD-layers³¹⁷⁹ of silicon oxide and nitrides. The conductivity of metals (aluminium, titanium, gold, etc.) in argon plasma is used to produce conductive connections on elements.

Gordon E. Moore from my own native San Francisco studied at Berkeley and received his doctorate at Caltech in 1954. Shortly after its founding, he joined Shockley's transistor laboratories in 1956. In 1957, he founded Fairchild, where he became director of development two years later. In 1968, together with Noyce, he left Fairchild and co-founded Intel for the development and production of LSI (Large Scale Integrated Products). Intel began manufacturing semiconductor memories, and it sold most semiconductor devices among all companies in the world in the mid-1990s.



Gordon E. Moore (* 1929)³¹⁸⁰

28.5 Future of Transistors

The search for semiconductors has been intertwined throughout the various branches of science. In the period of decades of dominance of the cathode ray tubes, the semiconductors were mainly studied by metallurgists and physicists. After the invention of the transistor, the physicochemical properties of the materials used became interesting. At that time, the price became the dominant factor, so that physicists and technicians determined developmental orientations with the definitions of the required properties of the product. Finally, circuit designers took the lead in the production of integrated circuits. Changes in the transistor industry took place so rapidly that many experts could not follow them.

In 1965, the director of research and development for semiconductors Fairchild, the physical chemist Moore, attributed to transistor manufacturers doubling of the number of integrated components at the same time intervals. The claim is still valid: if the current eighteen months doubling period is maintained, we will have a transistor with a dimension of 10 nm in 2020.³¹⁸¹

Moore expected that the production of transistors in integrated circuit (chip) will exceed the number of printed letters in books. This will make the new way of communication a serious substitute of half a millennium older Gutenberg's invention. Certainly, he did not consider the possibilities of quantum computers.

³¹⁷⁹ plasma enhanced chemical vapor deposition

³¹⁸⁰ Proc. IEEE 86/1 (January 1998) 204.

³¹⁸¹ Kramer, 1997, 1206.

29 Industrial Uses of Vacuum Technologies: Crooke's Vision Materialized in Ether Full of Plasma

29.1 Early History of Research of Plasma

29.1.1 Introduction

In the spirit of the ancient Greeks, the world seemed to be made up of four (types) of matter: earth, water, air and fire. If they had aggregate states in mind, their opinion is like today's. It was Prometheus who gave fire to people and he was punished for this shame.

Over the next millennia, fire was useful and of course interesting. However, only in the second half of the 19th century, the European researchers mastered higher temperatures at high and low pressures. The exploration of high pressures was especially developed in the former Habsburg monarchy, where Natterer reached pressures of 3000-4000 bar since 1844 and successfully sold his own devices. However, plasma physics, which at the end of the 2nd millennium celebrated only the seventieth anniversary of its name, did not evolve from exploration of high pressures, but from the study of the discharge of low-pressure gases in cathode-ray tubes.

29.1.2 A Weak Plasma in a Flame

29.1.2.1 Faraday's Experiments with Flame

The research of flame became especially popular with Faraday's Christmas Lectures for Youth: "... none of these rival the brilliancy and beauty of flame. What diamond can shine like flame? It owes its lustre at night-time to the very flame shining upon it. The flame shines in darkness, but the light which the diamond has is as nothing until the flame shine upon it, when it is brilliant again..."³¹⁸²

Faraday observed the stratification of the flame projected by sunlight as a shade on white paper.³¹⁸²

In 1818 he published a physical discussion "about the flying flame" of various gases in the tube, which has prompted many further researches. In 1845, Faraday began to explore the "magnetic properties of gases". His discoveries were later supplemented by Plücker. Diamagnetism of the flame was discovered by a genuine university professor of physics in Genoa and corresponding member of the Academy of Sciences of Turin, a Piarist monk Michele Alberto Bancalari who previously taught mathematics and physics in the Nazzareno college for three years. He has ascertained diamagnetism of the flame placed between the poles of an electromagnet, where it is rejected by the axial line as soon as the magnetic field is established. Bancalari Avogadro and Hermann Kopp's specific caloric of the atom of a compound body is expressed by the sum of the specific heats of the simple atoms which form the compound atom. Bancalari's repulsion forces diminished inversely by the cubes of the distances.

Zantedeschi, a professor of physics and mathematics at Lyceum of St. Catherine in then Habsburgian Venice and a member of the Institute there published his continuations of Bancalari's research of diamagnetism. Besides Daniel's battery with ten elements with a diameter of 18 cm, he used a weak magnet that only lifted cargoes by a force of 480 N. For

this, Zantedeschi ordered in Turin a stronger cylindrical electromagnet with a 33.5 cm long iron core and a thickness of 1.5 cm, wrapped with copper conductors 33 m in length. He placed the poles of his magnet at the distance of 2.7 cm. The flame of the candle, of the oil lamp or the spiral lamp was adjusted so that the tip was four times narrower than the center. He proved that the flame directly reflects the magnet and not by an air vortex. However, Zantedeschi linked his diamagnetism of the flame to Kepler's theory of the magnetic Sun that attracts the planets; the editor of the German translation of Zantedeschi's papers, Poggendorff, made a great deal of doubt about that kind of metaphysics.

Zantedeschi sent a copy of his discussion to Arago of Parisian Royal Academy (AR) and to Faraday in London, because he knew all about Faraday's research of diamagnetism. In December 1847, Faraday added his own experiments to Zantedeschi's data and the editor Richard Taylor

³¹⁸² Faraday, 1950, 9, 10, 18.

(1781-1858) published both in *Phil. Mag.* He used a much stronger electromagnet with a cylindrical iron core of 117 cm long, 9.5 cm in diameter and the distance of 15.2 cm. The copper coil was 1326 m long with a 4.3 mm radius of conductor. He proved that the magnet affects all types of flames. He found that the warmed air and flames were more diamagnetic than cold ones, and therefore the heated air was separated from the colder air in their flow toward the pole of the magnet.

Faraday rejected Zantedeschi's complaint that Faraday supposedly attributed the magnetic properties to solids and liquids, not to gases. Bancalari's discovery convinced Faraday of the temperature dependence of diamagnetism, which he initially ascribed only in the case of gases, but not in solids and liquids. He made many comparisons between the diamagnetism of various gases depending on the temperature.³¹⁸³ Thus, Faraday upgraded Zantedeschi's description of oxygen as one of the most diamagnetic gases.³¹⁸⁴

Faraday proved that diamagnetism occurs "primarily due to the warm state of the gaseous part of the flame". After three years of recovering his health, Faraday continued his research of diamagnetism of gases at normal temperatures with the measurements in the atmosphere.

The research of flames also attracted young Braun. Between December 1877 and 1878, Braun upgraded Hittorff's (1869) study of the cathode sputtering and unipolar electrical conductivity of gases in Geissler cathode ray tube at the University of Marburg.

With measurements of "unipolarity" as the greater conductivity of flame in one direction, Braun continued the works of Herwig (1877), Hoppe, Hittorf (1869) and E. Becquerel. Braun assumed that the electric current does not move the parts of flames themselves, but the translation of electric current in flames takes place in the same way as in the liquid.³¹⁸⁵ Braun's flame alias plasma therefore resembled Stefan's hydrodynamic analogies.

³¹⁸³ Faraday, 1952, 856, 857, 858, 865.

³¹⁸⁴ Plücker, 1851, 87.

³¹⁸⁵ Braun, 1878, 441, 444.

29.1.2.2 Exploration of Weakly (Partially) Ionized Plasma of Flame at Viennese Physical Institute

A professor and assistant curator of the Mineralogical Cabinet in Vienna Grailich investigated the flames together with Edmund Weiss from Jesenik in Bohemian Silesian Sudetenland, the later director of the observatory and university professor in Vienna. They found that non-periodic sounds during burning occur when the volume changes by the penetration of hot oxygen and the flame products from the combustible tube into warmed air.³¹⁸⁶ They accepted Faraday's theory of flame, like Zoch did later in Erlangen. Zoch assumed that the flame is disappearing in higher positions and breaking the new flames. He discussed Grailich's study of changes in flame volumes, performed experiments with cigarette smoke, and concluded that all phenomena of fire were accompanied by sounds due to the rise of temperature.

Johann Zoch studied physics at the Viennese Polytechnic and at University of Erlangen in Beetz's class. Beetz taught at Erlangen between 1858 and 1868. Later, Beetz used thin films for the investigation of magnetic phenomena at Munich Polytechnic.³¹⁸⁷ In 1876-1877 the Bishop Strossmayer employed Zoch as a lecturer at the grammar school in Osijek in Slavonia. After the occupation of Bosnia and Herzegovina he became a provisional director of the new Sarajevo real grammar school in 1879. In 1882 he returned to Osijek for seven years. In 1889 he became a secondary school director in Bjelovar then served as a director of the Real Grammar school in the Croatian Petrinja until his retirement in 1908. In 1869 he published the first Slovakian textbook of secondary school physics, developed scientific terminology, encyclopedias and Croatian meteorology in Petrinja in 1891. As the director in Petrina he published among the first in Slavic languages a paper about Tesla's Electricity Transmission System in Sarajevo in 1895.

On July 14, 1859 the assistant at the Physics Institute in Vienna, later head of the Academy in

³¹⁸⁶ Grailich, Weiss, 1858, 271.

³¹⁸⁷ Rosenberger, 1890, 745; Jungnickel, McCormmach, 1986, 1: 204, 224; Höflechner, 1994, 2: 139.

29.1.3 The Fourth Physical State

Rome Blaserna and his students E. Mach and Julius Peterin studied induction. Later in summer 1860 Blaserna of Regnault's Parisian lab and Reitlinger of Vienna investigated the bright (glittering) figures in the water with its insulation between metals and isolators resembling the middle between Lichtenberg's figures and metallic phenomena. They relied on data of A. de la Rive's *Traité d'électricité (Treatise on Electricity in Theory and Practice, 1856)* and Riess. Soon afterwards on April 11, 1861, Reitlinger and his student (eleve) Luka Žerjav performed similar investigations of flame, anode sputtering and Lichtenberg's figures discovered in 1777. Reitlinger confirmed Faraday's findings about the distances for (minimal) breakdown voltage, the shape of the Lichtenberg's figures of branching electric discharges appearing on the surface or in the interior of insulating materials, and the relationship between the figures obtained in positive and negative electricity. He measured four very different gases, which allowed general conclusions.³¹⁸⁸

On 10 July 1862 in Viennese physics institute, the assistant Reitlinger and his new student (eleve) Franz Kraus reorganized Brande's experiment with the flame between isolated spheres, which were connected to the electrical device by conductors.³¹⁸⁹ In the following year, Stefan replaced Ettingshausen as an assistant director of the Viennese Institute, and thus directly supervised early plasma researchers. By funny coincidence the leading modern Slovenian researcher of plasma Matjaž Panjan works at Jožef Stefan Institute.

Faraday in London and Magnus in Berlin researched Brande's discovery as Faraday joined RI simultaneously with Brande in 1813 and eventually became his successor in the chair of chemistry. Reitlinger and Kraus used a capacitor instead of Brande's balls and proved unequal discharging at both electrodes. The flames of alcohol and oils were attracted to the negative electrode, and the flame of sulphur, phenol and SO₂ inclined to the positive electrode. The results of their experiments were consistent with the predictions of Clausius's theory of electrolysis.³¹⁹⁰

Physics and chemists of those days increasingly focused their research to the diluted gases. They better understood unusually high-temperature plasma in the Sun only after successful experiments with low-pressure cathode ray tubes' discharges. The term "discharge" is still used today, although with it, besides the abrupt spark, we also describe permanent electric currents through gas.

At the beginning of his scientific work in the lecture "On Radiation Matter" twenty-four years old Faraday first narrated about a special substance to the City Philosophical Society in 1816: "...If we now conceive a change as far beyond vaporisation as that is above fluidity, and then also consider the proportional increased extent of alteration as the changes rise, we shall perhaps, if we can form any conception at all, not fall far short of radiant matter; and as in the last conversion many qualities were lost, so here also many more would disappear..."

Faraday developed those ideas soon, but they had to wait for their more challenging proponent like Crookes. Six decades later Crookes referred to Faraday when he described radiation as the fourth aggregate state of the substance: "So distinct are these phenomena from anything which occurs in air or gas at ordinary tension, that we are led to assume that we are here brought face to face with matter in a fourth state or condition, a condition as far removed from the state of gas as a gas is from a liquid (in which its properties are so far removed from those of a gas as this is from a liquid)."³¹⁹¹

The reference to Faraday has further enhanced the popularity of Crookes' ideas in Britain. Unfortunately, Crookes died prematurely to recognize the realization of his assumptions about the fourth aggregate state in modern plasma physics. Certainly, Crookes' daring proposals and his widely known spiritism got a great opposition among the Germans.

³¹⁸⁸ Reitlinger, 1861, 534, 25.

³¹⁸⁹ Brande, 1814, 1; Reitlinger, Kraus, 1862, 389.

³¹⁹⁰ Reitlinger, Kraus, 1862, 368, 388–389; Šubic, 1862, 199–200.

³¹⁹¹ Crookes, Theory of the Radiometer, *Chemical News*, 1876, 34: 277; Crookes, Experiments on the Dark Space in Vacuum Tubes, *Proc. Roy. Soc. London*, 1907, 79/528: 98–117.

29.2 Modern Plasma

29.2.1 What Shines in the Sun?

At the time of the first Crookes papers on the fourth aggregate state, on the 20th of March 1879, Stefan calculated the acceptable temperature of the Sun as 5586°C (Figure 29-1).³¹⁹² During the following four decades, people searched for fuel which gives the sun so much energy without exhausting its supply.

In 1854, Helmholtz used gravity as the source of the Solar energy. He calculated the course of the solar shrinkage due to the loss of energy, but he computed too low age of the Earth. Similarly, W. Thomson thermodynamically determined his much lower age of the Earth compared to the age needed by geologists for their studies of the fossil remains.

Later, on May 20, 1904, Kelvin reluctantly listened to the professor of McGill University in Montreal Rutherford's Bakerian lecture on newly discovered radioactivity as the source of the internal energy of celestial bodies. Rutherford had in mind fission, not fusion, when he said that: "... the existence of a radium in the Sun in the ratio of four parts per million per million covers by itself the present irradiated heat. The discovery of radioactive elements, which, at the time of its disintegration, liberate enormous amounts of energy, thus increases the possible life limit on this planet and allows the time that geologists and biologists require for evolution."³¹⁹³ Of course, Rutherford hoped to tell this openly just because Kelvin first nodded and afterwards got a little nap. Unfortunately, his conclusion suddenly waked up Kelvin. The frightened Rutherford immediately added the observation that Kelvin's theory of the cooling of the Earth is perfectly correct, and the discovery of radioactivity just supplements it in some cases.

Rutherford's similar conjectures about the processes with which the Sun is shining were read four years later in the Slovene language. The text mentioned the helium, while it contained much more reminiscences of the modern description of the fusion of nuclei in stars: "We can ask ourselves, why the heat from the sun, apparently

never runs out ... There is a huge amount of helium gas in the sun. It is very probable that this helium was formed from radioactive substances, which are also found in great quantities at the sun. If this opinion is right, it is not difficult for us to explain why the solar output is unchangeable. When helium is formed from radioactive substances, so much heat is developed to maintain solar heat at its same level..."³¹⁹⁴

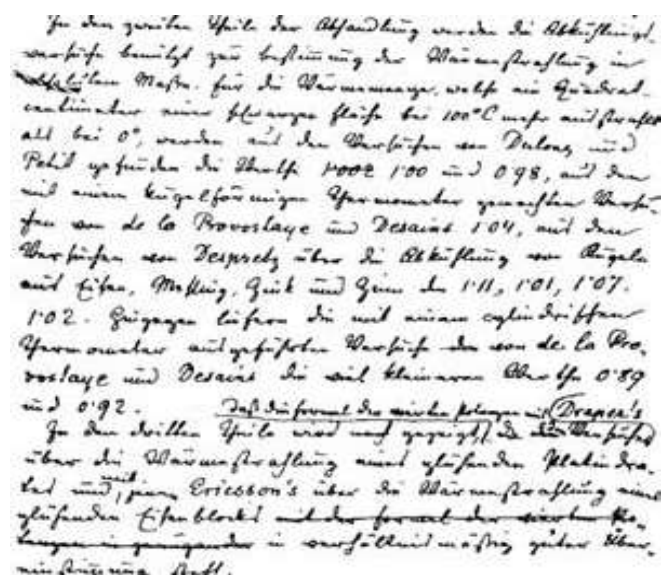

Figure 29-1: Facsimile of Stefan's manuscript of his calculations of temperature of the Sun at a session of the Viennese Academy on 20 March 1879.³¹⁹⁵

In 1920 and 1925 in Cavendish's mass spectrometry laboratory, Aston found that the helium has 0.8 % less mass than four protons. The chemist Harkens of the University of Chicago called the difference "binding energy". The director of the Cambridge University Observatory, the Quaker Eddington, attributed the energy of stars to the fusion of hydrogen atoms into the heavier elements.

In 1928 in Gottingen, the German Houtermans and the Russian theorist Gamow wrote the discussion of the collapse of α particles involving a tunnel effect. Houtermans thought that an inverted process is possible, in which the nucleus absorbs the α particle and then decays. However, such a fusion was not feasible by the energy available in the laboratories of the time. While studying in Gottingen the young British physicist, Robert d'Escourt Atkinson (1898 Rhayader in Wales-1982

³¹⁹² Stefan, 1879, 36–37.

³¹⁹³ Wilson, 1987, 220.

³¹⁹⁴ Čadež, 1908, 46.

³¹⁹⁵ AVA MinCU 282 ex 1879, 4.

Indiana) focused on Eddington's determination of the temperature inside the stars³¹⁹⁶ where energy was not lacking.

In March 1929, Houtermans and Atkinson wrote their paper titled "How to Cook Helium Nucleuses in a Potential Pot", but the disgruntled mainstream editors changed the title to "The Question about the Possibility of Synthesizing Elements in the Stars."

After his article on nuclear reactions as a source of energy of stars, Houtermans walked under the starry sky with a pleasant bride, his later wife. "Do they not shine beautifully?" she gently whispered to him. He shrugged and said, "From yesterday, I know why they shine." Charlotte subsequently married and divorced her star Houtermans twice instead of her other candidate even wealthier millionaire Oppenheimer with Pauli always as their best man, but Pauli was famous for ruining all experiments at a distance...

Friedrich Georg Houtermans ("Fizzl", 1903; † 1966) from Zappot by Danzig (today's Sopot by Gdansk) grew up in Vienna, where his mother Elza, a half-Jewish woman, received the first doctorate in chemistry awarded to a female. In 1921 Friedrich Georg Houtermans began studying physics in Gottingen. However, due to lack of money, his studies had to be interrupted and he supported himself as a tourist guide in Rome. In 1927 in Gottingen he completed the dissertation on resonant fluorescence in mercury with James Frank, who shared his Nobel Prize with G. L. Hertz in the previous year and later joined the Manhattan project. In 1929, Houtermans assisted Wilhelm Westphal and later Hertz at the Technical College in Berlin. For Hertz, Houtermans developed an electron microscope, which was at that time under construction by several research groups in Germany. In August 1930, during a Physics Conference in Odessa, Pauli was a best man at the first and later again to third marriage of Houtermans and Charlotte Rieffenstahl (1899 Bielefeld, Germany-1993 Northfield, Minnesota), who received their doctorates in physics at Gottingen together with Oppenheimer. In 1932, Houtermans was habilitated at the university, but due to his Jewish origins and as a member of the German

Communist Party, he left Germany to work in a laboratory of electrical and musical equipment store near London in the summer of 1933. In December 1934 he went to the Physics and Engineering Institute in Kharkov, where he researched with Landau. Houtermans worked in an experimental laboratory for nuclear physics but he was arrested on 1 December 1937 as a German intelligence spy, much like the Jew Landau half a year later. Landau's exam with their theoretical minimums were legendary Peterlin's models; Landau suffered from political intrigues like Peterlin and even harder because Landau was not willing to leave Soviet Union, while Peterlin never got his strong backer Kapitsa like Landau did. Like Peterlin or Plemelj, Landau was unable to produce his own textbook without Evgeny Mikhailovich Lifshitz (Lifšic), but Landau's car accident was the disgrace like Kuhelj's, the accident that almost no one of their scientific capacity ever suffered. On 25 April 1940, the foolish Russians handed Houtermans over to the Gestapo. Von Laue saved Houtermans from their claws. In 1941 Houtermans was able to join the private laboratory of von Ardenne in Lichterfelde near Berlin, where he studied the theory of the chain reaction for the state post office. Before the end of the war, he moved to the 2nd Physics Institute in Gottingen, and in 1952 he became a professor at the University of Bern. He died in Switzerland in 1966.



Friedrich Georg Houtermans (* 1903; † 1966)³¹⁹⁷

³¹⁹⁶ Eddington, 1928, 18, 149, 364, 368, 392, 394.

³¹⁹⁷ Khriplovich, 1992, 30.

But Houtermans and Atkinson had almost no experimental results available. They knew that at higher temperatures at the core of the Sun, hydrogen atoms could come nearer to their electrons. The high pressure in the Sun would then compress the atoms into a mixture of protons, eight times thicker than lead. They calculated that fusion of hydrogen would generate enough heat of the Sun. But they did not know whether a mixture of protons in the conditions of the Sun would in fact sustain a thermonuclear reaction.

Later the folks found that Houtermans and Atkinson incorrectly determined the cross-section for capture in the nucleus and the likelihood of radioactive decay. However, the errors mutually annihilated each other to enable the sound results. Houtermans description of the nuclear reaction gave Cockroft the idea to build a proton accelerator. In 1932, Cockroft completed it along with six years younger Ernest Walton at the Cavendish Laboratory and later joined the Manhattan project.



Figure 29-2: Hans Bethe (lower row, first from right) with Richard Feynman (* 1918; † 1988) at a meeting in Rochester in January 1952

In 1938, at the University of Cornell, Bethe already had experimental researches of nuclear reactions available, since in the early 1930s fusion reactions were in the focus of research on high-energy physics. He calculated how fast the protons must chain reaction fuse with each other to keep the hot stuff inside the Sun.

In the years 1938 and 1939, Bethe and Teller's PhD student Charles Critchfield (1910 Ohio-1994 Los Alamos) found that the thermonuclear reaction in the universe was carried out in two ways: in hydrogen (proton-proton) or in the carbon cycle. The later was independently discovered in Berlin by the German Heisenberg's collaborator Karl baron Weizsäcker (1912-2007).³¹⁹⁸ The hydrogen cycle strongly resembled the quantitative proposals of a wide variety of researchers, including M. Curie in 1912 and independently Perrin, Eddington and the Swedish initiator of global warming ideas Arrhenius in 1923.³¹⁹⁹

The German **Hans Albrecht Bethe** was born in Strasbourg, where his father co-operated with Braun at university (Figure 29-2). He studied physics at Sommerfeld's class in Munich in 1928. He continued his research work with Rutherford in Cambridge, and with Fermi in Rome. At the beginning of the pressures of Nazi authorities in 1933, Bethe's professional route at the universities in Munich and Tübingen was interrupted because of his Jewish mother and he left for England. In 1935 he went to the University of Cornell in the United States, where he became a professor of physics two years later. In 1940, Debye came to Cornell as a professor of chemistry. Bethe was the head of the technical department for production of the atomic bomb in Los Alamos. In the last year of the war, under Bethe's leadership, his year and a half younger friend the naturalized American Edward Teller studied a hydrogen bomb.

In 1949, Bethe patented an invention associated with a hydrogen bomb.³²⁰⁰ After the war in Geneva, he participated in negotiations with the Soviet Union for controllable nuclear testing. Bethe's pioneering work evoked enthusiasm and vigorous debate, as it turned out that the giant stars could not radiate with today's brightness for billions of years. Since they were not yet aware of the passage of the star to a state of lower intensity, in 1948 Spitzer assumed that star giants had to arise relatively late from the dust in the spiral constellations (galaxies).³²⁰¹

³¹⁹⁸ Lapp, 1960, 162.

³¹⁹⁹ Perrin, 1927, 277–278; Eddington, 1928, 368.

³²⁰⁰ Lapp, 1960, 162.

³²⁰¹ Spitzer, 1997, 3, 51.

Subrahmanyan Chandrasekhar of Lahore graduated from the University of Madras at the age of twenty. During the long summer journey of 1930, he calculated his theory of white dwarfs while traveling to England, where he studied under supervision of the professor Dirac in Cambridge and received his Ph.D. in 1933. He disputed with Eddington over the reality of black holes and the upper limit for the mass of white dwarfs. Although Eddington's sharp criticism at the meeting of the Royal Astronomical Society in January 1935 almost destroyed Chandrasekhar's career, he remained an admirer of Eddington's work. Eddington for himself did not feel guilty as he supposed that if the famous Eddington mentioned virtually unknown Chandrasekhar was good for Chandrasekhar even if Eddington criticized Chandrasekhar. Subrahmanyan Chandrasekhar's second cousin Sivaramakrishna Chandrasekhar (1930-2004) discovered discotic liquid crystals in 1977.

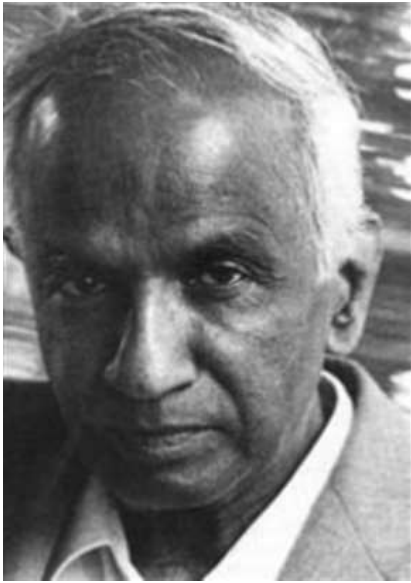

Subrahmanyan Chandrasekhar (* 1910; † 1995)

Since Ralph Howard Fowler (1889-1944), Rutherford's only son-in-law and Dirac's professor at Cambridge, explained high-pressures inside the stars with a model of gas of nucleuses and electrons. His research was continued by Chandrasekhar, a Dirac student at Cambridge. In 1931, Chandrasekhar announced that white dwarfs, discovered by Adams in 1915 and studied by Eddington, consisted of a highly compressed substance, the plasma. After the war, Chandrasekhar, as a professor in Chicago,

continued to solve astrophysical problems together with Fermi.³²⁰²

1937, Chandrasekhar worked at the University of Chicago. In 1944 he became a professor, and in 1953 he became a naturalized American. In 1983, he shared the Nobel Prize in Physics with William Alfred Fowler (Pittsburgh-1995 Pasadena), a professor at Caltech. Since 1947, Fowler has simulated thermonuclear reactions in the laboratory, as they should take place in the stars. In doing so, he was helped by the rich experience of investigating elementary particles in accelerators. When in 1953 five years younger English astronomer Fred Hoyle visited Fowler's Caltech Institute, they began a long research of the synthesis of chemical atoms in stars and additionally in supernovae in 1980. Subrahmanyan Chandrasekhar explored liquid crystals at Raman Research Institute in Bangalore. He died in Chicago. Subrahmanyan Chandrasekhar's article is noted among the nicest one ever written in science and Podgornik also loved it as one of the best he ever read.

29.2.2 *Langmuir's Study of Fluctuations in a Plasma*

The research of plasma gradually moved from academic institutions into the industrial labs. In the middle of 1920s, Langmuir focused the hydrogen gas stream to a heated tungsten filament tube to dissolve hydrogen molecules atoms. When the hydrogen stream was distracted to the hot parts of the experimental device, the atoms reunited in the molecules while the heat of recombination raised the temperature to near 6000°C, just like the surface of the Sun.

The most important properties of the plasma were measured with the voltage between the walls of the vessel and Langmuir's thin probe made of from a high melting metal such as tungsten or molybdenum. An adequate tiny probe could not perceptibly change the distribution of plasma tension. In arc discharges in mercury vapors with his heated cathode at room temperature he detected many possibilities for accelerating primary electrons up to speed above the potential difference in the cathode ray tubes. Other electrons had lower

³²⁰² Spitzer, 1956, 12–14.

speeds, so on average, energy was just the right one.

Numerous explanations of the phenomenon did not fully fit. A natural assumption was made that electrical arcs caused scattering, with the influence of rapidly changing electric fields on electrons, as well as with voltage changes on electrodes. In 1923 and 1924, Langmuir's collaborator at the research laboratory of the General Electric Company at Schenectady A. F. Dittmer discovered a particularly pronounced anomaly in a thin layer a few millimeters away from the fiber using Langmuir's technique. To explain Langmuir's discovery of unusually strong scattering in the arc, Dittmer first announced strong internal fluctuations. The oscillatory period were comparable to 10^{-8} s with the continuous transition of primary 50 kV electron energies from the thread to the areas of maximum scatterings, but he was unable to detect them.

Even before the printout of Dittmer's discussion Kamerlingh Onnes' PhD student Frans Michel Penning (1894-1953 Utrecht) in Eindhoven Philips' labs published observations of controlled oscillations of frequencies of radio waves in low-pressure arc discharges in mercury vapours under the same conditions as those that led to the electron scattering, which convincingly confirmed the correlation between the observed strong scattering and radiation.³²⁰³

In addition to surprisingly strong scattering, they observed two other specificities of glow discharges in gases, associated with plasma fluctuations. The first of these was the "angular" scattering of the primary jet near the cathode at the arc. It was most convincingly examined by Karl George Emeleus (1901-1989) and his students from the Queen's University of Belfast with simplified Langmuir probes after 1941. Emeleus was a former Appleton's PhD student and Dirac's fellow member of Kapitsa's Cambridge club. Emeleus and his assistants described several times the connection between the angular scatterings of the primary jet and the existence of primary oscillations in discharges. They used tungsten cathode in mercury at low pressure and anode in the form of a coaxial cylinder. A sufficiently small movable probe that was not detectably changing

the distribution of plasma tension was placed between the electrodes. At a voltage of 15 V to 100 V and an electrical current from a few milliamps to 100 mA, fluctuations with wavelengths of about 10 cm were almost always detected at very different frequencies and amplitudes (Figure 29-3).

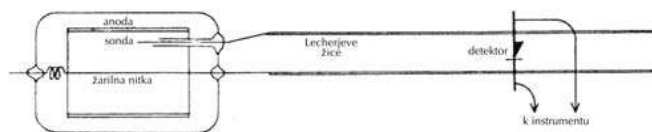

Figure 29-3: A simple probe for detecting plasma fluctuations³²⁰⁴

Another special kind of feature is sometimes nicknamed Langmuir's paradox which Langmuir described in 1925 and D. Gabor named a decade later. They detected the anomalous short relaxation length of the cathode beam and the existence of a Maxwellian electron energy distribution in the positive column of a DC arc discharge at low gas pressure. The electrons of an electrical discharge in a gas contradict theoretical indications with their same velocity distribution as the molecules of a gas. Maxwell's distribution of electron energies is maintained at discharge in gas very close to the insulated wall. The measurement surprised the researchers, since on the negative charge of the wall only high-energy electrons from the gas are collected, and therefore they detract Maxwell's distribution of electrons nearby. Far from the wall, Maxwell's distribution is restored due to the energy transfer of collisions between electrons and other charged or neutral particles. In any case, the average free paths of energy transfer were known to be larger for several orders of magnitude than the very small distances needed to restore the equilibrium distribution of discharges.

29.2.3 Naming of Plasma

A century ago, Crookes' idea of the fourth aggregate state passed to Langmuir, who named it "Plasma" and described the fluctuations in it. Langmuir studied the neon lamp and measured the parameters of the low temperature plasma in the diluted gas with the probe.

In the spring of 1928 during his exploration of arc discharges in mercury at low pressure at room temperature, Langmuir asked his colleague at GE

³²⁰³ Tonks, Langmuir, 1929, 195; Lafferty, 1998, 319-320.

³²⁰⁴ Gabor, 1951, 209.

for advice: "Look, Tonks, I'm looking for a name. For these glow discharges, the area is in the immediate vicinity of the electrode wall as the "border layer", which is fine. But how do we call the main part of the discharge? Conductivity is large there, so you cannot get a voltage difference as with a boundary layer that collects the entire charge. We have a complete neutralization of spatial charges there. I do not want to make up the name, but I need to describe this type of space separately from the boundary layer. What do you suggest?" Langmuir, of course, exaggerated the tension and neutralization of spatial charges, but Tonks took the time to think. Unfortunately, he was too slow, because Langmuir came to him the next day and proclaimed, "I know how we will name it! We will call it 'plasma.'"

The paper with the new term was sent to print on June 21, 1928 (Figure 29-4). Crookes dreams come true after his German critics have all died and even Crookes himself passed away nine years ago.

$$\delta n = n \delta \zeta / \delta x \quad (1)$$

Originally the net charge was zero, so after the displacement Poisson's equation gives

⁴ Langmuir, Proc. Nat. Acad. Sci. 14, 627 (1926).

⁴ The word "plasma" will be used to designate that portion of an arc-type discharge in which the densities of ions and electrons are high, but substantially equal. It embraces the whole space not occupied by "sheaths." See Footnote 4.

Figure 29-4: The first mention of the term "plasma" and electronic fluctuations in Langmuir and Tonks's discussions on 20 November 1928³²⁰⁵

Thirty-nine years later Tonks remembered that Langmuir mentioned blood in his choice. He chose the name in contrast to the name of the "border layer" along the wall to describe a wide spectrum of phenomena of motion in electrolytes, flames and the Heaviside layer in the atmosphere. The choice of the name was not influenced by the characteristics of unstable oscillating plasma, nor by twisting motion in living cells, nor by the similarity with the protoplasm. At that time, they knew much about gases and much less about blood plasma than today. Tonks and Langmuir used the name of the plasma for that part of the arc-type discharge, where the density of the ions and electrons is high, but essentially the same without

much differences among them. Plasma comprises all the space not occupied by the "boundary layers (sheaths)".³²⁰⁶ Partially ionized gas is called plasma when Debye's length is small in comparison to other distances.³²⁰⁷

Langmuir was extremely successful in inventing new names. Among other things, in 1914, he helped to establish the "-tron" suffix, which is still held by a wide range of electronic devices. He had very useful ideas, and above all important links to put them into circulation. The other guy who loved to invent newly coined terms in physics was Clausius, although Clausius relied on the ancient Greek language and his suggestions were not always accepted as Maxwell, Tait and other Brits made fun of several of them.

In 1911, Langmuir acquired one-atom hydrogen and described the metal welding in hydrogen flame. In 1913 he published the law of thermionic emission which is still named after him. In 1916 he constructed a pressure gauge and a high-vacuum pump. Three years later he presented his model of atoms based on the older Bohr's ideas. He has also become known by the Langmuir and M. Sah's equations that connect the surface ionization to the surface temperature of the metal, its output, and the ionization potential of atoms. Together with his rival Berkeley suicidal professor Gilbert Newton Lewis, Langmuir set up a theory of chemical valences. In 1916 Langmuir published the equation of isomerism of single-molecular adsorption. Langmuir also helped inventor Westinghouse's AC contractor William Stanley (1858 Brooklin-1916) to solve his problems of heat transfer in the metallic thermos, which helped his invention of a 25% more efficient vacuum bulb.

In 1932, Langmuir was awarded the Nobel Prize in Chemistry as the first American industrial scientist for his investigation of monomolecular surface thin films. In the same year in 1932, Coolidge succeeded Whitney as director of GE's laboratory, and Langmuir became director and later the adviser. Among GE's advisers were the other Nobel Prize winners: Hans Bethe of Cornell, Ernest Lawrence of Berkeley and Eugene Wigner of Princeton who later joined the Manhattan project.

³²⁰⁶ Tonks, Langmuir, 1929, 196.

³²⁰⁷ Spitzer, 1956, 17.

³²⁰⁵ Tonks, Langmuir, 1929, 199.

In 1903, **Irving Langmuir** from New York became a metallurgical engineer at the University of Columbia. Three years later, he received his Ph.D. in Göttingen under supervision of the professor of Electrochemistry Nernst, a former Boltzmann's student. Nernst was not a useful consultant, and Langmuir got much more help from the former Plücker pupil, the mathematician Klein, who also taught at the University of Göttingen between 1886 and 1910. After several years of chemistry teaching, Langmuir listened to a classmate's advice and began research work at the GE Research Laboratory in Schenectady, New York, where Edison moved his research facilities in 1886. At the beginning of December 1900, the Laboratory was set up in a barn near Steinmetz's house. Steinmetz set up the former chemistry instructor at MIT, Whitney, for the first director of research at GE with one assistant. Whitney studied in Leipzig and then taught at MIT.³²⁰⁸ Langmuir wrote to his mother: "While I am in Schenectady, I will look for a really goody job at the university." This "while" was extended to nearly half a century of Langmuir's GE research. Times changed as research was not necessary coupled with teachings anymore because modern science produces money of its own.



Irving Langmuir (* 1881; † 1957)³²⁰⁹

By the end of the Second World War GE labs more closely resembled Edison's time than Einstein's era. GE's researchers were dealing exclusively with electricity, where they had strong patents. They worked in small groups according to the method that was baptized in Cambridge as the "classic tradition of cords and seal wax". Langmuir, with his colleague the learned chemist-meteorologist Vincent Schaefer (1906 Schenectady-1993 Schenectady) and the first female physicist in industrial laboratory the same-sex Boston marriage households practitioner Catharine Burr Blodgett (1898 Schenectady, New York -1979 Schenectady, New York), discovered single-molecular thin films of liquid on the liquid during the search for a better lubricant for bearings. They are called Langmuir-Blodgett's layers.

In 1939, Langmuir was impressed by Hahn's discovery of a nuclear chain reaction, so that Kenneth Hay Kingdon (1894 Montego Bay in Jamaica-1982 Schenectady) and the chief plant steward Howard C. Pollock began exploring GE's uranium in 1940, which at the end of the war turned into the core research group. In 1947, Langmuir, Pollock and Franck R. Elder first detected synchronic radiation on the 70 MeV synchrotron.

In 1945, the GE had 630 staff including 160 scientists and engineers. About half of them previously studied physics, 30% chemistry, 15% metallurgy and 5% mechanics. Soon after Whitney, Coolidge retired in 1946. At the end of 1948 they were followed by Dushman and Albert W. Hull. In 1950, Langmuir joined them. At that time, there were already 1000 people working in the laboratory who were able to set up a new building in Electric's Knolls Atomic Power Laboratory, near Schenectady, New York. New generations of researchers and market competition then already demanded the implementation of major projects at GE.

Irving Langmuir considered that he had avoided the possibility of fluctuations in plasma during his experiments.³²¹⁰ Following Dittmer's 1926 paper, Langmuir together with Tonks, investigated the fluctuations of very high frequencies, in 1928 and in February 1929. They published a simple theory of plasma-electron oscillations in an ionized gas with a single mechanism for clarifying both the

³²⁰⁸ Bowers, 1998, 145.

³²⁰⁹ Redhead, 1994, 79.

³²¹⁰ Gabor, 1951, 210.

special nice features of electric discharge in gases: "angular" scattering and Langmuir paradox. The famous J. J. Thomson by his personal letters helped them to find some of the theoretical solutions. The new theory was based on completely uniform, macroscopically neutral plasma at zero temperature. After every small displacement of the electrons from an approximately neutral equilibrium Coulomb force restores the balance. There are harmonic oscillations with a characteristic frequency called by Langmuir's name, although they were first described in Lorentz's electron theory in 1909. However, Lorentz considered transverse waves, while Tonks and Langmuir described the longitudinal waves of a completely different nature. To emphasize the difference, Langmuir's waves were called electron-acoustic waves (sound type oscillations in Langmuir-Tonks notation of 1929), although the name is not quite appropriate. Initially Helmholtz, Roentgen, Hertz, and the eternal Tesla were trying to prove their own kind of longitudinal waves, but they never had much luck.

In addition to these waves, others are also possible in plasma. Among them acoustic and later hydromagnetic (Alfvén's) waves were detected in 1942.

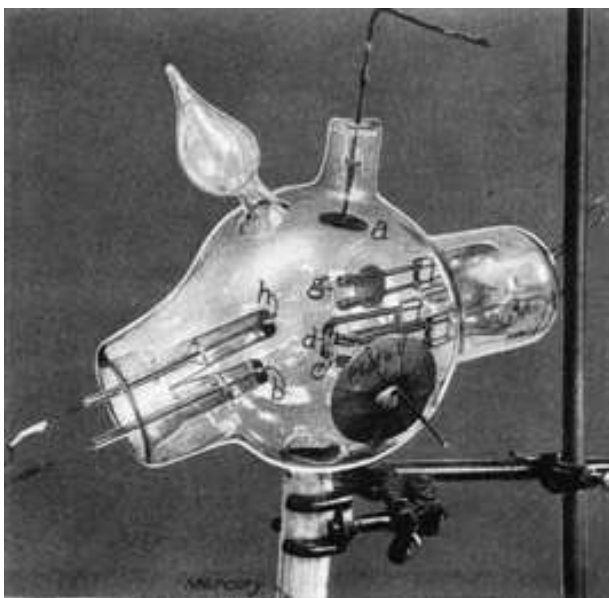

Figure 29-5: Langmuir and Tonk's measuring apparatus, described on 20. 11. 1928³²¹¹

In 1929, Tonks and Langmuir noted two theoretically possible oscillations: the oscillations

³²¹¹ Tonks, Langmuir, 1929, 202.

of electrons of 1000 MHz are too fast to be followed by the heavy ions. The oscillations of ions are so slow that they always leave the density of electrons at the equilibrium value corresponding to Boltzmann's law.

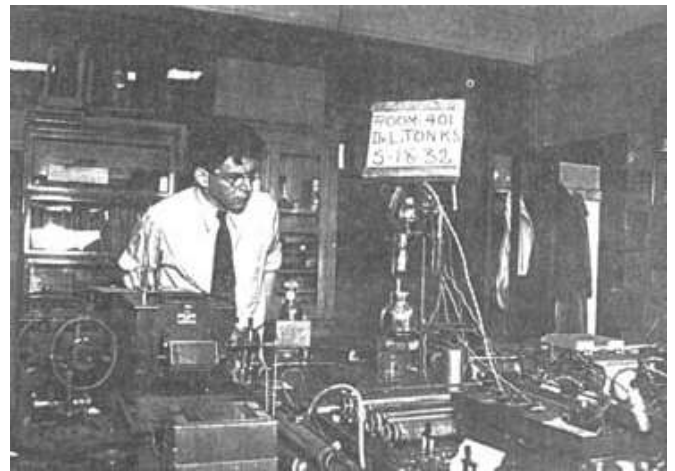

Figure 29-6: Lewi Tonks (* 1897; † 1971) in the laboratory³²¹²

Lewi Tonks received his doctorate in 1923 at the Pupin's University of Columbia, where he studied a generation after Langmuir (Figure 29-6). Three years after graduation Tonks started working at GE. In 1937, he named the "pinch"-effect, which Bennett discovered three years earlier as "magnetic self-focussing streams". The term pinch was jokingly used by Carl Hering (1860 Philadelphia-1926 Philadelphia) and his friend former Rowland's assistant Edwin Fitch Northrup (1866 Syracuse-1940) in 1907.

In 1929, Tonks and Langmuir measured in two cathode ray tubes containing filamentary cathodes used as the sources of electrons. The collectors were placed in such a way that they received a part of the direct stream of primary electrons from the filament. Off to one side they put an anode that maintained the discharge. In the first tube, two tungsten filaments were supported near the middle of the 18 cm spherical bulb by long leads (conductors) covered with glass. Their exposed portions were about 1.1 cm long and parallel at distance of 0.5 cm from each other. 4.2 cm away they put a round collector, a circular disc plate with a diameter of 1.1 cm backed by mica. Their second

³²¹² Stroke, 1994, 724.

cathode ray tube was the same, although it had three vertical tungsten filaments and not just two (Figure 29-5). With ZnO-Te-detector and galvanometer, they detected oscillation frequencies (fluctuations) with the frequencies of plasma-electron oscillations.³²¹³

In the next volume of *Phys. Rev.* Tonks and Langmuir also studied the boundary layer formed at contact of the plasma with a solid surface without any magnetic field.

They used different assumptions about the potential difference between the plasma and the wall; the thickness of the boundary layer was roughly given by Debye's length (Debye and Eric Hückel's (1896 Berlin-1980 Marburg) distance calculated at ETH in Langmuir's narration), which is like the reciprocal value of the ionized fluid's absorption coefficient for electric forces.³²¹⁴

29.2.4 "Pinch"-Effect

The great global economic crisis brought together in plasma physics the research of astronomers (later called astrophysicists), geophysics and fans of discharges in diluted gases. For Langmuir's definition of plasma, there was still an essential electric field, which caused heating and ionization. Later, plasma became a synonym for partially ionized gas.³²¹⁵

Langmuir's heirs studied the unusual behavior of plasma in a magnetic field, and in the next decades they developed a new branch of science called magnetohydrodynamics. Physics of plasma has already quickly given its sense in the efforts to explore space and to simulate cosmic conditions in local laboratories. The basic problem was not the ignition of plasma, but its retention in a limited space. As with the electron microscope in the early 1930s or later with the unworkable fusion power plants, plasma researchers decided to prefer to keep the plasma with the electromagnetic fields far enough away from the walls of the container, as they did not believe that any material could withstand such higher temperatures. That was the same problem which still bothers the inventors of fusion reactors whose success is always a decade

ahead. Rutherford's student Mark Oliphant (1901 Adelaide-2000 Canberra) designed his Cavendish lab nuclear fusion of hydrogen isotopes in 1932, a half of dozen years before the escaped Jewess Lise Meitner and her Berliner ex-colleagues described nuclear fission. Still, the fission bombing of Japanese happened a half of dozen years before Pacific nuclear fusions while the controlled fusion reactor is among the longest delayed technological applications of theory along with Tesla's tower and coil despite Matjaž Panjan's optimism.

On February 15, 1932, at Thomas Corwin Mendenhall's (1841-1924) Laboratory of Physics at Ohio State University physicist Bennett assumed that the breakdown in cold-emission (field discharge) was caused by small streams of quick positive ions from the anode, which strike the cathode along the electron current. Bennett's important term breakdown designated the modification in the not entirely outgassed cathode which causes the current to change suddenly in its order of magnitude without any change in the "measured field".

If the current of ions is less than 10^{-2} A, they eliminate all emitting points by their collisions. The stronger currents, on the contrary, cause damage on the surface of the cathode and thus create new emission surfaces. The positive ions formed from residual gas or at the anode by the electron stream would at least partly follow the stream back to the emitting point. This bombardment of the emitting point by positive ions, if their current is not too concentrated, would eliminate the emitting point, perhaps by pounding it down. The breakdown in cold emission, at pressures of 10 mm or less, is due to a stream of positive ions with high velocity, which is produced by an initially small electron current striking the target of the emission (cathode). Elimination of cold emission from high voltage tubes, by using electrodes which were not outgassed, depends on preventing the positive ions leaving the target from hitting the cathode with high velocities. Bennett could not explain that phenomenon, therefore, in next months he used his new million-volt tube applied to centimetre surfaces at short distances from the anode to produce measurable emission. In the case of high voltage tubes, the longer distances and the higher voltages, he formed self-focussing streams.

³²¹³ Tonks, Langmuir, 1929, 203–210.

³²¹⁴ Tonks, Langmuir, 1929, 201, 876–922; Spitzer, 1956,

17–18.

³²¹⁵ Alfvén, 1963, 134–135.

On January 13, 1933 published only in June 1934, he described a "pinch" effect discovered at his State University of Ohio when he investigated the causes of cold-emission breakdown and regulation of plasma with magnetic fields:

"Streams of fast electrons which can accumulate positive ions in sufficient quantity to have a linear density of positives about equal to the linear density of electrons, along the stream, become magnetically self-focussing when the current exceeds a value which can be calculated from the initial stream conditions..." Self-focusing particles approach the axis in an ever-increasing part of the electron stream... This type of process can be continued into infinity if magnetic self-focusing is obtained in each part of the stream, which is long compared to its own diameter ...

The described process is probably only short-lived of the order of 10^{-4} s or 10^{-5} s. Later streams cease to be self-focusing since the transverse energy of the electrons along the sharp edges of the craters of the cathode becomes too large or too close to the cathode, or the density of matter increases so that we can no longer ignore the collisions (Figure 29-7).

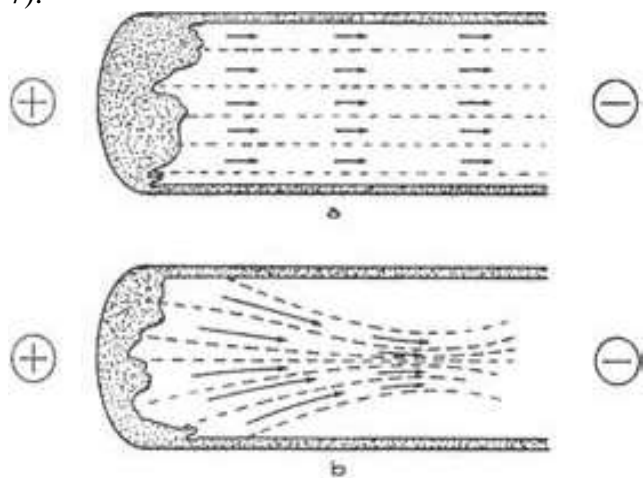

Figure 29-7: The scheme of "pinch-effect"³²¹⁶

The researchers before Bennett studied the focussing effect of residual gas on slow low voltage electrons because the ions have much smaller velocities than the electrons freed by ionization of the residual gas. Nobody studied focusing effect on electron streams due to the magnetic attraction between the parts of electron stream, which becomes important at high voltages.

³²¹⁶ Gamow, 1961, 132.

Willard Harrison Bennett of Findlay graduated from the University of Wisconsin in 1926. Between 1928 and 1930 he worked at Caltech, and then at the University of Ohio until 1938. Between 1946 and 1950 he researched at the National Bureau of Standards. Academic jobs followed: from 1951 to 1961, he lectured at the University of Arkansas, and then at the University of North Carolina where he met Peterlin although their fields of research were not the same. He developed the principle of a tandem Van de Graaf accelerator.

Bennett has proven that breakdowns by cold emission are not caused by structural defects in the surface of the cathode, but rather by the circumstances in the flow of plasma. He concluded his description of breakdown in cold emission in June 1934:

- 1) The breakdown was much more abrupt when the electrodes are not outgassed than when they are outgassed.
- 2) The fineness of the polish on the surface of the cathode does not affect the value of the field intensity at which breakdown occurs" but only affects the fields at which the first small currents pass (surface impurities are not the cause of breakdown).
- 3) Without outgassed electrodes, after breakdown has occurred, if a field intensity a little less than the field at which breakdown occurred is applied to the cathode, large sudden surges of current pass through the tube, similar in every observable respect to the surge of current which accompanied the original breakdown, but the frequency of occurrence of these surges decreases with time.
- 4) We can prevent the breakdown or at least greatly diminished by outgassing (both) electrodes or by increasing the resistance in series with the source of potential to a value which will limit the maximum value to which the current can rise, to the order of 10^{-3} or less.
- 5) Before the breakdown, the current is very erratic, rising abruptly, and dropping sometimes abruptly, and sometimes gradually; these erratic fluctuations while the current is small occur at

values of field much higher than the values of the field for the same order of magnitude of current after breakdown; but once the value of the current has increased to more than the order of 10^{-2} amperes, the resistance of the tube decreases and the surface of the cathode becomes permanently altered to give much higher order currents at a given field than before.

6) During the breakdown, Bennett noticed small flashes of light both at the anode and at the cathode

He could not explain his discoveries with the older ideas of tearing up impurities or pieces of metal bodily from the cathode with the field. It more resembled the idea of magnetically self-focusing streams.

Bennett's charged particles form an electric current which can induce their own magnetic field. This then pinches the plasma together and forces individual ions to collide with each other. The more powerful and more frequent the collisions, the "hotter" the plasma is, the greater is the likelihood of fusion of nuclei.

29.2.5 *The Kinetics of Plasma*

The Americans were good, but the Soviets were no worse. In 1936 and 1946, Lev Davidovich Landau (Davidovič) and Anatoly Alexandrovich Vlasov (Анатóлий Алексáндрович Влáсов, 1908 Balashov-1975 Moscow) in 1938 studied the plasma kinetics. Landau lifted away Langmuir and Tonks' limits set on a zero temperature. It has been shown that Langmuir frequency³²¹⁷ is not the only frequency of vibration of pressure, but only the lower limit of vibration frequencies associated with the smallest damping of the diffusion type. The spectrum of vibrations is regulated by a dispersion law that connects the frequency with the wave number of the disorder. For the upper limit of the frequency spectrum, Landau equated the wavelength of the oscillations with Debye's length, defined as early as 1912. Landau first explained that there were no collisions in the diluted plasma, but there was a damping of the waves. The plasma electrons move chaotically at different speeds. Some electrons move together with plasma waves, as they have such a velocity that they remain all the time in the front of the waves. Thus, they are

³²¹⁷ Tonks, Langmuir, 1929, 198.

always under the influence of the same electric field, and therefore everyone equally accelerates and stops. For decades, this "dampening of Landau" was practically useless; in hot plasma, there were not enough high-speed electrons that would generate enough current in terms of the power input. The change occurred in 1978 after theoretical plasma research in TOKAMAK at MIT, so today with the damping of Landau we additionally heat plasma in the regulation of thermonuclear reactions. It was the same old story of the invention waiting for its users with the only exception of Tesla's coil and tower which are still on the waiting list a century after their invention.

29.2.6 *Magnetohydrodynamics*

In 1822, Ampère investigated the movement of the conductive liquid, i.e. mercury in a magnetic field. He tested the "electric mill" that turned the magnetic needle on the surface of mercury. However, because of the low conductivity of mercury, hydromagnetic phenomena were weak and they have not been observed during previous centuries.³²¹⁸

In his investigations of transport phenomena in liquids Stefan used equations of the hydrodynamics of a continuous substance on the problems of kinetic theory of gases. In this way, in 1886, he avoided determining the force between molecules, since he did not know with certainty its dependence on distance. Half a century later, the completed mathematics of classical hydrodynamics again helped the physicist in their problems; Alfvén explained a series of phenomena in cosmic plasma with the equations of magnetohydrodynamics in 1942. He published his basic assumptions with the idea of "frozen" magnetic field in plasma and described magnetohydrodynamic waves, a new wave of motion of a conductive medium in a magnetic field. Alfvén's magnetohydrodynamic waves enabled comeback of waves temporarily beaten by Einstein's photons and Heisenberg's matrix quantum theoretical opposing of Schrödinger wave equation. After the success of magnetohydrodynamic waves, many similarities followed including solitons, phasons and the like.³²¹⁹

³²¹⁸ Faraday, 1952, 810–811; Alfvén, 1963, 106–107.

³²¹⁹ T. G. Cowling used the term Magnetohydrodynamics, which Spitzer endorsed at the same time (1956, vi) .

Hannes Olof Gösta Alfvén described the simplest behavior of plasma, as his classic Boltzmann transport theory from the end of the 19th century was retrieved from the closets. Then valid theory of conduction was developed only for partially ionized gas; so, they were only approximately valid for completely ionized gas of charged particles in plasma.

After the end of the Second World War, Spitzer returned to Yale and continued his research of interstellar material from the period before the war. Even after he joined the University Observatory in Princeton, the development of a deeper theory seemed reluctant, with no useful experimental results. In 1948, during Alfvén's visit to the USA, Spitzer became acquainted with the foundations of magnetohydrodynamics, which he developed in the following years. In 1950, he and his colleagues calculated the thermal and electrical conductivity of completely ionized gas. They discussed the influence of the individual electrons on the velocity distribution and described it as a diffusion in the velocity space. Three years later, they published a more detailed theory of astrophysics.³²²⁰

Spitzer early figured out the importance of determining the thermal and electrical "Spitzer" conductivity and mechanical transport coefficients in a fully ionized gas. His pioneering research on plasma physics was crowned by a monograph on the physics of completely ionized gases. As always, the monograph declared that the focused branch of science became a mature recognizable fellow of other branches.

The American Rosenbluth and his co-workers from the Radiation Laboratory of the University of California at Berkeley used Chandrasekhar's idea of 1943 to develop Boltzmann's transport equation for the description of collisions of two bodies with an isotropic distribution function in space and in velocity-space. They numerically solved the simple conservative axisymmetric Fokker-Planck's equation for Newton's force, which is inversely proportional to the square of the distance; Chandrasekhar and Spitzer's approaches were presented as the special kind of cases. As early as on 31 August 1956 they were among the first to propose the use of a computer, which immediately gave their theory a promising gift of modernity.

³²²⁰ Spitzer, 1997, 409; 1997, 434–443.

Hannes Olof Gösta Alfvén from Norrköping, Sweden, studied in Uppsala. Between 1937 and 1940 he worked at the Nobel Institute of Physics in Stockholm, and then he taught at the university there. As a Scandinavian, he was destined to clarify the northern light (Aurora Borealis). He continued the research of Norwegians Carl Störmer (1874-1957) and his assistant Kristian Birkeland (1867-1917) from the late 19th and early 20th centuries. Alfvén connected northern lights with "cathode rays" following the example of Arago's description of Davy's arc-lamp of 1820. In 1939 Alfvén developed the theory of magnetic storm and of the northern lights, which was based on the idea of "frozen" magnetic fields in plasma. In semi-neutral Nazi-influenced Sweden Alfvén was able to make his research heaven without noticing the hell on the Earth during WW2. In 1943, he developed a planetary cosmogony with an early sun piglet, which caused ionization in galactic gas while traveling through a galactic nebula. The ions were supposed to move around the spirals circling the magnetic field of the Sun, and later they become thicker to form the planets. Thus, Alfvén designed a new science called cosmic electrodynamics, which, however, took many years for recognition, so that he had to publish his papers in obscure magazines at first. In 1970, he received a half of the Nobel Prize in Physics.



Hannes Olof Gösta Alfvén (* 1908; † 1995)³²²¹

Their procedure could be carried out sufficiently correctly in the low-pressure plasma limit, where the mean free path is long compared to Debye's

³²²¹ Casimir (anonymous notice), Europhysics news, July-August 2000.

length. In other words, the potential energy between the particles is much lower than the product between the Boltzmann constant and the temperature. Extension to the limit of strong interactions required more complicated statistical mechanics.

Lyman Spitzer from Toledo, Ohio, studied at Yale University in Edinburg, Illinois. After graduating from Yale, he studied in Eddington's class of the college of St. John's in Cambridge between 1935 and 1936. Spitzer admired Eddington, even though he was disappointed with personal contact with him, just like Chandrasekhar used to be.³²²² Between 1936 and 1938 Spitzer completed his doctorate at Russell's class in Princeton, and then taught at Harvard, Yale and Columbia universities. In 1947 he succeeded Russell as a professor of astronomy and director of the Princeton Observatory, which he led for a quarter of a century until 1979. In 1985, he received the Crafoord Prize of the Swedish Royal Academy of Sciences, which is at the level of the Nobel Prize for those areas not covered by Nobel. Spitzer's researched in four major areas: interstellar matter, stellar dynamics, astronomy, and plasma physics, which he studied up to 1966.



Lyman Spitzer (right) with the American astronomer and Princeton University director Henry Norris Russell (* 1877; † 1957) who demonstrated spectroscopically that the Sun is mostly made up of hydrogen in 1929³²²³

Teller picked up Rosenbluth to help Teller's H-Bomb projects. Following the International Plasma

Physics Seminar from 5 to 31 October 1964, Marshall Nicholas Rosenbluth (1927 Albany, New York-2003 San Diego, California) led a plasma physics program at the International Center for Theoretical Physics in Trieste, thus affecting the Slovenians across the Italian border. In 2002, he received the third prestigious Alfvén's Award for outstanding contributions to plasma physics from the European Physical Society.

29.2.7 *Continuing Langmuir's Research Into Plasma Fluctuations*

The fluctuations in plasma did not allow much practical use other than the "plasma oscillator" described by the expert in sputtering Gottfried Karl Wehner (Fred, 1910 Bärenwalde 100 km southeast of Dresden-1996 Gauting 20 km southeast of Munich) at Wilbur Wright Air Force Field in Dayton, Ohio in 1950. Wehner began his studies of plasma as PhD student of Winfried Otto Schumann at Technical University of Munich and they both joined Wright-Patterson Air Force Base in Ohio by secret USA at Operation Paperclip. Otherwise, the study of the occurrence of fluctuations in plasma has a great scientific significance.

In 1952, Gabor calculated the rate of energy exchange between individual electrons and the entire spectrum of oscillations of plasma in the discharge, assuming an equipartition of energy between the various modes of plasma fluctuation. With too little energy transfer, he could not describe the phenomena that led to the concept of plasma fluctuations being introduced. It turned out that the modified theory explained much less than the original Langmuir's theory. The aged GE's counselor Langmuir was not yet a scapheap as a godfather of plasma.

So, Gabor returned to the original assumption of the existence of strong coherent, almost uniform frequency fluctuations within the discharge. Gabor's first doctoral student at Londoner Imperial college the son of escaped Jewish jeweller sir Eric Albert Ash (* 1928 Berlin) and Gabor's later PhD student E.D. Dracott assisted him at Imperial college to verify his assumption by sending a special electron beam through the discharge to the fluorescence display in 1955. They found that there are surprisingly high fluctuations in the plasma amplitude in the positive ion layer, which separates

³²²² Spitzer, 1997, 3, 505.

³²²³ Stroke, 723.

the plasma from the isolated wall. Such fluctuations are not in the plasma itself; therefore, they considered the influence of the plasma boundary and the boundary layer on plasma fluctuations, with which Bohm and one of his first graduate students at Princeton Eugene P. Gross (1926 New York-1991 Boston) supplemented the older Vlasov's assumptions in Princeton in 1949.³²²⁴

One of Bohm's and Gross's predictions was that oscillations were caused by electrons sent through a homogeneous plasma. Their assumptions were supported by experiments of Harrison J. Merrill (1913 Preston, Idaho-2008 Reston, VA) and Pupin's graduate student Harold Worthington Webb (1884-1974) of Columbia university published a decade earlier. With improved technique, they localized plasma fluctuations and established the relationship between oscillation and strong scattering, which didn't succeed in Langmuir and Tonks's lab in 1929.

The results of Merrill and Webb were analyzed by Richard Quintin Twiss (1920 Simla in North India-2005) in 1951. However, the agreement between experiments and theory was not indisputable, since in Merrill's and Webb's measurements the electron beams came into plasma through conus shaped sleeve formed by ions.

To overcome the doubts, Duncan H. Looney and Rumford's biographer Sanborn C. Brown (1913 Beirut-1981 Henniker, N.H.) experimented without their tube-shaped covering at MIT lab of electronics between 1952 and 1954. They did not detect the fluctuations in plasma seemingly predicted by Bohm and Gross. Hence, the dispersion laws were systematically analyzed and interpreted. In 1958 J. E. Drumond and Marshall Nicholas Rosenbluth's collaborator at General Atomic Division of General Dynamics Corporation, John Jay Hopkins Laboratory for Pure and Applied Science in San Diego David B. Chang showed that Bohm's and Gross's law of scattering predicts more amplifying than fluctuations. The same conclusions were already noted by Pierce with different methods. Looney and Brown probably did not notice any gain due to losses in their measuring system.

³²²⁴ Gabor, 1951, 216.

In a similar experiment, the Soviet researcher of plasma accelerators R. A. Demirkanov obtained a strong interaction between the modulated jet and plasma. A rare UFO researcher Peter Andrew Sturrock (* 1924 Stifford in Essex) showed that the diameter of the electron beam in the experiment of Looney and Brown was much smaller than the wavelength in plasma, and it did not fulfill with the condition of Bohm and Gross on an infinitely narrow jet. The theory of dispersion of waves and plasma was published by GJ Budker in 1956 at CERN (Fig. 29-8).

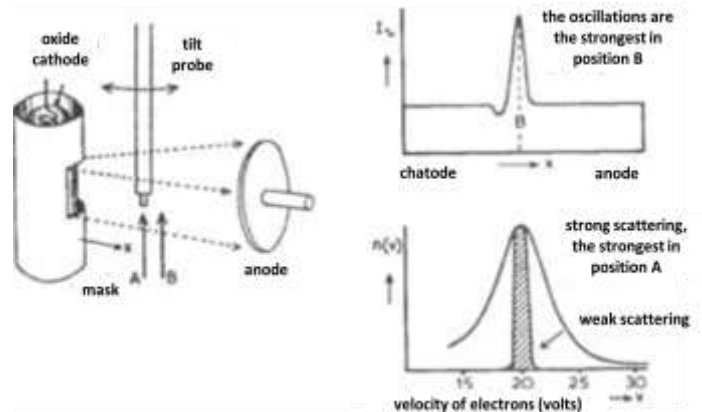

Figure 29-8: Merrill and Webb's experiments with localization of plasma fluctuation in 1939³²²⁵

The basic problem of plasma physics was the interaction of individual electrons with others in the ionized gas. In 1951 and 1952, Bohm and his PhD student David Pines (1924 Kansas City-2018 Urbana) studied plasma fluctuations. The other main problem of plasma research was the "escaping" electrons in thermonuclear devices. Rapid electrons interact strongly with plasma and cause high frequency instability, amplification, or oscillation.

Another, equally important problem is the interaction of plasma fluctuations with electromagnetic field. Plasma fluctuations should explain the irregularities associated with the behavior of electrons in arc discharges. The existence of these fluctuations was supported by the discovery of radio waves of approximately relevant frequencies emitted by the arc discharges. However, the theory of oscillation has shown that these waves are longitudinal and do not radiate.

³²²⁵ Gabor, 1951, 210.

Tonks and Langmuir also predicted transverse waves in plasma, but these methods of propagation did not affect other plasma fluctuations. Therefore, it was necessary to consider the influence of edges or non-homogeneity, which combine both types of waves. Such theories were developed by N. G. Denisov at his PhD in Gorkovsky University (Горьковский университет, today Lobachevsky State University of Nizhny Novgorod) in 1954, by Spitzer doctoral student at Princeton George B. Field (* 1929 Providence, Rhode Island) in 1956 and by the collaborator of the Jewish atheistic Nobel laureate Vitaly Lazarevich Ginzburg named Vladimir Vasiljevič in 1956. Another important way of coupling the energies of plasma fluctuations with a radiation field allows the formation of a static magnetic field in plasma.

Plasma physics initially considered the exchange of energies between an individual electron and the collective motion of many particles. The same happened to its related quantum physics of plasma.

In 1934, Bloch expanded his research of power of stopping the charged particles by quantifying the excited states of Fermi gas. He did not describe the particles with the holes and excited states, but as states of fluctuations of gas resembling the sound.

In 1949 Bohm in his theory of superconductivity assumed that the fluctuations of plasma in a metal are not easily disturbed with the external forces of perturbation. The prediction was proved by Sin-Itiro Tomonaga of the Tokyo University in 1950 and 1958. After 1954, they began to differentiate between the collective and individual excitations of particles that the fast electrons cause in metals. They measured eigen-energies and intensities in dependence on the angle of scattering of the incident electrons, the impurity in the target and the temperature.

Like the classical physics, the quantum plasma physics has also a problem of the interaction of plasma fluctuations with electromagnetic fields, which was investigated by Heisenberg's postdoc student Richard Alan Ferrell (1926 Santa Ana-2005) at Naval Ordnance Laboratory in the United States in 1958 and 1959.

29.2.8 Nuclear Fusion

As most of the discoveries in physics of the 20th century, the plasma physics have also developed from the study of discharges in dilute gases. Soon it interfered with the substance in space and became particularly interesting for astrophysics, which until then was not explicitly interested in cathode ray tubes research. Thus, the discoveries of plasma physics touch upon the very foundations of the knowledge of the world which surrounds us.

The plasma makes 99% of all substances in stars and between them, while on Earth it is rare. The firing and spark at normal pressures were well understood only in the middle of the 20th century. The translation of electricity through diluted gases, which appears in the high parts of the atmosphere as a northern glow, began to be intensively

Sin-Itiro Tomonaga of Tokyo studied in Kyoto and completed his studies at Heisenberg's class in the University of Leipzig between 1937 and 1939. Their collaboration was a part of the militarization of both their countries on the eve of WW2. In 1946, Sin-Itiro Tomonaga developed a mathematical description of the interactions between photons and electrons, and he independently developed the theoretical foundations of quantum electrodynamics by 1948. Similar ideas were separately developed by Richard Feynman and Julian Schwinger (1918-1994) in the United States, therefore, Sin-Itiro Tomonaga shared the Nobel Prize in Physics with them in 1965. In 1950, Tomonaga considered fermions as quantum of sound.



Sin-Itiro Tomonaga (* 1906; † 1979)³²²⁶

³²²⁶ Schweber, Treiman, Phys. Today (December 1994) 59.

explored in the second half of the 19th century.³²²⁷ From the same time there are also the first explanations of meteors, another example of the appearance of plasma in the upper layers of the atmosphere. The Polar Aurora Borealis also attracted interest among Slovenes, although it was more rarely seen in their latitudes, for example, on 24 and 25 October 1870 and on 14 February 1892, when it was described by Josip Torbar (1871) and Simon Šubic.

The magnetohydrodynamics, or, better, magnetofluidodynamics deals with the motion of conducting liquids in magnetic fields, thus combining electrodynamics and hydrodynamics. The astrophysicists had been involved in magnetohydrodynamics since the beginnings of physics of radiofrequency plasma. They studied the "hydrodynamics of Sun" and the source of the magnetic fields of the Earth and the Sun. The treatment of currents through the Earth's core has evolved into the study of the motion of an incompressible conductive field, which has become the fundamental problem of magnetohydrodynamics. Practically, it is used primarily in "magnetic self-focusing systems", the basis of the operation of fusion reactors. Physics of plasma has emerged as a special branch of science later than other branches of science. The delay has brought some advantages, since it is precisely from the research of plasma and fusion that we expect the solution of the energy crisis due to the supposed exhaustion of fossil fuels mostly stored outside westerner domains. The rise in the price of coal and other imported fossil fuels has directed the British and many other replacements of the thermal power stations with nuclear plants.

The fusion would, of course, have priority over fission nuclear power stations, because its fuel deuterium as is very cheap. By using nuclear fusion reactors, plasma physics promises a solution to the energy crisis and at the same time reduces the pollution of the environment.

The artificial Sun of fusion is almost naturally inherent to humans. In the early 1970s, following Natan Aronovich Yavlinsky's (Javlinsky, Yavlinskii, Натан Аронович Явлинский, 1912 Kharkov-1962) and Ksenia Aleksandrovna Razumova's (Ксения Александровна Разумова, Xenia Razumova, * 1931) success at the

TOKAMAK T-3 in the Soviet Union, it seemed that controlled fusion of nucleuses was ahead. Surveys were designed by TOKAMAK for individual households... However, decades later, it seems that the solution is not so close because its final designs are always supposed to appear a dozen years ahead.

Majority of plasma surveys were devoted to the control of the fusion energy, which is supposed to be used as an inexhaustible energy source. This problem has attracted most of the magnetic fusion investigations between 1945 and 1958 as well as later the research of Inertial confinement fusion using lasers.³²²⁸

We developed two basic types of thermonuclear reactors. In the first, whose oldest representative is TOKAMAK, we need external energy only to trigger a thermonuclear reaction. For the second type, α particles produce too little energy to maintain the reaction, so we must supply energy from the outside.

29.2.9 *Magnetic Traps and Stellarators*

In 1952, Leontovich's Moscow helper Vitaly Dmitrievich Shafranov (Виталий Дмитриевич Шафранов, 1929 small village Morvinovo 100 km east of Moscow-2014 Moscow), and the Jewish relative of Julius Robert Oppenheimer Martin David Kruskal (1925 New York-2006 Princeton) at Plasma Physics Laboratory in Princeton independently from each other found the conditions for stabilization of plasma with a magnetic field. They researched during the collusions of the Cold War. The experiments in the Soviet Union were conducted under the direction of Tamm's PhD student Igor Nikolaevich Golovin (1913 Moscow-1997 Moscow) and Natan Aronovich Yavlinsky. The Jew Gersh Itskovich Budker (Герш Ицкович Будкер, Andrey Mikhailovich, 1918 Murafa in Ukraine-1977 Akademgorodok) suggested that a "tape" of plasma be inserted into another external magnetic field directed along the axis. The interaction of this field with the plasma flow results in a force in the direction of the plasma thread. If we correctly choose the size of the average field, this force can compensate for the effect of ballooning.

³²²⁷ Penning, 1957, 1.

³²²⁸ Stroke, 742.

The nonstationary aspects of plasma had forced researchers to find other ways to hold plasma using magnetic fields. In 1952, Budker in the Soviet Union and independently of him Herb York and Dick Post in Livermore in USA, produced a trap in which the long-term plasma retention was used by the reflection of charged particles from the field with increased induction of the magnetic field. A simple trap was in the shape of a bottle with two necks. Induction of the magnetic field is higher in the throats than in the middle of the bottle trap, where bottle was used by USA terminology and trap in Soviet slang. This increased induction consists of a magnetic plug preventing the plasma from escaping from the trap. That is why Budker called his construction of a trap with "magnetic stoppers" "probkotron". In the United States, the same kind of trajectory was called a "magnetic mirror system."

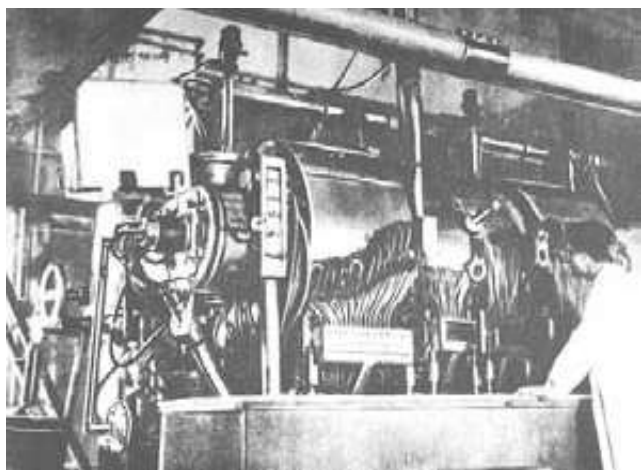

Figure 29-9: Photo of Ioffe's "PR-1"³²²⁹

In 1953, Budker assumed that the mass of particles was changing during the passage through the trap, which was experimentally detected by the device "OGRA"³²³⁰ in the Soviet Union and by the Oak Ridge Direct Current Experiment "DCX" in Tennessee.

OGRA was built at the Kurčatov Institute for Atomic Energy in 1958. It had a vacuum vessel of 1.4 m in diameter and 12 m in length. The magnetic field in the middle of the trap reached up to 0.5 T and at the ends up to 0.8 T. In such large devices, a vacuum of 10^{-9} mbar could already be achieved.

³²²⁹ Arcimovič, 1964, 336.

³²³⁰ "Odin Gramm Neutronov v Sutki", gram of neutrons per day was just enough for thermonuclear reaction.

Another much smaller trap "PR-1" operated under the guidance of M.S. Ioffe at the same Kurčatov institute (Figure 29-9). The diameter of the vacuumed vessel with a pressure of down to $0.8 \cdot 10^{-7}$ mbar was 0.5 m, and the distance between the magnetic stoppers was about 1 m. In the middle of the room there was a magnetic field of 0.2 T density and in the stoppers, there could be even 3.4 T. Even before the attempts at "PR-2", in 1957 B.B. Kadomtsov in the Soviet Union and Marshall Nicholas Rosenbluth (1927-2003 San Diego) with Conrad Lee Longmire (1921-2010 Santa Barbara) of Los Alamos in the US were predicted that plasma not only runs away through the stops in the traps of the magnetic field of, but also transversally through the magnetic field (Figure 29-10).³²³¹

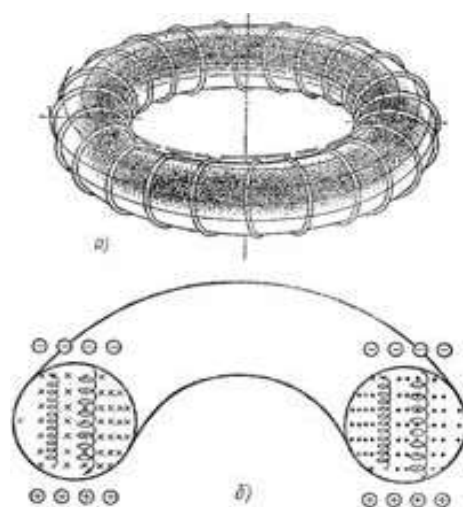

Figure 29-10: Sketches of magnetic traps³²³²

In March 1951 the Argentinian President Peron, the husband of beautiful Evita of Madonna's movie, announced that his researchers successfully carried out a controlled thermonuclear reaction. The news made Spitzer reflect deeply, while he just went to his family skiing. He was thinking during his long waiting lines on the ski lift and, after returning to Princeton, he designed a stellarator.³²³³ The Atomic Energy Commission immediately paid a year of his theoretical studies of a stellarator to obtain energy from thermonuclear reactions using deuterium or 2 deuterium and tritium.

After theoretical research, experiments were started under the leadership of James Van Allen (1914-2006) at the University of Iowa, who first

³²³¹ Arcimovič, 1964, 251, 330, 340–342, 391

³²³² Voronov, 1985, 67.

³²³³ Star knot.

submitted a simple model A with a glass vacuum container of diameter 5 cm. Van Allen later became famous for his radiation belts. The model B followed with the vacuum tank of same size where Van Allen reduced the diameter of the plasma to 2.5 cm and the magnetic field to 5 T. With ultrahigh vacuum he reduced the flow of impurities from the walls and obtained good agreement with the predictions of magnetohydrodynamics. It seemed that success was just near ahead. That's why they started to make up four times bigger model "C", which should follow the model "D" in the form of a usable reactor.

Unfortunately, more detailed experiments showed that the plasma confinement time in the "B" model was unexpectedly short, of order of only 10^{-4} s. Therefore, the Atomic Energy Commission stopped the program after the "C" model. Since the work was already underway, experiments were started anyway in May 1961. They achieved one order of magnitude higher plasma confinement time.

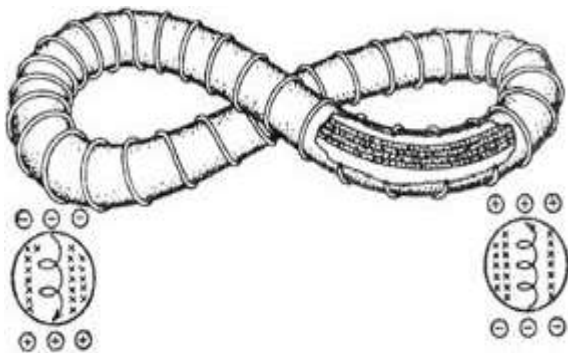

Figure 29-11: Sketch of stellarator³²³⁴

In stellarators, the problems in toroidal magnetic fields were removed with a magnetic retention design in the form of a "8"-shaped plasma (Fig. 29-11). The magnetic forces from a thin magnetic coil, wrapped around a vacuum vessel shaped as number 8, directed hydrogen ions into the vessel. An unusual vessel was designed at Princeton University to prevent energy losses by hydrogen ions' colliding with the wall. The charged pick particle moved in one loop in the clockwise direction and in the opposite direction in the other loop. The particle deviation from their preferred orbits was luckily nullified.

³²³⁴ Voronov, 1985, 68.

In 1954, at the University of California, then leader of the production of American hydrogen bombs Teller noted that that form of stellarator is not resistant to the excitation of plasma along the helical line. The problem was later resolved by Spitzer, who led a plasma physics laboratory in Princeton from 1953 to 1966, initially under the secret name "Matterhorn Project" to make a joke on earlier Manhattan project.³²³⁵

Since no vessel can keep something as hot as plasma, it had to be kept in a limited space with magnetic fields in a "magnetic bottle". Of course, the plasma should not escape from the bottle, as it would cool down on the walls of the vessel and thus lower its temperature needed for fusion.

At the end of the 1950s, the United States guys reached around 10 million degrees. Similar attempts have been made in the Soviet Union, Great Britain, Sweden, Germany, Japan and elsewhere. As pioneers of the new field of research the Brits used their particularly large devices. Initially, deuterium was preferred as the reaction substance, and later tritium which posed greater radiation problems. When using pure deuterium, where two-thirds of the energy is carried by the charged particles, it seemed possible to turn all the energy of particles straight into electricity. Like the piston in the steam engine, we can imagine a moving plasma that operates against a magnetic field, and an electric current that takes away energy.

In the mixture of deuterium and tritium, most of the energy is taken by neutrons. The liquid lid barrier can be used to absorb neutrons and to change their energy into heat; and the decay of lithium produces useful tritium atoms at the same time. The fusion energy of the nuclei is then used to heat outside the plasma, which is then used again to produce even more energy.

In 1952, the Soviet Union guys found that at certain conditions strong "pinch" in the diluted deuterium characteristically source strong radiation neutrons and X-rays.

Bennett's "pinch"-effect has become a constant topic of astrophysics and geophysics research, and in the second half of the 20th century" also of fusion which was not easily to controlled or stabilized. In 1950, the Soviet Union and the USA proposed the use of Bennett's discovery of

³²³⁵ Spitzer, 1997, 445.

magnetic thermal insulation of plasma for controlled thermonuclear fusion of nuclei.

Between 1950 and 1951, the "pinch"-effect of deuterium was researched on the state level in the Soviet Union, the United States and the United Kingdom. In the US, the project Sherwood named after friar Tuck (in fact James Leslie Tuck) and Robin Hood's residence has been set up to develop a controlled output of fusion power. In 1951, the research began with little support, but the project was given as much as \$ 40 million a year until 1959.

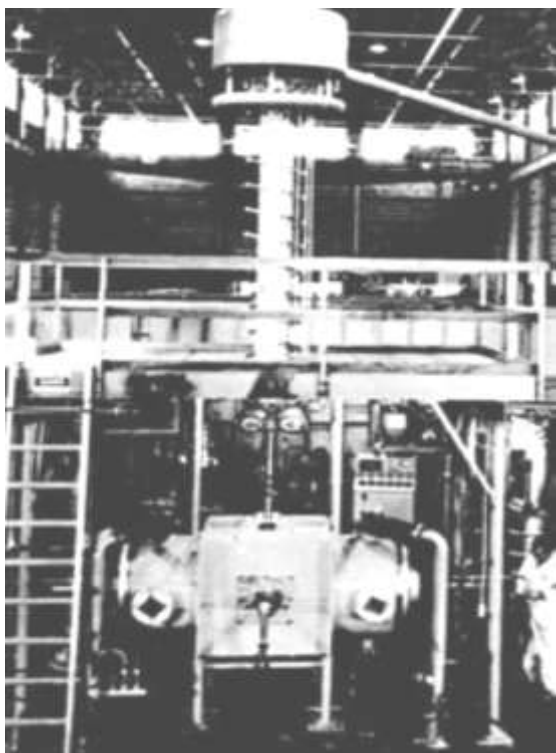

Figure 29-12: Photo of the fusion research facility in Oak Ridge³²³⁶

A whole series of experimental devices for exploring the "pinch"-effect were put in a scientific laboratory in Los Alamos. James Leslie Tuck (1910 Manchester-1980) Gamow jokily baptized "Perhapsatron" a funny device built in 1952. In it, the hydrogen ions circulated in a cathode ray tube shaped like a donut, and the electric current pulled them together into a narrow column inside the tube. Plasma was limited only by the magnetic field generated by the plasma current itself, which did not enable the desired stability. In lab of Laurence Livermore University 44 miles east of San Francisco in California, they chose different

way of solving fusion problems, called "magnetic mirrors". Instead of space in the form of a donut, they used a straight tube; hydrogen plasma was trapped by strong magnetic fields and "repelled" back from the end of the tube to the inside. In the National Laboratory at Oak Ridge, fusion was undertaken by launching the deuterium molecules down into the reaction vessel. They were ionized there with an electric arc and then influenced by magnetic fields (Figure 29-12).

29.2.10 TOKAMAK³²³⁷

The structure of the magnetic field in TOKAMAK (Figure 29-13) resembles the stellarator; only we do not get rotation of the magnetic field lines with the outer wrapper of the helix, but with the flow that flows along the plasma. Closed magnetic surfaces are alike in both devices.

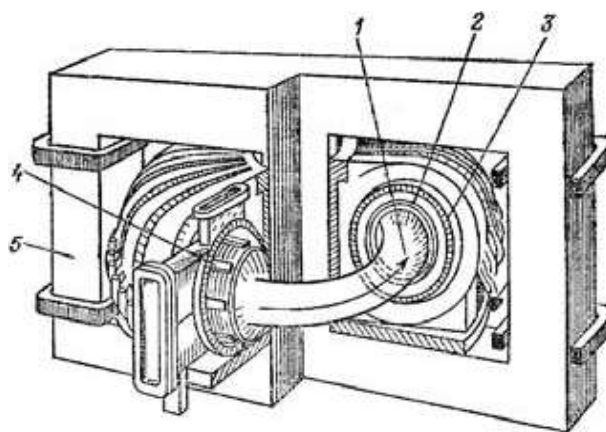

Figure 29-13: TOKAMAK³²³⁸

TOKAMAK is the simplest and best-studied design for limited controlled plasma, since only the simplest toroidal field, plasma and current are required. The first TOKAMAK was developed by Lev Andreievich Artsimovich's (Arcimovich, Arcimovič, Лев Андреевич Арцимович, 1909 Moscow-1973 Moscow) group at the Kurchatov (Kurčatov) Institute of Atomic Energy (Национальный исследовательский центр «Курчатовский институт» previously Институт атомной энергии (ИАЭ) имени Игоря Васильевича Курчатова) in the Soviet Union in 1956. They reached temperatures of 15 million degrees.³²³⁹

³²³⁷ In Russian language: "Toroidal'naja Kamera s Magnitnymi Katuskami".

³²³⁸ Voronov, 1985, 87.

³²³⁹ Tarasov, 1985, 164.

³²³⁶ Lapp, 1960, 170.

Initially, they used the term "Toroid in the magnetic field (TMR)" for ТОКАМАК. In 1958, T-1 was assembled with the stainless kind of steel container, but only reached a few thousand degrees and did not exceed the potential barrier. In practice, the same T-1 and T-2 had a 125 cm diameter vacuum container at a maximum magnetic field strength of 0.8 MA/m.³²⁴⁰

After the numerous monographs by leading researchers,³²⁴¹ plasma physics has become a recognized research area on both sides of the "iron curtain." Another distinguished field of physics.

The antagonist of the biologist Lysenko (Трофим Денисович Лысенко, Трохим Денисович Лисенко, 1898-1976), **Lev Andreevich Arcimovich** (Arcimovič) from Moscow studied in Minsk where his parents escaped during the revolution. Between 1930 and 1944 he studied at the Leningrad Physical-Technical Institute of the National Academy of the Soviet Union, and then at the Kurčatov Institute of Atomic Energy. In 1936 he and his colleagues demonstrated the preservation of the impulse in the annihilation of positron and electron. From 1951 he led the research of thermonuclear synthesis in the Soviet Union. In the following year, together with Leontovich (Leontovič) from Moscow and colleagues, he discovered neutron radiation in a high-temperature plasma. In 1955, Geneva hosted the first international conference on the peaceful use of atomic energy, which did not yet discuss fusion. In 1956, after the February speech of Nikita Khrushchev against Stalinism at the 20th Congress of the Communist Party of the Soviet Union, Kurchatov lectured on fundamental thermonuclear research at the Harwell Atomic Center in England near Harwell in Oxfordshire, thus revealing the secret curtain of the mystery. Two years later, the exchange of experience continued at the 2nd International Conference on the Peaceful Uses of Atomic Energy under the auspices of the UN in Geneva, where Spitzer first publicly presented his stellarator. In 1961, the researchers met in Salzburg at the 1st International Conference on Plasma Physics and Controlled Nuclear Fusion.

³²⁴⁰ Arcimovič, 1964, 211.

³²⁴¹ Spitzer (1956, 2: 1962), T. G. Cowling (1957), Chandrasekhar (1960), Alfvén (1950, 2: 1963), Arcimovič (1961, 2:1964).

In the early 1950s, Nikolai Vasiljevič Filippov's (Николай Васильевич Филиппов, 1921 Moscow-1998 Moscow) invention remained one of the real variants of the solution of the thermonuclear problem, but Filippov died after a winter ski trip along the Moskva River. When it became clear that one of the main paths of energy loss in these discharges was associated with the exclusion of admixtures, the academician Arcimovich presented a replacement of the wall of the discharge vessel with copper. He assumed that high thermal conductivity of the copper would reduce the surface heating by contact with the plasma and diminish the flow of admixtures into plasma. For safety purposes, the side wall of the room was electrically connected to the cathode. When the high-voltage pulse was applied on the anode, the discharge illuminated the room. The researchers were surprised at the extraordinary phenomenon, since the change in the sidewall material produced huge increase in the number of output neutrons. Unlike conventional discharges, the neutron pulse in this system began to retain stability. V. Filippov found the source of neutrons in a very small area on an axis between anode and a cathode of about 1 cm in diameter by lead-collimator with a small aperture and with an internal neutron counter. It seemed that, during the release of such composite charges, under the pressure of the magnetic field plasma is directed from all sides to the center of the system.

At the point of symmetry, the "streams" of plasmas collide and form a surface thickening from which neutrons emerge. This area, and with it the whole contained system was called a "dense plasma focus (DPF)". The plasma flow was indeed collected along the axis like the light beams were collected at the focal point of the lens.

In 1965 at the 2nd International Conference on Plasma Physics and Controlled Fusion of nucleuses in England, Bohm described the relationship between the time of existence, the temperature and the magnetic field size in plasma, which caused the pessimism about the operation of the thermonuclear reactor because Bohm predicted the decreasing of the time of existence of plasma by increasing its temperature. Ksenia Aleksandrovna Razumova's Tokamaks seemingly proved Bohm's error.

In 1961 the T-3 was designed in the Soviet Union with a toroidal container of diameter 200 cm,

where they started experiments in the summer of 1962. A smaller "plasma diameter" 40 cm was achieved with two vacuum pumps at a pressure of 4×10^{-8} mbar at a maximum magnetic field strength of 3 MA/m. In 1968, the first quasi-stationary thermonuclear reaction was obtained and at the 3rd International Conference on Plasma Physics and Controlled Fusion of Nuclei in Novosibirsk, the guests were told that the Soviets were able to exceed the radiation barrier, under which almost all the energy inputs were emitted by was a elimination of impurities. The TOKAMAK T-3 was expected to reach ten million degrees, almost ten times as high as in the best stellarators. The Americans did not want to believe this at first, so they started a discussion on the methods of measuring the temperature and other properties of plasmas at the conference and tried to find a mistake in the measurements of their Soviet counterparts. In the following year, the English themselves measured the temperature in T-3 and gained even higher value. That's why the US stopped developing stellarators, which seemed like a blind alley.

The largest USA stellarator model C was transformed into spherical Tokamak (ST). They removed the screw coil and inserted a larger vacuum container.³²⁴² In 1970 the experiments began and were reported next year at an international conference on plasma physics and controlled fusion of nuclei in Madison. At MIT, TOKAMAK was set up, which was somewhat smaller than the Soviet T-3, but it had almost three times stronger magnetic field of 9 Tesla. The T-3 model, according to the type of modernization called T-3a and T-4, operated until 1978.

The more recent successes of stellarators in the Soviet Union, where they first set it up at the Physics Institute PN Lebedev at the Academy of Sciences in 1962, caused their re-establishment, since at that time they had around 20 TOKAMAKS and no stellarators. That's why the Princeton Large Torus TOKAMAK PLT, which reached 60 million degrees, was transformed into a stellarator. In the middle of 1983, the National Research Laboratory in Oak Ridge received \$ 15 million for a stellarator.

In 1982 in TOKAMAK T-10 in the Soviet Union ions in the axis of the filament, heated by jets of

fast atoms, already reached "energy lifetime" of 0.1 s and a temperature of 80 million degrees.

In the next generation of TOKAMAKS, the T-15 in the Soviet Union, the TFTR in the United States,³²⁴³ JET in the European Union and JT in Japan achieved plasma parameters close to those required for thermonuclear reactor.

In 1957 the Englishmen John David Lawson (1923 Coverntry-2008) proved that the product of the density plasma ions and the confinement time exceeding $3 \cdot 10^{20}$ s/m³ is needed to maintain a thermonuclear reaction after the end of external warming.

In 1994, the Tokamak Fusion Test Reactor (TFTR) in Princeton had already come close to Lawson's criterion for the product between the density of ionized nuclei and confinement time, which, according to today's calculations, should exceed $2 \cdot 10^{20}$ s/m³. They reached temperatures of up to $4 \cdot 10^8$ K, but not in the same experiment. TFTR began operating at the end of 1982, but later the Princeton Plasma Laboratory went into crisis, while reducing former 1800 employee to only 800 in 1984.

Later it turned out that the price of the test reactor would exceed the possible budgets of individual countries. Therefore, in 1985 Michael Gorbachev submitted to Ronald Reagan the proposal for the joint production of TOKAMAK. Based on this agreement, researchers from the European Community (with Switzerland), Japan, Russia and the United States meet at intervals in Garching north of Munich in Germany in 1987. In April 1988, they decided to build a TOKAMAK ITER³²⁴⁴ jointly at French Provence.³²⁴⁵ The toroid plasma should be about 5 m wide, 10 m long and the diameter around the toroidal center line should be about 50 m. The concept for ITER was completed in 1990.

At that time, Japan began to build their stellarator type device with a smaller radius of the vacuum vessel. Their design was much smaller than ITER, but it enables more direct comparison with TOKAMAKs.

³²⁴³ Tokamak Fusion Test Reactor in Princeton.

³²⁴⁴ International Thermonuclear Experimental Reactor.

³²⁴⁵ Spitzer, 1997, 472.

³²⁴² Spitzer, 1997, 445, 472.

29.2.11 Laser Method

The nuclear fusion can be controlled by a pulse method without the use of magnetic retention of plasma. The compacted density of deuterium and tritium with a diameter of about a millimeter diameter can be heated in a very short time, in which it cannot yet decompose. This creates a very high pressure, which enables more intense heat exchange between electrons and protons. We use well-focused, strong laser radiation, which must simultaneously heat the compression all sides during the time of the order of the nanosecond. The method shows some technical and structural problems, for example, how to use profitably the obtained energy of neutrons (Figure 29-14).³²⁴⁶

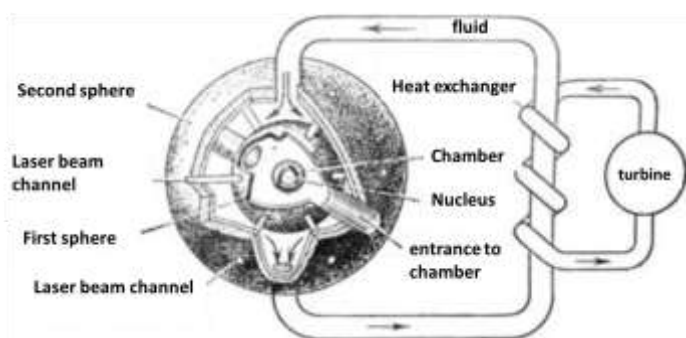

Figure 29-14: Sketch of a laser thermonuclear reactor project³²⁴⁷

The first laser thermonuclear fusion was achieved in the laboratory of Basov at the Kalmar (Кальмар) plant at Physical Institute P. N. Lebedev at the Soviet Academy of Sciences in 1968. In 1964, Basov received half of the Nobel Prize in Physics for Quantum Electronics Research, which led to the invention of lasers and masers. In 1995 in the laboratory of the University of Lawrence Livermore in California, they produced the most powerful (10^{15} W) laser needed for the research of fusion.

29.2.12 Uninterrupted Plasma Heating: Continuous Laser Method

In the Laboratory for physics problems in Moscow led by former Ioffe's student and Rutherford's collaborator Kapitsa and his collaborators

developed the continuously heated plasma method in 1969.³²⁴⁸

Unlike TOKAMAK and laser methods, Kapitsa's group randomly found a method for obtaining "flaming" plasma. As early as 1950, they produced a powerful high frequency continuously working generator called "Nigotron" (ниготрон) named by his summer house at Nikolina Gora (Николина Гора) west of Moscow. In one of the models, the wave was passed through a ball of silica filled with helium at a pressure of 133 mbar. In the sharp borders, the sphere radiated for few seconds, and in one place it melted.

In 1955, they published a hypothesis that even the mysterious ball lightings in storm clouds appear after ordinary thunder because of the high pressure's fluctuations that deliver the energy to glitter the sphere. In March 1958, the plasma parameters with a spherical resonator filled with helium at normal pressure began to be measured. They received a freely falling charge of the oval shape formed in the region of the maximum electric field and slowly moving along the circle and coinciding with the lines of force.

The most interesting was plasma radiation in hydrogen or deuterium. For small power discharges, it had no strictly defined limits, and the lights were diffused. By greater power the luminosity enlarged, the diameter of the discharge increased, and a strictly separated core shaped as a thread formed in the interior.

In the initial experiments, the discharge was triggered with a power of up to 15 kW at a pressure of 5 bar. The greater the pressure, the more stable the discharge was, and the more pronounced the shape of the plasma core. The study of the plasma conductivity including the active and passive spectral diagnostics found that the electrons at the center of the discharge have a very high temperature of several million degrees. At the boundary of plasma, a large temperature gradient was created, which can only be achieved by a well-temperature insulated layer. Initially, such kind of gradient aroused doubts until they found a physical explanation for it. At the boundary of "burning" plasma, a double electric layer must be formed, from which the electrons are reflected without loss of energy. Similarly happens

³²⁴⁶ Kapitsa, 1981, 118.

³²⁴⁷ Voronov, 1985, 155.

³²⁴⁸ Kapitsa, 1981, 19.

when the plasma is surrounded by a layer of dielectric, such as glass or porcelain. Due to the double electrical layer on the surface of the dielectric, even at higher pressure the temperature of electrons might be more than 10,000 degrees, without perceptible heating of the walls of the container. The model of such thermal plasma insulation was first described by Langmuir. The electrons in the collision with dielectrics penetrate deeper than the more cumbersome ions. The volume charge density of the electrons therefore reached deeper than the surface charge of the ions, and reverses the electric field of the double layer, so that the fast electrons are elastically repelled from it.

In the 1970s, the microwave diagnostic method was greatly improved, so that they could measure the distribution of the density along the radius of the filament and its dependence on the magnetic field and pressure in a plasma with an accuracy of 5%. The conditions that led to the stabilization of plasma were also explained. They increased the power brought to the filamentation for several times and raised the electron temperature to 50 million degrees. This would allow fusion of deuterium with tritium without the addition of a plasma heating with magneto-acoustic oscillation if it was possible to provide a temperature equilibrium between ion and electron gas. This would greatly simplify the construction of the thermonuclear reactor.

Although the construction of Kapitsa's reactor for continuous plasma heating was very simple, Kapitsa doubted whether it could be used for controlled fusion of nucleuses. The convection processes of heat exchange cannot be assessed by theory, and therefore Kapitsa had to investigate it experimentally at the end of the 1970s.

Maxwell first described the possibility of air convection around the radiometer due to internal stresses caused by temperature gradients near the blades of mill. Shortly before Maxwell's death, his research of Crookes' radiometer showed that the internal tensions are proportional to the viscosity square and the outflow of the temperature gradient.³²⁴⁹ Viscosity is proportional to the mean free path, which is close to 10^{-4} mm for ordinary gases at ordinary pressures. For small temperature

gradients, the internal tension is unmeasurably small.

In the case of plasma, the average free path extends to a centimeter, and the gradient temperature is large. That is why the internal tension in plasma by Maxwell's equation could be ten times larger than in the gas, and it can cause convection current and turbulence in plasma. The magnetic field can affect the nature of this phenomenon. Unfortunately, the additional action of the electric field completely disables even a rough estimation of the power of the convection necessary for efficient heating of the ions. Similarly, we can mask the possible increase in the critical plasma size of the reactor by increasing the dimensions of the reactor without proper gains of energy. The latter, of course, would call into question the economy of the construction of a reactor of this kind.³²⁵⁰

29.2.13 Future Research of Plasma and of Plasma Technologies

In the ideal limit without scattering, plasma is completely frozen in the field of magnetic forces. The real plasma is usually turbulent and complex, so that the research of its behaviour has become one of the key contributors to the development of nonlinear physics.

The years of troubles have prompted researchers to make a joking remark that the solution of the problems of the fusion reactor opens a new challenge to the newcomers in this field with ever more expensive solutions as a moving target that is constantly running away. The solution to the problem of fusion should be "always 20 years later". However, there is no doubt that a 1 GW capacity fusion reactor can be built, although many problems remain open. The basics of plasma physics in TOKAMAK are well known, but much research is still focused on understanding the detailed nature of microturbulences that cause anomalous transmission of energy and fuel. The fundamental problems of the Earth's dynamics and the influence of magnetic fields on cosmological development remain open. During the research of fusion, new unplanned plasma technologies were emerging. The successes are mostly the results of the "Edison mode" of experiments and errors

³²⁴⁹ Maxwell, 1879, 231.

³²⁵⁰ Kapitsa, 1981, 127–128.

which really brings success, but only at highest costs.

A detailed understanding of the possibility of predicting turbulence and the behavior of fusion of plasma are important challenges of modern physics. The plasma becomes more and more important in the technology of welding, cutting, cleaning, and applying thin films of 2.5-5 μm thickness, sterilization, etc. The most important and most profitable is the use of plasma for etching, which was used for the first time in the production of integrated circuit (chip) in the late 1970s and became indispensable for production of VLSI.³²⁵¹ In 1990, the global plasma-processed industry generated revenues of around US \$ 1 billion.



Figure 29-15: Plasma etching devices³²⁵²

The advantage of plasma processes enables anisotropic removal of semiconductor, insulator or metal material. In plasma etching with reactive ions, rapidly erecting with fast ions is complemented by chemically-reactive interactions. Therefore, the etching is performed in the direction perpendicular to the surface. The procedure allows fast enough even etching of furrows in silicon with a thickness of 0.2 μm and a depth of 4 μm , which

cannot be carried out by liquid etching or other modern methods (Fig. 29-15).

Plasma is used in accelerators; with plasma spatially charged waves we produce very strong electric fields moving at a phase velocity close to the light. Thus, plasma is indispensable in all industries where the greatest amount of money circulates in the space research, accelerators, fusion, and computers.

29.2.14 Conclusion

Now we can observe our space environment with X-rays and γ - radiations that are mostly emitted by plasma forms. Traditionally, our knowledge of the universe came from the observation of the visible octave, later supplemented by radio frequencies and some views into the infrared. The space age allowed us to observe beyond the 'visible universe' also the 'universe of plasma' ... The relationship between visible and plasma universe is like the relationship between the visible and the X-ray image of a human... Like our visual image informs us about the surface of the celestial bodies, we are studying the plasma to learn about the structure of the space between the planets and, by extrapolation, of how the Solar System was once formed from small particles of plasma... The transition from 'visible universe' to 'plasma universe' is in some respects like the transition from geocentric to heliocentric cosmology 400 years ago. The latter is mostly attributed to Copernicus, but Galileo's use of the telescope may have been more important since it gave a lot of new material for observation. In fact, for 2000 years before Copernicus, Aristarchus of Samos submitted a heliocentric system, but he could not prove it without a telescope like the pharaoh Akhenaten (Echnaton, † 1334/35 BC), Han Yu Xi (虞喜, fl. 307-345), the Arabic Alpetragius (Abū Ishāq Nūr al-Dīn al-Bitrūyī, † 1205), the Persian Nasir al-Din Tusi (1201-1274) and the Kerala school predecessor of Tycho Keḷallur Nilakantha Somayaji (1444-1544). Similarly, the use of spacecrafts gives us a wealth of newly induced information calling for a new model of space.³²⁵³

Table 29-1 is a review of the Nobel and Crafoord awards received by leading plasma researchers.

³²⁵¹ Very Large Scale Integration.

³²⁵² Oehrlein, 1986, 27.

³²⁵³ Alfvén, 1986, 22, 23, 26–27.

Table 29-1: Nobel Prizes for Plasma Researchers

Year	Surname	Science	Area of Research:	
			Plasma	Other
1932	Langmuir	Chemistry	thin layer surfaces	
1947	Appleton	Physics	properties of ionosphere	
1962	Landau	Physics		liquid helium theory
1967	Bethe	Physics	physics theory of nuclear reactions that provide the energy of stars	
1970	Alfvén	Physics	magnetohydrodynamics and Plasma Physics	
1978	Kapitsa	Physics		Low Temperatures
1983	Chandrasekhar	Physics	Theory of the Structure and Evolution of the Stars	
1985	Spitzer	Astronomy (Crafoord Prize)	Interstellar Matter	

29.3 Slovenian Plasma: Sirk's Plasma and the Beginning of Physics at the University of Ljubljana

Boltzmann's transport equations were the basis of plasma research; Boltzmann himself did not actively cooperate there, except as a mentor of research of cathode rays with a huge electromagnet at the Viennese Physics Institute. Boltzmann's teacher was Slovenian, his wife too, and he also had many Slovenian PhD students. On 18 March 1906, Boltzmann advised the dissertation of Johann Radakovits (Radakovič, * 1877 Celje). Johann measured the conductivity of ionized air at various pressures as "not quite without scientific interest". J. Radakovits described the history of research of the properties of warmed air and, basically, outlined Nahrwold's work.³²⁵⁴ J. Radakovits taught at German communal Grammar school in Ostrava (Ostau) in Moravian Silesia in 1910/11. The other Boltzmann's student the Croatian Michael Radakovits (Radaković, 1866 Graz-1934 Graz) taught mathematics and physics at the university of Czernowitz (Černovice) as the member of commission for high school professors in 1911 while he corresponded greatly with Slovenian mathematician Plemelj. Michael Radakovits's chair of physics in Graz was taken

over by Schrödinger while one of Michael's sons belonged to the Viennese Mach's circle.

In 1880 in Graz the priest Ivan Svetina (1851 Breznica in the municipality of Žirovnica-1936 Žirovnica) defended his dissertation Natural sciences and philosophy: their mutual relationship and the limits of the knowledge that can be achieved through both (Naturwissenschaften und Philosophie: ihr gegenseitiges Verhältnis und die Grenzen der durch beide erreichbaren Erkenntnisse) with his advisors Boltzmann and neo-Kantian Alois Adolf Riehl (Aloys, * 1844 Riehlhof by Bolzano (Bozen); † 1924 Neubabelsberg by Potsdam). In 1885 in Graz another priest Frančišek Lampe (*1859 Zadlog between Idrija and Ajdovščina; † 1900 Ljubljana) defended his dissertation causality: a contribution to the theory of knowledge with the advisers Boltzmann and the philosopher-psychologist Alexius Meinong Ritter von Handschuchsheim (1853 Lvov-1920 Graz). Boltzmann's Slovenian Styrian PhD students include Josef Hoffmann's (* 1854 Ptuj) dissertation about geometry in its dependence on the masses contained in space (Die Geometrie in ihrer Abhängigkeit von den Massverhältnissen des Raumes) in 1881. Boltzmann and Albert Ettingshausen advised Thomas Romich's (Tomaž Romih, * December 8, 1853 Maria Dobje by Planina between Sevnica and Šentjur southeast of Celje-1935 Novo mesto) and Ignac Fajdiga's (1850 Šentvid by Stična-1929 Kranj) Experimental Untersuchung über die Fernwirkung dielektrischer Körper and then

³²⁵⁴ Nahrwold, 1888, 107–121; Höflechner, 1994, 1: 238.

Romich and Nowak's Experimental investigation of dielectric bodies regarding their dielectric aftereffects and Experimental investigation of the long-range effect of dielectric bodies (Experimental untersuchung dielektrischer Körper in Bezug auf ihre dielektrische Nachwirkung and Experimental untersuchung über die Fernwirkung dielektrischer Körper) in 1874. After his rigorous exam Romih finally defended his additional PhD at Graz philosophical faculty in 1889 just before Boltzmann left for Munich. Next year in 1890 in Prague Romih published the first Slovenian inventory of physical appliances, with images, prices and instructions on how to use them as designed by the factory of physical instruments and metrical models of E. Mach Prague students in 1867/68-1871 Dr. František Houdek (1847–1917) and Josef Hervert (1846–1883). Romih became a headmaster of Krško municipal boys' school in 1900. Fajdiga taught physics and mathematics in grammar schools in Graz, Trieste, Novo Mesto, Ljubljana and Kranj and published about plasmatic atmospheric electricity and lighting rods by studies of J. Elster, H. Geitel and E. Mach in Novo mesto in 1896. Boltzmann's work in Graz was continued by the first important Slovenian explorer of oscillating discharges and plasma was Hugo Victor Carl Sirk, born on 11 March 1881 in Graz. He studied physics at Pfaundler's class in Graz because Czermak was an associate professor of experimental physics at the University of Graz only until 30 March 1898. He left before the beginning of Sirk's studies. The theoretical physics was taught by Wassmuth, who, after a twice unsuccessful candidacy, finally moved to Graz from Prague in 1893. He brought from Prague Puluj and Gintel's interest in cathode rays. Wassmuth was also assisted by Streinz, who was at the same time a professor at the Technical College in Graz from 1892. At the Department of Theoretical Physics of the University of Graz the assistant professor was Hausmaninger and associate professor was S. Šubic, who was retired in the middle of Sirk's studies in September 1902.

Sirk researched molecular size of soluble starch (Über die Molekulargröße löslicher Stärke) for his doctorate advised by the chemists Hugo Schrötter in 1904 and worked in the following years at the Graz Physical Institute. It was well equipped for investigation of discharges in gases, since soon after Roentgen's detection, Roentgen photographs

were taken both by Pfaundler and Czermak in Graz labs.³²⁵⁵

As early as 21 January 1896, at the session of the Viennese Academy, Pfaundler had published his own X-ray photo of a needle in the palm of his hand for the needs of surgery with illumination of 15-20 minutes, eight days after Boltzmann's report.³²⁵⁶

Simultaneously with his research work, Sirk taught at the Viennese university, so that he was prepared for his lecturing in Ljubljana. Even before the establishment of the University of Ljubljana in 1919, at the initiative of the engineer Milan Šuklje, Sirk began his lectures at the temporary higher education course for students who intended to study the technique. Lectures lasted from March to November 1919 with two semesters of study of techniques. Rihard Zupančič taught mathematics to the students there.

Rubinowicz became the first full professor of theoretical physics at the Faculty of Arts of the University of Ljubljana on July 24, 1920, but on 23 February 1922 he left for Technical University of Lvov.

Kušar from Reteče near Škofja Loka lectured on the Theoretical Physics at the Faculty of Philosophy. At the lower gymnasium in Kranj and at higher gymnasium in Ljubljana he received Jožef Anton Schiffrer von Schiferstein's (Šifrer, 1677 Kranj-1756) scholarship for talented students. During his studies at the Viennese Faculty of Philosophy, he received much higher Knafelj's scholarship from 1892/93. Just after Kušar's matriculation, J. Stefan died, and Boltzmann taught physics. In 1896, Kušar finished his studies of mathematics and physics and received his doctorate in 1897 with a dissertation in the field of mathematics: "Third and fourth level congruences". As Sirk, Kušar also did not work out any physics for his PhD, which was a great handicap for their later chairs of physics in Ljubljana. In 1898, he completed his graduation teaching exam, whereby he was able to teach mathematics and physics at secondary schools. He taught in Kranj, Koper and Ljubljana. He was in professional training in Berlin in 1903 and in Paris in 1902, 1928, and 1937. In 1919, he briefly helped

³²⁵⁵ Šubic, 1896, 187.

³²⁵⁶ Glasser, 1959, 186.

to organize the education at the Ministry of the Arts and the Worship in Belgrade.

From December 1919, at the Technical Faculty, he conducted an experimental physics course as a "part-time teacher", took care of the Physical Institute, equipped a laboratory and led a library. On September 1, 1924, Kušar became an associate professor of experimental physics at the Faculty of Engineering. A complimentary expert opinion was written for him by the mathematician and the second rector of the University of Ljubljana, prof. Zupančič. Due to eye problems, Kušar was on sick leave several times and was retired on 31 October 1932. Lectures from experimental physics were in the rooms of real gymnasium until the spring of 1925, when the faculty of engineering received a high ground floor in the east wing of the main university building for its physical and mathematical institute. It worked there for another twenty year.

Due to Kušar's illness, Nardin from the technical high school delivered a part-time lecture on the physics for the Faculty of Engineering in 1927. Between April 1928 and 1934, he was replaced by the Viennese private assistant Sirk who became a contractual full-time professor of experimental physics at the Faculty of Engineering. The professors Plemelj and Zupančič were against his election, but they were voted out. Despite of Slovenian origin, Sirk only partly mastered Slovene language, and he was accused of being a German, in fact a Jew by all his mother's wholesale industrialist ancestors from Bohemia, Budapest and Vienna. Hugo Sirk's grandfather Mathia was born at the neighbourhood of Trebnje just like the famous Boltzmann's student I. Klemenčič. In 1860s Mathia worked as the chief guard in Šoštanj, the native city of his wife, just like the grandfather of Tobias Gruber did in Vienna. After his retirement Mathia's family moved to Radetsky Strasse 2 by Jakominiplatz in Graz near the new Joanneum Regional and Technical College established in 1864 with a diploma examination and specialist training needed for his son. Hugo Sirk's Slovenian father Victor H. Sirk (* 1845) used to be technical officer machinist of 3rd class promoted on 1st November 1870, of 2nd class between 1st November 1874 and 1878 at the Habsburgian Navy, as well as a teacher of mechanics and mechanical engineering at the machine school (Maschinenschulen zu Pola,

Strojnička učiona, Scuola di macchine) in Pula with one year course for engineering sub-officers and three grade course for 14-16 years old freshman. At marine corps in Pula he collaborated with the inventor's father Karl baron Codelli who served as first lieutenant at battleships of the line in from 1st May 1869 until his death in 1878 and with Noordung's father Dr. Jožef Potočnik who became frigate physician on 1st November 1869 and served as physician at (Codelli's?) ship of the line in 1878-1879 and as marine staff physician in 1893-1894. The inventor Anton Codelli served as a line ship sea aspirant from 1st October 1894 and as sea cadette from 1 March 1896 to 1897. Therefore, the military marine corps in Pula used to be the cradle of Slovenian technicians.

In 1875 Victor H. Sirk published a monography on marine engines steam boilers and marine steam navigation and researched in London n July 17, 1878. After his marriage with a wealthy Jewess he left Pula and settled in Grazer Jacomini Gasse (later downtown square and district) near his parents as engineer and inspector of steam boilers. On July 2, 1890 in Ljubljana in order to develop a reliable and trained machine and boiler attendants he held a specialist course to which a total of 34 participants had registered, as did in previous years. Therefore, Hugo Sirk knew Ljubljana well even before he got his chair there, but his Slovenian grandfather Mathia died before Hugo was dozen years old which deprived Hugo of opportunities to learn Slovenian language better in rapidly Germanized downtown Graz. On July 29, 1915, few months after he received his habilitation (venia legendi) in Vienna in 1914. Hugo Sirk resigned from the Catholic Church in Rossau in Vienna, which might be another reason for Plemelj's anger even if Zupančič did the same to enable his orthodox remarriage. Hugo Sirk taught Peterlin and his year older classmate Miroslav Adlešič. Adlešič and Josip Potokar graduated in physics in Ljubljana in 1930 as the only students before the Second World War.

Peterlin, Anton Moljk, Ivan Kuščer who had the Viennese Jewish mother like Sirk, and others graduated from mathematics. In 1930, Peterlin and Kuhelj became assistants at the Technical Faculty, where Peterlin lectured experimental physics since 1933. Peterlin became Sirk's assistant and retained the post after Sirk's appointment as assistant professor at the University of Vienna in 1934. The

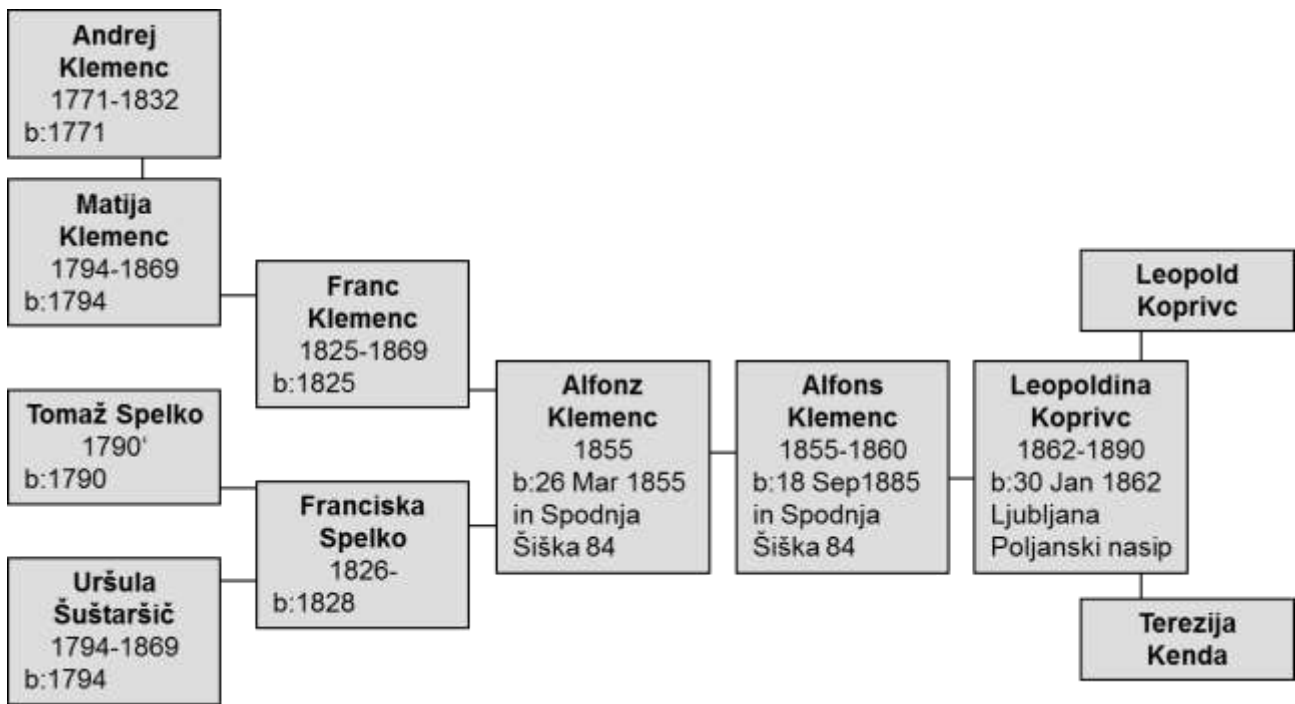

Figure 29-16: Family of Alfons Klemenc

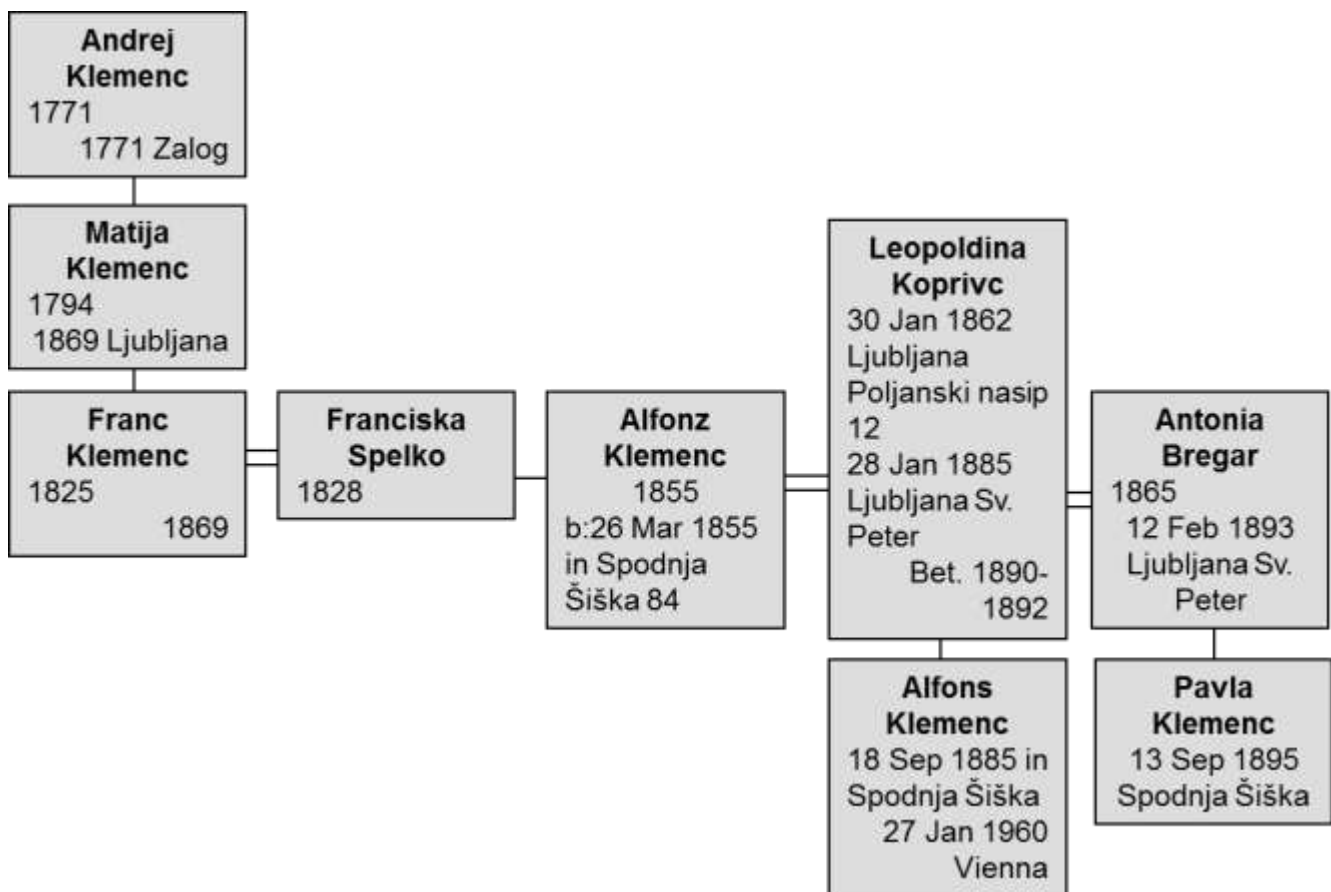

Figure 29-17: Klemenc's family

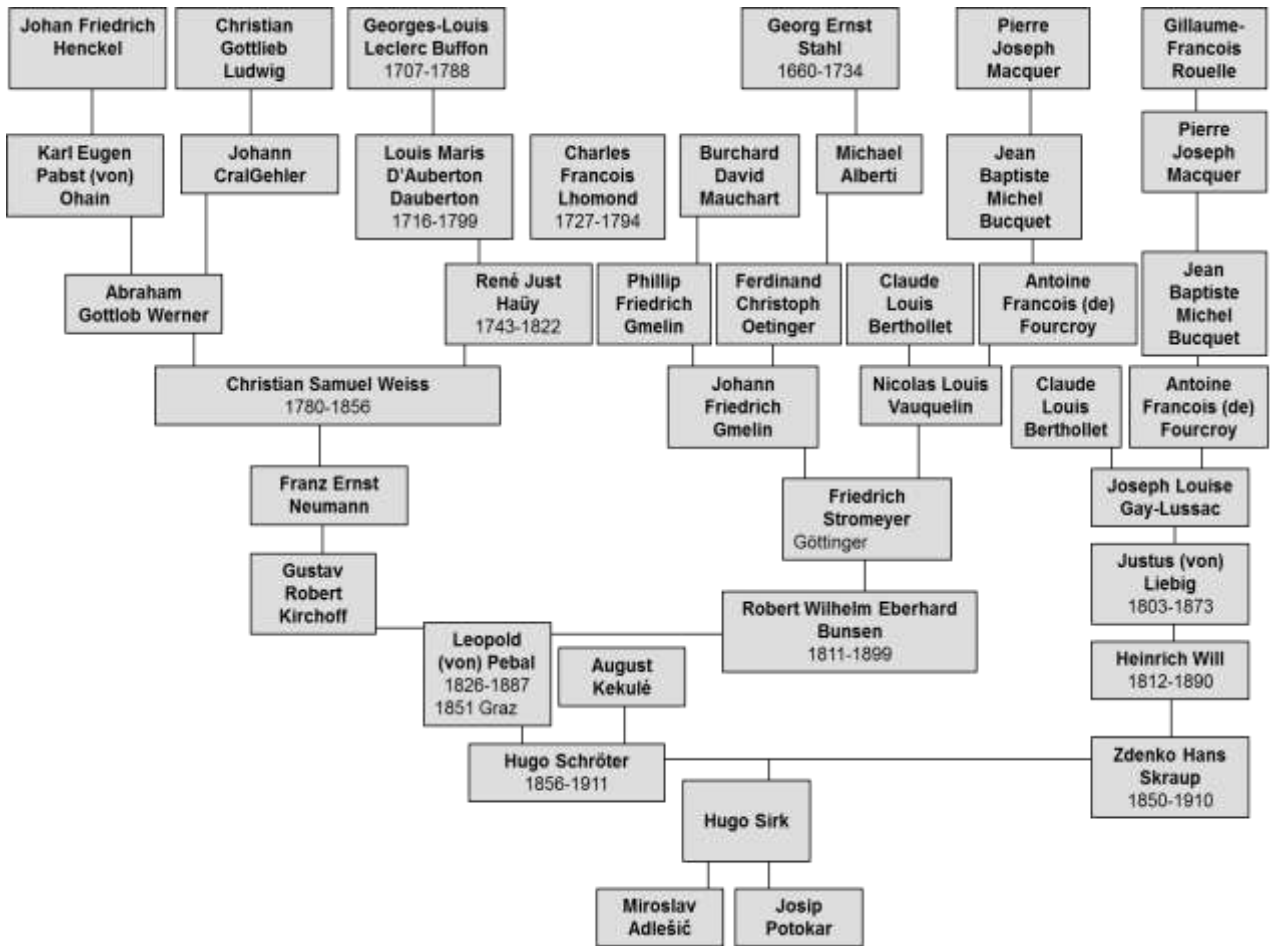

Figure 29-18: Academic ancestors of Hugo Sirk including Buffon, Stahl and Bunsen

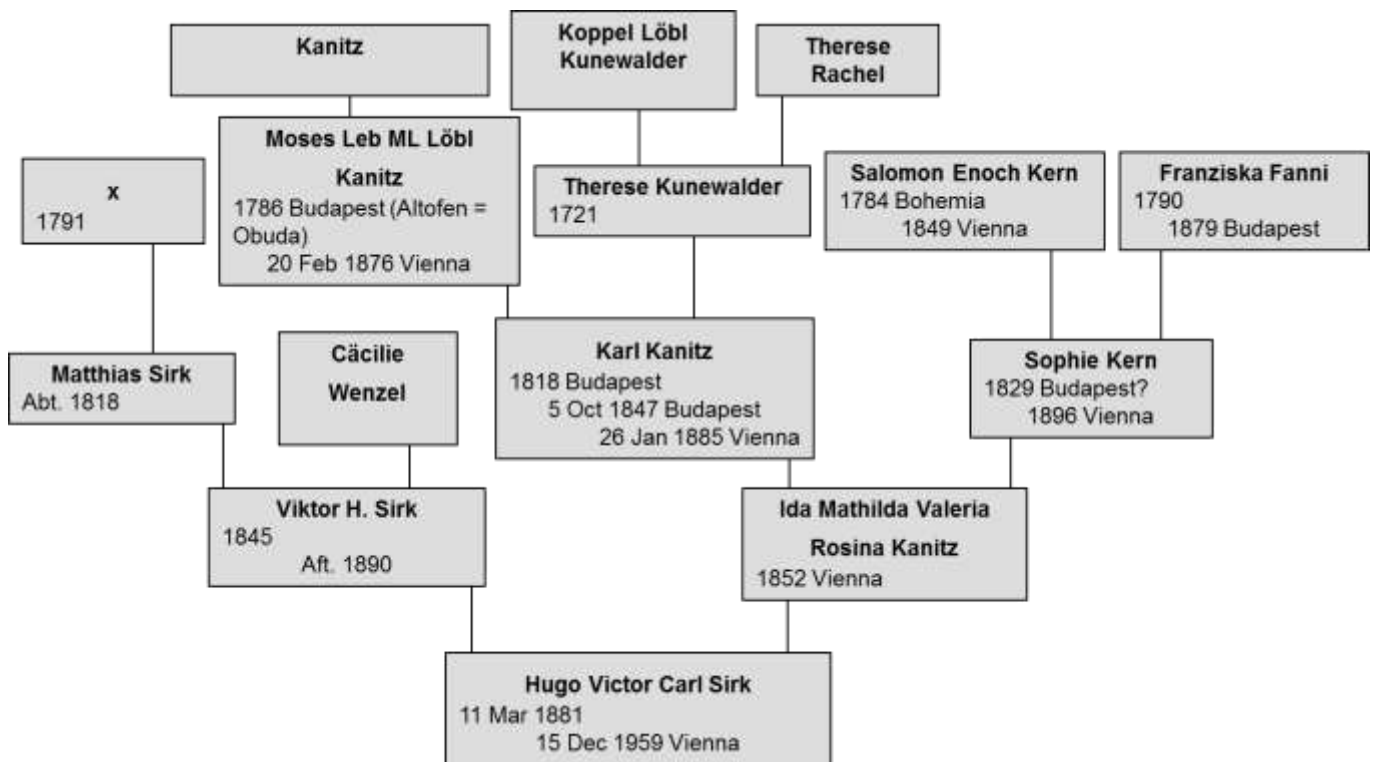

Figure 29-19: Geneological ancestors of Sirk

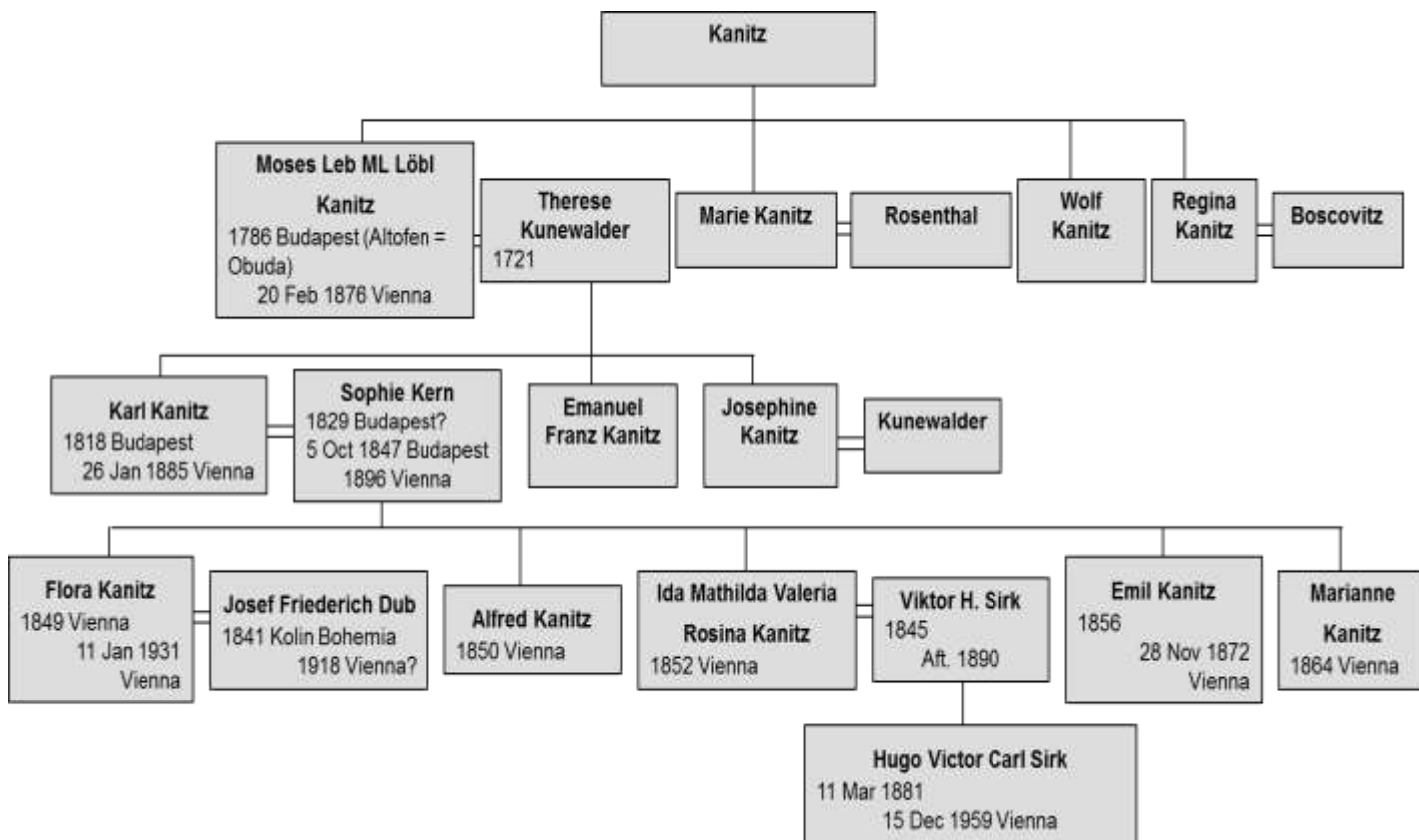

Figure 29-20: Geneological ancestors of Sirk by Jarni line

students attended lectures on physics at the Faculty of Engineering at Kuhelj's class.

In 1930 and 1931, the authorities in Ljubljana tried in vain to employ a full professor of theoretical physics at the Faculty of Arts in Ljubljana. They wished to persuade the son of Andrija the Croat Stjepan Mohorovičić (1890-1980) to take over the post which was somewhat risky as Stjepan Mohorovičić disliked Einstein just as Kušar did before him. Stjepan Mohorovičić also had political troubles and therefore never left high school teachings although he predicted positronium in *Astronomische Nachrichten* in 1934. His prediction was experimentally verified in 1951.

In 1938, Kuhelj was elected as an associate professor and for some time he replaced Peterlin's Physics lessons. After returning from study leave in Germany, Peterlin was elected as assistant professor in 1939, and in the same year he moved from the Faculty of Technical Sciences to the Faculty of Philosophy. In 1939, he was appointed as the honorary lecturer in experimental physics at the Faculty of Philosophy.

Dr Rihard Klemen was an assistant professor for agricultural chemistry and chemistry of ferments at the Faculty of Engineering. In the following year 1940, Moljk became an assistant at the Physics Institute, while Peterlin was a lecturer in physics at the Faculty of Engineering. The head of the Physical Institute was often the mathematician Zupančič until he left for Austria in 1945.³²⁵⁷

At the Faculty of Medicine, J. Reisner gave a lecture in physics in 1920/21. The following year, he was replaced by Nardin, who taught at the Faculty of Medicine as a full professor and founded the Physical Institute.

Sirk was promoted to the rank of the associate professor in Nazis' Vienna in 1940 despite of being a Jew as the Jewish descent is granted by female lines. His mother's wealthy Kantz family of Budapest-Viennese bankers and wholesale sellers of sewing needles (Diamond-eyed, drill-eyed) probably helped him. The following year he published a textbook for natural science studies of mathematicians with numerous examples related to

³²⁵⁷ Suhadolc, 2000, 148, 183.

Van der Waals', Maxwell's, and other equations of physics. In the cover of his textbook Sirk specifically pointed out his former Ljubljana chair.³²⁵⁸ He was not in any deep dispute with the fascist regime, which forced Schrödinger to leave the University of Graz in 1938. Sirk published first-class research at his late age³²⁵⁹ and became very active translator in Esperanto language. Sirk wrote many scientific articles in the Esperanto language and translated a lot from German language to Esperanto language including the work of the Austrian socialist party member Viennese professor of physics Hans Thirring (1888-1976). Thirring was the head of the Institute of Theoretical Physics in Vienna. The socialist and pacifist Thirring lost his job after Anschluss in 1938, and after the war he became the Dean of the Faculty of Philosophy in Vienna and the socialist member of federal council. Thirring corresponded with Einstein in 1917, and he was a friend of Sigmund Freud. Sirk also wrote about Humanism of the Jewish initiator of Esperanto Ludwik Lejzer Zamenhof (Ludwik Łazarz Zamenhof, 1859-1917) and about the history of Esperanto language. After the reorganization of the International Congress Summer University Groet of North Holland in 1948 he regularly conducted his physical themes at the conferences until his death. He was retired in 1952 and died in Vienna on December 15, 1959.



Figure 29-21 A vacuum joke of the author Urška Južnič

³²⁵⁸ Sirk, 1941.

³²⁵⁹ Sirk, 1934, 129-142; Sirk, 1959, 60-62.

30 Industrial Uses of Vacuum Technologies: IJS & IEVT & Haldane

30.1 Peterlin's Contribution to the Development of Vacuum Techniques

30.1.1 Introduction

Many Peterlin's Ph.D. candidates advanced Slovenian vacuum technology. The merits of all Peterlin graduates are even greater. What kind of Sirk's and Rubinowicz's teachings enabled Peterlin's success even if he was basically a theoretical physicist? The Ljubljana authorities were unable to keep Sirk and Rubinowicz for long similarly as they were not able to keep Frischlin three and a half centuries earlier. The natives Plemelj, R. Zupančič, J. Plečnik, Milan Vidmar and Samec established their faculties while physics lacked such Slovenian heroes also because of J. Stefan's premature death.

30.1.2 Samec's Spectral Analysis

Peterlin's relatives and his ancestors were important Slovene physicists, mathematicians and chemists. His wife's grandfather Maks Samec became a doctor in Kamnik after studying in Graz. Samec's discussions show a wide range of his insights into current professional literature. In Samec's discussion of spectral analysis, we find even many interesting physics thoughts that he learned at the University of Graz at Ernst Mach and S. Šubic's lectures.

In the introduction to Spectral Analysis, Samec first described some history of optics. He linked Newton's optical experiments from the years 1676-1704 with modern conceptions. Samec did not even mention that at the beginning of the 19th century Newton's corpuscular theory was replaced by the wave theory of light. With this simplification, Samec described the continuous development of optics leading to the discovery and the use of spectral analysis in the most recent times. Samec's summary of the results of the

spectral analysis in the Slovene language was published only a decade after its beginnings in Germany, when Kirchhoff and Bunsen enabled a real breakthrough in chemistry by the discovery of caesium and rubidium as the new elements between 1859-1860. The third element (thallium) was added by eastern French expert Claude Auguste Lamy and the famous London vacuum technology innovator Crookes in 1861.

Samec was interested in John Tyndall's vacuum experiments: "Tyndall proved that so heavily rarefied matter could reflect the sunlight. He put in an airless glass tube 1/100 gran (0.0082 grams), of a practically unobservable allyl iodide steam, and in the dark before the tube he provided the electric sparks. The entire tube looked like filled with a dense, blue-reddish fog. In the light, however, the tube looked like completely empty."³²⁶⁰

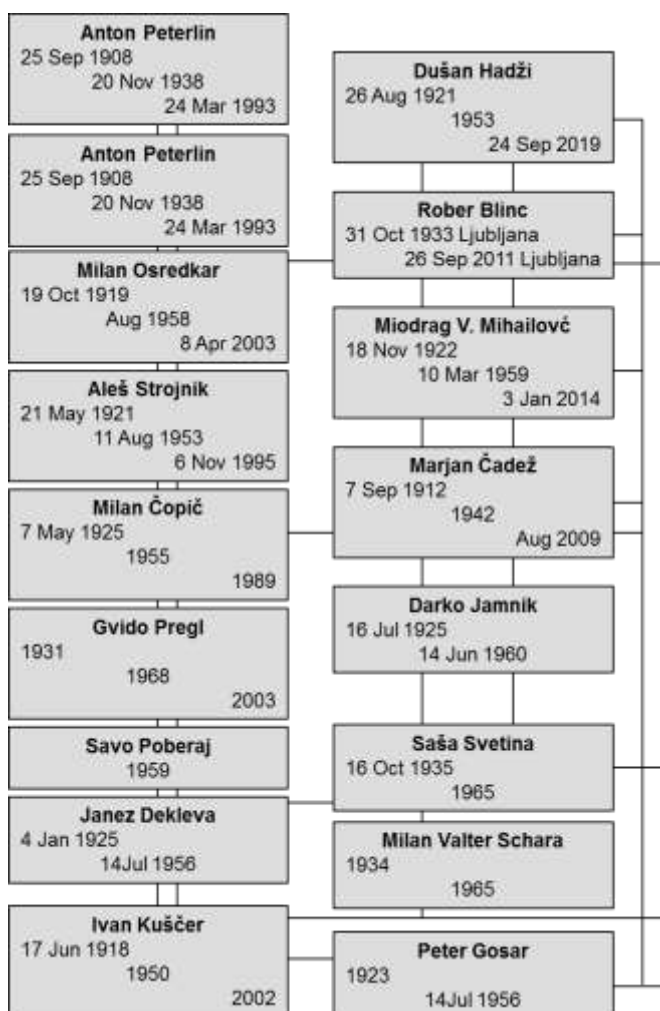

Figure 30-1: Students of Peterlin with years of their promotions in the centre

³²⁶⁰ Samec, 1871, 281.

Table 30-1: Four generations of Peterlin's Doctoral students

Anton Peterlin graduated with diploma in mathematics 1930 (supervised by Plemelj); PhD.in Sep. 1938 (supervised by Stuart, Berlin)	Ivan Kuščer (Graduated with diploma in mathematics) 1950/ 1. 7. 1950/5. 4. 1952 ³²⁶¹	Peter Gosar 1955/ 17. 12. 1955/28. 9. 1956 ³²⁶²	Igor Vilfan 1975		
			Peter Prelovšek 1975	Anton Ramšak 1990	Tomaž Rejec 2003
				Janez Jaklič 1996	
				Aleš Zupan 1996	
				Dean Cvetko 1996	
				Darko Veberič 2001	
			Tomaž Kranjc 1985		
		Darko Jamnik 1959/28.3./14.6.1960 ³²⁶³	Uroš Miklavžič 1965/28.12.1965/14. 1. 1966 ³²⁶⁴		
			Gabrijel Kernel 1965/28. 12. 1965/14. 1. 1966 ³²⁶⁵	Aleš Stanovnik 1980	Marko Starič 1992
					Dejan Žontar 1998
					Robert Jeraj 1999
				Franci Sever 1984	
				Peter Križan 1987	Damijan Škrk 1999
					Rok Pestotnik 2001
					Andrej Gorišek 2003
				Mark Pleško 1987	
				Danilo Zavrtanik 1988	Andrej Filipčič 1995
					Boštjan Golob 1996
					Igor Mandić 1997
					Samo Stanič 1999
					Borut Eržen 1999
				Marko Mikuž	Matevž Tadel

³²⁶¹ Kokole, 1969, 57.³²⁶² Kokole, 1969, 57.³²⁶³ Kokole, 1969, 57. After Peterlin's departure, Kuščer took over Peterlin's supervising.³²⁶⁴ Kokole, 1969, 60³²⁶⁵ Kokole, 1969, 60.

				1988	2001
				Bojan Boštjančič 1990	
				Ervin Križnič 1993	
				Tomi Živko 1994	
				Tomaž Podobnik 1995	
				Gordana Medin 1997	
				Borut P. Kerševan 2000	
				Marko Bračko 2001	
			Raša Pirc graduated with diploma in 1963 (PhD in 1968)		
			Dušan Brajnik 1974		
			Matjaž Korun 1981		
		Rudolf Kladnik 1962/23. 3. /12. 6. 1963 ³²⁶⁶			
		Sergej Pahor (graduated with diploma in 1958 Moljk) 1963/4. 6. 1963/9.6.1964 ³²⁶⁷	Tomaž Kalin 1978		
		Janez Ferbar 1986			
	Milan Čopič 1955/5.2.1955/10.3.1955 ³²⁶⁸	Gvido Pregl 1968	Matjaž Ravnik at Maribor Technician Faculty ³²⁶⁹ 1988	Matjaž Božič 2004	
				Žagar Tomaž. Activation of components of body in research reactor TRIGA 2002	
				Luka Snoj 2009	
			Acquah, I. N. 1980		
			Rant, Jože. Research of possibility of uses of radiographic methods for analysis of surfaces 1986 co-supervisor Polde Leskovar		
			Remec, Igor. Influence of arrangements of fuel on neutron exposition of pressured vessel of nuclear reactor: Dissertation. Maribor 1991		
			Samo Korpar 1997		
			Marko Mavčec 1999		
			Mateja Peršič 1999 (co-supervisor Ravnik)		
	Črt Zupančič 1955/27. 3.	Bogdan Povh 1960/22 December	Peter Kump 1971		

³²⁶⁶ Kokole, 1969, 60.

³²⁶⁷ Kokole, 1969, 58.

³²⁶⁸ Kokole, 1969, 57.

³²⁶⁹ Co-supervised by Milan Čopič, who also supervised Ravnik's graduate and master thesis, but Čopič was not habilitated as supervisor of PhD candidates at that time.

	1956/10. 3. 1959 ³²⁷⁰	1960/28 February 1961. ³²⁷¹			
	Janez Dekleva 1955/29.3./14.7 .1956 ³²⁷²				
	Stanislav Toš graduated with diploma in 1950 (Pedagogical curricula)				
	Anton Moljk 1956/21.3./20. 4. 1957 ³²⁷³	Jože Pahor 1961/14. 10./22.11./1961 ³²⁷⁴			
		Alojz Kodre 1973	Iztok Arčon 1992		
			Jana Padežnik Gomilšek 1998		
			Rok Prešeren 2000		
			Matej Komelj 2000		
		Danica Burg Hanžel 1973			
		Ferdinand Grešovnik 1973			
		Marjan Hribar 1974	Artur Mulheisen 1996		
			Matjaž Štuhec 1996		
	Miodrag V. Mihailović 1958/16.2.1959 /10.3.1959 ³²⁷⁵	Mitja Rosina 1964/29. 12. 1964/26. 2. 1965 ³²⁷⁶	Mohamed Zaky Fahmy 1982		
			Bojan Golli 1983		
			Anton Vrbovšek 1994		
			Borut Bajc 1994		
			Damijan Janc 2004		
		Mitja Kregar 1965/12. 7. 1965 /28.9.1965	Miloš Budnar 1983	Matjaž Kavčič 2000	
				Alenka Razpet 2002	
				Matjaž Kobal 2003	
			Žiga Šmit 1985	Darja Abramič 1995	
				Primož Pelicon 1997	
			Vladimir Cindro 1988	Gregor Kramberger 2001	
			Matjaž Žitnik (report of Mitja Rosina in October 2007)	Klemen Bučar 2004	
				Mihelič Andrej 2006 ³²⁷⁷	
		Mitja Najžer 1965/28. 12. 1965 /14. 1. 1966 ³²⁷⁸			

³²⁷⁰ Kokole, 1969, 61. Povh had many doctoral candidates abroad as narrated by Mitja Rosina in October 2007.

³²⁷¹ Kokole, 1969, 61. Had many doctoral candidates abroad as narrated by Mitja Rosina in October 2007

³²⁷² Kokole, 1969, 112

³²⁷³ Kokole, 1969, 60.

³²⁷⁴ Kokole, 1969, 61

³²⁷⁵ Kokole, 1969, 57.

³²⁷⁶ Kokole, 1969, 60, 61.

³²⁷⁷ report of Mitja Rosina In October 2007

³²⁷⁸ Kokole, 1969, 60. Najžer was in laboratory for radiography (Ilić, 2000, 251).

		Franc Cvelbar 1965/12. 3. 1966 /15. 9. 1967 ³²⁷⁹	Andrej Likar 1976	Ivo Verovnik 1999	
				Saleh Ashrafi 2001	
				Tim Vidmar 2002	
				Gregor Omahen 2003	
			Rafael Martinčič 1980		
			Aleš Rokavec 1994		
			Tomaž Gyegyek 1996		
			Mladen Stojanović 1997		
		Alenka Hudoklin Božič 1968			
		Desan Justin 1971			
		Norma Mankoč Borštnik 1974	Metod Škarja 1999		
		Matjaž Poljšak 1982			
		Rajmund Krivec 1986			
	Milan Osredkar 1958/4. 8. 1958/27. 6. 1959 ³²⁸⁰				
	Savo Poberaj 1958/24.2.1959 /10.3.1959 ³²⁸¹	Ahmed Turkey 1981			
		Milan Čerček 1983			
	Robert Blinc 1958/24. 2./10. 3. 1959 ³²⁸²	Ivan Zupančič 1964/20.5. 1965 /22. 6. 1965 ³²⁸³	Janez Pirš 1975		
		Saša Svetina 1965/7. 9.1965/28. 9. 1965 ³²⁸⁴	Milan Brumen 1985	Marko Marhl 1998 co-supervisor Mathematician Joso Vukman	
			Aleš Igljč 1995		
			Bojan Božič 1999		
			Jure Derganc 2003		
		Milan Schara 1965/20. 12. 1965/ 7. 1. 1966 ³²⁸⁵	Franci Demšar 1987		
			Janez Štrancar 2000		
		Edo Pirkmajer 1965/29. 12. 1965/7. 1. 1966 ³²⁸⁶			
		Milan Pintar 1965/25. 4. 1966 /15. 9. 1967 ³²⁸⁷			

³²⁷⁹ Kokole, 1969, 59

³²⁸⁰ Kokole, 1969, 61.

³²⁸¹ Kokole, 1969, 113.

³²⁸² Kokole (1969, 56) noted Blinc's supervisor Hadži, which he was only on operational level, while on the official Faculty level Peterlin was noted as a mentor (Information of Tanja Peterlin-Neumaier 12 January 2007). According to data of FNT and on Cobiss platform, it was supposedly a typescript dissertation typed in the year 1958. As a supervisor Peterlin was noted, but in the time of promotion he was already abroad. In the time Blinc's and Poberaj's defence (24 February 1959) Peterlin was back in Ljubljana for a while. He left Ljubljana just before Blinc's promotion. Poberaj's had his promotion on International Women's Day 8 March 1959. Later Peterlin was again in Ljubljana from early August until the middle October 1959, so he could attend the defence of a dissertation of Bibijana Dobovišek Čujec on 24 September 1959.

³²⁸³ Kokole, 1969, 59.

³²⁸⁴ Kokole, 1969, 59.

³²⁸⁵ Kokole, 1969, 66. Next year together with Blinc, Poberaj and Stepišnik published research of electron spin resonance.

³²⁸⁶ Kokole, 1969, 62.

	Janez Stepišnik 1971	Mohamed Roushdy Sabry 1980	
		Miha Kos 1992	
		Gorazd Planinšič 1993	
		Andrej Duh 1999	
		Aleš Mohorič 2000	
	Zvonko Trontelj 1971	Janez Pirnat 1985	
		Vojko Jazbinšek 1994	
		Zvonko Jagličič 1996	
		Boštjan Jug 2001	
		Andrej Jeromen 2004	
	Boštjan Žekš 1972	Igor Sega 1979	
		Rudi Podgornik 1986	Jure Dobnikar 2000
			Matej Praprotnik 2003
		Veronika King Iglič 1993	
		Brigita Kutnjak	
		Urbanc 1993	
		Mojca Čepič 1993	
		Barbara Rovšek 1999	
		Daša Grabec 2002	
		Primož Peterlin 2002	
	Miha Mali 1972		
	Borut B. Lavrenčič 1973		
	Slobodan Žumer 1973	Samo Kralj 1991	
		Milan Ambrožič 1996	
		Primož Zihrel 1997	
		Jure Bajc 1998	
		Mitja Slavinec 1999	
		Anamarija Borštnik 2000	
		Andreja Šarlah 2001	
		Gregor Skačej 2002	
		Daniel Svenšek 2003	
		Matej Bažec 2005	
		Zlatko Bradač 2005	
	Janez Seliger 1973	France Sevšek 1988	
		Orest Jarh 1989	
		Darko Hanžel 1992	
		Igor Serša 1996	
		Gregor Mali 2001	
	Pavel Cevc 1975		
	Radko Osredkar 1975		
	Marjeta Šentjura 1975	Tilen Koklič 2004	
	Matija-Iko Burgar 1978		
	Marija Jamšek Vilfan 1978		
	Martin Čopič 1979	Marko Zgonik 1987	Mojca Jazbinšek 2001
		Boris Majaron 1993	
		Igor Poberaj 1993 (co- supervisor Dragan Mihailović)	
		Tomaž Mertelj 1996 (co- supervisor Dragan	

			Mihailović)		
			Abbas Rastegar 1996		
			Irena Drevenšek Olenik 1996	Lea Spindler 2002	
			Marta Klanjšek Gunde 1996		
			Nataša Vavpotič 1998		
			Alenka Mertelj 1998		
			Marko Marinček 1999		
			Gorazd Poberaj 2000		
			Mojca Vilfan 2001		
			Rok Petkovšek 2003		
		Venčeslav Rutar 1980			
		Janez Slak 1980			
		Ludvig Čanžek 1981			
		Lenart Barbič 1981			
		Metka Luzar Vlachy 1982			
		Majaž Lukač 1986			
		Janez Dolinšek 1987	Peter Jeglič 2004		
			Matjaž Panjan 2010		
		Bogdan Topič 1987			
		Igor Muševič 1993	Klemen Kočevar 2001		
			Nina Jug 2002		
			Marjetka Conradi 2003		
		Boštjan Zalar 1994			
		Aleksander Zidanšek 1995			
		Helena Janžekovič 1995			
		Tomaž Apih 1997			
		Miha Škarabot 1997			
		Denis Arčon 1997			
		Nataša Urbančič Kopač 1997			
		Mojca Urška Mikac 1999			
		Vid Bobnar 2000			
		Alan Gregorovič 2002			
	Marjan Ribarič 1959/18 Sep./24 November 1959 ³²⁸⁸	Luka Šušteršič 1989			
	Bibijana Dobovišek Čujec 1959/24. 9./24. 11. 1959 ³²⁸⁹				

3288 Kokole, 1969, 58.

³²⁸⁹ Bibijana Dobovišek Čujec graduated in 1950. Peterlin did not bring his supervising of Bibijana Dobovišek Čujec's PhD to its successful end according to report of his daughter Tanja Peterlin-Neumaier and Strnad (2006). But Kokole (1969, 60) did not note any limitations of Peterlin's supervising. Bibijana Dobovišek Čujec supervised many PhD candidates abroad as narrated by Mitja Rosina in October 2007.

Samec used a somewhat dubious mechanical description of the ether, which in physics of those days covered many of the features of today's vacuum: "The thinner the ether is, the more of its oscillations are needed to excite the (human) retina."

Samec also noted an interesting similarity between ether and air, as well as between the eye and the ear. Descriptions of the ether like Samec were not unusual in the Habsburg Monarchy at that time, although individual criticism of ether at the writings of Graz professor Simon Šubic (1862) and his friend, the teacher of Nikola Tesla Martin Sekulić also gained some attention. Samec's note appeared in 1874:³²⁹⁰ "Physicists of the recent times claim that there is no ether, but that what has been called ether is just plain gas (air) that fills up, certainly very rarefied, all the world's spaces."



Figure 30-2: Samec's vacuum tubes with hydrogen, solitre and carbon dioxide (Samec, 1871, 267)

Of course, Samec was also aware of the significance of the vacuum in experiments:³²⁹¹ "... If, then, we observe spark through the spectroscope, we do not see only the spectra of metal, but also the spectrum of each individual component of the air; we see, for example, the spectrum of hydrogen, oxygen, nitrogen. If, however, we want to get a pure spectrum, this is the spectrum of the metal itself only, we must make this experiment in the vacuum space."

Samec's discussion also included quotes of very modern papers, such as the publications which

³²⁹⁰ Samec, 1871, 259.

³²⁹¹ Samec, 1871, 268.

appeared in 1868 under the pens of Ångström or Zöllner. According to the short delay of Samec's writing about the German language publications of researchers, he certainly read German professional literature, most probably Poggendorff's *Annalen der Physik und Chemie*.

In 1876, Samec published on brain with some Darwinist echoes.³²⁹² He translated the *Somatology* of Jan Nepomuk Woldrich (1834-1906 Prague), but his publisher Slovenska Matica doubted about the successful print and sales because of Samec's lack of knowledge of pedagogical conditions as he never lectured in schools. Thus, the translation was completed by the Gorizian professor Fran Erjavec, who published it under his name.³²⁹³ Samec often used Russian literature in his writings, especially in Črtica (Note) on the impact of the climate in 1871. Samec even translated Turgenev's novel *Dim* (Smoke) in Slovene language.³²⁹⁴

Samec had advanced views: he opposed the use of corsets in the women's wardrobe, and in his garden, he set up a gym for his children. He visited the 3rd International Electrical Exhibition in Vienna, which was led by Jožef Stefan on the technical and scientific basis from 11 August 1883 onwards.³²⁹⁵ In Kamniška Bistrica he was the mayor (1880-1886) and since 1883 a regional representative of the districts of Radovljica, Tržič and Kamnik. He wanted to build a dam and a power plant for the needs of Kamnik; unfortunately, the project was abandoned because of his premature death. His son, the chemist Maks, later became the honorable citizen of Kamnik. Both are buried in Kamnik.

30.1.3 Samec Junior in Chemistry

The son of Maks Samec, Maks Samec the younger (* June 27, 1881; † June 1, 1964), studied chemistry in Vienna at a time when he could still hear the lectures of the famous Boltzmann. Already as a twenty-year-old he published a fifty-pages long discussion on meteorology and air transparency in various weather conditions for the Viennese Academy in 1905. In the end he thanked the court councilor Hans Pernter for his help. The

³²⁹² Bernik, 1964, 16.

³²⁹³ Bufon, 1964, 370-372.

³²⁹⁴ Smerdu, 1964, 382.

³²⁹⁵ Paper on 50th anniversary of death, *Jutro* (Ljubljana), 20. 8. 1939; Message of Tanja Peterlin-Neumaier 17. 12. 2006.

younger Samec participated in the formation of the Colloid Society in 1922, which awarded him a half a decade later. He published a lot in *Kolloidzeitschrift*, which was printed in Dresden since 1906 with Ostwald as coeditor after 1907.

Maks Samec the younger was a rector of the University of Ljubljana between 1935-1937.³²⁹⁶ On the 16th May 1940, he was elected a regular member of the Academy of Sciences and Arts, and on 6 June 1940 the President announced his election. On 16 December 1940, Samec typed on the sheet of half-A4 format to renounce his membership in the academy, as professor Plemelj's "cooperation was effectively hindered by his presence" at meetings of the mathematical-natural class. On 1 January 1941, the President of SAZU (SASA) accepted the resignation of Samec, and on February 1, 1941, the manager of SAZU (SASA) also did the same. On 6 December 1949, Samec as administrator of the Chemical Institute in Ljubljana was accepted again as a regular member of the Slovenian Academy of Sciences in the mathematical, technical, and physical sciences class.³²⁹⁷

In the summer of 1945 Maks Samec was deprived of his full professorship in Ljubljana for the alleged violation of cultural silence, since he published his findings in German scientific journals during the war. Samec's co-author Peterlin did not suffer from such an absurd measure. Samec's opponent was a professor of inorganic chemistry in Ljubljana. Samec could no longer work in the laboratory, which he himself founded in 1919 in the basement of the real school on Vegova street, but Samec could only work in the emergency laboratories of the building of today's NUK. As a student, Boris Kidrič knew Samec's work in the field of starch and colloids; so, he protected him, so Samec continued to receive a salary despite the loss of his profession. However, Samec was certainly punished just a little bit, because Samec was still able to research in another facility which Kidrič established for his old professor Samec. Much worse happened to Samec's co-worker Salvislav Jenčič (1891-1968),

who was retired without the right to a pension. Salvislav was the brother of the first Samec's wife Maria (Mira) Jenčič, who died shortly after the birth of her daughter. The noble Jenčič family were from Kočevje, later from Nova vas in Dolenjska. Samec second German wife was much sharper and she was expelled from Yugoslavia as a Viennese woman, but Kidrič's order somewhat solved Samec's problems because his wife occasionally maltreated him.³²⁹⁸

On 1 October 1946, Samec became the administrator of the Chemical Institute at SASA in Ljubljana, which originally existed only on paper. On 6 December 2006, for the first time, Samec's prizes for successful chemistry students in Slovenia were awarded.

In 1938, Maks Samec the younger received the Laura R. Leonard Award from *Kolloidgesellschaft*, which was founded in 1922. On 27 September 1938 he received a memorial medal of University of Nancy. He also received August Wilhelm von Hofmann's award of the German Chemical Society on 4 May 1940, the prize of *Arbeitsgemeinschafts-Getreideforschung* (AGF) established at Detmold in 1946, additional doctoral degree from the University of Vienna and several French awards, among them *L'Ordre du Mérite pour la Recherche et l'Invention* (Grand Officier). On 31 December 1949, he received the Federal Planning Commission Prize, and the Prešeren Prize for the year 1950.

Maks Samec, the elder married the daughter of Jožef Rode from Rodice no. 9, where the Cardinal Franc Rode was born later. Theresa Rode and Maks Samec had three children whose descendants became important musicians and scientists. Samec's granddaughter, the mathematician Leopoldina (Oli) Leskovic, married the physicist Peterlin, son of Anton Peterlin from Šiška and Zofija Pučnik from Kranj. Maks Samec the younger was uncle of the wife of Anton Peterlin the physicist. From the end of the 1940s onward, Samec Jr. and Peterlin led the two most important physical and chemical institutes in Ljubljana.

³²⁹⁶ Peterlin-Neumaier, 2004, 46.

³²⁹⁷ *Letopis Akademije znanosti in umetnosti*. 1938-1942 (1943) 1: 296, 298, 308, 332; *Letopis Slovenske Akademije znanosti in umetnosti*, 1948-1949 (1950) 3: 65; Preserved Samec's typescript on a paper of a half A4 format, Library SAZU.

³²⁹⁸ Osredkar, Polenec, 2000, 22.

30.1.4 *Peterlin's Experiments and Lectures on Vacuum Techniques: Slovenian Vacuum Technique at the Time of Peterlin and Supek*

30.1.4.1 Youth and Kinship

Anton Peterlin was the most important modern physicist in Ljubljana. His role would certainly be comparable in many ways to the success of the mathematics of Plemelj if Peterlin could avoid so much trouble in his ascent to power, which Plemelj happily avoided.

The father Anton Peterlin studied under supervision of the professor Jožef Stefan in Vienna, and at the end of his studies of philosophy study he received a prestigious Knafelj's Scholarship with a free flat in Knafelj's Viennese House in 1888/89. He became a Grammar School (gymnasium) professor of physics and mathematics in Kranj, and then at the Poljane Grammar School (gymnasium) in Ljubljana. He processed the arithmetic textbook of Blaž Matek for lower schools according to the new curriculum, while, the Gorizia gymnasium professor Jakob Zupančič reorganized Matek's books for secondary schools in 1910.³²⁹⁹ Blaž Matek (* 5. 2. 1855 Gornji Grad ob Dreti (Upper castle by Dreta River); † 29. 1. 1910 Maribor) published his arithmetic and geometry textbooks for lower Grammar School (gymnasium) between 1896 and 1898, but due to his premature death, he could not completely organize all his works.

Peterlin was born in the family of professor of physics Anton Peterlin of Ljubljana – Šiška and Zofije Pučnik from the important family of tailors in Kranj. Her father occasionally had seven employees. Grandfather on his father's side was a traveling dealer with flour from Gameljne.

The physicist Anton Peterlin the younger had older stepsister Sonja born Guzelj married Remec at Lancovo in Radovljica and he also had a younger sister Marja Peterlin married Lapajne who worked in the accounting office for IJS in Ljubljana. After Anton Peterlin the elder died, his widow Zofia took care of all three children as a primary school teacher. Because her pay was often insufficient,

³²⁹⁹ Vodopivec, 1971, 94; Šlebinger, 1933 SBL, 2: 321; Gspan-Prašelj, Sitar, 1991, 864.

she helped herself with a renting rooms to students, and occasionally even by selling her furniture and jewels.

30.1.4.2 Studies

Anton Peterlin the younger was not satisfied with his gymnasium professors of physics Fran Čadež, therefore Anton Peterlin later criticized Čadež's relatives. So, Anton Peterlin was assisted by a university professor of biology, Pavel Grošelj, who received a philosophical doctorate in 1906 and passed his qualification exam for secondary school teachers with natural sciences as main subject, mathematics and physics as secondary subjects in 1908. In 1910, Grošelj passed his additional exam with physics as the main subject.

Anton Peterlin the younger also used the help of his uncle, dr. Simon Dolar, professor of mathematics, physics and philosophy at the gymnasium in Kranj. Anton Peterlin the younger disliked his high school professor of physics Čadež, but he was greatly assisted by his uncle dr. Simon Dolar who married Zofia's younger sister Mihaela (Hela) Pučnik. Their son Daro Dolar (* 1921; † 2006) became a professor of physical chemistry at the University of Ljubljana; he was the first cousin of Anton Peterlin the younger and participated in public lectures on radioactivity in Ljubljana.³³⁰⁰ In 1957, Daro Dolar earned his doctorate in chemistry in the class of Ljubo Knop, who received his doctorate from the Technical Sciences at Maks Samec's class in 1933.³³⁰¹ In 1965, Daro's colleague Karel Južnič earned a Doctorate in Chemistry. K. Južnič lived in Mirje in Ljubljana with his wife Danica, son Andrej and two daughters; one of them was a physician. However, K. Južnič died relatively young while his skin was severely damaged by radiation as IJS did not have a proper security against radioactivity developed in that times yet.

In 1926, Anton Peterlin first enrolled in the mechanical engineering of the University of Ljubljana, but Rihard Zupančič addressed him before the end of the first semester. Rihard advised

³³⁰⁰ Letter of Marja Lapajne to her brother Anton Peterlin mailed to USA on 30. 5. 1955; letter of the Lady K. Paučnik mailed to Peterlin on 7. 9. 1955, received on 12. 9. 1955 (GDP).

³³⁰¹ Kokole, 1969, 63, 75.

him to enroll in studies of pure mathematics at the Faculty of Philosophy.

Peterlin again did not have much better lecturers at the university, so he liked to listen to Plemelj's mathematical and Vidmar's electrotechnical lectures. Peterlin listened to Vidmar's lectures on electricity, but Peterlin admired very good pedagogy and the educator Zupančič.³³⁰²

Even before the end of mathematical studies, Peterlin became Sirk's assistant lecturer in physics in the fourth year of Peterlin's studies and Peterlin kept that post in 1929-1931. Sirk was not very versed in mathematics, which students felt boldly, because almost all of them had mathematics for their main subject and they judged the math by Plemelj's merits. Sirk lectured mainly on electricity, while Sirk discussed everything else in his course of physics during a few weeks. Peterlin helped him set up an introductory lecture for all students of technique and philosophy.

In his third semester, Peterlin became an assistant for the descriptive geometry of the engineer Milan Fakin and kept his duty for three years in 1927-1929. Milan Fakin took over the lectures of the engineer Ciril Juvan who taught in 1922-1926. Therefore, Fakin taught only for one year before he recruited Peterlin. On 19. 12. 1924 Fakin and his brother Romeo officially changed their family name to Strojnik as the term Fakin have a disrespectful meaning in Slovene slang of Ljubljana.

Julius Nardin was a good experimenter with vacuum devices, while as a lecturer he was not among the best; so, Peterlin attended only one of his lectures. After April 1928, Peterlin listened to Hugo Sirk's lectures, although they were mathematically defective and mainly dedicated to electricity.

On Sirk's recommendation, Peterlin visited for one month Franz Halla (1884 Vienna-1971 Dörfel in Lower Austria) at the Institute of Physical Chemistry of the Viennese Technical College where Peterlin learned X-ray diffraction techniques of measuring scattering X-rays at wide angles and for the first time used top-modern vacuum technology. Prior to the end of his mathematics

studies, Peterlin became Sirk's assistant lecturer in Peterlin's fourth year.

On 16 June 1930 Anton Peterlin graduated in mathematics from the Faculty of Arts in Ljubljana with greatest success under supervision of the professor Plemelj. In the same year, Peterlin and Anton Kuhelj became assistants at the Technical Faculty. In 1930/31, Anton Peterlin taught physics in the eighth grade at the 1st Women's Gymnasium (Lyceum), and in 1931/32 he taught at the Ursuline (Uršulinke) gymnasium of Ljubljana which proved that he must have been a devoted Catholic at least in those times which might provoke some antagonism with Sirk and later with Kuščer.

After graduation, Peterlin measured in Sirk's lab the scattering of X-rays in liquids completely without success, as he could have previously calculated that the effect would be too weak for the measurements. That was one of the reasons why Peterlin had so much doubts in Sirk's mathematical abilities, but that mistake could also be partly Peterlin's fault because Peterlin was not a great expert in experimenting, unlike, for example Peterlin's antagonist Moljk.

Peterlin became Sirk's assistant in 1933. In 1934, Sirk published a paper on X-rays in a magnetic field. Peterlin assisted in Sirk's measurements, for which Sirk thanked him at the end of the article. Peterlin also retained the assistant position after Sirk's appointment as assistant professor of the University of Vienna in 1934/35, after Sirk failed to extend his Ljubljana contract and returned to Vienna. The assistant professor of mechanics Kuhelj took over the lectures on physics at the Faculty of Technology in Ljubljana. In the school year 1935/36 Kuhelj lectured on physics in Ljubljana, while Peterlin began to teach experimental physics in the autumn of 1936. For six or seven years Peterlin was the only lecturer in experimental physics in Ljubljana. As an assistant he organized a physical practicum and conducted student experiments for almost ten years.³³⁰³

From February to May 1936, Peterlin was measuring the scattering of X-ray beams on liquid tetrachloride-carbon in the lab of professor Dragoljub Jovanović (1891–1970) in Belgrade. For eight years Dragoljub K. Jovanović worked at the Marie Curie Institute in Paris, like his student P.

³³⁰² Bartol, 1961, 106.

³³⁰³ Bartol, 1961, 108.

Savić after him, but Dragoljub Jovanović did not love communists so much as Savić and Jovanović became a kind of dissident. Professor Jovanović founded the Institute of Radiology at the Medical Faculty in Beograd in 1927, where he was the head of the institute until 1964. He taught physics to medical students from 1932 to 1966. He also taught physics for the students of veterinary, pharmacy and dentistry. From 1945, Professor Jovanović taught physics at the Department of Physics at the Faculty of Natural Sciences and Mathematics, where he was the Head of the Department and the manager of the physics institute. In addition to all this, the professor Jovanović also had time for his scientific research, and he processed the latest developments in the field of modern physics.

Unfortunately for Peterlin, physics in Belgrade was poorly equipped, but Peterlin at last became domestic in the metropolis of Beograd which proved to be very useful for Peterlin's later politics. The Beograd guys were more oriented towards Parisians just like Polish literati, while the Zagreb guys preferred Germany for their politics and science. Compared to Beograd, in Zagreb they had at least experimental and theoretical physics, but Peterlin did not want to study for his doctorate in Zagreb as Peterlin had much higher international goals. Peterlin wrote a paper about the scatterings of X-rays in liquids and the arrangement of molecules in the liquid, which the Ljubljana German R. Zupančič corrected for him. Peterlin's work was accepted for publication in *Physikalische Zeitschrift* and published in the first months of 1936. This was so exciting that Zupančič wrote to Peterlin that he had send a request for Peterlin's scholarship in Germany for 1937/38, which was again very successful.

On 1 November 1937, Peterlin went to Germany with his scholarship and received a university study leave by the University Council on June 10, 1938 for the period from 1 December 1937 to 1 June 1938 and from 1 November 1938 to 28 February 1939. In 1938 and 1939 Peterlin worked at the Max Planck Institute of Physics at the Berlin Humboldt University and in May 1938 he wrote a dissertation on the hydrodynamic and optical properties of solutions of large molecules.³³⁰⁴ On 22 June he passed the exams. On November 20, 1938, he was promoted to the status of doctor of

natural science with a professor of physics of molecules H.A. Stuart.

Peterlin wished to have a supervisor Peter Debye, who received his Nobel Prize in chemistry for the research of dipole moments two years earlier and has been running the Physics Institute in Berlin for the last three years. Debye was among the first to study polymers, but Debye did not take Peterlin as his doctoral student because Debye and Stuart thought that the twenty-nine years old Peterlin was too old for the job and Peterlin just got one year available for his doctoral studies. Debye left Peterlin to Stuart, who was in Debye's office upon Peterlin's visit. Peterlin was probably humiliated a little bit, but there was no help available. In fact, he developed the excellent relations with Stuart very soon.

Peterlin stayed in Germany for a year with intervals after visiting his Slovenian home already as a full-time employee with a doctorate. He returned from Berlin to Ljubljana at the end of March 1939. In April 1939 and later with the decree of the Council of Ministry of Education signed on May 21, 1939, Peterlin was appointed as assistant professor of physics at the Technical Faculty after he returned to Ljubljana. He was confirmed at a council meeting on 23 June 1939. On 12. 3. 1940 Peterlin became assistant professor at the Faculty of philosophy while Zupančič was able to maintain leadership in both departments of mathematics and physics at the Philosophical faculty as well as at the Faculty of Technical Sciences. In 1939, Dr. Rihard Klemen as an assistant professor at the Faculty of Philosophy was set up for a freelance lecturer in experimental physics at the philosophical faculty. Next year on 25. 1. 1940 Moljk became an assistant at the Institute-Department of Physics on the proposal by R. Zupančič, because the Vrhnika native Moljk was stationed in Ljubljana and therefore the library under his leadership will be open in the summer, while Moljk was also a part-time lecturer in physics at the Faculty of Technology.³³⁰⁵

On 4 May 1940, Peterlin was elected an honorary physics lecturer at the Faculty of Engineering. At that time, Peterlin gave Moljk a theme for the doctoral dissertation from a current-flow double refraction (streaming birefringence) but Moljk never finished it even though Peterlin assumed

³³⁰⁴ Bartol, 1961, 106-107.

³³⁰⁵ Peterlin's personal map (archive of IJS in Podgorica).

most of Moljk's teaching duties. Later, Dr. Čopič was awarded his PhD in 1955. Čopič took over the similar Moljk's dissertation under the title "The Effect of Solvent on Optical Anisotropy of Velocities". Moljk had his hands trained to make them useful for experimental work, while Peterlin did not have that talent although Peterlin was not that bad as W. Pauli.

By the end of April 1939, Peterlin was dealing with spectroscopic measurements with the son-in-law of his doctoral advisor Friedrich Paschen, the professor Hermann Schuler (Schüler, * 1894 Posen; † 1964 Göttingen) in Kaiser Wilhelm Institute in Dahlem southwest of Berlin under Debye's directorship of the physics section. Schüler was a head of spectroscopy section and published fundamental research to determine the nuclear momentum of thallium and the isotope shift in the thallium spectrum which Wolfgang Pauli previously studied.³³⁰⁶

During the holidays from August 1939 until the beginning of the autumn semester, Stuart wrote a book called *Doppelbrechung* in Dresden, which was published only in 1943. In 1939, Peterlin published a discussion on the Determination of the size and axial ratio of ellipsoidal rigid particles from the data of internal friction at their dilute suspensions. He included seven graphs, which were illustrated by different models; he then compared them with real solutions.

That work was followed by a series of papers which Peterlin and Stuart prepared in Berlin in December 1938, and the last one appeared after Peterlin returned to Ljubljana, and Stuart went to the Physical Institute of the Technical College in Dresden. They published the papers in Geiger's *Zeitschrift für Physik* in 1939, and later Peterlin briefly wrote about them for the Collection of the Natural History Society in Ljubljana.

In 1938 and 1939, René Lucas noticed that castor (Ricinus) oil and linseed oil became bipolar if a sufficiently strong ultrasound wave was passed through them. The droplet behaves as a single

³³⁰⁶ Just before Peterlin's arrival, Schüler published with H. Gollnow. Über die Verteilung der Rotationszustände bei einem Elementarprozeß der Molekülbildung (keine Boltzmann-Verteilung) und die Änderung der relativen Übergangswahrscheinlichkeit, *Zeitschrift für Physik A Hadrons and Nuclei*, 1938, 432-432

crystal with the direction of the optical axis parallel to the direction of the wave propagation. Peterlin and Stuart assumed that a dynamic double refraction was due to deformation in linear flow. They proceeded from the theory of C.V. Raman and K.S. Krishnan (1928) but did not provide a good explanation for the nonlinear turbulent flow. Better results were predicted by the double refraction model as consequence of the kinematic arrangement of molecules in the field of a flowing liquid, which clearly explains the acoustic double refraction. The molecule of the liquid was described as a rotating ellipsoid.

Peterlin and Stuart improved Lucas's equation by focusing relaxation; molecules cannot follow the rapidly changing direction of force and are increasingly left unregulated. Acoustic double refraction is low in benzene, but it is larger in oleic acid. The writers also expected useful measurements for Ricinus and linseed oil. They used Sadron's axis orientation theories based on the nitrocellulose measurements. Stuart even photographed the arrangement of molecules in the solution in 1939.

30.1.4.3 Textbook

On 1. 9. 1939, the WW2 broke out which soon affected Peterlin's German ties. Both Supek and Peterlin were involved in their Ph.D. researches in Leipzig and Berlin with highly controversial pro-Nazi figures of Heisenberg and Debye. While Supek actively supported Partisans and opposed nuclear program, the Catholic Peterlin was more pragmatic. In 1971 Supek supported Croatian spring nicknamed Maspok, while Peterlin was unable to support the similar Stane Kavčič's plans in Slovenia as Peterlin already previously left for USA. Supek criticized F. Tuđman's post-communism mishmash, while Peterlin preferred to stay out of trouble, and to mind his own business in his physics managements.

In 1940, the professor Peterlin published a physics textbook for his students which was technically equipped by Peterlin's employees the Bulgarian absolvents of mining engineering studies Alexander Barliev and Georgi Kotov. The textbook had been mimeographed in 170 copies, but it was impossible to get any copy shortly after

the war. The individual copies were beautifully bound.³³⁰⁷

In his textbook, Peterlin divided classical physics in four parts: mechanics, heat, electricity (with magnetism) and optics. Peterlin did not write additional chapters, as was usual in high school textbooks where they loved to describe astronomy, atoms, and meteorology. Peterlin's textbook was typed only a year before Sirk's Book of Physics for Naturalists and Chemists. However, Peterlin's textbook was never printed similarly as Plemelj avoided publishing his textbooks for a long time. Peterlin missed the time or courage for publishing, although into his typescript textbook he manually introduced the additions and corrections over the years. In any case, all subsequent Slovene physical textbooks were derived from Peterlin's typescript.

Peterlin wrote the text from edge to edge and furnished it with numerous mathematical and experimental sketches. He composed 344 pages of A4 format in 56 chapters with additional three unnumbered pages full of improved images from the text. Modern physics, later physics II, was only introduced in the last four chapters of electricity (42. Glow discharge (257); 43. Electron beams from glowing metals (267); 44. X-ray (272) and 45. Radioactivity (275-280). Peterlin's modern physics also spread through his penultimate chapters about light entitled (54). Light spectrum (328) and 55. Quantum effects of light (pages 332-336).

In the case of discharges in gas, he scanned and pictured vacuum tubes in detail: "If we lower the pressure in a cathode ray tube with two electrodes (cathode and anode), at the pressure of a few centimeters of mercury and a few 100 V voltage we get bright, bluish red tape through the tube that becomes even wider with the falling pressure."³³⁰⁸ "Vacuum 10^{-5} to 10^{-6} torr (practically we can barely achieve any better vacuum) is a perfect isolator because it is missing the flow carriers, and we can translate the flow in it if we insert artificial carriers (by electrons and glowing cathodes)«³³⁰⁹

The X-rays were then and later the basic Peterlin experimental tool, and therefore he described them in detail: "In addition to medical applications, X-

rays are used in the technique of so-called rough investigation of the material. In this case, we are investigating to trace the inhomogeneity, cracks, air bubbles, slag inserts or other contaminants in castings, to investigate welded seams and heavily loaded parts of the structure. In this way, it is easy to test light metals (aluminium, magnesium, etc.) while up to a thickness of several cm we also research data for iron, copper, etc. But we only have success in thinner pieces (sheets of metals)..."³³¹⁰ His X-ray chapter section was intended to supplement the description of their diffraction and interferences of beams-rays of electrons.³³¹¹



Figure 30-3: The vacuum cathode ray tube in first Slovenian university textbook of physics (Peterlin, 1940, p. 261 and Appendix 1).

Peterlin noted Einstein's relativity theory only by the way with the equation describing conversions of mass into energy at the end of the chapter on radioactivity. "Especially large energies are found in so-called height rays, whose origins are not yet known. Near the surface of the earth this beam consists from very solid beams of rays γ , beams-rays of positrons, electrons and mesons. The maximum energies measured in these rays reach a value of $2 \cdot 10^{11}$ eV, which is the energy contained

³³¹⁰ Peterlin, 1940, 273-274.

³³¹¹ Peterlin's note written during the spring semester of 1950 inside his textbook issued in the year 1940 (Archive of the family Peterlin, kept by Tanja Peterlin-Neumaier).

³³⁰⁷ Message of Saša Svetina on 6. 12. 2006.

³³⁰⁸ Peterlin, 1940, 261.

³³⁰⁹ Peterlin, 1940, 262.

in the mass of the heaviest atomic nucleus ($m \cdot c^2$)."³³¹² The Styrian Victor Hess received his Nobel prize in physics for his research of those cosmic rays, but he and his Jewish wife left for USA in 1938 which gravely diminished the support of his work among Peterlin's German teachers. By later notes in his domestic copy of his textbook, Peterlin intended to insert a chapter on the physics of the atomic nucleus there.

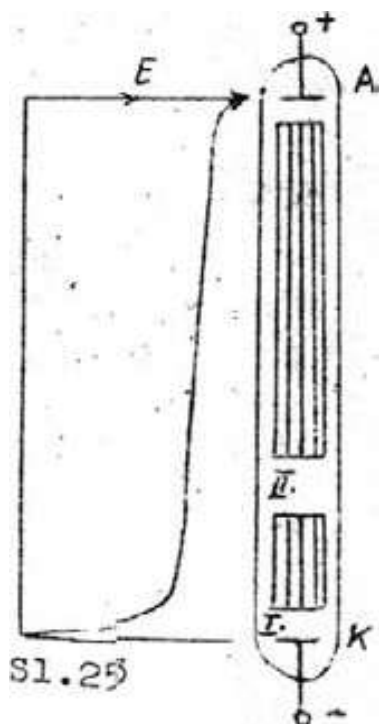

Figure 30-4: The X-ray cathode ray tube in first Slovenian university textbook of physics (Peterlin, 1940, 272).

Somewhat more, but again without mentioning the Jew Einstein, Peterlin wrote about the special theory of relativity in the subsection of the Doppler effect:

"Observations have shown that the Doppler effect depends only on the relative motion of the light and the observer, but it is absolutely unimportant fact who moves for example in the cases of moving sources of light observed on channel rays, or in the cases of moving observer in the cases of observation of astronomical objects and moving Earth. - This difference between observation and the above classic thinking (about idle ether) has culminated in the relativity theory which requires us to apply to the moving systems of the so-called Lorentz transformation obtained from the requirement that the light velocity in all equally

and linearly moving systems is the same. From this assumption we arrive at the conclusion that the length and the time (the four-dimensional space)³³¹³ change in the moving system." Later, Peterlin described a special theory of relativity in one of the first issues of the Ljubljana based Journal of Mathematics and Physics in 1951 when Einstein ceased to be a German persona non grata. He just felt that the students needed Einstein and not any more the ether. Peterlin's early aversion to Einstein's novelties might have been influenced by Kušar and especially R. Zupančič's critique of Einstein, and certainly also developed through Peterlin's experiences in Berlin where Einstein's data were slowly becoming a hostile part of Jewish non-Arian physics.

In the case of spectrum of light Peterlin continued to describe the ideas of grandfather of his future wife, Maks Samec the elder, who published about spectrum of light in 1871. Of course, Peterlin already introduced an elementary quantum of action, although he did not mention Planck by name.³³¹⁴ Peterlin specifically described the "band" spectra of molecules, but he did not mention his later major research field, the macromolecules. For this field of research, Peterlin definitively decided a few years later. In terms of quantum effects, Peterlin described in detail the fluorescence, phosphorescence, and photoelectric effects based on Einstein's law. Peterlin did not mention Stefan's radiation law which Peterlin later promoted by naming his institute by Stefan.

30.1.4.4 Occupation

In February 1941 Peterlin married mathematics teacher Leopoldina (Oli) Leskovic, whom he also met during student days and during their joint teaching at the Women's Real Gymnasium (Lyceum) and at the Ursuline Gymnasium. At the end of the war, she taught Bibiana Dobovišek, later married to Čujec, who studied under supervision of her husband Peterlin after the war, and then worked in the department of Darko Jamnik at the IJS.

In April 1941, Peterlin was briefly recruited to the army in the surroundings of Cerknica, but the front quickly collapsed and Peterlin continued with lectures under the Italian occupation in Ljubljana.

³³¹² Peterlin, 1940, 280.

³³¹³ Peterlin, 1940, 284.

³³¹⁴ Peterlin, 1940, 330.

In May 1942, the Italians searched for Peterlin's assistant Škerlak (Schkerlack) because of Škerlak's illegal distribution of forbidden resistance partisan news; because they did not find Škerlak they jailed Peterlin for two weeks.

In May 1941, Peterlin was already a member of the illegal domestic matrix committee of the OF (Liberation Front) at the University of Ljubljana, where he transferred action orders-papers to his co-workers of the Faculty of Philosophy and the Faculty of Engineering. The Main OF Board of the University of Ljubljana was first headed by prof. dr. Franc Šturm (Sturm, * 1881 Donja Košana; † March 31, 1944), the head of the Department of Romance Languages and Literatures, a representative of cultural workers at the founding meeting of the OF, a member of the Communist Party of Yugoslavia, and the Dean of the Faculty of Arts until the domestic Nazis took his life. He was replaced by another Littoral native, the founder of Slovenian comparative literature prof. dr. Anton Ocvirk (* 1907 Žaga by Bovec; † 1980).

In 1943, Senate of the University elected Peterlin as associate professor, but the Italian authorities did not confirm the election. The Italians did not have any special reason to dislike Peterlin except that he certainly was a Slovenian patriot. On 9 July 1943, Peterlin was re-elected as an honorary lecturer at the Faculty of Technical Engineering.

Upon disembarkation in Normandy, he was detained-arrested by Home Guard militia (Domobranci) in May 1944. On 7. 7. 1944 he was detained at the police station and released; on that day, he received a paid study leave until 30 September 1944, which was extended until 31 December 1944 on 12 September 1944. After his wife's intervention based on Stuart's letters with invitations to continue his scientific work, Peterlin was interned in Dresden during his academic study leave. There, with professor Stuart, Peterlin decided to study the big molecules with which he successfully dealt during next four decades. Peterlin worked in Dresden for three months again under supervision of the professor Stuart; this time he has already deliberately decided to explore large molecules, which he has successfully dealt with since then.

Until 1947, Peterlin, together with Stuart, published three of his ten papers, mostly in

Zeitschrift für Physik. Together with Stuart, he also shared a book on artificial birefringence in crystals. Peterlin did not experience the Allied forces' bombing of Dresden in February 1945, as he had previously travelled to Slovenia to spend Christmas holidays with his family. His return was delayed for a long time and thus he avoided that catastrophe.³³¹⁵ He worked in a knitting factory of a Volksdeutscher female owner in Radovljica near his half-sister's house; he never had so much leisure time in his life as in those Radovljica afternoons according to his own testimony. Of course, the Gestapo in Bled controlled Peterlin's work in Radovljica. On December 29, 1944, Peterlin thanked SASA Secretary Fran Ramovš (1890 Ljubljana-1952) from Ljubljana who assisted Peterlin and his wife in the last half of the year when his wife was pregnant with their first child. Peterlin wrote to him because he felt "much better to sit at home and not show around town". Peterlin again thanked Ramovš for his confirmation of his service at the University in a relatively courageous even somewhat revolutionary letter: "Highly respected Mr. Professor! ... It is very good for me, because now after a long time I can work again, that I must say that the emigration from Ljubljana was a blessing. After the war, all forces will have to be focussed that we will also create the conditions for scientific work in science in the University of Ljubljana, and I refer specifically to your help, since you already have so much experience in this regard."³³¹⁶

30.1.4.5 Professor Peterlin Organizes the IJS Using Vacuum Techniques

During the war, most of the equipment of the Physics Institute of Ljubljana disappeared or was destroyed. Immediately after the liberation, Peterlin and the assistant professor Anton Moljk began searching for material from the abandoned German military warehouses for their Physical Institute. They found only radar devices with cathode ray tubes. They used them for the voltmeters and amperemeters, which they had not

³³¹⁵Plenec, 2003, 6, Message of Tanja Peterlin Neumaier 2006.

³³¹⁶Peterlin's manuscript letter to Ramovš on 29. 12. 1944 on page and a half, Legacy inventory of Fran Ramovš, Library SAZU. For help, I thank the Librarian of SASA Drago Samec.

previously owned. All new apparatus in a physical practicum consisted of that material.³³¹⁷

On 1 June 1945, Peterlin from his posts at the Physics Institute and the Faculty of Arts proposed to the Ministry of Education in Ljubljana to send Moljk to study in the Soviet Union, England or the USA. In this, he particularly emphasized Moljk's wartime captivity in Italian prisons between April 7, 1941 and November 1, 1941, and Moljk's detention in Gonars concentration camp from March 7, 1942 to 11. 3. 1943, where Osredkar was also jailed from May 1942, although Osredkar later ceased to support Moljk. Moljk was sent abroad as a second scholar from the Physics Institute of Ljubljana. Moljk was in Basel in the summer of 1949, and he later transferred to Paris. In 1953 Moljk went to Glasgow for two years;³³¹⁸ Moljk covered the cost of his first year of specialization with his IJS scholarship, and during his second he used a scholarship from the University of Glasgow. In 1953, Kuščer was also nearby for five months in Birmingham studying the half-life and spectrum of short-lived isotopes with a British Council scholarship. Ivan Franjo Havliček (1906 Moravska Ostrava-1971 Novi Vinodolski) was sent to Switzerland in 1951. Havliček matriculated in Zagreb University but graduated and got his Ph.D. at Eidgenössische Technische Hochschule (ETH) in Zürich in 1932. In February 1944, I.F. Havliček became the assistant professor of physics and sub-chief of institute of physics of Technical faculty of Zagreb where his father Jaroslav Havliček (1879 Garešnica southeast of Zagreb-1950 Zagreb) also taught. In 1946, F. I. Havliček participated in the Cambridge conference on the physics of atonic nucleuses. F. I. Havliček's lectures in Zagreb were mathematically too advanced and there he did not show enough experiments, therefore the students mutinied against him. In 1950-1963 Havliček worked for Peterlin's institute as the head of four labs for concentration of isotopes, reactor technics, electronic (electrostatic) generators and optics.³³¹⁹

On 5 July 1945 Peterlin sharply protested in furry against the mechanics of his physical institute Josip Dermota. For twelve years, that man

³³¹⁷ Peterlin-Neumaier, 2003, 69.

³³¹⁸ Annex to Peterlin's Letter to Kraigher on 30. 9.1960, page 3a (material of the Peterlin family, kept by Tanja Peterlin-Neumaier).

³³¹⁹ Branko Hanžek. Technician Franjo Ivan Havliček (1906-1971). *Povijest i filozofija tehnike – radovi EDZ sekcije od 2012. do 2016*, Zagreb 2017, pp. 68-70.

supposedly came to work late, he was even stealing the material, especially during the relocation; so Peterlin demanded his firing.³³²⁰ It was a disastrous move, but Peterlin's daughter later stated that Peterlin was "a socially feeling guy" despite of that humiliating affair with Josip Dermota who obviously did not show enough respect for Peterlin's absolute authority. Peterlin was an authoritative guy who did not tolerate any opposition, but folks like Dermota and Moljk loved to make secret jokes about Peterlin's awful experimentations and similar handy abilities. There was also a huge problem with Anton Peterlin's relative the career officer Ernest Peterlin (1903 Ljubljana-20 March 1946) who was executed as a leading Slovenian Home Guard Quisling although the Nazis put him in Dachau for his ties with West in opposition to Leon Rupnik's (1880-1946) unchallenged Pro-German stance. In bloody finale Ernest Peterlin and his collaborator-antagonist Rupnik received just the similar kind of commies' bullet.

On 25 July 1945 Peterlin was re-appointed as a lecturer assistant professor at the Faculty of Arts, with the decree of the Ministry of Education in Ljubljana. On 27 July 1945, at a session of the University administration, he proposed a plan for a physical institute. On 25 August 1945 and on 7 September 1945, he was appointed as associate professor with a decree valued back to 1 July 1945.

At the end of August 1945, Peterlin, together with Moljk and Kuhelj, headed for Milan with Kidrič's three million liras in three suitcases for the purchase of vacuum research equipment. The volume of money put in the hundred lira banknotes was quite hilarious and, of course, very noticeable. This was the money of the government derived from the differences of exchange rates, and the president of the Slovenian government, Boris Kidrič, gave it to the Physics Institute after the mediation of his father, the professor France Kidrič, the president of the Slovenian Academy of Sciences and Arts and a full professor of Slavic studies since 1920. In Vienna France Kidrič met a staff member of gas distribution company Jelica Krušič and married her in Vienna in 1911. The relatives of Krušič were at home in Celje, from where they visited F. Kidrič during the First World War. France Kidrič's father-in-law and mother-in-law remained in Vienna, and the occupying powers

³³²⁰ ARS, SI_AS 1961, Box 1, Folder 3.

of Nazis moved F. Kidrič from the refugee prison to Viennese internment in 1944/45.

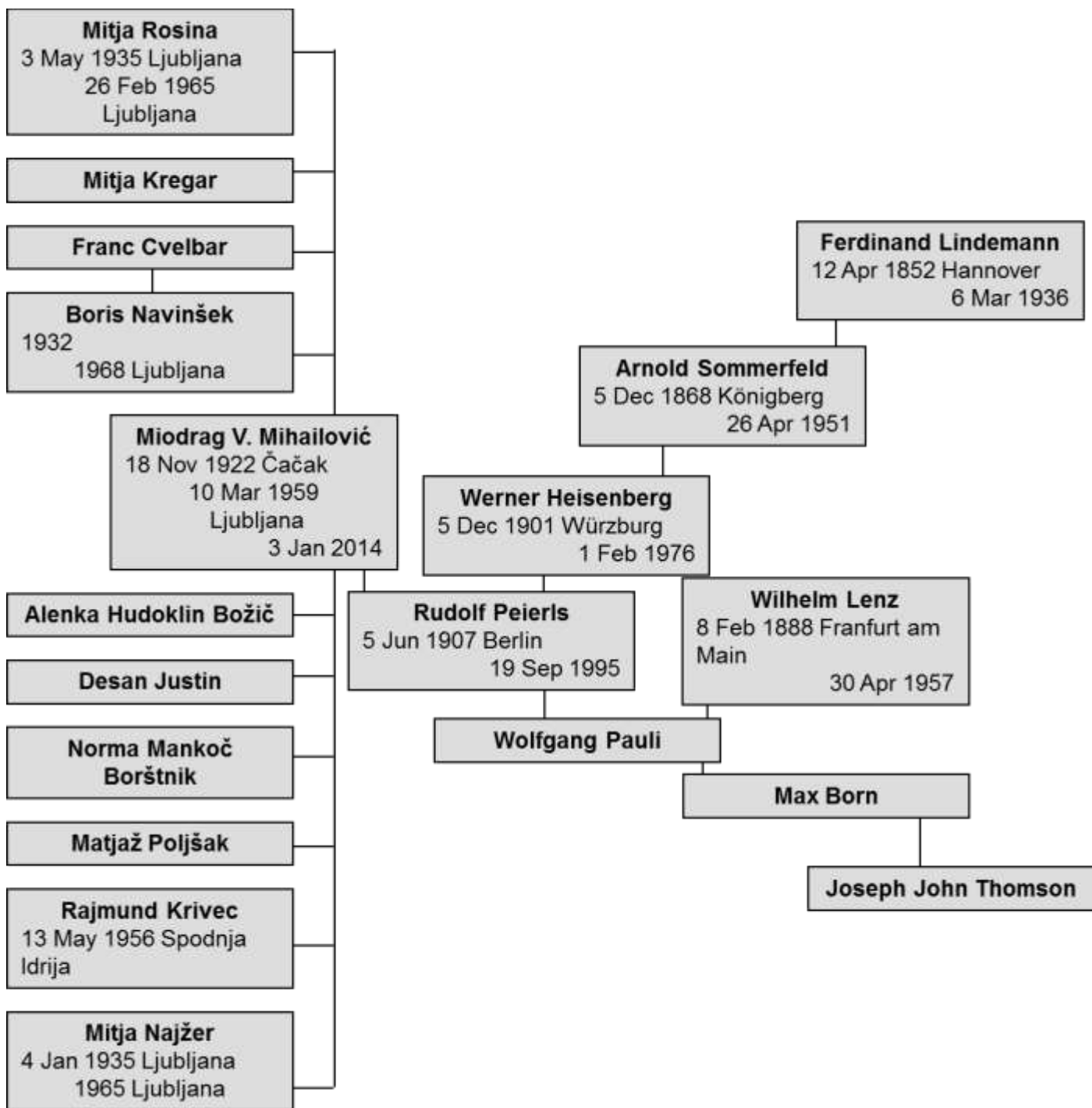

Figure 30-5: Academic descendants and ancestors of Miodrag V. Mihailović according to his Birmingham postdoc

Three university professors from Ljubljana, all of them named Anton, expected information from the party cell member in Trieste with instructions for their further journey. Unfortunately, the guy did not show up. Then they travelled by bus from Trieste to Milan without knowing that the Italians had started the routine checks of passengers in Vicenza on the previous day. The suitcases with money were taken away from them in Vicenza,

where they were detained for some time in military prisons barracks on September 1, 1945. Only half a million liras were later returned to Yugoslavia by the Italian bank. The money in the boxes of three guys named Anton seemed to be damaged, so the Italian authorities suspected it originated from the recently robbed burned Italian bank. As the native of Trieste areas Kuhelj spoke a good Italian language, but those skills did not help much.

In the prison Moljk supposedly shew "a severe vanity and a great misbehaviour", but Peterlin nevertheless proposed him later to a post of scientific associate of the SAZU.³³²¹ In November 1945, Peterlin and his companions were transferred to the refugee camp and then to the British military prison in Padua. They were only released on 21 December 1945 after the intervention of the University (17 November 1945) and mostly by the help of British parliamentarians visiting Slovenia. Boris Kidrič, after this breakthrough, said somewhat witty that science can be explored even without money, and Peterlin named his unsuccessful group as "three university awkward guys".

On November 22, 1948, Kidrič announced to Peterlin the Italian remittance for half a million liras, and Peterlin promised to deliver a list of necessary literature and tools for the Physical Institute. On December 22, 1948, Kidrič described his intervention about half a million of the lost three million liras in the Banco d'Italia in Vicenza. The money was available to the Physical Institute of the University of Ljubljana, which became part of SAZU in 1946. The total amount is supposed to be spent on the purchase of the "instrumentation for neutron apparatus" after the settlement with the Yugoslav Embassy in Rome.

Peterlin's half a million liras was deposited in Vicenza after Kidrič's mediation succeeded in getting money back with the help of Yugoslav consulate in Milan in 1952. Peterlin personally travelled to Vicenza by the train, this time much more carefully, and spent money on purchasing devices for the Physical Institute. Moljk, Kuhelj and Peterlin signed the authorization to raise money on 9 May 1950. On 6 June 1952, the Vicenza Bank confirmed its willingness to pay. On 2 October 1952, Antonije Filipić explained in writing to Peterlin how to purchase devices for the Physical Institute, which he will buy with this money. Antonije Filipić got his Ph.D. with the thesis *La Jugoslavia Economica* at Università Commerciale Luigi Bocconi in Milano in July 1921.

On 8 October 1952, Peterlin wrote to vice-consul Vojko Santrač in Milan about his fears because he

³³²¹ Annex to Peterlin's letter mailed to Kraigher on 30. 9.1960, page 3a (material of the Peterlin family, kept by Tanja Peterlin-Neumaier).

was already once imprisoned for several months in Italy with the same money involved.³³²² On November 24, 1952, the engineer Evgen Černigoj (* 1908 Cesta by Vipavski Križ) from the Milan Consulate explained to Peterlin how to ride trains to Vicenza and how to raise money there. Evgen Černigoj studied in Ljubljana in difficult conditions to graduate as an electrical engineer. Due to the economic crisis, he was unable to get a job and was only employed as an assistant to the Laboratory for Materials Research at the Technical Faculty in Ljubljana in 1938. Because of his activity against the Fascist Italian occupier, he was arrested in 1942. After the war, he carried out various tasks of economic and administrative character. Thus, he was also a councilor at Yugoslavian commercial attaché in Milan, and a member of Yugoslavian reparation commission with Ivo Lah's calculations involved which enabled Evgen Černigoj to give a good insiders' advices to Peterlin who was just one single day Evgen Černigoj's younger. During this time, Evgen Černigoj worked at the Institute of Electrical Engineering in the laboratory for the development of electronic components for a while. Later in 1953 he took over the post of director of the barely emerging Vacuum Laboratory at the Faculty of Electrical Engineering and remained there until his retirement in 1971. Under his leadership, the laboratory became a powerful research and development center in which the Yugoslavian vacuum technology has its strong scientific support, while at the same time IEVT has created a reputation in the foreign circles. Evgen Černigoj participated in vacuum congresses. At the 6th vacuum congress, 13th Bulletin-anthology of the Congress was dedicated to Evgen Černigoj for his organizational work.

On 11. 12. 1945 the University Senate of education proposed Peterlin for a full professor of theoretical physics at the Faculty of Arts of the University of Ljubljana and he was promoted on 5 January 1946. In 1945, he had a Slovene assistant who was native from the now Italian state neighbourhood. The assistant suffered a fatal accident down the stairs of the University.³³²³

In 1946 Peterlin was appointed as an extraordinary and in 1948/49 as a regular member of the SAZU.

³³²² ARS, SI_AS 1961, Box 1, Folder 3.

³³²³ Ivan Vidav, letter to Tanja Peterlin-Neumaier, 10. 7. 2006 (GDP).

At that time the disputes with the Cominform (Informbiro) were settled and with them the scientific situation in Yugoslavia significantly improved. At the end of the year, the uncle of Peterlin's wife Maks Samec became a regular member of the SAZU in the same class for mathematical, technical and physical sciences as Peterlin. From 1946 to 1948 Peterlin was the Dean (1946/47) and the Vice-Dean (1947/48) of the Faculty of Arts in Ljubljana.

On 10 January 1948, Peterlin signed a "justification for the necessity of establishing an astronomy institute at the Faculty of Philosophy of the University of Ljubljana", which enabled the employment of Dominiko. On 14 September 1966, Dominko among the first visited the astronomical observatory in Bucharest.³³²⁴

On 145 November 1948, Peterlin was able to attend a scientific conference about the Large molecules in solution (Les grosses molécules en solution) in Paris in honor of the recently deceased Langevin and Perrin. The invitation was supported by one of the editors of *J. Chimie physique*, a polymers physicist Charles Sadron from Strasbourg.³³²⁵ Peterlin met him shortly before the war in July 1939.

At the beginning of December 1948, Boris Kidrič instructed Peterlin to collect data on nuclear energy. In February 1949, at a meeting with Kidrič in Belgrade, Peterlin undertook organizing a nuclear institute in Ljubljana, whose main task was to construct a reactor. In planning, he came into conflict with the leading physicist in Belgrade, Pavle Savić. In 1932, Savić graduated in Physical Chemistry in Belgrade and measured the radiation under supervision of the professor Jovanović. From 1934 until the war he worked with Irena Curie and Frederic Joliot to prepare the discovery of the fission of the nucleus in Paris where Tito occasionally used Savić's flat. Irene and Joliot followed their leftist ideas. During WW2 Savić was in the partisans' unit as the head of the highly confidential cryptography department of Tito's headquarters and vice president of the Executive

Board of AVNOJ.³³²⁶ In 1945, Savić became professor of physical chemistry in Belgrade, in 1946 a member of the Academy, and from 1971-1981 its president. As the former head of the Confidential Tito's Headquarters, he was trying to direct the development of physics in Yugoslavia. He wished to produce a nuclear bomb as director of the Vinča Institute. After Kidrič's death Peterlin was somehow hiding his seemingly unpromising research of macromolecules from Savić during his visits combined with hunting in Slovenian forests where he disliked macromolecular polyvinyl plastic bags. Savić represented nuclear physics as the sole goal. Thus, only physicist M. Čopič and chemist G. Mohorič with their research of the double refraction in flow (streaming birefringence) or the synthesis of polyhedrons were awarded their Ph.D. from Peterlin's basic field. Later, Peterlin sent Čopič to the training in the United States to be able to dedicate himself to the reactors.

Peterlin's best association with politicians in Belgrade was Tito's secretary general between 1953-1958, the lawyer dr. Jože Vilfan,³³²⁷ Peterlin's juvenile friend and Carniolan student of Peterlin's uncle. Vilfan was the son of the Trieste lawyer and politician Josip Vilfan (* August 30, 1878 Trieste; † March 8, 1955 Belgrade), and he attended the grammar school in Kranj in 1919-1926. Vilfan's mother was the native of Kranj, so she came on a summer vacation in Kranj. Vilfan and Peterlin's mothers were familiar from their juvenile days; so, both boys met each other, they played together and walked by the Sava river.

In 1929-1932 Vilfan studied law in Ljubljana. He got his degree in 1932 and promotion next year, so they shared time with Peterlin during their student years. Of course, their scientific interests were completely different. They often discussed Serbian temperaments and Peterlin once stated that Serbians often make impossibly higher goals for themselves to gain, which the stable small narrowminded Slovenians do not.

The former student of chemistry, Boris Kidrič, knew the capabilities of his four-year-older

³³²⁴ Milan S Dimitrijević, 2005, *Serbian astronomers in science citation index in the XX century*, Beograd: Zadubina Andrejević, 177.

³³²⁵ Peterlin's letter to Lado Kosta signed on 23. 8. 1955.

³³²⁶ Osredkar, Polenec, 2000, 22; American Chemical Society, September 1978, last page.

³³²⁷ Peterlin's letter to Joža Vilfan (Vilfan, * 6. 7. 1908 Trieste (Trst)) mailed from Detroit to Beograd 23. 7. 1955, which was not mailed as he wrote another letter instead of that one (GDP; SBL, 4: 469).

Peterlin and allowed him to continue with the research of large molecules within the framework of the Physics Institute. The institute was named Jožef Stefan after Peterlin's proposal. Peterlin headed it for a whole decade until 1959. The coincidence was that he died 158 years after Jožef Stefan's birthday (1835-1993). Peterlin learned experimental approaches from Sirk. Although he initially followed him in quantum mechanical experiments, Peterlin was among the first to discover greatest potential for the investigation of solid matter and new materials. He thus focused on the research of macromolecules (common plastics and synthetic fibers) and was, after the Second World War, by far the most renowned Slovenian physicist. Thus, at the time of the establishment of a nuclear institute in Ljubljana, there was no other choice, and Peterlin became the director with wide powers, although his research field was far from a nuclear bomb. The decision was correct, as Peterlin showed an extraordinary gift to the organization and quickly developed an extremely effective scientific institute on the Western models.

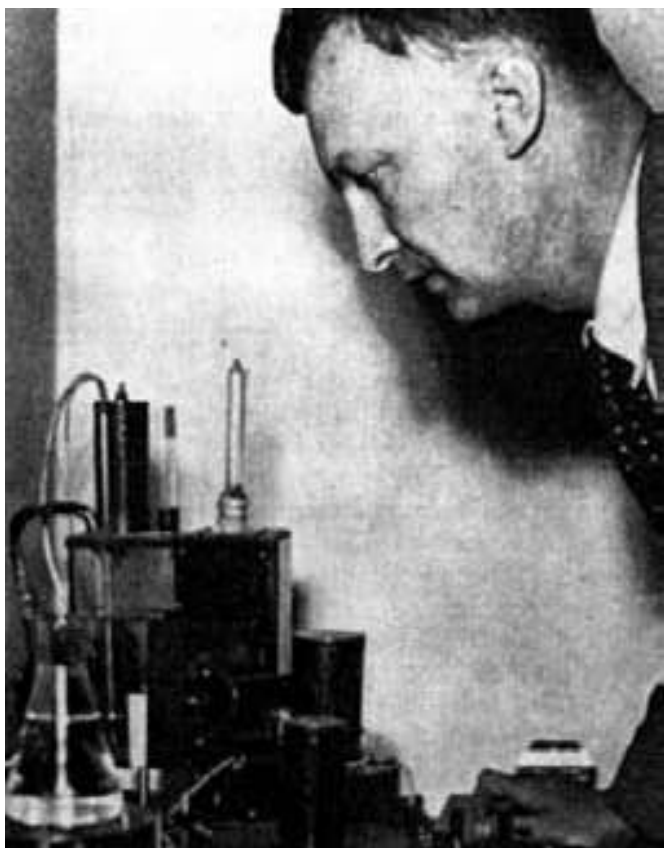

Figure 30-6: Peterlin experimented in the 1950s

Physical Institute premises were initially at the SAZU. Between and in 1949-1953 they built a new building at the intersection of Jamova and the Jadranska streets. The workers in the construction

of the Institute were mainly prisoners, among them the relative of Gottschee forester Anton Prelesnik the physicist Anton (Tone) Prelesnik who was imprisoned for his careless political talk. In July 1955, he worked as a practitioner in Havliček's Laboratory. In 1959 he graduated in Kuščer's class, and in 1960 he published in the same topics a report on NMR research in Rochelle salt in *J.Chem.Phys*, together with Blinc.

30.1.4.6 Macromolecules

On Prešeren's day in 1953, the new Physical Institute was ceremoniously opened, which since then was named after Jožef Stefan. Two months after the ceremony Peterlin's mighty patron Boris Kidrič died. In that time on 7 February 1953, just one day before the opening of new IJS buildings, Peterlin published his calculation of the persistent length of the DNA molecule and its elastic constants, which he sent from Ljubljana to a leading magazine *Nature* on 5 June 1952. He used Bunce's measurements of the scattering of light in DNA solutions done for her doctorate with Doty at Harvard, Cambridge, Mass. In 1953, two months after Peterlin's announcement, Watson and Crick published the discovery of a double-ended DNA in the same magazine, and Peterlin's calculation again became interesting forty years later.

Peterlin presented his findings for the first time at the International Macromolecular Colloquium in Strasbourg between 9 June and 12 June 1952 in relation to the measurements of the light scattering of Mrs. Barbara H. Bunce married to McGill and Ernest Peter Geiduschek (* 1928 Vienna), that is, immediately after Peterlin sent them to *Nature*. Already in 1951, Havliček in *Nature* reported on the determination of the wave surface for known spherical aberrations, while Moljk reported in the prestigious *Phil.Mag.* in volume 36.

On 5 August 1952 Peterlin sent his report from Strasbourg and published it in Doty's *Journal of Polymer Science* in April 1953. At the same colloquium, Doty presented his measurements of scattering, which, of course, encouraged Peterlin to make new announcements, as he improved his calculations during the following decade. As a graduate student Doty joined the Manhattan project to become an associate professor of chemistry at Harvard between 1950-1956, then a professor. Between 1967-1970 he was a head of the

Department of Biochemistry and Molecular Biology, and Edward Mallinckrodt (1878 Saint Louis-1967) professor of biochemistry since 1968. In 1973 he founded Robert and Renée Belfer Center for Science and International Affairs at Harvard as its first director. Shortly after her doctorate, Bunce was employed at the Oberlin College chemistry department south of Cleveland. With Doty's measurements, Peterlin studied the scattering of light in protein solutions in the second part of his discussion on the Physics of High Polymers. The epoch-making monograph on macromolecules was edited by Stuart in 1953. Peterlin contributed four chapters, among them the longest on the Artificial Double refraction together with Stuart.

In chapter twelve, Stuart and Peterlin determined the characteristic constants of submicroscopic particles from the measurements of artificial double refraction and internal friction; the connection between the internal friction and the measurable properties of the substance was like the one developed in the previous century by S. Šubic's criticism of Clausius and Boltzmann. In the case of a double refraction in flow (streaming birefringence) Peterlin re-introduced the model of a free torus. He compared it with the results of experiments. The artificial double refraction was divided into electrical (Kerr's), magnetic (Aimé Cotton-Henri Mouton's) and dynamic or current or acoustic double refraction of flow (streaming birefringence, Maxwell's).

In chapter 6, Peterlin described the scatterings of light in mixtures and solutions of macromolecules (simple and repeated scattering). Stjepan Jakšeković performed similar measurements on seawater already in his Zagreb dissertation in 1932, while several measurements were published by Marin Katalinić (1887 Trogir-1959 Skopje) at Zagreb University physics institute and P.J. Jurišić of the Physiology Institute of Medical faculty of Zagreb in 1935-1938. Peterlin also quoted the early work of Lars Onsager on the viscosity of the suspension of several spheres published in 1936.³³²⁸

In the meanwhile, the foundations for both faculty buildings in the Jadranska street next to Peterlin's institute have long been waiting for the start of construction. In 1960 they built the building of the

Faculty of Physics at the Adriatic (Jadranska) street no. 19, while the anticipated building of mathematics was waiting for its foundations as the Computer Center; the planned intermediate pavilion never saw a white day.³³²⁹

In 1955 for nearly eight months from mid-May to the end of December Peterlin was "guest professor" on study leave under supervision of the former collaborator at University of Paris from 1933 to 1937 the Jewish professor Wilfried Heller (1903 Bad-Dürkheim-1982 Huntington Woods suburb of Detroit) from the Chemistry Department of the Wayne State University in Detroit, precisely at the time when the writer of these lines was born somewhere to the west in San Francisco. Peterlin led the work of the IJS with numerous letters from the USA. His wife wanted to visit him, but she wrote in her visa application that she was a member of the SZDL, which, as a civil servant, she must have been. The request was not granted to her during then presidency of Eisenhower and vice-presidency of Nixon.³³³⁰ Peterlin was a guest lecturer at the Department of Chemistry at the Wayne State University in Detroit, with the participation of the head of the project, Professor Wilfried Heller, and visiting professor from the University of Osaka and Tanaka Masayuki Nakagaki (1929 Fukuoka Prefecture-2008 Kyoto). 31 syllables poet Masayuki Nakagaki worked in USA with Wilfred Heller of Wayne State University in 1955-1957 and in 1968-1969. Peterlin was engaged with the same problem at the meeting of the American Physical Society in Philadelphia on 16 March 1957.

Based on Debye's (1931) model of the molecule as a free-dipping torus, they tried to explain the results of experiments with the angular distribution of unpolarized light. The symmetry of the ellipsoid was found in the end section of the macromolecule, the ratio of the axes increasing with the segment size. They determined the mean square of the distance between the ends and its alteration with the size of the segment used, that is, the statistical form of the macromolecule and its variation with the flow. They designed a model for scattering light on a curved macromolecule consisting of supposedly isotropic parts like pearls in a necklace. For small deformations, the

³³²⁹ Saša Svetina, message on December 6, 2006.

³³³⁰ Message of Tanja Peterlin Neumaier, message on December 6., 2006.

³³²⁸ Courtesy of Rudolf Podgornik.

computation was easy, but for large deformations it was necessary to perform numerical integration, the results of which were presented in eight graphs using the Wayne State University computers. On October 25, 1956, Čopič and Peterlin published their invention of a double capillary viscosity meter together with a photograph in the *Bulletin Scientifique* of the Academic Council of Yugoslavia, which Peterlin edited since 1953. In October 1958, Peterlin reported on shortrange and longrange interactions at Linear macromolecules based on scattering of light and X-rays. Günther Kratky's (1919 Faak am See near Villach (Beljak)-1984 Graz) and his Viennese teacher Otto Porod's (1949) Austrian worm model still seemed better than others, but Peterlin again warned that the distribution was not Gauss's, and thus has some of the advantages over the older Hermann Staudinger's statistical dumbbell-model handles designed by ETH student turned Basel professor Werner Kuhn (* 1899 Maur am Greifensee; † 1963 Basel) and his talented doctoral student Hans Kuhn (* 1919 Berne; † 2012) in 1943. Hans conducted his postdoc with Linus Pauling and N. Bohr.

In 1959, Peterlin published his *Determination of the Size of Molecules by their lighting data* in booklet at the prestigious Pergamon Press, together with a sketch of a measuring device drawn up at the IJS. In 1959, Peterlin re-studied the electro-distribution of macromolecules. After Debye's promising discovery in 1954 it was used for the dissertations of Poberaj (1955) and Ribarič on 16 March 1959.

During an intensive study of macromolecules, Peterlin was forced to study reactor physics and accelerators as well. At the IJS Betatron Seminar, the lecturer once reported on the electron path through a rather dense system of dipole and quadrupole magnets. At the end of the seminar, Peterlin stated that the results were wrong because they did not coincide in the first approximation with the path of analogous light rays through prisms and lenses. On 28 October 1953, Supek announced to Peterlin the Zagreb lectures by the head of the cyclotron group of the French Atomic Energy Commission P. Debraine. The French cyclotron had the most successful performance in Europe at that time. On 3 November 1953, Peterlin reminded Supek that a year ago Barbarić and his colleagues had removed all the support for Samec's Chemical Institute as well as for M.

Vidmar's Electrotechnics Institute, which were established by Kidrič, although both should prepare practically utilization of nuclear energy. Supek, unlike his colleague from Zagreb institute the electro engineer Marcel Lažanski, did not attend a conference in Geneva, where Livingston from the Brookhaven National Laboratory and CERN Director Huib J. Bakker of the Amsterdam Institute of Atomic and Molecular Physics questioned Supek in person. Bakker was even a bit angry because Supek recalled Lažanski from Geneva where Marcel Lažanski held permanent post from 1965.

In 1952, Livingston together with the great-grandson of Emil Heinrich du Bois-Reymond the Jewish Ernest Courant (*1920 Göttingen) and independently of the two years earlier efforts of Nicholas Constantine Christofilos (Νικόλαος Χριστοφίλου, 1916 Boston-1972), published the idea of strong focusing as the basis for the work of all subsequent powerful accelerators. After the first model of the glass, Lawrence, with the help of his student Livingston, assembled a second cyclotron from the metal. With a 2000 V voltage, it could accelerate hydrogen ions to 80 keV energies. In his doctoral thesis Livingston proved the utility of the principle of cyclotron resonance on 14. 4. 1931. Lawrence and Livingston were the first to accelerate protons over 1 MeV; but they did not break the nucleus of the atom before Cockcroft and Walton success in the British Cavendish Laboratory.

In the summer of 1959, Livingston, as director of the 6 GeV accelerator in Cambridge which was used by the researchers of Harvard and MIT, visited the IJS to talk about further Dekleva's specialization in the USA. However, the new director of the IJS, Lucijan Šinkovec nicknamed "a valve" by the local bicycles' fans changed his mind overnight and called Dekleva home. Ranković demanded Lucijan's construction of the Ljubljana reactor.

On 7 November 1953, Supek wrote to Peterlin that he would support the independent Samec's Chemical Institute, although in Zagreb all such studies were united in the Ruđer Bošković Institute. At the same time, he asked for Peterlin's help on the question of the Zagreb 16 MeV cyclotron, which, according to some rumors, Pavle Savić and Stevan Dedijer would like to have in

Vinča produced by Philips for a million dollars, which would be a "heavy attack" on Zagreb, where, after the approval of Kidrič in 1950, they have built such a device together with the factory "Rade Končar" with only 10% of the foreign currency funds under the leadership of Supek as the youngest member of the JAZU. Tito personally pushed the button commissioning Supek and Lažanski's Zagreb cyclotron on October 25, 1962.

On 20 November 1953, Peterlin congratulated Supek for Supek's new book, "The project of cyclotron 16 MeV". In fact, Vinča got a cascade generator. On 7 December 1953, Peterlin wrote to Supek to inform him that Pierre Debraine from Faculté des sciences de Paris could speak in Ljubljana on 11 December or 12 December 1953, if he travels from Zagreb by train; but if he uses airline, it would not be rational to organize the matter because of the excessive costs. In fact, Debraine lectured in Ljubljana on Wednesday, December 11, 1953 at 10:00 am, and two hours later, they celebrated Plemelj's 80th anniversary, as Peterlin reported to Dedijer on November 20, 1953. Two years later, a writer of these lines was born. Peterlin suggested to Supek to meet on the train for their joint trip to Belgrade to overcome the issues that will be discussed with Svetozar Vukmanović – Tempo (* 1912 Podgora in Montenegro; † 2000) in Belgrade, especially on the Administration of Mines, probably the mines of uranium ores. On 27 January 1953, Dedijer invited Peterlin to come to lecture in Vinča several times in 1953. On 26 February 1953, Peterlin wrote to Dedijer about the opening of the IJS as he described in Ljubljana newspapers and in the journal Borba. He praised the return of a great connoisseur of the reactor problems Dragiša M. Ivanović, who later published some philosophical books, and with the Marxist concept of self-motion came into serious conflict with Kuščer in the mid-1970s. During the first post-war years Ivanović was Savić's assistant and opponent of the mainstream quantum and relativity theory from Marxist standpoints. Peterlin also mentioned recent arguments at a meeting in Belgrade as unproductive attempts of uneducated guys to prove the facts, while they are all too little aware of the realities of reactors. On Dedijer's complained about the lack of a report about Peterlin's trip to the United States, Peterlin assured him that, at the request of his hosts, he was only dealing with macromolecules. He disliked the affairs of Mirjan

Gruden (1910 Ljubljana-2001). After his diploma in Ljubljana in 1937 and his studies in California in USA, Gruden first worked with the IJS, and then suddenly Gruden was supposedly unfairly hired in Vinča. Nor did Peterlin approve Ranković's handling the precise extremely costly measurements of uranium content in the Idrija ores that are not accessible to Slovenes. He also mentioned the CERN proton synchrotron leader O. Dahl's offer of assistance in the production of heavy water. On 2 April 1953, Peterlin asked Dedijer to send the professor Pieter Frits Abraham Klinkenberg (1915 Amsterdam-2005) from Zeeman's Laboratories in Amsterdam, who will be in Vinča for three weeks. Peterlin wished to have Klinkenberg in Ljubljana to present to the selected experts the theory of the shell as a model of nucleus for one day on 8 April 1953. At that time, Dedijer's deputy Ž. Petrović was also visiting Ljubljana.

On 2 March 1953, Carlo Salvetti and Aldo Pontre of the Istituto Nazionale di Fisica Nucleare at University of Milan announced that they could not visit Ljubljana and Belgrade. On February 25, 1953, Heisenberg wrote to Dedijer that he would like to come to Belgrade and Zagreb after the conference in Geneva at the end of May. Heisenberg visited the IJS in 1955, when Črt Zupančič came to pick him up Zagreb with a driver in the official vehicle.

On 27 April 1953, Peterlin asked Dedijer upon the visit of Charles A. Berthelot from Bureau Central de Mesures Nucléaires (Euratom) in Geel in Belgium who just arrived in Belgrade. Peterlin wished to host Berthelot in Ljubljana for 4-5 days and for the same number of lectures on co-determination coincidence measurements. Peterlin wrote to Savić about the visit of the only French participant at Fermi's Chicago reactors and at Manhattan USA based project the Jewish father of French atomic bomb in 1960 Bertrand Goldschmidt (1912 Paris-2002 Paris), while Peterlin also asked for details about the work in Vinča.

Peterlin prepared a report for Physikalische Blätter and Physics Today along with a description of the IJS and the Supek's Report of the Ruđer Bošković Institute. On 12 May 1953, Dedijer complained to Peterlin that two or three months ago, when the ministry of interior and Vinča collaborator Bojan

Zaletel (* 1920 Postojna; † 1981 Kranjska Gora) wrote about Stefan and the Physics Institute, Osredkar tried to obtain Zaletel for work in Ljubljana as Zaletel was on his way to specialisations in Paris in 1953. Dedijer did not feel right and mentioned "the procedure one year and a half ago, when another guy named Moljk asked to work at our Institute (Vinča), and when we responded in writing to Moljk, which you (Peterlin) can get that copy whenever you want. Dedijer welcomed Moljk's proposal on condition that Moljk's boss Peterlin is informed of it." Dedijer therefore proposed a kind of fair-play in hiring the experts in both institutes.

Dedijer regularly wrote Osredkar's surname Osretkar, according to Vuk Stefanović Karadžić's principle "write as you speak." Peterlin did not even try to exaggerate too much about Zaletel in his letter dated May 18, 1953, but he wrote, "when you mention that Moljk's offered himself to Vinča, I must tell you that I have only learned about this from your letter, because he never said to me about that. Your position was completely correct in his case." Certainly, Peterlin had too little politics skills to see how Dedijer checked the terrain: the docent Moljk was often in Belgrade as a delegate at atomic energy meetings, and the Belgrade-based folks had already chosen him for Peterlin's replacement, even though Moljk would wait another five years to fulfil his secret wish supposedly with a lithe help of his friend Tito's dentist. In fact, Peterlin and Dedijer will be very soon forced to escape abroad.

On 11 June 1953, Moljk together with Lieutenant Colonel Gajić (later major-general of air forces Pavao Gajić (* 1923), Kosta and Osredkar attended a meeting on nuclear energy, as well as an inter-institutional meeting in Zagreb on 6/1/1953 and in Ljubljana on 9 February 1953, 7. 5. 1953, and 8. 5. 1953 together with Peterlin, Havliček, Jamnik and Osredkar. By 25. 4. 1953 they determined that the reactor needed 7 tons of heavy water and 2 tons of uranium ore, like the the first French atomic reactor Zoé (EL-1) built at the Fort de Châtillon in Fontenay-aux-Roses suburb of Paris in 1947. On August 24, 1953, Peterlin reported to Dedijer about his visit to Niels Bohr's fourth son, the physicist Aage Bohr, who would take another student to work in Copenhagen besides Črt Zupančič in December 1952-1954.

On September 1, 1953, they sent from Ljubljana the IJS Reports to Dedijer. On 11 September 1953, Peterlin reported to Dedijer about the conference on accelerators in Zagreb with Alfvén, Gogard and Odd Dahl of the Carnegie Institution in Washington. Due to the changed situation after the construction of the Zagreb cyclotron and due to lack of foreign currency, the conference was later cancelled and only Debraine was invited.

On 20 November 1953, Peterlin wrote to Stevan Dedijer about dr. Otto Kofoed-Hansen (1921-1990), Bohr's co-worker, who will be the guest of the Dedijer Institute for the examination of the structure of matter for two weeks in Belgrade, and could arrive to Ljubljana on December 17, 1953, after his lecture in Zagreb on the previous day. On 26 November 1953, Peterlin sent Dedijer the book *Secrets of the Atom* of the writers Osredkar, Čopič and Kosta.

On 4 December 1953, Peterlin reported to Dedijer about Matteucci from the University of Maine, who gave lectures in Ljubljana on European mass spectrometers, while Albert Jan Staverman (1912 Bussum-1993) from The Hague applied physics TNO Institute for Plastics lectured on relaxation phenomena and plastic masses. In the spring of 1954, Peterlin announced a possible visit by Sadron and Per Claeson, the successor to Göte Swedberg at the institute in Uppsala. A week ago, Dekleva returned from work on mass spectroscopy in Mainz and could come to Belgrade in December 1953. For the Swede Harry Brynielsson (1914 Stockholm-1995 Vaxholm), Peterlin considered that he might hide some special methods from other researchers.

The state Defence Secretary carpenter turned general Ivan Gošnjak (1909 Ogulin-1980 Beograd) submitted to Peterlin the Rules on Nuclear and Chemical Weapons, and Moljk responded in writing to him, including on the notes on explosion of the bomb and on the irregularity of radiation for the telephone network. The JNA provided a list of experiments in nuclear physics that would be of interest to the army.

On 27 November 1953, the annual reports were published with papers of Havliček, Kosta, Moljk, Peterlin (double refraction at flow (streaming birefringence), scattering of light on the particles

of the PVC sample) and Kosta. Pičman was gone, and Perman was at the army as soldier.

Peterlin traveled by boat in both directions, since the Yugoslavian firm Putnik had badly arranged the reservation for him, so he had to buy the his tickets from his own pocket. Otherwise, ZKNE granted him \$ 390 for his trip to the US and an additional \$ 100 for his way to Detroit. In September 1955 Peterlin met with the great advocate of the peaceful use of nuclear energy Walker Lee Cisler (1897 Marietta, Ohio-1994), the president and CEO of Detroit-Edison Co. which Fermi founded in cooperation with other companies in 1963. Cisler contributed money, so Peterlin could extend his stay in Detroit for two months. From 12 December to 16 December 1955, Peterlin attended the Nuclear Science and Engineering Congress in Cleveland. On 30 April 1955, Beograd educated electronic engineer Slobodan Nakićenović (1916-1996 Vienna) wrote to Peterlin a letter which Peterlin received on July 5, 1955 and wrote back immediately. Nakićenović reported problems of interregnum in the IJS; it is necessary to appoint a director and administration as soon as possible. On 5 July 1955, Peterlin replied to Nakićenović from Detroit that only now, after six years of work at the organization, the IJS discovers something new, since so far it has published years old achievements only. During this time, Havliček ceased to be a member of the IJS Governing Board.

On 14 May 1955, Peterlin recommended Nakićenović to send Osredkar to study in the United States while eventually replacing Havliček. So, Savić will be satisfied as the Croatian Havliček was not Savić's best friend. During Peterlin's stay in the US on 16 May 1955, at a meeting of the Scientific Council of the IJS, a new statute was adopted with only three bodies: The Administrative Director, the Scientific Council under Peterlin's Presidency and the Council, later the Board of Governors. This was a real turning point, since Peterlin, Supek and Savić, as heads of scientific councils, did not have any real power, but Peterlin because of his fame nevertheless retained informal power. During the change, Peterlin stayed in the USA almost without an accommodation in IJS. IJS was left without a legitimate basis, as Nakićenović delayed the appointment of Peterlin and the IJS Governing Board. A lawyer named Karol Kajfež became the

administrative director. Kajfež therefore left his service for railways.

Osredkar together with the secretary Greta Novak came to the Institute from SUZUP under the director Sokol leader and Osredkar's fellow radio Kričač activist Ivan (Miloš) Brelih (Mihael, Mitja, 1916 Trebnje-2002 Ljubljana); Osredkar no longer had any administrative function in the IJS since Peterlin has dismissed him as his assistant. Prior to his return to the city of Ljubljana the electro engineer Brelih worked with ZKNE in Belgrade, where he was replaced by the engineer Barbarič who published the book *Nuklearna energija i njena primena* in Beograd in 1961.³³³¹

On 18 May 1955, ZKNE postponed the appointment of Peterlin as administrator and the Managing Board of the IJS; Peterlin was thus "de facto put deprived of his job, and IJS was put out of the law", as Peterlin complained to Ranković in a somewhat broken Serbian language on June 17, 1955. The discrimination of the IJS was due to the proposal of Savić, which Peterlin emphasized at the same time in the letter to Nakićenović, as Savić believed that during Peterlin's departure to the United States they should penalize both Peterlin and the IJS.

On 21 November 1955 Peterlin wrote to Nakićenović from Detroit about his lectures in the USA and his understanding of Savić's antipathies to Havliček, who is also as good expert in reactor technology as Milorad Ristić later director of Vinča) or anyone else in Vinča, so it is not nice that Savić is pushing Havliček out from the IJS. Peterlin could even be a bit witty: "I am extremely pleased that with my stay in America I missed numerous conferences on programs that have always been distinguished for their hecitivity like budget deals."

By 23 December 1955 after returning from the United States by boat Peterlin planned to visit Marjan Senegačnik (1928-2002) in Paris where Senegačnik defended his Ph.D. entitled *A Study on the Isotope Effects in the Reduction of Carbon Dioxide by Zinc* (*Etude des effets isotopiques dans la réduction du gaz carbonique par le zinc*) in University of Paris in 1957. Peterlin also wished to visit Moljk in Glasgow and others, then he wanted to afford some skiing, so in mid-January he would be in office again. Peterlin emphasized that

³³³¹ GDP.

researchers of the IJS will find enough domestic uranium for all needs of Ljubljana, which soon turned out to be doubtful. During Peterlin's absence, Kosta and Dekleva attended the First International Conference on Peaceful Uses of Nuclear Energy in Geneva on 8. 8. 1955-20. 8. 1955. There, Kosta asked for a possible visit to the IJS Workers at Harwell. The answer was not completely negative, but the Brits suggested that people should be first sent to Oxford, Liverpool and Birmingham.

The heads of IJS laboratories wrote reports for June 1955, which Peterlin's sister Marja Lapajne then sent to Peterlin in the United States. Among them was Edvard Cilenšel.–He worked at the IJS from 1950 until his departure to Iskra in 1965, described in the report to Peterlin for June 1955 the work of the vacuum laboratory A1. On the electrostatic accelerator, the leakage of all vacuum elements with McLeod was measured, and a rectifier for the Penning's Vacuum-Meter³³³² was placed on the panel of the radiofrequency ion source. They developed a power supply for the Leybold ionization triode Telefunken IM 5, in part, they had the prototype ionization triodes IM 5 and 5 Penning's vacuum gauges with the M19³³³³ connector cone. In a report for July 1955, Cilenšek complained about the liquid air imported from Ruše, because 15 liters of poorly insulated vessels were sometimes emptied because of the evaporation on their way to the IJS. At home, a 60 l/s diffusion pump was built, and a slightly worse Edwards' pump and Knudsen's vacuum gauge was used.³³³⁴ In September 1955, in Cilenšek's networks, the flow protection was designed and tested to stop the diffusion pump from burning in the event of a power failure and to produce an ionization triode. In October, the maximum suction speed of 300 l/s of the diffusion pump with a receiver of a volume 500 l was measured for the Institute Elektrozeve. It was achieved at 1200 W using klofen in a vacuum of 10^{-4} mm Hg.³³³⁵ Klofen was later mostly used in the pharmacy. Peter Zazula built a vacuum calibration device in a laboratory for mass spectroscopy led by Janez

Dekleva,³³³⁶ and at the beginning of October 1955, he worked with engineer Alojz Paulin.³³³⁷

On June 28, 1955, Peterlin wrote from Detroit a letter that arrived at the IJS on July 8, 1955.³³³⁸ He proposed that they sent one of the new chemists or physicists to a nuclear engineering course at the University of New York. Until then, that branch was developed only by Zagreb Czech F.I. Havliček. Now Peterlin wished in his place above all Osredkar, and he was a little angry because Osredkar has postponed his departure to New York for personal benefits. Havliček's work consistently challenged disputes with researchers in Vinča. On 6 July 1955, Osredkar wrote to Peterlin that he refused to go to New York University because of his family, which was too often separated from him because of his previous work, as Peterlin's sister Marja reported to Peterlin's American address with funny remarks about the harsh Osredkar nervousness in those days.

When the issue of daily subscriptions was settled on 29. 7. 1955, Osredkar announced that he would go to New York. On August 23, 1955 Peterlin wrote a recommendation for him. Osredkar went to Belgrade to meet Secretary General Slobodan Nakićenović and his assistant the Dalmatian Ljuba Barbarić. Osredkar joined the Professor Richard Montgomery Stephenson (* 1917) at the College of Engineering of New York University in the USA with a \$ 273 grant per month, which was half as much as the usual sum. Their joint publication was a research of low-power, high-thermal-flux experimental nuclear reactor.³³³⁹

Osredkar went to Belgrade to Secretary General of the ZKNE (Federal Nuclear Energy Commission) Slobodan Nakićenović and then to New York, so that Kajfež could have moved to his room on September 26, 1955. After a long reflection, Osredkar realized that he would need a doctorate for further work, so he would move to the US for two years, where his son the physicist Radko Osredkar also went to school. In fact, Milan Osredkar stayed in the United States only until December 1956.

³³³² F. M. Penning at Philips in the year 1937 with its betterings after the war.

³³³³ Letter of Marja Lapajne mailed to her brother Peterlin in USA on 9. 7. 1955, received on 13. 7. 1955 (GDP).

³³³⁴ Letter of Marja Lapajne mailed to her brother Peterlin in USA on 30. 7. 1955 (GDP).

³³³⁵ Letter of Marja Lapajne mailed to her brother Peterlin in USA on 5. 11. 1955, page 3 (GDP).

³³³⁶ Janez Dekleva, letter to Peterlin signed on 30. 7. 1955 (GDP).

³³³⁷ Karel Kajfež, letter to Peterlin signed on 10. 10. 1955, received 13. 10. 1955 (GDP).

³³³⁸ Archive IJS in Podgorica, legacy inventory M. Osredkar, mailed by Janez Stepišnik on 31. 1. 2006.

³³³⁹ *Osredkar, Stephenson, 1957*,: 210-214.

Peterlin often wrote to Kajfež and other associates from the USA. On 20 September 1955 he visited the University of Chicago.³³⁴⁰ There he examined the Institute for Nuclear Studies, which is "a huge thing for three Ljubljana, have a 450 MeV synchrotron for protons, a 100 MeV betatron, 3 cathode ray tube electronics, mass spectrometers and all other devices. I only saw an insignificant piece of the whole huge apparatus. The next day, at noon, dr. William A. Chupka (1923 Pittston-2007) drove me to Argonne, 40 km away, where unfortunately I only had very little time to see only the mass spectrometry and the school of reactor engineering."³³⁴¹ A few months later Peterlin sent Čopič to the Argonne National Laboratory in Chicago. On February 14, 1956, Pičman went to Copenhagen for a one-year study of nuclear theoretical physics at Bohr's networks, where, prior to him, Črt Zupančič worked on Van de Graaff accelerator since December 1952. Lovro Pičman (* 1929 Ljubljana) always kept a great respect to Bohr, Teller and other Manhattan fellows as he told the author of this lines.

Peterlin went to Israel for fifteen days, of which he spent five days in Turkey. On June 29, 1956, Jamnik was given a visa to travel to the Netherlands, Switzerland, Germany and Austria. On July 12, 1956, the IJS imported equipment with money from Hungarian reparations.

On 15 September 1956, a passport was raised on the Swedish consulate for the journey of Uči and her fiancée Milan Osredkar. On 16 September 1956, the IJS reported to the Federal Nuclear Energy Commission about travels abroad after 1 July 1956. On 3 August 1956 and 4 August 1956, Peterlin purchased the ultracentrifuge for the separation of isotopes or polymers at high peripheral speeds.

The senior referent Osredkar has been studying reactor physics in New York since September 1955 under supervision of the professor Stephenson. Janez's sister, the assistant Alenka Dekleva (1929 Ljubljana; † 1995), later married Likar, attended the electron microscopy congress in Stockholm on September 18, 1956 and visited Saclay University in Paris. Alenka research at Marinković's lab between 1954-1960, and after Peterlin's departure and difficulties in studying macromolecules, she

took over the professorship at the Faculty of Medicine in Ljubljana.

Jamnik was in Amsterdam at a conference on nuclear reactions in July for 10 days. Čopič was in the United States at the School of Reactor Physics. In December 1956, Senegačnik worked on isotropic effects in Saclay in Paris. The IJS fleet was already complete for success, including a 10-year-old Ford, which Peterlin used as a former Kidrič's gift. The car was driven by Vinko Ravnikar, who, after Peterlin's departure from the IJS, had to find another job.

On 15 November 1956, IJS sent engineer Janez Kristan for one-year study in the USA after Kristan graduated in Vinko Kramaršič's class in Ljubljana in 1952. Kristan worked at the IJS, especially in Podgorica nuclear reactor between 1953-1977, and then went to the national health inspectorate. Čopič was in the United States in the middle of his affairs with countess' plane from 3 July 1956 to 30 September 1956. On 13 and 14 January 1956, the IJS representatives met with scientists. The JNA has decided to use the services of the existing three Yugoslav nuclear energy-dedicated institutes and will not build their own JNA nuclear institute. On 9 October 1956, Peterlin wrote to Nakićenović about Knop's proposal for the gradual abandonment of the heavy water department, which only became a financial burden since importation became possible. Savić agreed with the proposal. As the secretary of the newly-established CK ZKJ at the IJS, biochemist Zagreb PhD student Drago Lebez (1922 Borovnica-2015) already published in the final report for the year 1956 two pages of glorifying of IJS importance on November 29th, 1956. It was a part of his speech at the celebration at the institute. It was followed by 30 pages of Peterlin's report, half the page of D. Sušnik's library report, which at that time had 4536 books and 105 magazines, etc. Knop was still working at the heavy water department, while Havliček decided to concentrate uranium on the decision of the IJS Council of 4 February 1956. With this decision, they stopped the development of the ion source with heated cathode for the neutron generator and systematic measurements of the neutron spectrum Ra-Be source and neutron diffusion calculations within the homogeneous reactor program.

³³⁴⁰ GDP.

³³⁴¹ Peterlin's letter to his wife 24. 9. 1955 (GDP).

The IJS Council commissioned work on uranium concentration by the distillation method, E.W. Becker of Marburg-Carl Gustaf Patrik de Laval nozzles and diffusion membranes. They developed the technique of enrichment uranium measurements at distillation using an ionization cell. The liquid UF₆ was produced until 1 April 1956, and then again from October 1956 onwards. On 12 June 1956, Havliček presented the expected separation effect at the lecture and published in Reports 24/25. 9. 1956. Work with mass up to half a kilogram of UF₆ was possible, while only 50-60 g for fractional distillation had previously been used. They had Becker-Laval nozzle, but the IJS did not have enough sensitive measurement devices. The microtron of Paulin was nearly completed; the vacuum chamber and microwave elements were designed from the output of magnetron to the accelerator resonator of the pulse generator.

Marinković's co-workers in the material testing laboratory were using Carl Zeiss' electron microscope, purchased at the Laboratory for Investigating Material of the IJS in October 1954. They examined ten domestic and three foreign PVC samples. The molecular masses of polymers were determined. Alenka Dekleva studied erythrocytes for her research of virus cultures at Marinković's lab. With an electron microscope they also filmed for external subscribers from Geological Institute's samples of chalk from the lakes and eighty zinc oxide samples from Cinkarna Celje. Soon, Boris Navinšek joined the electron microscopy section in 1957. In Marinković group, the scattering of X-rays was also studied.

On 5 March 1956, Peterlin lectured about his scientific and pedagogical work in the Ljubljana club of Scientific and Cultural Workers in Ljubljana, and he talked about the IJS for the Radio Slovenia on the day of the republic on 29 November 1956. On 21 October 1956, Peterlin wrote about Science in Sweden for Human Rights (Ljudska pravica) journal of Ljubljana.

Between 10 and 26 October 1956, the IJS organized a second course of radioactivity with lectures of Č. Zupančič, Kosta, Lebez, the mathematician Anton Vakselj's (* 1899; † 1987) son Marko Vakselj (1932—2017) and others, but without Kuščer or Moljk. The third course followed from 19. 11. 1956 to 28. 11. 1956.

On 10. 1. 1957, Peterlin wrote to Nakićenović an angry letter. Nakićenović told him by telephone that ZKNE did not oppose Peterlin's departure to Moscow at the invitation of the academy of science there. However, the Nuclear Energy Commission argued that macromolecules do not fall within its scope. Of course, Peterlin was very angry because his macromolecules' research was at Hamletian position to be or not to be. In 1956 he got the IJS task to study Teflon as the fluorocarbon macromolecules. In 1955, Vinča wanted to work with Teflon, but the IJS experts were more experienced with both macromolecules and fluorine. Thus, the IJS received these highly macromolecular orders according to the budget for the years 1955 and 1956. In a conversation with Savić after returning from Israel, Peterlin got the feeling that Savić had to explore many impacts of the radiation on the macromolecules which they were dealing with at Harwell. Therefore, Peterlin sarcastically asked the Commission for "an authentic explanation of where macromolecules are starting and whether Teflon and polyelectrolytes are involved, i.e., are the ion exchangers under the notion of macromolecule or not." It was clearly a joke because Peterlin knew much more about the macromolecules compared to the folks he was asking about them.

On 22 January 1957, Dr. Bahittin Baysal (1922 Kırşehir-2017) from the Department of Physical Chemistry Fen of the Faculty of the University of Ankara visited the IJS. Peterlin organized his visit during his journey to Israel and Turkey. Peterlin, as a member of ZKNE, attended conferences in Egypt and Greece in 1957, and he joined the conferences in India in 1958.

On 12. 3. 1955, Peterlin dismissed Moljk from the IJS based on Moljk's letter with validity on 28 February 1955. That conflict was a basis of the later Moljk's revenge. Nevertheless, on 13 November 1956, with the validity date of 1 January 1956, Moljk concluded a part-time contract with the IJS as a leader and organizer group (laboratory) for N-3 nuclear spectroscopy. In July, August and September 1957 and in 1958, Moljk did not receive salaries due to his work in England and Scotland.

Moljk began as a physicist before the war after graduating from mathematics, just like Kuščer and Peterlin. Moljk received his doctorate in 1956 in

Peterlin's class when Kuščer and Dominko were also in the exam committee. The topic of Moljk's 209-page dissertation, mostly done at the Glasgow University Institute, was Beta spectroscopy in the range of smaller energies. The defense was on the first floor of an old university in a room that has a balcony facing the Revolution (Congress) Square. Dominko did not ask questions, but Kuščer asked the question about thermal efficiency. Peterlin asked three questions, but the candidate Moljk could not answer the third on the spectrum of beta rays. Peterlin then mentioned that this area is not exactly Moljk's favorite.

All the audience expected that Moljk failed his exam as Moljk's performance was very bad. There was a longer interruption due to the meeting of the commission, and then the rapporteur dr. Ivan Vidav came to inform that candidate Moljk successfully passed the doctoral examination. Later, the students were murmuring that Moljk had a high connection, although he was not in the communist party, as everybody felt that Moljk did not pass his exam adequately. Moljk's promotion was followed in the presence of the entire examining committee only one week after the defence, while other doctoral candidates waited several months or even a year for their promotions.

Unlike Plemelj, Peterlin soon got influential opponents in his own house, as he did not have the right support at the university for the development of his institute. He joined the UDBA but not the communist party which proved to be fatal as he was not famous enough to play Heisenberg's WW2 quiet oppositions. At the beginning of 1959, the new institute had 300 employees. In the third year, Peterlin lectured on electromagnetic field with relativity theory and optics for the seventeenth year, and for the fourth year students he explained quantum and nuclear theory (1943-1959). After his departure, the lecture of the electromagnetic field was taken over by Blinc.

30.1.4.7 Replacement

At the end of the year 1957 the Institute Vinča near Beograd got from Soviet Union the first two Yugoslav heterogeneous nuclear reactors working with natural or enriched uranium and heavy water. In addition to this, Kidrič's successor the minister Vukmanović-Tempo, besides the experimental reactor received from the Soviets' major target

nuclear reactor designed for China, which produced annually one or even two kilos of plutonium. Tempo got the experimental reactor, which was provided for usual Soviet European satellite states, but also the bigger one made for China.³³⁴²

The ZKNE gathered to approve Tempo's deal and Supek was certainly heavily against it. The ZKNE met to formally confirm Tempo's purchase several years after Tempo's brother met his last hour in Slovenia as a quisling on the run.

Despite of the threats and the anger of Beograd politicians, Supek with Peterlin's help organized the meeting of IJS, Zagreb Institute Ruđer Bošković, and Institute Boris Kidrič of Vinča as three centers financed by ZKNE. At the meeting, they recommended that the government withdraw from work on the nuclear power plant, which Supek subsequently established as a conclusion fit for all non-aligned countries in Accra (Ghana). Even Savić agreed with the conclusions of the meeting in Ljubljana, which was an exceptional turning point in Savić's chairing in Vinča. In Ljubljana meeting there was also a secretary of the ZKNE who happened to be the unfinished student of technique. Of course, he did not confirm the conclusions of the meeting while after the meeting he threatened Supek with consequences. Savić's support of the results of Ljubljana meeting probably worsened his position in Vinča.

Supek later described the event in his dramatized fiction work. The Minister of defense Gošnjak secretly told Supek that even army has no interest for a Yugoslavian nuclear bomb but Kardelj wanted it. Supek and Peterlin usually planned their joint Beograd budgeted strategy during their journey on the train. Ivan Supek's brother Rudi was also a distinguished literati and Tito guarded their Zagreb oppositional headquarters from total damages as a secret Croatian nationalist.

The politician soon made a revenge. Peterlin, Supek, and Savić were dismissed after the disastrous accident at Vinča on October 15, 1958 with six workers injured. Peterlin, Supek and Savić's dismissal occurred after the accident in Vinča in Beograd suburb on 15 October 1958, which hit six workers just after Tito's huge

³³⁴² Peterlin, *Fizika* 1957, 11; Pravić, 1994, 34.

celebration festival by putting Vinča reactor in operation half of a year earlier on 17. 5. 1958.

The reactor under the chief of project and leader of the group Dragoslav D. Popović (1926 Skopje-2013) had no work permit as the security was far from being adequate. Dragoslav Popović was dismissed immediately after the accident and lectured in the Electrotechnical faculty of Beograd after 1959. His main collaborators in Vinča were the engineer Nenad M. Raišić, Stevan M. Takač with diploma in engineering physics and Hranislav Marković also with diploma in engineering physics. S. Dedijer's replacement in 1954 Vojko Pavičić as the director IBK was also fired after the accident in Vinča in 1958.

Savič noted that Dragoslav Popović's inexperienced student, in their desires for quick measurements, maybe pulled out the control rods from a small learning reactor, as the student was compelled to collect data for his diploma thesis as Savič narrated, or the rods were removed most of the time anyway as Hajduković remembered.

The students worked in Vinča for three months before the disaster. The entrance was strictly controlled as the legend tells that you were forced even to give the number of your shoes to the doorkeeper, but the reactor was not controlled and even the alarm devices were disabled not to disturb the employees. During the accident the radiation was so heavy that the Geiger counters were "damped (suffocated)" and stopped to react. In Savič's version, the young postgraduate student wanted to get the experimental results as quickly as possible and pulled out the control sticks of the little school reactor, where he worked on his dissertation. The radiation was so great that the Geiger counters were overflowed, and they didn't count at all.

The student got aware of the danger only after he smelled the ozone produced at the air by radiation; he released the rods at their proper places quickly, but he already got the mortal amount of radiation. The excellent student with Matura from (Titovo) Užice Života Vranić was aware of the danger only when he smelled the ozone that was generated by radiation in the air; he dropped the rods back into the reactor and bravely stopped the reactor to prevent further damages, but he had already received too much radiation. By Hajduković's

narration Roksanda Dangubić (Rosa) stopped the reaction with her hand by putting cadmium rods into the reactor as no automatic worked.

The engineers were in the meeting but soon one of them entered and ordered all folks out of the building while Hajduković told everybody in Vinča by phone about the disaster.

After their huge radiation doses, six people were immediately taken to Paris for treatment, but the student of physics Života Vranić (Žika, 1934 Mojsinje by Čačak-1958 Paris) died.

The student Roksanda Dangubić (Rosa) who few years later became a mother of healthy daughter despite her unpromising family name, the student Radojko Maksić (* 28th October 1933 Popova by Jastrepac in Serbia), Draško Grujić, Stjepo Hajduković (Stijepo) who posthumously published his accusation report Svedok događaja in Bilten Instituta za nuklearne nauke Vinča no 4/97, in 1997 against P. Savič's comment published in the Beograd based leading journal NIN no 1838 on 23. 3. 1986. They and their less radiated senior Živorad Bogojević recovered in the Parisian hands of Georges Mathé (9 July 1922 – 15 October 2010) by the first ever bone marrow transplants. The graduate works of dying Života Vranić and Radojko Maksić was noted as finished during their six months of Parisian treatment, while Roksanda Dangubić (Rosa), Draško Grujić, and Stjepo (Stjepko) Hajduković had to finish their work for diplomas with their newly advanced fellowships.

Most of the victims of the accident and even their children continued to work in nuclear physics after their recovery while Hajduković especially excelled in radiation related medical studies in Vinča Institute renamed to Boris Kidrič and in Federal bureau of measures and precious metals in Belgrade in Yugoslavia. Dr. Maksić worked under Ranković in state department of nuclear energy ZKNE for next forty decades including the elaborating of Krško nuclear power plant. Maksić survived all the others in 2015, while besides him only Roksanda Dangubić (Rosa) was still alive in 2011.

The big boss Leka Ranković personally told Nakićenović to keep strict confidence. Nakićenović told Hajduković to pass to other victims to be silent about the accident for at last

next three decades. Although dr. Pavle Savić was not directly guilty, Peterlin nevertheless blamed him.

It was the first major after-war publicly acknowledged nuclear accident. The Director Dr. Pavle Savić was not directly involved at the disaster, but Peterlin eventually put forward his responsibility.³³⁴³ Savić was former Curie's collaborator, Tito's host during Tito's visits in Paris and Tito's code-maker during WW2. Savić also published few nice cosmological books.

A month after the accident, on 21 November 1958, at 8:30, the humiliating disaster was discussed by Ranković's Federal Nuclear Energy Commission. A month later, on November 21, 1958 at 8:30 Ranković's Federal Commission for Nuclear Energy discussed the accident and the commission member Nakićenović mailed the meeting protocol to Kraigher at Ljubljana as "top secret". Nakićenović reported strictly confidential to Boris Kraigher (Janez, 1914 Sveta Trojica in Slovenske gorice; † 1967 Sremska) the dropout student of civil engineering in Ljubljana in 1932 and 1934 and now Chairman of the Executive Council of the People's Assembly of Slovenia. The leading politicians and scientists like Tempo, Savić, the minister of defense Gošnjak, Milentije Popović (1913 Crna Trava in Serbia-1971) who graduated at Beograd technical faculty and Milan Radulović were also present. In point 2, they discussed the accident at the "zero" reactor in Vinča and concluded that the workers should remain on treatment in Paris, and the Yugoslav Commission with Barbarić and Lebez should consider the consequences among their members. Savić submitted the conclusions of the meeting of the CK ZKJ Vinča, but Ranković opposed his reading, since such a small committee would not have enough power to solve the sensitive problem. Savić put at the limelight the protocol of the meeting of CK ZKJ of Vinča, but Ranković did not allow him to read it, because he thought that such a small group of the communist was unable to handle such a delicate problem. He preferred to change the subject and discussed the relations between the leading scientists and the president of the IJS scientific board (Peterlin) suggesting that Kraigher will make a full report for Federal Commission for Nuclear Energy soon. Ranković was more inclined

to change the topic to the relations between leading staff and the President of the Scientific Council of the IJS, on which Kraigher will soon inform the Federal Nuclear Energy Commission.

The disaster at Vinča may have somewhat postponed Ranković's action to replace Peterlin, as it was a shameful severe blow to the ability of Yugoslav experts to build A-bomb. In any case, Ranković saw in Peterlin (and Supek) the obstacles on the way to the A-bomb and did not allow his victims to escape. The Vinča disaster postponed the dismissal of in the decade after his Peterlin and others. Few days after the disaster in Vinča, Kraigher forced Peterlin to resign.³³⁴⁴ All three directors of the nuclear institutes were replaced by obedient managers of the ZKNE, who were supposed to introduce discipline: Zagreb got Tomo Bosanac (1918 Bjelovar-2003 Zagreb), and Vinča got the engineer Vojislav Babić who headed Vinča in 1959-1961. All three directors of Nuclear Institutes were replaced by the obedient managers of ZKNE, to force the discipline. The new directors of the institutes should be engineers: in Vinča the Secretary of the Scientific Council of Serbia engineer Vojislav Babić, in Rudjer Bošković they got the engineer Tomo Bosanac, and they also agreed with the Kraigher's changes in the IJS.

Ranković proposed that the number of members of the Federal Nuclear Energy Commission should be reduced from 25 to 9 or 11, while in addition to officials two or three scientists would be more effective because of those changes: this was, of course, the exclusion of Peterlin and Supek, although Supek was installed by Tito and was not easily removed.

The collapse of the A-bomb project with huge investments slowly contributed to Ranković's fall. As President of the Scientific Council in Vinča, Savić was appointed as the President of the Council of the Institute. In reformed the federal bureaucracy, Savić no longer represented real power in Vinča, Rudjer Bošković Institute in Zagreb, or the IJS. Savić later lectured at the chair of Physical Chemistry of the Natural Science-mathematical Faculty and never put his foot at Vinča again after his second mandate as the director in Vinča.³³⁴⁵ Savić continued to work at

³³⁴³ Peterlin's letter to Kraigher, August 6, 1960 (GDP); Zupančič, 2000, 80.

³³⁴⁴ Zupančič, 2007, 13.

³³⁴⁵ Pravdić, 1995, 35.

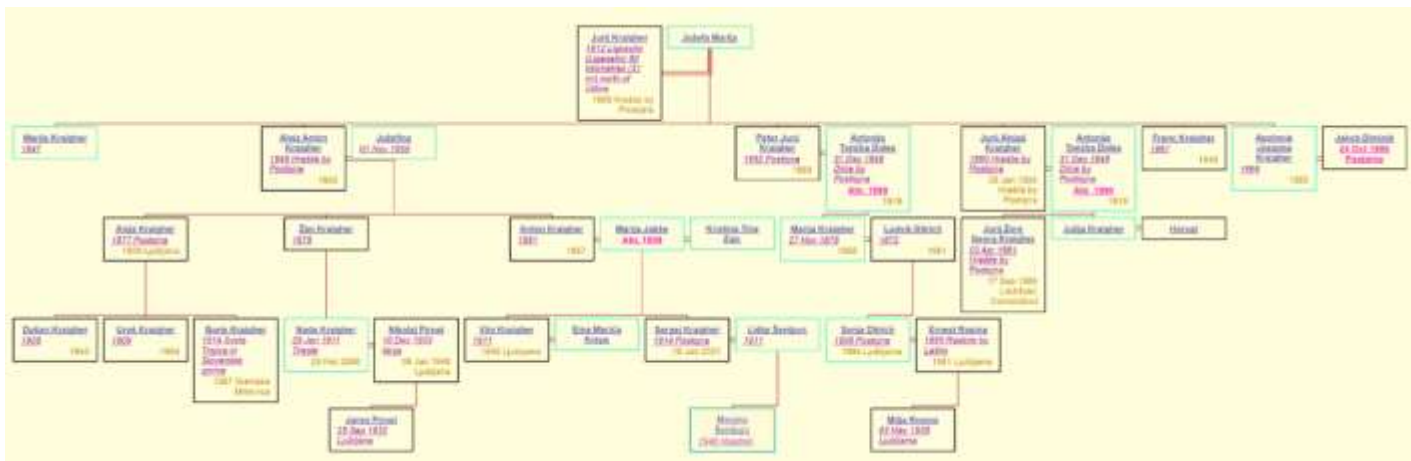

Figure 30-7: Ancestors of the IJS boss Boris Kraigher

the Department of Physical Chemistry at the Faculty of Natural Sciences and Mathematics.

In the winter of early 1959, Savić had to resign in Vinča, while Peterlin's friend Ivan Supek left the leading position at the Rudjer Bošković Institute in Zagreb, and Peterlin did the same at the IJS. Supek later returned to his position, Savić no longer headed Vinča, and Peterlin was replaced by Moljk. So, after the meeting of the IJS Council on January 8, 1959, when Kraigher was present, Peterlin was forced to confirm the resignation from his duties of the president of the Scientific Council with the date of validity 31. 12. 1958. He remained only an university professor.

Peterlin summoned a speech in which he wanted to propose Moljk to his successor. But for those circumstances, he did not have a written speech, as he noted at his draft. Moljk was not only Peterlin's successor, but, even more surprisingly, the successor to Savić as the president of the expert council of the ZKNE. He was in this position in 1967, when he published a discussion with his colleagues in Belgrade on the future work on nuclear energy, especially on reactors. Supek remained a member of ZKNE (SAKNE), since Ranković could not withdraw Supek from there without Tito's consent; there to some extent Supek succeeded in opposing the construction of a Yugoslav reactor based on the example of Chernobyl, especially with Milentije Popović, Avdo Humo and Gošnjak, who whispered to Supek during the pause of the meeting "the army has no interest in the A-bomb". Supek was also a member of the CERN Council and addressed the company

"Rade Končar" that produced a large magnet for the accelerator in Geneva.

However, Ranković's ZKNE later removed Yugoslavians from CERN, certainly in fear of the Western influences. In November 1958, Peterlin was compelled to apply for dismissal, he was forced to ask for replacement. His replacement was dated December 30, 1958, and Nakićenović signed it with Ranković's approval.³³⁴⁶ Nakićenović signed Peterlin's resignation with Ranković's authorization.

On 3 December 1958, Nakićenović reported to Ranković that Peterlin is currently in Belgrade at the session meeting of the Scientific Council-Board of the FNRJ, and in the next two days he will apply from Ljubljana for a specialization abroad, during which he will no longer be president of the IJS Scientific Council. Peterlin left the post of the president of the Scientific Board of IJS. Nakićenović proposed Moljk, who was active in the DMFA since 1952, and Šinkovec, who worked with the partisans only since 1943, and for the reserve Nakićenović had even more faithful Pečnikar. On November 4, 1958 Peterlin really asked ZKNE for the stipend for his work abroad. He planned to work for four months at Mathematical Institute of Munich and at the Polymer Institute of Mainz. Next, Peterlin wished to research during eight months at Wayne University in Detroit, where he had already agreed on a visit to solve the diffusion equation of the motion of polymers molecules in the laminar flow

³³⁴⁶ GDP; personal note of Tanja Peterlin-Neumaier, February 2, 2007.

at the Institute of Computer Calculations. used to be at Wayne University of Detroit already at 1955. Peterlin wished to arrange his future work to solve the diffusion equation of polymer molecule moving at laminar flow. Of course, he was particularly interested in the amount of the scholarship, indicating that in 1951 Emil Theodor Kocher (1841 Bern-1917) Institute at Medical faculty of University in Bern paid him 1200 Swiss Francs per month for a salary of a university professor, and Mirjan Gruden, a university professor, received \$ 600 per month from Vinča institute for his work in the US.

Kolman Hodošček was responsible for security at the IJS, but the political characteristics of Čopič issued on 24 January 1953 and notes on other workers were signed by the director K. Kajfež together with Tomaž Vos, who relatively illegible signed himself. Hodošček, together with a mechanical engineer Ciril Pisanski, Moljk, Kuščer and others belonged to the new leadership of the IJS, photographed in 1959 in a group including Ranković. Pisanski worked at the IJS, and immediately assumed the leadership position between 1959 and 1969. He graduated in 1953 with the work "To create an additional mechanism for sharpening the pointed arrows with a universal cutter grinding machine for Reinecker type URF 7a gear wheels, the maximum diameter of the gearing 3000 mm" on 52 pages. He occasionally wrote about the mechanical problems of toothed machines for another half a decade. At the IJS, he focused entirely on researching reactors and received his doctorate in 1963 with the dissertation Structural and technological problems related to the safety of the Magnox nuclear power plants on 30 pages. As a member of the elite, he was also an important hunting association official and a court special engineer which helped a lot the whereabouts of his son Tomaž Pisanski.

In the new Scientific Council after Peterlin's removal, the physicists were Kladnik, Kuščer and Č. Zupančič, and among the outer members, the captain of the battleship Stevo Žutić. The members appointed to the Management Board were among others Č. Zupančič, Osredkar, Kosta, Kuščer, Moljk, Pečnikar, Lebez, dr. Janez Milčinski as the forensic medicine expert, and head of the semiconductors laboratory at the Institute for electro-connections the engineer Matija Seliger (21. 1. 1925 Vrhnika). Seliger participated in the

NOV since 1942, and he became a member of the KPJ in 1944. However, he was expelled because of the failure at battlefield action. In 1953 he graduated and was trained abroad. He was again accepted in the ZKJ in 1955. Matija Seliger was a father of the physicist Janez Seliger (* 1949).

In the decade after his dismissal, in journal *Proteus* Peterlin reported on genetics of Zalokar who found space in the USA instead of his natural Slovenian home which Peterlin regretted as his own destiny. Zalokar got his Ph.D. in *Laboratoire de zoologie et anatomie comparée* with a thesis *Contribution à l'étude de la régénération du cristallin chez le triton* printed in Geneva in the middle of the war in 1944. Marko Zalokar (July 14, 1918 Ljubljana-September 4, 2012 Seattle, WA.) published several articles under Peterlin's editorship in *Proteus* from 1936 to 1947. Zalokar and brothers Ivan Kuščer and Dušan Kuščer (1920-2012) researched undersea flora and fauna in Rača 75 km southeast of Rijeka south of Senj south of Sveti Juraj (Jurjevo) under Velebit which Peterlin praised. Peterlin was never fully aware that Ivan Kuščer was Peterlin's chief antagonist in Ljubljana as both loved to write in their good Slovenian language, both loved the mountaineering and admired all sorts of natural phenomena. Therefore, Peterlin always considered Moljk as his devil destiny.

Zalokar's first love was the botany but in USA he turned to genetics which later produced CRISPR/Cas genome editing in 2012 and enabled the myriads of Chinese human genes editing in 2018. After WW2 Hadži invited Zalokar to Ljubljana university, but Zalokar declined from personal reasons certainly involved in politics.

Zalokar worked at Department of Zoology, University of Washington, Seattle, Washington USA in 1953-1955, and at National Institute of Arthritis and Metabolic Diseases, National Institutes of Health, Bethesda, Maryland, USA in 1955, where later R. Podgornik researched.

In 1959, Zalokar worked in for Yale University at New Haven, Connecticut. In 1968-1969 he was in Pasadena in California, and in 1976-1984 in Centre de Génétique Moléculaire de C.N.R.S., 91190 Gif sur Yvette, France, in 1984 also in Station zoologique of Université P. et M. Curie, Paris VI.

Peterlin praised the penetrating Kidrič, as well as Osredkar and Stephenson, who was supposed to recalculate the operation of the Oak Ridge reactor. Peterlin especially emphasized the "poorly grounded Yugoslav speculation for the A-bomb" that wasted a fortune and even more for fantastic nuclear technology and mining. He did not specifically mention Ranković, but Peterlin sarcastically explained that with the escape of Slovenian brains in the United States, where the folks soon forget Slovenian language, there is nothing new in domestic fields. "The hungry crow is feeding the satiated one".

Although Pavle Savić was not directly guilty,³³⁴⁷ he was accused as the president of the scientific council in Vinča, because the post of president of the institute's council after the reforms was no longer a real power in Vinča, at the Rudjer Bošković Institute in Zagreb or at the IJS. In 1959 Savić had to resign, while at the same time Peterlin's friend Ivan Supek at the Rudjer Bošković Institute in Zagreb, and Peterlin at the IJS also resigned. However, Peterlin's friend Supek and his opponent Savić soon returned to their posts, while Peterlin was only a university professor after 8 January 1959.

Unaware of those deep Slovenian mishmashes, Stephenson visited Ljubljana at least twice including his visits to the IJS. On July 31, 1971, Moljk denied the allegations published by Peterlin in the previous issues of the same newspaper on July 17, 1971 of the journal *Delo* in *Sobotna Priloga* as part of a series of interviews of the poet-journalist Dušan Željeznov (1927 Ljubljana-1995) with the creators of the Yugoslav atomic era at the dawn of the Croatian Maspok. At the same time, Moljk complained that someone (Peterlin) had crossed out Moljk's name with a shower from the preface to Peterlin's book of radioactivity. Moljk stated that in June 1958 Kraigher, as President of the Executive Council of Slovenia and an official (Chairman of the Board of Directors), called Moljk at the IJS and told him that a five-member delegation from the IJS visited him and asked Kraigher to replace the management of Peterlin. The delegation or commission was established at the end of 1957, but its composition under the leadership of Osredkar was changing. Moljk claimed that he did not know the names of all five,

³³⁴⁷ Peterlin, letter to Kraigher signed on 6. 8. 1960, appendix, page 4a (GDP).

although he knew them all too well from other sources. Since the fall of 1953 with smaller intervals, Moljk has been measuring beta spectroscopy at the Physics Institute of Glasgow University and returned to the Yugoslavia during the holidays in 1958. In December 1958, Kraigher called Moljk again and told him that, in view of Peterlin's request, Moljk would have to replace Peterlin, but Moljk must provide Peterlin with smooth work with the macromolecules at the IJS. Moljk hesitated about his new functions in the IJS, as he wanted to continue his measurements in Glasgow, and he was also preparing a book on the measurement of low radioactivity entitled *The Low Radioactivity Measurements* for the London Butterworths publishing house, for which the University had already given him a summer vacation in 1959. On 15. 12. 1958, Moljk indeed wrote to Kraigher that he had too much work at the university, while Kuščer just sent out the first part of their joint textbook, and Moljk was preparing two more papers about his measurements in Glasgow. Moljk considered that the new president of the Scientific Council of the IJS would have a better position if he had not been in the same game with Peterlin before, as was the case with Šinkovec.

On 10 February 1959, based on his talk with the new IJS director Šinkovec, Peterlin proposed his part-time job in measuring nuclear magnetic resonance on organic crystals in IJS. The work should cover the temperature effects and different radiation effects on NMR spectra of those substances. At his typescript Peterlin stated that he could describe the details later, his work can be further explained. After January 1, 1959 he should work eighteen hours per week, that is, three hours per day.

Under Peterlin's writing the other hand, probably Šinkovec's, wrote: »Demand the details, data: How many people« Peterlin didn't request any extra budget for that year.³³⁴⁸ There it turned out that Peterlin intended to employ Blinc, Adrijan Levstik (* 1939 Brežice), Krašovec, the lady Marjana Oblak, Marinković and Peter Venturini in his working group. As for the funds, Peterlin considered that "this year he needs no money" because he did not plan to buy new tools. He allocated his works at the rooms 117 and 110 at the IJS. On March 5, 1959, Peterlin signed the contract

³³⁴⁸ Peterlin's personal map, Archive IJS at Podgorica.

with IJS for his work with NMR of organic crystals for the analysis of spectrum dependency on temperature and nuclear radiations. The plan was not put into action as Peterlin slowly decided to move abroad.³³⁴⁹

Dr. Franc Krašovec worked at the IJS between 1953 and 1968, then worked with LEK of Sandoz corporation. Igor Levstek published an article in 1960 with Peterlin. In 1960 and 1961, he published NMR research with Blinc. Apparently, Peterlin had enough young people willing to explore the NMR, but his star at the IJS was orbiting into Moljk's shadow. Blinc was eventually too clever and well informed to put his scientific destiny on Peterlin's disposal in Ljubljana in those times of Peterlin's disgrace.

Peterlin went abroad after the 5th of March 1959, when he concluded a one-year contract for the honorary research of organic crystals with nuclear magnetic resonance with the new director of the IJS, Lucijan Šinkovec. On 20 March 1959 Peterlin's proposal was adopted by the Vice-Dean of the Ljubljana Faculty of Natural Sciences Dušan Hadži, based on a meeting of the Management Board on 11 March 1959, permitting Peterlin's part-time employment at the IJS with a basic salary of 59,800 dinars, in addition to 29,800 dinars paid for his position of full professor and the adds of the Institute 6,200 dinars per month. On 5 March 1959, Peterlin signed a one-year contract with the new director of the IJS Lucijan Šinkovec for the honorary research of organic crystals with nuclear magnetic resonance. The Inner Carniolan engineer Lucijan Šinkovec from the poor official family was forced to earn his bread during his secondary and high schooling by his additional teaching classmates and drawing. His father Jože was killed in the First World War, while the parents of his mother of Frančiška Mayer lived in Hungary. In this sense, there were suspicious Šinkovec's statements about Cominform (Informbiro) quarrels of 1948, which would be uninteresting for average job, but not for a position of director, as a Škofja Loka resident Stane Bernik from the People's Committee of Kranj wrote in Šinkovec's characteristic for the IS of Slovenia.

In 1935, Šinkovec graduated from the Faculty of Electrical Engineering in Ljubljana, and in 1935/36 he served as a military officer at the Reserve

Officers' College in Sarajevo. From 1936 to 1945 he worked in Zagreb as a Siemens representative. In 1937, he was sent to a five-month specialization in Berlin, therefore in Nazi headquarters. In April 1941 Šinkovec was captured as a soldier at Zenica and Šinkovec was detained to the camp in Osnabrück until 1942. He did not participate in the NOV and only decided to enter the ZK after the war. On 13 November 1945, he was admitted to the ZKJ based on his merits in protecting his company's assets against German confiscations during the war. Between 1945 and 1946, Šinkovec was the representative of Rade Končar in Zagreb. In 1946/47 Šinkovec was a delegate at the Yugoslav military delegation in Budapest (Jugoslovenska vojna delegacija u Budimpešti). In 1947 and 1948 he was Director of the Iskra Telecommunications Industry in Kranj, which was too low for him. In 1949 he was the Chief Director of the Federal Department of Electrical Engineering, where folks unsuccessfully proposed to exclude Šinkovec from the ZKJ for financial irregularities in October 1949. According to Croatian sources, Šinkovec was a typical representative of the old Siemens clique as the CEO of the Federal Directorate of Electrical Industry. Šinkovec even offensively offended the republican delegations, such as the Slovenian ones. In Iskra, they remembered Šinkovec as a good organizer, but among workers Šinkovec was rated as autocrat. He traveled abroad with Dr. Milan Lilek from Silvo Hrast's Iskra, which Bernik did not consider good for Šinkovec.

After the collapse of the Ljubljana (Yugoslav) nuclear project, Lucijan Šinkovec's (* 2. 6. 1914 Laze by Logatec; † 1966 Ethiopia) resigned from IJS on 15. 5. 1963 and went to similar work in Africa, but there he was hit by a car in Ethiopia in 1966.

On March 5, 1959 Peterlin concluded a contract with the IJS to work on NMR organic crystals by studying the dependence of spectra on temperature and nuclear radiation. He should not be paid during the planned collective leave and during Peterlin's stay abroad so Peterlin probably did not get much money at all. The anticipated receipts were even considerably lower than those designed by Hadži's command a few days later. Šinkovec offered only a basic salary of 34,800 dinars, a positional salary of 15,000 dinars and a special institute allowance of slightly over 8,000 dinars per month. Since

³³⁴⁹ Peterlin, 1981, autobiography.

Peterlin was supposed to be at the IJS only three hours out of the obliged seven working hours a day during the six working days of the week when the Saturday was still a working day, only 3/7 of these amounts belonged to him, that is, 14,900 dinars, 6,400 dinars and 3,400 dinars respectably.

The realization did not happen, because after some Moljk's direct scandalous shouting, for which Peterlin appealed in writing to the director of Šinkovec, Peterlin slowly decided to work abroad. According to Peterlin, Kraigher have removed him to some extent even against Ranković's instructions. The cards were later turned back; B. Kraigher harshly criticized Ranković at the 4th plenary session of Brioni on 1st July 1966, after Maček criticized Ranković's attacks against Kardelj who cooperated with Soviet pre-war agents including Kardelj, Josip Kopinič (1911 Radoviči by Metlika-1997 Ljubljana), Vladimir Bakarič and the prime minister Petar Stambolić (1912-2007). They arranged the wiretapping affair against Ranković, comparable to Obama wiretapping of Trump in 2016. Kraigher was still angry because Ranković opposed Kraigher's deadly Dachau processes in 1945. Stane Kavčič was even worsen in Brioni as everybody knew that Stane used to be in love with future Ranković's Slovenian wife earlier during the WW2, just like the Montenegrin UDBA general Jovo Kapičić (Kapa, 1919 Gaeta-2013 Beograd) used to love Tito's unmarried wife Davorjanka Paunović.

Ranković's most acute political error was that he began to wear the same type of bright hat as Tito! With that hat affair, everybody knew that Ranković looked forward for Tito's heritage while Jovanka and Kardelj nursed the same ambitions.

After the dismissal from the post of President of the Scientific Council of the IJS, Peterlin went abroad despite the contract with IJS. He first visited Stuart at the Institute of Physical Chemistry at the University of Mainz. On 9 March 1959, he left Ljubljana and researched the thermodynamic stability of individual polymer crystals with Stuart's assistant Erhard Wolfgang Fischer (* 16. 2. 1929 Wiederau south of Leipzig; † 2011). By the NMR they investigated the crystals of polyethylene, which Peterlin was already researched to in Ljubljana. In 1957 in Mainz independently from Hungarian Jewish immigrant Bristol PhD student Andrew Keller in the UK, and

P.H. Till of Research Division, Polychemicals Department, E. I. du Pont de Nemours & Company, Wilmington, Delaware in USA, Fischer discovered that crystals of polyethylene contained folded (wrinkled) molecular chains. The discovery has completely changed the situation and has become the new major branch of polymer physics. Just before the WW2 Gilbert Newton Lewis's PhD student-discoverer of hydrogen bounding Maurice Loyal Huggins (1897 Berkeley-1981 California) was the first to adequately determine the viscosity of large molecules, the existence of which some scientists rejected. Some scientists still doubted even their existence.³³⁵⁰ With the professor Günter Victor Schulz (1905 Łódź-1999), head of the Institute of Physical Chemistry at the University of Mainz, Peterlin completed his paper Determining the size of molecules from rheological measurements (Calculations of the molecular length from rheology data) on July 13, 1959. There he devoted special attention to the additional problems caused by the molecular diversification and branching.³³⁵¹ He reported on similar research in Basel at the Second International Expert Meeting on Laboratory Technique, Measurement Technique and Automation in Chemistry from 15 to 20 October 1962.³³⁵²

Between 1955-1957, Peterlin was serving as president of the board of directors and the president of the council at the IJS before Kajfež replaced him in the position of director. While serving as president of the board of directors, Peterlin was also the president of the council at the IJS. In 1957, he was replaced by Boris Kraigher as chairman of the board of directors and in 1958 the post was taken over by the Republican Secretary for Industry and Craft the engineer of metallurgy Viktor Kotnik (* 1910 Zgornji Jakobski Dol; † 1991 Ljubljana) who vetoed the erasing of J. Stefan's name of the Institute on 12 June 1959. Thus, Kraigher was delegated by politicians to regulate relations with the IJS; he could not keep Peterlin from fall, and Kraigher was "no fan of Peterlin".³³⁵³ On 13 December 1959, Peterlin wrote to Kraigher from Cambridge University in Boston and thanked him for helping to obtain the ZKNE scholarship. Peterlin "perfectly anchored" in

³³⁵⁰ Bartol, 1961, 109.

³³⁵¹ Peterlin, Determination 1959, 116.

³³⁵² Peterlin, Bestimmung 1963, 68.

³³⁵³ Peterlin's letter to Ivan Supek in Zagreb on 12. 10. 1960 (GDP).

Cambridge, although he must "because of some partial calculation depart for Philadelphia." Of course, he told Kraigher that he wanted to stay abroad for a year longer, where everybody is trying to make his work as smooth as possible, while at home Moljk "tries to make my life as hard and unbearable as possible, to dismiss my secretary (sister Marja Lapajne), to destroy the group which I led, and prevent us from perfecting our device. For a year now, it lies a laminated magnet wrapped in a paper that cost only \$ 10,000 and was ordered in my time, without the hope that it would ever be used for scientific research for which it was purchased because they refuse to buy additional parts, because it would be used by me and the people who have cooperated with me so far. An institute analogue calculator is offered to other folks in Ljubljana; unfortunately, there are no interested parties outside of the institute to prove that the idea with it was one of my nonsense, so Kuščer uses that computer at his classroom ..."

Peterlin figured that his successors did not prove their capabilities in six months of their IJS leadership as they wasted the efforts of past ten years of their complaints against Peterlin mailed to the Beograd government.

Peterlin announced to Kraigher his departure to Detroit in March 1960; there he calculated a diffusion problem with his results from Mainz on a powerful computer. He gave Kraigher plenty of technical detail, which Kraigher could not understand. To some extent, Peterlin tried to justify his state scholarship with these details, but on the other hand he showed his strength with knowledge.

After six months spent in Mainz, Peterlin was in Ljubljana since June 1959. On 11 September 1959, the University of Ljubljana granted Peterlin an extended leave for eight months. During a visit to Harvard in Boston (December 1959-March 1960), Peterlin received a tempting invitation to run the Physics Institute of the University of Munich. While working at Wayne State University in Detroit from March to June 1960, Peterlin received a professor's degree at a local university. He could not decide for a long time about living Slovenia. The decision fell only on July 19, 1960 after the arrival of his wife and son in Villach.³³⁵⁴ on September 1, 1960, he took over the leadership of

the Physics Institute of the Technical University of Munich until 1961.

Boris Kraigher informed Peterlin that the problems on the IJS continue under the new leadership. Kraigher suffered from Ranković's criticism of Kraigher's firing Peterlin. Therefore, Kraigher wished to arrange Peterlin's personal visit to which the newspapers would report; so, he would conceal from the public that Peterlin immediately got a higher position in Munich after being forced out of Ljubljana. The insane people of Ljubljana were, of course, crying out that German physics was no longer what it was, with the Bavarian Munich included. Such newspaper report indeed appeared.

On 26 November 1959, Peterlin wrote the last of his papers at the IJS where with his colleagues he published his first NMR study. According to Stuart's (1958) measurements of rubber full of doubts in the crystallinity of polymeric solids,³³⁵⁵ Peterlin and co-authors for their measured material selected polyethylene and proved irreversible crystallization. Peterlin used NMR to research the re-crystallization of polyethylene.³³⁵⁶ It was discussed in Pirkmajer's graduation thesis at a time when Peterlin was already in Munich. The chemist Marinković prepared monocrystalline samples, dr. Blinc did the math, and Miss M. Pregelj took over the measurements.

In the spring of 1961, Kraigher invited Vidav, Kuščer and Dominko to his office, and ordered them to try to attract Peterlin back to Slovenia. Dominko visited Peterlin in Munich in April 1961. Dominko tried to persuade him to return to Slovenia. Fourteen-year-old Boris Matija Peterlin loaned his room to Dominko during his visit, while Boris Matija Peterlin himself slept with his old mother. Since Dominko could not offer him anything tangible, Peterlin preferred to stay abroad, although, according to Osredkar, he could never get used to the emigration completely. He just dreamed Slovenian Alps and Moljk's revenge.³³⁵⁷

In 1961, Peterlin went to the US and continued with successful research and organization there. In

³³⁵⁵ Peterlin, Krašovec, Pirkmajer, Levstek, Dilatometric 1960, 231, 242; Peterlin, Pirkmajer, Temperature 1960, 185, 192.

³³⁵⁶ Peterlin, NMR 1963, 102.

³³⁵⁷ Peterlin's letter to Kraigher signed 11. 5. 1961; Kraigher's letter to Peterlin signed 26. 7. 1961, page 1 (GDP).

³³⁵⁴ Message of Tanja Peterlin-Neumaier 17. 12. 2006.

the meantime, he particularly enjoyed lecturing in Slovenia, especially at the IJS, but only after the new Director Osredkar renewed contact with him in 1963. Peterlin particularly enjoyed lectures in Slovenia, especially at the IJS after Moljk's departure in 1963. Osredkar as the new director of the IJS introduced an efficient order again. Peterlin's lectures in IJS were well attended until once Peterlin had to live the auditorium in hurry with the scaring whisper "Ah my God".

The Americans, of course, hurried to put Peterlin on the leading position of the new institute in North Carolina because they knew all about Peterlin's successes in the organization of the IJS. The Americans, of course, were eager to take Peterlin to the leading position of the new institute in North Carolina. As director of lab at Camille Dreyfus in Durham, North Carolina. Peterlin studied macromolecules of plastic in a situation that could only be dreamed about at home.

In 1961-1973 in North Carolina, he studied macromolecules with the help of chemist developer of polymer synthesizers Anton E. Schindler (* 1921) of Research Triangle Park Institute in North Carolina, head of the research laboratory of Celanese Corporation of America, New York Robert Thexton Armstrong (1909-1992) and other physicists who worked mostly in the laboratory for a year or two. The Laboratory was founded a few years after the death of pioneers of artificial fibers, chemicals and plastics, the Dreyfus brothers. Dreyfus succeeded in synthesizing acetate fibers so that they could be set up by Celanese Corporation.

After compulsory retirement at the age of 65, he worked at the National Standards Bureau (NBS) in Washington DC between 1973 and 1984, after 1975 as Assistant Director of the Polymers Department. In Slovenia, he collaborated primarily with Robert Blinc's group focused on NMR. After the second retirement, Peterlin studied in his office at the NBS until his second hip fracture in December 1991. In mid-September 1978, the American Chemical Society published Peterlin's biography with a report on his scientific work in a special book. Peterlin delivered the copy to SASA

and thanked the president Milčinski for his birthday cards.³³⁵⁸

Until then, in the lobby of the NBS, in those times called NIST in Washington DC (Gaithersburg), they hung a large oil portrait of Peterlin, which was brought elsewhere after 1991. Peterlin was certainly successful boss, but not the beloved one. After compulsory retirement at the age of 65, Peterlin's great several meters high oil picture in Camille Dreyfus in Durham was immediately removed as his high profiled autocratic leadership was never extremely popular among his collaborators as Podgornik noticed.

30.1.4.8 Pedagogical and Populatisation Efforts

In 1955, after Gosar's graduate thesis, Peterlin used the nuclear magnetic resonance which later became the main tool of Peterlin's student Blinc. Many Peterlin's graduates, even those who did not accomplish doctorates later excelled in physics. In 1962, Milavc and Bezić published a discussion on the total absorption of gamma rays together with D. Jamnik, Kernel and others. In 1975, at the first symposium on applied physics in Škofja Loka Milavc, Marjan Hribar, Moljk, Jože Trontelj's and others presented work and results of physicists in Slovenia.

As a professor, Peterlin had a special tactic of questioning. He jumped with his questions from field to field until he thought he had found a candidate's weak point. There he stopped and tried to drill as deeply as possible. This approach enabled Črt Zupančič to take advantage as Črt deliberately pretended to be unsure in the topics he prepared the best for his exam. Črt Zupančič had some previous acquaintance with those funny kinds of questioning as Črt Zupančič's Grammar School teacher of Latin languages Rudolf Južnič also used to post very quick questions in his class while jumping from one student to another which forced everybody to be prepared for each lesson. Later, Črt Zupančič confessed to Peterlin about his misbehaviour on exam, but Peterlin's was then already Črt Zupančič's colleague; so, he was not very upset at all.

³³⁵⁸ Peterlin's typescript letter addressed to J. Milčinski on 30. 9. 1978 on quarter of page of A4 format (Archive SAZU, courtesy of Drago Samec).

Peterlin has published over 350 papers. After the initial interest in scattering X-ray light in liquids, he described the plastic deformation of crystalline polymers and transport properties, thermodynamics, crystallization, morphology, nuclear and electron magnetic resonance in polymeric solids. In between, as the IJS director Peterlin introduced nuclear physics in Slovenia.

After the WW2, Peterlin also edited the *Proteus* magazine for two years. Peterlin later edited *Macromolecular Reviews* and co-edited many other magazines. In *Proteus* Peterlin relatively sharply criticized the article of Beograd meteorologist Fran's son Marijan Čadež, although in 1942 Marijan Čadež with the dissertation of the influence of turbulence on the formation and development of inversions and on the development of zero-degree isotherms received his doctorate at the class of Anton Melik, Oscar Reya and then assistant professor Peterlin.³³⁵⁹ The leading Beograd meteorologist Marijan Čadež formally led the meteorological studies in Ljubljana in 1961 and 1962 which was far from Peterlin's wishes.

In 1968, Peterlin became an honorary member of the IJS, in 1983 he received the Kidrič Prize for Lifetime Work, and in 1988 he was awarded the Honorary Doctorate at the University of Ljubljana. In 1988 at Osredkar's initiative a statue of Peterlin was placed in front of the Jožef Stefan Institute just a few months before Peterlin's eightieth birthday. In 1992, Peterlin returned to Ljubljana as a retired person, but died after a few months. On the 50th anniversary of the IJS, Osredkar and colleagues published a monograph on the IJS, which was largely devoted to praiseworthy memories about Peterlin.

30.1.4.9 Thin Films at IJS in the Shadow of Nuclear Physics

30.1.4.9.1 Introduction

The research of thin films on the IJS developed within the Yugoslav nuclear program. Ranković's efforts for a Yugoslav atomic bomb lasted for two decades (1947-1966). The interior Minister

³³⁵⁹ Peterlin Anton. 1946/47. Perpetuum Mobile and the "pulse theory of motion", Book Review of Marjan Čadež's pulse theory of movement, which supposedly occurs in the atmosphere as a picture of phenomena in the universe. 1946. Self-publication. *Proteus*. 9: 17-19.

Ranković as vice president of the ZIS (1955) and vice-president of the state (1963-1966) as the second man in the country searched for Yugoslav nuclear raw materials, educated personnel and to prepare reactors. Even though the main center of Savić's Vinča was in Belgrade, they spent a large part of the funds for the IJS under Peterlin's and later under Čopič's and Osredkar's leadership. Peterlin was hoping for the American Oppenheimer's role to develop the Ljubljana Physics Institute in the shadow of the bomb. The new materials and accelerators were closest to Peterlin. From the rich table of nuclear research, income was also pouring out for the various directions of research at the Physics Institute. According to the original Peterlin's scheme, which has been preserved in many versions up to date, Peterlin primarily advanced various forms of research of (solid) matter: on the one hand, Marinković's laboratory for analyzing materials with X-ray and electron microscope of Carl Zeiss acquired in October 1954 and, on the other side the rapidly evolving Dekleva and Cilenšek's mass spectroscopy with accelerators.

30.1.4.9.2 Investigation of Matter in the Shadow of Atomic Mushroom

Velibor Marinković, together with Ljubo Knop, produced heavy water with electrolysis and thermo-diffusion until autumn 1956. It turned out that efforts of this kind were merely a waste of time and money, as imports of nuclear raw materials and reactor technology were already released during Peterlin's roaming in the US before the First International Conference on the Peaceful Uses of Nuclear Energy in Geneva on 8. 8.-20. 8. 1955, attended by Kosta and Dekleva from the IJS. The countries without adequate technical possibilities for their own production of nuclear raw materials, especially enriched uranium and heavy water, have since been able to get them on the free market, and indeed even with American gifts. According to Peterlin's report at the first session of the IJS Committee under Kraigher's leadership, this situation changed,³³⁶⁰ which probably also undermined the service of Czech Zagreb's Havliček at the IJS. Peterlin began sending people to trainings in the US.

³³⁶⁰ ARS, SI_AS 1961 box 71, map 722.

Table 30-2: Peterlin's graduate students and doctoral candidates

Year	Name of graduate	Diploma / dissertation (d) title
1954	Milan Osredkar	Counter based on Cherenkov (Čerenkov)
1955	Vekoslav Ramšak	Penning's ion source
1955	Marko Vakselj	Calibrations of the energy scale beta... / 1958d dissertation Analysis of photonuclear reactions
1955	Ivan Zupančič	Nuclear Magnetic Resonance
1955	Savo Poberaj	Sedimentation in inhomogeneous
1956	Zdravko Gabrovšek	Determinations of technical conditions for research of crystals with electronic interference, with respect to the experimental possibilities for electron microscopy at the Jožef Stefan Institute in Ljubljana
1955d	Peter Gosar (* 1923)	Diffusion of light in an optically non-homogeneous medium if the differences in refractive indexes are small (Nuclear Magnetic Resonance)
1956d	Milan Čopič	Influence of solvent on the optical analysis ...
1955	Janez Dekleva	Energy conditions in the radiofrequency mass spectrometer
1956	Rudolf Kladnik	Two group conversion reactor
1957	Niko Bezič	Analysis of magnetic spectrometers for heavy particles (diploma)
1957	Leopold Debevec	Thermal ion source for Nier's (Alfred Nier (1911-1994) mass spectrometer: diploma graduate work
1957	Janez Strnad	Double group approximation for neutron diffraction in a reflector: diploma work
1957	Zdenko Milavc	Reaction Measurement ($^{31}\text{p} \rightarrow (\gamma, n) + ^{30}\text{p}$): diploma graduate work
1957	Uroš Miklavžič	Measurement of Gamma Spectrum
1957	Franc Herman	Albedo and permeability of non-homogeneous single-stranded neutron fluxes in Reflectors: graduate thesis
1957	Robert Blinc	Infrared spectra and shape of the potential function of the hydrogen bond KH_2PO_4 and KD_2PO_4 in the non-ferroelectric and ferroelectric phase
1957	Jože Pahor	Thickness measurement with radioactive isotopes
1958	Đorđe (Đuro) Bugarinović	Optical properties of Compton's spectrometer: graduate thesis
1958	Franc Cvelbar	Processing neutron generator
1958	Silvester Šterbal	Measurement thresholds reactions
1958	Božidar Jordan	Forms of boiling reactor
1958	Stanislav Zazula	Construction of microphotometer
1959	Edo Pirkmajer	Temperature dependence of nuclear magnetic resonance for a solid polymeric: graduate thesis
1959	Milan Pintar	Research of rotors CH_3 and CH_2Cl with nuclear magnetic resonance: graduate thesis
1960	Bogo(mir) Mihelčič	Polydispersity of fifth polymerization of poly-acenaphthene: graduate thesis

On 9 October 1956, Peterlin wrote to Nakićenović about Knop's proposal for the gradual abandonment of the heavy water department, which only became a financial burden since importation became possible. Savić agreed with the proposal, although he was often unsupportive to Peterlin's ideas. Since then, Marinković has been able to devote entirely to the study of substances and surfaces. In 1956, he examined ten domestic and three foreign PVC samples. Molecular masses of polymers were determined, and for the new ones they used better preparatory procedures for carbon filling and plastic impressions with polyester in a vacuum. Alenka Dekleva studied erythrocytes for her investigation of virus cultures; she researched with Marinković between 1954-1960, and then, due to the ever more difficult acquisition of funds for the study of macromolecules after Peterlin's departure, she took over the professorship at the Faculty of Medicine in Ljubljana. They also offered their electron microscope for external users, since they were almost free of competitors until the spring of 1955, Aleš Strojnik assembled an electron microscope with 50 kV and a resolution of 5-2.5 nm at the Faculty of Electrical Engineering at the Technical College in Ljubljana. In 1956, Marinković's group examined a sample from the lake through an electron microscope for the Geological Institute, while eighty zinc oxide samples were collected for Cinkarna Celje. In 1957 Boris Navinšek joined Marinković's laboratory for electron microscopy. Marinković's group also studied the scattering of X-rays on crystals in the form of dust according to Debye's (1916) method, which Peterlin knew well from the time of his Berlin studies.

30.1.4.9.3 Accelerators and Thin Films in the Shadow of the (Yugo)Slovenian A-bomb

Excellent experts in electronics and vacuumists were the foundation of Peterlin's Institute, among them Dekleva and Cilenšek, who in the Slovenian context became the true heir to the American Nobel laureate Lawrence, his assistants Livingston and Van de Graaff. On 2 January 1950 and on 3 October 1950, Peterlin exceptionally wrote his manuscript and did not typewrite a report to minister Boris Kidrič³³⁶¹ about the construction of the largest neutron generator. He reported on basic measurements of nuclear sections for

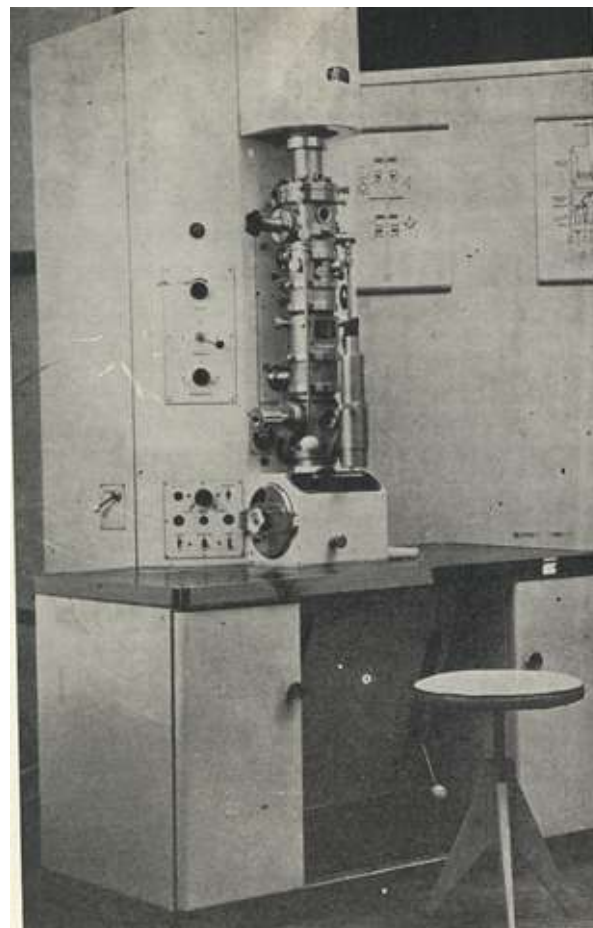

Figure 30-8: Electron microscope in Marinković's Laboratory IJS

uranium copper planning. In another letter he said that he did not want to buy a 1 MeV generator. He planned the purchase of an electrostatic Van de Graaff generator for \$ 200,000. It was first designed in 1931 as an improvement of the electrophorus electrostatic generator with the idea of a transformer to increase the tension by the old Guericke's ideas promoted in 1671. The charging of the electrostatic generator with a conveyor belt was first described by Righi in Bologna in 1890. He rearranged an older W. Thomson idea of a generator on charged drops of water. On 27 November 1954, at the IJS, in the laboratory of Edvard Cilenšek "for the construction and maintenance of accelerators", the electric part of Van de Graaff generator of domestic production began to be used after long-term design, construction, assembly and testing of individual parts in 1953-1957. IJS Van de Graaff of a closed type under pressure of 10 bar of nitrogen could direct elementary particles to the target in the range between 200 kV and 2.3 MV. A high vacuum in the acceleration cathode ray tube was used with a diffusion pump with a pumping speed of 500 l/s. In

³³⁶¹ ARS, SI_AS 1961, box 1, map 1.

May 1956, their beam was accelerated for the first time through a tube with a voltage of 2 MV at a pressure of 8 bar. After Peterlin's departure, in March 1961, an accelerator of 1.8 MeV was completed.

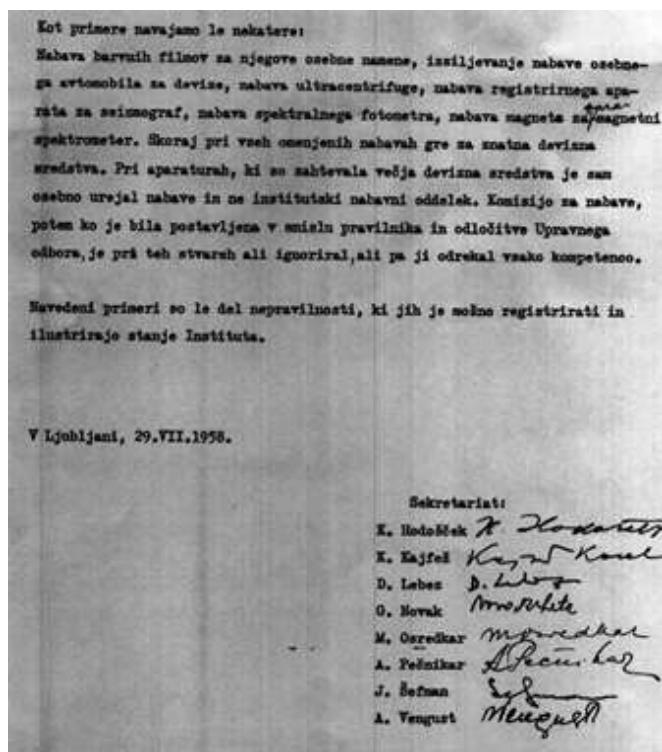

Figure 30-9: "Analysis of the Secretariat of the OCC ZKJ on the situation at the Institute" reported to Boris Kraigher in the middle of the summer heat on 29. 7.1958 (ARS, Government of the Republic of Slovenia, 1945-1992, AS 223, box 701 (thanks to Aleš Gabrič for help)).

Due to the interest of the head of the spectroscopic laboratory Dekleva for the microtron, Peterlin invited two engineers who built their own microtron. It was intended for research in medicine instead of betatron, although its use was questionable due to the low energy. The engineers completed a month of their training in Sweden, and the microtron was to be displayed at the Economic Exhibition Center at the exhibition of electronics as a great device in 1957. Although this was not the case, and the Scientific Council decided that the IJS would not attend the exhibitions.

Of course, the microtron produced much less noise and was therefore more suitable for public exhibitions than the Van de Graaff accelerator, which caused a rather unpleasant noise by sparking. One engineer was Požar, the other was Alojz Paulin, who started working in J. Dekleva's

laboratory in October 1955, and in 1948/49 became Peterlin's student demonstrator at the Physics Institute. Paulin was assisted by student of mechanic engineering Mihael Svetlin and Franc Požar, who worked at the IJS between 1956-1963 to finish his master's degree work entitled Interaction between electron beam and electromagnetic fields in resonators in 1962, and then went to the Netherlands. Paulin worked for two and a half years on a 3-cm microcontroller micro-throne with a tolerance of $1: 10^8$ until he was banned from further research and had to obtain a special permission to test the device in the afternoon in his spare time. The problem was particularly interesting to Paulin, although he had some problems with his own slow blood clotting because of poor radiation control in IJS. After seven years of service, Paulin went to develop accelerators together with Požar for Desy (Deutsches Elektronen-Synchrotron) in Hamburg in 1962/63, and then went to Debye's former student Paul Scherrer's (1890-1969 Zurich) Institute in Zurich. Požar remained abroad while Paulin returned and then lectured at FERi in Maribor.³³⁶²

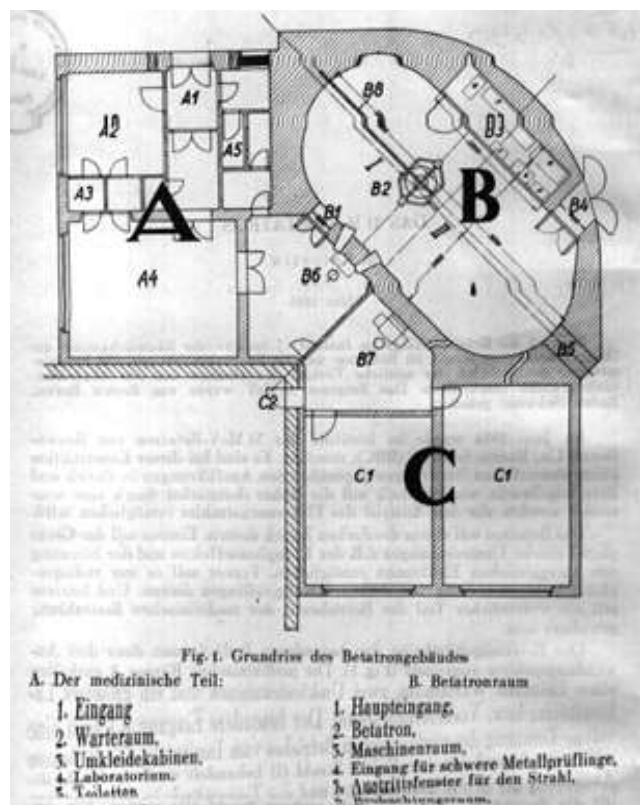

Figure 30-10: Betatron at the IJS (Peterlin, 1955. Das 31 MeV Betatron, 34)

³³⁶² Dekleva, 2000, 203; Alojz Paulin, personal message on 6. 2. 2007.

Besides the increasingly outdated Van de Graaff, the betatron and the neutron generator, Peterlin and Dekleva were also interested in other American accelerators. In 1952, Livingston together with Ernest D. Courant and independently of the two years older efforts, published the idea of strong focusing as the basis for the work of all subsequent powerful accelerators. After the first model made of glass, Lawrence, with the help of his student Livingston, assembled a second cyclotron from the metal. With a 2000 V voltage, it could accelerate hydrogen ions to 80 keV energies. Livingston proved in his doctoral thesis the utility of the principle of cyclotron resonance on 14. 4. 1931.³³⁶³ Lawrence and Livingston were the first to accelerate protons over 1 MeV; but they did not break the nucleus of the atom before Cockcroft and Walton success in the British Cavendish Laboratory.

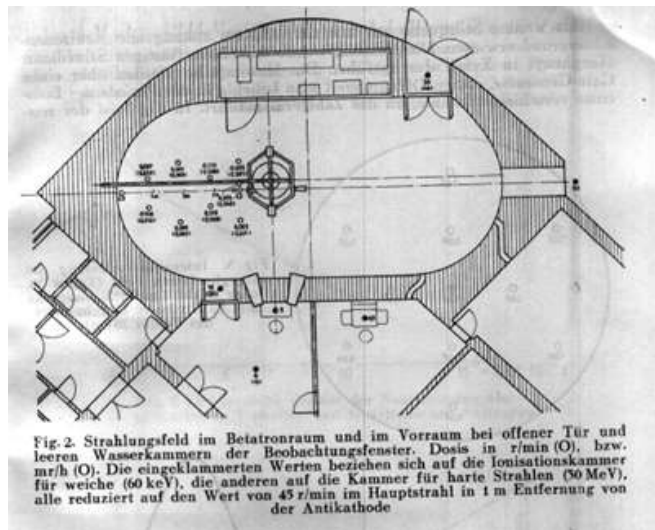

Figure 30-11: The drawing of the machine space of betatron at IJS (Peterlin, 1955. Das 31 MeV Betatron, 35)

Upon his eight-month visit to the United States, Peterlin was well acquainted with the situation in the following year. Lawrence passed away and the upcoming Livingston star. Peterlin decided to send one of his major colleagues, Dekleva, to Livingston's lab. On 20 October 1957, Kajfež wrote to Dekleva in the US that his wife Nina must have already told him how the IJS had granted him a year of unpaid leave in the United States, where she would join him. However, Kajfež asked Dekleva to send the promised reports to the IJS. Upon the fall of Peterlin, Dekleva returned to the

³³⁶³ Livingston, Blewett, 1962, 134.

IJS, and then again returned to M.S. Livingston's USA. In December 1959 he was again in the IJS. As the head of the previous Cilenšek's Accelerator and Electrophysical Department, Dekleva trained the Van de Graaff accelerator guys for the work in nuclear physics. His associate engineer Anton Brinšek maintained the betatron, and two pulsed neutron generators were assembled for reactor physics in 1961. A magnetic mass spectrometer for the chemical department and omegathrone mass spectrometer have also been constructed as useful tool for detecting vacuum leakage up to $1.33 \cdot 10^{-9}$ mbar \cdot s⁻¹.³³⁶⁴

In the summer of 1959, Livingston, as director of the 6 GeV accelerator in Cambridge which was used by the researchers of Harvard and MIT, visited the IJS to talk about further Dekleva's specialization in the USA. However, the new director of the IJS, Lucijan Šinkovec nicknamed "a valve" after Ranković's pressure for the construction of the Ljubljana reactor changed his mind overnight and called Dekleva back home.

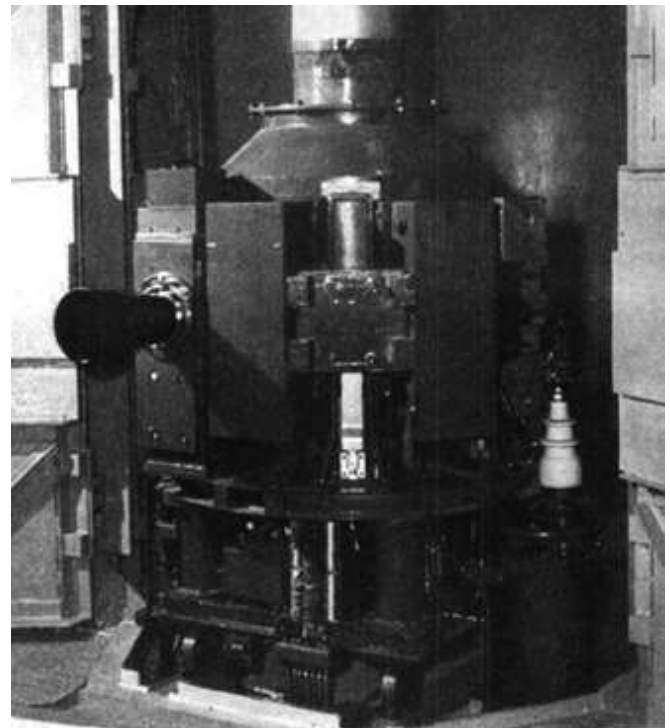

Figure 30-12: Photograph of betatron at IJS (Peterlin, 1955 Das 31 MeV Betatron, 38)

In December 1959, Dekleva was again at the IJS. As the head of the Cilenšek's Accelerator and Electrophysical Department, he was trained on the Van de Graaff generator for the work of nuclear

³³⁶⁴ ARS, SI_AS 1961, box 11, map 25.

physicists. His associate engineer Anton Brinšek maintained the betatron, and in 1961 two pulsed neutron generators were assembled for reactor physics. They developed a magnetic mass spectrometer for the chemical department and omegatron mass spectrometer for detection of vacuum leakage up to $1.33 \cdot 10^{-9}$ mbar \cdot l \cdot s⁻¹. In August 1963, Cilenšek began to lecture at the Split Faculty of Electrical Engineering, Mechanical Engineering and Shipbuilding, and later at the Faculty of Mechanical Engineering in Ljubljana.³³⁶⁵

Union,³³⁶⁶ but later Peterlin's collaboration was limited to the Polish people. On 14th May 1957, at the ZKNE meeting in Supek's absence, the agreement with Poland on the peaceful uses of nuclear energy was confirmed. On 5 November 1957, Barbarič informed the IJS that they would send to Ljubljana practice Lech Borowski and the other Poles according to an agreement approved by ZKNE. However, Kajfež was very angry because, despite the announcement of the Poles, they did not show up at Ljubljana in time. After this exchange, Cilenšek departed for a month in Warsaw in November and December 1957, and Osredkar went there for three weeks.³³⁶⁷ Later, Navinšek visited the Warsaw Physics Department to complete his knowledge of Strojnik's electron microscopy by accurate processes of measurement of the grid constants of thin films by the electron diffraction.³³⁶⁸

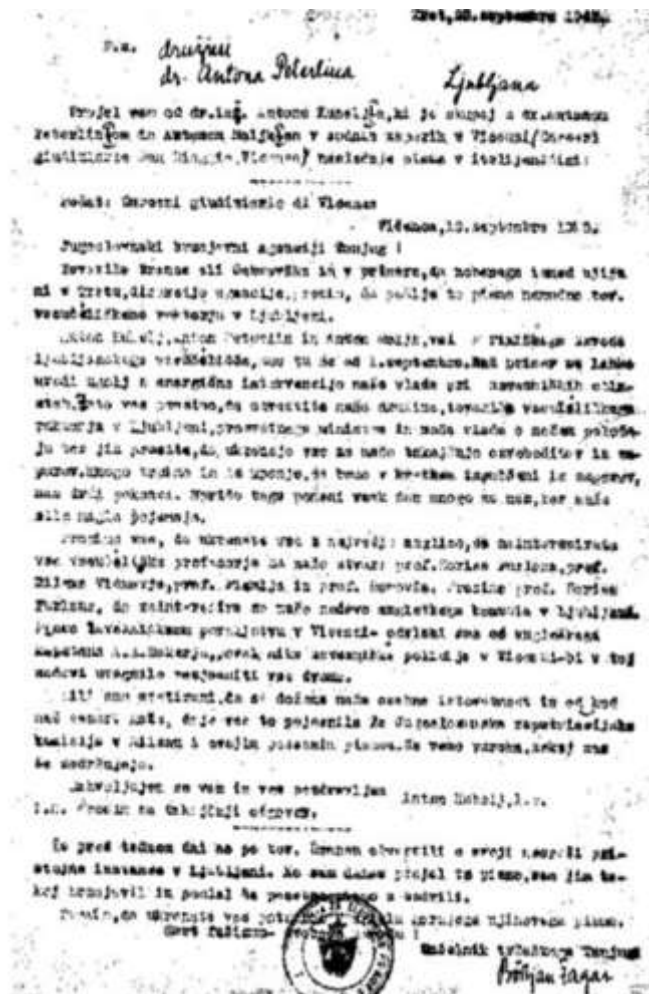

Figure 30-13: Kuhelj's letter "For Help" from the Italian prison where three Antons from the University of Ljubljana suffered after their failed acquisition of a neutron generator (GDP).

Unlike the Soviet block favoured by people from the Vinča Institute, the Peterlin's Ljubljana and Supek's Zagreb Physical Institutes were directed mainly to the West. In 1946, the delegation of the Slovenian Academy of Sciences and Arts together with President F. Kidrič visited the Soviet

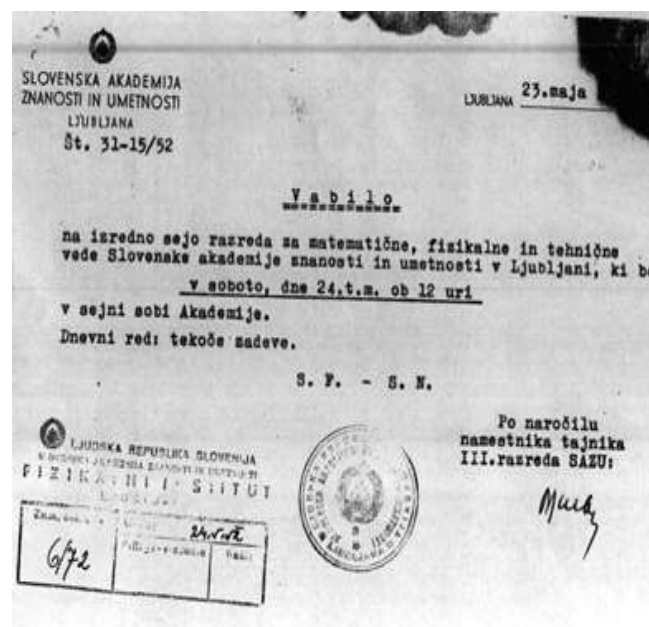

Figure 30-14: Invitation dated 23 May 1952 to an extraordinary meeting of the class for mathematical, physical and technical sciences of the SAZU dated 24 May 1952, led by deputy secretary Peterlin where they successfully renamed the Physics Institute in the IJS. Peterlin headed the meeting instead of the absent secretary Milan Vidmar, Josip's brother. Peterlin successfully proposed renaming of the Physics Institute in the IJS with a typical conclusion of SF - SN! (Death to Fascism - Freedom to the People) (ARS, AS, box 1, map 1; ARS, AS, box 2, map 5).

³³⁶⁵ Dekleva, 2000, 202-205; Osredkar, 2000, 319.

³³⁶⁶ Message of Aleš Gabrič on 31. 1. 2007.

³³⁶⁷ ARS, SI_AS 1961, box 11, map 25.

³³⁶⁸ Navinšek, 2000, 160; Panjan, 2002, 43.

After Navinšek's return, the electro-technicians "of weak currents" at the IJS were no longer exercised only at the Cilenšek, Dekleva or Bremšak's departments for accelerators, mass spectroscopy or electronics, but also in the department for the research of materials of the chemist Marinković (r-9). Everything started at the renewed Ljubljana Physics Institute with a neutron generator, which the three Antons (Kuhelj, Moljk, Peterlin) tried to acquire in Vincenza immediately after the war with a lot of money in their bags. When Kidrič only allowed the acquisition later, attempts were by no means limited to A-bombing and reactor efforts. From the neutron generator, which was in the bad and in the good period the base of the first decade of the development of the Ljubljana Physical Institute, the electro-technician Navinšek used a beam of radio-frequency source for the first measurements of the sputtering coefficients after his return from Hamburg in 1961. In preparing the Yugoslav nuclear program, IJS has constantly developed advanced vacuum technology. Mostly the successful methods for ionic etching of radioactive materials with an argon ion beam have proved successful. The surface of ceramic samples of UO_2 and reactor graphite could be etched or prepared for analysis of its surface microstructure only with argon energy ions of several keV. Thus, ion bombarding became one of the fundamental technologies of reactor physics, even before the construction of the TRIGA reactor in Podgorica. What Peterlin conceived as the co-operation of researchers of macromolecules with industry, in fact, immediately after his departure from Ljubljana began to occur primarily with Slovenian thin-layer technologies. During the Manhattan project of manufacturing atomic bombs during the Second World War, Lawrence's postdoc the physicist-musician John Graham Backus (1911-1988 Los Angeles) of Radiation Laboratory, University of California in Berkeley and his colleagues developed ionization meters with the cold cathode, and in 1943/44 invented a vacuum meter in the vacuum system with a mass spectrometer. Likewise, the Slovenian physics also recovered from the shadows of the bomb. With only one "slight" difference: the Americans really made the bomb, while the Yugoslav bombers were deposited at the Brioni Plenum together with Ranković.

After the collapse or bankruptcy of the Yugoslav bombing program with Ranković's retirement, after

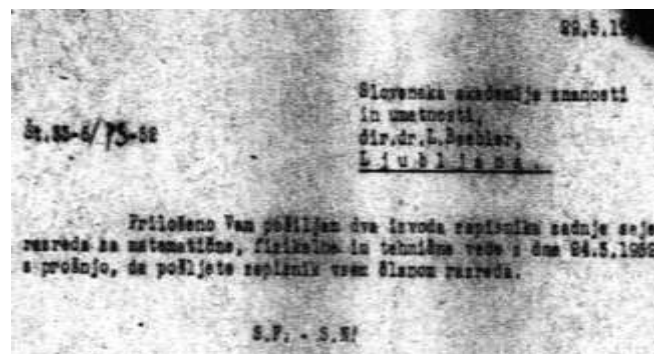

Figure 30-15: Peterlin's accompanying record to Kuhelj's notes of the extraordinary meeting of the class for mathematical, physical and technical sciences of the SAZU on 24. 5. 1952, sent to SAZU administration director lawyer the alpinist Nordic skiing fan Lev Baebler (1912 Žiri-1976) five days later concluded by the usual motto "Death to Fascism - Freedom to the People". Lev Baebler was the nephew of the chemist Balthasar Baebler (Baldi, 1880-1936) who was the father of the Bolshevik revolutionary Aleš Bebler (1907-1981) and the grandfather of the expert of defence studies Anton Bebler (* 1937). (SBL, 4: 1038; ARS, SI_AS, box 1, map 1; ARS, SI_AS 1961/18/5, box 2, map 5).

1975 it became interesting to study the formation of blistering in the (homogeneous) reactor core and the intense erosion of the first inner wall of the reactor vessel, for which it was difficult to find enough resistant materials in fusion (thermonuclear) reactors, as before the same problem bothered the physics of the homogeneous physical reactors, promoted by Peterlin's Group. Ion bombardment of solids and the production of thin metal layers gained its fundamental importance shortly after Velibor Marinković's section for electron microscopy was joined by Boris Navinšek in 1957.³³⁶⁹ Marinković graduated in chemistry, received his Ph.D. on December 29, 1965, and promoted on February 25, 1966 with Samec's former doctoral student Branko Brčić.³³⁷⁰ Jože Gasperič (1968) was among Marinković's doctoral candidates, while Navinšek obtained his diploma, a master's degree and a doctorate (after a one-year study in Liverpool) with Aleš Strojnik at the Faculty of Electrical Engineering. At the Faculty of Electrical Engineering few years before Navinšek Cilenšek and Dekleva also studied. In any case, the study of thin films requested a group

³³⁶⁹ Panjan, 2002, 43.

³³⁷⁰ Kokole, 1969, 62.

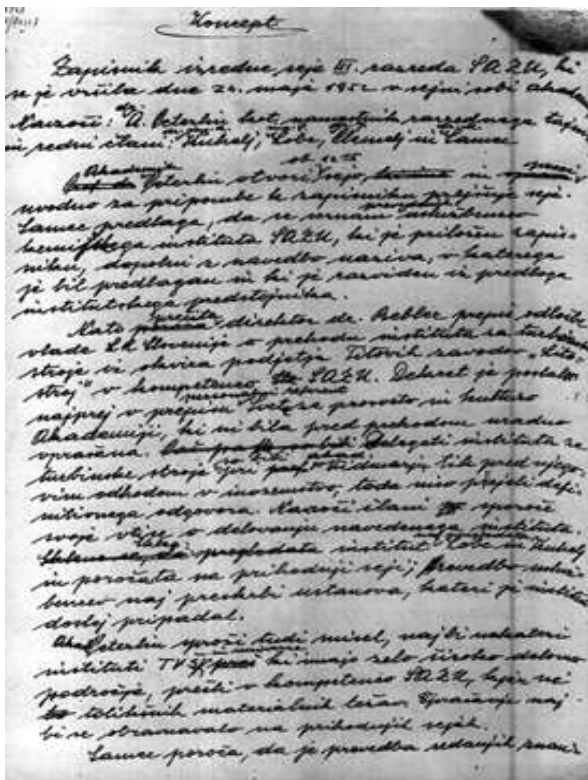

Figure 30-16: The first page of Kuhelj's manuscript record of the extraordinary meeting of the class for mathematical, physical and technical sciences of the SAZU on 24. 5. 1952, where Peterlin successfully proposed the renaming of the Physics Institute in the IJS (ARS, AS, Box 1, Map 1).

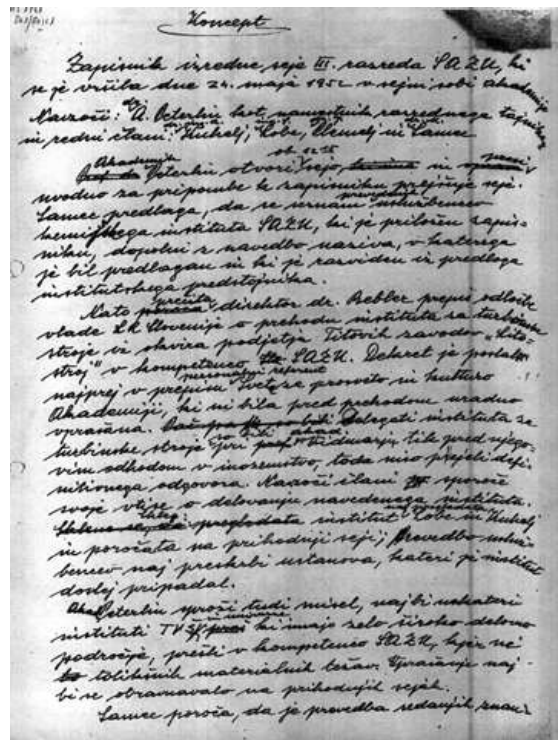

Figure 30-18: The first page of the manuscript of Kuhelj's record of the extraordinary meeting of the class for mathematical, physical and technical sciences SAZU dated 24.5.1952 (ARS, AS , box 1, map 1).

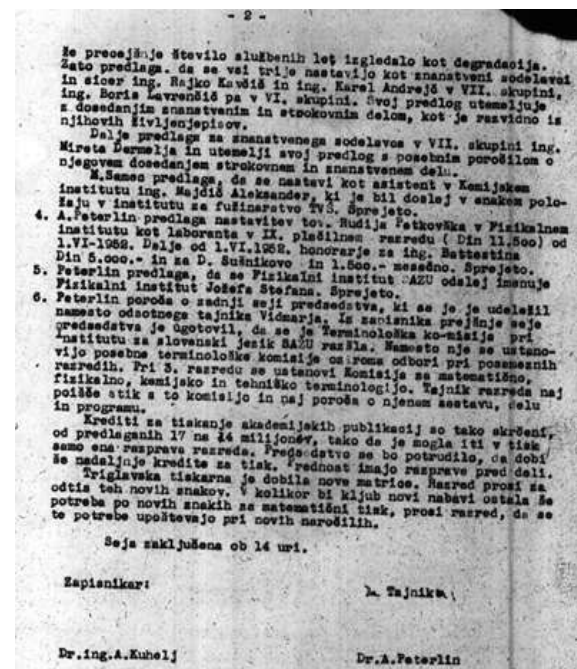

Figure 30-17: The second page of the Kuhelj's notes of the Extraordinary Session of the class for the mathematical, physical and technical sciences of the SAZU on 24. 5. 1952, where Peterlin successfully proposed the renaming of the Physics Institute in the IJS (ARS, AS, box 1, map 1).

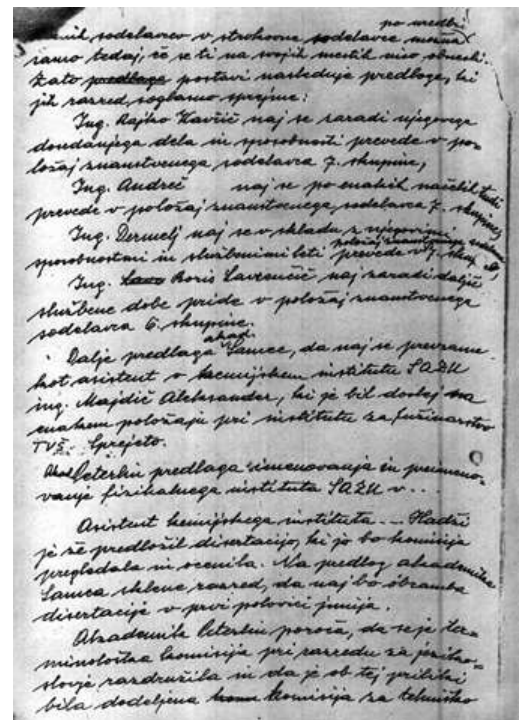

Figure 30-19: The second page of the manuscript of Kuhelj's record of the extraordinary meeting of the class for mathematical, physical and technical sciences of the SAZU on 24.5.1952, where Peterlin proposed the renaming of the Physics Institute in the IJS (ARS, AS, box 1, map 1).

SLOVENSKA AKADEMIJA
ZNANOSTI IN UMNOSTI
LJUBLJANA

Fizikalni inštitut

4 ultratermostati + termostatska opra sobe
fotoelektrični merilniki prepulšne svetlobe
ustrešni kontrolni in varnostni instrumenti, registrirane
razprave

5. Rentgenografija: 1 dipl. fizik
rentgeneka aparaturne s tehniškimi orodji za tehniške
preiskave (aparatura je tu, orodja so uničena)
rentgeneka aparaturne za vakuumski župljak za izmenjevalno
antikodoje in ev. in graditve rotirajoče antikodoje
ionizacijska kamera sa vlakna in tekočina s registrirano
aparaturno
fotografiska kamera sa filasa in večje Koss (rockstrahl-
verfahren)
komparator sa ismeritve fotografornov
fotometer sa meritve intenzitete

1 ultratermostat

Delavnice: 1 mehanik
1 elektrotehnik - mehanik
1 radijski tehnik
1 steklopilniš

1 strojnica
1 rezkar "Prvomajška", Jesenice, "Saturus"
1 shaping Zagreb Ljubljana
1 vrtilni stroj
s priborom, orodjem sa elektro in radijsko delo
1 steklaraka delovna misa s gorilniki in brusilnicama

Ves oddatek II. s delavnice potrebuje v letu 1949. za svojo
izgradnjo (le del tu naštetega načrta) poleg dena v Jugosla-
viji dosegljivih evrov in aparaturne (strojev) in inženirne
aparator, spec. materialov in kemikalij sa okroglo 20.000.- \$,
ki bi se razdelili nekako takole:

Amerika	5.000.- \$
Anglija, angl. fantov sa	2.000.- \$
Češka, KČS sa	1.000.- \$
Holandaka, hol. forinstov sa	1.000.- \$
Nemčija	3.000.- \$
Švica, Švic. frankov	4.000.- \$
Italija* lir sa	2.000.- \$
Ostaka, zad. forinst. sa	2.000.- \$

1. Oddelki in laboratoriji fizikalnih inženirnih delovnih skupin
ad. list

1. Oddelki in laboratoriji fizikalnih inženirnih delovnih skupin

1. Oddelki in laboratoriji fizikalnih inženirnih delovnih skupin
ad. list

2. Oddelki in laboratoriji fizikalnih inženirnih delovnih skupin

2. Oddelki in laboratoriji fizikalnih inženirnih delovnih skupin
ad. list

3. Oddelki in laboratoriji fizikalnih inženirnih delovnih skupin

3. Oddelki in laboratoriji fizikalnih inženirnih delovnih skupin
ad. list

4. Oddelki in laboratoriji fizikalnih inženirnih delovnih skupin

4. Oddelki in laboratoriji fizikalnih inženirnih delovnih skupin
ad. list

to je, kar bi
na območju
na "fiziki"
na območju

Figure 30-24: The fourth page of typescript of Peterlin's proposal given to Kidrič for the internal organization of the SASA Physical Institute in August 1948 with X-ray devices and vacuum pumps (ARS, AS, box 1, map 1).

Figure 30-26: The second page of the manuscript of Peterlin's proposal to Kidrič for the internal organization of the Physical Institute of the SAZU on 15 December 1948 with macromolecules, X-ray devices and vacuum pumps (ARS, AS, box 1, map 1).

1. Oddelki in laboratoriji fizikalnih inženirnih delovnih skupin
ad. list

1. Oddelki in laboratoriji fizikalnih inženirnih delovnih skupin

1. Oddelki in laboratoriji fizikalnih inženirnih delovnih skupin
ad. list

2. Oddelki in laboratoriji fizikalnih inženirnih delovnih skupin

2. Oddelki in laboratoriji fizikalnih inženirnih delovnih skupin
ad. list

3. Oddelki in laboratoriji fizikalnih inženirnih delovnih skupin

3. Oddelki in laboratoriji fizikalnih inženirnih delovnih skupin
ad. list

4. Oddelki in laboratoriji fizikalnih inženirnih delovnih skupin

4. Oddelki in laboratoriji fizikalnih inženirnih delovnih skupin
ad. list

5. Oddelki in laboratoriji fizikalnih inženirnih delovnih skupin

5. Oddelki in laboratoriji fizikalnih inženirnih delovnih skupin
ad. list

Figure 30-25: The first page of the Peterlin manuscript of his proposed internal organization of the Physical Institute of the SAZU delivered to Kidrič on 15. 12. 1948. In his paragraph »X 1. b)" Peterlin listed the vacuum pumps in the same way as in August 1948 (ARS, AS, Box 1, Map 1)

1. Oddelki in laboratoriji fizikalnih inženirnih delovnih skupin
ad. list

1. Oddelki in laboratoriji fizikalnih inženirnih delovnih skupin

1. Oddelki in laboratoriji fizikalnih inženirnih delovnih skupin
ad. list

2. Oddelki in laboratoriji fizikalnih inženirnih delovnih skupin

2. Oddelki in laboratoriji fizikalnih inženirnih delovnih skupin
ad. list

3. Oddelki in laboratoriji fizikalnih inženirnih delovnih skupin

3. Oddelki in laboratoriji fizikalnih inženirnih delovnih skupin
ad. list

4. Oddelki in laboratoriji fizikalnih inženirnih delovnih skupin

4. Oddelki in laboratoriji fizikalnih inženirnih delovnih skupin
ad. list

5. Oddelki in laboratoriji fizikalnih inženirnih delovnih skupin

5. Oddelki in laboratoriji fizikalnih inženirnih delovnih skupin
ad. list

na oddelku I. s delavnice potrebuje v letu 1949. za svojo
izgradnjo (le del tu naštetega načrta) poleg dena v Jugosla-
viji dosegljivih evrov in aparaturne (strojev) in inženirne
aparator, spec. materialov in kemikalij sa okroglo 20.000.- \$,
ki bi se razdelili nekako takole:

Amerika	5.000.- \$
Anglija	2.000.- \$
Češka	1.000.- \$
Holandaka	1.000.- \$
Nemčija	3.000.- \$
Švica	4.000.- \$
Italija*	2.000.- \$
Ostaka	2.000.- \$

Figure 30-27: The third page of the manuscript of Peterlin's proposal to Kidrič for the internal organization of the Institute of Physics Academy on 15. 12. 1948 with workshops and macromolecules in Section II (ARS, AS, box 1, folder 1).

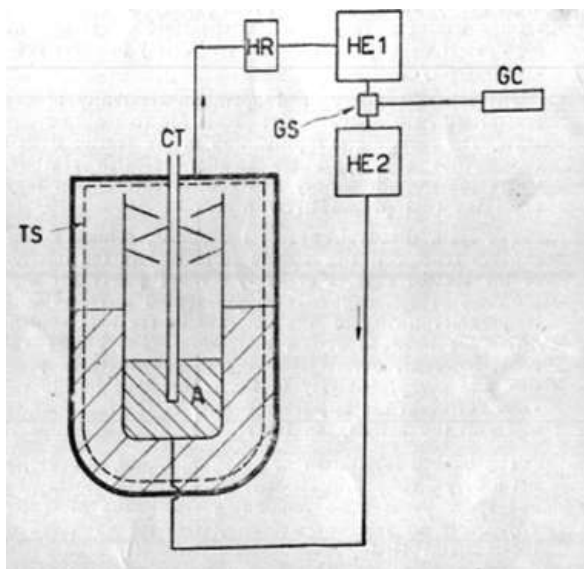

Figure 30-33: Peterlin's sketch homogeneous reactor with active core marked with "A" which he wanted to have in Slovenia (Peterlin, 1956 Boyling, 21)

of various experts including chemists, physicists and electro-technicians.

30.1.4.10 New Materials and Vacuum Techniques for a Homogeneous Reactor

The fundamental problem of Peterlin's homogeneous reactor was to prevent the corrosion of the reactor vessel withstanding extremely high pressures, which at the same time should pass through enough neutrons. The titanium, zirconium, or ruthenium had the first two advantages, but they absorbed too many neutrons. That is why Peterlin conceived two walls of the vessel, one of which had the appropriate chemical characteristics and the other provided desired nuclear properties. Of course, the volume of the reactor was proportional to the maximum of the usable electrons, so it was necessary to use heavy water instead of plain water. Peterlin listed twelve advantages of a homogeneous reactor, including safety, and only one disadvantage associated with spontaneous bubble blistering. Peterlin's idea of two walls was not particularly successful after a similar problem was raised in fusion reactors. For this reason, the Navy's Solid-State Ion bombarding team was included in the group of M. Kaminsky (Kaminski) within the Argonne National Laboratory in Chicago under the research entitled "Study of erosion and capture of light ions in the surface of first-surface materials". For research, the IJS built a low-energy accelerometer with double magnetic

ion beam focusing needed to investigate the AISI 316 L, Inconel 600 and 625 steel which were then used in chambers of all (experimental) reactors for nuclear fusion.³³⁷¹ Thus, Peterlin's Ljubljana thoughts designed in 1950s remained important for decades afterwards. His computations of the preventions against corrosion of the reactor vessel influenced his calculation of the persistent length of the DNA molecule including its elastic constants which he sent from Ljubljana to the Nature magazine on June 5, 1952; it became extremely interesting only in the times of Peterlin's death.

30.1.4.11 Conclusion

Kraigher and Ranković's dealing with Peterlin's heritage went through two phases. They first replaced him with physicists from a neighboring building on the Jadranska street no. 19, who extremely clumsily took over the power at the IJS with the help of reactor operators. This was only a maneuver that was intended to conceal the actual takeover of power by the ZKJ, which took over the director's chair, the chairman of the Expert Committee and the Scientific Council of the IJS after the new year of 1963.

Peterlin marked the beginning of modern physics in Ljubljana in the best possible usable way. The "gift" that was arranged for him at his meeting with Abraham was perhaps not the most pleasant one, but Peterlin in the US opened the new world horizons as no other Slovenian scientist before him.

30.2 Vacuum for Modern Slovenes

30.2.1 Vacuum at the Time of Director Osredkar and Vacuum Techniques in the Nuclear Magnetic Resonance of Robert Blinc (*1933; †2011)

30.2.1.1 Introduction

Tesla was a gifted inventor without a real talent for making money while his younger contemporary

³³⁷¹ Navinšek, 2000, 162.

Milan Osredkar (* 19th October 1919 Ljubljana; † 2003) was completely different; he was perhaps the best among Slovene physicists of the recent past, who has a top knowledge of nuclear technologies with the capability of their practical moneymaking realization in Slovenia. He was able to gather around him the capable talented experts, who upgraded Peterlin's justification of the Jožef Stefan Institute (IJS) in a way that still binds Slovenians to this day.

30.2.1.2 Osredkar and Peterlin

From 1931 to 1938 Osredkar was attending the first national real gymnasium in Ljubljana. Between 1938 and 1941 he studied electrical engineering. By the end of 1940, he completed the first part of the preparatory exams and at the same time he regularly studied at the Academy of Music. In the summer of 1941, he interrupted his studies for cooperation with the Radio Kričač of OF. A few weeks after the end of Kričač's broadcasts, in May 1942 the Italians captured Osredkar and sent him to Gonars after two weeks in prison; there he met the physicist Anton Moljk, who, after the war in Ljubljana, began the vacuum measuring techniques of nuclear radiation.

The capitulation of Italy enabled Osredkar to join the Partisans. After liberation, he remained in the Yugoslav National Army as a major UDBA. From 1946 to April 1948 he worked in Austria. Immediately after the war and again at the time of the Cominform (Informbiro) quarrels, Osredkar rescued from the prison the father of the Slovenian nuclear reactors Milan Čopič, when Čopič did not find himself in the promising position among various orthodox opinions on Stalin's person while returning from his studies in the Soviet Union.

In the autumn of 1948, Osredkar became the commander of the SUZUP (Service for the Protection of the Constitutional Order) in Ljubljana, and in 1952 he transferred to the later IJS as Peterlin's assistant administrator of the Institute.

At the beginning of his work in 1950, he began his studies again, this time in technical physics, which in Ljubljana of that time offered the best insight into the new achievements of vacuum techniques. On February 10, 1954 he graduated in Peterlin's class at the Department of Physics inside the Department of Chemistry of Technical Faculty of the University of Ljubljana. For his diploma Osredkar measured the strengths, time and spatial distribution of gamma radiation in the betatron vacuum with the counter of Cherenkov. Pavel Alekseevich Cherenkov (* 1904; † 1990) won a third part of the Nobel Prize three years after Osredkar's graduation, although Cherenkov saw the blue shine already in glass-bottled water exposed to radioactive radiation during his work with Sergei Vavilov in 1934. Cherenkov studied that remarkable phenomenon for six years.

The year before Osredkar's diploma, Darko Jamnik, the professor of the writer of this book, took the leadership of the beta-throne at the Institute. The institute was named after Jožef Stefan on Prešeren's day in 1953. After short practical training in Switzerland, Jamnik participated in the installation of Brown-Boveri betatron, which he bought in the summer of 1954 for the Jožef Stefan Institute. Osredkar knew how to perform his measurements at home; he helped to ensure that Jamnik succeeded in achieving the stabilization of the betatron at 5 keV for 20 MeV energy in 1956. Thus, a betatron at the IJS in the range of energies of up to 30 MeV became the most accurate device for investigating the nuclear

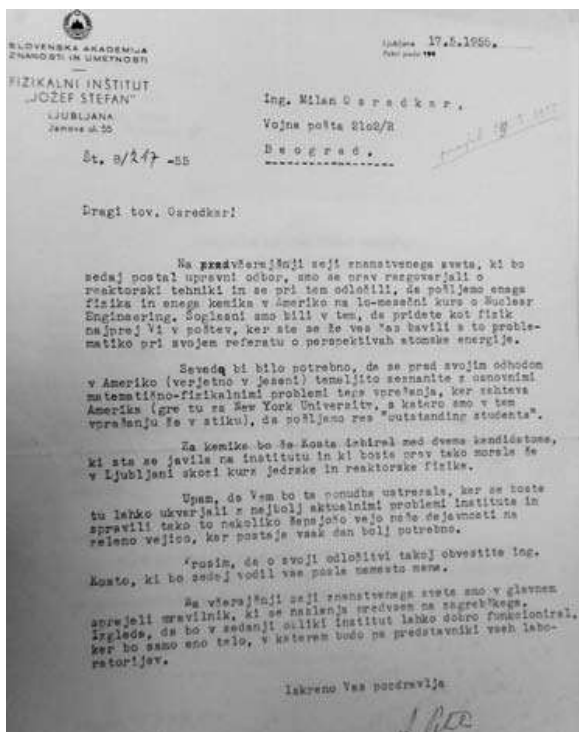

Figure 30-34: Peterlin offers to Osredkar the American engineering studies of American Reactor Engineering in his letter mailed from the USA on May 17, 1955 (Author's archive).

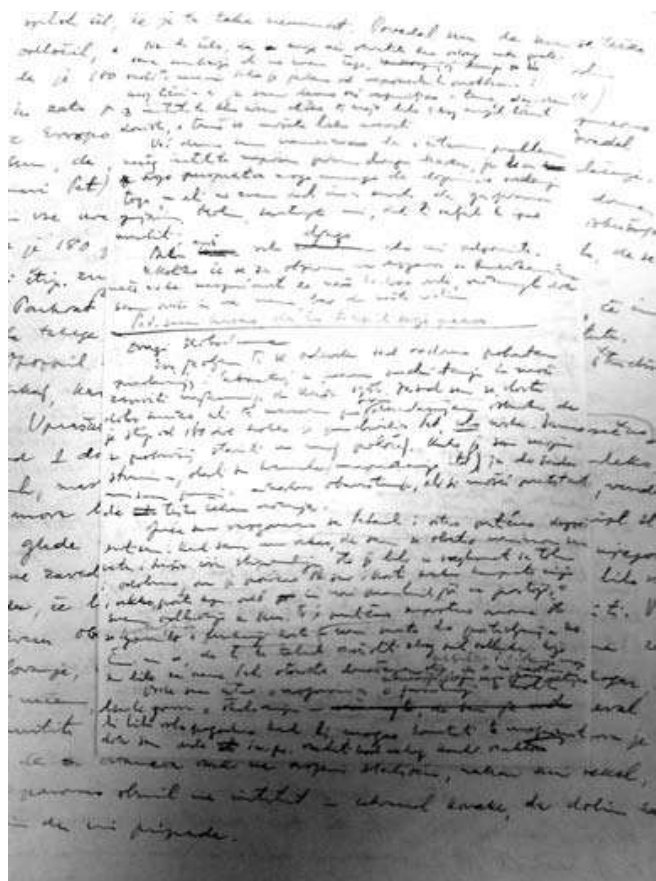

Figure 30-39: From the United States Osredkar reports to Peterlin about his US talks on November 5, 1955 (Archive Južnič).

On 1 January 1955, Osredkar started working at the IJS after the termination of his job at the SUZUP. His bride Uči Fajgelj (* 31st August 1927 Kred by Kobarid) was a graduate at the Faculty of Chemistry in 1955 and gained the title of engineer. In September 1955, after Peterlin's mediation, Osredkar traveled to the Department of Nuclear Engineering at the University of New York. There he became acquainted with modern vacuum and nuclear technology and got the prestigious title Master of Nuclear Engineering in 1956.

At his Inside-out Reactor study Osredkar looked at the specific distribution of the internal reflector and absorbers to increase thermal flux compared to that of ordinary nuclear reactors at the time. In December 1956 he reported on his research at a meeting in Boston; he published the paper in the prestigious Journal of Nuclear Energy along with his American supervisor and soon also his friend Richard (Dick) Stephenson. In the period 1956-1958, they published three papers, and Osredkar himself also published independently. Osredkar then calculated the relationship between flux and power in real reactors, which he intended to set up

in Yugoslavia. On 22 February 1957, Peterlin and Moljk proposed Osredkar as a scientific assistant to the IJS, where he was chief of the reactor group between 1956 and 1958; with his American insights and knowledge of modern vacuum techniques, Osredkar replaced the previously unique professor of nuclear physics in Ljubljana Franjo I. Havliček (* 3. 12. 1906 Moravska Ostrava). After returning from a prolonged two-year stay in the United States and a shorter visit to the Swiss Vacuum and Nuclear Capabilities Osredkar got his Ph.D. at Peterlin's class. Osredkar's 211-page long dissertation, dated August 4, 1958, was titled The Research of the Possibilities for Increasing the Thermal Flux in the Moderator Cavity Reactor as a continuation of his American research, adapted for the possibilities of vacuum nuclear technology in the domestic Ljubljana circumstances. Osredkar defended his doctorate about five months after Anton Moljk as one of the last of Peterlin's students in the Jožef Stefan Institute. After the defence, Peterlin sceptically asked Osredkar what could be the use of that type of reactor as none of them expected that the Americans and Soviets will soon really build it. Milan Osredkar was promoted on June 27, 1959,³³⁷² when he and his family already moved to Vienna. Immediately after submitting and defending the dissertation, Osredkar again went to neighbouring Austria. Between September 1958 and 1961, under the command of the ZKNE (Federal Nuclear Energy Commission), he worked in the Viennese IAEA Reactor Department. He thus diplomatically avoided complications around Peterlin's humiliations in Ljubljana, likewise as a year older Ivan Kuščer (* 17 June 1918 Vienna-† 2000).

30.2.1.3 Returning of Osredkar to the Rudder of the Jožef Stefan Institute

At the Faculty of Mining, Metallurgy and Chemical Technology Osredkar has been teaching the subject Encyclopaedia of Nuclear Engineering and Nuclear Materials since 1961, after applying from Vienna as the only candidate on 8 February 1960. On 8 September 1962, he was elected as Associate Professor in Ljubljana; he completed his work on the nuclear power plant and projected and submitted it to the Viennese International Atomic Energy Agency.

³³⁷² Kokole, 1969, 61.

From 1 January 1963 to 8 April 1975, Osredkar was the Director and Scientific Adviser of the IJS; he proved to be an extremely imaginative and effective negotiator with foreign partners with an enviable knowledge of English and German language.

In 1963, as the new director of the IJS, Osredkar immediately renewed contacts with Peterlin, who then extensively lectured in Slovenia, and especially at the IJS. Osredkar's management of the IJS enabled the breakthrough in the development of the Ljubljana-based thin-films protective layers. Precisely upon Osredkar's takeover of the director's chair, prof. dr. Boris Navinšek began to develop first simple "table" device for ion bombarding and ion etching. In the next half of the century, thin-layer vacuum technology became the pride of the applied science of the IJS, which is in many ways Osredkar's merit in the time before Navinšek recruited his successor, Peter Panjan.

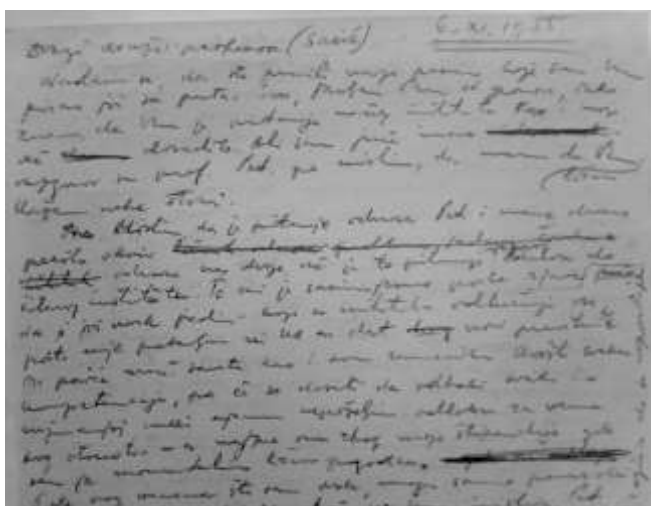

Figure 30-40: Osredkar writes from New York to the director of Belgrade-based Reactor Center in Vinča named after Boris Kidrič. The director Pavle Savić (* 1909; † 1994) worked with the couple Joliot-Curie during his Paris research on the effects of neutrons of heavy elements. Savić was nominated for the Nobel Prize at the side of Irène Joliot-Curie, and during the war he was distinguished as the Tito's Code manager. Among the Slovenes, he was not overly popular, especially after the first fatal accident, which was he indirectly caused as a chief in Vinča.

After Osredkar's return from the Viennese IAEA, he revived work for the Slovenian nuclear reactor. The land near Gradaščica river opposite the IJS was occupied in the meantime, so they discussed

the nearby location of the existing buildings of the Faculty of Mathematics and Physics. Later the location at Podgorica prevailed as the most reliable static building land.³³⁷³

On 8 July 1959, ZKNE commanded an examination of the needs for the installation of a new reactor immediately after Peterlin's resignation. The IJS has appointed a special commission with Moljk, Šinkovec, Bremšak, Kosta, Kladnik, Lebez and Kuščer. They studied the necessary circumstances for the installation of the reactor. In March, April and May 1960 an overview of possible locations was carried out by a technical group composed of S. Zupan, engineer later head of Triga reactor Zdravko Gabrovšek, engineer Natan Bernot (1931 Ljubljana-2018) and B. Sotošek after comparing them to similar locations elsewhere in the world. In that time in Vienna Osredkar learned how to upgrade Slovenian capabilities with modern vacuum techniques.



Figure 30-41: On 26 June 1956, Peterlin recommended to Osredkar many journeys to the United States in favor of the international implementation of the Slovenian Physics.

After lengthy negotiations through Osredkar's IAEA, the Americans donated to the IJS fuel for

³³⁷³ Search for location for reactor (Archive IJS in Podgorica, box 326, map 578); Osredkar, 2000, 38–39; Dimic, 2000, 237.

the reactor in Podgorica; they even planned to shift the entire JS into Podgorica, which was left only on paper,³³⁷⁴ sadly or maybe fortunately.

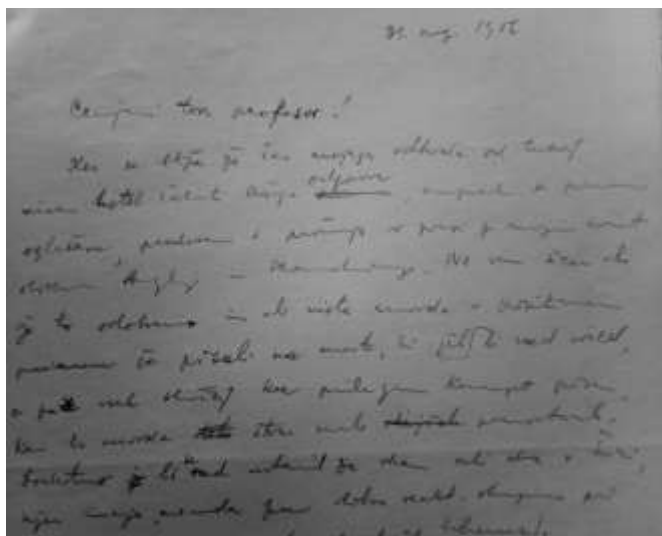

Figure 30-42: Osredkar writes to Peterlin just before his return from New York on August 31, 1956.

The construction of the Triga (Training, Research, Isotope, General Atomic) reactor in Podgorica started in May 1963, only a few months after Osredkar's takeover of the IJS leadership. At the end of Osredkar's mandate at the IJS, the foundation stone for the Nuclear Power Plant Krško (NEK) was laid on December 1, 1974, and construction work began in February 1975. Immediately afterwards, Osredkar completed his 12-year management of the IJS as a new member of the SRS Executive Council; there he took care that the Krško NEK was granted permission for regular operation in January 1984. Westinghouse donated NEK facilities parted among Slovenia and Croatia including Tesla's native Lika, maybe as a kind of compensation for Tesla's favors.

On 9 June 1967 the old Zagreb physicist Ivan Supek endorsed Osredkar's candidature. Supek was the only professor of the Experimental Physics and Reactors available for the University of Ljubljana. As Heisenberg's pre-war doctoral student Supek was proud of the fact that Osredkar asked for his opinion; Supek certainly did not explicitly support the research of nuclear technologies in fear of atomic bombs, but Supek nevertheless obviously highly appreciated Osredkar.

30.2.1.4 Vacuum Techniques for Nuclear Magnetic Resonance of Robert Blinc

On September 26, 2011, the academician Robert Blinc died several years after his mother passed away in a slight accident when Blinc drove his car into the fields near the Brnik airport. Blinc was certainly one of the most important Slovenian physicists of his time. I made my own first steps in the world of science under his supervising, so it is right to give him a short memorandum on this occasion. It seems that Professor Blinc in Slovenia was able to combine the novelties of experimental vacuum technique with an ingenious theoretical insight into the secrets of solid matter spiced up by the artificial use of scientific discoveries in the industry. Therefore, his work can certainly be an example to us.

Robert Blinc was born on 31 October 1933 as the nephew of chemist dr. Marta Blinc (1904-2000). Robert was a grandnephew of the wholesale merchant Robert Kollman (1872-1932) and the great grandson of the glassman Franz Kollman (1839-1908) from Begunje. The unmarried

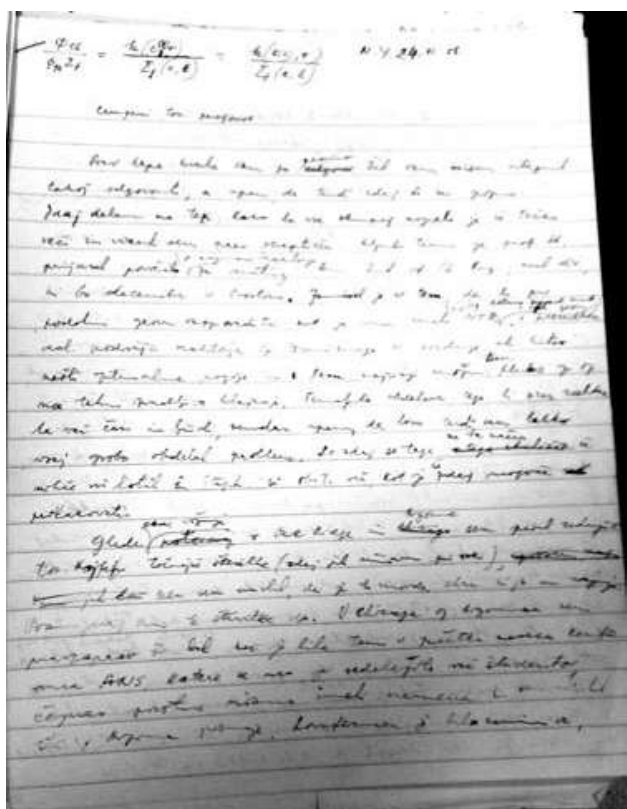

Figure 30-43: Osredkar reports to Peterlin from America on June 24, 1956. The top of the draft letter was decorated with equations describing the flow in the nuclear reactor.

³³⁷⁴ Osredkar, 2000, 30; note of the deceased dr. Matjaž Ravnik on 10. 1. 2007; Ravnik & Južnič, 2010, 185.

philanthrope Robert Kollman, among other things, owned the former Gruber's villa Podrožnik, which the older inhabitants of Ljubljana had long known as Kollman's castle. In 2015, the state officials put the memorial plate of Kollman there.

In gymnasium, the driver in nice official suit was always waiting for Robert Blinc to drive him home while his classmate Lado Rupnik (* 1934) sometimes got a lift. In Blinc's class were Jurij Kunaver (* 1933) the son of their professor of geography Pavel Kunaver, the future sociologist of migrations and great defender of classical studies Peter Klinar, later practitioner in Havliček's lab Anton Prelesnik, Stefan Slak and the future priest Alojzij Oražem. After his graduation with Matura at the classical gymnasium in Ljubljana, Blinc graduated in Anton Peterlin's class with the work Infrared spectra and the shape of the potential function of the hydrogen bond KH_2PO_4 and KD_2PO_4 in the non-ferroelectric and ferroelectric phase in 1957.

In the following year, Blinc prepared a doctoral dissertation on the Tunnel effect of protons in ferroelectrics with short hydrogen bonds on the eighty pages with graphical representations. In the head of the thesis Peterlin was noted. Peterlin may have participated in the defense on February 25, 1959, but Peterlin was certainly not present at the promotion on March 10, 1959, since he went to Mainz on 9. 3. 1959. Thus, final mentor of Blinc's work was Dušan Hadži, with whom Blinc submitted a report on "Hydrogen bonding studies" to the Slovenian Researchers' Society in 1957.

In 1957, Blinc published two papers in the IJS Reports, together with Jože Pahor and Edo Pirkmajer. In 1958, Blinc began publishing abroad, initially along with his aunt Marta Blinc or Hadži, but soon also alone as well. Already in 1958, Blinc published a brief report on hydrogen bonds in the leading Nature magazine in London, which greatly contributed to the international prestige of Slovenian researchers. The phase transitions soon became the basic direction of Blinc's research therefore it is precisely his early collaboration with the leading Slovenian chemists and an insight into the progress of the then vacuum technic which paved his way to outstanding discoveries.

Already before 1959, the physicists Ivan Zupančič (1930 Ljubljana-1999 Ljubljana), Blinc and

colleagues at the IJS built the first device for NMR in the former Yugoslavia, which was an exceptional achievement. Their success was also reported at the Bologna congress in the same year.

In 1960, the first son of Robert Blinc was born, who became the Doctor of medicine. The son Aleš was nice and when I met him for the first time in his father's office in IJS, he started to talk to me in English language. Aleš Blinc began his medicinal success by NMR studies of his fathers' lab to become the head of vascular diseases in UKC of Ljubljana and a businessman owner of the famous pub Maček in Ljubljana.

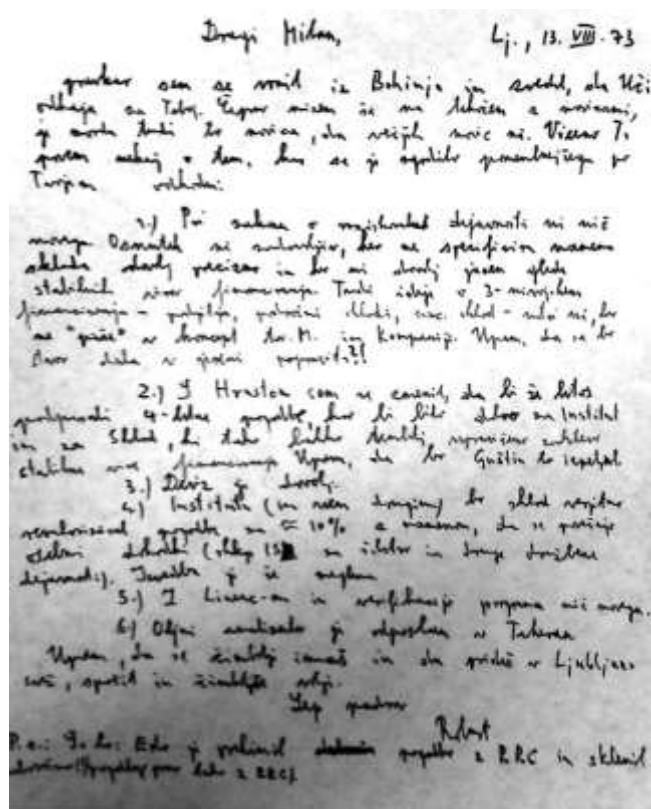

Figure 30-44: Robert Blinc's letter dated in Ljubljana on 13 August 1973, sent to IJS Director Milan Osredkar.

Blinc went on to postdoctoral training at MIT, where he became acquainted with the technique of magnetic pulse resonance. The tunnel model of ferroelectrics with hydrogen bonds explained the electrical properties of ferroelectrics and their changes when hydrogen is replaced by deuterium. In 1960 Robert Blinc became a docent, in 1965 he became an assistant professor and he was a full professor in 1969. On 17 October 1964, Blinc was elected chairman of the expert committee of the IJS according to Čopič's proposal. There Robert

Blinc chaired a total of sixteen meetings until 1 September 1965.³³⁷⁵

Blinc reported to Osredkar on events at the Jožef Stefan Institute, mostly on the agreement with Iskra electrical engineer Silvo Hrast (* 1921 Trieste-1999). Blinc noted the signing of a four-year contract between the IJS and the Fund of Boris Kidrič of Slovenia whose president was Hrast for eleven years. The contract was carried out by the director of Litostroj the mechanical engineering Božidar Guštin (* 1912; † 1984) the member of the Federal Nuclear Energy Commission in 1957. Hrast was a member and for a time also a president of the Kraigher's Steering Committee of the IJS in 1957. Hrast was even the technical director of Vinča institute from 1. 2. 1950 to 28. 2. 1952.

Under the sixth point, Blinc reported on the oil analyzer dispatched to Teheran. It was the NMR-analyzer of the oil and moisture content of grains of the agricultural crops, especially in the sunflowers. In the annotation Blinc reported on contracts signed by physicist dr. Edo Pirkmajer (* 1932) as the Secretary General of the Research Society of Slovenia and later Secretary of State (1996-2001), concluded with the Republican Computation Center (RRC). At first, RRC operated in the IJS frame in 1968 according to Južnič's Archive. The studies of phase transitions and liquid crystals were supported by new methods of microscopy and photography at the beginning of the 19th century. In the mid-20th century, the new discoveries demanded new methods of research. These were found mainly in the NMR, which was invented immediately after the Second World War and even included in Moljk's dissertation in 1956.

Already Stern and Rabi investigated the magnetic fields of nuclei in streams of atoms or gas molecules. Bloch developed a method for determining the magnetic field of nucleuses in liquids and solids at Stanford University. A slightly different method was discovered by Purcell at MIT in 1946, so the researcher shared the Nobel Prize for NMR development in 1952. In 1960, special serial publications devoted to NMR were also launched, among English-written mainly *Advances and Magnetic Resonance* in New York in 1965 and

NMR Basic Principles and Progress in Berlin in 1969. Soon after, periodicals and journals focused on NMR appeared, mostly *Journal of Magnetic Resonance* in New York in 1969 and *Nuclear Magnetic Resonance Spectrometry Abstracts* in London in 1971. With those journals, NMR became a separate field of research for half of a century, just like the ion implantation somewhat earlier.

The American **Edward Mills Purcell** was born in Illinois in 1912 and died in 1997. He graduated from Purdue University in 1933. After completing his studies in Germany, in 1938 he received his doctorate at Harvard, where he became a professor in 1948. Between 1940 and 1946 he studied at the MIT Laboratory for radiation. He also studied the spectroscopy of radio waves in astronomy. The Swiss born Jewish American Felix Bloch was born in Zurich in 1905, where he graduated as an engineer. He then went to Leipzig, where he became the very first Heisenberg's doctoral student in 1928 and received his first professorial post four years later. However, in the following year he left as he was afraid of Hitler's power. In 1934, he settled in the United States and taught at Stanford University, where he became a professor in 1936. Between 1942 and 1945 he worked at the Los Alamos Laboratory. In 1954 and 1955 he was the first general director of CERN. He died in 1983 in Zurich.

At the same time, with the introduction of the first magazines focused on NMR, the use of high-resolution NMR for the study of phase transitions at the IJS began when Blinc from the United States brought the first liquid crystals in the early 1960s. In Ljubljana even Doane learned about newly advanced approaches, and he was employed at the State University of Kent in 1965. That same year, the Ljubljana Blinc's Group got its second Kidrič Prize for researching liquid crystals.

In 1966, an international congress for magnetic resonances AMPERE was organized in Ljubljana, which was attended by leading scientists all over the world. International connections were strengthened, since Blinc also collaborated with then Harvard PhD student of electromagnetic fields

³³⁷⁵ Archive Of Republic Slovenia (ARS), SI_AS 1961 box 71, map 722; ARS, SI_AS 1961 box 72, map 723; Osredkar, Polnec, 2000, 314.

on the structure of liquid crystals. Robert Bruce Meyer (* 1943 Saint Louis) at ETH in Zurich. In 1986, they discovered polymerically distributed liquid crystals in which NMR proved particularly useful for studying the dynamics of molecules and phase transitions, although without distinguishing between thermotropic and lyotropic liquid crystals.³³⁷⁶ In 1974, Blinc and Boštjan Žekš published a remarkable monograph on ferroelectrics and antiferroelectric. The following year, the other R.J. Meyer and W.L. McMillan of Department of Physics and Materials Research Laboratory, University of Illinois in Urbana published the theory of the average field for smectic liquid crystals. In 1974 at Harvard Robert B. Meyer announced the possibility of ferroelectric liquid crystals which he during his Parisian sabbatical synthesized as DOBAMBC ferroelectric with the help of L. Liébert, L. Strzelecki and P. Keller at Université Paris-Sud, Physique des Solides Orsay in the next year 1975.

Robert B. Meyer received his master's degree and doctorate in 1970 at Harvard University. Later, at sabbatical he led a research team at ETH and at the South Parisian University³³⁷⁷ and became a professor of physics at Brandeis University, Waltham, Ma. USA.

In 1980, Noel Anthony Clark (* 1940 Cleveland) at the university of Colorado and Sven Torbjörn Lagerwall (* 1934) of Swedish college Chalmers discovered the technological significance of fast electro-optical switches from ferroelectric liquid crystals. Many studies followed in 1989 after the discovery of antiferroelectric and intermediate ferroelectric phases of liquid crystals of of Tokyo Institute of Technology graduate student A. Deebaram L. Chandani Perera from the Department of Chemistry in University of Peradeniya of Sri Lanka and her associates. By 1990, two hundred and fifty ferroelectrics were discovered, including fifty liquid crystals since 1984.

In 2000, Blinc's Ljubljana group focused their research on ferroelectrics and antiferroelectric exclusively favouring liquid crystals, thus rounding

of three decades of their previous research. The use of NMRs has enabled a very accurate monitoring of changes in the magnetic fields of molecules, especially water, with continuous and discontinuous changes in the structure of the substance. Blinc's department F5 was particularly successful in the study of disordered ferroelectric and antiferroelectric crystals, especially incommensurable systems in 1980s. Their solitons were discovered in the IJS and they proved the existence of phasic excitations. In the case of an incommensurable phase transition, a change in the size of the base cell can be observed at a longer temperature range, which occurs at a temperature point at ordinary transition.

The incommensurability extends the phase transition from narrow point to wide temperature range, even up to 111°C at Rb_2ZnCl_4 .³³⁷⁸ Stretching the phase transition gives a sense of the existence of a special intermediate state, like that of liquid crystals. An experiment with a stretched phase transition is like a microscope view. It reveals details to the variable structure of the observed object, which is not detected in ordinary passages at the temperature point. Similarly, a microscope reveals the components invisible to the naked eye. The telescope suddenly showed details at the surface of the moon to the fascinated Galileo, which were barely perceptible until then. Likewise, two centuries ago, Volta's discovery enabled the prolonged times for observations of electrical phenomena that occurred in the older experiments with the discharges of the Leiden bottle only in the instant. There might be a possibility that no phase transition never took place at the sharp constant temperature point as there is always some interval involved which makes incommensurable extension of the phase transition a general natural phenomenon like Faraday's diamagnetism. Such idea profoundly changes the present concept of point-like thermodynamic systems phase transitions at constant unchangeable temperatures just like the telescope transformed point-like stars into measurable objects. Even the linguistics might change from melting point to melting range, which could be as huge innovation as the Copernican motions of the Earth as it is already in use for industrial and educational purposes especially in compounds where the practical *melting (boiling) range* is defined as the

³³⁷⁶ Ding, 1994, VII, 1, 111-112.

³³⁷⁷ Lagerwall, 1999, 1-5, 405; Blinc, Žekš, 1974, 150; Čepič, 1998, 14; Muševič, Blinc, Žekš, 2000, XI, 1.

³³⁷⁸ Južnič, 1980, 29; Blinc, Žumer, Rutar, Seliger, Južnič, 1980, 610.

interval of temperatures from the *point* at which the crystals first begin to liquefy to the *point* at which the entire sample is liquid. The changed approach might even affect the phase transitions of non-thermodynamic systems, where temperature is not a parameter. Any experimental proof of the phase transition at ordinary temperature involving the incommensurable extension of that point into observable interval would be welcomed as it makes experiments cheaper without any liquid helium needed for cooling. The industrial application of relatively stable incommensurable phase at broad higher temperature interval could emerge considering its strange peculiarities and funny fact that Thomas Kuhn used the same term incommensurability.

The discoverer of the Solitons, Scott **Russell** (* 1808; † 1882), studied at universities in Edinburgh, Glasgow and Saint Andrews. In 1832/33 he received natural science lectures at the University of Edinburgh after the death of John Leslie (* 1766; † 1832) who used to be one of the most prominent advocates of Bošković's physics. Later, the Union Canal Company explored steamboat navigation along the canal between Edinburgh and Glasgow. In 1838 Russell first noticed the soliton there, which he described six years later. The phenomenon was called a "wave of translation". He also noticed that after the meeting-collision the solitons switched over each other without any special changes, which, when rediscovered 130 years later, delighted the researchers. However, in his time of dominance of wave theory, Russell could not see the similarity between the soliton and the particle while particles gained momentum in Britain only few decades later. He later used his observations in the construction of ships.

The Scotsman Russell's discovery was not widely noticed on the European continent. It was criticized by Russell's British compatriots the astronomer George Biddel Eary (* 1801; † 1892) and the leading British hydrodynamic expert George Gabriel Stokes (* 1819; † 1903) who did not believe in the existence of a soliton. Although Descartes's vortex theory in the 19th century, despite Newton's criticism, developed strongly in works of Ampère, Faraday, Maxwell, and Helmholtz, it was necessary to wait until the systematic theory of nonlinear fluctuations and

waves. Only then the theory of solitons in a vacuum developed in the second half of the 20th century.

Upon returning from his two-year stay in India at the thin films department of the University of Sri Venkateswara, Tirupati, and at the Indian Institute of Science in Bangalore, the professor dr. Jože Gasperič was employed in Blinc's department in 1987/88. Blinc used the skills of his several months older classmate from a classical gymnasium in Ljubljana, professor dr. Jože Gasperič, the leading Slovenian expert in vacuum technology.³³⁷⁹ Thus, the advancement of modern vacuum techniques in the solid matter research section gained momentum, and as a collaborator of Blinc's laboratories, Gasperič became exceptionally well established as the organizer of the DVTS activity.

30.2.1.5 Conclusions

Osredkar built his career as a partisan. He had been decorated in 1941 mainly for technical and project work for the radio Kričič. On 25 April 1946, he received a medal for his meritorious deed for the nation. On December 20, 1951 he got the decoration for courage and the decoration of fraternity and unity, in 1965 he was awarded a medal of the work with the flag, and by the order of the president on 16 November 1967 he received the following year the order of fraternity and unity with a golden wreath for the introduction of the radio transmitter Kričič.³³⁸⁰ In 2001, he somewhat postponed the celebrations of his eightieth birthday with the receipt of the golden honorary sign of the freedom of the Republic of Slovenia. His staying in the US and Austria was of key importance for the Osredkar's cosmopolitan scientific path, closely linked with the introduction of modern vacuum techniques to the IJS.

Blinc, was a descendant of one of the richest families in Ljubljana, but Robert Blinc was able to adapt to the Partisan authorities with the Osredkar included. Blinc was the dean of FNT and head of the Research Society of Slovenia, longtime vice president of the SAZU (October 1980 - May 6, 1999) and in December 2007 the winner of the golden mark of the IJS for outstanding merits in the establishment, development and operation of

³³⁷⁹ Jenko, 1997, 30; Pregelj, Zalar, 2002, 27

³³⁸⁰ M. Osredkar's personal map (Archive IJS in Podgorica).

Jožef Stefan International Postgraduate School. On November 24, 2008, he received the Zois Prize for the year 2008 for lifetime work in the field of solid matter physics. The academician Robert Blinc raised his entire generation of influential scientists in his famous F5 section at the Jožef Stefan Institute. He had an exceptional gift for international cooperation: many foreigners who were visiting F5 could praise the extremely modern laboratory equipment, compiled according to the latest achievements of vacuum technology. On the other hand, they admired the fuel economy in F5, which was merely indicated by a small beauty error: the electric lights were always lit. Professor Blinc wandered through the F5 laboratories every morning and participated in a traditional tea party. His walk among colleagues was very like Ernest Rutherford's behavior at Cavendish's laboratories. Both were able to show to all colleagues that they were interested in their work, but at the same time they expected the soonest results and publications. Naturally, Rutherford liked to exaggerate, because in such a large laboratory he no longer knew all his subordinates. So, one afternoon, a nervous plumber broke into Rutherford's secretary's rooms and demanded the termination of the contract by which he was supposed to repair the water supply system in Cavendish labs. The surprised secretary asked him: "What's up?" The plumber-man refused to finish his job: "You know, during my morning work, I was struck by a high-pitched man who jelled on me few times why I didn't finish my measurement and when will I publish my results!"

We once warned the cleaner from the South Yugoslavian areas named Bosiljka that she must get her wristwatch away during cleaning around a strong NMR magnet in section F5, because otherwise her watch might be magnetized and therefore would not show the right time in the future. When we met her the next day we chattered, did she act according to our instructions? She proudly assured us: "Of course, I kept my watch in my pocket when I was cleaning around the magnet!"

In F5 Blinc also employed the expert for EPR and liquid crystals Marjeta Šentjurc (* 1940 Hrastnik), the daughter of leading communists Lidija Šentjurc (* 1911) and Boris Kraigher's first cousin Sergej Kraigher. That was one of the ways for Blinc's success to avoid the sufferings of his aunt Majda

and Robert's grandmother after WW2. Blinc taught me how to find the references in the literature and how to cite them, and even showed me full packet of his refused papers so I learned that even he is not successful all the time. He was always taking and forgetting his pencils during his rides in F5 lab which put his own smell everywhere.

I enjoyed everyday tea parties at 10 o'clock where we talked mostly about sailing and the sailors' knots in F5. Once Blinc accompanied the Russian professor there and introduced me as an expert on Russian incommensurability studies because I just found the fundamental new book about that in DZS library in Ljubljana. I was so proud that I was hardly able to answer the question of the Russian even if I learned Russian well recently in Minsk. Once me, Blinc and another Russian professor were standing on the stairs of the university physics department and the worldwide leading expert for computer simulation of chemical structures Milan Hodošek run upstairs nearby barefoot with a slight short salute. The Russian looked at Milan's barefoot legs all the way upstairs and then declared deeply astonished: "With us at Lomonosov (university) that would not be possible (у нас на Ломоносове это невозможно)." Me and Blinc just smiled because we knew that Milan is a great guy.

Vinko Rutar was among the best Blinc's collaborators and loved to wear the white laboratory suit just as Blinc did, while the others avoided that habit. Later Vinko became the Director of Quality of energy absorption Systems, Inc. in Chicago. Blinc was always wondering how Vinko knows so much about laws until Blinc find out: "I see, your wife studied law!"

Blinc also lectured in general theory of relativity for us students of the last class before graduating, although he usually entered his classroom unprepared. Once during the break, he stopped me with a big book in my hand. When he discovered that it was Robert Merton's sociology of science book, he was not entirely happy, but anyway started to narrate how he was in West Coast of USA at Berkeley during the students' revolts in late 1960s. Blinc loved to talk about his many travels especially to Brazil where he weighted himself and measured out that he gained so many kilos. His friends then told him that the weighting

there gave some extra heaviness because of the big nearby mountain full of iron ore.

When the Brazilians returned their visit to Ljubljana, Blinc offered them the machine for counting the votes in polls. The Brazilians smiled and refused as they say that their political system was just like the Yugoslavian system and there is no urgent need to count the votes as the winner is known in advance anyway.

30.2.2 Honorable Professor Janez Strnad

30.2.2.1 Introduction

Blinc's university classmate Janez Strnad, despite their joint research efforts at the IJS, went to the completely different unconnected ways of research. Robert was often a foreign critic of Strnad's way for absolute devotion to the teaching only. I agreed with Robert on that point.

30.2.2.2 Study and Research Work

Janez Strnad (1934 Ljubljana-2015) was among the best students of Anton Kuhelj (* 11 November 1902 Opčine in Municipality of Trieste; † 31 July 1980, Ljubljana); the legend says that A. Kuhelj's classes of mechanics did not even get anywhere if Strnad was not in the first benches of Kuhelj's lecture room.

Strnad graduated in 1957 under supervision of Professor Anton Peterlin. His graduate thesis (diploma) was the continuation of the diploma of another important writer of Slovene physical textbooks, Rudolf Kladnik (* 1933; † 1996). While Kladnik prepared for Peterlin a diploma on reactor physics with a work "Double-core conversion of reactor systems with a homogeneous nucleus," Strnad continued a year later with a similar work "Double-bulk approximation in neutron diffraction in a reflector."

In the same year when Strnad and Robert Blinc (* 1933; † 2011) graduated under supervision of the professor Peterlin, the physicist Jože Pahor also graduated, but he later researched in other fields. The following year, Peterlin has awarded a diploma to another prospective physicist, the future professor of physics Franc Cvelbar (* 1932). Cvelbar focused on the Transformation of a Neutron Generator and Calibration of Neutron

Crops. Nuclear physics was, for the most part, the only true path of Slovene physicists, although Peterlin and Blinc were both swimming against the stream into the solid matter physics.

Strnad received his doctorate on June 29, 1963/ 18 February 1964³³⁸¹ under supervision of the professor Bogdan Povh (* 20. 8. 1932, Belgrade) and under supervision of the associate professor at the Institute of Theoretical Physics of the Faculty of Science, Zagreb, Gajo Alaga (* 1924; † 1988); Marko Vakselj (* 1932) did the same.³³⁸² Strnad and Vakselj completed their doctorates after Osredkar took over the management of the IJS and contacted A. Peterlin in the US. Alaga was a student of Peterlin's friend Ivan Supek. After Peterlin's sudden departure, it was necessary for some time to look for supervisors for doctorates outside Slovenia, mainly in Zagreb.

Strnad measured the paramagnetic resonance on the IJS. He studied neutron diffusion, especially the theory of relativity and nuclear physics. He was trained in Heidelberg, where his supervisor B. Povh became a full professor on 8 December 1955. Later, Strnad frequently visited Giessen to research all about the teaching of physics and its history.

30.2.2.3 Teaching and History of Physics

For the purposes of his physical lectures, Strnad began to develop the history of physics, in which he focused primarily on the best Slovenian physicists, such as Jožef Stefan³³⁸³ or Anton Peterlin.³³⁸⁴ He helped a great deal in the dissertation on Graz professor of physics Simon Šubic. A large part of Strnad's several thousand published works goes back to the history of physics. The basic problem that interested Strnad and many others from his generation was the genesis of modern physics, which in the basic lines ended in the time of Strnad's birth but became the

³³⁸¹ Kokole, 1969, 61. In 1962 submitted typescript for the advisor Bogdan Povh, noted in the data of Faculty for physics in Ljubljana.

³³⁸² Unfinished Ph.D. with Anton Peterlin according to the data of his daughter Tanja Peterlin - Neumaier and Janez Strnad in 2006. But Kokole (1969, 60) did not note any limits of Peterlin as Ph.D. advisor.

³³⁸³ Strnad, 1996, 242.

³³⁸⁴ Strnad, 1979; Strnad, 1985.

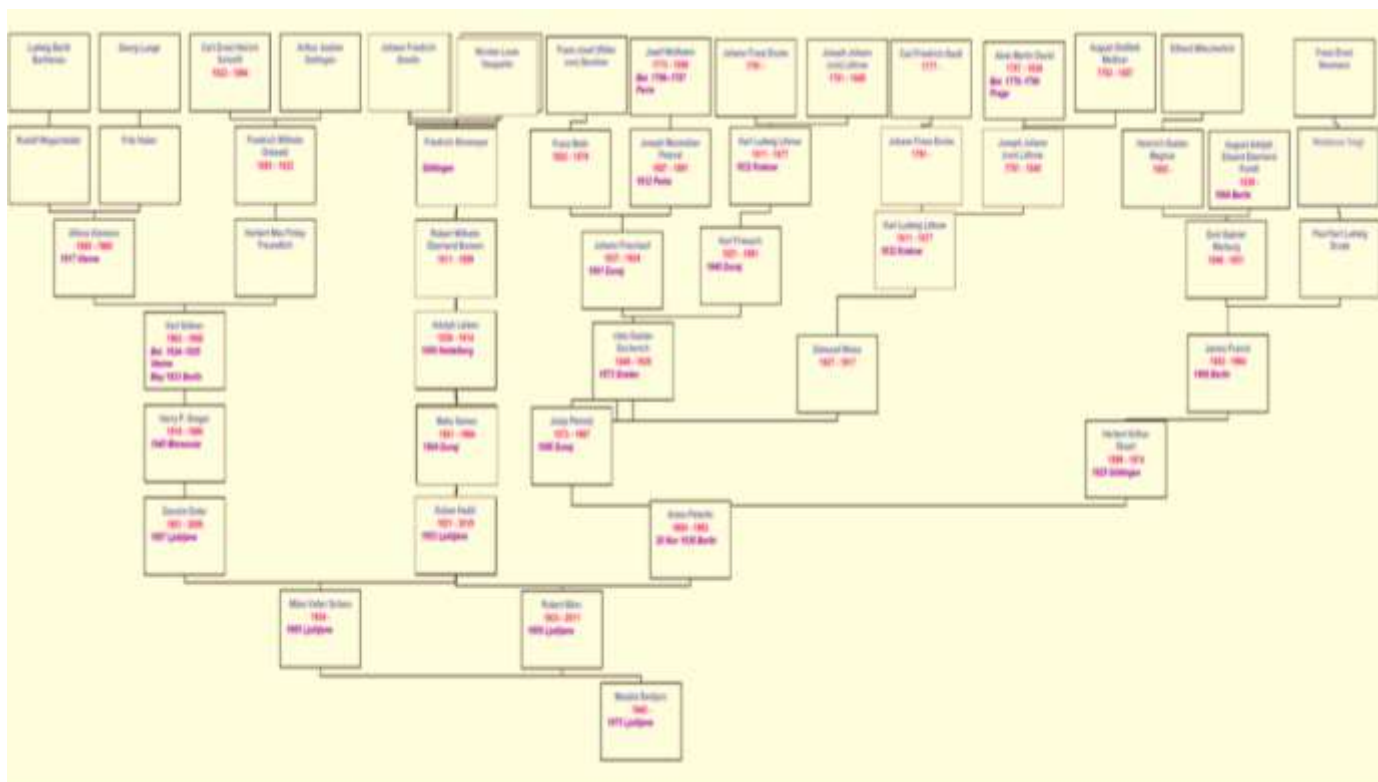

Figure 30-45: Academic ancestors of researcher of liquid crystals Marjeta Šentjurc including the Viennese expert of gas analysis, nitrochemistry and glow light electrolysis Alfonz Klemenc from Spodnja Šiška

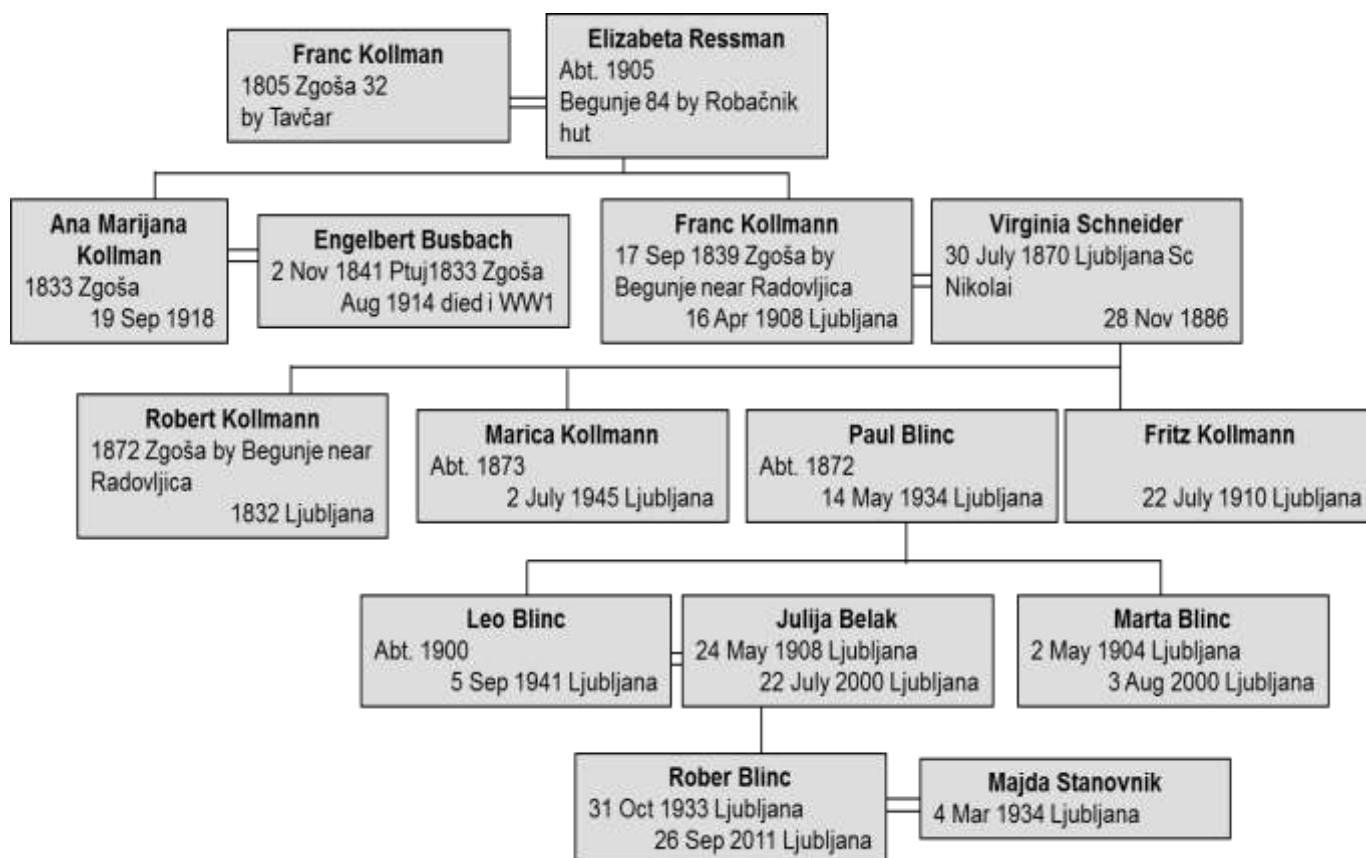

Figure 30-46: Blinc's family tree

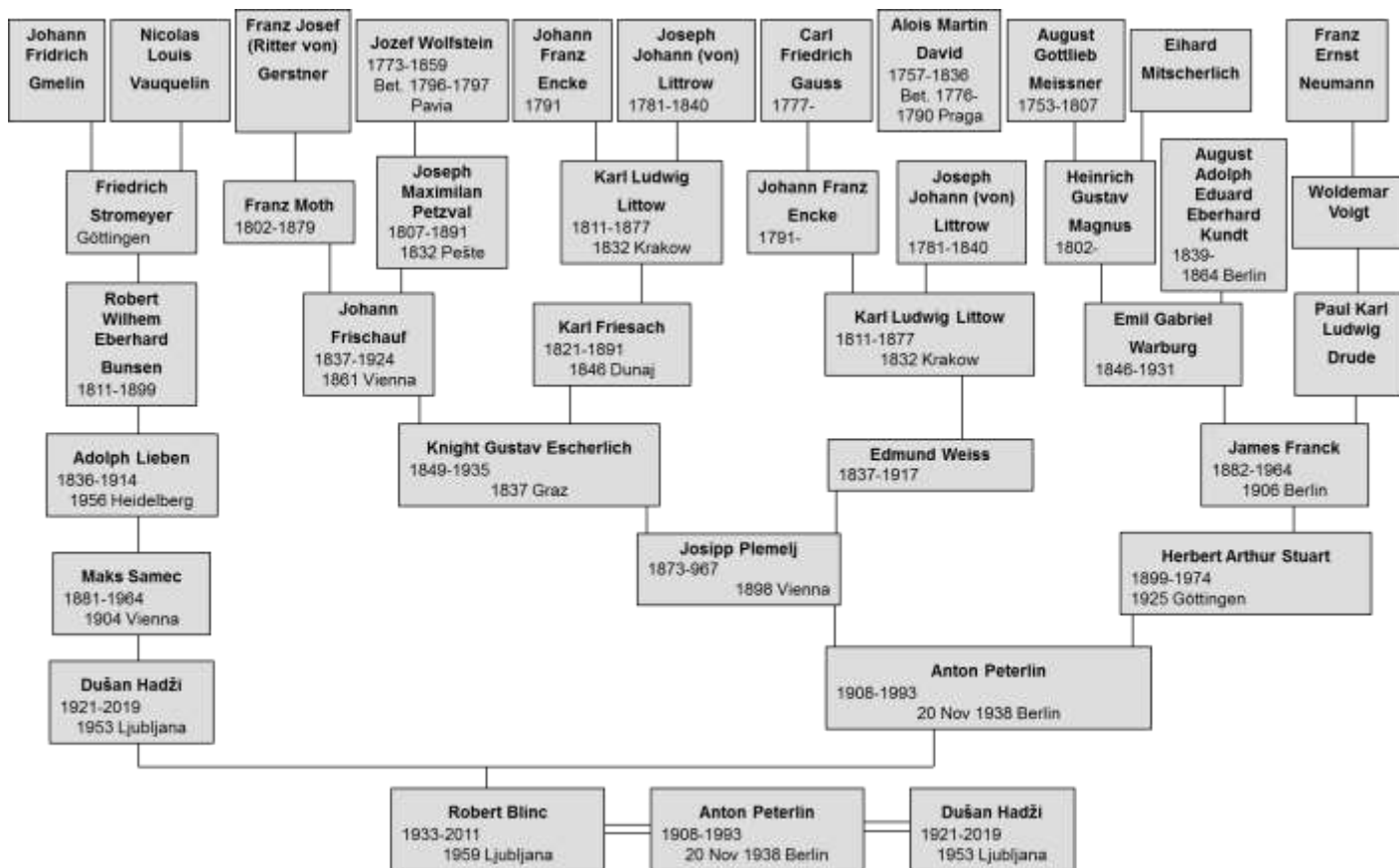

Figure 30-47: Blinc's academic ancestors

mainstream only after 1945 Japanese bombings. He correctly perceived the decisive importance of the rapid development of vacuum measuring techniques, especially Stefan's and other devices used for measuring the "black body" radiation in the decades before the First World War. He realized that top vacuum techniques had been the main incentive to develop often unusual achievements of the Copenhagen School of N. Bohr.

The professor Strnad described and drawn early vacuum experiments of Torricelli and Pascal.³³⁸⁵ He was interested in the vacuum techniques of Ernst Rutherford's associates in Manchester, including Hans Geiger and Ernest Marsden.³³⁸⁶ Among the rare experimental physicists in his opus, Professor Strnad studied in greater detail the work of American Leon Lederman (* 1920 New York; † 2018), who already in 1950 measured that many pions of the Synchrocyclotron of the Columbia University leave the vacuum container of the accelerator. Because of the magnetic field

³³⁸⁵ Strnad, 1996, 100–101.

³³⁸⁶ Strnad, 1996, 294–296.

they then rotate outside the vacuum along the accelerator.³³⁸⁷

Ivan Kuščer was always the main Strnad's supporter after Peterlin's departure; in his humorous manner, Kuščer was jealous at the extraordinary speed of Strnad's publication, which Kuščer himself could not master. Kuščer and Strnad successfully used Slovene physical terminology in their textbooks, and often also interfered with the field of vacuum techniques. They liked to join the students for mountain trips to Kofce and elsewhere, where we listened carefully to their first-class sharp-eyed teasers, which were often difficult to follow.

30.2.2.4 Conclusion

In his final works, Strnad produced many wirelessly broadcasted shows on eminent physicists and posthumously published a little booklet on Doppler, his best unique inventive case study, the nicest he ever made.

³³⁸⁷ Strnad, 1995, 145.

The honorable professor Janez Strnad is the iceberg of Slovenian history of physics. He also indicated many ways in the development of the use of vacuum measuring devices, especially for experiments that led to quantum mechanics.

30.2.3 *The Valley of the Upper Kolpa for Slovenian Vacuum Researchers Once and Today*

Strnad and Blinc were the teachers of us all. Numerous Slovenian and Croatian researchers of vacuum with their homes near Upper Kolpa river joined the 22nd meeting of Slovenian-Croatian vacuumists in Upper Kolpa valley of Osilnica in 2015. Among them Upper Kolpa experts are Janez Kovač (from Srobotnik), the first author of the Slovene post-war textbook about physics Franc Kvaternik (* 1919, Osilnica; † 1981), Matjaž Panjan and his uncle Peter Panjan (from Sodevci); their achievements were described by their neighbor from Fara by Kolpa river. An interesting fact of their success is explained by the extraordinary technical heritage of the inhabitants of the Upper Kolpa, which dates far back to the medieval mill used until 1651 for the processing of Carniolan iron ore by Count Petar Zrinski in Čabar. They exported the products through Bakar port. Andreas Kouach (Kovač, smith) was working there in 1672. As his surname indicates he was certainly something like a master blacksmith in Čabar areas.³³⁸⁸ Aleksander Vilhar (* 16 February 1814, Mountain (Planina) no. 74 by Rakek, 1868) and Wilhelm Vilhar were immigrants from the Slovene side in the 19th century. They were brothers of the famous poet and F. Levstik's friend Miroslav Vilhar (Wilicher, * 1818, Upper Mountain (Planina) no. 74; † 1871). At the Milan Summit (Vrh) between Čabar and Prezid they designed one of the first Croatian steam turbines worked using vacuum techniques in 1847/48. Aleksander's grandfather Dušan Vilhar, a friend of the Rijeka patriot Frano Supil, made a steam saw based on updated vacuum techniques in nearby Gerovo; the physicist Franc Kvaternik was growing up somewhat westwards by the Čabranka and Kolpa riverbanks at Osilnica where, of course, he learned all about that saw very well.

The work of Vilhar family in the Gorski Kotar and

³³⁸⁸ Andreas Kouach at the settlement of Czabar (Burič, 1983, 182).

the Maribor period (1878-1879) of the Military Krajina native Nikola Tesla were the first Croatian-Slovenian collaborations of vacuum techniques experts. Their 22nd meeting of Slovenian-Croatian vacuumists continues with their tradition. Tesla's transfer of the vacuum technique of from Karlovac (Rakovac) of Zagreb academician Martin Sekulić to Maribor finished infamously, although the urgently growing Maribor environment of those days had certainly affected Tesla's visions. Tesla coil and transformer, especially in the giant version at the Wardencllyffe tower, has increased Sekulić's Rakovac by Karlovac school-based laboratory models through Tesla's Maribor dreams about a free electric energy and similar necessities for everyone.

30.2.4 *Duncan Haldane's Eight Part of Slovenian Nobel Prize*

Duncan Haldane won the first eighth part of Nobel Prize for Slovenian physicists with his works related to Thin Film Research. The half Slovenian Duncan Haldane's topological research of electromagnetic properties of thin films are presently in focus. His approach might have some connections with his Slovenian heritage as he predicted the quantum computers' future.

The third try brings luck, they say. The third try has a charm. The Slovenian countries contributed to the three Nobel Prize winners: to the ancient Ljubljana born Fritz Pregl's prize for chemistry, to a part of the Nobel Peace Prize of Lučka Kafež-Bogataj, and recently, finally, to the quarter of the Nobel Prize of Duncan Haldane for physics and there is also Peter Handke who first spoke in Slovenian language during his Nobel prize ceremony. Each of these rewards is different, each covers different area. What did smart Duncan for such an honor?

Duncan's mother studied medicine in Vienna in 1942. There was not much help provided by her father Joseph Renko, brothers Franc (d. 1982), Pepi and Anton Renko (d. 1968) and sisters Alojzija Markič (Markitz, d. 1962) and Theresa Scheiber (d. 1998) or an uncle from Begunje in Upper Carniola Janez Renko with his daughter Jera Renko (* 14. 3. 1907) from Srednja vas (Central village) with the then valid number 2 between Begunje and Tržič. The old Slovenian proverb stated: When you go to Vienna, you leave your

stomach outside (because it's so expensive in Vienna). More help was provided by Ljudmila's wealthy grandfather the trader in Carinthia Čikov (Tschithekoff) and from her mother Alojzija from Borovlje who married in 1906.

The Borovlje based firearms manufacturing supported Ljudmila's decision for profession of treating wounds. The lost Slovenian Carinthian plebsite was among the reasons why the nationally aware Slovenian Ljudmila wished her son's name to be Dušan, the name of the greatest Serbian ruler of all times. With another son named John Stuart Haldane (6. 12. 1957-21. 8. 2000)Ljudmila did not have so many Slovenian second thoughts.

The teenager Duncan liked to go to Borovlje, where he learned German language as well as Slovenian language in the Inn Renko-Stiegler that still operates today on the main market No. 3.³³⁸⁹

30.2.4.1 Doctors for Thin Films

In Klagenfurt the young doctor Ljudmila helped the local wounded partisans together with her Scottish counterpart Frederick Paterson Haldane (24.5. 1912-15. 9. 1983) as a first-class basis for Duncan's London birth; Frederick was still married to Heulwen Morgan, who has given birth to their daughter Ana Haldane married Nuki (26. 6. 1936-2001) and to their son. Of course, in Klagenfurt Frederick was temporarily fascinated by the local Partisans, and even much more with the nice Carinthia native Ljudmila.

Duncan was a relative of celebrated Marxist Geneticist named John Burdon Sanderson Haldane (1892-1964). In 1924 he became famous after publication of his novel *Daedalus* with the first description of the birth of a man from a test tube as the ancestor of A. Huxley's *Brave New world* printed eight years later. The Slovenian thinkers used John Haldane as a role model with his research. He distinguished French theory of probability developed from gambling games, as opposed to English version of the same developed from insurance and the problematic O. Heaviside's *Genesis of Leibniz's operational calculus* developed for Maxwellian Electrical engineering in 1893. John was of course much more than just a

mere special guy; that's why in his last years the British archipelago became too tight for him and he preferred to move under the Himalaya.³³⁹⁰

John's heritage and a native medical family guided Duncan's fate when he decided between the early developed of string theory and the solid state physics of thin films; he soon realized that the chemical-medical experiments of his parents are not his own innate love. He opted for his research of the solid state of thin two-dimensional layers or one-dimensional chains of small-scale magnetic atoms under the supervising of just awarded Nobel prize winner the atheist Philip Warren Anderson (* 1923) rather than for then most popular one-dimensional strings.

Duncan's eternal inspiration was Anderson. Just like the other J.H. van Vleck's PhD student Thomas Kuhn, Anderson also deeply understood philosophy of learning with his interpretation of phenomena "more is different" of broken symmetry of emergence structures that develop properties completely foreign to their own ingredients, such as termites' mounds or Duncan's thin films. Not "more is better" of modern consumer society, but "more is different".

In 1977 Duncan's Cambridge Professor of physics Anderson earned his Nobel Prize in physics together with his teacher Van Vleck for their exploration of electromagnetic and unordered systems that soon enabled electronic switches and memory cells of computers. In the following year Duncan in his PhD thesis expanded Anderson model to the rare-earth elements with mixed valences.³³⁹¹

After his initial research of rare-earth elements which for most of his readers seemed too strange to be correct, Duncan began to explore Tomonaga-Luttinger's liquids used to describe the behavior of electrons in carbon nanotubes, or of any fermions in different quantum chains-threads. The model of Fermi liquids is apparently not usable for single-dimensional tubes; therefore, the son of Jewish

³³⁹⁰ Haldane John Burdon Sanderson. 1939. *The Marxist Philosophy and the Sciences*, Random House, Ayer Co. Translation: 1951. *Marxist philosophy and Science* (Marksistična filozofija in znanost). Chapter II. Ljubljana: Cankarjeva založba.

³³⁹¹ Haldane. An extension of the Anderson model as a model for the mixed Valence Rare Earth materials, Cambridge Ph.D. 1978.

³³⁸⁹ Peutz, Elisabeth. Ferlach freut sich über Nobelpreis. *Kleine Zeitung Kärnten*. 9th October 2016.

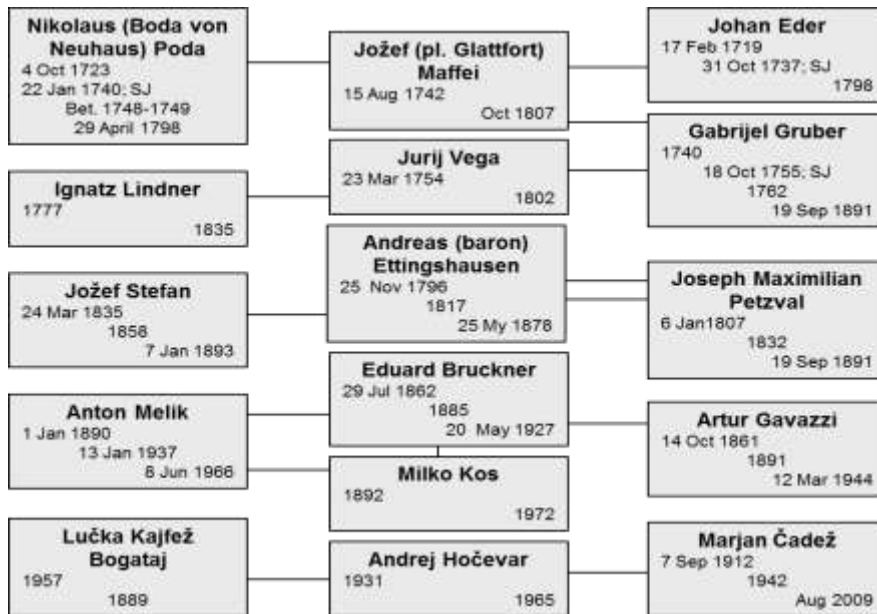

Figure 30-48: Academic ancestors of the first Slovenian winner of Nobel prize related to global warming Lučka Kajfež Bogataj all the way to Gruber and Vega

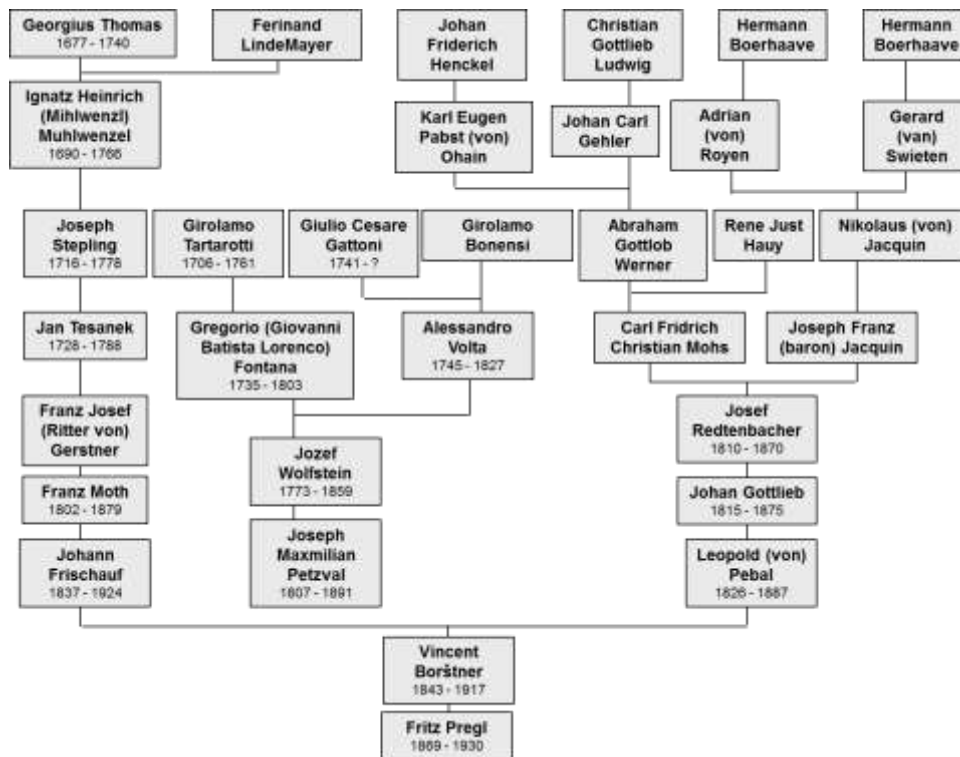

Figure 30-49: Pregl's academic ancestors according to his Ljubljana Professor Borštner, who also taught Pregl's junior Classmate Josip Plemelj (1873-1967). The family name Haldane was originally spelled Halfdane in the sense of a half-Dane due to the Danish Scandinavian Vikings, whose descendants settled in the Glasgow area before the millennium. Half-Dane would be the wrong mark today, because Haldane is half Slovenian. Duncan Haldane was in fact supposed to be Dušan by the original imagination of his mother, the Carinthian Slovene physician, Ljudmila Renko (Mila translated as People's pleasure, 24. 12.1919 Borovlje (Ferlach)-August 2016). Of course, her Scottish relatives pressed a little on the thirty-two-year-old mother and her small Slovene London oasis quickly surrendered. Duncan was very happy after that, because he avoided the jokes of fellow students with his better Londoner environment friendly name.



Figure 30-50: Duncan's grandfather Thomas Frederick Haldane (1839 Kran High Church Paisley Renfrew-1916 Paisley, Renfrewshire 10 km west of Glasgow near the airport) along with his younger brother Roberto (* 1841) headed the enterprise for drying of salts and chemical products as a good base for his offspring physicians and physics.

immigrants Joaquin Mazdak Luttinger (Quin, 1923 New York-1997) from Columbia University of New York described the low energy excitations of one-dimensional electron gas with bosons in 1963. He certificated the »plasmon« of David Bohm (1952) as wave-oscillation of the density of charge in the plasma of a gas of free electrons. Despite of Einstein's support, the left-winger David Bohm had

to live Princeton for Brazil, while his plasmons remained mainly at the Princeton anyway. In Fermi gas the plasmon behaves similarly to the photon in electromagnetic wave. Bohm's plasmon was created during the flooding of ideas focused on new quasiparticles which revitalized the old observations of solitons of John Scott Russell (1834), as well as new quasiparticles phasons in quasicrystals onboarded at phase transitions in incommensurable solids. The similar elementary particles had lost momentum of their prestige in

nuclear physics; therefore, they were soon replaced by quarks from the imaginative book of the Irish Trieste immigrant James Joyce, while the quasiparticles established themselves relatively a lot deeper into their much more hospitable physics of solid state.



Figure 30-51: Duncan's great-grandmother Euphemia Bell (b. 1851) married Haldane at her wedding day on 6. 7. 1876 in Glasgow; Duncan, like his supervisor Anderson, worked for some time in the Bell labs of his distant cousin, American inventor of the phone.

The surface quasiparticles of plasmas enabled the further insight into the interaction between the light and the surface for welcome industrial influences of semiconductors and metals. The topology of plasmons has become a first-class tool for the interpretations of the unusual phenomena of superconductivity and magnetism of thin films with which researchers have increased the massive uses of thin films in the industry. The scattering characteristic of plasma thin films of the professor of Jožef Stefan, the Ježica by Ljubljana native Karl Robida (1857-1858), have found their theory in the research of their Carinthia countryman Duncan Haldane a century afterwards. So far Robida's and related experiments with thin films guided theoretical search, while Duncan's theories go the opposite way and give advice to appropriate measurements which bring profit, even if in 1988

Duncan did not advise any experimental verification of his ideas until it was achieved with new low temperature aids for the detection of fermions (electrons) developed in the welfare of the thin layer industry a quarter-century later.³³⁹²

After three decades of exploring one-dimensional chains of small magnetic atoms, Duncan was finally able to get into an additional dimension of two-dimensional thin films of his comprehensive Carinthia-based spiritual ancestor, Stefan's professor Karl Robida. In June 2011 Duncan embarked on other areas of research of plasmons in the fractional quantum Hall effect (FQHE), discovered in 1980 by German Klaus von Klitzing (* 1943) in electrons flowing unusually tidy while limited in thin films between two semiconductors near absolute temperature zero. The conductivity of electrons steeply grows up in the proportions of integers with the reinforcement of magnetic fields irrespective of the purity of the measured substance. That phenomenon is obviously a topological feature, just like the number of holes in the object.

With Thouless' FQHE Topology, Duncan went from one-dimensional system to a two-dimensional system of electrons. Duncan spread the original model of plasma of Stanford critic of global warming ecosystems Robert Betts Laughlin (* 1950) to the hierarchy of characteristic states of condensed quasiparticles. So, Duncan as a very especially stubborn son of a Slovenian mother with his second dimension of thin films returned to his once refused unpublished thinking developed during his post-doctoral study in Grenoble in 1981/82. A decade old discovery of superconductivity of the thin films of Haldane's British fellows Michael Costerlitz and David Thouless helped a lot, therefore they shared their Nobel prize. Haldane first completed topology of unidimensional small chains of magnetic atoms resembling the former Ampère's vortexes.

Duncan ascribed to the even chains of such magnetic atoms the topological features of half-

³³⁹² Duncan Haldane. Model for a Quantum Hall Effect without Landau Levels: Condensed-Matter localization of the "Parity Anomaly". *Physical Review Letters*, 61 (18): 2015, 1988; Gregor Jotzu, Michael Messer, Rémi Desbuquois, Martin Lebrat, Thomas Uehlinger, Daniel Greif, Tilman Esslinger. Experimental realisation of the topological Haldane model with Ultracold fermions. *Nature*, 515 (7526): 237-240, 2014.

spins at both ends of the chain, but not to the odd chains. Those spins are in fact common properties of chains that can enable decoding of information in the future quantum computers³³⁹³ at escalating speed and miniaturization, which is undoubtedly still waiting for us.

Duncan's topological insulators do not translate electricity in their internal parts but only through their thin-layer two-dimensional surface in their own kind of skin-effect that with much higher voltages fascinated Nikola Tesla's charismatic public appearances a century earlier.

Duncan's thin films maintain the same topological properties during their deformations, until we break them up. The topological Gordian knots resemble the ancient Alexander's knot or Descartes' vortexes: they are easy to follow, but hard to destroy, because they are protected by their own dynamics of preserved symmetry necessary to maintain the T symmetry (*Time Reversal Symmetry*).

There are no topological differences between most of the balls according to Duncan's speech at the Stockholm Nobel Prize banquet; the games with perforated balls and other similar accessories in the form of a popular bagel would be very interesting, such as, for example, the Sinjska Alka (Alka of Sinj) of Dalmatian Adriatic shore competitions from the 18th century or new American eight times pierced wiffle balls, perforated boomerang, or frisbees.

In the 1970-s the senior researchers still assumed that the two-dimensional ordered symmetrical structures of the thin films could not be persistent due to thermal fluctuations. Without order, the phase transitions between the individual phases cannot appear. Those erroneous doubts repeated the similar distrust in Laue's crystalline diffraction grid for X-rays because of its thermal motion six decades earlier. The hidden thermal fluctuations ultimately proved to be much more ordered than their initial designers Stefan-Boltzmann-Maxwell believed during early era of massive workers' motions in growing cities because those same workers steadily transformed form nameless objects into modern individuals.

³³⁹³ Elisabeth Gibney; Davide Castelvecchi. Physics of 2d Exotic Matter wins Nobel. *Nature* 538, 18 (6 October 2016); <https://arxiv.org/pdf/1612.00076.pdf> retrieved on March 3, 2020.

It turned out that also for thin two-dimensional layers we have a persistent arranged topology. The phase transitions of two-dimensional thin films between states with different topologies (KT transitions of Michael Kosterlitz and David Thouless) show equally similar non-continuity of individual parameters as they are known at other phase transitions between aggregate states, but no symmetry breaking occurs.

The parameters of phase transitions are becoming increasingly unusual by developing of the research of thin films, even if the system of non-continuous transition from one state to another is always the same. Duncan's phase shift involves a non-continuous change of topologies of two-dimensional thin films. The low temperature superconductivity of thin films disappears during the topological phase transition at higher temperatures. The ancient (Descartes') swirls are adhering to solid pairs at low temperatures, but after the KT phase transition at elevated temperatures, however, those vortices abandon their pairs and fly separately. Already Descartes has proposed his simple model of a space full of vortices swirling in mutually opposite directions. Newtonians found all swirls completely unsympathetic, which, for some time banished them from Duncan Haldane's British archipelago, while Euler, Ampère, Cauchy, Gauss, Robida or Stefan's disciple Ljubljana-Maribor professor Luka Lavtar never abandoned those nice vortices.

30.2.4.2 Nobel Laureate in Bled

Between 26th and 30th April 2000 Duncan of Princeton was an invited Lecturer at the Bled Conference *Open Problems and Strongly Correlated Electron Systems*, headed by Peter Prelovšek (* 1949), Ramšak, Igor Sega and Janez Bonta (* 1960). Duncan lectured on the quantum Hall effect. He announced the phase shift of the first order of pairs of electrons and another non-associated phase with lines of compressed anisotropic Smectic Phase. Lines are one-dimensional arrangement of the density of charge in the high temperature superconductors, which were a little earlier discovered and confirmed in 1986, while their most quoted but incomplete theory was proposed by Duncan's supervisor Anderson in the next year.

Duncan proved that the observed lines are not related to superconductivity, because they belong

to a special phase. In addition, among the thirty lecturers was also Vinko Zlatić (* 1974) from the Zagreb Institute Rudjer Bošković.³³⁹⁴

In Bled, Duncan told Peter Prelovšek about his mother's Carinthian Slovenian heritages. Duncan also narrated to Žlatić about her Partisan pursuits that could have deprived her of Austrian citizenship immediately upon her relocation to London. Of course, Duncan's work does not belong to an extremely eloquent or understandable readings but he combines his brilliant physics with extremely deep theoretical considerations.

30.2.4.3 Conclusion

The topology of the Seven bridges of Kaliningrad (Königsberg) and the polyhedral formula were designed by Leonhard Euler in 1736 and 1750. Euler's four years younger contemporary Bošković in the course of his visits in Ljubljana in 1750s and in 1760s researched dimensionless substances which he used to build his three-dimensional substances with some difficulties. In 1832 and 1835 the Ljubljana Professor Leopold Karl Schulz Edler Strassnitzki has supplemented Euler's polyhedral formula by significant evidence, while in the following two years Augustin-Louis Cauchy added his own bettering in Gorizia. In 1847, Gauss' student and Weber's replacement as the Göttingen professor Johann Benedict Listing (1808 Frankfurt-1882 Göttingen) coined the term topology, while in 1870-s the slightly unbalanced Georg Cantor developed his theory of sets needed for the topologies. In 1895 Einstein's competitor Henri Poincaré, advances his topology in his *Analysis Situs*. In those days, of course, Duncan has not yet been even planned by his ancestors and even Nobel has not started delivering his fancy prizes. Anyway, all was ready for Duncan's performance except for the fact that physicists are delayed in their using of the imaginative novelties of mathematicians. In Duncan's case, the delay was a century long.

In the meantime, the scholars had to make sure that the small invisible particles really influenced the big ones: it was not just the particles of physicists and chemists, but even more the ones of living species, since Pasteur initially has convinced no one that a small bacterium can kill a big man or a horse; the people still feel like in Hippocratic's

³³⁹⁴ Haldane, 2001, 203-213; Anderson, !!!5 1987. 1196-1198.

times. They preferred to see the environment as the cause factor of diseases of humans', dogs' and potatoes' (1845-1846) which Pasteur didn't particularly love. Barely a quarter of century of Pasteur's experiments with selective manual separating of one type of substance from other convinced our ancestors in microbes which the officious Pasteur found everywhere, even during his lunch.³³⁹⁵

Two-dimensional thin films and one-dimensional chains of small magnetic atoms of similar former Ampère's vortices already attracted the student Duncan Haldane much more than one-dimensional strings of fundamental quantum-mechanical research of uniform field theory. Instead of astrophysics, Duncan started with his solid substances, as he felt that the theory of strings somewhat damaged physics of post-Manhattan bombers because the whole generation of strings' fans in some way remained a torso. Two-dimensionality obviously offers more than one-dimensionality which soon also affected Duncan's Nobel pocket. His staying on solid soil of solid-state physics solids payed much better than buzzing on the strings of the foundations of physics. Undoubtedly, it is Noble to be Nobel's chosen one, but it is also the opportunity for Slovenians to supplement Duncan's Slovenian Nobel Prizes with the other seven eights.

The strangeness of a thin layer in Duncan's predictions was particularly typical of Nobel Prizes in 2016, as it has finally been touched by contemporary music, which has been a cradle of first-class literature for half a century, especially with Bob Dylan and his Stockholm deputy Patti Smith. Finally, the Swedish Academy acknowledged the new media that the Duncan's quantum computers continue to accelerate.

30.2.5 *Merits of Modern Slovenian Experts Connected with DVTS, IEVT, IMT and IJS*

30.2.5.1 Introduction

The Slovenian research of sciences related to vacuum has an eminent tradition. Prince Johann Weikhard Auersperg was nearly the only person

whom Otto Guericke mentioned in his book about the pioneering vacuum experiments. Guericke reported that Auersperg's doubts forced him to modify and approve his tools. Auersperg just became prince and worked as the informal prime minister of the Viennese Emperor. He was born in castle Žužemberk of the present days Slovenia and died in his amazing baroque palace of Ljubljana where he collected many vacuum-related curiosities and the best private European library of his era where no vacuum-related item was missing. He collaborated with leading Jesuits vacuum researchers of his times including Gaspar Schott who pioneered the announcement of the Guericke's vacuum equipment. Schott's teacher Athanasius Kircher witnessed the early barometer experiments in Rome, dedicated to Auersperg a part of his book *Oedipus*, and donated many books to the Auersperg's library of Ljubljana. Later Auersperg became too mighty and the new Emperor forced him to live Vienna for Ljubljana where Auersperg began to spread his knowledge through his high society circle which included leading local Jesuit literati and Valvasor. Soon after his death the public higher studies were established in Ljubljana and Gorizia to match the already existing ones in Vienna, Prague, Olomouc, Graz, Trnava, Košice, Klagenfurt, and Zagreb of the same Jesuit Province. The Jesuit professors frequently rotated between those colleges and spread their knowledge initially based on Kircher and Schott's ideas of vacuum. A century after Guericke-Auersperg's Regensburg experiments a physics laboratory was established in Ljubljana Jesuit College under the leadership of the grandson of Auersperg's customs officer baron Erberg. In next decades the Ljubljana Jesuits shared their laboratory equipment with similar laboratories along the province to provide the relevant knowledge to their students who build up the modern Slovenian Vacuum Techniques. The 17th century Auerspergs were la crème de la crème and were not guilty for prince Alfred and Agatha Auersperg Nazism in 1930s and 1940's and also were not connected with the fact that prince Auersperg sold his Gottschee property to Italian-Fiume company at the best price to expropriate-resettle Gottscheers who trusted him in vain.

³³⁹⁵ Dubos, Rene J. 1950. *Louis Pasteur Free Lance of Science*. Boston: Little, Brown and Company, 242-243, 248, 259, 265-266.

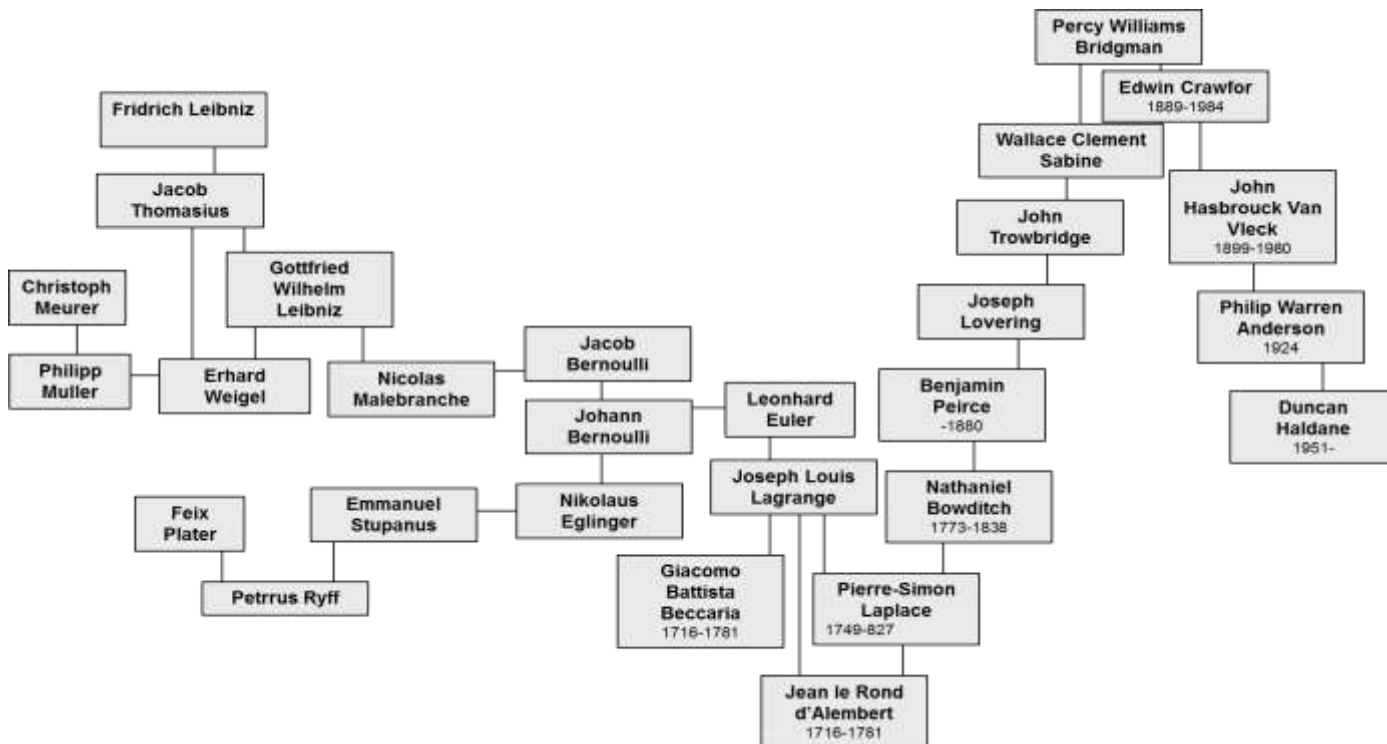

Figure 30-52: Duncan's academic ancestors in the history of electricity research including Bošković's friend Turin professor Piarist Giacomo Battista Beccaria. Duncan's Academic Ancestors down to the famous Leibniz, who founded the magazine Acta Eruditorum where Valvasor published about his Ljubljana thin walled sculptures

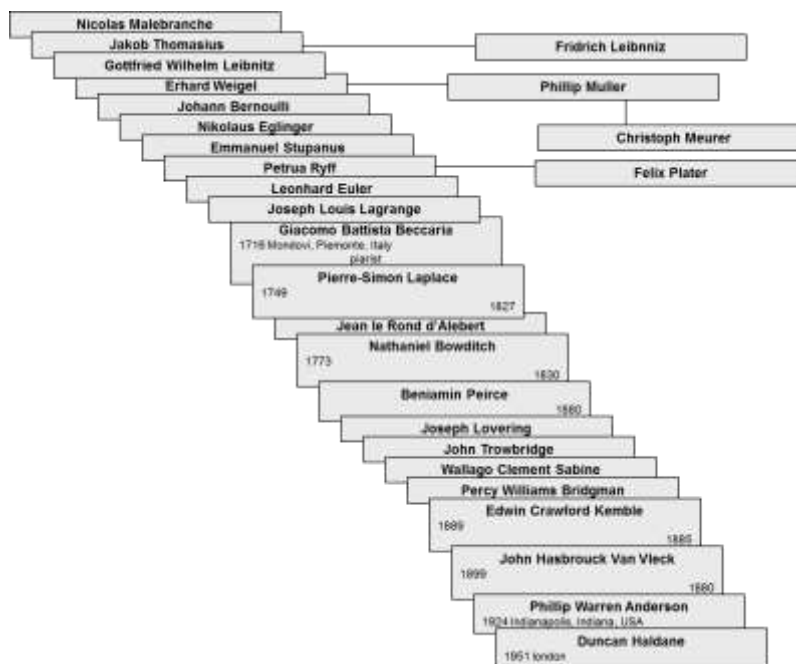

Figure 30-53: Duncan's academic ancestors selected according to their doctoral supervising. The first professors of physics at today's elite American Harvard University were self-taught. Therefore, we had to attribute Laplace as an academic ancestor to Bowditch and the friend of his son Benjamin Peirce because of their translation of Laplace's works. Among Laplace's academic ancestors was also Lagrange because of Laplace's original publications in the Lagrange's Torino Gazette. Bowditch was grateful for his education to the local pirates. In the 1770s they robbed a ship on its way from Ireland to England during the Revolution and found onboard the library of Irish separatist phlogiston gas researcher Richard Kirwan (1733-1812). A century later, Americans no longer had to plunder European books, but rather brain drained their writers by the promise of their thicker wallet among Americans.

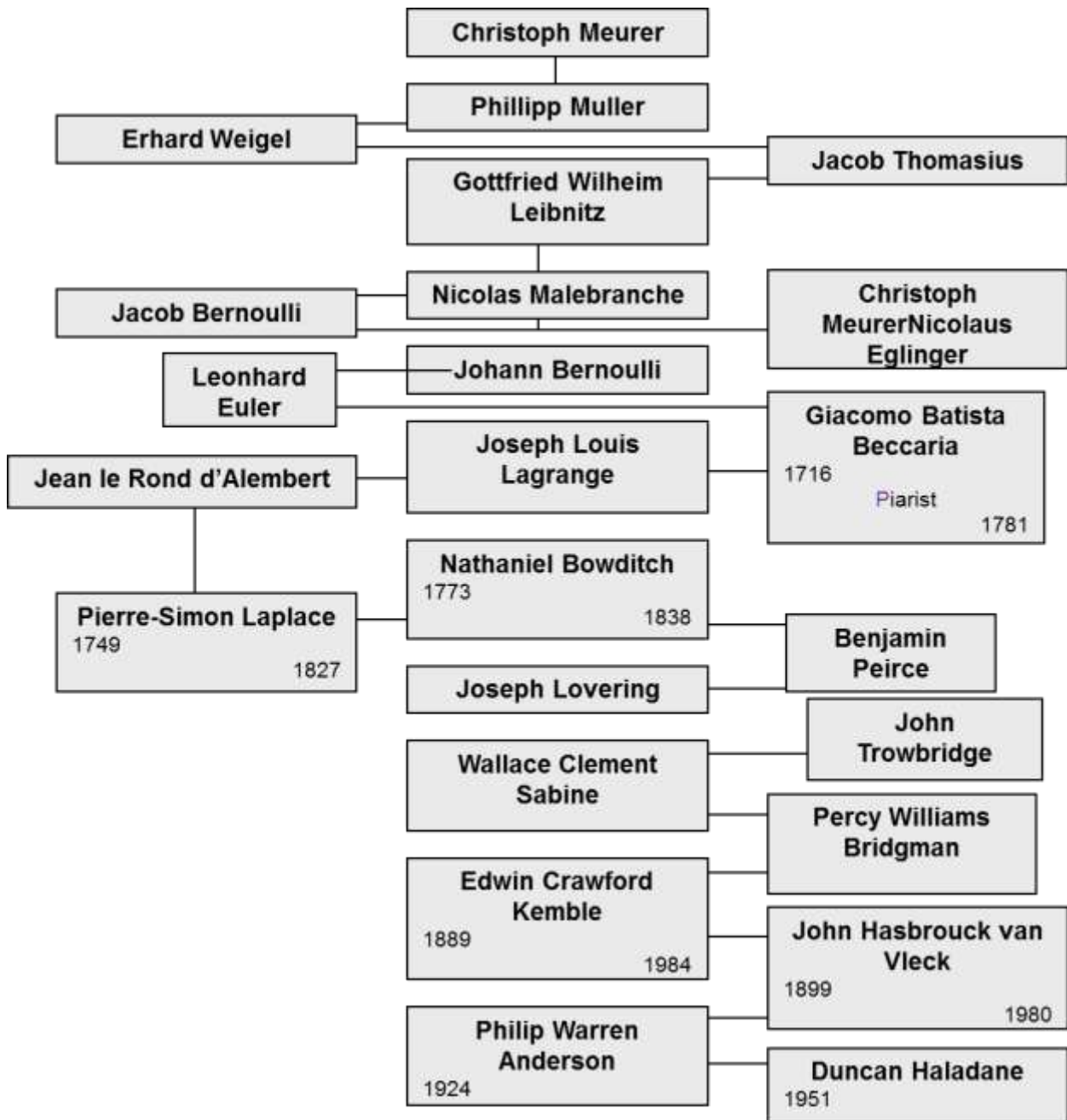

Figure 30-54: Duncan's academic ancestors from another point of view.

30.2.5.2 Institute for Electronics and Vacuum Technique (IEVT)

Auersperg's descendants in Ljubljana vacuum research especially flourished with Dušan Lasič and Evgen Kansky (1926-1987). Dušan Lasič (1908 Gorica-1980 Vrsar) graduated in 1933 in Electrotechnical section of Ljubljana Technical faculty in 1933. He joined partisans and headed the broadcasting radio in Stare Žage of Lower Carniola and worked for Ljubljana radio Kričič during WW2. In 1949 he established the institute

for electronic of Ljubljana EF which under his leadership (1949-1966) developed into Vacuum laboratory on Aškerčeva 9 in Ljubljana in 1950 to give birth to IEVT named in 1970s. As a leading researcher of cathode ray tubes, he was the first president of Yugoslavian center-committee for vacuum technique (JCVT) from 23rd October 1960 to 1962 when he was replaced by Kansky. Among his collaborators in IEVT was his wife Vida Jelka (1920 Zagorje ob Savi-1997 Ljubljana) who also worked for radio Kričič of Ljubljana during WW2. She graduated from the Faculty of Electrical

Engineering, and after graduation led the experimental production of electronic elements in the field of vacuum technologies at the Institute of Electronics and Vacuum Engineering in Ljubljana. Dušan Lasič was a great Alpinist and passed his passion to his IEVT collaborators including Jože Gasperič. Dušan Lasič's son the pioneer in the development of liposomes in medicine Danilo D. Lasič (Dan, Laki, 1952-2000) world-renowned authority on liposomes, passed away at his Newark Californian home on October 14, 2000 at the age of 48 as a leader of his own firm Liposome Consultations in Newark. He did not witness the new biotech millennia he helped to build as heart attack carried him away in front of his home TV while dreaming about his new farm in Nebraska. Dan did not bother much for his insurances which forced his Californian collaborators the Greek Stelios Tzannis of Inhale Therapeutic Systems Inc. (today Nectar Therapeutic in San Francisco) from San Carlos (now resident of Newark) and Jeffery G Weers from Inhale Therapeutic Systems Inc. in San Carlos (now resident of New Mexico) to collect funds for education of his daughter the translator and even IJS discussed the possibility to cover the cost of his last medical treatments. Dan was born in Ljubljana on August 7, 1952. He graduated from the University of Ljubljana in 1975 with a degree in Physical Chemistry. He received his M.S. in 1977 at the same University and his Ph.D. degree with his research of the lyotropic liquid crystals in 1979 at Blinc's Solid State Physics department at the J. Stefan Institute in Ljubljana. There he collaborated with a writer of this lines always encouragingly asking about the time I had to wait to get the results of my experiments and cheering when I told him about the short time needed. He then undertook postdoctoral studies with Dr Charles Tanford at Duke University, and Dr Helmut Hauser at ETH Zurich from 1982 to 1984. In 1984, he returned as a research fellow at the B. Kidrič chemistry institute and J. Stefan Institute, where he remained until 1986. In 1986, he became visiting professor at the Department of Physics at the University of Waterloo in Canada, and in spring 1988, he continued his research at Clarkson University in New York. In September 1988, Dan left east coast for west coast to join the Liposome Technology Inc. (LTI), now the Alza Corporation in Menlo Park, CA, as a senior scientist and widely collaborated with Rudi Podgornik. While he searched for new feasibility of molecule

modulations, he led studies designed to provide a theoretical understanding of long circulating (stealth) liposomes discovered in 1961 as entities having at least one lipid bilayer. His academic research on the thermodynamics and mechanism of vesicle formation was an excellent preparation for his active participation in the development of 'stealth' liposomes at LTI(Lymphoid tissue-inducer cell). He also developed the first formulations for preclinical studies and actively contributed to the scale-up of a 'stealth' liposome laden with the anticancer agent doxorubicin. This formulation later became the first US Food and Drug Administration (FDA)-approved liposome formulation in 1995. He began research on interaction of cationic liposomes with DNA, and the use of these complexes in gene delivery and gene therapy. In March 1994, Dan joined Megabios Corporation Burlingame, CA (later Valentis, Inc. at Burlingame), where he continued his research on cationic liposomes, DNA lipid complexation and associated scaleup issues. Shortly after leaving Megabios, as the US citizen he formed his own consulting company, Liposome Consultations Newark, CA. in October 1996. Over his last four years, he worked in various ways with the Drug Product Research department at Roche Bioscience Palo Alto, CA. Dan published more than 160 refereed papers in prestigious journals, including Science, Nature and Proceedings of the National Academy of Sciences (PNAS), while giving numerous invited lectures. Furthermore, he authored or edited seven books on liposomes and drug delivery, including: Liposomes: From Physics to Applications Elsevier, 1993, Liposomes in Gene Delivery CRC Press, 1997, Stealth Liposomes CRC Press, 1995, and a four-book series, Nonmedical Application of Liposomes CRC Press, 1996. His best-known papers are those that deal with thermodynamics and the mechanism of vesicle formation, the origin of biological environments stability of spherical vesicle liposome, their gene delivery related to viruses, and the applications of drug-laden liposomes. He postulated the first model of liposome vesicle formation widely known as the 'Lasic model'. Dan has been the co-inventor on several patents on the application of liposomes for the delivery of doxorubicin and other anticancer drugs. He received numerous citations and mentions in the 'Who's Who in the World', 'Who's Who in the West', 'Who's Who in Science and Engineering' and 'Men of Achievement'. He served on the

Editorial Board of several journals including the Journal of Liposome Research and Current Opinion in Colloid and Interface Science, where he was also a section editor.

Dan's success was enabled by his awesome Ljubljana predecessors. Evgen Kansky junior was a son of medicinal-chemist of Jewish genus Evgen Kansky (1887 Warsaw–1977) and a chemistry expert mother Ana Mayer Kansky (Anka, 1895 castle Lože by Vipava–1962). After she completed the first (female) PhD in Ljubljana in the chemistry class of Maks Samec and his assistant Marius Rebek (Marij, 1889 Barkovlje (Barcola) suburb of Trieste-1982) in June-July 1920, Ana Mayer married Evgen Kansky next year. She taught at Secondary Technical School in Ljubljana after WW2 where the teachers from IEVT lectured about the vacuum techniques to the students of final 4th class of electrotechnical department in 1961 and 1962. By the recommendation of the Bohemian president Tomáš Masaryk her husband Evgen Kansky senior moved to Ljubljana, where he taught chemistry and physiology at the newly founded medical school. He and his wife founded a chemical company in Podgrad by Zalog by Ljubljana in 1922 to produce ether and its compounds which made Ana the very first Slovenian female user of sophisticated vacuum techniques. Her husband was president of the International Society of High Vacuum Chemistry.

In summer 1950 Dušan Lasič (1908 Gorica-1980 Vrsar) invited Evgen Kansky junior and France Lah to the Institute of the weak currents of the Ljubljana Electrotechnical faculty which later developed into institute for Electronic and automatization and then to its heir IEVT. Evgen Kansky junior graduated in 1951 and received his PhD in 1961 at FNT of Ljubljana. Evgen Kansky junior was a professor of chemistry and thin-films analysis in vacuums at the University of Ljubljana's Faculty of Natural Science and Technology. In 1990 Peter Panjan edited for DVTS Kansky's textbook *Nastajanje in rast vakuumskih tankih plasti* (Vacuum thin film formation and growth) as Kansky's great posthumous heritage.³³⁹⁶

The research of vacuum related tools in Slovenia was further advanced by Paulin, Andrej Pregelj,

³³⁹⁶http://www.dvts.si/arhiv/1984/1984_2/1984_2_1_100dpi.pdf retrieved on March 3, 2020

Gasperič, Zalar, Šetina, Mozetič, Nemanič, Kovač, Monika and Bojan Jenko. The professor Alojz Paulin (Paulin, * 1930 Podbrezje in Franckova house) is the oldest Slovenian Vacuum researcher today. He has mainly developed accelerators, and today as the pensioner lives in his native areas of Tržič. Among his PhD students was also Janez Kovač whose ancestors were at home from Srobotnik in Kostel where his mother organized the building of the local bell tower in 1990s. After graduating at Kočevje Grammar school Janez Kovač graduated in physics of nuclear quadrupole resonance in J. Seliger's class (1990) and studied electrical characteristics of Schottky's structures for his PhD in Paulin's class in 2000. Kovač was trained in Bazovica (Basovizza) Elettra-Sincrotrone near Trieste in Italy and later joined IEVT which subsequently became the part of IJS. Until 2020 Kovač was a president of DVTS and then the general editor of journal *Vakuumist*.

In 1979 Andrej Pregelj graduated with the work Technological utility of blacksmith rolling at the Faculty of Mechanical Engineering in the class of Karl Kuzman (* 1941 Vitanje northeast of Celje halfway to Žreče). In 1994 Andrej Pregelj crowned his education with master's degree focused on Compact microwave tube: design proposal for measuring HF properties of superconducting materials in Paulin's Maribor class as an able experimentalist lastly working for the lighting protection in Iskra. His wife is the granddaughter of the chief J. Plečnik's liberal competitor architect Ivan Vurnik and the leading Slovenian physicist Slobodan Žumer (Daša, * 1945) is Andrej's brother-in-law. Andrej Pregelj became the heading figure in Ljubljana gymnastic society Sokol as its president in 2007-2015 where he regretted that his organization never got back its nationalized real estates in Bežigrad unlike it's happier Sokol branches in Zagreb and Bohemia who received back their property lost after WW2. After the suppression of his IEVT firm Pregelj got his new job in Iskra lightning rods production. Soon afterwards he retired to his house in Mirje by Roman Walls in downtown Ljubljana where he disliked frequent sitting behind the computer but loved to write and research about the local history of vacuum techniques and the Slovenian Sokol. Pregelj is among rare nice persons who managed his friendly relation with Paulin and Gasperič in the same time as Paulin stated that Pregelj's

masters' thesis is more valuable than most of the PhDs.

Prof. Dr. Miran Mozetič received his B. Sc. Degree of Physics from the Faculty of Natural Sciences and Technology, University of Ljubljana, Slovenia in 1988. In 1992 he received the M. Sc. Degree from the Technical Faculty, University of Maribor, Slovenia, and in 1997 the Ph. D. Degree in electronic vacuum technology with his research of hydrogen plasma interaction with solids surfaces at Paulin's class of the Faculty of Electro-technique, Computer Sciences and Informatics, University of Maribor. In 1993 he attended courses on Application of synchrotron radiation techniques at International centre for theoretical physics in Trieste, Italy. He joined Jožef Stefan Institute in 2003 and since 2009 he is the Head of Department F4 (Department of Surface Engineering) developed from the former DVTS as the leader of a research group of surface engineering. His research interests include interaction of nonequilibrium plasma with organic and composite materials, fusion oriented research on plasma surface interaction from his PhD, plasma nanoscience and plasma techniques for biomedical application. His R&D activities are related to plasma science and development of plasma systems for industrial applications. His bibliography includes about 30 patents granted by different offices and 300 scientific papers with H-index of 37. He was a president of DVTS before Janez Kovač took over.

Vinko Nemanič of Bela Krajina origins graduated from the class of M. Kregar in 1981 and started his research optoelectronic for special cathode ray tubes in IEVT in the group of E. Kinsky. He received his master's degree in the class of A. Paulin in Maribor in 1991. He received his PhD with a research of vacuum thermic insulation at the class of Alois Poredoš and Peter Novak in 1997.

30.2.5.3 Jozef Stefan Institute (IJS)

Kinsky's colleagues excelled by their research of the thin films including Boris Navinšek, Peter Panjan, J. Dolinšek and Miha Čekada. The basic research of thin films is engaged in the section for thin films and surfaces of the Jožef Stefan Institute (IJS), notably in cooperation with the Balzers company. In the first half of 1960s professor Dr. Boris Navinšek produced the first simple "desktop" device for ion bombarding and Ion etching while

his results of the 1965 were reported in the American Magazine and in 1964 in the editions of IJS. He received his PhD in the year 1968 and further graduated in the class of director Osredkar with the research of the surface effects and radiation etching caused with low energy ion bombarding in solid and thin-film targets. As a kind of prophet, he promoted his early idea of the advantages of streamed sputtered protective layers, which he presented with his collaborator Viktor Kraševac at consultation on the new methods of surface protection of NATO's Advanced Study Institute on Science and Technology of Surface Coating at Imperial College of University of London in April 1972 with their anthology published in edition of Brian N. Chapman and the keen Jazz pianist Imperial College chair Joseph Chapman Anderson (Andy, 1922–2001) two years later. Navinšek's group assembled its own ion bombarding device and while their sputtering tool Sputron was purchased at Balzers in 1978. In their home workshops they produced a cylindrical sputtering device with titanium cathodes for the application of hard-coated tools.

At the end of 1970-s after large investments and many researches the Balzers has penetrated to the promising market with hard protective coatings. In 1983 the Balzers began to develop its special research and production centres on all continents to provide Balzers's leading place in the world. The Balzers supported the participation of the Ljubljana Group, which protected domestic thin-layer technology with the patent and the brand JOSTiN in the twenty-three countries of Europe in 1983. On 18. 12. 1985 they opened the centre for hard coatings in Domžale. There for industrial needs they covered tools by protective coatings with an evaporation apparatus Balzers BAI730 including all the required tools for the TiN coatings whose purchase financially supported the Slovenian firm SMELT.

After the discovery of high temperature superconductivity in 1986, research of thin films from modified $\text{YBa}_2\text{Cu}_3\text{O}_{7-x}$ (YBCO) based on Sapphire (Al_2O_3) and MgO also started at the IJS. The products are used for precise magnetic field meters. The basis of MgO is particularly useful because there we can achieve a critical temperature above the boiling point of N_2 at the temperature 77 K.

The quasi-crystalline coatings soon became one of their best tools. The professor Navinšek retired in 2002 while for next leaders of the department of his thin films at the Jožef Stefan Institute, he successfully employed Peter Panjan and Miha Čekada. Peter graduated in 1980 at F. Cvelbar's class and received his PhD at the Ljubljana Faculty of Metallurgy in the field of materials, the same as later did Dr. Čekada, who took over the leadership of their department in 2012. In 2004 together with J. Dolinšek he took over the advantages of high hardness quasi-crystalline covers and began to produce the extremely solid covers among the first in the world. Under the then liberal government with Gregor Golobič (* 1964 Novo Mesto) as Minister for Science and Higher Education of Slovenia between November 2008 and June 2011 with the motto: "Znanje Žanje" meaning that the "knowhow gets the harvest" P. Panjan's department purchased many new tools in their new headquarters in the basement of IJS.

30.2.5.4 Institute of Metals and Technology (IMT)

Most of Ljubljana vacuum research and educational facilities were always located in Vič area southwest of Roman Town Walls of Mirje including IJS, EF, IEVT, and IMT. Janez Šetina heads the Pressure Metrology Laboratory Institute of Metals and Technology (IMT, Institute of Metals and Technology) with expertise in Instrumentation Engineering. His senior Monika Jenko of the Department of Physics and Chemistry of Materials of IMT completed her PhD in Material Science at the University of Ljubljana. For eleven years she was the director and initiator at the Institute of Metals and Technologies (IMT) and later joined the Jožef Stefan International Postgraduate School with Advanced Metallic Materials in the framework of the Nanoscience and Nanotechnology study program with an expertise in the field of Material Science, Applied Surface Science, Surface Engineering, Nanoscience and Biocompatible Materials

30.2.6 *The First Slovenian Female Vacuum Researchers*

30.2.6.1 Introduction

Monika Jenko certainly belongs to the best users of vacuum technology, while she has valuable predecessors and descendants. The brave empress

Barbara of Celje opened our story of new materials and vacuum technologies. Many important men followed her pioneering calls through the centuries. Almost half of millennia passed with the research at least officially almost entirely belonging to wealthy white man's business. Suddenly it happened and their monopoly ways were broken with academically trained woman, non-whites and sometimes even the children of poor families. The Slovenes have always been deeply aware of the achievements of women scientists. We have explored that development from the first books of female physicists available in areas inhabited with Slovenians up to first Slovenians female vacuum researchers, who studied before 1963.

30.2.6.2 Writers about Vacuum Techniques and First Female Students of Physics

Already in 1678, the new Ljubljana bookstore of Janez Kersnik Mayr offered to the erudite of Ljubljana mathematical and astronomical works of Maria Kunic married von Love (Kunitz, Cunitz, † 1664). Among 2566 Mayor's titles, her book was the only one written by a woman's hand. Not far from the Slovene national territory, the first lady of mathematics Maria Gaetana Agnesi (* 1718; † 1799) took over the chair of mathematics and science at the University of Bologna in 1750. Five years later, the Trieste professor of mathematics, Franjo Orlando, had already acquired her book on analysis for his instructions of the future sea captains and skippers. F. Orlando taught many Slovenians; so, Slovenian ancestors have long known that mathematical and physical sciences are not entirely male occupations.

Among the first books on solid state and crystals was the work of Elizabeth Fulham, the wife of dr. Thomas Fulham. In her high English society, she discussed with the most important scientists of her age, especially with Joseph Priestley. Her thinking about phlogiston was very interesting for Lavoisier in Paris. Unfortunately, Lavoisier lost his head a few months before the publication of Elizabeth's book, which contained even the beginnings of the subsequent discovery of catalysis.

Slovenian vacuumists began to establish themselves a century ago, when women began to enroll at the universities of the late 19th century. They were another new type of students, which

until then had no almost no official academic duties among Europeans. Just before the First World War, the image of the lecture rooms suddenly changed dramatically.

Among the first female vacuum researchers, the Jewess Phoebe Sarah Marx (Marks, 1854 Portsea-1923 Bexhill-on-Sea) has excelled in England. After her marriage she was known as Hertha Ayrton. Hertha's father was a Polish Jewish immigrant who led a small jewelry store in England. She studied mathematics at Cambridge, but in her time, it was impossible for a female to graduate from a university; she received only a certificate in 1880. She therefore had to pass additional exams and graduated from the London University. Soon after graduation, she changed her name from Phoebe to Hertha. In the autumn 1884 she attended lectures at the laboratory of Kelvin's student the professor William Edward Ayrton (1847 London-1908 London), whom she married next year. In 1895, she started publishing on hissing and resistance of electric arc experiments in the *Electrician* magazine, which she summarized in the book in 1902. In 1899 she became the first member of the prestigious Institution of Electrical Engineers. *There, she was the first woman to lecture on the electric arc lightings.* She later addressed to the Royal Society in London. The event aroused many echoes even in the press outside of professional circles.

After her husband's death, Hertha set up a laboratory in her home, and the Royal Society of London awarded her with Hughes' golden medal for her exploring of the arc discharges. From 1905 to 1910, she developed the standardized carbon electrodes for the Navy. During the First World War, she invented a defense against German poisonous gases, but the army refused to accept it.

In the Habsburg monarchy, the girls occasionally received permits for listening to university lectures, but there was no chance for the regular enrollment. For regular studies, a graduation course had to be carried out, and the girls' official academic door was still completely closed in the 19th century. The first girl could regularly enroll at the Faculty of Philosophy at the University of Vienna in 1897, at the Viennese Medical School in 1900, at the University of Heidelberg in April 1900, at the University of Graz in 1897/98 and 1901 and at the University of Innsbruck in 1904.

However, especially in Habsburg Monarchy, the number of female students remained small, while only in imperial Vienna it reached 5%. Wassmuth's physics assistant focused on point contact diodes Angelika Szekely de Doba (Maria Josefa Székely, * 1891 Olomouc; † 1979 Graz) was the first female to habilitate at the Graz University in Natural Sciences and the second among all girls promoted at University of Graz just before Christmas in 1917.

30.2.6.3 The First Slovenian Physicist Maria Wirgler

Maria Wirgler (* 1879; † 1874) was the first academically educated Slovenian woman in physics and in science in general. In 1905/06, after she graduated in Graz, she taught mathematics, physics and natural science at the first Slovene City School of Girls' School in Ljubljana and taught until the school became Lyceum in 1909/10.

The first Slovenian woman with a doctorate in natural science or mathematics was Carinthia native Ángela Piskernik (* 1886; † 1967). On 28. 10. 1914 she graduated in Vienna. She taught physics in Novo mesto and Ljubljana. Although Knafelj's scholarship on 6 November 1678 was established without an explicit restriction on male sex, no girl was given Knafelj's scholarship before the First World War. The first Knafelj's scholarships at the University of Vienna were awarded to Amalija Šimec (1893 Tržič-1960 Ljubljana) in 1915/16 at the Faculty of Medicine, to the countess Victoria de Mestri at the Faculty of Arts, and in 1918 to Hedwig Ebner at the Faculty of Arts (Philosophy).

After Maria Wirgler retired, Dr. Marta Blinc and dr. Dora Kokalj, taught chemistry and mathematics at the Women's Real Gymnasium as guardians of the chemical cabinet. Like Wirgler, Marta graduated in chemistry, mathematics and physics, and she also occasionally taught physics. She was the aunt of Robert Blinc. Marta has published a series of scientific works in the field of chemistry and microbiology. She was the first president of the Union of Microbiologists of Yugoslavia, and she received the Prešeren Prize and many other awards.



Figure 30-55: Matija Čop's catalog note about Madam Fulham's book at Ljubljana Lyceum (NUK, manuscript department; E. Fulham, *An Essay on Combustion with a View to a New Art of Dying and Painting, wherein the Phlogistic and Antiphlogistic Hypotheses are proved Erroneous*, J.Cooper, London, 1794. Translation: *Versuche über die Wiederherstellung der Metalle durch Wasserstoffgas, Phosphor, Schwefel, Schwefellber, geschewfeltes Wasserstoffgas, geposphortes Wasserstoffgas, Kohle, Licht und Säuren*, Gottingen: Dieterich, 1798)

30.2.6.4 Barometers of Serafina Dežman in Ljubljana

Serafina contributed greatly to the development of Slovenian physics and meteorology among the first Ljubljana women. After the death of her brother Karl Dežman († 11. 3. 1889), she continued to measure the weather conditions in Ljubljana and thus complemented the first long-term continuous collection of measurements in Slovenian capital. She measured from 11. 3. 1889 until June 1895, almost until her death in 1896, therefore, she did it alone during six long years and with the help of Kajs in while her brother was absent as Viennese MP in 1861–1863. Like her brother she never married while she literally devoted most of her work to measurements of weather conditions.

Dežman was interested in meteorology even before he took over the observatory. In 1856 in the museum's Reports, he published Zeilinger's measurements accomplished at Prečna ulica of Ljubljana in 1855. In February 1857 Serafina and Karl Dežman took over meteorological measurements of the second-order observatory in

Prečna ulica (former Ljubljana downtown no. 212) from the Ljubljana telegraph officer, Josef Zeilinger (Zeilinger, * 1815) married to Theresa (* 1824) who have birth to his two sons. Overall, Dežman family measured for four decades. During the frequent absences of her brother, Serafina repeatedly replaced him and was very well advanced in using thermometers, vacuum barometers, precipitation gauges and other experimental equipment. She was one of the first Ljubljana experimental physicists and meteorologists, a specialist in vacuum barometers. Dežman used mainly three measuring devices for daily measurements at 6, 14 and 22 'clock. He inherited them from J. Zeilinger who used them already in 1855.³³⁹⁷

- barometer in the Heinrich Kappeller's container, acquired from ETH in Zurich, calibrated at the Viennese Central Institute of Meteorology and Geo-magnetism. In 1856 and 1857, the director Gintl performed control measurements at the Ljubljana Railway Station at the height of 950 feet.

³³⁹⁷ K. Dežman, *Meteorologische Beobachtung zu Laibach im Jahre 1865. Jahresheft Krain. Museum (Ljubljana) (1856) 11.*

- August's psychrometer which was mounted once on the north side of the Zeilinger's observatory. In 1825 and 1828 the high school professor Ernst Ferdinand August (* 1795; † 1870) designed the device based on a proposal suggested by Leslie. August became director of a real gymnasium in Cologne in 1827.

- ombrometer as an instrument for measuring rainfall with a measuring tube of Kappeller. The vessel for catching atmospheric sediments was installed on the roof of the Ljubljana school.

Dežman computed the vapor pressure according to the August's tables adapted to 0° Réaumur. Until 1854, only temperature and pressure were measured in Ljubljana, while humidity was not yet measured.³³⁹⁸ On 21 October 1881, Dežman received a thermometer from Vienna, a precipitation gauge, which was crossed out at his delivery note, and a snow gauge.

Serafina carefully kept all publications on meteorology at her home. In addition to her and her brother's own announcements in the *Laibacher Zeitung*, she also saved the Carniolan newspaper report on the unusual red snow of 1846, on the earthquake in Carniola in 1873 and the world exhibition in Vienna in 1873,³³⁹⁹ where they founded the International Meteorological Organization IMO with twenty countries under the first President Christoph Heinrich Diederick Buys-Ballot (* 1817; † 1890) from Utrecht. Their meeting gave an initiative to explore a relative humidity meter that would be more accurate than the psychrometer.³⁴⁰⁰ Dežman reported particularly on the bloody red snow for the Viennese Academy. The son of Ribnica manor owner Karel Dragotin Rudež (* 1833 Ribnica; † 21 January 1885 Gracarjev Turn) sent those "Snowflakes" to Dežman's Provincial Museum of Ljubljana. There, Dežman examined them under the microscope and discovered their opalescence. In the sediment, the colorful particles were between 2 µm and 20 µm long.



Figure 30-56: The very first Ljubljana user of vacuum experimental tools Serafina Dežman (Seraphine, 29. 9. 1822 Idrija-1896 Ljubljana Prečna ulica no. 6) painted by her niece Julija Pauer's (* Ljubljana) husband Ladislav von Benesch (1845 Slavkov-1922 Vienna) in 1880 (National Museum, Ljubljana). Really a nice lady in her late fifties! Julija's brother Karl Pauer (* 1847 Ljubljana), his wife Ana (* 1850 Šentjernej) and their three children lived with Seraphina at Prečna ulica 6 at 295 m height above sea level across the Ljubljana river from Lyceum (now central market) in 1890. In 1869, Serafina lived with her year and a half older brother at the suburb of St. Peter no. 108 in Ljubljana. Karl and Serafina also lived for a while at Figovec farm with some pigs to maintain in downtown Ljubljana where Serafina stayed below her brother at the ground floor

Between 12 June 1850 and 30 June 1851 Zeilinger in Ljubljana wrote the numbers obtained in his meteorological measurements into the tables which he personally constructed. Serafina and Karel Dežman already entered the numbers obtained in their meteorological measurements in Ljubljana in the official forms of the double A3 format, which were dispatched from Vienna among the observers at the Habsburgian monarchy.³⁴⁰¹ Until 1888, the completed forms were signed by Karl as "Deschmann" and in the following years his sister signed as "S. Deschmann", maybe also to hide her gender as L. Meitner used to do much later. At the

³³⁹⁸ H. Mitteis, Über Meteorologische Linien. *Reports of Grammar school (Izvestja Gimnazije)* Ljubljana (1854) 7.

³³⁹⁹ Archive of Republic Slovenia (AS), Private Archive of Karel Dežman, fasc. 854, box 20.

³⁴⁰⁰ Simon Šubic, Manometer – Hygrometer. *Wien.Ber. II* 73 (1876) 531.

³⁴⁰¹ AS, Private Archive Karel Dežman, fasc. 854, box 15.

head of the tables, the measuring devices were mentioned, especially the Kappeller's barometer. They measured at the seventh and ninth hour of the morning. In the spreadsheet, they recorded the measured pressures and temperatures, while the number of windy days, precipitation and lightning were added separately in the form provided for them on the right side of the bottom of spreadsheet.

Their results were immediately published in short records of the *Laibacher Zeitung*. On 28 January 1857, they published the entire A3 page of their measurements. The upper part of the long half-length side was filled with measurements of moisture, temperature in the degrees Réaumur, and rainfall rates for individual months in 1856. In the lower part of their page printed in newspaper, they published one paragraph about the characteristics of the weather for each month of the previous year. They announced similar but shorter reports at the beginning of the new year. At the same time, their equal measurements were published in the *Bulletin of the Museum Society* with additional details for the years 1856 and 1857.³⁴⁰² The people of Ljubljana were therefore well aware of the weather around them which used to be the topic of their debates as ridiculed by the local poet Franc Prešeren and also very popular in modern global warming era.

On 13 December 1860, Dežman published data on the pressure, temperature and other characteristics of the weather on the day of publication and added the forecast for the next day, like we read in modern newspapers today. He repeated his forecasts on 11. 1. 1869 and later.³⁴⁰³

Serafina has already used European weather maps with isobars for the period from 1 January 1888 to 31 December 1888. As internationally aware expert, she also used the map designed for USA with isotherms painted in colors on 16 October 1872. In the year of her death (1896) she used a whole map of snowfall measured throughout the world. She also collected measurements of other meteorologists.³⁴⁰⁴ Thus, Serafina's legacy is a true history of the Carniolan and even world meteorology of the second half of the 19th century.

A female one. Her brother Karl Dežman published the paper *Das Klima and Krain* without the authorship mark in the book of the doctor Friedrich Keesbacher (1831-1901), printed in Ljubljana in 1883. Dežman was then 62 years old. Thus, we have that discussion rightly for the crown of his and Serafina's 26-year-long management of the Meteorological Observatory of 2nd order in Ljubljana. Dežman used only his and Serafina's measurements from 1872-1881. The limitation on this ten-year cycle is somewhat surprising, since both Zeilinger and later Dežman have already measured all tabulated quantities since at least 1857, except the number of days of lightning and thunder in individual months and humidity in percentage. They also used the same observatory station at Prečna ulica (Crossing street) in Ljubljana. In his early measurements Dežman did not note the precipitation fallen during in the wettest rainy day of the month as the maximum of humidity. For cloudiness, however, he did not calculate the average value, but only counted the number of cloudy days per month.

Even more difficult was the fact that the measurements were recorded in the Parisian *Ligne* (Parisian Mass) and in the degrees of Réaumur until the 1860s. Until 1854, only temperature and pressure were measured in Ljubljana, while humidity was not measured. The Act on the Metric Measurement System was adopted in Austria-Hungary on 23. 7. 1871 with the mandatory use after 1. 1. 1875 as Habsburgian monarchy joined the Metre Convention (Convention du Mètre) signed by representatives of seventeen nations in Paris on 20 May 1875. That treaty created the International Bureau of Weights and Measures (BIPM), an intergovernmental organization under the authority of the General Conference on Weights and Measures (CGPM) where Avčin excelled on Tesla's behalf almost a century later.

Dežman also checked dr. K. Jelinek's analysis of changes in average annual temperatures for Ljubljana and Novo Mesto (Rudolfswerth) after five daily cycles. Ettingshausen's Viennese student Karl Jelinek (1822 Brno-1876 Vienna) analysed 14.9 years for Ljubljana and 9.9 years for Novo mesto. However, Dežman did not write down what period he was discussing. Later, Jelinek analysed those measurements that were sent to him by the

³⁴⁰² AS, Private Archive Karel Dežman, fasc. 854, box 19; K. Dežman, *Meteorologische Beobachtung zu Laibach*.

Jahresheft Krain. Museum (Ljubljana) (1858) 1-18.

³⁴⁰³ AS, Private Archive Karel Dežman, fasc. 854, box 16.

³⁴⁰⁴ AS, Private Archive Karel Dežman, fasc. 854, box 18.

Table 30-3: Dežman's recapitulations of his, Serafina's and J. Zeilenger's measurements noted in the years 1857 and 1858 (K. Dežman, Naturwissenschaften in Krain, Jahresheft Krain, 1858, pp. 3-6, 12-15)

Quantity	Frequency of measurements	Unit
Temperature	Monthly average at 6h, 14h and 22h, the highest and lowest temperatures in each month	Réaumur degrees
Pressure	Equal	Parisian line reduced to 0° Réaumur
Vapor pressure	Equal	Equal
Precipitation (fog, rain, snow, storm)	Number of days with precipitation in the month, the amount of precipitation is summed by months	Parisian lines
Clouds	Number of cloudy days in a month	
Wind direction	By months	

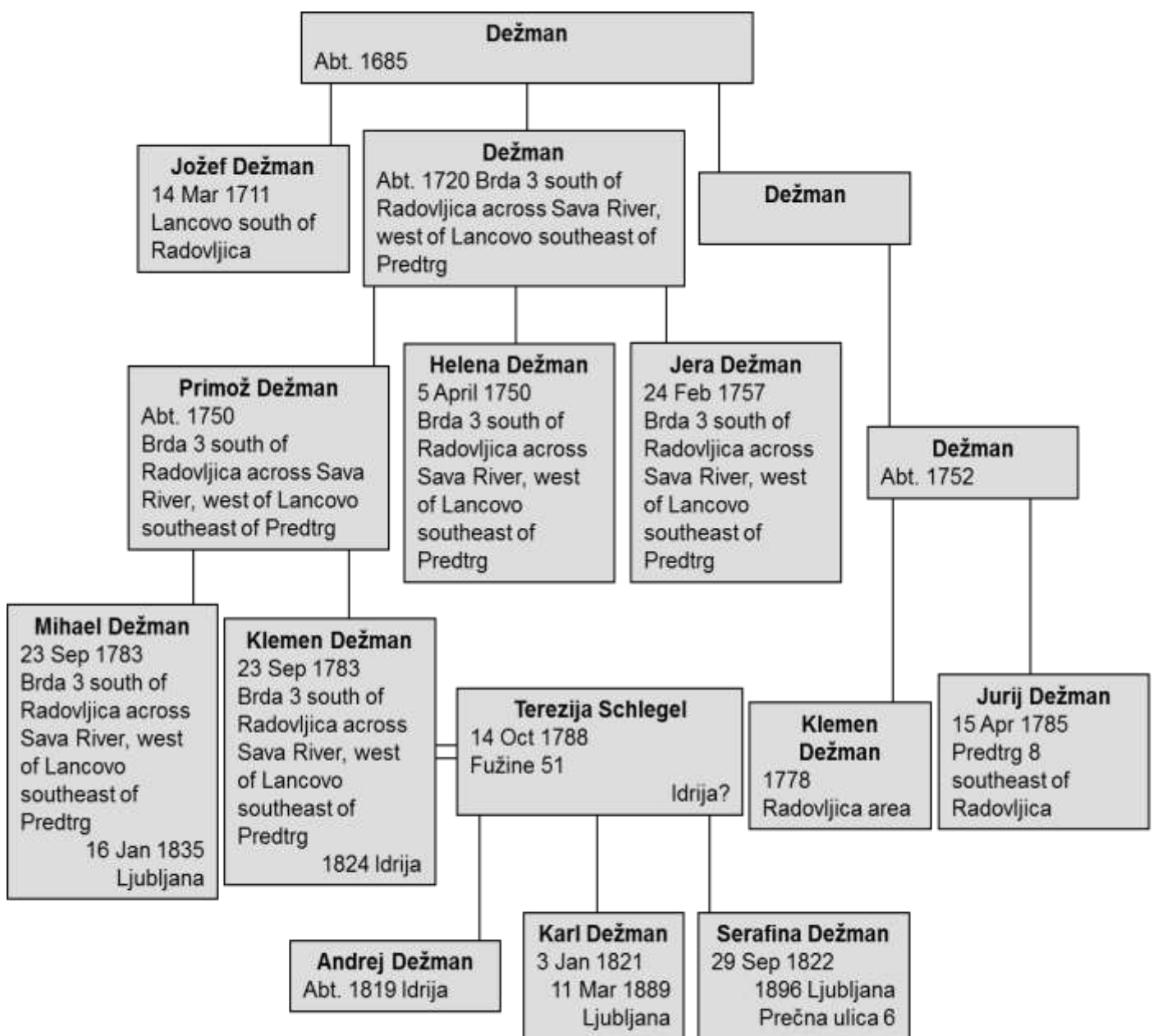

Figure 30-57: Ancestors of Serafina and Karl Dežman

Table 30-4: Dežmans' analyzing of his own meteorological measurement

Quantity	Unit	Average value	Sum	Maximum	Minimum	Number of days	Direction
Temperature	Degrees	+		+	+		
Pressure	mm Hg	+		+	+		
Vapor pressure	mm Hg	+					
Humidity	%	+			+		
Cloudiness	1:10	+					
Precipitation	mm		+	+		+	
Lightnings						+	
Wind	Number of days						+

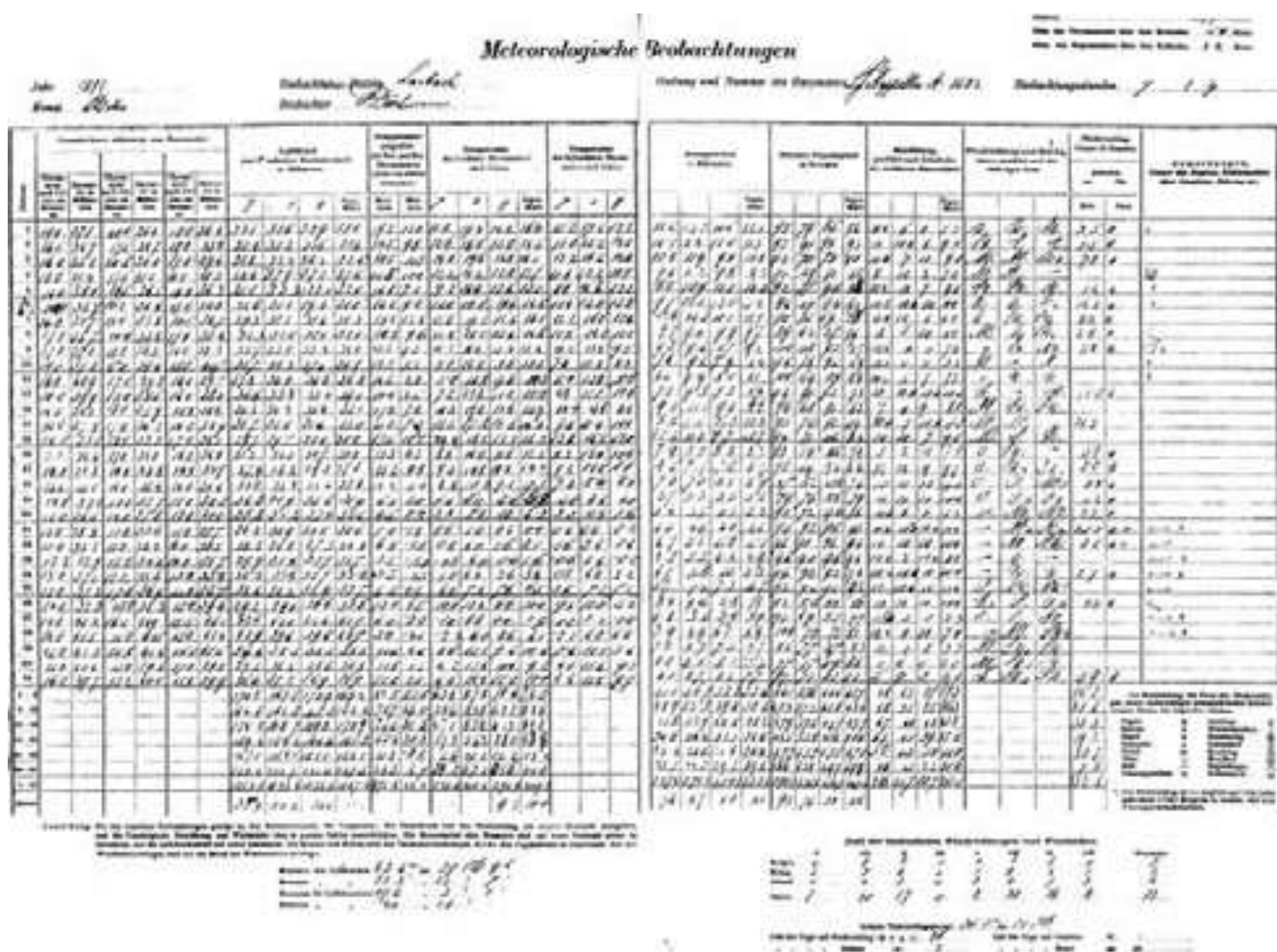

Figure 30-58: Meteorological measurements by Serafinae Dežman in October 1892 (AS, Private Archive Karel Dežman, Fasc. 854, box 17).



Figure 30-59: Serafina Dežman's meteorological measurements in October 1892 (AS, Private Archive Karel Dežman, fasc., 854, box 17). Serafina Dežman is one of the first successful physicists in Ljubljana, specially trained to measure pressures in barometric vacuum tubes. Filip Fröhlich (1826 Metlika-1869 Ljubljana) painted Karl Dežman on a portrait kept by Fröhlich's daughter in Ljubljana.

Ljubljana observers. Dežman and the novice observer, the Franciscan father Bernard Vovk, measured between 1858-1885, and sent their data to Vienna between 1862-1876, where Karl Kreil (1798–1862 Vienna) and after his death K. Jelinek were the directors of the Viennese Central Institute for Meteorology and Geomagnetism (Centralanstalt für Meteorologie und Erdmagnetismus).

Dežman compared the average temperature and precipitation with the measured data in other major cities of the Austrian half of the monarchy. Beyond the analysis of the obtained numbers for Ljubljana, he tried to explain special distinguished local features, inter alia, with the influence of the Ljubljana moor on the change in temperature.³⁴⁰⁵ Most notably, Dežman analysed temperature measurements on 2.5 pages while analysing the other seven measured quantities on a total of four

³⁴⁰⁵ Dežman 1858 3-6; Dežman 1883 12-15, 19-21, 23; Mitteis, 1854, 7; Miroslav Kurelac, 1981, 86.

pages of his discussion. Certainly, he used the precious help of his sister Serafina.

Dežman analysed the tabulated numerical values of the measurements, and not the graphs of annual changes in pressure and temperature, as Mitteis did in 1854. Dežman also did not mention Mitteis' 29-year-old paper about the same problems in his discussion. He also avoided to mention M. Wurner's analysis of the weather conditions in Jesenice, printed in 1872. Thus, for a more complete analysis of the Carniolan meteorological conditions, it was necessary to wait for another two decades. It was not until 1902 that Ferdinand Siedl (1856-1942), a professor at a higher real School in Gorizia, analysed temperature, humidity, cloudiness and precipitation measurements in Carniola in his 650-page book. Siedl studied the basics of meteorology with his Slovenian teachers. He attended a gymnasium in Novo mesto between 1863 and 1874, where Francis Bernard Vovk (Vovk) taught him physics in lower and upper gymnasium and mathematics in grades 7 and 8. Vovk led the meteorological observatory in Novo mesto between 1858-1885. Between 1874-1880 Siedl studied Natural history, physics and mathematics, at the University of Graz, where Simon Šubic lectured on meteorology.

30.2.6.5 Snegulka Detoni

The inner Carniolan (Notranjka) Snegulka Detoni later married Moljk (De Toni, 1921 Begunje by Cerknica-2016 Ljubljana) became the first assistant to professor dr. Anton Peterlin in 1944. She was born in a very affluent family a few kilometers north of Cerknica in a relatively remote Menišija of the village Dobec pri Krajncih by Begunje near the birthplace of Ivo Lah. She even excelled herself in glider sailplane sports in Bloke with her exam for a pilot included.

Snegulka's grandfather Vincenc de Toni (1851 Trelli near Paularo (Paulâr) in Friuli-1907 Begunje no. 24, later no. 39) migrated because he was dissatisfied with Italy of Risorgimento. He married the local Slovenian maid Frančiška (* 1859) and bought the farm of Cenc in Begunje. He became a prosperous innkeeper, trader, and butcher. He learned some Slovenian language and enjoyed the silent hunting with his eldest son and third child Toni de Toni (Anton, * 1884 Cerknica), Snegulka's father. Vincenc's next to youngest son Vincenc de Toni (* 1899) died in the war on

partisan side which enabled Snegulka's relative prosperity under communists.

Snegulka graduated from the Chemical Institute of the Faculty of Technology immediately before World War II. She completed her diploma work with Peterlin and graduated in 1944 as the first Peterlin's graduate student. She listened to mathematics at the Plemelj's class, and Physics at Peterlin's class, while she passed several exams. She might have been one of the reasons for the quarrels between Peterlin and Moljk, because the big ideas of Slovenian ideological quarrels always have in their fundament just two reasons: wine and females.

In the autumn 1945 she started her first job at the Bacteriological Institute of the Medical Faculty. At the invitation of Peterlin, she worked at the Department of Physics of the Faculty of Engineering since 1946. As the only assistant, she conducted exercises for all students of the Technical College, where she taught electrical engineers, machine engineers, miners, metallurgists, builders and surveyors: in total, about 250 listeners each semester. She also conducted exercises for students of the Faculty of Natural Sciences and Mathematics, where she taught physics, mathematics, chemistry, geology and meteorology to about eighty students each semester. For all those students she also prepared a written part of the exams in physics. She helped with experiments in physics classes.

She designed camera of Joseph Boussinesq's and Gabriel Lippmann's student turned professor of physics at the Catholic University of Angers (Université Catholique de l'Ouest) Maurice Marie Alfred Couette (1858 Tours-1943, Angers) for measuring the double refraction of flow (current, streaming birefringence) like Čopič. Her tool was supposed to be produced at the Mechanical Engineering Department of the Faculty of Engineering. However, their manufacturing was too slow. Nevertheless, she managed to prepare the measurements that Peterlin and Samec evaluated theoretically on September 1, 1944, when Peterlin was already in Dresden. They published their joint paper in the journal *KolloidZeitschrift* where Samec was always the closest collaborator, and Peterlin also published there his papers after the war; both Peterlin and Samec were members of the *Kolloid-Gesellschaft* which W. Ostwald

established in Leipzig in 1922. Their publication was later used as a pretext for Samec's penalization because of his alleged break of cultural silence ordered by OF, while Peterlin and Snegulka were not punished at all.

Snegulka used two Paul Glan-Silvanus Philipps Thomson prisms designed in 1880/81 for a polarizer and an analyzer. Possibly because of the lack of other chemicals, the extracts from potatoes were measured.

In 1954, Snegulka joined the Department of Structural Chemistry, where she completed her Ph.D. in the class of chemist academician Dušan Hadži with a hundred pages long dissertation on the structure of surfactants whose ultraviolet spectra and formulas she studied in 1956.

She was interested in the hydrogen bond research at Samec's Chemical Institute. In June 1957, an international symposium on hydrogen bonds was held in Ljubljana, where Snegulka participated in the organizational committee. The symposium was also attended by Professor Linus Pauling, the Nobel Prize winner in Chemistry in 1954 and the Nobel prize winner for Peace in 1963. Pauling offered Snegulka one-year scholarship to work in his department at Caltech in Californian Pasadena starting on 1 August 1957. This was a great honor and happiness. Unfortunately, Snegulka did not receive a Yugoslav visa for USA, although Professor Pauling was waiting for her for four years. Unable to reach USA, Snegulka went to Copenhagen university in 1958, like Črt Zupančič. Snegulka used the fellowship of Danish government. She researched the chemical compounds with microwave and infrared spectroscopy in the group of the former anti-Nazi resistance firefighter Børge Bak (1912-22 February 1990). In Denmark, she lectured twice on hydrogen bonding. At the same time she published three papers, together under supervision of the professor Bak and colleagues.

In 1960, Snegulka replaced prof. Hadži, who went for one year to America. She conducted the exercises about his thematic and participated in the experimental work with ferroelectrics with a group of professors Blinc at the Jožef Stefan Institute. In 1961 Snegulka together with prof. Blinc and colleagues received the Kidrič Prize for research of ferroelectrics with hydrogen bonds. She studied infrared and Raman spectra of organic molecules with S-O, Se-O, P-O and C-N bonds and organic

acids with strong and weak OH bonds and published important results. Since 1976 she lectured on infrared and Raman's in chemistry and technology to for postgraduate students of spectroscopy and X-ray analysis of polymers. At four international symposiums and congresses, she presented papers on hydrogen bonding. She has published a total of forty-seven papers in cooperation with professor Blinc's and professor Hadži's teams, or alone. She even participated with her works in two books published abroad. In 1979 she was habilitated in Ljubljana, and in 1980 she was elected an extraordinary professor. In the mid-1980s she published high-profile research on vibration spectra in collaboration with academicians dr. Hadži and dr. Ljubo Golič, a native from eastern Slovenia. Snegulka's work was so important that some of her achievements are still cited today.³⁴⁰⁶

The Detoni (De Toni) family was extremely rich, which was not the best recommendation in Slovenia of those times. The Inner Carniola was not the favorite of communists anyway. The communist connections of her uncle might have been an obstacle for Snegulka's USA visa.

In her advanced years Snegulka also collected the data for her family history. Snegulka lived during her last years in the home of the elderly citizens in Bokalce near Ljubljana like Vidav, but the clever Vidav survived there much longer. The legend tells that Snegulka kept the piece of Chicago nuclear reactor which Fermi personally gave to her as a present.

30.2.6.6 Bibiana Čujec Dobovišek, Nuclear Reaction and Religion

The development of the modern physics of small and fast took place in parallel with the establishment of a new University of Ljubljana, which finally offered many opportunities to the Slovenian physicists of both genders. Emilija Mlakar, married Branz, was the first woman to graduate from mathematics at the University of Ljubljana. She completed her studies in the pedagogical field of mathematics in 1928 as the

thirteenth Ljubljana graduate,³⁴⁰⁷ and she lectured at the classical gymnasium in Ljubljana. Among the physicists of Ljubljana, Bibiana Dobovišek (* 25 December 1926 Ljubljana) was born in the family of machine technician and clerk. Like Marija Wirgler and Ángela Piskernik, she also finished elementary school and high school at Ljubljana Ursulines' classes upon the end of the war.

Table 30-5: The first dozen women who finished their studies of physics and meteorology in Ljubljana until 1963

Name and surname	Date of diploma (supervisor)	Date of doctorate (supervisor)
Bibiana Dobovišek Čujec	1950 (A. Peterlin)	1959
Danila Nemeč (Meteorology)	1954	
Marija Robavs (Meteorology)	1954	
Milena Bevc (Meteorology)	1958	
Jelena (Alenka) Hudoklin Božič	1958 (Pedagogical)	1968 (M.V. Mihailović)
Cvetka Bartol (Pedagogical)	1958	
Alenka Kmecl (Meteorology)	1960	
Danica Burg Hanžel	1960 (A. Moljk)	1973 (A. Moljk)
Petra Beniger	1962 (I. Kuščer)	
Helena Velikonja	1962 (A. Hočevnar)	
Ana Rudolf	1962 (R. Blinc)	
Marija Simonič (Pedagogical)	1963	

After the German occupation, she studied under supervision of the professor Plemelj, Vidav and Peterlin from the autumn of 1945 onwards. From her personal inclination, she also listened to the first year of lectures on ancient Greek philosophy. After graduating in 1950, Bibiana worked for four years at the SASA Physics Institute, and then in its

³⁴⁰⁶ Notes of dr. Veronika Kralj Iglič on 16. 5. 2005 and 8. 10. 2005.

³⁴⁰⁷ D. Krstič, Mileva & Albert Einstein ljubezen in skupno delo. Didakta, Radovljica 2002, p. 100.

successor, the Nuclear Institute, today's Jožef Stefan Institute, from 1955 to 1966. She began by analyzing nuclear emulsions on photographic plates of the professor Sten von Fresen (1907 Uppsala-1996) of Lund University in Sweden which Fresen exposed out to cosmic rays at a height of 30 km, and then donated them to Ljubljana researchers. By measuring the ionization and the travelled distance, Bibiana calculated the mass of the meson K (kaon) newly detected in Manchester in 1947.

Bibiana studied photonuclear reactions on the new betatron of Darko Jamnik, which was purchased in 1954. It used to be the most accurate device for exploring a nuclear photoelectric effect in the energy range up to 30 MeV. That's why Bibiana's measurements were particularly pleasing. Jamnik graduated a year after Bibiana in the pedagogical direction of the studies of physics in Ljubljana, and they both received their doctorates in the same year after having completed all their studies in Ljubljana in 1955.

Bibiana first measured the reaction of carbon and oxygen nuclei in the emulsion, where the traces of alpha particles give characteristic three-pointed stars or four-pointed stars. These enable the determination of the energy of the photon that triggered the reaction, while giving a good insight into the course of the reaction. An interesting question was the "giant" resonance, which usually occurs at energies of around 20 MeV. It was not clear whether a collective excitation of the nucleus is involved, or the photon reacts with a nucleon, raises it to a higher energy level from which the photon can then emerge out of the nucleus or became absorbed back into the nucleus. Based on the shell model it has been shown that photon reacts with the single proton.

In 1959, Bibiana's study led her to the dissertation titled Photo-nuclear reactions with a special focus on Wilkinson's model, written in 204 pages. The dissertation was accepted in 1958, but she as the candidate had to make the oral exam (rigoroz). She completed it with the commission composed of Peterlin, Kuščer, and Črtomir Zupančič on 2 September 1959 as the date of her doctor's degree. The defense followed on September 24, and the promotion took place on November 24, 1959.

Maurice Hugh Frederick Wilkins (* 15 December 1916; † 2004), like Rutherford before him, arrived from New Zealand to become the successful British physicist. As a former communist at the University of California in Berkeley, he developed isotope separation for the atomic bomb, which disappointed him and directed him to the research of DNA. In 1962, he received a part of the Nobel Prize in Medicine and Physiology for his contribution to the discovery of DNA together with the Jewish phage group member Salvador Luria's (1912–1991) doctoral student James Watson (* 1928) who tempered his racist views only after LGBT girl Lori Lightfoot became one of many African American mayors of his native Chicago. Of course, the prize for the research of DNA should be earned by the agnostic Jewish physicist Rosalind Franklin, who, unfortunately, did not manage to get to the recognition because of her female disadvantage. By her X-ray diffraction pictures she discovered the full structure of the virus in 1955. Dr. Hadži invited Franklin to Slovenia several times, in 1952/53, and she enjoyed their Alpine tours including Bled, Triglav Lakes Valley and Triglav itself in May 1952.

Bibiana then proceeded to study photo-nuclear reactions of beryllium applied to nuclear emulsions. The transfer of a slightly bound neutron into ${}^9\text{Be}$ was carried out with an extremely high probability. She found out various reactions and determined the energy of photons that she triggered. She measured the spectra of protons emanating from the nuclei of silicon, phosphorus, and sulphur radiated at the betatron.

After her wedding, Bibiana took over her husband's surname Čujec and later gave birth to her three daughters and a son. Following the reorganization of the Institute IJS in 1960, she applied for the position of assistant and assistant professor in the physical department, but she wasn't successful. Therefore, in 1961, with the recommendation of Črt Zupančič, she went on to postdoctoral training in Pittsburgh. There she studied the nuclear structure with experiments on the cyclotron of the controversial theorist of cancer risk from low level radiation the professor Bernard Leonard Cohen (1924 Pittsburgh - 2012), which accelerated deuterons to 15 MeV. She measured the reactions (d, ${}^3\text{He}$) and (d, p) on different nucleus. To the other side of the sea she was followed by her husband and children.

In 1963/64 she moved with her family to nearby Canada. She lectured at Alberta University in Edmonton and measured the stripping reaction (d, n) with 5.5 MeV Van de Graaff accelerator. In the following year she went to Laval University in Quebec, where an accelerator of the same type was installed in 1963 and later expanded to 7.2 MeV. She stayed in Quebec until her retirement in 1993. She quickly mastered the French language and first detected deuterons through a magnetic spectrometer in nuclear emulsions. She studied nuclear spectroscopy during her measurements of nuclear reactions with deuterons. For more detailed study of nuclear levels (determination of spin, nature of electromagnetic transitions and lifetime levels), a more demanding technique was required.

In 1966, she was elected an extraordinary professor, and she became a full professor in 1970. Quick successes were her match. She also began to research astrophysics with the study of heavier nuclei. She spent the first two sabbatical years at the California Institute of Technology's Kellogg Radiation Laboratory in Pasadena, investigating nuclear reactions in the stars in 1971/72 and 1978/79. She spent her last sabbatical year in the CERN of Geneva in 1985/86, where the professor Bogdan Povh of Heidelberg accepted to participate in her measurement of collisions between protons and antiprotons. Today, Bibiana's daughter of the same name follows her as she chose cardiology for her profession. Bibiana's youngest daughter Ana Marija Čujec studied physics by mother's footsteps.

After the seventy scientific papers Bibiana Čujec the elder described for her Slovene readers her Catholic view of the world of physics in an interesting Slovene book in the year of physics in 2005. The preface to her successful book was written by an important Slovenian experimental physicist dr. Franc Cvelbar, also a devoted Catholic. She described the development of science with her physics included from ancient Greeks to modern times. She showed how much quantum mechanics had changed our view of the world with the principle of indeterminacy. Thus, despite her long absence, Bibiana was by no means alienated from the Slovenian people. On the contrary.

Dr. Danica Burg Hanžel studied at the Ptuj Grammar School in Ljubljana and graduated in March 1960 as the first Slovenian female physics engineer, the first graduate female Slovenian physicist outside the pedagogical direction and a 50th Slovenian graduate in "pure" physics. She had six classmates including Ančka Rudolf and the daughter of writer Narte Velikonja (1891-1945), Helena Klara Velikonja (1936-1991). Both those classmates graduated in 1962: Ančka researched paramagnetic matter with nuclear magnetic resonance under supervision of dr. Blinc, and Helena measured tensile strengths of glass welds with metals under supervision of dr. A. Hočevnar. Ančka later joined Iskra Elektrooptika in Stegne, and Alenka lectured at the Secondary Technical School in Ljubljana until her premature death. Danica was employed at the IJS and initially participated primarily under supervision of her supervisor, dr. Anton Moljk.

Two years before her diploma, the Munich native Rudolf Ludwig Mössbauer (* 1929) during the work for his dissertation discovered the resonant and recoil-free absorption of gamma rays in solid matter. He received a Nobel Prize while he continued his research at MIT in 1961. His discovery ultimately demolished the barrier between nuclear physics and physics of solid state,³⁴⁰⁸ and thus, at the experimental level, new vacuum techniques combined basic quantum research with useful studies of new materials. The promising novelty was particularly intriguing to Danica. Already before her doctorate under the supervision of dr. Moljk in 1973, she developed her domestic Mössbauer spectrometer for the research of magnetic properties, phase transitions and the electronic structure of iron-containing materials. With the new method she cooperated with several IJS laboratories and with German and French researchers. She has published over a hundred works. Therefore she received the prestigious Boris Kidrič Foundation Award in 1978.

³⁴⁰⁸ Note of Master of sciences Djordj Krstić (* 1936 Novi Sad; † 2014 Kranj) on 16. 5. 2005 and dr. Danica Burg-Hanžel on 15. 9. 2005.

30.2.6.8 Conclusion

Vacuum technology has directed the development of modern physics in the last century. They were developed in parallel with the entry of the first academically qualified female and non-white physicists into research. It is therefore not surprising that the first Slovenian female physicists were particularly active in introducing vacuum experimental techniques into science.

30.2.7 Nanotubes

30.2.7.1 Introduction

Every great discovery hides its small prehistory. It is the same with the first inorganic nanotubes that were assembled in Ljubljana two decades ago. Like nanotubes, which they grew for twenty-two days in the Laboratories of the Jožef Stefan Solid State Department, the knowledge needed for their invention have been accumulated in Carniola for two centuries. The story begins with Hacquet's pioneering microscopy of crystalline structures at the end of 1776 at the premises of today's Ljubljana market in Vodnikov trg, from where the lyceum was removed after the earthquake.

30.2.7.2 Crystalline Tubes of Professor Hacquet's Hard Rime in Ljubljana

Naturalist Hacquet studied hard rimes on his window in Ljubljana Gornji Trg above Hercules' fountain in former Jesuitical apothecary. Later, he recognized similar forms at the University of Lviv (Lvov, Lemberg) in apparently inanimate ice-frost flowers.³⁴⁰⁹ The hard rimes tracery on Hacquet's frosted window used to be one of the bravest moments of Hacquet's research. He watched the flowers from his study room a year and a half after coming from Ljubljana to the University of Lviv. They were mounted on his 60 cm wide double window looking north-north-east.

Hacquet argued that many observations of ice have not yet convincingly explained its various crystalline forms. Among the predominant hexagonal (six angular) forms, he observed prisms and pyramids with four or six faces through his microscope. In Linnaeus's way they were sorted by the shapes of the basic surfaces of their crystals.

The arranged structures were intertwined with stacks of broken pillars and hollow tubes.³⁴¹⁰ These tubes were extremely small for Hacquet's time, although thousands of times wider than modern nanotubes. Times change and with them the perception and observation of the smallest distances.



Figure 30-60: Hacquet's sketch of ice flowers in hard rime (Hacquet, 1790, fig. A, Tab I).

Hacquet rejected the possibility that salts of bases formed in plants could have an impact on the formation of ice in his hard rimes. In the new year of 1789, he was warming up in his workroom, while the outside was a wet weather accompanied by the northern wind at a temperature of -19°C to -24°C (-15.5°R to -19°R). With a 4 mm thick barometer, full of Idrija mercury, he measured a pressure of 0.94 bar. He noted lengths in the elbows (hoods) measuring 114.3 cm. He wrote his smaller distances in inches (cols, "). The 26.33 mm long (today just 25.4 mm) inch contained 12 lines ("). He recorded the temperature in the degrees of Frenchman René Antoine Ferchault de Réaumur (* 1683; † 1757), like most of the then researchers; among them Gregor Schöttl and Hacquet in their meteorological measurements published in 1776 in Ljubljana, Gabriel Gruber a decade later, and even Dežman a century after them.

³⁴⁰⁹ Hacquet, 1790, 27.

³⁴¹⁰ Hassenfratz, 1789, 34, Hacquet, 1790, 20.

Hacquet has outlined the forms of ice flowers in hard rime from his window. He carefully observed the formation of long needles from crystals of ice. He compared them with sketches of the mathematician Giovanni Francesco Melchior Castillon (* 1708; † 1791), rector of the University of Utrecht, who became the member of mathematical class of the Berlin Academy in 1751. In February, the needle ice frost flowers on the Hacquet window changed considerably. On the sides they developed symmetrical hard rime resembling living beings of a similar shape. Likewise, modern researchers describe their observations of the growth of nanotubes.

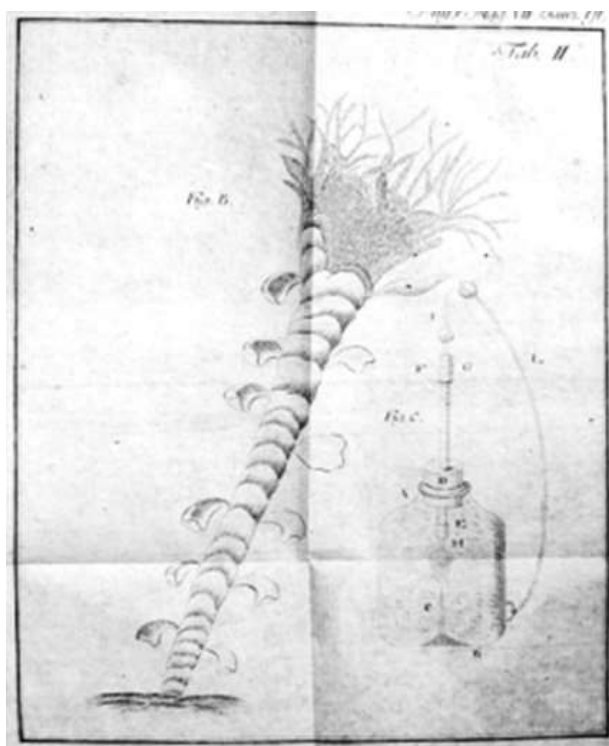

Figure 30-61: Hacquet's sketches branched in a tube of joined ice flowers in hard rime on his window (Hacquet, 1790, fig. B, Tab II).

On the upper edge of an ice flower, Hacquet spotted an open hose with its rings resembling the spring. Many pores inside his iced flower reminded him of the perforated marine polyps. On 7 June 1676 similar forms were observed in Altdorf on grains of hail.³⁴¹¹

At his frosted flowers Hacquet recognized all three kingdoms of nature: animals, plants and crystals as intermediate films like viruses, liquid crystals or aperiodic order of Islamic and African ornaments-

³⁴¹¹ Hacquet, 1790, 25.

architecture chaos quasicrystals borrowed by Fibonacci were mostly not discussed among westerners of those times. The branched ice reminded him of the trees. Similar ideas have been developed by Dr. Friedrich Casimir Medicus (* 1736; † 1809) two decades earlier. He was an important advocate of vitalism, since he first used the concept of life force in 1775. In 1764 he became a garrison doctor in Mannheim and a member of the Academy of Sciences of the city. Four years later, he described the structure of hard coal (anthracite) comparable to Hacquet's icy frost flowers.

Hacquet used the explorations of the icy flowers of hard rime of Johann Gottlieb Gleditsch (* 1714; † 1786), the count Georges Louise Leclerc de Buffon (* 1707; † 1788), the Calvinist doctor Jean F. Reynier (* 1730) from Lausanne near Lake Geneva as the father of the physicist-pharmacist researcher of similar crystals Jean Louis Antoine Reynier (1762 Lausanne-1824 Lausanne) and the Napoleonic general Jean Louis Ebénézer Reynier (1771 Lausanne-1814) who both joined Napoleonic Egyptian expedition. The Hamburg native Johann Heinrich Müller (* 1671; † 1731) also provided such data as the professor of mathematics and physics at Altdorf University. Hacquet's friend Andreas Sigismund Marggraf (Marggraff, * 1709; † 1782) systematized an ice flower of hard rime into the "kingdom of rocks with plant forms". In 1738, the king Friderik Wilhelm I (* 1688; † 1740) named Marggraf a Berliner academician. After sixteen years he was promoted to the head of the academic chemical laboratory and finally he became the director of the physical class of the academy in Berlin in 1760. In 1747, he used the microscope to develop a method for obtaining sugar from sugar beet. This was probably the first chemical identification with a microscope,³⁴¹² which soon became the basic tool of Hacquet's research.

Hacquet wrote about the hard rime to Johann Heinrich Voigt (* 1751; † 1823). Voigt published Hacquet's letter and supplemented it with his own observations. In 1774, Voigt began to teach in gymnasiums in Gotha, where he published the astronomical part of the court calendar. Between 1786 and 1799 he took over the editing of the Journal of novelties about Physics and Natural

³⁴¹² Tišler, 2003, 73.

Sciences (Magazin für das Neueste aus der Physik und Naturgeschichte together with Georg Christoph Lichtenberg's elder brother Ludwig Christian Lichtenberg (* 1737; † 1812 Gotha). In 1789, Voigt received a PhD from philosophy at the University of Jena, where he took over the department of mathematics, and he also took over the chair of physics for thirteen years. After 1797, he published twelve papers about the latest research on nature in the journal printed in Jena. He wrote papers about mathematics, fire, air, electricity, magnetism, optics, comets and the history of the calendar. Among his friends were Hacquet and his enemies the brothers Gabriel and Tobias Gruber; so, he published and evaluated their works.

Hacquet read interesting descriptions of hard rimes ice flowers in French magazines. On 13 July 1788, his attention was drawn to St. Mauritz, three French miles east of Paris. The grains of conical shapes with diameters of 79 mm and lengths of 6.6 mm were made up of octahedrons and pyramid crystals. Horace Bénédict de Saussure (1740-1799), a professor of philosophy, studied ice flowers on the window of his office at the Geneva Academy, where he lectured from 1762 to 1784. In the meantime, he studied alpine glaciers. In 1787, he first climbed to the top of Mont Blanc and therefore followed Hacquet, who climbed on the top of Triglav on 8 August 1779. We do not know if both famous mountaineers met at one of the Alpine peaks; in any case, Hacquet measured with the Saussure barometers on his Lyceum in Ljubljana. Saussure invented a special hygrometer on the hair that he put under the bell. The air quality was determined by the nitric oxide eudiometer, which they had for the equally important instrument as the thermometer or barometer during those times. His son Nicolas Théodore de Saussure (1767-1845) explained the work of photosynthesis discovered in 1779 in Vienna by Hacquet's "teacher and friend", the Dutchman Jan Ingenhousz (1730-1799), just before Jan returned to London.

30.2.7.3 Molybdenum and Tungsten in Ljubljana

In Hacquet's time, the name molybdenum barely began to be used for special metal. In nature, molybdenum is rare in its pure form, so it was not distinguished from graphite and similar minerals

two hundred years ago. According to Scheel's advice, Peter Jacob Hjelm (* 1746; † 1813) used a procedure like Gahn's isolation of manganese from its oxide in Stockholm in 1781. Johann Gottlieb Gahn (1745-1818) was the assessor of mines at Fahlun in 1770, and chemist for the Swedish Board of Mines called Bergskollegium from 1773 to 1817. As a practical miner Gahn did not publish his scientific findings himself, but freely communicated them to the professor in Uppsala Tobern Bergman's (1735 Katrineberg-1784 Medevi) and his protegee Scheele, which also benefited Hjelm in the times when the military fame of Swedish king fighter Gustav Adolf was over for good, but the Swedish metallurgy with their very pure iron ore was still in its summit. Thus, Hjelm succeeded in isolating the previously unknown metal, molybdenum, as its discoverer Hjelm's fellow Swede Karl Wilhelm Scheele (* 1742; † 1786) happily wrote to Hjelm on 16 November 1781. Of course, the first molybdenum was not particularly pure, until Berzelius separated a better one later.³⁴¹³

Shortly after Hjelm's success, the Spaniard Don Fausto d'Elhuyar (1755; † 1833) discovered tungsten in 1783. The new metals molybdenum and tungsten were soon acquired for the Ljubljana Lyceum collection, so that professor Kersnik listed them in his cabinet as early as in 1811.

30.2.7.4 Crystal Symmetry of the Ljubljana Professor Schulz von Strassnitzki

Schulz von Strassnitzki was the most important professor of mathematics in Ljubljana until the twentieth century. Shortly before his arrival in Ljubljana, he published a book about a rectangular triangle and three-sided pyramids as an introduction to his crystallographic studies in Vienna in 1827. He devoted his work to Andreas Joseph baron Stiff like Neumann before him, and in his discussion, (he referred mostly to Lagrange's analytical solutions to the problems of the three sided pyramid (tetrahedron, 1783). At his first twenty-eight pages, Schulz first presented the historical background of studying triangles from Thales to Euler.³⁴¹⁴ In the second part devoted to the three sided pyramid (tetrahedron), Schulz

³⁴¹³ Diogenov, 1960, 169.

³⁴¹⁴ Schulz, 1827, 5.

Karol (Leopold) Schulz Edler von Strassnitzki was a professor of mathematics in Ljubljana between 1827 and 1834. During his service in Ljubljana, Schulz published five books and even more important scientific discussions on crystallography and mathematics; after leaving Ljubljana, despite his premature death he published another eleven books. His best students in Ljubljana were

Franc Močnik and Mihael Peternel. Before the reform, Schulz taught seven hours of mathematics a week in German language according to Appeltauer's textbook of theoretical mathematics, which was also used elsewhere in the monarchy, including at universities in Schulz's native Galicia and Olomouc, where Schulz's pupil Močnik later taught. Schulz's father Anton was the first district commissioner of the Galician countries, while his mother Carolina died when he was an eight-year-old boy. Together with brother Joseph, they went to Vienna, where their paternal grandfather Leopold Ludwig took care of them. He served as a professor of political sciences, a political writer, district chief and a counsellor of the guberniya. Unfortunately, the grandfather died after a long illness two years after he took over the care for his young grandsons; he certainly left a great impression on them. Karl Schulz finished high school as the best in his class. In the last year, he told his teacher that he would like to become a mathematician and a teacher according to his grandfather's example. In those days at Viennese three-year philosophy faculty, they had a college of mathematics and astronomy with professors Ettingshausen, Littrow, former Ljubljana professor dr. Josef Jenko and the philosopher Leopold Rembold dismissed for his alleged atheism in 1825, like Bolzano before him. Among Schulz's high school colleagues-classmates was a later professor, ministerial councilor, philosopher and reformer of schools dr. Franz Exner (1802-1853) and poet J. B. Seidl. Rembold's students F. Exner later taught Josef Loschmidt at the Prague High School. In 1891, Loschmidt's successor in the management of the Viennese Physical Institute was, the son of F. Exner the crystallographer Franz Serafin Exner (1849-1926).³⁴¹⁵

referred to the August Leopold Crelle's (1780–1855) Berliner collection of mathematical expressions and observations published in 1821.³⁴¹⁶ Considering his previous findings about triangle, Schulz calculated the equations for the center of gravity of the pyramid for the sphere circumscribing the pyramid and for the coordinates of the center of gravity of the pyramid.³⁴¹⁷ Schulz's booklet was an expanded reprint of two papers that he simultaneously published in Baumgartner's and Ettingshausen's Viennese magazine.

Schulz was, of course, the best in mathematics among almost three hundred classmates. On 22 March 1823, Jožef Jenko from Kranj organized an annual disputation, where Schulz successfully defended several mathematical theses. At first, Jenko taught mathematics at the Ljubljana Central Schools, but he suffered from unhappy love with a girl who preferred Jenko's wealthy student. So, he resigned in favor of Kersnik and went to the University of Graz on June 14, 1810. After the death of Franz Jeschowsky on 29 April 1814, he took over the lectures of mathematics, and on 24 November 1814 he lectured the technology at Joaneum. On December 13, 1819, with Ž. Zois's recommendations, Jenko went to Viennese University³⁴¹⁸ where he became best friend of Jernej Kopitar who eventually passed away in Jenko's house.

Schulz learned the history in the class of professor and librarian Martin Johann Wikosch (1754 Uherský Brod (Ungarisch Brod) in Moravia-1826 Vienna). By the decree of the Provincial Government no. 691 of 17. 1. 1823, Schulz received a mathematical scholarship of 300 florins, and at the same time he became an adjunct under supervision of the professors Baumgartner, Jenko and Ettingshausen under act no. 43.605 issued on 13 September 1824. On 9 November 1824, Schulz became a mathematician and physicist, while his brother Josef received his doctorate of jurisprudence and became a financial adviser.

In 1827, Karl Schulz received a simultaneous offer from the Lyceums in Ljubljana and in Salzburg.

³⁴¹⁶ Schulz, 1827, pp. 31-100, mostly on p. 52.

³⁴¹⁷ Schulz, 1827, 100.

³⁴¹⁸ Krones, 1886, 137, 290. During his Ljubljana employments, Jenko used to borrow books from Zois' library (Svoljšak, Vidmar, 2019, 33).

³⁴¹⁵ Stiller, 1989, 48, 67.

However, the authorities rather invited the assistant Adam Burg to the chair in Salzburg, and Schulz came to Ljubljana on 13 June 1827. Professor Jenko almost certainly described him that small town by the Ljubljanica riverbanks. During his first three years Schulz was a Ljubljana adjunct and substitute (suplent) teacher, and later he taught as a professor.³⁴¹⁹ Littrow confirmed Schulz's curriculum and highly praised him; Schulz's lectures were approved by the highest decree on 24 January 1829. Schulz's mathematical lectures in Ljubljana were highly evaluated by his pupil, later school supervisor Močnik, in his letter dated 28 October 1853. The naughty students especially liked Schulz's jokes during lectures. In the summer months Schulz invited students even to domestic celebrations. In 1830, a professor of sciences Schulz married Antonia's daughter Sophia Selinger (Sofie Seeliger, Zeillinger, Zeilinger, Seliger) in Ljubljana. Their eldest son Johann Nepomuk Paul Friedrich (* 6. 7. 1831 Ljubljana) became secretary of state in the Ministry of Agriculture, their younger son Franz Leopold (* 1835) was a sectional adviser at the interior ministry (Ministerialsekretar) and married governorate counsellor Johann's and Kristine von Canal's daughter Natalie baroness Grimbschitz (* 1845) in Ljubljana with his brother Johann as his best man on 1 May 1871. Karl Schulz's third son Friderik was an engineer at the Western Railway. Despite a relatively short stay in white in Ljubljana, Schulz von Strassnitzki completely adapted to Slovenian local circumstances and even became a member of the Carniolan Agricultural Society. He resided in Ljubljana in Poljane (Polan) no. 23.

Like Močnik's teachings, Schulz's lectures praised by the then Governor of Illyria, Josef Camilo baron Schmidburg (1779 Graz-1846 Vienna) according to act no. 3958 in his letter to the study court commission on 11 August 1832. Schulz extraordinary lectured at the two-year higher mathematics course and at the one-year course of popular astronomy in Ljubljana between 1829-1834. The astronomy was among the optional subjects at the Ljubljana semi-university according to the syllabus of 1824. In addition to numerous students from all classes, Schulz's lectures of astronomy were attended by many citizens, elderly

people, women, girls, and even the poet France Prešeren (1800-1848) who wrote his funny poem about star-observers.



Figure 30-62: Ljubljana crystallographer, mathematician and astronomer Schulz von Strassnitzki (Huber, Karl, 1879. Schulz von Strassnitzki, *Ein Lehrerleben aus österreichs Sturm-und-Drang Zeit*, Wien and Leipzig: Julius Klinkhardt (NUK-36951))

Schulz' predecessor from the areas of the modern Slovenia might have been Tartini. At Schulz' times shortly before his death Giuseppe Tartini of Piran wrote a manuscript about Plato's circles connected the music intervals. He discussed five Plato's regular polyhedrons with a special concern about the pentagon.³⁴²⁰ Shortly before his death in the manuscript describing Plato's circles, the Piran native Giuseppe Tartini tied up his music with four regular polyhedrons, among them mainly with Plato's pentagon. He considered three Plato principles: the nature of the whole, the nature of diversity and substance. Although Schulz was a liberal guy and opponent of Cauchy's politics, they complement their research. Researching the regular polyhedrons also opened a new science for Schulz, the crystallography. In 1835 Schulz participated as a lecturer in Ljubljana in one of the leading

³⁴¹⁹ Schematismus Laibacher Gouvernements Königreichen Illyrie für das Jahr 1834, page 155.

³⁴²⁰ G. Tartini, *Scienza Platonica fondata nel Cerchio*, Cedam-Casa Editrice Dott. Antonio Milani, Padua, 1977, 1, 8, 11, 70, 94, 161, 277, 279, 309, 385, 399, 439, 443.

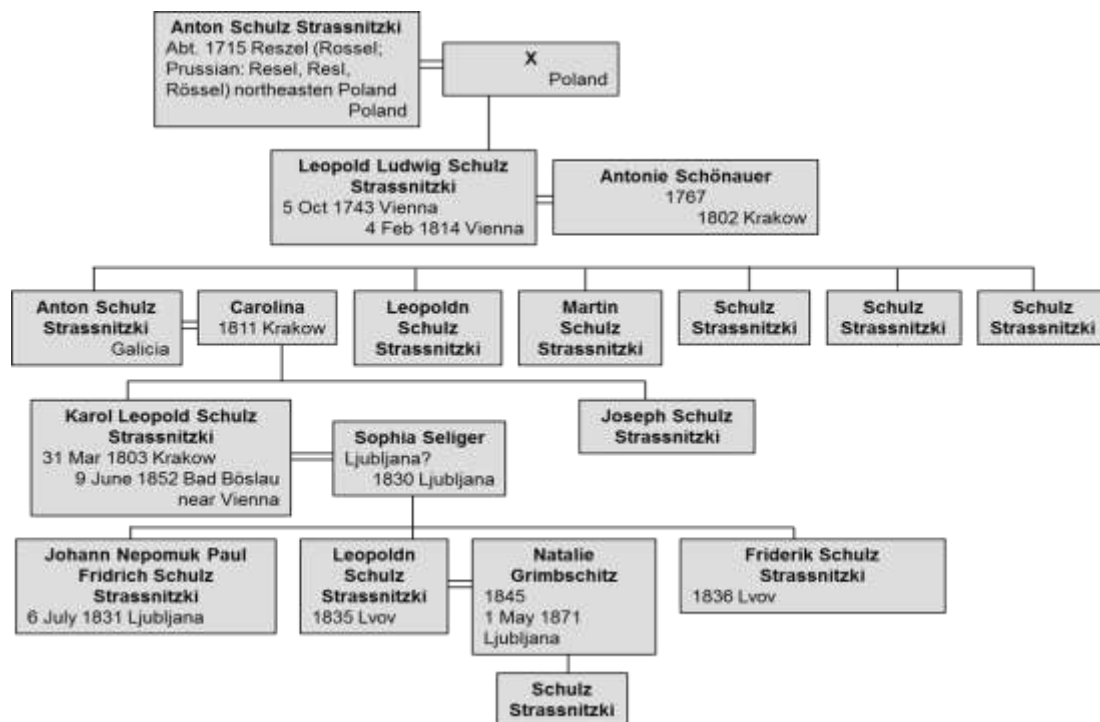

Figure 30-63: Ancestors of Ljubljana professor Schulz Strassnitzky

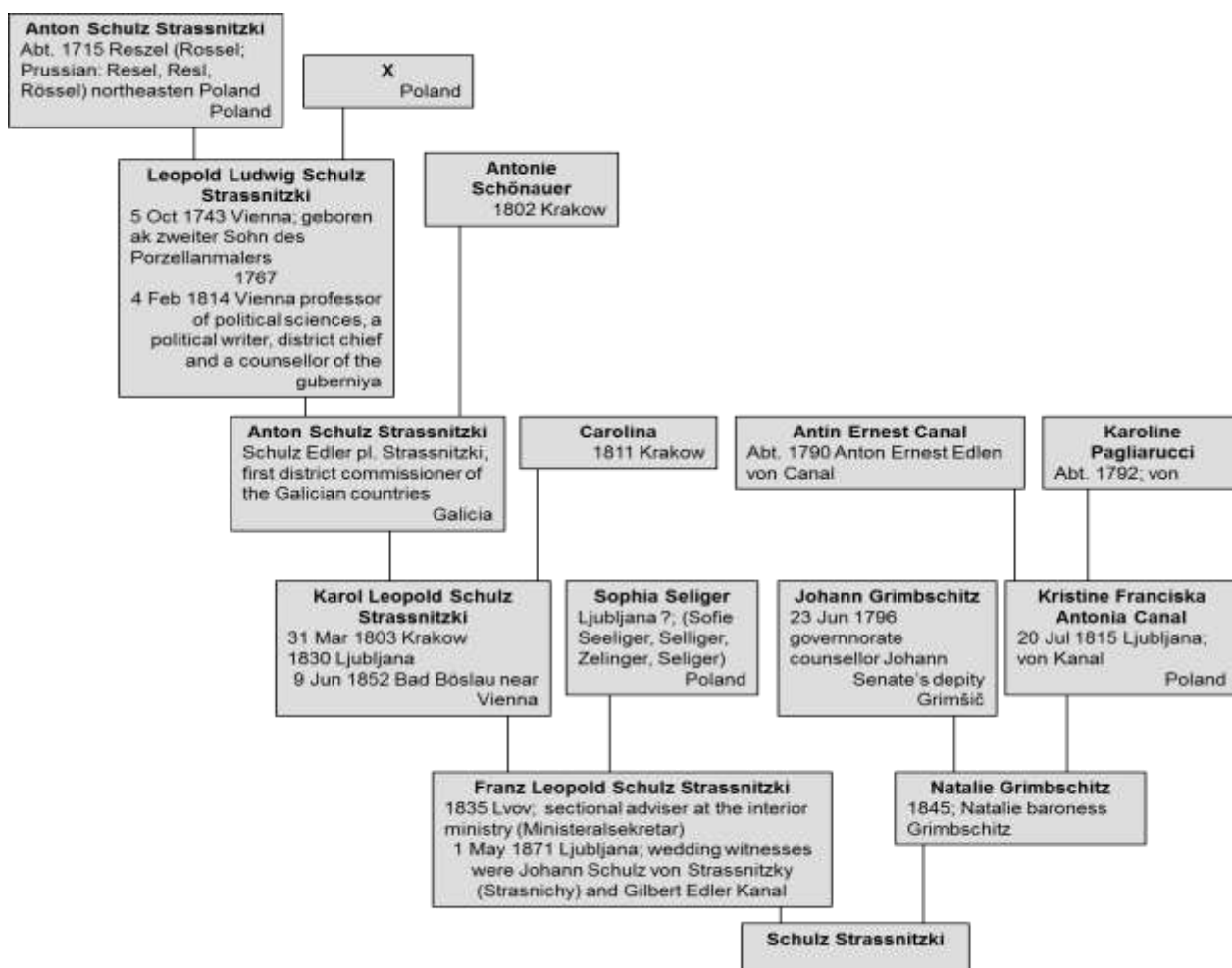

Figure 30-64: Ancestors of Schulz Strassnitzki and his son married in Ljubljana

mathematical journals' discussion of the exceptions to Euler's theorem about polyhedron. The operative part of theorem was discovered by Descartes and was described by Leibniz afterwards. However, in 1750 and 1752, Euler explained it in modern form:³⁴²¹

$$\text{The number of angles of polyhedron} + \text{number of sides} = \text{number of its edges} + 2$$

The impeccable evidence of a general proof was posted only by the young Cauchy in the year 1811/12. The survey was based on Plato's five regular polyhedral bodies to which the clever Kepler added two other non-convex dodecahedrons in 1619. In 1809, Poincot adjoined a further pair, great dodecahedron and great icosahedron. In 1811/12 Cauchy proved that it is possible to correct both Poincot's solids as they are stellated forms of the dodecahedron and icosahedron. In September 1832 in Ljubljana Schulz demonstrated that Euler's theorem applies to all geometrically simple bodies. He noted the description which physician and professor of mineralogy Johann Friedrich Christian Hessel (1796-1872) extended to more complex bodies of compound (double) crystals for which Euler's theorem is not valid. Finally, Schulz derived Euler's theorem from the more general Cauchy's ideas. Schulz' paper was the crown of multilevel debates about the Eulerian disposition in Crelle's Berliner magazine, which began with the anonymous publication Remark about a polyhedron (Bemerkung über ein Polyeder) in the year 1828. Cauchy and Legendre complemented Euler rule regarding the number of edges. In 1828, Dr. Hessel from Marburg described more polyhedral whose properties are not consistent with the Euler rule. Hessel has relied on Häüy's crystallographic research, published in German translation "Zwölfrautenflächers aus dem Würfel; treppenartige Kochs alztrichter usw". In 1830, Hessel in his article published in Johann Samuel Traugott Gehler's (1751 Görlitz-1795 Leipzig) Physics Dictionary (*Gehler's Physikalische Wörterbuch*) and in his books printed next year in Latin translation in Marburg and republished in German language Leipzig with Häüy's acquaintance Leopold Gmelin's (1788-1853) additions derived from the Häüy's dynamic tradition of crystallographers. The German

practitioner Hessel was far from Cauchy's more theoretical French background, while Cauchy's fan Bravais developed similar ideas independently in structurally theoretical tradition in 1849.



Figure 30-65: The introductory page of Schulz's Ljubljana discussion on polyhedrons (Schulz von Strassnitzki, Karol. 1835. Beitrage zur Discussion des Eulerschen Lehrsatzes von Polyëdern und Beziehung auf die neulich bemerkten Ausnahmen desselben. Journal for Reine und Angewandte Mathematik (Berlin, ed. AL Crelle) 14/1: 83).

According to his criticism of Hessel, Schulz was also directed against Bošković's dynamic atom, just like Bravais. Certainly, Schulz' work in Ljubljana was the beginning of mathematical crystallography there and in all Habsburg monarchy after Leopold Gmelin fled to Joseph Franz von Jacquin's Viennese University headquarters in March 1811 when Karol Leopold Schulz Strassnitzki was still a kid. The new geometrical crystallography soon found its foundation in Galois' group theory, but the conservative Cauchy during the life of Galois may not have supported Galois due to Galois' extreme political positions in Paris during the July revolution.

³⁴²¹ Euler, letter mailed to Goldbach in the year 1750; Euler, 1758, 109-140; Cantor, 1901, 3: 556.

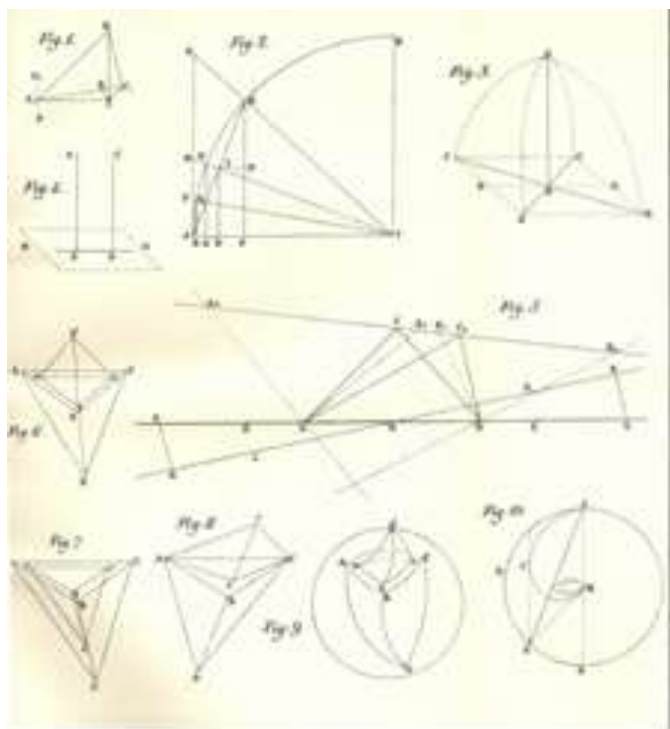

Figure 30-66: Images from Schulz's Ljubljana discussion on Polyhedrons (Schulz von Strassnitzki, Karol, 1835. *Beitrag zur Discussion of Eulerschen Lehrsatzes von Polyedern und Beziehung auf die neulich bemerkten Ausnahmen desselben*. *Journal für Reine und Angewandte Mathematik* (Berlin, ed. Crelle) 14/1: 381 (Table I, Figures 6-9).)

In September 1832 Schulz proved that Euler's theorem holds for all geometrically simple bodies. He replied to Hessel's description of moved or extended complex structures for which Euler's theorem did not apply.³⁴²² Finally, Schulz derived Euler's theorem from the more general Cauchy's theorem.³⁴²³ Schulz's discussion was the crown of multiannual polemics about crystallography and polyhedral in the Crelle's Berliner journal where Gauss, NH Abel and CGJ Jacobi also published. Schulz and Hessel continued the early exploration of the crystal symmetries of Haüy³⁴²⁴ started in Paris in 1784.

In 1809 William Hyde Wollaston and after him Romé de l'Isle invented a contact optical goniometer. It used reflection to accurately determine the angles in the crystal.³⁴²⁵ With that tool, the science of crystallography was born

³⁴²² Schulz, 1835, 87.

³⁴²³ Schulz, 1835, 85.

³⁴²⁴ Abbé René Just Haüy (* 1743; † 1822).

³⁴²⁵ Eckert, Schubert, Torkar, 1992, 21; Senechal, 1995, 13; Rezanov, 1988, 30; Hauptman, 1989, 24.

because there is no real science without new tools, journals, textbooks, and meetings on its behalf. The researchers have identified the correlation between the surfaces and the chemical composition of the crystal. In 1845, in the labs of Ljubljana Lyceum, Kersnik listed two Baumgartner hand goniometers for reflection; they acquired the first for a price of 33 florins 60 kreuzers. The goniometer was completed by the Welsh William Hallows Miller (* 1801; † 1880 Cambridge) in 1874, while the descendant of Geneva watchmakers of the dynasty of local horologist family Bobinet added a binocular to it for more detailed observations of the smallest crystals.

In 1849, Breithaupt's theory of paragenesis limited Haüy's excessive claim that every chemical substance develops only one crystal structure. In 1852 Breithaupt's theory was supported by CS Weiss and Berzelius' PhD student Gustav in the direction of the systematic classification of minerals based only on chemistry and crystallography. Haüy's connection of crystallography with geometry stimulated the Parisian professor of physics Bravais³⁴²⁶ who described the mathematically precise arrangement of crystal molecules. In 1850 Bravais proved that only fourteen different crystal networks were possible. Bravais was a naval officer, botanist, mineralogist, researcher and more. His papers were presented by Cauchy to the Parisian Academy. One of the most important crystallographers of the next generation, the Russian Evgraf Stepanovich von Fedorov, was also an officer. In 1891 Fedorov's later friend of the Jewish genus Arthur Moritz Schoenflies (* 17. 4. 1853 Landsberg (Gorzów) in western Poland; † 1928) under the influence of Felix Klein independently published similar Fedorov's theory of 230 groups based on Galois's premises. Fedorov also explored the growth of crystals.

Ernest-François Mallard (1833-1894 Paris) developed the theory of modern crystallography in 1874. He relied on Bravais' data. Leonhard Sohncke (1842-1897 Munich) presented the theory in his dissertation with sixty-five correct crystalline space groups to explain the degree of symmetry in 1879. Bravais's arguments about the exact arrangement of crystalline molecules were advantageously used to study the scattering of X-

³⁴²⁶ Auguste Bravais (* 1811; † 1863 (Senechal, 1995, 17, 19)).

rays on crystals in the 20th century. Of course, it took several decades before practical crystallographers accepted Galois' mathematical theory of groups as the basis of their much more practical science. Certainly, the effort paid out.

Schulz's interest in crystallography in the Carniolan capital was by no means a coincidence. Carniolans followed the development of the research of new materials in the Habsburg Monarchy, where, among other things, Josef Jacob (Jacobs) and Franz Köller (Koeller) acquired the tungsten steel in Reichraming in the district of Steyr-Land in the Upper Austria in 1855, tested it at the Viennese Polytechnic Institute in 1856, and patented their process in France in 1855 and in Vienna on March 10th, 1858. The former student of Viennese Polytechnic, head of Zois's iron works in Bohinj the technical director of the Carniolan industrial company (KID) knight Lambert Pantz (* 18 August 1835 Tržič; † 3 February 1895 Fieberbrunn in Tyrol) as the first in the world produced 37% ferromanganese in the Javornik blast furnace as first-class surprise in the world of technology. Scheele discovered the manganese in 1774 while the Carniola natives discovered a rich manganese ore a hundred years later in 1872 at Begunjščica river. Pantz's city of Jesenice was recognized with an honor of the invention of the first ferromanganese process, while the Javornik ferromanganese received a gold medal at the Viennese World Exposition in 1873 as the best and richest. It received an award in the form of a diploma at the international exhibition in Philadelphia on the centenary of the United States on September 27, 1876.³⁴²⁷ Lambert Pantz's success was not accidental because already his father worked as Sava suburb of Jesenice ironworks administrator (Verwalter) together with Viktor Ruard (1814 Stara Sava by Jesenice-1886 Stara Sava) in 1843. In 1836 Viktor married Ana Atzl, the daughter of the manager of the manor in Tržič Josef Atzl (1780–1873) and Theresia Atzl who were godparents of Lambert Pantz's brother Johann Emil Pantz in Jesenice on 16 March 1828. In 1825-1829 Lambert Pantz's uncle Ignaz Vitus Engelbert von Pantz was the director of Prince of Auersperg ironworks in Dvor (Hof) in Carniola where Ignaz Vitus Engelbert Pantz's son Eduard knight Pantz trained as a practice in 1825. The collaborations among predominantly Slovenian Inner Austrian metallurgists was vivid. Those

³⁴²⁷ Lačen Benedičič, 1999, 76-77.

traditions survived by Tržič areas native A. Paulin and the son of his classmate Matjaž Ravnik. The use of manganese, molybdenum and tungsten in Carniola lasted for two centuries, although initially those metals aroused interest only because of the high melting point. Few decades ago, molybdenum was finally used to greater extent in the steel industry.

30.2.7.5 Molybdenum and Tungsten in Early Vacuum Technique

Because of the high boiling point, molybdenum and tungsten quickly used in vacuum techniques. Langmuir developed a method for exploring discharge in gases with a thin charged probe made from refractory metals with high melting points such as tungsten or molybdenum. An adequate tiny probe did not perceptibly change the distribution of tensions in plasma.

The later mayor of Zagreb Franjo Hanaman (* 1878 Denovac in the county of Županja; † 1941) together with dr. Aleksandar Just patented tungsten lamps in Germany in April 1903. They were much more economical than carbon filaments, but unfortunately quite fragile. The production began in 1909 and soon showed the advantages of tungsten compared to the Osram.

Initially many researchers did not believe in the future of Ruska's electron microscope where smaller wavelength of electrons increased the resolution of the device, but at the same time it increased the energy of the electrons that destroyed the observed sample and molybdenum grids. The prospects seemed to be helpless. Today, molybdenum is widely used mainly in the form of MoS₂ for desulphurisation of petroleum, lubricants, solar cells, photocopiers and batteries.

30.2.7.6 Ljubljana Nanotubes

Dr. Velibor Marinković has been researching the layered crystals of molybdenum dichalcogenides and other transition metals in the IJS Laboratory for electron microscopy over three decades including his dissertation in 1965, and his discoveries were supplemented by his helper Maja Remškar. She investigated inorganic nanotubes, which she synthesized for the first time at the Jožef Stefan Institute with the technical assistance of Zora Škraba two decades ago.

Sumio Iijima (* 2. 5. 1939) studied in Tokyo and Sendai. Between 1970 and 1982 he studied crystalline substances with high-resolution electron microscopes at the State University of Arizona, and in 1979 he visited Cambridge University. Upon his return to his native island, he worked with a Japanese research development company until 1987, then at the NEC in Tskubi near Tokyo, which he has been coordinating with his lectures at Meijo University since 1999. After publishing the discovery of nanotube on November 7, 1991, he needed a dozen years to market his invention used in laptop computers, lightweight tennis equipment and computer components.)

discovered carbon-like "tubes like needles" in 1992, only a few months after Iijima.

Dr. Maja Remškar prepared the tubes differently than Tenne. For the first time, MoS₂ crystals were observed at the Jožef Stefan Institute in 1995 and they immediately detected their special useful features. They found that the diffraction image at the ends of the needles of MoS₂ differs from the image from the central parts of the nanotube. The diameter of needles was only a few micrometers but they were permeable to the old Philips 300 digestive electron microscope at 100 keV at her disposal. The diffraction image did not change during rotation of the needles of the MoS₂ around their axis, which testified to the enviable symmetry of unusual hollow tubes. The new discovery appeared on the Ljubljana horizon, although Slovenian researchers were initially unaware of the achievements of Tenne. This gave them a lot of advantage, since the nanotube in Ljubljana would

Due to the great attention focused on carbon nanotubes, inorganic nanotubes from MoS₂ and WS₂ were somehow squeezed away, although Reshef Tenne from Weizman's institute in Israel

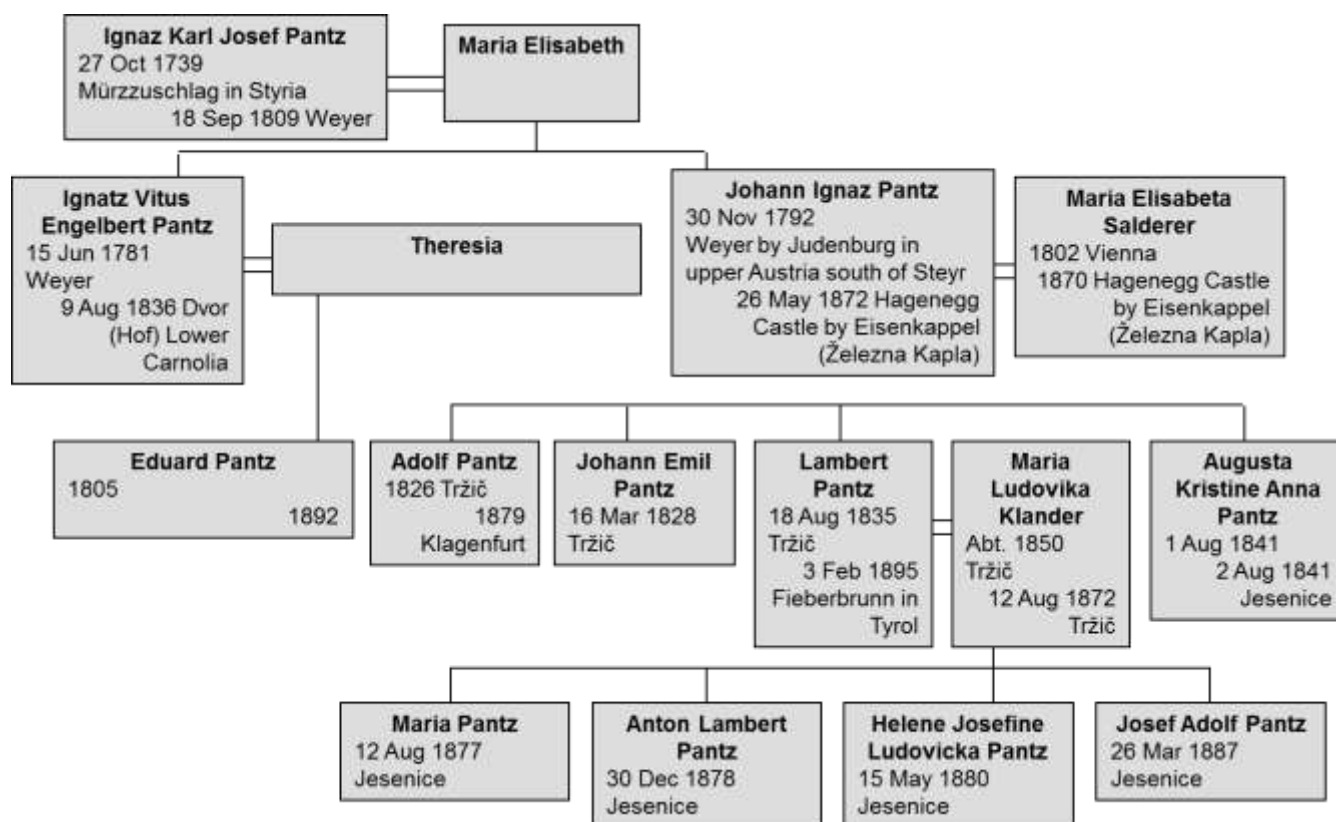

Figure 30-67: Family of Upper Carniola inventor Lambert Pantz

not have been synthesized in a way that they did it if they were aware of Israelis' anticipation. The Ljubljana nanotubes were significantly larger than Tenne's, as they had up to 20 μm diameter and were several mm long.

Dr. Maja Remškar just started her post-doctoral research at the Federal Polytechnic in Lausanne. There she had excellent electron microscopy facilities in the spirit of the microscopic tradition of Hacquet's contemporary Reynier. The professor

Francis Levy enabled her to continue researching inorganic nanotubes. Levy was not only aware of the great possibilities of a new discovery, but he also knew how to stimulate a young researchers by constantly supporting them. The Swiss academic circles have always been extremely hospitable to Slavic scientists like Einstein's first wife. Every year since then, Maja has been able to afford some carefully planned weeks of research in Lausanne, where on first-class devices, they examine their domestically developed ideas and check them in cooperation with their Swiss counterparts.

The Ljubljana process offered a more complete crystal structure than Israelis' achievements with a better understanding of the structural properties of new nanomaterials. In May 2001 she received the Zois Prize for her contribution to new nanotubes published in Science magazine. She wrote the only Slovenian contribution in the prestigious encyclopaedia of nanoscience and nanotechnology, published by the international publishing house Marcel Dekker, Inc. Slovenia has been recognized on the world map of the achievements of modern nanotechnologies.

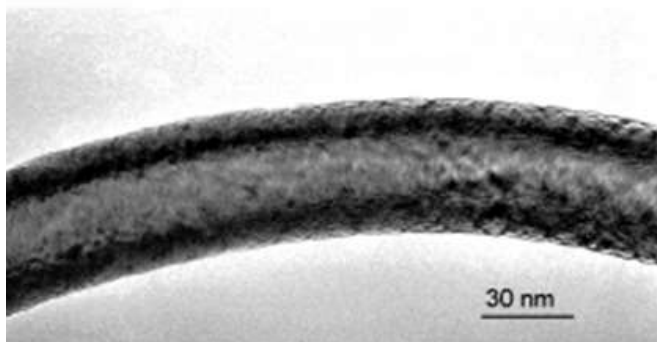

Figure 30-68: High-voltage cracking errors and peeling of the thin layer of the nanotube surface due to additional pressure upon bending (photo: Maja Remškar).

MoS₂ and WS₂ nanotubes were synthesized by Maja and colleagues in a conventional chemical transport reaction as commonly used for the growth of dihalogen layered crystals. They added the precious metals to sulfur, molybdenum or tungsten in a ratio of 0.5 % for the synthesis of the starting material before the beginning of the transport reaction. The reaction run for twenty-two days at a temperature of 1060 K in the emptied silicon vessel exhausted to a vacuum of a hundred Pa. The temperature gradient of 5.6 K / cm in a well-isolated ampoule was relatively small and

probably didn't detectably affect the growth of nanotubes.

The inorganic tubes do not withstand high pressures, but with the interlocking of their fibers they strongly resist the forces of stretching. The pipes have an extremely high surface-to-weight ratio, as well as the ratio of volume and weight. Both promise a useful use in the industry. Unfortunately, we are not yet able to measure the two relations exactly: they are in fact non-standard in themselves, but the problem of measurement is further complicated by the extremely small dimensions of the samples. We need to deal with individual molecules, but the direct measurements of the properties of the molecule are not so far anymore as the fulfilment of dreams of the previous centuries.



Figure 30-69: The first inorganic nanotubes in Ljubljana: a pair of WS₂ nanotubes grow from the inside of the micro-tube. A narrow tube with a diameter of 18 nm is wound sufficiently evenly around a thicker tube of diameter 40 nm. The mating of both tubes can be explained by the formation of intermediate surfaces between the crystalline nets of the two tubes. Contact between pipes is possible only at points where the arrangement and orientation of the walls are in accordance with the P63 / mmc spatial group (photo: Maja Remškar).

MoS₂ seems to be more promising than the similar WS₂ for Ljubljana researchers. The distance between the centers of approximately equally thick MoS₂ tube is 0.96 nm and is thus comparable to the smallest carbon nanotubes. The nanotubes grow in bundles with typical diameters of half micrometers, and in the length of several dozen micrometers under the influence of the C₆₀ catalyst. Catalysis is a complicated phenomenon in

these tight conditions, and we do not yet have the right model for it. Naturally, the choices increase, since nowadays we know many inorganic substances that form nanotubes.

Reshef Tenne (* 1944 kibbutz Usha in the western Galilee) was born in Israel, precisely during the final defeat of the Holocaust practitioners. After the tragic apartheid occupation of crusaded Palestine in June 1967 he received a diploma (1969), a master's degree and a doctorate at the Jewish University in Jerusalem combining physics and chemistry studies. After three years of study in Switzerland, he was employed at the Weizmann Institute in Rehovot, Israel, where he became a full professor in 1995. In the summer of 1991, he attended Tokyo University and there he listened to a lecture of five-year-old Iijima on the new discovery of carbon nanotubes. Reshef immediately observed the specialty of carbon, which behaved similarly in nanotubes or nanoparticles. Upon returning home, he consulted with colleagues and after a few months already reported on the first successes with inorganic nanotubes. Initially he by no means thought of sales and industrial uses of his inventions in the Japanese way, because he was especially impressed in the extraordinary properties of nanotubes whose properties already perceptibly aligned with smallest changes in diameter and screw resistance of the tubes. Their property is comparable with other popular materials today, for example with changes of colours of liquid crystals with the smallest increase in temperature, or with changes in crystalline structures and commercially available materials at phase transitions stretched to a wide temperature range. Soon Rashef discovered the benefits of his inorganic tubes compared to Iijima's use of them in higher temperatures, pressures and loads. Nevertheless, today carbon nanotubes still have great advantages on the market: first come first served.)

The growth of Ljubljana nanotubes resembles Hacquet's hard rime flowers; only the distances are thousand times smaller. Instead of Hacquet's microscope, Maja Remškar, of course, had to use a high-resolution transmission microscope. MoS₂ nanotube walls are built from a single layer of

MoS₂.³⁴²⁸ Thus, the first single nanoparticle of the inorganic compound was formed in Ljubljana and with it the first molecular crystal was made from nanotubes.

The sum of the flexibility energy per individual primitive cell of the crystal is higher in nanotubes than in larger micro-cells, where the elastic energy is distributed over a larger number of molecules. The accumulation of a layer of molecules in nanotubes of diameter down to 200 nm is different from that of ten and more thicker tubes. While micro-cells grow individually, nanotubes often form ropes and several dozens of them grow together up to a few millimeters in length. In nanotubes, individual specimen fuse while the forest of the tube grows with individual tubes-trees separated by very small angles. The instability of the growth of thin films of MoS₂ molecules in flat-shaped crystals under normal conditions for nanotubes, at the same time, allows for growth in extremely long hollow structures, which would surely delight even the old Hacquet. Of course, Hacquet could not distinguish nanotubes through his microscope.

Adding gold or silver to the mixture prevents chirality, which is otherwise shown by nanotubes from pure MoS₂. The walls of the tube consist of coaxial cylinders. Precious metals do not bind to the apertures of nanotubes where there is no room for atoms of precious metal, since the distance between the layers of the MoS₂ molecules is reduced due to greater internal pressure. The growth of the layer from a layer of molecules prevails. The precious metals are unevenly distributed in layers because they are practically absent at the nanoparticles.

Of course, Maja's discoveries are less prominent than Israelis' achievements, which have much higher financial support. Nevertheless, more and more modern researchers are researching the mechanical, physical and catalytic characteristics of inorganic MoS₂ tubes. At the Jožef Stefan Institute, nanotubes are still studied by dr. Dragan Mihailović.

The Israelis have already published the first theoretical calculations with powerful computers; experimental work has indicated new dimensions

³⁴²⁸ Panjan, 2001, 15; Remškar et al, 2001.

with helpful guidance.³⁴²⁹ Apparently, in inorganic nanostructures the growth of new compounds is stable only in cylindrical geometry. The concept of the crystal developed in Hacquet's age is changing rapidly today as we study new symmetries of the quasicrystals, viruses and nanotubes that Hacquet's contemporaries did not expect. Indeed, the description of the regular shapes of the crystals was already initially somewhat forced, as liquid crystals and other forms were discovered in parallel, while they were never consistent with the systematic classification of "ordinary" crystals. Nonetheless, the description of the ideal Schulz's and his contemporaries' crystalline network has been retained until today, when it is obviously that we need a change. It seems that there are no ideal correct structures in nature, just as they are not in relationships between people. The recent official change describes the crystals mainly in relation to their behavior under X-rays.³⁴³⁰ The regular shapes of rigid systems of previous centuries changed in modern world where even the gender and race ceased to obey its onetime dualities.

The new influence of geometry on the concept of stability in chemistry reminiscent of the reversal that explorations of geometric symmetries ~~which~~ had sparked in the physics of high speeds and great distances during Einstein's "wonderful" year. Among the important properties of the chemical compound, modern transient microscopes gradually include a geometric symmetry, which was not imagined during the former underperforming resolution. The more powerful devices opened up new dimensions of knowledge, resembling the happening in the more notorious, more expensive and ever-more powerful particle accelerators.

The nanoscience is already a well-established concept, but not inorganic nanotubes as its part. This will flower after the researchers of inorganic nanotubes will publish their own focused conferences, the specialized experimental tools, and monograph. Three fertile decades after the discovery, the time is ripe for the good textbook, as it will help the newcomers at the first steps in a promising new scientific field.

30.2.7.7 Conclusion

Inventions in science are the result of sudden surprise called discovery. However, there is no discovery without a solid prior work. The fertile research is always based on the shoulders of many scientists, who substantiate and facilitate the invention with their contributions for centuries. Due to the lack of money and the excess of local traditional quarrels, the large discoveries in small Slovenia are rare. The nanotubes are not large by themselves; therefore, they may be right goal for researchers from small Slovenia.

³⁴²⁹ Seifert, Köhler, Tenne, 2002, 2497.

³⁴³⁰ That note used by the courtesy of dr. Janez Dolinšek.

31 Industrial Uses of Vacuum Technologies - Luminescence

31.1 History of Research of Luminescent Materials

The research of luminescence might not belong to the proper vacuum technologies, but both have their strong correlations. "Phosphorus is called the body whose light is like the light of the moon and is often even weaker. They do not leave a stronger impression in the eye in which they collect, nor they cause sensible heat, nor they significantly increase the temperature of the surrounding bodies." Thus, luminophores and the phosphorus elements, which he commonly referred to as phosphorus, were described by a long-time professor of physics in Ljubljana Ambshell two hundred years ago.³⁴³¹ Today, we describe luminescence with the difference between its high energy absorbed and the lower energy of the photons emitted. The distinction between definitions is the product of centuries of research, discoveries, and errors that have enabled many uses of luminophores, without which one cannot imagine the modern lights, computer and television world of Ching Wan Tang's organic light-emitting diodes (OLED) developed for Eastman Kodak.

31.2 Research of Luminescence before the Discovery of Ultraviolet Lights

As in most other history of knowhow, the westerners learned most about the luminescence from Africans, Asians, Oceanians and Native Americans to appropriate their wisdom into European business. We will learn a lot about Westerners' success while the real colourful inventors must be described later. The shine of matter in the dark has attracted attention already in Antiquity. The indigenous peoples of Indonesia used bioluminescent fungi as flashlights in their forests. The Daoist Record of the Ten Sea Islands (Ten Continents in World Ocean, Ten islands in

the inner seas, Hai Nei Shih Chou Chi, 十州記, Hainei shizhou ji, 海內十洲記) in a fourth or fifth-century BCE China detailed nautical adventures including fiery sparks when the water is stirred, later attributed to the Han court jester Dongfang Shuo (東方朔, c. 160 BCE – c. 93 BCE). The bioluminescence of mushrooms and fish was already known to Aristotle, and Pliny the elder also described the phosphorescence of rocks.³⁴³² All the way to Osamu Shimomura's (1928, Kyoto-2018, Nagasaki) Nobel Prize in Chemistry 2008 for his research of the maritime jellyfish *Aequorea victoria* Green Fluorescent Protein (GFP) inspired by the Japanese WW2 experiences including his teenaged spotting of Bohr's bombing of his native Nagasaki. The bioluminescence was and still is far-eastern domain despite of Princeton university and Eastman Kodak involvements.

31.2.1 First European Description of Fluorescence

The Native Americans might have influenced early modern European luminescence even more than Far Easterners. The ancient Maya polished jadeite appears luminescent and glassy. Their *Eysenhardtia polystachya* (blue wood (Palo azul), *Mexican kidneywood*) was always widely used in folk medicine as an anti-rheumatic, analgesic medication, blood depurative, antitussive, antispasmodic, anti-diabetic, febrifuge, anti-inflammatory, herbal remedy for several illnesses on the renal tract, especially as a diuretic and antimicrobial agent for treatment of kidney and bladder infections. In 1565 the Spanish physician Monardes first told Europeans about fluorescence of that small Mexican tree *Eysenhardtia polystachya* which Aztecs cooked for the beneficial effects of tea prepared from its wood. The "lignum nephriticum" was derived from its water solutions known in various forms in ancient India tall tree narra (*Pterocarpus indicus*) while it was particularly common in Mexico nicknamed "New Spain". The other "lapis nephriticum (λίθος νεφριτικός; νεφρός λίθος)" which means 'kidney stone', is nephrite $\text{Ca}_2(\text{Mg}, \text{Fe})_5\text{Si}_8\text{O}_{22}(\text{OH})_2$ as one of two different mineral species called jade. For one reason or another, the

³⁴³¹ Ambshell, 1792, 4: 279, 280; Ambshell, 1807, *Dissertatio secunda de lumine*, 133.

³⁴³² Emil Wilde (1793-1859), professor of mathematics and physics in Berlin Grammar school, *Geschichte der Optik vom Ursprunge dieser Wissenschaft bis auf die gegenwärtige Zeit*, Rucker & Püchler, Berlin 1843, II part, 384-385.

water solutions of the wood and the mineral are both believed to be a cure for the troubles with kidneys stones in folk medicine, probably because of the remote awareness of the equally luminescent phosphorus contained in urine. In the same book, Monardes also published the first description of the tobacco that the Native Americans showed to Spaniards.³⁴³³

The Ljubljana copy of posthumous Dutch edition of Monardes' book was bind to his other medical work printed in the year 1582 and to five works of other contemporaries. In 1626, the book was owned by the Viennese doctor of Conrad Widder, probably related to Widdeke or Widdersheim. Later, the book was moved to Ljubljana Augustinians' library and after Josef II suppressed the Augustinians in Ljubljana it was catalogued in the Lyceum library in Ljubljana around 1800. Certainly, the folks of Ljubljana were cured from their kidney stones by Augustinian readers of Monardes' book in no time.

Monardes' data were soon supplemented by his fellow Mesoamerican intruders. Bernardino de Sahagún (born Bernardino de Rivera (Ribera, Ribeira), c. 1499 Sahagún-1590) as a Salamanca educated Franciscan friar learned Aztec Nahuatl language to research their plants and habits for his bilingual Spanish-Nahuatl manuscript General History of the Things of New Spain (Historia General de las Cosas de Nueva España) best preserved in its Florentine Codex. Next the university of Alcalá graduate Francisco Hernandez (1514 La Puebla de Montalbán, Toledo-1587 Madrid) worked closely with Aztec artists and physicians in central Mexico for his *Nova plantarum et mineralium mexicanorum historia* partly published by Galileo and his patron Cesi. All was prepared for Bologna stone as the first among early modern imported European optical curiosities predeceasing the Bolognese Jesuitical diffractions and Danish birefringence.

31.2.2 *The First European Artificial Luminophore: "Bologna Stone"*

The dissolved natural stones and wood luminophores made their European front pages only after their local alchemists were able to copy their effects, the same as happened after the

discovery of radioactivity three centuries later. The shoemaker with alchemistic ambition Vincenzo Cascariolo (Casciriolo, Casciarolo, 1571 Bologna-1624 Bologna) obtained the first European artificial luminophore by his alchemical experiments in Bologna between 1602 and 1604. He mixed his grounded barite BaSO₄ dug up by Monte Paderno above Bologna and powdered charcoal. At night he noticed that the cooled mixture emits purple-blue light.

Galileo was among the first to learn about the novelty at the nearby University of Padua. Upon his demonstration of telescope to the Pope and Roman erudite, Galileo gave the piece of stone to his peripatetic friend Lagalla in 1611. The shine of the "Bologna stone", also called "lapis solaris", put at the limelight the doctor Giulio Cesare Lagalla (La Galla, 1571 Padula by Salerno-1624 Rome) from the Roman College later called Sapienza, who first published the discovery. In retention of light in luminophore, Lagalla saw the proof that light does not have weight, since the weight of the stone does not change during luminescence. He thus opposed the claims of Galileo and criticized Galileo's description of the lunar observation through the telescope in the same booklet.³⁴³⁴ Galileo was angry, but he did not publicly respond.

Lagalla (1612), Fortunio Liceti (1640), Kircher (1641), Schott (1656), as well as the 18th-century researchers Dufay (1735), Scheele (1771) and Herbert (1773) assumed that luminophore absorbs light as a sponge. The curator of Aldrovandi's collections the Bolognese mathematician-astrologer-physician Ovidio Montalbani (1601 Bologna-1671 Bologna) from the illustrious Bolognese family in 1634, Leméry (1698), de Mairan (1717), the changeable Dufay again in 1726, Zanotti (1748), Volta (1776) and de Saussure (1792) assumed that it was a type of burning.³⁴³⁵

Montalbani's elder colleague professor of Philosophy at the University of Bologna Fortunio Liceti (1577 Rapallo-1657 Padua) described the "pietra lucifera di Bologna (*Litheosphorus, sive De lapide Bononiensi lucem in se conceptam*)" in 1640. He believed that unilluminated side of the

³⁴³⁴ Mladenović, 1985, 177.

³⁴³⁵ Edmund Newton Harvey, A history of luminescence. From the Earliest Times Until 1900, The American Philosophical Society, Philadelphia 1957, 362.

³⁴³³ Monardes, De simplicibus medicamentis 1574, 50-52, 21.

moon shined with brighter light due to phosphorescence, like the "Bologna stone". Therefore he criticized the correct Galilean description of lunar ash light, the reflection of the sunlight from Earth, published already by Leonardo da Vinci (1452-1519). Liceti was one of the most important thinkers of his time. Among other things, he also wrote to Gassendi about the atoms. That is why Galileo could not overlook his criticism, as he initially intended. In the spring of 1640, a former Galileo's pupil Prince Leopoldo Medici (1617-1675) wrote from Florence to Arcetri to persuade Galileo to answer "Liceti's light-hearted arguments". In his last scientific work produced before his death Galileo criticized Liceti in "Lettera al Principe Leopoldo di Toscana". He labeled Liceti's great knowledge as a mere gathering of unrelated facts, and he rejected the analogy between the Moon and the "Bologna stone" as unfounded. Certainly, Galileo and Liceti befriended already during their joint teaching in Padua, therefore Galileo's criticism was relatively friendly. Later, on 19 June 1657, the prince Leopoldo chaired the first European experimental physics group called Academia del Cimento.³⁴³⁶ Liceti's idea of the phosphorescence of unexposed celestial bodies was used by Puluj in his description of Venus centuries later.³⁴³⁷

Lagalla, Montalbani, Paduan and Bologna professor Liceti were not the Jesuits. Finally, the Roman Jesuits joined the luminescent Bolognese debate which was reserved for alchemists and physicians up to date. Kircher completed his description of "Bologna stone" six years after Liceti with his own observations of luminescence of animals, fish and stones. He noticed that "the light emanating from the stone is not constant, because it faded with time like a magnet. The power of the simplest shining "fireplaces" is suppressed by the elimination... The light is within the shadow, and it is stored in the shiny body. In contrast to the prevailing opinion of the educated philosophers, (Bologna) stone drags light on itself like oil attracts fire and magnet attracts iron. Light in such a stone has the properties of heaven and fire to shine in darkness, like the Moon itself. In some stones light ignite the atomic particles which are trying to get rid of that light in one way or another."³⁴³⁸

³⁴³⁶ Kuznecov, 1964, 134, 274-276.

³⁴³⁷ Puluj, 1889, 308.

³⁴³⁸ Kircher, 1646. 27.



Figure 31-1: Figure: Kircher's page of Ars Magna with description of Liceti's work.

Kircher's work had a profound influence on contemporaries, especially in Jesuitical schools. In the Jesuit college in Ljubljana it was obtained already in 1697 as a gift of the prince Auersperg. During the fire on 28 June 1774, it was borrowed, since it was not listed among the books that were saved from burning on March 1, 1775. Galileo criticized and ridiculed Kircher's approach to science in his letter to Torricelli. Kircher used to mix astronomical records of music or astrolabe clock with medicine against the bite of the tarantula related to the dance tarantella at the same page of his book. The Aristotelian Kircher was widely read as a great Jesuitical information mailbox but officially mocked as the modernized European sciences preferred focusing on single simplified topics. Galilean, Boyle's, and Huygens's criticism alienated later scientists from Kircher's physical investigations,³⁴³⁹ until modern revival of studies of Kircher in the USA.

Kircher is often referred as the discoverer of fluorescence in solutions, as he wrote that the solution "is transparent in the light, and in the shadow the dark parts become reddish and

³⁴³⁹ Kuznecov, 1964, 276, 278.

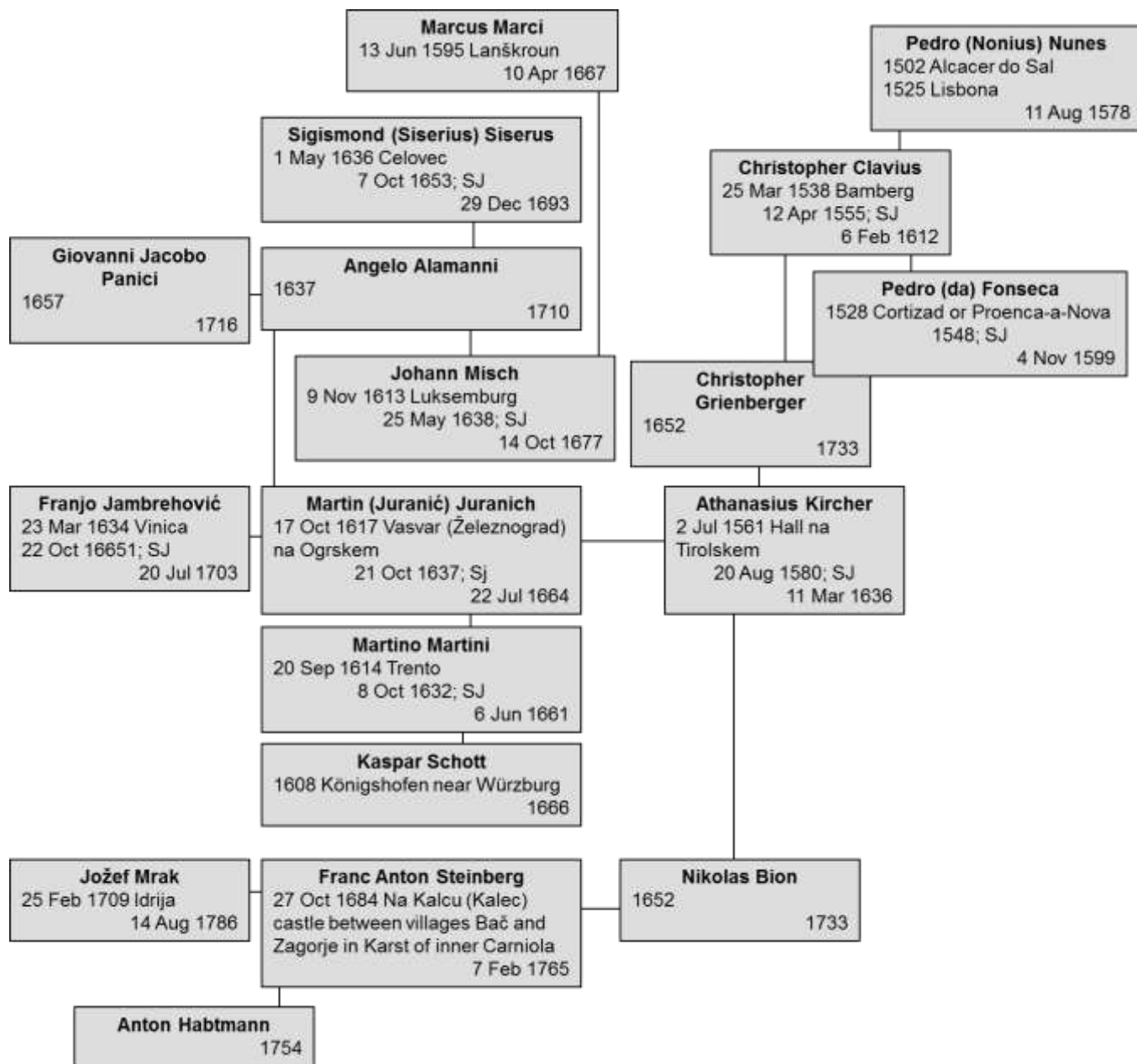

Figure 31-2: Academic ancestors and descendants of Athanasius Kircher

magically change according to the color of the environment ... To the best of my knowledge, I am the first to notice this chameleonic property of (luminophore)". The local procurator of society of Jesuits Francisco de Florencia (1619/20 Florida Espanola-1695 Mexico) sent the "Lignum nephriticum" solution to Kircher by a vessel sailing from Mexico so that Kircher and his fellow Jesuits could show the phenomena to the rulers. Newton and others later corrected Kircher's description.³⁴⁴⁰ The clever Jesuits cashed their ability to perform

³⁴⁴⁰ Harvey, 1957, 392-393; Boyle, *Opera varia* Genevae 1680, 81.

missionary and scientific works in the areas unreachable to the other European mortals of those times.

31.2.3 Chemical Element Detection: Phosphorus

The Italian monopoly of European luminescent debates was over when the different German alchemistic approach entered the stages especially in Saxony desperately ruined during the Thirty Years War. The junior army officer of Thirty Years War turned unsuccessful Hamburg dealer Hennig Brandt (also Brand, around 1630 Hamburg-1710 Hamburg) extracted phosphorus

from several tons of urine obtained from the Hanoverian military barracks between the years 1669 and 1675. For 200 thalers he disclosed the discovery to his friend, the doctor of medicine and court councilor of Prince elector of Mainz and Saxony, Johann Daniel Krafft (Kraft, Crafft, 1624 Werheim-1697 Amsterdam). In the same year, Leibniz's friend-collaborator Krafft informed Boyle of the discovery after the ceremony when Newton was named professor of physics at Cambridge. The other Leibniz's friend Papin was also there assisting Boyle in the same era more as an engineer and not so much as the alchemist. According to other sources, Boyle discovered the item himself by Krafft's directions. On 17 May 1677, the Lutheran Krafft gave a lecture on phosphorus at the Royal Society in London. Boyle was in the audience and Boyle soon announced that "the cold light of the Bologna stone" needs air while it is quenched by ammonia and alcohol, among other things. He also studied the flickering of animals and "lignum nephriticum". The company of the former Boyle's assistant of German genus Ambros Godfrey Hanckwitz (1660 Köthen (Cöthen, Anhalt)-1741 London) successfully produced and sold phosphorus in England and elsewhere in Europe during half of a century. Hanckwitz skillfully advertised his products, became rich and even the baron, while his descendants were less lucky.

The son of alchemist at the court of Holstein prince Kunckel rediscovered the phosphorus at a time when he was a lecturer at the University of Wittenberg in 1676. Other sources report that he learned secrets from Krafft, or from Brandt. Kunckel also became famous with his ruby glass.³⁴⁴¹

In the spring of 1677, Krafft organized a public presentation of phosphorus at the court of Johann Friedrich (1625-1679) in Hanover, where Leibniz also listened as newly appointed ducal privy councillor and librarian. In 1710, with his authority, Leibniz helped recognition of Brandt's discovery of phosphorus in Saxony.



Figure 31-4: The title page of Kunckel's notes about chemistry published in 1721 with his phosphorus described in fourth part of the copy of Idrija pharmacist E. Freyer, today kept in NUK.

Leibniz closely followed the whereabouts of the economist-alchemist Johann Joahim Becher. Becher studied the properties of phosphorus as a chemistry professor at the University of Mainz together with his friend the doctor of electoral prince in Mainz Georg Caspar Kirchmaier (1635-1700 Wittenberg), who also reported on Kunckel's

³⁴⁴¹ Under Kunckel's portrait on the cover of his book on experimental chemistry from 1738 there is a propriety entry of Ernest (Ernst) Freyer, born in Žatec of Bohemia, a pharmacist in Idrija. His knowledge of the botany was also appreciated by Janez Anton Scopoli (1723-1788), who was a medical doctor in Idrija between 1754 and 1770. The botanist Henrik Freyer (1802-1866), Ernest's grandson, was the curator of the Regional Museum in Ljubljana between 1832 and 1853. E. Freyer's signature shows that Kuckel's discussions on chemistry from 1721 with the description of phosphorus in part IV was also once his property

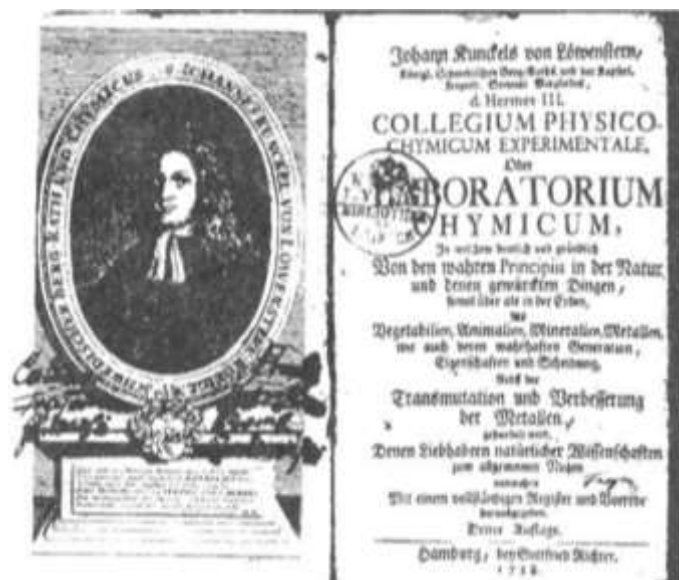

Figure 31-3: Figure: Kunckel portrayed by the title page of his book with the signature of previous owner the Idrija pharmacist E. Freyer in a copy today kept in NUK.

research. As the professor of Wittenberg university Kirchmaier also published his student's university exam disputation *De vacuo et loco, pro loco* to claim that the total vacuum is not possible in 1660. On twenty-two pages he noted Hero, Bacon de Verulam, Democritus, Jan Baptist van Helmont, Valeriano Magni, Guericke from Magdeburg 50 km west of Wittenberg, G. Schott in Würzburg 300 km northwest from Wittenberg, Cartesians, the Jesuit Arriaga, Sennert and many others except Torricelli and Boyle. Kirchmaier probably retained some peripatetic doubts about vacuum.

Lemery reported how the Saxon official Christian Adolph Balduin (* 1632 Döbeln southwest of Leipzig; † 1682 Grossenhain west of Leipzig) treated luminescence during his search for the alchemistic philosopher stone. At first Balduin kept his production secret, but the clever Johannes Kunckel coaxed it from him and made a profit from the public demonstration, as he did a little later with the phosphorus designed by Hennig Brand. In 1675, Balduin discovered that the residue of the distillation of the crushed chalk solution in saltpeter (nitric) acid is lit in a dark like "Bologna stone". The shimmering flickering rapidly waned outdoors, and much longer lasted in a hermetically sealed glass tube. Balduin lived for a while in Regensburg and as the member of Academy of Sciences Leopoldina had a lot of opportunity to learn all about sealing techniques of his quarter of century older fellow Saxon official Guericke. Balduin described his method of production in a difficult hardly understandable alchemical language. His second artificial luminophore CaNO_3 , probably with some sulfur added, was sent to the Royal Society of London with a cover letter in 1676. The preparation of Balduin's "phosphorus hermeticus" was improved by Placidus Heinrich.³⁴⁴² Later studies have shown that phosphorus surrounded by air is shining due to slow oxidation of vapor without photoluminescence involved. Similar chemiluminescence as in phosphorus is furthermore observed in many other substances, and the phenomenon is also the foundation of all bioluminescence.³⁴⁴³

Friedrich Hoffmann (1660-1742), professor of medicine in Halle, discovered the luminescence of the gypsum CaSO_4 in 1700, but did not describe

his preparation process in more detail. In the meanwhile, the Chinese, Mesoamerican, North Italian, Roman, Saxonian and imperial Prague alchemistic research of (artificial) luminescence entered Boyle's and Newton's England. The weaver's son John Canton (1718-1772 London) as the assistant teacher at a private school in London calcinated oyster-shell (as calcium carbonate) with sulfur to get impure CaS in 1768. That yellow light luminophore is still called by Canton's name. A similar substance was already known to the Chinese³⁴⁴⁴ as described in the vinaya (jièlù 戒律, kairitsu 戒律) related text of master Buddhist monk chemist-microbiologist Lu Tsan-ning's (919-1001 AD) *Sung Biographies of Eminent Monks* (*Sung Kao-seng chuan*) finished in 988. The Chinese gradually influenced all European research including Barbara of Celje. The joyful fans of Roman mysteries of Bacchus widely used J. Canton's luminescent compound of lime and sulfur in 300 BC.

Soon the luminescent phosphorus got its rivals while Liebig's chemistry developed into profitable discipline. After his return from Moscow economical institute to Frankfurt on Oder and Berlin, the opponent of vital force theories of chemicals like phosphorus or potassium Johann Friedrich John (* 1782 Anklam; † 1847 Berlin) noticed phosphorescence of strontium sulfide in his textbook published in 1817.

31.2.4 *Investigation of Luminescence after the Discovery of Phosphorus*

The luminescence was researched in parallel with other optical phenomena. Nevertheless, because of its alchemistic background it did not affect the development of optics so much as the diffraction or the double refraction (birefringence), first described by the professor Erasmus Bartholin (1625-1698) in 1669 in Copenhagen. In the same year his elder brother Thomas (1616-1680), professor of anatomy in Copenhagen, published the 2nd edition of his bioluminescence research of the animals first issued in 1647.

The electroluminescence has prompted a lot of attention in the pioneering era of electrostatics. In 1768, the weaver's son Canton investigated the

³⁴⁴² Wilde, 1843, 390.

³⁴⁴³ Harvey, 1957, 448-.

³⁴⁴⁴ Teple, 1991, 171.

excitation of luminescence by discharging³⁴⁴⁵ resembling a century later research of another textile businessman's son Crookes. The prior in Rillé and Anjon, the member of AR Abbé Jean Picard (1620-1682) studied electroluminescence in an empty glass vessel in 1675. His device was called the "electric egg". He also described the triboluminescence of mercury in a barometer,³⁴⁴⁶ which was additionally examined by Hauksbee in 1709 and influenced Newtonian experiments with colours. The research was continued by Swiss Johann Bernoulli (1667-1748) and his son Daniel Bernoulli, until the Berliner physician and academic Christian Friedrich Ludolf (1707-1763) preferred the explanations with electric charges as his barometer first attracted and later repelled the nearby paper in 1744/45. The era of luminous phenomena of electrical discharges in rarefied gases was born to broadly affect next three centuries, literally born out of nothing.

The European part of our story began in Bologna. The first artificial luminophore earned the name "Bologna" both by the inventor and by researchers who published their findings in the Bolognese Academic Bulletin in 1731. The Bolognese Jesuitical student Domenico Gusmano Galeazzi (Galeati, 1686 Bologna-1775 Bologna) learned his science under the influence of professor of physics at Bologna Giacomo (Jacopo) Bartolomeo Beccari who published his research of phosphorus in 1768 to influence his Ljubljana fans. On 11 April 1771 Beccari's letter about his phosphor sent to J. Canton was read at the Royal Society of London. In 1714 Galeazzi met Louis Lémery, Malebranche and Réaumur in Paris. In 1716 Galeazzi was appointed professor of philosophy at Bologna and kept that post for forty years. He began as substitute lecturer in experimental physics; in 1734, when Beccari transferred to the chair of chemistry, Galeazzi succeeded him as professor of physics. In 1731, his first published work in physics dealt with the construction of mercury thermometers as he found that phosphorescence is weakened in vacuum, but its duration does not change. Galeazzi further published in his Bolognese *Commentarii de Bononiensi Scientiarum et Artium Instituto* about the thermometers of Amontons' drafting ("De thermometris Amontonianis conficiendis) in 1746.

Galeazzi's boss, the professor of Logic, Philosophy and Physics at the University and President of the Academy of Bologna Francesco Maria Zanotti (1692-1777) described the characteristics of the "Bologna stone" in 1718. He endorsed the wave hypothesis because the stone always illuminated in its characteristic color, regardless of the color of the illumination.

Galeazzi and his role model Giacomo Bartholomeo Beccari (Jacopo, 1682 Bologna-1766 Bologna) used to be Jesuitical students. Beccari also published with the Bolognese Academy. In 1758 he corresponded with his 34-years younger Piarist Giovanni Battista Beccaria, Bošković's friend and supporter of Franklin's theory of electricity.³⁴⁴⁷ Jacopo Bartholomeo Beccari distinguished natural and artificial "phosphorus" and among them noted the luminophores as well as elementary phosphorus, just like Ambshell later. Beccari described the colors of various luminophores and found that there were no metals among them, but they included the many useful types of salt.³⁴⁴⁸ In

³⁴⁴⁷ Dell'elettricismo. Lettere di Giambattista Beccaria De CC. RR delle Scuole Pie, Professore di Fisica Sperimentale nella Regia Università di Torino, Membro della Società Reale di Londra, e dell'Accademia delle Scienze di Bologna ec.ec. dirette al Chiarissimo Sig. Giacomo Bartolomeo Beccari Preside perpetuo, e Professore di Chimica nell'Istituto di Bologna, membro della Società Reale di Londra, e dell'Accademia delle Scienze di Bologna ec.ec. coll'Appendice di un nuovo Fosforo descritto all'illmo (= illustrissimo) Sig. Conte Ponte di Scarnafigi. Alla Sacra Reale Maestà del Re di Sardegna Colle Ameno in Bologna all'insegna dell'iride con lic.de'sup.an. 1758. The Piarist Giovanni Battista Beccaria (Beccaria, 1716-1781), professor of rhetoric and philosophy in Rome and Palermo, taught experimental physics at the University of Turin since 1748. He wrote a letter to Jesuits' student Iacopo (Giacomo Bartholomeo) Beccaria (Beccari, 1682-1766), doctor and professor of chemistry at the Institute of Sciences in Bologna (*Accademia delle Scienze dell'Istituto di Bologna*), also a fellow of the RS and of the Bologna Academy of Sciences, who was Galvani's teacher. The book is kept in the library of the Italian gymnasium in Koper with the bookplate of the local Piarists. Considering the later controversy between Galvani and Volta, it is interesting that Piarists were teachers of them both

³⁴⁴⁸ Reprint: Viri Clarissimi Iacobi Beccariae Comentariorum duo, de Phosphoris Naturalibus et Artificialibus, ex Actis Bononiensibus Excerpti, Graecii, Typis Haeredum Widmanstadii, Anno Domini 1768, 12, 19. His work was republished by the Jesuits G. Schöttl in Ljubljana and by Gottlieb Leopold Biwald (1731-1805), an influential advocate of Bošković's theory, who in the sixties also lectured on the Ljubljana lyceum. In 1798 the book was enumerated in the library of Jožef Klasanc Erberg (1771-1843) in Dol, and until 1803, Wilde enrolled it in the Lyceum

³⁴⁴⁵ Wilde, 1843, 392.

³⁴⁴⁶ Wilde, 1843, 392, 406; Bowers, 1998, 112.

contrast to Zanotti, Jacopo Bartholomeo Beccari, after an experiment of 1770, considered that the "Bologna stone" was shining blue under the blue kind of glass but shined red under red glass, while he later doubted the accuracy of his own measurements. In 1772, Priestley nevertheless cited him in support of Newtonian corpuscular theory of light, which greatly hurt Seebeck who preferred Goethe's waves.³⁴⁴⁹



Figure 31-5: Figure: The title page of Giacomo Bartholomeo Beccari's book about phosphorus reprinted by Biwald in Graz and by G. Schöttl student in Ljubljana, catalogued in Erberg's library on 1788, in Lyceum library of Ljubljana on 1803 and in Franciscan Ljubljana library.

library in Ljubljana under no. 1474, where it is still stored in NUK today.

³⁴⁴⁹ Johann Wolfgang von Goethe (1749-1832), Zur Farbenlehre, Tübingen 1810, 342, 709-710, 711-714 (In second part of the book *Geschichte der Farbenlehre* Thomas Johann Seebeck (1770-1831) as a member of the Academy of Berlin from 1818, published his research entitled *Wirkungen farbiger Beleuchtung* at pages 703-724); Wilde, 1843, 386; Keld Nielsen, Another kind of light: The work of T.J. Seebeck and his collaboration with Goethe, Part I, HSPS, 20 (1989) 145.

In 1746 the Swiss Leonhard Euler (1707-1783), a professor of mathematics at the University of Berlin, explained luminescence with fluctuations at luminophores' own body triggered by absorbed light. His wave theory was contradicted by Bošković, according to whom the particle of light should be absorbed in the body at the distance from the material point's centre of forces where the attraction prevails. Due to the internal heat motion, the same particle should be later radiated at a lower oscillation rate (frequency) at the distance from the centre of forces at which the repulsive force is predominant. Bošković explained the delay in phosphorescence like his other contemporaries: "After reflections along the many-sided and diverse paths within the opaque bodies, the light at least partially reaches the surface particles and then radiates. From this emerges the light of many accessible phosphorescence bodies, which is hidden from the sun in darkness and later shines for a few seconds. The number of seconds of its delay allows us to guess about the length of the path between its many movements, inside and outside the bodies..."³⁴⁵⁰

31.2.5 *Echoes of Luminescence Exploration in Ljubljana*

Among fifty-four experimental devices acquired for teaching physics and mathematics in Ljubljana was probably also a "Bologna stone", although the term "vitra Bononiensia" was used instead of the usual "lapis" on 17. 9. 1755. However, it might have also been a Bologna bottle (Bolognese phial, philosophical vial) of great external strength, often used in physics demonstrations and magic tricks, created by heating a glass bottle and then rapidly cooling the outside whilst slowly cooling the inside. This causes external compression and internal tension such that even a scratch on the inside could shatter the bottle as noted in the publication of the Royal Society in 1740s after its discovery in Bologna.

The short Napoleonic occupation stimulated additional fans of luminescence in Ljubljana. In Kersnik's census of 1811, we find both barite and phosphorus.³⁴⁵¹

³⁴⁵⁰ Rudžer Josip Bošković (1711-1787), Croatian Jesuit professor of Collegio Romano, *Theoria philosophiae naturalis*, Venetis 1763. Reprint: Zagreb 1974, 228 (Num.491). First printing in Vienna in 1758.

³⁴⁵¹ Kersnik, 1811.

The oldest published luminescence records in Ljubljana were included in Lyceum examination theses about the heat and light of professor of physics G. Schöttl in 1772. The theses were based on Newtonian science in Boerhaave's interpretations. At his 26th thesis Schöttl asked students about luminescence: "What is the difference between annealing, heat and light? What is pyrophore (substance that ignites spontaneously by contacting air)? What is phosphorus? What are the characteristics of artificial and natural phosphorus? Is the light of phosphorus the very light of the Sun hidden within the body of luminophore until it is excited by the sunshine, or does the absorbed light in luminophore lead to the movement of its radiated light?"³⁴⁵²

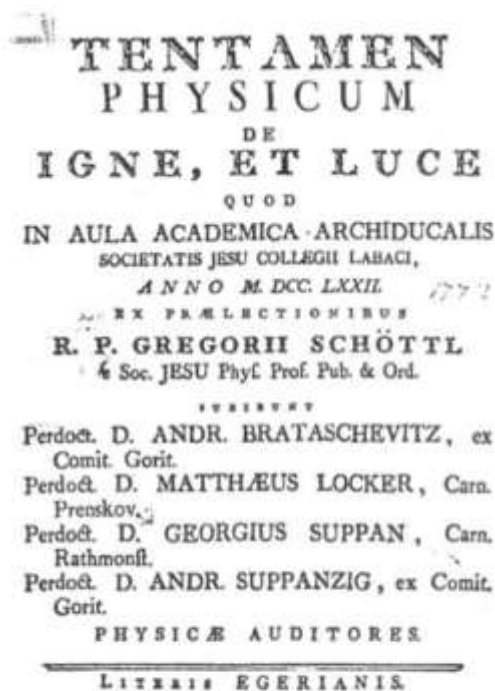

Figure 31-6: The title page and 26th exam theses about luminescence in G. Schöttl's class in Ljubljana on 1772.

After Schöttl passed away, the chair of physics on the Lyceum of Ljubljana was taken over by Ambshell as another important advocate of

³⁴⁵² Pyrophors are substances that spontaneously burns in the air, but usually with this word they meant a fireburst (Harvey, 1957, 448).

Bošković's physics.³⁴⁵³ In Ambshell's examination theses there are no questions about luminescence, but he described it in his textbooks of physics, which, after the dissolution of the Ljubljana lyceum, he published as a professor of physics and mechanics at the Viennese University.

Ambshell distinguished "phosphors" that only glow in contact with the air and others, "which do not need to contact any air, and emerge in an empty space, so that they have to get their light from the Sun, or they shine because of their elevated temperature. Bologna phosphorus is shining in the air and in an empty space..."³⁴⁵⁴

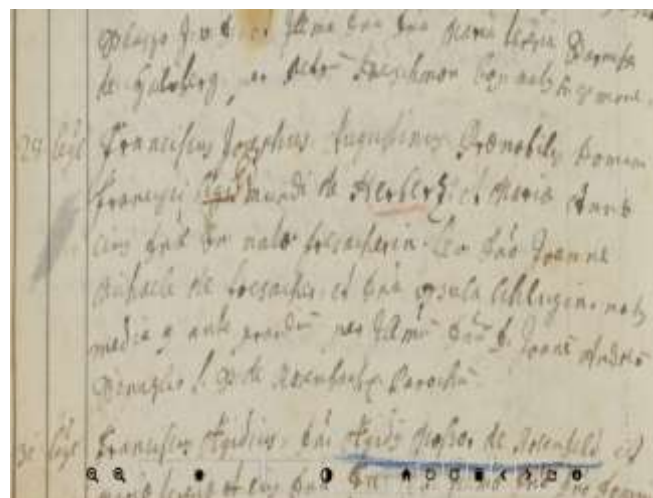

Figure 31-7: The birth certification of Joseph Herbert noted at St Egidius church in Klagenfurt on 28 August 1725

He observed the luminescence through the prism in a darkened room with an opening designed for illumination. He described short-term electroluminescence discharged in the air³⁴⁵⁵ and in a vacuum of barometric tube.³⁴⁵⁶ Concerning the phosphorescence of diamonds, "in subsequent experiments, it would be worthwhile to know more about the diamond components and about the forces that combine them."³⁴⁵⁷ In fact, already two decades earlier in 1772 Lavoisier concentrated the rays of the sun by lens on a diamond in an oxygen atmosphere to produce carbon dioxide as a proof that diamond is composed of carbon.

³⁴⁵³ Ambshell, 1807, Dissertatio prima, 62, fig.1.

³⁴⁵⁴ Ambshell, 1792, 284.

³⁴⁵⁵ Ambshell, 1792, 285.

³⁴⁵⁶ Ambshell, 1792, 290-292.

³⁴⁵⁷ Ambshell, 1792, 285, 290.

From 1771 to 1773, Ambshell studied physics and mathematics in Vienna with a professor of experimental physics and Canon of St. Stephen Carinthia native Jesuit Josef Edler von Herbert (Joseph Herverth, Hervert, Herwerth, Baptized in Klagenfurt St. Egid on 26 August 1725 Klagenfurt-18 March 1794 Linz or parish Wels-St. Stephan 20 km southwest of Linz in bishopric Linz), one of the most important researchers of luminescence. The physicist Joseph Herbert was a grandson of a grandson of Eduard Herbert, a member of the well-known Welsh-English family of the Herbert counts von Pembroke and Montgomery, who left his fatherland at the time of Cromwell's Protectorate. As a prosecuted British Catholic he was attached to the house of Stuart under Charles I. He first turned to France and from there because of the Huguenot unrest to German Münster, where his son Herrmann Herbert as a poor emigrant lived at Rūden in Westphalia 30 km north of Cologne. The wars raged under Louis XIV and the controversial bishop of Münster Bernhard von Ghellen (Gallen, Christoph Bernhard baron Galen, 1606 Drensteinfurt-1678) damaged the countries between the Rhine and the Weser. Herrmann's son Johann studied medicine in South Germany to gain his doctorate in pharmaceutical sciences Innsbruck. As doctor he became a protomedicus at Klagenfurt in Carinthia. On March 19, 1692 he married there the nice widow Rosina Barbara von Khleß, a sister of a provost of Teinach (Teinach, Tinje) 10 km east of Klagenfurt, who took care of Johann's offspring after the pest murdered Johann in Villach (Beljak). Soon after the completion of his philosophical studies Johann's son Franz Edmund was raised to the inherited knighthood by the emperor Karl VI on September 21, 1715. The physicist Joseph Herbert was a son of Franz Edmund von Herbert and grandson of the physician Johann Herbert who immigrated to Carinthia from Paderborn in eastern North Rhine-Westphalia 100 km southwest of Hanover in the direction of Bonn. The younger brother of physicist Joseph Herbert, (Johann) Michael visited Holland and England of his ancestors to study the production process of lead and gain deeper insights. In 1761 he used Dutch process to establish the first Austrian fabric of white lead (Bleiweiss) in Ehrental by Klagenfurt with exports all over Europe. Johann Michael Herbert heated the lead in iron cauldrons, scooped out in liquid form with pans and poured onto cold iron plates to form thin lead sheets. These were then cut into narrow

strips, rolled up and placed in glazed jugs filled with vinegar for fermentation, which in turn were placed in pits filled with manure. Herbert first used Styrian wine for the vinegar preparation, then a heavy wine from Veneto. Herbert was one of the founders of the Carinthian Agricultural Society on October 1, 1764, which progressed the local agriculture. In 1763 the entrepreneur from Klagenfurt, later employer of Jožef Stefan's parents, bought a paper mill in St. Veit an der Glan, because he needed blue wrapping paper to wrap his white lead in sale for painters. In that year he sent his printed offers to dealers and pharmacists for the first time. In 1765, those increasing demand encouraged Johann Michael Herbert to relocate his production facility and to build a two-story factory building nearer to the downtown Klagenfurt (at the beginning of today's Radetzkystraße), to which he added another wing in 1766. He replaced the pots by large brick chambers into which he poured water vapor, carbonic acid and acetic acid. Michael's older brother Joseph taught physics at Viennese university from 1758 and Michael father-in-law excelled as a Viennese wholesale merchant, therefore the empress Maria Theresa, her husband as well as sons Josef and Leopold paid a visit to Michael's manufacture on July 12, 1765. Two years later he became a baron (Johann) Michael by Maria Theresa's diploma dated February 28, 1767 »in consideration of his old noble knightly family, and of his sixteen years of faithful service. His productions enabled his elder brother Joseph Herbert to become the very first notable Semi-Slovenian researcher of bioluminescence as Klagenfurt (Celovec) and Tainach (Tinje) were still predominantly Slovenian in those times while the British noble emigrants steadily mixed with the locals. Joseph Herbert noticed that the Bologna phosphorus was shining after heating to the temperature of the boiling oil, and therefore he thought that it contained its own light, whose substantial nature resembled later Lavoisier's caloric. He did not have the luminescence for burning, but described it with a mushroom model, like before him Lagala (La Galla), Liceti and Kircher. In 1773 while his Jesuitical society was being suppressed, Herbert entitled his last paragraph Fire in form of light as freed from phosphorous substances, and the flames (Ignis forma luminis liberatur in phosphoris, et flamma). It was an effective end of his Discourse concerning the fire, its triple state embraced as an elastic fluid,

and heat effects, with the vibrated movement of its light separated from the bodies, when it is finally captured or brought forth from the absorbing body. Herbert cited Beccaria, Kunckel, Bolognese stone and phosphorus, Balduin's phosphorous Saxon topaz (in fact triboluminescent citrine as quartz much lighter than topaz, which is hydroxyl fluorosilicate of aluminium), and pyrophore of W. Homberg who used to be a Parisian associate of Nicolas's son Louis Lemery (Lémery, 1677-1743).

Herbert experienced very often, repeatedly and clearly that the air accessed the radiations of the existing phosphor's light. He therefore thought that the phosphor holds on the matter (of light) from the air, which is the elastic fluid material, to which the light is ensnared. It is initially more attracted and later radiates as much in vacuo or in the air while its matter is fully saturated with light emitted by rotting timber. As already shining by its worms and taints, it releases the things that went through it when it was exposed to the light. While during the day they are quiet and stifled, they begin to move in the time of the onset of the night, while increasing immediately. Upon cutting of the light emission for a long time from the mold of each body, it liberates the same equal light day and night. All the above is confined to the air, to be held by the matter alone, to which the light, ensnared as is to say, is not equal to transpiration of this emission by the body in the whole, or of its insides. The nature of putrefaction promotes the abilities which in the daytime and at peace have no such living power. Indeed, those fires radiate such curios light, which opens its passages by breaking out. It has no other effect on vapors of the radiating material accessed by the air, which held it entangled before leaving off³⁴⁵⁸. Herbert did not

³⁴⁵⁸ Quo experimento frequentissime repetito, multo iam apertius patuit, aeris, et huius recentis, accessum ad liberandam phosphori lucem requisitum exstitisse; rebar igitur, me tenere rem, aerem que id fluidum elasticum esse, quod ad materiam, cui lux irretita est, magis attractum, hanc suo accessu liberet, atque hinc tantum esse, cur in vacuo, cur in aere, iam huiusmodi materia saturato, non luceant phosphori, non ligna putrida. Lucentes iam vermes, infectaque, quae ad manum erant perlustrans, quum animaduertissem, horum lumen, quum interdiu quiescunt, restingui, prout noctis ingruentis tempore se mouere incipiunt, pastumque concedunt, ita augeri continuo; in putrescentibus vero iisdem insectis lucis emissionem diu, noctuque aequalem esse, rebar, lucis liberationem eodem, ac supra, modo ab aere haberi, fed materiam folum, cui lux irretita est, non aequaliter perspirare, huius emissionem aut corporis totius, aut intestino putrefactionis motu promoueri,

provide any pictures of luminescence in his otherwise nicely illustrated book. He described fire and light as the same material substance that is absorbed in luminophore resembling a sponge:

"Fire is liberated in the form of light from the flame". Herbert argued that the light emitted from the luminophore always had different observed colors than absorbed, but did not describe the difference in their intensity, which prevents the human eye's perceiving some weak luminescence.³⁴⁵⁹

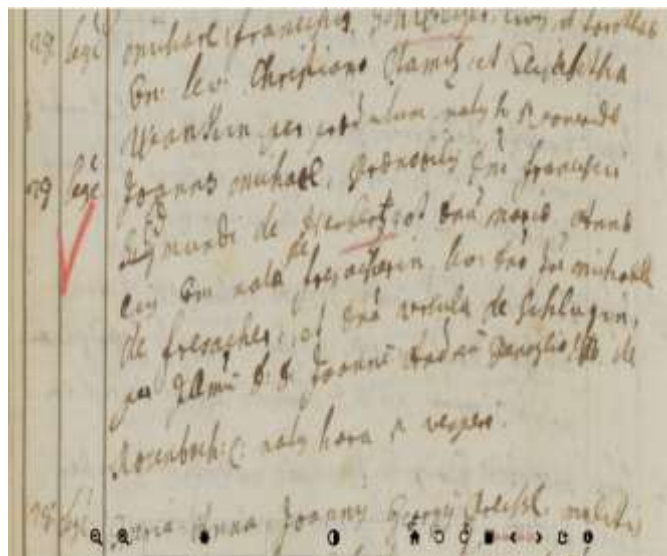

Figure 31-8: The birth certification of Johan Michael Herbert noted at St Egidius church in Klagenfurt on 28 September 1726

Ambshell stayed in contact with his professor Herbert later, and in 1778 he published a German translation of Herbert's Latin booklet about the compressibility of water, which he often quoted in his works.³⁴⁶⁰ The Florentine academy del Cimento declared water as incompressible, but a century later J. Canton with the help of his friend Henry Cavendish's father vice-president of RS Charles lord Cavendish (1704-1783) proved compressed water under the column of mercury in 1762 and

interdiu in viuentibus et quiescentibus nullam esse. Facto ab his ad ignes fatuos, ad lucem, quando que apertis ex cryptis erumpentem, transitu, neque hic deprehendi aliud, quam, quod vapores, materia luminis foeti (foetus), ad aeris accessum, quam irretitam ante tenere, lucem dimittant (Herbert, 1773, 164-165.)

³⁴⁵⁹ Herbert, 1773, 160-170; Harvey, 1957, 180, 333-334.

³⁴⁶⁰ Herbert, *Dissertatio de aquae, aliorumque nonnullorum fluidorum elasticitate*, Viennae 1773, Ambshell's translation Laibach 1778; Ambschel, 1807, *Dissertatio quinta de aere*, 179-180; Kayser, 1908, IV, 619; Harvey, 1957, 180, 333-334, 362.

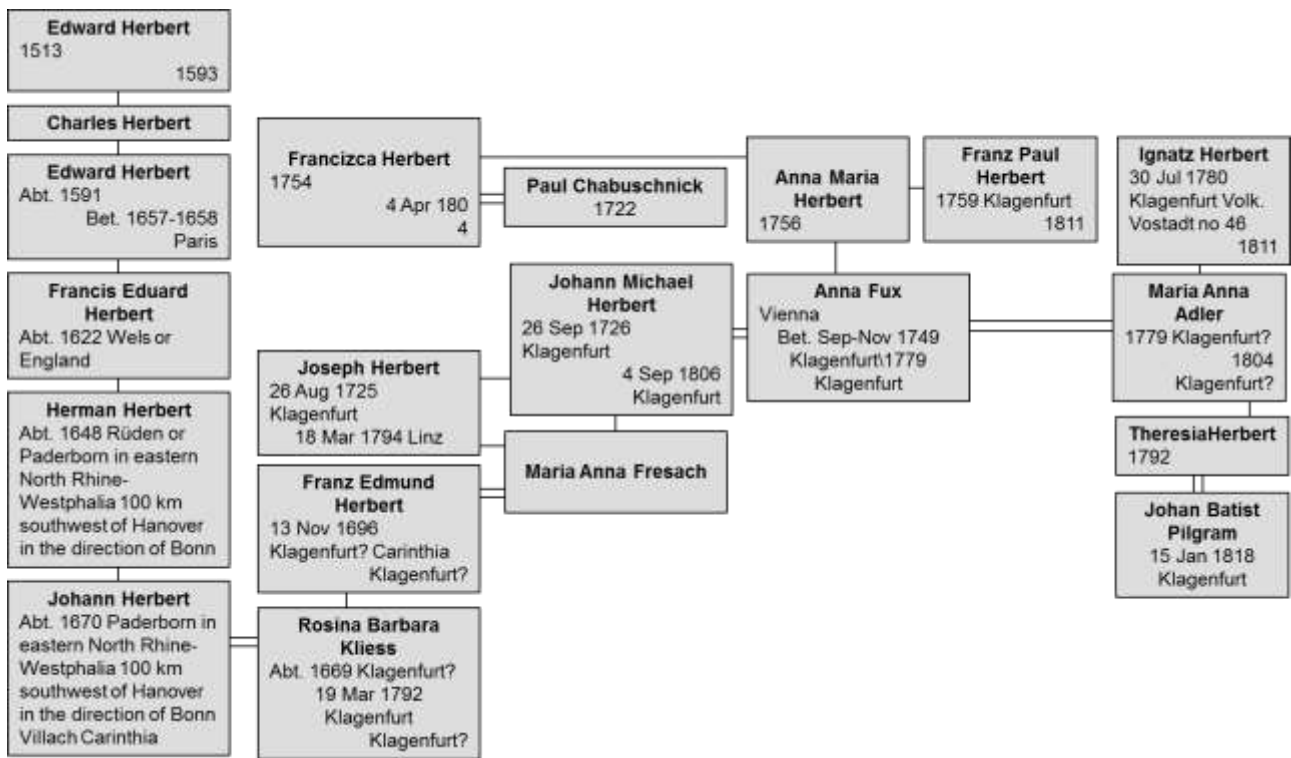

Figure 31-9: Ancestors of British-Habsburgian nobles Herbert

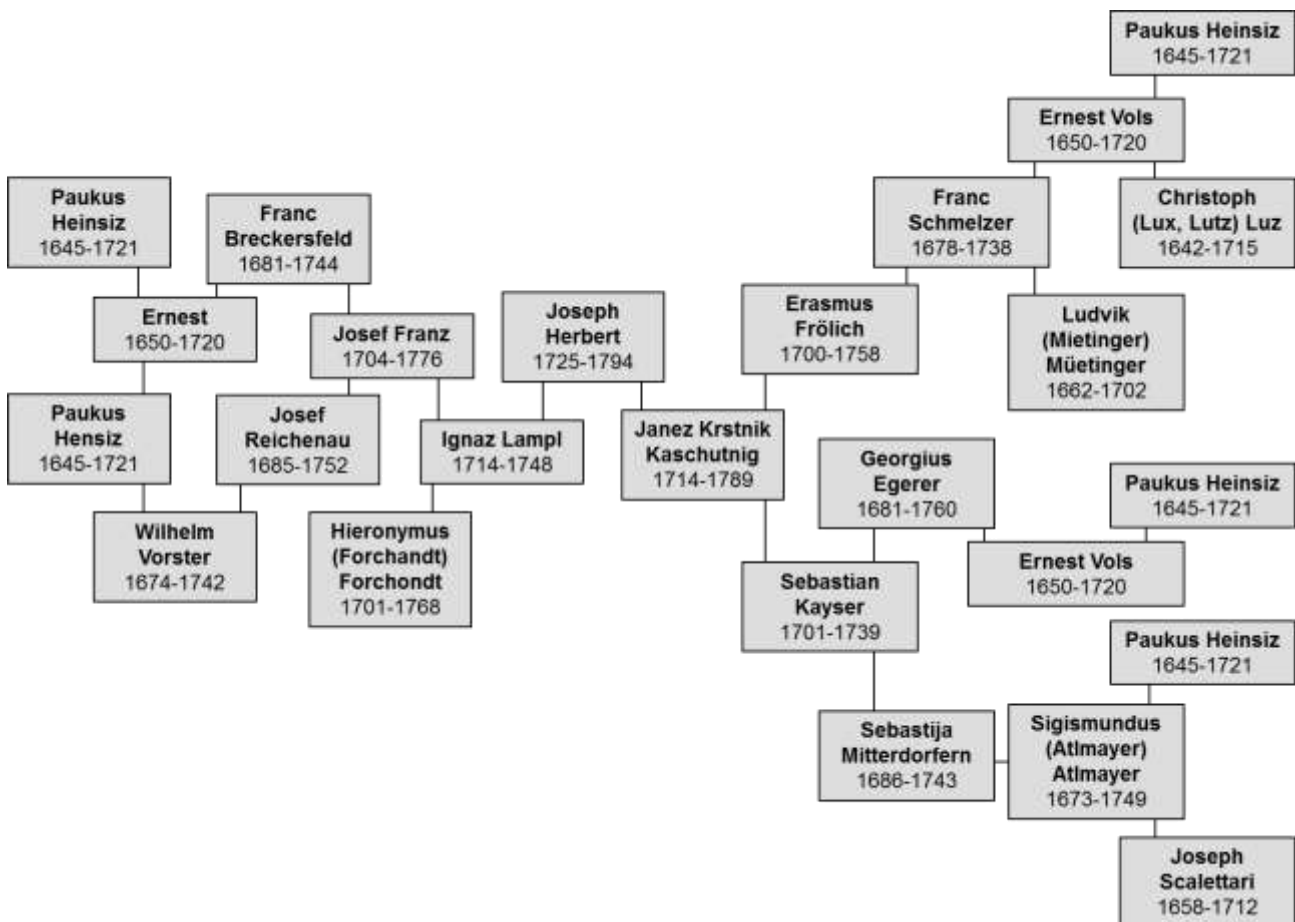

Figure 31-10: Academic ancestors of Joseph Herbert

1764. His work resembled J. Herbert's and Ambshell's experiments. By his own and his brother's British connections J. Herbert learned about J. Canton research of compressibility and luminescence. Ambshell cited Herbert as his professor in the description of luminophore even thirty years later.³⁴⁶¹

31.3 Research of Luminescence in Germany after the Discovery of Ultraviolet Light

The British-French colonial acquaintances with eastern invisibles strangely affected their romantic neighbours publishing in German and Latin languages with J. Herbert included. Few months after Hanover born musician of Jewish descent W. Herschel's determination of infrared light west of London, the apothecary and physicist member of the Munich Academy Johann Wilhelm Ritter (1776 Zamienice in Silesian southwestern Poland-1810) experimentally proved the ultraviolet light in Jena in 1801. His invisible rays just beyond the violet end of the spectrum even more effectively darkened silver chloride-soaked paper inside romantic Naturphilosophie of his friends Goethe, A. Humboldt, Hans Christian Oersted (1777-1851) or Schelling. Like Oersted later in 1819, Ritter searched for *Naturphilosophie* polarities in the several "forces" of nature, and for the relation between them inside Chinese yin-yang dichotomy adapted for German experimental business mind. A half-century of research later showed that the ultraviolet light is Maxwellian radiation of higher frequencies. It is invisible for humans, but it can lead to visible luminescence. Stokes then wrote that luminescence "gives physicist eyes to the observation of invisible light". In 1810, Goethe described colors in the fluorescent "lignum nephriticum" by his more artistic than physical approach. At the end of the book, he praised the experiments of his Baltic friend Seebeck performed in Jena since 1806. Seebeck is now more famous for his discovery of thermoelectricity in 1821.

Seebeck, with "special joy", confirmed Zanotti's assumption that each type of "Bologna stone" emits the light of a characteristic color, regardless of the color of the excited light.³⁴⁶²

According to Seebeck, the blue and violet color are an "exciting force" because they cause the phosphorescence to be as bright and powerful as white light. On the contrary, red and yellow light has the "depression power", as the luminescent substance, which would otherwise illuminate for several minutes, will lose its light after a few

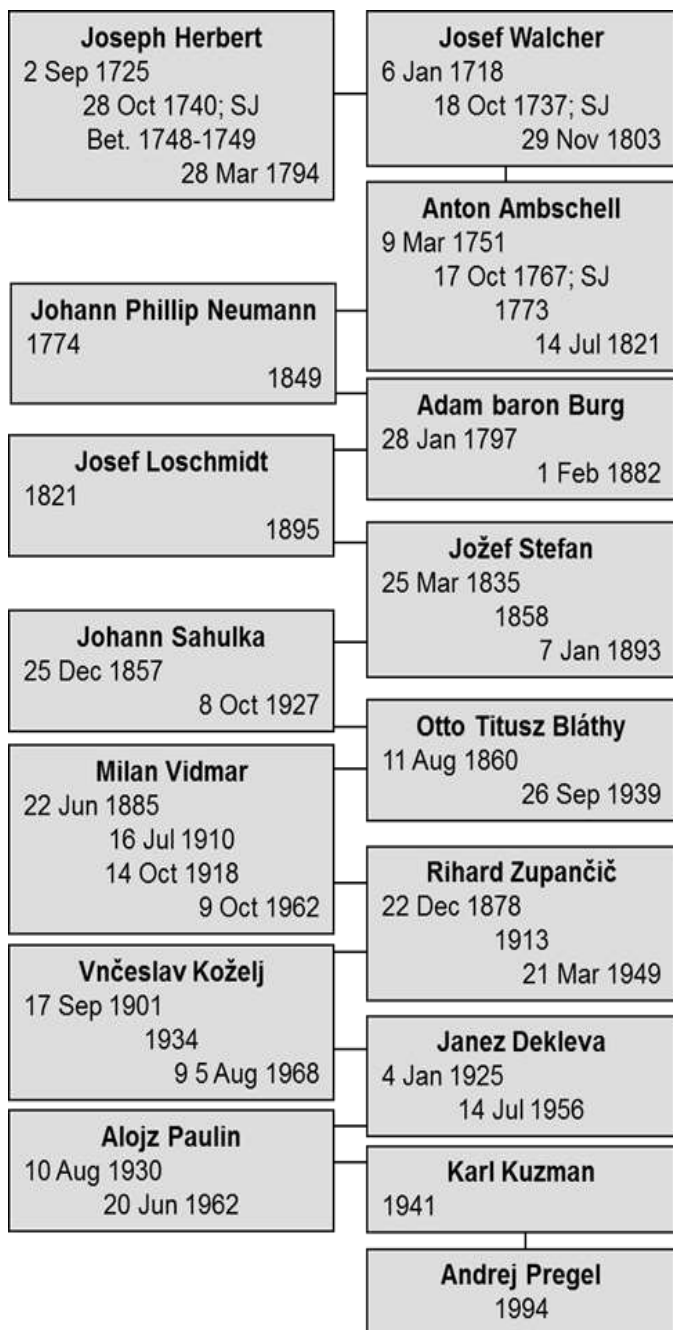

Figure 31-11: Joseph Herbert as academic ancestor of leading Slovenian vacuum researchers

³⁴⁶¹ Ambschel, 1807, 135.

³⁴⁶² Goethe, 1810, 710.

seconds of irradiation. He echoed the Chinese terminology where red is masculine yang while violet is more feminine yin to provide one of the first reports on stimulated emissions. Seebeck and his collaborator Goethe disliked Newtonian conclusion that white light consists of spectral colors.³⁴⁶³ Hegel's friend and Oersted's scientific companion Seebeck joined *Jenaer Romantikerkreis* of natural philosophers like Schelling, the biologist Lorenz Oken (1 August 1779 – 11 August 1851), leaders of romanticism in Jena the brothers Schlegel, electrochemistry expert Ritter, and many other outstanding personalities. The *Romantische Naturphilosophie* shaped Ritter, Seebeck and Oersted's scientific pursuits in progressive way even if it later dogged German erudite with its funny profound ideas coquetting with August Wilhelm Schlegel's (1767 Hanover-1845 Bonn) Indology of newly translated Bhagavad Gita published in 1823.



Figure 31-12: George Stokes (* 1819; † 1903)

The Benedictine monk Placidus Heinrich (born Joseph Heinrich, 1758 Schierling by Regensburg-1825 Regensburg) from the Abbey St. Emmeram in Regensburg observed phosphorescence through a small aperture in a dark room, like Jacopo Bartholomeo Beccari and Ambeschell. In 1791-1798 Placidus Heinrich taught physics, astronomy and meteorology at the university of Ingolstadt. In 1808, Placidus Heinrich's and the early Lavoisier's fan Heinrich Friedrich Link's (1767 Hildesheim in Lower Saxony-1851 Berlin) work was awarded with 500 roubles prize and printed in Petersburg

based on the award of Petersburg academy announced four years earlier. Heinrich divided the luminophores into five species as their phosphorescence arose from:

1. sunlight
2. combustion
3. it occurs on its own in plants and animals
4. pressure, cutting or friction
5. chemical reaction

Placidus Heinrich found description of the phosphorescence as a slow burning inappropriate because the most phosphorescence belongs to non-flammable substances. Later indeed, with the slow burning, only the light of the element of phosphorus was properly described, but not the real luminophores. Nevertheless, light is emitted during the phosphorescence while the oxygen is bound, but during the absorption of light the oxygen was supposedly released. That confused influences of oxygen mirrored Lavoisier's exaggerated claims about the roles of his beloved oxygen (acid maker) in all acids which was only slowly refuted by Davy's HCl and Liebig's almost final replacement of oxygen by hydrogen as acid maker. The development of European knowhow was never enough to change now deeply misleading oxygen's name, as names are always more persistent than truths in natural sciences including the divisible atoms and raising of immovable Copernican sun. Due to the change in color in phosphorescence, Heinrich rejected the explanation by repeated reflection of light in matter which Bošković and many others preferred earlier. Heinrich explained the phosphorescence after heating by the decomposition of the substance that releases Newton's material particles of light which T. Young tried to refute earlier, Goethe doubted in 1810 and Fresnel dismissed for almost a century soon after Napoleonic downfall. Therefore, Heinrich's optical Newtonianism was still in German mainstream during the peak of Napoleonic regime in 1809. On the other hand, Heinrich described the oscillation of the ether by analogy with the oscillation of the retina of the eye while absorbing the physiological colors. In 1809, due to this contradiction, the patriotic Parisian Institute did not award the 3000-franc award announced in 1808 to Placidus Heinrich's phosphorescence research praised in St. Petersburg, but to the lesser-minded French studies of Jean-Philibert Dessaignes (1762 Le Puy-en-Velay-1832 Vendôme in central France), director of the

³⁴⁶³ Nielsen, 1991, 143, 144-145.

boarding school in Vendome 150 km southwest of Paris.³⁴⁶⁴ In those times Placidus Heinrich was still a Benedictine monk because his monastery was not dissolved by Napoleonic armies in 1808 but only after 1810 which also affected the choices in Napoleonic Paris where the monks were still not universally welcomed despite of the concordat between Napoleon and the Pope signed in 1801. Even Dessaignes used to be the Oratorian monk, but the French revolutionaries dissolved his monastery despite of Dessaignes and other Oratorian support of the revolution, just like they later secularized Placidus Heinrich. The contestants advocated a completely different theory of light in the luminophore. Placidus Heinrich believed that the acidic fraction in luminophore causes light, while Dessaignes attributed a similar role to water. Few years younger graduate of the Parisian École Polytechnique Theodor von Grotthuss (1785 Leipzig-1822 Gedučiai in Lithuania) and Brewster unsuccessfully participated in that Parisian prize competition. Grotthuss in his triboluminescence research attributed the central basic role to electricity, after he proposed the first basically correct theory of electrolysis in 1806.

According to Placidus Heinrich, any color of absorbed light does not cause phosphorescence, for example, in diamond which was already popular in India for six millennia but gained European fans mostly after its great British advertising in 19th century. Riess continued Placidus Heinrich's experiments with diamond. In 1845 Riess confirmed the assumption of the English painter Benjamin Wilson (1721 Leeds-1788) of 1775, as well as the ideas of Germans Ritter (1805) and Seebeck (1806) that the blue light of greater refractive index (frequency) produces much more phosphorescence than red part of the sunlight.³⁴⁶⁵ Later, Riess severely polemicized about the nature of light in the cathode ray tube with Reitlinger from the Viennese Polytechnic who continued Plücker's and Hittorf's work.

³⁴⁶⁴ Wilde, 1843, 386, 406-407. Ten years later the dominance of Newton's corpuscular optics would no longer be so pronounced, as at that time Parisian academics had already rewarded Fresnel's wave theory of light, which later became the foundation of Stokes' work as the basis for a better theory of luminescence.

³⁴⁶⁴ Harvey, 1957, 201-202, 342.

³⁴⁶⁵ Riess, 1845, 335.

31.4 Exploration of Solutions of Fluorescent Materials in England: the Stokes Law

Goethe as a famous writer entered the field of optics as an artistic antagonist of Newtonian theory of colors. Goethe described the fluorescence of aniline as follows: "A solution of wild chestnut in water gains the blue color of the sky in the shortest time when we observe a glossy bottle on a dark background. When we place it against the light, we see the most beautiful yellow (color)".³⁴⁶⁶ In the mid-19th century, the erudite mostly studied fluorescence of fluorite; therefore Stokes even used the term fluorite to name the phenomenon.

In 1851, the English born John William Draper, a professor of chemistry at the University of New York, wrote about the fluorite irradiated by light of electrical sparks:

1. the volume of luminophore does not change,
2. the structure of the luminophore does not change,
3. the luminophores' surface changes as the mercury vapor condensation changes at the irradiated points,
4. In addition to the light, luminophore also undoubtedly radiates heat,
5. Isolated luminophore does not indicate electrical charging,
6. just a small amount of light is emitted during the luminescence,
7. the luminescent fluorite shines stronger, the cooler it was when irradiated.³⁴⁶⁷

In 1833, Brewster described a bloody red trace with a lens-directed beam in an otherwise green chlorophyll solution. A similar phenomenon was also observed in the fluorite solution. The English astronomer Sir John Frederick William Herschel did not know Brewster's work, since he was currently engaged in astronomical works and in his

³⁴⁶⁶ Goethe, 1810; Theodor Hoh, Zur Geschichte der Fluorescenz, Ann.Phys. 131 (1867) 659.

³⁴⁶⁷ Rosenberger, 1890, 472-473.

wife's botanical measurements in South Africa. In 1833 slavery was formally abolished in the middle of warfare Mfecane (Difaqane, Lifaqane) raging between 1815 and about 1840. In suburb of Cape Town Charles Robert Darwin (1809-1882) visited Herschel during his return trip onboard a ship Beagle to discuss natural selection on 15th June 1836 even if great promotor of revival of British science Herschel later rejected mystery of mysteries of evolutional Darwinism as the greatest British idea of Victorian times. Herschel was probably influenced by his wife who was a daughter of a Presbyterian minister, but he also resisted acceptance of the law of conservation of energy somewhat later by the sensible Indic philosophical argument that not all forms of energy were yet known and therefore the sum over them may be incomplete or testable. In 1845, Herschel observed the dark blue color of the illuminated surface of the transparent solution of American Quechua quinine sulphate in sulfuric acid at the spot where the light enters. The dispersion on the prism showed that its blue surface did not contain the red spectrum. He did not detect any polarization at his solution put between crossed tourmalines. The linearly polarized light from dichroic tourmaline might not have been his best choice because its dichroic effect is strongly wavelength dependent and the crystal appears coloured.

Herschel wrongly claimed that the "dispersive reflected" light can no longer turn blue the surface of the other solution. His false conclusion resembled Newtonian rightful claim that colours dispersed by prism cannot be dispersed again. By using a light of greater intensity or a less concentrated solution, Herschel would notice the blue light also in its interior.

In 1846, Brewster concentrated the light in a glass with a fluorescent solution by his strong focusing lens. He described the "internal dispersion" that was supposedly caused by the alleged double refraction (birefringence) at the crystals inside the solution. His special case was Herschel's "dispersive reflection". Luminescence inside the fluorite was already known before.³⁴⁶⁸

³⁴⁶⁸ Wilde, 1843, 399; Scotsman Sir David Brewster as professor of physics at the University St. Andrews and many years a secretary of Royal Society Edinburg, Edinburgh Transactions 16 (1846) 111. Translation: Ueber die Zerlegung und Zerstreung des Lichts innerhalb starre und

They needed the authority of W. Thomson's friend Stokes, the youngest son of the Irish priest, to resolve the dispute. Stokes studied at Cambridge, where he stayed for fifty-four years until his death. He also retained the Lucas Chair of Mathematics, where Newton once taught. Between 1854 and 1890, as the secretary and then the President of the RS, Stokes strongly influenced the development of British physics in the Victorian era.

In May 1852, Stokes lectured at the RS in London on the investigation of luminescence by two new methods: the luminescence of the filtered light was observed through a complementary filter, or illuminated by luminophore with the colors split into the spectrum, so that one could observe the difference between the absorbed and radiated light at any wavelength. "It was certainly a curious sight to see the tube instantaneously light up when plunged into the invisible rays; it was literally, "the darkness became visible"³⁴⁶⁹. Similar visible darkness appeared earlier in Fresnel's illuminated interference point in the shadow behind the obstacle needed to convince Poisson's Parisian doubts.

Stokes was aware of the significance of his discovery, and with his authority he also introduced a new name for it: "I am inclined to coin a term and call it fluorescence from fluorite (fluorspar, mineral form of calcium fluoride, CaF₂) as the analogous term opalescence is derived from the name of a mineral." The new name did not depend on the supposed radiation flow in Brewster's or Herschel's theory.³⁴⁷⁰ The results are summarized in "Stokes' law": the refractive ability (frequency) of fluorescent light is always less than the refractive ability of the light that caused it.

Stokes was awarded the Rumford Medal for his research. On June 27, 1856, he wrote to Herschel

flüssiger Körper, Ann.Phys. 73 (1848) 544; Franz Joseph Pisko (1827-1888), Die Fluoreszenz des Lichtes, Journal of Viennese real school Weiden, 1860, 40. Extended reprint of in a book: Wien, 1861, 11, 15; Sir George Gabriel Stokes (1819-1903), Das Licht, lectures in Aberdeen 1883-1885, authorised German translation of Otto Dziobek (* 1856, Frankfurt an der Oder; † 1919 Berlin), Leipzig, 1888, 277, 279; Kayser, 1908, IV, 851-852. Paragraph on fluorescence on pages 839-1214 by Heinrich Konen, associate professor of University Münster; Kudrjavcev, 1948, 501; M.N.Danilčeva (Moskva), David Brewster (1781-1868), in anthology "O fizikah", Mecniereba, Tbilisi 1979, 33.

³⁴⁶⁹ Harvey, 1957, 398.

³⁴⁷⁰ Harvey, 1957, 397; Pisko, 1861, 21.

about his funny analogies between the waves of the ocean and rays that produce fluorescence. His ships were analogous to particles of matter, and the impact of ships on waves were analogous to absorbing the incident rays, which always comes along with fluorescence. The waves that travel away from the ship were like fluorescent light. Stokes assumed that the force is in a simple ratio with the distance of the substance from the equilibrium position. It depends on the composition of the ether and the distance between the molecules of the substance. The oscillation amplitude is infinitely small in comparison with the size of the molecules. The period of oscillation of the molecules is different from the period of oscillation of the particles of the ether, and the frequency of fluorescence is reduced by decreasing the amplitude.³⁴⁷¹ A great praise of wave theories for Victorian ships' Rule the Waves Britannia!

At first, Stokes based his arguments on his theory of ether. Considering the cause of internal dispersion, he at once discarded all supposition of reflection and refraction of the vibrations of the luminiferous ether amongst the ultimate molecules of bodies as it seemed quite contrary to dynamic principles to suppose that any such causes should be adequate to produce vibrations of one period from the vibrations of another (frequency). Later, Stokes changed his opinion without giving up his law. However, in 1885 in Aberdeen he was not able to draw the right boundaries between fluorescence and phosphorescence.³⁴⁷²

Jožef Stefan soon challenged some Stokes' claims with his own measurements of polarisation. The analytical chemist James Alfred Wanklyn FRS translated Stefan's paper for abbreviated publication in *Phil.Mag.* The professor of chemistry at the London Institution from 1863 Wanklyn is mostly remembered today for his "ammonia method" of determining water quality. His translation was not published in *Intelligence and Miscellaneous Articles of Phil.Mag.* as were most of other Stefan's articles, but in main part of magazine.³⁴⁷³ There Stefan supported Cauchy's law while criticizing Jean-Baptiste Biot's law, also because Augustin-Louis Cauchy used to be a

friend of Stefan's supervisors Ettingshausen and Koller. In his footnotes to the translated Stefan's paper, George Gabriel Stokes, signed as G.G.S.,³⁴⁷⁴ stated that Stefan made an error by omitting his arbitrary constant after integration and by obtaining negative constant in dispersion formula, which indicated that Biot's law is still maintained in Stefan's experiments. Besides Brewster, Stokes was the greatest British expert in optics of those days and probably the initiator of that translation, while Stokes himself supposedly lacked sufficient knowledge of German language to translate himself. Stokes' criticism might have contributed to Stefan's abandonments of further research in optics after 1866, except for his two papers³⁴⁷⁵ which were not translated in *Phil.Mag.* where W. Thomson worked as an associate editor after July-December 1871. Stokes was close to Thomson who later befriended Stefan during the Viennese Electrical exposition in October 1883. Stokes' criticism may have had even some political motives as Cauchy used to be the most Catholic conservative of all top scientists, while his Parisian antagonist Biot remained the last valuable supporter of Newtonian corpuscular theory of light and furthermore Biot disliked aether. Cauchy widely travelled with the exiled French court, but mostly through Catholic states including Gorizia and Prague.

31.4.1 *Discussions on the Validity of Stokes' Law*

Besides Stefan, many other researchers discussed Stokes's claims in German language. In 1853, Anders Jonas Ångström (Angstrom, * 1814; † 1874 Uppsala) came to the opposite conclusion by experiments resembling Stokes's data. According to him, the atoms of the ether should even oscillate one octave higher and fluorescent light would therefore have a higher frequency than absorbed.³⁴⁷⁶

³⁴⁷⁴ Stefan, 1864, 139, 140

³⁴⁷⁵ Stefan, 1871, 223–245; Stefan, 1872, 325–354

³⁴⁷⁶ Anders Jonas Ångström (1814-1874), professor of physics and astronomy at the University of Uppsala, *Optische untersuchungen*, *Ann.Phys.* 94 (1855) 164; Sekulić, 1871, 80; Kayser, 1908, IV, 866. Paragraph about fluorescence on pp. 839-1214 was authored by Heinrich Konen.

³⁴⁷¹ Martin Sekulić (1833-1905), professor of Real School Rakovac, *Fluorescencija i calcescencija*, *Rad Jugoslovenske akademije* (Zagreb) 15 (1871) 80.

³⁴⁷² Stokes, 1888, 300, 301; Wilson, 1987, 112.

³⁴⁷³ Stefan, 1864, 137-140.

As the best in his 7th grade J. Stefan received the textbook of Wilhelm Eisenlohr (1799-1872) who studied the fluorescence in Geissler's tube and examined Helmholtz's color combination of fluorescence light in analogy with sound. He described fluorescence as an interference of blue-violet and ultraviolet light.³⁴⁷⁷

In 1859 and 1866 in now Polish Szczecin, Emsmann studied the experiments of "negative fluorescence" in which refractive ability (index, frequency) is expected to increase. In 1861 he compared fluorescence with hysteresis of iron. The irradiation could cause the motion of atoms in the body with a special "coercive force", which maintains the orderly arrangement of atoms. This coercive force is supposed to be strong in phosphorescent bodies and weak in fluorescence.³⁴⁷⁸

In 1864, the Hungarian Jew Károly Akin (C.K., 1830 Buda-1895 Rijeka (Fiume)) put fluorite on the air in his academical lab in Pest, where it radiated visible light for another one to two minutes after irradiation with thermal rays (infrared in modernized slang). In the same year, John Tyndall (1820-1893) independently noticed the "negative fluorescence" in the focus of his concave mirror, on which only infrared light had fallen. Akin called that phenomenon calcescence in analogy with fluorescence, while Tyndall coined the other term caloriscence.³⁴⁷⁹ As always in science, the battle between the different proposed terminology was an echo and companion of the battle among ideas themselves. As the professor in Pest, Akin was a neighbor of S. Šubic and Tesla's teacher M. Sekulić. On March 18, 1868, Akin was elected a correspondent of the Hungarian Academy

³⁴⁷⁷ Johann Conrad Bohn (1831-1897), professor of mathematics in central forester school of Aschaffenburg, Ueber negative Fluorescenz und Phosphorescenz, Ann.Phys. 130 (1867) 390.

³⁴⁷⁸ August Hugo Emsmann (1810-1889), professor of physics of real school in Szczecin (Stettin), Positive und negative Fluorescenz. Phosphorescenz und Fluorescenz, Ann.Phys. 190/12/114 (1861) pp. 651-657, here p. 654; Bohn, 1867, 386; Lommel, Ueber Fluorescenz, Ann.Phys. 143 (1871) 40; Rosenberger, 1890, 474-475.

³⁴⁷⁹ In 1865 Bohn assigned them a priority in the discovery to trigger a dispute between Emsmann (Prioritätsansprüche in Betreff der negativen Fluorescenz oder Calorescenz oder Calcescenz, Ann.Phys. 129 (1866) 352) and C.K.Akin from the physics cabinet of academy of science in Pest (Erwiderung auf eine Notiz des Hrn.Emsmann, Ann.Phys. 131 (1867) 561).

of Sciences. In 1872, he was a candidate for the parliament in Lipótváros part of Pest joined next year into Budapest. He failed on the elections but continued to publish political pamphlets alongside with fundamental physics. After 1872 in Vienna he invented the postcard but could not provide adequate financial resources to realize the idea which the Belgians introduced in 1882. In his fatal autumn Aikin killed himself in then Hungarian port Rijeka.

Eugen von Lommel (1837-1899) studied in Munich and habilitated at Polytechnics in Zurich. Between 1868-1886 he was a professor at the University of Erlangen and in 1872 he married there Luise Friederike Caroline Hegel (1853-1924) the granddaughter of the famous philosopher Hegel (1770-1831). He organized a new physical institute at Munich University. In 1893, he published an exceptionally successful experimental textbook, the 26th edition of which was published twenty-seven years later. From 1890 to 1894, Lommel attracted his friend Boltzmann from Graz to accept the chair of the professor of theoretical physics in Munich. After Lommel's death, his chair in Munich was occupied by Röntgen.³⁴⁸⁰

The native of Bornheim's merry red-light district of Frankfurt J.C. Bohn learned a lot as the Parisian Regnault's assistant in 1855. In 1867 in Bavarian Aschaffenburg Bohn announced that an increase in refractive index (frequency) of "negative fluorescence" occurs due to a rise in temperature rather than as a direct effect of absorbed infrared light. So, there would be no "negative fluorescence" and exceptions to Stokes' law. Akin criticized Bohn's arguments and at the same time proudly quoted Tyndall's claim that "the concept of the transformation of heat rays into light rays clearly belongs to Akin according to his first publication" which was also read by Charles Darwin. The Irishman Tyndall was always very fair to German language publications. Today, Akin and Tyndall seem to have justly proved that the infrared rays can sufficiently heat the body to radiate in the visible area, which does not concern luminescence.³⁴⁸¹

³⁴⁸⁰ Lommel, 1871, 32, 50; Harvey, 1957, 404; Höflechner, 1994, Part II, 139).

³⁴⁸¹ C. K. Akin, Ueber Calcescenz und Fluorescenz, Ann.Phys. 131 (1867) 556; Harvey, 1957, 399-400.

The following year J.C. Bohn announced that fluorescence depends on the nature of the bodies and the color of the absorbed light. The intensity of absorbed light does not affect fluorescence but affects the radiations of the heated body. Bohn described the fluorescence as "irregular refraction with a change of frequency".³⁴⁸² It was certainly a good try to link it with better known phenomena of light.

In 1871, the native of then Bavarian Edenkoben winegrowing areas near French border Lommel developed Eisenlohr's ideas to contradict Stokes' theory of fluorescence, according to which the frequency of the emanated light can increase because of resonance between the absorbed light and the body's own oscillation. In 1875 and 1876 in Bavarian Erlangen, he wrote that "every dark band of the absorption spectrum corresponds to the bright band of the fluorescence spectrum in the solution ... so, we can place a generally valid claim that the body fluorescents with the help of those rays that it absorbed ... The phosphorescence is an effect of absorbed light like a fluorescence". Lommel's unification was in the mainstream of earlier Faraday's unifications of all kinds of electricity and appeared simultaneously with Maxwellian unifications. Marriage into Hegel's family helped Lommel's success. His PhD student J. Stark graduated with his optical studies in Munich in 1897 but later somewhat ashamed himself in Nazis' headquarters.

Magnus' Berliner and Jamin's Parisian student the Swiss Hagenbach-Bischoff did not accept Lommel's assumptions and supported the general validity of the Stokes' Law.³⁴⁸³ His alleged "negative fluorescence" was supposedly associated with impurities and the incompleteness of the incident light. In 1878, Lommel described the absorption of light as a friction like the interaction between the molecules of the ether and the substance. Due to the lack of knowledge of the properties of the supposed ether, many researchers were not yet able to decide between Stokes and Eisenlohr-Lommel's theory.³⁴⁸⁴ The choice was certainly also nationally motivated while new

³⁴⁸² Bohn, Ueber negative Fluorescenz, Ann.Phys. 133 (1868) 173, 170.

³⁴⁸³ Jacob Eduard Hagenbach-Bischoff (1833 Basel-1910 Basel), professor of physics at the university of Basel, Versuche über Fluorescenz, Ann.Phys. 146 (1872) 81..

³⁴⁸⁴ Rosenberger, 1890, 479-480.

unified German state gradually challenged other older European powers by militaristic aggressions and by preferring wave interpretations of newly discovered rays. There was always a linguistic controversy: Johann Wilhelm Ritter called ultraviolet light "oxidizing rays" to distinguish them from "heat rays". The simpler term "chemical rays" was adopted soon afterwards, and remained popularity throughout the 19th century, although John William Draper named them "tithonic rays" by husband of Aurora Tithonus gained the immortality but not eternal youth with allusion to the visible effect of UV rays on photographic paper fading over time. The terms "chemical rays" and "heat rays" were eventually gradually abandoned dropped in favor of ultraviolet and infrared radiation. The luminescence and photography remained the principal tool of detection until Charles Thomson Rees Wilson's (1869–1959) Scottish cloud chamber perfected for radioactivity in 1911. Photomultipliers kind of vacuum tubes based on the photoelectric effect and the secondary emission were developed for RCA together with TV after 1934. Avalanche photodiode (APD) as a highly sensitive semiconductor photodiode can be regarded as the semiconductor analogue of photomultipliers invented by Japanese engineer Jun-ichi Nishizawa (西澤潤一, Jun'ichi, 1926 Sendai-2018 Sendai) in 1952. Only after 1960s operational liquid-crystal displays as the fourth phase of matter different from Crookes' fourth visions surpassed cathode ray tube luminescent displays, also in their total sales in early 3rd millennia.

31.4.2 *The Modern Theory of Stokes's Law*

Einstein provided a handy explanation of Stokes' law with its possible exceptions when he awarded it the first place among three examples of his use of photons in quantum theory in 1905.³⁴⁸⁵ Nowadays, the "negative fluorescence" is described by the anti-Stokes lines and we consider Lommel's correction of the Stokes law, according to which the maximum of the luminescence spectrum is shifted to lower frequencies with respect to the maximum absorbed spectrum. In 1887, it was found that the sulfides are not

³⁴⁸⁵ Albert Einstein (1879-1955), Über einen die Erzeugung und Verwandlung des Lichtes betreffenden heuristischen Gesichtspunkt, Ann.Phys. 17 (1905) 142.

luminophores in the pure state but must contain a small amount of activating metal. J. Stark's antisemitic buddy P. Lenard first described the distribution of ion activators in T. Sidot's blends and other crystals hosts in 1890. The ion activators are surrounded by host ions to form luminescent centers where the excitation and radiation process take place. These centers should not be too close together, so only the trace of the activator should be inserted into the host for the highest efficiency of the luminophore. In 1917 and 1918 Lenard announced that each group of lines in the luminophores spectrum would cause a different luminescence center. Twenty years later, Lise Meitner and Otto Hahn Berliner PhD student Nikolaus Riehl (1901 Saint Petersburg-1990 Munich) from the Auergesellschaft in Berlin criticized Lenard's presumptions and, together with afterwar Osram GmbH researcher Michael Schön (1903 Weisbaden-1960 Munich), developed the foundations of the modern quantum mechanical model of crystal luminophores in *Zeitschrift für Physik* in November 1939.³⁴⁸⁶ Certainly, the Jewish Meitner and Riehl could not be any great Lenard's fans even if they liked his physics, which they did not. Already then in the context of the German Atomic Energy Program Riehl was responsible for work on the purification of uranium since September 1939. After WW2 Riehl switched sides and spent a whole decade at Soviet bomb project as a son of Jewish-Russian mother and then taught technical physics at Technical University of Munich.

On 18 June 1903, in Kiel Lenard published the equation for the intensity of cathodoluminescence in dependence on the number and velocity of accelerated electrons. In the same year in once Lommel's Friedrich-Alexander University Erlangen-Nuremberg, Wehnelt noticed that the equation does not give acceptable predictions for low acceleration stresses, as Lenard measured as much as 10^{-7} times smaller density of electrons compared to Wehnelt's data.³⁴⁸⁷ In the years 1938 and 1939, Eugene Wigner's Princeton PhD student Frederick Seitz (1911 San Francisco-2008) at General Electric labs and the editor of his paper at *Philosophical Magazine* Nevill Francis Mott at

³⁴⁸⁶ Lea Županc Mežnar, *Luminiscenčne snovi* (I part 4, *Vakuumist* 16/3 (1996) 14-15.

³⁴⁸⁷ Kayser, 1908, IV, 700-701; Diploma engineer Felix Fritz, *Leuchtfarben, Geschichte, Herstellung, Eigenschaften und Anwendung*, Berlin 1940, 117, 121.

Bristol developed an electronic configuration diagram to understand Stokes' law.

Several generations of Parisian family **Becquerel** as well as Wiedemann from Germany successfully researched on physics chemistry. The later professor of physics at the Conservatory of Measures and Weights E. Becquerel, son of the president of the Parisian Academy Antoine Charles (1788-1878), was already famous in 1839 with his description of the electric current that light causes in some electrolytes. In the same year in 1839, together with his father and professor at the Parisian University Jean Baptiste Biot (1774-1862) E. Becquerel published a study of the transition of the light of spark through a colored screen. Biot was opponent of Fresnel optics, researcher of polarization, and winner of Rumford Medal in 1840. Such supporters helped then only nineteen years old E. Becquerel to bring the luminescence research to a higher experimental level within the next thirty years without deepening into the theory that he avoided with the polite but neutral phrase "the disturbance of the molecular equilibrium".

Becquerel acknowledged Stokes' law. Becquerel and Lommel did not distinguish between fluorescence and phosphorescence, like Stokes, who was looking for different mechanisms of disintegration for both, but Stokes was unable to distinguish those convincingly in his lecture at Aberdeen in 1885. E. Becquerel, on the contrary, did not accept Stokes' expression of fluorescence at all, since for Becquerel it does not characterize a special kind of phenomenon. In 1892 E. Wiedemann affirmed E. Becquerel's ideas with the conclusion that by changing the temperature itself, the phosphorescence can be changed continuously in fluorescence. Previously in 1888, E. Wiedemann mistakenly assumed that fluorescence is characteristic of liquids, while the phosphorescence happens in solids. Such an opinion prevailed two decades later because almost no phosphorescence was observed in liquids apart from Dewar's description of liquid oxygen phosphorescence in 1894. In 1925, with the improved phosphorus at Nikolaj Ernestovič Bauman Moscow State Technical University (BMSTU, Московский государственный технический университет им. Н. Э. Баумана) S.I. Vavilov observed an unconstrained transition

of fluorescence into phosphorescence in solids and very dense liquid solutions, and thus refused Stokes' efforts. He announced that phosphorescence is "forbidden" and therefore a slower transition from excited state into the ground state.³⁴⁸⁸ In modern books, we often read also E. Becquerel's claim that fluorescence and phosphorescence are the same appearance of different duration.

31.5 Exploration of the Phosphorescence of Solid Matter in France - E. Becquerel's Phosphoroscope

Like Placidus Heinrich, E. Becquerel also distinguished five causes of phosphorescence:

1. ordinary raising of temperature, often already below the red glow,
2. mechanical effects,
3. electricity (in cathode ray tubes),
4. spontaneous phosphorescence in animals and plants,
5. sunlight.

He attributed special rules to his last, most common type of phosphorescence:

1. violet and ultraviolet rays are most effective,
2. luminophores differ in the width and spectrum of their spectra,
3. the color of phosphorescence is characteristic of luminophore and does not depend on the color of absorbed light,
4. absorbed ultraviolet light causes phosphorescence of lower refractive index (lower frequency),
5. if we put luminophore in the dark, the phosphorescence will be weakened, and it will increase with the increased temperature,
6. an increase in temperature during radiation by sunlight reduces subsequent phosphorescence,
7. if the spectrum of light falls on paper coated with calcium sulfide, the number of spectral lines increases, as Herschel found in 1842.

³⁴⁸⁸ Harvey, 1957, 353, 355, 390, 408; Kayser, 1908, IV, 600, 646, 1025; Sergej Ivanovič Vavilov (1891-1951) & Vadim Leonidovič Levšin (1896-1969) from the institute of the biophysics in Moscow, *Die Beziehungen zwischen Fluoreszenz und Phosphoreszenz in festen und flüssigen Medien*, *Zeitschrift für Physik* 35 (1926) 925.

In 1857 in simultaneous publications in *Annales de chimie et de physique*, *Il Nuovo Cimento* and *Philosophical magazine*, E. Becquerel described the first version of his phosphor-scope, which consisted of two panels with openings for incident light and for observation. He could rotate the panels around their common axis. The openings were not the opposite, but rather displaced. He placed the plates in a darkened drum. Inside the intermediate space between the plates in the direction of the boundary of the two openings, he put the luminophore. When rotating the lever, the plate turned around through the toothed wheels so that the delay of the phosphorescence can be measured up to 1/2000 s after irradiation with the sunlight. That ingenious method of detecting small intervals resembled Coulomb's magnetic measurements by torsional balance equipped with a mirror in their same Parisian milieu almost a century earlier. Becquerel's phosphor-scope was perfected by E. Wiedemann, but even he could not measure the retardations of fluorescence.³⁴⁸⁹ With mechanical phosphor-scope it was possible to measure the duration of phosphorescence only down to 10^{-5} s. Today shorter times are measured with modern photoelectric methods.

Becquerel performed the first qualitative measurements with his phosphor-scope. Already in 1859, he announced that phosphorescence consists of very narrow bands or lines of discontinuous spectrum. His precise measurements of the luminescence spectra enabled many discoveries.³⁴⁹⁰

In 1860 he discovered that the intensity of phosphorescence is decreasing exponentially with time. After his death, his son Henri continued his measurements in 1891 and 1892, while the descendant of another family of physicists E.

³⁴⁸⁹ Kayser, 1908, IV, 706-709; Harvey, 1957, 355; Wiedemann, *Ueber Fluoreszenz und Phosphoreszenz*, *Ann.Phys.* 34 (1888) 1st. part, 450-460. (Biography: Eilhardt Ernst Gustav Wiedemann (1852-1928) was a son of a professor of physics chemistry in Leipzig Gustav Heinrich (1826-1899). After 1879 he helped his father in editing the leading German journal *Ann.Phys.* in Leipzig. His mother Clara Louise was born in 1827 as daughter of the famous chemist Eilhard Mitscherlich (1794-1863). She translated Tyndall's books about physics and about alpine tours in Alps. Therefore, E. Wiedemann like Becquerel, researched luminescence inside his extended family traditions. He served as a professor of physics in the Universities of Leipzig and Erlangen).

³⁴⁹⁰ Kayser, 1908, IV, 647-648.

Wiedemann published slightly different parallel results in Germany as Parisian antagonists. The significance of the discovery was only discovered when H. Becquerel measured radioactivity, which was subjected to the same rule during his investigation of the phosphorescence of potassium uranium sulfate in 1896. Later researchers advocated more complicated laws of decay, as various luminescence lines appeared with different half-lives.³⁴⁹¹

In 1888, E. Wiedemann introduced the name luminescence for all "light phenomena not exclusively caused by the rise of temperature", which was already the established definition of phosphorescence.³⁴⁹²

31.6 Cathodoluminescence

31.6.1 Discovery

The cathodoluminescence was discovered during exploration of discharges in dilute gases. Sir Humphry Davy (1778-1829) reported about the green phosphorescence of glass in 1822. More detailed research was carried out in the next generation, in conjunction with E. Becquerel's measurements in solids and Stokes' measurements in solutions. In 1858 and 1859, the Englishman Gassiot, Frenchman E. Becquerel and German Plücker independently described the greenish fluorescence of glass in the cathode ray tube. In 1839 E. Becquerel studied the effect of an electric spark on fluorite on which just few electrons fell due to poor vacuum. In 1859, he used a discharged container with sealed conductors and external electrodes. He measured at the pressure of a thousandth part of bar of sulfide of calcium, silfide of bromine or platin-cyanide. He noticed that the fluorescence near the cathode is stronger than in other parts of the tube, and even the color of the fluorescence was different near the cathode and the anode compared to other parts of the tube. Like in phosphor-scope, a greenish shine of glass was also observed in his cathode ray tubes. At first, he thought that this was a subjective perception, but later wrote that blue fluorescence appeared on the lead glass, as Gassiot published independently in 1858. Plücker described the phenomenon as "magnetic light" which could be moved with a

magnet. Gassiot wrote that he observed green fluorescence only in the English potassium flint glass, while blue fluorescence was observed on lead glass nicknamed crystal.³⁴⁹³

Dewar investigated the effect of heat, which aroused brief luminescence for short space of time. He mentioned Geissler, who first noticed the luminescence in exhausted vessel, where the gas remains bright for about 5 seconds after discharge. E. Becquerel and others attributed the occurrence to the residual traces of oxygen in a vacuum and the like. Geissler died on January 24, 1879, so he may have watched fluorescence in the cathode ray tube before Hittorf, though he detected it in gas and not on glass.³⁴⁹⁴

Hittorf described luminescence in a cathode-ray tube:³⁴⁹⁵ "... Slightly radiant rays fly over the distance of one foot inside a tube. The side of the glass that stops them fluoresces with bright green-yellow light and loses some transparency ... If we increase the number of voltaic cells, we get along with the described green fluorescence light in the form of a wider or narrower ring around the end of the cathode." And also:³⁴⁹⁶ "... (the spiral of pulsating discharges in the cathode ray tube) lie on the cone coat with its a peak opposite to the pole. We clearly distinguish two to three full turns (spirals).

When (rays) encounter a glass wall, they cause vigorous fluorescence ... Nice scene is shown to the eyes when we rotate (the spiral) by slowly shrinking the rheostat." Certainly, some artistic proudness was involved there almost a century before interesting physics of Manhattan bombers.

Hittorf found in his discovery the key to the secrets of luminescence.³⁴⁹⁷ "Anyone who will satisfactorily explain the layering observed at those experiments (with discharges in cathode ray tubes) will explain the most important aspects of

³⁴⁹³ Kayser, 1908, 691; Fritz, 1940, 114; Harvey, 1957, 207, 353-354, 411.

³⁴⁹⁴ Dewar (1888, I: 317), with no detailed note on Geissler's work which was published in 1868 without the terms like phosphorescence or fluorescence (Dewar, 1888, 1: 335).

³⁴⁹⁵ Hittorf, 1869, 199.

³⁴⁹⁶ Hittorf, 1869, 216. A modern reader might observe that Hittorf should have used the term "phosphorescence", as he did in his later papers

³⁴⁹⁷ Hittorf, 1879, translation 1889, 230.

³⁴⁹¹ Kayser, 1908, 717-718; Harvey, 1957, 356.

³⁴⁹² Wilde, 1843, 384; Wiedemann, 1888, 446, 448.

phosphorescence". And additionally:³⁴⁹⁸ "In optics, we distinguish two ways of secreting the light from the bodies: the first comes ... due to the increase in temperature in glowing. The low-temperature phosphorescence does not happen alone, but with the involvement of other sources of energy."



Figure 31-13: Figure: Crookes

In 1879, at the lecture at BAAS in Sheffield, Crookes described the cathode ray phosphorescence without knowing Hittorf's measurements published only five years later: "... The diamond is a ruby stone with the most prominent phosphorescence. We placed a collection of rubies in the form of pebbles in the cathode ray tube, and when the inductive current arose, rubies lighted up in a beautiful red (color) as if it were glowing." In 1881, E. Becquerel rightly demanded his own priority preceding Crookes' research of cathodoluminescence, although Becquerel himself thought he was observing the absorption of rays of light and not the cathode rays.³⁴⁹⁹

In the 1880s and 1890s, Crookes used "spectral camera" of his own design to study Fraunhofer's cathodoluminescence lines of "rare earths", which he mistakenly took for non-elementary. The son of a wealthy family of cognac producers from the French province bearing his own name Paul Émile Lecoq de Boisbaudran (1838-1912) supported the opposite opinion. He had his own laboratory at the

³⁴⁹⁸ Hittorf, 1884, 131.

³⁴⁹⁹ Hittorf, 1879, translation 1889, 224; William Crookes (1832-1919), *Sur la matière radiante*, *Ann.Chem.Phys.* 19 (1888) 195-231. Reprint in Abraham, 1905, 116-117; Kayser, 1908, 691.

age of twenty. In the ore of zinc from the Pyrenees, Lecoq discovered a gallium on August 27, 1875, which he named by the Latinized name of his French homeland as well as by the Latin translation of his surname Lecoq. Later, he learned that he was dealing with an eka-aluminium, described by Mendeleev at a meeting of the Russian physicochemical society on 3 December 1870. Between 1879 and 1886, during the spectroscopic exploration of cathodoluminescence, Lecoq identified lines of previously unknown elements of rare earths (lanthanides): samarium, gadolinium, and dysprosium. In 1886 Lecoq and E. Becquerel published in parallel their investigations of luminescence in discharges at dilute gases.³⁵⁰⁰

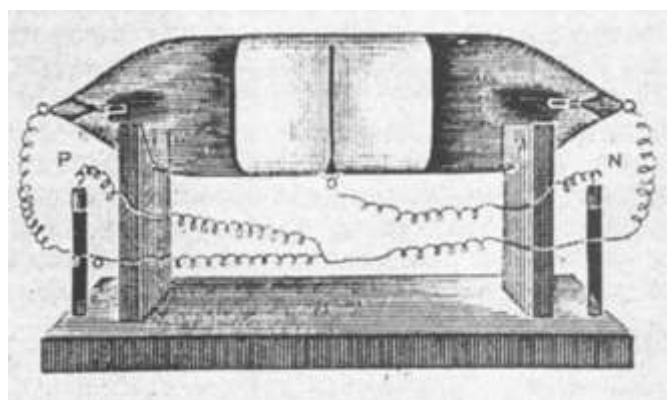

Figure 31-14: Figure: Crookes's apparatus.

The later pioneer of television research Campbell Swinton continued those researches of the rare earth's cathodoluminescence. After Röntgen's discovery, with the mediation of Lord Kelvin, Royal Society published Campbell Swinton's research of the cathode-ray tube between 1896 and 1899. On 27 February 1897, he confirmed that X-rays originated from the area of green luminescence of the cathode ray tube and he investigated the cathodoluminescence of charcoal.

Two years later the changing pressure and the type of gas in his cathode ray tube showed that in the case of cathodoluminescence of rare earth we obtain different luminescent colors than by heating with a Bunsen's burner. In some rare earths including thorium Campbell Swinton observed cathodoluminescence, but not in others like cerium, although they are equally bright when heated to the same temperature. The phenomenon is called Cando-luminescence. It used to be an important topics before the introduction of electric

³⁵⁰⁰ Kayser, 1908, 693, 795.

lighting with most artificial light of those days produced by fuel combustion, but in 1950s it was more relevant to explain it with selective thermal radiation than with the luminescence. The Cando-luminescence is not always simply due to selective thermal emission, but the mechanisms vary depending on the materials involved and method of heating.

In his later reflections on the television set, Campbell Swinton was aware of the need for a "sensitive fluorescent display."³⁵⁰¹ His Scottish visions certainly became true.

At the end of the century, the first approaches to modern theory were published during the exploration of cathodoluminescence. On 26 June 1894, Goldstein published measurements of the fluorescence of chloride of alkali metals evaporated on a smoothed plate 14 cm away from the cathode inside cathode ray tube. He assumed that "particles (bodies) are removed from their normal position or from their motion by strong external vibrations after irradiation... It appears that particles are transferred to a different position through phosphorescence without chemical changes. Those states are mostly rather labile, so the particles eventually return to their basic or less labile condition."³⁵⁰² Goldstein's note strongly resembles the excited states of the atom described few years later in quantum mechanics. Certainly, the designers of quantum novelties read Goldstein's data in their student years...

31.6.2 Radioluminescence

On 28 December 1895 Röntgen described his observation of the X-ray fluorescence on the paper screen in a cathode ray tube beam coated with barium platinocyanide BaPt (CN)₃, which he received from Lenard. In January of the following year, many believed that Röntgen produced a new fluorescence research. On May 2, 1896, Mihajlo Pupin (1858-1935) photographed a luminescence

³⁵⁰¹ Stokes, 1888, 116-117; Wilson, 1987, 194; Campbell Swinton, On the Luminosity of the Rare Earths when heated in Vacuo by means of Cathode Rays, Proc.Roy. Soc.London 65 (27. 4. 1899) 119; Campbell Swinton, Distant Electric Vision, Nature, 18. 6. 1908, 151; Harvey, 957, 377.

³⁵⁰² Eugen Goldstein (1850-1930) from Berlin, Ueber die Einwirkung von Kathodenstrahlen auf einige Salze, Ann.Phys. 54 (1895) 372, 373, 378, 380.

screen in the United States on which X-ray reflected the image of an hand shot through, a welcome topic for the former wild west. This greatly reduced the exposure time required for direct photographing of X-rays. Only two months after Röntgen's discovery, T. A. Edison has already been researching X-rays in hundred and fifty different cathode ray tubes. He examined many substances while he changed electrodes and the gases left in the vacuum to measure the permeability of various substances for the rays. Thus, he could greatly lower the price of Crookes' cathode ray tube. He tested nearly 1,300 substances to get the best luminescence for X-rays, even if he slightly exaggerated his sensational merits to amaze the publics. On 13 March 1896, he decided to use calcium tungstate (Scheelite) for his fluoroscope and five days later he published a report in the journal Electrical Engineer. He found that the X-rays do not cause fluorescence in relatively dense substances fluorescent that they used until then, but also in rarer ones like ammonium salicylate. Although he obtained good pictures and did not patent his discoveries, the physicians preferred to use more permanent photographs instead of less handy temporarily visible luminescence. Edison's reflections on the nature of X-rays were not accepted, but his experiments later enabled the fluorescent lamp.³⁵⁰³

The son of the late president of the Parisian Academy, H. Becquerel, "has come to the idea of seeing whether the characteristic of radiated rays is intimately associated with phosphorescence since the first time he learned about the discovery of the X-ray of Professor Röntgen." The idea was also adopted by other Parisian academics who reported on the research of various phosphorescent materials at their meetings. Jules Henri Poincaré (1854-1912) suggested on January 20, 1896: "Would you research if all bodies in which the fluorescence is strong enough do not emit, besides the visible light rays, also Röntgen's X-rays, regardless of the cause of their fluorescence ... It's not very likely, but it's possible and very easy to verify". Together with H. Becquerel they wondered whether X-rays were not radiated together with ordinary luminescence. As the glass of X-ray tube showed green luminescence like crystal uranium, Poincaré advised H. Becquerel to investigate the photoluminescence of potassium

³⁵⁰³ Israel, 1998, 309-310, 387; Fritz, 1940, 94; Harvey, 1957, 416-417.

uranium sulphate on 24 February 1896. Jules Henri Poincaré was a brother-in-law of conservative historian of sciences Emile Boutroux and a first cousin of even more conservative French anti-German prime minister Raymond Poincaré (1860-1934) who might have prevented Nazis' wars. Therefore, Jules Henri Poincaré's opinion was obligatory even if he rejected G. Cantor's transfinite numbers and Indic actual infinite and wasn't a great fan of logics. As early as 1872, H. Becquerel's father measured that uranium salts luminescence 0.001 s after illumination. For a dozen years, excellent preparations of uranium compounds, sealed in glass, have been waiting for a researcher at the Parisian Muséum. On 1 January 1896, H. Becquerel wrote with his real or slightly staged surprise: "Observations suggest that this unusual phenomenon cannot be attributed to the radiation of light in phosphorescence since that radiation would have to become so weak that it almost certainly couldn't be detected after 0.01 s".³⁵⁰⁴ The discovery was called radioactivity, and for it H. Becquerel received the Nobel Prize in Physics in 1903.

On March 19, 1903, Crookes described an experiment in which the grain of radium salts was placed at the end of a metal thread at the distance of about 0.5 mm from the screen of Sidot's blende. While observing through the magnifying glass, he noticed "the real rain of bright spots that appears and disappears and give the screen the appearance of the sky with its stars." Because thin-walled obstacles prevented scintillation, he correctly concluded that they were caused by alpha rays baptized by Rutherford and Villard four years earlier. Crookes called his device a spintharoscope.³⁵⁰⁵

In 1910 in Rutherford's laboratory in Manchester, Marsden proved that the active centres producing scintillations had the size of the molecules and therefore do not show the lightings caused by any mechanical split of small crystals with rays α .³⁵⁰⁶ Together with Geiger, they bombarded the zinc blende (ZnS) with alpha particles and watched tiny scintillations in the improved Crookes' device

through a microscope. With unexpected scintillations of the reflected α -rays, luminescence enabled the discovery of a solid atomic nucleus, it helped the discoveries of the X-rays, radioactivity, electron and Braun's cathode ray tube between 1895 and 1897. The modern physics was based on luminescence observations, as Stokes prophetically predicted. Later, it turned out that the northern lights are also due to the radioluminescence of charged particles, which the Sun shines in the high layers of the Earth's atmosphere.

31.6.3 *Cathodoluminescence in Braun's Cathode Ray Tube and Television Displays*

In 1878 as a professor in Marburg Braun continued with Hittorf's studies of electrical conductivity of gases. He was also interested in X-ray luminescence. In 1897, he placed a screen of mosaic coated with a phosphorescence paint on the axis of the enlarged part of the cathode ray tube, and first observed the variable flow of "cathode rays".³⁵⁰⁷

Initially, they used the luminophore CaS at Braun's Physical Institute in Strasbourg. On 26 September 1899 Braun's assistant Zenneck announced that cathodoluminescence of CaWO_4 is easier to photograph compared to the green CaS, especially during weak discharges, when the luminescent point travels quickly across the screen. He also recommended it for use in X-ray photography, and Zworykin patented it as a blue luminophore for color television in 1925.³⁵⁰⁸

Codelli, as the first in Slovenian areas, described a "fluorescence display in an image-processing cathode ray tubes" in his television design with a cathode-ray tube for the US market. He assumed that the "reception of the image" can also be used to "separate spaces filled with diluted gases that fluorescent in different colors..."³⁵⁰⁹

³⁵⁰⁷ Braun, 1897, 552, 553; Braun, 1898, 368.

³⁵⁰⁸ Jonathan Zenneck (1871-1959), Eine Methode zur Demonstration und Photographie von Stromcurven, Ann.Phys. 69 (1899) 842-843; Zworykin, Improvements in or relating to Television Systems, patent in USA 13. 7. 1925 no. 1,691,324, patent no. 255,057 applied in Britain on 3. 7. 1926 under no. 16,736/26, granted-accepted on 31. 3. 1927, 5.

³⁵⁰⁹ Codelli, AS, box 19, 60, 79.

³⁵⁰⁴ Henri Becquerel (1852-1908) from Muséum d'Histoire naturelle in Paris, Recherches sur une propriété nouvelle de la matière, Paris 1903, 4, 8, 12.

³⁵⁰⁵ H. Becquerel, 1903, 268; Fritz, 1940, 204.

³⁵⁰⁶ Lawrence Badash, Ernest Rutherford and Theoretical Physics. In: Kelvin's Baltimore Lectures and Modern Theoretical Physics (ed. Robert Kargon, Peter Achinson), The MIT Press, 1987, 364..



Figure 31-15: Ferdinand Braun (* 1850; † 1918).

With Röntgen's discovery, the production of luminescence screens increased significantly, including $\text{BaPt}(\text{CN})_4$ and many others. In 1931 Telefunken patented the use of a blue luminescence screen of zinc sulfide with copper or manganese admixtures, which exceeded the luminosity of tungsten compounds two to three times. In the same year, Telefunken patented a more useful blend of zinc sulfide admixed with zinc cadmium sulfide. In 1931, the willemite was also used for television screens at the labs of RCA. Since 1931, after successful Zworykin's interview, Humboldt Walter Leverenz has been working in RCA as one of the leading modern researchers in the use of crystalline luminophores in cathode ray tube. Humboldt Walter Leverenz was born in Chicago in 1909. After graduating from Stanford in 1930, he specialized his education at Münster where the expert spectroscopist enemy of Nazis Heinrich Konen's (1874 Cologne-1948) used to work earlier. In 1954 Leverenz received the Franklin's Award and became the director of the physic-chemical laboratory at RCA.³⁵¹⁰

³⁵¹⁰ Fritz, 1940, 99, 196, 201, 203.

31.6.4 A Description of the First Luminophores Used for Television Displays

The smelting and extraction of impure zinc by reducing calamine with wool and other organic substances was accomplished in India in the 13th century and later in China which is the greatest modern producer of zinc. The large deposits by the Lake Titicaca were and are still used. Only in the middle of the 18th century, German researchers assumed that natural ZnS could be a luminophore. The first artificial synthesis of zinc blende (sphalerite) was described by the Frenchmen Henri Étienne Sainte-Claire Deville and Troost in 1861. Its yellow luminescence was described only by the young chemistry preparer-assistant (préparateur) at Lycée Charlemagne in Paris the Frenchman Theodor Sidot, who heated the porcelain tube with zinc oxide in the atmosphere of sulfuric acid in 1866 to attract Becquerel's attentions. The zinc sulfide with copper admixtures ($\text{ZnS}:\text{Cu}$) crystallized on cooled parts of the tube, which, under the name "Sidot's blende", became the basis of many important industrial luminophores, and later television displays but it did not prevent Sidot's injury in war against Bismarck's Prussians in 1870. In 1893 Nikola Tesla described strong phosphorescence of zinc sulfide with addition of few ppm of suitable activator.

In 1868 the later founder and first president of Bern photographic society Aimé Forster (1843 Beringen in Switzerland-1926 Bern) published the detailed instructions for the synthesis of many luminophores, including the blue "Balmain's luminous paint", which was established on the market as the first widely known luminescent paint in 1870. In June 1907, that same professor of astronomy and physics and director of the Physical institute Observatory in Bern Aimé Forster returned Einstein's relativity paper delivered as a proposal for Einstein's post at Bern University with the comment "I can't understand a word of what you have written there." He proved that the expert in luminescence need not to be an expert in relativity which might also apply to Tesla's criticism of Einstein. Balmain was former teacher at the University college of London transformed into a manufacturing chemist at Greenbank Alkali Works St. Helen in Lancashire of inventors Henry F. Ihlee & William L. Horne of London. Edward Turner's (1798-1837) Londoner

student William Henry Balmain (* 1817 in then British now German Helgoland North Sea island spa; † 1880 Ventnor at English isle of Wright) patented the procedure for production of his colour in England with a patent no. 4,152, dated November 7, 1877, and founded a company that began selling it at the price of 110 German marks per pound. For binding, he used pure gelatine without water. When the price was lowered to acceptable 4.5 marks, demand for luminescence increased significantly. In 1886, the French inventor of the first commercially viable process for the manufacture of synthetic gemstones Auguste Victor Louis Verneuil (1856 Dunkirk-1913) found that in Balmain's paint the essentially calcium sulfide had admixtures of metals, especially bismuth. Balmain's paint is basically the same as the older Balduin's "phosphorus hermeticus" and Canton's oyster shells³⁵¹¹ therefore it connects a great ancient Chinese knowhow with modern technology.

In 1906 at City College of New York, Charles Baskeville (1870 Deerbrook, Mississippi-1922 New York) found that the manganese-doped (manganese-activated) willemite Zn_2SiO_4 is a fluorescent phosphor material with green to yellow emission. He discovered its sensitivity to X-rays and rays from radioactive sources in 1904. Instead of manganese in artificial production we now also use rare earths, for example, iridium.³⁵¹²

31.7 Bioluminescence and Chemoluminescence

All roads and belts lead to China. The bioluminescence has already been described by the Chinese over 5000 years ago while Aristotle learned about it mostly by his student Alexander's Indic campaign. The Indonesian cultures used luminescent properties of mushrooms as improvised torches as reported to Westerners by the botanist Georg Eberhard Rumphius (Rumpf, 1627 Hessen-1702 Indonesia) of the Dutch East India Company while the Micronesian cultures incorporated luminescent fungi into ritual dress

³⁵¹¹ Aimé Forster, Ueber Darstellung künstlicher Leuchtsteine, *Annalen der Physik und Chemie*, (1868) 209/1: 94-121; Kayser, 1908, 751, 827; Fritz, 1940, 29-30, 179; Harvey, 1957, 147.

³⁵¹² Fritz, 1940, 99, 145; Kayser, 1908, 837.

and face paint. In 1655 Olaus Magnus (Olof Månsson, * 1490 Östergötland; † 1557 Rome) as the bischof of Uppsala described the practical use of mycelia-infested bark (Foxfire) by Scandinavians during long winter nights. Well informed as the business collaborator in Indic trade, Boyle proved oxygen consumption in bluish-green "foxfire (Congolese chimpanzee fire)". The glow of those mushrooms is also caused by the decomposition of plant matter while their fungal growth was determined as source of their glow only in 1823. In 1667 Robert Boyle had further shown that light worms stop emitting light when placed in a vacuum while their lighting returns in the air, if they survive the crude treatments of those days. Rudolf Albert von Koelliker (Kölliker, * 1817 Zürich; † 1905 Würzburg) and his former Würzburg assistant Franz von Leydig (* 1821 Rothenburg ob der Tauber; † 1908 Rothenburg) had studied the fine structure of the luminous organs of the firefly in Tübingen in 1857 while Louis Pasteur (1864) and the LGBT Darwinist Sir Edwin Ray Lankester (1847 London-1929 London) in 1870 researched bioluminescence with its spectra of the emitted light included. August Kekulé perfectly trained his Flemish Ghent student Leonard Bronisław Radziszewski (pseudonym Ignacy Czyński as Polish fighter for independence, 1838 Warsaw-1914). Radziszewski became an assistant professor of chemistry at the Institute of Technology in Habsburgian Krakow and later in 1872 a professor of general and pharmaceutical chemistry at Lvov University where he first lectured in Polish language. Radziszewski was the first to report on the chemiluminescence of the solution during self-oxidation in Krakow and Lvov in 1871 and 1877 as the pioneer of Habsburgian researches of luminescence during Karol Olszewski's studies of chemistry at the neighbouring Krakow Jagiellonian University in 1866-1872. In 1885 and 1887 in Parisian Sorbonne and Lyon Raphaël Dubois (1849 Le Mans-1929) found that the crude extracts derived from the common piddock (*Pholas dactylus*) emit light when mixed, with no phosphorus involved. He discovered luciferin in 1887. The piddocks use a mixture of luciferin and luciferase, which is the basis of all bioluminescent phenomena. Their glows resemble the yellowish-green light of Eurasian *Lampyris noctiluca* or Dubois' research of American *Pyrophorus noctilucus* (western Indian Pyrophores) about which Schöttl had asked his students in Ljubljana a century earlier. In 1904

his consideration of radioactivity persuaded Dubois that the distinction between "matter of life" and "living matter" is superficial.

After copying bird's flying, dolphins' diving, moles' digging mines, torpedo fish's (electric rays) electricity, hedgehogs' and wheel spiders' rolling, the humans finally decided to copy bioluminescent species. The first effective chemiluminescent materials without organic ingredients were synthetic compounds such as luminol (luminol). Its blue chemiluminescence upon oxidation in blood was first described by Herbert Otto Albrecht of Kaiser-Wilhelm-Institut für Physikalische Chemie und Elektrochemie at Berlin-Dahlem for Ostwald's *Zeitschrift für Physikalische Chemie* in Leipzig in 1928.

31.8 Research of Luminescence in the Habsburgian Monarchy and in Slovenian Areas

Vienna was never the sole Habsburgian centre of learnings with Radziszewski's chemiluminescence in Krakow and Lvov, August Witkowski, Karol Olszewski and Wroblewski's Krakow condensation of gases, Władysław Natanson's Krakow statistical mechanics, Smoluchowski's Lvov kinetic theory of molecules developed in 1898, Mach's Prague University colleague during Tesla's studies in Prague Friedrich Reinitzer's (* 1857 Prague; † 1927 Graz) discovery of rodic liquid crystals in Prague in 1888 by collaboration with O. Lehmann. But Vienna influenced other as center of Bošković's physics and later of kinetical atomism of Smoluchowski's teacher J. Stefan. The first important Habsburgian luminescence research was published in Vienna by professor of experimental physics the Jesuitical follower of Bošković Herbert in 1773. In Vienna, the research assistant of the Imperial-Royal Mineral Collection, Ettingshausen's son-in-law Grailich, continued the research of luminescence. The Viennese academy awarded his book about crystallographic and optical research on 30 May 1857. He devoted a special chapter to the exploration of luminescence, especially in solid state. He used Herschel-Brewster's method, with Stokes' supplements, in an equilateral cylinder of diameter and height of 2 cm. Like Stokes, he noticed that the fluorescence of some crystals may be polarized after its exciting

with unpolarized light. During the observation through William Nicol's (1770-1851 Edinburgh) prism, he also described "Doppelfluorescenz", a phenomenon related but distinct from dichroism, which makes the colors of the luminophore different depending on the direction of incidence of light relative to the crystallographic axis. Lommel (1879) and E. Wiedemann (1880) also studied that phenomenon.³⁵¹³

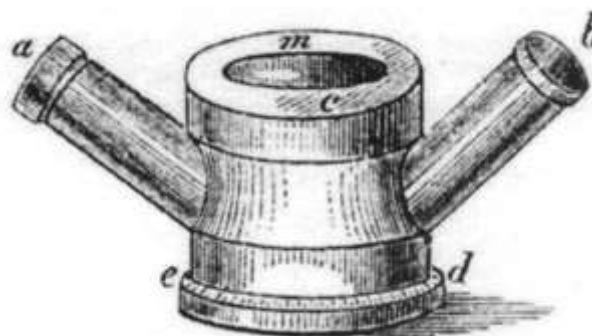

Figure 31-16: Grailich's experimental tools.

After Grailich's death, Stefan became Ettingshausen's successor at their physical institute. Stefan's research started in collaboration with physiologist Ernst Wilhelm Brücke, who investigated the opacity of the lens and cornea of our eye for ultraviolet light which causes luminescence in 1845 and 1846. The Viennese physician-physicist Pierre, who moved from Prague to replace Ferdinand Hessler at Viennese Polytechnic in 1867, headed the measurements of the limits and maximums of fluorescence spectra. E. Mach took over Pierre's Prague chair and well-equipped lab with thousand tools. For nine years, Pierre was concerned with the question "Can dark rays, i.e., heat rays (infrared) whose wavelength is longer than the extreme red rays, also cause fluorescence?" Pierre's answer was affirmative as support of "negative fluorescence". Pierre continued Stokes' measurements of chlorophyll and received preparations from Vienna and Frankfurt. He wrote that Stokes' law is useful for "simple", but not for "composite" fluorescence, which gained Lommel's approval. With the same excitation light, the fluorescence spectrum was always the same, but dependent on the pH of the

³⁵¹³ Joseph Grailich (1829 Bratislava - 1859 Vienna), privatdocent of Viennese physics Institute, *Krystallographisch-optische Untersuchungen, Wien & Olmütz* 1858, 60-61; Kayser, 1908, 873; Harvey, 1957, 402-403.

solution. Pierre used Stokes' idea of exploring the spectrum of luminescence to determine the chemical composition of matter.³⁵¹⁴ In 1862 he discussed the use of fluorescence phenomena for the detection of fluorescent substances in mixtures at the journal of the Royal Bohemian Society of Sciences and in 1866 he wrote about the heat radiation caused by fluorescence at the Viennese academic journal which was republished in Poggendorff's *Annalen der Physik und Chemie*. In 1884, soon after Stefan's heading of Viennese exhibition, Pierre established his own chair for electrical engineering at the Viennese College of Technology (today's University of Technology) and applied for the establishment of a laboratory based on the model of Germany's first electrotechnical chair of Stefan's deputy at the Viennese exhibition Erasmus Kittler at the Technical University in Darmstadt in Hesse.

After the March revolution of 1848 Pierre worked as substitute teacher (supplent) for physics and adjunct teaching mathematics and physics in Robida's Klagenfurt. Pierre was professor of physics at the Technical Academy in Lvov in 1851 and then full professor at the University of Lvov in 1853-1857 as predecessor of Radziszewski. In Klagenfurt, Karl Robida began his lecturing of mathematic and physics as the collaborator of his decade and a half younger but formally better educated Pierre during the Spring of Nations. In 1861, J. Stefan's grammar school professor Robida listed "fluorescence phenomena among the natural colors of the reflected light of the body." He agreed with Stokes that during the fluorescence "the oscillatory period" of the emitted rays is increased, which is equivalent to increasing the oscillation amplitude due to weakening forces between molecules of fluorescence material. He illustrated the "Fluorescence Reflection" of molecular and intermolecular dual layers on the surface of the prism with a sketch.³⁵¹⁵ Thus, Robida first wrote about Stokes' law in the Slovene national space to support his theory of the same volumes of (point) atoms with masses dependent

³⁵¹⁴ Victor Pierre (1819-1886), professor of physics at Prague, later at Viennese Polytechnic, *Über die durch Fluorescenz hervorgerufene Wärmestrahlung*, Wien.Ber. 53 (1866) 339; Pierre, *Beiträge zur genaueren Kenntniß der Gesetze der Fluorescenz-Erscheinungen*, Wien.Ber. 53 (1866) 707-709; Lommel, 1871, 44; Kayser, 1908, 877; Harvey, 1957, 401.

³⁵¹⁵ Robida, 1861, 38-39, illustration 9.

on the properties of a substance, which is unacceptable today.

The Viennese high school professor Moravian Franz Josef Pisko also described his own observations of thirty luminophores illuminated by different vivid colors in 1861. He accepted Stokes' theory, although he also described Eisenlohr's ideas. In his closing chapter, he described the use of a fluorescence for the determination of the ultraviolet component in different spectra. They should not be permitted in a photographic darkroom, since fluorescence rays are also photochemically active. He noticed that the fluorescent invisible script made by the quinine or the aesculin solution could be photographed through uranium glass in the microscope to avoid strong blue-sky light.³⁵¹⁶ His uraninite (pitchblende) was extracted from the Habsburg silver mines in Joachimsthal (Jáchymov) for a colouring agent in the local glassmaking industry. Ettingshausen's student Pisko was a great historian of thermodynamics and optics as well as editor of final third edition of F. Hessler's textbook of technical physics published in 1866 which made his popularizations widespread in Habsburgian monarchy. Pisko served as professor of physics at the Viennese technical military academy in 1870-1872 and finally as a high school director even if Habsburgian regular curricula never fully adopted luminescence again after the Jesuits Biwald, Schöttl and Herbert's *Dissertatio de igne* of 1773.

At the Yugoslav Academy of Sciences in Zagreb Tesla's teacher Sekulić announced that the frequency of light cannot change upon its transitions from the ether to the substance, which could only affect the amplitude of light. He did not trust Stokes' law because Sekulić refused ether in general. He observed "calcescence" in glass cathode ray tubes in which he inserted powders of various metals. Sekulić interpreted the phenomenon, like Lommel, by analogy with Helmholtz's combination of tones. In changing frequency of the absorbed light, Sekulić saw an example of more general mutual conversions of light, heat, electricity and magnetism. Sekulić concluded the discussion with an idea in Lommel's style: "The phenomenon of fluorescence and

³⁵¹⁶ Pisko, 1861, 41-45, 100; Harvey, 1957, 408. Robida published first overview of physics in Slovenian language, Pisko published first textbook of physics with Slovenian terminology in otherwise German text .

calcescence can only be created by a combination of two waves of different nature, therefore, with two colors of a different nature."³⁵¹⁷

In 1876/77, Reitlinger and his student turned assistant Alfred knight Urbanitzky (1852 Voitsberg 30 km west of Graz in Styria-1905 Vienna) investigated the green phosphorescence at the cathode-ray tube. They found that an inch broad phosphorescence carries a negative charge and affects the voltage and the current through the cathode-ray tube.³⁵¹⁸ In 1879 Urbanitzky and Reitlinger described the absorption of gas on cathode in fluorescent cathode ray tubes, and also how a green phosphorescence spot formed on the inner wall of the tube approached by conductor from the outside. In 1877 at the Viennese TH Urbanitzky presented a first remote transmission of music using Bell's telephone over a 210 km long telegraph line and received his PhD with a dissertation on the stratification of electric light at the University Tübingen. In 1883 he and J. Stefan co-founded Elektrotechnische Verein in Vienna (today Austrian Association for Electrical Engineering, Österr. Verband für Elektrotechnik). He became a great popularizer and historian of electromagnetic sciences.

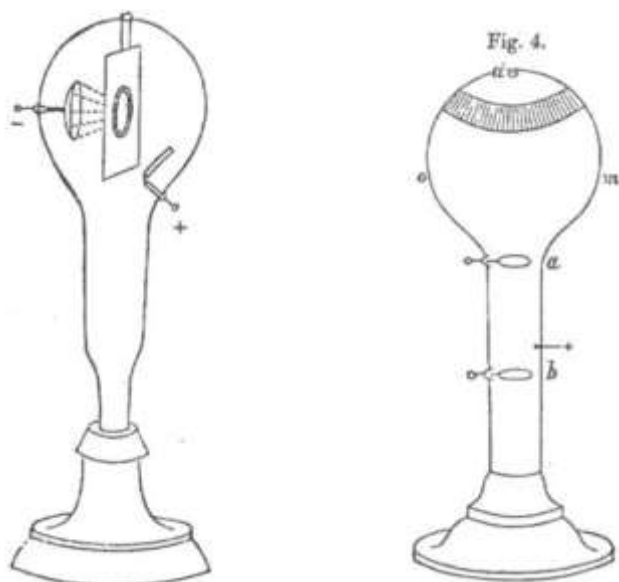

Figure 31-17: Puluj's experimental devices.

³⁵¹⁷ Sekulić, 1871, 83, 86.

³⁵¹⁸ Edmund Reitlinger (1830-1882), Alfred von Urbanitzky from Viennese Polytechnic, Über einige merkwürdige Erscheinungen in Geissler'schen Röhren, Wien.Ber, II 73 (1876) 685-689; Reitlinger, Wien.Ber, II 80 (1879) 665-686; Reitlinger, Wien.Ber, II 82 (1880), 677.

Urbanitzky's seven years older Ukrainian colleague Ivan (Johann) Puluj as the Orthodox theologian turned electrician studied the changing phosphorescence in the overpressure cathode ray tube. He noticed that carbonized paper showed bluish green phosphorescence when bombarded with cathode "rays". The color resembled the diamond's phosphorescence, therefore he repeatedly checked his charcoal under a microscope. Unfortunately, only for similarity.³⁵¹⁹ No diamonds around and Puluj did not become a magnate.

Puluj criticized Goldstein's assumption that phosphorescence does not produce cathode rays, but the accompanying "positive light". He also rejected Crookes' finding of 1879 that the glass wall is "tired of forced phosphorescence", as fluorescence is supposed to reduce sputtering (overlapping) of particles on the glass.³⁵²⁰ Today, we consider (Crookes') aging of the supposedly tired luminophore as well as the (Puluj's) diffusion of ions if metals on it.

31.9 Luminescent Lighting (Electro (Photo) Luminescence)

Puluj made up a radiometer with plates covered with luminescent calcium sulfide. He covered the mica plate shaped as an ellipse with the same luminophore in the cathode-ray tube. The aluminium cathode had the same diameter as the cathode ray tube, while he put much smaller anode above the luminophore: "The light of the phosphorescent lamp is bright enough to illuminate the room and allows reading at a considerable distance." Puluj demonstrated his lamp, which enabled reading at distance of 3 to 4 meters, at an international electric exhibition in Paris in 1881³⁵²¹ together with the designs of Urbanitzky, Ernst Mach and Jewish student of Prague Polytechnic Josef Kareis (1837 Semice (Semitz) in Bohemia-1913 Vienna). Kareis represented his native Bohemia as secretary of J. Stefan's Internationale Elektrische Ausstellung in Vienna in 1883, became first editor of Viennese Zeitschrift für

³⁵¹⁹ Puluj's measurement tool was pictured by Vakuunist 17/2) (1997) 23.

³⁵²⁰ Puluj, 1889, 245, 248, 257, 259.

³⁵²¹ Lehmann, 1895, 363 (illustration 206).

Elektrotechnik and later excelled as a prominent Viennese municipal politician.

On 13 February 1896, Puluj proved that the fluorescent substance in his lamp did not radiate X-rays like Becquerel's following Poincaré's Parisian suggestions few weeks earlier. Puluj was, of course, not the first European to come to terms with luminescence lighting, as Alexander von Humboldt (1769-1859) in the Caribbean already loved the lighting of his giant fireflies enclosed in glasses. As early as 1860, Gassiot described the use of cathode ray tubes for lighting in the Transactions of the Royal Society in London. In 1882, Rankin Kennedy (1853/54-1917 Isle of Bute) of Glasgow received an English patent for a cathode ray tube with electrodes covered with phosphorescent material, which glowed after bombardment with cathode "rays". Rankin Kennedy later worked under the director of his fellow Scotsman Lord Kelvin in the limited liability company Kelvin and James White Ltd. newly formed in 1900.

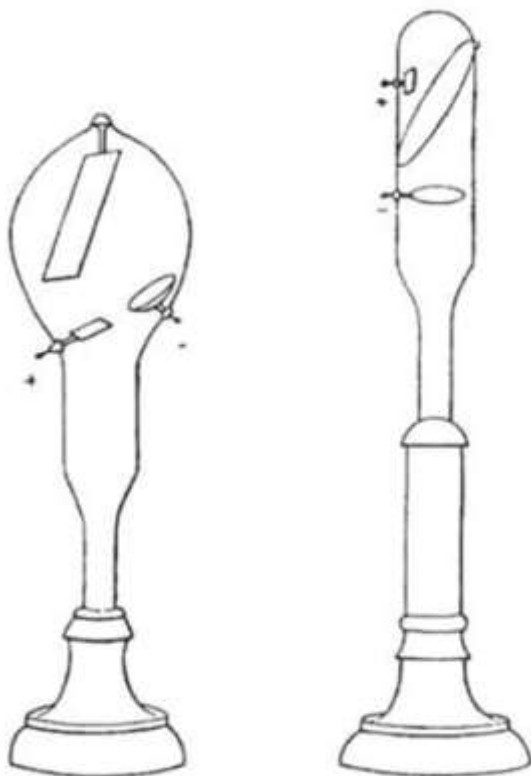

Figure 31-18: The design of Puluj's radiometer.

Despite of USA efforts and needs the decisive discoveries in luminescent lighting were mostly still achieved by the Germans and the French. Pohl used to deal with metal thin-layer mirrors before the First World War in Berlin. Between 1920 and

1923, and in 1929, together with his Göttingen student turned assistant Bernhard Gudden he detected changes in the motion of electrons by the excitation and emission of light from Théodore Sidot's blende invented in France in 1866. Pohl's discovery was contrary to the results of the Lenard's group from Heidelberg. Between 1909 and 1914 Lenard and his guys reported that the conductivity caused by lighting is not related to phosphorescence and that phosphorescence does not affect the conductivity of luminophore.³⁵²² Pohl supposedly disliked Lenard's Nazism while placing his Göttingen students of experimental physics at best German academic chairs resembling Sommerfeld's Munich students of theoretical physics or earlier J. Stefan's Viennese students, but Pohl's student Gudden died as dismissed arrested Prague university professor after lost WW2.

Pohl's research was continued by Frenchman Georges Destriau (1903 Bordeaux-1960 Paris). He examined the suspension of the same Pohl's polycrystalline luminophore in oil in *Centre national de la recherche scientifique* (CNRS) in 1936. It turned out that the most suitable mixture for implementing Destriau's effect is the mixture obtained by glowing 3/4 of available zinc oxide bleach with the other 1/4 of zinc blende with traces of blue vitriol at a temperature of 1200°C. The brightness increases at higher frequencies and voltages, and at higher temperatures.³⁵²³

Geissler's cathode ray tube was offered for lighting shortly after its invention. In 1862 in Great Britain the first patents came out by experts from Birmingham at Warwickshire Timothy Morris and Robert Weare, and by Edward Henry Cradock Monckton from Fineshade at Northamptonshire. In 1860 in the *Proceedings of the Royal Society of London*, Faraday's biographer the chemist John Hall Gladstone (1827-1902) described a bulb filled with helium. He used to be Graham and Liebig's student and married the niece of Lord Kelvin which enabled great impact of his suggestions. On 13 May 1859 Gladstone and his fellow commissioners appointed to inquire the Condition and Management of Lights, Buoys and Beacons, viewed the Way's lighters. They merely examined

³⁵²² Gudden, Pohl, 1924, 8; Fritz, 1940, 124; TSidot, 1866, 188; Sidot, 1868, 1257.

³⁵²³ Miroslav Adlešič, Svet svetlobe in barv, MK, Ljubljana 1957, 186.

the professor John Thomas Way's laboratory and house at No. 15, Welbeck street West End central London, but also his designs at Hinde street and the corner of Manchester Square, where his great superiority over gas light was evident. John Thomas Way (1820–1883) was a professor at the Royal Agricultural College at Cirencester and became a Consulting Chemist to the Royal Agricultural Society as an expert for river pollution and soil manuring. Though Humphry Davy demonstrated the possibility of producing light from a discharge in mercury vapour by maintaining an arc between a wire and a pool of mercury as early as 1821, on September 3, 1860 J.T. Way first demonstrated practical lamp by completed installation of modified carbon arc lamps on the Hungerford suspension bridge in London. His arc operated within a glass vessel containing air and a sizeable pool of mercury. The actual point of light generation in the carbon arc was the incandescence of the electrode tips, the arc itself being substantially non-radiative. In J.T. Way's lamp the heat from the discharge caused a small amount of mercury to evaporate, filling the glass chamber with its vapour, which was consequently ionised and imparted its blue-green colouration to the arc while also greatly increasing the total light output from this source. He was duly granted a British and USA patents for this novel extension of carbon arc lighting technology by the method employed for starting the arc in his lamp. With the ordinary carbon arc, the discharge was struck by bringing one of the electrode tips into contact with the other, and then withdrawing it slightly, the arc initiating as soon as contact was broken. This inconvenient method was surpassed in his mercury lamp, in which the upper electrode was fabricated with a small hole running along its length. To strike the arc, part of the mercury was poured through this hollow electrode, falling into contact with the lower electrode and automatically initiating the discharge once the flow finished and contact was broken. The electrodes in the lamp were stationary and as they burned away during use, complex electrical control gear would have been necessary to adjust the electrical supply as the arc gap lengthened. Way's light was produced in a stream of mercury flowing through slender tubes and connected above and below with the poles of a powerful battery. By clockwork, the connection can be broken and remade, and the light extinguished and relit instantaneously. The powerful light of a peculiar ash grey colour, which

gave a ghastly appearance to every person and thing in the room. The health and safety issues associated with such a lamp would be horrendous today, since mercury was freely vaporised and released into the open atmosphere. No other known installations of Way's lamp are known, and in view of its dramatically enhanced performance this seems unusual. It is probable that even in the mid 19th century there were concerns over the possible poisonous side-effects of the lamp he developed as B. Hacquet published about it earlier. Later in 1899 the other Arthur Fitch Way, as collaborator of Franke Stuart Havens who received his PhD at Yale, filled a patent for Kent chemical laboratory at Yale University in New Haven completed by Albert E. Kent's gift in 1888. However, helium was never frequently used in incandescent light bulbs, because it is expensive and better good conductor of heat than most gases, which makes helium filled bulb less efficient.

In 1879, Crookes somewhat disappointed expectations when he proved that under certain pressure the luminosity of cathode ray tube could no longer be used. The cathode ray tube was first commercially employed for lighting on Queen Victoria's diamond anniversary in England in 1897.³⁵²⁴ The use of cathode ray tubes for lighting was limited by their short life.

By his patent granted in 1901 the son of New York mayor Peter Cooper Hewitt (1861 New York-1921 Paris) produced around 100000 Hg lamps 1 m long with a diameter of 2.5 cm. The efficiency surpassed Edison's bulbs but the emitted light was of a bluish-green unpleasant color. In the 1930s at GE a fluorescent coating was added to the inside of the tube for more pleasing white light radiated after it absorbed the ultraviolet light from the mercury. This made the fluorescent lamp one of the most widely used lamps in the modern world.

In 1895 the first usable "neon" lamp was finally demonstrated by former Edison employee Daniel McFarlan Moore (1869 Pennsylvania-1936 New Jersey), who solved the problem of short life with a valve that admitted the air into the tube when the pressure in it fell excessively. Moore's neon lamp had a length of 7-9 feet with a diameter of 2-2.5 inches and could use other gases. At first, he worked for US GE, and then he set up his own company. After Moore left United Edison

³⁵²⁴ Bowers, 1998, 115-119.

Manufacturing Company his lamp became the first commercially viable light-source based on gas discharges instead of incandescence. He used the USA standard voltage of 110 V for his 2.5 to 3 m long tubes.³⁵²⁵ He arranged cathode ray tubes and neon lamps for illumination at the beginning of 20th century. But lighting was dangerous as the unemployed inventor became enraged after finding his invention which he filed for was already the subject of a patent granted to Moore. And the bullet was ready for poor old Moore there in wild west.

The French chemist Georges Claude (1870 Paris-1960 Paris) developed the industrial liquefaction of air and commercialized Moore's neon lighting as a supporter of Jacques-Arsène d'Arsonval's ideas of generating energy by pumping cold seawater up from the depths for ocean thermal energy conversion (OTEC) in Cuba in 1930 shortly before N. Tesla discussed OTEC in December 1931. In 1910, Georges Claude presented a neon tube in the Grand Palais in Paris and in the church of Rouen. The "Neon lamp" needed high voltage and expensive and complicated installation, but it worked well and gave a better light compared to the bulbs which used the tungsten filaments. In the 1930s, Claude dyed the interior of the luminescent bulbs with enriched fluorescent color. He developed a technique for liquefaction of air and separation of its constituents, among them noble gases needed for his bulbs. In 1902 he founded Société l'Air Liquide. In 1925 he was joined by his younger brother André († 1955), the graduate of École de Physique et Chemie Industrielle. They founded Société Claude Lumière, which joined Paz & Silva in 1935.³⁵²⁶ But Moore's neon lighting did not end well even for the royalist Claude because of his collaborations with Nazis' Vichy regime.

The couple Curie's industrialist-chemist partner Emile Armet de Lisle (1853–1928) launched first radium factory in the world Parisian Société anonyme (S.A.) Françaises dite Banque du Radium. In 1910 in Belgium his factory patented luminescent sulfides, which illuminated upon radiating by radium in the vacuum.³⁵²⁷ One of his best assignees was the inventor Alfred Neveu. In 1904, Armet de Lisle began financing the French

journal *Le Radium* resembling Edison's Science in the USA.

However, luminescence lamps began to be widely used only after Arthur Holly Compton's successful experiments with fluorescent lighting at General Electric Co., Ltd. in Great Britain in 1934. Several weeks later the pacifist George Elmer Inman's (1895 Kenosha, Wisconsin-1972) team at General Electric's Nela Park (Ohio) engineering designed laboratory prototype of fluorescent lamp. They applied for a patent in the US in 1936 which was granted only during the war in 1941.

The other triumph of lighting with cathode-ray lamps began after the use of fluorescence coats. In 1859 E. Becquerel first used them at a pressure of 1-2 mm Hg in the cathode-ray tube. In 1896, Edison himself filed a patent for a fluorescent lamp which he got approved in 1907. In it, "cathode rays" arose the fluorescence of calcium tungsten, which gave light like a sun. In 1902 Steinmetz made a fluorescent lamp, but he did not have much success with it. In 1906, German engineer Richard Küch of Heraeus' firm used the molten SiO₂ and developed a lamp that worked at higher pressures and temperatures than the ordinary glass bulbs.³⁵²⁸ The GTE Sylvania began researching the fluorescent lamp in Massachusetts and Pennsylvania in 1921 and then started to sell them in the form of long tubes nicknamed "neon lamps". As a rival to GE, although under the GE license the GTE Sylvania continued to produce bulbs.

Prior to the middle of the twentieth century, it became clear that the fluorescent lamp had a lower consumption of energy at the same luminous intensity compared to the ordinary incandescent light bulb. It functions longer and, with the choice of the fluorescence coating around the cathode ray tube, offers a much wider range of possible colors than the bulb, which is eventually cheaper.³⁵²⁹ By assuming a shape like a bulb, just as centuries ago the bulb assumed a shape like a gas lamp, the "energy-saving" lamp might be predicting the final discharge of the good old Edison's bulb sometimes soon. However, we can only use the predictions like those of liquid crystal displays scheduled to replace cathode ray tubes. The Edison's bulbs and Braun's cathode ray tubes were on maybe still are

³⁵²⁵ Bright, 1949, 219-223.

³⁵²⁶ Asimov, 1975, 552; Bowers, 1998, 119.

³⁵²⁷ Harvey, 1957, 304, 413; Puluj, 1889, 291, 293 and 1896, 231; Fritz, 1940, 141, 211.

³⁵²⁸ Bowers, 1998, 176-177.

³⁵²⁹ Bright, 1949, 369, 383-384, 391-395, 437.

among the longest serving technical-industrial tools.

The next success was only the GTE Sylvania's first light emitting diodes patented in the United States in 1948. The research of electroluminescence as a light source was limited after the conclusion that it cannot exceed the "lifetime" of five hundred hours. Since the 1960s, similar technology has been developed for use in flat displays of laptops.³⁵³⁰

31.10 Conclusion

We have read one of the first descriptions of "fluorescence" and "lighting or phosphorescence" in the Slovenian language of Tušek who taught in Croatia: "...the most famous are the so-called light stones, which, after shortly put in the sun, shine in the dark in various kinds of colors. Those stones are artificially made by the connection of the sulfur, phosphorus, arsenic with lime, barite or strontium."³⁵³¹ A century later, Slovenians developed their own laboratory for the research of cathodoluminescent substances for the screens of miniature cathode ray tubes labelled as MKEM in V. Nemanič's vacuum lab of IEVT.

The modern physics was based on luminescent observations. The modern entertainment and computer industry is in its many aspects the observation of luminophores, since "one picture is worth a thousand words",³⁵³² as equivalent to a Chinese proverb "Seeing once is better than hearing a hundred times (百闻不如一见, bǎi wén bù rú yī jiàn)". As most luminescent and vacuum techniques, even that one originated in Far East. But the Westerners were able borrowers anyway. The Easterners and Native Americans always knew luminescence and other eternal truths, while we the white Westerners just loved to borrow their knowhow to prove its obviousness by their experiments, now for one and next time for its

³⁵³⁰ P. D. Rack, A. Naman, P. H. Holloway, S-S. Sun and R. T. Tuenge, Materials Used in Electroluminescent Displays, MRS bulletin (March 1996) 50 (published by the Materials Research Society in partnership with Cambridge University Press).

³⁵³¹ Tušek, 1869, 153.

³⁵³² By the advertise of British TV receiver of the superintendent of the Cavendish Laboratory workshop William George Pye's (* 1869 Battersea, London) Pye & Co. Ltd. of Cambridge in 1939: "A picture is better than a thousand words" (Geddes, & Bussey, 1986, 16).

opposite theoretical direction, and to turn all that into the aggressive profitable technological business.

V. Finale: Organizing Vacuum Researchers & Backfired Philosophical Issues

32 Expert Societies for Expert Firms – and Vice Versa

32.1 Early European Vacuum Technology Companies

32.1.1 *Introduction*

The luminescence and advanced vacuum techniques soon needed businesses and organized focused research groups. The Americans might have been the first in moneymaking, but their European counterparts soon followed while their military humiliated Russian and Chinese by Crimean and Opium wars. Immediately after the Spring of Nations of 1848, two large Central European vacuum companies from the Leybold and Heraeus's families emerged as mushrooms after rain. Of course, the story is well known, and we will mainly summarize and beautify it here. A few people know that only a few years before those, one of the greatest physicists and mathematicians in that period was still close to Slovenian-Italian border in Gorizia to design the theory of vacuum, ether and optics of thin metal layers, which soon came to the headquarters of Leybold and Heraeus. Here is our story about the future baron the erudite Cauchy and about the popping of vacuum firms around his excellent theoretical studies ...

32.1.2 *Heraeus*

On April 1st, 1851, but without the fool's day first April joke, Wilhelm Carl Heraeus (* 6. 3. 1827 Hanau; † 1904) took over his father's company

"Zum weissen Einhorn" in the town of Hanau in the state of Hesse, east of Frankfurt am Main. Their pharmacy has supplied Hanau citizens with necessary and less urgent medicines since 4 April 1660, all the time owned by the Heraeus' family. The town of Hanau as the home of the Lutheran storytellers the brothers Jacob Grimm (1785–1863) and Wilhelm Grimm (1786–1859) developed another dreamy story, this time based on the local smithery traditions of immigrant Protestant Calvinistic tradesman of French Huguenot and Netherland Walloon origin.

Young Wilhelm worked hard and soon his pharmaceutical and chemical preparations and pure rubidium and cesium became famous throughout Europe. He worked closely with local jewelers in Hanau, especially when using relatively new metal called platinum after Hacquet and his peers introduced it to European literati. This metal melts barely at 1769°C. Nobody was able to maintain such high temperatures before Heraeus; so, platinum was hammered while glowing white, which was only the best masters in Paris and London were able to achieve. In 1856, a year before Cauchy's death, Heraeus completely reversed the power ratios, as he succeeded in stacking two kilograms of platinum in the fire of a vapor of oxygen and hydrogen. Thus, Heraeus soon set up jewelry stores, dental products and chemical factories worldwide. The silver smile of platinum artificial teeth became a fashion that massively mutually attracted members of opposite sexes. Soon, Heraeus was among the first to produce pure rubidium and cesium.

Naturally, it was not possible without politics and the rich Wilhelm Carl Heraeus followed the German tradition of Guericke in Magdeburg and Hevelius in Gdansk; he was chosen to be mayor's deputy in Hanau. Of course, this did not make him poorer.

The biggest invention of Heraeus was, of course, their family business. So, Wilhelm Carl Heraeus knew very well how to raise his sons dr. Wilhelm Heraeus (1860 Hanau-1948 Hanau) and Heinrich Heraeus (1861–1910) to enable them to successfully take over his business in 1889, on the centenary of Cauchy's birth. In 1896, a platinum smelting company with forty employees had to move to the outskirts of Hanau because of their rapid growth of production, since each year they

produced about one ton of that precious metal. Heraeus has become the major suppliers of platinum for the first ceramic paints, the electrochemical industry and factories of plastics; before the First World War, Heraeus especially proved himself in catalysis for production of nitric acid.



Figure 32-1 Portrait of Wilhelm Carl Heraeus (* 6. 3. 1827 Hanau; † 1904 Hanau)

The student of chemistry in Göttingen and Berlin Dr. Wilhelm Heraeus and Heinrich Heraeus were able to attract their classmate from Hanau Grammar school dr. Richard Küch (1860 Salmünster 40 km northeast of Hanau-1915 Hanau). Richard Küch studied chemistry, mathematics and physics in Marburg and Leipzig. With his inventions and his direct contacts with the world of science, Richard Küch developed a relationship between production and research at the Heraeus' plant. So, he followed Edison's American example. Küch developed the first platinum blast furnace heaters, and in 1889, the process for production of high-purity quartz glass, which became the foundation of the subsidiary of Heraeus Quarzglas GmbH established in 1912. In the 1960s the director of Heraeus Dr. Heinrich Mohn continued Küch's work.

In 1904, Küch discovered a strong greenish light of

mercury vapors in cathode-ray tubes. The most ingenious Germans from Heraeus, with the help of Allgemeine Elektrizitätsgesellschaft, immediately set up the Quarzlampengesellschaft mbH, which produced the original Hanau silicone sunbursts for artificial sunbathing. All the Germans of both sexes who gave something to themselves ceased to crawl along the hills or on Slavic Adriatic seas and by the pleasant light of Küch's inventions appropriated the desired color of their skin faster and less effortlessly. Until Hitler's takeover, there was practically no competitors in this field; Heraeus has remained strong even in the modern market of UV and IR lamps.

Despite his cooking surname Küch has proved himself with many scientific achievements. Richard Küch used platinum and rhodium for thermocouples and thermometers, and thus based the modern prestigious Heraeus measuring technique.

In 1913, Rohn was a head or research labs of the Heraeus' firm, called Physikalischen Versuchslabors der W. C. Heraeus GmbH in Hanau. Under Nazis' patronage, Rohn was also the member of the Heraeus board of directors and the president of German society for the science of metals (Deutsche Gesellschaft für Metallkunde, DGM) in the Association of German engineers (Verein Deutscher Ingenieur, VDI). In the decade before World War I, Wilhelm Julius Paul Rohn began commercial sales of vacuum smelting in large melting furnaces for Heraeus. In 1913 Heraeus produced the first vacuum alloys. In 1917, Rohn melted nickel alloys with Joule heat and patented the process after a year of testing. In 1921, Heraeus used a low-frequency vacuum furnace with a mass of 300 kg. Three years later, in the impending economic crisis, Rohn described the production of pure chromium by reduction of oxide in hydrogen. In 1928, he used a 4-tonne 350 kW power source for casting 2-ton ingots. He mainly produced thermocouples and alloys for resistant heating.

In 1929, Rohn composed a device for melting large pieces of metal at a pressure of 10 to 50 mm Hg. With additions of iron oxide or chrome ore he reduced the percentage of carbon in molten ferrochrome from 1% to 3% to 0.04%. In the decade before Hitler's takeover of power, Heraeus received a total of eighty-four German and 101

foreign patents by Rohn's and other technological innovations. However, under the Nazis, Heraeus largely sold his vacuum smelters to Siemens, and the rest was sold out in 1948 upon the death of Wilhelm Heraeus (1860 Hanau-1948 Hanau). That vacuum branch of production, unfortunately, was very different from the company's overall orientation.

During the economic crisis after the First World War, the third generation of the Heraeus family took over. In 1925, Dr. Wilhelm Heinrich Heraeus (1900 Hanau-1985 Hanau) made frontlines, and five years later, his cousin Dr. Reinhard Heraeus (1903-1985) also excelled. Between 1927 and 1965 Dr. Wilhelm Heinrich Heraeus was the director of the company, while Dr. Reinhard Heraeus performed the same duties from 1931 to 1970 and took care of technology verification and the use of new physical discoveries for his company. Wilhelm Heinrich Heraeus was clever enough to join the Nazi party already on 1st May 1933. Wilhelm and his wife Else († 1987) founded Wilhelm and Else Heraeus Foundation to promote physics in the country. Under Reinhard's leadership, the company began to develop highly vacuum dispensing technologies in 1930; the first dental compound was produced under the very willing Hitler in 1934. Of course, the price of platinum fluctuated greatly, as the main supplier was a politically unstable Soviet Union under the Stalinist regime. At the beginning of the Second World War, there were already thousand people working for Heraeus; of course, the allies destroyed the production capacity of Heraeus as one of the main backbones of the Nazi regime in 1944 and 1945. The German industrial thinkers did not have any doubts about the choice of their subscribers at all only if they were decent enough to pay.

In the 1950s, Heraeus helped with the production of arcs and cathode-ray tubes with American aid, which typically followed US bombs. This cruel American tactic worked in Italy at the same time, but today we are following it mainly in Iraq; of course, the townsfolk of Dresden or Baghdad do not admire it too much.

Since 1911, Heraeus and Leybold have developed industrial vacuum engineering for themselves. In 1966, they were founded by Heraeus Hochvakuum GmbH and in the following year they finally

merged with Leybold to Leybold-Heraeus GmbH and soon concentrated in vacuum coatings. In 1994, the joint venture was renamed ALD Vacuum Technik GmbH.

Multi-layer coverings were researched in the US and in Europe in 1938. The first technically satisfactory solution was published by a 40-year-old Max Auwärter with a two-layered system in 1949. By the end of the World War Auwärter was famous enough to resign the otherwise promising work at Heraeus on February 22, 1946. By the invitation of the Duke of Liechtenstein Franz Josef II he began to produce rhodium mirrors in the Balzers region based on his patent and research published in 1939. Only God knows what Auwärter, as the former fugitive from Heraeus, was thinking of a vicious circle, after which Balzers joined Heraeus ALD Vacuum Technik GmbH in 1995, as he passed away in that same year. The good old Central Europe did not merge only in Brussels, but at the same time by our a vacuum technique.

In 1983, Dr. Jürgen Heraeus (* 1936) took over the company as the fourth generation of a famous family and turned the company on Asian markets. We are still waiting for the fifth generation as Jürgen produced "only" daughters...

32.1.3 Leybold

On the same time, a similar company grew up On the same time, a similar company grew up besides Heraeus. In 1834 and again in 1846 a young village worker, the Lutheran Ernst Leybold, arrived in the city of Cologne and became a reseller in a well-groomed shop of Martin Kothe († 1851). A cute little man knew how to blur the ladybugs every time when her old lord was not home. After his death, of course, he was happy to cheer up the nice widow Marie born Völker as she might have been exactly six years his older. Already in 1850, the trader with imported wines and pharmaceuticals Ernst Friedrich Leybold (* 7 November 1824 Rothenburg on Tauber; † 10 February 1907 Cologne) founded his own independent company and included in it the production of physical, chemical and pharmaceutical devices in Cologne. Already since 1851, he has made experiments with platinum, like Heraeus. This newly discovered metal offered many promises; even the Ljubljana researcher

Hacquet wrote about it. Leybold ascended to the summit on 30 May 1852, when he met at Cologne his nice hostess Marie Völker (* 1. 11. 1830 Köln; † 14. 10. 1890 Köln). They married soon enough in 1854. The new acquisition of family life has a beneficial reflection of Leybold's fresh corporate direction in the spirit of the boom that followed the spring of the nations in Central Europe in 1848. So far, Leybold has manufactured medical glass and thermometers, but has now decided to expand the activity. Like his rival Heraeus, Leybold has also moved from pharmacy to scientific devices and the use of platinum. In 1866, Leybold bought the Marienburg estate and built a porcelain factory there. A decade after Cauchy's death he set up a glass and mechanical workshop in 1867. This was the beginning of his production of physical devices for science teaching and for laboratories. Cauchy's work in Gorizia brought the best mathematician and physicist from Paris to German-Slavic land, while also the similar flourishing vacuum science came to fruition.

In 1870, Leybold sold its successful and well-established company to Emil Schmidt and Otto Ladendorff, who renamed it into Leybold's Nachfolger. Leybold himself, even before meeting with Abraham, could afford well deserved rest, to which he successfully devoted almost the entire second half of his life. Despite his sale, his company was partly succeeded by his grandson with the same name Ernst Frideric Leybold. By 1931, the company was headed by Emil's son Alfred Schmidt, followed by Alfred's son-in-law dr. Manfred Dunkel until 1967.



Figure 32-2: Portrait of Ernst Frideric of Leybold (* 7 November 1824 Rothenburg on Tauber; † 10 February 1907 Cologne).

The firm Leybold was famous in Cologne for producing radiometers which they sold even to Slovene secondary schools. In 1890, Leybold's Nachfolger introduced a vacuum technique to produce quartz glass. Soon afterwards, the collaboration with Gaede enthroned Leybold's Nachfolger on the Parnassus of vacuum technique tools production.

Soon after the election of Hitler, Leybold developed the first sputtering apparatus for industry. Two decades later, the Slovenians began to use their novelties. In 1957, on the centenary of Cauchy's death, at the first thematic conference by Leybold's premises, an association of manufacturers of vacuum coatings was established, which has thousands members today.

32.2 Vacuum Researchers in "Big Science" of the Second Half of 20th Century

The big firms like Leybold, Balzers, Heraeus, the French Compagnie générale d'électricité (CGE) founded on 1. 4. 1898, and their American competitors soon stimulated the organizations of vacuum researchers. The first monographs of the scientists from pioneering generations published description of early vacuum technology already in the years 1906 to 1926. Nonetheless, only the later vacuum researchers after so many successes began to consider their work as an independent branch of science and one of the foundations of physics. In Slovenian sometimes backward milieu, the vacuum researchers are still mostly classified as the researchers of the new materials, which is not fully adequate. Perhaps a decades long delay in the development of this feeling was due to the commitment to the various branches of learning that form vacuum technology as a concealing common denominator of vacuum research. Thus, in 1939, the descendent of Alsace family which decided to remain in France even after Prussian victory in 1870/71 Ferdinand Holweck (1890 Paris-1941 Paris) was a successful advocate for the establishment of national vacuum societies as former personal assistant to Marie Curie and Paul Langevin. He patented thermionic tubes in 1914 and a decade later he designed a vacuum pump known under his name which utilised the drag of air molecules against a rotating surface to achieve

vacuums with pressures as good as one millionth of a centimetre of mercury. After his collaboration with pilot-writer Antoine count de Saint-Exupéry (1900-1944), the Gestapo freaks killed Holweck. Due to the war, Holweck's initiative had to wait for a Saturday afternoon in November 1944, when the French vacuumists met in the famous Parisian inn near Saint Germain. They were struggling behind their good drops of fine wine, whether to establish a union or rather a scientific society. At the end of the evening, the last opinion prevailed, and on March 19, 1945, nineteen members formed a society named Société Française des Ingénieurs et Techniciens du Vide (SFITV, later renamed as Société Française du Vide, SFV) with the first issue of their Journal *Le Vide* published in December 1945. Later it was renamed to *Vide: Science, Technique et Applications*, while it is published as *La Gazette du Vide* since 2003. In January 1951 it was soon joined by Amsterdam Elsevier Science journal *Vacuum* which published a study about the pioneering Carniolan vacuum researcher Guericke's patron Auersperg in 2016,³⁵³³ two decades after the Eindhoven headquarters of Karl Marx's cousin Phillips moved to 125 km northern Amsterdam in 1997. On April 13, 1962 the Dutch Vacuum Association (NEVAC) was founded to promote the exchange of knowledge in the field of vacuum technology and areas in which vacuum plays a major role as the part of the International Union for Vacuum Science, Technique, and Applications (IUVSTA). The NEVAC assembles nearly 300 scientists, technicians and representatives from some 60 companies.

Eight years after the French, their United States liberators founded a similar organization. On 18 June 1953, at the initiative of Frederick A. McNally, fifty-three researchers met in New York and identified the need for an institution to discuss the problems and uses of high vacuum technology. Six days later, the first meeting of the Committee on Vacuum Techniques was organized and formally established in Massachusetts on 19 October 1953. The first national symposium with 295 participants and thirty-five presented papers happened in Asbury Park, New Jersey between 16

and 18 June 1954. The name did not appear to be sufficiently punctured, and in three years later the members voted to change their name to the American Vacuum Society, Inc. (AVS). Between 1964 and 1980, AVS attracted 2000 to 3000 members, and the membership doubled in the early 1990s. In September 1964, AVS established an expert journal, *Journal of Vacuum Science and Technology*, which soon became the main reading of researchers of the vacuums.

On 5. 5. 1958, the Japanese established a vacuum society during their very close contacts with similar organizations in France, the US, West Germany, Sweden, Italy and Belgium. Already in 1948, a member of the French Vacuum Society Robert Champeix planned the International Vacuum Conference for 1949 or 1950, but the proposal fell into the water due to the lack of money. The initiative was taken over by the Belgian section for vacuum technology founded in 1954, which seriously advocated an international vacuum congress in 1956. IOVST was founded at the 1st International Congress on Vacuum Technology (Premier Congrès International pour l'Etude des Techniques du Vide) led by Émile Thomas (2 April 1907 Brussels-14 January 2001) in Namur in Belgium 50 southeast of Brussels on June 13, 1958. This was the first major international meeting of 522 vacuumists from twenty-six countries associated with the simultaneous world exhibition in Brussels. Émile Thomas became the president of International Organisation for Vacuum Science, Techniques and Applications (IOVST, later renamed IUVSTA) to serve at that post until 1962. France Lah (30th May 1923 Prvenci 5 km east of Ptuj-25th September 1998 Ljubljana) and his two then young collaborators of IEVT participated in the congress in Namur. When the Slovenians heard about it, within a few months they established their own Slovenian vacuum technique section of Electrotechnical society (EDS) a predecessor of the Society for Vacuum Technique of Slovenia (DVTS). Initially it used to be a vacuum technique section at the Electrotechnical Society of Slovenia as most of members participated in both.

On December 8, 1962 in Brussels IOVST was renamed IUVSTA (International union of vacuum science, technique and application) when it became an international association of state vacuum organizations with ten founding members based in

³⁵³³ Južnič, 2016 November. Four centuries of Slovenian Vacuum Techniques from Auersperg-Guericke's experiment (1657) to Tesla's Maribor (1878/1879) (on 400th anniversary of birth of the Prince Johann Weikhard Auersperg (1615-1677)), *Vacuum* 136 (2017) 60-63.

Brussels. The founder of American Vacuum Society (AVS) in 1953 Medard W. Welch (D. 1980) became its new president serving until 1965. In the mid-1960s, many countries already had professional vacuum societies or national committees dedicated to vacuum. On the autumn day on 20-22 October 1960, the Slovenian vacuum technique section of Electrotechnical society (EDS) under Dušan Lasič's supervision organized the first Yugoslavian meeting about vacuum technique with over hundred participants who read forty-eight expert reports to establish Yugoslavian center for vacuum technique (JCVT) with its seat in Ljubljana, transformed into Yugoslavian committee for vacuum technique (JUVAK) on January 26, 1963. On 29th October 1979 it was renamed into the Union of vacuum societies of Yugoslavia under the presidency of Jože Gasperič still with its old popular name JUVAK. That was a great beginning of future successes. On 16th October 1972 the Slovenian vacuum technique section of Electrotechnical society (EDS) became an independent society inside EDS. On 22. 1. 1977 it got a present name Society for Vacuum Technique of Slovenia (DVTS) which was formally registered next year on 29th September 1978.

On 29th September 1981 Society for Vacuum Technique of Slovenia (DVTS) began to publish its journal "Vakuumist" which gradually became an expert journal under the editorship of Andrej Pregelj, Peter Panjan, Miha Čekada and Janez Kovač. As the editorial board member Jože Gasperič stated in his 1999 Vakuumist paper and on 2016 meeting of the editing board, the journal is that basic glue which keeps the society afloat.

Organizations of vacuumists are professional societies; they help to overcome restructuring problems when new areas of vacuum technology are opened. Of course, the organization cannot influence the limitations imposed by nature itself, but it must support the promising solutions.

33 Vacuum Questions Philosophers & Theologians

33.1 Vacuum Philosophy

After the Spring of Nations, the newly invented vacuum cathode ray tube first proved the electrons, atoms and their nuclei much closer to the thinking of physicists and chemists, and only afterwards opened the door to biological entities like viruses, which had yet to be brought to a convenient crystalline form. Even though the most obnoxious virus of the day was the evil causative agent of the Spanish flu, which, despite of its killing of the Spanish king, did not transmit so much in neutral Spain as among the warring parties of WW1. The experts were mainly studying the TMV virus, which was most at hand and it peacefully refused to attack animals or humans.

The virus had successfully evaded the Dutch microscopes of the days of Galileo and Leeuwenhoek because of their poor resolution despite of the professional instrument maker Baruch Spinoza's polished lenses. The problem was finally resolved by the newly designed fertile cathode ray tubes: first by a much more distinct X-rays beam imaging of the son of Dutch mother Roentgen, and then, after World War I, by even more powerful electron microscope. In that way, the modern problems with viruses influenced the philosophical ideas of smallest entities with vacuum included.

33.2 Slovenian Philosophical Minded Physics about Vacuum³⁵³⁴

33.2.1 Sašo Dolenc as Physicist- Philosopher

The vacuum firms and societies smoothed the technological advance, which gradually returned the research of vacuum to its basic puzzles: what is missing in vacuum, could we achieve something like total vacuum? Even for Slovenes the vacuum

is no longer just a technical tool, but also the subject of profound reflection. Dolenc's book saw the light of the world as result of the research, which was financially supported by the ARRS. It is one of the first high-profile Slovenian interdisciplinary research, which itself promises new times. On the one hand, it united the efforts of the Slovene thinkers of the empty with the Russian and the Western research. Above all, it allowed physicists to socialize with philosophers, such as Sašo Dolenc or Miha Nemevšek from SISSA (Trieste) and IJS department F1.

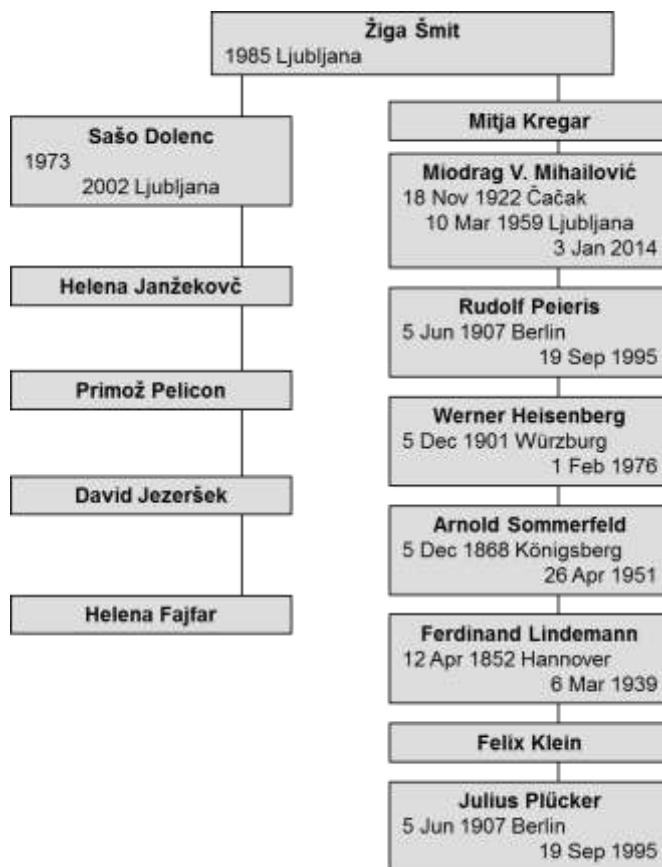

Figure 33-1: Academic ancestors of Sašo Dolenc by his physics graduation thesis awarded by grant of Prešeren

Miha Nemevšek described a vacuum in quantum field theory as a state with the least possible particle-free energy, with a spin that is not zero. He was interested in the possibility of measuring a strong neutrino signal in the Large Hadron Collider to determine how heavy and light neutrinos are combined in Higgs vacuum.³⁵³⁵ In doing so, he proceeded from the basis of Paul A. M. Dirac, but he upgraded it with the assumptions of Ettore

³⁵³⁴ Sašo Dolenc (ed.), The Structure of the Void.

³⁵³⁵ Nemevšek, 2013, 94; Nemevšek, 2013, 1.

Majorana (1906-1936) developed just before Majorana's mysterious disappearance in 1937; his neutrino mass matrices were integrated into the minimal left-right symmetry model. Using the Dirac-Yukawa range of neutrons for the Dirac-Yukawa colliders, such as the Large Hadron Collider, shows how a prolonged influences provided by a century old pioneers of quantum mechanics, whose assumptions are worthy of attention even in today's completely changed circumstances.

Similarly as Nemevšek, Sašo Dolenc also mentioned the works of the great joker Richard Feynman, who, in his own way, began to teach everyone. The New Age is supposed to solve the philosophical ignorance of the early quantum mechanics by denying the "Shut up and calculate".³⁵³⁶ Niels Bohr (and, besides him, Werner Heisenberg with their many supporters) believed that people will never be able to understand the internal composition of the atom because of their mental and linguistic limitations.³⁵³⁷ That funny postulate can be seen in a different light in the changed new economic and networking situation. Sašo Dolenc compared the problems of newly discovered irrational numbers faced by Pythagorean reality with the problems of modern perception of reality and vacuum focused with the advent of quantum physics, in which the main problem is no longer a Bohr's human defects, but rather in Heisenberg's uncertainty principle of 1927 which pushed the universe of vacuum and invisible particles into the realm of statistics as an echo of the uncertain world we lived in the times of recession that occurred in 1923 and 1927 just few months before the fatal Great depression. In fact, the main problem became the very area of statistics,³⁵³⁸ also because insecurity of Heisenberg's 1927 times might not be the same feeling which we witness today in globalized world full of oily trade wars and coronaviruses as kinds of organic nanoparticles. In Einstein's sense, God is not a gambler and statistical-quantum mechanics is primarily due to ignorance and not to the objectivity of Heisenberg's principle of indeterminacy (uncertainty).³⁵³⁹ The statistical mechanics won only temporarily by the transformation of the person himself into the

subject of statistics and will fall when a person returns from the object to the subject. Sašo Dolenc received the Prešeren's award for his undergraduate thesis Dual ionization of internal atomic shells by electron collisions in Ljubljana and continued with his philosophical PhD studies about the importance of mathematization of continuum and the scaled measurements of time for the constitution of modern science to become the great editor of leading local popular magazine, albeit just for a short time as the reactionaries accused him of making a new Scientific American our of Proteus. Instead, Sašo Dolenc became the leading local populariser of sciences.

33.2.2 *Structure of the Empty and Detela's Polyphase Cradles*

The uncertain world of emptiness versus the technical reality of vacuum tools in our everyday use is just one aspect of puzzles which we face as the heirs of Bohr's Copenhagen mainstream interpretation of quantum mechanics. The other puzzles focus entropy as the time arrow itself sanctioned with Carnot's principles two centuries ago. Andrej Detela presented his syntropy effect to us the young physicists a long time ago³⁵⁴⁰ in a hand-bound A4-format booklet, which was gently handed over to us by our older colleague Detela. He said what we all felt: the truth is more than precious, only the courage needs to discover it. Even today, I have this book bound in a yellow card in a prominent place in my library.

Detela's di-entropic effect has matured in the meantime and has become syntropy! Andrej Detela built his new book based on many years of cooperation with the leading colleagues of the Vakuunist magazine. Prof. dr. Maja Remškar showed him the images of atoms on the screen of an electron microscope and introduced Andrej to the secrets of nanotubes. Prof. dr. Slavko Amon has often taken time and acquainted Detela with semiconductor structures, so that Detela could calculate the necessary parameters of the experimental nanostructure and other parts of his experimental confirmation proposals,³⁵⁴¹ for the time being only by predicted manufacturers of

³⁵³⁶ Dolenc, 2013, 50.

³⁵³⁷ Dolenc, 2013, 53.

³⁵³⁸ Dolenc, 2013, 58.

³⁵³⁹ Cvelbar, 2013, 185.

³⁵⁴⁰ Detela, Andrej, 1981, *Dimentropni efekt v homogenem magnetnem polju*. Ljubljana: Graduate seminar FNT.

³⁵⁴¹ Detela, 2014, 22.

syntropy. Based on Amon's advice, a model for a syntropic source of energy with a glowing core which transforms the heat energy of surroundings into electricity. Detela called it glowing incandescent (vajkta, vyakti). It should be made from a thin semiconductor plate with nanoelectrodes bound in a three-phase resonator has been developed. With the future development of nanotechnology, according to theoretical calculations, a compact device of a volume one liter and a kilogram mass could supply as much as 1 kW of electrical power.³⁵⁴² At today's level of development, the achievable power is much smaller, yet measurable - certainly a challenge for a courageous vacuumist, who would focus on the experimental check of Detela's plans.

Detela's new models of the new generation of electric vehicles have gained a lot of recognition among the Japanese, although they are not available on the market yet. The Japanese experience could be decisive on the balance that would convince the Slovenian vacuumists to implement Detela's theory. Not without a reason.

One of the most imaginative Detela's proposals for experimental evidence of a violation of the second law of thermodynamics is based on the production of a thin layer of InSb with a thickness that should not deviate from the desired thickness for more than half the grid constant parameter.³⁵⁴³ That is no doubt a serious technological limitation, which, however, accessible the modern vacuum researchers at the IJS and in other laboratories could achieve if the verification of Detela's theories will be promising and the interest will be yielding. Especially because Detela mitigated his problem in the version in which the external magnetic field eliminates the requirement for that extreme accuracy of the manufactured thickness. His novelties were published in English language in 2020.

Of course, this is also a big challenge for modern, fast-moving thin films' techniques. For the verification of the theory, the expensive AFM (atomic force microscopy) technology would not necessarily be needed, which alone would be able to produce individual electrodes in high-power futuristic power plants. This is the extreme example: the width of the electrodes is less than 5

nm in the three-phase version and is a for 50% thinner in the two-phase version. The conductive layer should not be deeper than 1 nm below the surface, which may have been achieved with graphene. Such a layer of few atoms would be covered with a thin layer of dielectrics and covered with nanotubes.³⁵⁴⁴ For the initial verification of the theory, Detela's book also presents a model with electrodes, which are "only" about 100 nm thick. To make such a system today is perfectly possible, while of course, it is still a great bite for a modern vacuum researcher.

In his research, Detela also tackled the history of developments of a never finally proven entropy law. In doing so, he obstructed notably the funny Maxwell's imagination of the demon as an intelligent nanostructure that redirects individual molecules.³⁵⁴⁵ Of course, the idea of the imaginative Scotsman Maxwell's seemed to be a more fortunate joke to his contemporaries than a serious physical experiment, while in the modern nanotechnological operations with individual molecules, this is not necessary the case anymore.

The research of Andrej Detela's syntropy as the natural ability of many complex systems to spontaneously self-organize themselves to an ever-increasing degree of internal ordering in contravention of the entropy law is certainly a kind of heresy for people who are educated in the spirit of the second law of thermodynamics. Thermal fluctuations are not the same as quantum indeterminacy, but some parallels are suggested: In Einstein's sense, God is not a dice gambler and statistical-quantum mechanics is mainly due to ignorance (lack of sufficiently accurate vacuum gauges) and not just the objectivity of Heisenberg's principle of indeterminacy. The statistical mechanics may have won only temporarily because of the transformation of the person himself into the object of statistics and will fall when a person again becomes a subject; we are already witnessing something like that in web communities. With modern nanotechnology, individual atoms/molecules slowly become distinct from one another in a multitude of themselves, just like a modern-day person who no longer wants to be just a figure in statistics.

³⁵⁴² Detela, 2014, 22.

³⁵⁴³ Detela, 2014, 246.

³⁵⁴⁴ Detela, 2014, 265–266.

³⁵⁴⁵ Detela, 2014, 386.

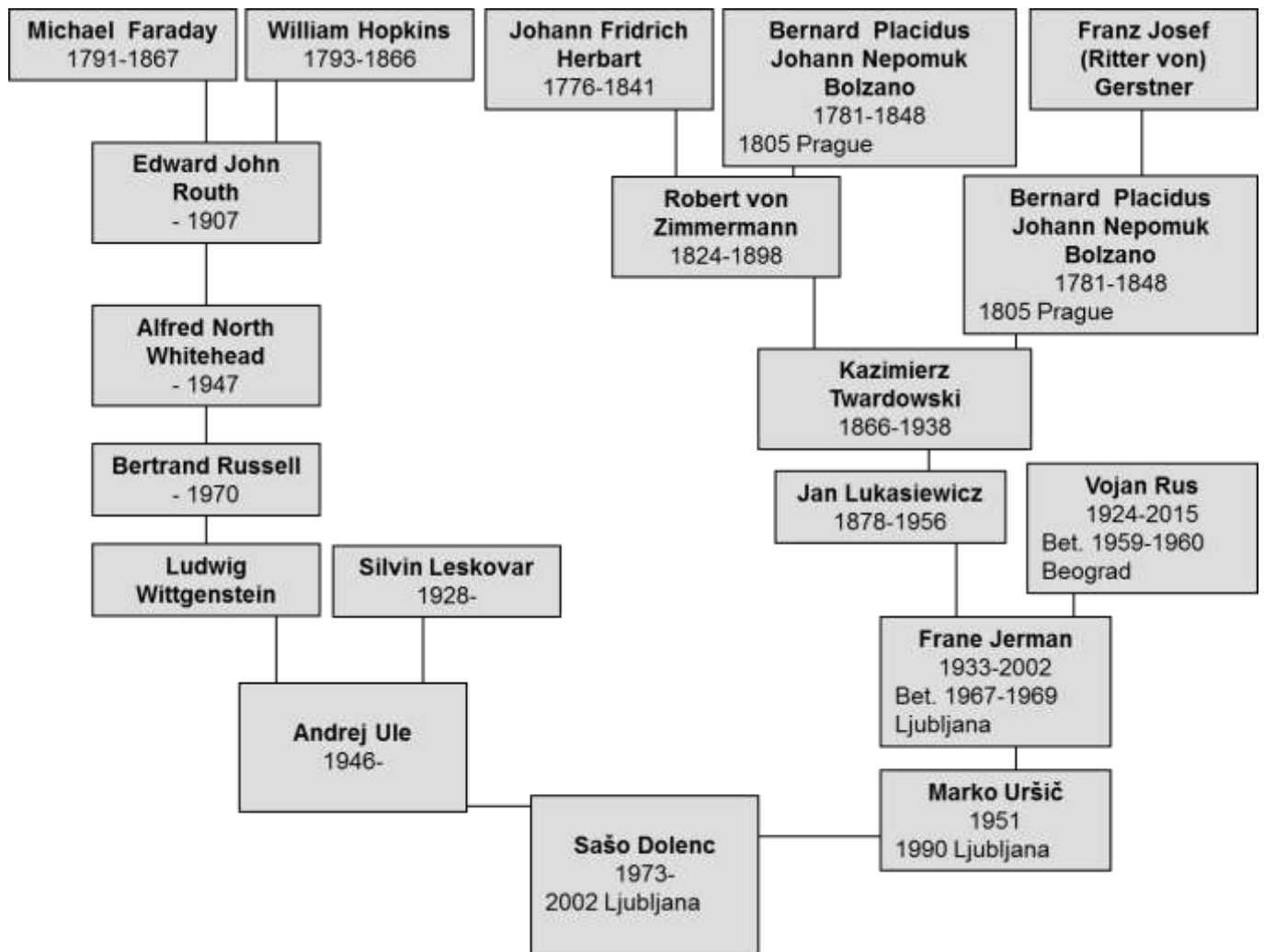

Figure 33-2: Academic ancestors of Sašo Dolenc by his philosophical dissertation

The theoretical background of Detela's novelties can be debated, but the puzzle stands and falls with an experiment. Who among the Slovenian vacuumists will he brave enough to carry it out? Of course, there is a certain risk and deviation from the financially supported ongoing programs, with a small chance that the syntropy will be directly included among them. But courage, both in life and in vacuum technology, always yielded interest. It just needs a little bravery. As Detela loves to narrate his teacher I. Kuščer's expressions of some doubtful aspects of entropy law in his last published paper "Should we believe the entropy law?" Certainly, Émile Amagat's (* 1841) and Jacob Tripler Wainwright's (* 1854) early criticism was misplaced. In their simple cases, the entropy law is nonetheless valid. Namely, entropy is an additive quantity, and if we make up the individual parts of the system, and if these individual parts each separately obey the entropy law, then it also applies to the whole. One should look for a medium that behaves differently at the microscopic

level - e.g. some new physical phenomenon in some strange field, etc. That's no longer a matter of statistical mechanics and conventional thermal processes.

33.3 Development of Vacuum Technology Under the Toynbee-Kuhn-Južnič Scheme

33.3.1 Introduction

Dolenc's and Detela's thoughts about vacuum could be compared with similar approaches of former physicists even if Émile Amagat's and Jacob Tripler Wainwright's (* 1854) early attempts were too simplified. Exploring the empty is as old as the world itself; it's about thinking about the infinitely small and infinitely large, which are at the same time the foundation of an infinitesimal calculus originating in the thoughts of India.

Naturally, the deliberations about the existence of a vacuum in nature were not initially supported by specially convincing experiments.

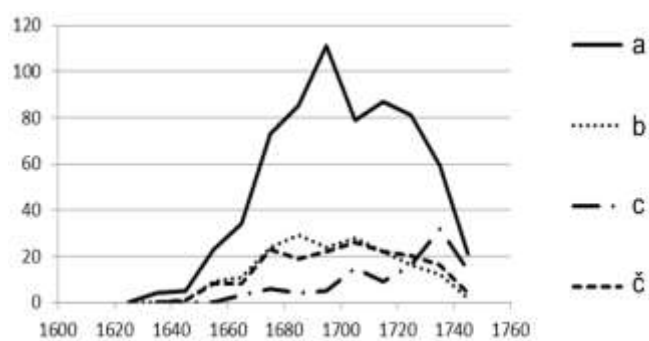

Figure 33-3: The number of Jesuits born in the middle of a decade long interval drawn on a horizontal axis: (a) serving in Ljubljana between 1704 and 1773, (b) taught philosophy in physics in other colleges in a total of 178, (c) they taught or specialized-repeated mathematics in other colleges of a total of 104, (c) the number of writers with preserved works among Ljubljana's Jesuits out of a total of 169

The uniform Ancient European physics was divided into the basic, nowadays classical branches for a relatively long period between 1600 and 1785, between Galileo and the French Revolution. The physiologist turned physicist Hermann von Helmholtz' four branches of physics were adapted to five human senses, which he knew as a physiologist to the last detail: the mechanics for touching with acoustics for hearing, eyesight related to optics, heat of touching again, while the electromagnetism was perhaps much less obviously connected to smell-odour and taste of Galvanic tongue. Before the 20th century, Helmholtz's classical physics was be divided into four branches: mechanics (noted as M), optics (S), electricity-magnetism (EM), as well as research of heat phenomena (T). Helmholtz's distribution resembles the four antique sorts of elements: earth, water, air, and fire. The first three belongs to mechanics and the last one to heat and optics, while the ether could be imagined more electromagnetically. Similarly, six antique arts contained architecture, dance, sculpture, music, painting, and literature. None of them was connected to electromagnetism before the seventh art was invented to endorse photography and/or film. In 1773, with the suppression of the Jesuit society, they also suppressed the formal scholastic teaching of Aristotle's eight books about physics followed by the books *On the Heavens*, *On*

Generation and Corruption, *Meteorology* and *On Soul*.

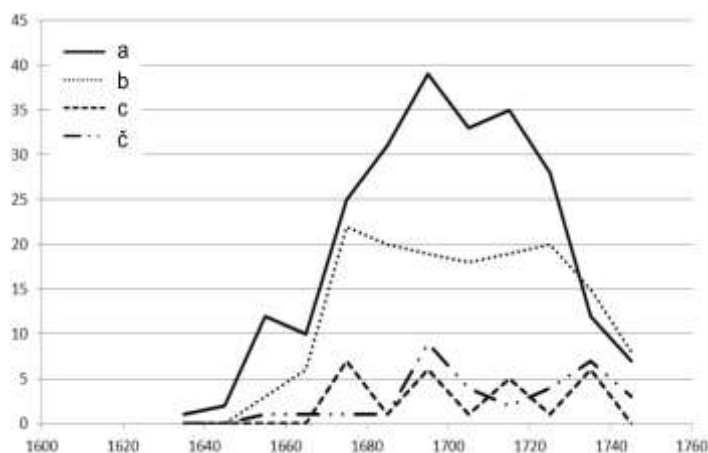

Figure 33-4: The number of former students of the first year of philosophical studies born in a decade long year period, drawn on the horizontal axis: (a) students of philosophy with physics at Graz University of a total of 224 Ljubljana's Jesuits, (b) students of philosophy with physics at the Viennese University among those who served in Ljubljana during the years 1704 and 1773 of a total of 150, (c) students of philosophy with physics at the University of Trnava of those who worked in Ljubljana between 1704 and 1773 out of a total of 27, (č) the professors of philosophy with physics who taught in Ljubljana between 1704 and 1773 out of total of 35

The billionaire turned philosopher Ludwig Wittgenstein's (Vienna-1951 Cambridge) influences his Cambridge fan Stephen Toulmin's (1922 London-2009 Los Angeles) opinion that the finality, in addition to resting as a natural state of Aristotle's science instead of modern dynamics, were Aristotle's medieval advantages and at the same time his Renaissance weaknesses. They became the obstacles to Galileo's change and progress.³⁵⁴⁶ As a scientist, Aristotle retained his prestige primarily in biology, where Charles Darwin respected him; in 1842, Johannes Peter Müller proved the long-overbearing Aristotle's observation of the catsharks.³⁵⁴⁷ Similarly, Kircher's scientific credibility was retained primarily in acoustics. The scholastic and, basically, Kircher's unconventional criticism of the theoretical consequences of the development of vacuum technologies has marked the education of the people of Ljubljana, mainly under the influence

³⁵⁴⁶ Kovačević, 2014, 19; Južnič, 1983, 228, 237.

³⁵⁴⁷ Grant, 2007, 34.

of the Jesuitical University in Graz; the influence of Viennese scholars was considerably lower than Graz's influences as shown in the graphs below.

The Jesuits loved and still love Aristotelian scholastics. Andronicus of Rhodes was supposed to arrange Aristotle's books barely after Christ's death, as Hegel and others reported; although some recommended starting a reading of Aristotle's wisdom with his physics, the influential Andronicus ordered the introductions with logic. Aristotle's physics and metaphysics were banned at the Parisian University in 1210 and 1215; the ban did not affect the apparently uncontrollable Aristotle's logic. Thus, Aristotle's doctrine indeed dominated European thought until Galileo's days for three or at most five centuries; then his ubiquity slowed down also due to Aristotle's rejection of the vacuum, in which the Aristotelian peripatetic bodies were supposed to fall with an impossible infinite speed. The middle eastern Aristotelians had more time as they had no barbarian intermezzo because of Byzantine continuity, but their military performance might not have been European match in 19th century.

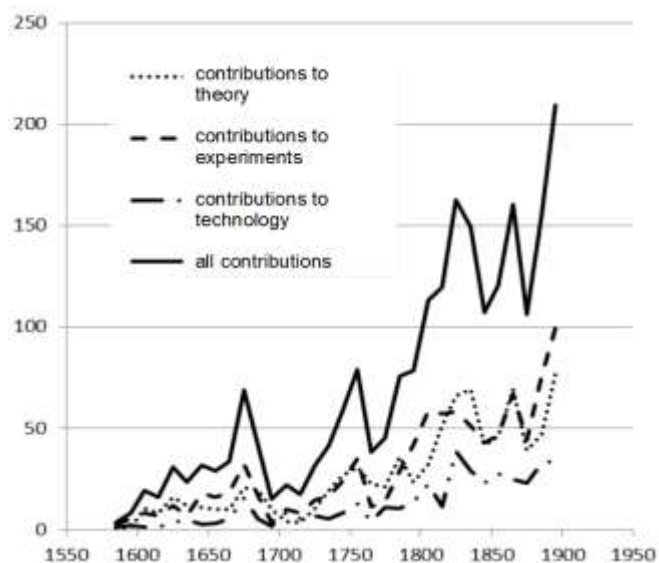

Figure 33-5: The contributions of all physicists according to Asimov (1978), rated from 1 to 9. Vacuum techniques have mainly contributed to experiments, the most perceptible in the middle of the 17th and in the middle of the 18th century, with inventions of the barometer and vacuum pumps or with invention of the Geissler's electrical glow discharges in diluted gases leading to the arc-lamps, X-ray tubes, Braun's cathode ray tubes, Fleming's vacuum tubes etc

Aristotle's prestige was undermined by vacuum technologies as an interdisciplinary research field, born with the barometer of Evangelista Torricelli in Florence almost four centuries ago. According to the division relevant to classical physics, it can be said that barometers and vacuum pumps were initially used in all branches of physics, including the research of mechanics and optics. In the middle of the 19th century, with the Plücker and Geissler inventions of the cathode ray tube for the modern experimentations, the researchers of vacuum specialized in the use of vacuum technologies for the study of electromagnetic and thermal phenomena.³⁵⁴⁸

The vacuum technique obviously advanced all the times to reach ever lower pressures to be distinguished from many other scientific fields, where the direction of any progress cannot be easily determined. The vacuum technology research, like any other, periodically brushed with great inventions, such as a barometer, a vacuum pump, gauges, getters, or a cathode ray tube. Thomas Kuhn might have these events for the revolutions. The invention was followed by a steep increase in research contributions, which was eventually introduced during the expansion into the previously uncovered area of research, such as biology. That could be Kuhn's normal period of research.

Along with the challenges of the new areas, seemingly unsustainable problems were created, which stopped the growth or drove it to the wrong abortive directions. The curve of growth is broken, as we call in physics; its derivative changed the sign. The mainstream researchers of those days did not seem to be alarming, and their investigations continued in the universal paradigm which became relevant for many scientific research fields. However, the disordered clutter disorder of the breakdown had silently aroused and triggered newly developed ideas that competed with the previous basic course of development called mainstream. When different programs were compared and tackled by the prevailing ones, there was a crisis and controversy among important currents that wanted much more money for their expensive research and all kinds of support. A new discovery enabled a breakthrough and triggered a revolution, followed by a new growth.

Thus, each paradigm of the research of vacuum technologies and similar physical investigations

³⁵⁴⁸ Južnič. 2012, 34–39.

with a little effort could be conveniently divided into five states: growth (noted as r), breakdown (z), (disintegrating) universal paradigm (u), crisis (k) and revolution (p); the growth of the first paradigm of a given research branch is its genesis. During the development of the paradigm, the essential working aids are born, which we call universal research methods. The individual paradigms play their role and gradually cease to act as useful research ideas or instruments; that fateful destiny has, for example, seduced the vacuum mercury barometers, which we do not use today in laboratories anymore, and they merely belong to museums because of the poisonous effects of mercury. The universal research methods are in their own way eternal, since they are inherited from the paradigm by its successor; likewise, the universal churches with millions of believers are repeatedly resurrected, despite their seemingly indefinable, occasional crises including the sexual abusers in modern Catholicism or the growing modern scientific atheism. People just need their universal churches and universal scientific research methods as their stones guiding them from personal and professional crisis.

The eastern conceptions of void vacuum and infinitesimals slowly prevailed over European Aristotelianism by growing maritime trades. The ability to develop vacuum technologies was hidden in its extremely rapid initial growth in two experimental directions. The first two crucial experiments, which vacuumists have established on the European scale, have been staged very fast one after the other. First, the Florence Galilean spiritual heirs E. Torricelli and V. Viviani conceived and carried out an experiment with their first barometer. Ten years later Otto Guericke, with the help of Carniolan Prince Janez Vajkard Auersperg, carried out his first public experiments with a vacuum pump. The northern Italian experts, Blaise Pascal with his barometric altitude measurements in France and Guericke with a barometric prediction of the storm in Magdeburg, upgraded the discovery of the barometer. At the same time, Guericke's invention of a vacuum pump was introduced in parallel. The pump has had advantages and disadvantages compared to the barometer: it allowed the installation of the experiment and its actual change in the recipient, but initially did not reach the low pressure of the then barometers. Thus, both groups of researchers swore each to their own seemingly better

experiments. Galileo's heirs, gathered around the Florentine Academia del Cimento, praised their barometers, the "pumpers" collected around Guericke's facilities in central Germany, Boyle's England, and Huygens' circles in Paris and the Netherlands, preferred vacuum pumps. Pumps have gradually turned out to be more convenient and have become commonly used, albeit initially an extremely expensive universal instrument. In England, they were produced for wholesale by Newton's protegee Francis Hauksbee, and soon after the brothers Musschenbroek followed him in the Netherlands. With their production, the paradigm of vacuum pumps entered their universal phase when they were widely used in many scientific branches from biology to electricity also in Ljubljana in the middle of the 18th century; vacuum technicians tried to eliminate as much gas from the exhausted vessel as possible and to prevent leakage from the pumps with a solid piston. From the original 10 mbar they slowly approached the dream value of 1 mbar, but still without special business success or any profitable industrial use. The steam engine, of course, compensated lack of business offered to vacuum tools with its overpressure; however, the steam engines designers nevertheless developed exactly their same vacuum technique in completely new material conditions, full of industrial growth and moneymaking. The evolution of the vacuum technique stopped in the shadow of the steam engine marketing until 1857, when the imaginative Geissler replaced solid pistons with liquid pistons to reach nearly a millionth part of a millibar in the middle of the century during the growth of the new vacuum technology paradigm. In fact, Geissler successfully joined both tradition of European producers of vacuum by mercurial vacuum pump based on moving a column of liquid mercury instead of mechanical pistons, which lowered his absolute pressures of about 0.1 mm Hg based on a new type designed more than 130 years before Geissler's time by the Swedish scientist and theosophist Emanuel Swedenborg's (1688–1772) combination of Torricelli's mercury barometer of nearly a century earlier with von Guericke's pump. In a kind of dialectics frequently propelling the developments of sciences, the thesis of barometer with its antithesis of pump produced Swedenborg's and Geisler's synthesis still in charge today. Certainly, the synthesis needs promotion, therefore in November 1862, the Igelshieb native with some ancestors from the 100 km eastern Habsburgian

Bohemia Geissler joined Plücker on a journey to the Great London Exposition where they presented their experiments to Faraday, Gassiot, the secretary of Royal Institution of London chemist Henry Bence Jones (1813–1873 London), the president of Royal Society Babbage’s antagonist Irish General Sir Edward Sabine (1788 Dublin–1883 London) as worldwide barometric measurer of heights, another Irishman John Tyndall and several others.

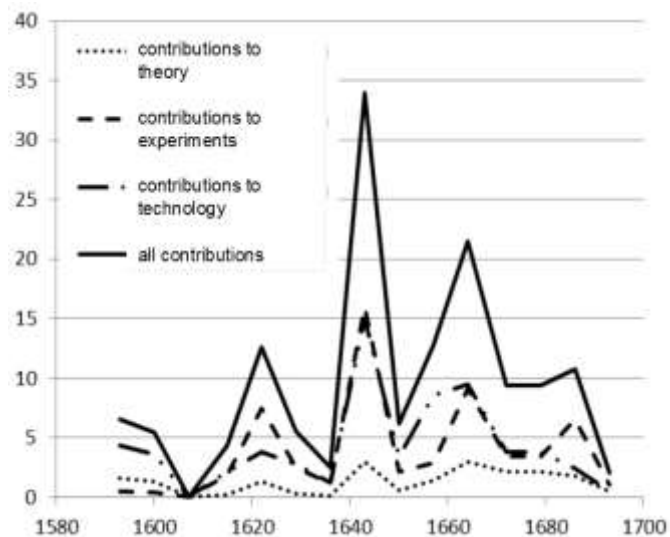

Figure 33-6: Research contributions in Galilean mechanics with vacuum contributions to experiments in the middle of the 17th century and with later technologies of steam engines.

Like once did early vacuum pumps, Geissler's electrical glow discharges in diluted gases leading to the cathode ray tubes have been used to greater extent as the universal instrument of all well-equipped would-be quantum mechanics laboratories. The mercury vacuum barometer was then removed from the laboratories as unscrupulous, according to recent research even a dangerous meter and matter after three and a half centuries of massive usages. The pioneering experiments with barometers and vacuum pumps upgraded by Geissler’s electrical glow discharges in diluted gases for cathode-ray tubes may be the only or at least the most convincing examples in the history of physics of the rare case, in which the contributions of experimental researchers have far exceeded their colleagues of the theoretical fields of research. Something similar much more related to the profitable technology happened to steam engines before Carnot.

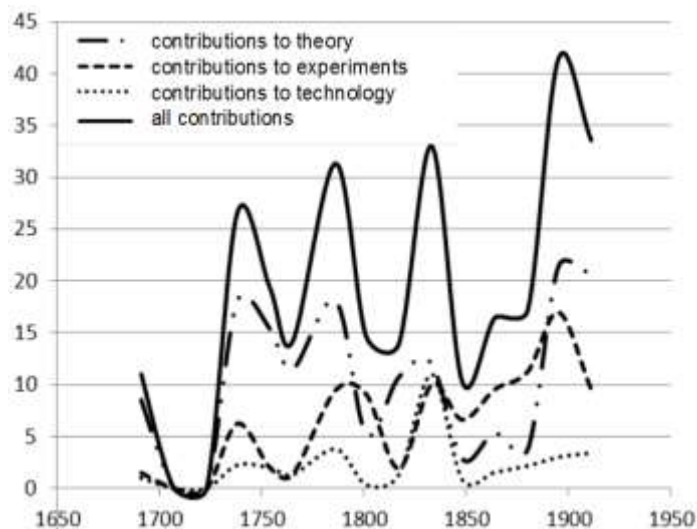

Figure 33-7: Research contributions in Newtonian mechanics

The competitions among the researchers is nicely illustrated with the graphs below. At the end of the 19th century, technological applications even overwhelmed the research contributions of experimental and theoretical scholars. The problems of the development of cathode ray tube vacuum techniques have again increased with the material successes of their industrial use in televisions; at first glance, the successful marketing appears to be welcome, but in real word they have become a goal for themselves and a unique obstacle to further innovation. The new paradigms have exhausted their capabilities during the First World War; 10^{-8} mbar was achieved by new diffusion pumps, and 10^{-14} mbar was made possible by more promising pumps with traps.

In the 21st century we again witness stagnation, and already dubious laboratory attempts to reach the vacuum with lower pressure than that of the interstellar space. The questionnaire returned to its starting point of four centuries ago: Is the (perfect) vacuum possible? What's left in it? What does it contain if there is nothing (material) in it? Is the proximity of absolutely empty a promise of a similarly surprising physical characteristic as the proximity of the absolute temperature zero of Fin de Siècle which the Kamerlingh-Onnes’ superconductivity measurements provided? Probably also resembling the surprising effects of approaching the velocity of light including the twin paradoxes and relativistic length contractions?

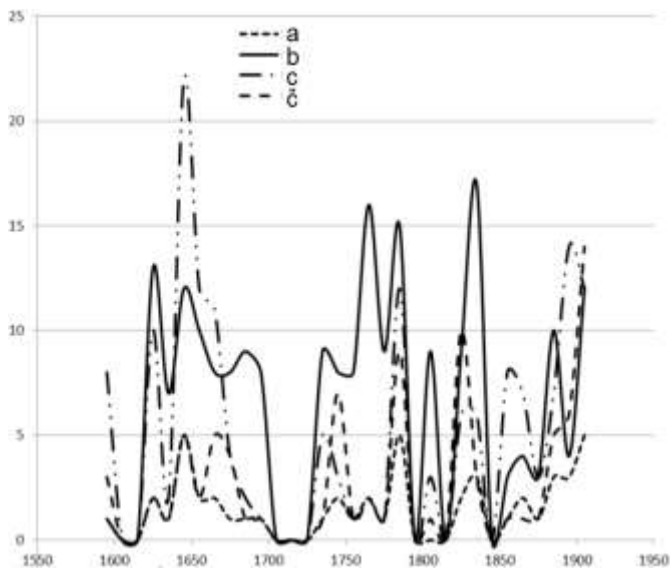

Figure 33-8: Researchers of mechanics designed by the middle date of their work plotted in the decade long intervals: (a) the number of researchers, (b) the contribution of theoreticians, (c) the contribution of experimental work primarily in vacuum technologies, (č) the contribution of technological applications

33.3.2 Cathode Ray Tubes as Historical Case Study

The mixings of experiences from different fields of research likely provides new insights even if it is hard to compare any experimental and theoretical methods with each other, especially in modern physics; the comparison between diametrically different research methods is often abortively poor. On the way to the universal experimental method, vacuum pumps and barometers were, at least in the barometrical networks of Florentine academics, associated with Galileo's research method (A'). They paved the way to Geissler's glow discharge tube filled with dilute gas leading to cathode-ray tube; torsion scales (B2') and electrolysis (F) were similarly important in different fields of research. In fact, physicists have developed many other universal experimental methods that physical paradigms and industries borrowed from each other: in addition to the most important use of vacuum electronic devices including cathode ray tubes in all modern physics and technology (H'), there is also an example of thermal determination of the intensity of electrical current or luminance used in liquid crystal displays, and similar tools combining different traditions of research. John Tyndall in O2r also surpassed the original boundaries with his measurement of the body

temperature according to the color of the emanated light. His results were used by Jožef Stefan by the discovery of his famous law at T2k in 1879.

Despite their great popularity, the vacuum barometer or vacuum pump did not develop into a Pan-European universal research method, although the pump was not far from that by its many designs of burning, ringing, breathing and many other experiments performed in the emptied recipient. A truly universal method, which we inherit even today, has become barely Geissler's glow discharge tube filled with dilute gases emptied by a vacuum pump, and most of all its descendant, a cathode-ray tube; its emptiness was often maintained and even escalated with getters and other additional aids. In our scheme we will label the vacuum with the letter H or H' as the mark for the universal research method of vacuum pumps needed for Geissler's glow discharge tube filled with dilute gases leading to cathode ray tubes. Vacuum experiments and pumps in M1k were the basis for testing steam engines in T1k and T2, and later for cathode ray tubes in electronics (EM3k, EM4r).

The experimental universal methods successively influenced various paradigms. Thus, experiments in the ever-better vacuum of Otto Guericke, following the incentives of the Carniolan Prince Janez Vajkard Auersperg, first made a decisive contribution to the criticism of Aristotle's (M1) and Descartes' mechanics which rejected the vacuum; in fact, an experiment with horses resembling Guericke's ideas was previously conceived by the Parisian professor of theology Jean Buridan (* about 1295; † after 1358), but he used it to discard the existence of an emptiness, which did not please everybody. Nicole Oresme imagined a vacuum as a space between two worlds; both should necessarily be round, so there is some room left between their spheres. The first rector of the University of Vienna (1365), Albert of Saxony, even described cases of supposedly slower falling in the empty space compared to the falling in filled spaces, which today seem to be false. Of course, none of the medieval vacuum-based assumptions could be verified by then available experiment.

Boyle designed his famous law while seeking evidence against the doubters of the existence of a

vacuum.³⁵⁴⁹ The ideas of the early modern sciences of Galileo, Boyle and Newton came to Slovenian countries in books, measuring devices, including proportional heights, in Halley's personal visits and in various Jesuitical events until Bošković, whose vacuum and other modern discoveries were finally sufficiently interwoven with Aristotle's logic. Knowing the properties of low pressures and vacuum helped many British inventors of steam engines in T1 and T2,³⁵⁵⁰ as well as Jurij Vega and researchers of external ballistics in M2. Finally, vacuum of Geissler's glow discharge tube filled with dilute gases leading to the cathode ray tubes developed during the EM3 growth became part of almost all experimental devices of modern physics and industry, except for the later liquid crystal displays. Thus, Torricelli's description of the vacuum in the barometer more than any other invention in history successively influenced the theory, technological application and physical experiments.

Table 33-1: A comparison between the powers of the paradigms grown from the development of vacuum techniques. The letters refer to parts of the paradigms, highlighted in the text above, and the numbers indicate the sequence of the paradigm.

Year	Appearance (technology)	Relative power of opposing paradigms
1644–1654	Barometer, vacuum pump, air pressure	M1u < M1k (Torricelli, Valeriano Magni, Guericke, Pascal and Boyle against Aristotle, Kircher and Descartes)
1918–1931	Television	M3r < EM3p (Zworykin Technology)

The most powerful tools of physics during the Renaissance and quantum mechanics were Galilean thought experiment by neglecting the disturbing effects of friction and of imperfect vacuum (A') and the use of infinitesimal calculus in analytical mechanics (D). According to Chandra Kant Raju (* 1954 Gwalior, Madhya Pradesh in India)³⁵⁵¹ the infinitesimal calculus was transferred

by the Jesuit missionaries under the Portuguese flag from the South Indian area of Kerala to Newton and Leibniz's networks in the second half of the 16th century. Both tools connected with endless, a vacuum and an infinitesimal calculus, are still powerful universal methods even today; they had inappropriately more power than other competitive methods of research. In the genesis of EM3 with Oersted's experiment in 1819, the idea of the law of energy conservation (C1'') dominated the mathematical tools of analytical mechanics (D) under the influence of *Naturphilosophie* of Fichte's student and Hegel's classmate Friedrich Wilhelm Joseph Schelling (* 1775; † 1854).³⁵⁵² In addition to thinking about the existence of a vacuum, this was probably the only direct influence of philosophers on the development of Western modern physics after the Hellenic era, while in India or Far East we could expect more of them. Between 1820 and 1834 Ampère proved the superiority of the universal method D, to which he added the revived Descartes' vortices (B1). Cartesians used them against possibilities of total vacuum once upon time, but new Euler's and Ampère's generations of erudite were able to neutralize or at least ignore that Cartesian mistake. If it was mistake at all since the total vacuum never happened anyway.

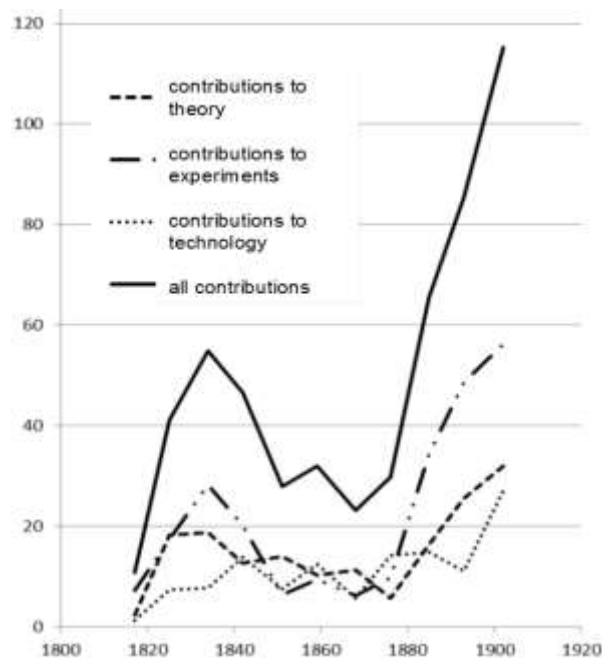

Figure 33-9: Research contributions to field theory (EM3), where vacuum techniques have excelled mainly by experimentations after 1855, and then in many useful technologies

³⁵⁴⁹ Harré, 2002, 11; Grant, 2007, 223–224, 228–229;

Buridan, 1509, 73^v

³⁵⁵⁰ Toynbee, 1976, 565.

³⁵⁵¹ Raju, 2007; Even Žiga Zojs had some books based on fictitious then popular far-eastern Indic wisdom (Svoljšak, Vidmar, 2019, 208-209).

³⁵⁵² Pugač, 2004, 39.

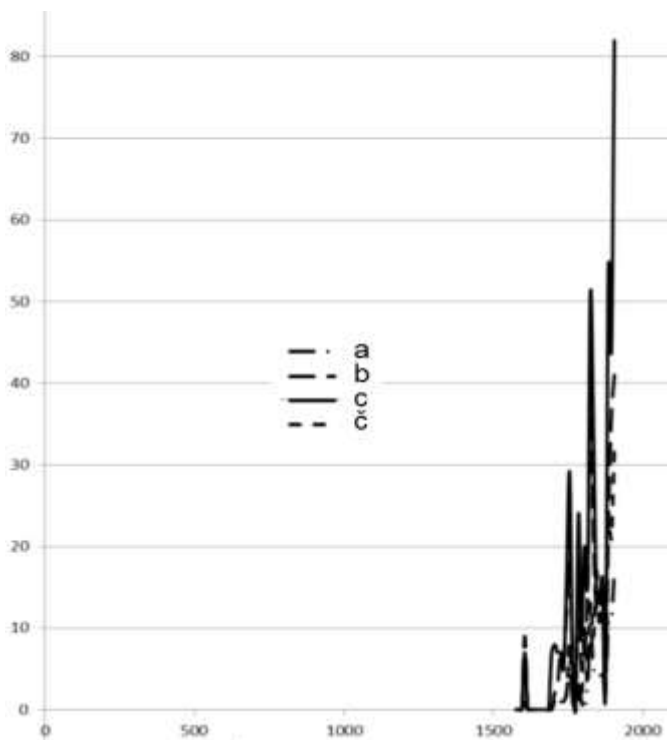

Figure 33-10: The researchers of lectromagnetism at ten-year intervals: (a) number of researchers, (b) theory, (c) experiments with predominant vacuum techniques, (c) vacuum equipment for industry

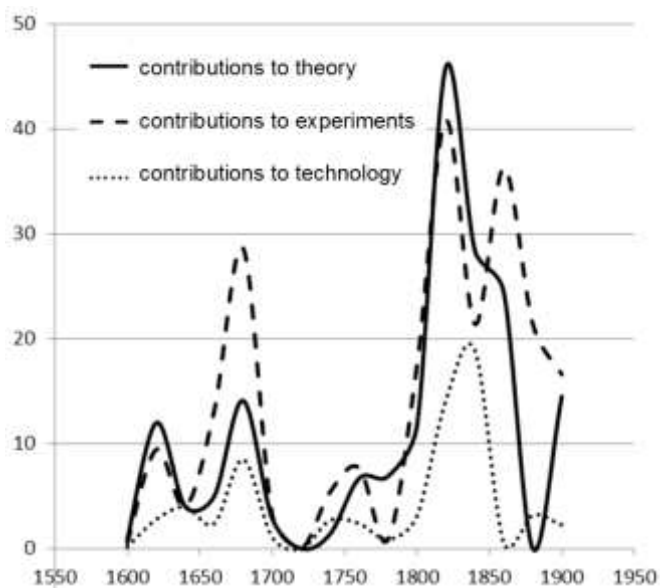

Figure 33-11: Research contributions to optics in total, separated by types of exploration; vacuum techniques have proven to be mainly useful in the field of experiments and technologies in recent years plotted here

Max Planck attributed to Boltzmann's definition of entropy a greater weight than to the universal method of Maxwellian force fields, which contrasted Einstein's conviction. Einstein set Maxwell's force field as the basic element of his

physical description equivalent to matter in Newton's theory. Einstein was so convinced that he even confirmed the previously discarded Descartes's opposition to the vacuum with no Cartesian space that would "be emptied of the entire substance." Naturally, Descartes and his restorer Einstein linked the dimension-space with bodies without which it cannot exist (or at least cannot be perceived), which resembled V. Magni's victimized peripatetic idea. Einstein upgraded the centuries dilemma with the fields converted to masses by his equation $E = mc^2$. There the constant speed of light has become almost the property of the field.³⁵⁵³ The power ratio from Maxwell's times turned around with Planck, which is not surprising. Planck gave to Boltzmann's universal method an advantage over Faraday-Maxwell's universal method, as Planck continued his research exactly where Boltzmann finished it, even if Boltzmann criticized Planck's editorship of the works of dead Kirchhoff. The claim is valid despite Planck's early inclination to Mach's doubt in the existence of atoms that angered Boltzmann. The son of the landowner who breed the Japanese silk moth (*Antheraea jamamai*) at the Lower Carniola (Dolenjska) Gorjanci, Ernst Mach, was a loud provocateur who asked the speakers during the symposium on the atoms: "Did you see them?" Mach diametrically opposed Rutherford's defense of the electrons against Eddington's criticism at the exclamation: Not exist, not exist - why I can see the little beggars there in front of me as plainly as I can see that spoon?!"³⁵⁵⁴ They do not exist? Do not exist? I can clearly see them, just like this spoon in front of you! Such a ridiculous rhetoric of researchers who advanced on the shoulder of each other has more than simply a decisive importance as a source of legendary imaginations that were admired by the young generations of their followers under their umbrella, below the skies of doctored biographies of their glorified predecessors. Similarly, as Mach rejected the invisible cutting of visible particles, the Prussian-Polish Jew, the successful agricultural entrepreneur Leopold Kronecker (* 1823; † 1891) opposed the cutting of whole numbers, striving that all fractional, irrational or even the mystic transfinite numbers were merely a human creation; that Kronecker's opposition also hampered the

³⁵⁵³ Einstein, 2014, 94–95, 98; Balibar, 2014, 208–209, 212.

³⁵⁵⁴ Birks, 1963, 39; Badash, 1987, 354; Reeves, 2008, 82.

adoption of George Cantor's leading theory of infinity in Germany.³⁵⁵⁵

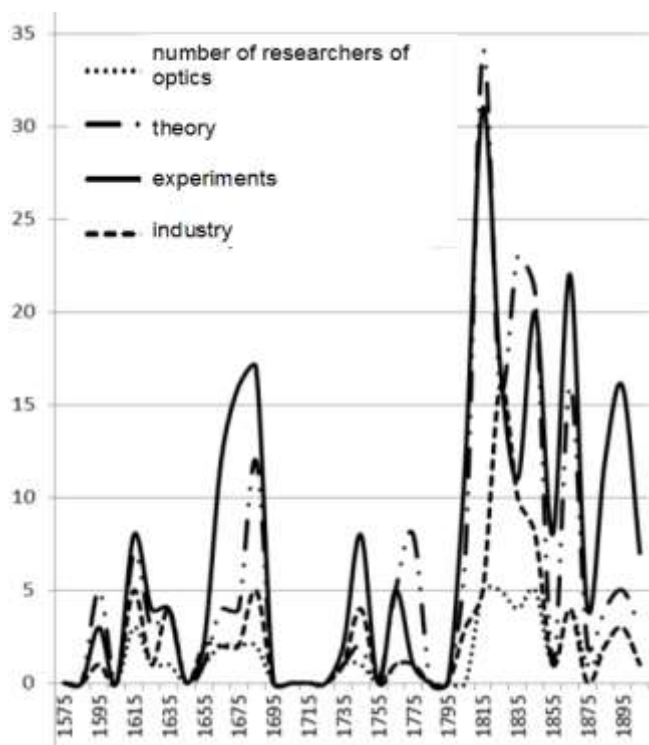

Figure 33-12: A more detailed list of explorers of optics

33.3.3 Vacuum Experiments as a Motor for the Development of Physics and Chemistry in the Era of Crises

The vacuum experiments (H) played an important role in (M1k), in steam engines (T1k, T2) and in cathode ray tube electronics (H') in T3. It is especially worth emphasizing Guericke's vacuum pump (1654) from M1k with experiments set up to answer the doubts of Prince Janez Vajkard Auersperg. It was connected to the contemporaneous Guericke's electrostatic frictional generator turning a sulphur globe by spinning wheel. The fields of infrared (thermal), ultraviolet and visible waves and new rays in vacuum (emptied) tubes were established after 1857. That was one of the pre-paradigmatic environments inherited from M1k, in which quantum mechanics (T3u) developed. New types of rays discovered by experimenting in Geissler's glow discharge tube filled with dilute gases leading to cathode ray tubes did not trigger the growth of the new universal paradigm in quantum electrodynamics EM4r or T3u, although they

³⁵⁵⁵ Reid, 1977, 39, 133; Poliščuk, 1980, 28.

developed experimental methods using vacuum techniques. The universal method of theory remained the statistical theory, inherited from T3r. T1 was determined by vacuum experiments with M1k steam engines during exploration in T1k and T2.

Researchers on both sides of the boundary between the contradictory ideas often use thought experiments to describe the roots of the crisis they are witnessing. These methods are used either because true experiments would be too complex/too expensive, or if their preparation would be too long in time constraints due to the rapidly changing most influential areas of research during the crisis. A thought experiment is a self-exploring method at the boundary between theory and experiment. Its real factual impracticability is due to idealizations such as: neglect of air resistance and friction (Galileo in M1k, (anti)perpetuum mobile in T1k), the unreachable total vacuum (Galileo, Guericke 1654) or the unreachable absolute temperature zero postulated by Nernst. The design of experiments is obstructed by impediments like Einstein's (1905) impossible acceleration to the speed of light, the lack of materials of the required quality, the unrepeatability of homeopathic experiments with the memory of the water of Jacques Benveniste or Luca Montagnier,³⁵⁵⁶ as well as the lack of sufficiently sensitive measuring instruments needed to perform real Maxwell's demon puzzle in T2k. Schrödinger's cat (1935) was a particularly famous thought experiment in quantum mechanics; many others emerged upon exchanged views between the rival Jews Einstein and Bohr at the Solvay Congress in 1926.

Even inside their outdated paradigm, Kircher's Aristotelian Jesuits, Leibniz's followers and Cartesians persisted as opponents of the (total) vacuum inside M1u, Biot and Poisson retained their opposition to Fresnel's transversal light in S1p, Kelvin, Clausius and Simon Šubic doubted Boltzmann's statistic by their obsolete T2p, Einstein fought his opponents in M2p. They and many others were stubborn and conservative because they were committed to the ideals of their youth. The opposition to the vacuum was enhanced by the fierce but abortive rise in research contributions of Kircher and his pupil Linus during half of a century following Torricellian barometer

³⁵⁵⁶ Hadži, 2014, 149.

of 1644; simultaneously the Cartesian denials of absolute vacuum developed their vortex models.

Except for the universal states of development of physical paradigm, the share of technological applications is usually a quarter of the entire research work in physics. It is the highest in explorations of heat, where the experts further tested the operation of steam engines developed by vacuum-like technologies, and later constricted the internal combustion engines. In the second place is electromagnetism, where in the 19th century (EM3) Faraday enabled the use of an electric motor and a dynamo machine. Thomas Alva Edison later patented the vacuum bulb, thus enabling the postponed use of Lambert's known measurements of physiological optics developed for industrial purposes already in a previous century. Although such important technological achievements did not follow the research in optics and mechanics, the share of technological research in optics and mechanics was only slightly smaller.

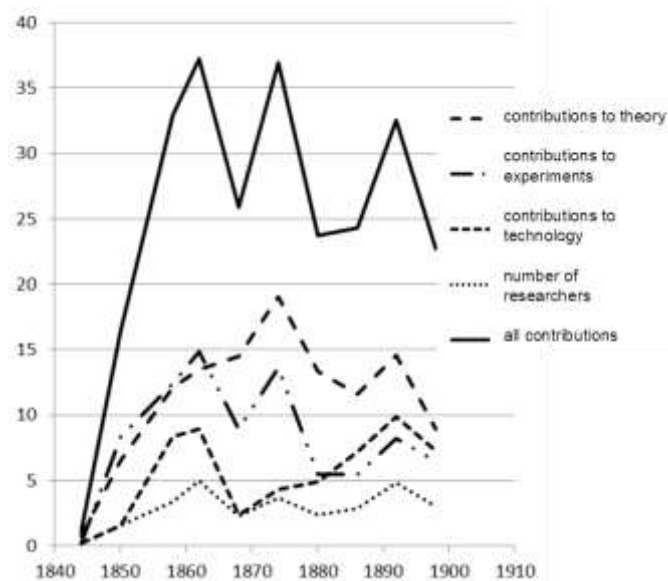

Figure 33-13: Research contributions to the law on the conservation of energy, heat as motion and kinetic theory according to Asimov (1978)

The contributions of individual types of research activities in various branches of physics are changing over time. Between 1841 and 1871, during the spring of nations followed by the wars for unification of Italy and Germany, the share of European experimental research was relatively small, despite the important contribution of Faraday; the share of technological applications was proportionally greater with the most successful

among them such as: vacuum pumps for Geissler cathode ray tubes, dynamo, electric motor, telephone and bulb.

If we draw the number of researchers or their research contributions in mechanics as a function of time, we cannot see the marked maximums at points where they would be expected due to the development of a new paradigm. Four different peaks defined the development of mechanics: the first in the 17th century was neither Galilean nor Newtonian but was due to the relatively large research activity of pioneers of vacuum techniques during their era.

The curve of the development of theoretical research of heat had three maximums. In the first around the year 1680 prevailed the preparadigmatic study of gas laws and the operation of a steam engine developed by the somewhat reversed vacuum techniques. The second peak emerged around 1770 due to the research work of Scotsman Joseph Black, the Frenchmen Lavoisier and Laplace in T1, although Black remained the champion of the phlogiston.³⁵⁵⁷ The study of the law on the conservation of energy in T2 caused up to date last maximum of investigations of heat in 1840 or in 1860.

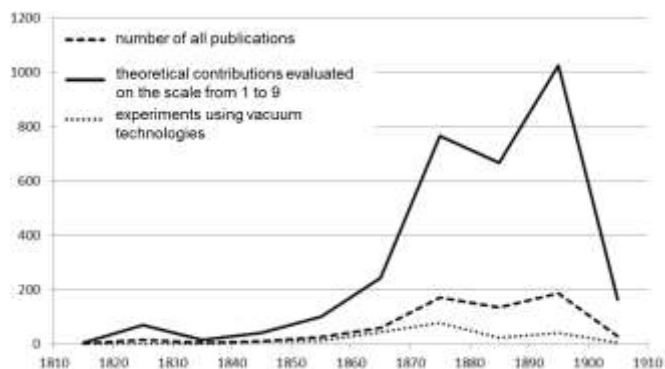

Figure 33-14: Number of publications about heat motion, kinetic theory and statistical mechanics according to S. Brush's census published in 1976

The use of physics in technology and industry has always been a specialty. For example, in his critics of Hobbes,³⁵⁵⁸ Boyle liked to report on the usefulness of the food storage in vacuum, and the mayor of Magdeburg Guericke warned his voters

³⁵⁵⁷ Kuhn, 1996, 70.

³⁵⁵⁸ Kuhn, 2000, 316.

with a barometric forecast of the forthcoming storm. With a great deal of caution, we can, to some extent, distinguish the industrial usability from experimental and theoretical research in physics. In such a simplified model, physical research is limited to experiment and theory, that is, to experiential findings and their abstract mathematical formalism. In the first paradigms of physics, both components of the research were much closer to each other, but eventually the mathematical formalism gradually became more and more abstract.

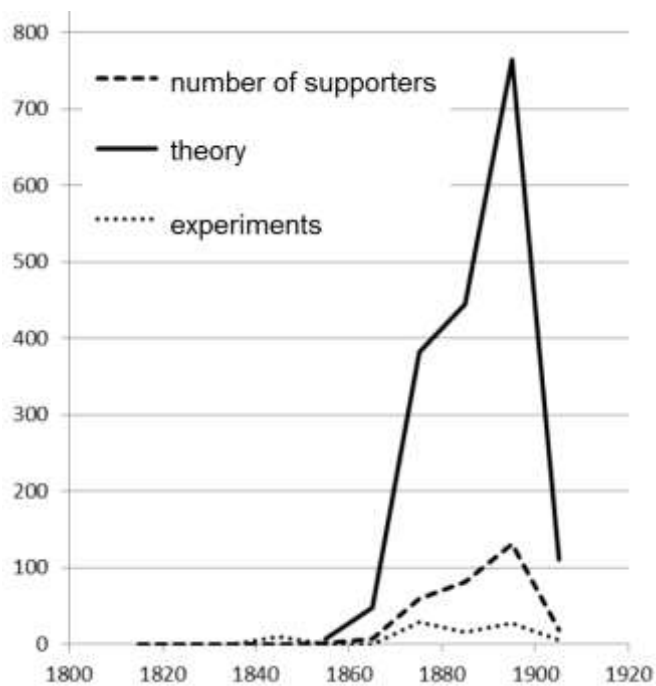

Figure 33-15: Proponents of statistical mechanics

The thought and real experiments in the spirit of Plato and Archimedes were opposed by the scholastic metaphysics of Aristotle's followers. Similarly, the Renaissance mechanics and astronomy of Johannes Kepler (* 1571; † 1630) each offered its own way of exploration. A lot of new discoveries as challenges often forced the old paradigm into a quick search for answers that surpassed its possibilities. The undefined answers therefore often opposed each other; the complexity of the old paradigm grew more rapidly than its accuracy. Soon it became clear that (Aristotle's) physics does not offer the right answers, at least not the ones demanded by developing westerner bourgeoisie. Aristotelianism ceased to be a relevant explanation of physics of Galileo's experimental science. Galileo's fans turned Aristotle's obsolete concepts upside down: Torricelli's vacuum

experiment was explained by air pressure instead of Aristotle's force, which is supposed to drag the mercury up. The generalizations of Boyle, Pascal and Huygens followed the experiments in vacuum of Torricelli-Magni and Guericke-Auersperg.

At the same time, the vacuum became a kind of ether. The breakdown of the second paradigm of optics between 1830 and 1853 has triggered former friends Fizeau's and Foucault's attempt to measure the velocity of light in water compared to the speed of light in air between 1849 and 1853. Already Bošković planned to do it, but upon the spring of nations Arago's suggestion won the day even if he did not like the little Napoleon III so much as Foucault. The association of refractive index with the density of matter became the "experimentum crucis" of Foucault and Fizeau's decision against Newton's corpuscula in favor of Huygens' waves in the middle of the 19th century.

Main problem of Cauchy and others was that the models of the ether should combine the properties of an exceptionally rigid hard solid needed for the spread of transversal waves and the totally empty space for the smooth movement of celestial bodies. During the universalization, the effects of electromagnetism were favoured due to the same velocity of propagation of light and electromagnetic waves in a vacuum. Therefore, the same universal state of paradigm prevailed in S2 as in EM3.

Vacuum experiments with cathode ray tubes became a universal experimental research method, which was also used in the next paradigm called quantum mechanics (EM4). The discovery of electrons and other elements of matter in vacuum experiments produced the basis for new descriptions of the physical world. The electromagnetic field theory, born in EM3z, partly complied with the universal method of S3. In the domain of experimentations, the research involving vacuum prevailed.

33.3.4 Contemporary Orientations in Slovenian Vacuum Technique

The entry of bourgeois sons into European science (1554-1600-1698) was defined by successes of Copernicus, Gilbert, Galilei, Kepler, Kircher, Harvey, Descartes and François Viète; next to

Table 33-2: Correspondence rules of vacuum cathode ray tube electronics that transcend the experiential findings on mathematical formalism and transcends their theoretical interpretation in the opposite direction

Theory	Experimental conclusions	Correspondence rules	(Mathematical) formalism
Braun's cathode-ray tube, 1898	Edison's verification of the most usable lamp fillers, 1878	IV. J. J. Thomson's electrons, 1897	Fields
Geissler's glow discharge tube filled with dilute gases leading to cathode ray tubes, 1857		III Plücker's mathematics and experimental physics of vacuum as the predecessor of spectroscopy	Plücker's analytic and projective geometry as opposed to the Berlin synthetic school of Jacob Steiner
	Boyle against Kircher's Jesuitical rejection of vacuum	II Boyle's skeptical chemistry	Vacuum theory as a mechanical vacuum model
Musschenbroek and 'sGravesande's vacuum pump with a Leyden jar. 1745/46, Hauksbee's pump and friction electricity			
Boyle's translation of the vacuum: 1660			
Guericke's pump 1654 and his friction electricity			Doubts of the prince Auersperg
Barometer of Torricelli-Pascal-Magni, 1644		I Galileo's vacuum	The mathematical language of physics

Table 33-3: Electrostatic correspondence rules

Theory	experiential findings	Correspondence rules	(Mathematical) formalism
	III 1767, Priestley's systematisation	1775, Wilson produces a mathematical theory of conductivity, where the current falls with the square of the length of the conductor	
	1752, Dalibard tests Franklin's Lightning rod in FrancU	II 1750, Franklin's theory of Leyden jar and lightning rod	
	use of electricity in medicine; use of the torsion balance	I Nollet's theory of fluid, which is continuously radiated and re-absorbed by the electrified body, 1746–1749	
	1745–1746 Leyden jar		Aepinus publishes mathematical theory of Beijing electricity in Petersburg

	1745, Boze's experiments with electrified capillaries		
	1733, Du Fay discovers the diversity of electricity in glass and amber	Du Fay's electrical matter as a fire	
	1729, Gray distinguish electrical <u>conductors</u> from insulators		
	1705–1709 Hauksbee: electrical discharge sound, electrification upon cooling, spark jumping across a gap, electrostatic reflection		
	Boyle and Hooke find that vacuum does not translate electricity		
	1660, Guericke's electrification with friction, the later forgotten discovery of electrical conductors and a vacuum pump		
	1600, Gilbert's attractive power of electricity		

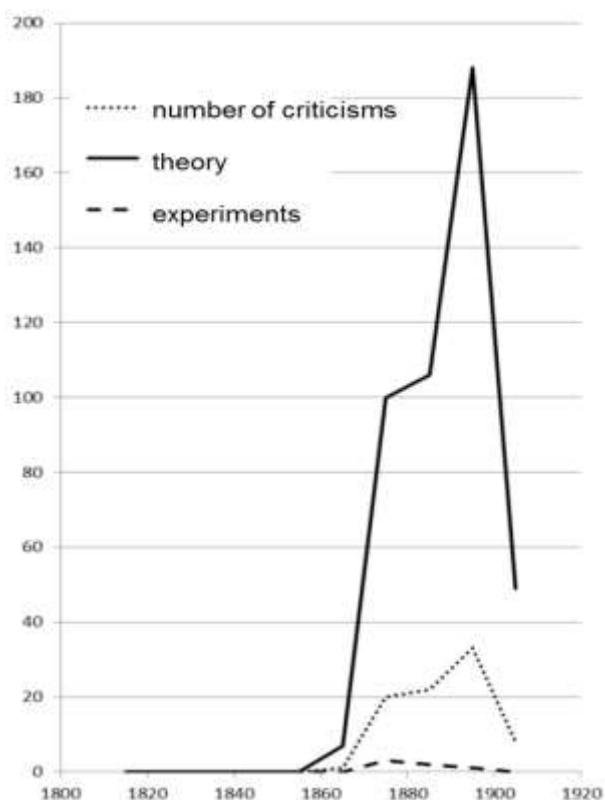

Figure33-16: Critics of statistical mechanics

them were the vacuum researchers like Pascal and Guericke. The nobles of the highest class like Tycho Brahe, Valeriano count Magni, or Boyle were mostly the exceptions among them. Under their leadership astronomy, magnetism, mechanics, optics, physiology, geometry, mathematics and vacuum technology developed, while vacuum technology and electrostatic also influenced all known science of their times. Apart from the Jansenist gnostic Pascal who did not take sides,

Brahe, and the Jesuit Kircher, all of them were Copernicans, including Gilbert's editor Edward Wright; among them only Descartes refused to believe in the existence of a (total) vacuum.³⁵⁵⁹

The sons of non-noble families took the initiative to develop vacuum techniques in central Europe two centuries after similar events enabled the successes of bourgeoisie in Newtonian England. For the development of Slovenian vacuum techniques, the spring of the nations in 1848 was essential; after those political changes the sons of the merchants were given equal opportunities for education, which were once reserved only for the heirs of blue blood. These changes enabled the work of one of the most important and today's oldest Slovenian vacuumists, the Upper Carniola (Gorenjska) merchant's son Alojz Paulin.

The turning point in 1945 brought the new vacuum techniques into the able hands of even more unprivileged Slovenian peasants' sons, who advanced well the modern vacuum techniques. The research of non-Europeans and feminization of the development of vacuum techniques followed to important new directions. The share of women in the development of vacuum techniques is also advancing steeply in Slovenia as the present writer described in his books: *Physics, my profession* (2007), *Anton Peterlin* (2008) and *In the footsteps of Nikola Tesla* (2014).

³⁵⁵⁹ Gilbert, 1991, xli, 318, 329.

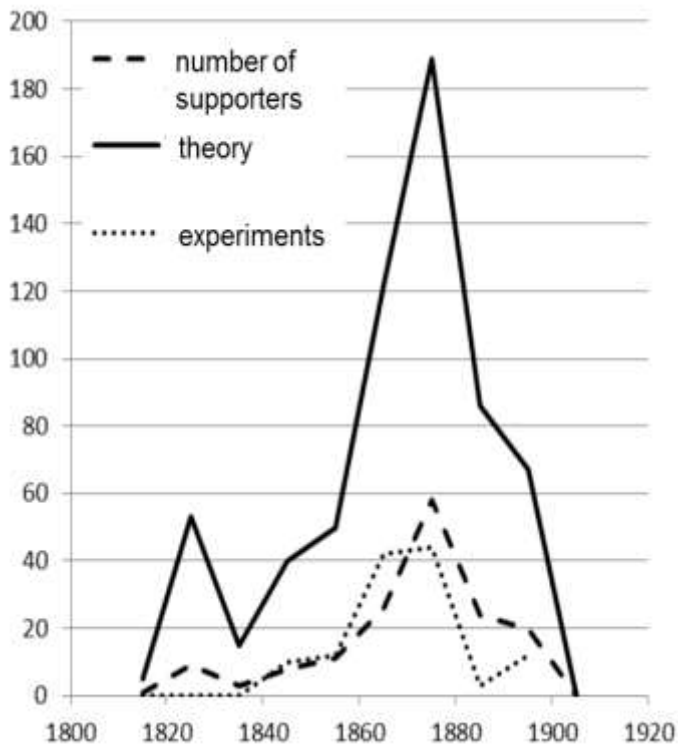

Figure 33-17: Proponents of kinetic theory of gases

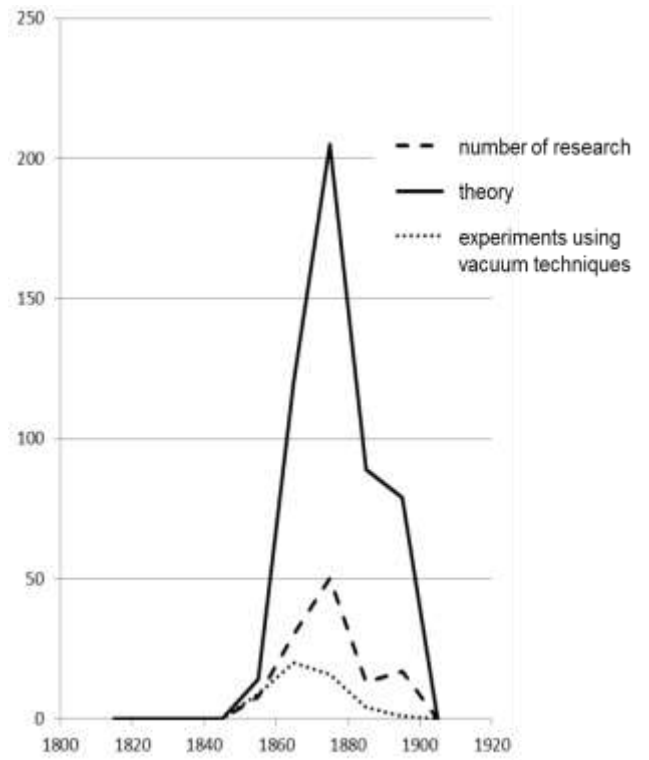

Figure 33-19: Published research in the Austrian half of the Habsburg monarchy in all stages of research of heat

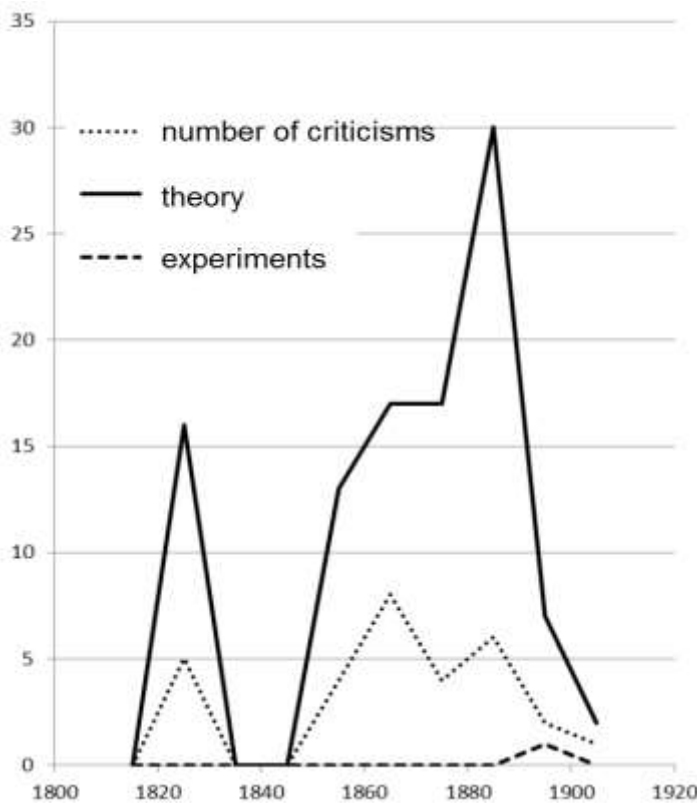

Figure 33-18: The critics of kinetic theory of heat

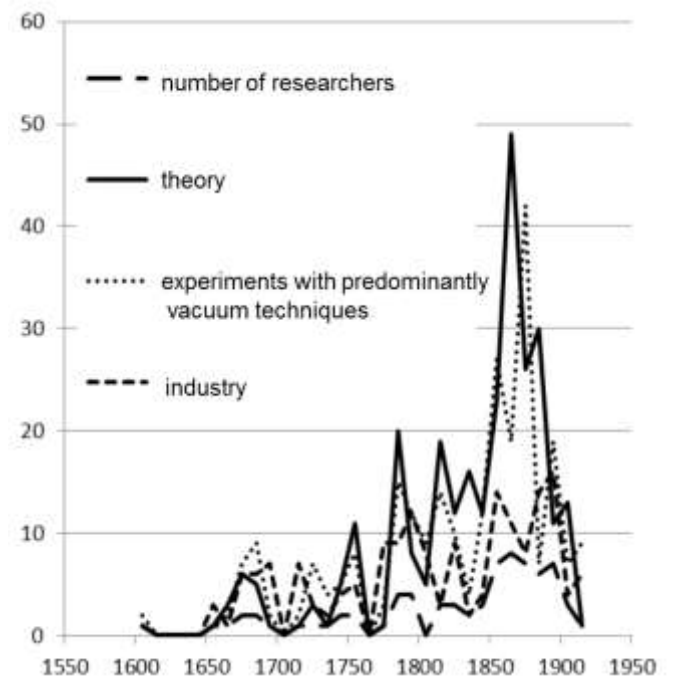

Figure 33-20: Heat explorers in the decade long intervals according to Asimov (1978)

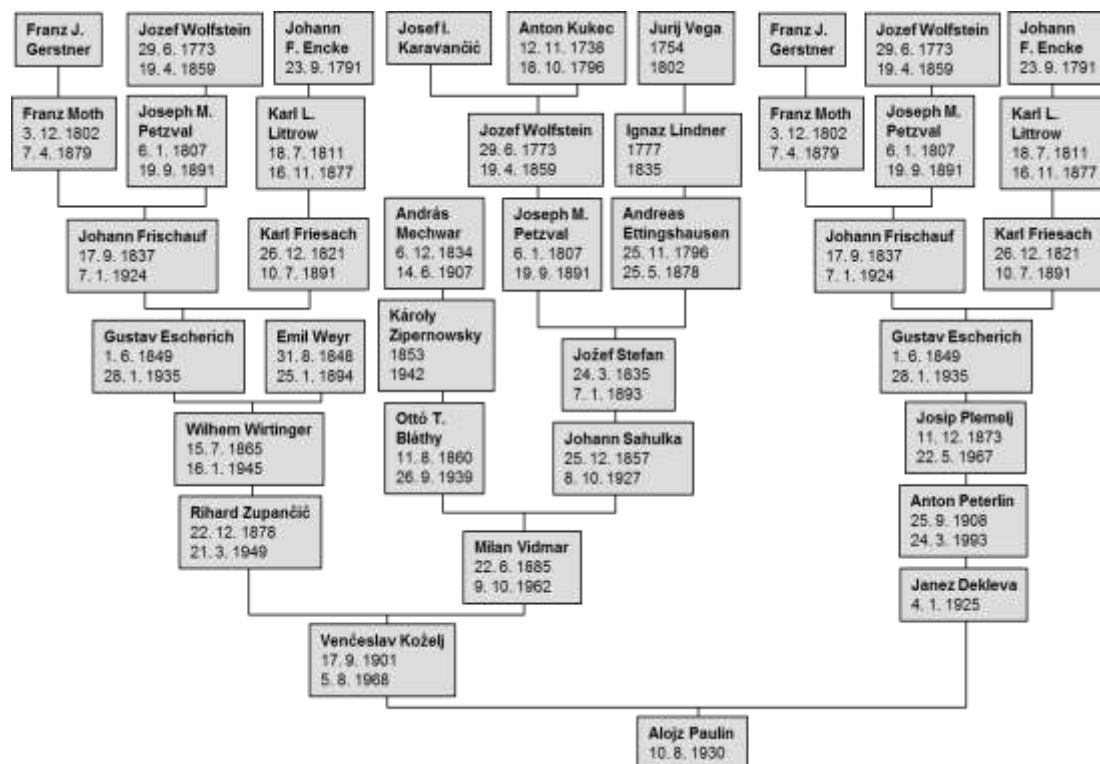

Figure 33-21: Academic ancestors of the vacuum researcher Alojz Paulin; his supervisor at the doctorate is also listed together with his first department head at the IJS.

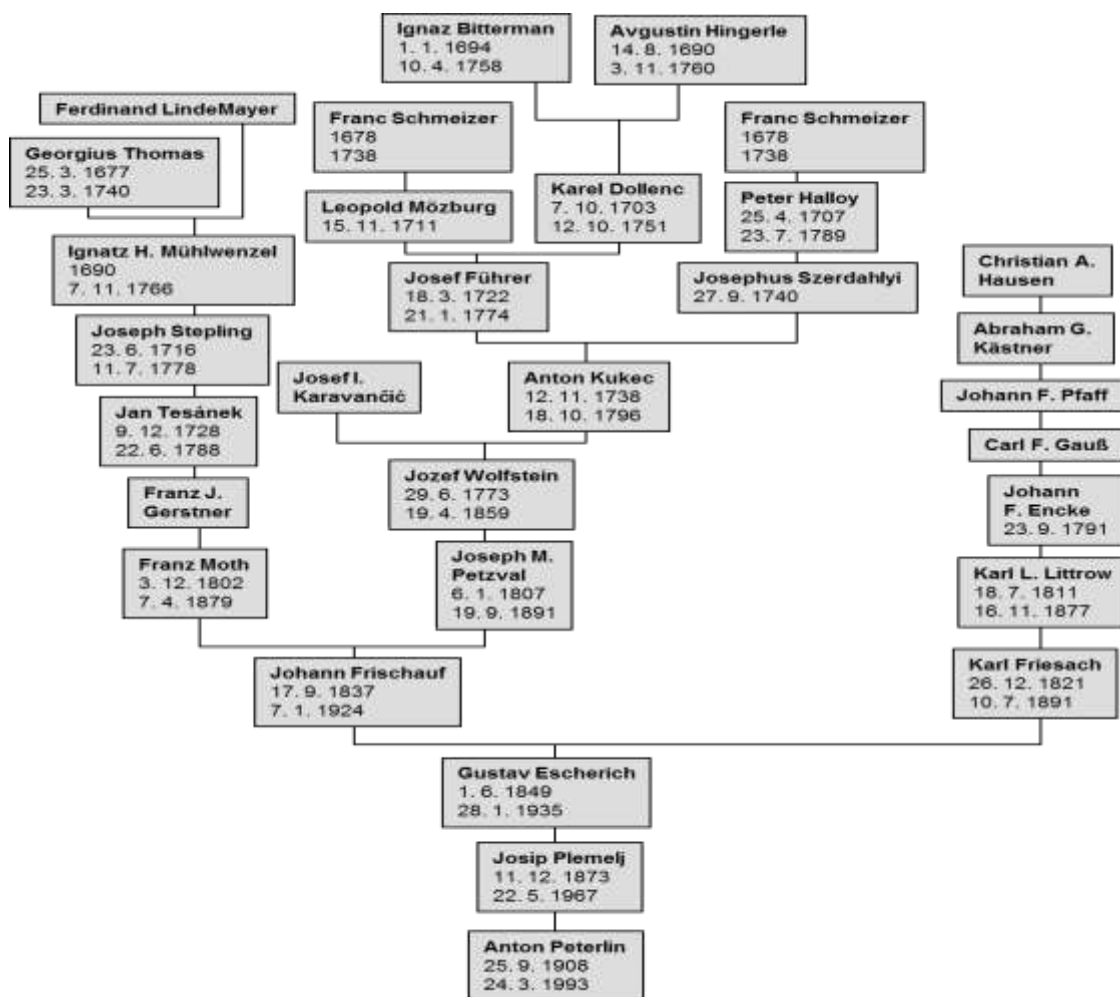

Figure 33-22: Peterlin's academic ancestors according to his Ljubljana diploma in mathematics in Plemelj's class

33.3.5 Conclusions

The development of vacuum technologies in the labs of non-white researchers will certainly define the future. The home environments of educated so far neglected people from Africa, Latin America, Aborigine Australia, the Pacific Islands and the Middle East will bring newly developed ideas that are different from the former merits of white Europeans of Christian ancestry. The concept of empty and nothing in the traditions of these peoples is in many ways diametrically different from the traditional practices of the white Christian folks. Depending on the speed by which the bourgeoisie developed vacuum technology in their times, and after them the farmers' kids and females, the contributions of non-whites can be expected very quickly, as soon as the current brain drain orientation of the transition of non-white erudite to Western universities will somewhat cease to enable the developments of third world global south countries' own educational institutions sufficiently.

33.4 Vacuum as a Limit

33.4.1 Introduction

The breakthrough of non-white vacuum researchers may change the European vision of vacuum as unachievable limits, since the European concept of the limit of infinitely small or large is by no means the only possible. When the "Non plus ultra" limitation was completely erased from

the European Herculean pillars in today's Gibraltar, the magnetic needle became indispensable, with its unusual deviations observed during the sailing of Columbus and Cabot, flourished as desired and therefore well-paid research projects. The type of philosopher ready for this kind of observation was necessarily inclined to an experimental direction, and vacuum technologies soon became the main stars on European flags. Like in earlier adventures of Newtonian borrowing of Indic infinitesimal calculus, the Westerners never quite understood the nothingness of vacuum, but they were nevertheless able to market it.

Modern physics began to evolve soon after the experts had successively discovered their key measuring devices: telescopes, microscopes, thermometers, barometers as manometers for vacuum pumps, portable clocks and sufficiently precise scales seemingly mostly in Europe of the first half of the 17th century because nobody researched the earlier developments of those devices in China and in other places outside the European domains. At various times, scientists differed considerably on the alleged limits of their surveys, but only with the development of their advanced experimental tools the ancient assumptions were rigorously examined. In physics, we have since been dealt with quantities that are in one direction limited, while in the other direction their limitations are doubtful. Such are the pressure-density or temperature, which have lower limits (vacuum and absolute temperature zero), while their upper limits (the highest possible density-pressure or temperature) sometimes seem plausible, but and occasionally not at all. The opinions change according to the current state of research in astrophysics and particle physics. Similarly, however, it is with the electrical charges; it can be completely zero, while its upper limit or charge density is most likely also limited in its own way. Something similar is attributed to the irradiance (flux density) of luminous radiations or the electromagnetic waves in general. Also, a time and a distance seemingly have a lower limit, which is zero, while their upper limits are debatable.

The Hinduists traditionally conserved much broader spectre of matter-energies compared to their later European imitators who limited themselves to the domains outside human brains in funny traditional European borrowing of only partly understood eastern wisdom which included infinitesimal calculus, vacuum resembling nothingness, and economic antifeminist celibate of Lateran Councils (1123/1139) and the Council of Trent (1545–1564) without proper yoga Hindu trainings westernized by Al-Biruni (* 973). Even some European literati were sceptical as they felt that no conservation law was useful as we do not know all energies involved. After the mid-19th century crew of Dutch and British ships finally applied the Hindu Vedic sub-category Upanishads to their physics the scope of the law of the conservation of energy was rapidly apparent to most physicists or even the less educated people,

as was the restriction put forward with Nernst's law, which limited the absolute temperatures to zero, resembling Einstein's velocity of light, or the absolute vacuum as the limit of emptiness.³⁵⁶⁰ Of course, Einstein limited the speed upwards, while the vacuum researchers and Nernst limited the density, pressure and temperature downwards. Contrary to the vacuum limits for densities, the speeds are indeed limited in both directions between the static and the speed of light in the vacuum. In this case, we do not only deal with the limit, but with the actual "static" speed with a velocity = 0 and the velocity of light, although the velocity of light in practical experiments with acceleration of bigger masses in a vacuum indeed turns out to be an unachievable limit.



Figure 33-23: Koller's illustration of fixed and movable wires in Ampère's experiment at the beginning of first Stefan's lecture about electrodynamics and induction at summer semester 1863, read on 21 April 1863 (Koller's notes taken from J. Stefan lectures, manuscript 32).

Of course, the second law of thermodynamics, with its entropic time arrow, remained the secret of all the secrets and the godparent of statistical interpretation of the world in quantum mechanics, which has mastered physics and related disciplines already over a century. Boltzmann combined

³⁵⁶⁰ Feynman, 2000, 118.

mechanics and heat as two expressions of the same invisible physical phenomenon,³⁵⁶¹ but the entropy law soon proved to be beyond any proof developed inside the handy classical mechanics; so, he had to limit the possibility of combining observable macroscopic phenomena with those invisible from the submicroscopic world in a kind of predecessor of Bohr's correspondence principle developed in 1913-1920 to ensure the reduction of a new scientific theory to an earlier scientific theory in appropriate circumstances of its limited validity. Under that principle no today valid theory could be ever falsified like Aristotelian mechanics used to be, which is certainly an abortive attempt to guide present ideas form any kind of refutations as attempt to make modern western scientist immortal like Galileo or Newton despite of false Galilean theory of tides and false Newtonian ideas of eternal chromatic aberrations of lenses.

Certainly, the different branches of physics developed different traditions. While the inevitable tools for vacuum experiments like barometer, vacuum pump or thermometer were available in the middle of the 17th century, the useful electrical charge gauge was not designed for another hundred years.

The smallest and largest parts of the substance have similar problems. With the development of physics and chemistry, the honor of the smallest particle of matter was attributed to the atoms, and later to the nuclei down to the quarks, and even further or deeper. Limits are (still) not even on the horizon. For the most distant largest stars, the situation is comparable in its own way, as our greatest dimensions are constantly expanding with new discoveries, while repeatedly magnifying both the age and size of the universe. For both directions of measurement the microscope and the telescope appeared initially as very usable device, completed after the development of glass processing in the Netherlands and in Venetia which enabled the inventions of the telescope and the microscope around 1600. The invention is mostly attributed to craftsmen such as Cornelis Jacobszoon Drebbel (Drebel), Jakob Metius, Hans Lippershey or Zacharias Jansen in the Netherlands around 1600, but most of its profits were earned by the ingenious Galileo a bit later. The lucky "first come, first meal" is not always valid, but the guy must be also at the right time in the right place, as

³⁵⁶¹ Heisenberg, 1998, 15, 69; Petković, 1998, 143.

Galileo used to be in the middle of the wealthy gullible Venetians. Galileo was clever enough not to tell his Venetian masters to loud that the invention was not entirely his own.

This opened the European view into the Indic feelings of infinitely small, infinitely large and infinitely distant. Those feelings soon became established in a differential calculus, where they found the first general and useful European form in 1660 with Newton and Leibniz's borrowing from Indian researchers by the mediation of Jesuit missionaries, as recently proved by Chandra Kant Raju's (* 1954) empirically decolonizing mathematics and physics into Ubiratan D'Ambrosio's (* 1932 São Paulo) ethnomathematics. The mechanics of ballistics and astronomy with the theory of orientation in the space gained the most from those novelties which the imperialist westerners borrowed outside Europe.

The communications between scientists through an accelerated exchange of ideas triggered a new way of thinking (almost) hostile to philosophy. In the middle of the 17th century, the Englishmen named this novelty with their insightful title *Experimental Philosophy* to promote their empiricism. Why did this happen right in the middle of the 17th century? Among others also because it soon turned out that science with vacuum pumps included can also be sold for the nice valuable prices. A century later the Victorian imperialism needed further distinguishing of westerner way of thinking, therefore the Kantian English historian of science white supremacist racist William Whewell (1794-1866) coined the term *scientist* in 1833/34. Certainly, the white scientists as the master of them all superior just because they had more guns and will to use them against their colonized coloured victims.

Soon it was clear, unfortunately, that the atoms were submicroscopic, and most of the stars were far behind the capacity of telescopes. Thus, even the special tools equipping the human eye by lenses could not determine their whereabouts. Fortunately enough, few more possibilities popped out with the observations outside of visible light which the nature intended for humans. We therefore use the electron microscopes and "telescopes" detecting the invisible rays. Already in the early 19th century it became clear that light

has a much wider spectrum than it is perceived by human eyes. The ultraviolet and infrared light were traced primarily by their chemical and thermal effects. Prior to Röntgen's discoveries, their spectrum was not limited. The frequency of fluctuations included the thermal phenomena of infrared light, and the electromagnetic fluctuations have even lower frequencies. Thus, by the renewed ideas, a century and the half old phlogiston theory reappeared because the good old fans of phlogiston also claimed that the electricity, heat and light are the degrees of a same burning principle called phlogiston. In Maxwell's theory of electromagnetic waves in a vacuum, which, of course, was mathematically much more complete, the energy principle simply replaced once discarded phlogiston. When the newly advanced approaches of the Jew Heinrich Hertz and the Croatian-Serb Nikola Tesla pushed the Maxwellian waves into the world of industry and entertainment, the walls suddenly broke down into the global Earth of contemporary globalization.

Again, the space-distance or time seems to belong to somewhat different species. Both have limitations on their lower sides, but their upper limits are probably not attainable, just as in the cases of temperature or density-pressure. The distance zero between any objects would be contrary to the principle of the exclusion of the Viennese Jew Wolfgang Pauli. Otherwise, we want to describe the time interval zero in the conversational language as "at the moment I'll be there"; in real life, something like that is not possible due to Einstein's relativity theory. In the opposite upper direction, the time and distance-space are limited or not: it depends on the theory that currently prevails in astrophysics. Basically, the time also has a gigantic theological significance. Parallel with vacuum pumps, the clocks became more and more accurate,³⁵⁶² while nowadays time is by far the most accurately measured physical unit. The most accurate watches were used by astronomers all the time, because soldiers and traders gave them and the seafarers the greatest support. On the other hand, more accurate clocks allowed a more precise description of the sequence of natural phenomena. For the first time, initially shy and unconscious, researchers have introduced a time component into their study of natural phenomena after humanism introduced a sense of time and aesthetics as illustrated in the

³⁵⁶² Pipunov, 1982.

work of Francesco Petrarch (Petrarca) who collaborated with Barbara of Celje father-in-law Bohemian king turned emperor Charles IV (1316-1378) in the 14th century. The time has always been present in the Hindus' minds in the form of an inevitable time of *kāle*, which is identical with God himself.³⁵⁶³ while the Westerners were willing to introduce time as their own basic concept only after the manufacturing processes of their oppressed workers demanded accuracy. The consciousness of the dynamics (time component) of events in nature finally penetrated only with Darwin's evolution and Boltzmann's entropy after the middle of the 19th century as the echo of their neighbouring industrialized working process. The arrow of time-entropy was born for scientists and against delays of disobedient lazy workers at westernized factories, while the Japanese started introducing their now legendary timing only with state decrees half of a century later. Inside the former European feudal system just the amount of tithe was demanded without any interferences in its production, while the modern capitalist doesn't want just the work done, but also wish to control then workers' time spent at a working place. The same system was introduced for (lower) education where not only the endorsed erudition matters, but also the time spent behind the school benches as a kind of acculturation.

The eastern arrow of time was introduced into western working processes and entropy concepts because of economic needs while its puzzles as singularities never really fitter the western minds. The vacuum soon became the important basic element of such singularity, which appears in the vast majority of allegedly point-like centers of forces. They were best developed in the imaginations of the Jesuit Bošković from Dubrovnik, who visited Ljubljana at least three times and spread his ideas among Slovenian ancestors. Soon after, his indirect student, the Slovenian Jurij Vega, began to solve the task of a body that would fly through the vacuum to the center of the Earth. Would it stop, flew through, return, or maybe it would rather oscillate around the center of the earth? In all cases, this was an example of an idealized movement in a vacuum, while the argument of possible or acceptable solutions was highly revered and loud.

In mathematics, of course, things are completely different, as the mathematicians do not tolerate so many borders that we the physicists have imposed. The other sciences are even much more subject to the borders, which in the modern ages gradually take over the leading roles and money from the hands of physicists. Thus, we have chemistry with eighty stable chemical elements comprising a total of 252 nuclides that have not been known to decay, and it is unlikely that we will ever find in the nature the additional stable ones. In the other hand, there is no real restriction put on radioactive nuclides that can be artificially created. The number eighty is surely interesting at the same time with its Western recognition, which for the first time unanimously adopted the periodic system of the Slavic genus; before Mendeleev, Lavoisier and many others tried to draw different tables of elements that even additionally contained some or other medium for the transfer of energy. It is similar in biology, where we have to do with many living beings, but their number is not infinite. The human being has twenty-three pairs of chromosomes, which is once-again a limitation, and with it, the investigators of genome get the most research money now and likely also in the future. Likewise, is with the life expectancy (longevity) which could be extremely short, while the maximal lifespan appears to be limited, although (yet) there is no biological law that declares the necessity of death. So, the clever Jewish New Yorker Richard Feynman even cried out that he may outsmart or even bribe the death itself, as the advancement of biology and medicine could soon discover all about the healing of a serious illness called death, which is the illness mostly just in westerners' eyes.³⁵⁶⁴ Despite of such prominent ideas, even the genius of Feynman's sort finished his times in 1988. In modern American visions, the vacuum of zero-death is a great taboo theme, and instead of the direct unquestioned title death they preferred the term passed away or the deceased, with American Protestant cemeteries being more the meadows-parks, then the places of Confucius-like paying respects to ancestors. The day of the dead (of all saints) celebrated in central Europe would be a perfect alien for most Americans, especially right after Halloween's humor. The reflections about zero and vacuum

³⁵⁶³ Kohler, 2011, 22.

³⁵⁶⁴ Feynman, 2000, 100.

always had a strong Indian touch and are therefore a hard nut for Westerners' focused thoughts preferring to see just his or her own (full) pocket without emptiness.

It is similar with modern technologies, including those the most important: while for half of a century they have been fighting around the age when oil is expected to run out, according to recent studies, that oil is still rapidly generated in the interior of the Earth, which declares the oil-panic as the false alarms or fake news invented for the profits of the well-defined industries that are competing one against the other to lower the prices of Muslim, former Soviet and Venezuelan oil.³⁵⁶⁵ Thus, the friend of the writer of these lines, the leader of the TRIGA reactor Matjaž Ravnik, in his book *Greenhouse (Topla Greda)* criticized the use of fossil fuels under the influence of then popular reflections on the *Boundaries of Growth*,³⁵⁶⁶ which I in my physics student's reflections described in the *Ljubljana student Tribune*, rebaptized in the *Meadows' Growth of mediocrity margins (Travniška Rast omejenosti)*.³⁵⁶⁷ Of course, most professional ecologists reject not only fossil fuels, but also nuclear reactors, which is certainly not exactly the positions suitable for most physicists.

33.4.3 *Europen Limits*

Vacuum is today clearly a limit, to which we approach by excessive pumping or gettering. In the past centuries, many other opinions about this kind of activity have undoubtedly been considered. In the European tradition, the view of the vacuum, the empty, the zero, the limit, and the infinitesimal calculus remain mysterious. The Europeans borrowed most of these concepts from the Easterners, especially from the people of India, while the Westerners became only partly familiar with some marginal aspects of Indian philosophy. Thus, the number zero, limit and infinitesimal calculus were assumed only for the sake of easier European calculation, without understanding what exactly they do while calculating. In the case of the number zero, the Arabs were mediators and the process of borrowing was never questioned much. In the areas of the limits and the infinitesimal calculus two antagonist European groups fought

for their supposed priority gathered around the Leibniz's *Acta Eruditorum* in Leipzig and around Newton's *London Philosophical Transactions* of RS. They hid the fact that their "inventions" were brought by Jesuit missionaries from India, where also the famous Matteo Ricci worked in his era.

In addition to the infinitesimal calculus, the Europeans were "infected" with a probability calculus, developed from the theory of games that were very popular in the high societies of the 17th century. The centralized countries with a general military commitment have encouraged demographic statistics and statistical methods in mathematics. At the same time, a mechanical view of physics was born; but both novelties did not mix until the second half of the 19th century, that is, for two full centuries after their genesis. The needs of mechanical physics demanded a new mathematical approach, which could have played the role resembling a microscope in mechanics or biology. The idea of the infinitely small and unlimitedly great has not only been established in biology and astronomy. The numerical series entrusted infinity to mathematics, and the need to determine the surface of irregular bodies (vortices, surfaces of revolution, solids of revolution) also brought it into mechanics in the form of an infinitesimal calculus. Such calculus was already offered by Huygens and by the English mathematicians to solve individual cases, but only Newton and Leibniz developed a general form of an Indian model that became a kind of microscope for the observations of events in mechanics and astronomy. Due to the accompanying prestige, the deepest dispute over the discovery of infinitesimal calculus has blown up, but the Jesuit missionaries from India, in fact, brought it to the networks of both main quarrelling protagonists, Newton and Leibniz. Despite of modern Indic science historians, the westerners continue to emphasize Newton's championship besides Leibniz's independence with much more useful Leibniz's symbols as the basis of modern terms of infinitesimal calculus. The ancient literati of India today justifiably appear to be a kind of modern synthesis in this once seemingly European dispute.

During the eras of Matteo Ricci and A. Hallerstein, it would be difficult to find the autonomous reverse influences of China on Europe or the independent Chinese orientations in mathematical physics that

³⁵⁶⁵ Engdahl, 2014.

³⁵⁶⁶ Meadows; Meadows; Randers; Behrens, 1972; Ravnik, 1997.

³⁵⁶⁷ Južnič, 1979, 10.

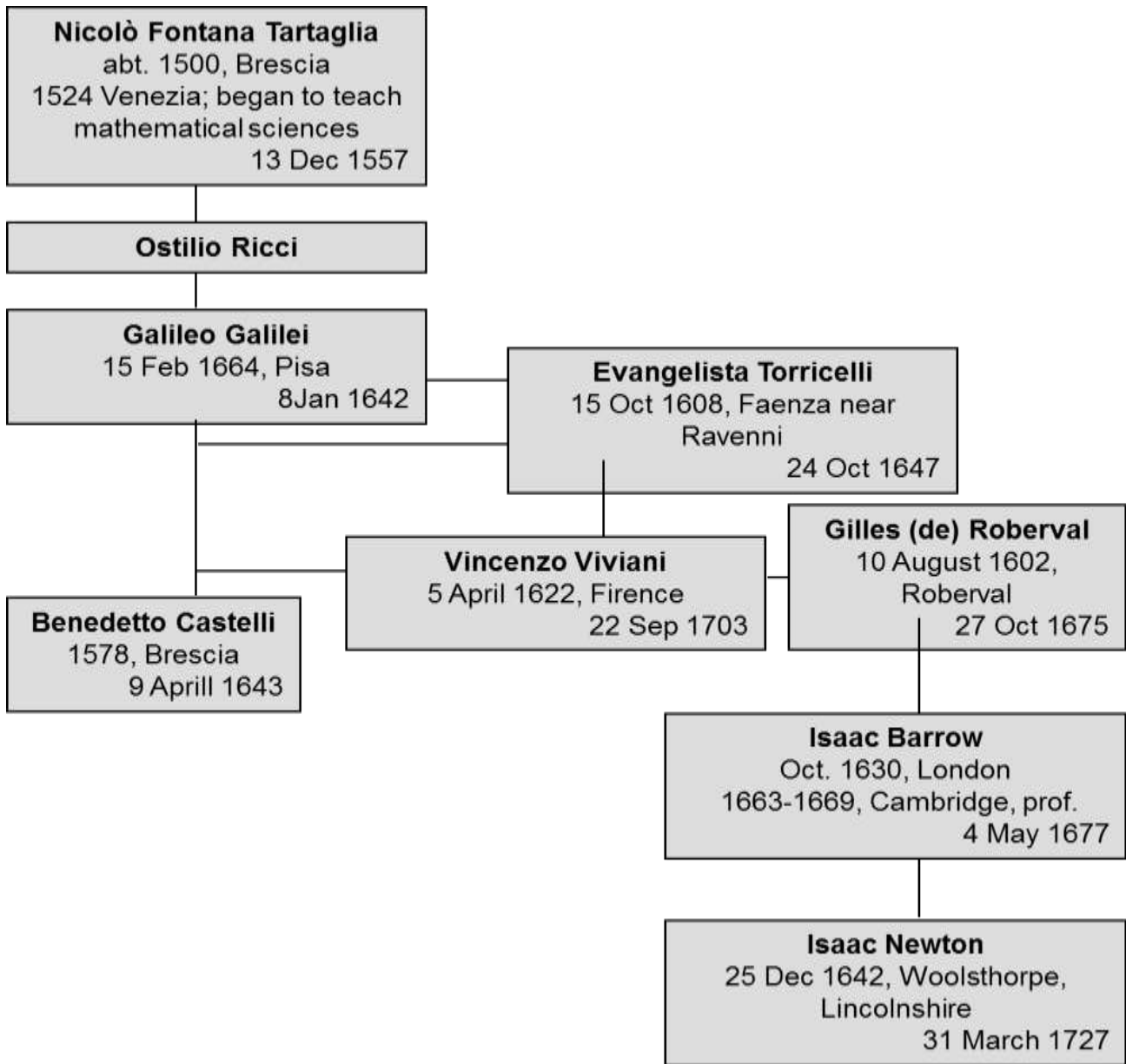

Figure 33-24: Italian inventors of the barometer, first described in Torricelli's letter in 1644, and its British users.

Table 33-4: Birth of a Modern New Science

	New Tools	Areas of Experiments	Methods	Organizations	Theories	Thinkers
1550					Motions of Earth	Copernicus
1600	Telescope microscope	Astronomy, biology	experiment			Galilei
1650	Barometer, vacuum pump, useful clocks with spring or pendulum	Mechanics, optics	Infinitesimal calculus	Academies	Optics, general gravity	Newton
1700				Scientific Newspapers		

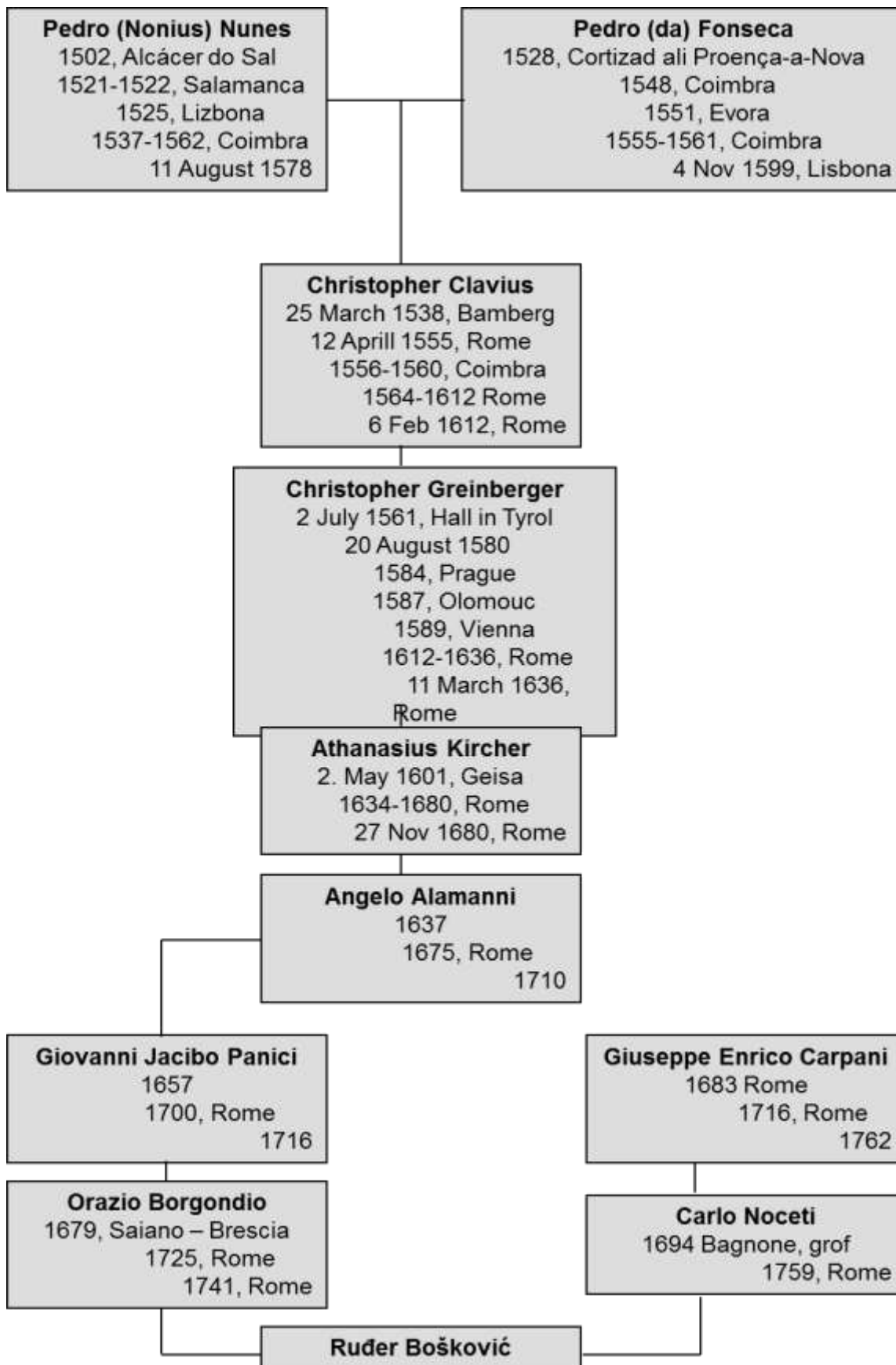

Figure 33-25: Academic ancestors of Jesuit physicist Bošković up to the German-Roman Jesuit vacuumist Athanasius Kircher. The numbers in succession show the dates of births, the study of physics with mathematics or relevant academic promotions, the chairs of physics and mathematics held, and finally, the year of – death

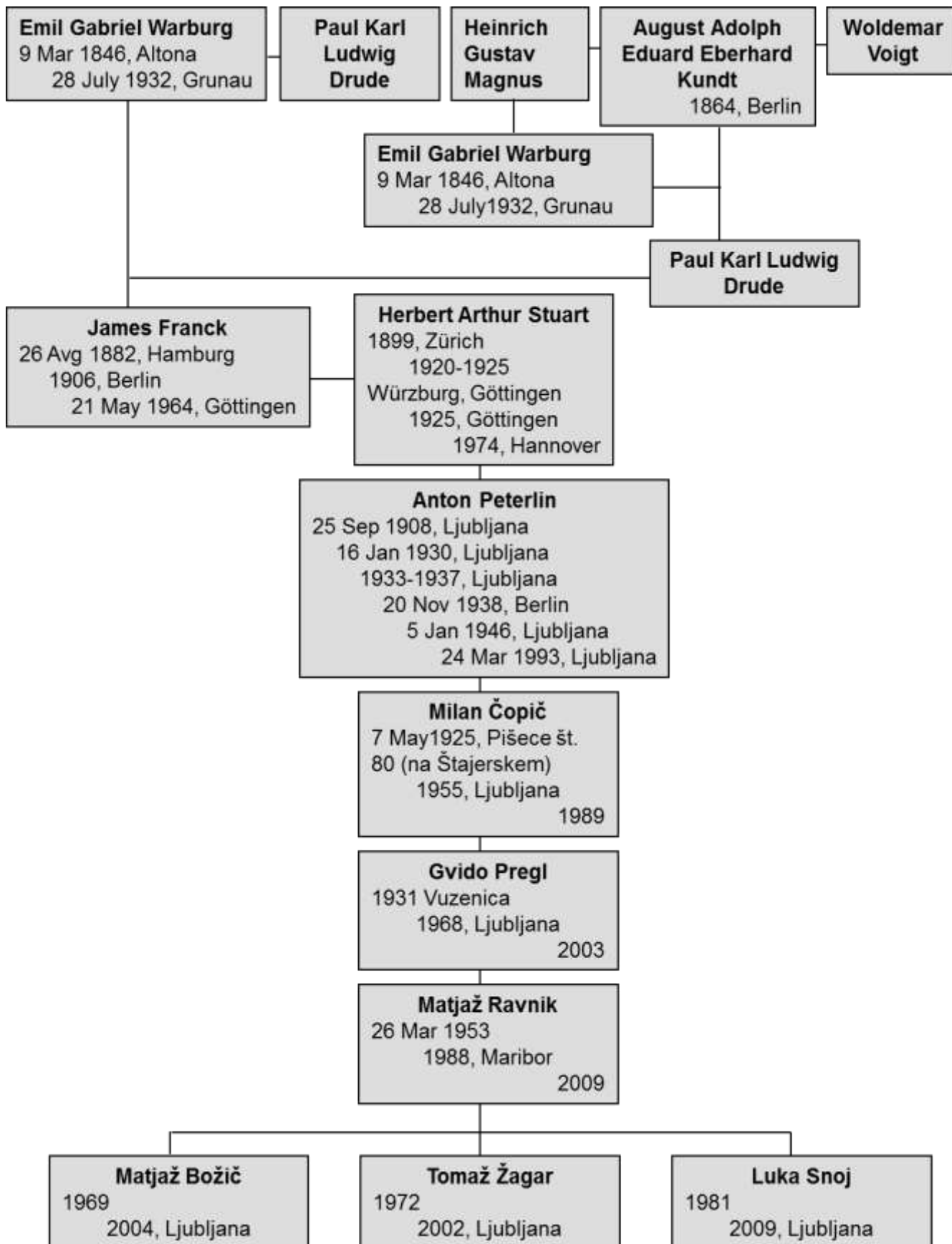

Figure 33-26: Matjaž Ravnik's academic ancestry up to German vacuumists Warburg, Kundt, Magnus and Drude

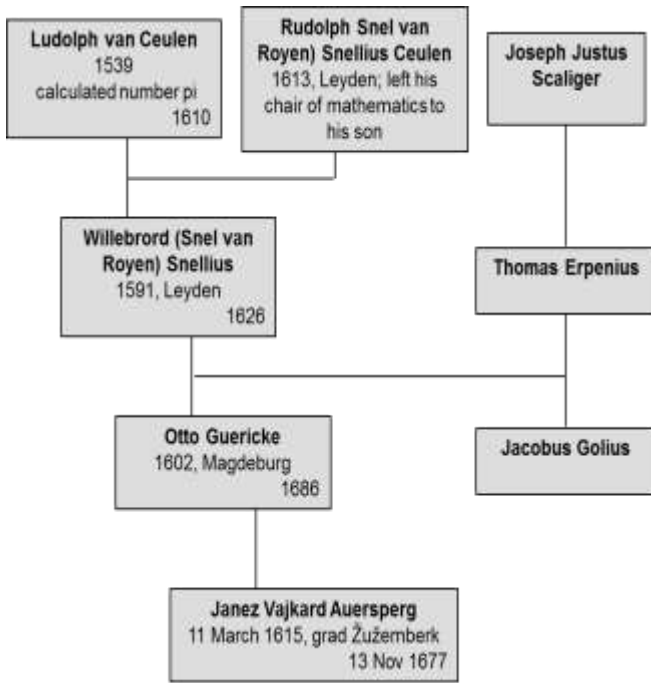

Figure 33-27: Academic ancestors of Otto Guericke as the vacuum pump inventor and a kind of teacher of his decade and a half younger prince of Auersperg

would be comparable to the (alleged) Indic pioneering invention of the infinitesimal calculus. As the Europeans did not know or did not want to introduce the Indian philosophic concepts into their own traditions, their ideas of the zero as well as about the limiting approach remained as an unwritten piece of paper (tabula rasa) like vacuum experiments, which had indeed worked successfully in Europe over the last four centuries, but no one in Europe and its satellites really knew why they succeeded. Similarly, the modern English cuisine enjoyed and its borrowed goodness all over the world of English colonies, while it never really Anglicized those borrowed cooking knowhows. The vacuum technology was gaining profits, while its theoretical background remained a mystery and soon even an unwanted object of guesswork, like that of silencing the infallible doubters of the impossible foundation of the Copenhagen Manhattan interpretation of quantum mechanics with the famous shut up and calculate included. Similarly, of course, behave the dogmas of the Christian faith along with the Credo quia absurdum. It is by no means unacceptable for European people to believe in such impossible dogmas, while, for example, they seem to sound funny to the traditionally unbelieving Chinese. Through the lovely happening during the

last century, it has become clear within the debates about the reality of the results of vacuum experiments, that the vacuum cannot really be empty without any radiation energy because we only used to pump out the material substances from it.

With Einstein's connection between energy and mass, this would probably mean that the pumping of ultimate vacancies deeper beyond modern capacities is indeed a shift from the hollow to an emptiness, since the exhausted particles of the substance could, by the way, be generated from resided energy. Thus, the ball returned to the Descartes' line defined four centuries ago, on the question of what is in fact missing in an empty glass or in a vacuum receiver. The dispute between Otto Guericke and the Carniolan Prince Janez Vajkard Auersperg during their pioneer vacuum experiments in Regensburg in 1654, nowadays apparently gets young kids all over.

33.4.4 *Projection of the Vacuum of the Future*

A healthy common sense loses its absolute significance in parallel with the developments of modern science. First, the Copernican Galilei replaced the common sense with a more experimental way of perceiving nature, and then Newton even renounced his promotions of any common sense's hypothesis. Thomas Young and Fresnel subsequently discovered phenomena that opposed the experiences of common sense. This means that modern experimental tools are becoming more accurate than human senses which can no longer be fully trusted, at least not in science; of course, they remain valid with interpersonal relationships and in love affairs. As a memory of the former values, human senses still define the language of science because the physics in its classical form is divided into mechanics (touch, hearing, organs of balance for gravitation), optics (vision), thermal theory (touch again), and electromagnetism with the tongue as the original electroscope.

For Maxwell, the common sense was merely a handy illustration of scientific and mathematical reasoning. But such an idea somewhat overtook his time, since it consciously denied the objectivity of human

performances, just as Galilean experiments had done before with human emotions.

In the following generations, the theory of relativity further subtly contested the myth of the absolute character of human imaginations. The quantum mechanics finally enacted the failure of human representations in all those dimensions and speeds that went beyond the normal human experiential environment. The human commonsense judgment remained in force as a limiting case only to the point where it was possible to entrust human senses by the famous Prešeren's joke: Just the shoes belong to the equestrian; outside the visible and outside the area of Jernej Kopitar's professionalism we should live the decisions to the other expert criteria. With this, anthropomorphism lost its ground, although with the newly advanced technologies the boundaries of human perceptions and normal living environment may possibly extend into the promising future of the Internet and the Anthropocene.

The development of scientific mathematical reason naturally influences popular common sense, especially during compulsory schooling and possible readings of the popular scientific periodicals. So, today most people no longer doubt that the Earth is round. We similarly believe in the movement of the Earth, which had seduced Galileo and at the same time celebrated him as a scientist. We also accept Newtonian colors as an objective property of light, and not merely as the consequence of the physiology of the eye or painters' mixes of colors that the poet Goethe wanted together with the revolutionary friend of the nation Jean-Paul Marat. The independence of the gravitational acceleration from the mass, however, already pushes the Aristotelian common sense to the problem, while the wave properties of electromagnetic waves and light still do not interest much the folks' common sense.

The development of physics of small and fast particles has limited human common sense reasoning to the areas that can still be controlled by the ingenious human organism.

The healthy common sense has a delay of several centuries behind the fundamental discoveries of physics. How about the language used in the conversation? According to it, the Sun would still

rise, its rays are more particles than waves; its heat does not seem to depend on the motion of particles. The conversational language remains deaf for changes in physics development or stay behind for a great space of time.³⁵⁶⁸ Thus, vacuum still does not have the right position in today's spoken languages, although we often joke about shifting from the hollow to the empty, or about the fear as the cavity which has nothing around.

The feedback reappearance of scientific achievements in commonsense opinions of the majority has a strong backward impact on the material support of science. The opinion about science was poor in the main Western European research centers around the years 1710-1740, 1930 and 2020, and good in 1660, 1800, and 1900. The high opinion yielded more research money. After the First World War, the Germans set up committees against restricting school hours of mathematics as A. Sommerfield recalled,³⁵⁶⁹ and the doubts were even deeper following the subsequent economic crisis. Misconception in science opens the door to parapsychological bioenergy resembling spiritism, Mesmer's or Wilhelm Reich's ideas, which are like the aliens of Erich von Däniken. Of course, trust in science also has its own geographical component, since the Hindu records in the Vedas greatly outweigh the modern scientific truths for their believers, like the Koran for strict Muslims or the Bible for Christian or Jewish fundamentalists. However, we cannot easily connect the reputation of science among the average people with their economic or scientific everyday life:

1. Wars do not always reduce the popularity of science; if the First World War did it, the effect of the Second World War was quite opposite.
2. The fluctuations in the popularity of science cannot be uniquely linked to periods of economic crises that follow much shorter intervals; nevertheless, there is a connection between the two phenomena.
3. In the first half of the 19th century, the popularity of science promoted by steam engines

³⁵⁶⁸ Price, 1980, 45–65.

³⁵⁶⁹ Heisenberg, 1975.

and telegraphs strongly stimulated research. After the First World War and during the great economic crisis, quantum mechanics with its overpraised statistics was born in the middle of the great unpopularity of mathematics.

4. The unpopularity of science among the broad masses of people does not always mean less money for it. Those who control a lot of money appropriate decisive power without the (democratically) fooled masses of common people, even though their influence could also be considerable.

In this sense, it is very difficult to predict which move might influence in one way or another the popularity of vacuum techniques research in the eyes of the average common people or even in the eyes of the rulers who have the decisive keys of money bags in their hands. Very difficult, but in no way impossible.

33.4.5 *General Conclusion*

The modern development of astrophysics establishes the possibility of observing history from the global perspective of the development of the universe from the Big Bang down to its contemporary contradictions. Thus, the history of physics becomes part of physics with the exploring of a vacuum included, after Karl Marx has long argued for the present as the last & final part of history. Naturally, the astrophysics offers just a bird's eye view; with it we cannot outweigh the efforts of individual types of sciences, each of which is trying to master their field of research by special centuries-old traditionally embedded methods. Astrophysical view of the world, of course, will never afford to look at the individual or to any narrower problem of the development of vacuum technologies, but at most it will be able to statistically describe its wider environment. By doing so, it will give new boundary conditions to individual histories and the realms of research itself, but it will by no means eliminate the differences between them or bring them together in a unified science of the theory of the entire global Anthropocene as a new era in which man does (not) responsibly perceptibly affects the Earth. Such a thing would be simply too expensive, just as the

genome exploration had to be limited to a few thousand samples, knowing in advance that this was insufficient for serious insight, but barely enough to look at the humanity from a distant bird's-eye perspective. Of course, nobody looks a gift horse in the mouth, and the researchers of the genome certainly did not reject their good wages because of some deep doubts about the meaningfulness of their projects.

The basic problem of physics and its history remains the daily metamorphosis: today, we are exploring physics as part of the exact science, but tomorrow our today's work will become part of the history of physics as part of the humanities, at least from the American perspective of the division of research disciplines. The affair of professor of physics and mathematics, Alan Sokal (* 1955), who mocked the philosophers of science,³⁵⁷⁰ shows a never-ending gap between the exact sciences and humanities; so, we can think of how physically hard or even schizophrenic must the physicist feel during his/her yesterday's and tomorrow's research work, when his/her own achievements are immediately attributed to his/her humanistic sworn enemy. Competition between Exact Sciences and Humanities is a consequence of the modern school system, which today has the upper hand that prefer the first; the Jesuit or Classical Chinese school examination system favored humanities and did not allow such severe conflicts between the two ways of acquiring knowledge. I feel like a physicist and a trained historian in the same person - perhaps this gives me the opportunity to resolve the conflict between two cultures of Charles Percy Baron Snow of the City of Leicester (* 1905; † 1980) with future Sokals included to ensure some tolerance between the two conflicting parties that would bring better funding to both? The dispute between European Exact Scientists and Humanists looks like a divide et impera: in fact, both sides glorify their own search for the truth, while a true-minded true-speaking politician would be disaster for his party in the pre-election battle. Of course, we could afford only a (silent) alliance between the two ways of finding the truth against the half-truths of the rulers who decide about the distribution of money among the researchers.

³⁵⁷⁰ Sokal, 1996; Sokal, 1996b.

Conclusions need deep thoughts. Thus, dear reader, we reached the end of the book, the final conclusive chapter on the vacuum, that is, to the edge of voided nothing itself. Of course, it was always clear that the vacuum is empty just by name, otherwise it is full of wonders and even very useful. It is indeed quite empty, but with its emptiness it allows the adjacent fullness to play a decisive role in recent and modern technologies. We do not explicitly know what the vacuum is missing and what its different full stuffed neighbors have. But, in the limelight of development of the vacuum techniques of the last four centuries, we gradually developed a feeling about where the whole history of science is focusing; we are aware of the sorts of future scholarly education and, above all, we could predict almost all about the kind of technologies our children and grandchildren will design.

The history of learning and the development of past vacuum techniques is our new signpost. The wrong moves, slow, uncomfortable congestions and triumphs of the former days are lighthouses that a clever observer uses to avoid the future obstacles. Perhaps the history as the teacher of life according to Cicero's *Historia magistra vitae* is sometimes extremely unsuccessful, because the powerful people obviously never learn anything from their past. But nothing like that matters in void vacuum. Again, and again, the same repeated mistakes of the mighty have their own charm that entertains us while studying them.

The vacuum technology has been an indispensable part of experimental physics for centuries. In its experiments with the smallest particles of the substance it established the modern physics. For half a century, vacuum elements have been the basis of most of the world's major industries: from fun to computers and accelerators. The modern theory of vacuum tailored the future of physics. On the way to such success, there were thousands of debacles and at least as many successes. It is the greatest pleasure for me that Slovenians greatly contributed to the development of vacuum technology. Therefore, I may not be reluctant to over-emphasize their successes in any way.

Three centuries passed between the first interventions of Slovenes in the development of vacuum techniques under the prince of Auersperg

and Peterlin's design of the Jožef Stefan Institute. In the meantime, the situation changed radically: vacuum techniques became the driving force of economic progress, and Slovenes became a recognized European nation. All this and something else was told by our story...



Figure 33-28: The first Slovenian vacuum researcher Janez Vajkard prince Auersperg with a modern cathode tube under his armpit observes his and Guericke's emptied hemispheres as designed by Urška Južnič in 2004

In 1993, when my classmate as editor-in-chief of the journal *Vakuumist* dr. Peter Panjan invited me to write for him, as an American with Slovenian roots I saw this as a first-rate opportunity for effective propaganda of American scientific criteria in Slovenia. Above all, it was the fact that the history of vacuum and vacuum techniques within the history of science in the United States has been a full-fledged research industry with many important chairs at leading universities developed throughout the last century. The Europe is lagging somewhat behind here, and Slovenia must become much more interested in promoting its past merits. Slovenes still do not have any kind of department, nor the institutes focused on the history of sciences. Unfortunately, the only Slovene journal designed in that direction, the magazine *Zbornik za zgodovino*

znanosti in tehnike, was stopped shortly after the death of its main advocate and editor, my friend Fran Dominko.

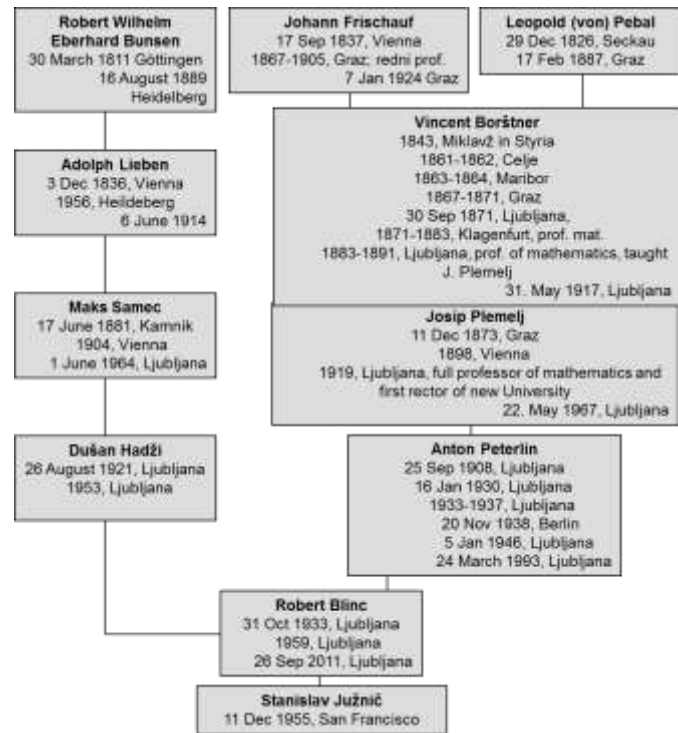

Figure 33-29: Stanislav Južnič's academic ancestry tree following the physics studies of Peterlin's advisor in his doctoral studies of physics Stuart down to the "inventor" of Phlogiston, Stahl

In Slovenia, the local merits have been almost forgotten because of the propagandist aggressivity of foreign historians of sciences; as urgently as possible, the Slovenians need to catch up with the progress of histories of sciences of the Western world. The opportunity missed never returns. The problem was mainly that in the US the history of vacuum and vacuum techniques inside the history of science is a part of the humanities, and in Europe, above all the working scientists themselves are trying to keep hands on it. I have always been aware that this is primarily an ideological dispute in which a scientist seeks to maintain a monopoly over the history of his own science, even though this is essentially impossible. Even a politician can outsmart historiography only temporarily, because sooner or later his or her hidden mostly greedy motives became obvious. In any case at least in the next generations of more independent researchers. The historian of vacuum and vacuum techniques

inside the history of science uses historical methods in his work, rather than physical or chemical methods; therefore, he or she must necessarily have (also) a historical education if he or she does not want make too many mistakes. As a result, I graduated in physics but I got my masters and a doctorate in history. I've already figured out where the main problems might be.

During our half of a century long research of the history of vacuum and vacuum techniques within the history of science we discovered and proved many important merits of the Slovenian people. I would like to emphasize, basically, the far too little-known fact that the beginner of vacuum techniques and the inventor of the vacuum pump Otto (von) Guericke explicitly stated in his only book the comprehensive help of Janez Vajkard, Prince of Auersperg, born in the Žužemberk castle. Guericke did not say much else about any other person in his book, which shows how great and highly esteemed was Janez's help which facilitated the development of the first vacuum pumps. Because at that time the first Slovenian vacuum researcher Janez Vajkard Auersperg was influential first minister of the entire Habsburg monarchy in a position just below the emperor, we can think that Janez's (John) thoughts about the vacuum were not irrelevant. Of course, we also collided with the doubts: how could a son of a small nation beneath the southern slopes of the Alps so develop such basic vacuum techniques that he made him was a champion innovator? The answer is right here: it's true that the Slovene people today seem to be small, but that was not the case centuries ago. The smallness is merely a matter of belief and self-esteem. Slovenes had their giants of science and technology. Unfortunately, due to the underdevelopment of Slovenian history of science, they are somehow neglected compared to the Slovenian neighbors. The modern westerners used to write their Whig history of science full of neglecting of all other folks including the Slovenians, Chinese, Native Americans or Africans. It's high time for a change.

The idea, which flows from hundreds of our historical publications in journal Vakuunist is in its essence the promotion of self-respecting urgently needed for the Slovenes. It is an echo of the opposite directions that try to attribute the great achievements

of Slovenes to others. The fact that the Slovenian vacuum techniques and sciences are still not as good as western European or even American, is our special concern. It was not so in the distant past. At the eighth ICTF Conference in Dubrovnik, held between 13 and 16 October 2014, the professor of Material Science and Physics from Illinois University, Urbana, Joe E. Greene (Joseph, * 1944) from Arcata 280 miles north from my native Californian San Francisco described the achievements of pioneering heroes of the history of thin films. Greene runs the Microanalysis Center in Urbana, halfway between Saint Louis and Chicago as editor-in-chief of the leading magazine Thin Solid Films and former editor of CRC Critical Reviews and Solid State and Materials Sciences. These newsletters are largely intended for thin films and vacuum researchers. Thus, Greene's history narrated in Dubrovnik presented the formation of thin films designs exclusively as Anglo-Saxon achievement, with an emphasis on the greatest genius of Michael Faraday.³⁵⁷¹ Was that really the case? Did all the major discoveries really grow up at the Anglo-Saxon environment? Is the English Industrial Revolution really the mother of universal progress on a global scale? Of course not, the point is that history is written by the winners. In addition, we have that naughty rule: first come, first served. Additionally, the Anglo-Saxon winners try to impose to all others their own language as the only relevant way of communication, and in doing so, they seem to be gaining an additional advantage, since they do not waste time with learning other languages. This imposing the English language is undoubtedly the worst of them all; in fact, the lack of linguistic knowledge turn people into a spiritual poor folks without widespread insights or even visions. If the scientists of past centuries did not write in English language, they did not write anything at all because the modern Anglo-Saxon historian of science does not understand their messages! The old science historians have been enthralled by the alleged Anglo-Saxon heroes of science. Today it is very difficult to dethrone them, as the Anglo-Saxons have been published myriads of exaggerated (self) praises. Since in the 20th century the Anglo-Saxon know-how seemingly dominated its rivals from other environments and continents, the Anglo-Saxon

influential guys simply wrote the history of science to praise their own Anglo-Saxon scientific ancestors. In the background, there is, of course, great money and an extremely unpleasant severe racism: if the Anglo-Saxon scientists have always been smarter than others in the past, let them continue with such a business! Let us give them the Nobel Prizes, influential positions and recognition, while the Africans or anyone else could be a part of it only if they can come to Anglo-Saxon universities in the form of irreversible brain drain, which is in essence very like slave trade which once upon times deserted the coasts of Western and Central Africa between the 16th and 19th centuries. The westernized history of science, history of technology and even the modern research of industrial heritage used to be deeply racist and unfair to coloured and female folks.

The truth that should be published is entirely on the other side. The countries on the virtual periphery of world science, including Slovenia, the Middle East, Latin America, or Black Africa, were not lagging somewhat behind in development because their locals were above-average stupid or less able to discover or explore. They were deliberately pushed to the periphery so that now ruling scientists can continue to rule, although the ecological catastrophe of the planet Earth has long proven the wrongdoings of their rule. The history of vacuum techniques teaches us many things and even offers us guidelines for proper action: we learn pride and self-confidence of past generations led by the example of the first Carniolan vacuum researcher, Janez Vajkard Auersperg. Janez Vesel Koseski's poem from the distant Christmas of 1845 teaches us: "Remember the magnificence of the works of the dead fathers, ... who despises himself, the subjugation is to the stranger's heel."

In fact, with modern trends, Koseski's verses are becoming more and more relevant, perhaps even for experts in the field of vacuum techniques and thin films. Even if our times are rapidly changing. Yesterday, a young guy third of my age asked me what am I reading down there by the waterfalls of Sava river where Medea, Jason and his Argonauts interrupted their sailings downstream from Black Sea near their future Emona: "I read Herman Hesse, the grandson of Indologist and son of Indian born

³⁵⁷¹ Greene, 2017.

mother who introduced Indian vacuum and infinitesimal thought to westerners!” The youngster who listened to his car-producing loud techno music with his companions somewhat hesitated so I added: “You may google him...” “No, no...” he assured me “I’ll remember him, its just like Ham-and-Eggs...” Well, that’s the promising new generation, so I agreed: “Exactly, just Hesse has his s doubled...” Certainly, times they are a changing... without doubts towards the better ones?

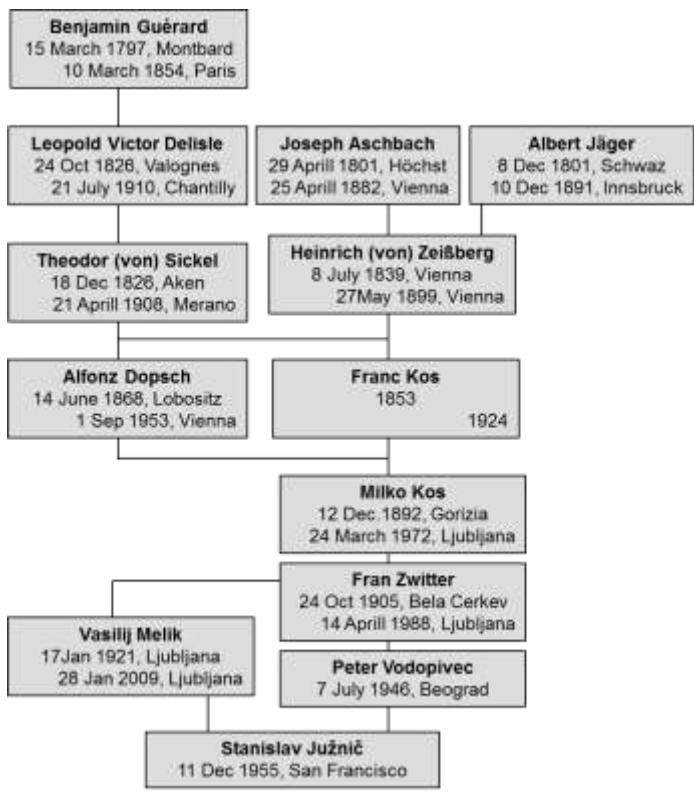

Figure 33-30: Stanislav Južnič's academic genealogy tree, following the branches of his study of the history of physics and vacuum techniques with accentuated Slovenes and underlined places of their studies. The ancestors were supervisors of the PhDs of their descendants. The picture shows the connection with Copernicus, whose book we discovered in 2006, forgotten in the dusty Ljubljana library.

34 Summary: as an Epilogue

Epilogue could be also needed. The principles of vacuum technologies can be described with a special emphasis on the Slovenian situation, as Slovenian researchers have constantly contributed significantly to its progress. The Slovenian areas raised up important vacuum theorists of the first pumps and pressure gauges. Let's repeat what we were talking about:

The research of vacuum and new materials was never exclusively westerners' domain. The empress Barbara of Celje was among the wisest designers of new materials of her era. In connection with the discovery of Copernicus' books (1566) in Ljubljana we described the vacuum research of his time. We discussed the books and instruments available to Slovenian ancestors in Copernicus' time in Carniola.

Trubar's year 2008 divided Slovenians again into "ours", and their enemies. Vacuum researchers are supposedly neutral at such kind of quarrels. It is a good opportunity to examine the opinions about vacuum and material science at Trubar's time. The opinions about vacuum at libraries of Trubar's time Carniola and Styria were researched to enlighten the scientists' lectures at Viennese, Tübingen, and Paduan Universities.

We have discovered an important contribution of the Auersperg Prince to the famous Guericke's vacuum experiments. We described the important cooperation between the prince Auersperg of Ljubljana and Guericke. Torricelli, Boyle, and Pascal's impacts were felt in Ljubljana very early. Later influence on the Ljubljana Jesuit school was primarily connected with Roman College and Bošković in his prime. We provided one of the first study of the history of physics based on the images of scientific instruments drawn in the manuscripts.

During his studies in Ljubljana College the first vacuum technology researcher from Carniola Johan Weikhard Prince Auersperg (Janez, * 1615) passed from the lower Latin Marian congregation to the higher Latin Marian congregation in 1626 which means that he just finished the study of Syntax (higher Grammar) and began his studies of Poetics.

The supposition is that he entered the school as a beginner and finished it as the student of Rhetoric. The Prince Johan Weikhard Auersperg conducted a part of his formal training in Ljubljana and continued it in Germany and Italy. Who were his teachers who guided his teenage years? Auersperg eventually finished just few years of his lower studies in Ljubljana. Who were the leaders of Ljubljana lower courses who enabled and supported the work of Auersperg's formal teachers? Who were the other important locals who helped Auersperg's formal teachers to manage his teenage aspirations? And last, but not least, who taught Auersperg's teachers?

The teenaged Johan Weikhard Auersperg studied in Ljubljana, Germany and Italy where the stage was set for the first Torricelli's vacuum experiments. Besides professors who taught Johan also his own court is discussed including his confessor Ferdinand de Montegnana who also studied in Italy and published a technical book.

The manuscripts are keys for the advancements of modern history of European vacuum techniques after most of printed sources had been widely read and interpreted. Anonymous authors' opinions on vacuum and simultaneous Athanasius Kircher's works in connection with Kircher's patron, the Prince Johan Weikhard Auersperg, provide some insight into the time of anonymous writing. Both manuscripts seem to be the product of Italian scholarship not far from the borders of modern Slovenia between Venice, Padua, and Florence, but the way they entered the Oklahoma University Collection in US is still unclear.

The first air pumps among Slovenians are discussed. The early air pumps in now Slovenian lands were put in the limelight. Did the pioneer of vacuum techniques, the Prince Johan Weikhard Auersperg, brought one of them to his Slovenian manors? Ljubljana share of early steam engines research could be proved, especially with the Jesuits Grubers in mind. Geissler's and later vacuum tubes certainly connected Slovenians and all other European nations with modern air pumps.

Several centuries lost manuscript catalogue of Ljubljana Auersperg library was examined in search

for the books about vacuum published in 17th century. The opinion and values of the authors were discussed in correlation with the library owner Auersperg's own vacuum research during his active collaboration in Otto Guericke's pioneering research. The connection between Auersperg's work for new vacuum techniques and his propaganda of the early modern science of Bacon, Galileo, and Kepler was claimed.

In Slovenian areas the erudite performed vacuum experiments already long before Geissler's glow discharges in dilute gases and Braun's cathode ray tubes were invented. The early vacuum experiments and books about them spread among the well-to-do Slovenian land people with the little help of the first Ljubljana prince Janez Vajkard (Johan Weikhard) Auersperg. The nobles, wealthy bourgeois, and monks bought and read them because they were aware of Auersperg's collaboration with Guericke on the early experiments with vacuum pump. It's hard to believe that any later exchange of the new inventions between Europe and Ljubljana was that quick, except maybe during the Napoleonic Illyrian Provinces. Therefore, we had to memorize the success of those days in public symbols of the *Slovenian Society of Vacuum Techniques*.

Books on Vacuum in the Former Cistercian Library of Sittich (Stična) were important source of local knowhow. The vacuum experiments and vacuum philosophy related books of the former Stična monastery was described. The connections of Stična library with the other libraries of today Slovenian regions were put in the limelight. The probable reasons for the Cistercian interests in vacuum techniques development were put forward. The former owner of most mathematics, physics, and vacuum related books in Cistercian Monastery Stična was the physicist and mathematician Ivan Dizma Florjančič de Grienfeld, one of the ablest literati of those days Carniola.

Capuchin's Vacuum in mid-17th century paved many ways. The most important Franciscan and Capuchin scientists connected with vacuum research were noted. Their scientific works kept in to Slovenian libraries are put in the limelight. The Capuchins Rheita, and V. Magni were considered as the most influential at today Slovene lands. The special

concern was put on books describing vacuum at Capuchin's libraries.

Valvasor's research about vacuum and thin films grinding was illuminating. Valvasor's original contributions to the development of physics and techniques are put forward in connection with his fellowship of the Royal Society of London. The special concern is put on Valvasor's library with many Robert Boyle's books included. At the other hand Valvasor bought almost all works of Boyle's opponent Kircher. He collected the Jesuit's books, most of them connected with the Kircher's Roman College circle.

Valvasor grinded a Virgin Mary statue and put it at the front of Jesuit St. Jacob's Church in Ljubljana. He described his new thin layer grinding method in London *Phil. Tran.* and in Leipzig *Acta Eruditorum*.

Valvasor followed Volf Engelbert Auersperg's example while he collected books at his own library. Volf's brother Prince Janez Vajkard helped Otto Guericke at his Regensburg experiments as the first Carniolan vacuum researcher. Slovenes later adopted Valvasor as one of their own but did not provide the same treatment for the erudite Auerspergs.

The general of Jesuits Gabriel Gruber who built Ljubljana canal and palace was very proud of his younger brother the vacuum-equipment designer Tobias. Tobias Gruber's produced vacuum equipment for conventional portable outdoors measurements. His tools became so famous that he was elected for three terms as the president of Bohemian Society of Science, the predecessor of the modern Bohemian Academy. Early in 1804 Tobias Gruber renewed his vows to the Jesuits under the leadership of his brother general Gabriel. Tobias researched in Ljubljana and in other parts of Carniola just for three or four years, much less compared to his brothers, Ljubljana professors of technical sciences Gabriel and Anton Gruber, or their mother Josefa who died in her Villa Podrožnik in Ljubljana.

The first observation of the cooling of gases during their expansion in vacuum was described. The share which the naturalized Slavic scientist the Viennese T. Gruber gave to the early research was

acknowledged with pride. We concluded our story with the usable explanation of his influences on the works of Joule and Thomson, and with the technological and industrial use of the Joule expansion in the early race for the condensation of the gases previously considered permanent.

The first vacuum experiments were carried out in Florence with the mercury from Idrija mine. Essential role in distribution of the Idrija mercury belonged to the Idrija Mine directors, especially Abondio Inzaghi and his grandson Franz Johan Inzaghi, a second cousin of the mother of Alessandro Volta. Franz Johan Inzaghi hired first-class employees. Among them were Johan Anton Scopoli, B. Hacquet, and especially the Bohemian pharmacist Ernest Freyer.

Volta's investigation of gases contributed to the progress of the Idrija mine. His relative Franz Johan Inzaghi arranged for Volta a hefty amount of Idrija mercury required for the manufacture of barometers and thermometers in Volta's new "physical theater" at the University of Pavia. Freyer used his knowledge of vacuum distillation cleaning methods for Idrija ore also to provide the good supply for Volta's classroom and for Dutch manufacturers of vacuum pumps, including Musschenbroek and Hermann Boerhaave, the teacher of many leading scholars serving the Viennese court. The consumption of mercury for scientific purposes admittedly was not great in its bulk, but it strongly contributed to the prestige of the Idrija mine. Franz Johan count Inzaghi scored his biggest success at the end of his leadership of the Idrija mine due to the huge Spanish orders intended for the amalgamation of Mexican and other Latin American ores of silver.

Because of connections with relatives Inzaghi the Voltaic electrophorus designed for multiple charging electrical Voltaic battery and gun - eudiometer for measuring air quality were extremely quickly acquired for Ljubljana higher studies' physics-chemical cabinet. Inzaghi was in touch with Volta even after his return to Graz, especially in time of Volta's wedding in 1794.

Bošković's description of vacuum and forces within it were put in the physicists' limelight of his and eventually also of our times. On 300th anniversary

of Bošković's birth his vacuum theory and two vacuum experiments connected with his name were described. One of them was Bošković's appeal for water filled telescope compared to vacuum telescopic observation of parallax, and the other was Lana's vacuum balloon versified by Bošković's Ragusa compatriot and student Brno Džamanjić (Zamagna).

Ljubljana native's books about vacuum in Brussels are noted on 300th anniversary of Johann Karl Philip Cobenzl's (Kobenzl) birth in Ljubljana. The path *per aspera ad astra* of Carniola-Gorizia family Cobenzl is described with a special attention put on their friendly relations with Ruđer Bošković and their acquisitions of book related to modern vacuum techniques. All that and much more was achieved by the next to last generation of Count Cobenzls headed by the minister plenipotentiary of Habsburg Netherlands Johann Karl Philip Cobenzl. The role of Johann Karl Philip Cobenzl's first rate Brussels library with technical-vacuum books and art collection proved to be decisive for the success of his family inside the freemasonic freethinkers' networks of Europe of his era. Although Johann Karl Philip Cobenzl never read his vacuum-related and other books but preferred his secretaries to read and comment them for him, the new books and journals helped his work in the modern times when the good and timely news paved the way for the right economic activities in vacuum and other industries of the area of modern Belgium and Luxemburg which the native of Ljubljana Cobenzl managed under the name of Habsburg Netherlands for nearly two decades.

Ljubljana vacuum technique after the suppression of Jesuit Society is described on 150-anniversary of the death of first head of Ljubljana physics-mathematics cabinet, the baron Bernard Ferdinand Erberg. The first three decades of Ljubljana high university level philosophical studies with vacuum technology inside physics-mathematics cabinet is described. For the first time in historiography Mihael Peternel's description of the preserved part of first Bernard Ferdinand Erberg's instruments accomplished a century and a half ago is used, as well as Gabriel Gruber's orders dated in 1768, the catalogues of vacuum and other instruments which Anton Ambschell signed in 1779 and 1785, the list of new

purchases between the March 1781 and March 1782, as well as A. Gruber and Schaller's catalogues. The role of Carniola Estates General and even more of Carniola Society of Agriculture and Useful Arts was decisive in material support of acquisition. From the dynamics of purchases and their maintenance we try to figure out the prevailing interests of the leaders of Ljubljana instructions of mathematical sciences in those days.

The vacuum equipment of the first Ljubljana professor of physics who wasn't a monk is put into the limelight. Although Johann Philipp Neumann came from Moravia, he unforgettably marked the development of vacuum technique in Ljubljana. His professorship in Ljubljana Philosophical Faculty with physics as its main part is described. The vacuum equipment in Neumann's care which he demonstrated to his students are put into the limelight. Neumann published his research of vacuum techniques in his textbooks and in a paper; he began publicizing just few months after he left Ljubljana. We focus on the row of his able descendants which he educated at his Ljubljana chair. On the first place Neumann's collaborators Jožef Jenko and Matija Kalister supplied him. Later Neumann sent Franc Prem from Graz as Neumann's replacement, and after Prem returned to Neumann's Graz chair Neumann's best student Janez Krstnik Kersnik was appointed in Ljubljana and kept his chairs of physics and chemistry for almost half of a century. Many archival documents about Neumann's work in Ljubljana are published for the first time in this book. Besides being a pioneer of Ljubljana vacuum techniques Neumann was also a close collaborator of the composer Franz Schubert who himself tried in vain to get a lecturing position in Ljubljana.

The vacuum balloons developed parallel to hot-air and hydrogen balloons in the 17th and 18th centuries. We were particularly interested in Vega's opinion on vacuum balloons and the problem of the modern development of such devices. The life and works of very first Slovene airman and the pioneer of ballooning is described with the early Kraškovič's effort to materialize a century and half older Lana Terzi's ideas of flight under vacuum balloons. We find the technological problems that bothered their effective use on the first place. The first Slovenian

ballooner passed away in Dubrovnik suburbs soon after New Year 1823. The complications following his testament unveil the difficulties of his personal life and even more his professional interests in vacuum techniques. Although after his higher studies he seldom visited his home country in Carniola, Slovenians should be proudly aware of his achievements.

The first vacuum research at the Jesuit school in Ljubljana was linked to the college in Rome. That is why we have specially examined the characteristics of Slovenian and the Italian environment under the influence of Guericke's, Boyle's, Torricellian and Pascal's successes. The progress of the technology was constantly accompanied by the problems of vacuum theory. Does vacuum contain anything, and what could that thing be? Like Parmenides, Descartes saw the problem of expression in his debates about the existence of an emptiness. Whether the empty glass still contains air, Descartes rhetorically asked? He preferred the "plenists" over "vacuists" to fill his world with the eddies of the ether. Newton did not like the Cartesians, and instead of the notion of ether he used the "absolute space" in his mechanics. In Fresnel's theory, which buried Newton's particle optics, ether had a real density inversely proportional to the value of the refractive index. According to Fresnel's example, many researchers were composing their theories of ether for different basic kinds of waves, while Maxwell considered that a single ether was enough. Stokes' speed of the Earth with respect to the ether varied continuously from zero on the surface of Earth to a constant at sufficiently large distances, which was by no means disliked by A. Lorentz. Einstein combined the term "ether" with the gravitational field and the "space-time" structure. Nevertheless, his theory of relativity destroyed the classical theories of the ether. Therefore, in modern physics, the term ether is no longer used except in Tesla's networks, although we present a modern swirling vacuum in exactly same way that Maxwell in 1871 represented his vortex ether. In modern theories of "everything", the vacuum has a rejuvenated central basic role; but it behaves differently, especially by our thinking about the properties of the space.

We presented the cathode rays in the middle of the 19th century as an introduction to modern techniques of vacuum thin films, especially the vacuum metallurgy. We have illustrated the competitive efforts to achieve a perfect vacuum, which of course never happened, but nevertheless paved the way for further progress, resembling the related simultaneous quest for the absolute zero temperature. Within their efforts, the researchers developed vacuum insulation and above all thermos, an indispensable tool of a modern housewife. We described the way of thinking of those times with the search for a perfect vacuum, which certainly failed, but enabled many discoveries, among them the famous thermos flask. In Edison's hands vacuum became the foundation of the modern electric light bulbs. The science turned the light on and enabled the discovery of X-rays and electrons. In the hands of the greatest inventor Edison, the vacuum has smoothened the way to modern light bulbs, which have been shining for almost a century in nearly unchanged forms. They allowed the scientists' night research and thus almost doubled their efficiency, just like the European logarithms did two centuries earlier as borrowed from Babylonians' quarter square multiplication algorithm tables and Indian mathematician Virasena's concept of ardhaccheda. Curious about what was hidden in the smallest submicroscopic objects, the German researchers developed an electron microscope. They put in the gigantic energies that promised the discoveries of new particles. People wanted to see what's behind the smallest particles and suddenly we had the electron microscope. Everybody wanted high energies and Rutherford's successors developed the first accelerators. Their research developed into ion implantation. We concentrated on the limited period from the "invention" of the ion implantation in 1905 until about 1978, when ion implants had come of age. We described the invention of ion implantation and its development until the Second World War II. We reviewed the development of the use of ion implantation for the transistor industry after the Second World War. We presented the use of ion implantation in semiconductor devices up to about 1978, when ion implants have come of age and began to be used in other areas. Special concern was put on the use of ion implantation in the metallurgy of recent times. We also described some details about the echo of the research of ion implantation

among Slovenes. Rutherford's successors have already developed the first accelerators. From their research, ion implantation was designed. Between 1905 and 1978, it developed into a mature form of technology. Its main success was the transistor developed in my native Silicon Valley, which quickly became established in Slovenia.

We discussed the life and research of J.J. Thomson, a famous leader of the Cavendish laboratory. His key contribution in the "discovery" of the electron is described. His relations with contemporaries that made him discover the "electron" for the generations to come are described. We also analyze Thomson's research of "positive rays". The echo of his successes among Slovenian contemporaries is mentioned. The detection of X-rays and electrons crossed the threshold of modern science. Among the most successful vacuum technology users was the "discoverer" of the electron J. J. Thomson, the renowned director of the Cavendish Laboratory. We summed up Thomson's research on "positive rays" and the echoes of his discoveries among his Slovenian fans.

The investigation of the bombardment of atoms with electrons triggered complications which prompted the discovery of Auger electron spectroscopy. We have investigated the early results of bombarding matter with electrons. The most interesting were the events surrounding the discovery of Auger's spectroscopy, also connected with one of the first successful female researcher scientist Lise Meitner. We were interested in the first successes of the then researchers, especially the lovely Jewess Lise Meitner. We explained why a lot of time has elapsed before the Auger spectroscopy was successfully introduced for industrial purposes. We showed how they met the needs for measuring the properties of industrial thin films in recent decades. We have listed the strong sides of Auger's method in modern industry. We highlighted the advantages of modern Auger's spectroscopy and mentioned the fourth decade of its use in Slovenia. The special concern was put on the application of Auger's method in Slovenia.

We summarized the development of plasma research, probably the most promising among the modern vacuum technologies. Overall view gives us

some insight in the past also in the future of our industrial world. We have shown that the vacuum really was once the second term for nothing, but today it indeed links almost all the technical achievements around us. Sputtering the thin films on the walls of the tubes and sputtering the cathode initially disturbed the researchers for almost a century, and then turned into the most promising forms of modern technologies. We emphasize the Slovenian contribution to vacuum technology from the Auersperg prince to modern successes.

The end of the First World War brought the foundation of the long-awaited renewed University of Ljubljana. Among the first professors, the important vacuumists were installed there in the departments of physics and chemistry and later at the Institute of Electrical Engineering. Among them were A. Klemenc and Hugo Sirk of the Slovenian genus. Sirk experimented with radioactive thorium in cathode ray tube and with plasma in a magnetic field before the First World War. In 1928, he took over the Department of Physics at the University of Ljubljana from his four-years-younger inventor Nardin. In the Slovenian metropolis Sirk studied X-rays. In Ljubljana, he proved to be particularly interested in exploring the magnetic effects of X-ray scattering with the help of Anton Peterlin.

Some people were rich and wanted to have fun. People love entertainments and Slovenian Codelli invented the television, although, finally, his American competitors won the prizes. We are special proud to claim very important Slovenian contributions to the past development of vacuum technology. And we are even more proud that the research continued in the fertile directions in this small but effective middle European land. The Slovenian Codelli and Russian emigrants in America developed television for all of us. Baron Anton Codelli was the first to use the cathode-ray electronic television on Slovenian soil to be able to spread his European patents to the US. Therefore, in addition to mechanical scanning and mobile optical devices, his third option was described entirely by electronic television without movable mechanical parts. In the electronic version, he also retained the basic idea of recording and receiving the image along the spiral so that the image had denser elements in the middle than on the edges.

At the Ljubljana Institute of Electrical Engineering, Vladimir Šlebinger assisted Marij Osana between 1933 and 1935 after he abandoned television research at von Ardenne's lab in Berlin. From the television and computer screens, Slovenian inventions always watched us. The cathode-ray tubes in the screens were or still are, immediately behind the bulbs and thermos, one of the most long-lived vacuum products, which obviously do not intend to withdraw from the market completely anytime soon. In any case, we have incorporated many important Slovenian achievements into modern vacuum technique, which we are reasonably proud of. The book deals with the development of vacuum technologies with a special concern put on the Slovenian researchers.

Cauchy's Vacuum Theories in Gorizia were among the best Slovenian areas ever produced. The early development of vacuum enterprises Leybold and Heraeus in German part of the Middle Europe is discussed. Their success followed the most important achievements in the research of the vacuum theory at the border of Slovene Middle European lands that Cauchy accomplished in Gorizia in the years 1836-1838. By using French and Italian archive sources we describe Cauchy's life and work in Gorizia for the first time in historiography. We discuss the main Cauchy's scientific collaborators in Prague, Vienna, Graz, Ljubljana, and Gorizia. Cauchy's work considerably influenced the later development of central European vacuum research from Balzers to modern Slovene inventions.

The Early Japanese Vacuum Techniques developed from the great far-eastern traditions. The vacuum pumps entered Chinese court in Hallerstein's time, but eventually received less interests compared to the Western astronomy. One of the reasons for the Chinese doubts was the nonexistence of the broader scale technical use of vacuum or electricity during the Hallerstein's lifespan. The vacuum and especially Leyden jar research entered even easier the Japan of Hallestein's times when only Dutch and Chinese had some Japanese trade privileges, because at least the Leyden jar was essentially Dutch invention.

Slovenian-Croatian vacuum and related instruments exchange in Illyrian Provinces was introduced by

Raffaella Zelli (Zell, * 1772; † 1817) who was professor of mathematics and physics in Zadar. In 1808/1809 he was appointed the director of Zadar Lyceum and at the same time he became the personal chemistry tutor of the duke of Dubrovnik marshal Auguste-Frédéric-Louis Viesse de Marmont (* 1774; † 1852). Marmont got the prestigious job of the Governor general of Illyrian Provinces and took Zelli with him to Ljubljana. Zelli became the supreme inspector of all public schools. In Ljubljana, both became frequent visitors of Žiga Zois' (* 23. 1. 1747 Trieste; † 10. 11. 1819 Ljubljana) house where they discussed vacuum and Voltaic experiments. Many vacuum and other books from Ljubljana Lyceum libraries were shipped to Zadar to help the Zadar Lyceum. Marmont established his excellently equipped laboratory in Ljubljana Bishop's house where he staid between 16. 11. 1809 and the beginning of the year 1811. Upon his farewell he donated all his equipment to Janez Krstnik Kersnik's (* 26. 3. 1783 Moste by Žirovnica in Upper Carniola; † 24. 6. 1850 Ljubljana) physics-chemistry Cabinet of Ljubljana Central schools. Among his gifts were fine analytic balance, Voltaic pile capable of 100 V, Galvanic battery with 100 elements copper-zinc, distillation apparatus, and many other vacuum related instruments. Marmont certainly learned a lot from his Zadar tutor Zelli and their support of the Ljubljana school laboratory could be described as the very first successful collaboration between Croatian (Zadar) and Slovenian (Ljubljana) vacuum researchers. In 1811, Kersnik inventoried his laboratory equipment. Some of his vacuum and other instruments selected by the present author were displayed in the exhibition in Ljubljana city museum opened by the president of France on May 11, 2009.

The main points of Napoleonic governmental changes influencing Zois's vacuum science and Kersnik's education in vacuum techniques were put in the limelight. French revolutionary novelties accompanied the dismissal of last tracts of the Jesuit's centennial education of physics and mathematics at Ljubljana higher philosophical studies. The main points of the life, lectures, and scientific works of the Ljubljana professor of physics and mathematics serving in the Illyrian Provinces are put forward, most of all Gunz, Kersnik, and their learned friend, Zois. The lists of their scientific-didactic vacuum equipment were provided. The

relations between the leading literati of those days Ljubljana is given, including Nodier, Vodnik, and Ž. Zois. Their relations with the vacuum researchers of their capitals is given, the old one at Vienna including Jurij Vega, and the new one at Paris including Lalande, Laplace, Lagrange, or Biot. The relevant sources for Gunz and Kersnik's work at Ljubljana are their mathematical books and Kersnik's vacuum didactic school equipment.

The special attention was put on the schools at Gorizia, Trieste, Koper, and Zadar. The destiny of Napoleon's scientific ancestry at Slovenian lands was researched with the surprising conclusion that the Restoration brought almost no changes, because the Ljubljana professors of science kept their chairs also under Metternich's regime to support the poetical thoughts of Gunz' student, Jovan Vesel Koseski: »The changes are only damages, just few of them remain«. The absence of changes resembled the similar situation four decades earlier after the suppression of Jesuitical order while the reasons for that curious fact were again the same: there were so few technically trained professors in European peripheral towns that any ideological purges were out of the question until the culminations of ideological apartheid in 20th century.

Zois' circle is the key for understanding of the Illyrian provinces knowledge about vacuum in Napoleon's era. Zois' vacuum steel producing enterprise was compared with Kersnik's notes of his school inventory. We examined all preserved catalogues of Zois' library with care. Zois' scientific readings were compared with Valvasor's, Erberg's, Auersperg's, Lyceum's, and other libraries of the era. Gruber's influence on Zois' book taste was proved including Zois' passion for Jesuit Bošković, Franklin, and Newtonian science. Zois' acquired minerals and books under the influence of his previous close friend, Hacquet. Hacquet also advised Zois' ordering of the numerous scientific journals dealing with vacuum research. Vodnik's collaboration with Zois is reflected at Zois' literature on vacuum, which helped Zois and Vodnik on their invention of the Slovene Natural Sciences terms. Besides well-known Kalister-Korn's selling catalogue of Zois' books at NUK, the earlier probably Kopitar's (1803?), Schober's and Zupan's

catalogues on unbound sheets kept at ARS were also used.

The overview of Tesla's vacuum technique makes nice anniversary of introduction of the unit tesla. Nikola Tesla was born century and a half ago as one of the best researchers of vacuum discharges. Tesla's quarrel with the famous J.J. Thomson was described in some detail. His scientific and other connections with Slovene lands were put in the limelight. The claim was forwarded about the high quality of Tesla's predecessors and contemporaries from Slovene lands.

Franz Hočvar was the most successful scientist from White Carniola. His main works belonged to mathematics, but he also published several physics papers about electrical experiments using the modern vacuum technique. He used innovative techniques in his pedagogical achievements and considerably improved vacuum technology of his times with the early use of the Geissler's vacuum tubes in the electrophorus.

The Slovene female physicists recently entered research of vacuum techniques. In the year of physics, the contributions of Slovene female researchers in vacuum techniques were described. The achievements of Hertha Ayrton in arc light research were mentioned. After historical introduction we described the success of Serafina Dežman († 1896) at her measurements of pressures with barometers and other experimental techniques in Ljubljana. She was trained by her brother Karel Dežman as his collaborator and after his death she continued the experiments on her own. She could be considered the first important modern Slovene female experimental physicists, working in the field of barometer techniques, and using sophisticated vacuum barometers already 150 years ago.

Marija Wirgler was the first Slovenian female professor of physics, and Ángela Piskernik was the very first Slovenian girl with Ph.D. in natural philosophy. In their time the University of Ljubljana was established with better opportunities for Slovene female researchers. Emilija Mlakar, married Branz as the very first woman took over a mathematical sciences degree at the University of Ljubljana in 1928.

After the Second World War many Slovene women entered the field of physics research with the use of vacuum techniques. One of the first was Snegulka Detoni, famous for her work on vibration spectrums. After her diploma and dissertation at Ljubljana University Bibiana Dobovišek, married Čujec, began her pioneering work (1955-1966) on the new betatron at Nuclear Institute, today Institute Jožef Stefan in Ljubljana. Danica Burg-Hanžel, as the very first Ljubljana female engineer of physics, became the leading researcher of the Mössbauer's spectroscopy.

Peterlin contributed to the development of vacuum technique. Many Peterlin's family members published about science and vacuum, among them his wife's grandfather Maks Samec the elder.

As a young assistant at the University of Ljubljana Peterlin used early vacuum techniques for the measurement of X-rays scattering on liquids. His wartime work in Dresden brought him increasingly in contact with macromolecules which became his main area of research. During his decade-long leadership of Ljubljana Physics Institute, in the meantime named after Jožef Stefan, Peterlin introduced modern vacuum techniques in nuclear and solid-state physics, thereby providing a solid foundation for our present days' achievements. Within the quarter century at the University of Ljubljana (1933-August 31, 1960), first as assistant and later as a full professor, Peterlin educated the whole post-war generation of Slovenian scientists, physicists as well as mathematicians. For over a decade he did not only taught experimental physics but also designed and supervised laboratory experiments for students using vacuum techniques.

Accelerators and thin films were at the shadow of (Yugo)Slovenian A-Bomb. Peterlin's managing of Jožef Stefan Ljubljana Institute in 1949-1959 could be comparable with J. Robert Oppenheimer's (* 1904 New York; † 1967 Princeton New Jersey) work in 1943-1954. Oppenheimer had General Groves and Senator McCarthy, but Peterlin eventually had to deal with Yugoslavian Communist authorities. In his pursuit to grant more money for his macromolecular research Peterlin had to accept the opportunity to build the nuclear institute at Ljubljana, but after a decade of hard work he faced a

similar destiny as Oppenheimer did five years earlier. During his Ljubljana work Peterlin was able to develop the accelerator and thin films research. He enabled Slovenian modern achievements at that fields.

Nanotubes paved their own way. The contemporary Ljubljana discovery of the special sort of mono-crystal MoS₂ nanotubes connected the older traditions of the Molybdenum and Tungsten manufacturing, and most of all it continued Hacquet's observation of the tube-like crystal structures.

Hacquet's frostwork hard rime research was a part of the numerous small advancements in science published from somewhat personal letters that connected the central European researchers to a kind of old world web. Hacquet performed his research simply on the window of his study-room. He measured with a barometer, thermometer, and microscope. He pioneered the use of microscope in crystallography by combining his crystallographic experiences with many years of his floristic observations. His result was quite modern description of the icy ferns' crystal growth. Hacquet's crystallography influenced later purchases of scientific instruments in Ljubljana and modern research of crystals that eventually lead to the discovery of modern inorganic nanotubes in Ljubljana.

The Ljubljanese invention of dr. Remškar went through their hardest times up to the limelight, *Per Astera Ad Astra*. The support from Switzerland should be considered decisive as Swiss traditionally for a century and more supported the female scientists from Slavic countries. The success of the Ljubljanese researchers could be compared with the achievements of Japanese and Israeli researches in the field of nanotubes.

The structure of MoS₂ nanotubes is described with a possible explanation of the novelty they bring into the new geometrical approach to chemistry. We tried to predict the future development of that promising technology.

For over dozen years Osredkar headed the Jožef Stefan Institute in the crucial era for the development of Ljubljana technology of thin films,

which Boris Navinšek began to develop with his first »table« ionic bombardment instrument during the early years of Osredkar's directorship. Osredkar got his Masters' degree in New York, and after his Ljubljana dissertation held a position within Viennese International Atomic Energy Agency. Through his connections with foreign experts Osredkar got excellent overview on contemporary vacuum techniques and possibilities for their use in Ljubljana. We discussed early Osredkar's steps from the pre-war electro-technique into post-war physics which enabled previously unthinkable development of vacuum techniques in Slovenia.

On occasion of the premature death of the Academician Robert Blinc his contributions for the development of the modern vacuum techniques in Slovenia are put in the limelight. As the head of condensed matter physics department of Institute Jožef Stefan professor Blinc employed the leading experts for vacuum technology and in that way contributed to its development.

Blinc employed his vacuum technology for food industries especially by NMR detecting the content of water in stored seeds of sunflowers. The storing of food is essential for the history of nutrition. The vacuum can remove the oxygen needed for the development of beings harmful for food. We protect the contents of flasks from external temperature effects or eliminate water from the frozen food. While the first deoxidation method was invented soon after the invention of the vacuum pump three and a half centuries ago, a thermos flask helps to keep the food barely during a century. The lyophilizing drying was very well-developed during the time of troubles of the Second World War as revitalization of Native American designs.

The vacuum protection was used for the first time for the storage of grapes and the obtained wine. Two and a half centuries later, thermos flask began to be used quite differently for the storage of brewed milk. The grapes and milk were first successfully stored by Germans, grapes, of course, with substantial assistance of Žužemberk-born prince Auersperg. The natives of Suha Krajina including Žužemberk in Carniola have always been first-class experts for grapes. The well-to-do Englishman Boyle stored wine in a vacuum recipient for the first time. As

expected, he rejected the local products and used the French noble drops of wine. Or he even imported some Slovenian drinks?

A century ago, Ernst Mach passed away. His parents and sisters managed a farm under Gorjanci 25 km southeast of the native place of first prince Johan Weikhard Auersperg. E. Mach was a student of Andreas baron Ettingshausen and designed the pioneering use of photography for ultrasonic projectiles. Peter Salcher, the student of K. Robida, S. Šubic and A. Toepler, made the measurements based on Mach's ideas. Robida was one of pioneers of cathode sputtering. Ettingshausen and Toepler developed the modern scientific photography. Both achievements are today used to make ultra-speed photographs of thin films sputtering with the magnetrons.

The vacuum is not only a tool for storage, but already for half of a century is also a medium for cooking. Rumford in Munich was the first European to announce a long-term cooking at low temperatures already used for a long time in elevated posts of Native Americans and Indic inventors. Although Rumford was an American-Englishman in the Bavarian service, the modern-day cooking processes in a vacuum at temperatures below the boiling point is popularly known with the French name *Sous-vide* maybe also because Rumford spent his last Parisian era as the unhappy estranged husband of Lavoisier's widow.

Many of the most important Slovenian and Croatian vacuum researchers were at home in the Upper Kolpa Region where 22nd Croatian-Slovenian meeting on vacuum techniques took place in 2015. Among them are Janez Kovač (Srobotnik), the first writer of the post-war Slovenian physics textbook Franc Kvaternik (Osilnica * 1919; † 1981), Matjaž Panjan and his uncle Peter Panjan (Sodevci). The present writer from nearby Fara was commissioned to describe their achievements. An interesting regional fact is explained by the extraordinary technical heritage of the population of Upper Kolpa Regions, beginning with the local medieval mills. In 1651 forges processing of Carniola iron ore was set up by Count Peter Zrinski in Čabar. The products were exported by the harbor of Bakar. The 19th

century immigrants from Slovenian side Aleksander Vilhar (* 16/2/1814, Planina 74 by Rakek; † 1868) and Wilhelm Vilhar, the brothers of famous poet F. Levstik's friend Miroslav Vilhar (Wilicher, * 1818 Zgornja Planina 74 by Rakek; † 1871), produced one of the first Croatian saw steam powered using vacuum techniques in Milanov vrh between Čabar and Prezid by Croatian side of Upper Kolpa valley in the year 1847/48. Aleksander's grandson Dušan Vilhar (* 1867; † 1913), friend and collaborator of Croatian national hero Fran Supilo, designed a steam sawmill based on more modern vacuum techniques in nearby Gerovo. The physicist Franc Kvaternik examined it there. His home was just few miles on the west across the Kolpa River. Considering the UNESCO year dedicated to light and related technologies, modern optics-related designs of vacuum researchers descending from the banks of the Upper Kolpa in the field of optoelectronics, luminescent materials and optical properties of thin films were put in the limelight.

Zelli's tutoring of Marmont, Vilhar's enterprises in Gorski Kotar and the work of the Orthodox Nikola Tesla from Croatian Vojna Krajina in Maribor (1878–1879) were the earliest collaborations among the Croatian-Slovenian experts in vacuum technologies, and many more followed including the modern 22nd Croatian-Slovenian meeting on vacuum techniques in Osilnica. Despite the March 1879 Tesla's prosecution from Maribor to Gospić, Tesla transferred the vacuum techniques of his Karlovac (Rakovac) professor the Zagreb academician Martin Sekulić to Maribor. In Maribor Tesla tried for the first time to imagine Sekulić's ingenious laboratory experiments with cathode ray tubes to industrial applications on greater scale. Tesla Coil, especially the one in Wardencllyffe tower, was the largescale application of Sekulić's school laboratory Rakovac by Karlovac designs. It was expanded in Tesla's Maribor dreams to the scale never imagined before to bring electric light and energies to everybody. The due respect is paid to Tesla's Maribor whereabouts which developed somewhat clumsy youngster Tesla into a greatest of all men.

The development of vacuum technologies based on Toynbee-Kuhn-Južnič's model in a five-step scheme is illustrated. It focuses on three major inventions: vacuum mercury barometer, air pump, and

Geissler's discharges leading to cathode ray tube. Especially the last one turns out to be one of the most influential inventions of all times. For conclusion, the projection of future development of vacuum techniques is given under the guidance of new incoming research powers. The future contributions of non-white researchers of vacuum technologies will join recently advanced vacuum techniques researchers from middle-class, rural, and female environments. On the UNESCO's year dedicated to light and involved technologies a graph is published showing the development of physical optics focused on vacuum technologies.

After three decades of writing for DVTS journal *Vakuumist* with the first hundred published papers and three monographs published for DVTS, it is time to look across the shoulder on the accomplished path and achieved results. The experiences will provide good signposts for younger Slovenes who wish to become vacuum-related scientists.

Our European academic ancestors developed or borrowed from Easterners most of the basic experimental tools of modern physics during few decades torn apart with religious wars of the first half of 17th century. In a row the European scientists began to use the new microscopes, telescopes, thermometers, movable Chinese clocks, balances, barometers, and also the vacuum pumps as the most expensive and most revolutionary of them all. After the measurements with those new-invented tools, some of the fundamental variables of physics proved to be limited in one directions, the others were restricted in both directions by their smallness and greatness, and the rest do not have the real limits at all. The vacuum technologies are among the first or inside the second group because the perfect vacuum proved to be unreachable in the form of total emptiness while the greatest pressures-densities do not seem to have any proved limits eventually depending of currently prevailing theory of astrophysics or particle physics or both. The centuries of European problems with nothing, vacuum, and similar limits were the products of uncritical European borrowing of those ideas from the very differently shaped Indian sciences during the last millennia. The Europeans used the novelties for the developments of their newly shaped technologies which brought profits. They were

willing to leave to Indian literati the deeper theoretical knowledge which did not offer any immediate surplus of western money. For that reasons the modern Western vacuum technologies just slowly influence the everyday thinking and debates among the ordinarily people who in their own way try to influence the decisions about the support and financing of scientific research. The common Europeans were never systematically trained to understand anything fundamental about vacuum in contrast to their India native peers. The lack of understanding of basic theoretical questions as is "what is missing in a vacuum" in that way obstacles the desired greater financial supports for more widely understandable vacuum technologies which could please narrowminded financial elites. The modern Copenhagen Manhattan interpretation of quantum mechanics which does not try to be understandable even to the experts, was probably one of the reasons why the bulk of the research money recently passed from the research in physics to the research of genome which with its twenty-three chromosomes offers much more reasonable visions even to the uneducated lay people. The transfer of research money brought no fatal blows to the developments of the vacuum technologies which retained their basic positions in the fundamental research of physics, as well as in nanotechnological experiments on genomes.

35 Keywords

Count Johann Karl Philip Cobenzl (Kobenzl), Ljubljana, Brussels, 18th Century, 17th century, Athanasius Kircher, Torricelli, Abondio Maria Inzaghi, Ernest Freyer, Count Franz Johann Inzaghi, Alessandro Volta, Idrija, Ljubljana, Pavia, history of Vacuum Technology, Brno Džamanjić (Zamagna), Ruđer Bošković, History of Astronomy, History of Aeronautics, History of Air Pumps, Slovenia, Steam Engines, Vacuum Tubes, Athanasius Kircher, Ferdinand de Montegnana, Ljubljana, Tobias Gruber, Gabriel Gruber, Vacuum Based Measurement Devices, Jesuits, Baron Bernard Ferdinand Erberg, Anton Ambschell, Mihael Peternel, Carniolan Society of Agriculture and Useful Arts, Johann Philipp Neumann, Franz Schubert, Pioneer of Ballooning Gregor Kraškovič, History of Ballooning, Bloke of Inner Carniola, Vienna, Ragusa, High-speed cameras, Ernst Mach, Peter Salcher, plasma sputtering, magnetron, Milan Osredkar, Jožef Stefan Institute, Vacuum and Nuclear Techniques in Mid-20th Century, Robert Blinc's Obituary, Liquid Crystals, Nuclear Magnetic Resonance, Flask, Lyophilisation (Freeze-drying), Cooking *Sous-vide*, Otto Guericke, Robert Boyle, Benjamin Thompson count Rumford, Nikola Tesla, History of Technological Achievements of Osilnica and Upper Kolpa River Regions, Vilhar, optoelectronics, optics of thin films, Public Opinion about Sciences, Founding of Research, DVTS, Leybold, Heraeus, Balzers, Cauchy, Gorizia, Hallerstein, Beijing, Japan, 18th Century, Jesuits, Electrophorus, Air Pumps, Franz Hočevar, Metlika in White Carniola, History of Vacuum Technology & Science, History of Electricity, Janez Vajkard (Johann Weikhard) Auersperg, History of Libraries, Zelli, Zois, Marmont, J.K. Kersnik, S. Gunz, V. Vodnik. C. Nodier, Slovenian lands, Illyrian Provinces, Napoleon, discharges, Slovenia, Female Physicists, A. Klemenc, Hugo Sirk, Anton Peterlin, Maks Samec, Jožef Stefan Institute, Ljubljana, Dekleva, Navinšek, Accelerator, Thin Films, A-Bomb, Ljubljana, Nanotubes, Ljubljana Prince's Library, Ivan Dizma Florjančič de Grienfeld, History of Libraries, Sittich Cistercians, Franciscans, Capuchins, Rheita, V. Magni, Valvasor, History of Thin Films Technology, Gruber, Joule Expansion, Joule-Thomson Cooling.

36 Acknowledgements

Thanks for their your help and advices goes to dr. Boris Golec, Leopold Mikec Avberšek, Dejan Kac, dr. Bruno Besser, dr. Damjan Bojadijev, mag. Andrej Pregelj, dr. Vincent Nemanič, dr. Peter Panjan, dr. Janez Kovač, and Bratislav Stojiljković.

We would like to thank the Public Agency for Research of the Republic of Slovenia (ARRS), the Society for Vacuum Technology of Slovenia (DVTS), University of Oklahoma, and many others.

37 Literature and Sources

37.1 Unpublished Archival Sources with their Abbreviations and Cities

ARS, AS = Archive of Republic Slovenia, Ljubljana.

SI_AS 1 Vicedomski urad za Kranjsko (Vizedomamt für Krain, Viceroy's archive in Carniola) 13th century-1747

- box 181, fasc. I/102: 20 September 1596 letter of Gregor Corissa from Ljubljana sent to the emperor Ferdinand and to a viceroy in Ljubljana.
- Cerkevne zadeve (Church Matters)

SI_AS 2, Deželni stanovi za Kranjsko (1457-1861) (Estates general for Carniola's archive), Fascicles 54/7 and 98

SI_AS 6, Reprezentanca in komora za Kranjsko v Ljubljani (Chamber and Representation for Carniola in Ljubljana) (1747–1763)

fasc. 40, Technical unit (Tehniška enota, box) 121, I map (mapa)

SI_AS 7, Deželno glavarstvo za Kranjsko, politični oddelek (Provincial government for Carniola, political department) 1260-1786

- Ecclesiastica (Church Matters), Litera A, Numero 8 Volume 1, Technical unit (box, Tehniška enota) 212, Ambschell Priesters Beschuldigung/wegen Verschiedener In-Briefen. Acta de annis 1782, 1783
- SI AS 7/XI Ecclesiastica A, Litera J, Numero 23, Volume (zvezek) 1, Technical unit (box, Tehniška enota) 533, Report of the commission handling the property of former Jesuitical society noted on 29 November 1773 and 1774 (poročilo komisarjev)
- SI AS 7/XI/225/1 (old reference code AS 7, Eccl. J-4-2) Jezuiti na Kranjskem, razpustitev (Jesuiten Ordens Aufhebung, Suppression of Jesuits in Carniola) 1773-1773
- SI AS 7/XI/225/2 (old reference code AS 7, Eccl. J-4-3) Jezuiti na Kranjskem, razpustitev

(Jesuiten-Ordens Aufhebung betr(effend), Suppression of Jesuits in Carniola) 1774-1775

- SI AS 7/XI/226/1 (old reference code AS 7, Eccl. J-5-1) Jezuiti na Kranjskem, razpustitev (Jesuiten-Ordens-Aufhebung, und Liquidirung dessen Activ- und Passiv-Standes betr(effend), Suppression of Jesuits in Carniola) 1773-1780
- Rubrica Publico Politica, Litera S, Numero 19, Volume 6, Technical unit (box, Tehniška enota) 72, Acta de ann. 1778
- Rubrica Publico Politica, Litera S, Numero 19, Volume 9, Technical unit (Tehniška enota) 73

SI_AS 11, Komisija za fevdne zadeve, box 23, Urbar (tax register) Kočevska Reka 1498 (cited as Urbar 1498)

SI_AS 14, Gubernij in Ljubljana, Registratura III, Fascicle 46, 1801–1806, box 364

SI_AS 33, Deželna vlada, konvolut 455, Technical unit (Tehniška enota) 182

SI_AS 309, Legacy inventories of Land Court in Ljubljana, 1544-1813 (Zbirka zapuščinskih inventarjev Deželnega sodišča v Ljubljani):

Legacy Inventory of Maria Theresa Wintershofen married Oršič, fascicle 39, technical unit 77, litera O, no. 1-8;

Legacy Inventory of Franc von Ott (Otto), fascicle 39, technical unit 78, litera O, no. 10;

Legacy Inventory of Janez von Pučar upon his death, fascicle 34, Technical unit 81, litera P, nos. 29-42;

Legacy Inventory of Petteneghk in Ljubljana, 23 January 1705, fascicle 35, box 85, litera P, no. 75, pp. 1–144;

Legacy Inventory of count Georg Andrej Triller von Trilleck (Inventarium über Weylandt wohlgebornen (wailandae vollgebornen) Herr Herr Graf Georg Andrej Triller von Trilleck), fascicle 46, Technical unit 114, litera T, no. 25a/Ribnica, pp. 155–206.

SI_AS 533 Kmetijska družba v Ljubljani, 1767-1945 (Landwirtschaftsgesellschaft, Agricultural Society of Carniola in Ljubljana)

Ambschell, Anton on 7 November 1785. Agricultural Society of Carniola (Kranjska kmetijska družba, KKD), Spisi, Statut 1780–1820, Initial unpagged documents

SI_AS 730. ER= Erberg, Jožef Kalasanc. 1798. Jožef Vode's Library numbers and alphabetical catalog entitled: Verzeichnis der Bücher in der freiherrl(ichen) Erbergischen Bibliothek am d. J. 1798. SI AS 730, GrA, Lords of Dol (Lusthal), Books 17 and 18

SI_AS 791 Manor Turn by Ljubljana River, 1597-1944 (Fund / Collection), Codelli, baron Anton von Fahnenfeld. 1929-1935, Gr A XVIII, boxes 19 and 20 (cited as: Codelli, AS):

Arco, Count Georg Wilhelm Alexander Hans. 28 January 1908. Letter to Codelli from Berlin to Ljubljana. 4 pages. (Codelli, box 20).

Arco, Count Georg Wilhelm Alexander Hans. April 23, 1908. Letter to Codelli from Berlin to Vienna. 3 pages. (Codelli, box 20).

Arco, Count Georg Wilhelm Alexander Hans. 15 September 1930. Letter addressed to dr. Carl Schapira of Telefunken. 2 pages (Codelli, box 19).

Codelli, Baron Anton von Fahnenfeld. Letters to Arco on 12 January 1908, undated (February-March 1908) and on 20 December 1927 (Codelli, AS, p. 14). (Translated by Albin Wedam in: 1977. *Dokumenti Slovenskega gledališkega in filmskega muzeja (Documents of the Slovenian Theater and Film Museum)*. Ljubljana. 13/29: 118-121).

Codelli, baron Anton von Fahnenfeld. 14 November 1928. Letter to Fritz Schröter. 9 pages (Codelli, AS box 19).

Codelli, baron Anton von Fahnenfeld. 17 January 1930. Patent specification, German typescript, and English translation on 15 pages with 17 patent applications on 5 pages and 6 sketches on 2 pages (Codelli, AS box 19).

Codelli, baron Anton von Fahnenfeld. around 26 April 1930. 60 pages long English typescript with 62 patent applications on a further 20 pages (Codelli, SI_AS box 19).

Schapira, Carl, Letter to Codelli on 20 July 1929 (Codelli, AS, box 19).

Schröter, Fritz Georg Ernst, Letters to Codelli signed on 27 October 1928, 31 October 1928, 20 November 1928 and 14 March 1930 (Codelli, SI_AS box 19).

SI_AS 854. Archive of Republic Slovenia (AS), Private Archive of Karel Dežman, fasc. 854, boxes 15, 16, 17, 18, 19, 20.

SI_AS 863 Freyer, family (rodbina), 1683-1864, 19 boxes:
box 3, *Beschreibung meiner im Besitz habende Bücher* 29 April 1790 (Freyer's books)
box 19 Freyer's books, 25 January 1835, nos. 55, 56

SI_AS 1052, Zo = Zois, Žiga. 1803?. catalogs of books written on unbound sheets, Posebno udejstvovanje (Special accomplishments, activities):

fasc. 19: Katalog der Bücher, die sich in der Bibliothek der Herrn Baron Sigismund Zois Freiherr von Endelstein befinden. Jernej Kopitar's catalogue of Zois' books listed about 1804 during Kopitar's work in Zois's library in 1803-1808 as used by Kidrič in 1939 probably lost while moving from Rudolphinum (later Narodni Muzej) to ARS some 100 m to the south in Ljubljana. Might contain also Zois's catalogue of 1812 during Jakob Zupan's work (Kidrič, 1939, 34; Svoljšak, Vidmar, 2019, 19, 92, 97).

SI_AS 1052, fasc. 20: Katalogi (Catalogues) = Zois, Karel & Zois, Žiga (Svoljšak, Vidmar, 2019, 17).

SI_AS 1063, Collection of Documents (Zbirka listin).

SI_AS 1073, Collection of manuscripts (Zbirka Rokopisov):

Diarium Patri Ministri as the diary notes of Ministers of Jesuit College in Ljubljana:
I/32r (noted by the Jesuitical Minister Pavel Gašperšič (* 1601; SJ; † 1672) from January 1, 1651 to 1658);
I/37r (from 1712 until 1721);
I/38r (from 1722 until 1736);
I/39r (from 1737 until 1754);
I/40r (from 1754 to 1772, including the notes of the minister Erberg, Bernard Ferdinand on 9 March 1758).

SI_AS 1073, Collection of manuscripts (Zbirka Rokopisov), II/51r, *Sodalitas Beatissimae Virginis Mariae in Coelos Assumptae in Archiducali Collegio Societatis Jesu Labaci Erecta et Inchoata anno M.DC.V. Confirmata M.DC.VI Duarum Mater Sodalitatum; Vnius sub titulo Im[m]jac: Conceptae M.DC.XXIV. Alterius sub titulo Natae Reginae Angelorum Custodum M.DC.XL. Curavit hoc Album Sodalibus inscribe[n]dis M.DC.LI, Confirmationis suae XLV*, notes dated 1605–1782.

SI_AS 1073, Collection of manuscripts (Zbirka Rokopisov), II/52r, *Bruderschaft der Unbeflechten Empfängnis unserer lieben Frauen alda zue Laybach; Sodalitas Beatissimae Virginis Mariae sub titulo Immaculatae conceptionis*, notes dated 1624–1783.

SI_AS 1073, Collection of manuscripts (Zbirka Rokopisov), II/53r, *Matricula illustrissimae congregationis procerum Carnioliae sub titulo (Sodalitas) Christi in cruce agonizantis anni MDCXX inchoatae et XI augusti anni eiusdem ab Admo. R. P. Mutio Vitellesco (Vitelleschi, the sixth Superior General of the Society of Jesus) Societatis Jesu praeposito generali erectae et confirmatae*.

SI_AS 1073. Collection of Manuscripts, 149 r: Raigersfeld (Rakovec). Baron Michael. 1763. Annotationes ... Accomodata ad Compendioria Physicis Patri Pauli Mako S.J.; Philosophia in Alterum year Auditor sub Professor R. P. Joanne Schottl In Collegio Regio Theresiano.

SI_AS 1073. Collection of manuscripts. 180 r: Historia annua Colegii Societatis Jesu Labacensis (1596-1691).

SI_AS 1073. Collection of manuscripts 242 r: Erberg, Bernhard Ferdinand. Around 1740. Physics.

SI_AS 1961 – 85 of more than 1000 boxes moved on 18 December 2003 from archive IJS at Podgorica to the archive of republic Slovenia (ARS), Zvezdarska 1, Ljubljana.

Škofljanec, Jože of ARS. 2010. List of rectors and magisters (Pregled lektorjev in magistrov) 1678–1749. Typescript.

APUG – archive, Pontificia Università Gregoriana, Rome. Numbers show folio and page.

Anonymous. Around 1700. De Physica = De Physico Audit Consider Physica compositus naturale. 400 pages. APUG 1532.

Esteran, Manuel, SJ. Around 1720. Liber 4ur Physica. (Philosophia pars 2do Physica Proemium ... Pertenca ad (= pertence a) P. Manuel Esteran). APUG 2144a, 2144b. SLU films 7168.3, 7169.1.

Guarini, Ignazio (noted by his student Giovanni Filippo Buoninsegni). 1706. Philosophiae Pars Secunda seu Disputationes de Physico Audit quas Ab Adm. Rev. P'dre Ignatio Guarino e Soc. Yes. Philosophicus Trienius and Collegio Siense prelegate Audit ac scripsit Joannes Phillipus Buoninsegni Anno D'ni 1706. APUG 2 Adiuncta.

Kobav, Andrej. 1 January 1640. His explanation of the motion of comet in his Viennese letter mailed to Kircher (APUG, 567, folios 20^r-21^v).

Panici, Joannes (Giovanni Jacobo). 1700. Panici P. In Libros, Aristotelis De Physico Auditio Disputationes. APUG 1093, SLU film 3564.2

AVA Min CU - Das Österreichische Staatsarchiv (ÖStA), Allgemeines Verwaltungsarchiv, Ministerium für Kultus und Unterricht, (Ministry of Education and Worship-Religion of Habsburgian Monarchy), Vienna.

Baden-Württemberg Landesarchiv Baden-Württemberg, Staatsarchiv Ludwigsburg. Note about Hlubek's Piston pump

Stuttgart, Württemberg Regional Library, Code Math Foll 14a, The State Library of Württemberg (*Württembergische Landesbibliothek*, WLB) traces its history back to the ducal public library of Württemberg founded in 1765. Briefwechsel Johannes Kepler - Cod.math.qt.14a – 14b, Volume 14a, Kepler an Mästlin (Kepler's letter to Maestlin), 8.12.1598 (163) – 89r to 181 - 89r (Code Math Folios 14a 163-181).

Brussels Bibliothèque Royale, cabinet des Manuscrits (Royal Library of Belgium as the national library of Belgium, Room of Manuscripts of the Royal Library of Belgium in Brussels)

Dubrovnik = Ragusa

HR DADU – State (Državni) archive in Dubrovnik A.1. Uprava i javne službe do 1848:

Fond HR DADU 81: reference code **Okružno poglavarstvo Dubrovnik** (1816–1868) Urudžbeni zapisnik, 1822, books V, no. 5539/784 Urudžbeni zapisnik, 1823, Tern. VII.

Fond HR DADU 156 Zborni prvostupanjski građanski i kazneni sud u Dubrovniku (the First Instance Civil and Criminal Court in Dubrovnik, 1819–1852), Ostavine (Heritages), Sez. E, Fasc. VI, no. 45. Krascovich Dr. Gregorio Ventilazione d’Eredità Hanner Gregorio sua tutela.

Franjevački samostan Duha Svetoga u Fojnici (Fojnica OFM Monastery of Silver Province of Bosnia (Provincia OFM Exaltationis S. Crucis - Bosna Argentina, Bosna Srebrena)):

Anonymous. 1739. Latin anti-Cartesian and anti-Lutheran work on the possible movement in the vacuum, noted under the goose pen of the domestic father with a dated proprietary entry on 9 December 1739, manuscript no. 44.

FSKA – Books and manuscripts in the library of Franciscan Monastery of Kamnik.

FSLJ = The reference codes of Books & manuscripts kept at Library Franciscan monastery, Ljubljana, also noted by the letter F:

Anonymous. 1744/45. *Philosophia Aristotelica Joannis Duns Scoti Doctoris subtilis, solidissimis ac invertibilibus principiis ac firmissimis fundamentalis insistens. Dialectica Institutiones et Logica; Philosophia naturalis*. Manuscript (FSLJ-10 g 41, FSLJ-10 g 42).

Anonymous. 175?. *Incipit Philosophia naturalis, seu Physica / Liber Quartus Physicorum / Generatione et corruptione / Mundo et coelo / Liber Sextus Physicorum de Continuo*. Manuscript (FSLJ-16 g 115).

Anonymous. 175? (Before the discovery of Uranus in 1781). *Incipit Philosophia naturalis, seu Physica / ad Mentem Mariani Doctoris Joannis Duns Scoti*. Manuscriptum (FSLJ-16 h 115, unpaginated, its last folio lost, about 650 pages of 20 x 16 cm; kept in the cover of the other today not shelved or catalogued book FSLJ-16 h 20 and with ex libris: “Cella XLIX / Procuratus Pro Conventu Labacensis / Anno 1777”. Note with a pencil: “Duplicate”.

Anonymous. 1768. *Institutiones philosophiae ... In Dei nomine tractatus ad universam physicam sive scientiam naturalem* (Bind to the dialectics dated in the same year). Manuscript of 192 pages with unpaginated index of topics on the end (FSLJ-4 b 5 with unapproved reference code noted during WW2 as FSLJ-29 f 29). Resembling but not identical to the manuscript with similar ornaments of 1771 (FSLJ-5 h 34).

Anonymous. 1770-1771. *Tractatus Metaphysicus seu Universalis Philosophiae; Particularis Physica*. Manuscript (FSLJ-5 h 34 (FSLJ-29 f 34)).

Anonymous. 1772?. (*Incipit*) *Physica generalis*. Manuscript (FSLJ-13 i 68).

Anonymous. 1772? (1772–1774). (*Incipit*) *Physica generalis*, (FSLJ-13 i 68).

Dinarić, Vigiliij (Vigilius, Vigilio Dinarich). 1735. *Inscrit Philosophia naturalis seu physica ad placibus doctoris subtilis Scoti*. Manuscript dated on 27 March 1735 and 20 June 1735. Bind to: *Inscrit Philosophia naturalis, de generatione et corruptione* dated on 16 July 1735. (FSLJ-13 c 81).

Franciscans of Ljubljana diary. noted in the years 1658/1660 – 1828. *Tyrocinium seraphicum... in duas divisus partes./ Quarum prior noviter idutorum / Posterb veró solemniter Professorum / Seriem continet*, FSLJ with no reference code available. Ljubljana.

Hieber, Castul; (with exam of his student Varingo Garsberger). 11 August 1793/1796. *Theses Philosophicae ex logicae, Metaphysicae et Mathesi pura quas in conventu studis Cambensi (Cham in Bavaria) P.P Franciscanorum publica disputatione*

exponit P. Castulus Huber Philosophiae lector ord. Defendas... P. Varingo Garsberger, Monastery Cham (*Cambiensi*) in East Bavaria 50 km northeast of Regensburg (FSLJ-1 d 50).

Hieber, Castul. 1797. *Philosophia Corporum seu Physica: Pars I generalis ex variis / Novissimis Autoribus con gesta ai Systemate ordinata pro annis Praelectionibus P. Castuli Hieber* (227 pages)/ *Notiones et Definitiones ex Geometria* (five unfinished separately paginated pages). Monastery Cham (*Cambiensi*) in East Bavaria 50 km northeast of Regensburg (FSLJ-15 b 65).

Markilič, Hieronym. 1755?. *Manuscript P. Hieronymi Markillitsch Franciscani philosophia lectoris / Incipit Philosophia naturalis seu Physica Secundum principia et Doctrinam Mariani Doctoris Subtilis Joannis Duns Scoti* (FSLJ-3 c 71). Unpaged 862 pages of A4/2 format. On 6 November 1938 I. Medved noted its undated continuation as *Dialectica manuscriptum*, FSLJ-3 c 70-72.

Markilič, Hieronym. 1755?. *Manuscript P. Hieronymi Markillitsch Franciscani philosophia lectoris / Incipit Tractatus in libros Aristotelis de generatione et corruptione* (FSLJ-3 c 72). Unpaged 395 pages of A4/2 format.

Markilič, Hieronym. 1769-1774. *Scripta Theologia Dogmatica* (FSLJ-12 c 4-7). On p. 4: 306/307 a subtitle: *Dissertatio secunda veritatis catholica sanctissimo eucharistia sacramento in qua contra neotericos, et prasertim contra nostrum P. Fortunatum a Brixia (et alios recentiores) asseritur, et defenditur... aliquid teala physicum a parte rei existens extra sensus...*, Ljubljana 1769, FSLJ-12 c 7.

Medved, I. 1938. *Manuscripta conventus pp. Franciscanorum Ljubljanensis*. Manuscript dated on 6 November 1938, leaves bind together containing description of manuscripts held in FSLJ, 12,8 x 7,6 cm (FSLJ with no reference code available). In 2015 updated by Miran Špelič and Jože Škofljanec.

Pfeiffer, Gotfrid (Godefridi). 1735/1736. *Cursus philosophicus praelectus iuxta mentem Doctoris Subtilis studiosae Juventuti (iuventuti) á Patre Godefridi Pfeiffer Philosophia Lectore actuali*. Only the second part (tomus 2dus) of the manuscript was

preserved entitled *Complectens Scientiam Naturalem seu Physicam universam*, Sveta Gora above Gorizia (Holly Mountain) (FSLJ-29 f 24).

Ruessenstein, Alexis baron. 1694. *Drittes Buch / von denen zusammen getragenen Schriften des Herren Alexij Baron von Ruessenstein* (The reference code of Ljubljana Franciscans' Library FSLJ-29 F 54), (1)694. Copy on 234 pages. *Alexis baron Ruessenstein, Drittes Buech / von denen zusammen getragenen Schriften des Herren Alexis Baron von Ruessenstein* (von Salzburg) (FSLJ-29 F 56), (1)694. Original on 513 pages.

Škerpin, Žiga. 1714, 1718. *Commentaria in Aristotelis Stagyrtae octo libros Physicorum*. Manuscript. The first book (448 pages, 1714, FSLJ-6 d 4), and the second book (431 pages, Trsat, 1718, FSLJ-6 d 57).

Špelič, Miran OFMobs. 2010. *Nekrologij province sv. Križa (Obituaries of Province of St. Cross)*. Typescript at FSLJ.

Zinsmeister, Theophilus, *Tractatus ex Physica*. Manuscript, 1799, FSLJ-1 d 48.

Zinsmeister, Theophilus, Ad usum P. Theophili Zinsmeister/ (*Prolegomena*) *Theologia dogmatica*, 204 pages, on the beginning of unbind added 4 pages of Narratio in somewhat bigger format. Manuscript, 1800?, FSLJ-4 c 70.

FSMA = archive of Franciscan monastery in Makarska (Croatia, Arhiv franjevačkog samostana u Makarskoj):

Dorotić, Andrija. About 1795. *Physicae generalis libri quattour* (part of: *Cosmologia; Physicae generalis continuatio; Physica particularis, de mundo; Institutiones physicae; Exaratio universae philosophiae. T. H; Physica particularis; Physica generalis et particularis*). Manuscript produced in Rome where he taught philosophy and Natural History.

FSNM = The reference codes of Books & manuscripts in Franciscan library of Novo mesto.

Toš, Tarzicij. 1942-1944. Standard Subject

Catalogue: 12 expert groups with alphabetical arrangement of authors inside their groups, preserved in manuscript written on unbound sheets. *FSNM*.

GDP – Sources of family Peterlin, by Tanja Peterlin-Neumaier in München (Gradivo Družine Peterlin).

Peterlin, Anton, 1940. *Fizika*. Ljubljana: Cyclostyled edition of Bulgarian students of mining engineering. Notes of author dated in 1950.

Peterlin, Anton. 1970. *Anton Peterlin* (autobiography, typescript, GDP).

Peterlin, Anton. 1981. *My Scientific Life* (autobiography, typescript, GDP).

Gospić, Državni arhiv u Gospiću (National Archive Gospić) established in 1999

Matična knjiga vjenčanik i umrlih Parohije Gospić (Priests' Register of marriages and deaths (funerals) in parish Gospić) 1885-1940.

Graz:

StLA – Styrian Land archive in Graz (Steiermärkische Landesarchiv).

Library of Technical University Graz (TU, Technische Universität).

Archive of Technical University Graz (TU, Archiv of Technische Universität Graz):

Schaschl, Josef; Pöschl, Jakob. 1878/79. *Technische Physik nach den Vorträgen des Herrn J. Pöschl k. k. ö. o. Professor and der k. k. technischen Hochschule in Graz 1878/79*. Universitätsbibliothek der TU Graz.

Graz, Roman Catholic Priests' Registers
Graz Heilige Blut Sterbebuch = Matricula of Graz Roman Catholic Parish inside the Diocese (Diözese) Graz-Seckau (book of funerals).

Graz-Graben Sterbebuch = Diözese Graz-Seckau
Graz-Graben Sterbebuch no. III 1867-1909 (3rd book of funerals).

HHStA, FAA – Catalogue of Ljubljana based library of Prince Auersperg (Ljubljanska knežja knjižnica). 1668/1672 (*Haus-, Hof- und Staats-archiv, Dep. Fürstlich Auerspergsches Archiv*, VII Laibach, A 14/4 conv. 1 Laibach-Fürstenhof 1729-1895, Vienna, Minoritenplatz 1):

T = Books of former Auersperg princely («knežja») library, kept in Ljubljana until the late 19th century.

S – Schönleben's Catalogue of Ljubljana library of Prince Auersperg's brother Wolf in HHStA, FAA.

IJS

IJS, Archive of IJS in Podgorica - archive of Institute Jožef Stefan in Podgorica with more than thousand boxes, in March-June 2003 edited by experts from ARS. Box 326, map 578.

Archive Južnič, Fara pri Kostelu in Slovenia:
Notes of dr. Veronika Kralj Igljč on 16 May 2005 and 8 October 2005.

Note by mag. Djordj Krstić on 16 May 2005
Note by dr. Danica Burg-Hanžel on 15 September 2005.

Legacy inventory of Ivan Kuščer, Ljubljana, mailed by Janez Stepišnik on 31 January 2006.

Legacy inventory of Milan Osredkar, Ljubljana, mailed by Janez Stepišnik on 31 January 2006.
Zupančič, Črt (Črtomir). 14 March 2007. Zgodnji spomini na Antona Peterlina (Memoires).
Unpublished typescript. 18 pages.

Klagenfurt (Celovec) and other parts of Carinthia
Roman Catholic Priests' Registers of Carinthia diocese of Gurk (Krka):

Klagenfurt-St. Egid (Egidus), Sterbebuchs (Book of Funerals).

Klagenfurt-St. Lorenz, Geburtsbuchs (Taufbuchs, Baptismal Books).

Klagenfurt-St. Lorenz, Trauungsbuchs (Book of Marriages).

Klagenfurt-St. Lorenz, Sterbebuchs (Book of Funerals).

Eberndorf (Dobrla vas) of the Völkermarkt District in Carinthia east of Klagenfurt, Geburtsbuchs (Taufbuchs, Baptismal Books).

Breže in Carinthia (Friesach), Trauungsbuch (Book of Marriages).

Ferlach (Borovlje), Roman Catholic Priests' Registers

Ferlach (Borovlje) Sterbebuch = Matricula of Ferlach (Borovlje) Roman Catholic Parish inside the Diocese (Diözese) Gurk (Krka) (4th book of funerals).

KLEKL = The reference codes of Books at Klekl's library (Kleklova knjižnica) in Črenšovci.

Koper (Capodistria):

City Archive Inventory Koper. 1850-1871. Inventario del gabinetto di Fisica disposto nell'ordine cronologico degli acquisti. City Archive Koper, X R. Ginnasio superiore di Capodistria (Higher Grammar School (gymnasium) in Koper), reference code 10, 3.

Library of the Italian Language Grammar School (gymnasium) in Koper, reference codes of books.

Kremsmünster Sternwarte, Stift Kremsmünster, A-4550 Kremsmünster, Austria, Direktions-Archiv der Sternwarte Kremsmünster, Manuscripts.

Koller, Marian, Vorlesungen „aus der gesamten Physik in der 8^{ten} Classe des Lyzeum" an der philosophischen Lehranstalt zu Kremsmünster (1826-1839, Lectures about physics read at philosophical studies in Kremsmünster) von P. Marian Koller. Koller-Manuskripte, 15a (I. Abteilung: Chemie, Mechanik, Akustik on 694 pages together with later added title page) and 15b (II. Abteilung: Optik, Magnetismus, Elektrizität, on 672 pages together with later added title page).

Marian Koller's manuscript notes taken from J. Stefan lectures at Viennese University (Vorlesungen

von Prof. Dr. Josef Stefan):

a) „Theorie der Elasticität fester Körper (Theory of elasticity of solids)", taught in winter semester 1861/62, 36 folios (= 144 pages), Manuscript no. 18.

b) "Über die Theorie der Wärme (On theory of Heat)", lectured during winter semester 1862/63 with L. Boltzmann also among the students, 35 folios (= 140 pages), Manuscript no. 31.

c) "Über Elektrodynamik und Theorie der Induction (About electrodynamics and the theory of induction)", taught in summer semester 1862/63, 26 folios (= 104 pages), Manuscript no. 32.

d) „Über die Theorie des Lichtes (About the Theory of Light)", taught in winter semester 1863/64, 30 folios (= 120 pages), Manuscript no. 26.

e) „Über Interferenz, Beugung, Polarisation (On Interference, Diffraction, Polarization)", taught in summer semester 1863/64, 10 folios (= 40 pages, Manuscript no. 27) (Manuscript, Directions-Archive of the Observatory (Sternwarte) Kremsmünster).

KKKRS = The reference codes of books at library of Krško Capuchins.

KSMA - Books of library of former monastery of Capuchins in Maribor dissolved in 1784.

KSSKL = The reference codes of books at library of Škofja Loka Capuchins (Kapucinski Samostan Škofja Loka):

Redeskini, Ambrozij. 1778. *P. Ambrosii Redescini de Haidovio O.C. Institutiones universae Philosophia Recentioris, usibus discipulorum accomodatae*. Zagrebiae. Before WW2 and in 1960 in KSSKL.

KSVK = Capuchin Monastery Vipavski križ (Kapucinski Samostan Vipavski križ):

Anonymous. 1749. *Index Cathalogi bibliothecae ad facilius repriendos libros in eo contentos, compositi Anno 1749*. Vipavski križ. KSVK.

Maribor:

City study library (Mestna študijska knjižnica) Maribor.

University of Maribor library (UKM).

Mayr's sales catalogue = Mayr's bookkeeping offer to Ljubljana residents in 1678 published by Janez Krstnik (Joannis Baptistae). 1678. *Catalogus Librorum qui Nundinis Labacensibus Autumnalibus in Officina Libraria Joannis Baptistae Mayr. Venales prostant. Labaci (Ljubljana): Mayr.*

MINSPT = books of Library at Minorite monastery of St. Peter and Paul in Ptuj (Friars Minor Conventual, OFMConv, Minoritski samostan sv. Petra in Pavla, Ptuj).

NMLJ = The reference codes of books and manuscripts in Library of National Museum (Narodni Muzej), Ljubljana.

ER = Book numbers of Mathematical and Physics part of Erberg's library of Dol by Ljubljana, today mostly in NMLJ after Karl Dežman's acquisitions. Also catalogued in SI_AS 730 GrA. Sorted by topics including physics, mathematics.

NŠALj = Archbishopric (Archdiocese) archive in Ljubljana:

T (TE) = Terpin's catalogue of Gornji Grad (Upper Castle) library = Terpin, Filip. 1655. *Terpin Philipus. Studi. Theolog. Baccalaureus Vic. Gen. Lab. Constitutiones, et Index librorum et authorum bibliothecae Oberburgensis excellentissimi et reverendissimi principis episcopi Labacensis conscriptus per reverendum dominum Philippum Terpin vicarium generalem anno 1655* (signed on 14 October 1655 in Gornji Grad) (NŠALj, Bishopric archive (Ljubljana). Cathedral Chapter archive (Kapiteljski Arhiv), Fascicle 96/14; photocopy in NUK-manuscript department 39/83).

NUK = The reference codes of books and manuscripts at National & university library (Signature Narodne in univerzitetne knjižnice) in Ljubljana, stored in Collection of manuscripts and rare prints (Rokopisna zbirka in zbirka redkih tiskov):

Baeda Venerabilis (Bede, Beda). 12th Century. *Commentarius in Matheum (Explanatio super Matheum), Expositio in Libros regum and Varia.* NUK Ms. 18

Codelli, Baron Anton von Fahrenfeld, Legacy inventory, NUK, manuscript section, Reference code: Ms. 1397 (cited as: Codelli, NUK): III (155); 141, Nr. 3458, Nr. 3408 III (Codelli's TV patents).

Codelli, baroness Rozalija (Rosalia). *Lebenserinnerungen.* 710 pages of autobiographical manuscripts of Anton Codelli's mother Rosalia Taufferer. NUK, manuscript section, Reference code: Ms. 1397.

Čop-Kalister's catalogue of Ljubljana Lyceum books in NUK denoted by letter Č. In 1826-1831 catalogued by Kalister and in 1832-1835 by Čop, with later supplements of librarians.

J-... = Library numbers in the book *Catalog of former Jesuits' books of Ljubljana* listed by Janez Wanggo and Joseph Dollhopff as: *Verzeichnis der vom Feuer geretteten Bücher des Gewesten Collegii S.J.* original (first transcript) with a sub-title: "*Specification deren Bey der gewesten Feuersbrunst and den Leybach. Collegio Geretteten Bücher*" (NUK, manuscript department, manuscript 30/83). Second transcript, dated 1 March 1775: "*Specification deren Büchern, welche zum Theil in dem Gewesten Collegio zu Laybach in einem Kasten Verwahrt Gewesen, und zum Theil durch Studentes nach und nach zusammengetragen*". For the books noted after number 605, the new title was issued: "*Specification deren Büchern, welche nach der letzten Publications Eingegangen Seynd*" (NUK, manuscript department, manuscript 31/83). Preserved books were numbered, numbers are the same as those written on the outer cover of books in today's NUK.

Jesuits. *Historia Annua Collegii Labacensis anni 1722-1773.* NUK. 5/53; *Annua Collegii Labacensis 1722-1773.* NUK. Ms 1544 (former owner was FSLJ after 1773).

Peer, Karel (Karl), *Bücherverzeichniß aus dem Peerischen Verlaß* (NUK-manuscript with inventory number 32/83).

ST = anonymous. 1784. *Algemeinen B. k.k. Bibl. Sittich = Catalogue Alphabetisches Verzeichniß der kaiser. königl. Bibliothek zu Sittich (Stična*

Cistercian Monastic Library). NUK Ms. 22/83 (copy); Ms. 21/83.

W - Wilde, Franz Ksaver (Franc). 1803. *Catalogi Librorum Bibliothecae Publicae Lycei Labacensis in Ducatu Carnioliae. Alphabethisches literarisches Verzeichnis der in der Laybacher Lycealbibliothek vorhandenen Werke* (Library Numbers and List of the Ljubljana Lyceum Library) (NUK. Manuscript division (Handwriting department)). Also, somewhat later Supplementum.

Zelli, Rafael. 1811. *Registre de correspondance*. VII NUK, manuscript division.

Josef Schober's catalogue of Zois' books in Ljubljana noted from 1783 up to 1797, and Jakob Zupan's (1785-1852) catalogues produced in 1810-1816 (NUK, Ms. 368; Svoljšak, Vidmar, 2019, 21, 97, 149).

Z = Zois, Žiga. 181?. *Bibliothecae Sigismundi Liberi Baronis de Zois – Catalogus*. NUK, Ms. 667. Selling catalogue authored by Matija Kalister and the bookseller Viljem Henrik Korn finished on 4 August 1821 with 4109 volumes (NUK-Ms 667; Kidrič, 1939, 9; Svoljšak, Vidmar, 2019, 11, 99).

Zois, Žiga. *Verzeichniss der schätzbaren literarischen werke, die der Hoch und Wohlgeborne freyherr Baron Sigismund Zois der diesartigen Lyceal-Bibliothek in den Jahren 1808 und 1815 als ein Geschenk verehret hat* (NUK-manuscript with inventory number 43/83 (the reference code Ms. 1950), earlier Zois' donations to Lyceum Library of Ljubljana inventoried by numbers 40/83, 41/83, 42/83; Svoljšak, Vidmar, 2019, 11).

Oklahoma University, Bizzell Library History of Science Collections:

Paolitto, Valentino (former owner). After 1657. *17th-century Sphaera: In triplicem spheram, terrestrem, aeream, et coelestem breves adnotates*. No note of date or author. Manuscript once owned by Valentino Paolitto now kept in University of Oklahoma, Bizzell Library History of Science Collections.

Zacco (Zacchi), Augusto. 1680/1681. *Com(m)entaria In Primam Partem Philosophiae Naturalis Aristotelis De phisico auditu Iuxta Mentem Angelici Divi Thomae Aquinatis Domini Augusti Zacchi Patritii Veneti* (August 1680-November 1681). Manuscript kept in Oklahoma University, Bizzell Library History of Science Collections.

PAM

Provincial archive Maribor (PAM) fond Mestna občina (City) Maribor, 1528–1941

The reference code SI_PAM/0005

K 22 (books) – Index 1879 General Registration (splošna registratura)

K 101 – Delovodnik (Workbook) 1879 (splošna registratura, Geschaefts Protokoll 1879, no. 2160, 8 March 1879 & no. 2675, 24 March 1879)

K 531 – Registers = Obrtni registri, vodeni na podlagi obrtne zakonodaje 1859–1907: register za proste in rokodelske obrti 1866–1883; indeksi k obrtnim registrom: indeks I, proste in rokodelske obrti

Technical unit (Tehniška enota) 642: Zbirke mikrofilmov gospodinjne kartoteke občine Maribor.

The reference code SI_PAM/0973 Staff register (Matične knjige delavcev) 1860–1990, factories of South railway, later factory of cars and thermal engineering (Južne

Employment record book (Matic books of workers) 1860–1990, factories of South railway, later factory of cars and heat technique (Južne železnice, later Tovarna vozil in toplotne tehnike) Boris Kidrič, Maribor.

PMSLJ

PMSLJ = The reference codes of books and manuscripts in Library of Natural history Museum (Prirodoslovni Muzej), Ljubljana in the same building with National Museum (Narodni Muzej), Ljubljana.

POMPI = The reference codes of books of Pomorski muzej-Museo del mare 'S.Mašera' in Piran-Pirano.

Prague

Archiv Akademie věd České republiky, Praha, A. Fondy institucí, Fondy starších vědeckých společností, ústavů a spolků, Královská česká společnost nauk (KČSN, Societas Scientiarum Bohemica; Königlische böhmische Gesellschaft der Wissenschaften) 1766–1953.

Archiv Národního Muzea, Praha, Šternberk-Manderscheid Fond (ŠM) k64.

SASA (SAZU)

SAZU Knjižnica = Library of SASA – Books, Manuscripts & typescripts at library of Slovenska Akademija znanosti in umetnosti, Novi trg, Ljubljana:

M = Magić, Vladimir; Valvasor, Janez Vajkard; Kukulja, Božena (ed.); Gostiša, Lojze; Šikić, Žana; Gaberščik, Boris (photographer). 1995. *Bibliotheca Valvasoriana* katalog knjižnice Janeza Vajkarda Valvasorja (*catalogue of library of Janez Vajkard Valvasor*). Ljubljana: Valvasor's odbor pri SAZU; Zagreb: Nacionalna i sveučilišna library.

Varaždin

State archive, Varaždin, Gradsko poglavarstvo Varaždin, HR-DAVŽ-2: Poglavarstvo slobodnog i kraljevskog grada Varaždina, 1209–1850

Vienna

ÖAWB = Library of Austrian (Habsburgian) Academy of Science in Vienna (Österreichische Akademie der Wissenschaften, Bibliothek, Wien) Dr. Ignaz Seipel-Platz 2 1010 Wien.

Stefan, Josef (Jožef). 1879. *Über die Beziehung zwischen der Wärmestrahlung und der Temperatur*. His preliminary manuscript announcement notice of *Wien. Ber.* II. 79: 391-428 publication at the meeting of Viennese academy on March 10, 1879 (Auszeiger-Notiz. Vorlegt in Der Sitzung am 10. März 1879 durch Verfasser). 4 pages of manuscript noted by the reference code 282 ex 1879 in the library of Austrian (Habsburgian) Academy of Science in Vienna (Österreichisches Akademie der

Wissenschaften, Wien (in our text quoted as "summary").

Šubic, Simon. Manometer - Hygrometer, a manuscript reviewed by Karl Jelinek on 19 April 1876, kept at ÖAWB 314 ex 1876.

Austrian State Archives (National Archives of Austria, Österreichisches Staatsarchiv, AT-OeStA, Archiv (ÖStA)). Nottendorfer Gasse 2, 1030 Wien: AT-OeStA/AVA Unterricht UM *Unterrichtsministerium*, 1848-1940, AT-OeStA/AVA Unterricht UM (Ministerium für Kultus und Unterricht, OSTA (ÖStA), 1). Reference code: 4 Phil. Stefan. 1 6215/1858. Stefan, J. (1858–1878): Universitäts Akten, fol. 1–4, Ministerium für Kultus und Unterricht; Personalakts Jožef (Josef) Stefan (Stefan Archive): Four folios of documents on Stefan's career at the University of the Habsburg Ministry of Education and Worship (Kultus und Unterricht). Documents dated: January 26, 1863, February 9, 1863 (pp. I-IV), September 20, 1866 (pp. 1-12), October 27, 1878 (pp. 1-5) and January 26, 1879 (pp. 1-13).

Archiv der Universität Wien (Archive of the University of Vienna), Postgasse 9, 1010 Wien:

Personalakts Jožef (Josef) Stefan (Stefan Archive): Reference code: 106_I_3988 showing members of the Physics Institute on Erdberg, Hauptstraße no. 104 street in Vienna (Mitglieder des Physikalischen Instituts in der Erdbergstraße) including Ludwig Boltzmann and Professor Josef Stefan. In 1851 the Institute was built there, while in 1875 the institute was moved to Türkenstraße no. 3, Photography Format Positive B x H: 18 x 12 cm. Undated photo, taken in 1873-1876.

Personalakts Jožef (Josef) Stefan: Philosophischer Dekanats Akt der Universität Wien - Josef Stefan's personnel file. 1892/93, Reference code: PH PA 3508

A document (a receipt) with several signatures by some professors (among others by Josef Stefan), that is part of the collection of autographs. Reference code: 151.248, Autographen auf einer Empfangsbestätigung der Universität Wien (Autographs on a confirmation of receipt from the

University of Vienna), 1874-1875 (Dokument (Einzelstück, single piece of document)) Information of Thomas Maisel, Archiv der Universität Wien, 1010 Wien, Postgasse 9, on 5 June 5 2020 8:21 AM.

Vienna, Archive of Benedictines = Archiv des Benediktinerstiftes Unserer Lieben Frau zu den Schotten (Archives of the Schottenstift in Vienna), A-1010 Wien, Freyung 6.

Vienna and other places in Lower Austria
Roman Catholic Priests' Registers:

Wien, rk. Erzdiözese (östl. Niederösterreich und Wien), 01 (1st Bezirk Inner City), Am Hof, Trauungsbuchs (Book of Marriages).

Wien, rk. Erzdiözese (östl. Niederösterreich und Wien): 1st Bezirk Inner City, St. Augustin, Sterbebuchs (Book of Funerals).

Rennweg - Maria Geburt (in the 3rd municipal district Landstraße of Vienna), Taufbuchs (Geburtsbuchs, Baptismal Books).

Rennweg - Maria Geburt (in the 3rd municipal district Landstraße of Vienna), Trauungsbuchs (Book of Marriages).

St. Othmar unter den Weißgerbern (in the 3rd municipal district Landstraße of Vienna), Taufbuchs (Baptismal Books).

St. Othmar unter den Weißgerbern (in the 3rd municipal district Landstraße of Vienna), Trauungsbuchs (Book of Marriages).

Landstrasse - St. Rochus (in the 3rd municipal district Landstraße of Vienna), Taufbuchs (Baptismal Books).

Landstrasse - St. Rochus (in the 3rd municipal district Landstraße of Vienna), Trauungsbuchs (Book of Marriages).

Landstraße-Erdberg (in the 3rd municipal district Landstraße of Vienna), Trauungsbuchs (Book of Marriages).

Erdberg St. Peter und Paul (in the 3rd municipal district Landstraße of Vienna), Taufbuchs (Baptismal Books).

Erdberg St. Peter und Paul (in the 3rd municipal district Landstraße of Vienna), Trauungsbuchs (Book of Marriages).

Wieden (4th municipal District (Bezirk) of Vienna, Wien, rk. Erzdiözese (östl. Niederösterreich und Wien)) Taufbuchs (Baptismal Books).

St. Florian (Matzleinsdorf) (5th district Margareten of Vienna), Trauungsbuch (Book of Marriages).

St. Josef zu Margareten (5th district Margareten of Vienna), Trauungsbuch (Book of Marriages).

Lichtental (part of the 9th district Alsergrund of Vienna), Taufbuchs (Baptismal Books).

Rossau (Roßau) part of the 9th district of Vienna, Taufbuchs (Baptismal Books).

Votivkirche in 9th district (Bezirk) of Vienna, Trauungsbuchs (Book of Marriages).

Votivkirche in 9th district (Bezirk) of Vienna, Taufbuchs (Baptismal Books).

Waehring in 18th Bezirk Waehring, Sterbebuchs (Book of Funerals).

Gersthof in the eighteenth district (Bezirk) Währing (Waehring) of Vienna, Sterbebuchs (Book of Funerals).

Pötzleinsdorf in the eighteenth district (Bezirk, Gemeindebezirk) Währing (Waehring) of Viennas Sterbebuchs (Book of Funerals).

Wien, rk. Erzdiözese (östl. Niederösterreich und Wien), Fischamend (city in the district of Bruck an der Leitha in the Austrian state of Lower Austria), Taufbuchs (Baptismal Books).

ZAL

ZAL (SI_LJU) - *Zgodovinski archiv (Historical archive)* Ljubljana, unit in Ljubljana, Mestni trg 27, Ljubljana.

SI_LJU 184 (Fond Classical Gymnasium Ljubljana) akc. fond (Accessory fond) 1, box 52, map 179

Kersnik, Janez Krstnik. 1811. *Inventaire des objects existantes dans le Cabinet de Chimie et de Physique des écoles centrales à Laibach (A list of devices in the chemical and cabinet of physics of the Central Schools in Ljubljana for the year 1811)*. SI_LJU 184, Accessory fond (Akc. Fond) 1, archival technical unit - box (arhivska enota) 53.

Kersnik Janez Krsnik. 1847. *Inventorium, List of devices in the cabinet of physics of Lyceum in Ljubljana for 1847*, SI_LJU 184, Accessory fond (Akc. Fond) 1, archival unit (arhivska enota) 76.

Mitteis, Heinrich. 1866. *Inventorium (Inventory) der Instrumente, Apparate, Sonstigen Unterrichtsbehelfe und Einrichtungsstücke des Physikalischen Kabinetes an k. k. Gymnasium in Laibach*. SI_LJU 184, Accessory fond (Akc. Fond) 1, archival unit (arhivska enota) 49.

SI_LJU 184, Accessory fond (Akc. Fond) 1, archival unit (= box, arhivska enota) 75 and 78.

SI_LJU ZAL, LJU 469, Mestni ljudski odbor Ljubljana, Premoženjske zadeve, nemške zaplembe (City People's Committee of Ljubljana, Property Affairs, German confiscations), Box no. 3, zaplemba (expropriation) no. 160/45 (Codelli), August 29, 1945; Legacy of Anton baron Codelli.

SI_LJU Free Trades (Prosti obrti), Cod. XX–, No. 45

SI_LJU 500, Fatherland department (Domovinski oddelek), microfilms 403 and 567

37.2 WEB

Counts of Celje (Cilli)
<http://genealogy.euweb.cz/baden/baden1.html>
Retrieved 20 October 2015

Counts of Celje (Cilli) inside the Hungarian Order of the Dragon
http://www.bibliotecapleyades.net/sociopolitica/esp_sociopol_dragoncourt07.htm Retrieved 20 October 2015

Vacuum sealing of coffee
<http://chrisgrande.com/2010/07/24/the-history-of-hills-brothers-coffee-and-the-vacuum-seal-mystery/> retrieved on March 3, 2020

Vacuum sealing of coffee
<http://www.zepter.si/MainMenu/Products/HomeArt/Vacsy/Product-Range.aspx> retrieved on March 3, 2020

History of vacuum coffee siphon
<http://chrisgrande.com/2010/07/24/the-history-of-hills-brothers-coffee-and-the-vacuum-seal-mystery/> Retrieved 20 October 2015

Distillation: Chinese liquor Du Kang
<http://www.drinkingcup.net/chinas-oldest-liquor-du-kang/> Retrieved 20 October 2019

Distillation: Chinese liquor
http://www.chinadaily.com.cn/life/2010-10/27/content_11692216.htm Retrieved 20 October 2019

Doane, Joseph William. History of Research at the Kent University Liquid Crystal Institute. 1–3
<http://www.lci.kent.edu/researchhistory.html>
Retrieved 20 October 2010

Dolenc, Sašo. 27 December 2004. Book Review of Južnič's *Zgodovina raziskovanja vakuuma in vakuumskih tehnik 1*. Ljubljana: Društvo za vakuumsko tehniko Slovenije. Kvardakabra
<http://www.kvardakabra.net/article.php/Juznic-zgodovina-vakuuma> Retrieved 20 October 2010

DVTS history
http://www.dvts.si/arhiv/1984/1984_2/1984_2_1_10Odpi.pdf retrieved on March 3, 2020

B.F. Erberg on Johann Christoph Müller's geography

<http://mapy.mzk.cz/mzk03/001/037/038/2619267403/> Retrieved 20 October 2019

B.F. Erberg on Johann Christoph Müller's geography
<http://gis.fns.uniba.sk/kartografickelisty/archiv/KL17/3.pdf> Retrieved 20 October 2019

B. F. Erberg geography dedicated to Theodor baron Pelichy and Turksweert
<http://oghb.be/recueils/la-famille-de-pelichy>
Retrieved 20 October 2019

B.F. Erberg's geography <http://reader.digitale-sammlungen.de/de/fs1/object/display/bsb1102631800295.html> Retrieved 20 October 2019

Graz TU <http://history.tugraz.at/lehrende/dozenten/>
Retrieved 20 October 2015

T. Gruber's correspondent Ferenc Count Széchenyi
<http://www.mek.oszk.hu/01600/01644/01644.pdf>
Retrieved 20 October 2019

Haldane family, List of surnames
<Http://www.spiers.net/alltree/> Retrieved 20 October 2019

Andreas Hohenwart
http://www.waymarking.com/waymarks/WMT8A8_Andrej_Hochenwartskii_Castle_Chapel_of_St_George_Ljubljanski_Grad_Ljubljana Retrieved 20 October 2019

Lampe, Anton. 1914. (Obituary of) Ferdinand Lippich, *Lotos* (Prague: *Deutschen Naturwissenschaftlich-Medizinischen Vereines für Böhmen "Lotos"*), volume 62 pages 13-18
http://www.landesmuseum.at/pdf_frei_remote/Lotos_62_0013-0018.pdf Retrieved 20 October 2019

Maribor Grammar School
<http://www.pgmb.si/zgodovina-prve-gimnazije-maribor/> consulted on February 28, 2013.

packing in vacuum
<http://www.zeptr.si/MainMenu/Products/HomeArt/Vacsy/Product-Range.aspx> Retrieved 20 October 2019

Josef Petzval
http://monoskop.org/images/2/27/Choma_Milan_Jozef_Maximilian_Petzval_a_Otto_Baltazar_Petzval_Vyznamni_matematici_zo_Spiskej_Belej.pdf
Retrieved 20 October 2015

Chandra Kant Raju on Indic origins of westernized sciences <http://ckraju.net/> Retrieved 20 October 2015

British patents <http://www.ebooksread.com/authors-eng/great-britain-commissioners-of-patents/the-commissioners-of-patents-journal-aer/page-12-the-commissioners-of-patents-journal-aer.shtml>
consulted on March 13, 2013

Peter Resch in Anti Duell Liga für Österreich
<http://forum.ahnenforschung.net/archive/index.php/t-19011.html> consulted on February 20, 2012.

Nikola Tesla's and M. Pupin's teachers in Rakovac and Pančevo (*Kais. königl. Militär-Schematismus* 1869-1870 volume 1 page 874)
<http://babel.hathitrust.org/cgi/pt?id=mdp.39015062383578;seq=878;view=1up;num=874> and
<https://babel.hathitrust.org/cgi/pt?id=mdp.39015062383578&view=1up&seq=890> retrieved 19 January 2013.

Nikola Tesla's and M. Pupin's teachers in Rakovac and Pančevo (*Kais. königl. Militär-Schematismus*. 1871 volume 1 page 881).
<http://babel.hathitrust.org/cgi/pt?id=mdp.39015062383560;seq=887;view=1up;num=881> retrieved 19 January 2013

Tesla in Karlovac city
http://www.archive.org/stream/gradkarlovacopi00stroog/gradkarlovacopi00stroog_djvu.txt retrieved 19 January 2013

Nikola Tesla's and M. Pupin's teachers in Rakovac and Pančevo (*Kais. königl. Militär-Schematismus*. 1872 page 689)
<http://www.archive.org/stream/kaiskoniglmlit01krieogoo#page/n681/mode/2up> consulted on 18 January 2013.

Nikola Tesla's and M. Pupin's teachers in Rakovac, Pančevo, Rijeka and Pula (Kais. königl. Militär-Schematismus. 1872 pages 689, 713)
<http://babel.hathitrust.org/cgi/pt?id=mdp.39015062383552;seq=718;view=1up;num=714> consulted on 19 January 2013.

Nikola Tesla's biography
http://www.novosti.rs/dodatni_sadržaj/clanci.119.html:280070-Nikola-nece-mantiju Retrieved 20 October 2019

Tesla's Gospić [http://gimnazija-gospic.skole.hr/upload/gimnazija-gospic/newsattach/32/Skolski_plan - 2011 12.pdf](http://gimnazija-gospic.skole.hr/upload/gimnazija-gospic/newsattach/32/Skolski_plan_-_2011_12.pdf)
Retrieved 20 October 2019

Nikola Tesla's memoires
http://www.novosti.rs/dodatni_sadržaj/clanci.119.html:280072-Tumac-i-cuvar-vere consulted on 26 February 2013

J. Trump merits as narrated by Amy Davidson on April 8, 2016,
<http://www.newyorker.com/news/amy-davidson/donald-trumps-nuclear-uncle> Retrieved 20 October 2019.

Tschermak Edler von Seysenegg
<http://www.deutsche-biographie.de/sfz9124.html>
and

http://www.tigis.cz/images/stories/psychiatrie/2011/04/02_cek Psych 4-11.pdf Retrieved 20 October 2019

37.3 Printed Sources

Abgottspon, German. 1939. *P. Valerianus Magni Kapuziner (1586-1661). Sein Leben im alklgemeinen, seine apostolische Tätigkeit in Böhmen im besonderen. Ein Beitrag zur Geschichte der katolischen Restauration im 17. Jahrhundert.* Freiburg im Breisgau: Otto Walter.

Abraham, Henri Azariah; Langevin, Paul (ed.). 1905. *Les quantités élémentaires d'électricité. Ions, électrons, corpuscules.* Paris: Gauthier-Villars, 1-2.

Adam, Lucijan. 1995. Donesek k zgodovini Ortenburžanov na Dolenjskem (Notes to the history of Ortenburg in Lower Carniola). *Kronika.* 43/3: 7-13.

Adamcik-Preusser zu Niederberg, Helga Monika Maria (Adamčik). 2004. *Die wissenschaftliche Bedeutung der physikalischen Arbeiten von Jožef Stefan (Several aspects of Jožef Stefan's scientific work in physics).* PhD Dissertation. University of Vienna.

Adler, Friedrich; Mach, Ernst. 2001. Selected Mach-Adler Correspondence, *Ernst Mach's Vienna 1895-1930: Or Phenomenalism as Philosophy of Science* (Ed. J.T. Blackmore). Boston Studies in History and Philosophy of Science. 45-60.

Adlešič, Miroslav. 1952. *Od mehanike do elektronike : knjiga o fizikalnem mišljenju in tehničnem ustvarjanju (From mechanics to electronics).* Ljubljana: Mladinska Knjiga (Juvenile books).

Adlešič, Miroslav. 1957. *Svet svetlobe in Barv (World of Light and Colours).* Ljubljana: Mladinska Knjiga (Juvenile books).

Aepinus, Franz Maria Ulrich Theodosius. 1758. *Riech' o skhodstvie elektricheskii sily s magnetnoiü: v publichnom sobranii Imperatorskoï Akademii Nauk ... v den' 7 sentiabria 1758 govorenaia professorom fiziki F.U.F. Epinusom (Риэч о сходящ электрический сила с магнетной: в публичном собрании Императорской Академии Наук ... в день 7 сентимбриня 1758 г. говорнаина*

профессором физики Ф.У.Ф. Эпинусом, Akademische Rede von der Aehnlichkeit der elektrischen und magnetischen Kraft). Petersburg: Typis Academiae scientiarum Petropolitanae. Translations: 1760. *Akademische Rede von der Aehnlichkeit der elektrischen und magnetischen Kraft, welche in der feyerlichen Versammlung der Kaiserlichen Akademie der Wissenschaften im Jahr 1758 ... öffentl. vorgelesen hat.* Leipzig: Gleditsch; 1768. *Sermo academicus De similitudine vis electricae atque magneticae in solenni conventu Academiae Imperialis Scientiarum A.O.R. MDCCLVIII die VII. septembris : cum dies nomini augustae russorum imperatricis Elisabetae primae sacer celebraretur, publice praelectus a F.V.T. Aepino,* Petersburg: Typis Academiae scientiarum Petropolitanae; Biwald's promotion published before with another Aepinus's work: 1771. *F.V.T. Aepinus öffentlichen Lehrers der Physik bey der Kaiserlichen Akademie der Wissenschaften in Petersburg, der Königlichen Preussischen Akademie der Wissenschaften zu Berlin, und der Churfürstlich-maynzischen Gesellschaft Nützlicher Wissenschaften zu Erfurt Mitgliebes Zwo Schriften, I. Von der Aehnlichkeit der elektrischen und magnetischen Kraft. II. Von den Eigenschaften des Tourmalins.* Graz: Widmanstätterische Erben (FSLJ- 2 h 99).

Aepinus, Franz Maria Ulrich Theodosius. 1762. *Recueil de differents memoires sur la tourmaline, publié par M. Franç. Ulr. Théod. Aepinus.* Petersburg: Typis Academiae scientiarum Petropolitanae. Translations: 1771. *De similitudine vis eletricae et magneticae & de novis quibusdam experimentis circa Electricitatem Tourmalini.* Petersburg: Typis Academiae scientiarum Petropolitanae; Biwald's promotion published before after another Aepinus's work: 1771. ... II. *Von den Eigenschaften des Tourmalins.* Graz: Widmanstätterische Erben (FSLJ- 2 h 99).

Aepinus, Franz Maria Ulrich Theodosius. 1768. *Tentamen theoriæ electricitatis et magnetismi. Accedunt dissertationes duæ, quarum prior phænomenon quoddam electricum, altera magneticum explicat.* Petersburg: Typis Academiae scientiarum Petropolitanae.

Aepinus, Franz Maria Ulrich Theodosius. 1979. *Aepinus's Essay on the Theory of Electricity and Magnetism*. Princeton: University Press.

Agnes, Luciano. 2006. *Ruggero Giuseppe Bošković un professore Gesuita all'Università di Pavia (1764-1768)*. Milano: Cisalpino.

Agricola, Georg. 1546. *De ortu et causis subterraneorum lib. V. De natura eorum quae effluunt ex terra. lib. IIII De natura fossilium lib. I De veteribus et novis metallis lib. II Bermannus, sive de re metallica dialogus. Interpretatio germanica vocum rei metallicae, addito indice foecundissimo*. Folio. Basilea: Froben. (NUK-8947; ST-21/83 103^v).

Ahačič, Kozma. 2007. *Zgodovina misli o jeziku in književnosti na Slovenskem: protestantizem*. Ljubljana: ZRC SAZU.

Airy, Georg Biddell. 1871–1872. *Proceedings of the Royal Society (London)*. 20: 35–39.

Akin, Károly (C. K.). 1866. A Calsescentiáról (About Calcescence) *Természettudományi Tudom. Társ. Közlöny (Journal of Natural Sciences)*.

Akin, Károly (C. K.), 1867. Ueber Calcescenz und Fluorescenz, *Ann.Phys.* 131 (207/8): 554-561.

Akin, Károly (C. K.). 1867. Erwiderung auf eine Notiz des Hrn.Emsmann, *Ann.Phys.* 131 (207/8): 561-564.

Al-Biṭrūjī, Nur al-Din ibn Ishaq (Alpetragius); Bernard Raphael Goldstein; Mosheh Ibn Tibon. 1971. *Al-Biṭrūjī: On the principles of astronomy: I, Analysis and translation an edition of the Arabic and Hebrew versions with translations, analysis, and an Arabic-Hebrew-English glossary*. New Haven/London: Yale University Press.

Alfvén, Hannes. 1950. *Cosmic Electrodynamics*. Oxford: Clarendon Press. A modernized & extended version of first four chapters of 1st edition: Alfvén, Hannes; Fälthammar, Carl-Gunne. 1963. *Cosmic Electrodynamics. 2nd edition [Part 1]. Fundamental principles*. London: Oxford University Press/Clarendon Press.

Alfvén, Hannes. September 1986. The Plasma Universe. *Phys.Today*. 39/9: 22-29.

Ambrožič, Matjaž. 2007. Pozabljena preteklost župnije Kočevska Reka v očeh njenih duhovnih pastirjev. In (ed. Ambrožič, Matjaž; Ferenc, Mitja; Zupan, Gojko). *V objemu stoletij*. Ljubljana: Družina. 9-177.

Ambshell, Anton. 1778. *Josephs v. Herbert der Weltweisheit Doktors, und k. k. öffentlichen, und ordentlichen Lehrers der Physick an der hohen Schule zu Wien Abhandlung von der Federkraft des Wassers, und einiger anderen flüssigen Körper: Aus dem Lateinischen ins Deutsche übersetzt von Anton Ambshell, der Weltweisheit Doktor, und k. k. öffentlichen, und ordentlichen Lehrer der Physick an der Akademie zu Laybach*. Laibach: Eger. Bind to: 1778. *Assertiones ex universa philosophia quas in aula academica archiducalis gymnasii Labacensis ex praelectionibus ... Antonii Ambshell ... Antonii Tschokl ... Martini Jel ... mense Julio ... anno MDCCCLXXVIII. propugnabit ... Josephus Cypriani / Casparus Sluga*. Labaci (Zois' book now NUK-GS 0 5129; NUK-GS I 109761; NMLJ; UKM; FSLJ-17 d 80).

Ambshell, Anton. 1780. *Dissertatio de motu in genere in subsidium suorum discipulorum conscripta*. Laibach: Eger (FSLJ-23 g 29 with propriety entry: "ad usum Frater Athanasii Schwarz Clerici 1784").

Ambshell, Anton. 1792. *Anfangsgründe der allgemeinen auf Erscheinungen und Versuche gebauten Naturlehre*. 6 volumes. Wien: Schmidt.

Ambshell, Anton. 1807. *A. A. Ambshell in Universitate Vindobonensi AA.LL. ac Philosophiae Doctoris, Facultatis ejusdem Senioris, Physicae et Mechanicae Professoris Caes.Regii Publici et Ordinarii Elementa Physicae e Phaenomenis et Experimentis Deducta, aut Auditorum Conscripta, ac in Dissertationes Sex Divisa*. Vienna: Sumptibus Aloysii Doll Bibliopolae.

Ames, Joseph Sweetman (ed.). 1898. *The Free Expansion of Gases. Memoirs by Gay-Lussac, Joule, and Joule and Thomson*. New York/London: Harper & Brothers.

Amiot, Jean-Joseph Maria. 1774. Observations météorologiques faites à Pékin, par le P. Amiot, Décembre 1762. Mis en ordre par M. (Charles) Messier. *Mémoires de mathématiques et de physique, présentés à l'Académie Royale des Sciences*. 6: 519-601.

Amiot Jean-Joseph Maria (with scientific editors Cibot, Pierre-Martial; Batteux, Charles; Bréquigny, Louis George Oudard Feudrix de; Silvestre de Sacy, Antoine-Isaac; Bourgeois, François; Poirot, Aloys de). 1784. *Mémoires, concernant l'histoire, les sciences, les arts, les moeurs, les usages, &c. des Chinois / par les missionnaires de Pe-kin (2 October 1784)*. Paris: Nyon aîné, Treutel & Würtz.

Amiot, Jean-Joseph Maria; Henri Bernard. 1943. *Le Frère Attiret au service de K'ien-Long (1739-1768): Sa première biographie écrite. Par Amiot; rééditée avec notes et commentaires par Henri Bernard*. Shanghai: T'ou-Se-We, Dép. Rech. histor., Univ. Aurore,

Amon, Chrysostomus. 1860. Fragen über die physikalische Atomenlehre und ihre Folgen, *Jahresbericht des kaiserl. königl. Ober-Gymnasiums zu Wiener-Neustadt 1859/60*, 3-6 (philosophy of atoms without kinetic theory focused on relationship between Christianity and atomism or wave theory on six pages). Separate print: 1860. Wien: Carl Gerold's Sohn.

Amon, Chrysostomus. 1861. Das Pythagoräische oder reine Quinten-Tonsystem und seine Übereinstimmung mit der musikalischen Praxis, *Jahresbericht der Obergymnasiums Wiener-Neustadt (Programm Wiener-Neustadt Gymnasium) 1860/61*. Separate print: 1861. Wien: Gerold. Pp. 3-18. Review of Šubic, Simon: 1862. *Z. öst. Gym.* 13: 562-563.

Amon, Chrysostomus. 1862. Die Tonleitern der Griechen. *Jahresbericht der Obergymnasiums Wiener-Neustadt 1861/62*. 20 pages. Separate print: 1863. Wien: Carl Gerold's Sohn. Pp. 3-14 with two tables.

Amon, Chrysostomus. 1863. Die Tonschrift der Griechen. *Jahresbericht der Obergymnasiums Wiener-Neustadt 1862/63*.

Amon, Chrysostomus. 1869. Das pythagoräische Tonsystem und seine Begründung in den Naturgesetzen, *Jahresbericht der Obergymnasiums Wiener-Neustadt 1868/69*.

Amort, Eusebius. 1730. *Philosophia Pollingana ad normam Burgundicae, in qua I. Summulae, Logica, et Metaphysica eomodq, quo in Academico dictari solent, continentur. II. Principia peripatetica, praecipue juata scholam recentiorum, ad captum explicantur; demonstrator et cim mechanicas Newtonicorum (Neotericorum) principiis concilatur. III. Experimenta praecipua, quae post editionem Philosophiae Burgundicae ab academia regiascientiaeum Parisiensi aliisq auctoribus prodierunt, suppleuntur. IV. Varia nova opuscula philosophica in serentur, inter quae: 1. Vindice prorsus nova ac solidae Phliae peripateticae. 2. Notitia critica de Logica Veterum et Neotericorum, praesertim Platonis, Lulli Arlandi, Wilffi. 3. Principia artis criticae explicate ac demonstrate in quibus continentur regulae criticae ex SS. Patribus et dissertation de authoribus ex stylo dignosondis. 4. Systemata omnium Philosophorum, praesentim Gassendi, Cartesii, Newtoni et chymicorum. 5. Refusata Systematis Copernicana nova. 6. Notitia accurate, de coelis, ex novissimis observationibus. 7. Novum Systema declinaris magnificae. Autore R. D. Eusebius Amort. Canonico. Augsburg: Veith. (noted by: Lind, 1992, 368). (NUK-5032). 3rd part: 1734. Venetiis: Recurti (FSLJ; J-609; NUK-4867; ST-22/83 109^v).*

Anderson, David Leonard. 1964. *Discovery of the electron: the development of the atomic concept of electricity*. Princeton, N.J.: Van Nostrand Compagny, cop. Translation of Kucheryayev, Orlov, and Vasiljev: 1968. *Otkrytie èlektrona: (razvitie atomnych koncepcij električestva) (Открытие электрона. Развитие атомных концепций электричества*. Пер. с англ. Виктор Александрович Кучеряев (Kucheryayev), Юрий Викторович Орлов (Orlov), Георгий Андреевич Васильев (Vasiljev)). Moscow: Atomizdat (Атомиздат).

Anderson, Philip. 6 March 1987. The Resonating valence bond state and La(2)CuO(4) and superconductivity. *Science*. 235/4793: 1196-1198.

Andrade, Edward Neville da Costa. 1984. The History of the Vacuum Pump. *History of Vacuum* (ed. Madey; Brown). 77-83.

Andrejka, Rudolf. 1938. Zgodovina kramarskih hišic v Prešernovi ulici, *Kronika slovenskih mest (Ljubljana)*, 5/1: 17-22.

Andrews, Thomas. 1852. On a method of obtaining a perfect vacuum in the receiver of an air-pump. *The London, Edinburgh, and Dublin Philosophical Magazine and Journal of Science*, 3/16 (185202): 104-108 and *Journal of the Franklin Institute*, v/3 (185209): 199-201. Reprint: 1889. *The Scientific Papers of the Late Thomas Andrews, Vice President and Professor of Chemistry Queen's College Belfast*. London/New York: Macmillan and Co.

Andrews, Thomas. 1869. On the continuity of the gaseous and liquid states of matter: the Bakerian Lecture; received June 14, - read June 17, 1869. *Philosophical Transactions of the Royal Society of London* (London: Taylor and Francis), no 159 (31 December 1869): 575-590. Reprint: 1889. *The Scientific Papers of the Late Thomas Andrews, Vice President and Professor of Chemistry Queen's College Belfast*. London/New York: Macmillan and Co. pp. 296-301.

Andritsch, Johann. 1977-1987. *Die Matrikel der Universität Graz*, Bd. 1: 1586-1630; Bd. 2: 1630-1662. Bd. 3: 1663-1710. Bd. 4: 1711-1765. Graz: Akadem. Druck- u. Verlagsanstalt.

Angius, Vittorio. 1855. *L'automa aerio o sviluppo della soluzione del problema sulla direzione degli aerostati*. Torino: Cassone.

Ångström, Anders Jonas. 1855. Optische untersuchungen (Optical investigations). *Ann. Phys.* 94: 141-165.

Antolić, Moriz. 1864. Der Diamagnetismus und seine wichtigsten Beziehung zum Magnetismus. *Jahresberichte der k. k. Ober-Realschule zu Rakovac in der k. k. Kroatisch-Slavonischen Militär-Grenze*. 1-10.

Aochi, Rinsō (青地林宗). 1825/1827. *Kikai Kanran* (気海観瀾, Atmospheric Observations). Tōti (Tokyo): Hōkoen Meizankaku.

Apian, Peter. 1524. *Cosmographicum liber Petri Apiani Mathematica studiose collectue*. Basileae: Henri Petrina (NUK-G 4330; Bind to Münster 1533). 1533 (ST-21/83 97^v in 21/83 100^f); 1551 (ST-21/83 99^f); Translation: 1575. *La cosmographia de Pedro Apiano, corregida y añadida por Gemma Frisio, medico y mathematico. La manera de destrucruir y situar los Lugares, conel vao del anillo astronomico, del mismo auctor Gemma Frisio. El sitio y description de las Indias y mu(n)do nuevo, sacada dela historia de Francisco Lopez de Gomara, y dela cosmographia de Ieronymo Giraua Tarragonéz*. En Anvers (Antwerp): Iuan Bellerio al Aguila de Oro (T).

Apih, Elio. 1977. Carli, Gian Rinaldo (Keyword). *Dizionario Biografico degli Italiani*. Volume 20: 161-167,

Arago, François. 1825. VI Détonations extraordinaires dans l'île de Méléda. *Oeuvres Completes* volume XI, pp. 657-660; *Annales de Chimie et de Physique*, series 2, 30: 432-435; notes on: Détonations extraordinaire dans l'île Méléda. *Bulletin (Universal) des Sciences, Mathematiques, Astronomiques, Physiques et Chimiques: Première section du Bulletin universel des sciences et de l'industrie* (Paris: Fain, edited by Jacques Frederic Saigey & André Etienne d'Audebard baron Férussac), 8 (1827): 193.

Arcimovich, Lev Andreevich. 1964. *Controlled thermonuclear reactions*. Edinburgh & London: Oliver & Boyd

Arco, Count Georg Wilhelm Alexander Hans; Albert Einstein; Walburga Geiger; Hellmut von Gerlach; Maximilian Harden; Max Hodann; Luise Kautsky; Elisabeth Rotten; Erich Schlesinger; Helene Stöcker (eds.). September 1919. *I Lille. Beiträge zur Naturgeschichte des Krieges*. Berlin: Hans Robert Engelmann. 59 pages. Revised expanded second edition: Arco, Count Georg Wilhelm Alexander Hans; Walburga Geiger; Max Hodann; Elisabeth Rotten; Erich Schlesinger (eds.). 1920. *I Lille*.

Beiträge zur Naturgeschichte des Krieges. Berlin: Hans Robert Engelmann. 71 pages in German and French languages on war crimes committed by the German Army in French town Lille during WW1.

Arco, Count Georg Wilhelm Alexander Hans. 1924. Radio, Internationalismus, Pazifismus. *Die Friedens-Warte (Journal of International Peace and Organization)* Berlin or Switzerland: Berliner Wissenschafts-Verlag, 24/4-7 (April/July 1924: 156-158).

Arco, Count Georg Wilhelm Alexander Hans. 1928. *Die verschiedenen Hochfrequenzmaschinen für ungedämpfte Sender von Großstationen.* Berlin: Gesellschaft für drahtlose Telegraphie m.b.H. 8 pages.

Ardenne, Manfred von. 1931. Über Neue Fernsehender und Fernsehempfänger mit Kathodenstrahlröhren (About TV). *Fernsehen.* 1: 65-80.

Ardenne, Manfred von. 1932. Über Helligkeitssteuerung bei Kathodenstrahlröhren. *Fernsehen.* 3: 18-29.

Aristotles (Aristotle). 1987. *Physics.* Zagreb: University Press Liber.

Aristotles; Argyropoulos, Joannes; Sunczel, Fridericus. 11 May 1499. *Collecta et exercitata Friderici Sunczel Mosellani liberaliu(m) studioru(m) magistri in VIII libros physicorum Aristotelis in almo studio Ingolstadiensi.* Hagenaw: Heinrich Gran, Johannes Rynman (NUK-R 488). Reprint: Argyropoulos. 1508. *Libri octo physico & Aristotelis per Joannem Argyropoli et graeco in latinu traducti.* Venetiis: Jacobus Pentius (Leonard Alantse) (ST=NUK-16575, bind to: Argyropoulos; Sunczel. 1506. *Collecta et exercitata Friderici Sunczel Mosellani liberaliu studio & magistri in octo libros physicorum Aristotelis: in almo studio Ingolstadiensi.* Venetiis: Jacobus Pentius (NUK-18112, NUK-R 20834, T); 23 October 1500. *Questiones de utiles librorum de anima cum adjecione textus novae translationis Joannis Argyropoli Bisanti Cirai questiones.* Venetiis: Jacobus Pentius (Leonard Alantse) (NUK-18123).

Aristotle; Averroes; Zimara, Marcanton; Mantini (Mantino, Mantinus), Jakob. 1562. *Aristotelis (Stagiritae) Omnia quae extant opera, nunc primum selectis translationibus ... Add. etiam nonnullis libris nunquam antea latinitate donatis: Averrois Cordubensis in ea Opera omnes qui ad nos pervenere commentarii ... Quorum aliqui non amplius à Latinis visi, nuper à Jacob Mantino sunt conversi, alii ab eodem clarius ac fidelius, quàm unquam antea ab aliis, translati: caeteri ex manuscriptis optimisque codicibus philosophorum hac nostra aetate celeberrimorum, innumeris penè locis diligentissime castigati : singuli compluribus margineis scholiis exornati. Levi Gersonides annotationes in Aver. Expositionem super logices libros ... eodem Jacob Mantino interprete. Græcorum, Arabum, & Latinorum monumenta quaedam, ad hoc opus spectantia. M. Antonii Zimarae in Aristotelis & Averrois dicta contradictionum solutiones. Jo. Baptistae Bagolini Veronensis labore, ac diligentia. Venetiis: Junctas (FSLJ-20 h 10 acquired in 1644, former owner: 1592 Davidi Reitgartleri Segmen).*

Aristotle; Du Val, Guglielmo (Guillaume Duval, editor). 1629. *Aristotelis Opera Omnia Quae Extant, Græcè & Latinè. Veterum Ac Recentiorum Interpretum, Vt Adriani Turnebi, Isaaci Casauboni, Julij Pacij studio emendatissima: Cvm Kyriaci Strozæ ... Libris Dvobvs Græcolatinis de Republicâ in Supplementum Politicorum Aristotelis; Sed nouissimæ huic Editioni ... accessit brevis ac perpetuus in omnes Aristotelis libros Commentarius, siue Synopsis Analytica Doctrinæ Peripateticæ, non antehac visa... Authore Gvillielmo Dv Val Pontesiano... Qui & præter operosam illam Synopsin, adiecit Anthologiam Anatomicam... & præterea libros quatuordecim diuinius Philosophiæ seu Metaphysicorum, notis & argumentis auxit & illustravit...; Indices tres operum molem claudunt ac veluti obsignant... [Tomus Primus]. Lutetiae Parisorum (= Paris): Anton Stephan Typis Regiis (In Greek and Latin Language, FSLJ-3 k 1-2). Reprint: 1654. *Aristotelis Opera omnia, Graece et Latine: doctissimorum virorum interpretatione & notis emendatissima, & nunc tandem in quatuor tomos distributa / Guillelmus Du-Vallius ... tertio recognouit, synopsin analyticam adiecit, nouis disquisitionibus, notis, [et] appendicibus illustravit ; cum tribus indicibus; quae**

huic editioni accesserunt pagina proxima indicabit. Paris: Ioannem Billaine, Simeonem Piget, Frederic Leonard (NUK-GS III 444/I-II).

Armengaud, Jules Alexis Marie junior; Charles Armengaud; Ed. Becquerel; Henri Becquerel; et all (eds.). 1881. *L'électricité et ses applications: Exposé Sommaire et Notices sur les Differentes Classes de l'exposition: Rédigés par Mm. Armengaud, Ed. Becquerel, H. Becquerel, Paul Bert, Blavier, Ant. Breguet Clérac, M. Deprez, Hip. Fontaine, Mascart, Raynaud (exposé sommaire et notices sur les différentes classes de l'exposition (Exposition Internationale d'Électricité, Paris))*. Paris: Lahure.

Arnu, Nicholas (Arnù, Niccolò). 1670. *Clypeus philosophiæ thomisticæ. Veridica S. Thomæ Aquinatis Doctoris Angelici, & Alberti Magni doctrina exornatus: validissimisque rationibus eorundem munitus. Contra novos eius impugnatores... F. Nicolao Arnu... Biterris (Béziers, France): Henricus Martel.*

Arnu, Nicholas (Arnù, Niccolò). 1685. *Dilucidum Philosophiæ synagma E D. Toma Aquinatis Doctoris Angelici, B. Alberti Magni, & optimorum quorumque Philosophorum effatis ac dogmatibus concinnatum, variaque eruditione locupletatum. 3,1 Octo libros physicorum complectens... 5,1 De Meteoris, Mineralibus, atque Lapidibus; Theologiam Naturalem, seu Metaphysicam complectens. Tomus Septimus*. Seven parts, 606 pages, 1-2, Patavii: Brigoncius (= Peter Anton Brigoneil) (FSLJ-10 g 55, 606 pages). Continuation: 1686. *Dilucidum philosophiæ syntagma e D. Thomæ Aquinatis doctoris angelici, B. Alberti Magni, & optimorum quorumque philosophorum effatis ac dogmatibus concinnatum, variaque eruditione locupletatum 3,1 Octo libros physicorum complectens... Patavii: Peter Anton Brigoneil (FSLJ-18 d 63-69 (FSLJ-11 g 31-37)).*

Artsimovich, Lev Andreievich (Arcimovič, Лев Андреевич Арцимович, Artsimovich). 1961. *Управляемые термоядерные реакции (Upravliaemye termoiadernye reaktsii)*. Moskva: Fizmatgiz (Gos. izdatel'jstvo fiziko-matematicheskoi litury). Translation of Paul Joseph Kelly and Adam Peiperl edited by Alan Charles Kolb and Rendel Sebastian Pease: 1964. *Controlled*

Thermonuclear Reactions. New York: Gordon and Breach Science Publishers.

Asclepi, Giuseppe Maria. 1765. *De objectivi micrometri usu in planetarum diametris metiendis. Exercitatio Optico-Astronomica habita in Collegio Romano a Patribus Societatis Jesu Anno MDCCLXV. III. Non. Sept.* (3rd day before Nonae Septembres (Nones September) on 5th September, therefore on 3 September 1865). Romae: Giovanni Generosi Salomoni. Simultaneous print with no other later date noted promoted by Biwald with identical title page except for printer's seal and name on the bottom and repaired number iiii into III. and Non. Sept. no more printed in italics by Graz: Widmanstadi. The same Graz edition promoted by Pogrietsnig and bind to his *Assertiones ex universa philosophia, quas in archi-ducali, et academico Societatis Jesu gymnasio Labaci anno M. DCC. LXVIII. mense Augusto die_ publice propugnandas susceperunt eruditus ac perdoctus dominus Franciscus Karpe, Carniolus Labacensis, ac perdoctus dominus Franciscus Suetiz, Carniolus Lythopolitanus e sem. S.J. ex praelectionibus R.P. Joannis Baptistae Pogrietsnig e Societate Jesu philosophiæ professoris publici, et ordinario* (NUK-GS 4255; NUK-GS 8209; FSLJ-18 i 11; NMLJ-3804-3805 with ex libris propria of Ignac von Rosenberger another sealed ex libris from Dežman's heritage: Carl Deschmanns legat an das Rudolfinum 1889).

Asimov, Isaac. 1975. *Biographical Encyclopaedia of Science and Technology*. London/Sydney: Pan Books. Reprint: 1978. *Biographical Encyclopedia of Science and Technology*. London: Pan Books Ltd.

Auger, Pierre. 1925. Sur l'effet photoélectrique compose (On composite photoelectric effect). *J. Phys. Radium*. 6: 205-208; *C. R. Hebd. Séances Acad. Sci.* 180: 65.

Autrum, Hansjochem Otto (ed.). 1987. *Von der Naturforschung zur Naturwissenschaft: Vorträge, gehalten auf Versammlungen der Gesellschaft Deutscher Naturforscher und Ärzte (1822-1958)*. Berlin/Heidelberg: Springer.

Avicenna with Averroes' comments. 1489-1490. *In fine expletus est liber primus canonis quem princeps*

aboali Abinsceni de medicina edidit. Translatis canticorum Avicenne cum commentaris Averrois: facta ab Arabico in latinum a magistro Armegandi Blasii de Montepessulano (Canon medicinae). Venetia: Dionysium (Bertachorum) Bononcinsen (NUK-11294).

Avogadro, Amedeo. 1816, 1817. Memoria sul calore specifico de' gaz composti paragonato a quello dei loro gaz componenti, del cavaliere Avogadro, professore di fisica a Vercelli. Parts 1-2. *Biblioteca italiana o sia giornale di letteratura scienze ed arti* (Part II: Science ed arti meccaniche) Milano: Antonio Fortunato Stella. 4 (October-November-December 1816): 478-491; 5 (1817): 73-87. Reprint: 1911. *Opere Scelte di Amedeo Avogadro pubblicate dall R. Accademia delle scienze di Torino*. Torino: Unione tipografico-editrice Torinese.

Ayber, Refah. 1965. *Thomson-Joule-Effekt von Methan-Wasserstoff- und Äthylen-Wasserstoff-Gemischen*. PhD thesis, Düsseldorf: Vereins Deutscher Ingenieure.

Azuma, Toru. 1993. The Science Experiments by Shozan Sakuma and the Science Books in Dutch "Galvanische-Schok-Machine" and Elektrische Stromen. *Kagakusi Kenkyu (Journal of History of Science, Japan)*. 28/171: 143-151.

Baader, Joseph. 1797. *Vollständige Theorie der Saug- und Henepumpen, und Grundsätze zu ihrer virtheilhaftesten Anordnung, vorzüglich in Rücksicht auf Bergbau und Salinenwesen...* Bayreuth: J.A. Lübecks Erben.

Bacon de Verulam, Francis. 1622, 1623. *Francisci Baronis de Verulamio, Vice-Comitis Sancti Albani, Historia vitæ et mortis. Siue, titulus secundus in Historiâ naturali & experimentalis ad condendam philosophiam; quæ est Instaurationis magnæ pars tertia* (known as *Historia naturalis et experimentalis de ventis*, or *Historia ventorum*). London: John Haviland, impensis Matthæi Lownes. Reprint: 1636. *Francisci Baronis de Verulamio, Vice-Comitis Sancti Albani, Historia Vitæ & Mortis: sive titulus secundus in Historia Naturali & Experimentalis ad condendam Philosophiam: quæ est Instaurationis Magnæ pars tertia* (known as *Historia ventorum*). Lugduni (Leyden): J. Maire (FSLJ-25 f 55). Second

Extended reprint in its first edition: 1638. *Francisci Baconi ... Operum moralium et civilium tomus qui continet Historiam regni Henrici Septimi, regis Angliæ. Sermones fideles, sive interiora rerum. Tractatum de sapientia veterum. Dialogum de bello sacro et Novam Atlantidem: ab ipse honoratissimo auctore, præterquam in paucis, Latinitate donatus / cura & fide Guilielmi Rawley ...; in hoc volumine, iterum excusi, includuuntur Tractatus de augmentiis scientiarum. Historia Ventorum. Historia vitæ [et] mortis; adjecti sunt, in calce operis, libri duo Instaurationis magnæ*. which included: *Novum organum scientiarum; Parasceve ad historiam naturalem ex experimentalem*. London: excusum typis Edwardi Griffini; prostant ad insigna regia in coemeterio D. Pauli, apud Richardum Whitakerum, some volumes also on sale by John Haviland, Bernard Norton, John Bill (noted as Ioannem Billium at last volume of 1620) and John Norton (propriety entries of count Wolfgang Engelbert Auersperg dated in 1655 and his brother Janez Vajkard prince Auersperg with ex libris of Auersperg Ljubljana library on inner cover front page. On inner last cover page printed ex libris of Nicholas Wall (the judge Sir Nicholas Peter Rathbone Wall), now NUK- GS II 31039).

Bacon de Verulam, Francis. 1609. *De sapientia veterum liber*. Londini: Robert Barker. Translation of Johann Wilhelm count Stubenberg: 1654. *Francisci Baconis Grafens von Verulamio, wieland Englischen Reichcantzlers... Fürtrefflicher Staats-Vernunfft und Sitten-Lehr-Schriften. I. Von der Alten Weissheit. II. Etliche Einrahtungen, aus den Sprüchen Solomonis. III. Die Farben (oder Kennzeichen) des Guten und Bösen. Übersetzt durch Ein Mitglied der Hochlöblichen Fruchtbringenden Gesellschaft den Unglücklichen (Unglückseligen)*. Nürnberg: Michael Endter (dedicated to Janez Vajkard Auersperg, not in Slovenian public libraries today).

Bacon de Verulam, Francis. 1662. *Historia naturalis*. Amsterdam: Elzevir (FSLJ-22 e 62).

Bacon de Verulam, Francis. 1662. *Francisci Baconi Baronis de Verulamio, Vice Comitis P. Albani, Sumi Anglice Cancellarii. Opera omnia, qua extant: philosophica moralia, politica, historica. Tractaus nempe de dignitate et augmentis scientiarum*.

*Historia ventorum. Historia vitae et mortis. Scripta de naturali et universale Philosophia. Nova Atlantis. Historia regni Henrici VII. Regis Anglice: opus vere politicum. Sermones fideles, sive Interiora rerum. Tractatus de sapientia veterum. Dialogus de bello sacro. Opus illustre in felicem memoriam Elisabethae Reginae. Imago civilis Julu Caesaris. Imago civilis Augusti Caesaris. In quibus complures Alii Tractatus, quos brevitatis causa raetermittere visum est, comprehensi sunt. Haltenus nunquam conjunctim edita, jam vero sumo studio collecta, uno volumine unprehensa, et ab inumeris mendis repurgata. Cum indice rerum et verborum universali absolutissimo. His praefixa est auctoris vita (cum ejus effigie). Francoforti Ad Moenum (Frankfurt): Joanis Bapt. Schönwetter (Z, now NUK-5022). Reprint: 1694. *Francisci Baconi Baronis de Verulamio, Vice. Comis S. Alani, sumi Anglice Cancellarii. Opera omnia, cum novo eos insigni augmento tractatum in latinum sermonem translatorum opera Simonis Joannis Arnoldi, Ecclesia Sonnenburgensis Inspectoris.* Lipsiae: Impensis Joannis Justi Erithropili; escu. debat Christianus Goesius (NUK-GS 5031).*

Bacon de Verulam, Francis. 1762. *Francisci Baconis de Verulamio summi Angliae Cancellarii, Novum Organum Scientiarum (Edited by Andreas Tosi). Editio I.-ma Veneta.* Venetiis: Gaspar Girardi (Z, now NUK-4628). Reprint: 1775. Venetiis: Franciscum Ex Nicolas Pezzano (NUK-GS 4522).

Badash, Lawrence. 1987. Ernest Rutherford and Theoretical Physics. *Kelvin's Baltimore Lectures and Modern Theoretical Physics* (edited by Robert Kargon, Peter Achinson). The MIT Press, pp. 349-373.

Karl Siegfried Bader; Froben Christoph von Zimmern. 1942. *Die Zimmerische Chronik (1288-1566) als Quelle rechtlicher Volkskunde.* Freiburg im Breisgau: Herder.

Bader, Luigi. 1977. *Les Bourbons de France en exil à Gorizia.* Paris: Perrin. Translation: 1994. *I Borboni di Francia in esilio a Gorizia.* Gorizia: Cassa di Risparmio.

Baeyer, Otto von. 1908. Über langsame Kathodenstrahlen. *Verhandl. Deut. Phys. Ges.* 5: 96-

114; Reprint; 1909. *Phys. Z.* 10: 168/169-186, Translation: Reflection and Secondary Radiation of Slow Kathode Rays. *Journal of the Röntgen Society,* 5/21 (7): 112.

Bahčič, Robert OFM. 2007. *Čudež, ki traja 800 let. Zgodovina Frančiškove karizme v svetu in pri nas.* Ljubljana: Brat Frančišek.

Bahor, Stanislav. 2000. Stična. *Handbuch deutscher historischer Buchbestände in Europa – eine Übersicht über Sammlungen in ausgewählten Bibliotheken* 9. Hildesheim & Zürich & New York: Olms-Weidmann.

Bahor, Stanislav. 2005. Samostanske knjižnice na Dolenjskem. Cistercijanska opatija Stična. *Rast.* 66/1: 93-112.

Bahor, Stanislav. 2005. Samostanske knjižnice (libraries) na Dolenjskem. Franciscans and library of Franciscan monastery Novo Mesto (Frančiškani in knjižnica Frančiškanskega samostana v Novem mestu). *Rast.* 66/3-4 (205): 387-409.

Bahor, Stanislav. 2005. Samostanske knjižnice (libraroes) na Dolenjskem. Kapucini in kapucinski samostan Krško. *Rast.* 66/6: 673-691.

Baird, John Logie. January 21, 1925. Television, a description of the Baird system by its inventor. *Wireless Word and Radio Review.* 533-535.

Baker, Thomas. 1699. *Reflections Upon Learning Wherein Is Shewn the Insufficiency Thereof, and Its several Particulars, and Order to Evince the Usefulness and Necessity of Relevation.* London: A. Bosvile. Reprints: 1709/1710. 5th edition: London 1714; 7th edition: 1738. London; posthumous edition: 1756. London. French translation: 1714. *Traite de l'incertitude des Sciences.* Paris: P. Miquelinb & J. Piget. Italian translation: 1734. *Trattato della Incertezza delle Scienze. Tradato in Italiana.* Venezia, Padova: Francesco Pitteri. Latin translations promoted by Engstler, Joseph Matija. 1759. *Tractatus de Incertitudine Scientiarum, recens ex Italico Latino redditus, Zagrabiae, Typis Cajetani Francis Härl, Anno 1759. Dum Assertiones ex Universa per Philosophia and aula academic Arches-Ducalis Societatis Jesu Collegii Labaci Anno*

Salutis M. DCC. Camile mense Augusto publica propugnarent praenobilis, ac eruditus Dominus Anton. Jos. De Zanetti, Carn. Locopolitanus, E Fund. Thalb et Nobilis, ac Eruditus Dominus. Jugoviz, Carn. Crainburgensis Philosophiae and Secundum Annum Auditores, Ex praelectionibus R. P. Jos. Engestler, è Societate Jesu, A. A. L. L. et of philosophy Doct. Ejusdemque Professor Public & Ordinarii, et examineris, Auditoribus oblati (FSLJ-20 i 4; NUK-GS 4835). Simultaneous edition: 1759. *Tractatus de Incertitudine Scientiarum. Orig. Reflections upon learning Auctore Thoma Baker. In Academia Zagrabensi latinitate Casimir Bedekovich. Dum Assertiones ex Universa per Philosophia and Aula academic Societatis Jesu publice propugnarent praenobilis, ac eruditus Dominus Marcus Krajachich, Croata Gliensis, ex Praelectionibus R. P. Ioannis Bapt. Simunich...* (Dedication to the Count Ivan Patačić of Zaječda (Vanino, 1969, 195)). Anno MDCCLIX mense Augustus. Zagrebiae: Cajetan Francisco Härl.

Balibar, Françoise. 1984. Comments in: Einstein, Albert; Balibar, Françoise. *Galilée, Newton lus par Einstein: Espace et relativité*. Paris: Presses universitaires de France. Translation of Ličer, Matjaž & Likar, Vojislav: 2014. *O posebni in splošni teoriji relativnosti. Einsteinovo branje Galileja in Newtona*. Ljubljana: ZRC SAZU.

Baldi, Bernardino. 1621. *Bernardini Baldi urbinatis quastalae abbatis In mechanica Aristotelis problemata exercitationes: adiecta succincta narratione de auctoris vita (et) scriptis*, Mainz: Johann Albin (Moguntiae: Ioann Albini), 194 pages, 21 cm) (V).

Baldini, Ugo. 2005. *L'Insegnamento Fisico-Matematico*, Padua.

Baraga, France (ed.). 2002. *Historia annua Collegii Societatis Jesu Labacensis (1596-1691)*. Ljubljana: Družina (Family). (original at SI_AS 180 r).

Baraga, France (ed.). 2003. *Letopis Ljubljanskega kolegija Družbe Jezusove (Yearbook of Ljubljana college Society of Jesus) (1596-1691)*. Ljubljana: Družina (Family).

Baraga, France. 1999. Polidor Mantagnana. *Preddvor v času in prostoru*. Preddvor: Zbornik občine (Anthology of municipality). 89–103.

Barancev, A.I. (Баранцев, Андрей Иванович); Urvalov, V.A. (Урвалов, Виктор Александрович, Ленинград). 1986. Tehničke aspekty i značenije radiotelefota B. P. Grabovskogo v istorii televidenija (Технические аспекты и значение радиотелефота Б. Н. Грабовского в истории телевидения, Technical aspects of the significance of the radio-telephoto of B. P. Grabovsky in the history of television). *VIET*. 2: 130-138.

Barba, Alvarez Antonio. 1640. *Arte de los Metales En Que Se Enseña El | verdadero beneficio de los de oro, y | plata por açogue. | El Modo De Fvndirlos Todos, | y como se han de refinar, y apartar | vnos de otros. | Compvesto Por El Licenciado | Alvaro Alonso Barba, natural de la villa de Lepe, en la | Andaluzia, Cura en la Imperial de Potosí, de la | Parroquia de S. Bernardo*. Madrid: Imprenta del Reyno. Reprint: 1729. *Arte de los Metales: en que se enseña el verdadero beneficio de los de oro y plata por azogue ; el modo de fundirlos todos, y como se han de refinar y apartar unos de otros compuesto por Alvaro Alonso Barba ; nuevamente aora añadido, con el Tratado de las antiguas minas de España, que escribió don Alonso Carrillo y Laso. De las antiguas minas de España*. Madrid: Francesco Assensio & Bernardo Peralta. Translations: 1751. *Metallurgie; ou, l'art de tirer et de purifier les métaux, traduite de l'espagnol d'Alphonse Barba avec les dissertations les plus rares sur les mines & les opérations métalliques*. 1-2. Paris: Pierre-Alexandre Le Prieure, with additions from *Philosophical Transactions of the Royal Society*, 1665-1678 and from *Mémoires de l'Académie des Sciences*, 1701-1719 and from *Histoire de l'Académie*, 1727-1728); 1676. *Alvaro Alonso Barba, Eines Spanischen Priesters und hocherfahrenen Naturkündigers Berg-Büchlein: Darinnen Von der Metallen und Mineralien Generalia und Ursprung, wie auch von derselben Natur und Eigenschafft, Mannigfaltigkeit, Scheidung und Fein-machung, imgleichen allerhand Edelgesteinen, ihre Generation etc. außführlich und nutzbarlich gehandelt wird*. Hamburg: Schultze (NUK; V (Valvasor's book); Mayr's selling catalogue of 1678 noted it as "Bergbüchen Darinnen

der Metallen und Mineralien Ursprung"); 1740. *Verhandlung over de metalen, mynen ein mineralen*. Leiden: J., van den Kluis; 1749. *Eines spanischen Priesters und hocherfahren Natur-Kündigers Docimasie oder Probir- und Schmelztz-Kunst... aus dem Frantzösischem inn das Teutsche übersertzt und mit einem Angang... Matthia Godar*. Wien: Trattner.

Bardeen, John. May 15, 1947. Surface States and Rectification at a Metal Semi-Conductor Contact. *Phys.Rev.* 71: 717-727.

Barnadas, Josep Maria. 1986. *Alvaro Alonso Barba, 1569-1662; Investigaciones sobre su vida y obra*. La Paz: Minera Boliviana (Papiro).

Barner, Jakob. 1674. *Prodromus Sennerti novi, seu Delineatio novi medicinae systematis, in quo quicquid a primis seculis in hunc usque diem de arte prodiit, Hippocratis, Galeni, Paracelsi, Helmontii, Sylvii, Willisii, &c. dogmata, ex principiis anatomico-chymicis examinantur*. Augustae Vindelicorum: Theophili Göbelii & Johannis Schönigkii.

Barner, Jakob. 1675. *Jacobi Barneri D. Spiritus vini sine acido, hoc est: In spiritu vini & oleis indistinctè non esse acidum, nec ea propterea à spiritu urinae reverà coagulari, demonstratio curiosa: cum modo conficiendi salia volatilia oleosa, eorumque usu*. Lipsiae: Johannis Fritzschi & Joh. Eriici Hahnii (Seminary Library of Ljubljana)

Bartol, Vladimir. 1961. *Razgovor z atomskim fizikom. Obiski pri slovenskih znanstvenikih*. Ljubljana: Mladinska knjiga (Juvenile books). 101-114.

Bartoli, Adolfo Guisepe. 1879. Dimostrazione di un Theorem relativo alla teoria del raggiamento dato dal Professor R. Clausius: del dott. Adolfo Bartoli. Professore di fisica nell'instituto technico di Firenze. *Nuovo Cimento*. (3) 6: 265-276.

Bartoli, Daniello. 1677. *La tensione e la pressione disputanti qual di loro sostenga (fostenga) l'argentovivo ne'cannelli dopo fattone il Vuoto. Discorso del P. Daniello Bartoli della compagnia di Gesu*. Bologna: Gioseffo Longhi (Auersperg's book).

Bartoli, Daniello. 1681. *Del Ghiaccio e della Coagulatione: trattati*, Roma: Per il Varese. Reprint: Bologna: Recaldini 1682 (Zois' book).

Basilus, Valentinus; Benedikt Nikolaus Petraeus (ed.). 1717. *Das ist Fr. Basilii Valentini, Ordin. Benedict. Chymische Schrifften, Anjetzo Zum Vierdten mahl zusammen gedruckt, Aufs fleißigste aus einigen alten MS gecorrigiret, mit vielen in vorigen Editionen ausgelassenen Passagen und Tractaten, auch etliche Figuren, vermehret, Mit einem generalen vollständigen Register versehen, Und in Drey Theile verfasst: Nebst einer neuen Vorrede, worinnen von Lesung und Critique der Alchymistischen Schrifften ihren Scribenten, neuen Projections - Historien, der Materia Prima Philosophica, dem Leben des Basilii, und was in dieser Edition besonders præstiret worden, einige Nachricht mitgetheilet wird Von Bened. Nic. Petraeo, Med. D. (Zum Beispiel die Ausgabe der Chymischen Schriften von Valentinus)*. Hamburg: Samuel Heyls printed by the heirs of Georg König.

Baš, Franjo. 1934. *Mariborske slike (poročila in slike zbral ter uredil F. J. Mrčenič; slike posnel Ivan Kovačič)*. Maribor: Ljudska tiskarna.

Baumgartner, baron Andreas. 1856. Von der Umwandlung der Wärme in Elektrizität. *Sitzungsberichte der mathem.-naturw. Classe der kais. Akademie der Wissenschaften*, 22 (November): 513. Reprint: 1857. Wien: Karl Gerold's Sohn.

Baumgartner, baron Andreas. 1857. Die Macht der Arbeit (paper read in front of the Austrian Academy of Sciences by its president Baumgartner on 30 May 1855 (Vortrag gehalten in der feierlichen Sitzung der Kaiserlichen Akademie der Wissenschaften am 30. Mai 1855 von Herr Braumgartner, Präsidenten)). *Archiv. Math.* (article no. XVIII of Practical Mechanics (Praktische Mechanik)) 28/3: 329-341.

Baumgartner, baron Andreas. 1857. Sitzung vom 19. November 1857. Vortrag. Von den allgemeinen Eigenschaften der Kräfte in der unorganischen Natur und ihrer Bedeutung in der Naturlehre, *Wien. Ber.* 27: 191-201.

Baumgartner, baron Andreas. 1860. Über (Ueber) Grundgesetze der Naturwissenschaft und ihre Geltung im praktischen Leben: Ein Vortrag gehalten in der feierlichen Sitzung der Kaiserlichen Akademie der Wissenschaften am 30. Mai 1860 von Herr Braumgartner, Präsidenten. *Wien. Ber.* Separate publication. 1860. Vienna: Karl Gerold's Sohn, Hofdruckerei. 32 pages. Also: 1860. *Almanach der K. Akademie der Wissenschaften.* Vienna.

Baumgartner, baron Andreas. 1860. Mittheilungen und Abhandlungen. Über den Grund der scheinbaren Abweichung des mechanischen Wärme-Äquivalentes bei verschiedenen Gasen, *Wien. Ber.* 48: 379–389.

Baumgartner, baron Andreas. 1864. Die mechanische Theorie der Wärme: Vortrag gehalten in der feierlichen Sitzung der Kaiserlichen Akademie der Wissenschaften am 30. Mai 1864 von Herr Braumgartner, Präsidenten. *Archiv. Math.* (Physik XXII) 42/2: 211-226. Simultaneous edition: 1864. Die mechanische Theorie der Wärme, Vortrag der Präsidenten Braumgartner. *Die feierlichen Sitzung der Kaiserlichen Akademie der Wissenschaften am 30. Mai 1864.* Vienna: Karl Gerold's Sohn, 7-30. Separate edition: 1864. Vienna, 30 pages.

de Bausset, Arthur. 1887. *Aerial Navigation.* Chicago: Fergus Printing Company.

Bazala, Vladimir. 1978. *Pregled hrvatske znanstvene baštine.* Zagreb: Nakladni zavod Matice Hrvatske.

Beale, Norman; Beale, Elaine. 1999. *Who was Ingen Housz, Anyway?: a lost genius,* Calne (Wiltshire): Calne Town Council.

Beaudreau, Sherry Ann; Finger, Stanley. 2009. Medical Electricity and Madness in the Eighteenth Century. The Legacies of Benjamin Franklin and Jan Ingenhousz. *Critical Insights Benjamin Franklin* (ed. Jack Lynch). Pasadena/Hackensack: Salem Press, 95-114.

Beccari, Giacomo Bartholomeo (Iacopo, Jacopo Beccaria). 1744. *De quamplurimis phosphoris nunc primum detectis commentaries.* Bononiae: Laelii a Vulpe. Reprints: 1768. *Viri Clarissimi Iacobi Beccariae Comentarium duo, de Phosphoris*

Naturalibus et Artificialibus, ex Actis Bononiensibus Excerpti,... Assertiones Ex universa philosophia.... Biwald... Graecii: Haeredvm Widmanstadii (Theological library (Teološka knjižnica) Maribor. T T4 1/1768; W-1474 now NUK-8227; Erberg's book in 1798; Franjo Orlando used that book for his Jesuitical school in Trieste; FSLJ-8 d 70 with ex libris: «Capucinatorum Laubaci» bind to Schöttl, Gregor. 1769. *Assertionum Ex Universa Philosophia quas in aula Academica Archiducalis Soc. Jesu Labaci ex praelectionibus R.P. Gregorii Schöttl e Soc. Jesu philosophiae professoris publici et ordinarii. Anno M.DCC.LXIX. mense Augusto publice propugnandas suscepit perdoctus dominus Martinus Prenner Carniolus Locopolitanus* (Final exam theses dedicated to count Janez Nepomuk Inzaghi baron Kindberg)). English Translation as Review of that book: 1746. *De quamplurimis Phosphoris nunc primum detectis Commentarius* by Jac. Barthol. Beccario, 1744. (Review) by W. (William) Watson FRS. *Philosophical Transactions.* Volume 44: pp. 81-91.

Beccaria, Cesare (Marquis of Gualdrasco and Villareggio, signed as C.). 1764. Tentativo analitico su i contrabbandi (Analytical attempt about smuggling). *Il Caffè: o sia, Brevi e varj discorsi già distribuiti in fogli periodici (Milano/Brescia of Venetian Republic: Pietro Pizzolato).* volume 1/folio (number) 12: pp. 235-242. Partial Reprints: *Il Caffè,* volume 1/folio (number) 15: 173-175 (second edition of 1766: volume (tom) 1: 207-210)).

Beccaria, Giambattista. 1758. *Dell'elettricismo. Lettere di Giambattista Beccaria de' CC. RR. delle Scuole Pie, Professore di Fisica Sperimentale nella Regia Università di Torino, Membro della Società Reale di Londra, e dell'Accademia delle Scienze di Bologna ec.ec. Dirette al chiarissimo sig. Giacomo Bartolomeo Beccari preside perpetuo, e professore di chimica nell'Istituto di Bologna, membro della Società Reale di Londra, e dell'Accademia delle Scienze di Bologna ec.ec. Coll'appendice di un nuovo fosforo descritto all'illustrissimo (= ll'illmo) sig. conte Ponte di Scarnafigi. Alla sacra reale maestà del Re di Sardegna.* Bologna: Colle Ameno (The book is kept in the library of the Italian Grammar School (gymnasium) in Koper with the bookplate of the local Piarists).

Beccaria, Giambattista. 1753. *Dell' Eletticismo artificiale e naturale libri due, di Giambatista Beccaria, ...* Torino: F.A. Campana. Reprint-Promotion: 1756. *Èmo ... Antonio Andreae Galli Physicas Propositiones. Accedit Tractatio De Artificiali Electricismo Ex Beniamini Franklini Theoria / Quam expolivit, confirmavit, auxitque Joannes Babtista Beccaria. Nuncupat, Et Publice Disputandas Exhibet Facta Omnibus Post Tertium Arguendi Potestate Petrus Franciscus Toti.* Rome: ex Typographia S. Michaelis per Octavium Puccinelli. Translation: 1 June 1772. *Eletticismo artificiale di Giambatista Beccaria delle scuole pie all'altezza reale del signor duca di Chablais.* Torino: Nella Stamperia Reale (Zois' book but not in the modern NUK). Modified Reprint: Beccaria, Giambattista. 1775. *Eletticismo artificiale; Della elettricità terrestre atmosferica a cielo sereno osservazioni di Giambatista Beccaria delle scuole pie dedicate a sua altezza reale il signor principe di Piemonte* (Containing: *Altezza reale -- [Della Eletticità ...] -- Lettera prima. A sua eccellenza D. Angelo Maria Carrone di S. Tommaso -- Lettera II. Al chiarissimo presidente della società reale di Londra ... -- Lettera III. Della elettricità di guazza -- Frontespizio -- [Nuovi sperimenti ...] -- Lettera di Giambattista Beccaria delle scuole pie ... --Lettera II. Al medesimo --*); *Experimenta.* Torino: Vicarius Generalis S. Officii Taurini (two books in Italian language and one in Latin language).

Beccaria, Giambattista (Giacomo Battista). 1769. *Experimenta, atque observationes, quibus electricitas vindex late constituitur, atque explicatur.* Torino: Ex Typographia Regia.

Becher, Johan Jakob. *Chemische Schriften.* Probably the book which Mayr offered in Ljubljana in 1678: Becher, Johan Jakob. 1671. *Experimentum chymicum novum, quo artificialis & instantanea metallorum generatio & transmutatio ad oculum demonstrator,* Francofurti: Sumptibus Joh. Davidis Zunneri. Typis Henrici Friesii.

Becher, Johan Jakob. 1729. *Oedipus chymicus Oder chymischer Rätseldeuter, worinnen derer Alchymisten dunckelste Redens -Arten und Geheimnisse offenbart und aufgelöst warden... Joh. Joachim Becher. Aus dem Lateinischen ins Deutsche*

übersetzt ... zum Druck befördert durch Friederich Roth-Scholtzen, Nürnberg.

Becher, Johan Jakob; Stahl, George Ernst. 1738. *Joh. Joachimi Beccheri ... Physica subterranea : profundam subterraneorum genesin, e principiis hucusque ignotis, ostendens: Opus sine pari primum hactenus et princeps, editio novissima, præfatione utili præmissa, indice locupletissimo adornato, sensuumque & rerum distinctionibus, libro tersius et curatius edendo, opera navavit et specimen Becheriarum, fundamentorum, documentorum, experimentorum, experimentorum, subjunxit Georg. Ernestus Stahl.* Leipzig: Weidmann.

Becquerel, Henri. 1903. *Recherches sur une propriété nouvelle de la matière. Activité radiante spontanée ou radioactivité de la matière.* Paris: Firmin-Didot et Cie.

Bečvářová, Martina. 2014. The role of Czech mathematicians in the Balkans (1850–1900), *Czasopismo Techniczne (Nauki podstawowe) (Technical Transactions (Fundamental Sciences))*, Krakow: Politechnika Krakowska im. Tadeusza Kościuszki. 1 NP (7) pp. 37–57.

Behm, Britta L.; Lohmann, Uta; Lohmann, Ingrid. 2002. *Jüdische Erziehung und aufklärerische Schulreform.* Münster/New York/München/Berlin: Waxmann.

Belhoste, Bruno. 1991. *Augustin-Louis Cauchy. A Biography.* New York: Springer-Verlag.

Belii, Iuriĭ Aleksandrovich (Belyĭ, Юрий Александрович Белый). 1971. *Jogann Kepler.* Moskva: Nauka.

Bellodi, Giuliano; Paolo Brenni (Museo Galileo in Firenze). 2001. The “Arms of the Physicist”: Volta and Scientific Instruments, *Nuova Voltiana* (Pavia: Università Degli Studi; Milano: Editore Ulrico Hoepli), 3: 1-40.

Benedetti, Giannbattista. 1599. *Io. Baptistae Benedicti Partii Veneti philosophi praestantissima speculationem libri in quo mira subtilitate haec tractatu continentur theoremata arithmetica de rationibus operationem perspectiva de mechanicis*

disputat de quibuspan placitis Arist. In quintum Euclidis libra Physica & Mathematica responsa per epistolas. Venetis: Baretium Baretium & Socios.

Benedict XIII (the pope, ed.). 1726. *Index Librorum Prohibitorum*. Nürnberg: Lochner / Prague: Joseph Anton Schilhart.

Benedict XIV (the pope); Ricchini, Tommaso Agostino (eds.). 1758. *Index Librorum Prohibitorum*. Rome: Typographia Rev. Camerae Apostolicae.

Benedik, Metod; Kralj, Angel. 1994. *Kapucini na Slovenskem v zgodovinskih virih*. Ljubljana: Institut za zgodovino cerkve.

Benedik, Metod. 1994. Kapucini v Novem mestu. *Zgodovinski časopis*. 48/2: 195-216.

Benedik, Metod. 2008. *Kapucinski samostan s cerkvijo sv. Ane Škofja Loka (Capuchin monastery with the church)*. Celje: Celjska Mohorjeva družba (Mohor's Society).

Benigar, Ivan. 1870. Experimental-Untersuchungen über die Diffusion von Gasgemengen (Diffusion of gaseous mixtures), *Wien.Ber.* II. 62: 687-698.

Benigar, Ivan. 1873. Počela teorije o razvodu topline (Basic theories of heat transfer). *Programm des k. k. Staats-Ober-Gymnasiums zu Vinkovci (Program of higher Grammar school (gymnasium) at Vinkovci)*. pp. 3-22.

Benigar, Ivan. 1885. Osnutak i razvitak physicalnoga cabinet na kr. gimnaziji zagrebačkoj od godine 1850. do godine 1884. (development of Zagreb Grammar school physics lab from 1850 until 1884), *Program of Grammar school (gymnasium) Zagreb*. pp. 3-16.

Bennet, Abraham. 1 January 1792. A new Suspension of the Magnetic Needle, intended for the discovery of minute quantities of magnetic attraction: also an air vane of great sensibility; with new experiments on the magnetism of iron filings and brass. *Phil.Trans.* 82: 81-98.

Bennett, Willard Harrison. May 1, 1932. Effect of the Target on Breakdown in Cold Emission, *Physical Review*, 40/3: 416-424.

Bennett, Willard Harrison. June 1934. Magnetically Self-Focussing Streams, *Physical Review*, 45/12: 890-897.

Béraud, Laurent (or Bertier, Joseph-Étienne). 1755. *Physique des corps animés, par le P. B****, correspondant de l'Académie royale des sciences*. Paris: Hyppolite-Louis Guérin & Louis-François Delatour & Augustin Martin Lottin. Simultaneous print: *Physique des corps animés*. In: Euler et all. 1755. *Dissertationes selectae Jo. Alberti Euleri, Paulli Frisii, et Laurentii Beraud, qua ad Imperialium Scientiarum Petropolitanam Academiam an. 1755 missae sunt... Disquisitio de causa physica electricitatis ab Academia Scientiarum Imperali Petropolitana praemio coronata in publico Academiae conventu die vi. Septembr. MDCCLV una cum aliis duabus dissertationibus de eodem argumento* [by Paolo Frisi and Laurent Béraud] (*De causa electricitatis, De causa electricitatis dissertation. Theoria electricitatis*). Academia Imperialis Petropolitana. Petropoli/Lucae: Vincent Junctin.

Bernard-Maitre, Henri. 1948. Catalogue des objectas envoyés de Chine par les missionnaires de 1765 a 1786 Henri Bernard S.J. Département de Recherches de l'Université l'Aurore. *Bulletin de l'Université Aurore*. Série III, Tome 9: 119-206.

Bernard-Maitre, Henri. 1949. *Le Père Le Chéron d'Incarville Missionnaire français de Pékin d'après de nombreux documents inédits (Un correspondant de Bernard de Jussieu en Chine)*. Paris: J. Peyronnet (Cathasia: Série culturelle des Hautes Études de Tientsin). Reprint with changed pagination from: 1949. *Archives internationales d'histoire des Sciences*. Tome 2: 333-362, 692-717.

Bernhardt, Jean. 1993. La question du Vide chez Hobbes. *Rev. Hist. Sci.* 46/2-3: pp. 224-239.

Bernik, Francè. 1964. Sto let kulturnega poslanstva. *Slovenska Matica 1864-1964* (ed. Francè Bernik). Ljubljana: Slovenska Matica. 11-32.

Berthollet, Claude-Louis. 1803. *Essai de statique chimique*. Paris: Didot (Z (Zois' book) now NUK-8583).

Beyer, Robert Thomas. 1999. *Sounds of our times: Two hundred years of acoustics*. New York: AIP-Springer.

Bircher, Martin. 1995. The "splendid library" of the Counts of Auersperg in Ljubljana, In: *The German Book 1450–1750: studies presented to David L. Paisey in his retirement* (ed. John L. Flood and William A. Kelly), London: British Library, 285-298.

Birks, John Betteley (ed.). 1962. *Rutherford at Manchester*. London: Heywood & Co. Reprint: 1963. New York: W. A. Benjamin Inc.

Biwald, Leopold. 1767-1768. *Institutiones Physicae* (FSLJ-9 c 12, FSLJ-23 c 42, FSLJ-16 c 18) as *Physica generalis & particularis*. Graz: Widmanstadius (NUK-GS 8188; Joseph Grim's book, then Pfarr u. Kr. Dec. Bibliothek in Marburg, then Študijska knjižnica Maribor now NUK-GS 8158; MINSPT). Reprints: 1769. *Institutiones Physicae: In Vsvm Philosophiae Avditorvm Conscriptae*, Graz: Widmanstadius, second edition. Maria Theresa dedicatio ab Mario comite de Pozzo (Italo Venetiensi) Ex libris Francisci Antoni de Breckerfeld 1771 Conv. Neostad S.P Franciscani / anex (bind to): *Assertationes ex universa* (KKKRS; FSLJ-23 c 31). Reprint: 1774. Graz: Jos. Martin Lechner (bookplate: "Ad usum pater Alani Makoviz Franciscani 1788" in FSLJ-3 h 49-50). Another copy with bookplate "Procuratus a S. Benevolente Philippis (Benvenuto Philippitsch)" (FSLJ-8217-18 – 17, FSLJ-14 – 15 – forma 4, FSLJ-17 1 14-15).

Biwald, Leopold. 1772. *Tentamen publicum physicum ex praelectionibus L. Biwald. Defendent: de Zois ab Edelstein (Edelskini) Carolus, Carniol. Labaci. Periz Thomas, Gorit Sämpas (Šempas), Ploch Anton, Stirius Pettov (Ptuj),...* altogether sixteen students of Biwald, Joseph de Catharin, and Leopold Plappart. Graz: Widmanstadius. Bind to German translation of Aepinus' Petersburg Academy report (1758) in French language dealing with the similarity of the electrical and magnetic forces and

the new experiments with electricity of tourmaline: Aepinus, 1771. *Turmalin*, Petersburg (FSLJ- 2 h 99).

Biwald, Leopold; Taupe, Karl; Wolf, Joannes Nepomuk. August 1778?. *Sätze und Aufgaben aus unterschiedenen Theile der Größenlehre, welche mit Einstimmung / Ihro Magnifizenz des hochwürdigen, hochgelehrten / Herrn Rectorn der hohen Schule, des hochedelgebohrnen, und hochgelehrten / Herrn K. K. Vorsteher der philosophischen Facultät, / des wohlgedelgebohrnen, ansehnlichen, und hochgelehrten Herrn Dechant, und aller Mitglieder gedachter Facultät, in dem großen Hörsaaale auf der hohen Schule zu Grätz im Monat August öffentlich beweisen, und vertheidigen wird der hoch= und wohlgebohrne Freyherr Karl Zois von Edlstein aus dem erzherzogl. Adelichen Collegium*. Graz (W-1506 today NUK-8281). 7 leaves, 12 pages. Bind to partial reprint of Nicolas Bion's. sine dato (1778?). *Gründliche Anweisung zum gebrauch, und Nutzen des Proportional Zircels aus der mathematische Werkschule des Herrn Nicolas Bion*. Graz: Windmanstads Erben (ad-ligate to W-1506 now NUK-8282).

Bianchi, Jacob Franz von (Giacomo Bianchy, Jacques). 1768. *Auserlesenes Cabinet Phisikalisch- und Mathematischer Instrumenten wie auch das Merkwürdigste vom Barometre und Thermometre nebst einer neu erfundenen Wetterglas- und Vergleichungstabelle der Reaumur, Fahrenheit und de l'Isle Thermometres [Jacob von Bianchy]*. 1-2. Wien: Schulzischen Schriften (Propriety seal of City study library (Mestna študijska knjižnica) Maribor, now University of Maribor library: UKM: R 36336).

Bianchini, Giovanni Fortunato. 1754. *Gio. Fortunato Bianchini, medico, Osservazioni intorno all'uso dell'elettricitè celèste e sopra l'origine del fiume Timavo, riportate in due lettere*. Second letter: *Osservazioni intorno al fiume Timavo scritte in una lettera al Nobile ed Erudito Signore Guido Conte Cobenzl*. Venezia: G. B. Pasquali, pp. 41-81. Second letter: pp. 41-81 (Zois' library, today NUK-GS I 7008).

Bidermann, Hermann Ignaz. 1882. *Zur Geschichte der Uskoken in Krain*. *Archiv für Heimatkunde von Franz Schumi*. Laibach. 1/9: 129-154.

- Bidermann, Hermann Ignaz. 1884 (1887). Zur Geschichte der Uskoken in Krain. *Archiv für Heimatkunde von Franz Schumi*. Laibach. 2: 174-207.
- Bidwell, Shelford. 10 February 1881. Tele-Photography, *Nature*, 23/ 589. 344-346.
- Bidwell, Shelford. 4 June 1908. Telegraphic Photography and Electric Vision, *Nature*, 78/2014: 105-106.
- Bittner, Lotte. 1949. *Geschichte des Studienfaches der Physik an der Universität Wien in den letzten hundert Jahren*. PhD Dissertation, Viennese University (Universität Wien).
- Bizant, Milan. 1998. Marijine kongregacije v ljubljanskem jezuitskem kolegiju. *Jezuitski kolegij v Ljubljani (1597-1773): Anthology* (ed. Rajšp, Vincenc; Juhant, Janez). Ljubljana: ZRC SAZU / Provincialat slovenske province Družbe Jezusove / Inštitut za zgodovino Cerkev Teološke fakultete, 137–156.
- Blaserna, Pietro; Mach, Ernst; Peterin, Julius. 1859. Über elektrische Entladung und Induction, *Wien. Ber.* 37: 477-524.
- Blinc, Robert, Žekš, Boštjan. 1974. *Soft Modes in Ferroelectrics and Antiferroelectrics*. Amsterdam: North Holland Publishing Company.
- Blinc, Robert; Južnič, Stanislav; Žumer, Slobodan; Rutar, Vinko; Seliger, Janez. 1980. ^{87}Rb Spin-Lattice Relaxation in the Incommensurate Phase of Rb_2ZnCl_4 . *Phys. Rev. Letters*, 44/9: 609–612.
- Blum, Paul Richard. 2002. Ubi natura facit circulos in essendo, nos facimus in cognoscendo: der demonstrative Regress und der Beginn der modernen Wissenschaft bei katolischen Scholastikern. *Presenza dell'aristotelismo padovano nella filosofia della prima modernità. Colloquio internazionale in memoria di Charles B. Schmitt (Padova, 4 - 6 September 2000, ed. Piaia, Gregorio)*. Roma. pp. 371-392.
- Boas Hall, Marie. 2002, *Henry Oldenburg: Shaping the Royal Society*, Oxford: University Press.
- Boethius, Anicije Manilaj Severin (Anicius Manlius Severinus). Before 6 March 1491. *De philosophia consolata cum commento Pseudo-Thomae Aquinas*. Argentinae (Strasbourg): Johann Prüss (NUK-4567; ST).³⁵⁷² Reprint: 1521. *De philosophia consolata*. Viennae (NUK-963, Bookplate: *Johannis Stephani Floriantschich de Grienfeldt*). Reprint: 1682. *Anicii Manlii Torquati Severini Boetii De consolatione philosophiae; libri V...* Labaci: Joan Baptista Mayr (KSSKL-28, KSSKL-29; ER, NMLJ-1066; NUK-DS 280192). 1733. Vienna: Voigt (NUK-1082).
- Bogoljubov, Aleksej Nikolaevič (Алексей Николаевич Боголюбов). 1983. *Matematiki mehaniki. Biografičeskii spravočnik*. Kiev: Naukova dumka.
- Bogoljubov, Aleksej Nikolaevič. 1984. *Robert Hooke*. Moscow: Nauka.
- Bohn, Johann Conrad. 1865. Ueber das Farbensehen und die Theorie der Mischfarben, *Ann.Phys.* 201/5: 87-118.
- Bohn, Johann Conrad. 1867. Ueber negative Fluorescenz und Phosphorescenz, *Ann.Phys.* 130 (206/3): 367-392.
- Bohn, Johann Conrad. 1868. Ueber negative Fluorescenz, *Ann.Phys.* 133 (209/1): 165-174.
- Bohr, Niels (Нильс Бор). 1970, 1971. *Selected scientific papers 1-2 (Избранные научные труды: в двух томах/ Izbrannye nauchnye trudy: v dvukh tomakh)* (Edited by I.E. Tamm, V.A. Fok, B.G. Kuznetsov (под редакцией И.Е. Тамма, В.А. Фока, Б.Г. Кузнецова)). Moscow: Nauka.
- Bohr, Niels. October 1985. Niels Bohr: An album of photographs of Bohr at work and at home. *Physics Today*, 38/10: 23-27.
- Bojc, Etbin. Šole in učiteljstvo na slovenskem Štajerskem pred sto leti (prispevek za šolsko zgodovino ob 200-letnici terezijanskih šol). *Časopis za zgodovino in narodopisje*, 1971, 42/7: 85-150.

³⁵⁷² Gspan, Badalić, 1957, 118.

Bokšan, Slavko. 1932. *Nikola Tesla und sein Werk: und die Entwicklung der Elektrotechnik, der Hochfrequenz- und Hochspannungstechnik und der Radiotechnik: mit 70 Abbildungen im Text*. With a foreword by Franz Kiebitz. Leipzig/Vienna/New York: Deutscher Verlag für Jugend und Volk. Extended Serbian translation of Bokšan: 1946. *Nikola Tesla i njegovo delo: osnovi elektrotehnike, visokih frekvencija i radiotehnike*. Beograd: Društvo "Nikola Tesla" za unapređenje nauke i tehnike.

Von Bolton, Werner. 1905. Das Tantal, seine Dartstellung und seine Eigenschaften. *Z. Elektrochem.* 11: 45-51.

Boltzmann, Ludwig. 1866. Über die mechanische Bedeutung der zweiten Hauptsatzes der Wärmetheorie. *Wien.Ber.* 53: 195-220.

Boltzmann, Ludwig. 1867. Über die Anzahl der Atome in den Gasmolekülen und die innere Arbeit in Gasen. Vorgelegt in der Sitzung am 28. November 1867 (28 November 1867 assembly). *Wien.Ber.* 56: 682–690, 841.

Boltzmann, Ludwig. 1868. Studien über das Gleichgewicht der lebendigen Kraft zwischen bewegten materiellen Punkten. *Wien.Ber.* 58: 517–560. Reprint: *Wissenschaftliche Abhandlungen* 1909, 1: paper no. 5.

Boltzmann, Ludwig. 1868. Lösung einer mechanischen *mechanischen* Problems. *Wien.Ber.* 68: 1035-1044. Also in: *Wien. Anz.* Band I (Volume 1): 97-105.

Boltzmann, Ludwig. 1871. Über das Wärmegleichgewicht zwischen mehratomigen Gasmolekülen. *Wien.Ber.* 63: 397–418. Reprint: *Wissenschaftliche Abhandlungen* 1909. Volume 1, paper 18.

Boltzmann, Ludwig. 1871. Einige allgemeine Sätze über Wärmegleichgewicht, *Wien. Ber.* 63: 679-711.

Boltzmann, Ludwig. 1871. Analytischer Beweis des 2. Hauptsatzes der mechanischen Wärmetheorie aus den Sätzen über das Gleichgewicht der lebendigen Kraft. *Wien.Ber.* 63: 712-732.

Boltzmann, Ludwig. 1871. Boiling points of organic bodies, To the editors of the Philosophical Magazine and Journal (criticism of F. Burden's paper published there in June 1871), *Phil. Mag.* 42/281 (2): 393. Reprint: *Wissenschaftliche Abhandlungen* 1909. 1: 199.

Boltzmann, Ludwig. 1871. Zur Priorität der Auffindung der Beziehung zwischen dem zweiten Hauptsatz der mechanischen Wärmetheorie und dem Prinzip der kleinsten Wirkung. *Ann.Phys.* 143: 211-230.

Boltzmann, Ludwig. 1872. Über das Wirkungsgesetz der Molekularkräfte. *Wien. Anz.* 9: 134. *Wien.Ber.* 66 (1872): 213-219. Reprints: 1872. *Ann. Phys.*; *Wissenschaftliche Abhandlungen* 1909, 1: 309-215.

Boltzmann, Ludwig. 1872. Weitere Studien über das Wärmegleichgewicht unter Gasmolekülen. *Wien.Ber.* II 66: 275–370.

Boltzmann, Ludwig. 1875. Über das Wärmegleichgewicht von Gasen, auf welche äussere Kräfte wirken. *Wien.Ber.* II. 72: 427-457. *Wien. Anz.* 12: 174 (14 October 1875). Translation: *Phil.Mag.* 50 (4): 495.

Boltzmann, Ludwig. 1875. Bemerkungen über die Wärmeleitung der Gase: (vorgelegt in der Sitzung am 14. October 1875). *Wien.Ber.* II. 72: 458–470. Abridged: 1875. *Wien.Anz.* 12: 174. Reprint: 1876. *Ann.Phys.* 157: 457-479. Abridged Translation: 1875. *Phil.Mag.* 50 (4): 495-496.

Boltzmann, Ludwig. 1880. Zur *Theorie* der *Gasreibung* I. *Wien.Ber.* 81: 117–158. Reprinted in his: 1909. *Wissenschaftliche Abhandlungen.* 2: 388-430. Continued in 1882 in *Wien.Ber.* 84: 40-135, and *Wien.Ber.* 84: 1230-1263. Abridged: 1880. *Anzeiger der k. Akademie der Wissenschaften* (Wien) 17: 11; 17: 213; 18: 272.

Boltzmann, Ludwig. 1895. Josef Stefan. Rede gehalten bei der Enthüllung des Stefan-Denkmal am 8. Dez. 1895. Reprint 1905: *Populäre Schriften*. Leipzig: Barth, 92-103.

Boltzmann, Ludwig. 1909. *Wissenschaftliche Abhandlungen*. 1-3. Leipzig: Johann Ambrosius Barth.

Boncelj, Josip (Josef). 1958. Jožef Stefan und seine Tätigkeit auf dem Gebiet der Elektrotechnik. *Elektrotechnik und Maschinenbau* (Zeitschrift der Österreichischen Verbandes für Elektrotechnik), 75/24: 666-674. Simultaneous separate print (Sonderdruck der Zeitschrift). Translation: 1960. Jožef Stefan and his work in the field of electrical engineering (Jožef Stefan in njegovo delovanje na področju elektrotehnike, extended reprint from the journal *Elektrotehniški vestnik* (Electrotechnical News)). Ljubljana: Electrotechnical Education of Slovenia (Elektrotehniška prosveta Slovenije).

Bonča, Janez; Prelovšek, Peter; Ramšak, Anton; Sarben Sarkar (eds.). 2001. *Open Problems and Strongly correlated Electron Systems*. Dordrecht; Springer Netherlands / Boston: Kluwer, Proceedings of the NATO Advanced Research Workshop, Bled, Slovenia, 26-30 April 2000, NATO Science II, Mathematics, physics, and chemistry; volume 15.

Bondyopadhyay, Kumar Probir. January 1998. W. Shockley, the Transistor Pioneer - Portrait of an Inventive Genius. *Proc. IEEE*. 86/1: 191-210.

Bondyopadhyay, Kumar Probir. January 1998. Under the Glare of a Thousand Suns - The Pioneering Works of Sir J. C. Bose. *Proc. IEEE*. 86/1: 218-234.

Bonora, Lucio; Manzato, Eugenio; Sartor, Ivano. 2000. *Treviso cristiana: 2000 anni di fede: percorso storico, iconografico, artistico nella Diocesi*. Treviso: Diocesi di Treviso.

Borchardt, Curt. 1930. Historischen Daten aus der Vorgeschichte des Fernsehens (Historic Dates determining prehistory of TV). *Fernsehen*. 1: 94-95.

Borchers, Wilhelm. 1897. *Entwicklung, Bau und Betrieb der elektrischen Öfen zur Gewinnung von Metallen, Carbiden und anderen metallurgisch wichtigen Produkten*, Halle a.S.: W. Knapp. Translations: 1908. *Electric Furnaces (Die elektrischen Öfen)*. The production of heat from electrical energy and the construction of electric

furnaces ... Translated by Henry George Solomon. London: Longmans & Co.; 2005. *Design & Construction of Electric Furnaces*, Watchmaker Publishing. Reprint: 2005. Merchant Books.

Borelli, Giovanni Alfonso. 1686. *De vi percussiois*. Leyden: Peter van der Aa.

Borisov, Vasilij Petrovič (Василий Петрович Борисов). 2002. Izobretenje vakuumnoga nasosa i krušenije dogmi "bojayni pustoti". *VIET*. 4: 650-671.

Born, Ignaz von. 22 October 1771. Review of N. Poda's book in Vienna. *Prager gelehrte Nachrichten*. 4: 57-59.

Bossi, Luigi. 1797. *Elogio storico del conte commendatore Gian-Rinaldo Carli* (With a portrait and a bibliography). Venezia: Carlo Palese.

Bossi, Luigi. 7 August 1823. *Elenci delle memorie scientifiche e letterarie. Recitate nelle aduananze dell'imperiale regio Istituto del regno lombardo-veneto delle Scienze, lettere ed arti Lombardo-Veneto*. Milano.

Bošković, Rudjer Josip. 1745. *A.M.D.G. De viribus vivis dissertatio habita in Collegio Romano Soc. Jesu a PP. ejusdem Societatis die 6.: mense Septembri: anno 1745*. Rome: Komarek. Franz Ginhör's promotion of Bošković's viribus vivis together with Franz Gusman Franz Güssmann (Güsmann, Gusman) and the later Jesuit rector in Vienna, Graz and Linz Joseph Gundl: 1752. *Dissertatio de viribus vivis auctore R. P. Josepho Rogerio Boscovich e S. J., honoribus... dom. Carl. de Reuttern, dedicata, dum in... universitate viennensi promotore R. P. Franc. Gindhör e S. J.... Suprema art. liberal. et Philosophiae laurea insignetur*. Viennae: Kalliwoda (NUK-24052).

Bošković, Rudjer Josip. 1749. *Sopra il turbine che la notte tra gli XI, e XII Giugno del MDCCXLIX danneggiò una gran parte di Roma / dissertazione del P. Ruggiero Giuseppe Boschovich...; dedicata a ... cardinale Silvio Valent*. Roma: Niccolò & Marco Pagliarini (Zois' book now NMLJ-K 4069).

Bošković, Rudjer Josip. 1755. *De litteraria expeditione per pontificam ditionem ad dimetiendos*

duos meridiani gradus et corrigendum mappam geographic jussu, et auspiciis Benedicti XIV Pont. Max suscepta a Patribus Societ. Jesu Christophoro Maire et Rogerio Josepho Boskovic, Romae, (J-488 not noted by Wilde, now NUK-4243 with Propriety entry: "Inscriptus Catalogo Bibliotheca Philosophici Coll. Labac. S.J. 1758 a P. Bernardino Erber"). Insertur Catalogo Bibliotheca Philosophica Coll. Labaci S. J. 1758. A S. Bernardino Erber). Reprints: 2nd edition 1757. Bonnoniae; 3rd edition 1776. Viennae. Suplemented French Translation: 1770. Voyage astronomique et géographique. Paris.

Bošković, Rudjer Josip. 1757. *Elementorum universae mathesos. T. III. Tom. I. cont. geometriam planam, arith. vulg. geometriam solid. trigon. planam & sphaer. T. II. algebr. finitam. T. III. sectionum conicarum elementa nova quadam methodo concinnata & dissertationem de transformatione locorum geometricorum, ubi de continuitatis lege, ac de quibusdam infiniti mijsteriis. Editio prima.* Venetiis: Petrini (NUK-4125).

Bošković, Rudjer Josip. 1758. *Theoria philosophia naturalis redacta ad unicam legem virium in natura existentium.* Viennae; Reprints: 2nd edition 1763. Venetiis: Remondiana (Erberg-XCVII/WIII now NMLJ 12262; J-421 for W-1418 now NUK-8179 or NUK-8180 without a Jesuitical ex-libris); Biwald's promotion: 1765. *Assertiones ex universa philosophia, ... Universitate Graecensi, Anno Salutis M.DCC.LXXV. Mense Augusto die_ publice propugnandas susceperunt Perillustris Rever. ac Perdoctus Dominus Maximilianus Chiolich de Levensperg, S.R.I.E. Dalmata, Patricius Segniensis. Sub praesidio Admodum Rev. et Clariss. Domini Leopoldi Biwald, AA. LL. & Philosophiae Doctoris, Physic. Profes. publici & ordinarii.* Graz; 1765. Paris; Promoted by Pogrietschnig, Janez Krstnik in 1768: *Theoria Philosophiae Naturalis, redacta ad unicam legem virium in natura existentium auctore P. Rogerio Josepho Bošković Societatis Jesu, nunc an ipso Perpolita, et austa, As a plurimis paecedentium editionum mendis expurgata. Editio Veneta prima ipso Auctore Praesente, et Corrigente.* Venetiis: Ex Typographia Remondiniana. *Superiorum Permissu, ac Privilegio. Assertiones ex Vniversa Philosophia, quas in Archi-ducali, et Academico Societatis Jesu Gymnasio Labaci. Anno*

M.DCC.LXVIII. Mense Augusto, die_ Publice Propugnandas Praenobilis, ac Perdoctus Dominus Petrus Antonius Modesti, Carnilous Labacensis. Ex praelectionibus R.P. Ioannis Baptistae Pogrietschnig e Societate Jesu, Philosophiae Professoris Publici, et Ordinarii. Labacii (Provincial Museum of Kočevje-accession no. 705 copy dedicated to the Provincial Governor Henrik Auersperg; FSLJ-10 b 70 with propriety entry: "Constituenti conv(entum) Labaci 1771 Libri parati sequentes: Boskovic tom 1", dedicated to Henrici am Auersperg bind in carton ornamented by flowers without marginal notes, bind to Modesti's exam at Pogrietschnig's class in 1768); 5: 1974. Zagreb: Liber.

Bošković, Rudjer Josip, S.J. 1765. Estratto del Trattato astronomico del sig. de La Lande (on 1 April 1765). *Il Caffè: o sia, Brevi e varj discorsi già distribuiti in fogli periodici (Milano/Brescia of Venetian Republic: Pietro Pizzolato) folio (number) 31: 344-349.*

Bošković, Rudjer Josip, S.J. 1765. *Abhandlung von den verbesserten dioptrischen Fernröhren, aus den Sammlungen von Instituts zu Bologna sammt einem Anhang des Übersetzers C. S. (Scherffer) S.J.* Wien: Trattner (NUK-8481 with Gabriel Gruber's Propriety entry for Carniolan society for agriculture and useful arts: "Zur Mechanic").

Bošković, Rudjer Josip, S.J. 1767. *Dissertationes quinque ad Dioptricam pertinentes* (Zois' book now NUK-8157) not Bošković. 1767. *Verbesserrte Dioptrischen Fernröhren* (NUK-8481).

Bošković, Rudjer Josip, S.J. 1765. Lettera del P. Bošković sugli principi, su'quali si possono appoggiare le Regole pratiche per la misura dell'acque, ch'escono dalle aperture, e corrono per gli alvei. In: Lecchi, Giovanni Antonio. *Idrostatica.* 3/1: 319-345.

Bošković, Rudjer Josip, S.J. 1980. *Ruggerio Giuseppe Bošković, Lettere a Giovan Stefano Conti.* Florence: Leo S. Olschki Editore.

Boudon, Jacques Oliver. 2006. Marmont, gouverneur général des Provinces illyriennes. *Napoleon na Jadranu. Napoléon dans l'Adriatique*

(ed. Šumrada, Janez). Koper/Zadar: Annales. 221-232.

Bowers, Brian. 1998. *Lengthening the day*. Oxford/New York/Tokyo: Oxford University Press.

Bowers, Brian. 2001. *Sir Charles Wheatstone FRS 1802-1875*. London: The Science Museum.

Bowers, John. 1970. *Western medical pioneers in feudal Japan*. Baltimore: Published for Josiah Macy Jr. Foundation by Johns Hopkins Press.

Boyle, Robert. 1660. *New Experiments Physico-Mechanical, Touching the Spring of the Air, and its effects; Made, for the Most Part in a New Pneumatical Engine...* Oxford. Translation: 1682. *Experimentorum novorum physico-mechanicorum continuatio secunda, in qua experimenta varia tum in aere compresso, tum in factitio instituta circa inquem, animalia, etc. una cum descriptione machinarum continentur*. Geneva: Tournes (W-1420 now NUK-GS 8340).

Boyle, Robert. 1670. *Paradoxa hydrostatica novis experimentis...* Rotterdam: Leers.

Boyle, Robert. 1670. *Nova experimenta pneumatica de respirationem spectantia*. *Phil.Trans.* no. 62-63, 8 August 1670, and 12 September 1670. Separately printed English translation: 1670. *New pneumatical experiments about respiration*. London: J. Martin.

Boyle, Robert. 1675. *Nova experimenta pneumatica respirationem spectantia* bind to Boyle's *Exercitationes de atmosphaeris corporum consistentium: deque mira subtilitate, determinata natura, et insigni vi effluuorum*. Bologna: Petronij de Ruinettis (Gerbec's library, today in SKLJ).

Boyle, Robert. 1680. *Tractatus scripti honoratissimo Roberto Boyle nobili Anglo, e Societate Regia. Ubi I. Mira Aeris (etiam circa Calorum) rarefaction detecta. II Observata Nova curca durationem virtutis elasticae aeris expansi. III Experimenta nova de condensatione aeris solo frigore facta, ejusque compressione sine machinis. IV. Ejusque quantitatis aeris rarefacti & compressi mire discrepans extensio*, Geneva (=Colloniae Allobrogum): Samuel de Tournes.

Boyle, Robert. 1677. *Roberti Boyle, nobilissimi Angli, et Societatis Regiae dignissimi socii, Opera varia: quorum posthac exstat catalogus, cum indicibus necessariis & multis figuris aeneis*. Geneva (=Colloniae Allobrogum): Samuel de Tournes. Reprint: 1680. *Roberti Boyle, Nobilissimi Angli, Et Societatis Regiae Dignissimi Socii, Opera Varia, Quorum posthac exstat Catalogus Cum Indicibus necessariis, multisque Figuris Aeneis. 1. Nova experimenta physico-mechanica de vi aëris elastica, & ejusdem effectibus 2. Defensio doctrinae De elatere et gravitate aeris... 3... Experimentum nova de condensatione aeris... 4... fluiditatis et firmitatis... 5. Chymista scepticus... 6. Paradoxa hydrostatica...* Geneva: Tournes, 12 parts in 2 volumes (M; Gerbec's library, today in SKLJ).

Boyle, Robert. 1680. *The Aerial noctiluca, or some New phaenomena and a process of a factitious self-shining substance, imparted in a letter to a friend, living in the country, by the honourable Robert Boyle, ...* London: Printed by Thomas Snowden, and sold by Nath. Ranew. Translations: 1682. *Die luftige Noctiluca (aeria), oder Etliche Neue Phoenomena, sampt einer Anleitung allerhand Phosphoros und selbst-scheinende Wesen zu zubereiten*. Hamburg: Gottfried Schultze; 1693. *Noctiluca Aeria Sive Nova Qvædam Phænomena in Substantiæ Factitiæ sive Artificialis, Sponte Lucidæ productione observata : Amico cuidam rure agenti Epistolicè communicata. Vnâ adnectuntur Ejusdem Substantiæ Processus. Atque Experimenta Nova et Observata facta in Glacialem Noctilucam. Quibus adjicitur Paradoxon Chymicvm*. Geneva: Samuel de Tournes.

Boyle, Robert. 1965-1966. *The works*. I-VI (ed. Thomas Birch). Hildesheim: Georg Olms Verlagbuchhandlung.

Boyle, Robert. 1999, 2000. *The Works...* (ed. Hunter; Davis). London: Pickering & Chatto.

Boyvin, Jean Gabriel. 1681. *Philosophia Scoti a prolixitate et subtilitas ejus ab obscuritate libera et vindicata: I. Logica; II. Physica; III. Metaphysica; IV. Philosophia moralis*, 4 vols, Paris: Edmond Couterot (FSLJ-7 e 55-56). Reprint: 1701. *R. P. F. Joannis Boyvin ord. min. observant) Philosophia Scoti a prolixitate, & subtilitas eius Opus*

philosophicorum studentibus sic attemperatum. Ut in illo habeant ad manus philosophiae Scoti integritatem, & profunditatem planam. 1-4, Venetiis: Gaspar de Storti (KSSKL-Loka S 16-19, 312 pages).

Boyvin, Jean Gabriel. 1734. *Theologia Scoti a prolixitate, & subtilitas eius Opus Theologicum... Boyvin. In Provincia Franco Parisina strict. Observ. Lectore Theol...* Venezia: Hieronimus Savioni (NUK-13470).

Bragg, William Lawrence. 1944. *The history of X-ray analysis.* London: Longmans Green & Co.

Brambilla, Elena. 1987. *Le professioni scientifico-tecniche a Milano e la riforma dei Collegi privilegiati (sec. XVII–1770)*, in G. Barbarisi (ed.), *Ideologia e scienza nell'opera di Paolo Frisi (1728–1784)*, 2 vols., Milano, I: 345–446.

Brambilla, Elena. 2000. *Scientific and Professional Education in Lombardy, 1760–1803: Physics between Medicine and Engineering*, in: *Nuova Voltiana. Studies on Volta and his Times*, vol. I, ed. by F. Bevilacqua e L. Fregonese (Proceedings of the International Congress for the Bicentenary of the Invention of the Battery, Pavia, 11-13 dicembre 1998), Pavia, Università degli Studi di Pavia-Hoepli, 2000, pp. 51–99.

Bramer, Benjamin. 1617. *Kurze Meynung de vacuo, oder lährem Orte, neben andern wunderbaren und subtilen Quaestionen: deszgleichen Nicolai Cusani Dialogus von Wag und Gewicht, aus dem Lateinischen verteutscht.* Marpurg: Paul Egenolff.

Bratti, Ivan. 1590. *Discorso della vecchia et nuova medicina, nel quale si ragiona delle cose ritrovate à nostri secoli, & particolarmente dell'oro artificiale.* Venezia: Nicolò Meietti. 2: 1592. Venezia: Paolo Meietti.

Brande, William Thomas. 1814. *The Bakerian lecture: On some new Electro-Chemical Phenomena.* *Phil. Trans. Roy. Soc.* 104: 51-61 (read on 25 November 1813). Simultaneous prints: 1814. London: W. Bulmer and Co. on 13 pages and one leaf of plates; XXII. *On some new electro-chemical phœnomena.* *Phil. Mag.* 44/196 (181408): 124-130.

Brander, Georg Friedrich. 1769. *Kurze Beschreibung einer ganz neuen Art einer Camerae Obscurae ingleichen eines Sonnen Microscops welches man bequem aller Orten hinstellen und ohne Verfinsterung des Zimmers gebrauchen kann womit auch allerley Objekte auf eine sehr leichte Art in einer selbst beliebigen Größe gezeichnet und aufgerissen werden können,* Augsburg: Eberhard Kletts seel. Wittib (FSLJ-8 e 88).

Brander, Georg Friedrich (translator); Musschenbroek, Jan van; Thenn, Johann Christoph; Lambert, Johann Heinrich. 1769. *Beschreibung der doppelten und einfachen Luftpumpe: nebst einer Sammlung von verschiedenen nützlichen und lehrreichen Versuchen, welche man mit der Luftpumpe machen kan; Aus dem Französischen übersetzt und mit vielen neuen Zusäzen und Kupfern vermehret.* (French original: *Description de nouvelles sortes de machines pneumatiques tant doubles que simples avec un recueil de plusieurs expériences que l'on peut faire avec ces machines*). Augsburg: Kletts.

Brander, Georg Friedrich. 1774. *G.F. Branders Kurze Beschreibung einer kleinen Luftpumpe oder Cabinet Antlia: nebst einer Anweisung wie man mit den Stücken, welche meistens dazu gegeben werden, verfahren, und die Versuche anstellen soll.* Augsburg: Eberhard Kletts sel. Wittib (FSLJ-8 e 88).

Braun, Karl Ferdinand. 1874. *Ueber die Stromleitung durch Schwefelmetalle (On the current conduction in metal sulphides).* *Ann. Phys.* (2) 153 (of all volumes 229), issue no. 12: 556-563.

Braun, Karl Ferdinand. 1878. *Bemerkungen über die unipolare Leitung der Flamme,* *Ann. Phys.* 3: 436-447.

Braun, Karl Ferdinand. 1878. *Ueber unipolare Elektrizitätsleitung.* *Ann. Phys.* 4: 476-484.

Braun, Karl Ferdinand. 1896. *Ueber die Leitung elektrisirter Luft.* *Ann. Phys.* 59: 688-692.

Braun, Karl Ferdinand. 1897. *Ueber ein Verfahren zur Demonstration und zum Studium des zeitlichen Verlaufes variabler Ströme.* *Ann. Phys.* 60: 552-559.

Braun, Karl Ferdinand. 1898. Zeigen Kathodenstrahlen unipolare Rotation? *Ann. Phys.* 65: 368-371.

Bregač, Špela. 2006. *Literarna preteklost Novega mesta v obdobju starejše književnosti*, PhD dissertation at University of Ljubljana (Doktorat na Ljubljanski univerzi) (supervisors: Grdina, Igor; Granda, Stane). Ljubljana.

Breislak, Scipion. 1823. Sulla detonazioni dell'isola di Meleda. 24 April 1823. *Elenci delle memorie scientifiche e letterarie. Recitate nelle aduananze dell'imperiale regio institut odi science, lettere e arti Lombardo-Veneto*. Milano.

Brewster, David. 1846. On the Decomposition and Dispersion of Light within Solid and Fluid Bodies. *Transactions of the Royal Society of Edinburgh*, 16/2: 111-121. Translation: 1848. Ueber die Zerlegung und Zerstreung des Lichts innerhalb starre und flüssiger Körper, *Ann.Phys.* 149 (73/5): 531-548.

Bright, Arthur Aaron. 1949. *The electric-lamp industry technological change and economic development from 1800 to 1947*. New York: Macmillan Co.

Brisacensis, Gervasius. 1699. *Cursus philosophicus brevis et clara methodo in tres tomules distributus; auctore P. F. Gervasio Brisacensi, Ordinis fratrum minorum Capucinatorum Provinciae Hungariae. Tomulus primus, Logica. Tomulus secundus octo libros Physicorum, seu Physicam universalem. Tomulus tertius, complectens libros de coelo, de generat., de meteoris, de animae, seu Pyhysicam particularem et Metaphysicam*. Coloniae Agrippina: Joan. Schlebusch (NUK-4615). Reprint: 1711 (NUK-4956; KSMA).

Brixianus, Fortunatus. 1738, 1739. *Elementa mathematica in quatuor Tomos digesta. Tomus I. Algebrae Synopsin, generalem proportionum doctrinam, ac utriusque progressionis theoriam, & praxim continens. T. II. in quo linearum atque planorum symptomata demonstrantur. T. III. Geometriam solidorum continens. T. IV. In quo sectionum canicorum, solidorum ex earum revolutione genitorum, ac figurarum*

isoperimetrarum symptomata demonstrantur, precipuaque elementaris Geometriae Problemata resolutur. Brescia: Rizzardi (NUK-12070). Reprint: 1756. Brescia (FSNM).

Brixianus, Fortunatus. 1749. *Philosophia mentis methodice... I. Logicam. II. Metahysicam*. Brescia: Rizzardi (NUK-4399).

Brixianus, Fortunatus. 1735, 1736. Reprints: 1745-1747. *Philosophia... Mechanica III Vol 3*. Brixiae: Rizzardi (FSNM). Reprint: 1751, 1752. *Philosophia Sensuum Mechanicum Methodice Tractata at que ad usus Academicos accomodata opera & studio. Tomus primus physicam generalem continens. Tomus secundus physicam particularum complectens. Secundis cursis P.F. Fortunati A. Brixia ord. minor. S. Francisci Prov. Brixia. I- III*, Brescia: Rizzardi (FSNM; NUK-8150).

Brockliss, Laurence W.B. 1995. Pierre Gautruche et l'enseignement de la philosophie de la nature dans les collèges jésuites français vers 1650. *Les Jesuites à la Renaissance. Système éducatif et production du savoir* (ed. Luce Giard). Paris. 187-219.

De Broglie, Maurice; Thibaud, Jean. 1925. Sur l'absorption exceptionnellement intense d'une radiation par l'atome qui vient de l'émettre. *C. R. Hebd. Séances Acad. Sci.* 180: 179-180.

Brown, Andrew Philip. 1997. *The Neutron and the Bomb. A biography of Sir James Chadwick*. Oxford: University Press.

Brush, Stephen George, Everitt, C. W. Francis. 1969. Maxwell, Osborne Reynolds, and the radiometer. *HSPS.* 1: 105-125.

Brush, Stephen George. 1976. *The kind of Motion We Call Heat*. Amsterdam-New York-Oxford: North-Holland, 2nd part.

Buchner, Hans. 16 June 1892. Ueber der Einfluss der Lichtes auf Bakterien. *Centralblatt für Bakteriologie und Parasitenkunde* (edited in Kassel (Cassel) by O. Uhlworm, printed in Jena: Gustav Fischer), 11/25: 781-783 especially p. 782; 18 August 1892. *Second Part (II Mittheilung)* 12/7-8: 217-219.

- Buchner, Hans. 1893. Ueber den Einfluss des Lichtes auf Bakterien und über die Selbstreinigung der Flüsse. *Archiv für Hygiene und Bakteriologie* (München: R. Oldenbourg). 17: 179–204.
- Buckley, Oliver Ellsworth. 1916. An ionization manometer. *Proc. Nat. Acad. Sci.* 2: 683-685.
- Bučić, Vesna. 1990. Ljubljanski urarji v 19. in začetku 20. stoletja. *Kronika* (Ljubljana), 38/3: 116–127.
- Bufon, Zmago (Zmagoslav). 1964. Biologija. *Slovenska Matica 1864-1964* (ed. France Bernik). Ljubljana: Slovenska Matica. 334-379.
- Bufon, Zmago. 1967. Janez Anton Scopoli (keyword). In: *SBL*. 10: 256.
- Bufon, Zmago. 1971. Naravoslovje v slovenskem narodnem prebujanju. *Zbornik za zgodovino naravoslovja in tehnike (Anthology)* (Ljubljana) 1: pp. 15–70.
- Bunshah, Rointan F. 1994. History and Current Status of Vacuum Metallurgy. *J. Vac. Sci. Technol. A*. 12/4: 936-945.
- Burić, Anton. 1979. *Povijesna antroponimija Gorskog kotara u Hrvatskoj. Goranska prezimena kroz povijest*. Rijeka: Društvo za zaštitu prirodnokulturne in povijesne baštine Gorskog Kotara. Bettered edition: 1983. Rijeka: Društvo za zaštitu prirodne kulturne in povijesne baštine Gorskog Kotara.
- Buridan, Jean. 1509. *Acutissimi philosophi reuerendi magistri Iohanis Buridani subtilissime Questiones super octo phisicorum libros Aristotelis*. Paris: Dionis Roce.
- Burlaeus, Gualterius (Walter Burley). 1491. *Burleus super octo libros physicorum*. Venetiis: Boneti Locatelli Bergomensis & Octaviani Scoti. Reprint: 1609. *Gualterii Burlaei super Aristotelis libros de physica auscultatione lucidissima commentaria. Cum nova veterique interpretatione. Una cum repertorio tractatum, capitum, dubiorum, conclusionum ac rerum omnium notatu digniorum facillimo ordine digesto. Omnia integerrime, quam antea impressis, recondita, non pauca superaddita, ac exactissima qua fieri potuit diligentia an omni errorum labe vindicator*. Venezia: Pietro Farri (FSLJ-21 a 19, NUK has just Burlaeus' *Super decem libros Ethicos Aristotelis cum duplici textus antiquus. vz. et ejus qui est Argyropoli* of 1521).
- Busch, Hans. 1926. Berechnung der Bahn von Katodenstrahlen im Axialsymmetrischen elektromagnetischen Felde. *Ann. Phys.* 81: 974-993.
- Busch, Hans. 1927. Über Wirkungsweise der Konzentrierungsspule bei der Braunschen Röhre (About the mode of operation of the concentration coil in Braun's Cathode Ray Tube). *Arch. f. Elektrotechn.* 18: 583-594.
- Büttner, Ulrich; Egon Schwär. 2014. Barbara von Cilli - Empress, Femme Fatale, and Vampire, in: *Konstanzer Konzilgeschichte* (ed. Ulrich Büttner, Egon Schwär), Constance: Stadler.
- Cabeo, Nicolaus. 1629. *Philosophia magnetica: in qua magnetis natura penitus explicatur, et omnium quae hoc lapide cernuntur, causae propriae offeruntur: noua etiam praxis construatur, quae propriam poli elevationem, cum suo meridiano, vbique demonstrat,; multa quoque dicuntur de electricis, & alijs attractionibus, & eorum causis.: Additis figuris variis, tam Aeneis, quàm ligno incises*. Köln: Johann Kinckius/ Ferrara: Francesco Suzzi (Franciscus Succius) (V).
- Cabeo, Nicolaus. 1646. *In quatuor libros meteorologicorum Aristotelis commentaria, et quaestiones: quatuor tomis compraehensa; quibus non solum meteorologica ... explicantur, sed etiam universa fere experimentalis philosophia exponitur; multa praeterea hactenus vix pertractata accurate examinantur. 3. In quo praeter alia ... disputatur de fulmine tum caelesti tum terreno de bombardis & tormentis alijs, de coloribus, & coloratis apparentijs*. Romae: Corbelletti.
- Callisen, Adolph Carl Peter (ed.). 1834. *Medicinische Schriftsteller-Lexicon*. Copenhagen: Königl. Taubstummen-Institute.
- Campbell, John. September 1998. Ernest Rutherford Scientist Supreme. *Physics Word*. 11/9: 35-40.

Campbell Swinton, Alan Archibald. 1896. Effects of a strong magnetic field on electric discharges in vacuo. *Proc. Roy. Soc. London*. 60: 179.

Campbell Swinton, Alan Archibald. March 11, 1897. Some Experiments with Cathode Rays. *Proc. Roy. Soc. London*. 61: 79-95.

Campbell Swinton, Alan Archibald. 27 April 1899. On the Luminosity of the Rare Earths when heated in Vacuo by means of Cathode Rays. *Proc. Roy. Soc. London*. 65: 114-119.

Campbell Swinton, Alan Archibald. June 18, 1908. Distant Electric Vision. *Nature*, 78/2016: 151.

Campbell Swinton, Alan Archibald. April 9, 1924. The Possibilities of Television. *Wireless Word and Radio Review*. 51-56.

Cancrin (Kankrin), Franz Ludwig von 1788. *Abhandlung von einer feuerfesten, am Brand spahrenden Fruchtdarre, oder Fruchtriede: Mit 2 Kupfertafeln. Kleine technologische Werke*. 1-2. Giessen: Krieger jüngern (Johann Konrad Krieger). Second edition (Zweite Auflage): 1799. Leipzig: Krieger.

Cantor, Moritz Benedict. 1900. *Vorlesungen über Geschichte der Mathematik*. book 2. Leipzig, B.G. Treubner.

Cantor, Moritz Benedict. 1901. *Vorlesungen über Geschichte der Mathematik*. Leipzig: B. G. Treubner. 3rd part.

Cantor, Moritz Benedict; Cajori F. 1908. *Vorlesungen über Geschichte der Mathematik*. Leipzig: B. G. Treubner. book 4.

Caraman, Philip. 1975. *The lost paradise; an account of the Jesuit in Paraguay 1607-1768 (the Jesuit Republic in South America)*. London: Sidgwick Jackson/ New York: Seabury Press. Translation by Adam Perišković & Elisabeth Tot-Rakoncai: 1990. *Misija Paragvaj: izgubljeni raj 1607-1768*. Zagreb: Globus.

Carazza, Bruno, Kragh, Helge. 1990. Augusto Righi's magnetic rays: A failed research program in the early 20th century physics. *HSPS*. 21: 1-28

Cardano, Girolamo; Huldreich Frölich von Plawen (translator). 1627. *Schatz- vnd Kunstkammer (Kunstkammer) der Natur sampt allen natürlichen Dingen, das ist: eine geheimnußreiche, scharpffsinnige Erkundigung der Natur, dero wesen, Eigenschafften, wundersamen Tugenden, Würckungen vnd zufählen da dann sehr viel schöne ding, von dem gantzen vmbkreiß der Welt, der Him[m]len vnd Spheren, der Cometen, Gestirns, Metallen, Gesteinen, Influentz, sampt der Agricultur vnd pflanzung der Bäumen, Menschen und Thieren ; neben einer neuen Kunst vnd form, die säfft auß allerhand Kräuter zu ziehen: wie dann in gleichem von der Wunderart vnd Bewegung des Fewrs in den chymischen vnd dergleichen subtilen Künsten, da man mit distillieren vnd schmelzen vmbgehet ; mit beschreibung vieler Ländern, Völckern vnd Stätten, seltzamer gebräuchen, sitten*. Basileae: Sebastian Hernici Petri (FSLJ-17 b 10, folio, propriety entry date: 1640).

Cardano, Girolamo. 1550. *De subtilitate libri XXI* Bind to: 1557. *De rerum varitate libri XVII*, Basel. German translation: 1591. Basel. (Pokrajinski muzej Kočevje-II/107).

Carey, George R. 5 June 1880. Seeing by electricity. *Sci. Am.* 42/23: 355.

Carli, Gian Rinaldo. 1745. *Della Spedizione degli Argonauti in Colco: libri quattro. In cui vari punti si dilucidano intorno alla navigazione, all'astronomia, alla Cronologia, e alla Geografia degli Antichi*. Venezia: Giambatista Recurti. 16 + 140 pages.

Carli, Gian Rinaldo. 1745. *Dissertazione sulla declinazione dell'ago magnetico*. In quarto (4^o). Not included in his Collected works in 1784–1794 (*Delle opere del signor commendatore Don Gianrinaldo, conte Carli*). Published as: 1746. Intorno alla declinazione e variazione della calamita, o bussola nautica, dal Polo. *Nuovo Dizionario Scientifico e Curioso Sacro-Profano* (ed. Pivati, Giovanni Francesco), Venezia. Volume 3: 77-87. Reprint with added two pages of introduction on 33 pages and a table of pictures: 1747. *Dissertazione del Signor*

Conte Gianrinaldo Carli pubblico professore di scienza nautica, e geografia nell'Università di Padova, *Intorno alla declinazione e variazione della calamita, o bussola nautica, dal Polo*. Venezia: Benedetto Milocco, In quarto (4°).

Carli, Gian Rinaldo. 1745. *Prolusione accademica recitata nell'aprimiento della nuova cattedra in Padua di scienza nautica e d'astronomia*. Manuscript noted by Stancovich, 1829, 397 in Bossi, 1797, 285.

Carli, Carli, Gian Rinaldo. 1762. *Osservazioni sopra l'orologio Francese, ed Italiano, e la misura del tempo* (Remarks on the French and Italian clock and the measure of time), written for the Journal *Il Caffè* but never printed and later lost. Manuscript noted by Stancovich, 1829, 397 and Bossi, 1797, 285.

Carli, Carli, Gian Rinaldo. 1781–1783. *Le lettere Americane. Nuova Edizione corretta ed ampoliata colla Aggiunta della Parte II ora per la prima volta impressa*. Cremona: Lorenzo Manini.

Carli, Carli, Gian Rinaldo. 1784–1794. *Delle opere del signor commendatore Don Gianrinaldo, conte Carli*, volumes 1–19. Milano: Imperial monistero di S. Ambrogio maggiore.

Carli, Gian Rinaldo; Albònico, Aldo. 1988. *Delle lettere americane Gianrinaldo Carli. Selezione, studio introduttivo e note di Aldo Albònico*. Roma: Bolzoni.

Carli, Giovan Girolamo. 1785. *Dissertazione due dell'Ab. Gio. Girolamo Carli Segretario perpetuo della R. Accademia delle Scienze, Arti, e delle Lettere di Mantova: La I. Sull' impresa degli Argonauti, e i posteriori fatti di Giasone, e Medea; la I. Sopra un antico bassorilievo rappresenta la Medea d'Euripide, conservato nell' Museo della detta Accademia*. Mantova: Giuseppe Braglia. 306 pages.

Carnot, Sadi. 1924. *Reflexions sur la puissance motrice du feu*. Paris. Reprint: 1953. Paris: A. Blanchard.

Caro, Francisco (Francesco Caro, Franciscus Carus, Cari). 1667. *Philosophia naturalis. Ad vsum*

studiosae iuventutis. Ill.mo & excell.mo d.d. Siluestro Valerio equiti, & D. Marci proc. ampliss. dicata a Marco Bembo nobili Veneto. Praeside p. d. Francisco Caro C.R. Congr. è Somasca. Reprint 1670. *Philosophia naturalis. Aloysio et Petri Ord min Observantis dictatus a Stella (Mocerrici (Philip Mocenici?), Aloys s. Petrus), praeside Francisco Caro (Francesco Caro, Franciscus Carus, Cari) C.R. Congr. è Somasca*. Venetiis: Leni (FSLJ-13 f 64).

Carrillo y Laso, Alonso. 1624. *De las antiguas minas de España*. Cordoua (Cordoba): Saluador de Cea.

Carro, Jean de; Portenschlag, Joseph von. 1802. *Beobachtungen und Erfahrungen über die Impfung der Kuhpocke*. Wien: Joseph Geistinger. Not published in Italian language as: “(Istruzione) *Intorno la vaccinazione*” which was a two later work of Michele Francesco Buniva.

Cartier, Gallus (Gallo). 1756. *Philosophia eclectica ad mentem et methodum celeberrimorum nostrae aetatis Philosophorum concinnata et in quatuor partes, Logicam nempe, Metaphysicam, Physicam et Ethicam distributa. A Religiosis Monasterii D. Ettonis vulgo Ettenheim Münster dicti. Ord. S. Benedicti in Brisgoja. Curante et dirigente J. Gallo Cartier Brunrutano Rauraco, ejusdem Monasterii Professo. Capitulari et Subpricie, nec non S.S. Thliae. Professore Ac. Praemittitur In gratiam et usum Religiosorum, praesertim Novitorum Tractatus duo Theologici. I. De doctrina christiana seu rudimentis fidei christianae. II. De Religione seu de statu religioso. Accessere itidem Praeter verias notas ad eruditionem comparatas exercitationes philosophicae, ad varia Philosophiae partium capita accommodatae, et Elementa Geometriae una cum Indice copioso, Augustae Vindelic./ Wirceburgi: Sumptibus Ignatii Adami: Francisci Antonii Veith Fratrum (FSLJ-2 i 42; KKKRS; Karl Peer's library now in NUK: GS II 5051).*

Carus, Paul. 1911, Professor Mach and his work, *The Monitor*, 21/1: 21–31.

Casati, Paolo. 1685. *Fabrica et uso del Compasso di Proportione*. Bologna: Gioseffo Longhi.

Casimir, Hendrik Brugt Gerard (anonymous notice). 2000. In *Memoriam*. H.B.G. Casimir (1909-2000), *Europhysics News*, July-August 2000, p. 30.

Le Cat, Claude-Nicolas. 1749. A Memoir on the Lacrymae Batavae (Dutch tears, prince Rupert's drops, brought to Britain in 1660), or Glass-Drops, the Tempering of Steel, and Effervescence, Accounted for by the Same Principle. By Claud. Nic. le Cat, M. D. F. R. S. &c. Translated from the French, by T. S. M. D., *Philosophical Transactions of the Royal Society of London*, volume 46 nos. 491-496 (1 January 1750): 175-188.

Petrus a S. Catharina (Pedro de Santa Catalina, Petrus a Sancta Catharina, Pietro da Santa Caterina, OFM Disc in Madrid); S. Thomas a S. Joseph (Thoma a Sancto Ioseph, Thomas a Sancto Joseph, Tommaso da San Giuseppe, Tomas de San Jose, OFM Disc in Madrid). 1692-1693. *Matriti* (Madrid): Apud Lucam Antonium de Bedmar & Baldivia, Typographum Regnorum Castellae, & Ligio & Antonio González de Reyes. Reprints: 1697. *Cursus philosophicus ad usum studentium totius ordinis minorum. Tomus 1, Complectens universam Dialecticam nempe tam Sumulas, quàm Logicam magnam, iuxta mentem subtilis Doct. Scoti. Tomus 2, Complectens octo Libros Physicorum, ac Tractatum de Coelo, & Mundo. Tomus tertius complectens tam libros de generatione, & corruptione, quàm libros de anima, necnon & metaphysicam. Auctoribus fr. Petro a S. Catharina et fr. Thoma a S. Joseph, eiusdem ordinis strictioris observantiae, provinciae S. Joseph discalceatorum in Hispania sacrae theologiae lectoribus*. 1-3. Venetiis: Paul Balleoni (Paolo Baglioni) (FSLJ-19 e 5-7/7 e 28-30); 1714. Venetiis: Paul Balleoni (FSLJ-16 d 47-49; MINSPT).

Cauchy, Augustin. 2 November 1840. Rapport sur le nouveau système de navigation à vapeur de M. le marquis Achille de Jouffroy. *C.R.* 11: 678. Reprint. 1885. *Oeuvres*. 1/5: 424-431.

Cauchy, Augustin. 12 June 1843. Memoire Sur un nouveau système de chemin de fer, par M. de Jouffroy (valued by commissioners Arago, general Guillaume Piobert and Pierre-Armand Dufrénoy; Cauchy unofficially involved). *C.R.* 16: 1281.

Cauchy, Augustin. 16 November 1846. Cauchy's Rapport sur le système proposé par M. de Jouffroy pour les chemins de fer (valued by commissioners Arago, Piobert, Dufrénoy, Jacques Philippe Marie Binet and member of the Parisian Academy of Sciences in its mechanical section Henri Gambey). *C.R.* 23: 911. Reprints: 18. November 1846 *L'Institut Journal Universel des Sciences et des sociétés savantes en France et à l'étranger*, 14/672: 381; 1897. *Oeuvres*. 1/10: 202-205.

Cauchy, Augustin. 1882-1975. *Oeuvres complètes d'Augustin Cauchy. Publiées sous la direction scientifique de l'Académie des sciences et sous les auspices de M. le Ministre de l'instruction publique*. 1: 1-12; 2: 1-15. 28 volumes altogether. Paris: Gauthier-Villars.

Cavallini, Ivano (presenter and editor). 1992. *Inaugurazione del monumento a Giuseppe Tartini in Pirano. Ristampa anastatica dell'edizione di Trieste 1896*. Trieste - Rovigno: Università popolare di Trieste - Unione Italiana.

Cavallo, Tiberius. 1772, 1777. *A complete treatise on electricity in theory and practise with original experiments*, 1. edition London. Reprint: 1782. The second edition, with considerable additions and alterations. London: C. Dilly (Žiga Zois' book now NUK-8224), 4: London 1795. German translation of Johann Samuel Traugott Gehler: 1783. *Vollständige Abhandlung der theoretischen und praktischen Lehre von der Elektrizität nebst einigen Versuchen. Aus der Englischen übersetzt. 2-te, mit einigen Zusätzen des Übersetzers vernem*. Auflage. Mit vier Kupfertafel. Leipzig: Weidmanns Erben (Zois' book now NUK-GS 8219).

Cavallo, Tiberius. 1781. *A Treatise on the nature and properties of air and permanently elastic fluids, to which is prefixed, An introduction to chymistry. By Tiberius Cavallo, P.R.S. And Member of the R.I.A. at Naples*. London: Printed for the author (Zois' book now NUK-GS II 8454). German translation: 1783. *Abhandlung über die Natur und Eigenschaften der Luft und der übrigen beständig elastischen Materien: nebst einer Einleitung in die Chymie*. Leipzig: Schwickert. Updated English reprint: 1784. *Description of an improved air-pump, and the account of some experiments made with it*.

- Read at the Royal Society, July 3, 1783. Bind to: 1781. *A Treatise on the nature and properties of air and permanently elastic fluids*. London: J. Nichols.
- Cavallo, Tiberius. 1785. *The History and Practice of Aerostation*. London: Printed for the author and sold by C. Dilly, P. Elmsly, and J. Stockdale (Zois' book now NUK-8478).
- Cazenobe, Jean. 1984. Maxwell, précurseur de Hertz? *La Recherche*. 15: 972-986.
- Chalmers, Alexander (ed.). 1816. *The General Biographical Dictionary*. London: Nichols and Son.
- Chandrasekhar, Subrahmanyan. 1960. *Plasma physics. A course given by Subrahmanyan Chandrasekhar at the University of Chicago*. Chicago: University of Chicago Press.
- Chanute, Octave. 1894. *Progress in Flying Machine* (series of 27 articles originally published in *The Railroad and engineering journal* of New York City: M. N. Forney (beginning in October 1891, in 1893 renamed *American Engineer and Railroad Journal* now *The American engineer*)). New York: American Engineer and Railroad Journal, 308 pages. Reprint: 1899. New York: M. N. Forney.
- Chappe, Claude. 1795. *Aechte und genaue Darstellung der neuerfundenen französischen Fernschreibmaschine, genannt: der Telegraph: Wodurch klar erwiesen wird, dass die in Leipzig herausgekommene, und zu Wien und andern Orten nachgedruckte Beschreibung des Telegraphen durchaus falsch und ganz unrichtig sey*. Wien: Doll (FSNM, 23 pages 17 cm; evaluation of Böckmann, Johann Lorenz).
- Cheney Margaret. 1981. *Tesla – Man Out of Time*, New York: Dell Publishing Co. Reprint: 2001. New York: Simon & Schuster.
- Cilenšek, Edvard. 1956. Elektrostatični pospeševalnik. *Obzornik za matematiko in fiziko* (Ljubljana). 5/1: 24-33.
- Cilenšek, Edvard. 1958. *Elektrotehniški vestnik (Electrical Engineering Journal)*. Ljubljana. 2/4: 393-395.
- Ciperle, Jože. 1980. Ljubljanska gimnazija (1773-1808), *Kronika* (Ljubljana) 28: 111-120.
- Ciperle, Jože. 2001. *Podoba velikega učilišča ljubljanskega. Licej v Ljubljani 1800–1848. (The great college in Ljubljana: lyceum in Ljubljana)*. Ljubljana: Slovenska matica.
- Cividini, Ante. 1934-1936. *Gorski Kotar*. Part I with volumes 1–3 to part V with volumes 1–3. Zagreb: Self-publishing. Reprint: 1939. Zagreb: Self-publishing.
- Civrić, Zorica. 2011. *Teslin čudesni svet elektriciteta (Tesla's Wonderful World of Electricity: Belgrade, Perth, Strasburg, Wien, Vancouver, Paris)*. Beograd: Muzej Nikole Tesle.
- Clausius, Rudolph. 1857. Ueber die Art der Bewegung, welche wir Wärme nennen, *Annalen der Physik*, 100: 353–380. English translation: *Phil. Mag.* series 4, 14: 108-127. Reprint: 1864. *Abhandlungen über die mechanische Wärmetheorie*. 1. Braunschweig: Friedrich Vieweg und Sohn.
- Clausius, Rudolph. 1862. Über die Anwendung des Satzes von der Aequivalenz der Verwandlungen auf die innere Arbeit, *Annalen der Physik*: 116: 73-112. Reprint: 1864, 1867. *Abhandlungen über die mechanische Wärmetheorie*. 1-2. Braunschweig: Friedrich Vieweg und Sohn. Translations: 1862. *Phil. Mag.* 24 (4): 81- , 201- ; 1862. *Journal de Mathématiques Pures et Appliquées* (ed. Joseph Liouville) 7 (2): 269- .
- Clendenon, Cindy. 2009. Ancient Greek Hydromyths about the Submarine Transport of Terrestrial Fresh Water through Seabeds Offshore of Karstic Regions. *Acta Carsologica* (Postojna). 38/2-3: 293-302.
- Coates, Ta-Nehisi. 2015. *Between the World and Me*. New York: Spiegel & Grau.
- Cockcroft, John Douglas. 1944. *Shattering the atom. Science lifts the veil*. Cambridge: Longmans Green & Co.
- Codelli, baron Anton von Fahrenfeld. 1930. Ein neues Fernseh-System. *Fernsehen*. 1/3: 107-114.

Codelli, Baron Anton von Fahnenfeld. Letters to Arco signed on 12 January 1908, undated (February-March 1908) and 20 December 1927 (Codelli, AS, p. 14). Translated by Albin Wedam in: 1977. *Dokumenti Slovenskega gledališkega in filmskega muzeja (Documents of the Slovenian Theater and Film Museum)*. Ljubljana. 13/29: 118-121.

Columbus, Bonaventura (Columbi, Columbo, Colombo). 1647. *Epitome dialectica novi cursus philosophici scotstarum qua doctrina aristotelis ... ab admonum R.P. Magistro Bonaventura Columbo ... ad illustrissimum & reverendissimum dominum D.F. Michaellem Mazarinum (Cardinal Michele Mazarin)*. Aquis Sextiis (Aix-en-Provence): Stephan Davi. Bettered reprint: 1669. *Novus (Perfectus) Cursus philosophicus Scotistarum, complectens vniuersam philosophiam, rationalem, naturalem, moralem, & transnaturalem: industrie peractus, ingeniose elaboratus, atque a subtilium Schola apprime exoptatus Auctore R.P. Bonaventura Columbo Nicensi ordinis Minorum Conventualium Sacrae Theologiae Doctore, eiusdemque Professore in celeberrima urbe Aquensi*. Leyden: Laurent Arnaud & Pierre (Peter) Borde (FSLJ-15 a 42).

Compton, Carleton Thomas (alias Carleton, Crustomos, Comptonus S.J.). 1648. *R. P. Thomae Comptoni Carleton Cantabrigiensis Societatis Jesu in Collegio Anglicans Leodiensi S.S. Thliae Professoris Cursus philosophicus uniuersus additis indicibus necessariis Editio tertia ab auctore aucta et a pluribus, quibus scatebat mendis expurgate*. Antverpiae: Henricum & Cornelium Verdussen (NUK-GS 4795). Reprints: 1649. Antverpiae: Jac. Mearsium (van Meurs) (NUK-GS 21401); 1664. *P. Thomae Comptoni Carleton Cantabrigiensis E Societate Iesv Philosophia Vniuersa. Serenissimo Principi, Maximiliano Com. Pal. Rheni, Vtriusq; Bau. Duci S.R.I, Archidapifero Electori Dicata* (prince lector Maximilian I or less probably the Duke of Bavaria-Leuchtenberg Maximilian Philipp Hieronymus of the house of Wittelsbach). *Auctore R. P. Thoma Comptono Carleton Cantabrigrensi Soc. Iesv, In Colleg. Angl. Leod. Sac. Theol. Professore*. Antverpiae: Jacob Meursius (van Meurs) (FSLJ- 8 a 42).

Conant, James Bryant. 1951. *Science and common sense*. New Haven: Yale University Press. Translation: 1958. *Naturwissenschaft in der Welt*, Weinheim/Berlin: Julius Betz.

Configliachi, Pietro. 7 August 1823, *Elenco delle memorie scientifiche e letterarie. Recitate nelle aduananze dell'imperiale regio istituto di scienze, lettere e arti Lombardo-Veneto*. Milano: Istituto lombardo Accademia di scienze e lettere.

Conley, Timothy K.; Brewer-Anderson, Melissa. 1997. Franklin and Ingenhousz: A correspondence of interests (On their 15-year correspondence). *Proceedings of the American Philosophical Society*, 141: 276-296.

Conradi, Johann Michael. 1690. *Der dreyfach geartete Sehe-Strahl in einer kurtzen, doch deutlichen Anweisung zur Optica oder Sehe-Kunst*, Coburg: Johann Fridrih Regelin (FSLJ-18 c 6).

Cook, Harold John. 2007. *Matters of Exchange. Commerce, Medicine, and Science in the Dutch Golden Age*. New Haven & London: Yale University Press.

Copernicus, Nikolaj. 1566. *Nicolai Copernici Torinensis de revolutionibus orbium coelestium, Libri VI In quibus stellarum et fixarum et erraticarum motus, ex veteribus atqu recentibus observationibus, restituit hic autor. Praeterea tabulas expeditas loculentasque addidit, ex quibus eosdem motus ad quoduis tempus mathematicum studiosus facillime calculare poterit. Item de libris revolutionis Nicolai Copernico narratio prima, per M. Georgium Rheticum ad D. Ioan. Schonerum Scripta. Cum Gratia & Privilegio Caes. Maiest. ex officina Henricpetrina, Basileae*. Translation: 1998. *Des révolutions des orbés célestes*. Paris: Diderot.

Cornaeus, Melchior. 1657. *Curriculum philosophiae peripateticae uti noc tempore in scholis decurri solet, multis figures et curiositatibus a mathesi petitis, et ad physin reductis, illustratum Auctore R.P. Michaelle Corneo, Soc. Jesu SS. Theologiae doctore, ejusdemque in Alma Universitate Herbipolensi Professore Ordinario*. Herbipoli (Württemberg): Elia Michaelis Zinck.

Coronini, Rodolfo. 1769. *Fastorum Goritiensium liber X: cum adnotationibus Historico-genealogicis*. Vienna: Kurtzböck. Translations: Coronini, Rodolfo; Pisanelli, Girolamo. 1772. *Fasti Goritiensis*. Gorizia; Coronini, Rodolfo; Stasi, Alessio; Da Ponte, Lorenzo. 2001. *Fasti goriziani*. Istituto per gli incontri culturali mitteleuropei, Mariano del Friuli (Gorizia): Edizioni della Laguna.
Costa, Barbara. 1997. Gian Rinaldi Carli funzionario teresiano. *Acta Histrae (Koper)*, 5: 205–208.

Cournot, Antoine Augustin. 1827. Reprint: 2010. *Œuvres complètes. Ecrits (Écrits) de jeunesse et pièces diverses*. Volume 1, tom 8 (ed. Bernard Bru & Thierry Martin). Paris: J. Vrin.

Cowling, Thomas George. 1957. *Magnetohydrodynamics*. New York/London: Interscience Publishers.

Crawford, Elisabeth; Lewin Sime, Ruth; Walker, Mark. 1997. A Nobel Tale of Postwar Injustice. *Physics Today*, 1 September 1997, 50/9: 26-32.

Crepeau, John C. (ed.). March 2013. *Jožef Stefan: His Scientific Legacy on the 175th Anniversary*. Sharjah (UAE): Bentham Science Publishers.

Crombie, Alistair Cameron. 1970. *Da S. Agostino a Galileo*. Milano: Feltrinelli.

Crookes, William. 1876. On Repulsion Resulting from Radiation. Parts III. & IV. *Phil. Trans.* 166: 325-376. Separate print: 1876. London: E.J. Davey.

Crookes, William. July-December 1876 published on 29 December 1876. Experimental Contributions to the Theory of the Radiometer - Preliminary Notice, *Chemical News*, 34: 275-279. Simultaneous print: 1876. Experimental Contributions to the Theory of the Radiometer - Preliminary Notice. *Proceedings of the Royal Society of London*, 25/171-178: 303-314.

Crookes, William. 1879. *On radiant matter a lecture delivered to the British Association for the Advancement of Science, at Sheffield, Friday, August 22, 1879*. London. Reprint: *Journal of the Franklin Institute* (Philadelphia), 108/5: 305-316. Translation of Heinrich Friedrich Gretschel: 1879. *Strahlende*

Materie oder der vierte Aggregatzustand: Vortrag, gehalten auf der 49. Jahresversammlung der Britischen Association zur Förderung der Wissenschaften in Sheffield am 22. August 1879. Leipzig: Quandt & Händel.

Crookes, William. 1879. *On radiant matter a lecture delivered to the British Association for the Advancement of Science, at Sheffield, Friday, August 22, 1879*. London. Translation: 1880. *Sur la matière radiante: conférence faite a Sheffield, le 22 Aout 1879, devant l'association Britannique pour l'avancement des sciences*. Paris: Gauthier-Villars. Reprints: 1888. *Ann.Chem.Phys.* 19: 195-231. Reprint: 1905. *Sur la matière radiante. Les quantités* (ed. Abraham & Langevin). 113-124.

Crookes, William. 1907. Experiments on the Dark Space in Vacuum Tubes, *Proc. Roy. Soc. London*, 79/528: 98-117.

Crowther, James Arnold. September 15, 1910. On the Scattering of homogeneous β -rays and the number of electrons in the atom. *Proc.Roy.Soc. Series A, Containing Papers of a Mathematical and Physical Character* 84/570: 226-247.

Crummau, Eleonora Maria Rosalia. 1695. Vienna (Wienn): Leopold Voigt. Reprints: 1696. Vienna: Voigt; 1697. *Freywillig=aufgesprungener Granat=Apfel, des christlichen Samaritans achr: Auß christlicher Liebe deß Nächsten eröfflichen, sonders bewährten Mittele und Wunsche = hayylsamen Artzengen, wider unterschicliche Zustand und Abel daß menschlichen Leibs, und Lebens; Welche mit sonderbarem fleiß, und auff das Hagl daß Nächsten allynit nachdemkleher Sorg, auß viler Artzung = Erfahrene. und bericherter Leib = Artzten, oder Medicin - Doctore, lang gepflogener Erfahrenhheit, von der Hertzogin, fürstin Eleonora, Maria, Rosalia, Hertogin zu Crummau, und fürstin zu Erkerbung, (etc.) zusammen getragen, in öffentlichen druck verfertigt, und zu allgemainen Trast, (etc.). aller Welt entdeckt, aller Krancken gemein gemacht, und eroffent*. Grätz (Graz): Widmanstetterischen Erben (Heirs) (NUK-GS 11844; NUK-GS 12454; MINSPT).

- Cruxilia, Joannis S.J. 1662. *Philosophia Quinque partita*. Vienna: widow Susanna Rickesin (NUK-5030; T), folio.
- Csendes, Peter; Opll, Ferdinand. 2001. *Wien: Geschichte einer Stadt*. Wien: Böhlau.
- Cvelbar, France. 2013. Ratzinger in Einstein, vera in znanost. *Šola kot prostor dialoga med vero, znanostjo in umetnostjo* (ed. Globokar, Roman; Česen, Anton). Ljubljana: Zavod sv. Stanislava. 181-185.
- Cverava, Grant Konstantinovič. 1974. Leningrad: Nauka. *Никола Тесла, 1856-1943 (Nikola Tesla 1856-1943)*. Translated by Đapa-Ivetić, Vukosava; prologue by Ivanković, Radmilo; edited by Popović, Vojin; 2006. *Nikola Tesla 1856-1943*. Beograd: Klub Nikole Tesle.
- Cygan, Jerzy. 1961. *Cosmologia Valeriani Magni, O.F.M.CAP. (1586-1661). Collectanea Franciscana*. 31: 609-636.
- Cygan, Jerzy. 1989. *Valerius Magni (1586-1661) "Vita prima", operum recensio et bibliographia*. Romae: Intitutum historicum Capuccinum.
- Czermak, Paul. 1884. Der Werth der Integrale A1 und A2 der Maxwells'chen Gastheorie unter Zugrundelegung eines Kraftgesetzes: K/r^5 . *Wien. Ber.*, 89/2: 723-740.
- Czermak, Paul; Klemenčič, Ignac. 1893. Versuche über die Interferenz electrischer Wellen in der Luft. *Annalen der Physik*, 286/9: 174-188.
- Čadež, Fran. 1908. *The secret of radioactivity (Skrivnost radioaktivnosti)*. Ljubljana: Slovenska šolska matica (Slovenian School queen Bee).
- Čadež, Marjan. 1945. *Impulzna teorija gibanja: pojavi v ozračju kot slika pojavov v vesolju: začasno poročilo*. Ljubljana: Samozaložba, tisk M. Hrovatin (*Pulse theory of movement, which occurs in the atmosphere as a picture of phenomena in the universe: preliminary report*). Ljubljana: Self-publishing, printed by M. Hrovatin). 37 pages.
- Čech, Pavel. 2005. Rodovniški pregled Lipičevih prednikov in potomcev. In: Lipič, Fran Vijem. *Osnovne značilnosti dipsobiostatike*. Ljubljana: ZRC SAZU. 111-149.
- Čepič, Mojca. 1998. Polarni smektiki. *Obz.Mat.Fiz.* 45/1: 14-28.
- Čermelj, Lavo (Lavoslav). 1923. Ljubljana: Tiskovna zadruga. Reprint: 1980. *Materija in energija v sodobni fiziki*. Ljubljana: Slovenska matica.
- Čermelj, Lavo (Lavoslav). 1950. *Josip Stefan: življenje in delo velikega fizika*. Ljubljana: Slovenski knjižni zavod, Tiskarna "Slovenskega poročevalca". Revised reprint: 1976. *Josip Stefan: življenje in delo velikega fizika*. Ljubljana: Mladinska Knjiga (Juvenile book).
- Čermelj, Lavo (Lavoslav). 1953. *Nikola Tesla in razvoj elektrotehnike. Izdano ob desetletnici smrti Nikole Tesle*. Ljubljana: Mladinska Knjiga.
- Čermelj, Lavo (Lavoslav). 1971. Simon Šubic (keyword). *SBL*. 11: 713-715.
- Čermelj, Lavo (Lavoslav). 1980. *Materija in energija (Matter and energy)*. Ljubljana: SM.
- Črnivec, Živka et all (ed.). 1999. *Ljubljanski klasiki 1563-1965*. Ljubljana: Maturanti klasične gimnazije.
- Čurkina, Iskra Vasil'evna. 1981. Jezuit Gabriel Gruber v Rusiji. *Arhivi*. 4: 107-108.
- Dadić, Žarko. 1982. *Povijest egzaktnih znanosti u Hrvata (History of Exact Sciences in Croatia)*. 1-2. Zagreb: Sveučilišna naklada Liber (University Press, Liber).
- Dadić, Žarko. 1994. *Hrvati i egzaktne znanosti u osvitu novovekovlja*. Zagreb: SNL.
- Dadić, Žarko. 2004. Nikola Tesla – Akademijin počasni član. *Zbornik radova posvećenih 60. obljetnici smrti Nikole Tesle 1856.-1943 (Anthology of Works dedicated to Tesla)*. (ed. Dragutin Fleš, Sibe Mardešić). Zagreb: Hrvatska akademija

znanosti i umjetnosti (HAZU), Razred za matematične, fizičke i kemijske znanosti. 11-18.

Dahan, Jacques Rémi (Jacques-Rémi). 2006. Charles Nodier dans les Provinces illyriennes. *Napoleon na Jadranu. Napoléon dans l'Adriatique* (ed. Šumrada, Janez). Koper/Zadar: Annales. 249-280.

Dahl, Per Fridtjof. 1997. *Flash of the Cathode Rays: a History of J J Thomson's Electron*. Bristol and Philadelphia: Institute of Physics Publishing/ Boca Raton, Florida: CRC Press.

Dalham, Florian. 1752, 1753, 1755. *Floriani Dalham clerici regularis a scholis piis et in Academia Sabausieo Liechensteiniana philosoph. Prof. Instructiones Physicae in usum nobilissimorum suorum auditorum adirntae : quibus seu subsidium praemittuntur institutiones mathematicae, nempe arithmetica, geometriam et trigonometriam complectens, tomo 2. Primam physicam partem: de corporibus & elementis, eorumque proprietatibus complectens. Tomo 3. In quo agitur de geographia physica, & de rebus coelestibus*. 1-3. Vienna: J.T. Trattner (NUK-24069).

Daniel, Gabriel, SJ. 1690. *Voyage du monde de Descartes*. Paris: widow of S. Bénard. Translated as: 1694. *Iter per mundum Cartesii: novae difficultates a peripatetico propositae auctori itineris per mundum Cartesii circa cognitionem brutorum. Cum refutatione duplicis defensionis systematis mundi Cartesii*, Amsterdam: Abraham Wolfgang. Reprinted translation promoted by Ignatius Koller (Choler). 1720, 1721. Vienna: Wolfgang Schwendimann (NUK-GS 4638, NUK-GS 4639).

Daniel, Gabriel. 1694. *Entretiens de Cléanthe et d'Eudoxe sur les Lettres au provincial* (against Pascal). Cologne: Pierre Marteau.

Daniļčeva, M.N. (Moskva, Данилычева, М.Н. (Москва)). 1979. David Brewster (1781-1868) (Дэвид Брюстер (1781-1868)). In anthology: *O fizikah III (About physicists, О физиках), Василий Павлович Зубов, Илья Михайлович Франк, Дмитрий Иванович Менделеев и другие* (eds. А. К. Iškhneli (Александр Константинович Ишхнели), Vakhtang Davidovič Parkadze (Вахтанг Давидович Паркадзе) (in 1973 co-editor of second

volume Manana Vakhtangovna Parkadze)), Tbilisi: Mecniereba (Sak'artvelos Mec'nierebat'a Erovnuli Akademia (Tbilisi). Sovet istorikov estestvoznaniâ i tehniki pri prezidiume Akademii nauk gruzinskoj SSR. 31-33.

Danin, Daniel (Daniil) Semenovich. 1983. *Probabilities of the quantum word*. Moscow: Mir.

Darovec, Darko. 2004. L'empresa mercantilistica di Gian Rinaldo Carli: il lanificio di cerè presso Capodistria. *Quaderni guliani di storia*. 2/1: 143-153.

Darrigol, Oliver. 1998. Aux confins de l'électrodynamique maxwellienne: Ions et électrons vers 1897. *RHS*. 51/1: 5-34.

Darwin, Erasmus. 1 January 1788. Frigoric Experiments on the Mechanical Expansion of Air, Explaining the Cause of the Great Degree of Cold on the Summits of High Mountains, the Sudden Condensation of Aerial Vapour, and of the Perpetual Mutability of Atmospheric Heat. By Erasmus Darwin, M. D. F. R. S.; Communicated by the Right Honourable Charles Greville, F. R. S. *Phil.Trans.* 78: 43-52. Translation: Versuchen auf die Erzeugung der Kälte. *Gren's J. Phys.* 1791. 3/1: 73-77.

Daul, Anton. 1900. *Das perpetuum mobile: eine Beschreibung der interessantesten, wenn auch vergeblichen, aber doch immer sinnreichen und belehrenden Versuche, eine Vorrichtung oder Maschine herzustellen, welche sich beständig, ohne äussere Anregung, von selbst in Bewegung erhalten soll*. Wien/Pest/Leipzig: A. Hartleben.

Davy, Humphry. 1813. *Elements of agricultural chemistry: in a course of lectures for the Board of Agriculture*. London: Longman, Hurst, Rees, Orme & Brown. Translations: 1814. *Elemente der Agrikultur-Chemie in einer Reihe von Vorlesungen gehalten vor der Gesellschaft zur Beförderung des Ackerbaues. Aus dem Englischen übersetzt von Heinrich Zwolff, und mit Anmerkungen u. einer Vorrede beyleitet von Albrecht Thär* (Albrecht Daniel Thaer). Berlin: Nicolai (NUK-9535); 1815. *Elementi di chimica agraria: in un corso di lezioni per il Pensionato di agricoltura del signor Humphry Davy; dottor Antonio Targioni Tozzetti ; con*

correzioni fatte dall'Autore stesso posteriormente all'edizione di Londra del 1813. 1-2. Firenze: Guglielmo Piatti (Zois's book now probably in the USA).

Dekleva, Janez. 2000. Povzetki iz mojih spominov na delo v FI SAZU (IJS, NIJS) in mentorja akademika A. Peterlina. *Pripovedi o IJS ob 50-letnici Instituta »Jožef Stefan«* (Osredkar, Milan; Polenec, Natalija (eds.)). 197-205.

DeKosky, Robert K. 1984. William Crookes and the Quest for Absolute Vacuum in the 1870s. *History of Vacuum*. (ed. Madey; Brown). 84-101.

Del Negro, Piero. 1997. Alcune note su Gian Rinaldo Carli tra Padua e Venezia. *Acta Histriae* (Koper), 5/5: 135–156.

Dember, Harry. 11 June 1925. Über eine About the Beeinflussung der lichtelektrischen Elektronemission durch Bestrahlung mit Kathodenstrahlen (About an influence on photoelectric electron emission by irradiation with cathode rays). *Z. Phys.* 33: 529-532.

Derganc, Franc. 1917. Henri Bergson: filozof moderne Francije (Henri Bergson. The philosopher of modern France). *LZ.* 37/1-2: 101-105; 156-161; 323-327; 381-385; 439-444; 496-500; 549-556; 604-609; 660-664.

Detela, Andrej. 1981, *Dimentropni efekt v homogenem magnetnem polju*. Ljubljana: Graduate seminar of FNT (Faculty of Natural History and Technology).

Detela, Andrej. 2002. *Magnetni vozli*. Ljubljana: Littera picta.

Detela, Andrej. 2013. Nikola Tesla: globina ni dovolj, potrebna je jasnina. *Nikola Tesla. Moji izumi*. Ljubljana: Sanje 120–147.

Detela, Andrej. 2014. *Sintropija v polifaznih zibelkah*. Ljubljana: Elaphe.

Dewar, James; Tait, Peter. 1875. Charcoal vacua. *Nature*. 12: 217-218.

Dewar, James. 1888. Phosphorescence and Ozone. *Proc. Roy. Inst.* 12: 557-560. Reprinted in 1927 in *The collected papers*, 1: pp. 317-321.

Dewar, James. 1888. Magnetic Properties of Liquid Oxygen. *Proc. Roy. Inst.* 13: 695-699. Reprinted in 1927 in *The collected papers*, 1: pp. 335-339.

Dewar, James. 1927. *The collected papers of Sir James Dewar* (edited by Lady Dewar (Helen Rose née Banks married Dewar); James Douglas Hamilton Dickson; Hugh Munro Ross; Ernest Charles Scott Dickson). Cambridge, UK: University Press.

Dežman, Karl. 1856. Meteorologische Beobachtung zu Laibach im Jahre 1855. *Jahresheft des Vereines des krainischen Landes-Museums* (Ljubljana), 11-17.

Dežman, Karl. 1856. Meteorologische Beobachtung zu Laibach. *Zweites Jahresheft des Vereines des krainischen Landes-Museums* (Ljubljana), 1-18.

Dežman, Karl. 1858. Bericht über die bei der monatl. Versammlungen der Mittglieder des Museal=Vereines gehaltenen Vorträge in den J. 1856 und 1857 (Report on the session of Museum society on January 2, 1856, Poročilo na seji Muzejskega društva dne 2. 1. 1856). *Zweites Jahresheft des Vereines des krainischen Landes-Museums* (*Landesmuseum*s, Ljubljana), 2: 88-142.

Dežman, Karl. 1862. Bericht über die bei der monatl. Versammlungen der Mittglieder des Museal=Vereines gehaltenen Vorträge in den Jahren 1858 und 1859. *Drittes Jahresheft des Vereines des Krainischen Landes-Museums*, Ljubljana, 3: 219-236.

Dežman, Karl. 1883. Das Klima and Krain, in: Keesbacher, Friedrich, *Krain und seine öffentliche Gesundheit mit besonderer Berücksichtigung des Jahres 1881*, Ljubljana: Kleinmayr & Bamberg.

Dick, Auguste; Kerber, Gabriele. 1993. The dissertations prepared under the supervision of L. Boltzmann. *Proceedings of the International Symposium on Ludwig Boltzmann, Rome 1989* (ed. Battimelli, Giovanni; Iannello, Maria Grazia;

Kresten, Otto). Vienna: Österreichischen Akademie der Wissenschaften. 29-45.

Dickinson, Henry Winram; Vowles, Hugh Pembroke. 1945. *James Watt and the Industrial Revolution*. London/New York: Longmans Green & Co.

DiLaura, David, L. (ed.); Lambert, Johann Heinrich. 2001. *Photometry or on the Measure and Graduations of Light, Colors and Shade/ Translation from the Latin of Photometria sive de mensura et gradibus luminis, colorum et umbrae*, Boulder: The University of Colorado/ New York: Illuminating Engineering Society of North America.

Dillherr, Karl. 1746. *Tractatus Philosophicus de Barometro*, Authore R. P. Laurentio Gobart à Societate Jesu. Graecii: Haeredum Widmanstadii.

Dimic, Viktor. 2000. Obratovanje reaktorja Triga. *Pripovedi o IJS* (ed. Osredkar, Milan; Polenec Natalija). Ljubljana: IJS. 236–240.

Dimitrijević, Milan Sergije. 2005. *Serbian astronomers in science citation index in the twentieth (XX) century*, Beograd: Zadružbina Andrejević.

Ding, Yiwei Y. March 3, 1994. *Syntheses and studies of acetylenic polymers*, Dissertation at Iowa State University under the supervision of Dr. Thomas J. Barton, IA (United States) Ames Laboratory (AMES) Ames; IA Ames Lab (United States); USDOE (The United States Department of Energy).

Dinsdale, Alfred. March 18, 1931. Television by Cathode Ray, The New Farnsworth System. *Wireless Word and Radio Review*. 28: 286-288.

Diogenov, Gennadij Gerasimovich (Диогенов, Геннадий Герасимович). 1960. *История открытия химических элементов (краткие очерки)* (*Istorija otkritija himičeskih elementov (kratke očerki)*, *History of the discovery of chemical elements (short essays)*). Moskva: Ministrstvo prosvěščenija RSFSR (Москва: Учпедгиз).

Dittmann, Frank. 2007. Henrich Goebel - Aufstieg und Fall einer deutschen Legende zum Erscheinen eines neuen Buches über der Erfinder der Glühlampe. *Technische Geschichte* (published by Verein Deutscher Ingenieure). 74/2: 149-159.

Długosz, Jan (Johannes Longinus). 1455–1480. *Annales seu cronicae incliti Regni Poloniae* (Annals or Chronicles of the Famous Kingdom of Poland) in 12 volumes. First published in 2 volumes as: Długosz. 1711–1712. *Historiae Polonicae libri xii* (Polish Histories, in Twelve Books; written 1455–1480). Lipsiæ (Leipzig)/Frankfurt: Ioannis Ludovic Gleditsch & Mauritius Georg Weidmann.

Dobrzensky, Jacobus Joanes Wenceslaus de Nigro Ponte. 1657. *Nova, et amaenior de admirando fontium genio (ex abditas naturae claustris, in orbis lucem emanante) philosophia...* Ferrariae: Alphons & Jo. Battista de Merestis (S). Reprint: 1659.

Dolar, Jaro. 1974. Med koncem in začetkom: (poskus uvoda v zgodovino NUK). In: *Zbornik Narodne in univerzitetne knjižnice (Proceedings of the National and University Library)*. No. 1: pp. 7-16.

Dolar, Jaro. 1993. Knjižnica frančiškanskega samostana v Kamniku (Library of Franciscans in Kamnik). *500 let Frančiškanov v Kamniku (A Century of Franciscans in Kamnik)* ed. Cevc, Emilijan). Kamnik: Kulturni center. 45-48.

Dolenc, Sašo; Dolar, Mladen; Moder, Gregor; Bunta, Aleš; Ličer, Matjaž (eds.). *The Structure of the Void*. Monography as a separate number of *Filozofski vestnik*, 2013, 34/2.

Dolenc, Sašo; Nemevšek, Miha. 2013. The Void of Quantum Reality. *The Structure of the Void* (ed. Mladen Dolar; Gregor Moder; Aleš Bunta; Matjaž Ličer; Sašo Dolenc). *Filozofski vestnik*, 2013, 34/2: 49-60.

Dolinar, France-Martin. 1976. *Das Jesuitenkolleg in Laibach und die Residenz Pleterje 1597–1704*, Dissertatio ad Doctoratum in Facultate Historiae Ecclesiasticae, Pontificia Università gregoriana (PhD). Ljubljana: Faculty of Theology.

Dolar, France-Martin. 2004. *Libraries through Centuries (Knjižnice skozi stoletja)*. Ljubljana: Filozofska fakulteta.

Domin, Josip Franjo (Iosephi Francisci Domin. 1784 *Dissertatio physica de aeris factitii genesi, natura, et utilitatibus (natvra, et vtilitatibvs)*. Iaurini (Győr): Ioseph Streibig. Reprint and translation: 1987. *Fizikalna razprava o postanku, naravi i koristi umjetnog zraka*. Zagreb: JAZU.

Donnini, Alfredo. 2004. *La matematica come fatto culturale: il Medioevo e i francescani*. Santa Maria degli Angeli (Perugia): Porziuncola.

Doppelmayr, Johann Gabriel (Doppelmeier). 1730. *Historische Nachrichten von den Nürnbergischen Mathematicis und Künstlern: welche fast von dreyen Seculis her durch ihre Schrifften und Kunst-Bemühungen die Mathematic und mehreste Künste in Nürnberg vor andern trefflich befördert, und sich um solche sehr wohl verdient gemacht, zu einem guten Exempel, und zur weitem rühmlichen Nachahmung, in zweyen Theilen an das Liecht gestellet : auch mit vielen nützlichen Anmerckungen und verschiedenen Kupffern versehen*, Nürnberg: Peter Conrad Monaths.

Doreguzzius (Doregucci), Natalis (ed.) & signer of dedication; Du Hamel (Duhamel), Jean-Baptiste. 1682. *Philosophia vetus, ed nova ad usum scholae accomodata in Regia Burgundia olim pertractata, et in sex tomos divisa. Tomus V., qui physices partem secundum de corporibus vitae, et sensus expertibus complectitur. Ed. altera multo auctior, et emendatior*. Paris/Bologna: Joseph Long. Second edition dedicated to Rainero Maresco senatore Bononiensi (former Gabriel Gruber's book now NUK-GS 8298; FSLJ-13 f 77-79). Third edition: 1684 Paris (Promotion of the book of the first secretary of Parisian academy Jean-Baptiste Du Hamel (Duhamel, du Hamel, 1624-1706) first issued in 1678).

Dörfer, Günter; Müller, Falk. 2006. 1857 - Julius Plücker, Heinrich Geissler und Beginner Systematischer Gesandtanlandungsforschung in Deutschland. *International Zeitschrift für Geschichte und Ethik der Naturwissenschaften, Technik und Medizin (NTM)*. 14/1: 26-45.

Dörfer, Günter. 2008. W. H. Theodor Meyer (1820? – ?) Erfolglos aber folgenreich – aus dem Leben und Schaffen eines hessischen Gelehrten, *MOHG* 93: 199-214.

Döttler, Remigio Samuel. 1815. *Elementa physicae mathematico-experimentalis*. Viennae et Tergesti: Geistinger.

Draper, John William. 1846. On the Cause of the Circulation of Blood. *Phil. Mag.* 28/186 (3): 178-189.

Dresselhaus, Mildred Spiewak; Kalish, Rafael. 1992. *Ion Implantation in Diamond, Graphite and Related Materials*. Springer-Verlag.

Dubos, René Jules. 1950. *Louis Pasteur Free Lance of Science*. Boston: Little, Brown and Company.

Duhan, Laurentius. 1694. Parisiis: Thiboust et Esclassan (Jolibois). Reprint: 1708. *Philosophus in utramq (=utramque) partem, sive selectae et limatae difficultates in utramq partem cum responsionibus. Ad usum scholae. Circa celebres universae Philosophiae controversias. Authore Laurentio Duhan, Licentiate Theologiae etc.* Parisiis: Nicola Simart (NUK-4763 inherited from Stična library as catalogued at Inventory page 22/83: 109v); Reprints: 1715. *Philosophus in utramque partem: sive, selectae et limatae difficultates in utramque partem, cum responsionibus ad usum Scholae, Circa celebres universae Philosophiae Controversias*. Parisiis: Nicola Simart (KSMA); 1726. *Philosophus in utramque partem: sive selectae et limatae difficultates in utramque partem, cum responsionibus: ad usum scholae; circa celebres universae philosophiae controversias*. Paris (FSLJ-17 d 63).

Dulong, Pierre Louis. 1829. Recherchers sur la chaleur des fluides élastiques. *Ann.Chim.* 41: 113-158.

Dupasquier, Sebastian (Sébastien, Sebastianus du Pasquier). 1692. *Summa Philosophiae scholasticae et scotisticae: studentibus franciscanis in quatuor partes scripta... per Fr. Seb. Dupasquier, Minor. Convent...; tomus III Physica*. Lugduni (Lyon): Sumpt. Antonii Briasson, in vico Mercatorio.

Reprints: 1705. *D.o.m. Summa philosophica scholastica et scotistica in quatuor partes scripta & digesta breviter & clare (clare) per fr. Sebastianum Dupasquier... tomus I logica, tomus II metaphysica, tomus III Physica, Tomus IV De corporibus physicis, & anima.* 1-4. Patavii (Padova): Joan Manfrè (Giovann Manfrè) Seminario [et al.] (FSLJ-16 d 58-59); 1732. *D. O. M. Summa Philosophiae scholasticae et scotisticae in quatuor partes scripta, et digesta breviter et clare. Per Fr. Sebastianum Dupasquier Minor. Convent. Sacrae Theol. Doct. ac. Profess. Emeritum Provinciae D. Bonavent. Exprovincial. primar. et Conventual. Cambriensis Alumnum.* Patavii (Padova): Joan Manfrè (NUK-GS 5183).

Dussaud, François (Franz, Frantz); Jaubert, George-François (presenter). 1897. Le microphonographe Dussaud (système Berthon-Dussaud-Jaubert et ses applications au traitement de la surdité et de la surditité (The Dussaud microphonograph of Berthon-Dussaud-Jaubert system and its applications to the treatment of deafness and deaf-mutism, presented by Jaubert, George-François). *La Nature* (Paris) (2 February 1897) 23rd year, 1st semester, no. 1236: 145-147.

Dussaud, François (Franz, Frantz); Armengaud, Jules Alexis Marie (presenter). 1898. Le téléscope Dussaud, *La Nature* (Paris) (21 May 1898) 24th year, 1st semester, no. 1303: 385-386. Translation: 1898. The Dussaud Téléscope. *Scientific American Supplement*, Vol. 46, n° 1174, page 18798 (July 2, 1898).

Dussaud, François (Franz); d'Arsonval, Jacques-Arsène (presenter). January-June 1898. Sur le transport des variations lumineuses au moyen d'un fil conducteur de l'électricité, presented by d'Arsonval. *Comptes rendus* (Paris: Bachelier). 126: 1132-1133.

Džamanjić, Brno (Zamagna, Zamanja, Bernardo). 1768. *Navis aëria et elegiarum monobiblos.* Rome: Paullus Giunchius.

Engelmayr, Angelo. 1738. *Compendiosa ad scientias via: seu philosophia epitomata: studiosae juventuti, nobiliorum praesertim geniis apprimè accomoda composita & divulgata a Angelo Engelmayr.* Linz: Johan Adam Auinger (FSLJ-10 d 6 (also catalogued as FSLJ-5 d 44 and FSLJ-5 d 23).

Compendiosa ad scientias via seu philosophia epitomata :

Ebert, Johann Jacob (ed.). 1775. *Kurze Unterweisung in den Anfangsgründen der Naturlehre: zum Gebrauch der Schulen / herausgegeben von Johann Jacob Ebert.* Leipzig: Christian Gottlieb Hertel (former owner the Ljubljana based Society for agriculture and useful arts (Družba za kmetijstvo in uporabne umetnosti) noted in Wilde-1486 now catalogued as NUK-GS 0 8165 or NUK-8405). Reprint: 1780. *Untewweisung in den Anfangsgrunden der Naturlehre zum Gebrauch der Schulen.* Leipzig: Christian Gottlieb Hertel.

Ebert, Johan Jacob (anonymous). 1804. *Naturlehre für die Jugend zur Beforderung des Beobachtungs- und Forschungsgeistes in den Geschäften des bürgerlichen Lebens.* Vienna: Micahel Schwarz (Schmidbauer) (FSLJ-20 i 25 (kept on shelf 20 k1 25)).

Ebert, Johan Jacob. 1773. *Nähere Unterweisung in den philosophischen und mathematischen Wissenschaften für die obern Classen der Schulen und Gymnasien.* Frankfurt/Leipzig: Christian Gottlieb Herteln (Erberg's book). Reprint edited by Heinrich Sander: 1776. *Herrn Johann Jacob Ebert, Professor zu Wittenberg, Natürliche Geschichte aus seiner näheren Unterweisung in den philosophischen und mathematischen Wissenschaften.* Carlsruhe: Macklott.

Eckert, Michael; Schubert, Helmut; Torkar, Gisela. 1992. The roots of Solid-State Physics Before Quantum Mechanics. *Out of the Crystal Maze. Chapters from the History of Solid-State Physics* (edited by Lillian Hoddeson; Ernest Braun; Jürgen Teichmann; Spencer Weart and Zuoyue Wang). New York: Oxford University Press, 3-87.

Eddington, Arthur. 1926. *Internal constitution of the stars.* Cambridge: University press. Translated by Pahlen, baron Emanuel A. von der. 1928. *Der innere aufbau der Sterne.* Berlin: Springer.

Edison, Thomas Alva. 1879. The action of heat in vacuo on metals. *Chem. News.* 40: 152-154.

- Edison, Thomas Alva. 1905. Un phénomène de la lampe Edison. *Les quantités* (ed. Abraham & Langevin). 183-184.
- Edison, Thomas Alva. 1991. *The papers of Thomas A. Edison. Volumes 1-2.* (ed. Robert A. Rosenberg et al.). Baltimore: The Johns Hopkins University Press.
- Edison, Thomas Alva. 1994. *The papers of Thomas A. Edison. Volume 3. Menlo Park: the early years, April 1876-December 1877* (ed. Robert A. Rosenberg et al), The Johns Hopkins University Press.
- Ehrenreich, Henry. 1995. Strategic curiosity: semiconductor physics in the 1950s, *Phys.Today* (January 1995) 48/1: 28-34.
- Eibel, Julius. 1865. Ein paar geometrische Lehrsätze. *Erster Jahres-Bericht der selbständigen nieder österr. (öffentlichen) Landes-Unter-Realschule in Stockerau*, Stockerau by Vienna: Franz Kühkopf in Korneuburg. 1: 17-21.
- Eibel, Julius. 1868. XVI. Beitrag zur Mechanischen Theorie der Wärme. *ZMF*. 13: 491-496.
- Einstein, Albert. 1905. Über einen die Erzeugung und Verwandlung des Lichtes betreffenden heuristischen Gesichtspunkt, *Ann.Phys.* 4th series, 17 (322/6): 132-148. Simultaneous reprint with his other papers: 1905. Leipzig: J.A. Barth.
- Einstein, Albert. July 21, 1924. Zur Theorie der Radiometerkräfte. *Z.Phys.* 27: 1-6.
- Einstein, Albert; Balibar, Françoise. 1984. *Galilée, Newton lus par Einstein: Espace et relativité.* Paris: Presses universitaires de France. Translation of Ličer, Matjaž & Likar, Vojislav: 2014. *O posebni in splošni teoriji relativnosti. Einsteinovo branje Galileja in Newtona.* Ljubljana: ZRC SAZU.
- Eleršek, Leonard. 2010. *Homo volans. Rani hrvatski avijatičari: 1554–1927 (with photos of Josip Novak).* Zagreb: Republika Hrvatska, Ministarstvo obrane: Oružane snage RH: Hrvatsko ratno airoplovstvo i protuzračna obrana.
- Ellinger, Heinrich Oscar Günther. 1897–1898. *Naturen og dens Kræfter. Populær Fysik.* Copenhagen: Frem.
- Ellis, Charles Drummond; Rutherford, Ernest. 1922. β -ray spectra and their meaning. *Proceedings of the Royal Society of London. Series A, Containing Papers of a Mathematical and Physical Character*, 101/708 (0401): 1-17. Shortened translation: 1922. Über die Deutung der β -Strahlspektren radioaktiver Substanzen. *Zeitschrift für Physik A Hadrons and Nuclei*. 10/1: 303-307 (Received 11 June 1922, Issued December 1922).
- Elschnig, Anton. 1861. Übersichtliche Darstellung der Wärmeverhältnisse im Thierreiche. *Triester Gymnasialprogramm vom Jahre 1861.* Trieste: Hermannstorfer / Hannover: Tierärztl. Hochsch.
- Elschnig, Anton. 1869. Kurzgefasste Anleitung zu barometrischen Nivellirungen mit Quecksilber- und Metallbarometern, nebst e. Anhang, zahlr. barometrisch u. trigonometrisch bestimmte Höhen von Salzburg enthaltend. *Jahresberichte der k. k. Oberrealschule in Salzburg 3.* Salzburg: Glonner.
- Elze, Theodor. 1877. *Die Universität Tübingen und die Studenten aus Krain, Festschrift zur Vierten Säcularfeier der Eberhard-Karls-Universität.* Tübingen: Franz Fues. Reprint: 1977. München: R. Trofenik.
- Emsmann, August Hugo. 1861. Positive und negative Fluorescenz. Phosphorescenz und Fluorescenz, *Ann.Phys.* 114 (190/12): 651-657.
- Emsmann, August Hugo. 1866. Prioritätsansprüche in Betreff der negativen Fluorescenz oder Calorescenz oder Calcescenz, *Ann.Phys.* 129 (205/10): 352.
- Engdahl, Frederick William. 2012. *Myths, Lies and Oil Wars*, Wiesbaden: Engdahl. Translation: 2014. *Vojne za Nafto.* Mengeš: Ciceron.
- Epp, Franc Xaver. 1772. *Problemata Electrica.* Vienna. Reprint: Epp. 1773. *Problemata Electrica publicae disputatione proposita a P. Franc Xav. Epp S.J. in electorali Lyceo Monacensi Professore Physices p.o. Defentibus Benedicto Knilling,*

Josepho Hall, Joseph Widman. Monaci: Joannis Nep. Friz (Munich: Johann Nepomuck Fritz) Pars I (146 pages) pars I (83 pages) (NUK-8558 as the item previously noted at SI_AS 1052, Žiga Zois, Special Activities (Posebno udejstvovanje) catalog on unbound sheets, fasc. 19, no. 23)

Erast, Thomas; Dudith, András. 1579. *De cometarum significacionibus comentariolus*. Reprint: Erast, Thomas; Dudith, András; Aquarcialupi, Marcello. 1580. *De cometarum significacionibus iudicium Thomae Erasti. De cometiis dissertationis novae clarissimorum virorum*. Basileae: Ex Officina Leonard Osteni sumptibus Peter Perna. Reprint in anthology: Bose, Johann Andreas (ed.). 20 May 1665. *De significatu cometarum dissertationes et iudiciae doctorum hominum (De significatu cometarum dissertationes et iudicia doctorum hominum)*. Panoviae: Guilem Antonio / Jenae: Georg Sengenwald.

Erberg, Anton. 1730, 1731. *Discussio peripatetica, in qua philosophiae Cartesianae principia per singula fere capita, seu articulos dilucide examinantur. Honoribus ... dominorum, dum in ... Universitate Viennensi, promotore Antonio Erber ... laurea insignirentur (etc)*, Vienna: Wolfgang Schwendimann (FSLJ-9 f 32 with a list of new baccalaevrates), 297 pages with 587 articles as abridged promotion of a work of Ioannes Vincentius (Jean Vincent) published in 1677.

Erberg, Anton. 1750, 1751. *Cursus philosophicus methodo scholastica elucubratus per K. S. Antonium Erber e Societate Jesu AA. LL. Philosophiae nci non SS. Theologiae Doctorem in Alma ai Celeberima Universitate Praecensi Cancelarium emeritum. Tractatus I. In universam Logicam. Tractatus II. In Phisicam generalem. Tractatus III. In Phisicam particularem*. Vienna: Joan. Thomae Trattner & Caspar Schmid.

Erberg, Bernhard Ferdinand. 1760. *Notitia illustris regni Bohemiae scriptorum geographica et chorographica*, Vindobonae: Joseph Kurtzböck.

Erberg, Bernhard Ferdinand. 1762. *Caroli Andriani, ... Epochae Habsburgo-Austriacae, Mariae Theresiae Augustae honoribus dicatae a Theodoro L.B. de Pelichy et Turksweert, dum idem sub*

augustissimis auspiciis in regio Theresiano nobilium collegio-tentamen publicum ex jurisprudentia publica universali, gentium er particulari sacri imperii Romano-Germanica subibat Praeside perillustri, ac juris contultissimo viro domino Paulo Josepho Riegger Sac. Caes. Reg. Majest. A Consiliis Aulicis & Canonum Professore P. & O. Societatis Liter. Roboretavae Socio (Lectori Bernardinus Erber S.J. Autoris olim in historicis discipulus = Edidit R.P. Bernardinus Erber.). Viennae Austriae: J. Kurtzböck.

Ettingshausen, Albert. 1895. Über hochgespannte Wechselströme. *Mittheilungen des naturwissenschaftlichen Vereines für Steiermark*. Volume 1894: LI.

Ettingshausen, Andreas Ritter von. 1857. *Die Principien der heutigen Physik bei der freier der Übernahme der ehemaligen Universitätgebäudes von der kaiserlichen Akademie der Wissenschaften am XXIX october MDCCCLVII* Wien: Kaiserl. königl. Hof- und Staatsdruckerei.

Euler, Johan Albert; Frisi, Paolo; Béraud, Laurent (or Bertier, Joseph-Étienne). 1755. *Dissertationes selectae Jo. Alberti Euleri, Paulli Frisii, et Laurentii Beraud, qua ad Imperialium Scientiarum Petropolitanam Academiam an. 1755 missae sunt... Disquisitio de causa physica electricitatis ab Academia Scientiarum Imperali Petropolitana praemio coronata in publico Academiae conventu die vi. Septembr. MDCCLV una cum aliis duabus dissertationibus de eodem argumento [by Paolo Frisi and Laurent Béraud] (De causa electricitatis, De causa electricitatis dissertation. Theoria electricitatis)*. Academia Imperialis Petropolitana. Petropoli/Lucae: Vincent Junctin.

Euler, Leonhard. 1744. *Theoria motuum planetarum et cometarum / Theoria motuum planetarum et cometarum continens methodum facilem ex aliquot observationibus orbitas cum planetarum tum cometarum determinandi: una cum calculo, quo cometæ, qui annis 1680 et 1681, itemque eius, qui nuper est visus, motus verus investigatur*. Berlin. Translation of Johann baron Paccassi Dedicated to Janez Filip Kobencl: 1781. *Beyträge zur Theorie der Cometen; Theorie der Planeten und Cometem von Johann Freyherrn von Pacassi übersetzt, und mit*

einem Anhang und Tafeln vermehrt / Leonh. Eulers, *Director der Königl. Academie der Wissenschaften von Berlin, Mitglied der Kaiserl. Academie der Wissenschaften von Petersburg, ... Theorie der Planeten und Cometen*. Wien: J.T. von Trattner. [4] Bl., 230 p., [1] Bl., III gef. Bl. (leaves) 3 graphs. Darst. (Kupferst.); 4°.

Euler, Leonhard. 14 November 1750. A letter on polyhedral mailed from Berlin to Goldbach in Sankt Petersburg. Published: 1965. *Leonhard Euler und Christian Goldbach, Briefwechsel, 1729-1764*. Berlin: Akademie-Verlag (eds. Adolf Pavlovich Jushkevich (Adolph-Andrei Pavlovič Yushkevich, Адóльф-Андрéй Пáвлович Юшкéвич) & Eduard Winter, translations from Russian language and redactions by P. Hoffmann), Letter no. 149, pp. 332-333.

Euler, Leonhard. 1758. *Elementa doctrinae solidorum. Novi Commentarii Academiae Scient. Imp. Petropolitanae ad annum 1752 et 1753*. 4: 109-140. Reprint: *Opera Omnia* (series 1). 26: 72-93 (Euler Archive - All Works. no 230). <https://scholarlycommons.pacific.edu/euler-works/230> retrieved on 16 August 2020).

Exner, Sigmund. 16 January 1896. *Wien.Klin.Wschr.* 9: 48. Sigmund Exner as head of the Physiology Institute, referred to Roentgen's discovery at the meeting of the Viennese society of physicians (Gesellschaft der Ärzte) on January 17, 1896.

Faber, Philippus (Faventino, Fadentius, Filippo Fabri). 1602. *Philosophia Naturalis Jo. Duns Scoti, ex quatuor libris sententiarum et quodlibetis collecta: In Theoremata distribute...* Venetiis: Io. Baptistam Bertonom (FSLJ-13 c 8, propriety entry: "ad usum Ravenna (Ravenna) toest Vincentius Catinalis/ ad usum Josephi a Labaco 1675 / super novitiatus 1666"). Modified reprint: 1606. *Philosophia natvralis Ioan Dvns Scoti, ex qvatvor libris sententiarvm, et qvodlibetis collecta: in theoremata distributa, & contra aduersarios omnes tam veteres quam recentiores, impugnationibus, & desensionibus illustrata, ac dilucidata*. Venetiis: Io. Baptistam Bertonom (FSLJ-10 i 64).

Fabjančič, Vladislav. 1940. Ljubljanski Frankoviči v 16. in 17. stoletju. *Kronika slovenskih mest*, 7/2:

206–214; Ljubljanski Frankoviči v 16. in 17. stoletju (nadaljevanje), *Kronika slovenskih mest*, 7/3: 142–150; Ljubljanski Frankoviči v 16. in 17. stoletju (konec). *Kronika slovenskih mest*, 7/4: 206-214.

Fabri (Faber), Honoratio. 1668, 1669, 1671. *Physica id est scientia rerum corporearum, in decem tractatus distributa. Auctore Honorato Fabri Soc. Iesu. Cum indice duplici; primo tractatorum, librorum, & propositionum; rerum notabilium, altero... nunc primum in lucem prodit*. Part I, 1669. Lyon: Laurentij Anisson (just volumes 1 and 4 while the volumes 2, 3, and 5 are missing in NUK-8337 with Bookplate: *Collegio Societatis Jesu Donatus Ejusdemqu. Bibliotheca Philosophica Adscriptus Labaci MDCCXVI* (1726)).

Fabri (Faber), Honoratio. 1666. *Honorati Fabri Societatis Jesu Theologi, Tractatus Duo Quorum Prior Est De Plantis, Et De Generatione Animalium; Posterior De Homine*. Parisiis: Francisco Muguët. Reprints: 1677. Second edition, Norimbergae: Endter (FSLJ-10 b 4; Mayr's sales catalogue); 1772. Norimbergae (Nurnberg): Endter.

Fabri (Ruggiero Fabbri), Ruggero, 1855. *Considerazioni del dott. Ruggiero Fabri intorno alle osservazioni del prof. F. Ratti (= Francesco Ratti (1810-1890) sulla polarità elettrostatica. Nuovo Cimento* (giornale di fisica) 2: 250-253.

Fabbri, Ruggiero (Ruggero Fabri). 1857. *Osservazioni microscopiche della scintilla elettrica : comunicazione del socio aggiunto Dottor Ruggero Fabri. Atti dell'Accademia dei (de') Nuovi Lincei*, Sessione I del 6 dicembre 1857 (session on 6 December 1857) 1+3 pages. Reprint: *Il Nuovo Cimento*. December 1858, 7/1: 182–185.

Facciolati, Jacob. 1737. *Jacobi Facciolati Institutiones logicae peripateticae*. Venetiis: Jo. Baptistam Albritium Hier. fil. (heirs and sons).

Faganel, Jože. 1999. *Zoisovi rokopisi (Zois' manuscripts)*. Ljubljana: ZRC SAZU.

Fair, Richard B. January 1998. History of Some Early Developments in Ion-Implantation Technology Leading to Silicon Transistor Manufacturing, *Proc. IEEE* 86/1: 111-124.

Falconer, Isobel. 1988 J. J. Thomson's work on positive rays, 1906-1914. *HSPS*. 18/2: 265-310.

Faninger, Ernest. 1988. *Zoisova zbirka mineralov*. Ljubljana: Zavod SR Slovenije za varstvo naravne in kulturne dediščine.

Faninger, Ernest. 1994/95. Sodelovanje barona Žige Zoisa in Valentina Vodnika na področju geoloških znanosti. *Geologija*. 37-38: 561-564.

Faraday, Michael. December 1847. On the Diamagnetic Conditions of Flame and Gases. *Phil. Mag.* 31 (10) 210: 401-421.

Faraday, Michael. 1857. The Bakerian Lecture: Experimental Relations of Gold (and Other Metals) to Light. *Phil. Trans.* 147: 145-181.

Faraday, Michael. 1950. *Zgodovina Sveče (History of the candle)*. Ljubljana: Mladinska knjiga (Juvenile books).

Faraday, Michael. 1839. *Experimental researches in electricity: series 1 to 14 inclusive: from the Philosophical Transactions for 1831-1838*. London. Published in three volumes: 1839-1855. *Experimental researches in electricity: reprinted from the Philosophical Transactions of 1831-1843, 1846-1852*. Volumes 1-3. London: R. Taylor, J.E. Taylor, W. Francis. Reprint: 1952. *Experimental research in electricity*. Chicago: Encyclopaedia Britannica, Inc.

Fardella, Michel Angelo. 1691. *Universae philosophiae systema in qua nova quadam et extricata Methodo, Naturalis scientiae Scientiae, & Moralis fundamenta explanantur. I. Rationalis, & emendatae Dialecticae specimen tradens: cui accedit Appendix De Triplici Scholarum Sophismate, derecto, & reiecto*. Venezia: Albritius/ Leyden: Peter Valcurt.

Fardella, Michel Angelo. 1691. *Universae usualis mathematicae theoria: additis speciosae et analiticae geometriae, logarithmorum, Trigonometriae planae &a. &a. ad experiment philosophiae facil notitiam assequendam, praecipuis fundamentis. Partes quatuor: In qua nova quadam,*

& extricata Methodo, insigniores Euclidis, Apollonii, Archimedis, & Theodosii Propositiones demonstrantur ... Tomus Primus Qui Doalecticam Mathematicam, seu Organum ad Universalis Quantitatis Naturam aperiendam comparatum, complectitur. Venezia: Albritius.

Fardella, Michel Angelo. 1695. *Utaque dialectica rationalis et mathematica*. Amsterdam: Paolo Antonio Sanzonio.

Fardella, Michel Angelo; Femiano, Salvatore. 1986. *Penseri Scientifici e Lettera antischolastica*. Napoli: Bibliopolis.

Faujas de Saint-Fond, Barthélemy. 1784. *Des Herrn Faujas de Saint-Fond Beschreibung der Versuche mit der Luftkugel, welche sowohl die Herren von Montgolfier, als andere aus Gelegenheit dieser Erfindung in Frankreich gemacht haben : uebersetzt (übersetzt) von Abbé Uebelacker (Franz Übelacker), mit einer Abhandlung derselben, wodurch erwiesen wird, dass (daß) ein deutscher Physiker von XIV (XIII) Jahrhunderte der Urheber dieser Erfindung sey*. Vienna: Josef Edler von Kurzbeck.

Faustmann, Gerlinde. 1994. *Österreichische Mathematiker um 1800 unter besonderer Berücksichtigung ihrer logarithmischen Werke*. Wien: Österreichischer Kunst- und Kulturverlag.

Favaro, Antonio. 1917. I successori di Galileo nello Studio di Padova fino alla caduta della repubblica. *Nuovo archivio veneto*, N.s., a. 17, vol. 33, part 1: pp. 96-182.

Felici, Riccardo. 1852. *Sulla teoria matematica dell'induzione elettro-dinamica: (prima, seconda)*. Memoria di Riccardo Felici. Pisa: Nistri.

Felici, Riccardo. 1862. Esperienze sulla velocità della elettricità, e sulla durata della scintilla, *Nuovo Cimento*, 15/1: 339-365.

Feffer, Stuart Michael. 1989. Arthur Schuster, J. J. Thomson, and the discovery of the electron. *HSPS* 20: 33-61.

Ferrari da Monza, Giuseppe Antonio (Joseph Anton). 1746, 1747. Venetiis: Modeste Fentium

(Fenzio). Reprint: 1754. *Philosophia Peripatetica: Adversus Veteres, Et Recentiores Praesertim Philosophos Firmioribus Propugnata Rationibus Joannis Dunsii Scoti Subtilium Principis / Tomus Primus, Philosophiae Prolegomena, Logicam, Metaphysicam, & Ethicam complectens. Tomus secundus In quo prior Physicae Pars, hoc est Physica Generalis explicatur. Tomus tertius. Secundam, & tertiam physicae partem exponens. Accessit index rerum praecipuarum. Opera Et Studio F. Josephi Antonii Ferrari De Modoetia Ordinis Minorum Sancti Francisci, Conventualium nuncupatorum, Artium, & Sacrae Theologiae Doctoris. 1-3. Venetiis: Thoma Bettinelli (FSLJ- 2 i 10-12; MINSPT; KSSKL has just 3rd volume with propriety entry of Novo Mesto Capuchins: *Loci Capucinorum Rudolphswerti*). Third edition with added responding to Fortunato da Brescia (Brixia) (editio tertia / ab ipso auctore recognita, & nonnullis quaestionibus, atque doctrinis adauct): 1767. *Philosophia peripatetica adversus veteres, et recentiores praesertim philosophos: firmioribus propugnata rationibus Joannis Dunsii Scoti subtilium principis atque speciatim a R.P. Fortunati a Brixia responsis, et objectis distinctius vindicate. Opera et studio F. Josephi Antonii Ferrari de Modoetia Ordinis Minorem S.P. Francisci Conventualium. Venetiis: Thoma Bettinelli.**

Feussner, Wilhelm. 1873. Ueber die von Herrn Sekulić beschriebene Interferenzerscheinung. *Annalen der Physik. Sep.-Abz., 225/8: 561-564.*

Feussner, Wilhelm. 1877. Neuer Beweis der Unrichtigkeit der Emissionstheorie des Lichts. *Annalen der Physik. 236/2: 317-332.*

Feynman, Richard Phillips. 2000. *The Pleasure of Finding Things out*. London: Allen Lane.

Filippov, Aleksandr Tichonovič (Филиппов, Александр Тихонович). 1986. *Mnogolikii soliton (Многоликий солитон)*. Moskva: Nauka. Translation: 2000. *The Versatile soliton*. Boston/Basel/Berlin: Birkhauser. Reprint: 2010. *The Versatile soliton*. Boston: Birkhauser.

Filipović, Ivan; Rajhman, Jože. 1982. Vergerius (Vergerij, Vergerio) Peter Pavel ml. (keyword). *SBL. 4: 407-409.*

Filonovich, Sergeĭ Rostislavovich (Filonovič). 1990. *Sud'ba klassičeskogo zakona: Proshloe i nastoiashchee zakona Kulona (Судьба классического закона)*. Moscow: Nauka.

Finn, Bernard S. 1964. Laplace and the Speed of Sound. *Isis. 55: 7-19.*

Finsen, Niels Ryberg. 1893. *Om Lysets Indvirkninger paa huden* (on the effects of light on the skin), *Hospitalstidende* (Copenhagen). Volume 36 (4/1) / no. 27 (5 July 1893): 721-728.

Finsen, Niels Ryberg. 1896. *Om Anvendelse i Medicinen af koncentrerede (kemiske) Lysstraaler* (*The use of concentrated chemical light rays in medicine*). København (Copenhagen): Gyldendal. Translation: 1899. *Ueber die Anwendung von concentrirten chemischen Lichtstrahlen in der Medicin*. Leipzig: Vogel.

Fioravanti, Leonardo. 1561. *Sopra la chirurgia, con la dichiarazione di molte cose necessarie da sapere, non piu scritte in modo tale ... Sine loco & anno* (a final part of Fioravanti's work *Compendio di tutta la cirugia (Compendio di tutta la cirugia), vtilissimo ad ogni studioso di quella, & sopra modo necessario. Per Pietro et Lodovico Rosetini* (translators Pietro Rositini (Pietro Rostini, Pietro Rostinio, Rossettini from Prat'Albonio (Pralboino by Brescia)) and Lodovico Rositini) *medici, estratto da tutti quelli che di essa n'hanno scritto. Di nuovo ristampato, dall' eccellente m. Leonardo Fieravanti medico et cirugico bolognese ampliato, aggioutoui un nuouo trattato, con bellissimi discorsi adornato ... Et li disegni de gli instrvmenti, a tal' arte piu che necessari*. Venetia: Lodovico Avanzo. Edition of 1607. Venetia: Lucio Spineda or the edition of 1630 kept as NUK-R 23476, 129^f–175^f bind to (adligate) the manuscript entitled: *Virtù del rosmarino* NUK-R 338). Modified Reprints: 1673. *Tesoro della vita humana, dell' ... dottor ... Leonardo Fioravanti ... Diviso in quattro libri: nel primo, si tratta delle qualità, & cause di diuerse infermità, con molti bei discorsi sopra di ciò. Nel secondo, si descriuono molti esperimenti fatti da lui in diuerse parti del mondo. Nel terzo, vi sono diuerse lettere dell'autore, con le sue risposte: doue si discorre così in fisica, com' in cirugia. Nel quarto, & vltimo, sono riuelati i*

secreti più importanti di esso autore. Venetia: Brigna (M. Gerbec's library now SKLJ); 1677. *Compendio di tutta la chirurgia*. Venetia: Geo. B. Brigna (NUK-GS 11821).

Fischer, Johann Carl (Karl). 1801-1808. *Geschichte der Physik seit der Weiderherstellung der Künste und Wissenschaften bis auf neuesten Zeiten*, 1-8. Göttingen: Johann Friedrich Röwer.

Fisher, David E., Fisher, Marshall Jon. 1996. *Tube. The invention of Television*. Washington, DC: Counterpoint. Paperback reprint: 1997. San Diego (California): Harcourt Brace.

Flamm, Dieter (ed.). 1995. *Ludwig Boltzmann Henriette von Aigentler Briefwechsel*. Wien / Köln / Weimar: Böhlau Verlag.

Flehsig, Alexander Jürgen. 2013. *Frühneuzeitlicher Erfindungsschutz: eine Untersuchung unter besonderer Berücksichtigung der Reichsstadt Augsburg*. PhD dissertation at University of Augsburg. Münster: LIT.

Fletcher, Harvey. 1982. My work with Millikan on the oil-drop experiment, *Phys. Today* (June 1982, 198206), 35/6: 43-47.

Fletcher, John. 1986. Kircher and Astronomy: a Postscript (ed. Casciato, Maristella; Ianniello, Maria Grazia; Vitale, Maria), *Enciclopedia in Roma Barocca: Athanasius Kircher e il Museo del Collegio romano tra Wunderkammer e museo scientifico*, Venezia: Marsilio, 129-138.

Fodor, Etienne de (Étienne, István). 1892. *Die elektrische Schweissung und Löthung*. Wien/Pest/Leipzig: A. Hartleben. Book Review of Emil Müller: 1892. *Technische Blätter*, 24: 151.

Fontana, Felice. 1775. *Ricerche fisiche sopra l'aria fissa*. Firenze: G. Cambiagi, 23 pages. Abridged translation: 1775. *Récherches physiques sur l'air fixe*, Jean François Pilâtre de Rozier's *Observations sur la Physique, de chimie, d'histoire naturelle et des arts (Journal de Physique)*, Paris: Ruault. 6/2 (October 1775): 280-289. Also, a separate print in 1775 as an *Extrait du Journal de Physique*, Paris.

Fontana, Felice. 1776. *Recherches physiques sur la nature de l'air nitreux et de l'air déphlogistique*. Paris: Nyon l'aîné & Ph. D. Pierres. German translation by Franz Xaver August Wasserberg: 1777. *Herrn Abts Felix Fontana, S. K. Hoheit des Großherzogs von Toskana Physikers, ... Physische Untersuchungen über die Natur der Salpeterluft; der vom Brennbaren beraubten Luft; und der fixen Luft*. Wien: Gräffer. Reprint: 1787. Wien: Graeffer. Jacques Gibelin's republication of Fontana's notes at the end of Priestley's fifth translated book (Tome 5) entitled: 1780. *Recherches physiques sur la nature de l'air nitreux et de l'air déphlogistique*, par M. l'abbé Felix Fontana. In: *Expériences et observations sur différentes especes d'air, ouvrage traduit de l'anglais de M.J. Priestley ... par M. Gibelin ... Tome cinquieme*. Berlin et se trouve a Paris: chez Saillant & Nyon, 5: p. 139 (Zois acquired all those five Priestley's volumes published in 1775-1780 now catalogued as NUK-GS 0 8443/I-V). German language Viennese-Leipzig translation of Priestley's books by then young Leipzig student physician-botanic Christian Friedrich Ludwig: 1778-1787. *Versuche und Beobachtungen über verschiedenen Gattungen der Luft*. Aus dem Englischen. 6 volumes. Wien / Leipzig: Rudolf Gräffer (NUK-GS 8534).

Fontana, Felice. 1783. *Opuscoli scientifici*. Firenze: Gaetano Cambiagi.

Forster, Aimé. 1867. *Ueber Darstellung künstlicher Leuchtsteine: (Vorgetragen in der bern. naturf. Gesellschaft den 26. Jenner 1867) (About formation of artificial lightstones: (Presented in the Bernese society of naturalists on 26 January 1867)*. Bern: Huber & Comp, Reprint: 1868. *Ueber Darstellung künstlicher Leuchtsteine, Annalen der Physik und Chemie*, 209/1: 94-121; 209/2: 228-258.

Forti, Antonio S.J. 1744. *Philosophia negativa, seu Disputationes philosophicae, in quinque libros divisae, quorum primus summulae, secundus logica, tertius physicae pars prior, quartus physicae pars posterior, quintus metaphysica. Quibus probari contenditur. authore Antonio Forti Societatis Jesu, Calatajeronensi*. In 5 volumes, 3rd and 4th volumes about Physics. Venetiis: Jo. Baptistae Alberti Hieron Filii (Giovanni Battista Albrizzi junior) (FSLJ-1 left, h 1-2 d 86).

Fouché, Rayvon. 2003. *Black Inventors in the Age of Segregation: Granville T. Woods, Lewis H. Latimer, & Shelby J. Davidson*. Baltimore: Johns Hopkins University Press.

Fox, Robert. 1968. Dalton's Caloric Theory. *John Dalton & the Progress of Science* (ed. Donald Stephen Lowell Cardwell). Manchester: University Press. 187-202.

Fox, Robert. 1971. *The Caloric Theory of Gases from Lavoisier to Regnault*. Oxford: Clarendon Press.

Fox, Robert; Guagnini, Anna. 1999. Laboratories, workshops, and sites. Concepts and practice of research in industrial Europe, 1800-1914, *HSPS*. 29: 55-139, 191-294.

Fox Morcillo, Sebastiano (Fox-Morzillo, Foxius Morzillus). 1554. Louvain (Leuven). Reprint: 1560. *Sebastiani Foxii Morzilli Hispalensis De Naturae philosophia, seu de Platonis, & Aristotelis consensione, libri V. Nunc denuò recogniti et à mendis, quibus antea scatebant, sedulo repurgati. De nat. phil. seu de Plat. et Arist. consen. lib. I-V*. Paris: Puteani (Jacques Du Puis), 244 pages, 18 cm (V).

Francoeur, Louis-Benjamin (Francœur). 1800/1801. Paris: H.L. Perronneau. Reprints: 1807. *Traité élémentaire de mécanique, adopté dans l'instruction publique par L.B. Francoeur, professeur aux lycee de Paris. (Traité de Mécanique élémentaire ... rédigé d'après les méthodes de R. Prony ... et destiné à servir d'introduction à sa Mécanique Philosophique)*. Fourth edition. Paris: Bernard, sold at bookstore of J. Klostermann the son in Paris and J. Klostermann the son and father Petersburg (NUK-8511). Reprint of Fourth edition: 1814. St. Petersburg: Pluchart.

Frankfurt, Usher Ionovitch (Oucher, Ушер Ионович Франкфурт); Aleksandr Moiseevitch Frenk (Александр Моисеевич Френк); Ivan Ivanovitch Sokolov (translator from Russian to French language). 1976. *Christiaan Huygens: [1629-1695]*. Moscow: Mir.

Frassen, Claudio. 1668. *Tertia et quarta pars Philosophiae academicae quam ex selectissimis*

Aristotelis et doctoris subtilis Scoti rationibus ac sententiis ... Ordinavit F. ac P. Claudius Frassen, minor peronensis, & sacrae facultatis parisiensis doctor theologus. Secunda editio priori longè foecundior. Paris: Edmund Couterot. Reprints: Frassen, Claudio; da Fonseca, José Maria Ribeiro (editor). 1686. *Philosophiae academicae*. Tolosae: Guillelmo Ludovico Colomer (FSLJ-5 b 50/5 b 53/13 c 28-31 with ex libris of Ludovici a Gallenfels Bibl. Labaci); 1726. *Philosophiae academicae 1 logicam et metaphysicam completens 2 primam et secundam partes physicae impertarium completens 3 tertiam partem physicam completens 4 moralem scientiam completens... recens in lucem edita correctior & enendatior... Josephi Mariae ab Eborae...* Romae: Rocchi Bernabe (FSLJ-13 c 28-31/13 c 29 has just one volume of three with Škerpin's ex libris).

Fredman, Joseph H. 1997. The Career and Writings of Bartholomew Keckermann (d. 1609). *Proceedings of the American Philosophical Society*. 141/3: 395-364.

Freedberg, David. 2002. *The Eye of the Lynx: Galileo, His Friends and the Beginnings of Modern Natural History*. Chicago: University Press.

Freksa, Frederick (Friedrich). 1914. *Der Wiener Kongress : nach Aufzeichnungen von Teilnehmern und Mitarbeitern*. Stuttgart: R. Lutz. Translation: 1919. *A Peace Congress of Intrigue (Vienna 1815) a vivid, intimate account of the Congress of Vienna composed of the personal memoirs of its important participants, compiled by Frederick Freksa; translated with an introduction and notes by Harry Hansen*. New York (/London): The Century Co.

Frenkel, Jakov Ilyich Frenkel (Il'ich, Яков Ильич Френкель). 1917. The surface electric double-layer of solid and liquid bodies. *Phil. Mag.* 33/196: 297-322.

Frenkel, Jakov Ilyich Frenkel (Il'ich, Яков Ильич Френкель). 1926. *Lehrbuch der Elektrodynamik*. Volume 1: *Allgemeine Mechanik der Elektrizität*. Berlin: J. Springer.

Frenkel, Jakov Ilyich (Yakov Il'ich, Яков Ильич Френкель). 1932. *Wave mechanics*. Volume 1: *Elementary theory*. Oxford: Clarendon Press.

Frenkel, Jakov Ilyich (Yakov Il'ich, Яков Ильич Френкель); Dacos, Fernand. 1935. L'entretien des oscillations par la triode. *Bulletin de l'Association des ingénieurs électriciens sortis de l'Institut électrotechnique Montefiore, université de Liège (Belgium)*, no. 2, 81 pages.

Fresnel, Augustin-Jean. 1822. Extrait d'un mémoire sur la double refraction particulière que présente le cristal de roche dans la direction de son axe (Lu à l'Académie des sciences le 26 novembre 1821). *Bull. de la Soc. Philomath.* (December 1822) 191–198. Reprint: 1822. *Annales de Chimie et de Physique*. 20: 337. Extended Reprint: 1825. *Annales de Chimie et de Physique*. 28/1 (Volume 1: Tome 28): 263–279. Separate print: 1825. Paris: Feugueray.

Fresnel, Augustin-Jean. 1824. Éclairage des Phares. *Bull. de la Soc. Philomath. (Bulletin de la Société Philomathique de Paris)* 63–66.

Fresnel, Augustin-Jean. 1824. Considérations théorétique sur la Polarisation de la Lumière. *Bull. de la Soc. Philomath. (Bulletin de la Société Philomathique de Paris)* 147–158.

Fresnel, Augustin-Jean. 1825. Physique. Note sur la répulsion réciproque que des corps des corps échauffés exercent les uns sur les autres à des distances sensible. *Bull. de la Soc. Philomath. (Nouveau Bulletin de la Société Philomathique de Paris)* Paris: Plassan. 84–96.

Fresnel, Augustin-Jean. 1825. Note sur la répulsion que des corps des corps échauffés exercent sur les autres à des distances sensible. *Annales de Chimie et de Physique*. 29/2 (Volume 2: tome 29): 57–62.

Fresnel, Augustin-Jean. 1825. Observation à ajouter à la Note sur la répulsion que des corps des corps échauffés (exercent sur les autres à des distances sensible). *Annales de Chimie et de Physique*. 29/2 (Volume 2: tome 29): 107–108.

Freytag, Friedrich. 1898. *Die Dampfkessel und Motoren auf der Sächsisch-Thüringischen Industrie-*

und Gewerbeausstellung zu Leipzig 1897. Berlin & Heidelberg: Springer.

Friedel, Robert Douglas; Israel, Paul B.; Finn, Bernard S. 1986. *Edison's Electric Light, Biography of an Invention*. New Brunswick, New Jersey: Rutgers University Press.

Friedel, Walter. 1930. Die geschichtliche Entwicklung des Fernsehens. *Fernsehen*. 1: 12–17.

Frisch, Otto Robert. 1972. *The Nature of Matter*. London: Thames and Hudson. Reprint: 1973. New York: Dutton.

Consideratio nouae Stellae, Qvae Mense Novembri, Anno Salvtis M.D.LXXII. In Signo Cassiopeae populis Septentrionalibus longè latéque apparuit.

Frischlin, Nikodem. March or April 1573. *Consideratio de nova stella, quae mense Novembri anno salutis MD LXXII in signo Cassiopeae populus septentrionalibus longe lateque (longè latéque) apparuit: Scripta ad Illvstrissimvm Principem Ac D.D. Fridericum, Comitem V Virtembergensem... a Nicodemo Frischlino*. Tübingen: Gruppenbachius. Pp. 1–26. Bind to: Maestlin, Michael. 1573. *Demonstratio astronomica loci stellae nova, tum respectu centri mundi, tum respectu signiferi & aequinoctialis*. 27–32. Bind to: Frischlin. 25 December 1572. *Letter to prince Friederic von Württemberg*. Reprint of Maestlin's work: 1620. *Tycho Brahe Astronomiae Instauratae*. Prague.

Frischlin, Nikodem. 21 February 1586. *De astronomicae artis, cum doctrina coelesti, et naturali philosophia, congruentia, ex optimis quibusque Graecis Latinisque scriptoribus, theologis, medicis, mathematicis, philosophis & poëtis collecta: libri quinque. Passim insterta est huic operi solida divinationum astrologicarum confutatio, repetita ex optimis quibusq(ue) auctoribus, tam recentibus quam veteribus, quorum nomina post praefationem inuenies*. Francoforti ad Moenum: Joannes Spieß (bookplate (coat of arms) of Karl Peer, now NUK-R 4380). Reprint: 1601. Francoforti: Wolfgang Richter, Joannes Spieß.

Frischlin, Nikodem. 1598. *Orationes insigniores aliquot: in publicis publicarum Germaniae Academiarum consessibus habitae, olimq[ue]*

seorsim excusae : nunc verò in gratiam philomousom, propter causas in praefatione expositas, coniunctim editae / operâ et studio Georgii Pfluegeri (Georg Pfluger). Francoforti ad Strassburg: Bernhard Jobin (bookplates of Henrico Leitgebio Stutgartiano anno 1603 & later Ex libris Robert Saitschick, then Štefan Tausig donate it to NUK-R 580279).

Frisi, Paolo, 1755. *De existentia et motu aetheris seu de theoria electricitatis ignis et lucis dissertatio* (De existentia et motu aetheris, seu De theoria electricitatis ignis et lucis, dissertatio). In: Euler et all. *Dissertationes selectae Jo. Alberti Euleri, Paulli Frisii, et Laurentii Beraud, qua ad Imperialium Scientiarum Petropolitanam Academiam an. 1755 missae sunt... Disquisitio de causa physica electricitatis ab Academia Scientiarum Imperali Petropolitana praemio coronata in publico Academiae conventu die vi. Septembr. MDCCLV una cum aliis duabus dissertationibus de eodem argumento* [by Paolo Frisi and Laurent Béraud] (*De causa electricitatis, De causa electricitatis dissertation. Theoria electricitatis*). Academia Imperialis Petropolitana. Petropoli/Lucae: Vincent Junctin.

Frisi, Paulo (signed as P.). 1765. *Degl'influssi lunari. Il Caffè: o sia, Brevi e varj discorsi già distribuiti in fogli periodici* (Milano/Brescia of Venetian Republic: Pietro Pizzolato) 2: 27-44. Second edition: 1766. *Caffè*, volume (tom) 1/foglio (number) 3/ 26: 361-369.

Frisi, Paulo. 1766. *Saggio sul Galileo* (il più elegante, e solido scrittore che abbia avuto l'Italia). *Il Caffè: o sia, Brevi e varj discorsi già distribuiti in fogli periodici* (Milano/Brescia of Venetian Republic: Pietro Pizzolato), volume (tom) 2/foglio (numbers) 3(3-4): 17-27. Reprint: 2: 291-295.

Frisi, Paulo. 1781. *Dei conduttori elettrici*. In: *Opuscoli filosofici: I. Delle influenze meteorologiche della luna; II. Dei conduttori elettrici: III. Dell'azione dell'olio nell'acqua: IV. Del calore superficiale e centrale della terra: V. Dei fiumi sotterranei* (the second paper printed there) Milano: Giuseppe Galeazzi.

Fritz, Felix. 1940, 1946. *Leuchtfarben, Geschichte, Herstellung, Eigenschaften und Anwendung* (*Leuchtfarben im Luftschutz ein praktischer Ratgeber für den Gebrauch von Leuchtfarben in verdunkelten Räumen, im Straßenverkehr, zur Kennzeichnung von Wegen, Baulichkeiten und zu sonstigen Zwecken im Luftschutz*). Berlin: Gustav Bodenbender.

Fritze, Johann Friedrich. 1790. *Handbuch über die venerischen Krankheiten*. Berlin. Reprint: 1797. Berlin: Rottmann. Translated by Monteggia, Giambattista. 1791. *Compendio sopra le malattie veneree del dottore Gio. Federico Fritze... Tradoto dal tedesco con alcune annotazioni per G.B. Monteggia*. Milano: printed by (Nella Stamperia di) Giuseppe Marelli, sold by (Si vende da) Giuseppe Galeazzi. Reprints: 1792. Pavia: heirs of (gli eredi di) Pietro Galeazzi; Modified title: 1806. *Compendio sulle malattie veneree del dottor Gio. Federico Fritze consigliere intimo del re di Prussia e professore di medicina pratica nel r. collegio medico-chirur. di Berlino. Tradotto dal tedesco per G.B. Monteggia professore di chirurgia nello spedal magg. di Milano*. Milano: Pirotta e Maspero.

Frölich, Erasmus; his student Edmund baron Brabeck. 1755. *Genealogia Sounekiorum comitum Celeiae, et comitum de Heunburg specimina duo conscripta ab Erasmo Froelich, S. J. Mariae Theresiae Augustae dicata: cum sub Augustis ejusdem auspiciis Edmundus Lib. Baro a Brabeck Hildesiensis, et Halbertadensis Canonicus ex Philosophis, historicae & mathematicis disciplines in Collegio Regio Theresiano S. J. publice respundares...* Viennae. Bind to: *Materia tentaminis publici: quod in Collegio regio Theresiano Societatis Jesu ex anni huius scholastici praelectionibus quovis, cui libuerit, periclitante subibit reverendissimus & illustrissimus D. Edmundus L. B. a Brabeck, ... mense Septembri ... MDCCLV*. Viennae (NUK-262; NMLJ-4857/2).

de la Fuente, Gaspar (Caspar Toletanus). 1631. *R.F. Fr. Gasparis de la Fuente In celeberrimo Minoritarum Regularis Observantiae S. Didaci complutensi coenobio s. theologiae lectoris : Questiones dialecticae, & physicae. Ad mentem subtilissimi doctorum Ioannis Duns Scoti*. Lugduni (Lyon): Jacques Prost; André Prost (FSLJ-10 h 29).

Fugger Germadnik, Rolanda. 2010. *Barbara Celjska 1382-1451*. Celje: Zgodovinski arhiv/Pokrajinski muzej.

Fulhame, Elisabeth. 5 November 1794. *An Essay on Combustion with a View to a new Art of Dying and Painting. Wherein the Phlogistic and Antiphlogistic Hypotheses are Proven Erroneous*. London: J. Cooper. Reprint: 1810. Philadelphia: James Humphreys. Translation: 1798. *Versuche über die Wiederherstellung der Metalle durch Wasserstoffgas, Phosphor, Schwefel, Schwefellber, Geschweltes, Wasserstoffgas, Gephosphorte Wasserstoffgas, Kohle, Licht und Sauren*. Aus dem Englischen Übersetzt von A. G. L. Lentin. Gottingen: Dieterich (NUK-8709, Z).

Funtek, Anton (Editor of *LZg* in 1895-1918, unsigned article). 1 February 1896. *Tagesneuigkeiten*. Röntgen und die Chirurgie (Hand surgery by X-rays). *LZg*. 115/26: 197.

Funtek, Anton (Editor of *LZg* in 1895-1918, unsigned article). 3 February 1896. *Tagesneuigkeiten*. Die Röntgen Strahlen (Pernet's experiments with the X-rays at Internationalen klinischen Aertzetages (Ärztetages) on 30 January 1896). *LZg*. 115/27: 206-207.

Funtek, Anton (Editor of *LZg* in 1895-1918, unsigned article). 7 February 1896. *Tagesneuigkeiten*. Die Röntgen'schen Strahlen (X-rays of cannon barrels and bullets). *LZg*. 115/31: 238.

Funtek, Anton (Editor of *LZg* in 1895-1918, unsigned article). 18 February 1896. *Local Tagesneuigkeiten*. Röntgen-Strahlen (British X-rays for surgical procedures). *LZg*. 115/40: 311

Funtek, Anton (Editor of *LZg* in 1895-1918, unsigned article). 2 March 1896. *Local- und provincial-Nachrichten*. Die Verwendung der Röntgen-Strahlen bei Infections Krankheiten (Destruction of bacilli by X-rays). *LZg*. 115/51: 397.

Funtek, Anton (Editor of *LZg* in 1895-1918, unsigned article). 7 March 1896. *Tagesneuigkeiten*.

Die Röntgen'schen Strahlen (Parisian X-rays photo showing inside of the bomb). *LZg*. 115/56: 433.

Funtek, Anton (Editor of *LZg* in 1895-1918, unsigned article). 27 March 1896. *Tagesneuigkeiten*. Röntgen-Strahlen (X-ray image of the needle in the hand of the French Minister's wife Blanche Mojon married Cavaignac). *LZg*. 115/71: 561.

Furlan, Alfonz. 1926. Pisateljji frančiškani hrvaško-kranjske pokrajine Sv. Križa. *Zgodovinski časopis*. 21: 29-57.

Fuse, Mitsuo (フセ ミツオ). 1989. On the Galvanic Batteries in the late Edo Period, Especially on Shozan Sakuma's Batteries. *Kagakusi Kenkyu (Journal of History of Science, Japan)*. 28/171: 143-151.

Gabor, Dennis. May 1948. A New Microscopic Principle. *Nature*. 161/4098: 777-778.

Gabor, Dennis. 1951. Plasma oscillations, *Brit. J. Appl. Phys.* 2/8 (August 1951): 209-218.

Gabor, Dennis. 1972. Holography, 1948-1971. Nobel lecture. *Science*. 177: 299-313.

Galand, Michèle. 1993. *Charles de Lorraine, gouverneur général des Pays-Bas autrichiens (1744-1780)*. Bruxelles: Édition de l'Université.

Galilei, Galileo. 1606. *Le operazioni del Compasso geometrico e militare*. Padova: Marinelli (Crossed-over proprietary entry: Joannes Ad? 1628; Jesuitical propriety entry *Bibliothecae Philosophicae labacensi collegii (Johannis Matthus) Societatis Jesu Catalogo inscriptu anno 1707* now NUK-GS 8354). Bernegger's translation: 1612. *Galilaei de Galilaeis. Patritii Florentini, mathematicum in gymnasio Patavino... De proportionum instrumento a se invento, quod meritò compendium dixeris universae geometria, tractatus ... ex Italica in Latinam linguam nunc primum translatus, rogatu philomathematicorum a Mathia Berneggero ex italica in latinam linguam nunc primùm translatus: adjectis etiam notis illustratus, quibus & artificiosa instrumenti fabrica, & usus ulterior exponitur*. Strasbourg: Carol Kieffer (Auersperg's book).

Galilei, Galileo; Manolesi, Carlo (ed.). 1655-1656. *Opere di Galileo Galilei Linceo nobile fiorentino, già lettore delle matematiche nelle Università di Pisa, e di Padova, di poi straordinario nello Studio di Pisa, primario filosofo, e matematico del serenissimo Gran Duca di Toscana: in questa nuova editione insieme raccolte, e varij trattati dell' istesso autore non più stampati accresciute...* 2 vol. Bologna: H.H. del Dozza (Auersperg's book).
Galilei, Galileo. 1964. *Избранные труды*. Moscow: Nauka.

Gamow, George. 1961. *The Atom and Its Nucleus*, Prentice-Hall, INC.

Ganot, Adolphe. 1851. *Traité élémentaire de physique expérimentale et appliquée, ... par A. Ganot*. Paris: self-publishing. Translation: 1886 (12th edition). *Elementary Treatise on Physics Experimental and Applied for the Use of Colleges and Schools*. New York: William Wood and Co. Publishers.

Gassiot, John Peter. 1862. On the heat which is developed at the poles of a voltaic battery during the passage of luminous discharges in air and in vacuo. *Proceedings of the Royal Society of London*, 11: 329-334. Translation: 1863. Ueber die Wärme-Entwicklung an den Polen einer Volta'schen Batterie während des Durchganges leuchtender Entladungen durch Luft oder ein Vacuum. *Ann. Phys.* 119: 131-137.

Gatti, Friedrich. 1901, 1905. *Geschichte der K. und K. Technischen Militär-Akademie*. Volume 1 (Theil 1): *Geschichte der K. K. Ingenieur- und K. K. Genie-Akademie: 1717-1869*; Volume 2 (Teil 2): *Geschichte des K. K. Bombardier-Corps, der K. K. Artillerie-Hauptschule und der K. K. Artillerie-Akademie: 1786-1869*. 1-2. Vienna: W. Braumüller.

Gaubil, Antoine. 1970. *Correspondance de Pékin 1722--1759, publiée par Renée Simon*. Études de Philologie et histoire. Geneve: Librairie Droz.

Gautruche, Pierre (Peter Gaultier, Galtruchius). 1653. *Institutio totius philosophiae cum introductione ad alias facultates*. 1-4, Cadomi (Caen): Adam & Joan Cavelier. Reprints: 1656. *Philosophiae et mathematicae totius institutio, cum*

assertionibus disputatis, & vario genere problematum. Ad usum studiosae juventutis (first part: *Physica universalis*, second part: *Physica particularis*, third part: *Mathematica*, fourth part: *Metaphysica*). Cadomi (Caen): Adam Cavelier & Joan Cavelier; 1661. Venezia. Reprint of Mathematical part: *Mathematicae totius philosophiae*, Caen 1653. Reprint of all parts: 1656. *Philosophiae et mathematicae totius institutio, cum assertionibus disputatis, & vario genere problematum. Ad usum studiosae juventutis* (First part: *Physica universalis*, second part: *Physica particularis*, third part: *Mathematica*, fourth part: *Metaphysica*). Cadomi (Caen): Adam & Joan Cavelier (kept in library of University of Oxford (England); I-VI with each part with its own title page and separate pagination in 12^o printed in Caen). Reprint of all parts: 1661. Vienna: Johannes Bleau (Auersperg's book (S)). Reprint with mathematical book: 1661. *Philosophiae ac Mathematicae totius institutio: cum assertionibus disputatis, & vario genere problematum: ad usum studiosae juventutis. Mathematica... Authore P. Petro Galtruchio, aureliano (Institutionis philosophiae physica universalis* (First part *Logica et Philosophia moralis*. Second part: *Physica universalis*. Third part: *Physica particularis*. Fourth part: *Mathematica* (arithmetic, elementary and practical geometry, cosmology, chronology, measurements of time, geography, optics, music (pp. 266-291)). Fifth part: *Metaphysica*), Viennae: bibliopolio Johannes Blaeu (Auersperg's book (S); book of baroness Oršić; FSLJ-22 c 29; Georgetown University (DGU); University of Chicago (CGU); New York Public Library Residence Library (NYP); 291 pages); 1665. *Philosophiae ac mathematicae totius... clara, brevis, et accurata institutio, cum introductione ad alias facultates. Ad usum studiosae juventutis. Editio altera emendatior & auctior* (First part: *Logica et moralis*, second part: *Physica universalis*, third part: *Physica particularis*, fourth part: *Metaphysica*, fifth part: *Mathematica*, sixth part: *Idea et summa simulque index universae huius philosophiae per theses digestae, adiecto indice theologico. Parte altera ostenduntur scopuli novorum dogmatum philosopho cuique ac theologo vitandi*), Cadomi (Caen): Jean Cavelier (each of six parts with its own title-page and separate pagination (bind together textbooks of physics and mathematics); Reprint of mathematics alone: 1668. *Mathematica totius clara,*

brevis et accurata institutio, Cambridge: Richard Green; 1683. London/Cambridge.

Gavarret, Jules Louis Denis. 1857-1858. *Traité d'électricité*. Paris: V. Masson. Translated and processed by Rudolf Arendt: 1859, 1860. *Lehrbuch der Elektrizität*. 1-2. Leipzig: Brockhaus.

Geddes, Keith; Bussey, Gordon. 1986. *Television: the first fifty years*. Bradford, West Yorkshire, England: National Museum of Photography, Film and Television.

Geiger, Hans; Marsden, Ernest. 1909. On a Diffuse Reflection of the α -Particles. *Proc. of Roy. Soc.* 82: 495-500.

Geiger, Hans; Marsden, Ernest, 1913. The Laws of Deflection of α -Particles through Large Angles, *Phil. Mag.* (series VI) 25/48: 604-623. Translation in *Wien.Ber.*

Geiger, Hans. 1910. The ionization produced by an alpha particle. Part II. Connection between ionization and absorption, *Proc. Roy. Soc.* (A83) 88: 505-515. Reprint: *Phil. Mag.*

Geiger, Hans; Nuttall, John Mitchell. 1912. XL. The ranges of the α particles from uranium. *Phil. Mag.* 23/135: 439-445.

Geiger, Hans, Marsden, Ernest. 1913. The Laws of Deflection of α -Particles through Large Angles. *Phil. Mag.* VI, 25: 604-623.

Geissler, Heinrich, Plücker, Julius. 1852. Studien über Thermometrie und verwandte Gegenstände (Studies of thermometry and similar). *Ann. Phys.* 162/6: 238-279.

Geissler, Heinrich. 1868. Neue Erfahrungen in Gebiete der elektrischen Lichterscheinungen. *Ann. Phys.* 135: 332-335.

Geissler, Heinrich. 1874. Ueber die Umwandlung des Gewöhnlichen Phosphors in amorphem durch Einwirkung der Elektrizität. *Ann. Phys.* 228/152: 171-173.

Gemma, Frisius. 1539. *Usus annuli astronomici*. In: *Petri Apiani Cosmographia* Antwerp: Aegidius Coppenius and Arnoldus Berckman.

Gemmell-Flischbach, Max baron; Montesole, Camillo Manussi Edler von (eds.). 1880. *Album des kaiserl. königl. Theresianums (1746-1880): Verzeichniss sämmtlicher Angehörigen der k.k. Theresianischen Akademie*, Wien: Moritz Perles.

Gerland, Ernst. 1877. Ueber den Erfinder des Tellers der Luftpumpe. *Annalen der Physik und Chemie.* 3/2: 665-670.

Gerland, Ernst. June 1883. Ueber Otto von Guericke's Leistungen auf dem Gebiete der Elektrizitätslehre. First Part. *Elektrotechn. Zeitschrift.* 249-252.

Gerstner, Franz Joseph knight. 1791. Zweyte Abteilung. Beobachtungen über den Gebrauch des Barometers bei Höhenmessungen. *Der Beobachtungen auf Reisen nach dem Riesengebirge.* 4: 271-309.

Gestrin, Ferdo. 1981. Italijani v slovenskih deželah od 13. do 17. stoletja, *Zgodovinski časopis.* 35/3: 223-241.

Geyss, Wilhelm. 1700. *Lapis offensionis et petra scandali sunt sententiae philosophicae et genuinae Joannis Duns Scoti subtilium omnium principis Ord. Min. Conv. S. Francisci expositae per A.R.P. Guilielmum Geyss, Ord. Min. S. Francisci Conventualium*. Augsburg/Dillingen: Joannem Casparum Bencard (Johan Kaspar Bencard) (FSLJ-12 c 3, propriety entry: Bibl. Franc. Minim. Labaci 1718/ P Francisco Hammer convent Herbipoli).

Elisabeth Gibney; Davide Castelvecchi. 6 October 2016. Physics of 2d Exotic Matter wins Nobel. *Nature* 538: 18.

Gilbert, William. 1991. *De Magnete*. New York: Dover.

Glasser, Otto. 1959. *Wilhelm Conrad Röntgen*. Springer-Verlag.

- Gloede, Wolfgang. 1986. *Vom Lesestein zum Elektronenmikroskop*. Berlin: VEB Verlag Technik.
- Glonar, Joža. 1925. Dolinar Jurij (keyword). *SBL*. 1: 142.
- Glonar, Joža. 1926. Gruber Gabrijel (keyword). *SBL*. 1: 268-269.
- Glonar, Joža. 1937. Iz stare stiške knjižnice. In: *Glasnik Muzejskega Društva za Slovenijo*. 18: 110–131.
- Gobart, Laurent (Laurentius) S.J. 1702-1703. *Tractatus Philosophicus de Barometro*. Amsterdam: Stephan (Etienne) Roger, 12°. Reprints: 1716. *Tractatus de Barometro... universitate Viennensi, promotore R. P. Francisco Schmelzer ... supremâ AA. LS & philosophiae laureâ insignirentur neodictoribus collegis dicatus anno à parta salute 1716*. Promoted by Franz Schmelzer. Vienna: Voigt. 12° (Erberg's library); 1724. Lugduni Batavorum: Apud Janssonos Van der Aa; 1742. *Quaestio philosophica de pondere aeris addenda ad tractatum philosophicum de barometro, P. Laurentii Gobart E Societate Jesu Amstellodami impressum anno 1703 Auctore eodem*. Amsterdam/Leodii: G. Barnabé; 1746/1747. *Tractatus Philosophicus de Barometro. Authore R. P. Laurentio Gobart, è Societate Jesu, Honoribus Illustrissimorum, Perillustrium, Reverendorum, Religiosum, Praenobilium, Nobilium, ac Eriditorum Dominorum, Dominorum cum in Alma, ac Celeberrima Universitate Graecensi suprema AA. LL. et Philosophiae Laurea Insignirentur. Promotorer R. P. Carolo Dillherr, è Societate Jesu AA. LL. & Philosophiae Doctore, ejusdemque Professore Emerito nec non Incultae Facultatis Philosophiae cae P. T. Seniore. A philosophis Condiscipulis Inscriptus Anno Salutis M.DCC.XLVI Mense Julio, die .* Graecii Typis Haeredum Widmanstadii, 12° (NUK-8294 ; Erberg; FSLJ-16237-18 g 120 format 16° noted 11 promotions of baccalaureates).
- Goebel, Gerhart. 1974. Aus der Kinderjahren des Farbfernsehens. *Funkschau*. 2: 853-856.
- Goethe, Johann Wolfgang von. 1810. *Zur Farbenlehre*. 1-2, Tübingen: Johann Friedrich von Cotta.
- Goldstein, Bernard Raphael. 1971. *Al-Bitruji: on the principles of astronomy : an edition of the Arabic and Hebrew versions with translations, analysis, and An Arabic-Hebrew-English glossary, Volume 1: analysis and translation. Volume 2: the Arabic and Hebrew versions*. New Haven/London: Yale University.
- Goldstein, Eugen. 1881. Ueber elektrische Lichterscheinungen in Gasen. *Ann. Phys.* 12: 90–109. Continuation: 1881. Ueber die Entladung der Electricität in verdünnten Gasen. *Ann. Phys.* 12 (volume 248, number 2): 249-279.
- Goldstein, Eugen. 1895. Ueber (Über) die Einwirkung von Kathodenstrahlen auf einige Salze, *Ann.Phys.* 54: 371-380. Similar simultaneous publication: 1895. Über die durch Kathodenstrahlen hervorgerufenen Färbungen einiger Salze. *Berlin.Ber.* 2: 1017-1024.
- Golob, Andreas. 2012. Mladostna leta v Mariboru. Dnevnik zoologa Karla Heiderja 1870–1873 (Juvenile Years in Maribor, diary of Karl Heider). *Zgodovina za vse*. 19/1–2: 82–100.
- Goodman, Grant Kohn. 2000. *Japan and the Dutch 1600-1853*. Richmond: Curzon.
- Gorman, Michael John. 1994. Jesuit Explorations of the Torricellian Space: Carp-Bladders and Sulphurous Fumes. *MEFRIM*. 106/1: 7-32.
- Gottseer, Martin; Krassnigg; Johann Georg. 1690. *Philosophica polemica. Secundum aphorismos Aristotelis Stagiritae cum annotationibus tum philosophicis, tum strategicis ex variis desumptis. In celeberrima Universitate Graecensi publicae disputationi proposita a d. Joanne Georgio Krassnigg Cive Styro Gonovicensi AA. LL. ... philosophiae baccalaureo, & pro suprema ejusdem laurea candidato. Praeside R.P. Martino Gottseer è Soc. Jesu. Disputation of student Janez Jurij Krasnik (Joann Georg Krassnigg). Graz: heirs of (Haeredes) Widmanstad (2 plates, 8 atlases, 187 pages, 24 cm, FSLJ-30 f 79 dedicated to the owner of Kostel manor Franc Josef Lamberg (* 1673) because of its military content; NUK-GS 36552).*

- Grabnar, Boris. 1977. Nenavadni baron na Kodeljevem (An unusual baron at Kodeljevo of Ljubljana). *Dokumenti Slovenskega gledališkega in filmskega muzeja (Documents of the Slovenian Theater and Film Museum)* Ljubljana: SGFM. 13/29: 110-119.
- Graetz, Leo. 1897. Ein electrochemisches Verfahren, um Wechselströme and Gleichströme zu verwandeln. *Ann. Phys.* 62: 323-327.
- Graetz, Leo. 1 October 1902. Ueber eigenthümlische Erscheinungen. *Ann. Phys.* 9: 1100-1110.
- Graf, Ferdinand. 1875. Geschichte des Naturwissenschaftlichen Vereines für Steiermark. In den Mittheilungen veröffentlichte Abhandlungen. *Mitt. nat. Ver. Steier.* 12: I–XVI.
- Grafenauer, Bogo. 1982. Veronika Deseniška (keyword). *SBL.* 4/13: 412-413.
- Grailich, Joseph Wilhelm; Weiss, Edmund. 1858. Über das singen der Flammen (Sitzung 26 March 1858). *Wien. Ber.* 29/9: 271-280 with additional table of seven figures at the end. Separate reprint: Grailich, Joseph Wilhelm. 1858. *Das singen der Flammen: ein Vortrag. Sammlung wissenschaftlicher Vorträge, gehalten während der Monate Februar und März 1858 im grossenständischen Saale zu Wien von Joseph Grailich.* Wien: G. Gerold, 18 pages.
- Grailich, Joseph Wilhelm. 1858. *Krystallographisch-optische Untersuchungen. Gekrönte Preisschrift,* Wien & Olmüz: E. Hölzel.
- Grailich, Joseph Wilhelm. 1859. Vibrationstheorie der Elektrizität von Prof. K. Robida, *Z. öst. Gym.* 9: 425-427.
- Gramatowski, Wiktor; Rebernik, Marjan (ed.). 2001. *Epistolae Kircherianae.* Rome: Institutum historicum S.I.
- Le Grand, Antoine. 1673. *Antonii le Grand Historia naturae, variis experimentis & ratiociniis elucidata. Secundum principia stabilita in institutione philosophiae edita ab eodem authore.* London, J. Martyn. Reprint: 1678. Nurnberg: edited by Johann Zieger & printed by Christophor Gerhard (FSLJ-17 f 11).
- Le Grand, Antoine. 1672. *Antonii Le Grand Institutio Philosophiae Secundum Principia D. Renati Descartes Nova Methodo adornata & explicata, Cumque Indice locupletissimo aucta; In Usus Iuventutis Academicae.* 3rd edition. London: J. Martyn. Reprint: 1679. Nurnberg: Johann Zieger & Andreas Knorz (FSLJ-19 e 51).
- Grant, Edward. 1981. *Much Ado About Nothing. Theories of Space and Vacuum from the Middle Ages to the Scientific Revolution.* Cambridge: University Press.
- Grant, Edward. 2007. *A History of Natural Philosophy from the Ancient World to the Nineteenth Century.* Cambridge: University Press.
- Gravesande, Willelm (Wilhelm) Jakob van. 1720-1721. *Physices elementa Mathematica Experimentis Confirmata, Sive Introductio ad Philosophiam Newtonianam.* Leiden: Langerak. 1-2. Reprints: 1725. *Introductio ad Philosophiam Newtonianam.* Lugd. Batav (Erberg, 4^o); 1742 (third edition); 1748. *Physices elementa mathematica experimentis confirmata; sive Introductio ad Philosophiam Newtonianam.* In III Tom. Compl. Leyden: Joa. Arn. Langerek, Joa. & Herm. Verbeck (NUK-GS 4241). French translation of C. F. Rolland de Virlois: 1744. *Éléments de Physique ou l'Introduction à la Philosophie de Newton.* Paris; 1749. *Philosophiae Newtonianae Institutiones.* Venetia (Zois library); 1760. *Philosophiae Newtonianae institutiones.* Vienna (W-1493 now NUK-4608 with propriety entry: Inscript. Catalogo Bibl. Philos. Coll. Labac. 1769).
- s'Gravesande, Willelm (Wilhelm) Jakob van. 1722. Essai d'une nouvelle théorie sur le choc des corps: fondée sur l'expérience. *Journal littéraire de la Haye.* Volume 12. Separate print on 56 pages: 1722. La Haye: Thomas Johnson.
- s'Gravesande, Willelm (Wilhelm) Jakob van. 1723. *G.J. 's Gravesande Philosophiae Newtonianae institutiones: in usus academicos.* Lugduni Batavorum: P. van der Aa. Reprint: 1749. *G.J.'s Gravesande Philosophiae Newtonianae*

institutiones: in usus academicos. Edito prima italica auctor. 1-2. Venetiis: Remondinus (Zois' book noted as 1749 *Philosophia Newtoniana Interpreta*, Venetia, valued at 0:70).

s'Gravesande, Willelm (Wilhelm) Jakob van. 1727. *G.J.'s Gravesande matheseos universalis elementa. Quibus accedunt specimen commentarii in arithmetica universalem Newtoni ut et de determinanda forma seriei infinitae adsumtae regula nova. Specimen commentarii in arithmetica universalem Newtoni.* Lugduni Batavorum (Leyden): Samuel Luchtman (Erberg-M19, 8^o).

s'Gravesande, Willelm (Wilhelm) Jakob van. 1736. *G. J. 's Gravesande, introductio ad philosophiam; metaphysicam et logicam continens.* Leyden: Johannes Verbeek; Hermanus Verbeek. Reprints: 1737. Venetiis: Pasquali, Giovanni Battista; 1748. *G.J.'s Gravesande, Introductio ad philosophiam, metaphysicam et logicam continens.* 2nd edition. Venetiis: Jo. Baptistae Pasquali.

Grdenić, Drago. 1987. Tumačenje Dominove fizikalne razprave o postanku, naravi i koristi umjetnog zraka. In: Domin's *Fizikalna razprava*, 1987. Zagreb: JAZU. 3-111.

Grdenić, Drago. 2001. *Povijest kemije.* Translation: 2007. *Zgodovina kemije.* Ptujška Gora: In obs medicus.

Grdenić, Drago. 2003. *Alkemija.* Zagreb: Jasenski i Turk.

Grdina, Igor; Štih, Peter. 1999. *Spomini Helene Kottanner. Ženski glas iz srednjega veka (Female Voice from Middle Ages).* Ljubljana: Korenine/Nova revija.

Greene, Joe E. 2014. Tracing the 5000-year recorded history of inorganic thin films from 3000 BC to the early 1900s AD, *Appl. Phys. Rev.* 1, 041302.

Greene, Joe E. 2015. Tracing the 4000-year Recorded History of Organic Thin Films: from Monolayers on Liquids to Multilayers on Solids, *Appl. Phys. Rev.* 2, 011101.

Greene, Joe E. 2017. Review Article: Tracing the recorded history of thin-film sputter deposition: From the 1800s to 2017. *Journal of Vacuum Science & Technology A* 35, 05C204.

Gren, Friedrich Albrecht Carl. 1791. Swedenborgs Vorschlag zu einer hydraulischen Luftpumpe. *Journal der Physik.* 4: 407-410.

Greyl, Zacharias; Greyl's widow Elisabeth. 1720. *Copia Attestati, Welches von Einer Wohl - Löblichen Reichs - Stadt Augsburg, Zachariä Greyl, Bürgern allda, einer neuinventirten geschwinden Feuer - löschenden Maschine halber, ertheilet worden.* Augsburg.

De Groot, Henk Willy Kees. 1998. *Approaches to the Study of Dutch in Eighteenth Century Japan: Shizuki Tadao and Others: a thesis submitted in partial fulfilment of the requirements for the degree of Master of Arts in Japanese in the University of Canterbury.* PhD dissertation. Canterbury: University of Canterbury.

Grove, William Robert. 1845. On the application of Voltaic ignition to lighting mines. *Phil. Mag.* 27: 442-446.

Grove, William Robert. 7 January 1852, 1 April 1852, 24 April 1852. On the electro-chemical polarity of gases. *Trans. Roy. Soc. (London)* 142: 87-101.

Grove, William Robert. 1846. *Correlation of physical forces: being the substance of a course of lectures delivered in the London institution, in the year 1843 by London Institution.* London: C. Skipper and East. 1867. *The correlation of physical forces, followed by a discourse on continuity. Address to the British Association for the Advancement of Science, delivered by the president, W.R. Grove, at Nottingham, August 22, 1866.* London: Longmans, Green. Both Translated at: 1871. *Die Verwandtschaft der Naturkräfte... Deutsche autorisirte Ausgabe nach der fünften Auflage des englischen Originals herausgegeben durch E. von Schaper ... Mit einem Anhang enthaltend die Rede des autors "ueber den ununterbrachanen Zusammenhaug in der Natur" nebst einem verworte*

zur deutschen Uebersetzung von R. Clausius.

Braunschweig: Friedrich Vieweg und Sohn.

Gruber, Tobias. 1781. *Herrn Tobias Grubers, Weltpriesters und k. k. Bau- und*

Navigationsdirektors im Temeswarer Banat, Briefe hydrographischen und physikalischen Inhalts aus Krain an Ignaz Edlen von Born k.k. wirklichen Hofrath. Vienna: Johann Paul Krauss (NUK-6681; NM-919; NM-1305; NM-1287; Cerknica Library).

Gruber, Tobias. 1786. Ueber die Strahlenbrechung und Abprellung auf erwärmten Flächen. *Böhm. Ges.* 2: 298-333, 13 figures on tables 8 and 9. Reprint 1787: *Physikalische Abhandlung über die Stralenbrechung (sic!) und Abprellung auf erwärmten Flächen, von Abbé Tobias Gruber, k.k. Kameral=Baudirektor. (mit einer Kupfertafel).* Dresden: Waltherischen Hofbuchhandlung. Modified reprint 1799: Beobachtungen über die Strahlenbrechung auf erwärmten Flächen. *Ann. Phys.* 3/4: 377-396 with comments of d.H. Noted in: *Magazin für das Neueste aus der Physik und Naturgeschichte (Voigt's Magazin).* 1788. 5/1: 144-153.

Gruber, Tobias. 1788. Versuche über die Ausdünstung des Wassers im leeren Raume des Barometers. *Böhm. Ges.* 4: 139-151.

Gruber, Tobias. 1790. Ueber die Bestandtheile der Atmosphäre in beziehung auf Dichtigkeit und Druck. *Böhm. Ges.* (NUK-160). Reprint: 1790/91. Betrachtungen über die Bestandtheile der Atmosphäre in Beleihung auf Dichtheit und Druck (Considerationes de partibus constitutivis Athmosphaerae relate ad densitatem et pressuram). *Neuere Abhandlungen der k. böhmischen Gesellschaft der Wissenschaften.* Wien und Prag: Degen. 1/2: 187-189-206. Reprint: 1791-1794. Johan Mayer, *Sammlung Physikalischer Aufsätze besonders die Böhmische Naturgeschichte betreffend, von einer Gesellschaft Böhmischer Naturforscher.* Dresden: Walther.

Gruber, Tobias. 1791. Bemerkungen über H. Erasmus Darwins Folgerungen aus Versuchen auf die Erzeugung der Kälte durch die mechanische Ausdehnung der Luft u.s.w. *Journal der Physik* 1 Heft p. 73, *Gren's J. Phys.* 3: 188-196.

Gruber, Tobias. 1794. Apparat, den Luftgehalt verschiedener Flüssigkeiten zu bestimmen (Sammt einer Kupfertafel). *Gren's J. Phys.* 8/2: 163-196. Figures 1-10 at Table III on p. 324 (noted in the Jesuit biographies as: Apparatus Aeris Diversorum Fluidorum Determinandi).

Grünert, J. Wenzel. 1875. Die Principien der mechanischen Wärmetheorie. *Programm des k. k. Deutschen Ober-Gymnasium in Brünn, für das Schull-Jahr 1873.* Brno (Brünn): Rudolf M. Rohrer (Universitäts- und Landesbibliothek), 1-32. Bind to: *Jahres-Bericht im Schuljahre 1872-73.*

Grünert, J. Wenzel. 1875. Ueber das Wesen der Electricität. Eine moderne Anschauung. *Programm des Communal-Real-und Ober-Gymnasium in Brünn.* Brno (Brünn): Selbstverlag des Comm.-Real-und Ober-Gymnasium.

Gspan, Alfonz; Badalić, Josip. 1957. *Inkunabule v Sloveniji.* Ljubljana: Slovenska Akademija Znanosti in Umetnosti.

Gspan-Prašelj, Nada; Sitar, Sandi. 1991. Zupančič, Jakob (1871–1939) (keyword). *Slovenski biografski leksikon: keywords Zdolšek - Žvanut* (ed. Jože Munda et al). Ljubljana: Slovenska akademija znanosti in umetnosti Znanstvenoraziskovalni center SAZU, 4/15: 864.

Guan, Zengjian. 2005. The Historical Evolution of the Theory of Compass in China. *Studies in the History of Natural Sciences (Zi ran ke xue shi yan jiu)* 24/2: 128-143.

Gudden, Bernhard; Pohl, Robert Wichard. 1924. Über elektrische Leitfähigkeit bei Anregung und Lichtemission von Phosphoren, *Zeit. Phys.* 12/1 (192412) 1-8.

Guericke, Otto von. 1672. *Experimenta Nova (in vacantur) Magdeburgica De Vacuo Spatio.* Amsterdam. Translation: 1986. *Neue "Magdeburgische" Versuche über den leeren Raum.* Leipzig: Akademische Verlagsgesellschaft M.B.H.

Guérinois, Jacques-Casimir. 1703. *Clypeus philosophiae thomisticae contra veteres ac novos eius impugnatores, in quo veterum philosophorum*

dogmata adversus Cartesii aliorumque modernorum inventa stabiliuntur. Bordeaux: Veuve G. de la Court & N. de la Court. Reprints: 1710. Venezia: Balleoni, 6 vol. in-12° (2 vol. de logique (logica & complementum), 3 vol. de physique, 1 vol. d'éthique); 1729. *Clypeus philosophiae Thomisticae contra veteres et novos ejus impugnatores.* Venezia: Paul Balleonium (Balleoni, Baglioni), 7 vol. in-12° (FSLJ-3 e 27-33 with Škerpin's printed bookplate pasted flat against the inside of the cover).

Gufl, Veremund, *Philosophia Scholastica Universa Suis Principis Firmate Et Adversus Neotericos Praecipue Adornate: Tom. I. Dissertatio pracliminaris... Logica... Elementa Arithmeticae, Geometriae et Trigonometriae, cum Indice generalis et 8. Tabulis. Tom. II. Methaphisica cum animadoervinibus in Ontologiam et Connologiam Wolfianam. Tom. III. Physica universalis. Elementa Geo.-et Hydrostatices cum 3. Tabulis. Tom. IV. Physica particularis. Elementa Opticae, Dioptricae.... Tom. I. Monachii et Pedeponti (Stadt am Hof pri Regensburgu): Joannis Gastl, 1753 (FSLJ-5 h 28-31).*

Gunz, Simon. 1792. *Praktische Bemerkungen und Vorschläge zur Verbesserung des Lehrfachs für angehende Haus- und Schullehrer, vorzüglich jene der jüdischen Jugend, nebst einen Gespräche über di Numeration, als ein Beispiel der sokratischen Lehrart,* Prag.

Gunz, Simon. 1792. *Handbuch für Kaufleute.* Prag.

Gunz, Simon. 1793. *Verhältnisstabellen des niederösterreichischen Gewichts, nassen und trockenen Masses, der Elle, Klafter, gegen das altböhmische und umgekehrt.* Prag.

Gunz, Simon. 1802. *Theoretisch-praktisches Rechenbuch für Lehrende und Lernende.* Prague: Scholl; 1810. Fourth bettered edition. Prag: Haase; 1816. *Theoretisch-praktisches Rechenbuch für Lehrende und Lernende.* Prag: Sommerschen (FSNM). Sixth edition: 1832. Prag: Enders,.

Gunz, Simon; Johan Christian Nelkenbrecher. 1809. Prag: Gottl. Haase. Reprints: 1815, Prag: Sommer; 1821. *Nelckenbrechers Taschenbuch der neuesten Münz-, Maaß- und Gewichtsverfassung aller Länder*

und Oerter, ihrer Wechselarten, Usi, Respecttage, öffentlichen Banken, Messen und andrer zur Handlung gehörigen Anstalten und Gegenstände: zum bequemen Gebrauche und zur schnellern Uebersicht für die österreichischen Staaten, nach Wiener, oder niederöp. Münz, Maaß und Gewicht. Prag: Sommer.

Gunz, Simon. 1818. *Rechen-Schlüssel oder äußerst kurze allgemeine Rechenregeln: vermitteltst deren der Locobetrag (in fl. Conv.) eines Wiener Centners oder Pfundes eines jeden vorkommenden Waarenartikels, in einem Amsterdamer, Hamburger, Londoner und französischen Preiskurante... zu berechnen sey.* Prag: Sommer.

Gunz, Simon. 1826. *Anfangsgründe der Gleichungslehre oder der sogenannten Algebra und der hierzu erforderlichen Rechnungsarten mit Buchstaben, insgemein die Buchstabenrechnung genannt: für Lehrende und Lernende.* Prag: Kronberger et Weber.

Gunz, Leopold (Samuel). 1815. *Elementar-Theorie der parallelen Geraden nebst einer Nachricht von der Legendre'schen und einer Beurtheilung der Schulz'shen & Bertrand'schen Theorie der Parallelen.* Graz: Miller (Zois' book later rebind for NUK-4156).

Gurikov, Vladimir Aleksandrovich (Aleksandrovič, Владимир Александрович Гуриков). 1983. *Stanovlenie prikladnoj optiki XV-XX vv (Становление прикладной оптики XV-XIX вв).* Moscow: Nauka.

Gurikov, Vladimir Aleksandrovich. 1985. *Ernst Abbe (Эрнст Аббе (1840-1905)).* Moscow: Nauka.

Güssmann, Franz. 1788. *Nachricht von der Vorrichtung bey Fernröhren, zur Bewirkung ungemeiner Vergrößerungen.* Wien: Joseph Stahel.

Habe, France, Kranjc, Andrej, Delež Slovencev v speleologiji, *Anthology za zgodovino naravoslovja in tehnike,* 1981, 5–6: 13–93.

Hablanian, Marsbed H. 1984. Comments on the history of vacuum pumps. *History of Vacuum.* (ed. Madey; Brown). 17-23.

Hacquet, Balthazar. 1777. Beschreibung und Abbildung einer zweifelhaften Pflanze, welche man gemeingleich zu den Harftermossen (Byssus Botanicorum) rechnet. Von Hacquet, Prof. zu Laibach. *Beschäftigung der berlinischen Gesellschaft naturforschender Freunde*. 3/1: 241-252.

Hacquet, Balthazar. 1778. *Oryctographia Carniolica, oder Physikalische Erdbeschreibung des Herzogthums Krain, Istrien, und zum Theil der benachbarten Länder*. Leipzig: Johann Gottlob Immanuel Breitkopf. 1st part.

Hacquet, Balthazar. 1790. Über eine besondere Bildung des Eises von Jahr 1789. Aus einem Schreiben des Herr Prof. Hacquet an dem Herausgeber. *Magazin für das Neueste aus der Physik und Naturgeschichte*. 13te Büch, 7ten Bandes, 1tes Stück: 20-28.

Hammerschmied, Johann. 1863. *Rundschau im gesamtgebiete der naturwissenschaften und ihre neuesten fortschritte*. Wien: Franz Rospini. 291 pages.

Hammerschmied, Johann. 1871. Ueber den Aether und dessen Beziehungen zur ponderablen Materie, sowie über die davon abhängigen Erscheinungen. Vortrag, gehalten am 5. April 1871. *Schriften des Vereines zur Verbreitung Naturwissenschaftlicher Kenntnisse*. Wien: Verein zur Verbreitung Naturwissenschaftlicher Kenntnisse, printed by C. Gerold's son. 11. Band, 11. Cyclus, Jahrgang 1870/1: pp. 405-474.

Hammerschmied, Johann. 1872. *Die Physik auf Grundlage ener rationellen Molekular- und Aethertheorie zur Erklärung sämmtlicher Naturerscheinungen*, Wien: Gerold's son. 111 pages. Extremely critically reviewed by dr. Ernst Theodor Kötteritzsch from Freiberg: 1873. *Z.Math.Phys.Lit.* 18: 54-58.

Hammerschmied, Johann. 1873. Das Ozon von chemischen, physiologischen und sanitären Standpunkte with epilogues (Schlussworte) A. Ueber den Entstehungszustand der Elemente und den elektrischen Strom. B. Ueber freie Atome und über

die Constitution der Materie Read in front of *Vereins zur Verbreitung Naturwissenschaftlicher Kenntnisse* on 9 April 1873 (Vortrag, gehalten am 9. April 1873). *Schriften des Vereines zur Verbreitung Naturwissenschaftlicher Kenntnisse*. Wien: Verein zur Verbreitung Naturwissenschaftlicher Kenntnisse under presidency of Adam baron Burg, printed by C. Gerold's son, edited by Georg knight Frauenfeld. 11. Band, 11. Cyclus, Jahrgang 1870/1: pp. 393-525. Extended reprint: 1873. *Das Ozon und seine Wichtigkeit im Haushalte der Natur und des menschlichen Körpers. Mit einem Anhang über allgemeine, chemisch-physikalische Fragen*. Wien: Verein zur Verbreitung Naturwissenschaftlicher Kenntnisse, Wien: C. Gerold's son. 164 pages.

Harvey, Edmund Newton. 1957. *A history of luminescence. From the Earliest Times Until 1900*. Philadelphia: The American Philosophical Society.

Hassenfratz, Jean-Henri. January 1785. Lettre de M. Hassenfratz, correspondant de la Académie Royale de Médecine, Minérallogiste, voyageant en Allemagne par ordre du Gouvernement, á M. Mongez le jeune, auteur de *Journal de physique*, sur la cristallisation de la glace. Ebensée ou Lambad (in Upper Austria 90 km south of Linz) dans les mines de sel de la Haute-Autriche on 17 October 1784, Glace cristallisée, observée à Vienne sur le Danube pictured & Seconde Lettre sur la même Object, Kempten (in Swabia) on 25 November 1784. *Journal de Physique, de chimie, d'histoire naturelle et des arts (Observations sur la Physique, sur l'histoire naturel et sur les arts, avec des blanches en taille douce dédiées a Mgr le Comte d'Artois; Par M. L'Abbé Rozier, de plusieurs Académies, & par M. J. A. Mongez le Jeune, Chanon Régulier de Sainte-Genevieve, des Académies Royales des Sciences de Rouen, de Dion, de Lyon, &c, &c.* (ed. François Rozier; Jean-André Mongez (later also by Jean-Claude de La Métherie & Henri-Marie Ducrotay de Blainville). Paris: Au Bureau du Journal de physique, rue & Hôtel de Serpente / Paris: Bachelier. Tome 26 (January): 33-38. Reprint: 1789. Ueber des Krystallisation (= Über des Kristallisation) des Schnees und Eises. Letter to Jean-André Mongez of Rouen Academy. *Magazin für das Neueste aus der Physik und Naturgeschichte*. (ed. Georg Christoph Lichtenberg in Gotha). Gotha: Carl Wilhelm Ettinger. 3/3: 34-39.

Hadži, Dušan. 2014. Spomin vode – kar rabi homeopatija in kaj ponuja sodobna znanost? *Acta Chimica Slovenica*. 61: S145–150.

Hagenbach-Bischoff, Jacob Eduard. 1872. Versuche über Fluorescenz, *Ann.Phys.* 146 (222/5): 65-89, (222/6): 232-257, (222/7): 375-405, (222/8): 508-538.

Haldane, Duncan. 1978. *An extension of the Anderson model as a model for the mixed Valence Rare Earth materials*, PhD at Cambridge University, UK.

Haldane, Duncan. October 31, 1988. Model for a Quantum Hall Effect without Landau Levels: Condensed-Matter localization of the "Parity Anomaly". *Physical Review Letters*, 61 (18): 2015-2018.

Haldane, Duncan. 2001. Stripes and Pairing in the $\nu = 5/2$ Quantum Hall Effect. *Open Problems and Strongly correlated Electron Systems* (eds. Bonča, Janez; Prelovšek, Peter; Ramšak, Anton; Sarben Sarkar). Dordrecht; Springer Netherlands / Boston: Kluwer, Proceedings of the NATO Advanced Research Workshop, Bled, Slovenia, 26-30 April 2000, NATO Science II, Mathematics, physics, and chemistry; volume 15, 4: 203-213.

Haldane, John Burdon Sanderson. 1939. *The Marxist Philosophy and the Sciences*, Random House, Ayer Co. Translation: 1951. *Marxist philosophy and Science (Marksistična filozofija in znanost)*. Chapter II. Ljubljana: Cankarjeva založba.

Hallerstein, Avguštin. 1753. A Letter from Reverend Father Augustin Hallerstein, of the Society of Jesus, President of the astronomical College at Pekin in China, to Dr. Mortimer, Sec. R. S. Dated Pekin, Sept. 18, N. S. 1750, Translated from the Latin by Tho. Stack, M. D. and F. R. S. *Phil.Trans.* 1751-1752. 47: 319-323.

Hallerstein, Avguštin. 1772. Lucis borealis Pekini sub Elevatione Poli 39.54 a R. P Hallerstein observatam. *Ephemerides astronomicae* (ed. Hell, Maximilian) 1772, Viennae 1771. 16: 250-251.

Du Hamel (Duhamel), Joannis Baptistae. 1681. *Operum philosophicorum. Tomus I astronomia physica; de meteoris et fossilibus: de consensu veteris et novae philosophiae. Pars secunda... IV. de corporis affectionibus; V. de mentre humanas; VI de corpore animato*. Norimbergae: Johan Zieger & literis Christophor Gerhard (FSLJ-649 2g 28; V (Valvasor's book)).

Du Hamel, Joannis Baptistae; Colbert, Jacques-Nicolas. 1678. *Philosophia Vetus Et Nova Ad Usum Scholæ Accommodata In Regia Burgundia novissimo hoc biennio pertractata Tomvs Primvs Qui Institutiones Logicas, & Logicam ipsam continent*. Paris Michallet. Volumes 1-4, 9 pages of introduction, 452 pages in 12°. Reprints: 1681. *Philosophia vetus et nova ad usum scholae accomodata, in regia Burgundia olim pertractata. Tomus primus [-sextus] [...] Editio altera multo auctior & emendatior*. Paris Michallet. 6 volumes in-12; Separately printed volumes 1-3 and 4-6: 1682. Noribergae: Ziegerus, 849 pages; 1736-1730. *Philosophia vetus et nova*, Venetiis: Franciscus Pitteri (tomus 4-5 Physica generalis) & Jacobum Zatta (tomus 1-3 (Logica, Philosophia moralis, Metaphysica). Tomus 6: Physicae pars tertia, 6 volumes in-12 (FSLJ-18 g 43, dedicated to Nic. Colbert conjautori Rethromagni (therefore Jacques-Nicolas Colbert).

Han, Qi (韓琦); Jami, Catherine. 2003. The Circulation of Western Mathematics at the Court during the Kangxi Period: A Case Study of the Compilation of the Suanfa Zuanyao Zonggang by Antoine Thomas. *Ziran Kexueshi Yanjiu (Studies in the History of Natural Sciences)* 22: 145-156.

Handl, Aloiz (Alois). 1867. Beiträge zur Molekulartheorie. (Sitzung 31 October 1867). *Wien.Ber.* II. 56: 569-578. Abridged: 1867. *Anzeiger der Österreichischen Akademie der Wissenschaften, Mathematisch-Naturwissenschaftliche Klasse.* 4/28: 236-237.

Handl, Aloiz (Alois). 1872. Über die Constitution der Flüssigkeiten. Beiträge zur Molekulartheorie. II. (14th meeting (Sitzung) 10 May 1872). *Wien.Ber.* II. 65: 377-388.

- Handl, Aloiz (Alois). 1872. Über den Zustand gesättigter und übersättigter Lösungen (Beiträge zur Molekulartheorie. III.) *Wien.Ber. II.* 66: 136-142 (noted at meeting on 10 July 1872). Abridged Reprint: 1872. Ueber den Zustand gesättigter und übersättigter Lösungen. *Carl's Rep.* 8: 379.
- Handl, Aloiz (Alois). 1872. Ueber den Welt-Aether und die Naturkräfte. *Neue Freie Presse. Abendblatt.* Wien, Donnerstag, den 27. Juni 1872. p. 4; Donnerstag, den 18. Juli 1872, p. 4; Donnerstag, den 12. September 1872, p. 4.
- Handl, Aloiz (Alois). 1874. Über die Ausdehnung der festen Körper mit steigenden Temperaturen. (Beiträge zur Molekulartheorie. IV.) *Wien.Ber. II.* 70: 505-518 noted at 25th meeting on 12 November 1874). Separate reprint: 1875. Wien.
- Handl, Aloiz (Alois). 1875. Weitere Beiträge zur Molekulartheorie. *Wien.Ber. II.* 72: 102-114 (read at meeting on 10 June 1875, noted at meeting on 17 June 1875).
- Hans, Nicholas. 1953. UNESCO of the eighteenth century la loge des neuf sœurs and its venerable master, Benjamin Franklin. *Proceedings of the American Philosophical Society* 95/5: pp. 513-524.
- Hantschk, Christian. 1988. *Johann Joseph Prechtl und das Wiener Polytechnische Institut.* Wien/Köln/Graz: Böhlav Verlag.
- Hanžek, Branko. 2017. Tehničar Franjo Ivan Havliček (1906. – 1971.) (Technician Franjo Ivan Havliček (1906-1971)). *Povijest i filozofija tehnike / radovi EDZ sekcije 2012. - 2016. godine (History and philosophy of technology - works of the EDZ (Elektrotehničko društvo Zagreb) section from 2012 to 2016)*, (ed. Benčić, Zvonko; Moser, Josip). Zagreb: Kiklos – krug knjige d.o.o., pp. 66-74.
- Harig, Gerhard Ernst Friedrich (Garig, Гариг). 1936. "Jubilee" of Roentgen in the "Third Empire" ("Jubilej Rentgena" v "tret'ej imperii", "Юбилей Рентгена" в "Третьей империи"). *Архив истории науки и техники (Arhiv istorii nauki i tehniki, Archive of history of science and technology)*. Moscow and Leningrad. Serie 1 volume VIII (vyp. VIII), pp. 301-308.
- Harré, Rom. 2002. *Great Scientific Experiments.* New York: Dover.
- Harsdörffer, Georg Philipp; Schwenter, Daniel. 1636. *Daniel Schwenter... Deliciae mathematicae et physicae, oder, Mathemat. Und philosophiche Erquickstunden darinnen sechs-hundert drey und sechs sig schöne, liebliche und annehmliche Kunststücklein.* Nürnberg: Jeremia Dümmler. Second and third Harsdörffer's parts printed in 1651.
- Hartman, Bruno. 1983. Slavjanofil Ivan Sergejevič Aksakov v Mariboru leta 1860 (Maribor in the year 1860). *Časopis za zgodovino in narodopisje.* 54 (19)/1–2: 125–144.
- Hartman, Bruno. 1985. Knjižnica mariborske realke (Realne gimnazije) (1870–1941) (Library of Maribor Real Grammar School). *Časopis za zgodovino in narodopisje.* 56/2: 139–162.
- Hartman, Bruno. 1991. Knjižnica v Mariboru (Library in Maribor). *Maribor skozi stoletja, Razprave I* (ed. Curk, Jože). Maribor: Obzorja. 313–414.
- Hartman, Bruno. 2001. *Kultura v Mariboru.* Maribor: Obzorja.
- Hartman, Bruno. 2007. Mariborsko filharmonično društvo. *Časopis za zgodovino in narodopisje.* 78 (43/2–3): 79–120.
- Hartman, Bruno. 2009. *Maribor – dogajanja in osebnosti.* Maribor: Litera.
- Haschek, Eduard; Lindenthal, Otto Theodor. January 23, 1896. Ein Beitrag zur praktischen Verwerthung der Photographie nach Röntgen. *Wiener klinische Wochenschrift* 9/4: 63-64 (at Franz-Serafin Exner's Vienna's second Physics Institute, published the first-ever angiogram in the world).
- Hashimoto, Sokichi (橋本宗吉). 1940. *Oranda shisei erekiteru kyurigen (阿蘭陀始制エレキテル究理原*, first edition 1813, reprint 1857. *Ansei.* 4:); *Erekiteru yakusetsu* (first edition 1811. Osaka. Reprint: 1857. *Ansei.* 4:); *Kotei Kyurigen kohon* (3).

Tokyo: Hashimoto Donsai Sensei Hyakunen Kinenkai. Horiguchi.

Hashimoto, Takehiko. 2009. *Historical Essays on Japanese Technology*. Tokyo: University of Tokyo Center for Philosophy.

Hauksbee, Francis. 1704. An experiment to show the causes of the descent of the mercury in a barometer in a storm. *Phil. Trans.* 24/292 (17051231): 1629-1630.

Hauksbee, Francis. 1709. *Physico-mechanical experiments on various subjects Containing an account of several surprizing phenomena touching light and electricity ... Together with the explanations of all the machines ... and other apparatus us'd in making the experiments*. London: R. Brugis. Italian translation: 1716. Florence: Jacopo Guiducci & Santi Franchi.

Hauksbee, Francis. 1719. *Physico-Mechanical Experiments on various subjects. To which is added, a supplement, containing several new experiments not in the former edition*. London: J. Senex & W. Taylor.

Hauptman, Herbert Aaron. November 1989. The Phase Problem of X-ray Crystallography. *Physics Today*. 24-29.

Hausmann, Friedrich. 1994. Die Grafen zu Ortenburg und ihre Vorfahren im Mannesstamm, die Spanheimer in Kärnten, Sachsen und Bayern, sowie deren Nebenlinien. In: Ostbairische Grenzmarken. *Passauer Jahrbuch für Geschichte Kunst und Volkskunde*. Nr. 36, Passau.

Haüy, Abbé René Just. 1784. *Essai d'une théorie sur la structure des cristaux: appliquée a plusieurs genres de substances cristallisées*. Paris: Gogué & Née de la Rochelle libraires quai des Augustins près le Pont Saint-Michel(is).

Haüy, Abbé René Just. 1801. *Traité de Minéralogie* 1-5. Paris: Louis de l'imprimerie de Delance / Paris: Bachelier (Zois' library now NUK-91587). Abridged version: 1806. *Tabelau méthodique des espèces minerales, présentant la série complète de leur caractères, et la nomenclature de leur variétés,*

extrait du traité de mineralogie de M. Haiüy, et augmenté des nouvelles découverts; auquel on a joint l'indication des gisemens de chaque espèce, et la description abrégé de la collection de mineraux du muséum d'histoire naturelle par Jean-André-Henri Lucas. Paris: Levrault, Schoell et c[ompagnie] (Zois' library now NUK: GS I 2204).

Haüy, Abbé René Just. 1806. *Traite élémentaire de physique*, Two-part edition, Paris (The book is not in Wilde's catalogue nor in Zois' library listings. In Čop's Census it was noted as NUK-22077). Translation from French of Johann Georg Ludolph Blumhof with an introduction of Johann Heinrich Voigt: 1804. *Gründlehre der Physik* in 2 parts. 8°. Wien: Wien: Landes-Industrie-Comptoirs (Zois' library now NUK-8504).

Haüy, Abbé René Just. 1809. *Tableau comparatif des résultats de la cristallographie et de la d'analyse chumique*. Paris: Courciuer (NUK-9086).

Haymonn, Joseph Anton. 1758. *Dissertatio physico medica de aire*. Vienna: Kaliwoda (W-1432, NUK-8184; Erberg's Physics 25).

Heidmann, Johann Florian Anton. 1799. *Vollständige auf Versuche und Vernunftschlüsse gegründete Theorie der Elektrizität für Aerzte, Chymiker und Freunde der Naturkunde 2. Bd.* Wien: Gedruckt mit J.C. Schuender'schen Schriften im k.k. Taubstummen-Institute.

Heidmann, Johann Florian Anton. 1804. *Zuverlässiges Prüfungsmittel zur Bestimmung des wahren von dem Scheintode: nebst neuen physiologischen Erfahrungen aus der Anwendung der verstärkten galvanischen Elektrizität auf den thierischen Organismus*, Wien: Camesina.

Heidmann, Johann Florian Anton. 1806. *Vollständige auf Versuche und Vernunftschlüsse gegründete Theorie der galvanischen Electricität für Ärzte, Chemiker und Freunde der Naturkunde Band 1*, Wien: Kupfer. Abridged comment by M.Guyton (Guyton de Morveau): 1807. *Annales de Chimie*, Tom 61, pp. 70-. Translation: 1807. *Theory of Galvanic electricity, founded on experience*. *Philosophical Magazine Series 1*, 28/110 (July 1807): 97-104.

- Heilbron, John Lewis. 1979. *Electricity in the 17th and 18th Centuries: A Study of Early Modern Physics*. University of California Press.
- Heilbron, John Lewis. 1993. Weighing Imponderables and Other Quantitative Science Around 1800. *HSPS*, Supplement. 24/1.
- Heimbach, Mathia (Matthia). 1703. *Florilegium Argumentorum*. Köln: Noethen. Reprints: 1708. *Florilegium Argumentorum*. Köln: Noethen; 1730. *Philosophia Argumentosa Quondam Florilegium Argumentorum Sive Ars Practica Inveniendi Medium nuncupata, Theses Philosophicas Acriter In Utamque Partem disputatas exhibens, Hac Editione Tertia correctior, novisque Argumentis cumulator, Authore R. P. Matthia Heimbach S. J. Olim in Celeberrima Ubiorum Universitate Philosophiae Professore ordinario*. Köln: Servatius Noethen; 1747. *Philosophia argumentosa quondam florilegium argumentorum sive ars practica inveniendi medium nuncupata, theses philosophicas acriter in utramque partem disputatas exhibens*. Köln (Coloniae): Noethen. Fourth edition (FSLJ-17 d 103).
- Heinlein, Petri Henrici ordini S. Benedicti. 1675. *Disputatio Physica de mundo et cielo, de elementi et de meteoris... de principiis rerum naturalium & causis... universitatis Salisburgensis*. Salzburg: Mayr (ST-22/83 109^f; NUK-8289 »Sitticensis« (from Stična Library). Bind to much shorter: Heinlein. 8 July 1675. *Quaestiones Selectae ex Physica seu rerum naturalium scientia...* Salzburg (NUK-8290).
- Heisenberg, Werner. 1969. *Der Teil und das Ganze. Gespräche im Umkreis der Atomphysik*. München, R. Piper. Translation with Adlešič's foreword: 1977. *Del in celota, pogovori v območju atomske fizike*. Celje: Mohorjeva družba / Maribor: Mariborski tisk.
- Heisenberg, Werner. 1945. *Wandlungen in den Grundlagen der Naturwissenschaft: sechs Vorträge von Werner Heisenberg (Wandlungen der Grundlagen der exakten Naturwissenschaft in jüngster Zeit. - Zur Geschichte der physikalischen Naturerklärung. - Prinzipielle Fragen der modernen Physik. - Gedanken der antiken Naturphilosophie in der modernen Physik. - Die Goethesche und die Newtonsche Farbenlehre im Lichte der modernen Physik. - Die Einheit des naturwissenschaftlichen*
- Welbildes)*. 6th Edition, Leipzig: S. Hirzel (printed by A. Pries), Translated by Mladen Klepac with comment of Tomislav Petković; Heisenberg, Werner. 1998. *Promjene u osnovama prirodne znanosti, šest predavanja. Slika svijeta suvremene fizike; Razvoj kvantne teorije i njezinih tumačenja na Heisenbergovu tragu*. Zagreb: Kruzak.
- van Helden, Anne C. 1991. The age of the air-pump, *Tractrix*, 3: pp. 149-172.
- Hellemans, Alexander. 2000. 2000 Physics Nobel Prize, *Europhysics news* 31/6 (November / December 2000): 29.
- Hellyer, Marcus. 1998. *The last of the Aristotelians: The transformation of Jesuit Physics in Germany 1690–1773*. Unpublished PhD dissertation. San Diego: University of California.
- Hellyer, Marcus. 1999. Jesuit Physics in eighteenth-century Germany: some important continuities, In: *The Jesuits cultures, Sciences, and the Arts 1540-1773*. Toronto: University of Toronto Press (Ed. John W O'Malley; Johann Bernhard Staudt & all), pp. 538-554.
- Hellyer, Marcus. 2005. *Catholic Physics: Jesuit natural philosophy in early modern Germany*. Notre Dame, Indiana: University Press.
- Hellwag, Christoph Friedrich. 1781. *Dissertatio inauguralis physiologico medica de formatione loquela. Praes. Prof. Gottlieb Konrad Christian Storr; Christoph Friedrich Hellwag*. Tübingen: Literis Fuesianis.
- Hellwag, Christoph Friedrich. 1818. *Euklid's Eilfter Grundsatz als Lehrsatz bewiesen*. Hamburg: Hoffmann.
- Hellwag, Christoph Friedrich. 1824. *Physik des unbelebten und des belebten entwickelt unter forschung nach der ursache der fortgesetzten bewegung*. Hamburg: August Campe.
- Hellwag, Christoph Friedrich. 1835. *Newtons Farbenlehre aus ihren richtigen Principien berichtet: (mit 2 Steintafeln (with 2 tables))*. Lübeck: Rohden.

Hellweg, Christoph Friedrich; Jacobi, Maximilian. 1802. *Erfahrungen über die Heilkräfte des Galvanismus, und Betrachtungen über desselben chemische und physiologische Wirkungen, mitgetheilt von Christoph Friedrich Hellweg ... nebst Beobachtungen bey der medizinischen Anwendung der Voltaischen Säule von Maximilian Jacobi.* Hamburg: Perthes.

Helmont, Jan Baptista van. 1648. *Ortus Medicinae. Id est, initia physicae inaudita. Progresus medicinae novus, in marborum ultionem ad vitam longam.* Amstelodami: Ludovic Elzevir (S; 800 pages and about 300 pages of appendixes; Bind to Helmont's opera omnia of medicine). Reprints: 1651 (FSKA); 1652. Amstelodami: Elzevir (NUK-11620).

Herbert, Joseph. 1772. *Theoria phaenomenorura electricorum (conscripta a J. Herbert): Adsertiones ex universa philosophia, quas In... univ. Viennensi anno ... 1772 ... propugnandas suscepit Fuchs Carolus.* Vienna: Thoma Trattner (Zois' book now NUK-GS 8392; NUK-8397, NUK-8387, two copies NUK-8210). Reprint: 1778. *Theoriae phenomenorum electricorum: quae seu electricitatis corpore in deficiens traiectu, seu sola atmosphaerae alectricae actione gignuntur.* Second edition. Vindobonae: Josephi nob. de Kurtabök.

Herbert, Joseph. 1773. *Dissertatio de Igne, Triplicem illius statum complexa, quum fluidum elasticum est, caloremque efficit, quum motu rapidissimo a corporibus evibratus lux est, quum denique irretitus, ac velut vinculus e corporibus gignitur aut sua in libertate exsistens ab his absorbetur.* Vienna: Thoma Trattner (Wilde-1508 now NUK-8390).

Herbert, Joseph. 1773. *Dissertatio de aquae, aliorumque nonnullorum fluidorum elasticitate.* Vienna: Thoma Trattner. Ambschell's German translation: 1778. *Josephs v. Herbert der Weltweisheit Doktors, und k. k. öffentlichen, und ordentlichen Lehrers der Physick an der hohen Schule zu Wien Abhandlung von der Federkraft des Wassers, und einiger anderen flüssigen Körper : Aus dem Lateinischen ins Deutsche übersetzt von Anton Ambschell, der Weltweisheit Doktor, und k. k.*

öffentlichen, und ordentlichen Lehrer der Physick an der Akademie zu Laybach. Laibach: Eger.

Herrmann, Emil. 1871. Formel für Spannkraft gesättigter Dampfe. *Wien.Ber.* II (June-July) 64: 623-650. Presented to the Academy on 12 October 1871.

Herrmann, Emil. 1875. Vollständige Theorie des gesättigten Wasserdampfes (Theorie der gesättigtes Dampfes). *Zeitschrift des österreichischen Ingenieur- und Architekten-Vereins (Österreichische Ingenieur- und Architekten-Zeitschrift, ÖIAZ).* 27/8: 145-152, 27/10: 185-193.

Herrmann, Emil. 1876. Ueber die spezifische Wärme und die wahre Wärmekapazität der Körper. *Ann. Phys. Ergänzungsband (Supplementary volume 7):* 134-154 (19 pages). Simultaneous print: *Dinglers Polytechnischen Journal.*

Herrmann, Emil. 1876. Ueber (Über) den Ausfluss permanenten Gase. *Zeitschrift des österreichischen Ingenieur- und Architekten-Vereins (Österreichische Ingenieur- und Architekten-Zeitschrift, ÖIAZ).* 28/2 (Band 28, Heft, 2, Blatter 5): Pages 37-44 (sent on 23 August 1875).

Herrmann, Emil. 1876. Zeuner és Fliegner kísérletei az állandó gázok kifolyásáról (Die Versuche von Dr. Zeuner und Fliegner über den Ausfluss der permanenten Gase, Experiments by Zeuner and Fliegner on the evolution of constant gases). *Zeitschrift des ungarischen Ingenieur- und Architekten-Vereines (Magyar Mernök-es Epitesz-Egylet Közlönye, Journal of the Hungarian Society of Engineers and Architects),* 10/12: 505-525.

Herrmann, Emil. 1879. *Compendium der mechanischen Wärmetheorie mit besonderer Berücksichtigung der Bedürfnisse der Maschinentechnik* (I. Derivation of the main equations of mechanical theory of heat. II. The behavior of gases. III. The behavior of vapors and liquids. IV, theory of caloric motors). Berlin: Ernst & Korn, 242 pages.

Hermelink, Heinrich. 1976. *Die Matrikeln der Universität Tübingen.* Nendeln/Liechtenstein: Kraus.

Hero of Alexandria (Heron ho Alexandreus). 1589. *De gli automati overo machine se moventi libri due. Tradotti dal greco da Bernardino Baldi d'Urbino abbate di Guastalla*. Venetia: Girolamo Porro. Reprint: 1601. *Di Herone alessandrino De gli avtomati, ouero machine se moventi, libri due*. Venetia: Appresso Gio. Battista Bertoni, libraro al Pellegrino].

Hertz, Heinrich Rudolf. 1889. *Über die Beziehungen zwischen Licht und Elektrizität: Vortrag gehalten bei der 62. Versammlung deutscher Naturforscher und Ärzte in Heidelberg 1889*. Bonn: Strauß. Reprints: 1895. Bonn: Strauß; 1905. Stuttgart: Alfred Kröner; 1923. Leipzig: Alfred Kröner; Hertz, Heinrich Rudolf; Helmholtz, Hermann von; (Mayer, Julius Robert) (ed. Eduard Wildhagen). 1931/1932. *Über die Beziehungen zwischen Licht und Elektrizität. Raum und Kraft: aus der Werkstatt genialer Naturforscher; eine Auswahl aus den gemeinverständlichen Vorträgen und Aufsätzen von H. Helmholtz und H. Hertz; eingeleitet und erläutert von Eduard Wildhagen*. Berlin: Deutsche Buch-Gemeinschaft G.M.B.H. 291-306; 1987. *Von der Naturforschung zur Naturwissenschaft* (ed. Hansjochem Otto Autrum). Berlin/Heidelberg: Springer, 187-203.

Hertz, Heinrich Rudolf. 1887-1889. Untersuchungen ueber die Ausbreitung der elektrischen Kraft. *Wiedemann Annalen (Ann.Phys.)*. Reprints: 1892. Leipzig: Johann Ambrosius Barth; 1894. *Gesammelte Werke*, volume 2. Leipzig: Barth, 1894; Hertz, Heinrich Rudolf; Helmholtz, Hermann von; (Mayer, Julius Robert) (ed. Eduard Wildhagen). 1931/1932. Einleitung Übersicht zu den Untersuchungen über die Ausbreitung der elektrischen Kraft. *Raum und Kraft: aus der Werkstatt genialer Naturforscher; eine Auswahl aus den gemeinverständlichen Vorträgen und Aufsätzen von H. Helmholtz und H. Hertz; eingeleitet und erläutert von Eduard Wildhagen*. Berlin: Deutsche Buch-Gemeinschaft G.M.B.H. 261-290; 1989. Barcelona: Universitat Politècnica de Catalunya, D.L.

Hertz, Heinrich Rudolf. 1895. Sur une influence de la lumière ultra-violette sur la décharge électrique. *Les quantités* (ed. Abraham & Langevin). 261-269.

Hertz, Heinrich Rudolf. 1895. *Schriften vermischten Inhalts*. Leipzig (ed. Ph. Lenard). Reprint: 1987. Vaduz/Liechtenstein: Sändig-Reprint-Verlag.

Hess, Albert; presented by Marie Alfred Cornu. 1894. *Sur une application des rayons cathodiques à l'étude des champs magnétiques variables*. *C.R.* Second Semester, 119/1: 57-58. Simultaneous Print: Hess, Albert. 1894. *Sur une application de rayons cathodique à l'étude des champs magnétiques variables*. *La Lumière Électrique* (Paris, ed. Cornélius Herz). 14 July 1894, volume 53, 16th year, no. 28): pp. 91-92.

Hess, Albert. 1898. Reclamation. *Ann. Phys.* 64/3 (300/1): 622. Sent on 17 December 1897.

Hessler, J. Ferdinand. 1852. *Lehrbuch der Physik. Nach den Bedutrnissen der Technik, der Künste und Gewerbe, zum Gebrauche beim Unterrichte in technischen Schulen, so wie beim Selbstunterrichte*. 672 woodcuts. Wien: Braumüller.

Hieber, Castul. 1797. *Theses philosophicae*. Pedemontium: Riepel. Reprints: 1798. *Theses selectiores ex philosophia rationali ac morali una cum elementis matheseos quas in convent Cambensi P.P. Franciscanorum publice propugnadas exponit...* Ratisbona: Rotermundt; 1799. *Theses selectiores ex philosophia*. Pedemontium: Riepel,.

Hill, John (under pseudonym Sir Abraham Johnson). 1751. London: R. Griffiths. Reprint signed by John Hill: 1780. *A review or the works of the Royal Society of London Containing Animadversions on Such of the Papers as Deserve Particular Observation, In eight parts: under the several heads of arts, antiquities, medicine, miracles, zoophytes, animals, vegetables, minerals*. 2nd edition, London: J. Dodsley for the Lady Hill (Zois' book now NUK-8470).

Hill, Jonathan A.; E.B. Heffelfinger. 1983. *Scientific, Medical & Natural History Books: from the libraries of Prince Fürstenberg, Wolfgang Engelbert, Graf von Auersperg, and the Duke of Devonshire*, New York: Hill.

Hirn, Johannes (Johan) as PhD student of Carolus Reginaldus Sahlberg. 1819. *Dissertatio*

entomologica insecta Fennica enumerans.: Cujus particulam quartam consensu ampl. facult. philos. Aboënsis praeside Carolo Reginaldo Sahlberg phil. [et] med. doct. oecon. [et] hist. natur. profess. publ. [et] ord. collegii imp. med. assess. Soc. Imp. Nat. Studios. Moscov. [et] Soc. Imp. Oecon. Fenn. membro, publicae censurae submittit pro gradu philosophico Johannes Hirn, Wiburgensis. In auditorio theol. die 19 Junii 1819. H. a. m. c. PhD in Aboae (Aboa now Turku in modern southwest Finland): Frenckelliorum. (Noted as Art: Medic in Kraškovič's legacy inventory in Dubrovnik).

Hittorf, Johann Wilhelm. 1869. Ueber die Elektrizitätsleitung der Gase. *Ann. Phys.* 212/1 (136): 1-31, 212/2 (136): 197-234; Continuations: 1879. Ueber die Elektrizitätsleitung der Gase. *Annalen der Physik und Chemie*, 243/8: 553-631; 1879. Berichtigung zu dem Aufsätze: Ueber die Electricitätsleitung der Gase. *Annalen der Physik und Chemie*, 244/12: 671; 1883. Ueber die Elektrizitätsleitung der Gase. *Ann. Phys.* 255/5 (20): 705-755. 1884. Ueber die Elektrizitätsleitung der Gase. *Ann. Phys.* 257/1 (21): 90-139. Translation 1888-1890: On the conduction of electricity in gases / Electric discharge through gases. *Physical memoirs, selected and translated from foreign sources* (a collection of pamphlets and offprints in six volumes, made by the third Lord Rayleigh, and his son the fourth baron). Parts 1-3. London: Council of the Physical Society of London, Taylor and Francis. vol. 1, no. 2 (1888/1889), pp. 111-232, 317-335.

Hočevar, Franz. 1881. Über einige Versuche mit einer Holtz'schen Influenzmaschine. *Wien Ber. (Sitzungsberichte der mathematisch-naturwissenschaftlichen Classe der kaiserlichen Akademie der Wissenschaften Wien) Mat.nat. II* 83: 709-715. Abridged versions: *Anzeiger der k. Akademie der Wissenschaften, Wien*, 18, 1881, p. 79-80; *Beiblätter zu den Annalen der Physik und Chemie*. 1881. p. 801. Review of all paper: Lummer, Otto. 1881. *Die Fortschritte der Physik* (Berlin). 37: 902.

Hočevar, Franz. 1881. Über das Combiniren zu einen bestimmten Summe. Zur Lehre von der Theilbarkeit der ganzen Zahlen (30 pages). *Programm des k. k. Gymnasiums zu Innsbruck*.

Review of paper: Lazarus. 1881. *Jahrbuch über die Fortschritte der Mathematik*. Berlin. 152.

Hočevar, Franz. 1882. Ueber die Wheatstone'sche Brücke. *Zeitschrift für das Realschulwesen*, 7: 467-468.

Hočevar, Franz. 1906. Sind die Elemente der Infinitesimalrechnung an den Mittelschulen einzuführen oder nicht? *Jahresbericht der Deutschen Mathematiker-Vereinigung*, 15: 262-265. Simultaneous print: 1906. *Zeitschrift für das Realschulwesen*. Volume 31. Wien: Hölder.

Hoerni, Jean A. 1961. Planar Silicon diodes and transistors, *IRE Trans. Electron Devices*, Volume ED-8 (March 1961) number 2: 178.

Höflechner, Walter (ed.). 1994. *Ludwig Boltzmann, Leben und Briefe* (The first part of a book: Ludwig Boltzmann, Dokumentation eines Professorlebens). Graz: Akademisch Druck und Verlagsanstalt.

Höflechner, Walter. 2013. Stefan, Josef. *Neue Deutsche Biographie*. 25: 106.

Höfler, Janez. 1970. *Tokovi glasbene kulture na Slovenskem*. Ljubljana: Mladinska Knjiga (Juvenile books).

Höfler, Janez. 1978. *Glasbena umetnost pozne renesanse in baroka na Slovenskem*. Ljubljana: Partizanska Knjiga (Partisan books).

Hofmann, Donatus a Transfiguratione Christi Domini (Donat). 1754. *Donati a Transfiguratione Domini ... Apparatus ad philosophiam universam exegeticam, & dialecticam : subigendis praeparandisque ad philosophiae studium adolescentium ingeniiis ... seorsim ab auctoris opere Philosophico excusus*. 1-4. Campidonae (Kempten): Andreas Stadler (KKKRS; KSSKL; FSLJ-10 h 61/10 c 11-12 with propriety entry "ab ARP Vincentio Mariaschitz procuratus"). Reprints: 1766. Campidonae: Tschiderer; 1768. *Introductio in philosophiam universam veterem & novam exegeticam & dialecticam Usui & commodo studiosae juventutis antehac semel iterumque edita; Nunc tertiis curis ab Auctore recognita emendata & Scholarum usui magis etiam accomodata. T. I*

Philosophiæ partem Logicam seu rationalem complectens. T. 2 Philosophiæ partem Metaphysicam seu rectius Primam Philosophiam complectens. T. 3 Philosophiæ partem physicam seu naturalem complectens. T. 4, Philosophiæ partem ethicam seu moralem complectens. Lindaviae Otto.

Hoh, Theodor. 1867. Zur Geschichte der Fluorescenz, *Ann.Phys.* 131 (207/8): 658-659.

Hoh, Theodor. 1885. Die Stellung der Atomenlehre zur Physik des Aethers. Geschichtlich-physikalische Studie. *Program... Gymnasium zu Bamberg.* Bamberg: W. Gärtner.

Holonyak, Nick Jr. April 1992. John Bardeen and the point-contact transistor (Special Issue: John Bardeen). *Phys. Today.* 45/4: 36-43.

Holtz, Wilhelm. 1865. Ueber eine neue Elektrisirmaschine; von W. Holtz in Berlin. *Ann.Phys.* (5/6) 202-126/No. 9: 157-171. Reprint: 1866. *Polytechnisches Journal*, 179/27: 134-137.

Home, Roderick Weir. 2000. Volta's English Connection. *Nuova Voltiana*, 1: 115 - 132.

Horiguchi, Tachu (堀口多). 1978. *Erekiteru zensho tekiyo (エレキテル全書)*, (Selection of notes about a electrostatic device). *Toka zakki* volume 34. Tokyo: Kowa Shuppan (東京 : 恒和出版).

Horváth, Joannis Baptistae. 1767. *Physica Generalis*. Tyrnavia; Reprints: 1770. *Instutiones Physicae Particularis*. Tyrnavia (FSLJ-21 f 9; KLEKL); 1772. *Physica generalis quam in usum auditorum philosophiae conscripsit J. B. Horváth. Editio novissima & Physica particularis quam in usum auditorum philosophiae conscripsit.* 1-2. Augusta Vindel (Augsburg): Rieger (NUK-GS 8426); 1776-1777. *Physica generalis quam in usum auditorum philosophiae conscripsit & Physica particularis quam in usum auditorum philosophiae conscripsit.* Trnava (SSMULJ; NUK-GS 8189 & NUK-GS 8599); 1790. Budae (FSNM).

Horvat, Radoslav (ed.); Tesla, Nikola. 1988. *Radovi iz oblasti elektrotehnike*. Beograd: Naučna Knjiga (Science books).

Horvat, Rudolf. 1941. *Lika i Krbava: povijesne slike, crtice i biljeske*. Zagreb: Matica Hrvatska. Edition Kolo (Wheel) 6, two volumes as no. 31 (124 pages) and no. 32.

Horvat, Rudolf. 1941. *Dr. David Starčević (1840-1908): povodom 100-godnišnjice njegova rođenja*. Zagreb: Narodna tiskara. 32 pages.

Hoskin, Michael. 1978. The principal consequences of the discovery of the finite velocity of light for the development of astronomy in the eighteenth and nineteenth centuries. *Roemer et la vitesse de la lumière* (ed. Taton, René). Paris: J. Vrin. 235-246.

Hostetler Laura. 2007. Global or Local? Exploring Connections between Chinese and European Geographical Knowledge During the Early Modern Period. *EASTM.* 26: 117-135.

Hoško, Franjo Emanuel. 2002. *Franjevačke visoke škole u kontinentalnoj Hrvatskoj*. Zagreb: Kršćanska sadašnjost.

Houdek, František. 1872. Dějepis jednoty českých matematiků v Praze. Vydáný na oslavu památky založení „spolku pro volné přednášky z matematiky a fysiky“ před 10 lety, z kterého Jednota vznikla. *Jednota českých matematiků a fysiků (in Prague)*. pp. 9-65.

Hounshell, David A. 8 February 1980. Edison and the Pure Science Ideal in the 19th Century America. *Science.* 207: 612-617.

Hoyer, Sonja Ana. 1992: *Hiša Tartini v Piranu. Zgodovinski razvoj in likovna oprema*. Koper: Lipa.

Hrkać, Serafin. 1998. *Filozofijski manuskripti na latinskom jeziku u Bosni Srebrenoj*, Mostar: Ziral.

Hsia, Florence C. 2009. *Sojourners in a strange land: Jesuits and Their Scientific Missions in Late Imperial China*. Chicago/London: Chicago University Press.

Hübl, Franz. 1869. *Systematisch-geordnetes Verzeichnis derjenigen Abhandlungen, Reden und Gedichte, welche die an den inländischen*

Mittelschulen vorhandenen österreichischen, preussischen und baierischen Schulprogramme enthalten, mit einem Vorworte und einem Anhang, zusammengestellt von Hübl Franz, Prof. am k.k. Gymnasium in Czernowitz. Czernowitz (Chernivtsi): Josef Buchowiecki & Comp. books.google.si/books?id=shJMAAAAcAAJ&printec=frontcover&hl=sl#v=onepage&q&f=false, retrieved 18 January 2012

Huetius, Pierre Daniel. 1689. *Censura philosophiae Cartesianae (Against Cartesian Philosophy)*. Paris: Daniel Horthemels. Reprint: 1734. Venetiis: Joseph Lovisa (FSLJ-4 e 55; MINSPT with propriety entry: "Fi. Clementii Ex libris Conv. Pettoviensis").

Hummel, Carl; Elisabeth Gervais. after 1821. *Abhandlung über die Weinbereitung nach (by) Elisabeth Gervais. Frey übersetzt aus dem Französischen von Anton Albert Freyherrn v. Maskon (Anton Albert Moscon of Committees of the k. k. Agricultural Society in Styria and corresponding members of the Moravian = Silesian society of agriculture, nature and regional studies (Ausschusse der k. k. Landwirtschafts= Gesellschaft in Steyermark and correspondirendern Mitglieder der k. k. mährisch = schlesischen Gesellschaft des Ackerbaues, der Natur = und Landeskunde)); nebst einem Anhang der Hummel'schen Ankündigung des Wein- und Bier-Apparates, zu Folge k. k. Privilegiums; mit einer Abbildung der zur Weinbereitung gehörigen Geräthschaften*. Laibach: Ignac Alojz Kleinmayr, 56 pages.

Hummel, Karl. 1833. Erscheinungen und Theorie des Electrophors. (*Baumgartner's*) *Zeitschrift für Physik und verwandte Wissenschaften*. Wien. 2: 213-235 (NUK-11658).

Hummel, Karl. 1883. *Der moderne Versicherungsschwindel, hier besonders die Lebensversicherung, nicht wie sie von den Schönfärbern bis jetzt immer dargestellt wurde, sondern was sie ist, und wie sie betrieben wird*. Munich: Gotthold, 24 pages.

Hummel, Karl. 1883. *Noch ein Wort über Versicherungswesen, insbesondere die Lebensversicherung*. Munich: Gotthold, 30 pages.

Hurd, David Leonard; Kipling, John Jervis (ed.). 1964. *The Origins and Growth of Physical Science*. Volumes 1-2, Penguin Books. Both volumes based on: Schwartz, George; Bishop, Philip W. (eds.). 1958, 1959. *Moments of discovery*, New York: Basic Books.

Huygens, Christiaan. 1654. *Christiani Hugenii, Const. F., De circuli magnitudine inventa: accedunt eiusdem problematum quorundam illustrium constructions*. Leyden: Jean Elzevir & Daniel Elzevir Elzevier.

Huygens, Christiaan. 1690. *Traité de la lumière*. Leyden: Pierre van der Aa.

Hvale (Qualle), Mathia. 1513. *Habes hic amande lector textum parvali, quod adjunct phie (=philosophia) naturalis cum comentariis erudissimi viri magistri Mathi Qualle Carniolani, et College gymnasii Viennensis summa vigilantia e gravissimis authoribus decerptis, qui conducunt maxime, cim aliis, tum his, qui vie nominalium addicti proficiunt*. Hagenau: Joannis Rynman/Henric Gran (NUK-R 4499, Bookplate *Bibliot. Oberburgensi Episcopi Labacensi*; 179 pages; 19 cm). Reprint: 1517.

Ifko, Sonja. 2012. Zgrade radionica Südbahn željeznica u Mariboru i njihov utjecaj na urbanistički razvoj grada. *5th Pro Torpedo Annual Conference 25 to 26 May in Rijeka, Croatia. Collection of Summaries*. Rijeka: Pro Torpedo. 66–67.

Iijima, Sumio. 7 November 1991. Helical Microtubules of Graphitic Carbon. *Nature*. 354: 56-58.

Imhof, Maximus. 1792. *Epitome institutionum physices et Matheseos applicatae*. Monachii (Munche): Joseph Lentner. German translation: 1793. *Grundriß der öffentlichen Vorlesungen über die Experimental-Naturlehre welche auf Veranstaten der Churfürstlichen Akademie der Wissenschaften in München*. München: Joseph Lentner. Different version: 1797. *Institutiones physicae quas in usum auditorum suorum elucubravit*. Monachii (Munche): Joseph Lentner (Franciscans' Library of Novo Mesto (FSNM)).

Ingenhousz, Jan; (translator and editor Nicolaus Karl Molitor). 1782. *Johann Ingen-Housz k. k. Hofraths und Leibarztes, der königl. Gesellschaft der Wissenschaften zu London ... vermischte Schriften phisich-medizinischen Inhalts nebst einigen Bemerkungen über den Einfluß der Pflanzen auf das Thierreich; Mit Kupfertafeln, Uibersetzt und herausgegeben von Niklas Karl Molitor*. Wien: Johann Paul Krauß. Reprint: 1784. *Vermischte Schriften phisich-medizinischen Inhalts, Übersetzt und herausgegeben von Nicolaus Carl Molitor, 2. verbesserte und mit ganz neuen Abhandlungen vermehrte Auflage*. 1-2. Wien: Wappler (W-1517 and W-1518 now NUK-8221); Translation: 1785-1789. *Nouvelles experiences et observations sur divers object de physique*. Paris: T. Barrois le jeune.

Ingenhousz, Jan. 1779. *Experiments upon vegetables, discovering their great power of purifying the common air in the sun-shine, and of injuring it in the shade and at night... by Joihn Ingen-Housz*. London: P. Elmsy & H. Payne; Translations: 1780. *Expériences sur les végétaux*. Paris: Fr. Didot; 1787, 1789. *Expériences sur les végétaux*. 1-2. Paris: Barrois; 1786-1790. *Versuche mit Pflanzen, hauptsächlich über die Eigenschaft, welche sie in einem hohen Grade besitzen, die Luft im Sonnenlichte zu reinigen, und in der Nacht und im Schatten zu verberben; nebst einer neuen Methide, den castle der Reinheit und Heilsamkeit der atmosphärischen Luft zu grüfen. Aus dem französishen übersetzt von Joh. Andr. Scherer*. Vienna: Wappler.

Inglot, Marek, S.J. 1997. *La Compagnia di Gesù nell'impero Russo (1772-1820) e la sua parte nella restaurazione generale della Compagnia*. Roma: Editrice Pontificia Università Gregoriana.

Israel, Paul B. 1998. *Edison, A Life of Invention*. New York, Chichester, Weinheim, Brisbane, Singapore, Toronto: John Wiley & Sons, Inc.

Ivanchich, Jan; Reviczký, Antal; Planck, Joannes Baptista (Anonymous Edition). 1752-1755. *Universae matheseos brevis institutio theorico-practica ex operibus PP. Societas Jesu collecta*. Trnava: Typus Academicus (FSLJ-13 d 3; Erberg M40). Reprinted from: Planck, Joannes Baptista;

Gautruche, Pierre. 1746-1747. *Dilingae: formis academicis of heirs of Johann Caspar Bencard*.

Izarn, Joseph. 1805. *Leçons élémentaires de physique et chimie expérimentales*. Paris: Lerault & Schoell (Zois' book, the copy without Zois' binding in NUK-8348).

Jacquier, François; Thomas Leseur (Le Seur). 1739-1742. *Philosophiae naturalis principia mathematica. Auctore Isaaco Newtono, Eq. Aurato. Perpetuis Commentariis illustrata, communi studio PP. Thomae le Seur & Francisci Jacquier Ex Gallicanâ Minimorum Familiâ, Matheseos Professorum*. 3 volumes in 4. Geneve: Typis Barrillot & Filii.

Jacquier, François. 1755. *Elementi Di Perspettiva: secondo li principii di Brook Taylor; con varie aggiunte spettanti all'ottica, e alla geometria*. Roma: Giovanni Generoso Salomoni.

Jacquier, François. 1759. *Institutiones Philosophicae ad Studia Theologica potissimum acomodatae* Romae: Fratres Paleariniis. Reprint: 1762. *Institutiones Philosophicae ad studia theologica*. Venetiis: Simonis Occhi (propriety entry "conventus Labac 1765" in FSLJ-11 d 20-21 which has volumes 2 and 3 with part 3 about special physics, parts 4, 5, and 6, but not the first volume with first part containing logics and the second part with metaphysics and general physics). Reprint: 1766. *Institutiones Philosophicae ad Studia Theologica potissimum acomodatae... Physica Generalis et Particularis*. Graecii: Widmanstetter (NUK-5018 propriety entry of the Library of Society of Agriculture and useful arts; MINSPT propriety entry: "Ad usum fratris Clementis Kemper ord. Min. S. Franc. Convent. de Graecio 1777 nunc Fris Benigni 1779; Ex libris Conventus Pettoviensis IX III 59").

Jacquín, Joseph Franz baron. 1793. Wien: Christian Friedrich Wappler & Beck. Reprint: 1810. *Lehrbuch der allgemeinen und medicinischen Chymie. Zum Gebrauche seiner Vorlesungen entworfen von Joseph Franz Freyh. von Jacquín*. 1-2. Wien: C.F. Beck. (Italian translation as Jacquín's *Istruzione Chimiche* was never printed but anyway noted as

domestic translation of German title in Kraškovič's legacy inventory in Dubrovnik).

Jacquín, Nikolaus Joseph baron. 1783. *Anfangsgründe der medicinisch-practischen Chymie: zum Gebrauche seiner Vorlesungen*. Wien: Christian Friedrich Wappler.

Jäger, Gustav. 1908. Josef Stefan, *Allgemeine Deutsche Biographie*, 54: 448-451.

Jäger, Gustav. 1935. *Vortrag über Stefan in dessen Geburtsort (Lecture about Stefan in his place of birth)*. Klagenfurt.

Jakič, Ivan. 2001. *Sto gradov na Slovenskem (100 Castles in Slovenia)*. Ljubljana: Prešernova družba.

Jamnicky, Johann. 1880. Meteorologijska opažanja na c. kr. velikoj realci u Rakovcu. *Jahresber. der k. k. Ober-Realsch. in Rakovac 1879-80*. Zagreb: Albrecht. 25-32, 99-114

Jan, Mateja. 2000. *Provenienca knjig kapucinske knjižnice v Škofji Loki*. Graduate thesis (diplomska naloga Univerza v Ljubljani, Teološka fakulteta) mentor Benedik Metod. Co-mentor Kolar Bogdan. Brezje: self-publishing.

Iannaccone, Isaia. 1998. *Johann Schreck Terrentius: le scienze rinascimentali e lo spirito dell'Accademia dei Lincei nella Cina dei Ming*. Napoli: Istituto universario orientale.

Janeš, Lidija. 2000. *Stiške knjige (books) so mi povedale*. Graduate thesis (Diplomska naloga, mentorj France Martin Dolinar). Ljubljana: Oddelek za bibliotekarstvo Filozofske fakultete v Ljubljani.

Jaszlinszky (Jaszlinsky), Andrea S.J. 1756. *Institutionum physicae*. Turnaviae: Academicus Societatis Jesu (W-1439=NUK-8497 from the former Jesuit library of Ljubljana; KSSKL-Loka T 4; FSLJ-6471/2 g 27 (FSLJ-2 g 42) crossed out ex libris: Josephus Perger physice auditor 17 annos; ex libris not crossed out: ex libris Antonii Kersch 18 annario (Anton Kersch in 1810); bookplate (ex libris) crossed out: Hic liber spectat ad me Josephum d'Haræ Physices auditorum (= student of physics) 1803; bookplate (ex libris) on title page: Conventus

Castagnevicae (Kostanjevica above Gorizia) 1862); Reprints: 1757-1758; 1761. 800 pages, 16 tables.

Jelenič, Friderik, 11 December 1662. *Das Starcke Salomonische Wieb In Sittlicher Gleichständigkeit: In der ... Frawen Juditha Eleonora, Gräfin von Tattenbach/ geborner Gräfin von Forgacz, erfunden; Und Bey dero Leich-Begängnuß/ auch auffgerichten Traur-Gerüst zu schuldigen Ehren*. Graz: Widmanstetter.

Javellus, Chrysostomus Canapi. 1546. *Dn. Chrysostomus Iavelli... Ord. Praedicatorum... in universam moralem Aristotelis, Platonis, & Christianam philosophiam, epitomes in certas partes distinctae. Quae hoc tomo continentur, sequens pagina singillatim atque ordine indicabit*, Lugduni: Hieronymi De la Garde. Reprints: 1646. Lugduni: Garde; 1651. Lugduni: Garde (T).

Javellus, Chrysostomus Canapi. 1555. *Javelli Canapii, ordinis Praedicatorum Commentarii in Logicam Aristotelis. Ad disciplinae peripateticae normam et methodum exarati, et sedulo elimati*, Lugduni: Sebast. Bartholomeai Honorati (NUK-4717; NUK-4741). Reprints: 1556. Lugduni; 1560. Venetiis: Francisco Laurentini (NUK-4685 from the Upper Castle library according to Terpin); 1562. Lugduni; 1609. *Logicae Chrysostomi Javelli Ordinis Praedicatorum, compendium: opere ac doctrina iuxta librorum Logicae Aristotelis ordinem mirabili brevitate confectum, ab omnibus mendis, quibus antea scatebat, hac ultima editione singulari studio et fidelitate vindicatum*. Venetiis: Antonium Turinum (FSLJ-20 f 22).

Javellus, Chrysostomus Canapi. 1553. Lugduni. Reprint: 1555. *Chrisostomi Iauelli Canapicii quaestiones (Questiones) super libros Metaphysicae Aristotelis iuxta Thomisticae doctrinae dogmata decisae : cum suo indice copioso vt inspicienti apparebit : quae omnia recenti hac nostra editione, ut potuit fieri, diligentissime expolita sunt, atque elaborata*, Venetiis: apud Hieronymum Scotum (Gašper Žitnik's book noterd as Sum Caspari Sitnigkh Labacen[is], now NUK-4586).

Javellus, Chrysostomus Canapi. 1577. *D. Chrysostomi Iavelli Canapicii ordinis praedicatorvm ... Totius rationalis, naturalis, diuinæ ac moralis*

philosophiae compendium : innumeris ferè locis castigatum, & in duos tomus digestum ... : his adiecimus in libros Physicorum, De anima, & Metaphysicorum ... : præter hæc postremæ huic nostræ editionitertivm tomvm affiximus, qui eiusdem Javelli in sphæram tractatum, nec non in Aristotelis librum De sensu & sensato, et De memoria, & in quartum Meteorum doctissimas quæstiones nusquam antea impressas, continet (Quæstiones super quartum meteorol. et de sensu et sensato, memoria et reminiscencia Aristotelis). Venetiis: hæredem Hieronymi Scoti.

Javellus, Chrysostomus Canapi. 1534. *Questiones in octo libros De phisico[rum] auditu reveren. pa. fratris Chrisostomi Javelli Canapicii ... nuper edite & impressæ*, Venetiis: Thomam Ballarinum de Ternengo Vercellensem (POMPI).

Jemec, Marija. 2008. Dediščina vsakdanjosti: etnološka kulturna dediščina Občine Dol pri Ljubljani, *Iz dežele Jurija Vege: zbornik Občine Dol pri Ljubljani* (ed. Stane Omerzu). 1/1: 381-399.

Jenko, Bojan (author of introduction and head editor) et al. 1993. *Vakuumska tehnika za srednješolske predavatelje* Ljubljana: Društvo za vakuumsko tehniko Slovenije.

Jenko, Monika. 1997. Profesorju dr. Jožetu Gasperiču ob njegovem 65. rojstnem dnevu (Profesor Gasperič's 65th birthday). *Vakuumist.* 17/3: 30–31.

Jesuits-anonymous. 1752. *Universae matheseos brevis institutio theorico-practica ex opribus pp. Societatis jesu collecta. Complecens hac perima parte Arithmeticom, Geometriam, Trigonometriam, Mechanicam, Staticam, Hydrostaticam, Hydraulicam, Aerometriam.* Tyrnaviae: Academicis Societatis Jesu. Simultaneous print with the same title: Gautruche, Pierre SJ. 1752. Pedeponti: Gastl (FSLJ-3 h 26 with note Q157 crossed out).

Jettmar, Heinrich. 1879. Bestimmung der Bildorte und Wellenform der an Ebenen Flächen reflectiren und gebrochenen Lichtstrahle, auf elementare Wege. *Programm des k. k. Staats-Gymnasiums in Marburg* (Maribor) *Veröffentlicht von der Direction am Schlüsse des Studienjahres 1879*, Maribor: Edvard

Janšič (Marburg: Eduard Janschitz), pp. 3-26 and additional page with 7 illustrations-drawings.

Jettmar, Heinrich. 1883. Studien über die Strahlenbrechung im Prisma. *Programm des k. k. Staats-Gymnasiums in Marburg* (Maribor) *Veröffentlicht von der Direction am Schlüsse des Studienjahres 1883*, pp. 3–39 and additional page with six illustrations-drawings.

Jirō, Numata. 1992. *Western Learning. A Short History of the Study of Western Science in Early Modern Japan*. Tokyo: The Japan-Netherlands Institute.

Joffe (Ioffe), Abram Fedorovich. 1983. *Встречи с физиками: мои воспоминания о зарубежных физиках / Vstrechi (Vstreči) s fizikami: moi vospominaniia o zarubezhnykh fizikakh (Meetings with physics)*. Leningrad: Nauka.

John, Johann Friedrich. 1817–1819. *Handwörterbuch der allgemeinen Chemie*. Leipzig/Altenburg: F. A. Brockhaus.

Joshi, Chandrasekhar "Chan" Janardan; Corkum, Paul Bruce. January 1995. Interactions of ultra-intense laser light with matter. *Phys. Today* 48(1): 36–43.

Jotzu, Gregor; Messer, Michael; Desbuquois, Rémi; Lebrat, Martin; Uehlinger, Thomas; Greif, Daniel; Esslinger, Tilman. 2014. Experimental realisation of the topological Haldane model with Ultracold fermions. *Nature*, 515 (7526): 237-240.

Jovanović, Branimir. 1998. Nikola Tesla – Sto godina daljinskog upravljanja. In: *Nikola Tesla – Sto godina daljinskog upravljanja*. Beograd: Muzej Nikole Tesle. 8-19.

Jovanović, Branimir. 2001. *Tesla: duh, delo, vizija*. Beograd: Freemental.

Jozelj, Sonja. 1992. Pouk kemije na Slovenskem do prve svetovne vojne. *Šolska kronika*. 25: 38-47.

Juncker, Johann; Stahl, George Ernst; Becher, Johann Joachim. 1730. *Conspectvs Chemiae Theoretico-Practicae: Tomus 1-2. In Forma*

Tabvlarvm Repraesentatvs, In Qvibvs Physica, Praesertim Svbtterranea, Et Corporvm Natvralivm Principia, Habitvs Inter Se, Proprietates, Vires Et Vsvs, Itemqve Praecipva Chemiae Pharmacevuticals Et Mechanicae Fvndamenta E Dogmatibus Becheri Et Stahlī potissimum Explicantur, eorundemqve et aliorum celebriū chemicorū experimentis stabiliuntur. Halae Magdeburg: Orphanotropheum (Freyer's transcript in SI_AS 863, printed version not preserved in Slovenian libraries).

Jungnickel, Christa; McCormmach, Russell. 1986. *The Intellectual mastery of nature. 2nd part: The now Mighty Theoretical Physics 1870–1925.* The University of Chicago Press.

Jurik, Josefina. 1884. *Jurik's Adress-buch der Stadt Marburg: mit einem ausführlichen Wohnungs-Anzeiger, Schematismus der Behörden, des Handels-, Fabriks- und Gewerbewesens und geschichtlichen, topografischen und statistischen Daten.* Marburg/Maribor: J. Jurik & Johann Leon.

Južnič, Stanislav. 12 March 1979. Einsteinov prispevek k razvoju naravoslovne filozofije. *Tribuna. Študentski časopis*, 28/10-11 (year 1978/79): 8-9.

Južnič, Stanislav. March 3, 1979. Mati narava se pritožuje. *Tribuna. Študentski časopis*. volume 28/no. 12 (Year 1978/79): p. 10.

Južnič, Stanislav. 1979. Študij inkomenzurabilnega faznega prehoda v Rb_2ZnCl_4 z jedrsko magnetno resonanco Rb^{87} . *Nova proizvodnja, strokovna revija za tehnična področja*. 30/1-6: 47-48.

Južnič, Stanislav. 1980. (with R. Blinc, S. Žumer, V. Rutar and J. Seliger) ^{87}Rb Spin-Lattice Relaxation in the Incommensurate Phase of Rb_2ZnCl_4 . *Phys. Rev. Letters*. 44/9: 609-612.

Južnič, Stanislav. 1980. *Študij inkomenzurabilnega faznega prehoda v Rb_2ZnCl_4* . Diplomsko delo na Univerzi v Ljubljani.

Južnič Stanislav. 1983. Razvoj fizike med Newtonom in kvantno mehaniko. Ljubljana/Fara pri Kostelu: Magistrska naloga na oddelku za zgodovino filozofske fakultete.

Južnič, Stanislav. 1993–1994. Zgodovina vakuumske tehnike (X–IV. del), *Vakuumist*. 13/3: 21–26, 13/4: 25–29, 14/1: 27–31, 14/2: 26–30.

Južnič, Stanislav; Nemanič, Vinko. 1996. Iznajdba in razvoj katodne elektronke in drugih vakuumskih elementov za televizijo, 1. del (Invention and development of cathode ray tube and other vacuum elements for television, 1st part). *Vakuumist*, 16/1: 19-24.

Južnič, Stanislav. 1997. Zgodovina raziskovanja luminiscentnih snovi, 3. del (History of development of luminiscent materials, Part III). *Vakuumist*, 17/2: 20-25.

Južnič, Stanislav. 2002. Vakuumski balon. *Vakuumist*. 22/4: 24–27.

Južnič, Stanislav. 2002. Fizik Karel Robida (1804-1877), pisec prve slovenske knjige o fiziki in učitelj Jožefa Stefana. *Zbornik za zgodovino znanosti in tehnike*, Ljubljana, SM. 15-16: 112-161.

Južnič, Stanislav. September 2004. Answer to Planck – Written in Mileva Einstein's Handwriting. In: Krstić, Djordj. *Mileva & Albert Einstein Their Love and Scientific Collaboration*. Radovljica: Didakta. 236-246. Translation: 2005. *Odgovor Plancku*. Novi Sad: Srbska Matica.

Južnič, Stanislav. 2004. Raziskovanje vakuuma na (dunajskem) fizikalnem inštitutu Jožefa Stefana. *Vakuumist*. 24/4: 24-32.

Južnič, Stanislav. 2005. *History of Kostel: 1500-1900: between two civilisations*. Camp Hill (Pennsylvania): The Slovenian Genealogy Society International (SGSI). Extended translation: 2008. *Zgodovina Kostela 1500-1900*. Fara: Občina Kostel.

Južnič, Stanislav. 2007. Dr. Karel Robida (1804-1877), gimnazijski profesor in razrednik Jožefa Stefana (Ob 130letnici smrti). *Šolska kronika*. 16(40)/1: 7-15.

Južnič, Stanislav. 2009. *Dvig iz pragozda in zaton vanj: Razvoj Kočevske in sosednjih dolin (Osilniška, Dragarska, Poljanska) (1498-2009)*. Fara.

Južnič, Stanislav. 2010. *Zgodovina raziskovanja vakuumskih tehnik 2*. Ljubljana: DVTS.

Južnič, Stanislav. 2012. Toynbee Nonsense Book for Slovenians. *Studia Historica Slovenica (Maribor)*. 12/1: 21–54.

Južnič, Stanislav. 2016 November. Four centuries of Slovenian Vacuum Techniques from Auersperg-Guericke's experiment (1657) to Tesla's Maribor (1878/1879) (on 400th anniversary of birth of the Prince Johann Weikhard Auersperg (1615-1677)), *Vacuum* 136 (2017) 60-63.

Južnič, Stanislav. 17 April 2010. Jožef Stefan v Slovenski fiziki s posebnim ozirom na belokranjske znanstvenike. 5. Zborovanje Društva učiteljev zgodovine Slovenije, Črnomelj. *Vpliv znanstvenih odkritij in tehnoloških inovacij na spremembe v družbi*. Book of abstracts.

Južnič, Stanislav. 2001. Ludwig Boltzmann in prva študentka fizike in matematike slovenskega rodu. *Kvarkadabra*. Internetni časopis (ed. Sašo Dolenc). Ljubljana.

Južnič, Stanislav. 4 March 2016. Uresničene nadzvočne sanje izpod Gorjancev. Ob stoletnici smrti Ernsta Macha: dolga pot do ugotovitve, da sta za neznosne rane na bojišču krivi hitrost in oblika izstrelka. *Delo Znanje*.

Južnič, Stanislav. April 2016. Prvi fotograf nadzvočnih izstrelkov. Ob 100. obletnici smrti Ernsta Macha in poldrugem stoletju torpedov. *Življenje in tehnika*. 4: 42-51.

Južnič, Stanislav. March 2016. Ob 100-letnici smrti Ernsta Macha, ob 150-letnici izuma torpeda. Pionirski posnetki nadzvočnih bojnih izstrelkov sina graščaka spod Gorjancev (ob stoletnici smrti Ernsta Macha, ob sto-petdesetletnici izuma torpeda). *Revija Obramba*. 3: 51-55.

Južnič, Stanislav. 11 May 2016. Prva fotografiranja nadzvočnih izstrelkov sina graščaka spod Gorjancev za snemanje sodobnih plazemskih turbulenc v magnetronu (ob stoletnici smrti Ernsta Macha). *Vakuumist* 36/1: 19-26.

Južnič, Stanislav. 20 May 2016. Učitelji Salchera i Macha (U povodu stogodišnjice Machove smrti) Salcher & Mach's teachers (On centennial of Mach's death). VII Međunarodna konferencija o industrijskoj baštini posvećena temi; Torpedo – povijest i baština; 150. godišnjica izuma Luppis-Whiteheadova torpeda; 7th international conference on industrial heritage Torpedo – history and heritage; 150th Anniversary of the invention of the "Luppis-Whitehead" torpedo; Rijeka, 19. – 21. svibnja 2016. / *Rijeka, 19th – 21th May, 2016*. pages 50-51.

Južnič, Stanislav. May 2016. Pionirski posnetki nadzvočnih bojnih izstrelkov sina graščaka spod Gorjancev (ob stoletnici smrti Ernsta Macha). *Slatenska dolina in Machova dediščina pod Gorjanci* (ed. Marjan Hren). Novo mesto: Založba Snovanja Društva Upokojencev. 106-113.

Južnič, Stanislav. July 2016, Ernstove nadzvočne sanje izpod Gorjancev so se uresničile. (ob stoletnici smrti Ernsta Macha). *Rast* (Novo mesto), 27/1: 65-69.

Kacin, Marija. 2001. *Žiga Zois in italijanska kultura*. Ljubljana: ZRC SAZU.

Kahlbaum, Georg Wilhelm August; Schroeter, Paul; Wirckner (Wirkner), C. G. von. 1893, 1897. *Studien über Dampfspannungsmessungen*, Basel: B. Schwabe's Verlag (1st part of 1893 with paragraphs entitled *Quecksilberluftpumpe* on pages 84-88 and *Automatische Quecksilberluftpumpe* on pp. 162-164).

Kahlbaum, Georg Wilhelm August. 1894. Selbstthätige stetig wirkende Quecksilberluftpumpe nach dem Sprengel'schen System. *Ann. Phys.* 289/9 (53): 199-208.

Kahlbaum, Georg Wilhelm August. 1901. Glossen zu der selbstthätigen (selbsttätigen) Quecksilberluftpumpe, *Ann. Phys.* 311/11 (6): 590-602.

Kangro, Hans. 1976. Le developement de la thermodynamique de Clausius à Planck. *Table ronde du CNRS: Sadi Carnot et l'essor de la*

Thermodynamique, Paris 1974. Paris: Editions CNRS. 229-246.

Kapferer, Simon de Lypnica. 1778. *Theoremata philosophica ex prælectionibus P.F. Simonis Kapferer Ord. Min. Reform. prov. Tyrol. ... propugnabunt in Monasterio Halensi* (responding students:) *rel. FF. Juvenalis Watschinger, Tiburtius Rotlechner, Epiphanius Winterstöller, Hermenegildus Priller*. Oeniponte (Innsbrück): Johannes Thomas de Trattner (FSLJ-9 d 92).

Kapitsa, Piotr Leonidovich (Пётр Леонидович Капица). 1974. *Эксперимент, теория, практика: статьи, выступления*. Moscow: Nauka. 3rd revised edition: 1981. *Experiment theory practice (Эксперимент, теория, практика: статьи, выступления, Эксперимент, теория, практика: stat'i, vystupleniia)*. Moscow: Nauka.

Katanec, Sara. 2014. *The Perquisite of a Medieval Wedding: Barbara of Cilli's Acquisition of Wealth, Power, and Lands*. MA thesis, Budapest.

Kayser, Heinrich. 1908. *Handbuch der Spectroscopie. 4, Natürliche Farbstoffe der Pflanzen. Die Farbstoffe von Blut, Harn, Galle. Thierische Farbstoffe. Dispersion. Fluorescenz*. Leipzig: Hirzel.

Keill, John. 1702, 1705. *Introductio ad veram physicam*. Oxoniae: T. Bennet; Reprints: 1725, 1735, 1739. *Introductiones ad veram physicam et veram astronomiam. Quibus accedunt Trigonometria. De viribus centralibus. De legibus attractionis*. Leyden: Joh. & Herm. Verbeek; 1742. Mediolani: Franciscus Agnelli (FSLJ-12 b 25; FSNM); just astronomical part was translated by Le Monnier, Pierre-Charles: 1746. *Institution astronomique ou leçon elementaire d'astronomie, pour servir d'introduction a la physique céleste, & a la science des longitudes, avec de nouvelles tablis d'equation corrigées; et particulièrement les tablis du soleil, de la lune & des satellites, précédées d'un essai sur l'histoire d'astronomie moderne*. Paris: Guerin (Zois, NUK-7919); translation of Lulofs, Johannes: 1741. *Inleidinge tot de waare Natuur-en Steerkunde, of de natuur-en sterrekundige lessen van den heer Johan Keill...: waar by gevoegt zyn deszelfs verhandeligen over de platte en klootsche*

driehoeks-rekeninge, over de middelpunts-kragten en over de wetten der aantrekkinge. Leyden: Jan & Hermanus Verbeek; Translation of Shizuki, Tadao: (1782), 1798 (astronomy), 1800 (Physics), 1798 (circular motions). *Rekishō Shinsko* (曆象新書, New notes on other phenomena). 1-3. Edo.

Kepler, Johannes. 1604. *Ad Vitellionem paralipomena, quibus astronomiae pars optica traditur: potissimum de artificiosa observatione et aestimatione diametrorum deliquiorumq; solis & luane cum exemplis insignium eclipsium. Habes hoc libro, lector, inter alia multa nova, tractatum luculentum de modo visionis, & humorum oculi usu, contra opticos & anatomicos ...* Frankfurt: Claude Marnius & Haeradam Joannis (Valvasor's book).

Kepler, Johannes. 1611. *Dioptrice*. Augsburg: David Franci (Valvasor's book).

Kepler, Johannes. 1619. *Harmonice mundi libri V*. Linz: Gottfried Tampach & Johann Planck (NUK-GS 7921).

Kepler, Johannes. 1627. *Tabulae Rudolphinae, quibus astronomicae scientiae temporum longinquitate collapsae Restauratio continetur; A Phieniceillo Astronomorum Tychone Braheorum ... familia ... primum animo concepta et destinata ... ; tabulas ipsas ... perfecit, absolvit ... traduxit Joannes Keplerus*. Ulmae: Jonas Sauris (J-528 not today in NUK; Stična Cistercians' library from Florjančič's library). 2: 1659; 3: 1667 (Ljubljana bookshop Mayr's offer in 1678, p. 91).

Kepler, Johann. 1984. *Le secret du monde*. Paris: Société d'édition «Les belles lettres».

Kern, Johann Gottlieb. 1772. *Bericht von Bergbau*. Leipzig: Siegfried Leberecht Crusius.

Khell von Khellburg, Joseph S.J. 1751. *Physica ex recentiorum observationibus accommodata. Usibus academicis a Josepho Khel e S.J.* 2 parts. Viennae: Trattner. 2: 1754, 1755. Viennae (KSSKL-V 29; NUK-8206).

Kiauta, Boštjan (Bastian). 2015. Spomini na mladostno "entomologiziranje" v Ljubljani med drugo svetovno vojno in neposredno po njej (1941-

1953). *Erjavecia (Ljubljana)*. Volume and Number 30: 16-32.

Kidrič, France. 1925. Bonomo Peter (keyword). *SBL*. 1: 53-54.

Kidrič, France. 1926. Erberg, Jožef Kalasanc, baron (1771–1843) (keyword). *SBL*. 1/2: 161-165.

Kidrič, France. 1939. *Zoisova korespondenca 1808-1819*. Ljubljana: SAZU.

Kedrov, Fedor Borisovič (Федор Борисович Кедров). 1980. *Ernest Rutherford*. Moscow: Nauka (Science, Knowledge).

Khrilovich, Iosif Benzionovich (Иосиф Бенционович Хрилович). 1992. The eventful life of Fritz Houtermans, *Phys.Today* (1 July 1992) 45/7: 29-37.

Kilby, Jack StClair. July 1976. Invention of the integrated circuit, *IEEE Transactions Electron Devices*, Volume ED-23 No. 7, pp. 648-654.

Kircher, Athanasius, 1650. *Musurgia universalis sive Ars magna consoni et dissoni in X libros digesta... Liber IX Magiam Consoni et Dissoni*, 1-2. Romae: heirs of Francisco Corbelletti (Valvasor's book; Auersperg's book; NUK-M 5337 with the Jesuitical bookplate dated in 1756).

Kircher, Athanasius. 1641. *Magnes sive de Arte Magnetica libri tres Authore P. Athanasio Kirchero...* (*Artis Magnetica*), Romae: sumptibus Hermanni Scheus ex Typographia Ludovic Grignan (Auersperg's book, Brigham Young University Library; NMLJ-K XI 8). Extended reprint: 1654. *Magnes sive de Arte Magnetica...* Rome: Masotti (Valvasor's book).

Kircher, Athanasius. 1657. *Athanasii Kircheri e Soc. Jesu Iter extaticum II Qui et Mundi Subterranei Prodromus dicitur. Quo Geocosmi opificium sive Terrestris Globi Structura, unà cum abditiis in ea constitutis arcanioris Naturae Reconditoriis, per ficti raptus integumentum exponitur ad veritatem. In III Dialogos distinctum (Structura globis terrestris). Ad Serenissimum Leopoldum Ignatium Hungariae, et Bohemiae Regem* (included: Sigismund Siserius,

Epistola ad R. P. Kircherum, in qua hydria sive fodina argenti vivi in Carniola describitur). Romae: Mascardi (Auersperg's book). Reprint: 1659. Turnaviae: Frideric Gall.

Kircher, Athanasius. 1646. *Athanasii Kircheri Fuldensis Bvchonii e Soc. IESU Presbyteri Olim in Herbipolensi, & Avenionensi Societatis IESU Gymnasiis Orientalium linguarum, et Mathesos, nunc huius in Romano Collegio Professoris Ordinarii Ars Magna Lucis et Umbrae, In decem Libros digesta Quibus Admirandae Lucis et Umbrae in mundo, atque adeò universa natura, vires effectusq. uti nova, ita varia nouorum reconditorumq. speciminum exhibitione, ad varios mortalium usus, panduntur*. Romae: Sumptibus Hermanni Scheus. Ex Typographia Ludovici Grignani (Auersperg's book now NUK-8100, bookplate: Wolffg. Engelb. S. R. J. Com: *Ab Auersperg Sup. Cap. Carn: Cat.Inscr. Ao. 1658*). In between the later Jesuitical exlibis: *Bibliotheca Philosophicae Collegio Soc: Jesu Labaci 1697*). Reprint: 1671. ...*Editio altera priori multo auctior*, Amsterdam: Jansson (Valvasor's book).

Kircher, Athanasius. 1650. *Musurgia universalis, sive Ars magna consoni et dissoni in X. libros digesta. Quà Universa Sonorum doctrina, et Philosophia, Musicae que tam theoreticae, quam practicae scientia, summa varietate traditur; admirandae Consoni, et Dissoni in mundo, adeòque Universâ Naturâ vires effectusque, uni nova, ita peregrina variorum speciminum exhibitione ad singulares usus, tum in omnipoene facultate, tum potissimum in Philologiâ, Mathematicâ, Physicâ, Mechanicâ, Medecinâ, Politicâ, Metaphysicâ, Teologiâ, aperiuntur et demonstratur*, Romae: heirs of Francisco Corbelletti (Auersperg's book; NUK-M 5337).

Kircher, Athanasius. 1656. *Itinerarium Extaticum Coeleste quo mundi opificium id est Coelestis expansi, siderumque tam errantium, quam fixorum natura, vires, proiprietates, singulorumque compositio & structura, ab infimo telluris globo usque ad ultima Mundi confinia, per ficti raptus integumentum explorata, nova hipotesi exponitur ad veritatem. Interlocutoribus Cosmiele et Theodidacto (Structura globis Coelestis)*, Romae: Vitalis Mascardi (Auersperg's book: Valvasor's

book; 4^o). Reprint: 1671. Würzburg: Endter bind to: Kircher. 1660. *Iter Extaticum II*. Würzburg: Endter.

Kircher, Athanasius. 1658. *Athanasii Kircheri e Soc. Jesu Scrutinum Physico-Medicum Contagiosae Luis, quae Pestis dicitur. Quo Origo, causae, signa, prognostica Pestis, nec non insolentes malignatis Naturae effectus, qui statis temporibus, caelestium influxuum virtute et efficacia, tum in Elementis; tum in epidemiis hominum animantiumque morbis elucescunt, una cum appropriatis remediorum Autidotis nova doctrina in lucem eruuntur. Ad Alexandrum VII. Pont. Opt. Max.*, Romae: Typis Mascardi (Auersperg's book). Reprint with C. Lange's foreword: 1671. *Scrutinium physico-medicum contagiosae*. Lipsiae: sumptibus haered. Schurerianor & Joh. Fritzschi: typis Johannis Baueri (Ex Bibliotheca Gerbeziana now SKLJ-SK T VI 11 č). Partial Reprints-adaptations: 1739. *De venenis liber physico-medicus. publico commodo recusum: dum per reverend. patrem Urbanum Madcho, e Soc. Jesu, AA.LL & Phil. Doctorem, ejusdemque in Alma ac celeberrima Universitate Graeciensi Professorem Actuaalem, In ejusdem Universitatis Aula Academica, De Re litteraria philosophica benemeriti prima AA. LL. et phil. laurea donarentur*. Graecii: heirs of Widmanstetter (KSSKL-Kranj-1482 (X 72; pages 4+224+8, 8^o) with bookplate: Loci Capucinatorum Crainburgi...Alexij Wazstein 1739; KSSKL-Loka-1484; NUK-GS 11688 from Society of agriculture and useful arts; MINSPT); 1740. *Scrutinium pestis physico-medicum publico commodo recusum. dum per reverend. patrem Urbanum Madcho (Urban Madko (Matko)), e Soc. Jesu, AA.LL. & phil. doctorem, ejusdemque in alma ac celeberrima Universitate Graecensi professorem emeritum, nec non inclytæ facultatis philos. p.t. seniore, & consistorialem, in ejusdem Universitatis aula academica, de re litteraria philosophica benemeriti, suprema philosophiae laurea donarentur*. Graeci: heirs of Widmanstetter (NUK-GS 11813).

Kircher, Athanasius. 1652. *Oedipus Aegyptiacus. Tomus I*, Romae: Vitalis Masscardi. Next part: 1653. *Athanasii Kircheri e Soc. Jesu Oedipus Aegyptiacus. Hoc est Universalis Hieroglyphicae Veterum Doctrinae temporum iniuria abolitae instauratio. Opus ex omni Orientalium doctrina et sapientia conditum, nec non viginti diuersarum linguarum auctoritate stabilitum, Felicibus Auspicijs*

Ferdinandi III Austriaci Sapientissimi et Invictissimi Romanorum Imperatoris semper Augusti è tenebris erutum, Atque Bono Reipublicae Literariae consecratum. Tomus secundus, Romae; Vitalis Masscardi; Next Part: 1654. *Athanasii Kircheri Soc. Jesu Oedipi Aegyptiaci Tomi secundi Pars altera Complectens Sex posteriores Classes. Felicibus Auspicijs Ferdinandi III Caesaris, Tomus III* Romae: Vitalis Masscardi (Auersperg's book, Valvasor's book).

Kircher, Athanasius. 1661. *Athanasii Kircheri Soc. Jesu Diatribe. De prodigiosis Crucibus, quae tam supra vestes hominum, quam res alias non pridem post ultimum uncendium Vesuvij Motis Neapoli comparuerunt*, Romae: Vitali Mascardi, Blasius Deversin (Auersperg's book with bookplate of 1663, Brigham Young University Library; California State Library-Sutro; Stanford University Library; Boston College; Harvard University Houghton Library; Cambridge University; Welcome Institute for the History of Medicine, RCON (EMW)). Reprint: Schott. 1672. *Joco-seriorum naturae et artis sive magiae naturalis centuriae tres. Das ist dreyhundert nutz und luftige Sätze allerhand merrckwürdigen Stücke von Schrompf und Ernst genomen aus der Kunst und Natur oder natürrigser Magia. Aus R. P. Athanasi Kircher S.J. Diatriba...*, Franckfurt am Main, p. 307 (bookplate: DN Francisci Benedec de Netztin A^o 1699 28. Martis now NUK-8207).

Kircher, Athanasius. 1664-1665. *Mundus Subterraneus, In XII Libros digestus: quo divinum subterrestris mundi opificium, mira ergasteriorum naturæ in eo distributio, verbo [pantamorphon] protei regnum, universæ denique naturæ majestas & divitiæ summa rerum varietate exponuntur: abditorum effectuum causæ acri indagine inquisitæ demonstrantur: cognitæ per artis & naturæ conjugium ad humanæ vitæ necessarium usum vario experimentorum apparatu, necnon novo modo, & ratione applicantur*, Amsterdam: Joann Jansson & Elizeum Weyerstrat. Third edition: 1678. Amsterdam: Joann Jansson (Ljubljana Philosophical Faculty, library of classical philology (Klasična filologija)). Reprinted partially as: 1741. *Tractatus de animalibus subterraneis et insectis, ex operis R.P. Athanasii Kircheri, S.J. excerptus, et laureatis honoribus perillustris domini Joannis Laurentii*

Dragancich, Sac. rom. imp. Nobilis de Drachenfeld, dum in Alma ac Celeberrima Universitate Graecensi primâ AA. LL. et philosophiae Laureâ ornaretur. Promotore R.P. Ignatio Schreiner, è S.J. AA. LL. et Phil. Doctore, ejusdémque in physicis professore ordinario, a neo-baccalaureis condiscipillis oblatus. Anno M,CC,XLI, mense majo die 30. Græcii: Typis Haeredum Widmanstadii (Widmanstetter) (MINSPT).

Kircher, Athanasius. 1667. *Athanasii Kircheri e Soc Jesu, China monumentis: qua sacris qua profanis, nec non variâ naturae & artis spectacularis, aliarumque rerum memorabilium argumentis illustrata, auspiciis Leopoldi Primi Roman. Imper. (China illustrata). Amstelodami: Joann Jansson (Janszon) a Waesberge & Elizeum Weyerstraet (Auersperg's book). Modified reprint: 1672. Monumenti Sinici, quod anno domini [1625]. terris in ipsâ Chinâ erutum: seculo verò Octavo Sinicè, ac partim Syriacè, in Saxo perscriptum esse, adeoque dogmatum & ritum Romanae ecclesiae ... antiquitatem magnoperè confirmare perhibetur lectio seu phrasis, versio seu metaphrasis, translatio seu paraphrasis, planè uti Athanasius Kircherus in China sua illustrata. Berolini: Ex officina, Rungiana (ed. Andreas Müller).*

Kircher, Athanasius. 1679. *Turris Babel, sive Archontologia*, Amstelodami: Joann Jansson (Janszon) a Waesberge (SKLJ-SK V VIII 7; Valvasor's book).

Kircher, Athanasius. 1663. *Athanasii Kircheri e Soc Jesu Polygraphia nova et universalis, ex combinatoria arte detecta. Quà Quiuis etiam Linguarum quantumvis imperitus triplici methodo, Prima, Vera et reali sine ulla latentis Arcani suspicione, manifestè; Secunda, per Technologiam quandam artificiosè dispositam. Tertia, per Stenographiam impenetrabili scribendi genere adornatam, unius vernaculae linguae subsidio, omnibus populi set linguis clam, apertè; obscurè, et dilucidè scribere et respondere posse docetur, et demonstratur. In III. Syntagmata distributa In Principum gratiam ac recreationem inventa et in lucem edita. Felicibus Auspiciis Leopoldi Rom. Imperat. Semper Augusti, Romae: ex Typofraphia Varesij (Auersperg's book, folio; 148 & 33 pages). Reprint: 1680. Amstelodami (folio).*

Kircher, Athanasius. 1667. *Athanasius Kircheri e Soc Jesu, Magneticum Naturae regnum, sive disceptatio Physiologica De triplici in Naturam rerum Magnete, iuxta triplicem eiusdem Naturae gradum digesto Inanimato Animato Sensitivo Quae Occultae prodigiosarum quarundam motionem vires et proprietates, quae in triplici Naturae Oeconomia nonnullus in corporibus noviter detectis observantur, in apertam lucem eruuntur, et luculentis argumentis, experientia duce, demonstratur. Ad Inclytum, et Eximium Virum Alexandrum Fabianum Novi orbis Indigenam, Romae: Ignatii de Lazaris (Valvasor's book, 4^o; 136 pages).*

Kiss, László. 26 June 2011. Orvosok a levegőben 1811-ben - Menner és Kraskovics doktorok légi útja Pesten és Pozsonyban (Physicians in the sky in 1811 – the flight of Menner and Kraskovics MDs in Pest and Pressburg: Altitude Sickness, History, Aviation, Physicians, Air). *Orvosi hetilap* (Akadémiai Kiadó). 152/26: 1052-1055.

Klein, Felix. 1926. *Vorlesungen über die Entwicklung der Mathematik im 19. Jahrhundert*. Berlin: Springer. Russian translation: 1989. Moskva: Nauka.

Klein, Franz (editor). 1885. *Bericht über die internationale elektrische Ausstellung Wien 1883, Unter mitwirkung hervorragender fachmänner, herausgegeben von Niederösterreichischen Gewerbe-Vereine*. Wien: Verlag von L. W. Siedel & Sohn.

Kleinert, Andreas. January-March 1993. Ferdinand Braun et les débuts de la TSF an Alemagne. *RHS*. 46/1: 59-72.

Klekler, Karl. 1869. Die Grundzüge der mechanischen Wärmetheorie. *Sechter Jahresbericht über die k. k. Oberrealschule in der Militärgrenz-Communität Pančova*. Pancsova (Pančevo): Anton Siebenhaar. 3–18.

Klemenčič, Ignac. 1881. O Fotofonu (About the photophone). *Ljubljanski Zvon (Ljubljana Bell)*. 1/1: 52-55, 1/2: 122-124.

Kmecl, Matjaž. 2005. Kulturna podoba J. V. Valvasorja za Slovence, *Kras*, 70: 8–11.

Knaflič, Josip; Ante Gaber; Milan Zadnek; Ivan Albreht (eds. of anonymous publication). 1936. Genij inženjer Nikola Tesla: zanimivosti o njegovem značaju, delu in življenju. *Glas Naroda*. Ljubljana: Narodna prosveta, 29 May 1936, 2/121: 5.

Knobloch, Eberhard. 2003. Otto von Guericke und die Kosmologie im 17. Jahrhundert. *Berichte zur Wissenschaftsgeschichte*. 26: 237-250.

Knobloch, Gustav. 1884. Ueber Transformation in der orthogonalen Axonometrie. *XIV. Jahresbericht der k. k. (Kaiserlich-Königliche) Staats-Oberrealschule in Marburg Veröffentlicht von der Direction am Schlüsse des Studienjahres 1884*. Maribor: Edvard Janšič (Marburg: Eduard Janschitz), pp. 3-12 with additional two plates of pictures on the end.

Knod, Gustav Carl. 1976, *Die alten Matrikeln der Universität Strassburg*, 1-3, Nendeln in Liechtenstein: Kraus.

Knoll, Max, Ruska, Ernst. 1932. Beitrag zur geometrischen Elektronenoptik I. *Ann. Phys.* 12 (404/5): 607-661 submitted 10 September 1931.

Knoll, Paul W. 2016. "A Pearl of Powerful Learning": *The University of Cracow in the Fifteenth Century*. Leiden/Boston: Brill.

Knudsen, Martin. 1910. Thermical Molekulardruck der Gase in Röhren und pörosen Körpern. *Ann. Phys.* (4) 31: 633-640.

Knudsen, Martin. 1910. Et absolut Manometer. *Udsnit af Oversigt over det kgl. danske Videnskabernes Selskabs Forhandling* (Excerpt of *Overview of the royal Danish Scientific Society's Debates*). Copenhagen. Translation: Ein absolutes Manometer. *Ann. Phys.* 337/9 (4) 32: 809-842.

Knudsen, Martin. 1912. La théorie cinétique et les propriétés expérimentales des gaz parfaits. *La théorie du rayonnement et les quanta. Reports and discussions of the Reunion at Brussels, 30 October and 3 November 1911*, Paris: Gauthier-Villars.

Kobav, Andrej. 1643/1644. *Vindiciae Astronomicae et ethicae pro Dionysio Exiguo, abbate Romano, contra eximios chronographos praeterpropter summos imos aeram vulgarem usurpantes seu nato, motuo redivivoque Iesu homini Deo de incarnationis passionisque anno MDCXXXIII. Mense_ Die_ vota dissertatio*. Viennae: Greg. Gelbhaar.

Kobencl (Cobenzl) & Ermens, Joseph. 1771. *Catalogue des livres, en toutes sortes de facultez et langues, de feu S. E. le comte de Cobenzl, Chevalier de l'Ordre de la Toison d'Or, Grand Croix de l'Ordre de Saint-Etienne, Ministre Plénipotentiaire de S.M. l'Impératrice Douairière et Reine Apostolique pour la Gouvernement des Pais-Bas, etc, etc, disposé par ordre des matieres & avec quelques notes litteraires*, Bruxelles: Veminchk.

Kobencl (Cobenzl); Paterson, Samuel. 1772. *A catalogue of a choice collection of books, antient and modern, in various languages and sciences, and in neat condition, lately made in the Netherlands: ... many of which were selected from the libraries of their excellencies the late Count Cobenzl, Prime Minister in the Austrian Netherlands; the Marquis Fuente Fuerte, the Spanish Ambassador to the States-General, De Heer de Buys as the secretary of Estates General of Holland and West Friesland, Philip Douw, M. D. of Middelburg & tc...* London.

Kobencl (patron); Macquereau de Valenciennes, Robert; Paquot, Jean-Noël (ed.). 1765. *Histoire générale de l'Europe depuis la naissance de Charles-Quint jusq'au cinq juin MDXXVII*, Imprimerie académique, Leuven. Continuation: 1841. *Histoire générale de l'Europe Durant les années MDXXVII, XXVIII, XXIX*. Paris.

Kohler, Alfred. 2011. Humanizem v srednji Evropi. *Tu felix Europa* (ed. Rajšp, Vincenc; Bister, Feliks J.; Polzer, Miroslav). Vienna: Slovenski znanstveni inštitut/Ljubljana: ZRC SAZU. 17–24.

Kohlschütter, Ernst Arnold; Walter Sydney Adams. 1912. Observations of the spectrum of Nova Geminorum no. 2. *Astrophysical journal*, vol. 36. Reprint: 1912. *Contributions from the Mount Wilson solar observatory*. No. 62. Washington: The Carnegie institution.

Kokalj, M.J. 1878. Telefon ali Daljnoglasnik (Telephone or Distance Speech), *Zora*, 7/3: 35-40.

Kokole, Jože. 1969. *Bibliografija doktorskih disertacij univerze in drugih visokošolskih in znanstvenih ustanov v Ljubljani 1920–1968*. Ljubljana: University.

Kokole, Metoda. 2004. Academia Philcarmonicorum Labacensum v evropskem okviru. *Academia Philcarmonicorum Labacensum 1701–2001* (ed. Klemenčič, Ivan), Ljubljana: ZRC SAZU, 29-56.

Koláček, František (Brno). 1882. O elektrometrech (on electrometers). *Časopis pro pěstování matematiky a fysiky* of Prague based *Jednota českých matematiků*. 11/4: 251-265.

Kolanović, Josip; Šumrada, Janez. 2005. *Napoleon in njegova uprava na vzhodnem Jadranu in na ozemlju vzhodnih Alp 1806-1814*. Zagreb: Hrvatski državni arhiv (Croatian State archive).

Koller, Marian OSB. 1841. *Ueber den Gang der Wärme in Oesterreich ob der Enns eine in der 6ten General-Versammlung der Mitglieder d. Franciscus-Carolinum gelesene Abhandlung*. Linz: Eurich, 31 pages.

Koller, Marian OSB. 1843. Resultate zehnjähriger auf der Sternwarte zu Kremsmünster angestellten Beobachtungen über die Feuchtigkeitsverhältnisse unserer Atmosphäre (Humidity conditions in the air). *Jahrbuch des Oberösterreichischen Musealvereines (Linz)*. 7: 154 - 211. Shortened reprinted versions: 1843. *Ber. Deutch. Naturfors. Vers. (Amtlicher Bericht über die Versammlung Deutscher Naturforscher und Ärzte)* 251-254; 1844. *Ann. Met.* (Dr. J. Lamont's *Annalen für Meteorologie und Erdmagnetismus und verwandte Gegenstände* in Munich, edited by Johann August Grunert, Prof. Marian Koller of Kremsmünster, Karl Kreil of Prague, Johann Lamont, Wilhelm Heinrich Theodor Plieninger, Adolphe Quetelet, meteorologist-astronomer Phillipp Stieffel of Karlsruhe). 10: 164-171.

Koller, Marian OSB. 1847. Schreiben des Herrn Koller an den Herausgeber (= Heinrich Christian

Schumacher). Kremsmünster 1846. Juli 4. Resultate aus den meteorologischen Beobachtungen zu Kremsmünster im Jahre 1845. *Astronomischen Nachrichten* (Altona: Hammerich - und Lesser'schen Buchdruckerei). 25/593: 263-272.

Koller, Marian OSB. May 1850. Ueber die Berechnung der periodischen Naturerscheinungen, *Denkschriften der Kaiserlichen Akademie der Wissenschaften. Mathematisch-naturwissenschaftliche Klasse*. In *Vienna* (Wien: K.K. Hof- und Staatsdruckerei), 1: 54-74 (on 37 cm leaves, read on the meeting 13 April 1848 after he became a founding full member of Academy on 26 January 1848).

Koller, Marian OSB. 1863. Ueber das Passage-Instrument. *Verhandlungen des naturforschenden Vereins in Brünn (Jahreshefte*, Brno: Gastl) volume 1, 38 pages.

Koller, Marian OSB. 1864. Zur Theorie des August'schen Heliostaten. *Verhandlungen des naturforschenden Vereins in Brünn* (Brno: Gastl) volume 2, 14 pages.

Kołos, Anna. 2017. Battle of the „glass pipe”. Struggle between the „old” and „new” in the debate around experiments with vacuum dating to 1647 (Batalia „szklanej rury”. Współzawodnictwo „starego” i „nowego” w debacie wokół doświadczeń z próżnią z 1647 roku). *Wydawnictwo Poznańskie Studia Polonistyczne*, 31: 167-190.

Konen, Heinrich. 1908. Fluorescenz. In: Kayser. *Handbuch der Spectroscopie*. Final Paragraph on pages 839-1214.

Kopatkin, Viktor, S.J. 1934. Gabrijel Gruber S.J. in njegov prekop. *Kronika*. 1/1: 8-14.

Kopp, Hermann. 1886. *Die Alchemie in älterer und neuerer Zeit*. Heidelberg: Carl Winters.

Korade, Mijo. 1990/1991. Filozofska i prirodnoznanstvena djela profesora filozofije u 18. stoljeću. *Vrela i prinosi*. 18: 21-67.

Korade, Mijo. 1998. Prilog o filozofiji hrvatskih isusovaca u 17. stoljeću - rukopis Fizike Leonarda

Bagnija iz godine 1628. *Prilozi za istraživanje hrvatske filozofske baštine*, 24/1-2 (47-48): 131-144.

Kordiš, Ivan. March 2001. Friderik II. Celjski in Veronika Deseniška. *Kočevski Kam.* 1/1, pp. 7-8.

Korošec, Branko. 1967. Beseda dve o Steinbergovem in drugih opisih Cerkniškega jezera, *Kronika*. Ljubljana, 15: 11–22.

Van der Korst, Jan Klaas. 2003. *Een doktet van formaat, Gerard van Swieten, lijfarts van keizerin Maria Theresia*. Amsterdam: Uitgeverij Bert Bakker / Houten by Utrecht: Bohn Stafleu van Loghem.

Kos, Dušan. 1991. *Urbarji za Belo krajino in Žumberk (Land registers for Bela krajina and Žumberk)*. Ljubljana: SAZU.

Kos, Dušan. 2019. Mali veliki človek pred kraljico: državniške zamisli in komunikacija državnega uradnika z vladarjem in visoko politiko v času reform v habsburških deželah sredi 18. stoletja. *Zgodovina za vse: vse za zgodovino*. 26/1: 5-17.

Kössler, Dragutin (Koessler, Karl). 1873. Noviji pokusi o provodu topline u krutinah (New experiments about the translation of Heat in solids). *Program kraljevske više (višje) gimnazije na Rēci (Rijeka, Fiume) koncem školske godine 1872/3 (Programm des k.k. Obergymnasiums in Fiume: veröffentlicht am Schlusse des Schuljahres 1872/73. 23. Jahrgang (Yearly Program of Rijeka (Fiume) Grammar School in 1872/73)*. Zagreb. Pp 3-30.

Kössler, Dragutin (Koessler, Karl). 1874. Alpinski ledenjaci. *Godišnje izvešće Kraljevske više realke u Zagrebu koncem školske godine 1873/74 (Izveštaj zagrebačke realke god. 1873-4)*. Zagreb: Narodna tiskarnica Ljudevita Gaja.

Košir, Matevž. 2002. Brat Vega, protozidar. *Anthology za zgodovino naravoslovja in tehnike* 15–16: pp. 75–111.

Kovač Artemis, Tita. 2005. *Kako je nastala knjiga o deželi Kranjski in zapiski in viri ob njej in zanjo z doživetji samega gospoda barona Janeza Vajkarda Valvasorja, shranjenimi in z opombami opremljenimi od njegovega kopista in pisarja Janeza*

Lenarta, pregledani in objavljeni od gospe Mire Ceti (about Valvasor's book), Ljubljana: self-publishing.

Kovačević, Zoran L. 2014. *Susret i sukob sa naukom*. Novi Sad: Akademsko Knjiga (Academic books)/Srpska Akademija nauka i umetnosti.

Kovačič, Lojze. 1998. Rektorji jezuitskega kolegija v Ljubljani (9 August 1597–29 September 1773). In: *Jezuitski kolegij v Ljubljani (Jesuitical Colege in Ljubljana: Anthology)* (ed. Rajšp, Vincenc; Juhant, Janez). Ljubljana: Zgodovinski inštitut Milka Kosa ZRC SAZU, Inštitut za zgodovino Cerkev Teološke fakultete v Ljubljani in Provincialat slovenske province Družbe Jezusove, pp. 49-76.

Kovič, Kajetan. 1974. *Literatura. Hezoid*. Ljubljana: Mladinska Knjiga (Juvenile books).

Koyré, Alexandre. 1968. *Metaphysics and Measurement*. London: Chapman & Hall.

Kral, Johann. 1872. *Der Morse-Telegraph. Ein Handbuch zum Gebrauche für Telegraphen-Aspiranten und Beamte*. Maribor: self-publishing (Selbstverlage, samozaložba).

Kralj, Analina; Kralj, Davorin. 2015. *Franz Swaty in umetnost brušenja v Mariboru*. Maribor: Pivec.

Kramer, Bernhard. 1997. Der Transistor wird fünfzig. *Phys. Bl. (Physikalische Blätter)* (ed. Ernst Brüche). 53/12: 1203-1206.

Kranjc-Vrečko, Fanika. 2002. Splošna prepisovalna načela. In: *Zbrana dela Primoža Trubarja I*. Ljubljana: Rokus. 542-568.

Kraškovič, Gregor; Menner, Johann G. 14 December 1814. Relation über die von Physikern Kraskovitz und Männer zu Wien am 20. November 1814 Nachmittags 4 Uhr veranstaltete 6te Luftfahrt (Report about sixth flight of the physicians Kraškovič and Männer designed above Vienna on November 20, 1814 at 4 PM). *Laibacher Wochenblatt zum Nutzen und Vergnügen*, supplement of *Laibacher Zeitung* (Ljubljana: Ignaz Alois Edler von Kleinmayr). Reprint: 30 August 1879. *Laibacher Tagblatt* as addition of *Laibacher Zeitung*.

- Kraškovič, Gregor; Menner, Johann G. 1811. Lufthart des dr. Kraskowitz in Pressburg (Report on Bratislava flight). *Vaterländische Blätter*. Wien. 2 October 1811, pp. 475-476.
- Kraškovič, Gregor; Menner, Johann G. (Ivan Nepomuk Menner, Joann Maenner, Manner, Männer); Pr. (= Johann Joseph Prechtl as commentator). 1810. IV. Bemerkungen über die am 13. August im Prater ausgeführten aerostatischen Experimente (Report about the failed flight above the Viennese Prater, Poročilo o ponesrečenem neobljudenem poletu nad Dunajskim Praterjem). *Vaterländische Blätter für den österreichischen Kaiserstaat* (ed. Christian Aspalter und Anton Tantner). Wien. 24 August 1810, pp. 287-289.
- Kraškovič, Matija Gregor (Matthew Gregorius Kraskovitz). Sent February 1, 1805, printed May 1, 1805. Kraskovitz', Dr. Letter to the Royal Jennerian Society (Report on vaccination in Varaždin). *The Medical and Physical Journal*. London: W. Thorne for Richard Philipps (ed. T. Badley, R. Batty, A.A. Noehden), 13 (75)/1 (published in January-June 1805 number): 479.
- Kraškovič, Matija Gregor. 1810. *Darstellung der vorzüglichen Versuche die Luft zu Durchschiffen, und Blicke, auf ihren Zweck, Werth, und Vortheile. Von M. G. Kraskovitz Doctor der Heilkunde, ehemahligen Phisicker zu Varasdin, und gegenwärtig ausübendem Arzte zu Wien*. Wien: Schrämblisch.
- Križanič, France; Strnad, Janez. 1979. Sedemdesetletnica profesorja Antona Peterlina. *Obzornik za matematiko in fiziko* (Ljubljana). 26: 47-49.
- Kroflič, Marjan; Dimic, Viktor. 1989. *Osnovni podatki o Institutu »Jožef Stefan«*. Ljubljana: IJS.
- Krones, Franz. 1886. *Geschichte der Karl-Franzes Universität*. Graz: Karl Franzes Universität.
- Krönig, August Karl. 1856. Grundzüge einer Theorie der Gase. *Ann. Phys.* 99/33 (series 2): 315-322. Separate print: 1856. Berlin: A. W. Hayn.
- Krönig, August Karl. 1864. Über die Concentration der Luftarten. *Ann. Phys.* (series 2) 123: 299-332.
- Krstić, Djordj. 2002. *Mileva & Albert Einstein ljubezen in skupno delo*. Didakta, Radovljica. Translation: Krstić, Djordj. 2004. *Mileva & Albert Einstein Their Love and Scientific Collaboration*. Radovljica: Didakta (including Južnič's: Answer to Planck – Written in Mileva Einstein's Handwriting. Pp. 236-246). Serbian translation: 2005. Novi Sad: Srbska Matica (including Južnič's: *Odgovor Plancku*).
- Kudrjavcev, Pavel Stepanovič (ed. Arkadij Klimentovič Timirjazev). 1948. *Istorija fiziki / Tom I, Ot antičnoj fiziki do Mendeleeva (История физики. Том I. От античной физики до Менделеева, History of Physics I)*. Moskva: Gosud. Učebno-Pedag. Izd. Ministerstva Prosveščeniija RSFSR (Učpedgiz).
- Kudrjavcev, Pavel Stepanovič. 1955/1956. *Istorija fiziki / Tom II (История физики. Т. 2. От Менделеева до открытия квант (1870—1900), History of Physics II)*. Moskva: Gosud. Učebno-Pedag. Izd. Ministerstva Prosveščeniija RSFSR (Učpedgiz).
- Kudrjavcev, Pavel Stepanovič. 1971. *Istorija fiziki / Tom III (История физики. Том 3. От открытия квант до создания квантовой механики (1900—1925), History of Physics III)*. Moskva: Gosud. Učebno-Pedag. Izd. Ministerstva Prosveščeniija RSFSR (Učpedgiz).
- Kuhn, Thomas Samuel. 1958. The Caloric Theory of Adiabatic Compression. *Isis*. 49: 132-140.
- Kuhn, Thomas Samuel. 1996. *The Structure of Scientific Revolution*. Chicago: University of Chicago. 3rd edition.
- Kuhn, Thomas Samuel. 2000. *The road since structure: philosophical essays, 1970-1993, with an autobiographical interview* (ed. Conant, James Bryant; Haugeland, John). University of Chicago Press.
- Kulišić, Kosta (Kosto). 1931. Sedamdesetpetogodišnjica Nikole Tesle – Buran

studentski život i prva stvaranja. *Politika (Beograd)* 19 July 1931, page 10 with a picture. Simultaneous edition: 1931. Sedamdesetpetogodišnjica Nikole Tesle, *American (Amerikanski) Srbobran*, Pittsburgh, August 26-27.

Kulišić, Kosta. 1936. *Nikola Tesla. Njegov djački život i naučni rad [u kratkim crtama]*. Sarajevo: Bosanska Pošta.

Kundegraber, Marija. 1991. Die Deutsche Sprachinsel Gottschee im 19. Jahrhundert. *Etnolog. Nova vrsta* (Ljubljana: Slovene Ethnographic Museum). 1 (52)/1: 82–120.

Kundt, August Adolf; Warburg, Emil Gabriel. 1875. Ueber Reibung und Wärmeleitung verdünnter Gase. *Ann. Phys.* 155: 337-366, 525-550; 156: 177-211.

Kundt, August Adolf. 1876. Apparat zur Demonstration der Reibung in einem sehr verdünnten Gas (Vacuum). *Ann. Phys.* 234/158: 568-572.

Kundt, August Adolf. 1878. Ueber den Einfluss des Lösungsmittels auf die Absorptionsspectra gelöster absorbierender Medien. *Ann. Phys.* 240/5: 34-54.

Kundt, August Adolf. 1886. Ueber Doppelbrechung des Lichtes in Metallschichten, welche durch Zerstäuben einer Kathode hergestellt sind. *Ann. Phys.* 27: 60-70.

Kundt, August Adolf. 1888. Ueber die Brechungsexponenten der Metalle. *Ann. Phys.* 34: 473-474.

Kunic, Maria married von Love (Kunitz, Cunitz. 1659, 1654. *Urania propitae, sive Tabulae Astronomicae mirè faciles Newe... Astronomische Tabellen*. Byczyn: Oels Johann Seyffert. 144 pages, 286 illustrations (Mayr's sales catalogue in Ljubljana in 1678).

Kunckel von Löwenstern, Johann. 1716. *Johann Kunckels von Löwenstern... Collegium physico-chymicum experimentale, oder Laboratorium chymicum : in welchem deutlich und gründlich von den wahren principiis in der Natur und denen gewürckten Dingen, sowol über als in der Erden, alls Vegetabilien, Animalien, Mineralien, Metallen...*

nebst der Transmutation und Verbesserung der Metallen, gehandelt wird,... nunmehr mit einem vollständigen Register und Vorrede herausgegeben. Hamburg und Leipzig: Samuel Heyls (SKLJ); Reprint: 1738. Hamburg: bey Gottfried Richter (Ex libris Ernesti Freyer... Boemi...: now NUK-22233; NMLJ-K 7208).

Kunckel von Löwenstern, Johann. 1721. *Johann Kunckel von Löwensterns Königl. Schwedischen Berg-Raths und der Kayserl. Leopold. Societät Mitglieds, d. Hermes III. V. Curiose Chymische Tractätlein: als: I. Chymische Anmerckungen... II. Nützliche Observationes von den Fixen und flüchtigen Saltzen, Auro und Argento portabili, Spiritu mundi und dergleichen, wie auch von den Farben und Geruch der Metallen... III. Epistola, contra Spiritum Vini sine Acido. IV. De Phosphoro Mirabili ; dessen leuchtenden Wunder-Pilulen; sampt einem Discurs vom Nitro. V. Probier-Stein, de Acido & Urinoso, Sale Calido & Frigido ; contra Herrn D. Voigts Spir. Vini Vindicatum ; Wobey zugleich angehänget wird: Christoph Brummets Tractätlein vom Blut der Natur. Nebst einer Vorrede: De doctis & nobilibus Empiricis: D. Iohannis Philippi Burggravii.* Frankfurt; Leipzig: Wolfgang Christ. Multz (Ex libris Ernesti Freyer now NUK-GS 22212; Valvasor had II, IV and V part of those).

Kurelac, Miroslav. 1971. *Bibliographia metrologiae historicae: brevis et imperfecta / [1]: Coll. et digessit Miroslav Kurelac. Sociu operis et red. ed. Zlatko Herkov. Scientiae metrologicae instrumentum occasione Consultationum metrologorum ... habitatum ed. Zagrabiae: Inst. histor. Acad. scient. et artium Slavorum Meridionalium (Zagreb: JAZU).*

Kuret, Primož. 2001. *Mahler in Laibach, Ljubljana 1881–1882.* Wien: Böhlau.

Kurylo, Friedrich, Susskind, Charles. 1981. Ferdinand Braun. *A Life of the Nobel Prize and Inventor of the Cathode-Ray Oscilloscope.* Cambridge, Mass.: MIT.

Kuznecov, Boris Grigorievich (Kouznetsov, Борис Григорьевич Кузнецов). 1964. *Galileo Galilei (Галилео Галилей)*, Moskva: Nauka.

- Laaz, Johannes from Laaz; Johannes Trithemius. 1611. *Tractatus de secretissimo antiquorum philosophorum arcano: quo non solum omnes aegritudines totius corporis humani mirabiliter sanantur, verum et immonda ac leprosa corpora metallorum in perfectum lunificum et solifium transmutantur, in gratiam filiorum hermeticae doctrinae nunc primum in lucem editus, autore philosopho anonymo. - Tractatus II, de lapide philosophico Joannis Lasniori, Bohoemi... nunc primum in gratiam studiosae juventutis in lucem editus ab autore anonymo. Tractatus III, chemicus nobilis Joannis Trithemii Abbatis Spanheimensis ... ab quodam autore anonymo ... editus (Tractatus II de lapide philosophico/ Tractatus aureus de lapide philosophorum)*. Leipzig. Laaz' booklet was included in anthology: Joannes de Lasnoro. 1602. *Tractatus aureus de Lapide Philosophorum*. In: Zetzner, Lazarius (ed.). *Theatrum chemicum, praecipuus selectorum auctorum tractatus de chemia et lapidis philosophici antiquitate, veritate, iure, praestantia et operationibus, continens... Volumes I-IV*. (Ober)Ursel: Zetzner. Reprint: 1613. Strasbourg: Zetzner, 4: 579-584.
- Lacoste, Paul-François. 1803. *Observations sur les Volcans de l'Auvergne suivies de notes sur divers objects, Recueillies dans une course minéralogique faite l'année dernière an 10 (1802)*. Clermont-Ferrand: veuve Delcros et Fils & chez Granier et Froin (Zois' book now NUK-8377).
- Lacroix, Sylvester François. 1801. *Traité élémentaire de calcul différentiel et de calcul integral*. Paris. Reprints: 1806 (NUK-4301); 1810; 1895.
- Lačen Benedičič, Irena. 1999. Pridobivanje železa v jeseniških plavžih. *Kronika*. 47/1-2: 73-88.
- Lafferty, James M. 1998. *Foundations of vacuum science and technology*. John Wiley & Sons, Inc.
- Lagalla, Giulio Cesare. 1612. *De phoenomenis in orbe lunae novi telescopii usus a Gallileo Gallileo nunc iterum suscitatis physica disputatio: necnon de luce, et lumine altera disputatio*. Venetiis: Balionus.
- Lagerwall, Sven Torbjörn. 1999. *Ferroelectric and Antiferroelectric Liquid Crystals*. Weinheim: Wiley-VCH.
- Laguzzi, Alessandro. 2010. Carlo Barletti nella Milano delle riforme (1768–1772). *URBS*, Anno XXIII number 2 (June 2010): pp. 100–109.
- Laimbeckhoven, Godefridus. 1740. *Neue umstandliche Reiss-Beschreibung R. P. Godefridi Laimbeckhoven der Gesellschaft Jesu von Wienn nach China abgeschickten Missionarii, darinnen diesen ungemein beschwerlich u. gefährliche Schiffart von Genua bis Macao mit beigemengten vielen gar lehrreichen astronomisch und geographischen Anmerkungen beschrieben, und auf vier Weriangen ihrer Annehmlichkeit halber samt zwei von dem Authore selbst auf eigenen Augenschein fleissigst gefertigten Wasser und Landkarten zum Druck befördert worden*. Wien: Gregor Kurtzböck. Reprint: 1748. *Neue Welt-Bott IV (Joseph Stöcklein's Allerhand So Lehr- als Geistreiche Brieff, Schrifften Und Reise-Beschreibungen, Welche von denen Missionariis Der Gesellschaft Jesu Aus Beyden Indien, Und anderen Uber Meer gelegenen Ländern, Meistentheils von A. 1730. bis 1740. in Europa angelanget seynd Tomus IV, Erste Halbscheid Von dem XXV. bis XXVIII. Theil)*, Wien: Leopold Johann Kaliwoda & Johann Joseph Pentz, part 28, No. 555 (ed. Peter Probst, SJ, Wien 1748): pp. 64-134; No. 590 (Wien 1755): pp. 99-115; *Tomus (volume) V* No. 689 (letter mailed to Erasmus Frölich on 18 July 1746, published in Vienna in 1758): p. 26.
- Lalande, Joseph Jérôme Lefrançois de. 1769. *Voyage en l'Italie (Z)*. Reprint: 1786. *Voyage en l'Italie, contenant l'histoire & les anecdotes les plus singulieres de l'Italie, & sa description; les usages, le gouvernement, le commerce, la littérature, les arts, l'histoire naturelle, & les antiquités; avec des jugemens sur les ouvrages de peinture, sculpture & architecture, & les plans de toutes les grandes villes d'Italie*. 8th part. Paris: Veuve Desaint.
- Lalangue, Joannis Baptist (Ivan Krstitelj, Jean Baptiste). 1777. *Brevis institutio de re obstetricia; illiti kratek navuk od mestri pupkorezne*. Zagreb: Ivan (Johan) Thomas von Trattnern.
- Lalangue, Joannis Baptist (Ivan Krstitelj, Jean Baptiste). 1779. *Joannis Baptistae Lalangue medicinae doctoris artis obstetriciae magistri...*

Tractatus de aquis medicatis regnorum Croatiae et Slavoniae &c. &c., illiti, Izpizavanye vrachtvenih vod Horvatzkoga y Slavonzkoga orzsaga: y od nachina nye vsivati za potrebochu lyudih. Translated from Latin into Croatian by Eugen Klimpacher. Zagreb: Ivan (Johan) Thomas von Trattner (noted in Krašković's legacy inventory in Dubrovnik).

Lambrozzi, Enzo. 1994. Casting from the Beginning up to Present-Day Technology. *Ceramic Engineering and Science Proceedings*. 15/1. 93-94.

Lamy, Bernard. 1680. *Elémens de mathématiques, ou le Traité de la grandeur en général, comprend l'arithmetique, l'algèbre, et l'analyse et les principes de toutes les sciences qui ont la grandeur pour objet... par le R. P. Bernard Lamy.* Paris/Amsterdam; Reprints: 1682... 2e édition revue et augmentée, Paris: widow Delaulne; 1731. Paris: Pierre Witte.

Lana, Francesco Tertio (Terzi) de. 1670. *Prodomo overo saggio di alcune invenzioni (ouero saggio di alcune inuentioni) nuove premesso all'Arte Maestra.* Brescia: Rizzardi (Auersperg's book; Jurij Andrej Triller count Trilek's book in Ribnica castle; Hallerstein's book in Beijing).

Lana, Francesco Tertio (Terzi) de. 1684, 1686, 1692. *Magisterium Naturae et Artis. Opus Physico-Mathematicum.* I-III. Brescia: Johan Maria Ricciardi 1684, 1686/ Parma: Ricciardi 1692 (W-1411 now NUK-8461 with a bookplate in 3rd book: "S.J. Labacii 1752"; SKLJ-T VII 14-16/r; V had first two parts). Partial reprints: 1743. *Artificia Physica selecta ex Tomo III-io Magisterii naturae et artis Franc. De Lanis S.J. Honoribus etc. Inscripta.* Graeci: Widmastatten (W-1529 now NUK-8291); 1744. *Tractatus de motionibus magneticis ex operibus R.P.F. Tertii de Lanis excerptus, et laureatis honoribus J.C. de Cerroni provincialis Styriae... Antonio Vorster... Graeci: Widmastatten (MINSPT- F I 629); 1745. Tractatus de motionibus magneticis ex operis R.P. Francisci Tertii de Lanis S. J. excerptus, et laureatis honoribus perillustrum, reverendorum, religiosorum, praenobilium, nobilium, ac eruditorum dominorum dominorum, cum in Alma ac Celeberrima Universitate Graecensi suprema AA.LL. et philosophiae laurea insignirentur promotore R.P. Antonio Vorster, et Societate Jesu,*

AA.LL. et philos. doctore, ejusdemque professore emerito, nec non Inclutae Facultatis philosophicae p.t. Seniore. A philosophis condiscipulis inscriptus. Anno Salutis M.DCC.XLV. mense julio die. Graeci: Widmastatten (MINSPT-D II 499 with Bookplate: "Ex libris Anton Hük").

Lana, Francesco Tertio (Terzi) de. 1723. *Placita physica de motu transpirationis deprompta ex p. Francisco Tertio de Lanis è Soc. Jesu. Laureatis honoribus illustrissimorum dominorum, dominorum, dum in antiquissima ac celeberrima Universitate Viennensi, promotore r.p. Antonio Vanossi, e Societate Jesu, aa.ll. & philosophiae doctore, ejusdemque professore ordinario, prima aa.ll. & philosophiae laurea insignirentur, a neobaccalaureis condiscipulis dicata. Anno reparatae salutis 1723 mense Aprili, die .* Vienna: Wolfgang Schwendimann (SKLJ-T I 32/č with Bookplate: "Ex Libris Francisci Josephi Thallmainer"). Reprint: 1724. Vienna: Schwendimann (FSLJ-20 f 53 Škerpin's acquisition with crossed out bookplate: "Bossi Antonius"; W-1531 now NUK-8297; SKLJ-T II 31/r with Bookplate: "Ex Libris Franc: Jos: Thallmainer").

Lander, John Joseph. 1953. Auger Peaks in the Energy Spectra of Secondary Electrons from Various Materials. *Phys. Rev.* 91: 1382-1387.

Lang, Victor E. von. 1870. Über eine neue Untersuchungsmethode für die Gasdiffusion, *Wien.Ber.* 62: 288-298.

Lang, Victor E. von. 1871. Versuche über Einströmung von Gasen, *Wien.Ber.* 63: 604-618.

Lang, Victor E. von. 1871. Zur dynamischen Theorie der Gase. *Wien.Ber.* 64: 485-489. Reprint: 1872. VII. Zur dynamischen Theorie der Gase. *Annalen der Physik und Chemie*, 221/2 (145): 290-294.

Lang, Victor E. von. 1872. Zur dynamischer Theorie der Gase II. *Wien.Ber.* 65: 415-418. Reprint: 1872. *Annalen der Physik und Chemie*, 223/9 (147): 157-160.

Lapp, Ralph Eugene. 1960. *Roads to discovery.* New York: Harper & Brothers Publishers.

- Lane, Timothy. 1767. Description of an electrometer invented by Mr Lane. *Philosophical Transactions of the Royal Society*. 57: 451–460.
- Láng, Benedek. 2010. *Unlocked Books: Manuscripts of Learned Magic in the Medieval Libraries of Central Europe*. Penn State Press.
- Laplace, Pierre Simon. 1814. *Essai philosophique sur les probabilités (A philosophical essay on probabilities)*. Paris: widow Courcier. Reprints by the same publisher: 1816; 1819 (NUK-30479).
- Laska, Antun. 1874. O novoj fizikalnoj teoriji. *Izvišće o kralj. Velikoj gimnaziji u Požegi*. Požega: Kraljević. 3-13.
- Laska, Antun. 1876. Prilog k fizikalnim teorijam. *Rad Jugoslavenske akademije znanosti i umjetnosti*, 34: 59-74.
- Laska, Antun. 1877. Edlundova teorija munjevitih pojava. *Izvišće o kralj. Velikoj gimnaziji u Osijeku* (Zagreb). 3–45.
- von Laue, Max. 1959. Geschichte des Elektrons. *Phys. Bl.* 15/3: 105-111. Translation of Usher Ionovich Frankfurt (Франкфурт): 1969. *Статьи и речи. Перевод с немецкого (Stat'ii i rechi Perevod s nemetskogo, Publications and speeches)*. Moscow: Nauka (Наука, Science).
- Lavoisier, Antoine Laurent, Laplace, Pierre Simon. 1783 (1784). Mémoire sur la chaleur, Lū á l'Académie Royale des Sciences, 18 June 1783. Printed before August 1783. *Histoire de l'Académie Royale des Sciences (Paris)*. Anne 1780, Avec les Mémoires de Mathématique et Physique, 355-408. Translation: 1982. New York: Neale Watson Academic Publications Inc.
- Lavrič, Ana. 2010. Ljubljanske baročne bratovščine in njihovo umetnostno naročništvo. Jezuitske kongregacije. *Arhivi*. 33/2: 251–286.
- Lavtar, Luka. 1873. Vse prikazni v naravi so nasledek ene same preproste stvari z eno samo bistveno močjo (s privlačnostjo). *Letopis SM*. 71–88.
- Lazarević, Žarko. 1987. Začetki uvajanja telefonije v Ljubljani. *Kronika* (Ljubljana). 35/1–2: 97–100.
- Leblanc, Maurice. 1 December 1880. Etude sur la transmission électrique des impressions lumineuses. *La Lumière Électrique*. 11: 477-481.
- Lebmacher, Carl. 1993. *Klagenfurt in alter Zeit: Historische Bilder aus dem Alltag in Kärnten* (edited and compiled by Josef Höck). Klagenfurt: Verlag des Geschichtsvereines für Kärnten.
- Lecchi, Giovanni Antonio, S.J. 1765. *Idrostatica esaminata ne' suoi principi e stabilita nelle sue regole della misura dell'acque correnti dal p. Antonio Lecchi della compagnia di Gesù, matematico delle LL. MM. II*. Milano: Giuseppe Marelli.
- Lecchi, Giovanni Antonio, S.J. 1773. *Memorie idrostatico-storiche delle operazioni eseguite nell'inalveazione del Reno di Bologna, e degli altri minori torrenti per la linea di Primaro al mare dall'anno 1765. fino al 1772. dal p. Antonio Lecchi ... Si aggiungono altre memorie riguardanti varie spedizioni, ed operazioni analoghe fatte contemporaneamente in Germania, ed altrove 1-2*. Modena: Società tipografica.
- Lecchi, Giovanni Antonio (former S.J.). 1776. *Trattato de' canalli navigabili dell'abate Antonio Lecchi Matematico delle LL. MM. II* Milano: Giuseppe Marelli. Reprint. 1824. Milano: Giovanni Silvestri / Bologna: Marsigli.
- Lefèbvre, Jean Rodolph (Fabro, Fabri, Faber, Johannes Rudolphus). 1626. *Cursus physicus, in quo totius philosophiae naturalis corpus assertionibus et quaestionibus...: in gratiam philosophiae alumnorum perspicuè & brevitur explicatur...* Genevae: Pierre Aubert.
- Lelong, Benoit (Benoît). 1997. Paul Villard, J.-J. Thomson et al composition of rayons cathodiques. *RHS*. 50/1-2: 89-130.
- Lenard, Philipp; Wolf, Max. 1889. Zerstäuben der Körper durch das ultraviolette Licht. *Ann. Phys.* 37: 443-456.

- Lenard, Philipp. 1900. Ueber Wirkungen des ultravioletten Lichtes auf gasförmige Körper. *Ann. Phys.* 4/1: 486-507.
- Lenard, Philipp. 1905. Rayons cathodique produits par les rayons ultra-violet. *Les quantités* (ed. Abraham & Langevin). 1: 398-413.
- Lenard, Philipp. 1905. Effets produits par la lumière ultra-violette sur les corps gazeux (Effects produced by lumière ultra-violet light on gaseous matter). *Les quantités* (ed. Abraham & Langevin). 1: 416-423.
- Lenhart, John M. 1923. *Science in the Franciscan Order. A Historical Sketch*. New York: Joseph F. Wagner, Inc.
- Leskovec, Antoša. 1983. Upravni in gospodarski razvoj Maribora v 19. stoletju. *Kronika*. 31/2-3: 167-175.
- Leskovec, Antoša. 1991. Razvoj gospodarstva v Mariboru: 1752-1941. *Maribor skozi stoletja, Razprave I* (ed. Curk, Jože). Maribor: Obzorja. 313-414.
- Leskovec, Antoša. 1991. Zgodovina uprave v Mariboru 1752-1941. *Maribor skozi stoletja, Razprave I* (ed. J. Curk). Maribor: Obzorja. 229-311.
- Leskovec, Antoša. 1998. Gospodarstvo v Mariboru od srede 19. stoletja do prve svetovne vojne. *Od Maribora do Trsta: 1850-1914: Zbornik referatov (Anthology of Papers)*. Maribor: Pedagoška fakulteta (ed. Friš, Darko, Rozman, Franc). 105-125.
- Leskovec, Ivana; Suzana Stančič et al (eds.). 2013. *Heritage of Mercury: Almadén Idrija (Dediščina živega srebra: Almadén, Idrija)*. Ljubljana: Ministry of Culture of the Republic of Slovenia (Ministrstvo za kulturo Republike Slovenije).
- Leurechon, Jean; Hanzelet, Jean Appier (pseudonym Hendrik van Etten). 1642-1643. *Récréations mathématiques: composées de plusieurs problèmes plaisans & facétieux d'arithmétique, géométrie, astrologie, optique, perspective, mécanique, & d'autres rares & curieux secrets: plusieurs desquels n'ont iamais esté imprimez: première et seconde partie: la troisieme partie contient un recueil de plusieurs gentilles & récréatives inventions de feux d'artifice. La manière de faire toutes sortes de fuzées, simples & composées. Le tout représenté par figures*. 1-3. Lyon: Claude Prost.
- Lewis, George. 2005. Book Review: Rayvon Fouché, *Black Inventors in the Age of Segregation: Granville T. Woods, Lewis H. Latimer, and Shelby J. Davidson*, *ICON*, 11: 228-230.
- Leybold. 1994. *Das Geschäftsjahr 1994*. Oerlikon Bührlé Konzern.
- Liceti, 1640. *Litheosphorus, sive De lapide Bononiensi lucem in se conceptam ab ambiente claro mox in tenebris mire conservante*. Utini (Udine): Nicolai Schiratti.
- Lightfoot, Edwin Niblock Jr.; Cussler, Edward Lansing; Rettig, R.L. 1962. Applicability of the Stefan-Maxwell Equations to Multicomponent Diffusion in Liquids, *AIChE Journal (official magazine of American Institute of Chemical Engineers)* 8/5: 708-710.
- Likar, Silvo. 2007. *Vloga viteških redov na obrambnem in karitativnem področju s poudarkom na Nemškem viteškem redu na Slovenskem*, Graduate work at Ljubljana Theological faculty (Diplomska naloga). Teološka Fakulteta Univerze v Ljubljani, mentor Bogdan Kolar.
- Lind, Gunter. 1992. *Physik im Lehrbuch 1700-1850. Zur Geschichte der Physik und ihrer Didaktik in Deutschland*. Berlin: Springer-Verlag.
- Linde, Carl Paul Gottfried von. 1896. Erzielung niedrigster Temperaturen. Gasverflüssigung, *Ann. Phys.* 293/57: 328-332.
- Lindenau, Bernhard August von. 1809. *Tables Barométriques pour faciliter le calcul des nivellements et des mesures des hauteurs par le baromètre*. Gotha: R.Z. Becker (Zois' book, copy without his binding now in NUK-4248). Referred in: 1809. *Annalen der Physik*, 31/4: 451-452.
- Lindley, David. 2001. *Boltzman's Atom. The Great Paper That Launched a Revolution in Physics*. New

York, London, Toronto, Sydney, Singapore: The Free Press

Linus, Franciscus (Hall). 1661. *Tractatus de Corporum Inseparabilitate; in Quo Experiment de Vacuo, the Torricelliana, quàm Magdeburgica, and Boyliana, examinatur, veraque eorum causa detector, ostenditur, vacuum naturaliter from non-pose: unde and Aristotelica de Rarefactione sentenced there contra Assertores Vacuitatum, quam Corpusculorum demonstratur*. London: printed by Thomae Roycroft, impensis Joan. Martin, Ja. Allestry & Thomas Ditas.

Lipič, Fran Viljem (Franz Wilhelm Lippich, Fr. Guilielmus Lippich). 1823. *Observata de metritide septica in puerperas grassante*. Wien: J.G. Heubner.

Lipič, Fran Viljem (Franz Wilhelm Lippich, Fr. Guilielmus Lippich). 1834. *Grundzüge zur Dipsobiostatik oder politisch-arithmetische auf ärztliche Beobachtung gegruendete Darstellung der Nachtheile welche durch den Missbrauch der Geistigen Getränke in Hinsicht auf Bevölkerung und Lebensdauer sich ergeben (Basic characteristics of dipsobiostatik or political-arithmetical presentation of physician's observations of consequences of alcohol misuse and its influence on public health and lifetime)*. Laibach: Heinrich Wilhelm Korn. Translation edited by Zvonka Zupanič Slavec: 2005. *Osnovne značilnosti dipsobiostatike*. Ljubljana: ZRC SAZU.

Lippich, Ferdinand. 1870. Über die Breite der Spectrallinien, *Ann. Phys.* 139 (215): 465–479.

Lippich, Ferdinand. 1880. Untersuchungen über die Spectra gasförmiger Körper. *Wien. Ber.* 82/2: 15–33.

Livingston, Milton Stanley; Blewett, John Paul. 1962. *Particle accelerators*. New York: McGraw-Hill.

Llamazares, Thomà (Thomas de). 1670. *Cursus Philosophicus sive philosophia scholastica ad mentem Scoti, noua & congruentiori addiscentibus methodo disposita. Authore r.p.f. Thoma Llamazares, Hispano Vallisoletano*. Lugduni: Jean Antoine Huguétan (FSLJ-10 i 27).

Locherer, Alipius. 1740. *Clypeus philosophico-scotisticus : sive, Cursus philosophicus: juxta mentem et doctrinam doctoris subtilis Joannis Duns-Scoti elaborates*. (Stein by) Cembsij (Krems): Ignattij Antonij Präxl, Universitatis Viennensis Typograph (FSLJ-16 k 28). Reprint: 1742. Augustae Vindelicorum: Veith.

Lodge, Oliver Joseph. 1894. *The work of Hertz and some of his successors, being the essence of a lecture delivered at the Royal Institution on Friday evening, June 1, 1894, with additions and appendices reprinted from "The Electrician," etc.* 3rd edition. London: The Electrician Print. and Pub. Co. 58 pages with additional 73 pages making together pages [iv] + 133. Reprint: 1897. *Signalling across space without wires: Being a description of the work of Hertz & his successors*. London: The Electrician Print. and Pub. Co.

Löffler, Augustin. 1872. Novi nauk o geometriji. *Siebente Jahresberichte der k. k. Ober-Realschule zu Rakovac in der k. k. Kroatisch-Slavonischen Militär-Grenze*. Rakovac/ Agram (Zagreb): Albrecht. Pages 3–17 with one illustration

Löffler, Augustin. 1874. Tjelovježba u pučkoj školi. *Ii Obća hrvatska učiteljska skupština u Petrinji 25.–27. kolovoza 1874*. Zagreb: Centralni odbor obćih hrvatskih učiteljskih skupština. 223–237.

Löffler, Augustin. 1879. *Gimnastika za učitelje pučkih učiona i učitelje pripravnike*. Zagreb: Kr. hrvatsko-slav.-dalm. zemaljska vlada.

Lohmeier, Philipp. 1671. *Exercitatio moralis de simulation and dissimulatione*. Helmstedt: Mullerus.

Lohmeier, Philipp. 1674. *Philippi Lomeieri Oratio De Astrologiae Iudiciariae Vanitate Et Siderum Influxu: Habita In Acad. Hasso-Schaumburgica Ao. MDCLXXIV. Ad D. XXV. Iunii, Cum ipsi ex Clementissimo decreto Serenissimae Principis Naturalis Scientiae publica & Ordinaria Professio esset demandata*. Rinteln: Wächter.

Lohmeier, Philipp. 1676. *Exercitatio physica de artificio navigandi per aërem Quam Deo T.O.M. clementer annuente in Illustri Acad. Hasso-Schaumburgica, præsiede Philippo Lohmeiero*

Physicæ Profess. Publ. & Ordinario, In Auditorio Majori publico eruditorum examini subjiciet ad diem 4. martii anno 1676. Franciscus David Prescheur (Frescheur), Cassellanus Hassus.

Wittenberg/Rinthelii (Rinteln): Wächterianis, Academ. Typogr.; Reprints: 1679. Wittenberg: Borckhard; 1708. Rinthelii: Enax; 1784. Rinthelii: Enax; 1784. *Philippi Lohmeieri, ... Dissertationem physicam de artificio navigandi per aerem, die 4 martii anni 1676, resp. Franc. Dav. Prescheur habitam, et recusam ibidem anno 1708, ex collectione Dissertationum suarum, ut "rariorem", reipublicae litterariae communicat Nicolaus Barkey, ... Accedunt Petri Francisci Lanae cogitata de arte aeronautica.* Hagae Comitum: Apud I. Van Clec. Translations: 1784. *Von der Luftschiffkunst Ins Deutsche übersezt und mit Anmerkungen begleitet. Inventis, facile est, addere.* Tübingen: Jacob Friedrich Heerbrandt; March 1784. *Die Lohmeierische Dissertation von der Kunst in der Luft zu schiffen in ihrer Urschrift und daneben gesetzten teutschen Uebersetzung dem Publikum mitzutheilen war sogleich beschlossen als man das Original vorfand. Respondent Franciscus David Frescheur, mit Beteiligung von Philipp Lohmeier (Exercitatio Physica De Artificio Aëronautico = Physicalische Abhandlung von der Kunst in der Luft zu schiffen), Arolsen in northern Hesse: Universitäts- und Landesbibliothek Sachsen-Anhalt; Modern Reprints: Lohmeier, Philipp; Rhotert, Johannes (Rhoters) (ed.). 1908. Herr Domkapitular Johannes Rhoters (Rhotert): „Die Kunst der Luftschiffahrt“ nach Lohmeiers Dissertation aus dem Jahre 1677. *Eine Erweiterung des Vortrages als selbständige Arbeit erscheint im vorliegenden Jahresbericht of Verein of Naturwissenschaft in Osnabrück, Sitzung am 21. February 1908; 1911. Philipp Lohmeyer's Physikalische Abhandlung über die Kunst der Luftschiffahrt vom Jahre 1676. Jahresbericht des Naturwissenschaftlichen Vereins Osnabrück, Osnabrück: Meinderssche Buchhandlung. 17: 155-183.**

Lohmeier, Philipp. 1677. *Observationes curiosae miscellanae.* Rinteln: Wächter.

Lohmeier, Philipp (president of exam); Hoffbaur, J.C.; Prudent de LaFayolle; Reiche, J.C.; Pestel, Johann (responding student). 1678. *Exercitationum*

Physicarum De Paradoxis Gravitatis & Levitatis. Rinteln: G. Wächter.

Lohmeier, Philipp. 1680. *Theses selectiores de aere Quas In Illustri Gymnasio Luneburgensi Praeside Philippo Lohmeiero, Colleg. EquestrisInspectore Et Profess. Publ. Ad Diem Martii Publico Eruditorum Examini Sistet Georgius Christianus Marggraff Wendorffensis Saxo.* Luneburgi (Lüneburg): Praelo Kelpiano.

Lommel, Eugen von. 1871. Ueber Fluorescenz, *Ann.Phys.* 143 (219/5): 26-51. Simultaneous print: 1871. Erlangen: E. Th. Jacob.

Lorenz, Hans. 15 March 1917. Theorie der Röhrenfedermanometer, *Phys. Z.* 18/6: 117-121.

Losada Prada, Luis de. 1730. *Cursus philosophici regalis collegii salmanticensis Societatis Jesu, in tres partes diuisi : secunda pars, continens Physicam seu Naturalem Philosophiam, de corpore naturali generatim.* Salmanticae: Eugenii Garcia de Honorato et S. Miguel (Eugenio García de Honorato y San Miguel). Reprint: 1749. *Cursus philosophici regalis collegii salmanticensis societatis Iesu: in compendium redacti, et in tres partes diuisi: secunda pars: continens physicam, seu philosophicam naturalem, de corpore naturali generatim.* Salamanca: Antonio José Villargordo y Alcaraz. Promotions: Keri, Francizek B. (Franc Borgia Kéri); Joseph Apponyi. 1752 & 1753-1754. *Dissertatio Physica de corpore generatim, deque opposito eidem vacuo (vacuo). Dum Pro Prima Exercitatione Scholastica Theses Logicas in alma ac Celeberr. Archi-Episcopali Societatis Jesu Universitate Tyrnaviensi Anno M.DCC.LIII die 13 Apr. Publice Propugnaret Perilustris, ac Generosus Dominus Joan. Mitterpacher de Mitternburg. Praeside R.P. Josepho Apponyi, e Societate Jesu, AA. LL. & Philosophiae Doctore, ejusque in Logicis Professore Ordinario, Auditoribus Oblata.* Tyrnaviae: Typis Acad. S. J. (W-1483 now NUK-8257 with Propriety entry: "Inscr. Catal. Bibl. Philos. Coll. Labaci S.J. 1754"); Francizek B. Keri. 1755. *Dissertatio physica de corpore generatim, de motu corporum, de causis motuum in corporibus: Assertiones ex universa philosophia quas ... publice propugnandas suscepit Christophorus Fáy ex praelectionibus Martini*

- Puchperger, Ignatii Hertl, Georgii Losska
Cassouiae, Tyrnaviae: Typis Acad. S. J.
- Loschmidt, Josef. 1865. Zur Grösse der Luftmoleküle. *Sitzungsberichte der Kaiserlichen Akademie der Wissenschaften Wien.* 52/2: 395–413. English translation by William Porterfield and Walter Kruse: October 1995. On the size of the air molecules, *Journal of Chemical Education*, 72/10: 870-875.
- Loschmidt, Josef. 1866. Zur Theorie der Gase (On the theory of gases). *Wien.Ber.* 54: 646-662 (29 November 1866).
- Loschmidt, Josef. 1867. Theorie des Gleichgewichtes und der Bewegung eines Systems von Punkten (Theory of equilibrium and of motion of a system of points). *Wien.Ber.* 55: 523-538.
- Loschmidt, Josef. 1869. Der Zweite Satz der mechanischen Wärmetheorie. *Wien.Ber.* 59: 395–418.
- Loschmidt, Josef. 1870. Experimental-Untersuchungen über die Diffusion von Gasen ohne poröse Scheidewände. *Wien.Ber.* 61: 367-380; 62: 468-478.
- Lovato, Italo. 1959. I Gesuiti a Gorizia (1615-1773). *Studi Goriziani.* 25 (January-June): 85-141.
- Lower, Richard; Carnaro, Luigi; Ludovici, C. 1738. *Englischen Artzney-Büchlein, das ist, Des weltberuhmzen englischem medici Hrn. D. Loweri und unterschiedlichen anderer vortrefflichen Medicorum in London nützliche...in gantz neues sehr nützlich.* Leipzig: Wiedmann (KSSKL).
- Lu, Dalong. 1999. Guimao (Gui Mao) Yuan Calendar (1742-1911) and Isaac Newton's Theory of the Moon's Motion. *The Spread of the Scientific Revolution in the European Periphery, Latin America and East Asia: Proceedings of the XXth International Congress of History of Science (Liège, 20-26 July 1997).* (ed. Lértora Mendoza, Celina Ana; Nikolaidēs, Efthymios; Jan Vandersmissen, Jan) Turnhout by Antwerp: Brepols Publishers. Vol. 5: 169-181.
- Lu, Ling-feng; Yun-li Shi (石雲里). 2003. Accuracy of Solar Eclipse Predictions Made in the Qing Dynasty, *Zhongguo Keji Shiliao (China Historical Materials of Science and Technology)* 24: 283-290.
- Lubej, Uroš. 2005. Slikar Almanach in njegovi naročniki, *Almanach in slikarstvo druge polovice 17. stoletja na Kranjskem* (Edited by: Barbara Murovec; Matej Klemenčič; Mateja Breščak). Ljubljana: ZRC SAZU.
- Lubkin, Gloria Becker. April 1992. Special Issue: John Bardeen. *Phys. Today.* 45/4: 23-25.
- Ludwig, Karl (Carl Friedrich Wilhelm Ludwig). 1856. Diffusion zwischen ungleich erwärmten Orten gleich zusammengesetzter Lösungen. *Wien. Ber.* 20: 539-539.
- Luger, Daniel. 2014. *Humanismus und humanistische Schrift in Der Kanzlei Kaiser Friedrichs III. (1440-1493).* Dissertation, University of Vienna. Historisch-Kulturwissenschaftliche Fakultät (supervisor (Betreuerin) Lackner, Christian).
- Luger, Daniel. 2016. Humanismus und humanistische Schrift in Der Kanzlei Kaiser Friedrichs III. (1440-1493). *Mitteilungen Des Instituts Fur Osterreichische Geschichtsforschung (MIÖG)*, Ergänzungsband 60, Vienna: Böhlau-Verlag.
- Lukács, Ladislaus S.J. 1978, 1982. *Catalogi personarum et officiorum provinciae Austriae S.I. I-II.* Romae: Institutum historicum Societatis Iesu.
- Lukács, Ladislaus S.J. 1987-1988. *Catalogus generalis seu Nomenclator biographicus personarum Provinciae Austriae Societatis Jesu (1555-1773), I-III.* Romae: Institutum historicum Societatis Iesu.
- Lukanc, Maja. 2016. *Ana Celjska.* Celje: Pokrajinski muzej.
- Lull, Ramon; Rhazi; Albertus Magnus; Skot, Michael. 1546. *Preto... Margarita novae... philosophorum lapium... annales Rhaimundo, Rhazi,*

Albertus & Michael Scoto... (NUK-5146, Bookplate of the Abbot in Stična Laurenti, anno 1581).

Lummer, Otto. 1900. Le rayonnement des corps noirs (translated by R. Dongier and M. Lamotte at Sorbonne). *Rapports présentés au Congrès International de physique réuni à Paris en 1900, sous les auspices de la Société française de physique* (ed. Poincaré, Lucien; Guillaume, Charles-Édouard). 1-3. Paris: Gauthier-Villars. 2: 41-99.

Mach, Ernst. 1862. Über die Molecularwirkung der Flüssigkeiten vorgelegt in der Sitzung am 15. Mai 1862 (On the molecular action of liquids presented at the meeting on May 15, 1862). *Wien.Ber.* 46: 125–134. Separate print: 1862. *Über die Molecularwirkung der Flüssigkeiten Sonder-Abdruck aus dem XLVI. Bd. der Sitzungsab. der kais. Akademie d. Wissenschaften (Special print from the volume XLVI of the session the Imperial Academy d. Sciences)*. Wien: k.k. Hof-und Staatsdruckerei.

Mach, Ernst. 1872. *Die Geschichte und die Wurzel des Satzes von der Erhaltung der Arbeit: Vortrag gehalten in der K. Böhmisches Gesellschaft der Wissenschaften am 15. Nov. 1871*. Prag: J.G. Calve.

Mach, Ernst; Salcher, Peter. 8 November 1889. Optische Untersuchung der Luftstrahlen. *Wien. Ber.* 98: 1303–1309 (9 photographs in appendix). Reprint: 1890, *Annalen der Physik*, 277/9: 144-150.

Mach, Ernst. 1903. *Populär-wissenschaftliche Vorlesungen*. Mit 60 Abbildungen. Leipzig: Barth.

Mach, Ernst. 1912. *Die Mechanik in ihrer Entwicklung : historisch-kritisch dargestellt*. Leipzig: Brockhaus.

Mach, Ernst. 1919. *Die Principien der Wärmelehre*. Leipzig: Barth.

Mach, Maria (anonymous). 1912. *Erinnerungen einer Erzieherin. Nach Aufzeichnungen von (Marie Mach) mit einem Vorwort hrsg. von Ernst Mach*. Wien/Leipzig: Braumüller, VI+319 pages. 2nd bettered reprinting: 1913. Wien: Braumueller, VIII+333 pages in format 8°.

Madey, Theodore Eugene, Brown, William Charles (ed.). 1984. *History of Vacuum Science and Technology: a special volume commemorating the 30th anniversary of the American Vacuum Society, 1953-1983*. New York: American Vacuum Society, American Institute of Physics.

Madey, Theodore Eugene. 1984. Early applications of vacuum, from Aristotle to Langmuir. *History of Vacuum* (ed. Madey, Theodore Eugene; Brown). 9-16.

Maffei, marquess Francesco Scipione de; Tartarotti, Girolamo; Melchior, Bartolomeo; Cavalcabò, Clemente Baroni Cavalcabò. 1751. *Apologia del congresso notturno della lammie a sia risposta di Girolamo Tartarotti all'arte magica dileguata del Sig. March. Scipione Maffei ed all'opposizione del Sig. Assessore Bartolommeo Melchiori. S'aggiunge una Lettera del Sig. Clemente baroni di Cavalcabò*. Venezia: Simone Occhi (NUK-5204).

Magalotti, Lorenzo (ed.). 1666. *Saggi di naturali Esperienze fatte nell'Accademia del Cimento solto la protezione del principe Leopoldo di Tosca no e descritte dal segretario di essa accademia (= Magalotti)*. Firenze: Giuseppe Cocchini. Reprint: 1691. Firenze: Nella Nuova Stamperia de Giovanni Filippo Cecchi.

Magni, Valerijan (Valeriano). October 1647. *Demonstratio ocularis Loci sine locato, corporis successive moti in vacuo, lumines nulli corpori inhaerentis, a Valeriano Magno, fratre cappuccino, exhibita, Serenisse, Principibus Vladislao IV Regi, et Ludovicae Mariae Reginae Poloniae et Sveciae, Magis Ducibus Lithuaniae, Virgini Deiparae, ex voto sacra et d(ed)icata*. Warsaw.

Magni, Valerijan. 8 September 1642. *De luce mentium et eius imagine*. Romae: Francisco Caballi; Reprints: 1645; 1646. Viennae: Mattheo Ricti.

Magni, Valerijan. October 1647. *Demonstratio ocularis Loci sine locato, corporis successive moti in vacuo, lumines nulli corpori inhaerentis, a Valeriano Magno, fratre cappuccino, exhibita, Serenisse, Principibus Vladislao IV Regi, et Ludovicae Mariae Reginae Poloniae et Sveciae, Magis Ducibus Lithuaniae, Virgini Deiparae, ex*

voto sacra et d(ed)icata. Varsaviae: Peter Elert; Reprints: 1647. Cracoviae: Francisco Caesarei; 1648. Bolononiae: haeredis Victor Benati; 1848. Varsaviae: Peter Elert; 1649. Venetiis (Venezia): Herz; 1652; 1661. Coloniae Agrippinae: Jodoc Kalcov.³⁵⁷³ Translation: 1959. Naoczny dowod mozliwosci istnienia prozni. *Kwartalnik historii nauki i techniki*. (Warszaw). 4/1: 77-104.

Magni, Valerijan. 1648. *Principia et specimen philosophiae*. Köln; Reprint: 1652. Köln: Jodocus Kalcovius.

Magni, Valerijan. 1654. *Lux in tenebris lucens quam tenebrae non comprehendunt*. Straubinga: Gallus (S).

Magni, Valerijan. 1660. *Opus philosophicum*. Lithomisslii (Leitomischl): Joannis Arnolti.

Magnus, Albertus. 1494. *Divi Alberti Magni phisicor(um) sive De phisico auditu libri octo*. Venetiis: Joan et Forlivio Gregorio (KSSKL).

de Maillard, Sebastian. 1784. *Théories des machines mues par la force de la vapeur de l'eau*. Vienna & Strasburg: frères Gay.

De Mairan, Jean Jacques D'Ortous (Dortoux). 1716. *Dissertation sur la glace ou explication physique de la formation de la glace et de ses divers phénomènes*. Paris. Reprints: 2nd edition 1717; 3: 1730; 4: 1749. German Translation: 1752. *Des Herrn von Mairan Eines Von den Vierzigen der Französischen Akademie, der Königlichen Akademie der Wissenschaften in Paris Mitgliebes etc. Abhandlung Von dem Eisse, Oder Physikalische Erklärung der Entstehung des Eisses, und der dabey vorkommenden verschiedenen Erscheinungen. Aus dem Französischen ins Deutsche übersetzt*. Leipzig: Friedrich Lankischens Erben (J-428 next W-1537 now NUK-8535 with Propriety entry: „Coll. Labac. S.J. 1758“).

Maite, Bernard. 1981. *La Lumière*. Paris: Seuil.

Maixner, Rudolf. 1960. *Charles Nodier et l'Illyrie*. Paris: Didier.

Majolo, Simone (Mayolus, Simon). 1597. *Collegnia de admirandis naturae rebus sev dies caniculares*. Roma: Zannetti (NUK-GS 8883). Reprints: 1600 Oberursel (Ursellis) northeast of Mainz; 1607. Mainz (Moguntiae) / Köln (Coloniae) / Frankfurt (Helenopoli); 1654. *Dies caniculares, sive colloquia tria et viginti physica nova et penitus admiranda, quae aut in aethero sunt, aut in Europa, Asia atque Africa...* Vulturara in southeast Italy (FSNM); 1691. Offenbach (by Frankfurt): Joannes Martin Schönwetter & Bonaventura de Launoy (NUK-5170).

Mako, Paul von Kerek-Gede, S.J. 1764. *Compendiaria Matheseos institutio quam in usum auditorum philosophiae elucubratus est*. Viennae. Reprint: 1766. Vindobonae: Trattner; 3: 1771. Vindobonae: Trattner (NUK-4303); 4: 1781. Vindobonae: Trattner (FSNM).

Mako, Paul von Kerek-Gede. 1772. *Dissertatio physica de natura et radiis Fulguris; de proprietatis Tonitruui et mediis contra ictum fulminis*. Vienna: Job. Thomas Edlen von Trattner. Reprint: 1773. Goritiae: Valerii de Vakeriis. Translation of Joseph Edler von Retzer: 1772. *Physikalische Abhandlung von den Eigenschaften des Donners und den Mitteln wider das Einschlagen*. Verfasst von Paul Mako, der S. J. Lehrer der Mathematik und Experimentalphysik in dem k.k. Theresianum und Joseph Edlen von Retzer, seiner Zuhörer in das Deutsche übersetzt, *Physikalische Abhandlung von den Eigenschaften des Donners und den Mitteln wider das Einschlagen*. Wien: Job. Thomas Edlen von Trattner. Reprint of translation: 1775. *Physikalische Abhandlung von den Eigenschaften des Donners und den Mitteln wider das Einschlagen*. Hr. Mako von Kerek-Gede Prof. Apost. und Lehrer der Mathematischen Wissenschaften in... Ljubljana: Typis Joannis Friderici Eger (Bind to: Schöttl, Maffei, Tschokl, *Tentamen Philosophicum...*).

Mal, Josip. 1925. Auersperg (keyword). *SBL*, 1: 19.

Mangold, Joseph S.J. 1755-1756. *Philosophia Rationalis et Experimentalis, hodiernis discentium studiis accommodata*. Autore P. Josepho Mangold. S. J. in Electorali Universitate Ingolstadiensi nuper *Philosophiae Professore publ. ac ordin. Tomus I*.

³⁵⁷³ Cygan, 1989, 313-319.

Logicam et Metaphysicam complectens. Tomus II Physicam Generalem Complectens, Tomus III Physicam Particularem Complectens. Ingolstadii et Monachii (Munich): Joannes Franciscus Xav. Cratz (Crätz) & Thomae Summe (J-408 now NUK-4420 with Propriety entry: "Inscripto Catalogo Bibliotheca Collegis Soc. JESU Labac." without date in bookplate, not catalogued by Wilde; FSLJ-6 h 10-12 with propriety entry: *Vincentio Mariaschitz procuratus* (Vincent Marjašič)).

Mann, Golo. 1971. *Wallenstein*. Frankfurt: Fischer.

Marášek, Wilhelm. 1876. Ein Beitrag zur Bestimmung der Mitagslinie, *Jahresbericte Rakovac*. June 1876, 37-45.

Marek, Bernhard; Pöschl, Jakob. 1865. Jahres-Uebersicht der meteorologischen Verhältnisse von Steiermark. Nach der Angaben von 11 Beobachtungs-Stationen zusammengestellt. *Mittheilungen des naturwissenschaftlichen Vereines für Steiermark III für 1864*, 3: 151–175.

Marek, Bernhard; Pöschl, Jakob. 1867. Jahres-Uebersicht der meteorologischen Verhältnisse von Steiermark. Nach der Angaben von 10 Beobachtungs-Stationen zusammengestellt. *Mittheilungen des naturwissenschaftlichen Vereines für Steiermark IV für 1865*, 4: 123–150.

Marey Monge, Edmond. 1847. *Études sur l'aérostation*. Paris: Bachelier.

Marinčić, Aleksandar. 2006. *Nikola Tesla – stvaralaštvo genija/Nikola Tesla – The Works of a Genius*, Beograd: Srpska akademija nauka i umetnosti i Odbor za obeležavanje 150 godina rođenja Nikole Tesle.

Marković, Ivan. 1994. Gimnazija z italijanskim učnim jezikom v Kopru. Od "Kolegija plemičev" do Gimnazije Gian Rinaldo Carli skozi štiri stoletja nepretrgane tradicije (Gymnasium Koper), *Zbornik za povijest školstva i prosvjete = Zbornik za zgodovino šolstva in prosvete = Zbornik za istoriju školstva i prosvete = Collected papers for the history of schooling and education* (Zagreb: Hrvatski školski muzej & Ljubljana: Slovenski šolski muzej & Beograd: Pedagoški muzej), 27/3: 112–119.

Marković, Ivan. 1996. La biblioteca di Gian Rinaldo Carli. La libreria dell'Accademia de' Risorti dal 1760 al 1806. *Acta Histriae*. 5: 79–90.

Marković, Željko. 1968-1969. *Ruđe Bošković*. 1-2. Zagreb: JAZU.

Martin, Benjamin. 1766. *A description of the nature, construction and use of the Torricellian, or simple barometer with a scale of rectification ...* London: printed for author (Žiga Zois's book now NUK-8540). Bind to seven Martin's works of similar topics (Žiga Zois's books now NUK-8539-8546) including: 1766. *The description and use of a new, portable, table air-pump and condensing engine: with a select variety of capital experiments, which together with the different parts of the apparatus and glasses, are illustrated by upwards of forty copper-plate figures*. London: printed for author as self-publishing (Žiga Zois's book valued as (1:00) now NUK-8539). 1765. *Optical essays: Containing, I. A practical description of the several sorts of single, solar, and compound microscopes; with their apparatus, and latest improvments. II. The nature of vision in insects demonstrated by microscopic observations. III. A catalogue of all principal microscopic objects. IV. The use of the reflecting telescope as an universal perspective for viewing every sort of object in the greatest perfection. V. The manner of computing the magnifying power in single and double microscopes. VI. A new method of applying a micrometer to take the dimension: of small objects. VII. An illustration of the whole in a great variety of figures on a large copper-plate*, London: printed for author (NUK-8542); 1771. *The description and use of an orrery of a new construction Representing in the various Parts of its Machinery all the Motions and Phoenomena of the Planetary System ; To which is subjoin'd a mathematical theory For calculating the Wheel-Work to the greatest Degree of Exactness*. London: printed for author (Žiga Zois's book now NUK-8544); 1772. *Thermometrum magnum: or, Grand standard thermometer ...* London: printed for author (Žiga Zois's book now NUK- GS I 8541); 1766. *The new art of surveying by the goniometer; containing, I. A new method of measuring angles by this new instrument ... II. The description and use of a new protractor ... III. The rationale of reducing any*

multangular figure to a plain triangle ... IV The principles of levelling ... The whole illustrated by a great variety of copper-plate figures. London: printed for author.

Martin, Benjamin. 1759. *New Elements of Optics or the Theory of the Aberrations, Dissipation and Colours of Light; of the General and Specific Refractive Powers and Densities of Mediums; the Properties of Single and Compound Lenses and the Nature, Construction and use of Refracting and Reflecting Telescopes and Microscopes of every sort hitherto published.* London: printed for author (Žiga Zois's book now NUK-GS I 7948). Translation: 1781. *Elementi delle scienze e delle arti letterarie di Beniamino Martin. Traduzione dall'inglese in francese, e dal francese in italiano.* Bassano: Remondini di Venezia, three volumes (POMPI).

Martin, Benjamin. 1758. *New principles of geography and navigation: in two parts. Part I. containing the theory of the true figure and dimensions of the earth, deduced from actual mensuration, and applied to a just construction of maps and charts for land and sea use ... Part II. containing a table of meridional parts ...* London (Žiga Zois's book now NUK-GS IV 10579).

Martin, Benjamin. 1735. *The Philosophical Grammar. Part I. Somatology... II. Cosmology... III. Aerology... IV. Geology...* London: John Noon. Reprints: 1738. London: John Noon; 1748. London: John Noon; 1753. London: John Noon; 1755. 5th Edition. London: John Noon; Italian translations 1750. Venezia: Remondini; 1753 Venezia: Remondini; 1760 Venezia: Remondini; 1769. *Gramatica della scienze filosofiche, o Breve analisi della filosofia moderna appoggiata alle sperienze... Quarta ed. veneta : novellamente illustrata e con somma diligenza ricorretta... tradotta dall'inglese in francese e dal francese in italiano.* Bassano/Venezia: Remondini (NMLJ-6355 probably as former Erberg's book). Dutch translations: 1737. *Filozofische Onderwijzer: of algemeene schets der hendaagsche ondervindelijke natuurkunde.* Amsterdam: Isaac Tirion. Translation of Wagenaar, Jan: 1744. Amsterdam: Isaac Tirion; 1765. ... 3. *Druk in veelerlei opzigten verbeterd.* Amsterdam: M. Meijer.

Martin, Craig. 2011. *Renaissance meteorology: Pomponazzi to Descartes.* Baltimore: Johns Hopkins University Press,

Martin, Louis-Aimé M.L. (Aimé-Martin). 1838, 1843. *Lettres édifiantes et curieuses concernant l'Asie, l'Afrique et l'Amérique. II-IV.* Paris: Société du Panthéon Littéraire.

Martinitz, Bernard count (anonymous, in frontpage year 1675). 1674. *Quadratura circuli cryptopolygraphici.* 1-2. Prague: Joan Arnolt de Dobrosławina.

Martinović, Ivica. 1992. Filozofska i prirodoznanstvena istraživanja hrvatskih isusovaca od Markantuna de Dominisa do Josipa Franje Domina. *Isusovačka baština u Hrvata* (ed. Rauter Plančić, Biserka). Zagreb: Muzejsko-galerijski centar. 77-85.

Martinović, Ivica. 1992. Ljetopis filozofskih i prirodoznanstvenih istraživanja hrvatskih isusovaca. *Isusovačka baština u Hrvata.* 87-97.

Martzloff, Jean-Claude. 2000. Les activités scientifiques (mathématiques, astronomie) des missions catholiques au Japon et en Chine du milieu du XVI^e siècle au milieu du XIX^e siècle. *História das Ciências.* 305-329.

Mastrio de Meldula (Mastri, Mastrius), Barthol; Belluto Catanensi, Bonaventura; Archbishop Cardinal Alois Caponio. 1644. *Disputationes in Arist. stag. libros physicorum, quibus ab adversantibus tùm veterum, tùm recentiorum iaculis Scoti philosophia vindicatur. A.P.P. magistris Bartholomeo Mastrio de Meldula, eminentissimi card. caponii theologo, & Bonaventura Belluto de Catana, olim in augusto S. Antonii minor con. Patavino collegio regentibus.* Dedicated to Archbishop of Ravenna Cardinal Alois Caponio (Luigi Capponi). Venetiis: Ginammi (FSLJ-10 left b 1; 10 b 46-51, propriety entries: "Joanni Bernardini Allia alionio; 2. Jo, Bapot Pallato; Marci Antonio Francesci/ Innocentio X/ ex libris Con(ven)tus Labac(i) a regio observant/ Octavianus Cameranus"). Followed by the works of the same authors and printer: 1646. *Disputationes in XII. Arist. Stag. libros metaphysicorum: quibus ab*

aduersantibus tum veterum, tum recentiorum iaculis Scoti metaph. vindicatur / Tomvs prior, : In quo agitur de ente, vt sic, eius principijs, atque passionibus. and Disputationes in organum Aristot quibus ab aduersantibus tum veretum, tum recentiorum iaculis Scoti Logica vindicatur a PP. Magistris Bartholomeo Mastro de Meldula ... Bonaventura Belluto de Catana. Reprint: 1708. Philosophiae ad mentem Scoti Cursus integer. Venetiis: Nicola Pezzana (FSLJ-18 a 5-7). Extended reprint: 1727. RR. PP. Bartholomaei Mastii de Meldula et Bonaventurae Belluti de Catana Ord. Minor. Convent. Magistr. Philosophiae ad mentem Scoti Cursus integer. Tomus I. Continens disputationes in Aristotelis Logicam. Tomus II. Continens disputationes ad mentem Scoti in Aristotelis libros Physicorum. Tomus III. Continens disputationes ad mentem Scoti in Aristotelis libros de anima, de generatione et conuptione, de coelo et metheoris. Tomus IV. Continens disputationes ad mentem Scoti in duodecim Aristotelis libros Metaphysicorum. et V. Editio novissima a mendis expurgate. Venetiis: Nicola Pezzana (NUK-GS 5021).

Mathon, Franz Eugen (Franjo, František). 1855. Über (Ueber, Uiber) die Natur der Wärme (Nature of kinetic theory of heat), *Programm des k.k. Obergymnasiums in Fiume: veröffentlicht am Schlusse des Schuljahres 1854/55. IV. Jahrgang (Yearly Program of Rijeka (Fiume) Grammar School in 1854/55)*. Fiume (Rijeka): Anton Karletzky for Kaiserlich-Königliches Obergymnasium. Pp. 3-17. Bind to: Schulnachrichten vom pr. Director Stefan Viditz (Vidic).

Mathon, Franz Eugen (Franjo, František). 1861. Organisation neuer und Reorganisation schon bestehender Unter-Realschulen, von direktor dr. Mathon, *Programm der Selbständigen Communal-Unter-Realschule in Brünn (Programm of Communal Lower Real school in Brno, Communal-Realschule in Altbrünn, (Staré Brno at West Brno))*, Brünn (Brno): Carl Winiker, 20-23.

Mathon, Franz Eugen (Franjo, František). 1870. *Průprava k vědě hospodářské čili vysvětlení základních jejích pojmu z vědy přírodní. Sestavil F. Mathon, redaktor Rolníka"orgánu c.k. moravské sl. společnosti hospodářské a věnoval všem spolkům*

hospodářským na Moravě (Preparation for economic sciences by explanation of its basic concepts from natural science. Compiled by F. Mathon, editor of the "Peasant" organ of Moravian economic society and dedicated to all economic associations in Moravia). Brno: nákladem hospodářského spolku (Economic association).

Mathon, Franz Eugen (Franjo, František). 1871. *Listy z vědy hospodářské: Čítanka pro pokračovací vyučování v hosp., obsahující zákl. výsk. o životě rostlin, o hnoji a o náhradě toho, co se půdě rozličnými sklizněmi ubírá...* (*Letters from economic science: A reader for continuing teaching in economics, containing basic exc. about plant life, manure and the replacement of what is removed from the soil by various harvests ...*), Brno.

Matteucci, Carlo. 1841-1842. *Lezioni di fisica di Carlo Matteucci date nella I. e R. Università di Pisa. Volume 1 (1841): Proprietà generali dei corpi, Cognizioni elementari di meccanica, Gravità, Attrazione molecolare, Idrostatica e idrodinamica, Proprietà fisiche dei gas, Elasticità, Acustica; volume 2 (1841): Fenomeni elettrici; volume 3 (1842): Calorico, Meteorologia, Luce*. third edition 1-3. Pisa: Nistri. Reprint: 1852. *Lezioni di Fisica*. 4th Edition. Napoli: Gaetano Nobile.

Mattox, Donald Moss. 2000. Ion plating - past, present and future (A Concise History of Vacuum Coating Technology), *Surface and Coatings Technology*, Numbers. 133-134: 517-521 (also separate offprint on pages 1-5).

Mattox, Donald Moss. 2002. *The history of vacuum coating technology*. Albuquerque, New Mexico: Donald Moss Mattox.

Mattox, Donald Moss. 2003. The foundations of vacuum coating technology. *Proceedings of the annual technical conference- society of vacuum coaters*, no. Conf 46: 11-22. Extended reprint on 150 pages: 2003. *The foundations of vacuum coating technology [a concise look at the discoveries, inventions, and people behind vacuum coating, past and present]*. Berlin: Springer Norwich/ New York: Noyes Publ./ William Andrew.

- Mattox, Donald M. 2018. *The foundations of vacuum coating technology*. Second edition, Oxford: William Andrew.
- Mauro, Silvestro. 1658. *Quaestiones philosophicae Liber Quinque*. 1-5. Romae (Stična ST-22/83 109^f; NUK-4668, liber Quator, of student Andrea Portner in Rome in Mauro's class. Bookplate: Simon Komovic J.Vd; Franciscus Karolus de Schwozen A.V.D). Reprint: 1670. *Quaestionum philosophicarum: liber primum continens primam partem logicae nec est summulas, questiones poemiales ad philosophiam a scientias a questiones de universalibus in communi... liber 4 Continens Quaestiones Physicas De Mundo, & Caelo, De Generatione, & Corruptione*. Romae: Michaelis Herculis. Sumptibus Federici Franzini (FSLJ-7 e 51 (10 h 7) with volumes 2 and 3 bind in cover of Semery's book; Auersperg's book).
- Mauro, Silvestro. 1668. *Aristotelis opera quae exstant omnia, brevi paraphrasi, ac litterae perpetuo inhaerente explanatione illustrata a P. Sylvestro Mauro, Societatis Iesu*. 1–6. Romae: Angelo Bernabò & Federico Franzini (NUK-606 from Karl Peer's heritage; Auersperg's book; KSSKL-Loka S 4, 5; FSLJ-2 b 55-60 (1 left h 1/2 d 26)).
- Mayr, Janez Baptist (Johann Mayer the Viennese, * 1693); Joseph Mathias Prešeren von Heldenfeld (Hraše) by Radovljica (Matija Presheren). 1728. *Idea sapientis Theo - Politici, seu tripartita morum philosophia ethica politica, oeconomica, summaria methodo comprehensa, problematicis quasitis, et emblematis illustrata, dum In archi - Ducali & Academico Societatis Jesu Gymnasio Labaci Philosophiam suam publice propugnaret, eruditus ac perdoctus dominus Josephus Mathias Preschern, Carniolus Rottmansdorffensis Praeside R. P. Joanne Bap. Mayr*. Dedicated to the deceased Ljubljana Provost's relative and namesake Janez Krstnik Presheren). Vienna: widow Maria Teresia Voigt (FSLJ-5 D 21; NUK-GS 0 21065; NUK-GS I 21064; NUK-GS 0 4423, one of them bind to: 1724. *Idea sapientis i. e. Philosophicae Morum Pars prima Ethica summaria methodo comprehensa, Problematicis quaesitis et Emblematis ilustrata etc*. Vienna: widow Maria Teresia Voigt (NUK-GS 9487)).
- Mayer, Daniel. 1996. Nikola Tesla in Prague in 1880 – some details from Tesla's life, until now unpublished. *Tesla III Millennium. Fifth International Conference*. Beograd, pp. VI/67–VI/69.
- Mayer, James Walter; Eriksson, Lennart; Davies, John Arthur. 1970. *Ion implantation in semiconductors, silicon and germanium*. New York: Academic Press.
- Mayr, Janez Krstnik (Joannis Baptistae). 1678. *Catalogus Librorum qui Nundinis Labacensibus Autumnalibus in Officina Libraria Joannis Baptistae Mayr*. Venales prostant. Labaci (Ljubljana): Mayr. Facsimile Reprint: 1966. Ljubljana: National Museum.
- Maxwell, James Clerk. 1873. *Treatise on Electricity and Magnetism*. 1-2. Oxford: Clarendon Press.
- Maxwell, James Clerk. 1879. On stresses in rarefied gases arising from inequalities of temperature. *Phil. Trans.* 170: 231-256.
- McLeod, Herbert G. 1874. Apparatus for the measurement of low pressure of gas. *Phil. Mag.* 48: 110-112.
- Meadows, Donella H.; Meadows, Dennis, L.; Randers, Jorgen (Jørgen); Behrens, William W. 1972. *The Limits to Growth*. New York: Universe Books.
- Mecenseffy, Grete. 1938. Im Dienste dreier Habsburger. Leben und Werken des Johann Weikhard Auersperg (1618-1677). *Archiv für Österreichische Geschichte*. 114/2: 295-509.
- Mecenseffy, Grete. 1955. Habsburger im 17. Jahrhundert. Die Beziehungen der Höff von Wien und Madrid während des dreissigjährigen Krieges. *Archiv für Österreichische Geschichte*. 121/1: 1-91.
- Medica, Vladimir. 2011. Peter Salcher and Optical Research Methods. *Peter Salcher & Ernst Mach* (ed. Franković, Bernard; Pohl, Gerhard), Zagreb: HAZU. 309–325.

Megiser, Hieronymus. 1612-1614, *Theatri Machinarum*. Leipzig: Henning Grosse junior. Volumes 4-6 as addition to first three volumes published up to 1612 as H. Zeising's work as Megiser's translation based on Agostino Ramelli's book of 1588 and other sources. Fifth volume: 1614. *Theatri Machinarum fünffter (fünfter) Theill. Auch zum beschlüs etliche Frücht mitt Springwergk zübefinden, Sampt ihren zugeherigen Visirungen. Auch zum beschlüs etliche Frücht mitt Springwergk zübefinden, Sampt ihren zugeherigen Visirungen*. Leiptzig: Grosse. Dedication signed by the editor-printer Grosse on 2 September 1613: *Dem Edlen/ Ehrenvesten und Manhafften/ Herrn Hans Georg Triglern von Iglerraw/ Hauptmann der Herrschafft Güldenstein/ [et]c. Meinem besonders günstigen Herrn und vertrawtem Freunde*.

Meitner, Lise. 1922. Über die Entstehung der β -Strahl-Spektren radioaktiver Substanzen (About the Entente of the β -rays Spectres of radioactive Substances). *Z. Phys.* 9: 131-144.

Meitner, Lise. 1922. Über den Zusammenhang zwischen β - und γ -Strahlen. *Z. Phys.* 9: 145-152.

Meitner, Lise. 1922. Über die β -Strahl-Spektren und ihren Zusammenhang mit der γ -Strahlung (About the β -rays Spectra and their context with the γ -rays). *Z. Phys.* 11: 35-54.

Meitner, Lise. 1923. Das beta-Strahlenspektrum von UX1 und seine Deutung. *Z. Phys.* 17: 54-66.

Melanchthon, Philipus; Euclid. 1537/1546, *Elementorum (geometricum libri XV), interpreta Barth Zamberto Veneto, cum expositione Theonis in priores XIII a Barth (Zamberto) & Campanus da Novara & Hypsiclis*, Basileae: Hervagius.

Melanchthon, Philipus. 1560. *Initia doctrinae physicae dictata in Academia Viterbergensi*. Leipzig: Rhambaw.

Mendelssohn, Kurt. 1966. *The quest for absolute zero: the meaning of low temperature physics*. New York: McGraw-Hill / London: Weidenfeld and Nicolson. Second edition: 1977. *The Quest for Absolute Zero*. London: Taylor & Francis LTD / New York: Halsted Press.

Mendoca (Mendoza, Medoza, Mendonça), Francisco de. 1628. Coimbra?. Reprint: 1701. *Viridarium utrisque eruditionis sacrae et profanae (Viridarium sacrae ac profanae eruditionis)*... à P. Francisco de Mendoca Olisiponensi, Societat. Jesu doct. theolog. olim in Conimbricensi Academia primario eloquentiae magistro. Coloniae Agrippinae (Köln): Jacob Promper (FSLJ- 4 d 16/18 d 16).

Menner, Johann G. (Ivan Nepomuk Menner, Joann Maenner, Johann Gregor Manner, Männer). 1824. *Positiones ex geometria quas in regia scientiarum Academia Zagrabienensi die 22. Augusti 1824. publice propugnandas susceperunt ... domini Chachkovich Ladislaus, Domin Ignatius, ... [E praelectionibus Joan. Nep. Maenner, ...]*. Zagreb.

Menner, Johann G. (Ivan Nepomuk Menner, Joann Maenner, Manner, Männer). 1835. *Tentamen publicum ex algebra et geometria, quod in regia scientiarum Academia Zagrabienensi anno MDCCCXXXV mense Julio subivit r.d. Rubido Antonius, ... [E praelectionibus Joannis Nep. Maenner, ...]*. Zagreb.

Merinero, Joannes (Joan). 1659. *Commentariorum in octo libros Aristotelis de Physico auditu... Cursus Integer philosophia juxta Subtilis doctoris Duns Scoti mentem...* Contains: volume 1: *Commentarii in universam Aristotelis Dialecticam iuxta Subtilis Doctoris Ioannis Duns Scoti mentem*; volume 2: *Tomus prior Commentariorum in octo libros Aristotelis De Physico auditu, seu auscultatione : continens duos priores libros, una cum disputationibus, et quaestionibus, hoc tempore agitari solitis, iuxta subtilis Doctoris Ioannis Duns Scoti mentem*; volume 3: *Tomus posterior Commentariorum in octo libros Aristotelis de physico auditu, seu auscultatione : continens sex posteriores libros, una cum disputationibus, et quaestionibus hoc tempore agitari solitis iuxta Subtilis Doctoris Ioannis Duns Scoti mentem*; volume 4: *Commentarii in duos libros Aristotelis de ortu, et interitu rerum, seu de generatione, et corruptione earum, iuxta Subtilis Doctoris Ioannis Duns Scoti mentem, una cum disputationibus, et quaestionibus, hoc tempore, agitari solitis*; volume 5: *Commentarii in tres libros Aristotelis de anima, iuxta Subtilis Doctoris Ioannis Duns Scoti mentem, una cum disputationibus, et quaestionibus, hoc*

tempore agitari soliti. Madriti: Matheum Fernandez typographo Regium (FSLJ-2 g 21-25, propriety entries: Ljubljana Franciscan Marci Brenn and after him Paul Budimir).

Methuen, Charlotte. 1998. *Kepler's Tübingen: Stimulus to a theological mathematics*. Aldershot: Ashgate.

Metzburg, Georg Ignatz. 1769. *Clarissimi Helshami, in Universitate Dublinens philosophiae naturalis professoris, Physica experimentalis Newtoniana: ex editione tertia Londinensi Anglica in Latinum translata*. Vindobonae: Joan. Thomae Trattnern.

Metzburg, Georg Ingatz. 1773. Exam theses as appendix of *Dissertatio de aquae* of his colleague professor Joseph Edler Herbert. Vienna: Thoma Trattnern.

Metzburg, Georg Ingatz. 1775, 1776, 1777. *Institutiones Mathematicae in usum Tironium conscriptae*. 1–3. Viennae: Typis Joan. Thomae Trattnern. I–V. (Erberg-M41; NUK-4281). Reprint of third part bound to the exam of Malachio Zeman on 12 August 1777. *Praxis geometrica ex principiis trigonometricis deducta*. Vienna: Trattnern. Reprint: 1780. Viennae: Trattnern (NUK-4069). Reprint with 4 parts added - in seven parts, bind in three books: 1792–1793. Translation of A., X. G. (= Franz Xavier G. Arming): 1798–1804. *Anleitung zur Mathematik*. Wien: Franz Joseph Rötzel (& Anton Gassler & Ignatz Alberti's widow Anna). I–VII (Erberg-M42; NUK-4281; FSLJ-14 d 32).

Meyer, Kirstine (born Bjerrum). 1909. *Temperaturbegrebets Udvikling gennem Tiderne (The Development of the Temperature Concept through Time)*. Ph.D. dissertation. København: J. Gjellerup. German translation: 1913. *Die Entwicklung des Temperaturbegriffes im Laufe der Zeiten*, Braunschweig: Vieweg.

Meyer, Wilhelm Heinrich Theodor. 1857. *Bestimmungen über die intensität des freien magnetismus in künstlichen magneten, nebst untersuchungen über coërcitivkraft*. Marburg.

Meyer, Wilhelm Heinrich Theodor. 1858. *Beobachtungen über das Geschichtete electriche*

Licht sowie über den merkwürdigen Einfluss des Magneten auf dasselbe nebst Anleitung zur experimentellen Darstellung der fraglichen Erscheinungen. Berlin: Julius Springer.

Meyer (Mayr, Mayer), Wolfgang Augustin. 1680. *Lust, Luft, und Feuer Kunst, aus welcher ohne sondern Kosten und Mühe zu erlangen, wie Man Schwärmen groß und kleine Regatten, Pumpen und Masculen Stöcke groß und kleine auf Regattenwerfender zurichten solle. Sambt dann beygefügtten allerhand Materien, und ihren zusammengesetzten ordentlichen Dosen und Massen. Wie solchen alles punctualier aus denen beigefügte und volle druck 38 Figuren*. In octavo. Ulm: Schultes (ST-22/83 109^v; W-1540; NUK »Bibliotheca Sitticensi insertus«).

Micelli, Francesco. 2004. Gianrinaldo Carli e la spedizione degli Argonauti. Gianrinaldo Carli nella cultura europea del suo tempo (ed. Trampus, Antonio). *Quaderni Giuliani di Storia*. Trieste. Anno XXV: 173-183.

Middleton, William Edgar Knowles. 1964. *The history of the barometer*. Baltimore: The Johns Hopkins Press

Mihály, Dénes von. 1930. Über die Synchronisierung elektrischer Fernsehapparate (On the synchronization of electric television apparatus). *Fernsehen*. 1 (January): 19-22, 52-57.

Mikkeli, Heikki. 1992. *An Aristotelian response to Renaissance humanism: Jacopo Zabarella on the nature of arts and sciences*. PhD dissertation at Helsinki university, Helsinki: Societas Historica Finlandiae.

Miklavčič, Maks. 1967. Seebach (Sepach, Sepacher) Peter (keyword). *SBL*, 3/10: pp. 268–269.

Miklavčič, Maks. 1967. Skerpin (Škrpin) Žiga (keyword). *SBL*. 3/10: p. 329.

Mikšić, Marko. 1883. *Meteorologička opažanja. Godišnje izvješće Kralj. velike realne gimnasije u Rakovcu u Hrvatskoj za školsku godinu 1882/3 (Program realne gimn. u Rakovcu g. 1883)*. Zagreb:

- C. Albrecht, two tables inserted between pages 16-17.
- Millikan, Robert Andrews; Fletcher, Harvey. 1911. The Question of Valency in Gaseous Ionization. *Physical Review* (Series I) 32/2: 239.
- Millikan, Robert Andrews; Fletcher, Harvey. 1911. On the question of valency in gaseous ionization. *The London, Edinburgh, and Dublin Philosophical Magazine and Journal of Science*, 21/126: 753-770.
- Millikan, Robert Andrews. 1963. *The Electron*. Chicago & London: The University of Chicago Press.
- Milton, John. 1667. *Paradise Lost*. Translation of Luca Andrea Corner: 1803. *Del Paradiso perduto di Giovanni Milton / versione libera poetica dall'inglese di Luc'Andrea Corner*. Venezia: Luc'Andrea Corner's self-publishing (POMPI). Translation of Giovanni Francesco Cuneo d'Ornano: 1822. *Il Paradiso perduto di Gio. Milton tradotto dal padre G.F. Cuneo d'Ornano ... con prefazione e note di Mr. C. D'O. editore*. 1-2. Rome.
- Minařik, Franc. 2000, 2001. *Minařikova Zbrana dela*. Uredil Štefan Predin. Maribor: Mariborske lekarne.
- Mircevski (Mirčevski), Slobodan; Cundev, Milan; Andonov, Zdravko. 2007. Development of the Induction Motor from Tesla until Today, *Electronics*, 11: 20-24.
- Minck (Mink), Franz. 4 February 1896. Zur Frage über der Einwirkung der Röntgen'schen Strahlen auf Bacterien und ihre eventuelle therapeutische Verwendbarkeit. *Münchener Medicinische Wochenschrift Organ für amtliche und praktische Ärzte* (Munich). Volume 43/5: 101-102; 3 March 1896) 43/9: 202. X-rays did not appear to kill bacteria, as had been hoped, or even to limit their growth, but radiological damage of X-rays soon became evident with notes on Minck's boss Buchner's papers of 1892 and 1893, Hittorf's cathode ray tubes at Munich Physics Institute (Physikalischen Institute der Universität München), Eugen von Lommel and dr. Fromm. Note on Minck's work appeared 26 days after his publication: 2 March 1896. Local- und provincial-Nachrichten. Die Verwendung der Röntgen-Strahlen bei Infections Krankheiten (The use of X-rays against infections diseases, Uničevanje bacilov z rentgenskimi žarki). *Laibacher Zeitung* (Ljubljana). No. 51: 397.
- Mitrović, Jovan. July 15, 2012. Jožef Stefan and the dissolution-diffusion phenomena - Not only a historical note. *International Journal of Pharmaceutics*, 431/1-2: 12-15.
- Mitteis, Heinrich. Ueber Meteorologische Linien. 1854. (5th) *Programm und Jahresbericht des kaiserl. königl. Akademischen Gymnasium (Obergymnasiums) zu Laibach, für das Schuljahr 1854 (Reports of Grammar school. Izvestja Gimnazije)*, Laibach (Ljubljana): Druck von Ign. V. Kleinmayr & Fedor Bamberg, 3-8.
- Mitteis, Heinrich. 1856. Abbé Nollet in seiner Stellung gegen Benjamin Franklin. *Programm und Jahresbericht des kaiserl. königl. Obergymnasiums zu Laibach, Schuljahr 1856 (Laibach: Druck von Ign. V. Kleinmayr & Fedor Bamberg)*. 3-12.
- Mitteis, Heinrich. 1858. Lecture on Lightning (Predavanje o streli pri Muzejskem društvu) Ljubljana 2 January 1856. *Jahresheft des Vereins des Krainischen Landes-Museums*. 2: 88-89.
- Mladjenović (Mladenović), Milorad. 1985. *Razvoj fizike, Optika (Development of physics, optics)*. Beograd: IRO, Građevinska Knjiga (Builders' book).
- Mlakar, Gojmir. 1996. *Meje: posestne in državne*. Ljubljana: Inštitut za geodezijo in fotogrametrijo FGG.
- Mlakar, Jasna, 1998. Razvoj mariborskega vodovoda, *Zgodovina za vse*, 5/1: 5-20.
- Mlinar, Janez, 2016. Povednost srednjeveških urbarjev. Primer belopeškega urbarja iz leta 1498, *Urbarji na Slovenskem skozi stoletja* (ed. Bizjak, Matjaž; Žnidaršič Golec, Lilijana), Ljubljana: Arhiv Republike Slovenije.
- Mlinarič, Jože. 1982. *Kartuzija Pleterje 1403-1595*. Pleterje: Kartuzija.

Mlinarič, Jože. 1995. *Stiška opatija 1136-1784*. Novo mesto: Dolenjska založba.

Młodzianowski, Thomas (Tomasz Młodzianowski SJ). 1671. *Praelectiones philosophicae in octo libris physicorum pris Thomae Młodzianowski: insertae sunt et quaestiones magis disputabiles de coelo et mundo*. Lesnae (Leśna south-western Polish Lower Silesia near Czech border): Imprimebat Michael Buck. Second edition: 1682. *R.P. Thomae Młodzianowski ... Praelectionum theologiarum tomus primus [-quintus] ... 5, R.P. Thomae Młodzianowski... Praelectiones philosophicae sive Operum tomus quintus de metaphysica, logica, octo libris physicorum, generatione, corruptione et anima*. 1-2. Mainz & Danzig (Moguntiae et Dantisci): Simonis Beckensteinios (FSLJ-11 k 36-37, exlibris Ludovic a Gallenfels; pro bibl. Labaci).

Monardes, Nicolò (Nicolau Monardis). 1547. *Primera, segunda y tercera partes de la historia medicinal de las cosas que se traen de nuestras Indias Occidentales ... que siruen en medicina ... van en esta impresión la tercera parte y el diálogo del hierro nueuamente hechos, que no han sido impressos hasta agora*. Sevilla: Alonso Escriano. Reprints: 1565. *Dos libros, el vno que trata de todas las cosas que traen de nuestras Indias Occidentales, que siruen al uso de la medicina, y el otro que trata de la piedra beazaar, y de la yerua escuerçonera*. Sevilla: Sebastian Trugillo; 1569-1571. *Historia medicinal. Pts. 1-2. Dos libros, el uno que trata de todas las cosas que traen de nuestras Indias Occidentales que siruen al uso de la medicina y el otro que trata de la piedra beazaar*. Sevilla: Hernando Diaz. Abridged Latin Translation of Charles de L'Écluse (Carolus Clusius): 1574. *Nicolau Monardis, hispanensi medico, De simplicibus medicamentis ex occidentali India delatis, quorum in medicina usus est, auctore D. Nicolao Monardis, ... interprete Carolo Clusio*. Antverpiae: Christophor Plantin (NUK- GS 11528, bind to: don Horto (Orta), G. dall', Clusius, C., Monardes, N., Briganti, Annibale. (translator). 1582. *Due libri dell'istoria dei semplici, aromati et altre cose; che vengono portate dall'Indie Orientali pertinenti all'uso della medicina di don Garzia Medico Portoghese con alcune brevi annotazioni di Carlo Clusio. Et due altri libri parimente quelle che si portano dall'Indie Occidentali di Nicolò*

Monardes, Medico di Sinigalia Tradotti nella lingua Italiana da M. Annibale Briganti Maruccino - Dottore et medico, Venetia: Heredi di Francesco Ziletti (Stična book, now NUK-11819)). Reprint of Italian translation of Briganti, Annibale: Clusius, Carolus; Monardes, Nicolò. 1589. *Dell'istoria dei semplici aromati, et altre cose; che vengono portate dall'Indie Orientali pertinenti all'uso della medicina: parte prima: divisa in libri IIII*, Due libri in 8to. Venetia: Heredi di Francesco Ziletti (Auersperg's book).

Montanari, Geminiano. 1696. Instruzione scritta già tempo al N. H Sier Pietro Grimani dal Signor Dottor Geminiano Montamari &c. sopra il modo di conoscere la differenza del peso de fluidi frà loro, e de solidi colla maniera di cui egli si serviva per indagare tali differenza trà (tra) liquore, e liquore, e trà (tra) solido, e solido, pesato nel acqua (in folio), *La galleria di Minerva o vero notizie universali*, Venezia: edited and printed by Girolamo Albrizzi, 1: 390-394.

Monte, Guido Ubaldo marquis del. 1577. *Guido Ubaldi e' marchionibus Montis Mechanicorum liber: in quo haec continentur De libra, De vecte, De trochlea, De axe in peritrochio, De cuneo, De cohlea*. Pisauri (Pesaro): Hieronim (Girolamo) Concordia (Auerspergova ljubljanska library; 130 folios; 33 cm). Reprints: 1579; 1615. *Le mecaniche*. Venetiis: Evangelista Dechino (Sumitomo library); 1629. *Mechanischer Kunst-Kammer... überztztz Danielem Mögling Wirtemb...* Franckfurt: Merian (Valvasor's library). Monteggia, Giovanni Battista. 1794. *Annotazioni pratiche sopra i mali venerei*. Milano: Giuseppe Galeazzi. Reprint: 1796. Napoli: Fratelli Marotta.

Montgomery, Scott L. 2000. *Science in Translation*. Chicago: University Press.

Moore, Gordon E. January 1998. The Role of Faichild in Silicon Technology in the Early Days of Silicon Valley. *Proc. IEEE*. 86/1: 53-62.

Morishima, Chūryō. 1787. *Kōmō zatsuwa* (紅毛雜話, Nizozemske različnosti, The differences of Netherlands). Yedo (Edo, now Tokyo), English abstract of Masujiro Honda read before the Japan

Society of London on 10 February 1909. 1909. Komo zatsuwa, or the red-hair miscellany. *Transactions and Proceedings of Japan Society London*. 1907, 1908, 1909. 8: 229-245.

Moroškin, Mihail Jakovlevič. 1867. *Iezuiti v Rossii: s carstvovanija Ekaterini II-i i do našego vremena. Čast I*. Sankt-Peterburg: E. I. V. Kancelari. Reprint: 1888. Peterburg: Tipografija tovariščestva “Obščestvennaja Poljza”.

Morselli, Mario. 1984. *Amedeo Avogadro (1776-1856). A Scientific Biography*. Dordrecht: D. Reidel Publishing Company.

Moser, Josip. 2017. Potjera za Teslinim nestalim rukopisima. Je li Tesla pronašao zrake smrti? (The pursuit of Tesla's missing manuscripts. Did Tesla find the rays of death?) *Povijest i filozofija tehnike / radovi EDZ sekcije 2012. - 2016. godine (History and philosophy of technology - works of the EDZ (Elektrotehničko društvo Zagreb) section from 2012 to 2016)*, (ed. Benčić, Zvonko; Moser, Josip). Zagreb: Kiklos – krug knjige d.o.o., pp. 3-21.

Mrkić, Dan. 2002. Nikola Tesla. *American Srbobran*, Pittsburgh, March 20-May 15, 2002; Nov. 6, 2002-Jan. 7, 2003; and May 7-July 2, 2003. Republished: 2003. *Nikola Tesla - the European Years*, Ottawa: Commoners' Publishing. Translation: 2004. *Nikola Tesla – europske godine*. Beograd: Muzej Nikole Tesle.

Muljević, Vladimir. 1973. Martin Sekulić (1833–1905). *Elektrotehnika: znanstveno-stručan časopis Hrvatskoga elektroinženjerskog saveza i udruženih izdavača*. 5: 331–338.

Müller, Johann Christoph. 1720. *Mappa Geographica Regni Bohemiae. In duodecim circulos divisae cum Comitatu Glacensi et Districtu Egerano adiunctis circumiacentium regionum partibus conterminis ex accurata totius Regni perlustratione et geometrica dimensione omnibus, ut par est, numeris absoluta et ad usum commodum nec non omnia singula distinctius cognoscenda XXV. sectionibus exhibita / à Joh. Christoph Müller, S.C.M. Capitan et Ingen.; Michael Kauffer sculpsit Mappam; Wenceslaus Laurentius Reinner invenit et*

delineavit; Iohann Daniel Hertz sculpsit. Augsburg/Prague: Michael Kauffer.

Müllner, Alfons. 1901. Die Realistischen Disciplinen am Laibacher Jesuiten - Collegium. *Argo* 9: pp. 171–172.

Münster, Sebastian. 1533. *Horologiographia post priorem aeditionem per Sebast. Musterum recognita, & plurimum aucta atc & locupletati, adiectis multis novis descriptionibus & figuris, in plano, concavo, convexo, erecta superficie & c.* Basileae: Henric Petri (Henricus Petrus) (NUK-4331). Translation: 1538. *Fürmalung und künstlich Beschreibung der Horologien...* Basileae: Henric Petri (ST-21/83 99^v; NUK-7924).

Murko, Vladimir. 1974. Starejši slovenski znanstveniki in njihova vloga v evropski kulturni zgodovini – Astronomi (Elder Slovenian scientists in European history – Astronomers), *Zbornik za zgodovino naravoslovja in tehnike (Anthology for history of Science and technology)*. Ljubljana: Slovenska Matica, 2: 11-42.

Murovec, Barbara, Klemenčič, Matej, Breščak, Mateja (editors). 2005. *Almanach in slikarstvo druge polovice 17. stoletja na Kranjskem*. Ljubljana: ZRC SAZU.

Musschenbroek, Pieter van. 1729. *Physicae Experimentalis et Geometricae, de Magnete, Tuborum capillarum vitreorumque speculorum attractione, magnitudine terrae, cohaerentia corporum firmorum dissertationes: ut et ephemerides meteorologicae ultrajectinae*, Lugduni (Leyden): Samuel Luchtman (NUK-8458). Reprint of first part: 1754. *Petri van Musschenbroek Dissertatio physica experimentalis de magnete, quam cum assertionibus ex universa philosophia palam propugnatis Illustrissimus ac Perdoctus Dominus Bernardinus e Dominis ab Hochenwarth, Carniolus Gerlachsteinensis, philosophiae in 2. Annum auditor, praeside r. p. Bernardino Erber è S. J. Philosophiae Professore Publ. & Ord. In aula academica archiducalis Soc. Jesu colegii Labaci mense Sept. Anno 1754 utilitati publicae dedit*, Labaci: Reichhardt (Erberg; NMLJ-1834; NUK-8350; FSLJ-11 c 13). Reprint of all five parts: 1756. Vienna & Pragae & Tergesti: Thomae Trattner.

Musschenbroek, Pieter van. 1734. *Elementa Physicae conscripta in usus academicos*. Leyden: Samuel Luchtman; Reprints and translations: 1739. *Elementa physicae conscripta in usus academicos a Petro van Musschenbroek*. Leyden: Luchtman; 1739. *Mr. Pierre van Musschenbroek, Essai de physique, avec une description de nouvelles sortes de machines pneumatiques, et un Recueil d'expériences. Traduit en français par Pierre Massuet*. Leyden: Luchtman (NUK-8463). 1745. *Elementa physicae*, Venetiis: Giovanni Battista Recurti (FSNM; FSLJ-12 d 4); 1752. Recurti, Venetiis; 1761... *accedunt ubique auctaria quamplurima, frequentissimae adnotationes Disputatio physico-Historica de rerum corporearum origine, ac demum de rebus Caelestibus Tractatus. Opera et studio Antonii Genuensis... Editio Tertia Veneta Ad nouissimam Neapolitanam exacta, atque multis emendate atque aucta*. Venice: Remondiani; 1774... *editio Quarta Veneta...* Bassano/Venice: Remondini.

Musschenbroek, Pieter van. 1748. *Institutiones physicae*. Leyden: Samuel Luchtman & sons (MINSPT).

Musschenbroek, Pieter van. 1762. *Introductio ad philosophiam naturalem*. Leyden. Reprint: 1768. Padua: Joanne Manfrè (POMPI).

Mušević, Igor; Blinc, Robert; Žekš, Boštjan. 2000. *The Physics of Ferroelectrics and Antiferroelectrics Liquid Crystals*. Singapore: World Scientific.

Mušič, Drago. 1938. Iz zgodovine medicine na Dolenjskem (From the history of medicine in Lower Carniola), in: *Medical examiner (Zdravniški Vestnik: glasilo slovenskega zdravništva)*, Ljubljana: Slovensko zdravniško društvo, 10/12: 437-455.

Nagler, Josef (ed.). 1953. *Nikola Tesla-Kongress für Wechsel- und Drehstromtechnik, Technisches Museum für Industrie und Gewerbe in Wien, Forschungsinstitut für Technikgeschichte* (Blätter für Technikgeschichte, Sonderheft (Journal for the history of technique, separate inprint)). Held on 6th to 13th September 1953, Wien: Springer.

Nahrwold, Robert. 1888. Ueber die Elektrizitätsentwicklung an einen Glühenden Platindrahte. *Ann. Phys.* 35: 107-121.

Naji, Ali; Sarabadani, Jalal; Dean, David S.; Podgornik, Rudolf. 2012. Sample-to-sample torque fluctuations in a system of coaxial randomly charged surfaces. *Eur. Phys. J. E (European Physical Journal E: Soft matter and biological physics, EDP Sciences)*, 35/3: 24 (pp. 1-7).

Nakamura, Tsuko. 2009. Shogunal Astronomer Takahashi Yoshitoki: His Life, Achievements and Influence. *Kagakusi Kenkyu (Journal of History of Science, Japan)*. 48/251: 156-161.

Nakayama, Shigeru. 2009. *Collected Papers of Shigeru Nakayama: The Orientation of Science and Technology: A Japanese View*. Kent: Global Oriental.

Nardin, Julius. 1929. Težave z iznajdbo (Problems with the invention). *Odmevi: literarno-kulturna revija (Echoes)*. 1/4: 43-48.

Natek, Milan. 1988. Zemljiško-posestna, socialna in zgradbena podoba Vranskega v 19. stoletju. *Savinjski Zbornik (Savinja River Valley anthology VI)* (ed. Kobale, Rezika). Maribor: Večer. 328-339.

Natterer Johann August. 1844. Stickstoffoxydul in freier Luft im flüssigen und festen Zustande dargestellt. *Pogg. Ann.* 62: 132-135.

Natterer, Johann August. 1850. Gasverdichtungs-Versuche. *Wien. Ber.* 5: 315-358.

Natterer, Johann August. 1851. Ueber Gasverdichtungs-Versuche. *Wien. Ber.* 6: 557-570.

Natterer, Johann August. 1854. Gasverdichtungs-Versuche. *Wien. Ber.* 12: 199-208. Reprint: 1855. *Pogg. Ann.* 94: 436.

Navinšek, Boris. 2000. Od reaktorskih materialov do površinskega naparivanja. *Pripovedi o IJS* (Osredkar, Milan; Polenec, Natalija (eds.)). 160-164.

Needham, Joseph; Ling, Wang. 1959. *Science and Civilization in China. Vol. 3. Mathematics,*

Astronomy, Geography, Cartography, Geology, Seismology and Mineralogy. Cambridge: Cambridge University Press.

Nemevšek, Miha. 2013. Vacuum, Colliders, and the Origin of Mass. *The Structure of the Void* (ed. Mladen Dolar; Gregor Moder; Aleš Bunta; Matjaž Ličer; Sašo Dolenc). *Filozofski vestnik*, 2013, 34/2: 79-96.

Nemevšek, Miha; Senjanović, Goran; Tello, Vladimir. November 2012/26 February 2013. Connecting Dirac and Majorana Neutrino Mass Matrices in the Minimal Left-Right Symmetric Model. *Phys.Rev.Lett.* 110/15: 151802 (6 pages).

Neumann, Johan Philip (Philipp). 1808-1812. *Compendiaria Physica Instituto in usum tironum conscripta (conscriptis) hujusque scientiae statui recentissimo accomodavit Joann. Phil. Neumann. Cum 3 figuris. Graecii: Franciscus Ferstl, 1-3 (Zois's library noted in Catalogus NUK Ms. 667 later NUK-8215 borrowed in the year 1966 but today lost; FSNM; FSLJ-19 h 41). Revised translation: 1818-1820. *Lehrbuch der Physik*. 1-2. 12 copperplates. Wien: Gerold (NUK-8514). Revised reprint: 1830-1835. *Handbuch der Physik*. 1-2. Wien: Carl Gerold's Sohn. Reprint: 1842. *Handbuch der Physik für Unterricht und Selbstbelehrung [mit immerwährender Beziehung auf Anwendung] Dritte ... ungestaltete Auflage (3rd edition using the volume 2 of the second edition of 1835). Bd 1, Wien: C. Gerold.**

Newton, Isaac. 1687. *Philosophiae Naturalis Principia Mathematica. Autore Is. Newton, Trin. Coll. Cantab. Soc. Matheseos Professore Lucassiano, & Societatis Regalis Sodali. Imprimatur. S. Pepys, Reg. Soc. Praeses. Julii 5. 1686*. Londini: Steater. Reprint: 1739-1742. (ed. Le Seur, Thomas; Jacquier, François). Genevae: Barrillot (FSNM).

Newton, Isaac. 1704. *Opticks*. London; 1718. London. Samuel Clarke's Latin translation: 1747. *Isaaci Newtoni Optices libri tres: accedunt ejusdem lectiones opticae, et opuscula omnia ad lucemet colores pertinentia, sumta ex transactionibus philosophicis*. Graecii: Widmanstetter /Venezia: Manfrè (FSKA).

Nichols, Richard. 1999. *Robert Hooke and the Royal Society*. Sussex, England: The Book Guild Ltd.

Nicolaus from Lucca; Ludwig (Ludovico) from Salice (Corsica or Apulia in Southern Italy); Kraus, Eginio (translator). 1976. *Leben und Taten des Valeriano Magni O.F.F. Cap*. Würzburg.

Nielson, Jens Rud. Memories of Niels Bohr. *Physics Today*, 16/10: 22-30.

Nielsen, Keld. 1989, 1991. Another kind of light: The work of T.J. Seebeck and his collaboration with Goethe, Parts I-II, *HSPS*, 20/1: 107-178; 21/2: 317-397.

Njegovan. Vladimir N. *Nikola Tesla: heroj tehnike*, 1950. Zagreb: Prosvjeta. Extended Reprint: 1956. *Nikola Tesla: 1856-1956. Izdanje Državnog republičkog odbora za proslavu stogodišnjice rođenja Nikole Tesle*, Zagreb: Prosvjeta.

Nollet, Jean Antoine. 1735. *Cours*. Paris: P.-G. Le Mercier; 1738. *Programme ou Idée générale d'un cours de physique expérimentale, avec un catalogue raisonné des instrumens qui servent aux expériences*. Paris: P.-G. Le Mercier; Changed title: 1743. *Leçons de physique experimentale*. Parts 1-4, Paris: Freres Guerin. Reprint: 1744. *Leçons de physique experimentale*. Parts 1-2, 2nd edition, Paris: Freres Guerin (FSLJ-6 g 41-42 with propriety entry "annotatio P. Ivo Bonelli"). Reprint: 1753-1764. In 6 parts (Zois' book now NUK-8259). Italian Translations: 1746. *Lezioni di Fisica sperimentale del sig. abate Nollet, dell'Accademia reale delle Scienze, e della Real Societa di Londra, tradotte dal francese*. 1-4. Venezia: Giambatista Pasquali (W-1545 acquired by the Jesuits in 1751 with propriety entry "Inscr. Cat. Coll. labacensis 1751 Bibl. Philo." now NUK-8247); 1751. *Lezioni di fisica sperimentale del signor abate Nollet ... tradotte dal francese. Tomo secondo..* Venezia: Giovanni Battista (Giambatista) Pasquali (POMPI; FSLJ-3 g 66-69 with propriety entry "ad usum Vincentio Mariaschitz procuratoris").

Nollet, Jean Antoine. 1740. Mémoire qui sont propres aux expériences de l'air. Seconde partie, De la construction d'une nouvelle machine pneumatique de raréfaction à deux corps de pompes. *Mémoires de*

l'Académie royale des sciences (Histoire de l'Académie royale des sciences, avec les mémoires de mathématique et de physique), Paris: Académie Royale. pp. 567-585.

Norris, John. 2000. *Artillery. A History*. Stroud/Gloucestershire: Sutton Publishers.

Nučič, Črtomir. 1964. Kemija (Chemistry). *Slovenian Matica 1864-1964*. (ed. France Bernik). Ljubljana: Slovenska Matica (Slovenian Queen Bee). 307-333.

Nye, David E. 1983. *The Invented Self. An Anti-biography, from documents by Thomas A. Edison*. Odense (Denmark): University Press.

Obermayer, Albert von. 1893. *Zur Erinnerung an Josef Stefan*. Vienna/Leipzig: Wilhelm Braumüller.

Obrul, Robert. 2003. Športno življenje v Mariboru do 1. svetovne vojne (Sports Life in Maribor prior to the First World War), *Studia historica slovenica*, 3/2-3: 373-419.

Oehrlein, Gottlieb S. 1986. Reactive-ion etching, *Phys. Today* (October 1986) 39/10: 26-33.

Ogonowski, Zbigniew. 1979. *Filozofia i mysl społeczna XVII wieku*. Warszawa: Państwowe Wydawn Naukowe.

Ogris, Alfred. 1982. Jožef Stefan - ein berühmter Physiker aus Kärnten. In: *Kärntner Landesarchiv, Die Kärntner Landmannschaft* (Klagenfurt), Heft (volume) 10: 60-64.

Ohl, Russell Shoemaker. 1952. Properties of ionic bombarded crystals. *Bell. Syst. Techn. J.* 31/1: 104-121.

Ohmori, Minoru. 1963. A Study on the Rekishō Shinsho (=New Treatise on Astronomy). 1st part. *Nippon Kagakushi Gakkai (Japanese Studies in the History of Science)*. 2: 146-153.

Oldenburg, Henry. 1674, 1675. *Acta Philosophica Societatis Regiae in Anglia anni 1665-1669...* Amsterdam: Henrich Boom & Theodor Boom (V; NUK; Mayr's offer in Ljubljana in 1678).

Olson, Axel Ragnar; Hirst, Lester Larsen. 1929. A new differential pressure gage. *J. Am. Chem. Soc.* 51/8: 2378-2379 (1929).

Opfermann, Lucas; Adam Adolph Schöpfflein. 1748. *Wolfius male vindicatur, sive Confutatio Scripti infamis, quod ab Anonymo compositum, Author Speciminis trigonometriae ad fortificatoriam" applicatae, D. Adamus Adolphus Schöpfflein ... typis excudi curavit, sub titulo: Vindicae Christiani Wolfii, oppositae dissertationi mathematicae: in qua examinantur: An elementa mathescos Christiani Wolfii sola & abunde satisfaciant & etc...* Augustae et Wirceburgi: Martin Veith. 8°.

Orbellis (d'Orbellis. Dorbellus, d'Orbelle), Nicolo. 1485. *Compendium mathematicum*. Printed without noted place or date in Bologna. Revised reprint: 1494. *Compendium philosophiae secundum viam Scoti doctoris subtilissimi compilatum. Pars prima, Logice brevis expositio. Pars secunda, Cursus librorum philosophiae naturalis. Pars tertia, De metaphisica libris XII, et Ethicorum libri X, et de Mathematica / Compendium mathematicae Expositio compendiosa super physicam, de caelo et mundo, de generatione et corruptione, de anima, necnon et metaphysicam et ethicam Aristotelis. (Omnia s.tit. :) Cursus philosophiae naturalis secundum viam Scoti. Basileae: Michael Furter. Reprint: 1503. *Sūmule (=Sūmmule) philosophiae rationalis seu logica excellentissimi artiūū & (=et) theologia professore (magistri Nicolai) Dorbelli: & (secundum) in doctrinam doctoris subtilis Scoti /...incipit mathematica; Cursus librorum philosophiae naturalis venerabilis magistri Nicolai de Orbelli ordi(ni)s minoru[m] s[e]c[un]d[u]m (secundam) via[m] doctoris subtilis Scoti. Basileae: Jacob Wolff de Pforzheim & Michael Furter (FSLJ-10 g 57).**

Orožen, Ignacij, 1887. *Das Bisthum und die Diözese Lavant. Theil 6, Das Dekanat Drachenburg: mit den bis zum Jahre 1854 dazu gehörig gewesenen Seelsorgestationen, als: Peilenstein, Drachenburg, St. Peter in Fautsch, St. Maria in Zagorje, St. Anna in Prevorje, St. Margarethen im Markte Montpreis, St. Maria in Dobje, Hörberg, St. Peter unter Königsberg, St. Lorenzen in der Krajina (bei Wisell), St. Nikolaus in Felddorf, Windisch-Landsberg, Olimien und St. Valentin ob Süßenheim. Marburg*

(Maribor): self-publishing.

Orožen, Janko. 1974. *Zgodovina Celja in okolice 2. del (History of Celje and surroundings, 2nd part)*. Celje: Kulturna skupnost.

Osredkar, Milan; Stephenson, Richard Montgomery. 1957. A low-power, high-thermal-flux experimental nuclear reactor, Submitted by M. Osredkar to the Graduate Division of the College of Engineering in partial fulfilment of the requirements for the degree of Master of Nuclear Engineering at New York University, New York, September 1956. *Journal of Nuclear Energy* (1954) 5/2: 210-214.

Osredkar, Milan; Stephenson, Richard Montgomery. 1959. *The Inside-Out Reactor*. *Chem. Eng. Progr. Symposium Ser. (Chemical engineering progress symposium series abstracts)* 55/22: 17–18.

Osredkar, Milan; Polenec, Natalija (eds.). 2000. *Pripovedi o IJS*. Ljubljana: IJS.

Osredkar, Milan. 2000. Nastanek in prva desetletja IJS. (Osredkar, Milan; Polenec, Natalija (eds.)). *Pripovedi o IJS*. 19-69.

Ottowitz, Niko. 2010. *Jožef Stefan: utrinki iz njegovega življenja in dela ob 175-letnici rojstva / Jožef Stefan. Streiflichter aus seinem Leben und Werk – zum 175. Geburtstag*. Klagenfurt: Eigenverlag (Bundesgymnasium und Bundesrealgymnasium für Slowenien / Celovec: Zvezna Gimnazija in Zvezna Realna Gimnazija za Slovence). Bilingual edition.

Oviedo, Franciscus de. 1651. *R. P. Francisci de Oviedo Madritani S. J. Theologiae Professoris. Cursus philosophiens, ad unum corpus redactus. Tomos I et II. 2-da editio ab Authore aucta, et a pluribus quibus scatebat, mendis expurgata*. Lugduni (Leyden): Philipp Borde & Laurent Arnavd (Arnaud) & Claudius Rigavd (Rigaud) (NUK-GS 24162). Reprint as 3rd revised edition: 1663. *R.P. Francisci de Oviedo Madritani ... Cursus philosophicus, ad vnum corpus redactus, tomus primus [-II.]. ... 2, Philosophiae R.P. Francisci de Oviedo Madritani Societatis Iesu sacrae theologiae professoris tomus 2. Complectens libros De anima, et Metaphysicam* (2nd and 3rd edition dedicated to the

archbishop Allumgentia). Lugduni (Leyden): Philipp Borde & Laurent Arnavd (Arnaud) & Claudius Rigavd (Rigaud) (FSLJ-22 a 22).

Ozanam, Jacques. 1694. *Récréations mathématiques et physiques*, 2 vols, Paris. Revised by Montucla, Jean Etienne: 1778. Paris: Cl.-Ant. Jombert, 4 vols.

Ožura, Jože. 1995. Osilnica in dolina v preteklosti. *Osilniška dolina*, (1995), No. 4: pp. 9-11; (1995), No. 5: pp. 11-12; (1996), No. 6: pp. 10-11.

Paar, Vladimir. 2004. Nikola Tesla u fizici. *Zbornik radova posvećenih 60. obljetnici smrti Nikole Tesle 1856.-1943 (Anthology of Works dedicated to Tesla*, eds. Fleš, Dragutin & Mardešić, Sibe). Zagreb: Hrvatska akademija znanosti i umjetnosti (HAZU), Razred za matematične, fizičke i kemijske znanosti. 35-48.

Paccassi, Johann. 1784. *Abhandlung über die Bewegungen der Luftmaschine*. Wien: Trattner.

Pace, Stefano. 1718. *La fisica de' Peripatetici, Cartesiani ed Atomisti al paragone della vera Fisica d'Aristotele: dedicata al merito del N. H. Signor Antonio Scroffa* (the noble from Vicenza). Venezia: Antonio Bortoli. Reprints: 1729 Venezia: Lorenzo Basseggio; 1741 Venezia: Lorenzo Basseggio (J-414 and J-633, W-1547, now NUK-8413, Ex-libris: Inscriptus Catalogo Bibl. Phil. Coll. Labaci S.J. 1771 (College of philosophy Ljubljana)).

Sforza Pallavicino, later cardinal Francesco Maria Sforza (Pietro Pallavicini). 1625. *De universa philosophia a marchione Sfortia Pallauicino publice asserta in Collegio Romano Societ. Iesu libri tres ad Vrbanum 8. p.m.* dedicated to Pope Urban VIII and given to all cardinals present at the discussion of Pallavicino's PhD Dissertation in Rome after his studies with John de Lugo. The president of defence was a Jesuit father Vincenzo Araneam while the designs architectural with vignettes and coat of arms of Urban VIII were engraved by Camillo Congio. Romae: Franciscus Corbeletti (FSLJ-11 b 15).

Pancaldi, Giuliano. 2005. *Volta: Science and Culture in the age of Enlightenment*. Princeton, NJ: Princeton University Press.

Pančur, Andrej. 2007. Opis oderuhov v 19. stoletju na Slovenskem. *Acta Histriae*. 15/ 1: 179–194.

Panjan, Matjaž; Franz, Robert; Anders, André. 2014. Asymmetric particle fluxes from drifting ionization zones in sputtering magnetrons. *Plasma Sources Sci. Technol. (Plasma Sources Science and Technology)*. 23/2 (17 March 2014).

Panjan, Peter. 2001. Sinteza nanocevk MoS₂ – odmevno odkritje znanstvenikov z Instituta »Jožef Stefan«. *Vakuumist*. 21/2: 15-16.

Panjan, Peter. 2002. Prof. dr. Boris Navinšek – sedemdesetletnik. *Vakuumist*. 22/2-3: 43-45.

Panjan, Peter; Čekada, Miha; Panjan, Majaž; Paskvale Srečko; Kek-Merl, Darja. 2009. Pulzno magnetronsko naprševanje pri veliki vršni moči. *Vakuumist* 29/1-2: 31-36.

Panjan, Peter. 2011. Book Review: »Zgodovina raziskovanja vakuuma in vakuumskih tehnik« (2nd part). *Vakuumist*. 31/1: 35.

Papin, Denis. 1688. *La Manière d'amolir (=amollir) les Os, et de faire cuire toutes sortes de viandes en fort peu de temps, & à peu de frais. Avec Une description de la Machine dont il se faut servir pour cet effet, ses propriétés & ses usages, confirmez (=confirmez) par plusieurs Expériences (=Expériences)*. Amsterdam: Henry Desbordes.

Pärr, Nora. 2011. *Maximilian Hell und sein wissenschaftliches Umfeld im Wien des 18. Jahrhunderts*. PhD Dissertation at Viennese Philosophical Faculty. Vienna: Traugott Bautz GmbH.

Partsch, Paul Maria. 1826. *Bericht über das Detonations-Phänomen auf der Insel Meleda bey Ragusa*. Wien: Heubner.

Pascal, Blaise. 1648. *Récit de la Grande Expérience de l'équilibre des liqueurs, projectée par le sieur B. P. [Blaise Pascal] pour l'accomplissement du traité qu'il a promis dans son abrégé touchant le vuide, et faite par le sieur F. P. [Florent Perier] en une des plus hautes montagnes d'Auvergne*. Paris: Charles Savreux.

Paulin, Andrej; Trbižan, Milan. 1996. Zakaj je Valvasor lahko ulival tankostenske kipe iz medi. *Rudarsko-metalurški anthology*. 43/3-4: 261-269.

Paulin, Andrej. 1998. Metalurgija neželeznih kovin na Slovenskem. *Anthology za zgodovino naravoslovja in tehnike*. 13-14: 53-76.

Paušek-Baždar, Snježana. 1987. Josip Franjo Domin. In: Domin, 1987. Zagreb: JAZU. 113-129.

Paušek-Baždar, Snježana. 1994. *Flogistonska teorija u Hrvata*. Zagreb: HAZU.

Paušek-Baždar, Snježana. 2008. Königin Barbara zu Cilli als Alchimistin in Samobor (Kraljica Barbara Celjska kao alkemičarka u Samoboru). *Godišnjak Njemačke narodnostne zajednice (Society of German National Minority - Association of Danube Swabians Croatia, Osijek)* 15/1: 275-280.

Penning, Frans Michel. February 1937. Ein neues manometer für niedrige gasdrucke, insbesondere zwischen 10⁻³ und 10⁻⁵ mm. *Physica (Elsevier)*, 4/2: 71-75. Separate print: 1937. Eindhoven: Laboratory N.V. Philips' Gloeilampenfabrieken (Natuurkundig Laboratorium der N.V. Philips' Gloeilampenfabrieken Eindhoven-Holland, The Netherlands). Translations: 1937. High vacuum gauges. *Philips Tech. Rev.* 2: 202-203. Translated by A.F. Monypenny: 1937. New York: Macmillan, 75 pages.

Penning, Frans Michel. 1955. *Elektrische gasontladungen*. Den Haag: Servire. Previously translated by Andrew Francis Monypenny. 1937. *Electrical discharges in gases*. New York: Macmillan. Translated by Walter Feiner and Robert Scholz-van Kets: 1957. *Elektrische Gasentladungen*. Eindhoven, Holland: N.V. Philips' Gloeilampenfabrieken (Philips' technical library). Reprint of translation of A.F. Monypenny. 1957. *Electrical discharges in gases*. Eindhoven, Holland: N.V. Philips' Gloeilampenfabrieken (Philips' technical library).

Perrin, Jean Baptiste. 1927. *Les atomes*. Paris: Librairie Félix Alcan.

- Pertl, Eman. 1991. Zgodovina mariborskega zdravstva. *Maribor skozi stoletja, Razprave I* (ed: Curk, Jože). Maribor: Obzorja. 565–583.
- Pertot, Milan. 1962. *Nikola Tesla pionir elektriške dobe*. Ljubljana: Elektrogospodarska skupnost Slovenije.
- Petazzi, Adelmo Antonio count (of Novigrad, Adelmus Antonius Petazi di Castel Nuovo, Petaci, Petačić). 1723. *Responsio Cartesii ad regulam fidei et rationis in examen vocati a quodam auctore libelli notati Examen doctrinæ cartesianæ: breve opusculum quod Adelmus Antonius Sac. Rom. Imp. comes Petazi suæ majestati cæsareæ Josephi. Augustæ Vindelicorum (Augsburg): Daniel Walder (FSLJ-13 f 11).*
- Peterlin, Anton. 1946/47. Perpetuum mobile in »Impulzna teorija gibanja (recenzija knjige Marjana Čadeža Impulzna teorija gibanja: pojavi v ozračju kot slika pojavov v vesolju. 1945. Samozaložba (Perpetuum Mobile and the "pulse theory of motion" Book Review of Marjan Čadež's Pulse theory of movement, which occurs in the atmosphere as a picture of phenomena in the universe. Self-publishing.)). *Proteus*. 9: 17-19.
- Peterlin, Anton. May 1955. Das 31 MeV Betatron. *Reports*. 2: 53-59.
- Peterlin, Anton (ed.). 1956. *Radioaktivnost*. Ljubljana: Institut Jožef Stefan.
- Peterlin, Anton. 1956. Boiling Column Homogenous Research Reactor. *Bulletin Scientifique*. 3/2: 41.
- Peterlin, Anton. October 1956. Boiling Column Homogenous Reactor with Adjustable Reflector Level. *Reports*. 3: 19-30.
- Peterlin, Anton. 1957. Fizika reaktorja (predavanje na plenumu Zveze društev matematikov in fizikov Jugoslavije v Ljubljani, on 7 October 1956 (paper read in 1956)). *Nastava matematike i fizike (Beograd)*. 1: 1-14.
- Peterlin, Anton. 1957. Nekateri fizikalni in kemijski problemi homogenega reaktorja. *Vestnik slovenskega kemijskega društva*. 4/1-2: 57-63.
- Peterlin, Anton. 1959. Determination of Molecular Dimensions from Rheological Data. *Die makromolekulare Chemie (Heidelberg)*. 34/1: 89-119.
- Peterlin, Anton; Pirkmajer, Edo. 1960. Temperature Dependence of NMR Absorbtion Spectra of Polyethylene. *Journal of Polymer Science*. 46: 185-193.
- Peterlin, Anton; Krašovec, Franc; Pirkmajer, Edo; Levstek, Igor. 1960. Dilatometric and Nuclear Magnetic Resonance Studies of Polyethylene with Different Branching and Crystallinity. *Die makromolekulare Chemie (Heidelberg)*. 37/3: 231-242.
- Peterlin, Anton. 1963. NMR and Dilatometric Studies of Polyethylene Recrystallization. *J. Appl. Phys.* 34: 102-106. Reprint: 1965. *Collected Papers*. 32-36.
- Peterlin, Anton. 1963. Bestimmung der Form und Grösse von Makromolekülen aus rheologischen Messungen. *Chemie*. 17: 65-76. Reprint: 1965. *Collected Papers*. 68-79.
- Peterlin, Anton (director & editor). 1965. *Collected Papers: A Collection of Papers Published by the Research Staff of Camille Dreyfus Laboratory [representing work on fundamental polymer research carried out during the first two years of the Laboratory's existence]*. Durham, North Carolina: Camille Dreyfus Laboratory. 105 pages (IJS Library-679, SAZU Library-II 43008 DA).
- Peterlin, Anton. Mid-September 1978. Solution Properties of Polymers. *Macromolecular science retrospect and prospect; [proceedings commemorating the silver anniversary of the Division of Polymer Chemistry, Inc. of the American Chemical Society (ACS), 1976]*, the History of the ACS Division of Polymer Chemistry, Inc. (Ed. Ulrich, Robert David for the American Chemical Society, Division of Polymer Chemistry); Macromolecular Science Series. Boston, MA: Springer US / New York: Plenum Press. volume 1, pp. 209-231 (Peterlin's biography with a report on his scientific work, concluded by his bibliography on

pp. 221-231 together with essays about F.A. Bovey, F.R. Eirich, J.D. Ferry, P.J. Flory, M.L. Huggins, L. Mandelkern, H.F. Mark, C.S. Marvel, B. Maxwell, H. Morawetz, M. Morton, C.G. Overberger, C.E. Schildknecht, J.K. Stille, M. Szwarc).

Peterlin-Neumaier, Tanja M. January-February-March 2003. Ob deseti obletnici smrti fizika prof. dr. Antona Peterlina. *Nova revija*. 22/249-250-251: 67-74.

Peterlin-Neumaier, Tanja M. 2004. Prtiček kot spomin na poznanstva v Kamniku in Ljubljana okrog leta 1893 (Kamnik about the year 1893). *Kronika*. 52: 45-54.

Petković, Tomislav. 1998. Kvantna mehanika na Heisenbergovom tragu. In: Heisenberg, Werner. *Promjene u osnovama prirodne znanosti šest predavanja. Slika svjeta suvremene fizike*. Zagreb: Kruzak.

Petraeus, Benedikt Nikolaus (ed.) 1717. *Fr. Basilii Valentini Chymische Schriften*. Hamburg: Samuel Heyl & Georg König. Reprint: 1740. Hamburg: Gottfried Richter.

Petricca Angelus de Sonneno. 1672. *De triplici philosophia Aristotelis rationali, naturali, et divina, quæ logicam, octo libros phisicorum, quatuor de cælo & mundo, duos de generatione & corruptione, seu de ortu & interitu, quatuor meteororum, tres de anima, & quatuordecim metaphisices complectitur, ad mentem doctoris subtilis. Disputationes pro juvenum studiosorum brevi, aperta, ac idonea instructione dispositæ. Auctore F. Angelo de Sonneno, ord. Min. con, S. Francisci sac. theologiæ doctore, & Sacræ Congregationis indicis consultore; olim vicario patriarchali Constantinopolitano, Sac. Congregationis pro emendatione euchologii Græcorum theologo, & sui ordinis procuratore generali*. Rome: Angelo Bernabò (FSLJ-10 h 63).

Petrov, Vasilyi Vladimirovich (Василий Владимирович Петров). 1803. *Извѣстiе о гальвани-вольтовскихъ опытахъ, которые производилъ Профессоръ В. Петровъ посредствомъ огромной наупаче баттереи, состоявшей иногда изъ 4200 медныхъ и цинковыхъ кружковъ, и находящейся при Санкт-*

Петербуржской Медико-Хирургической Академии (The news of the galvanic-voltaic experiments conducted by Professor V. Petrov with the help of an enormous amount of battery, consisting of 4200 copper and zinc circles, located at the St. Petersburg Medical and Surgical Academy). въ Санктпетербургѣ: В Государственной Медицинской коллегии (Saint Petersburg: State Medical College).

Peutz, Elisabeth. 9 October 2016. Ferlach freut sich über Nobelpreis. Eine Kärntner Familie ist begeistert über die höchste Auszeichnung für F. Duncan M. Haldane. *Kleine Zeitung Kärnten* (Graz and Klagenfurt).

Pfaff, Christoph Heinrich; Hellwag, Christoph Friedrich. 1800. *Extrait d'un mémoire sur la vaccine, considérée comme préservatif de la petite vérole, depuis long-temps constaté en Holstein par le hasard et l'usage, et sur l'inoculation de la vaccine pratiquée à Eutin, Lubeck et en d'autres endroits, dans l'été de 1800. Par le Dr Hellwag*. Paris: de l'imprimerie de Stoupe.

Pfeifer, Jože. 1990. Zdravstveno in socialno varstvo idrijskih rudarjev, *Idrijski rudnik skozi stoletja* (ed. Zupančič Pušavec, Nina; Žontar, Jože), Idrija: Mestni Muzej & Ljubljana: Zgodovinski arhiv.

Pfeifer, Jože. 1989. *Zgodovina idrijskega zdravstva*, Idrija: Mestni muzej.

Pfister, Louis. 1732, 1934. *Notices biographiques et bibliographiques sur les Jésuites de l'ancienne mission de Chine*. I-IX. Chang-hai (Shanghai): Imprimerie de la Mission Catholique.

Pfaundler, Leopold von (Platter, Hugo). 1869. Über eine neue Methode zur Bestimmung der Wärmekapazität von Flüssigkeiten. *Wien.Ber.* II 59: 145-154.

Pfaundler, Leopold von. 1869. Über Molekularwärme der Schwefelsäurehydrate und deren Verbindungswärme beim Mischen mit Wasser. *Festschrift zur 43. Naturforscherversammlung in Innsbruck 1869*. Reprint: 1870. *Ber. der deutsch.chem.Ges. (Berichte*

der deutschen chemischen Gesellschaft, 3/2 (July-December 1870): 798-800.

Pfaundler, Leopold von; Platter, Hugo. 1870. Über die Wärmecapazität des Wassers in der Nähe seines Dichtigkeitsmaximums. *Wien.Ber.* 62/7 (18th Session on 7 July 1870): 379-392. Reprint: 1870. *Ann.Phys.* 217/12: 537-551.

Pfaundler, Leopold von. 1871. *Elementare Ableitung der Grundgleichung der dynamischen Gastheorie*, *Wien.Ber.* II. 63: 159–169. Reprint: 1871. *Ann.Phys.* 220/11: 428-438.

Pfaundler, Leopold von. 1877. Über (Ueber) die Anwendung des Dopplerischen Principis auf die fortschreitende Bewegung leuchtender Gasmoleküle. *Wien. Anz.* 14: 238. Extended print: 1878. *Wien.Ber.* II. 76: 852-858.

Pfaundler, Leopold von. 1897-1898. *Müller-Pouillet's Lehrbuch der Physik und Meteorologie*. Braunschweig: Friedrich Vieweg.

Pillebois, Anton (ed.). *Wiener Universitäts schematismus für das Jahr 1798*. Wien: Thad. Edl. von Schmidbauer & Anton Pillebois.

Pichler, Franz; Augustinus Asenbaum. 2004. Zum Studium von Nikolaus Tesla in Graz und Prag, Geschichtliches. *PLUS LUCIS* 2/96: 9-14. Translation: Pichler, Franz. 2004. On the University Studies of Nikola Tesla in Graz and Prague. *EMCSR 2004, Vienna, April 13-16, 2004, Symposium Seventeenth European Meeting on Cybernetics and Systems Research University of Vienna, panel: "History of Cybernetics, Information Technology and Systems Research"*, 1-5.

Pickel, Georg. 1778. *Experimenta physico-medica de electricitate & calore animali*. Würzburg: Franc Ernest Nitribitt.

Pierre, Victor. 1866. Über die durch Fluorescenz hervorgerufene Wärmestrahlung, *Wien.Ber.* 53: 339-346. Simultaneous print: 1866. Ueber die durch Fluorescenz hervorgerufene Wärmestrahlung, *Annalen der Physik*, 204/8: 621-628.

Pierre, Victor. May 1866. Beiträge zur genaueren Kenntniß der Gesetze der Fluorescenz-Erscheinungen, *Wien.Ber.* 53: 707-709. Simultaneous print: 1866. *Beiträge zur genaueren Kenntniß der Gesetze der Fluorescenz-Erscheinungen: vorgelegt in der Sitzung vom 11. Mai 1866*. Wien: K.K. Hof- und Staatsdruckerei.

Pighetti, Clelia. 2005. *Il vuoto e la quiete. Scienza e mistica nel '600. Elena Cornaro e Carlo Rinaldini*. Milano: Franco Angeli.

Pillwein, Benedict. 1824. *Beschreibung der Provinzial-Hauptstadt Linz und ihrer nächsten Umgebung, mit der ältesten Geschichte und mit einem Umrisse des Erzherzogthums Oesterreich ob der Enns als Einleitung; von Benedikt Pillwein, k. k. Provinzial-Staats-Buchhaltungs-Ingrossisten zu Linz; Mit der Karte des Kommissariats*. Linz: Josef Fink.

Pintar, Ivan. 1925. Haymann (Haiman, Haymon) Ivan Jožef Anton (keyword). *SBL.* 1: 299.

Pintar, Ivan. 1949. Najstarejša od slovenskega avtorja priobčena anatomska podoba. *Zdravstveni vestnik.* 53-56.

Piovan, Francesco; Sitran Rea, Luciana (editors). 2001. *Studenti, universita, citta nella storia padovana, atti del convegno Padua 6-8 February 1998*, Trieste: Lint.

Pipunurov, Vasilij Nikolaevič (Пипунуров, Василий Николаевич). 1982. *Istoria časov (История Часов с древнейших времен до наших дней, History of Clocks)*. Moskva (Москва): Nauka.

Pirani, Marcello. 1906. Selbstzeigendes Vacuum-Messinstrument (Directly Indicating Vacuum Gauge). *Verh. d. D. Phys. Ges.* 8: 686-694.

Pisko, Franz Joseph. 1854. *Lehrbuch der Physik für Unter-Realschulen*. Brünn. Reprints: 2: 1855; 3: 1858; 4: 1859 (Mit Slowenischer Terminologie (with Slovenian terms, including the translations of titles of chapters)). Brünn: Carl Winiker.

Pisko, Franz Joseph. 1860. Die Fluorescenz des Lichtes, *Jahresbericht über die Oberrealschule*

Weiden (*Programm, Annual Journal of Viennese real school in Weiden*, 1860), p. 40f. Extended reprint in a book: 1861. *Die Fluorescenz des Lichtes*. Wien: Carl Gerold's Sohn. 115 pages. Related research publication: 1864. Beitrag zur Fluorescenz des Lichtes. *Annalen der Physik*, 199/9: 167-170.

Pisko, Franz Joseph. 1859. *Lehrbuch der Physik für Ober-Realschulen*. Brünn: Carl Winiker.

Pisko, Franz Joseph. 1859. *Lehrbuch der Physik für Obergymnasien*. Brünn: Carl Winiker. Reprint: 1873. *Lehrbuch der Physik für Obergymnasien*, Brünn (Brno).

Pisko, Franz Joseph. 1875. Was ist Wärme? *Programm der k.k. Real-Schule in Sechshaus bei Wien 1874/75 (Yearly Journal of Viennese Higher real school in Sechshaus by Vienna)*. Sechshaus: Selbstverlag der k.k. Realschule. Pp. 1-22. Bind to: 1875. Dritter Jahresbericht. Veröff. am Schlusse des Schuljahres 1874/75. Separate print: 1875. Wien: Seidel, 22 pages.

Pištaló, Vladimir. 2009. *Tesla, portret među maskama*. Novi Sad: Budućnost. Translation: 2012. *Tesla, portret med maskami*. Ljubljana: Modrijan.

Pizzarello, Antonio. 1889. *Esperimenti di Fisica Chimica (Un'aggiunta all'opuscolo "Di alcune esperienze ecc.")*. Macerata: Mancini.

Pizzarello, Antonio. October 1898. Piezometro per comprimere e striate i liquidi, Letta al Congresso di fisica a Torino dal 22 al 22 Settembre 1898. *Il Nuovo Cimento*, 8 (4): LI, 266-270.

Pizzarello, Antonio. 1931. *Gravitazione universale potenziale d'una ingente massa M nei punti esterni ad essa e nei punti interni*, Fabriano by Ancona: Gentile.

Plank, Josef. 1875 (published in 1876). Versuche über das Wärmeleitungsvermögen von Gasgemengen. *Wien. Ber. II Abteilung*, Presented by the secretary J. Stefan at meeting (Sitzung) of Academy on 15 July 1875, *Wien. Ber.* 72/1: pp. 269-282. Note: 1875. *Wien. Anz.* p. 172 (presented at 9th Meeting on 15 July 1875).

Plank, Josef. 1876. Über Gas-Konstante (Maxwell). *Wien. Ber. II Abteilung* 74: 215-236.

Plank, Josef. 1876. Versuche über das Wärmeleitungsvermögen von Stickstoff, Stickoxyd, Ammoniak und Leuchtgas. *Wien. Ber. II Abteilung*, 74: 215-236. Presented by the secretary J. Stefan at meeting (Sitzung) on 20 July 1876. Separate Print: 1877.

Plentaj, Fran. 1867. Vom Wurzelziehen im Allgemeinen und Wurzelziehen im Besonderen. *Sitzungsberichte der Kaiserlichen Akademie der Wissenschaften*. Wien. 169, 107; Simultaneous prints: 1867. *Anzeiger der Kaiserlichen Akademie der Wissenschaften*, 18: 154; 1867. *Denkschriften der Kaiserliche Akademie der Wissenschaften, math. Klasse.* 4/7: 54f.

Pliny the elder. 2009. *Naravoslovje. Izbrana poglavja*. Izbral, prevedel in spremno besedo napisal Hriberšek, Matej (edited, introduced and translated Hriberšek, Matej). Ljubljana: Modrijan.

Plücker, Julius. 1851. Ueber das magnetische Verhalten der Gase. *Ann. Phys.* 83/5 (volume 159 of all, no. 5): 87-108; 84/10 (volume 160 of all, no. 10): 161-180.

Plücker, Julius. 27 December 1857. Ueber die Einwirkung des Magnetes auf die Elektrischen Enladungen in verdünnten Gasen. *Ann. Phys.* 103: 88-106.

Plücker, Julius. 30 March 1858. Fortgesetzte Beobachtungen über die Elektrische Entladung durch gasverdünnte Räume. *Ann. Phys.* 103: 113-128.

Plücker, Julius. 26 August 1858. Fortgesetzte Beobachtungen über die elektrische Entladung. *Ann. Phys.* 105: 67-84.

Plücker, Julius. 1895-1896. *Julius Plückers gesammelte wissenschaftliche Abhandlungen* (eds. Schönflies, Arthur; Pockel, Friedrich Carl Alwin), vol. 2, Leipzig: B.G. Teubner.

Poda, Nikolaus von Neuhaus. 1771. *Berechnung der Luftmaschine, welche in der Niederhungerischen Bergstadt zu Schemnitz bey dem Amalie Schacht*,

vom Hrn. Joseph Carl Höll, Oberkunstmeister, erfunden, erbauet, und im Jahre 1753 den 23 März ist angelassen worden, nebst einer Kupferplatte. Wien: Joseph Kurzböck. Review by Ignaz Born: October 22, 1771. *Prager gelehrte Nachrichten*. Das (4.) Stück (volume 4): 57-59.

Poda, Nikolaus von Neuhaus. 1771. *Kurzgefachte Beschreibung der bey dem Bergbau zu Schemnitz in Nieder-Hungarn errichteten Maschinen, nebst XXII. Tafeln zu derselben Berechnung; zum Gebrauch der, bey der Schemnitzen Bergschuhe, errichteten mechanische Vorlesungen verfassten von Nicolaus Poda der Gesellschaft Jesu Priestelt, öffentl. König. Lehrer der mathematische Wissenschaften bey der Bergakademie zur Schemnitz. Herausgaben von Ignaz Edler von Born*. Prag: in der Waltherlichen Buchhandlung (NUK-11269).

Podgornik, Rudolf; Vilfan, Andrej. 2012. *Elektromagnetno polje*. Ljubljana: DMFA.

Podgoršek, Nataša. 2006. Zgodovina uprave v Mariboru 1750–1918. Občinske volitve v mestu Maribor 1861–1912. *Studia historica Slovenica*. 6/2–3: 361–379.

Podlogar, Leopold. 1921. Iz zgodovine kranjskih trgov, 4. Kostel. *Vrtec*. 51: 91-94, 102-103, 131-133.

Podolny, Roman Grigorevich; Nicholas Weinstein (translator). 1986. *Something Called Nothing: physical vacuum: what is it?* Moskva: Mir.

Poggendorff, Johann Christian. 1865. Ueber eine neue Einrichtung der Quecksilber-Luftpumpe. *Ann. Phys.* 201/125 (5): 151-160.

Poggendorff, Johann Christian. 24 April 1865. (Über einen von) Hrn. Holtz, hier in Berlin erfundenen und construirten Apparat vor, den man Influenzmaschine nennen könnte. *Monatsberichte der Akademie (Monatsberichte der Königlichen Preussische Akademie des Wissenschaften zu Berlin)*. Sitzung der physikalische-mathematische Klasse, Berlin: Akademie (published in 1866). pp. 173-174, 695.

Poggendorff, Johann Christian. 1870. Ueber das Holtz'sche Rotationsphänomen. *Ann. Phys.* (5/9) volume 215, Issue 4 139: 513-546.

Poggendorff, Johann Christian. 1875. Das Radiometer des Hrn. W. Crookes. *Ann. Phys.* 232/154 no. 11: 488-491.

Poggendorff, Johann Christian. 1863-1898. *Biographisch-Literarisches Hadwörterbuch zur Geschichte der exacten Wissenschaften von J.C. Poggendorff, I-II*, Leipzig: Johann Ambrosius Barth. Reprint: 1965. Amsterdam: B. M. Israël/ Leipzig: Barth/ Berlin: Akademie-Verlag.

Pokorn, Frančišek. 1908. *Šematizem duhovnikov in duhovnij v ljubljanski nadškofiji 1.1788*. Ljubljana: Knezo-Škofijski (Prince-Bishopric) ordinariat ljubljanski.

Polák, Joseph. 1867. A hö nagy a természet gazdástatóban (Die Grosse Rolle der Wärme in Haushalte der Natur, The great role of heat in the economy of nature). *Jahresbericht. Catholic Gymnasium of the Piarists in the city of Kecskemét, southeast of Budapest (Tudósítvány a Kegyes Tanítórent Kecskeméti Főgimnáziumáról az 1866/7-ki tanévre = Report on teaching at Kecskemét High School for the academic year 1866/7)*. Kecskemét: Printed by Károly Szilády, 3-13.

Polák, Joseph. 1868. A szelek a nagy világban, a befolyásuk az időre (The winds in the great world, their influence on weather). *Jahresbericht. Catholic Gymnasium of the Piarists in the city of Kecskemét, southeast of Budapest (Tudósítvány a Kegyes Tanítórent Kecskeméti Főgimnáziumáról az 1867/8-ki tanévre = Report on teaching at Kecskemét High School for the academic year 1867/68)*. Kecskemét: Printed by Károly Szilády, 3-10.

Polenec, Natalija. 2003. Ob desetletnici smrti akademika prof. dr. Antona Peterlina. *Novice IJS, Interno glasilo Inštituta Jožef Stefan (News of IJS)*, March 2003, no. 102, p. 6.

Poli, Giuseppe Saverio, 1752(?). *La formazione de Tuono, della Folgore, e di varie altre Meteore, spiefgata giusta le idee del Signor Franklin, da Giuseppe Saverio Poli ... : diretta al Signor D. Daniello Avelloni*. Venezia; Reprint: 1772. Napoli: Donato Campo (Zois's library now NUK-8506 on 144 pages).

Poli, Giuseppe Saverio; Giovanni Maria della Torre. 1774. *Continuazione delle Riflessioni intorno agli effetti di alcuni fulmini, ove si esaminano la Dissertazione del P. Giangaetano del Muscio, relativa alle Reflessioni medesime, lettera al P.D. Gio. Maria della Torre, di Giuseppe Saverio Poli.* Napoli (Zois' book?).

Poli, Giuseppe Saverio. 1789. *Elementi di fisica sperimentale composti per uso della regia università da Giuseppe Saverio Poli ...* Tomo 1-2. Napoli: Simoniana. Reprints: 1804. Santini, Venezia (NUK-22080); 1811. Santini, Venezia (POMPI).

Poljščuk, Efim Mikhaïlovich (Ефим Михайлович Полищук, Polishchuk). 1980. *Emil Borel.* Leningrad: Nauka.

Poljšak, Tone. 1931. Edison. *Elektrotehniški vestnik* (ed. Poljšak, Tone). 1/2: 17-18, 1/3: 33-36.

Polvani, Giovanni. 1942. *Alessandro Volta.* Pisa: Domus Galileana.

Popelka, Fritz. 1941. *Die Bürgerschaft der Stadt Graz von 1720 bis 1819, ihre blutmässige und berufliche Gliederung nach den Bürgerbüchern...* Baden bei Wien: Veröffentlichungen des Wiener Hofkammerarchivs/ published by Josef Kallbrunner.

Popović, Vojin et al (ed.). 1956. *Nikola Tesla: lectures, patents, articles* (The anthology published on 100th anniversary of Tesla's birth in Beograd in 1956, Documents taken from the Nikola Tesla Museum, Beograd. Selected and prepared with plates, including portraits by the ed. Vojin Popović, Radoslav Horvat, Nikola Nikolić). Beograd: Nikola Tesla Museum/ Državni odbor za proslavu stogodišnjice rođenja Nikole Tesle.

Poppe, Johann Heinrich Moritz von. 1804. *Encyclopädie des gesammten Maschinenwesens, oder vollständiger Unterricht in der praktischen Mechanik und Maschinenlehre: mit Erklärungen der dazu gehörigen Kunstwörter in alphabetischer Ordnung: ein Handbuch für Kameralisten, Baumeister, Mechaniker, Fabrikanten und Jeden, dem Kenntnisse der Maschinen nöthig und nützlich sind.* Volume 2. Leipzig: Georg Voß.

Porta, Giovanni Battista. 1561. *Magiae naturalis, sive: De miraculis rerum naturalium Libri III* Joanne Baptista Porta Neapolitano Auctore. Lugduni: Apud Guilielm. Roullium (Leyden: Roullius) (NUK-8284; NUK-24483).

Pöschl, Jakob. 1863. Über einen Ruhmkorffschen Induktionsapparat. *Mittheilungen des naturwissenschaftlichen Vereines für Steiermark.* 28 February 1863, 1: 51–52.

Pöschl, Jakob. 1868. Über den neuesten Typendruck-Telegrafen von Hughes. *Mittheilungen des naturwissenschaftlichen Vereines für Steiermark.* 27 April 1867, 5: XXXI.

Pöschl, Jakob. 1869. Über das transatlantische Kabel und seine Sprechmethode. *Mittheilungen des naturwissenschaftlichen Vereines für Steiermark.* 25 January 1868, 6: XXXVII–XXXVIII.

Pöschl, Jakob. 1870. Über »singende Flammen«. *Mittheilungen des naturwissenschaftlichen Vereines für Steiermark.* 7/2: LXXXXI.

Pöschl, Jakob. 1875. Über neuere Elektromaschinen insbesondere Gramme's System. *Mittheilungen des naturwissenschaftlichen Vereines für Steiermark.* Graz. 12: LXVIII–LXXI.

Pöschl, Jakob. 1879. Über das »Telephon«. *Mittheilungen des naturwissenschaftlichen Vereines für Steiermark* Jahrgang 1878. Published on 10 May 1879, 16: XXXIX–XLI.

Pouillet, Claude Servait Matthias. 1827. *Éléments de physique expérimentale et de météorologie.* Paris: Béchét. Reprint: 1853. Paris: L. Hachette. German version of Müller, Johann Heinrich Jakob: 1842. *Lehrbuch der Physik und Meteorologie*, 2 volumes, Braunschweig; Reprint: 1868-1869. *Lehrbuch der Physik und Meteorologie.* 7th edition. German version of Pfaundler, Leopold with the help of Lummer, Otto. 1886–1898. *Müller-Pouillet's Lehrbuch der Physik und Meteorologie.* 3 volumes. Pfaundler's reprint: 1897-1898. Braunschweig: Friedrich Vieweg. Pfaundler's reprint as 10th edition (10. umgearb. und verm. Auflage): 1905-1908. Braunschweig: F. Vieweg and Son (1906. [1.-2.

Buch = volumes 1-2] Mechanik und akustik, paragraph #176 *Sprengels pumpe mit selbsttätigen Quecksilberanhebung. System Schantel-Kahlbaum*, pp. XIV, 498-499 (indexed on pp. 798-799).

Pourchot, Edmund (Edme Purchotius). 1695. *Institutio philosophica ad faciliorem veterum ac recentiorum philosophorum lectionem comparata*. Paris: JP Coignard, 4 vols in 12°. Reprints: 1700. *Institutio philosophica ad faciliorem veterum et recentiorum philosophorum lectionem comparata / 2, Quo elementa geometriae & Physica generalis continentur. 3, Qui Physicam specialem comprehendit*. Parisiis: Coignard; 1711. *Institutiones philosophicae ad faciliorem veterum et recentiorum philosophorum intelligentiam comparatae*. Lugduni; (1720-) 1730. *Institutiones philosophiae... tomus 1: logica & metaphysica; tomus 2: elementa geometriae & physica generalis; tomus 3: physica specialis (particularis), tomus 4: ethica, tomus 5: Exercitationes scholasticae in varias partes philosophiae praesertimque in Aristotelis metaphysicam, sive, Series disputationum ontologicarum naturali ordine dispositarum: 1-5, Venetiis: Joanne Manfrè (FSLJ-13 f 7-10 (4 f 2-10); KSSKL-Loka S 23); 1733. Paris.*

Pourchot, Edmund (Edme Purchotius). 1700. *J.Cl. Edmundi Purchotti Exercitationes scholastico in varias partes Philosophia*. Paris: Goignard. Reprints: 1711. Lugduni: Boudet; 1738. *Exercitationes scholasticae in varias partes philosophiae, praesertimque in Aristotelis metaphysicam: sive series disputationum ontologicarum naturali ordine dispositarum: quibus praemissum est breve compendium philosophiae. Tomus quintus / opera, & studio v. cl. Edmundi Purchotii*. Patavii (Padua): Joanne Manfrè (KSSKL-Loka; City library Rijeka).

Pourprix, Bernard; Locqueneux, Robert. 1988. Josef Stefan (1835-1893) et les phénomènes de transport dans les fluides: la jonction entre l'hydrodynamique continuiste et la théorie cinétique des gaz. *Archives internationales d'histoire des sciences*. 38/120: 86-118.

Povšič, Jože. 1974. *Bibliografija Jurija Vege*. Ljubljana: SAZU.

Povšič, Jože. 1978. *Bibliografija Franca Hočevarja*.

Ljubljana: SAZU.

Povšič, Jože. 1980. *Bibliografija Franca Hočevarja in Riharda Zupančiča*. Ljubljana: Inštitut za matematiko, fiziko in mehaniko.

del Prado, Joan Martinez. 1649 *Controversiae metaphysicales sacrae theologiae ministrae, authore R.P. magistro Fr. Joanne Martinez de Prado... tomus primus : primam et secundam partem earundem complectens*. Compluti (Alcalá) 35 km northeast of Madrid: Maria Fernandez viduam (FSLJ-3 i 12).

Prager, Frank D. 1980. Berti's Devices and Torricelli Barometer from 1641 to 1643. *Annali dell' Instituto e museo di storia della scienza di Firenze*. 5/2: 35-53.

Prasad, B. S. N.; Mascarenhas, Rita. April 1978. A laboratory experiment on the application of Stefan's law to tungsten filament electric lamps. *American Journal of Physics*. 46/4: 420-423.

Pravdić, Velimir. 1995. Nuklearni program Jugoslavije 1950-ih i 1960-ih godina. Sjećanje iz žablje perspektive. *Encyclopaedia moderna: časopis za sintezu znanosti, umjetnosti i društvene prakse* (Zagreb: Hrvatska akademija znanosti i umjetnosti & Institut "Ruđer Bošković") 15/1 (45): 31-39.

Pray, Georgius (György). 1781. *Imposturae CCXVIII in dissertatione r. p. Benedicti Cetto, Clerici Regularis e Scholis Piis de Sinensium imposturis detectae et convulsae. Accedunt Epistolae anecdotae r. p. Augustini e comitibus Hallerstein ex China scriptae*. Budae: Typis Regiae Universitatis.

Pregelj, Andrej; Zalar, Anton. 2002. Dr. Jože Gasperič praznuje sedemdesetletnico. *Vakuumist*. 22/1: 27-28.

Prelovšek, Damjan. 1984. Ljubljanska arhitektura 18. stoletja, *Zgodovina Ljubljane* (ed. Gestrin, Ferdo), Ljubljana: Kronika, 177-188.

Preinfalk, Miha. 2005. *Auerspergi*, Ljubljana: ZRC SAZU.

Prica (Priča), Nikola. 1883. O odnošaju izmedju molekularne težine i gustoće plinova (parâ). *Godišnje izvješće Kralj. velike realne gimnasije u Rakovcu u Hrvatskoj za školsku godinu 1882/3 (Program realne gimn. u Rakovcu g. 1883)*. Zagreb: C. Albrecht, 1-16.

Price, Derek John De Solla. July 1980. Towards a comprehensive system of science indicators. Paper presented to the UNESCO Conference on Evaluation in Science and Technology – Theory and Practice, Dubrovnik, from June 30, 1980 till July 4, 1980, and published in the proceedings of conference. *Scientia Yugoslavica* (Zagreb: Asocijacija naučnih unija Jugoslavije (Association of Scientific Unions of Yugoslavia)). 6/1-4 (April 1980): 45–65, 137. Reprint: October 1980. Paper presented to the *Quality indicators seminar*, MIT.

Priestley, Joseph. 1755. London. Reprints: 1767. London: J. Dodsley, J. Johnson, B. Davenport, and T. Cadell; 1769. London: Dodsley, James & Johnson, Joseph & Payne, John & Cadell, Thomas; 1775. *The History and Present State of Electricity, With Original Experiments*. London: T. Lowndes & Charles Bathurst; 1966. New York: Johnson Reprint Corp. Translations: 1771. *Histoire de l'électricité / traduite de l'anglois de Joseph Priestley, avec des notes critiques; ouvrage enrichi de figures en taille-douce*. Paris: Herissant (Zois' book now NUK-GS 0 8167).

Priestley, Joseph. 1770. An Investigation of the Lateral Explosion, and of the electricity communicated to the electrical circuit, in a discharge. *Phil. Trans.* 60 (17700101): 192-210.

Priestley, Joseph. 1772. Observations on different kinds of air. *Philosophical transactions*, 62: 147-264 (read in March 1772. Simultaneous print. 1772. *Observations on different kinds of air*, London: W. Bowyer and J. Nichols. Translations: 1775-1780. *Experiences et observations sur différentes especes d'air*. Paris (Zois' book now NUK-8443); Translation of Christian Friedrich Ludwig: 1778-1787. *Versuche und Beobachtungen über verschiedene Gattungen der Luft*. 6 Thle. Aus dem Engl. Wien/Leipzig: Rudolph Gräffer (NUK-GS 8534).

Priestley, Joseph. 1777. *Dr. Joseph Priestley's Vorlesungen über Redekunst und Kritik. Aus den Englischen übersetzt von Johann Joachim Eschemburg*. Leipzig: Schwikert (NUK-GS 6190).

Priestley, Joseph. 1966. *A Scientific Autobiography of Joseph Priestley, 1733-1804*. Selected Scientific Correspondence (ed. Robert E. Schofield). Cambridge, Massachusetts/London: The M. I. T. Press.

Puff, Rudolf Gustav. 1847. *Marburg in Steiermark, seine Umgebung, Bewohner und Geschichte*. 1-2. Graz: Leykam. Translation with additions of Curk, Jože: 1999. *Maribor: njegova okolica, prebivalci in zgodovina*. Maribor: Obzorja.

Pugač, Boris Jakovlevič (Пугач, Борис Яковлевич). 2004. *Fundamentalnije problemi istorii i filosofii nauki - ucebnoe posobie dlja studentov vyssih ucebnyh zavedeni* (Фундаментальные проблемы истории и философии науки - учебное пособие для студентов высших учебных заведений, *Fundamental problems of the history and philosophy of science - textbook for students of higher educational institutions*). Harkov: Fakt.

Puluj, Johann (Ivan Pavlovich Pului, Іван Пáвлович Пулúй). 1874, 1875. Über die Reibungsconstante der Luft als Function der Temperatur. *Wien.Ber. II*. 69 (February 1874): 287-317; 70 (July 1874): 243-267.

Puluj, Johann (Ivan Pavlovich Pului, Іван Пáвлович Пулúй). 1875. Ueber einem Schulapparat zur Bestimmung des mechanischen Wärmeäquivalents, *Wien.Ber. II* 71: 677-686. Reprint: 1876. Ueber einen Schulapparat zur Bestimmung des mechanischen Wärmeäquivalentes. *Annalen der Physik*. 233(3): 437–446. Translation: 1875. On a school lecture-room apparatus for the determination of the mechanical equivalent of heat. *The London, Edinburgh, and Dublin Philosophical Magazine and Journal of Science*, 49/326 (187505): 416-425. Separate publication: 1875. London: Taylor and Francis.

Puluj, Johann (Ivan Pavlovich Pului, Іван Пáвлович Пулúй). 1876. Ueber die Abhängigkeit der Reibung

der Gase von der Temperatur *Wien.Ber.* II 73: 589-628 [67-78].

Puluj, Johann (Ivan Pavlovich Pului, Ів́ан Па́влович Пулю́й). 1877. Ueber die Abhängigkeit der Reibung der Gase von der Temperatur. *Ann. Phys.* 237/6: 296-310.

Puluj, Johann (Ivan Pavlovich Pului, Ів́ан Па́влович Пулю́й). 1878. Über die Reibung der Dämpfe. *Wien.Ber.* Abteilung II volume 78 (July 1878), 33 pages, one table. Abridged Translation: 1878. On the friction of vapours. *The London, Edinburgh, and Dublin Philosophical Magazine and Journal of Science*, 6/35 (187808): 157-159.

Puluj, Johann (Ivan Pavlovich Pului, Ів́ан Па́влович Пулю́й). 1880. Strahlende Elektrodenmaterie, *Wien.Ber.* 81: 864-923.

Puluj, Johann (Ivan Pavlovich Pului, Ів́ан Па́влович Пулю́й). 1880. The Fourth State of Matter. A Refutation, *Science*, 1/5: 58-59.

Puluj, Johann (Ivan Pavlovich Pului, Iwan Pawlowytsch, Ів́ан Па́влович Пулю́й). 1883. *Strahlende Elektrodenmaterie und der sogenannte vierte Aggregatzustand.* Wien: Carl Gerold Sohn. Translation: 1889. Radiant Electrode Matter and the so-called Fourth State (Elektrode Matter). *Physical Memoirs Selected and Translated from Foreign Sources, Under the Direction of the Physical Society of London*, London: Taylor & Francis, 1888/1889, 1/2: pp. 233–331.

Puluj, Johann (Ivan Pavlovich Pului, Iwan Pawlowytsch, Ів́ан Па́влович Пулю́й). 1896. *Über die Entstehung der Röntgen'schen Strahlen und ihre photographische Wirkung* About the Entrance of the X-rays and their photographic affects). *Wien. Ber.* (*Wiener Berichte II Abt.*) 105: 228–238.

Puluj, Johann (Ivan Pavlovich Pului, Iwan Pawlowytsch, Ів́ан Па́влович Пулю́й). 1896. Nachtrag zur Abhandlung „Über die Entstehung der Röntgen'schen Strahlen und ihre photographische Wirkung“ (Continuation). *Wiener Berichte*, 105: 243–245.

Puluj, Johann (Ivan Pavlovich Pului, Iwan Pawlowytsch, Ів́ан Па́влович Пулю́й). February 2, 1898. Mittheilungen. Auszüge aus Technischen Teitschriften: Ueber elektrische Wellen und die Telegraphie ohne Draht. Aus dem Vortrage des Herrn Professors Dr. J. Puluj in der Wochenversammlung (Vortrag gehalten in der Wochenversammlung des Architekten- und Ingenieur-Vereines in Böhmen) am 4 Februar 1898. Im Hörsaale der Physik an der k. k. deutschen technischen Hochschule hielt Herr Professor Dr. Joh. Puluj einen durch vorzügliche Experimente erläuterten Vortrag tiber „Elektrische Wellen und die Telegraphie ohne Draht“ (On electric waves and wireless telegraphy). Wochenversammlung. *Technische Blätter (Zeitschrift des Deutschen Polytechnischen Vereins in Böhmen (Deutscher Polytechnischer Verein in Böhmen))*: *Vierteljahrschrift des Deutschen Ingenieur- und Architekten-Vereines in Böhmen (Zprávy spolku architektů a inženýrů)* 30 (1898): 37-38. Prague: Verlag des Deutschen polytechnischen Vereines in Böhmen.

Punch, John (Joannes Poncius Hyberno Corcagiensi). 1642-1643. *Integer philosophiae cursus ad mentem Scoti: in tres partes diuisus. Pars 1 & 2* (1642), *Tertia pars* (1643), *Complectens libros de gen. & corrup., meteoris, anima, paruis naturalibus, & metaphysica.* Romae: Hermann Scheus & Typis Ludouici Grignani (FSLJ-4 g 52-54, propriety entry of Johan Bapt de Presheren from Heldenfeld (* abt. 1600 Hraše)). Modified Reprint: 1672. *Joannis Poncii Philosophiae ad mentem Scoti cursus integer: primum quidem editus in Collegio Romano Fratrum Minorum Hibernorum; nunc vero demum ab ipso authore In Conventu Magno Parisiensi recognitus ... insuperque morali philosophiâ ... locupletatus.* Lugduni (Leuven): Anisson (FSLJ-8 a 41).

Puschl, Karl. 1851. *Mechanische Theorie der Naturkräfte*, Wien: Gerold.

Puschl, Karl. 1861, 1862. Über den Ursprung und die Gesetze der Molecularkräfte nach dem Principe der Krafterhaltung. *Jahres-Bericht des Kaiserl.-Königl. Obergymnasiums zu Melk*, volume 11 (1861, paragraphs 1-6 on pages 3-44) and volume 12 (1862, paragraphs 7-10 on pages 3-21). Wien: Ludwig

- Mayer. Separate print of second part on 21 pages: 1862. Wien: Ludwig Mayer (Also noted as: *Über das Ursprung und die Gesetze der Naturkräfte nach mechanische Theorie der Wärme*).
- Puschl, Karl. 1862. Über den Wärmezustand der Gase. *Wien. Ber. II.* 45: 357-384.
- Puschl, Karl. 1863. Notiz über die Molekularbewegung in Gasen. *Wien. Ber. II.* 48: 35-39 (meeting on 11 June 1863).
- Puschl, Karl. 1869. *Das Strahlungsvermögen der Atome, als Grund der physikalischen und chemischen Eigenschaften der Körper*. Wien: Gerold.
- Puschl, Karl. 1870. *Ueber Wärmemenge und Temperatur der Körper*. *Wien. Ber. II.* 62: 171-196. Separate print: 1870. *Über die Wärmemenge und Temperatur der Körper*. Wien. 26 pages.
- Puschl, Karl. 1870. Über eine kosmische Anziehung, welche die Sonne durch ihre Strahlen ausübt. *Wien. Ber. II.* (7th Meeting on 10 March 1870) Volume 61: 299–318 (20 pages).
- Puschl, Karl. 1874. Über die Mitbewegung des Lichtes in bewegten Mitteln. *Wien. Ber. II.* 68: 446-456 (Meeting on 20 November 1863, 11 pages). Simultaneous print: 1874. *Carl's Rep.* 10: 171-179.
- Puschl, Karl. 1874. Bemerkung zur specifischen Wärme des Kohlenstoffs. *Wien. Ber. II.* 69: 142-147. Simultaneous prints: 1874. *Carl's Rep.* 10: 166-170; 1874. *Wien. Anz.* 11: 21-23.
- Puschl, Karl. 1874. Über Körperwärme und Ätherdichte. *Wien. Ber. II.* 69: 324-333. Simultaneous prints: 1874. *Carl's Rep.* 10: 425-433; 1874. *Wien. Anz.* 11: 45-46.
- Puschl, Karl. 1875. Über eine Modification der herrschenden Gastheorie. *Wien. Ber. II.* 70: 413-432. Simultaneous print: 1875. *Carl's Rep.* 11: 42-58.
- Puschl, Karl. 1875. Über das Verhalten gesättigter Dämpfe. *Wien. Ber. II.* 70: 571-588.
- Puschl, Karl. 1875. Ueber die Volumenveränderung des Kautschuks durch Wärme. *Wien. Ber. II.* 71: 95-98. Simultaneous print: 1875. *Carl's Rep.* 11: 102-105.
- Puschl, Karl. 1875. Über den Einfluss von Druck und Zug auf die thermischen Ausdehnungscoefficient der Körper und über das bezügliche Verhalten von Wasser und Kautschuk, *Wien. Ber. II.* 72: 245-256 (Meeting on 24 June 1875).
- Puschl, Karl. 1875. Erniedrigung der Temperatur des Dichtigkeitsmaximums des Wassers durch Druck. *Wien. Ber. II.* 72: 283-286. Note: 1875. *Wien. Anz.* p. 172 (9th Meeting on 15 July 1875).
- Puschl, Karl. 1878. Grundzüge der Aktinischen Wärmetheorie, *Wien. Ber. II.* 77: 471-500.
- Puschl, Karl. 1879. *Über die latente Wärme der Dämpfe*, Wien. Note: *Wien. Ber.* 82: 369 (presented by the secretary J. Stefan at the meeting of 11 November 1880). Extended Reprints: 1879. *Über die latente Wärme der Dämpfe eine Theor. Betrachtung der Dampf- und Gasform der Körper mit bloßer Voraussetzung der Äquivalenz von Wärme und Arbeit*. Wien: A. Hölder (Review by Wallentin, I.G.: 1879. *Z. öst. Gym.* 33: 228-229); 1881. 2nd edition. Wien; 1883. *Über die latente Wärme der Dämpfe eine Theorie der Dampf- und Gas-Form der Körper auf Grund der Äquivalenz von Wärme und Arbeit; mit Schlussfolgerungen über den physischen Zusatz der Sonne und der Kometen*. 3rd edition (3. Auflage), Wien: Hölder, 4+76 pages.
- Puschl, Karl. 1906. Über die Quelle der vom Radium entwickelten Wärme. *Anzeiger der Kaiserlichen Akademie der Wissenschaften.* 16: 270-273.
- Pusterla, Gedeone. 1891. *I rettori di Egida Giustinopoli Capo d'Istria. Cronologie, elenchi, genealogia, note, appendice*. Capodistria (Koper): Andrea Tommasich.
- Pyenson, Lewis; Jean-François Gauvin (editors to David M. Stewart Museum). 2002. *The Art of Teaching Physics: The Eighteenth-century Demonstration Apparatus of Jean Antoine Nollet*

(*L'art d'enseigner la physique*). Sillery, Québec: Les éditions du Septentrion.

Quincke, Georg Hermann. 1863. Ueber die optischen Eigenschaften der Metalle. *Ann. Phys.* 119: 369-384.

Rabesano, Livio da Montursio (Rabesanus of Vicenza). 1664-1674. *Cursus Philosophicus ad mentem Doctoris subtilis Ioannis Duns Scoti Ordinis Minorum: pro Tyronibus Scotistis planiori stylo exaratus, ac in tres partes aptè diuisus: cum duplici indice locupletissimo, 1-3*. Part 1 published in 1664: *Physica*; Part 2 published in 1664: *Pars secunda octo libros Aristotelis de physico auditu luculenter continens*. In 1665: *Logicam minorem et maiorem; Mundo et coelo; Prima secundae partis complectens quatuor libros de coelo, et mundo (1672); Secunda secundae partis: meteorologicorum quatuor libros Aristotelis complectens, ac expendens in 1668; Pars tertia. Tres libros Aristotelis de Anima diligenter expendens in 1665*. Venetiis: Nicolo Pezzana (KKKRS; FSLJ-10 b 35-37, propriety entry: *ad usum fris Pauli Budciniz* (Budnić, Paul Budinich, Budinović) *ad mim elect episc Petin 1667*. Dedicated to the Abbot Maria Rhinr de Politeo OFM general; other copy FSLJ-10 b 35-37 with propriety entry: *ad usum Antonis Kraa 1672/ dfris Petri Francisci/* glued on the other side of the title page: *exlibris Petri Francetich a Fluminensis bibliothecae contus Tersatum OFM reformatum* (from Trsat above Rijeka)).

Rack, Philip D.; Naman, Ananth; Holloway, Paul H.; Sun, Sey-Shing; Tuenge, Richard T. 1996. Materials Used in Electroluminescent Displays, *MRS Bulletin* (published by the Materials Research Society of Warrendale, Pa. in partnership with Cambridge University Press). 21/3 (March 199603): 49-58.

Radics, Peter Pavel von; Denner, L. A. (supposed author); Hönder, Martin; Harrer, Melchior (signed the dedication). 1865. *Der verirrte soldat; oder: Des Glück's Probirstein. Ein deutsches Drama des XVII Jahrhunderts aus einer Handschrift der k.k. Studienbibliothek in Laibach*, Zagreb (Agram): Franz Suppan.

Radics, Peter Pavel von. 1878. Die Hausbibliothek der Auersperge. In: *Neuer Anzeiger für*

Bibliographie und Bibliothekswissenschaft (ed. Petzholdt, Julius, Dresden: G. Schönfeld's Verlagsbuchhandlung). 10-17, 50-55.

Radics, Peter Pavel von. 1885. IV. Ernstes und Heiteres aus einer Cavalierbibliothek des 17. Jahrhunderts, In Radics, Peter Pavel von: *Bilder Oesterreichischer Vergangenheit und Gegenwart*. Leipzig: Verlag von "Auf der Höhe" Leopold von Sacher-Masoch, pp. 26–32. Separate print 1885: Ernstes und Heiteres aus einer Cavalierbibliothek des 17. Jahr-hunderts. Leipzig: Leopold von Sacher-Masoch.

Radics, Peter Pavel von. 1885. V. Vergilbte Studentenbriefe, In Radics, Peter Pavel von: *Bilder Oesterreichischer Vergangenheit und Gegenwart*. Leipzig: Verlag von "Auf der Höhe" Leopold von Sacher-Masoch, pp. 32–40.

Radics, Peter Pavel von. 1910. *Johann Weikhard Freiherr von Valvasor (geb. 1641, gest. 1693)*. Ljubljana: Krainischen Sparkasse.

Radics, Peter Pavel von. 1912. *Die Entwicklung des deutschen Bühnenwesens in Laibach*. Ljubljana.

Radić, Momčilo. 1992. *Nikola Tesla ustvarjalna pot izumitelja. Ob 135 letnici rojstva. 2 Patenti N. Tesle v risbah*. Maribor: Birostoritve.

Radić, Nikola. 2020. Dominov opis pneumatske pumpe temeljene na apsorpciji drvenog ugljena. In symposia: (ed. Snježana Paušek-Baždar). *Hrvatski fizičar i kemičar Josip Franjo Domin (1754. – 1819.), dvjesto godina poslije. Rasprave i građa za povijest znanosti*, Zagreb: HAZU, knjiga 20, svezak 8 (volume 20, part 8).

Radossi, Giovanni. 2014. *Il carteggio P. Kandler - T. Luciani (1843-1871)*. Rovigno: Centro di ricerche storiche / Fiume: Unione italiana / Trieste: Università popolare.

Ragep, Jamil F. 2007. Copernicus and His Islamic Predecessors, Some Historical Remarks. In: *History of Science (Hist.Sci.)* 45: 65–81.

Rainer, Johann. 2001. Nuntiatur des Girolamo Portia und Korrespondenz des Hans Kobenzl 1592–1595,

Bearbeitet von Johann Rainer; unter Mitarbeit von Heinz Noflatscher und Christian Rainer. *Grazer Nuntiatur*. 3. Band (volume 3, Wien: Österreichischen Akademie der Wissenschaften). Separate print: 2001. *Nuntiatur des Girolamo Portia und Korrespondenz des Hans Kobenzl 1592–1595*, Bearbeitet von Johann Rainer; unter Mitarbeit von Heinz Noflatscher und Christian Rainer. Wien: Österreichischen Akademie der Wissenschaften.

Rajhman, Jože. 1982. Trubar (Truber) Primož (keyword). *SBL*. 4: 206-225.

Rajhman, Jože. 1986. *Pisma Primoža Trubarja*. Ljubljana: SAZU.

Raju, Chandra Kant. 2007. *Cultural Foundations of Mathematics: The Nature of Mathematical Proof and the Transmission of the Calculus from India to Europe in the 16th c. AD*. Delhi: Pearson Longman.

Raju, Chandra Kant. 2009. *Is Science Western in Origin?* Penang, Malaysia: Multiversity and Citizen's International.

Rakovec-Felser Zlatka. 2013. *Na valovih sreče in pogube. Kraljica Barbara Celjska*. Maribor: Pivec.

Ramelli, Agostino. 1588. *Le diverse et artificiose machine del Capitano Agostino Ramelli (The various and ingenious machines of Captain Agostino Ramelli)*. Paris: self-publishing.

Ramovš, Fran (general secretary of Academy ASA (AZU) in 1942-1950); Vidmar, Milan (president of Academy ASA (AZU)). 1943. *Letopis Akademije znanosti in umetnosti (The Yearbook of the Slovenian Academy of Sciences and Arts)*. 1938-1942 (1943) volume 1.

Ramovš, Fran (general secretary of Academy SASA in 1942-1950, renamed from ASA (AZU) in November 1943); Kidrič, France (president of Academy SASA SAZU) in 1945-1950). 1950. *Letopis Akademije znanosti in umetnosti (The Yearbook of the Slovenian Academy of Sciences and Arts)*. 1948-1949 (1950) volume 3.

Ranschburg, Heinrich; Gilhofer, Hermann (by their heirs). 1923. *Rare and valuable books, incunabula,*

woodcutbooks, important library-works. Books on the fine arts comprising duplicates of the Imperial (National) Library, Vienna, the library of the counts Inzaghi, and other purchases recently added to our stock (Catalogue / 157). Vienna: Hermann Gilhofer & Heinrich Ranschburg, volume 2.

Ravnik, Matjaž. 1997. *Topla greda: podnebne spremembe, ki jih povzroča človek*. Ljubljana: Tangram.

Ravnik, Matjaž; Južnič, Stanislav. 2010. Milan Čopič, oče jedrskega reaktorja v dolski občini (ob 20-letnici smrti). *Iz dežele Jurija Vege: Zbornik občine Dol pri Ljubljana (Anthology, ed. Omerzu, Stane)*. Ljubljana: Občina Dol. 2: 183-195.

Ray, John. 1691. *The wisdom of God manifested in the works of the creation being the substance of some common places delivered in the chappel of Trinity-College, in Cambridge / by John Ray, M.A. sometime Fellow of Trinity-College in Cambridge, and now of the Royal Society*. London: Samuel Smith. Translated and commentated by Caspar Calvör (Calvoer): 1717. *Gloria Dei, oder Spiegel der Weissheit und Allmacht Gottes, offenbahret in denen Wercken der Erschaffung. Erstmahls in engelländischer Sprache beschrieben von ... Johanne Ray ... nunmehr ... ins Teutsche übersetzt und mit Anmerckungen illustriret durch Casparem Calvör*. Bind to: *Bericht vom Leben und Ende des ... Grafen Johns von Rochester ... durch ... Gilbert Burnet*; and with: *Demonstratio existentiae et attributorum Dei ... a Sammuele Clarkio (=Samuel Clarke)*. Goslar in Lower Saxony: publisher Johann Christoph König & printer Johann Georg Sievert.

Raynal, Guillaume-Thomas-François. 1981. *Histoire philosophique & politique des Deux Indes*. Paris: La Découverte.

Razpet, Marko. 2009. Spominska plošča Francu Hočevarju. *Obzornik za matematiko in fiziko*. 56/4: 136-143.

Razpet, Marko. 2009. Book Review: William P. Berlinghoff in Fernando Q. Gouvêa: *matematika skozi stoletja*, Modrijan, Ljubljana 2008, 224 pages. *Obzornik za matematiko in fiziko*. 56/4: 160-161.

- Redhead, Paul Aveling. 1984. The measurement of vacuum pressures. *History of Vacuum Science and Technology* (ed. Madey, Theodore Eugene; Brown, William Charles). New York: American Vacuum Society & American Institute of Physics. 31-37.
- Redhead, Paul Aveling. (ed.). 1994. *Vacuum Science and Technology, Pioneers of the 20th Century: a volume commemorating the 40th anniversary of the American Vacuum Society (History of Vacuum Science and Technology, Volume 2)*, New York: American Institute of Physics.
- Readhead, Paul Aveling. May/June 1998. The birth of electronics: Thermoionic emission and vacuum. *J. Vac. Sci. Technol. A* 16 (3): 1394-1401.
- Redhead, Paul Aveling. 1999. The ultimate vacuum. *Vacuum*. 53: 137-149.
- Redtenbacher, Ferdinand. 1852. *Prinzipien der Mechanik und des Maschinenbaues*. Mannheim: Friedrich Bassermann. Reprint: 1859. Mannheim: Friedrich Bassermann.
- Redtenbacher, Ferdinand. 1857. *Das Dynamiden-System: Grundzüge einer mechanischen Physik*. Mannheim: Friedrich Bassermann.
- Redtenbacher, Ferdinand. 1861. *Die anfänglichen und die gegenwärtigen Erwärmungszustände der Weltkörper*, Mannheim: Friedrich Bassermann.
- Reeves, Richard. 2008. *A Force of Nature: The Frontier Genius of Ernest Rutherford (Great Discoveries)*. New York: W.W. Norton & Company.
- Regnault, Noel. 1729. *Entretiens physiques d'Ariste & d'Eudoxe, ou, Physique nouvelle en dialogues: qui renferme précisément ce qui s'est découvert de plus curieux & de plus utile dans la nature: enrichis de beaucoup de figures*. Paris : brothers Osmont & C.-L. Thiboust & J. Clouzier. Italian translation: 1736. *Trattenimenti fisici d'Aristo, e d'Eudosso, o sia Fisica nuova in dialoghi, che contiene particolarmente ciò, che s'è scoperto di più curioso, e più utile nella natura / adornati con molte figure, dal padre Regnault, ed ora dalla lingua francese nell'italiana tradotti*. 1-3. Venezia: Sebastiano Coleti (POMPI). Translated by the student Georgio Zobel into Latin language: 1755. *Physicae Recentioris Origo Antiqua per Dialogos Epistolares Demonstrata*. Graecii: Widmannstad (Widmanstetter, promoted by Franc Tricarico, Josef Mayr (Mayer) and others), FSLJ-6 g 15; J-606 W-1554 now NUK-GS 8480).
- Reibenschuh, Franz Anton. 1867. Über die Alpen. *Mittheilungen des naturwissenschaftlichen Vereines für Steiermark*. 4: XXXV.
- Reibenschuh, Franz Anton. 1868. Die Grotte bei Sachsenfeld. *Mittheilungen des naturwissenschaftlichen Vereines für Steiermark*. 5: 76–84.
- Reibenschuh, Franz Anton. 1871. Die neueren chemischen Theorien: Einleitung in das Studium der modernen Chemie. *Erster Jahresbericht der k. k. (Kaiserlich-Königliche) Staats-Oberrealschule in Marburg Veröffentlicht von der Direction am Schlusse des Studienjahres 1871*. Maribor: Edvard Janšič (Marburg: Eduard Janschitz), pp. 3-53.
- Reibenschuh, Franz Anton. 1871. Über Grubengas und neuere Beleuchtungsstoffe. *Mittheilungen des naturwissenschaftlichen Vereines für Steiermark*. CXLII– CXLV.
- Reibenschuh, Franz Anton. 1877. Über die Harze mit besonderer Berücksichtigung der fossilen Harze Steiermarks. *Fünfter Jahresbericht der k. k. Staats-Oberrealschule in Graz*. 50 pages.
- Reibenschuh, Franz Anton. 1878. Über die Theorie der Flamme. *Mittheilungen des naturwissenschaftlichen Vereines für Steiermark*. 20 January 1877. XXVII–XXXVI.
- Reibenschuh, Franz Anton. 1883. Über das Methylbiguanid und seine Verbindungen. *Monatshefte für Chemie und verwandte Teile anderer Wissenschaften*. 4/1: 388–394.
- Reich, Günter. 1994. Wolfgang Gaede, In: Redhead (ed.), *Vacuum Science and Technology, Pioneers of the 20th Century, History of vacuum science and technology*, Vol. 2, New York: AIP Press.

- Reich, Leonard S. 1983. Irving Langmuir and the Pursuit of Science and Technology in the Corporate Environment, *Technology and Culture*, (April 1983) 24: 199-221.
- Reid, Constance. 1970. *Hilbert: with an appreciation of Hilbert's mathematical work by Hermann Weyl*. Berlin / Heidelberg / New-York: Springer-Verlag. Translation of Constance Reid's (Констанс Рид) book by Игор Владимирович Долгачев (Igor Dolgachev) under the redaction of Реваз Валерианович Гамкрелидзе (Revaz Valerianovic Gamkrelidze): 1977. *Гильберт с приложением обзора Германа Вейля математических трудов Гильберта (Gil'bert (Gilbert): s priloženiem obzora Germana Vejlâ matematičeskih trudov Gil'berta, Hilbert with an appendix by Hermann Weil of reviewed Hilbert's mathematical works)*. Moskva: Nauka.
- Reisch, Gregor. 1508. *Margarita philosophica noua*. Strasbourg: Joannes Grüninger (propriety entry of Gregor Bossi who gave the book to the Protestant Lenart Budina, after the Catholic confiscation catalogued by Terpin, now NUK-GS I 4898). Italian translation printed in 1599: *Margarita filosofica del R.P.F. Gregorio Reisch nella quale si trattano tutte le dottrine comprese nella ciclopedia*. Vinegia (Venice): Barezzo Barezzi e Compagni (FSLJ-16 b 20 with propriety entry of Leonard Butorčič dated in 1648 and Ljubljana Franciscan monastery in 1678).
- Reisner, Joseph. 1913. *Fizika za višje razrede srednjih šol (Physics for upper classes of secondary schools)*. Ljubljana: Založil knezoškof. zavod sv. Stanislava v Št. Vidu nad Ljubljano.
- Reisp, Branko. 1982. Valvasor, Janez Vajkard, baron (1641–1693) (keyword). *SBL*. Ljubljana: SAZU. 3/13: 220.
- Reisp, Branko. 1983. *Janez Vajkard Valvasor*. Ljubljana: Mladinska knjiga (Juvenile books).
- Reisp, Branko. 1987. *Korespondenca Janeza Vajkarda Valvasorja z Royal Society*. Ljubljana: SAZU.
- Reisp, Branko. 1989. O nekdanji knjižnici knezov Auerspergov (Turjaških) v Ljubljani. *Zgodovinski časopis* 43/1: pp. 37–47.
- Reithammer, Anton Emil. 1866. Feuerkugel am 6. September 1866 in Pettau. *Zeitschrift der österreichischen Gesellschaft für Meteorologie*, 1: p. 250.
- Reithammer, Anton Emil. 1867. Über (Ueber) den Ozongehalt der atmosphärischen Luft. *Mittheilungen des naturwissenschaftlichen Vereines für Steiermark*. 76–80 (read on 10 December 1865).
- Reitlinger, Edmund. 1861. Ueber die Schichtung des elektrisches Lichtes. *Wien. Ber.* II 43: 15-25.
- Reitlinger, Edmund. 1861. Vorläufige Note über Lichtenberg'sche Figuren in verschiedenen Gasen: vorgelegt in der Sitzung am 3. Jänner 1861. *Wien. Ber.* II 43: 25-26.
- Reitlinger, Edmund. 1861. Erläuterungen über Lichtenberg'sche Figuren. *Wien. Ber.* II 43: 531-544.
- Reitlinger, Edmund; Kraus, Franz. 1862. Über Brande's elektrochemische Untersuchungen: vorgelegt in der Sitzung vom 10. Juli 1862 (About William Thomas Brande's electrochemistry researches). *Wien. Ber.* II 46: 368-389.
- Reitlinger, Edmund, Zerjav (Žerjav), Luka. July 24, 1862. Über Schichtung durch Entladungsschläge der Leidner Batterie. *Wien. Ber.* II 46: 352-361.
- Reitlinger, Edmund; Urbanitzky, Alfred von. 1876. Über einige merkwürdige Erscheinungen in Geissler'schen Röhren, *Wien. Ber.* II 73: 685-689.
- Reitlinger, Edmund; Urbanitzky, Alfred von. 1879. Über (Ueber) die Erscheinungen in Geissler'schen Röhren unter äusserer Einwirkung. Abtheilung 1 (About the phenomena in Geissler's tubes under external influence. Part 1, Submitted at the meeting on February 19, 1880). *Wien. Ber.* II 80: 665-686.
- Reitlinger, Edmund; Wächter, Friedrich. 1880. Über elektrische Ringfiguren und deren Formveränderung durch den Magnet: vorgelegt in der Sitzung am 10. Juni 1880 (Submitted at the meeting on June 10,

1880; For the volume LXXXII of the Meeting of the Imperial Academy of Science, 2nd Section, June Issue, year 1880). *Wien. Ber.* II, 82/15: 116-119.

Reitlinger, Edmund; Urbanitzky, Alfred von. 1880. Über die Erscheinungen in Geissler'schen Röhren unter äusserer Einwirkung. Abtheilung 2. Vorgelegt in der Sitzung am 15. Juli 1880; Aus dem LXXXII. Bande der Sitzb. der K. Akad. der Wissensch. II. Abtheilung Oct.-Heft. Jahrgang 1880 (About the phenomena in Geissler's tubes under external influence. Part 2. Submitted at the meeting on July 15, 1880; For the volume LXXXII of the Meeting of the Imperial Academy of Science, 2nd Section, October Issue. year 1880). *Wien. Ber.* II 82: 665-686 (preliminary note at 82 (17/19): 166).

Remškar, Maja et al. 20 April 2001. Self-Assembly of Subnanometer-Diameter Single-Wall MoS₂ Nanotubes. *Science*. 292/5516: 479-481.

Resch, Peter. 1884, 2012. *Das Moderne Kriegsrecht der Civilisirten Staatenwelt*. Graz / Leipzig: U. Moser.

Rezanov, Igor Aleksandrovich (Резанов, Игорь Александрович). 1988. *Istorija stanovlenija nauk o zemle* (История становления науки о земле, History of establishment of Earth Sciences). *VIET*. 2: 25-35.

Richardson, William. 1790. *Designed chiefly for the use of manufacturers: The chemical principles of the metallic arts; with an account of the principal diseases incident to the different artificers; The Means Of Prevention And Cure; and a concise introduction to the study of chemistry*. By W. Richardson, Surgeon, F.S.A. Sc. Birmingham: Printed by Thomas Pearson, also sold in London: Baldwin; Translation: 1792. *Chemie der Metalle für Fabrikanten und Manufakturisten*. Aus dem Engl. Leipzig: Weygand.

Richardson, Owen Willams. 1905. Conductibilité électrique communiquée au video par les conducteurs chauds. *Les quantités* (ed. Abraham & Langevin). 381-601.

Richter, Kurt R. 2007. Nikola Tesla' European Time. *Proceedings of the Symposium »Tesla in*

Croatia« Annual Report on the Activities of the Croatian Academy of Engineering 2006. 335–357.

Riccioli, Giovanni Battista. 1651. *Almagestum Novum astronomiam veterem novamque complectens observationibus aliorum et Propriis Novisque Theorematis, Problematibus, ac Tabulis promotam : In Tres Tomos Distribvtam, quorum argumentum sequens pagina explicabit*. Bononia: Haeredis Victoris Benatis. (J-544 with Propriety entry: Labacensis Collegii Societatis JESU Catalogo inscriptus Anno 1709, now NUK-4034).

Riccioli, Giovanni Battista. 1669. *Chronologiae reformatae et ad certas conclusiones redactae tomi tres*, in one volume, Bononiae: haeredis Dominici Barberij (Jesuitical book with propriety entry: Colegij Labac[ensis] Soc[ietatis] Jesu catalogo inscriptus A[nno] 1718, now NUK-GS III 212).

Rieger, Christian. 1758. *Universae Architecturae Militaris Elementa brevibus ... Soc. Iesu Sacerd. Mariae Theresiae Augustae honoribus d[ed]icata a Joanne Baptista L. B. De Schilson, dum idem sub augustissimis auspiciis in collegio regio Theresiano S. J. tentamen publicum ex disciplinis philosophicis atque historicis subibat*, Wien: Trattner (ST; NUK-8123).

Rieger, Johann Christoph. 1742-1743. *Introductio in notitiam rerum naturalium et arte facturum, quarum in communi vita sed praecipue in medicina usus est; exponens materiam medicam seu historiam simplicium, medicamenta composita eorumque componendorum nationes, et therapeuticas remediorum classes; una cum terminis apud botanicos, chemicos et pharmacopæos*. 4 parts in 2 volumes (published the secret of embalming according to the Dutch Frederik Ruysch's system and reprinted I.L. Blumentrost's study of glandular waters in the Olonets province (Олонецкая губёрния) without having the rights to such publications). The Haag: Peter (Pierre) Gosse.

Riess, Peter Theophil. 1845. Zur Phosphorescenz des Diamants (Phosphorescence of Diamant). *Ann.Phys.* 64 (140/2): 334-335.

Rinaldi, Bianca Maria. 2006. *The "Chinese Garden in Good Taste" Jesuits and Europe's Flora and Art*

of the Garden in the 17th and 18th Centuries.
München: Martin Meidenbauer.

Rinmann, Sven (Rinman). 1772, *Anledning ar til kunskap om den gröfre jern-och stål-förädlingen och des förbättrande / upteknade af Sven Rinman (Needs for knowledge about the coarser iron and improved steel refinement)*. Stockholm: Fouyt (Zois's book now NUK-GS 0 11255).

Rinmann, Sven (Rinman). 1782. *Försök till järnets historia, med tillämpning för slögder och handtwerk (Try history of iron, with application for craftsmen)*. Stockholm: Peter Hetzelberg. Translated by Johann Gottlieb Georgi: 1785. *Herrn Swen Rinmann, Königl. Schwed. Bergraths, Directors der Schwarzschiiede, Ritters des Königl. Wasaordens, Mitglieds der Königl. Schwed. Akademie der Wissenschaften... Versuch einer Geschichte des Eisens: mit Anwendung für Gewerbe und Handwerker (History of steel)*. Berlin: Haude & Spener (Zois's books now NUK-GS I 11161/I and NUK-GS I 11161/II). Partial reprint: 1787. *Unterricht von Polieren des Eisens und Stahls für Stahl-Arbeiter / [Sven Rinman]; aus dem Schwedischen übersetzt von D. Caspar Gabriel Gröning*. Flensburg (north Schleswig-Holstein.) & Leipzig: in der Kortenschen Buchhandlung (Zois's book now NUK-GS 0 11256).

Rinmann, Sven (Rinman). 1790. *Anleitung zur Kenntniss der gröbern Eisen und Stahlveredlung und deren Verbesserung von Sven Rinman... aus dem Schwedischen übersetzt*. Wien: Christian Friedrich Wappler (Zois's book now NUK-GS I 11162).

Ritschl, Rudolf. 1931. Über ein Verfahren zur halbdurchlässiger Versilberung von Interferometerspiegeln durch Verdampfen im Hochvakuum. *Zeitschrift für Physik*. Berlin. 69: 578-585.

Robida, Karl (Lucas). 1849. *Naravoslovje alj Fiziko po domače zložil K. Robida učitel (Natural History or Physics for domestic use)*. Ljubljana: Jožef Blaznik.

Robida, Karl. 1853. Entwicklungsgang der Physik von der ältesten Zeiten bis auf die Gegenwart, III

Programm des k.k. Staatsgymnasiums zu Klagenfurt. Am Schlusse des Studien-Jahres 1853. 1-69.

Robida, Karl (Karel Lucas). 1857. Vibrations-Theorie der Elektrizität. VII *Programm des k.k. Staatsgymnasiums zu Klagenfurt (Reports of Grammar school Klagenfurt, Izvestja Gimnazije Celovec)*. Pages 1-37. Review: J. Grailich. 1858. Vibrationstheorie der Elektrizität von Professor K. Robida. *Z. öst. Gym.* 9: 425-427.

Robida, Karl (Karel Lucas). 1858. Magnetismus, Fortsetzung und Schluss der Vibrations-theorie der Elektrizität. VIII *Programm des k.k. Staatsgymnasiums zu Klagenfurt (Reports of Grammar school Klagenfurt, Izvestja Gimnazije Celovec)*. Pages 1-60. Review: J. Grailich. 1859. Magnetismus. Fortsetzung und Schluss der Vibrationstheorie der Elektrizität (Abhandl. des Professor Robida im Programm des Obergymnasiums zu Klagenfurt). *Z. öst. Gym.* 10: 319-321.

Robida, Karl. 1860. *Grundzüge einer naturgemässen Atomistik mit daraus abgeleiteten Schwingungsgleichungen*. Klagenfurt: Druck von Johann Leon.

Robida, Karl. 1861. Erklärung der Lichterscheinungen, XI *Programm des k.k. Gymnasiums zu Klagenfurt. Am Schlusse des Studien-Jahres 1861*. 1-39. Review: Simon Šubic. *Z. öst. Gym.* 12: 320-322.

Robida, Karl. 1862. Erklärung der Beugung, Doppelbrechung und Polarisation des Lichtes. XII *Programm des k.k. Gymnasiums zu Klagenfurt. Am Schlusse des Studien-Jahres 1862*. Pages 1-30.

Robida, Karl. 1863. Grundzüge Einer Molekularphysik und einer mechanischen Theorie der Elektrizität und des Magnetismus. Von Dr. S. Šubic, *Z. öst. Gym.* 14: 463-465.

Robida, Karl (Karel Lucas). 1865. Einige Bemerkungen zur Abhandlung des Prof. Dr. Krönig in Poggendorff's *Annalen der Physik und Chemie* Bd. 123, p. 299 ff.: "Condensation der Luftarten". *Z. Math. Phys.* 10: 227-232.

- Rocke, Alan J. 2001. Aaron Ihde and his students. *Bull. Hist. Chem.*, 26/1: 15-23.
- Röckelein, Hedwig; Bumiller, Casimir. 1990. *Nikodemus Frischlin: ein unruhig Poet Nikodemus Frischlin 1547-1590*. Balingen: Veröffentlichungen des Stadtarchivs.
- Rogner, Johann. 1869. Über Rechenmaschinen. *Mittheilungen des naturwissenschaftlichen Vereines für Steiermark*. XLIII (25 April 1869).
- Rogner, Johann. 1871. *Ueber Johann Kepler's Leben und Wirken*. Festrede den 15. October 1871 bei der Vorfeier des 300-jährigen Geburtstages Kepler's zu Schloss Mühleck nächst Graz gehalten. Graz. 16 pages.
- Rohault, Jacques. 1718. *Physica. Latinè vertit, recensuit, & adnotationibus Ex illustrissimi Isaaci Newtoni Philosophiâ maximam partem haustis, amplificavit & ornavit Samuel Clarke, S.T.P.* London: Jacob Knapton.
- Robinson, Harold Roper. 1962. Rutherford: life and work to the year 1919, with personal reminiscences of the Manchester period. *Rutherford at Manchester* (ed. John Betteley Birks). pp. 53–86. London: Heywood & Co. Reprint: 1963. New York: W. A. Benjamin Inc.
- Röntgen, Wilhelm Conrad. 1898. Ueber eine neue Art von Strahlen. *Ann. Phys.* 64: 1-37.
- Röntgen, Wilhelm Conrad; Franz Serafin Exner. 1874. Über eine Anwendung des Eiscalorimeters zur Bestimmung der Intensität der Sonnenstrahlung. Vorgelegt in der Sitzung am 26 Februar 1874. *Wien. Ber.* II (6th session 26 February 1874), Volume 69: pp. VI, 228-238 with one additional illustration (sent from Strasbourg in December 1873).
- Ross, Ian Munro. 1998. The Invention of the Transistor, *Proc. IEEE*, 86/1 (January 1998) pp. 7-28.
- Rosenberg, Karl. 1902. *Lehrbuch der Physik für Mädchenlyzeen*. Wien: Hölder. Modified reprints: 1903. *Lehrbuch der Physik: für die oberen Klassen der Mittelschulen und verwandter Lehranstalten : mit 615 Tafeln in den Text gedruckten Figuren und einer farbigen Spektraltafel: Ausgabe für Gymnasien*. Wien: A. Hölder (PMSLJ); Reprint: 1915. *Lehrbuch der Physik für die oberen Klassen der höheren Schulen: ausgabe für Realgymnasien, Oberrealschulen, Studienanstalten und Reformanstalten*. 5th bettered edition. Wien/Leipzig: Alfred Hölder.
- Rosenberger, Ferdinand. 1890. *Die Geschichte der Physik in Grundzügen mit synchronistischen Tabellen*. Braunschweig: Druck und Verlag von Friedrich Vieweg und Sohn. Part III.
- Rosner, Robert W. July 2002. Organic Chemistry in the Habsburg Empire Between 1845-1865. *Ambix*. 49/2: 112-126.
- Rosseland, Svein. 1923 (received December 1922, issued 31 January 1923). Zur Quantentheorie der radioactiven Zefallsvorgänge. *Zeitschrift für Physik*. 14: 173-181.
- Rost, Johann Leonhart. 1726. *Astronomisce handbuch* 4to Nürnberg: Monath (NUK-7951, exlibris Joan Dizma Florjančič 1737).
- Pontani, Joanis. 1539. *Liber de meteoris*. Argentorati: Craton Mylius (ST-22/83 109v; NUK-8339). Reprint: 1545... *Cum interpretatione Viti Amerbachii*. Argentorati: Craton Mylius (ST-22/83 109v; NUK -1697).
- Rousseau, Pierre. 1945. *Histoire de la science Texte imprimé*. Paris: Arthème Fayard. Translation: 1955. *Zgodovina znanosti (History of sciences)*. Ljubljana: DZS.
- Rozman, Franc. 1979. *Socialistično delavsko gibanje na slovenskem Štajerskem*. Maribor: Obzorja.
- Rubeus, Alexander de Lugo (Alessandro Rossi da Lugo). 1653. *Totius philosophiae cursus in quo potiores difficultates examinantur atque germana mens Scoti aperitur pars prima [-tertia]*. Auctore P. mag. Alexandro Rubeo de Lugo ord. min con. S.ti Franci olim in Colleg. Sac. Assisiensi et Bononiensi regente ... eminentiss.o principi Io. Stephano cardinali Donghio etc. Three other identically shaped volume printed by the same in the same year

including volumes on controversial theology, morality and: *Controuersiarum metaphysicalium. Inter Scotistas in quibus potiores difficultates examinantur atque germana mens Scoti aperitur tomus vnicus auctore P. mag. Alexandro Rubeo de lugo ord. min con. S.ti Franci ... eminentiss.o principi Io. Stephano cardinali Donghio etc.* Bononiae: Giovanni Battista Ferroni (FSLJ, propriety entries “Joan Stephano Donghio epis(copi) (archbishop of Genoa Giovanni Stefano Donghi), ad usum Jacobi Grrmii/ ad usum fr(atr)is (lector of philosophy) Anton Lazari 1668”).

Rumford, Benjamin. 1802. Essay X. Part I, On the Construction of Kitchen Fire-Places and Kitchen Utensils, together with Remarks and observations relating to the various Processes of Cookery, and Proposals for improving that most useful Art (Part I 1799; Part II 1802). *Essays political, economical, and philosophical*, London: Cadell and Davies. Introduction on pp. 3-21, first part pp. 23-96, second part pp. 97-194, third part pp. 195-384.
Rumford, Benjamin. 1812. *Excellent Qualities of Coffee and the Art of Making it in the Highest Perfection*. Essay XVIII, *Essays political, economical, and philosophical*. London: T. Cadell and W. Davies, 4/18: pp. 153-207.

Rupel, Mirko. 1966. *Slovenski protestantski pisci*. Ljubljana: Državna založba.

Ruscelli, Girolamo (under his pseudonym Alessio Piemontese (Alexius Pedemontanus)). 1555. *De' secreti del reuerendo donno Alessio Piemontese, prima parte, diuisa in sei libri*, Venetia: Sigismondo Bordogna. Johann Jacob Wecker's translation from Italian to Latin Language: 1559. *De secretis libri sex mira quadam rerum varietate referti, ex italico in latinum sermonem nunc primum (De secretis libri VI)*. Basel: Peter Perna.

Ruschitzka, Ludwig. 1985. Die Entwicklung des Eisengusses in Mitteleuropa. *Giessereitechnik*. 31/2: 48-54.

Ruska, Ernst. December 8, 1986 Nobel Speech. Reprint: 1990. The development of the electron microscope and electron microscopy, December 8, 1986. *Nobel lectures, Physics 1981-1990*. Singapore, New Jersey, London, Hong Kong: World Scientific.

Rutherford, Ernest. January-June 1906. Some Properties of the Alpha Rays from Radium, *Phil. Mag.* Series 6, 11/61: 166-176 and plate IV containing three photographs printed after page 19 (sent on November 15, 1905).

Rutherford, Ernest. July-December 1906. Retardation of the Alpha Particle from Radium in passing through Matter. *Phil. Mag.* Series 6, 12/68: 134-146 and plate II containing eight photographs on two pages printed after the texts (sent on June 14, 1906).

Rutherford, Ernest. July-December 1906. The Mass and Velocity of the Alpha Particles Expelled from Radium and Actinium *Phil. Mag.* Series 6, 12: 348-371.

Rutherford, Ernest, Royds, Thomas D. 1909. The Nature of the Alpha Particle from Radioactive Substances. *Phil. Mag.* Series 6, 17: 281-286.

Rutherford, Ernest. 1911. The Scattering of α and β -Particles (Alpha and Beta Particles) by Matter and the Structure of the Atom. *Phil. Mag.* Series 6, 21: 669-688.

Rutherford, Ernest. 1914. The Structure of the Atom. *Phil. Mag.* Series 6, 27: 488-498.

Rutherford, Ernest. 1919. Collision of α Particles with Light Atoms. IV. III. Nitrogen and Oxygen Atoms, *Phil. Mag.* Series 6, 37: 571-580.

Rutherford, Ernest. 1919. Collision of α Particles with Light Atoms. IV. An Anomalous Effect in Nitrogen, *Phil. Mag.* Series 6, 37: 581-587.

Ryff, Walther Hermann (parts published with pseudonyms connected to Tarquinius Schnellenberg, Tarquinius Ocyorus, Quintus Apollinari). 1549. *Kurtz Handbüchlin vnd experiment viler artzneyen, durch den gantzen Körper dess menschen, von dem Haupt bisz auff die füs.: Sampt lebendiger abcontrafactur ethlicher gemeiner kreuter, vnd darauss mancherley gebranten vnd distillierten Gewässer, Krafft und tugenden*. Strassburg: Wendel Rihel. Reprints: 1575. *Kurtzs Handbüchlin und (vnnd) Experiment vieler Artzneyer, durch den*

gantzen Körper des Menschens, von dem Haupt biss auff die Füßs; Sampt lebendiger Abcontrafactur etlicher gemeiner Kreutter, vnd darauss mancherley Gebranter vnd Distillierten Wassern, Krafft vnd Tugendt; Durch den Hochgelehrten Q. Appollinarem, selbs erfahren vnnd beweret.
Strassburg: Josia Rihel (NUK-GS 0 11538); 1578.
Strassburg: Rihel (SAZU-78042/1); 1659. Straßburg: Jonas Städel (KSSKL).

Ryssel, Heiner; Ruge, Ingolf. 1986. *Ion implantation*. Chichester: John Wiley & Sons.

Sabaz-Deranja, Loredana. 1994/95. *Vecchi mezzi didattici del laboratorio di scienze: un museo scolastico*. Capodistria: Ginnasio Gian-Rinaldo Carli.

Sabaz, Loredana (ed.). 2008. *L'insegnamento della fisica nell'ottocento a Capodistria: la storia, la scuola, il contesto europeo, il museo scolastico*. Koper/Capodistria: Ginnasio Gian Rinaldo Carli.

Sadron, Charles; Paul Couderc; Louis de Broglie (eds.). *Célébration du centenaire de la naissance de Jean Perrin*, Paris: Presses Universitaires de France (PUF)/Comité D'Organisation Du Centenaire De Jean Perrin.

Sah, Chih-Tang. Oct. 1988. Evolution of the MOS Transistor-From Conception to VLSX. *Proc. IEEE*. 76/10: 1280-1326.

Sahulka, Johann. 1890. Bestimmung des mechanischen Aequivalentes der Wärme aus der Wärmeausstrahlung. *Annalen der Physik*, 277/12: 748-755.

Saito, Fumikazu (齋藤文一). 2006. O Vácuo de Pascal Versus o Ether de Noël: Uma Controvérsia Experimental? (The vacuum of Pascal versus the ether of Noël: an experimental controversy?) *Circumscribere: International Journal for the History of Science* (Rio de Janeiro & Pontifícia Universidade Católica de São Paulo (PUC-SP) in Portuguese language). 1: 50-57.

Samec, Maks (Translator); Turgenjev, Ivan Sergeevič (*Dym*). 1870. *Dim: roman*. Graz: M. Samec self-publishing.

Samec, Maks. 1871. Črtica o vplivu podnebja na človeški organizem in razvitje njegovih bolezni. *Letopis Slovenske Matice leto 1871*, 2nd part: *Znanstvene razprave*. Ljubljana: Slovenska matica. 221-238.

Samec, Maks. 1871. Spektralna analiza. *Letopis Slovenske Matice leto 1871*. Ljubljana: Slovenska matica, 2nd part: *Znanstvene razprave*. 257-282 (17 illustrations).

Samec, Maks. 1876. Možgani. *Letopis Slovenske Matice leto 1876*. Ljubljana: Slovenska matica.

Samec, Maks. 1939. Paper on 50th anniversary of his death, *Jutro*. (Ljubljana, ed. Stanko Virant), Sunday, 20 August 1939. Volume 20, number 193.

Samec, Maks (Maksimilian, junior). 1905. Durchsichtigkeit der Luft bei Verschiedenen Witterungszuständen. *Wien.Berichte*. Ila 114: 1519-1568.

Samec, Maks; Blinc, Marta. 1936. Die Quellstärken. *Kolloid-Zeitschrift*. 77: 134-140.

Sangalli, Maurizio. 2001. Università *Accademie Jesuiti. Cultura e religione a Padua tra cinque e seicento*. Padova: Edizioni Lint.

Sannig, Bernard. 1684. *Schola philosophica scotistarum seu cursus philosophicus completus, ad mentem Doctoris Subtilis Joannis Duns Scoti*. Tomus 1. Vetro-Pragæ: typis Catharinæ Czernochianæ viduæ. Continuation by Parts 2-3: 1685. *Schola philosophica scotistarum: seu Cursus philosophicus completus ad mentem doctoris subtilis Joannis Duns Scoti [...]. Tomus II, continens Tractatum in octo libros Physicorum, Tractatum de fabrica mundi et coeli, Tractatum de elementis, Tractatum de generatione et corruptione, aliisque motibus. Tomus III.: Continens Tractatum in Libros de Anima. Tractatum in Universam Metaphysicam. Tractatum de Meteoris. Tractatum de Geographia. Tractatum de Physionomia. Tractatum de Horographia, seu Horologiis*. Tomus 1-3. Neo-Pragae: typis Joannis Nicolai Hampelij (Jan Mikuláš Hampel) (FSLJ-19 a 22).

- Santorio, Santorio. 1614. *De medicina statica*. Venezia. 3rd print: 1634. *Ars... de statica medicina et de responsione ad staticomasticem*. *Aphorismorum sectionibus septem comprehensa*. Venezia: Marc'Antonio Brogiollo (12^o, 125 x 66 mm, bought later in London for Osrednja knjižnica Srečka Vilharja - Biblioteca centrale, Koper). Reprint: 1660. *Opera omnia*. Venezia: Francisco Borgiollo.
- Santorio, Santorio. 1625. *Commentaria in primam seu primi libri Canonis Avicennae*. Venezia: Apud Iacobum Sarcinam (Jacopo Sarcina).
- Savery, Servington. 1729/1730. *Magnetical Observations and Experiments; By Servington Savery, Esq; Of Shilston*. *Phil. Trans.* (London), 36: 295–340
- Sawyer, William Edward. 12 June 1880. Seeing by electricity (letter to the editor as reply to George R. Carey's claims a week earlier). *Sci. Am.* 42/24: 373.
- Schaschl, Josef. 1886. Die Galvanostegie, mit besonderer Berücksichtigung der fabrikmässigen Herstellung dicker Metallüberzüge auf Metallen mittelst der galvanischen Stromes. *Elektro-technische Bibliothek*, 30. Bd. (volume 30) Wien: Hartleben & F. Vieweg & Sohn.
- Schaschl, Josef. 1893. Der Westinghouse-Motor. *Mittheilungen aus dem Gebiete des Seewesens* (Pula: Karl Gerold Sohn), Beilage (supplement). 21/4–5: 1–20.
- Schedel, Hartmann; George Alt (translator). 1493. *Weltchronik*. Nuremberg: Anton Koberger.
- Scheitz, Benno. 1878. Nekrologe. Professor Karl Robida. *Programm des Staats-Obergymnasiums zu Klagenfurt*. 53-56.
- Scherffer, Karl. 1752. *Institutionum Physicae*. Vindobonae: Trattner (MINSPT; FSLJ-11 g 25-26). Reprints: 1753. *Institutionum Physicae*. Vindobonae: Trattner; 1763. *Institutionum Physicae (Pars prima et secunda) pars prima cont. physicam generalem in usum tironum conscripta. Pars secunda vero physicam particularem, conscripta in usum tironum philosophiae*. Vindobonae: Trattner (NUK-8485; FSLJ-6 d 24 (pars secunda) with ex libris “probatie 1763”); 1768. *Institutionum Physicae*. Vindobonae: Trattner; 1769. *Institutionum Physicae*. Vindobonae: Trattner.
- Scherffer, Karl. 1770. *Institutionum Analyticarum pars prima, sive analysis quantitatum finitarum Conscripta In Usum Tironum A P. Carolo Scherffer (Pars secunda de calculo infinitesimali.)*. 1-2. Vindobonae: Trattner (FSLJ-7 b 54).
- Scherffer, Karl. 1773. *Institutionum mechanicarum / Pars prima sive de motu, et aequilibrio corporum solidorum in usum tironum / Pars secunda sive de motu, et aequilibrio corporum fluidorum in usum tironum*. Vindobonae: Trattner (NUK-4225).
- Schiffer, Michael Brian. 2003. *Draw the Lighting Down. Benjamin Franklin and Electrical Technology in the Age of Enlightenment*. Berkeley/Los Angeles/London: University of California Press.
- Schimank, Hans; Guericke, Otto. 1968. *Otto von Guericke's Neue (sogenante) Magdeburher Versuche...* Düsseldorf: VDX.
- Schiviz von Schivizhoffen, Ludwig. 1904. *Der Adel in den Matriken der Grafschaft Görz und Gradisca*. Gorizia (Görz, Gorica): published by Johan Logar, printed by Karl Gerold's son in Vienna.
- Schiviz von Schivizhoffen, Ludwig. 1905. *Der Adel in der Herzogthum Krain*. Gorizia (Görz, Gorica): self-publishing (Selbstverlag des Verfassers), printed by Goriška Tiskarna« of A. Gabršček in Gorizia.
- Schneider, Karl Christoph. 1832. *Geschichte der Alchemie*, Halle: Waisenhaus.
- Schmidt, Gustav Johann Leopold. 1860. Ein Beitrag zur Mechanik der Gase. *Wien.Ber.* 39: 41-104 with additional double page table following page 104 comparing Redtenbacher and Clausius's *Ann.Phys.* volume 100 data of density and specific heats of gases obtained by evaporation at the state of saturation (Die Verdampfung und die Vorstellung des Sättigungszustandes). Read at session on 12 May 1859, accepted at session on 5 January 1860.

Schmidt, Gustav Johann Leopold. 1861. IV. Uiber (Über) den Unterschied der Aequivalent-Capacität in festen und gasförmigen Verbindungen. Von Gustav Schmidt, k. k. Kunstmeister und Docenten des Maschinenbaues. *Berg- und hüttenmännisches Jahrbuch der K.K. Montan-Lehranstalten zu Leoben und Příbram* und der k. k. Bergakademie zu Schemnitz (als Fortsetzung des Jahrbuches der k.k. Montan-Lehranstalten zu Leoben (continuation of Yearly of Mining Academy of Leoben). For the year 1860, 10: 226-243. Wien: Tendler (Pöbelberger & Fromme), printed in Prague by Gottlieb Haase's son (ed. director in Příbram Johann Grimm for his Kaiserlich-Königliche Montan-Lehranstalt in Příbram). Separate print: 1861. Prague.

Schmidt, Gustav Johann Leopold. 1861. *Theorie der Dampfmaschinen*. Freiberg: J.G. Engelhardt. 272 pages. Abridged version: 1862. Ueberblick der verschiedenen Turbinentbeorien. *Berg- und hüttenmännisches Jahrbuch der k. k. Bergakademien zu Leoben und Schemnitz und der k.k. Montan-Lehranstalten Příbram* (als Fortsetzung des Jahrbuches der k.k. Montan-Lehranstalten zu Leoben). For the year 1861, 11: 94-124.

Schmidt, Gustav Johann Leopold. 1861. Ueber die Dichte des Wasserdampfes. *Zeitschrift des österreichischen Ingenieur-Vereins*. p. 65. Reprint: 1861. *Dinglers Polytechnisches Journal*. 160/80: 262-266.

Schmidt, Gustav Johann Leopold. 1863. Von Schiebergebläse zum Bessemeren (From slide-valves to Bessemer). *Berg- und hüttenmännisches Jahrbuch der k. k. Bergakademien zu Leoben und Schemnitz und der k.k. Montan-Lehranstalten Příbram* (als Fortsetzung des Jahrbuches der k.k. Montan-Lehranstalten zu Leoben). For the year 1862. 12: 147-154.

Schmidt, Gustav Johann Leopold. 1865. Über die Atomwärme. *Wien.Ber.* 52: 417-452 (accepted at session on 19 October 1865). Noted at: 1866. *Z.Math.Phys.* 11: 28.

Schmidt, Gustav Johann Leopold (anonymous). 1871. Wärme-Capacität der Gase, *Dinglers Polytechnisches Journal* 200/8: 19-21 (criticism of knight Schwind's Begriff der Wärmecapacität bei

constantem Druck (ideas of capacity by constant pressure) published in *Dinglers Polytechnisches Journal* 199: 229). Anonymous Countercriticism: 1871. *Dinglers Polytechnisches Journal*, 200/Miszelle/3: 153-154.

Schmidt, Gustav Johann Leopold. 1879. Eine Versündigung gegen mechanische Wärmetheorie (A sin against mechanical theory of heat). *Dinglers Polytechnisches Journal*. 232: 374-377 with illustrations criticizing Joseph Frederic Klein's formulation of Carnot's entropy law.

Schmidt, Gustav Johann Leopold. 1879. Ueber die relative Raumerfüllung der Gase. *Ann.Phys.* 242/4: 612-615.

Schmidt, Gustav Johann Leopold. 1880. Zustandsgleichung der atmosphärischen Luft. *Ann.Phys.* 247/9: 171-176 (Leipzig: J.A. Barth).

Schmidt, Gustav Johann Leopold. 1883. Über die innere Pressung und die Energie überhitzter Dämpfe, *Wien.Ber.* 86: 417-452.

Schmidt, Vlado. 1963. *Zgodovina šolstva in pedagogike na Slovenskem*. 1st part. Ljubljana: DZS.

Schneider, Ditmar. 1986. Auf den Spuren Guericke's. *Phys. Bl.* 42: 397-399.

Schnell, Anselm. 1737. *Cursus Philosophiae Aristotelico-Thomisticae Abbreviatus: Id est, Tractatum Philosophicorum omnium Summa, Seu Compendium, Quod In usum Philosophiae Studiosorum, Repetitorum. &c. imo & ipsorum Professorum, aliorumque Philosophorum commodum è suis Praelectionibus nuper fusius traditis collegit. P. Anselmus Schnell, O. S. B: etc. Pars I. Complectens Tractatum praeliminarem in Logicam parvam seu Summulas, et V. Tractatus in Logicam magnam. Pars II. Complectens Tractatus V in Physicam universalem, agente de corpore naturali in genere. Pars III Complectens Tractatus tres in Physicam Particularem, & Tractatum in Methaphysicam*. 1-3. Augustae Vindelicorum: Strötter & Anton Maximil Heiss (FSLJ-15 d/a 80; NUK-GS 4445). Reprint: 1744. Augustae Vindelicorum: Mauracher (NUK-GS 5238).

Schoedler, Friedrich. 1850. *Das Buch der Natur*. Braunschweig: von Friedrich Vieweg und Sohn. Reprint: 1865. *Das Buch der Natur, die Lehren der Physik, Astronomie, Chemie, Mineralogie, Geologie, Botanik, Physiologie und Zoologie umfassend: allen Freunden der Naturwissenschaft, insbesondere den Gymnasien, Real- und höheren Bürgerschulen gewidmet: in zwei Theilen / I Physik, physikalische Geographie, Astronomie und Chemie. Von Friedrich Schoedler, Director der Großherzogl. Hess. Provinzial-Realschule in Mainz*. Braunschweig: Vieweg. Translations: 1854. *Il libro della natura: comprendente sei trattati di fisica, astronomia, chimica, mineralogia, botanica e zoologia. Trattato I, Fisica / del D.re Fed. Schoedler; prima versione italiana di Angelo Cavalieri eseguita sulla sesta edizione del 1852, migliorata ed accresciuta*, Trieste: Tipografia del Lloyd Austriaco (POMPI); Translated by Tušek, Ivan: 1869. *Fizika*. Ljubljana: SM.

Schöner, Johann; Gemma, Frisius. 1548. *Gemma Phrysius De principiis astronomiae & cosmographiae, deque vsu globi cosmographici ab eodem editi, de orbis diuisione & insulis, rebusq[ue] nuper inuentis; eiusdem de annuli astronomici vsu. Ioannis Schoneri de vsu globi astriferi opusculum*. Antverpiae: Ioan. Steelsii (FSLJ-17 d 56).

Schopman, Joop. 1988. Industrial science: Semiconductor research at NV Philips' Gloeilampenfabrieken, 1930-1957. *HSPS*. 19/1: 137-172.

Schott, Gaspar. 1657. *P. Gasparis Schotti Mechanica hydraulico-pneumatica qua praeretur quòd aquei elementa natura, proprietas, vis motrix, atque occultis cum aëre conflictus, à primis, fundamentis demonstratur: omnis quoque generis experimenta Hydraulico-pneumatica recluduntur: & absoluta machinarum aquâ & aëre animandarum ratio ac methodus praescribitur: opus bipartitum, cujus Pars I., Mechanicae hydraulico-pneumaticae theoriam continet: Pars II, Ejusdem praxin exhibet, machinasque aquarias innumeras, uti & organa, aliaque instrumenta, in motum as sonum concitat: nec non varia technasmata, quae motum perpetuum v aquae spondent, exponit: accessit experimentum novum Magdeburgicum, quo vacuum alij stabilire, alij evertere conantur*. Francoforti ad Moenum:

sumpt. Heredum Joannis Godefridi Schönwetteri excudebat Henricus Pigrin Typographus Herbipoli (Auersperg's book, Valvasor's book; NUK-GS 4158 bind to Schott's 1660. *Pantometrum Kircherianum*. Herbipoli: Hertz (NUK-GS 4092)). Reprints: 1658-1659. Francoforti ad Moenum/Würzburg: sumpt. Heredum Joannis Godefridi Schönwetteri excudebat Henricus Pigrin Typographus Herbipoli.

Schott, Gaspar. 1657. *Magiae universalis naturae et artis* (Auersperg's Book). Reprint: 1658. *Magiae universalis naturae et artis. III-IV*. Herbipoli: Hertz. Reprint in German translation: 1677. Bambergae: Joh. Martin Schönwetter (Valvasor owned volumes 1, 3 and 4; J-605 now NUK-8525 without propriety entry).

Schott, Gaspar. 1663. *Anatomia physico-hydrostatica fontium ac fluminis libris VI explicata ... accedit in fine appendix de vera origine Nili*, Würzburg: Schönwetter (FSLJ, Valvasor's book).

Schott, Gaspar. 1664. *Technica curiosa, sive mirabilia artis libris XIX Comprehensa; quibus varia experimenta, variaque technasmata pneumatica, hydraulica, hydrotechnica, graphica, cyclometrica, chronometrica, automatica, cabalistica aliaque artis arcane ac miracula, rara et antehac inaudita eruditi orbis utilitati, delectationi disceptationique proponuntur. Pars I. II*. Herbipoli: Hertz (Auersperg's book; Valvasor's book). Reprint: 1687. Herbipoli: Endter (NUK-GS 8347).

Schott, Gaspar. 1671. *Magia optica...* 4 (1st part *Magia Universalis Naturae et Artis*. Bamberg: Johann Martin Schönwetter (ST). Jesuitical German translation of *Magia universalis naturae et artis*: 1677. *Magia Optica das ist Geheime doch naturmässige Gesicht- und Augen-Lehr : in zehen unterschiedliche Bücher abgetheilet...* Frankfurt: Schönwetter (Valvasor's book); Reprint: 1677. *Magia universalis naturae et artis*, Bamberg: Johann Martin Schönwetter (Auersperg's book).

Schott, Gaspar. 1662. *Physica curiosa*, 1-2, Herbipoli (Würzburg): Sumptibus Johannis Andrea Endter & heirs of Wolfgang Jun, Excudebat Job Hertz (Auersperg's book). Reprints: 1664. *Physica curiosa, seu mirabilia naturae et artis*. Herbipoli:

Endter; 1667. Herbiopoli: Endter (Valvasor's book; NUK-GS 8192); 1697. Herbiopoli: excudit Jobus Hertz sumptibus Wolfgang Mauriti Endter (SKLJ-SK T II 1 č).

Schott, Gaspar. 1739. *Magia pyrotechnica. Promoted Anton Weilhamer (as part of Magia Universalis Naturae et Artis)*. Viennae: Widow Mariae Theresiae Voigt (NUK-GS 5471).

Schöttl, Gregor, Maffei, Joseph, Tschokl, Anton (Čokl). 1775. *Tentamen Philosophicum ex logica, metapyhsica (= metaphysica); algebra, geometria, trigonometria, geodesia (=Geodesy), stereometrissa (sic!), geometria curvarum, balistica et physica, tam generali, quam particulari, quod anno MDCCLXXV. mense augusto die in archid.academia Labacensi. Ex praelectionibus adm.r. ac.cl.d. Georgii Schöttl, of physics Professor publ. et ord. adm. r. cl. ac perill. d. Josephi Maffei de Glattfort, of mathematics profes. publ. et ord. adm. r. ac cl. d. Antonii Tschokl, of logics et metaphysics Professor publ. et ord. subivere. Perd. d.Fidelius Poglajn, Carn. Crainb. Perd. D. Georg. Veha, Carn. Moraitsch. Perd. d. Mathaeus Kallan, Carn. loco pol. e sem. episc. alum. Schiffer. Labaci (NUK-8272).*

Schramm, Heinrich. 1872, 1873. *Die allgemeine Bewegung der Materie als Grundursache aller Naturerscheinungen (The general movement of matter as the basic cause of all Phenomena in Nature)*, 1-2. Wien: Wilhelm Braumüller. Presented at 27th meeting of the Viennese Imperial Academy of Sciences Mathematical and natural science class on December 5, 1872, *Wien. Ber.* p. 199.

Schramm, Heinrich. 1873. Die Anziehungskraft betrachtet als eine Wirkung der Bewegung. *VIII. Jahresbericht der n. ö. Landes-Oberrealschule zu Wiener Neustadt pro 1873*. Also, a simultaneous separate print (Separatabdruck aus dem *Jahresbericht*): 1873. Wien: Carl Finsterberg, 12 pages.

Schreiner, Henrik. 1889. *Physics or the science of nature with special regard to the needs of farmers (Fizika ali nauk o prirodi s posebnim ozirom na potrebe kmetskega stanu)*. Klagenfurt: Society of St. Mohor (Hermagor, Celovec: Družba sv. Mohorja).

Schrey, Thomas. 1876. *Höhenmessungen in Kärnten. Nach den Gebirgs- und Flussgebieten geordnet und in Metermesse angegeben*. Klagenfurt: Leon.

Schrey, Thomas. 1897 Schwaches Erdbeben in Stift Griffen (Sic! the right spelling Griffen (Grebinj) in the Carinthian district of Völkermarkt), In: *Chronik Der Erdbeben Im Jahre 1897* (ed. Mojsisovics (Mojsisović), Johann August Georg Edmund. *Mittheilungen Der Erdbeben-Commission*, 1898, p. 258.

Schröder, Wilhelm baron von. 1684. *Wilhelm Freyherrn von Schr. aus der Royal Societät von Engelland Nothwendiger Unterricht vom Goldmachen, denken Buccinatoribus oder so sich selbst nennenden foederativ hermeticis auf drei Epistel zur freundlichen Nachricht*. Leipzig: Jakob Gerdesius (Freyer's transcript in SI_AS 863, printed version not preserved in Slovenian libraries). Similar publications: Schröder, Wilhelm baron von. 1680. Leipzig. Reprint: 1721. *Wilhelm Freyh. von Schrödern Fürstliche Schatz- und Rent-Cammer: nebst seinem Tractat vom Goldmachen wie auch vom Ministrissimo or Ober-Staats-Bedienten*. Leipzig: Th. Fritsch (Freyer's transcript in SI_AS 863, printed version now catalogued as NUK-GS 22238).

Schröter, Fritz Georg Ernst. 1930. Die Braunsche Röhre als Fernseher. *Fernsehen*. 1: 4-8.

Schröter, Fritz Georg Ernst. 1930. Aus der Entstehungsgeschichte der Glimmlampe. *Fernsehen*. 1: 244-249.

Schröter, Fritz Georg Ernst. 1932. *Handbuch der Bildtelegraphie und des Fernsehen, bearbeitet und herausgegeben von F. Schröter*. Berlin: Verlag von Julius Springer.

Schröter, Fritz Georg Ernst (editor). 1937. *Fernsehen*. Berlin: Julius Springer.

Schröter, Fritz Georg Ernst. 1956. *Fernsehtechnik*. Volume 1: *Grundlagen des elektronischen Fernsehens* (ed. F. Schröter, processed-authored by him, Richard Theile, and Georg Wendt); volume 2: *Technik des elektronischen Fernsehens* (ed.

- Schröter, Fritz). Berlin: Springer. Series Title: Lehrbuch der drahtlosen Nachrichtentechnik (Textbook of Wireless Telecommunications), ed. Nicolai von Korshenewsky & Wilhelm T. Runge, Volume 5.
- Schulz von Strassnitzki, Karol. 1827. *Das geradlinige Dreieck und die dreiseitige Pyramide nach allen Analogie dargestellt*. Wien: J. G. Heubner.
- Schulz von Strassnitzki, Karol. 1835. Beiträge zur Discussion des Eulerschen Lehrsatzes von Polyëdern in Beziehung auf die neulich bemerkten Ausnahmen desselben. *Journal für die reine und angewandte Mathematik* (Berlin, ed. A.L. Crelle). 14/1: 83-87 including table I containing figures 6-9.
- Schröer, Karl Julius. 1870. *Wörterbuch der Mundart von Gottschee*. Wien: Gerold (k.k. Hof- und Staatsdruckerei).
- Schüler, Hermann (Schuler); Gollnow, Heinz. 1938. Über die Verteilung der Rotationszustände bei einem Elementarprozeß der Molekülbildung (keine Boltzmann-Verteilung) und die Änderung der relativen Übergangswahrscheinlichkeit, *Zeitschrift für Physik A Hadrons and Nuclei*, 108/11-12 (193811): 714-725; 109/5-6 (May 19380501): 432-432.
- Schumi, Franz (Šumi, Franc). 1882. Die Ansiedlung in Gottschee, *Archiv für Heimatskunde Geschichtsforschungen, Quellen, Urkunden und Regesten, Urkunden- und Regestenbuch des Herzogtumes Krain* (ed. Schumi, Franz in Ljubljana). 1: 30-31.
- Schwartz, George; Bishop, Philip W. (eds.). 1958, 1959. *Moments of discovery*, New York: Basic Books.
- Schwarz, Heinrich. 1879. Zur Philosophie der Technik. *Mittheilungen des naturwissenschaftlichen Vereines für Steiermark*. LXV-LXX.
- Schwarzer, August. 1859. Die Grundzüge der dynamischen Wärmetheorie mit Rücksicht auf ihre Entwicklung. *Drittes Programm der ersten k.k. deutschen Ober-Realschule in Prag veröffentlicht am Schlusse des Schuljahres 1859*. Prag: K.k. deutsche Ober-Realschule, Statthalterei-Druckerei. Pp 19-43.
- Schwarzer, August. 1871. Ueber die maassanalytische Bestimmung des Eisenoxyds mittelst Jodkaliums. *Journal für Praktische Chemie* (new series) 3/1 (18710120): 139-143. Reprint: 1 December 1872. *Carl Remigius Fresenius' Zeitschrift für Analytische Chemie (Bericht Über Die Fortschritte Der Analytischen Chemie, Wiesbaden)*. 11 (1): 74-77.
- Schweber, Silvan Samuel; Treiman, Sam Bard. December 1994. QED and the Men Who Made It: Dyson, Feynman, Schwinger and Tomonaga. *Phys. Today* 47/12: 59-60.
- Schwenter, Daniel; Harsdörffer, Georg Philipp. 1636. *Daniel Schwenter... Deliciae mathematicae et physicae, oder, Mathemat. Und philosophiche Erquickstunden darinnen sechs-hundert drey und sechsig schöne, liebliche und annehmliche Kunststücklein*. Nürnberg: Dümler (S). Continuations: 1651, 1653. Second and third Harsdörffer's parts. Nürnberg (S; NUK-4154); Reprints: 1677. Nürnberg: Endter (NUK-5062); 1651-1653. Nürnberg: Dümler (FSNM).
- Scocchi, Angelo. 1926. *Guglielmo Oberdan, tra maestri amici e compagni a Trieste e a Vienna: la sua educazione spiritual*. Trieste: Casa Editrice Adratica.
- Seebeck, Thomas Johann Seebeck. 1810. Wirkungen farbiger Beleuchtung. In: Goethe's *Zur Farbenlehre*. Geschichte der Farbenlehre. The second volume. The first historical part (Des Zweyten Bandes. Erster, historischer Theil) entitled Materialien zur Geschichte der Farbenlehre. Pp. 703-724 at final pages before index of names (Namenregister).
- Segrè, Emilio. 1986. *Von den fallenden Körper zu den elektromagnetischen Wellen*. München/Zürich: Piper.
- Seifert, Gotthard; Köhler, Thomas; Tenne, Reshef. 2002. Stability of Metal Chalcogenide Nanotubes. *J.Phys.Chem. B* 106/10: 2497-2501.

- Seifert, Herbert. 1988. *Der Sig-prangende Hochzeit-Gott. Hochzeitsfeste am Wiener Hof der Habsburger und ihre Allegorik 1622-1699*. Wien: Musikwissenschaftliche Verein.
- Sekulić, Martin. 1871. Fluorescencija i calcescencija. *Rad.* 15: 77-86.
- Sekulić, Martin. 1872. Polarna zora kao učinak zemaljske munjine. *Rad.* 20: 39–60.
- Sekulić, Martin. 1872. Ultraviolette Strahlen sind unmittelbar sichtbar. *Chemisches Zentralblatt (Central-Blatt)*. 43/3: 417–418.
- Sekulić, Martin. 1873. Eine merkwürdige Interferenzerscheinung. *Annalen der Physik*. 225/5: 126–128.
- Sekulić, Martin. 1874. Fizika atoma i molekula. *Rad.* 26: 109–152.
- Sekulić, Martin. 1874. Burnjak. Izumio i preračunao M. S. *Rad.* 27: 69–76 with illustrations on pp. 225-226.
- Sekulić, Martin. 1875. Über die an bestäubten und unreinen Spiegeln sichtbare Interferenzerscheinung. *Annalen der Physik*. 230/2: 308–316.
- Sekulić, Martin. 1877, 1879, 1881. Uzrok munjotvornoj sili. *Rad.* 41: 105–121, 50: 1–31, 58: 171–190.
- Sekulić, Martin. 1878. Beziehungen zwischen der elektromotorischen Kraft und der chemischen Wärmetönung. *Anzeiger der Kaiserlichen Akademie der Wissenschaften*, volume 15/ session no. 16: page 129, presented-noted by the secretary J. Stefan as second article at session on 22 June 1878, but left unpublished in Vienna besides the title.
- Sekulić, Martin. 1878. Elementarni nauk o harmoničnom titranju, Priredio za više razrede srednjih škola. *Izveštje c. k. vel. realke u Rakovcu za g. 1877/8* (Jahresbericht der k. k. Ober-Realschule in Rakovac im kroat. Grenzlande für das Schuljahr 1877/8. Agram (Zagreb). 24-42.
- Semery, Andreas. 1674. Roma: Nicolò Angelo Tinassi. Reprints: 1682. Romae: Caesaretti; 1688. Coloniae: Bencard; 2nd edition recognized by author: 1690. *Triennium Philosophicum quod P. Andreas Semery Remus e Societate Jesu in Collegio Romano Philosophiae iterum Professor Dictabat Qu. Ac Editione ab Authori Recognitum & Auctum. Annus primus; Annus Secundus*. Venetiis: Baptistae Tramontini & D. Rocchi (NUK-4449, 2nd edition; KSSKL-Loka S 25); 4th edition: 1708. *Triennium philosophicum, quod P. Andreas Semery Remus e societate Jesu in Collegio Romano Philosophiae iterum Professor dictabat. Quarta hac editione ab Authore recognitum et auctum. Annus secundus et tertius*. Venetiis: Joseph de Angelis (FSLJ-7 e 49-51; NUK-5188 ex libris of Ljubljana Barefoot (Disalced) Augustinians).
- Senechal, Majorie. 1995. *Quasicrystals and Geometry*. Cambridge: University Press.
- Senekovich, Andrej. 1883. Impressions from the Viennese Electrical Exhibition. *Ljubljanski Zvon*. 720-727, 790-795.
- Serše, Saša. 2000. Začetki obrtnega šolstva na Kranjskem v obdobju 1750–1850. *Archives (Arhivi)* 22/2: pp. 41–46.
- Sevnik, Roman. 1988. Steinberg (Stemberg), Franc Anton (keyword), *Primorski slovenski biografski leksikon* (ed. Martin Jevnikar) 14: pp. 458–459.
- Shank, John Bennett (University of Minnesota in Morris). 2008. *The Newton Wars and the Beginning of the French Enlightenment*, University of Chicago Press.
- Shapin, Steven; Schaffer, Simon. 1985. *Leviathan and the Air Pump. Hobbes, Boyle, and the Experimental Life*. New Jersey: Princeton University Press. French translation. 1993. Paris: Éditions de Découverte.
- Shaw, Trevor Royle. 2001. Bishop Hervey at Trieste and in Slovenia, 1771 = Bishop Hervey v Trstu in Sloveniji 1771. *Acta carsologica* 30, no. 2, pp. 279–291.

- Shockley, William Bradford, Pearson, Gerald L. 15 June 1948. Modulation of Conductors of Thin Films of Semi-Conductors by Surface Charges. *Phys. Rev. Lett.* 74/2: 232-233.
- Shockley, William Bradford. 1950. *Electrons and Holes in Semiconductors*. New York: D. van Nostrand Company Inc.
- Shockley, William Bradford, Sparks, Morgan, Teal, Gordon Kidd. 1951. p-n (pn) Junction Transistors, *Phys. Rev.* 83/1 (July 1, 1951): 151–162.
- Shockley, William Bradford. January 1998. Semiconductor Amplifier patent (Semiconductor Amplifiers, patented Apr. 4, 1950, (Shockley's) USA patent office no. 2,502,488). *Proc. IEEE.* 86/1: 34-36 (reprint).
- Sichen, Willem Van (Guillaume). 1666. *Integer cursus Philosophices. Brevi, Clara Et Ad Docendum Discendumque Facili Methodo Digestus. 1-2, Tomus 1, Complectens Logicam & Metaphysicam; Tomus Secundus Complectens Physicam, Auctore F. Guilielmo Van Sichen, Ordinis Fratrum Minorum Regularis Observantiae in Academia Lovaniensi Sacrae Theologiae Lectore*. Antverpiae: Petrus Bellerus (FSLJ-10 a 8 bind (ad ligate) to FSLJ-10 a 30).
- Sichen, Willem Van (Guillaume). 1671. *Homologia de statu naturae purae, lapsae et reparatae, quam ... praeside F. Guilielmo Van Sichen, ... defendet Fr. Andreas Van Houten, ... Lovanii, conventu fratrum minorum Recollectorum, die 25. Augusti*. Lovanii: M. Halleparde (FSLJ-10 a 30 ad ligate).
- Sidot, Théodore. 23 July 1866. Chimie. Sur les propriétés de la blende hexagonale, note de M.T. Sidot, présentée par M. Edm. Becquerel. *Comptes rendus.* 63 (July-December): 188-189.
- Sidot, Théodore. 1868. Chimie - Sur la préparation de sulfures de fer et de manganèse, note de M. Sidot, présentée par M. Edm. Becquerel, *Comptes rendues.* 66/25 (1st semestre, January-June): 1257-1258.
- Siemens, Georg. 1957. *History of the house of Siemens*. 1-2. Freiburg / Munich: Karl Alber.
- Siemens, Ernst Werner. 1889, 1891. *Wissenschaftliche und technische Arbeiten*. 1-2. Berlin: Julius Springer.
- Sienell, Stefan. 2001. *Die geheime Konferenz unter Kaiser Leopold I Personelle Strukturen und Methoden zur politischen Entscheidungsfindung am Wiener Hoff*. Frankfurt am Main: Peter Lang.
- Sigaud de La Fond, Joseph Aignan. 1785. *Anweisung zur Experimentalphysik*. 2 Bände (Volumes). Wien: Trattner.
- Sigmund, Peter. 1981. Theoretical Concepts. *Sputtering by Ion Bombardment* (ed. Rainer Behrisch). Berlin, Heidelberg, New York: Springer-Verlag.
- Simonič, Ivan. 1939. Kočevsko ozemlje (zemljepis in zgodovina). Zgodovina kočevskega ozemlja. *Kočevski zbornik*. Ljubljana: vodstvo Družbe sv. Cirila in Metoda v Ljubljani. 45-130.
- Simonič, Ivan. 1956. Zgodovina kočevskega ozemlja od naselitve do leta 1941. In: *Kočevsko: zemljepisni, zgodovinski in umetnostno-kulturni oris kočevskega okraja : vodnik z adresarjem* (ed. Bogomil Gerlanc). Kočevje: Turistično olupševalno društvo.
- Simoniti, Primož. 1974. Med knjigami iz stare gornjegrajske knjižnice (Among books in old library of Upper Castle), *Zbornik Narodne in univerzitetne knjižnice (Anthology of library NUK)*. Ljubljana: NUK, 17–48.
- Simoniti, Primož. 2007. *Med humanisti in starimi knjigami (Among humanists and old books)*, Ljubljana: Slovenska matica.
- Simony, Oskar. 1873-1875. Grundzüge einer neuen Molekulartheorie unter Voraussetzung Einer Materie und Eines Kraftprincipes, *Z.Math.Phys.* 18/1 (1873): 463-510 with figures 8-10 on table 6, 19 (1874): 298-323; 20 (1875): 177-211.
- Simony, Oskar. 1880. Über eine Erweiterung der Giltigkeitsgrenzen einiger allgemeiner Sätze der Mechanik. *Wien. Ber.* II. 81/2: 399-414.

Sime, Ruth Lewin. 1998, Lise Meitner and the Discovery of Nuclear Fission. *Scientific American*. Vol. 278, No. 1 (January 1998), pp. 80-85.

Sirk, Hugo. 1909. Versuche über kathodische Ausfällung der Thoriuminduktion aus ihren salzsauren Lösungen, *Wien. Ber.* 118 (29 April 1909) pp. 363-371.

Sirk, Hugo; Doelter, Cornelius. 1910. *Beitrag zur Radioaktivität der Minerale (I. Mitteilung)*. *Wien. Ber.* 119: 181–190.

Sirk, Hugo. February 1913, 13 March 1913. Mitteilungen aus dem Institut für Radiumforschung (*Institute for Radium Research of the Austrian Academy of Sciences*). no 45 XXXVII. Ein Druckgefälle im Glimmstrom bei Einwirkung eines transversalen Magnetfeldes, *Wien. Ber. Abt. 2a*, 122: 417-476. Separate print of 59 pages and ten figures at three tables: Wien: Alfred Hölder. Abridged: 1913, *Anzeiger der Kaiserlichen Akademie der Wissenschaften*. 8: 96-97. Full Reprint: 1914. Ein Druckgefälle im Glimmstrom bei Einwirkung eines transversalen Magnetfeldes. *Ann. Phys.* series 2, volume 44 (of all volumes 349/ no. 11): 437-464.

Sirk, Hugo. 27 March 1934. Der Einfluss eines Magnetfeldes auf die Streuung von Röntgenstrahlen in Flüssigkeiten (*Einfluß eines magnetisches Feldes*). *Zeitschrift für Physik*. 89/3(-4): 129–142. Separate print: 1934. Berlin: J. Springer / Wien.

Sirk, Hugo. 1941. *Mathematik für Naturwissenschaftlern und Chemiker. Eine einföhrung in die Anwendungen der höheren Mathematik von Dr. Hugo Sirk*. Dresden/Leipzig: Theodor Steinkopff. Reprints: 1944. Dresden: Steinkopff; 1947. Dresden/Leipzig: T. Steinkopff; 1950. Dresden /Leipzig: T. Steinkopff (Reviewed by A. Chapanis: March 1951. *The Quarterly Review of Biology*. 26/1: 122); 1956. Berlin/Heidelberg: Springer; 1957. Dresden: Steinkopff. 12th edition: 1972. Darmstadt: Steinkopff. Translation from 3rd German edition by Tomás Batuecas: 1943. *Matemáticas superiores: aplicadas a la química y a la física*. Barcelona: Manuel Marín.

Sirk, Hugo. 1958. *Einföhrung in die Vektorrechnung für Naturwissenschaftler und Chemiker*. Darmstadt:

D. Steinkopff. 3rd Reprint modernized by Otto Rang: 1974. *Einföhrung in die Vektorrechnung fuer Naturwissenschaftler, Chemiker und Ingenieure*. Darmstadt: Steinkopf.

Sirk, Hugo; Danninger, Rudolf. 1950. Theorie einer magnetisch abgelenkten Glimmentladung auftretenden Druckfalles. *Wien. Ber. 2a* volume 159/3-6: pp. 59-62 (index of articles on page 329). Separate print: 1951. Vienna: Springer-Verlag 1950 (1951 edition (Ausgabe)).

Sitar, Sandi. 1985. *Letalstvo in slovinci. 1. Pionirsko obdobje in prava svetovna vojna*. Ljubljana: Borec.

Sitar, Sandi. 1987. *Sto slovenskih znanstvenikov, zdravnikov in tehnikov (A hundred Slovenian scientists, doctors, and technicians)*. Ljubljana: Prešernova Družba (Prešeren's Society).

Sitar, Sandi. 1989. Iz predzgodovine radijske in televizijske tehnike na Slovenskem (From the history of radio and television techniques in Slovenia). *Zbornik za zgodovino naravoslovja in tehnike (Anthology for the history of science and Technology)*, 10: 163-170.

Sitar, Sandi. 1993. *Jožef Stefan pesnik in fizik; ob stoletnici smrti*. Ljubljana: Park.

Sitar, Sandi. 1997. *Jurij Vega*. Bind to Čad, Gorazd. 1997. *Vegovo zasavje. 1797-1997: ob dvestoletnici logaritmov velikega slovenskega matematika*. Ljubljana: ZKO Moste-Polje/Dolsko: Turistično društvo.

Sitar, Sandi. 2010. Prvi slovenski balonar. *Prešernov koledar za leto 2010*. Ljubljana: Prešernova družba, 156–163.

Sittauer, Hans Leo. 1989. *James Watt*. Leipzig: Teubner.

Sivec, Ivan. 2016. *Kraljica s tremi kronami*. Mengeš: ICO.

Skubic, Anton. 1976. *Zgodovina Ribnice in Ribniške pokrajine*, Buenos Aires: Baraga S.R.L.

- Slaby, Adolf Carl Heinrich. 13 November 1906. Otto von Guericke. *Deutsches Museum Vorträge und Berichte Otto von Guericke*. München: Deutschen Museums. 3: 1-13.
- Smerdu, Franjo. 1964. Zdravstvo. *Slovenska Matica 1864-1964* (ed. Bernik, France). Ljubljana: Slovenska Matica. 380-388.
- Smith, Robert. 1738. *A compleat system of opticks in four books, viz. a popular, a mathematical, a mechanical, and a philosophical treatise. To which are added, remarks upon the whole. By Robert Smith LL. D. Professor of astronomy and experimental philosophy at Cambridge, and master of mechanicks to his Majesty. Vol. 2.* Cambridge: Cornelius Crownfield / London: Stephen Austen & Robert Dodsley. French translation by Pezenas: 1767. *Cours complet d'optique, traduit de l'anglais. Contenant la Theorie, la Pratique et les Usages de cette Science. En II toms.* I-IV. Avignon: Seguin & Aubert (NUK-8456 with G. Gruber's propriety entry: Zur Mechanic 1772).
- Smole, Majda. 1982. *Graščine na nekdanjem Kranjskem*. Ljubljana: DZS.
- Smolik, Marjan. 1980. Terpin (Trpin), Filip (keyword). *SBL*, p. 74.
- Smoluchowski, Marian von. 1911. Bemerkung zur Theorie des absoluten Manometers von Knudsen. *Ann. Phys.* 339/1: 182-184.
- Smullin, Louis Dijour. 1989. John George Trump (ed. National Academy of Engineering). *Memorial Tributes: National Academy of Engineering*, 3: 333-335.
- Soban, Darinka. 2004. *Johannes A. Scopoli - Carl Linneaus Dopisovanje/Correspondence 1760-1775*. Ljubljana: Prirodoslovno društvo Slovenije.
- Sodnik-Zupanec, Alma. 1943. *Vpliv Bošković's prirodne filozofije v naših domačih filozofskih tekstih XVIII stoletja*. Ljubljana: SAZU.
- Sodnik-Zupanec, Alma. 1975. *Izbrane razprave*. Ljubljana: Slovenska matica.
- Sokal, Alan D. 1996. Transgressing the Boundaries: Towards a Transformative Hermeneutics of Quantum Gravity. Final text in: *Social Text* (eds. Andrew Ross (& Bruce Robbins)) spring/summer 1996, 14/1-2 (nos. 46-47, 19960401): 217-252 published at anthology *Science Wars* (ed. Andrew Ross). Durham, N.C.: Duke University.
- Sokal, Alan D. May 1996/ June 5, 1996b. A Physicist Experiments With Cultural Studies. *Lingua Franca* (rd. Jeffrey Kittay at Yale University) Volume 7.
- Sokol, Velimir. 1981. *Stogodišnjica telefonije u Hrvatskoj*. Zagreb: Radna organizacija PTT prometa, PTT muzej.
- Sokolić, Davor. 1979. *Rečno brodarstvo*. Beograd: Tribina.
- Solovjev, Jury Ivanovič (Yuri Ivanovich Solovyov, Юрий Ива́нович Соловьёв, ed.). 1983. *Stanovlenie himii kak nauki (Khimii, Становление химии как науки)*. Moskva: Nauka.
- Sommervogel, Carlos, S.J. 1890-1900. *Bibliothèque de la Compagnie de Jésus, Première partie: Bibliographie par les Pères Augustin et Aloys de Backer, Nouvelle Édition par Carlos Sommervogel, S.J. Strasbourgeois, Tome I-IX*. Bruxelles/Paris: publiée par la Province de Belgique.
- Sorgeloos, Claude. 1982. La bibliotheque de Charles de Lorraine, *Revue belge de philologie et d'histoire* 60, no. 4, pp. 809-838.
- Sorgeloos, Claude. 1984. La bibliotheque du comte Charles de Cobenzl, ministre pleni-potentiaire dans Les Pays-Bas autrichiens et celle de son épouse, la comtesse Marie-Thérèse de Palffy. *Le livre & l'estampe* (Brussels) 30: pp. 115-210.
- Souciet, Étienne. 1726. *Commentaires chronologiques Recueil des dissertations du E. Souciet, contenant un abrégé de chronologies, cinq dissertations contre la chronologie de Newton, et une dissertation sur une médaille singulière d'Auguste*. Paris: Rollin.

Soulen, Robert John Junior. 1996. James Dewar, His Flask and Other Achievements. *Phys. Today*. 49/3: 32-37.

Sousedik, Stanislav. 1983. *Valerián (Valeriano) Magni (1586-1661)*. Prague: Typografie Clara Vyšehrad.

Sparnaay, Marcus Johannes. 1992. *Adventures in vacuum*. Amsterdam: North-Holland.

Sperlette, Johan. 1694. *Physica nova, sive philosophia naturae, ad usum academicae juventutis, secundum methodum hactenus in scholis receptam tradita ; in qua omnes naturae effectus, quantum fieri potest, mechanice, seu per inviolabiles motuum leges explicantur*. Berlin: J.M. Rüdiger, 1 Basilea (ST; NUK-8181).

Spiller, Robert. 1877. Über Beziehungen des Galvanismus zur teoretischen Chemie. VII. *Jahresbericht der k. k. (Kaiserlich-Königliche) Staats-Oberrealschule in Marburg Veröffentlicht von der Direction am Schlüsse des Studienjahres 1877*. 7: 3–28.

Spiller, Robert. 1884. Beitrag zur Kenntnis der Marburger Brunnenwässer. XIV. *programm Veröffentlicht von der Direction am Schlüsse des Studienjahres*. 14: 13-17.

Spiller, Robert. 1889. Beitrag zur Kenntnis der Marburger Brunnenwässer. XIX *programm Veröffentlicht von der Direction am Schlüsse des Studienjahres*. 19: 1–33. Reviewed and commented: *Z. öst. Gym.* 41: 1059.

Spitzer, Lyman. 1956. *Physics of fully ionized gases*. New York: Interscience publishers. Revised second edition: 1962. *Physics of fully ionized gases*. New York/London: Interscience publishers.

Spitzer, Lyman. 1997. *Dreams, Stars and Electrons*. Princeton University Press.

Spitzer, Sebastian. 2011. Jožef Stefan 1835-1893. Ein Mensch in der Lebensluft zweier Sprachen. *Festschrift 150 Jahre HTL1 (Höhere Technische Lehranstalt (Bundeslehranstalt) für Maschinenbau, Elektrotechnik und Mechatronik in Klagenfurt am*

Wörthersee, Higher Technical Institute, Lastenstrasse (HTBLA). 96-99.

Staebling, József Ferenz. 1772. *Dissertatio inauguralis chemico-medica sistens methodum generalem explorandi aquas medicatas quam... submittit in palatio universitatis Viennensis*. Posenii (Posen, Pošeň) as a city quarter of Bratislava (Pressburg): J.M. Landerer.

Stancovich, Pietro (Petar Stanković). 1829. *Biografia degli uomini distinti dell'Istria*. Trieste: Giovanni Marenigh.

Stark, Johannes. 1903. Der Kathodenfall des Glimmstromes im Magnetfeld. *Annalen der Physik*, 12/4: 31-51.

Stark, Johannes. 1907. Elementarquantum der Energie, Modell der negativen und der positiven Elektrizität. *Physikalische Zeitschrift*. 24 (8): 881-884.

Stark, Johannes; Walter Steubing. 1908. Ueber die spektrale Intensitätsverteilung der Kanalstrahlen in Wasserstoff. *Berlin.Ber.* Halbband 1 (1st Half-Volume), pp. 578-585.

Stark, Johannes; Walter Steubing. 1909. Spektralanalytische Beobachtungen an Kanalstrahlen mit Hilfe grosser Dispersion. *Annalen der Physik*, 4/28: 974-998.

Staroseljskaja-Nikitina, Olga Andreevna (Ol'ga Andreevna Starosel'skaja). 1967. *Ernest Rutherford*, Moscow: Nauka.

Stefan, Josef. 1864. Über eine Erscheinung am Newtonischen Farbengläse. *Wien. Ber.* II. 49: 135-137.

Stefan, Josef. 1864. Über die Dispersion des Lichtes durch Drehung der Polarisationssebene im Quarz, *Wien.Ber.* 50, II, no. 15, pp. 88–124. Abbreviated report with somewhat different title: Ein Versuch über die Natur des unpolarisirten Lichtes und die Doppelbrechung der Polarisationssebene im Quarz in den Richtung der optischen Axe. *Wien. Anzeiger* 1/23 (3 November 1864): 175-177. Abbreviated translation from *Wien.Ber.* provided by Wanklyn.

His translation was not published in *Intelligence and miscellaneous articles* but in main part of magazine under the title: On the Dispersion of Light by Quartz, owing to the rotation of the plane of polarisation. *Philosophical Magazine*, 4th series, 28th Volume, number 187 (August 1864) pp. 137-140.

Stefan, Josef. 1865. Über einige Thermoelemente von grosser elektromotorischer Kraft: (vorgelegt in der Sitzung am 23. März 1865); vorläufige Mittheilung. Wien. Ber. II (Sitzungsberichte der Mathematisch-Naturwissenschaftlichen Classe der Kaiserlichen Akademie der Wissenschaften: Abtheilung II/2) 51: 247, 260-262.

Stefan, Josef. 1871. *Über den Einfluß der Wärme auf die Brechung des Lichtes in festen Körpern*, Wien. Ber. II 63: 223–245.

Stefan, Josef. 1872. Untersuchungen über die Wärmeleitung in Gasen, Erster Abhandlung. *Wien. Ber. II* 65: 323-363.

Stefan, Josef (Jožef). 1879. Über die Beziehung zwischen der Wärmestrahlung und der Temperatur. *Wien. Ber. II*. 79: 391-428. Also, simultaneous separate publication: 1879. Wien, pp. 1-38.

Stefan, Josef. 1883. Vortrag über die Ziele der Techn. Wissenschaftlichen Commission. *Zeitschrift des Elektrotechnischen Vereines in Wien*. 1: 269.

Steska, Viktor. 1896. Kočevje. *Dom in Svet*. 9: 116-119, 182-184, 210-213, 243-245, 278-282.

Stewart, Balfour. 1866. *An Elementary Treatise on Heat*. Oxford: Clarendon Press.

Stefan, Karl. 1907. Geschichte der Entstehung und Verwaltung der k. k. Studien-Bibliothek in Laibach, *Mitteilungen des Musealvereines für Krain*, 20/1–3: 1–100.

Steinberg, Franz Anton. 1758. *Gründlichen Nachricht von dem in dem Inner-Crain gelegenen Cirknitzer See*. Ljubljana: Ana Elizabeta Reichardt. Reprint: 1861. Graz. Translation: *Le lac merveilleux ou description du lac de Cirknitz en Carniole, et des ses principales singularités Phisiques*. Tirés de

l'allemand de Steinberg. Brussels: King's imprimerie/Haag.

Steiner, Friedrich. 1892. Die Photogrammetrie, *Zeitschrift des österreichischen Ingenieur- und Architekten-Vereines*, 44/18: 287-289.

Steiner, Friedrich. 1893. Die Phographie. *Zeitschrift des österreichischen Ingenieur- und Architekten-Vereines*, 45/13: 199-201.

Steiner, Friedrich. 1894. Geschichtlichen... *Technische Blätter: Vierteljahrschrift des deutschen polytechnischen Vereines in Böhmen* (journal of German Polytechnic (*Technische Hochschule*) in Prague). 25: 225-232.

Steinwehr (Steinwähr), Wolf Balthasar Adolph von (translator). 1748-1759. *Der Königl. (Kays.) Akademie der Wissenschaften in Paris* (Académie royale des sciences de Paris) *physische Abhandlungen 2th, 6th and 8th parts (Theil)*. (J422); *Physische Abhandlungen Aus der Französischen Übersezt* (sic!), Wolf Balth Adolph v. Steinwehr 3th, 5th, 6th, 7th, 9th and 10th parts (Theil). Breslau: Johann Jakob Korn (J-614 where the third and fifth part had the same propriety entry "Coll. Lab. S.J. 1754" and the rest were without propriety entries. Noted by Wilde. Today we find a total of 1, 2, 3, 4. and 5th Part of *König. Akademie der Wissenschaften in Paris Physische Abhandlungen. Fünfter Theil welcher die Jahre 1716, 1717, 1718 in Sich hält. Aus der Franz. Übersetzt von Wolf Balth. Adolph von Steinwehr der König. Akademie der Wissenschaften and Berlin Mitglieder*. Breslau. Verlegst Johann Jakob Korn 1750« catalogued with a reference code NUK-8361; Erberg's books included those printed in 1748-1750).

Stejskal, Karl. 1891. *Repertorium über die ersten vierzig Jahrgänge und das Supplementheft des 37. Jahrganges der Zeitschrift für die österreichischen Gymnasien von 1850–1889*. Wien: Gerold.

Sternberg, Joachim. 1793. Aus einem Schreiben des Herrn Grafen Joachim von Sternberg, von Petersburg, den 26. März dieses Jahrs. *Sammlung Physikalisch Aufsätze, besonders die Böhmisches Naturgeschichte betreffend, von einer Gesellschaft*

- Böhmischen Naturforscher* (ed. Johan Mayer). Dresden: Walther, 3: pp. 402–408; 4: pp. 1–16.
- Steklasa, Ivan. 1881. Herbart X. Turjaški (Auersperg, 1613-1669). *Ljubljanski Zvon* (*Ljubljana Bell*, Ljubljana). 16: 612-616, 673-676, 739-741. Reprint: 1901. *Zbornik Slovenske Matice* (ZMS). 3: 90-119.
- Stiller, Wolfgang. 1989. *Ludwig Boltzmann*. Thun in Switzerland / Frankfurt am Main: Harri Deutsch.
- Stipišić, Jakov. 1972. *Pomoćne povijesne znanosti u teoriji in praksi*. Zagreb: Školska knjiga (School books).
- Stöger, Johann Nepomuk (Stoeger). 1855. *Scriptores Provinciae Austriacae Societatis Jesu*. Vienna: Typis Congregationis Mechitharisticae.
- Stokes, Sir George Gabriel. 1884-1887. *On light. In three courses delivered at Aberdeen in November, 1883, December, 1884, and November, 1885*. London / New York: Macmillan and Co. Authorised German translation of Otto Dziobek: 1888. *Das Licht: zwölf Vorlesungen gehalten in Aberdeen, 1883-1885, nebst zwei Vorlesungen über Absorption und Fluorescenz des Lichtes*, Leipzig: Johann Ambrosius Barth.
- Stoney, Georg Johnston. 1881. On the physical units of nature. *Phil. Mag.* 11: 381-390.
- Stoney, Georg Johnston. 1894. Of the 'Electron' or Atom of Electricity. *Phil. Mag.* 38: 418-420.
- Strkljević, Johan (Ivan). 1877. Nješto o uztrajnih momentih i razu. *Jahresberichte der k. k. Ober-Realschule zu Rakovac in der k. k. Kroatisch-Slavonischen Militär-Grenze*. 1876/1877, pp. 27-28, 69.
- Strnad, Janez. 1979. Ob sedemdesetletnici profesorja Antona Peterlina. *Proteus*. 41/8: 306-307.
- Strnad, Janez. 1985. Kako je Jožef Stefan odkril zakon o sevanju. *Zbornik za zgodovino naravoslovja in tehnike* (*Anthology for the history of science and Technology*), 8: 65–79.
- Strnad, Janez. 1995. *Fiziki*. Ljubljana: Modrijan.
- Strnad, Janez. 1996. *Razvoj fizike*. Ljubljana: DZS.
- Strojnik, Aleš. 1955. 50 kV elektronski mikroskop ljubljanske elektrotehniške fakultete (50 kV electron microscope at the Ljubljana Electrical Engineering Faculty). *Elektrotehniški vestnik*. 23: 213-217.
- Stroke, Hinko Henry (editor). 1994. *The Physical Review. The First Hundred Years*. New York, Maryland: American Institute of Physics Press.
- Strong, John (in collaboration with H. Victor Neher, Albert E. Whitford, C. Hawley Cartwright and Roger Hayward, illustrated by Roger Hayward). 1938. *Procedures in Experimental Physics* (*Fundamental operations in laboratory glass blowing - Laboratory optical work - Technique of high vacuum - Coating of surfaces: evaporation and sputtering - The use of fused Silica - Electrometers and electroscopes - Geiger counters - Vacuum thermopiles and the measurement of radiant energy - Optics: light sources, filters, and optical instruments - Photoelectric cells and amplifiers - Photography in the laboratory - Heat and high temperature - Notes on the materials of research - Notes on the construction and design of instruments and apparatus - Molding and casting*), New York/Englewood Cliffs, NJ: Prentice-Hall, Inc.
- Studen, Andrej. 2010. Maribor na poti v moderno mesto. *Mesto in gospodarstvo: mariborsko gospodarstvo v 20. Stoletju* (ed. Oset, Željko; Berberih Slana, Aleksandra; Lazarević, Žarko). Ljubljana: Inštitut za novejšo zgodovino / Maribor: Muzej narodne osvoboditve. 35–56.
- Stulli, Luca. 1823. Lettres du Dr. L. Stulli, *Sur les détonations de l'île de Meleda*. Raguse, 1823, In octavo, 111–118.
- Stulli, Luca. 1823. *Sulle Detonazioni della Isola di Meleda. Lettere*. Ragusa: Martechini. 54 pages (NUK-18860).
- Stulli, Luca. 1824. *Pel Giorno Natalizio di Sua Maestà Francesco I. di Austria ... Versi* (in Latin and Italian languages by Antonio Chersa, Luca Stulli, and others), Ragusa: Martechini. in 8°.

Stulli, Luca. April 1826. Sulle Detonazioni di Meleda, lettera del Dottore Stulli (Ragusa) al Urbano Lampredi in 1826). *Antologia di Firenze (Antologia: giornale di scienze, lettere, ed arti)*. Firenze: al Gabinetto scientifico e letterario di Gian Pietro Vieusseux direttore e editore. volume 22 /no. 64: 95-103, 160.

Stulli, Luca. January 1827. Intorno alle cose di Meleda Lettera del dott. Stulli, Ragusa 23 settembre 1826.. *Antologia di Firenze (Antologia: giornale di scienze, lettere, ed arti)*, volume 25/ No. 73: 190-192.

Stulli, Luca. 1828. *Sulle Detonazioni dell'Isole di Meleda*. Bologna: Ric. Masi.

Stulli, Luca. 1825. Notice sur un phénomène observé dans l'île de Meleda, Letter sent on June 4, 1825. *Bibliothèque Universelle des sciences, belles-lettres, et arts. Sciences et arts*. Geneve & Paris. Volume 10 / tome 29: pp. 267-270.

Sturm, Johann Christoph. 1676. *Collegium Experimentale, sive curiosum, in quo primaria hujus seculi inventa & experimenta physico-mathematica, speciatim campanae urinatoriae, camerae obscurae, tubi Torricelliani, seu baroscopii, antliae pneumaticae, thermometrorum, hygroscoptorum, telescopiorum, microscopiorum &c. phaenomena & effecta, partim ab aliis jam pridem exhibita, partim noviter istis superaddita, per ultimum quadrimestre anni M. DC. LXXII. viginti naturae scrutatoribus, ex parte illustri nobilique prosapia oriundis, & spectanda oculis subjecit, et ad causas suas naturales demonstrativa methodo reduxit, quodque nunc accessione multa, demonstrationum ac hypothesium veritatem porró illustrante, confirmante, & à nonnullorum cavillationibus vindicante, locupletatum amicorum quorundam suasu & consilio publicum adspicere voluit Johannes Christophorus Sturmius*. Nuremberg: Wolfgang Moritz Endter & heirs of Johann Andreas Endter. Reprints: 1678, 1685. *Collegium experimentale*. Vol 1-2, Nuremberg: Endter (Volume 2 in NUK-GS 8341 bind to Robert Boyle's. 1682. *Experimentorum novorum physico-mechanicum continuatio secunda*. Genevae, bind to Sturm's. 1685. *Epistola* bind to JJ Becher's, 1680. *De nova*

temporis dimetiendi ratione bind to Johann Daniel Majori's. 1679. *Consideratio ferri Radiantis qua in Naturam Ignei Aut Lucidi Spiritus utcunq[ue] inquiritur: & incidenter quaedam De Thermis, Novo Artificio Parandis, adduntur*, bind to Giovanni Alfonso Borelli's. 1669. *Historia et Meteorologia*, bind to Honoré Fabri's under pseudonym Petro Mosnerio (Mousner). 1646. *Tractatus physicus de motu locali, in quo effectus omnes, qui ad impetum, motum naturalem, violentum, & mixtum pertinent explicantur, et ex principiis physicis demonstrantur*).

Sturm, Johann Christoph. 1697. *Physica electiva sive hypothetica*, vol 1, Nuremberg: Endter (NUK-GS 8477), Continuation by volume 2: 1698. Altdorf: Kohles,.

Subotowicz, Mieczyslaw. 1959. Najwcześniejsza drukiem wydana rozprawa o eksperymentalnym dowodzie istnienia próżni. *Kwartalnik historii nauki i techniki*. (Warszaw). 4/1: 35-76.

Suess, Eduard. 1893. Josef Stefan. Bericht der Gesammt-Akademie und der mat-nat. Klasse (Classe), *Almanach der kaiserlichen Akademie der Wissenschaften* (Wien). 43: 252-257.

Suhadolc, Anton. 2000. On the beginnings of physics lessons at the University of Ljubljana (O začetkih pouka fizike na ljubljanski univerzi). *Obzornik za matematiko in fiziko*. 47/5: 182-184.

Suhadolc, Anton. 2000. Dr. Valentin Kušar, the first physics teacher in the University of Ljubljana (Dr. Valentin Kušar, prvi slovenski predavatelj fizike na univerzi v Ljubljano). *Obzornik za matematiko in fiziko*. 47/6: 147-149.

Sumitomo, Kichizaemon (in Ōsaka Furitsu Tioshokan (大阪府立図書館, Osaka)). 1957. *A classified catalogue of old books on science and technology published during the period from the end of 16th century to the middle of the 19th century: selections from the Sumitomo collection of the Osaka Prefectural Library. (Donated by Baron Kichizaemon Sumitomo)*. Osaka: Prefectural Library. Revised reprint: 1963-1964. *A classified catalogue of the books on science and technology; Sumitomo collection of the Osaka Prefectural Library, donated by Kichizaemon*. 1-2. Osaka: Prefecture Library.

Sumitomo (Sumitomo Masatomo). 1979. *From the History of Sumitomo: more than three centuries of development guided by the "founder's precepts."*. Tokyo: Sumitomo Shoji (Shōji) Kaisha, Ltd.

Sunzel (Sunczel), Fridericus; Argyropoulos, Joannes. 11 May 1499. *Collecta et exercitata Friderici Sunczel Mosellani liberaliu[m] studioru[m] magistri in octo libros Phisicor[um] Arestotelis in almo studio Ingolstadiensi (Ingolstadiensi)*, Hagenaw (Augsburg): Heinrich Gran, Johannes Rynman (NUK-R 488; FSLJ; TE, 1655, 15^v). Reprint: 1506. Venetiis: Jacobus Pentius (NUK-18112=ST-21/83 98^f in 21/83 110^f, NUK-R 20834, T).

Sušnik, Ivan. 6 March 1896. Novi Svetlobni Trakovi. Znašel prof. W. K. Röntgen v Würzburgu (New light strips. Discovered by W.K. Roentgen in Würzburg). *Slovenec: političen list za slovenski narod* (Ljubljana: Katoliška Tiskarna) 24/55: pages 1-2 of four unnumbered pages of that journal.

Sutherland, William. 1896, 1897. Thermal transpiration and radiometer motion. *Phil. Mag.* (5) 42: 373-391, 476-492; 43: 83.

Svoboda, Venczel (Swoboda, Wenzel). 31 July 1855. Über (Ueber) die Konstruktion der Materie nach der atomistischen Ansicht. *Fünftes Programm des k.k. Katholischen Gymnasiums zu Preßburg am Schlusse des Schuljahres*. 3-14. Continued in the same yearly by: Tuschar, Gregor, 1855. Aphoristisches für Philologen über das Unterrichtsverhältniss der Muttersprache zu jenem in den classischen. *Fünftes Programm des k.k. Katholischen Gymnasiums zu Preßburg am Schlusse des Schuljahres*. 15-23.

Svoljšak, Sonja, 2006. Naključja po Koperniku: Kopernikovo delo De revolutionibus orbium coelestium libri VI v knjižnici Frančiškanskega samostana v Ljubljani: novo odkritje. *Delo (Ljubljana)*, 2nd December 2006, No. 279, p. 19.

Svoljšak, Sonja; Vidmar, Luka. 2019. *Baron Sigismund Zois's library (Knjižnica barona Žige*

Zoisa: središče razsvetljenske kulture na Slovenskem). Ljubljana: NUK.

Swedenborg, Emanuel. 1721. *Nova Observata et inventa circa ferrum et ignem. Et præcipue circa naturam ignis elementarem, unà cum nova camini invention (New discoveries observed about the iron and fire. More especially, the nature of the fire element, along with the discovery of a new stove)*. Amsterdam: Joann Oosterwyk. Changed reprint in 2nd edition: 1722. *Eman. Swedenborgii ... Miscellanea observata circa res naturales & præsertim circa mineralia, ignem & montium strata. Pars Prima, Secunda, tertia (Eman. Swedenborg ... Various observations in nature, especially regarding the minerals, fire and stratum in mountains. First, second and third part)*. Leipzig: unknown publisher.

Swedenborg, Emanuel. 1734. *Principia rerum naturalium sive novorum tentaminum phaenomena mundi elementaris philosophice explicandi*. Dresdae & Lipsiae: Frideric Hekeli (NUK-8914).

Swift, John. 1950. *Adventure in vision. The First Twenty-Five Years of Television*. London: John Lehmann.

Szily, Kálmán von Nagy Szigeth (Coloman Nagyszigeth, Nagy-Szigeth). 1871. *A Hamilton-féle elv és a mechanikai hő-elmélet második főtétele [Collig. 10.] (Hamilton's principle and the second law of mechanical heat theory)*. Pest: Eggenberger (published in 1872 on eight pages), Translations: 1872. VIII. Das Hamilton'sche Princip und der zweite Hauptsatz der mechanischen Wärmetheorie. *Annalen der Physik und Chemie*, 221/2 (1872): 295-302; 1872. XLII. On Hamilton's principle and the second proposition of the mechanical theory of heat. *The London, Edinburgh, and Dublin Philosophical Magazine and Journal of Science*, 43/287 (187205): 339-343.

Szily, Kálmán von Nagy Szigeth (Coloman Nagyszigeth, Nagy-Szigeth). 1873. Das dynamische Princip von Hamilton in der Thermodynamik. *Annalen der Physik und Chemie*, 225/5: 74-86. Translation: 1873. "LV. On Hamilton's dynamic principle in thermodynamics. *The London, Edinburgh, and Dublin Philosophical Magazine and Journal of Science*, 46/308 (187312): 426-434.

Szily, Kálmán von Nagy Szigeth (Coloman Nagyszigeth, Nagy-Szigeth). 1875. *A hő-elmélet második főtétele, levezetve az elsőből (The second main theorem of heat theory, derived from the first, presented on the meeting of Hungarian Academy of Sciences on 15 May 1875)*. Budapest M. Tud. Akadémia Könyvkiadó Hivatala, 15 pages. Translations: 1875. Das Zweite Hauptsatz der mechanischen Warmtheorie abgeleitet aus dem ersten, *Annalen der Physik und Chemie, Ergänzungsband (Supplementary volume) 7* (1876): 154-167; 1876. IV. The second proposition of the mechanical theory of heat deduced from the first. *The London, Edinburgh, and Dublin Philosophical Magazine and Journal of Science*, 1/1 (187601): 22-31; 1876. *Kosmos. Les mondes; revue hebdomadaire des sciences et leurs applications aux arts et à l'industrie, par. M. l'Abbé (François-Napoléon-Marie) Moigno* (Paris: editor J. Rothschild).

Szily, Kálmán von Nagy Szigeth (Coloman Nagyszigeth, Nagy-Szigeth). 1876. XXXIII. On the dynamical signification of the quantities occurring in the mechanical theory of heat. *The London, Edinburgh, and Dublin Philosophical Magazine and Journal of Science*, 2/11 (187610): 254-268. Translation: 1877. *Ann.Phys.* 160 (2): 435-449; 1877. *Carl's Rep.* 13: 97-113.

Šamperl Purg, Kristina. 2001. Oris nacionalne podobe tehniške inteligence v avstroogrski monarhiji ob prelomu stoletja na primeru Janeza Puha. *Melikov zbornik (Melik's anthology)*. (ed. Vincenc Rajšp, Rajko Bratož, Janez Cvirn, Jasna Fischer, Walter Lukan, Branko Marušič). Ljubljana: ZRC SAZU, 655-666.

Šantel, Anton. 1874. Poskus razkladbe nekaterih pomenljivih prikazni spanja in sanj (An Attempt at an Explanation of Some Meaningful Dreams). *Jahresbericht des k.k. Staatsgymnasiums in Görz: veröffentlicht am Schlusse des Schuljahres 1874*, pp. 42-57.

Šantel, Anton. 1883. Physikalische Kleinigkeiten. I. Ein leicht herstellbarer Apparat zur Luftverdünnung mittelst Quecksilbers. Pp. 27-36. II. Eine Überraschende Art elektrischer Abstoßung von Flüssigkeiten. Pp. 37-40. III. Apparat für unmittelbare Umsetzung der Sonnenwärmen

mechanische Arbeit. Pp. 40-43. IV. Eine neue Art elektrischer Schallübertragung. Pp. 43-49. *Dreiunddreissigster Jahres-bericht des k. k. Staats-Gymnasiums in Görz*. Görz (Gorizia). Pp. 27-49. The first part of the discussion, number I, entitled Ein leicht herstellbarer Apparat zur Luftverdünnung mittelst Quecksilbers (pp. 27-36) was according to Vilko Novak's keyword in *SBL* reprinted as: Kahlbaum-Šantelsche Luftpumpe. *Pfaundler's Compendium of Experimentalphysik*. In fact, it was noted as *Sprengels pumpe mit selbsttätigen Quecksilberanhebung. System Schantel-Kahlbaum* of Georg Wilhelm August Kahlbaum in Leopold von Pfaundler's reprint. 1906. *Müller-Pouillet's Lehrbuch der Physik und Meteorologie*. 10th edition, Braunschweig: Friedrich Vieweg, pp. 498-499.

Šantel, Anton. 2006. *Zgodbe moje pokrajine*. Ljubljana: Nova revija.

Šešić, Marija. 1996. Martin Sekulić, prvi Teslin profesor fizike (Мартин Секулић). *Phlogiston*. no. 4: 54-82.

Šetina, Janez. 1993. Vakuumski Merilniki. *Vakuumska tehnika za srednješolske predavatelje* (ed. Jenko, Bojan; Breclj, Franb). Ljubljana: Društvo za vakuumsko tehniko Slovenije. Page 64.

Škafar, Vinko. 1993. Books in former Capuchin monastery library of Maribor (Knjige v knjižnici v nekdanjem kapucinskem samostanu v Mariboru (1613-1784)). *Časopis za zgodovino in narodopisje*. 64/1: 62-92.

Škofljanec, Jože. 2008. *Observanti province sv. Križa in slovenske pokrajine od konca 15. do srede 18. stoletja*. PhD thesis. Ljubljana: Philosophical Faculty.

Šlebinger, Janko. 1933. Matek, Blaž (1852-1910) (Keyword). *Slovenski biografski leksikon: Keywords Maas - Mrkun*. (ed. Franc Ksaver Lukman et all). Ljubljana: Zadružna gospodarska banka, 2/5: 321.

Šmitek, Zmago. 1997. Antropološka misel koprškega polihistorja. *Acta Histriae* (Koper), 5: 25-40.

- Šorn, Jože. 1984. *Začetki industrije na Slovenskem*. Maribor: Založba Obzorja.
- Štih, Peter. 1996. Celjski grofje, vprašanje njihove deželno knežje oblasti in dežele celjske. In: *Grafenauerjev Zbornik* (ed. Rajšp, Vincenc). Ljubljana: ZRC SAZU, 227-256.
- Štuhec, Marko. 1995. *Rdeča postelja, ščurki in solze vdove Prešeren*. Ljubljana: ŠKUC.
- Štuhec, Marko. 2005. O kranjskem plemstvu. *Almanach in slikarstvo druge polovice 17. stoletja na Kranjskem* (Edited by: Barbara Murovec; Matej Klemenčič; Mateja Breščak). Ljubljana: ZRC SAZU, 97-121.
- Šubic, Ivan. 1897. *Elektrika, nje proizvodnja in uporaba (Electricity, its production and use)*. Ljubljana: Matica Slovenska.
- Šubic, Ivan. 1902. Dr. Josip Stefan. *Zbornik znanstvenih in poučnih spisov* (Ljubljana: Slovenska Matica), 4: 62–85.
- Šubic, Ivan. 1903. Prof. dr. Simon Šubic, *Ljubljanski Zvon*, 23/12: 744-748.
- Šubic, Simon. 1860. Physikalische Abhandlung über die Zusammensetzung fortschreitender und drehender Bewegungen und ihre Anwendung zur Erklärung der Aberration des Lichtes, des Foucault'schen Pendelversuches, des Erscheinung des Freischwebens der rotirenden Scheibe an Fessel's Rotationsmaschine und am Kriesel. *Jahres-Bericht der Ober-Realschule zu Pest*. 1–56
- Šubic, Simon. 1861. *Lehrbuch der Physik für Ober-Gymnasium und Ober-Realschulen*. Pesth: Gustav Heckenast; 2nd edition: 1867. Pest; 3rd edition: 1874. Buda-Pest.
- Šubic, Simon. 1862. Der Hebel und die Kräftepaare nebst ihrer Anwendung in der Mechanik, *Erster Jahres-Bericht der Wiener Kommunal-Realschule in der Vorstadt Rossau*, 3–44.
- Šubic, Simon. 1862. *Grundzüge einer Molekular-Physik und einer mechanischen Theorie der Elektrizität und des Magnetismus*. Wien: Braumuller.
- Šubic, Simon. 1862. Review: K. Robida, Erklärung der Lichterscheinungen. *Z. öst. Gym.* 13: 320–322.
- Šubic, Simon. 1864. Review: Th. Gerding, Schule der Physik für Lehranstalten und zum Privatgebrauch. *Z. öst. Gym.* 15: 526–529.
- Šubic, Simon. 1864. Über den Begriff der Temperatur, *Dritte Jahres-Bericht der Wiener Kommunal-Realschule in der Vorstadt Rossau*, 1-40.
- Šubic, Simon. 1871. *Lehrbuch der Physik für Unter-Realschulen*. Pest: Gustav Heckenast.
- Šubic, Simon. 1872. Mehanična teorija o toploti, 1st part, *Rad.* 19: 12–61.
- Šubic, Simon. 1874. Dinamična teorija o plinih, *Rad.* 29: 1–144.
- Šubic, Simon. 1875. Telegrafija, zgodovina njena in današnji stan (Telegraphy, its History and Modern State). *Letopis slovenske matice*. Separate pagination at the end of anthology, 1–57.
- Šubic, Simon. 1876. Manometer – Hygrometer. *Wien.Ber. mat.-nat. Kl. II* 73: 531-552. Simultaneous separate special edition on 22 pages, Wien: Gerold's Sohn. Printed after Jelinek's positive expert opinion signed on 19 April 1876 kept at ÖAWB 314 ex 1876. The extended Croatian translation of the discussion including Dalton's hygrometric research was adopted at JAZU in Zagreb on 19 October 1876 and published as 1877. New methods for determining moisture in the air (Nove metode za opredeljevanje vlage v zraku). *Rad.* 40: 1-18.
- Šubic, Simon. 1882. O imenitnejših električnih iznajdbah (About the more significant electrical inventions). *Kres (Kres, Literary and scientific Journal)*. Klagenfurt. 2: 479-485, 533-538, 585-590.
- Šubic, Simon. 1896. Photography of invisible things (Fotografovanje nevidnih stvari). *Home and World (Dom in svet)*. 9: 155-159, 186-189.

Šubic, Simon. 1896. Človeško telo – prozorno (The human body – transparent). *Home and World (Dom in svet)*. 9: 412-414.

Šubic, Simon. 1898. Žive fotografije (Live photos). *Home and World (Dom in svet)*. 11/1: 18-20.

Šubic, Simon. 1898. Röntgenova luč in človeško telo (Röntgen's light and the human body). *Home and World (Dom in svet)*. 11: 218-221.

Šubic, Simon. 1901. Na skrajnih mejah vročine in mraza (At the extreme limits of heat and cold). *Home and World (Dom in svet)*. 14/8: 495-500, 14/9: 559-562, 14/10: 627-634.

Šumrada, Janez. 1992. Valvasorjev angleški sodobnik Edward Browne v slovenskih deželah leta 1669 (Valvasor's English Contemporary Edward Browne in Slovenian Areas). In: *Valvasorjev zbornik (Valvasor: ob 300 letnici izida Slave vojvodine Kranjske: referati s simpozija v Ljubljani 1989)*. pp. 54-102.

Šumrada, Janez. 2001. Žiga Zois in Déodat de Dolomieu. *Kronika*. 49/1-2: 65-72.

Šumrada, Janez. 2007. Poglavitne poteze napoleonske politike v Ilirskih provincah. *Zgodovinski časopis*. 61/1-2: 75-84.

Tapolcsányi, Laurentius (Lörlinc, Lörinc, Vavrinc Tapolčáni, Topolčanský); his student Ladislav Korlatkőy (Ladislao Korlatkoy de Labs). 1706. *Academicus ens naturale per questiones philosophicas compendiose controvertens in alma Archiepiscopali Universitate Tyrnoviensi Societatis Jesu a Perillustri Domino Ladislao Korlatkoy (Korlatkőy) de Labs tt. II. Philosophiae Baccalaureo formato, ejus demque pro Suprema Laurea Candidato approbato Disputatus; Praeside Reverendo Patre Laurentio Tapolcsani (Tapolcsáni) e Societate jesu tt. II. Philosophiae Doctore, ejusdemque Professore Ordinario*. Additionally, in the same year: *Axiomata Christiano - politica discursibus ethicis é Senecae Cordubensis philosophi operibus collectis, illustrata. Et honori perillustri domini Ladislai Korlatkőy de Labs&c. AA. LL. & Philosophiae Baccalaurei formati. Sem. S. Adalb. Convict. dum in Alma Archi-Episcopali Universitate Tyrnaviensi Societatis Jesu, supremâ*

AA. LL. & Philosophiae Laureâ condecoraretur promotore R. P. Laurentio Tapolcsani é Societate Jesu, AA. LL. & Philosophiae Doctore, ejusdemq, Professore ordinario, ac p. t. Seniore, dicata. Ab Addictissimis Philosophiae Neo-Magistris. Tyrnaviae [Trnava]: Typis Academicis (FSLJ-7 e 57 propriety entry: Sigmund Skerpin (Škerpin) lectoris philosophis). Revised reprint. 1726. *Academicus, ens naturale, per quaestiones philosophicas controvertens, nuper thesibus ex universa philosophia in ... Universitate Tyrnaviensi Societatis Jesu a ... Ladislao Korlatkőy de Labs, ... praeside Laurentio Tapolcsáni ... disputatis, praefixus, nunc ab authore revisus et auctus*. (participating: Joseph Calasancius Reviczky; Ferenc Vigyázó). Tyrnaviae [Trnava]: Typis Academicis per Fridericum Gall.

Tarasov, Boris Nikolaevič (Тарасов, Борис Николаевич). 1979. *Pascal*. Moskva: Molodaja gvardii.

Tarasov, Lev Vasil'evich (Тарасов, Лев Васильевич, Тарасов). 1985. *Lazery: dejstvitel'nost' i nadeždy (Лазеры: действительность и надежды)*. Moscow: Nauka.

Targosz, Karolina. 1971. Le mécénat de Louise-Marie de Gonzague et les liens scientifiques Franco-Polonais au XVII^e siècle. *XII^e Congrès international d'Histoire des sciences*. XI: 137-142.

Tartareti, Peter (Tatareti, Tartaret); Peter Hispanus (supposedly Pope John XXI); additional notes about six Aristotelian book of the editor master Martin Molenfelt from Livonia by Baltic. 1514. *Expositio magistri Petri Tatareti in summulas (Summulae) Petri Hispani, una cum passibus Scoti undequoque in marginibus sparsis: maturiori q. hucusque diligentia summoque studio recognita: a pluribus mendis, que in prioribus habentur libris emmendata: summaque accuratione Basileae impressa. Additus est tractatus indissolubilium ejusdem et obligatorum magistri Martini Molenfelt ex Luconia*. Basileae (Basel): Joan. Troben. Bind to: 1) 1514. *Magistri Petri Tatareti commentarii in Isagogas Porphyrii et libros logicorum Aristotelis*, Basel; 2) 1514. *Commentarii (Commentaria) Petri Tatareti in libros philosophie naturalis et metaphysice Aristotelis*. Basel; 3) 1514. *Petri Tatareti in sex libros Ethicorum questiones adjecto textu Aristotelis*.

Based: Johann Froben de Hammelburg (ST, today NUK-GS 5070).

Tartareti, Peter (Tatareti, Pierre Tataret). 1581. *Scotistae Subtilissimi in universam Philosophiam. Venetiis: Apud Hæredes Melchioris Sessæ. Reprint: 1592. Petri Tatareti Parisiensis Ioan. Duns Scoti doctoris subtilis sectatoris fidelissimi in Aristotelis philosophiam naturalem, diuinam & moralem exactissima commentaria: quibus passim inservuntur questiones quamplurimæ. Venetiis: hæredes Melchioris Sessæ (first part is Peter Hispanus' *Summulae*, FSNM). Reprint: 1621. Petri Tatareti parisiensis, Scotistæ subtilissimi in vniversam philosophiam opera omnia, in tres partes distribvta: in qvarvm prima, svmmvlæ Petri Hispani commentarijs & expositionib acutissimia exacte pertractantur ... triplici indice ... & rerum memoria dignarum loclupetissimo adornarum. Venetiis: Jacob Sarzin (FSLJ-19 g 13).*

Tartarotti, Girolamo. 1749. *Del congresso notturno delle Lammie libri tre / di Girolamo Tartarotti Roveretano ; s'aggiungono due dissertazioni epistolari sopra l'arte magica. All' ... Ottolino Ottolini. Rovereto: Giambatisto Pasquali (coat of arms as propriety entry of Josephus Gabriel de Buset (Jožef Gabriel Buset) now NUK-GS I 25500). Including: Dissertazione epistolare sopra la magia e segheria (20 December 1745) pp. 317–350, next Tartarotti's answer up to p. 447. Copied in: Gian Rinaldo Carli's letter dated 13 June 1782 sent to Paduan professor of astronomy Giuseppe Toaldo; Reprinted in: 1785. *Delle opere del signor commendatore Don Gianrinaldo, conte Carli. Milano: Imperial monistero di S. Ambrogio maggiore, vol. 9, pp. 61–177, followed by: Ragionamenta sulla teoria del sig. Cavalilere Rosa, pp. 179f.**

Tartini, Giuseppe. 1977. *Scienza Platonica fondata nel Cerchio. Padova: Cedam-Casa Editrice Dott. Antonio Milani.*

Taton, René. 1976. La formation de Sadi Carnot: École Polytechnique et École de Metz., *Sadi Carnot et l'essor de la Thermodynamique. Ecole polytechnique, 11-13 juin 1974, table ronde du C.N.R.S., Paris Paris: Editions CNRS (Éditions du centre de la recherche scientifique). 35-56.*

Taufferer, Inocenc. 1760. *Dissertatio Cl. Mairani De Causa Variationum Barometri. Bind to: Tentamen Publicum ex Universa Philosophia, Quod In Archiducali, & Academico Soc. JESU Collegio Labaci ex praelectionibus r. p. Innocentii Taufferer Soc. Jesu of philosophy Professor Publ. & Ord. Subiverunt Perillust. D. Aloysius Vermati, de Vermesfeld, Carn. Lab. Nobilis D. Antonius Feichtinger, Carn. Locopolitanus. Prolusionis loco Explanabuntur Phaenomena motus Astrorum Systemtis Copernicani. Ljubljana: Typis Joannis Georgii Heptner, Inclytae Provinciae Carnioliae Typographi.*

Taussig, Eduard. 28 June 1890. Electric Furnaces. *Scientific American*, 29/756 (supplement 18900628): 12077.

Tavagnutti, Maurizio. 2002. Giovanni Fortunato Bianchini and the first studies on the subterranean river Timavo in the ancient county of Gorizia, 6th *International Symposium on History of Speleology and Karstology in Alps, Carpathians, and Dinarids, ALCADI, Gorizia, 23 May 2000-28 May 2000. Proceedings* (ed. Tavagnutti, Maurizio). Gorizia.

Tavzes, Janko. 1929. *Slovenski preporod pod Francozi (Slovenian renaissance Under Frenchmen). Doktorska disertacija (PhD dissertation) na Filozofski fakulteti, Ljubljana: Filozofska Fakulteta.*

Temple, Robert Kyle Grenville. 1991. *The genius of China: 3,000 years of science, discovery, and invention. Introduction by Joseph Needham. London: Prion.*

Themistius; Aristotle; Nogarola, Lodovico; Barbaro, Ermolao; Zimara, Marco Antonio. 1554. *Themistii ... Paraphrasis in Aristotelis. Posteriora, & Physica. In libro item De anima, Memoria et reminiscencia, Somno et vigilia, Insomniis, & Diuinatione per somnum, Hermolao Barbaro ... interprete. Additae sunt et lucubrationes, quae Themistii obscuriora loca apertissima reddunt: Additus & index, necnon contradictionum solutiones Marci Antonii Zimarrae in dictis eiusdem Themistii: omnia à studioso quodam & vtriusque linguae peritissimo, summa fide recognita, & quibus scatebat erroribus repurgata: His demum omnibus adiecimus eiusdem Themistij*

paraphrasem in librum tertium De anima nuper a ... Ludouico Nogarola Veronensi, latinatae donatam, ac suis subtilissimis scholiis illustratam. Venezia: Girolamo Scoto (FSLJ-19 a 14).

Templer, Richard H.; Attard, George S. 4 April 1991. The Fourth State of Matter. *New Scientist*. 130/1767: 25-29.

Tenne, Reshef, Margulis, Lev; Genut, Menachem; Hodes, Garry. 1992. Polyhedral and Cylindrical Structures of WS_2 . *Nature*. 360: 444.

Teraš, Mavricij. 1929. *Iz zgodovine, življenja in delovanja kapucinov: v spomin 400-letnice Kapucinskega (Capuchin) reda.* Celje: Kapucinski samostan.

Tesla, Nikola. lectured in 1875 (1876), published in 1884. O kapilarnim cevima. *Srbadija: Almanah Srp. akad. liter. Društva »Srbadije« u Gracu. Uređuje ured. odbor.* Novi Sad: A. Pajević. pp. 1–236, Tesla's work on p. 1.

Tesla, Nikola. lectured on May 12/20, 1891. Experiments with Alternate Currents of Very High Frequency and Their Application to Methods of Artificial Illumination. *American Society of Electrical Engineers* in New York Columbia University. Noted among others at: January 1891 (sic!). *Transactions of the American Institute of Electrical Engineers (IEEE)* 8/1: 266-319; 11 June 1891. *Electrical World*. pp. 18-19; July 24, 1891 & July 31, 1891 & August 7, 1891. (*The telegraphic Journal and*) *Electrical review*. London. pp. 103-108, 147-151, 176-179. Republished: 1956. *Nikola Tesla: lectures, patents, articles* (Documents taken from the Nikola Tesla Museum, Beograd. Selected and prepared with plates, including portraits by the eds. Popović, Vojin; Horvat, Radoslav; Nikolić, Nikola). Beograd: Nikola Tesla Museum, L-15-17; 1973. *Nikola Tesla: lectures, patents, articles*. Mokelumne Hill, California: Health Research.

Tesla, Nikola. 1 July 1891. Electric Discharge in Vacuum Tubes. *The Electrical Engineer (New York)*. A-16.

Tesla, Nikola. 26 August 1891. Reply to J.J. Thomson's Note in the *Electrician* of July 24, 1891. *The Electrical Engineer (New York)*.

Tesla, Nikola. April 4, 1897. *Lecture before New York academy of science: The Streams of Lenard and Roentgen and Novel Apparatus for Production* 6 April 1897. Reprint: Leland I. Andreson (ed.) 1992. *Lecture before New York academy of science: The Streams of Lenard and Roentgen and Novel Apparatus for Production: reconstructed* 6 April 1897. Breckenridge (Colorado): Twenty First Century Books.

Tesla, Nikola. May 5, 1897. On the Hurtful Actions of Lenard and Roentgen Tubes, *Electrical Review* (N. Y.).

Tesla, Nikola. August 11, 1897, August 19, 1897. On the Source of Roentgen Rays and the Practical Construction and Safe Operation of Lenard Tubes, *Electrical Review* (New York).

Tesla, Nikola. June 1900. The problem of increasing human energy, with the special reference to the harnessing of the sun's energy. *The Century Illustrated Monthly Magazine*. 175-211. Translation of Alessandra Goti: 2014. *Sull'incremento dell'energia umana: con un riferimento particolare all'energia solare e altri scritti*. Prato: Piano B. Translated and commented by Pandur, Tibor Hrs. In Collaborations with his reviewers Detela, Andrej; Južnič, Stanislav; Mertik, Matej. 2019. *Problem povečevanja človeške energije s posebnim ozirom na pridobivanje energije sonca*. Ljubljana: Založba ZRC / Maribor: Litera / Ljubljana: Abo grafika.

Tesla, Nikola. 10 July 1937. Prepared Statement by Nikola Tesla (For interview with the press on 81st birthday observance). Retrieved on May 22, 2020 from: <http://teslaresearch.jimdo.com/articles-interviews/prepared-statement-by-nikola-tesla-july-10-1937/>

Tesla, Nikola. 1919. *My Inventions: the Autobiography of Nikola Tesla*. New York: Cosimo Classics. Translations: 1981. *Moji pronalasci = My inventions*. Zagreb: Školska knjiga. With prologue by Tomo Bosanac; 2013. *Nikola Tesla. Moji izumi*. Ljubljana: Sanje. With prologue by Andrej Detela.

Tesla, Nikola. 1999. *Colorado Springs Notes 1899-1900* (ed. Aleksandar Marinčić and Vojin Popović). Beograd: Zavod za učbenike i nastavna sredstva.

Těšínská, Emilie. 1 January 2010. *Ernst Mach, his Prague physics students and their careers. Ernst Mach – Fyzika – Filosofie – Vzdělávání* (ed. Dub, Petr; Musilová, Jana) 1. vyd. (1st edition), Brno: Masaryk's University (Masarykova univerzita), pp. 75–117.
www.muni.cz/press/books/files/mach75.pdf,
retrieved 23 January 2013

Thewes, Alfons. 1983. *Oculus enoch... Ein Beitrag zur Entdeckungsgeschichte des Fernrohrs*. Oldenburg: Isensee.

Thillaye, Nicolas. 1766. *Manuel Nécessaire à ceux qui achètent la Machine Pneumatique, de la construction du sieur Nicolas Thillaye, Pompier privilégié du Roi, demeurant à Rouen; Contenant 1°. Des instructions pour démonter, remonter & entretenir en bon état lesdites machines. 2°. L'usage de cette pompe pneumatique, ou un recueil d'expériences choisies qu'on peut faire avec cet instrument, & à la suite de ce recueil, la description de la marmite de Papin simplifiée par le même auteur, la manière d'en faire usage; & en outre celle d'une nouvelle casserole, ainsi que d'une cafetière, l'une & l'autre portant son bain-marie, & le certificat d'approbation de MM. de l'Académie des sciences de Paris*, Rouen: Étienne-Vincent Machuel, rue S. Lo, vis-à-vis le Palais.

Thomson, George Paget. 1967. *J. J. Thomson and the Cavendish Laboratory in his day*. London and Edinburgh: Nelson.

Thomson, George Paget. 1961. *The inspiration of science*. London/Oxford: Oxford University Press. Reprint: 1968. New York: Anchor. Translation of Vitalii Nikolaevich Lystsov (Виталий Николаевич Лыццов): 1970. *Duh Nauki (Spirit of Science)*. Moscow: Nauka (Knowledge, Science).

Thomson, Joseph John. 1891. *Electrician (London)*. Reprint: 10 June 1891. Some Experiments on the Electric Discharge in Vacuum Tubes. *The Electrical*

Engineer (New York). Tesla responded on 1 July 1891. *The Electrical Engineer (New York)*.

Thomson, Joseph John. 24 July 1891. Note by Prof. J.J. Thomson. *Electrician (London)*. Reprint: 12 August 1891. *The Electrical Engineer (New York)*.

Thomson, Joseph John. 1907. *The Corpuscular Theory of Matter*. London: Archibald Constable.

Thomson, Joseph John. 1936. *Recollections and Reflections*. London: G. Bell / Cambridge: University Press.

Thomson, Joseph John. 1964. Joseph John Thomson, *The Origins and Growth of Physical Science*, volume 2, part V The breakdown of classical physics (ed. Hurd, David Leonard; Kipling, John Jervis). Baltimore: Penguin Books. 2: 340-362.

Thorndike, Lynn. 1923. *History of Magic and Experimental Science: during the first thirteen centuries of our era. Volume 2 (Twelfth and thirteenth centuries)*. New York: Columbia University Press.

Thorndike, Lynn. 1941-1958. *History of Magic and Experimental Science*. Volumes 5-8. New York: Columbia University Press.

Tišler, Miha. 2003. *Prispevki kemije k evropski kulturi in civilizaciji*. Ljubljana: SAZU.

Titelmann, Franz (Titelman, Francisco). 1535. *Compendium naturalis philosophiae libri duodecim de consyderatione rerum naturalium: earumque ad suum creatorem reduction*. Antuerpiae: Simon Cocus. Reprints: 1564. *Compendium Philosophiae naturalis. Seu: De Consideratione rerum naturalium earumque ad suum Creatorem reductione Libri XII. Authore Francisco Titelmano Hassellensi ordinis fratrum minorum, sanctarum scripturarum apud Louanienses Praelectore...* Lugduni Batavorum: Guliel. Rouillius (W-1569; NUK-4571). 1582. *Compendium philosophiae naturalis, seu de Consideratione rerum naturalium earumque ad suum creatorem reductione libri XII, authore Francisco Titelmano, Hassellensi*. Paris: Hier. de Marnef / T. Belot (FSLJ).

- Tocchini, Gerardo. 2004. La religione degli Antichi nell'Italia dei Lumi. Gianrinaldo Carli nella cultura europea del suo tempo (ed. Trampus, Antonio). *Quaderni Giuliani di Storia* (Trieste). Anno XXV: 37-96.
- Toepler, August (Töpler). 1865. Ueber die Erzeugung einer eigenthümlichen Art von intensiven elektrischen Strömen mittelst eines Influenz – Elektromotors. *Ann.Phys.* (5/5) 125 (201/7): 469-497.
- Toepler, August (Töpler). 1866. Vergleichende Versuche über die Leistungen der Influenz-Maschine mit und ohne Metall-Belegung. *Ann.Phys.* (5/7) 127: 177-199.
- Toepler, August. 1875. Experimental-Vorlesung über die Erscheinungen der Capillarität. *Mittheilungen des naturwissenschaftlichen Vereines für Steiermark*. 10 April 1875: XLIX–LI.
- Tomić, Aleksandar S. 2005. Ruđer Bošković i čestično-talasni dualizam. *Zbornik radova konferencije »Razvoj astronomije kod Srba III« Beograd 25th–28th April 2004 (Proceedings of a conference “Developments of Astronomy among the Serbs”, ed. Dimitrijević, Milan Sergijević) Beograd: Astronomsko društvo “Ruđer Bošković”, 263-271.*
- Tomić, Jakov Jasha (Tomich, Томић, Јаков „Јаша”) editorial unsigned article. 1911. About G. Kraškovič. *Zastava* (Novi Sad) radical party's local newspaper (Застава, Нови Сад). 2 November 1911.
- Tonks, Lewi, Langmuir, Irving. 1929. Oscillations in Ionized Gases. *Phys. Rev.* 33/2: 195-210 (dated 20 November 1928, published 1 February 1929). Continuations under the same title: 1929. Note on “Oscillations in Ionized Gases”. *Phys. Rev.* 33/6: 990-990 (Published 1 June 1929).
- Tonks, Lewi, Langmuir, Irving. 15 September 1929. A general theory of the plasma of an arc. *Phys. Rev.* 34/6: 876-922.
- Torbar, Josip. 1871. Sjeverna zora. *Rad.* 17: 90–111.
- Torbar, Josip. 1873. Izvještaj sa Svećane sjednice (Report from a gala session of JAZU), *Rad.* 25: 252.
- Torrini, Maurizio. 1979. *Dopo Galileo una polemica scientifica (1684-1711)*. Firenze: Accademia Toscana di scienze e lettere »La colombaria«, »studi« LIV & Leo S. Olschki.
- Toynbee, Arnold. 1962-1964. *A Study of History*. New York/London: Oxford University Press, Volumes 1-12. Reprint: 1972. London: Oxford University Press in association with Thames & Hudson.
- Toynbee, Arnold. 1976. *Mankind and Mother Earth: A Narrative History of the World*. London: Oxford University Press.
- Trampus, Antonio. 1997. »Dottrina magica« e »scienza cabalistica« nei rapporti fra Tartarotti, Gianrinaldo Carli e Scipione Maffei. *Atti della accademia roveretana degli Agiati* (Rovereto: L'Accademia), Serie 7 vol. 6a: 137-152.
- Trampus, Antonio. 2004. Tra assolutismo e lumi: l'antico Regime e il regno delle discontinuità. Gianrinaldo Carli nella cultura europea del suo tempo (ed. Trampus, Antonio). *Quaderni Giuliani di Storia* (Trieste). Anno XXV: 217-238.
- Trampus, Antonio. 2006. Gianrinaldo Carli at the centre of the Milanese Enlightenment. *History of European Ideas* (Oxford: Pergamon Press), vol. 32: 456–476.
- Trane, Francesca. 1993. *La Biblioteca dei Cappucini di Ruffano, profilo storico e catalogo*. Lecce: Congedo.
- Trbižan, Milan. 2003. Objava J.V. Valvasorja v glasilu Philosophical (!) Transactions in the year 1687 o litju kipov s tanko steno – prvi slovenski tehnični dokument. *Livarski vestnik*. 50/4: 175-184.
- Trdina, Janez. 1903. *Bahovi huzarji in Iliri, spomini iz moje profesorske službe na Hrvaškem (1853-1867) (Memories from my teaching jobs in Croatia)*. Ljubljana: L. Schwentner.
- Tremblay, Jean-François. 19 July 1999. The Skinny on Flat-Screen Displays. *Chemical & Engineering News*. 77/29: 19-28.

Tremel, Ferdinand. 1946. Schiffhart und Flösserei auf der Mur. *Jahresbericht des Akademischen Gymnasiums in Graz* (Graz), 3–41.

Tricarico, Franc (promotor). 1755. *Physicae recentioris Origo antiqua, per dialogos epistolares demonstrata. Authore R.P. Regnault è Societate Jesu ex Gallico Recens Latine Reddita. Auditoribus oblata a perillustri, ac perdocto D. Georgio de Zobel, Austriaco Viennensi, Philosophiae in secundum annum Auditore, Caesarei Ferdinandeï Convictore Graecii*. Graz: Haeredum Widmanstadii. Bind to: *Dum assertiones ex Philosophia universe ex praelectione admodum Reverendi P. Francisci Tricarico è Societate Jesu, Philos. Profess. Publ. Ordin. Et Examineris, admodum Reverendi Joseph Mayer è Societate Jesu, Ethices et J. N. Professor Publ. Ord. Et Examinatoris; admodum reverendi P. Joan. Bapt. Kaschutnig è Societate Jesu, Matheseos Professor Publ. Ord. in alma ac celeberrima Universitate Graecensi publice propugnaret, anno M.DCC.LV, mense Augusto, die 24* (the professors Karl Dollenz or Josef Kössler were not involved as Dollenz dies earlier and Kössler taught in Vienna during Graz studies of the Viennese Georgius de Zobel), Graz: Haeredum Widmanstadii (Widmanstetter).

du Trieu (Trieu), Philippe. 1600. *Manuductio ad logicam... conscripta a R.P. Philippo Du Trieu è Societate Jesu...* Munich: Johann Jaeckel. Reprints: 1614. *Manuductio ad Logicam: sive Dialectica studiosae juventuti ad Logicam praeparandae conscripta*, Duaci (Douai): Balthasar Beller; 1623. *Manuductio ad logicam: siue dialectica studiosae juventuti ad logicam praeparandae*. Ingolstadt: Wilhelm Eder (FSLJ-20 f 87); 1635. Coloniae Ubiorum (Köln): Johannes Kinckius (195 pages, 15 cm (octavo)); 1657. Coloniae (Köln); Johannes Kinckius (Auersperg's book; Tübingen UB; Münster ULB; Jena ULB; Augsburg UB); 1670. *Manuductio ad logicam sive dialectica studiosae juventuti ad logicam praeparandae conscripta a Philippo Du Trieu e societate Jesu*. Leodis: J.K. Hovius. Bind to 1670-1675. *Definitiones, Divisiones, Ac Regulae Ex Logica & Physica Aristotelis Appendicis loco ad dialecticam R. P. Philippi Du Trieu Soc. Jesu editae*. Leodis: Hovius (FSLJ-10 e 61 with propriety entry of Sigismund Anton Joseph Ursini Count of Blagaj in 1716 before the Franciscans acquired that book);

1711. *Manuductio ad logicam: sive Dialectica studiosae juventuti ad logicam praeparandae: appendicis loco nunc in fine accesserunt Definitiones, divisiones ac regula ex logica et physica Aristotelis / Conscripta A R. P. Philippo du Trieu, è Societate Jesu, in Collegio Aquicinctino Duaci philosophiae professore primario*. Coloniae Agrippinae: Friessemiana Joan. Everhardi Fromart (MINSPT).

Trigg, George Lockwood. 1975. *Landmark Experiments in Twentieth Century Physics*, New York: Crane & Russak / London: E. Arnold. Reprint: 2018. New York: Dover. Russian translation: 1978. *Fizika [dvadcatogo] veka ključevye eksperimenty*. Moscow: Mir.

Trigler, Johann Georg von Iglaraw. 1614. *Sphaera, das ist: Ein kurtzes Astronomisches Tractätlein von der Sphaera und des Himmels Lauff: dem ewigen Schöpffer des Himmels und der Erden/ und alles was darinnen ist/ zu Lob/ Ehr/ Preisz und Danck: der lieben Deutschen Nation zu Ruhm und Ehren/ und dann allen Liebhabern der Mathematischen Künsten zu lieb/ nutz und frommen in die Deutsche Sprache gebracht und verfertigt*. Leipzig: Gross; reprints: 1622. Leipzig; 1678. *Sphaera: das ist Ein kurtzes astronomisches Tractätlein (Tractat), in welchem nicht allein von d. Himmelslauff, der Sternen Kraft, sondern auch, wie man Nativiteten rechnen...: Darinnen über zweyhundert Curiöse Fragen sambt dero selben Erörterung, von der Sphaera und des Himmels Lauff sol, gehandelt wird. Dem Ewigen Schöpffer ... zu Lob ... in die deutsche Sprache gebracht und mit 23. Figuren verfertigt Durch ... Joh. Georg Trieglern v. Iglaraw*. Franckfurt am Mäyn (Leipzig): G. von R. in Henning Grosse's office (FSLJ-16 g 40); 1705. *Astronomische Curiositäten, Darinnen etliche Hundert Nützliche Fragen Sambt dero selben Erörterung Von der Sphaera und des Himmels Lauff, Sonn und Mond, Sternen, Cometen, Finsternissen, Donner, Hagelwetter, Wasser-fluthen, Erdbeben, Hitze, Kälte und Winden zu befinden: Allen Liebhabern der Mathematischen Künste, so wohl hohen als niedern Standes-Personen, insonderheit denen Hauß-Vätern in Städten und auf den Lande zu Beobachtung dero Haußhaltung, höchst-nützlich und nöthig = Himmel Lauf*. Frankfurt: Henning Gross.

- Troha, Zdravko. 2003. *Kočevski Nemci – partizani*. Ljubljana: Slovensko Kočevarsko društvo Peter Kozler.
- Truesdell, Clifford Ambrose. 1980. *The tragicomical history of thermodynamics 1822-54*. New York: Springer.
- Trump, John George; Van de Graaff, Robert Jemison; Cloud, Robert W. 1940. Cathode rays for radiation therapy. *Am J Roentgenol Radium Ther Nucl Med (The American Journal of Roentgenology Radium Therapy and Nuclear Medicine)* 43: 728-734.
- Trump, John George; Van de Graaff, Robert Jemison; Cloud, Robert W. 1940. Compact, supervoltage, roentgen - ray generator using a pressure-insulated electrostatic high voltage source. *Am. J. Roentgenol.* 44: 610-614.
- Trump, John George; Cloud, Robert W. 1940. Physical characteristics of supervoltage roentgen rays. *Am. J. Roentgenol.* 44: 615.
- Tuschar, Gregor, 1855. Aphoristisches für Philologen über das Unterrichtsverhältniss der Muttersprache zu jenem in den classischen. *Fünftes Programm des k.k. Katholischen Gymnasiums zu Preßburg am Schlusse des Schuljahres*. 15-23.
- Tschermak, Gustav Edler von Seysenegg. 1860. Einige Sätze der theoretischen Chemie. *Wien. Ber.* 41: 67-112. Read on May 18, 1860. Also separately printed in Vienna by Karl Gerold on 48 pages including title page.
- Tschermak, Gustav Edler von Seysenegg. 1861. Die spezifische Wärme bei constantem Volumen. *Wien. Ber.* 43: 394-396. Read on April 18, 1861. Also separately printed in Vienna by Karl Gerold on 3 pages.
- Tschermak, Gustav Edler von Seysenegg. 1862. Die Dichte im Verhältnisse zur Form und chemischen Beschaffenheit der Krystalle. *Wien. Ber.* 45: 603-626. Read on April 3, 1862. Also separately printed in Vienna by Karl Gerold on 3 pages.
- Tschermak, Gustav Edler von Seysenegg. 1863. *Grundriss der Mineralogie*. Wien: W. Braumüller.
- Tušek, Ivan. 1869. *Fizika*, Translation of Schoedler's *Physik (Physics)* by Ivan Tušek, professor at Zagreb. Ljubljana: SM.
- Tyndall, John. November 1864. XXXIX. On luminous and obscure radiation caloriscence, *The London, Edinburgh, and Dublin Philosophical Magazine and Journal of Science*, 28/190 (186411): 329-341.
- Tyndall, John. March 1865. XXXII. On the history of calorescence. *The London, Edinburgh, and Dublin Philosophical Magazine and Journal of Science*, 29/195 (186503): 218-231.
- Tyndall, John. 1863. 1865. *Heat considered as a mode of motion, Being a Course of Twelve Lectures Delivered at the Royal Institution of Great Britain in the Season of (January 23-April 10) 1862*. London: Longman, Roberts, & Green. Translations: 1874. *A Hő mint a mozgás egyik neme. Irta J. Tyndall, fordít. Jezsovics Károly... ; előszót ... írt hozzá Szily Kálmán (Heat as a sort of movement. Written by J. Tyndall, translated by Károly Jezsovics; preface added by Kálmán von Nagy Szigeth Szily)*. Budapest: Természettudományi Társulat; 1894. *Die Wärme betrachtet als eine Art von Bewegung von John Tyndall; autorisierte deutsche Ausg. [aus dem Englischen übers. und] bearb. von Anna von Helmholtz und Clara (Louise) Wiedemann nach der 8. Aufl. des Originals*. Braunschweig: Vieweg.
- Tyndall, John. 1894. *Das Licht. sechs Vorlesungen. autorisierte deutsche Ausg. bearb. von Clara (Louise) Wiedemann. mit einem Vorwort von G. Wiedemann. mit einem portrait von Thomas Young*. Braunschweig: F. Vieweg.
- Ubel, Stella (ed.). 1955. *A. Dürer, katalog drvoreza i bakroreza iz Valvasorove zbirke*. Zagreb: JAZU.
- Udagawa, Shinsai (宇田川榛齋). 1834/1835. *Ensei Ihō Meibutsu Kō Hoi (遠西医方名物考補遺, Addition to the medicinal and other useful case and thoughts)*. Osaka: Kawachiya Tasuke & Kawachiya Gisuke/Edo: Suharaya Ihachi.

Umek, Ema. 1986. Navigation by Sava in 18th century (Plovba po Savi v 18. stoletju). *Historical Review (Zgodovinski časopis)*. 40/3: 233-268.

Umek, Ema. 2006. Kranjska kmetijska družba: 1767-1787. *Arhivi (Archives)*. 29/1: 1-34.

Urbanitzky, Alfred knight. 1885. Das elektrische Licht. In: *Bericht über die internationale elektrische Ausstellung Wien 1883, unter Mitwirkung hervorragender Fachmänner herausgegeben vom niederösterreichischen Gewerbe-Vereine*, Wien: L.W. Seidel und Sohn, Redacteur. Dipl. Ing. Franz Klein (ed. Franz Klein). 385-470.

Urbanitzky, Alfred knight. 1887. *Elektricität und Magnetismus im Alterthume*. Wien: A. Hartleben.

Urbanitzky, Alfred knight. 1895. *Die Elektrizität im Dienste der Menschheit: eine Darstellung der magnetischen und elektrischen Naturkräfte und ihrer praktischen Anwendungen: nach dem gegenwärtigen Standpunkte der Wissenschaft*, Wien: A. Hartleben.

Urbanitzky, Alfred knight. 1895. *The cyclopædia of electrical engineering : containing a history of the discovery and application of electricity with its practice and achievements from the earliest period to the present time : the whole being a practical guide to artisans, engineers and students interested in the practice and development of electricity, electric lighting, motors, thermo-piles, the telegraph, the telephone, magnets and every other branch of electrical application*. Philadelphia: Gebbie Pub. Co.

Urbas, Anton. 1876. *Magnetismus, Elektrizität, Wärme und Licht (Magnetizem, elektrika, toplota in svetloba. Filozofično-fizikalichen načert, Magnetism, electricity, heat and light. Philosophical-physical description)*. Laibach/Ljubljana: self-publishing (Selbstverlage, samozaložba) printed by J. Blasnikovi dediči (Blasnik's heirs).

Uršič, Milena. 1965. Anton Rožič, o kulturnem razvoju na Kranjskem do leta 1823 = Antoine Rožič, l'histoire culturelle de la Carniole jusqu'à l. 1823. *Razprave. [Razred 2], Slovenska akademija znanosti in umetnosti, Razred za filološke in literarne vede = Dissertations. Classis 2, Philologia et litterae*, Ljubljana: SAZU, 6: 69-140.

Uršič, Milena. 1975. *Jožef Kalasanc Erberg in njegov poskus osnutka za literarno zgodovino Kranjske*. Ljubljana: SAZU.

Ustinov, Nikolai Dmitriyovich (Nikolaï Dmitrievich); Borisov, Vasilij Petrovič. 1989. Vidajuščisja izobretatel i učeenii V. K. Zworykin (K 100-letiju so dnja roždenija) (Видаючица изобретатель и учение В. К. Зворыкин (К 100-летию со дня рождения), Leading inventor and scientist V.K. Zvorykin (On the occasion of the 100th anniversary of his birth). *VIET*. No. 4: 121-124.

Valenčič, Vlado. Waldreich zu Ehrenporten, Caharija (1623–1682) (keyword), *SBL*. 4/14: 661.

Valenčič, Vlado; Faninger, Ernest; Gspan-Prašelj, Nada. 1991. Zois Žiga (Sigismund) von Edelstein (keyword). *SBL*. 4/15: 832-846.

Valvasor, Janez Vajkard (Magić, Vladimir; Kukolja, Božena (ed.); Gostiša, Lojze; Šikić, Žana; Gaberščik, Boris. 1995. *Bibliotheca Valvasoriana, katalog knjižnice Janeza Vajkarda Valvasorja (catalogue of library of Janez Vajkard Valvasor)*. Ljubljana: SAZU / Zagreb: Nacionalna i sveučilišna library.

Valvasor, Janez Vajkard. January-February 1687. Part of a Letter written in Latin to Thomas Gale, S.T.D. Secret. Reg. Soc. from Carniola, By Mr. John Weichard Valvasor Liber Baro; Containing *the Method of casting Statues in Metal; together with an Invention of his for making such cast Statues of an extraordinary thinness, beyond any thing hitherto known or practised*, *Phil. Trans.* 16/186: 259-262 copperplate 1 on N. 186. Latin original: 1692. Pars epistolae ad Thomam Gale, S.T.D. Secret. Reg. Soc. e Carniolia perscriptae a Dn. Joh. Weichardo Valvasor, Lib, Barone: qua continetur Methodus statuas ex metallo fundendi: una cum ejusdem invento, pro istiusmodi Statuis extraordinaria tenuitate conflandis, ultra quam hactenus cognitum aut in praxi visum suit, *Actorum Eruditorum quae Lipsiae publicantur supplementa*. Leipzig (Lipsiae): Joh. Grossii haeredes & J.F. Gleditschium, Supplement 1: 315-319 and figure 3 of table V (quoting no. 318 of *Phil. Trans.* 1687).

Valvasor, Janez Vajkard. 1689. *Die Ehre deß Hertzogthums Crain*. Laybach-Nürnberg: Wolfgang Moritz Endter. Reprint: 1971. München: Trofenik. 1-4. Partly translated: 1977. *Slava Vojvodine Kranjske*. Ljubljana: Mladinska Knjiga (Juvenile books).

Van Doren, Carl Clinton (ed); Franklin, Benjamin. 1945. *Benjamin Franklin's Autobiographical writings: Selected and edited by Carl van Doren*. New York: Viking press printed by the Haddon. Reprint: 1952. *Benjamin Franklin's Autobiographical writings*. New York: Viking Press.

Vanino, Miroslav. 1987. *Isusovci i hrvatski narod, II* Zagreb: Filozofsko-teološki institut družbe Isusove.

Varen, Bernhard. 1650. *Bernhardi Vareni med. d. Geographia generalis, in qua affectiones generales telluris explicantur, summa cura quam plurimis in locis emendata, & XXXIII schematibus novis, 5re incisus, una cum tabb. aliquot quae desiderabantur aucta & illustrata*. Amsterlodami: Elsevier (J-628 now NUK-21466, with Jesuistical propriety entry: "A reu. (=reverendum) patre Papler Societ. Jesu, rectore Fluminensi dono dat[us] die 10 Augusti 1668:"). Reprint: 1771. *Geographia generalis, in qua affectiones generales telluris explicantur*. Amstelodami: ex Officina Elzeviriana (Loci Capucinatorum Crainburgi now KSSKL). Newton's edition: 1672. *Geographia generalis... Ab Isaaco Newton of mathematics Professor Luciano*. Cantabrigiae: Joann Hayes, Henric Dickinson. Reprints of Newton's edition: 1681... *Editio secunda auctior et emendatior*. Cambridgae; 4th edition: 1693. *Berhardi Vareni Geographia generalis, in qua affectiones generales telluris explicantur / summâ curâ quam plurimis in locis emendata, & XXXIII. schematibus novis, aeri incisus una cum tabb. aliquot quae desiderabantur aucta & illustrata ab Isaaco Newton...; juxta exemplar Cantabrigiae. Editio 4. auctior [et] emendatior cum indice capitum et propositionum*. Jena: Heinrich Christoph Croker (NUK-2451 with propriety entry: "Ex libris Josephi Kraus cathalogo Labacensi inscriptus 1718" and on title page: "Catalogo Societatis Jesu ... Labaci inscriptus 1726:"); 1712. Cambridge: Cornelii Crownfield; Russian Translation of Polikarpov-Orlov, Feodor (Поликарпов-Орлов, Феодор Поликарпович): 1718. *Geografia generalnaja (География*

генеральная Б. Варениуса), nebesnii i zemnovodnii krugu kipni s ih svoijstva i doeistva v trah knjigah oposujocajaja, prevedena s latinska jazika na rossijskij i napечatana v Moskvje povelienem Tsrkago Presvietla Velichestva lieta Gdnia 1718 v iunie. Moscow (NUK-DS 48066).

Varignon, Pierre. 1690. *Nouvelles conjectures sur la pesanteur*. Paris: Jean Boudot.

Vater, Christian. 1734. *Physica experimentalis systematica in usum studiosae iuventutis*, Witebergae (J-21 as W-1465 now NUK-8306 with a bookplate: "Ex. Liberales artes P. Ignat. Redlhamer Inscriptus Bibl. Phil. Coll. Labac S.J. 1755").

Vavilov, Sergej Ivanovič (Wawilow); Levšin, Vadim Leonidovič (Lewschin, W. L.). 1926, 1927. Die Beziehungen zwischen Fluoreszenz und Phosphoreszenz in festen und flüssigen Medien, *Zeitschrift für Physik* 35/11-12 (192611): 920-936; *Zeitschrift für Physik A Hadrons and Nuclei*, 44/6-7 (19270601): 539-539.

Vdovičenko, Natalja Vasiljevna (Вдовиченко, Vdovichenko, Vdovychenko, Vdovychenko). 1985. Rol mehaniki v formirovanii termodinamiki. *Issledovanija po istorii fiziki i mehaniki*. Moskva: Nauka. 254-280.

Vega, Garcilaso de la (El Inka, Ynca). 1608-1609. *Comentarios reales: que tratan del orige[n] de los yncas, reyes que fueron del Perú, de su idolatria, leyes y gobierno en paz y en guerra de sus vidas y conquistas y de todo lo que fué aquel imperio y su republica, antes que los españoles passaran a el* (*Comentarios reales de los Incas*). Lisboa (Lisbon): Pedro Crasbeeck. Translation: 2009. *Kraljevski zapiski o Inkah*. Ljubljana: Sanje.

Vega, Jurij. 1788. Observationes eclipsis Solis Die 15 Junius 1787... Observatio eiusdem eclipseos in observatorio C. R. á Perillustri D Georgio Vega Centurione, & Professore Matheseos in Academia Militari Rei tormentariae. *Ephemerides Astronomicae Anni 1788* (ed. Hell, Maximilian). Vienna: Trattner.

- Vega, Jurij. 1800. *Vorlesungen über die Mathematik, IV Bd. (=fourth part) Anleitung zur Hydrodynamik*. Wien: Trattner.
- Vega, Jurij. 1784. *Vorlesungen über die Mathematik. Zweyter Band, welcher die theoretische Geometrie, die ebene und sphärische Trigonometrie, die Anfangsgründe der praktischen Geometrie, eine Abhandlung von den krummen Linien, und die Differenzial- und Integralrechnung enthält*. Wien: Johann Thomas Edlen von Trattnern. 507 pages (NUK-4083/2). 2nd edition: 1803. *Vorlesungen über die Mathematik sowohl überhaupt zu mehrerer Verbreitung mathematischer Kenntnisse in der k. k. Staaten, als auch ins besondere zum Gebrauche des k. k. Artillerie=Corps. Zweyter Band, die theoretische und practische Geometrie, die geradlinige und sphärische Trigonometrie, die höhere Geometrie, und die Infinitesimal=Rechnung enthaltend. Zweite, verbesserte und vermehrte Auflage*. Wien: Johann Thomas Edlen von Trattnern. 663 pages, 16 Copperplates. 8th edition: 1848.
- Vedaldi Iasbez, Vanna. 2004. Gianrinaldo Carli fra erudizione e storia: le Antichità Italiane". Gianrinaldo Carli nella cultura europea del suo tempo (ed. Trampus, Antonio). *Quaderni Giuliani di Storia*, Trieste: Deputazione di Storia Patria per la Venezia Giulia, Anno XXV/1: 217-238.
- Verhulst, Sabine. June 2005. "L'insegnator di scienze" dans le 'Trattato dello stile e del dialogo' de Sforza Pallavicino. *Archives internationales d'histoire des sciences / Division d'Histoire des Sciences de l'Union Internationale d'Histoire et de Philosophie des Sciences, Académie Internationale d'Histoire des Sciences* (ed. Sergescu, Pierre et all). 55/154: pp. 115-126.
- Verhaeren, Hubert. 1949. *Catalogue de la Bibliothèque du Pe-t'ang*. Pekin: Impr. Des Lazaristes; Reprint: 1969. Paris: Société d'Édition Les Belles Lettres.
- Vidmar, Milan. 1937. *Med Evropo in Ameriko*. Ljubljana: Naša Založba.
- Vidmar, Milan (unsigned report related to his speech at Academic Club of Electro technicians in Ljubljana on 11 February 1937). 1937. Obisk pri Nikoli Tesli, *Slovenski dom* (ed. Jože Košiček, issued-published by Ivan Rakovec, printed by Jugoslovanska tiskarna in Ljubljana represented by K. Čeč). 11 February 1937, 2/33: 3.
- Vidmar, Milan. 1953. Nikola Tesla, *Slovenski Poročevalec* 14 January 1953, volume 14, no. 11, p. 5.
- Vidmar, Milan. 1964. *Spomini (Memories)*. Maribor: Obzorja.
- Vidmar, Tadej. 2000. »Obena deshela, ne meistu ne gmaina, ne mogo pres shul« – Usoda protestantskih deželnih šol v Ljubljani, Celovcu in Gradcu. *Šolska kronika*. 9(33)/1: 9-27.
- Viegas, Arthur. 1921. Ribeiro Sanchez e os Jesuitas Amigo ou inimigo? *Revista de historia. Lisboa Empresa Literaria Fluminense*. 10A/10: 256-264.
- Villermont, Charles (Villermont, count Charles Marie Joseph Hennequin). 1925. *Le comte de Cobenzl, ministre plénipotentiaire aux Pays-Bas*. Lille: Desclée.
- Villoslada, Riccardo García. 1954. *Storia del Collegio Romano dal suo inizio (1551) alla soppressione della Compagnia di Gesù (1773)*. Rome: Aedes Universitatis Gregorianae.
- Vincentius, Ioannes (Vincent, Jean). 1677. *Discussio peripatetica in qua philosophiae Cartesianae principia, per singula fere capita, seu articulos dilucidé examinantur. Auctore R.P.I. Vincentio*. Toulouse: ex officina Colomeriana, & Posueliana, sub signo Palladij Tolosani, 522 pages.
- Vjalcev, Anatolij Nikolaevič (Вяльцев, Анатолий Николаевич). 1981. *Discoveries of elementary particles (Otkrytie èlementarnych častic elektron [Beta], foton [Gamma], Otkrytie èlementarnych častic: электрон (Бета), фотон (Гамма))*. Moscow: Nauka.
- Vlacovich, Nicolò (Vlahović, Nikola). 1862a. Sulla scarica instatanea della bottiglia di Leyda. *Il Nuovo Cimento* (Bologna), 16/8: 30–73. Reprint: 1862b. *Wien.Ber.* 46: 531-572 (10 July 1862).

Vlacovich, Nicolò (Vlahović, Nikola). 1863. Sulla durata della scintilla elettrica. *Programma dell' i. r. Ginnasio di Capodistria (Reports of Grammar school (Gymnasium) Koper, Izvestja Gimnazije Koper)*. 3-11; Simultaneous print: 1863. *Il Nuovo Cimento*. 17: 356–367.

Vlacovich, Nicolò. 1864. Importanza delle scientifiche speculazioni per il progresso dell'industria. Discorso, *Program of Real school Trieste (Programma della Civica scuola reale superiore in Trieste, Trieste: LLOYD adriatico)*, 3-15.

Vlacovich, Nicolò. 1866. Sulle forze motrici ed id particolare sugli elettromotori e sui motori a gaz, *Reports of Real school Trieste (Programma della Civica Scuola Reale Superiore di Trieste)* 3-37 and one table on additional p. 39. Separate print: Trieste: Coen.

Vlacovich, Nicolò. 1867. *Rapporti sull'Esposizione Universale di Parigi del 1867 dei tre inviati dall'inclito consiglio della città di Trieste*. Trieste: pubblicati per cura della Società triestina per le arti e le industrie [reports of (rapporti di) Nicolò Vlacovich, Giorgio Nicolich, Giuseppe Bruni]. Reprint: 1868. Rapporto sull'esposizione internazionale in Parigi nel 1867 con i speciale riguardo a Trieste ed alle provincie limitrofe. With 20 illustrations (Con 20 figure intercalate nel testo). *L'Amico dell'Artiere, Giornale dell' associazione Triestina per le arti e l'industria* (ed. Cameroni, Francesco). Trieste: Hermanstorfer. Aso separate print (opuscolo separato): 1 868.

Vlacovich, Nicolò. 1868. On 16 September 1868 the Veronese chemist Teodoro Triulzi as the secretary on second meeting of third extraordinary session (Seconda Seduta of Terza riunione straordinaria) of *Società Italiana di scienze naturali* held in Vicenza reported about Nicolò Vlacovich's discovery. *Atti della Società Italiana di scienze naturali*. Milano: G. Bernardoni, 11: 340, 344, 380, 381, 384, 423-424. Preliminary Notes: 1867. *Congresso dei naturalisti a Vicenza*; 1868. *Annuario scientifico ed industriale*, Milano: Editori della biblioteca utile & Fratelli Treves, page 815.

Vlacovich, Nicolò. 1870. Risparmio di zinco nelle pile e metodo pratico per la riunione di moti

elementi, *Reports of Real school Trieste (Programma della Civica scuola reale superiore in Trieste, Trieste: LLOYD adriatico)*, 4-12. Reprint focused on of the experimental content of paper: 1870. *Nuovo Cimento*, series 2, 4: 5-15 (11 pages), Previous mention in the protocols of the sessions of the congress of Italian naturalists in Vicenza on 16 September 1868 (Cenno anteriore nei protocolli delle sedute del congresso dei naturalisti italiani a Vicenza nel 1868).

Vlacovich, Nicolò. 1873. Sulle macchine per i lavori in legno, e proposte per l'utilizzazione di queste e d' altre macchine per la piccola industria (On woodworking machines, and proposals for the use of these and other machines for small industry). *Weltausstellung 1873 Wien (Rapporto sull'esposizione internazionale in Vienna nel 1873 (Report on the international exhibition in Vienna in 1873)*. Vienna.

Vlacovich, Nicolò. 1875. Sulla Coppie Elettriche, *Bollettino della Società Adriatica di Scienze Naturali in Trieste*. Trieste: Lloyd austro-ungarico, 1: 129-152 (23 pages. On 2 February 1875 they read a letter from the member Mr. Nicolò Vlacovich with the woodcuts accompanying his paper already inserted in this *Bulletin* (una lettera del Socio sig. Nicolò Vlacovich, il quale chiede in prestito le silografie che accompagnano una memoria già inserita nel Bollettino)). Reprints: 1876. Teoria e pratica disposizione di alcune coppie, *Il Nuovo Cimento*, series (Serie) II, volume (tomo) 15: 93-95, 117–130; 1877. XXXIII Theorie und praktische Ordnung einige Ketten, *Poggendorff Beiblätter zu den Annalen der Physik und Chemie*. 1: 688-688 (wrongly noted *Il Nuovo Cimento* 14: 93f, 117f).

Vlacovich, Nicolò. 1876. *Relazione sulla esposizione mondiale in Vienna nell'anno 1873*, pubblicata dalla Commissione del litorale per l'esposizione in Trieste (ed. Bomches, Federico including texts authored by (redatta da Federico Bomches, testi di): Federico Bomches, Antonio Carlo Zenker, Simone de Syrski, Augusto Vierthaler, Giorgio de Gossleth, Anna Jahn Schimpff, Giuseppe Malovich, Giovanni Eichelter, Giorgio Martin, Nicolò Vlacovich, Carlo Ausserer, Vittorio Lutschaunigg, Giuseppe de Lehnert, Vittorio de Jennik, Giuseppe Hainisch, Francesco Pimser, Carlo

Willy, Giovanni Righetti, Guglielmo Urbas). Trieste: Tipografia del Lloyd austriaco, 545 pages, 23 cm.

Vlacovich, Nicolò. 1878. *Elementi di Fisica sperimentale ad uso delle scuole agrarie. Opera premiata ed approvata per l'insegnamento nelle scuole agrarie*. Trieste.

Vlacovich, Nicolò. 1880. *Elementi di Chimica ad uso delle scuole agrarie. (Opuscolo di complemento alla Fisica)*, Trieste.

Vlacovich, Nicolò. 1880. *Elementi di fisica sperimentale ad uso degli corsi inferiori delle scuole medie (approvati per l'insegnamento ne i corsi inferiori delle scuole medie e nelle scuole nautiche)*. Trieste (Comment in *Z. öst. Gym.* 31: 942). Reprint: 1888. Trieste, self-publishing (printed for the author) (comment in *Z. öst. Gym.* 39: 1144).

Vlacovich, Nicolò (Nikolaus). 1881. Über (Ueber) die Herstellung von Meidinger-Elemente (Semplificazione della coppia Meidinger). *Zeitschrift für angewandte Elektrizitätslehre*. München: R. Oldenbourg, Volume 3 (Bd. III): 48 (indexed on pp. V, XI). Notion: 1881. Herstellung von Meidinger-Elemente, *Chemisch-technisches Repertorium*. 81 (II): p. 185.

Vodnik, Valentin. 1798. On Jurij Veha (Vega), as born Carniolan, as far as I know (Rojeni Kranjec, kolikor jaz vem (Juri Veha Major per zesarških Bombardirjih, je kulikor jes vem en rojen Krajnez)). *Lublanske Novize Jann. Fridr. Egerja* (ed. Vodnik). Ljubljana: Janez Fridrih (Johann Friedrich) Eger. Volume 2 No 25: page 3 of them 8 unpagged, published on Wednesday 28 March 1798, quoting a report from Vienna on 17 March 1798 (Dunej 17. Sushza).

Vodopivec, Peter. 1971. *Luka Knafelj in štipendisti njegove ustanove*. Ljubljana: Kronika.

Voege, Willy (Willi). 1906. Ein neues Vakuummeter. *Phys. Z.* 7: 498-500.

Voigt, Gottfried. 1670. *Neu vermehrter Physicalischer Zeit-Vertreiber: darinne drey Hundert auserlesene, lustige, anmuhtige Fragen, aus dem Buch der Natur beantwortet, auch allerhand*

neue und rare Curiositäten angeführet, die Geheimnisse der Natur entdeckt, die Ursachen vieler Dinge erkläret, die Warheit befestiget, und die Irrthümer kräfttig wiederleget werden; allen Liebhabern der natürlichen Weissheit zu Nutz und Gefallen hrsg. Nebst einem dreyfachen vollständigen Register (Physicalischer Zeit-Vertreiber), Güstrow: Ch. Scheippeln / Rostock: Johann Keyln Universitäts Buchdr. & Wilden; Reprints: 1675. Rostock: Wilden's heirs; 1686. *M. Gottfried Voigts Neu-vermehrter Physicalischer Zeit-Vertreiber Darinne Drey Hundert Außerlesene/ Lustige/ Anmuhtige Fragen/ Auß dem Buch der Natur beantwortet ... warden*, Stettin: published by Johann Adam Plener & printed by Michael Höpfner's heirs (Valvasor's book).

Volčjak, Jure. 2012. *Ordinacijska protokola goriške nadškofije 1750–1824*, 2nd part: 1765–1824, Ljubljana: Arhivsko društvo Slovenije.

Volta, Alessandro. 1952. *Epistolario di Alessandro Volta. Edizione nazionale sotto gli auspici dell'Istituto lombardo di scienze e lettere e della Società italiana di fisica. Volume 3: 1788–1800* (ed. Massardi, Francesco), Bologna: N. Zanichelli.

Voronov, Gennadij Stepanovič (Воронов, Геннадий Степанович). 1985. *Штурм термоадерной крепости (Shturm termoiadernoj kreposti, Sturm of Thermal Fortification)*. Moscow: Nauka. Translation by Wadhwa, Ram Sarup (Вадхва, Рам Саруп): 1988. *Storming the fortress of fusion*. Moscow: Mir.

Vovk, Bernard. 1857. Arithmetische Progressionen. *Programm des k.k. Gymnasiums in Neustadtl (Novo Mesto) am Schuljahres 1857*. 3-30.

Vovko, Andrej. 2001. Gimnazijska leta dr. Pavla Turnerja (Grammar School Years of Dr. Paul Turner). *Studia Historica Slovenica*. 1/1: 33–52.

Vrhovec, Ivan. 1891. *Zgodovina Novega mesta*. Ljubljana.

Vrhovec, Ivan. 1903. *Zgodovina šentpeterske fare v Ljubljani. Zbornik znanstvenih in poučnih spisov Slovenske Matice* (ed. Luka Pintar) Ljubljana: Narodna tiskarna, 5: 1-88.

Vrhovec, Ivan. 1895. *Čolnarji in brodniki na Ljubljani in Savi*. Ljubljana: Slovenska Matica. Summarized reprint in similar publication: 1991. *Ljubljansko življenje na vodah (on waters)*. Ljubljana: Ceh velikih čolnarjev (Guild of the great boaters).

Vuković, Ivica; Anđić, Valent. 2016. Autori matematičkih rasprava u izvješćima rakovačke realke (The authors of mathematical discussions in the school reports at the Rakovac high school). *Prirodoslovlje. Časopis Odjela za prirodoslovlje i matematiku Matice hrvatske*. Zagreb: Matica Hrvatska. 16 (1-2) IV: 89-110.

Wagner, Kurt. 1991. *Josef Stefan ein (großer) österreichischer Physiker*. Vienna.

Wagner, Vincenz August; Joseph Ritter von Kudler; Tomaž Dolinar (Thomas Dolliner) (editors). 1839. *Oesterreichische Zeitschrift für Rechts- und Staatswissenschaft*. Wien: J.P. Sollinger. volume 3.

Waits, Robert K. May/June 1997. Edison's Vacuum Coating Patents. *AVS Newsletter*. pp. 18-19. Extended paper read at 47. international symposium of the American Vacuum Society at Boston, MA on 2-6 Oct 2000 for American Vacuum Society & International Atomic Energy Agency (IAEA): 2001. *J. Vac. Sci. Technol A* 19/4: 1666-1673.

Waits, Robert K. July/August 2000. Evolution of integrated-circuit vacuum processes: 1959-1975 (Part II of Vacuum Technology - Vacuum Contributions to the Semiconductor Industry (1950-1975)). *J. Vac. Sci. Technol. A* 18/4: 1736-1745. Correction-Erratum: 2001. *J. Vac. Sci. Technol. A* 19: 388.

Walch, Johann Georg. 1726. *Philosophisches Lexicon: Darinnen Die in allen Theilen der Philosophie, als Logic, Metaphysic, Physic, Pneumatic, Ethic, natürlichen Theologie und Rechts-Gelehrsamkeit, wie auch Politic fürkommenden Materien und Kunst-Wörter erklärt und aus der Historie erläutert; die Streitigkeiten der ältern und neuern Philosophen erzehlet, die dahin gehörigen Bücher und Schrifften angeführet, und alles nach Alphabetischer Ordnung vorgestellt werden*, Leipzig: Gleditsch.

Wallace, William Augustine. 1984. *Galileo and his sources. The Heritage of the Collegio Romano in Galileo's Science*. Princeton, New Jersey: Princeton University Press.

Wallis, John. 1673. An extract of letters from Dr. John Wallis to the publisher (Oldenburg), 1672. September 26. &c. concerning the suspension of quick silver mell purged of air, much higher than the ordinary standard in the Torricellian Experiment. *Phil.Trans.* 24 February 1672 / 1673, no. 91: pp. 5160-5170,

Wallentin, Ignaz Gustav. 1897. *Lehrbuch der Physik: für die oberen Classen der Mittelschulen und verwandter Lehranstalten: Ausgabe für Gymnasien: mit 219 in den Text gedruckten Holzschnitten und einer Spectraltafel in Farbendruck*. 11th edition. Wien: A. Pichler's Witwe & Sohn.

Wallner, Wolfgang. 2013. *200 Jahre Technik in Graz. Eine Geschichte der Technischen Universität Graz von ihren Anfängen bis in das Studienjahr 2011/12*. Graz: Verlag der Technischen Universität Graz.

Walravens, Hartmut. 2001. The Qiqi Tushuo revisited. *Missionary approaches and linguistic in mainland China and Taiwan* (ed. Ku Wei-ying). Leuven: University Press.

Warntz, William. 1989. Newton, the Newtonians, and the Geographia generalis Varenii. *Annals of the Association of American Geographers*, 79: 165-191.

Waterhouse, Benjamin. January 1805. *Cautions to young persons concerning health; in a public lecture, delivered at the close of the medical course in the chapel at Cambridge, November 29. 1804: containing the general doctrine of chronic diseases, showing the evil tendency of the use of tobacco upon young persons; more especially the pernicious effects of smoking cigarras; with observations on the use of ardent and vinous spirits in general* (pamphlet against smoking and drinking spirits). Cambridge: Helliard. Reprint: 1822. Cambridge: University Press. Translation of M. G. Kraskowitz (= Gregor Kraškovič) on 62 pages: 1808. *Vorsichtsregeln zur Erhaltung der Gesundheit der Jünglinge. Betreffend*

die allgemeinen Grundsätze der kronischen (chronischen) Krankheiten, die durch den Missbrauch (Mißbrauch) des Tabacks (Tabaks), und vorzüglich des Rauchens der gerollten Tabacksblätter (Tabaksblätter) bey jungen Personen (Leuten) entstehen: nebst Bemerkungen über den Gebrauch gebrannter Geister und Weine überhaupt. Aus dem Englischen übersetzt, und mit einer Vorrede und mit Anmerkungen versehen von M.G. Kraskowitz. Wien: Pichler. Reprint of translation: 1817. Vorsichtmaasregeln gegen den Missbrauch des Tabackrauchens und den Gebrauch gebrannter Geister und Weine überhaupt. Wien: Schräml.

Weber, Johann Adam. 1672. *Speculum naturae humanae sive discursus curiosi et fructuosi de iis, quae ad naturalem hominis constitutionem pertinent. Auctore Joanne Adamo Webero Canonico Regul. Etc.* Vienna: Georgi Leckner (NUK-GS 8285). Reprints: 1673. *Discursus curiosi & fructuosi ad praecipuas litteraturae humanae scientias illustrandas accommodati. Opus tam lectu jucundum quam fructu foecundum; in quo de macrocosmo & microcosmo, sive de magno et parvo mundo sub schemate universalis litteraturae, non minus accurate quam succincte desseritur.* Salzburg: Mayr (NUK-GS 6521, NUK-GS 25595); 1677. *Discursus curiosi et fructuosi ad praecipuas totius Litteraturae humanae scientias illustrandas accommodati: opus tam lecto sucundum, quam fructu foecundum: in quo de macrocosmo & microcosmo sive de magno et parvo mundo.* Salzburg: Mayr. Dedicated to the Viennese Provost Hieronim (FSLJ-11 g 97); 1790. *Discursus curiosi et fructuosi ad praecipuas totius Litteraturae humanae sidentias illustrandas accomodati. Opus tam lectu jucundum, quam fructu foecundum, in quo de Macrocosmo et Microcosmo sive de magno et parvo mundo sub Schemate universalis litteraturae non minus accurate quam succincte disseritur. Auctore Joanne Adamo Weber, Canonico Regul. S. Augustini etc. Editio altera.* Salzburg: Mayr (NUK-GS 4616; NMLJ). Translation: 1677-1684. *Curiose und fruchtreiche Discursen, also und dargestellt zur Erleuchtung allen menschlichen Wissenschaften eingerichtet, dass in denselben zu des curiosen Lesers sonderbarer Belustigung und Nutzbarkeit die grosse u. kleine Welt u. was darinnen Merk- u. Denkwürdiges zu betrachten vorkommt nicht weniger Grund richtig als ordentlich u. deutlich*

vorgestellt u. abgehandelt worden. Anfangs in latein. Sprache ans Licht gegeben von Johan. Adamo Webero Canonico Regul. S. August. etc. Professo. Etc. Nürnberg: Johann Hoffmann (NUK-GS 1905; NUK-GS 4759).

Weber, Heinrich Friedrich. 1888. Untersuchungen über die Strahlung fester Körper. *Berlin.Ber.* 2: 933-957.

Wecker, Johann Jacob; Alessio, Piemontese. 1750. *Joh. Jacobi Weckeri, Basiliensis, Medici Colm., De secretis libri XVII. ex variis auctoribus collecti, methodice digesti, et mizaldi Alex. Pedemontani atque portae secretis inprimis locupletati ... accessit index locupletissimus.* Basileae: Joh. Rod. Thurneisen. Derived at least in part from *De secretis libri VI* (1555. *De' secreti del reuerendo donno Alessio Piemontese, prima parte, diuisa in sei libri,* Venetia: Sigismondo Bordogna) of Girolamo Ruscelli under his pseudonym Alessio Piemontese (Alexius Pedemontanus, translated by Wecker in Basel in 1559. E. Freyer noted it as *De Secretis alchemiae Briefe*).

Wedam, Albin. 1977. Zakaj Codelli ni uspel s svojim televizijskim sistemom? *Dokumenti Slovenskega gledališkega in filmskega muzeja (Documents of the Slovenian Theater and Film Museum)* Ljubljana: SGFM. 13/29: 118-121.

Wegmann, Lienhard. 1981. Historical perspective and future trends for ion implantation systems. *Nucl. Instrum. Methods.* 189/1: 1-6.

Wehnelt, Arthur. 1905. Empfindlichkeitssteigerung der Braunschen Röhre durch Benutzung von Kathodenstrahlen geringer Geschwindigkeit. *Physikalische Zeitschrift.* 6: 732-733.

Weibl, Kastul (Caztallus, Castul). *Propositiones dogmaticae de statu mortuorum et resurgentium: atque de indulgentiis. — Labaci in aedibus d. virgini in coelos assumptae sacris, anno CID. O. CC. LXXVI (1776) mense augusto, die publicae disputadoni ex positae, a v. S. Benvenuto Philippitsch, rr. ff. Joanne Damasceno Herbitz, et illuminato minati sacri ord. min. strict. observ. ss. theolog. studentibus. Praeside p. f. Castulo Weibl*

ejusdem sacri instituti lectore generali. Labaci:
Eger.

Weichenhan, Michael. 2004. *“Ergo perit coelum...“: Die Supernova des Jahres 1572 und die Überwindung der aristotelischen Kosmologie*. Stuttgart: Franz Steiner.

Weigle, Fritz. 1962. *Die Matrikel der deutschen Nation in Siena 1573-1738*, Volumes 1-2, Tübingen: Max Niemeyer.

Weiller, Jean Lazare. 1889. Sur la vision á distance para l'électricité (Remote viewing by electricity), *Génie Civ. (Le Génie civil, The Civil Engineer)*, volume 15: 570-573.

Weiller, Jean Lazare. 16 November 1889. Sur la vision a distance par l'électricité (On distant vision by electricity). *Lum. Electr. (La Lumière Électrique, The Electric Light)*. 34: 334-336.

Weiß (Weiss), Ida. 1976. Der große Gelehrte aus der Franzkeusche. Zum Gedenken an Jožef Stefan, den aus Kärnten stammenden Begründer der österreichischen Physiker-Schule und Lehrer von Ludwig Boltzmann. In: *Die Kärntner Landsmannschaft Kultur, Land, Menschen; Beiträge zu Volkskunde, Geschichte, Gesellschaft und Naturkunde*. Heft (Volume) 10/4: 1-3. Klagenfurt: Verein Kärntner Landsmannschaft.

Weldon, Stephen. 2005. Book Review: Južnič's *Zgodovina raziskovanja vakuuma in vakuumskih tehnik I*. Ljubljana: Društvo za vakuumsko tehniko Slovenije. *Isis, Current Bibliography*. Vol. 96: 47 (no. 676).

Westritschnig, Karl Josef. 2012. *Jožef Stefan - Eine biografische Spurensuche zum 120. Todestag: Zur Erinnerung an den Physiker und Menschen aus Kärnten*. München: Grin Verlag.

Westritschnig, Karl Josef. 2015. *180. Geburtstag von Jožef Stefan: Physiker, Lehrer, Mensch*. München: Grin Verlag GmbH.

Westritschnig, Karl Josef. 2015. *Jožef Stefan: Karnten Ein Einerlei Volk*. München: Grin Verlag

GmbH / Physikalisches Institut - Akademie der Wissenschaften - Wander- und Sangesfreund.

Westritschnig, Karl Josef. 2016. *Jožef Stefan 1835-1893: Kärntner Physikpionier - Lehrer – Mensch*. Hamburg: Disserta Verlag.

Wetzer, Heinrich Joseph; Welte, Benedict; Hergenruther, Joseph Adam Gustav the cardinal; Kaulen, Franz Philipp. 1982. *Wetzer und Welte's Kirchenlexicon oder Encyclopadie der katholischen Theologie und ihrer Hulfswissenschaften*. Freiburg im Breisgau: Herder.

Wheaton, Bruce R. 1983. *The tiger and the spark, Empirical roots of wave-particle dualism*. Cambridge University Press.

Widmer, Georg. 1931. *Urkundliche Beiträge zur Geschichte des Gottscheer Ländchens 1406-1627*. Translation: 2001. *Gottschee 1406-1627 Feudal Domain on the Frontier of Empire*. Denver: Gottscheer Heritage and Genealogy Association.

Wien, Wilhelm. 1906. Reprint: 1987. Über Elektronen. *Von der Naturforschung zur Naturwissenschaft* (ed. Autrum. Hansjochem Otto). Berlin/Heidelberg: Springer, 287-308.

Weiner, Ignatz (Ignaz). 1860. Ueber die Flächen, welche die Flächen des zweiten Grades nach Linien gleicher Helle schneiden und über die Linien gleicher Helle, welche an den Flächen des zweiten Grades, wenn diese von zentralen Lichtstrahlen getroffen werden, entstehen. *Programm des Selbständige Communal-Unter-Realschule in Brünn. Veröffentlicht am Schlusse des Schul-Jahr 1859/60*. (Brno Lower Real School). Brno: heirs of Rudolf Rohrer. Pp. 3-36 and table with seven figures. Bind to director F. Mathon's: *Schulnachrichten. Veröff. am Schlusse d. Schul-Jahres 1859/60*.

Weiner, Ignatz (Ignaz). 1863. Auszug aus der Geschichte der Wärmelehre. *Programm des Selbständige Communal-Unter-Realschule in Brünn. Veröffentlicht am Schlusse des Schul-Jahr 1862/3*. (Brno Lower Real School). Brno: Carl Winiker. Pp. 3-13. Bind to director F. Mathon's: *Schulnachrichten. Veröff. am Schlusse d. Schul-Jahres 1862/3*.

Wiesenfeldt, Gerhard. 2008. The Order of Knowledge, of Instruments, and of Leiden University, ca. 1700. *Instruments in Art and Science: On the Architectonics of Cultural Boundaries in the 17th Century* (ed. Schramm, Helmar; Schwarte, Ludger; Lazardzig, Jan). Volume 2, Berlin/New York: Walter de Gruyter. 2: 222-235.

Wiesner, Julius. 1905a. *Jan Ingen-Housz Sein Leben und sein Wirken als Naturforscher und Arzt Unter Mitwirkung von Prof. Th. Escherich, Prof. E. Mach, Prof. R. von Töply und Prof. R. Wegscheider von Prof. Julius Wiesner Director des Pflanzenphysiologischen Instituts der k. k. Wiener Universität*. Wien: Carl Konegen.

Wiesner, Julius. 1905b. Jan Ingen-Housz in Wien. *Osterreichische Rundschau* (Wien: Carl Konegen). 3: 197-214.

Wilde, Emil. 1838, 1843. *Geschichte der Optik vom Ursprunge dieser Wissenschaft bis auf die gegenwärtige Zeit*, Berlin: Rucker & Püchler, volumes I and II.

Wilde, Franz Ksaver (Franc). 1860. Haupttabelle über den Zustand der Unterrichts=Anstalten im Herzogthume Krain. *Mittheilungen des historischen Vereins für Krain* (Ljubljana), pp. 65–72.

Wilson, David B. 1987. *Kelvin and Stokes*. Bristol: Adam Hilger.

Wilson, John. 1714. *Trigonometry: with an introduction to the use of both globes, and projection of the sphere in plano. To which is subjoined an appendix applying the doctrine of plain triangles to the taking of heights and distances, and to plain and Mercator's sailing*. Edinburgh: James Watson. Translation: 1718. *Principia trigonometriae succinte demonstrata*. Leiden: Peter van de Aa.

Wilson, Patrick. 1782. An experiment proposed for determining, by the aberration of the fixed stars, whether the rays of light, in pervading different media, change their velocity according to the law which results from Sir Isaac Newton's ideas concerning the cause of refraction; and for ascertaining their Velocity in every Medium whose

refractive Density is Known. *Phil.Trans.* read 24 January 1782, 62: 58-70.

Weinberg, Steven. 1983. *The discovery of subatomic particles*. New York: Scientific American Library. Reprint: 2004. Cambridge: University Press. Translation edited by Leiken, Evgeniï Moiseevich (Лейкен, Евгений Моисеевич): 1986. *Otkrytie subatomnyh častic*. Moscow: Mir.

Wiedemann, Eilhard. 1888. Ueber Fluorescenz und Phosphorescenz, 1st part (I. Abhandlung), *Ann.Phys.* 34 (270/7): 446-463; 2nd part (II. Abhandlung: Gültigkeit des Talbot'schen Gesetzes), *Ann.Phys.* 270/7: 463-469. Separate print: 1888. Leipzig: Johann Ambrosius Barth.

Wills, Ian. 2009. Edison and Science; A Curious Result. *Studies in History and Philosophy of Science*, A 40/2 (June): 157–166.

Winkelmann, Adolph (Adolf August). 1875. Ueber die Wärmeleitung der Gase. *Ann. Phys.* 156: 497-531.

Winkler, Johann Heinrich. 1738. *Institutiones Mathematico-physicae experimentis confirmatae auctore M. Jo. Henr. Wincklero*. Lipsiae: Bern. Christ. Breitkopf. German translation: 1754. *Anfangsgründe der Physik*, Leipzig: Bernard Christoph Breitkopf (NUK-8235). Dutch translation: 1768. *Beginselen der natuurkunde*. Amsterdam: Jacobus Loveringh & Abraham Blussé.

Winkler, Johann Heinrich. 1744. *Gedanken von den Eigenschaften, Wirkungen und Ursachen der Elektrizität, nebst einer Beschreibung zweo neuer Maschinen. Mit 9 Kpft*. Leipzig: Johann Heinrich Breitkopf.

Winkler, Otto Ch.; Bakish, Robert A. president of Bakish Materials Corporation, Englewood, New Jersey established in 1965 (ed.). 1971. *Vacuum metallurgy*. Amsterdam: Elsevier.

Winter, Karl. 1847. Ein neuer Electrophor-Apparat. *Berichte über (Bericht ueber) die Mittheilungen von Freunden der Naturwissenschaften in Wien*. (ed. Wilhelm Haidinger). Contains several parts including: Neue Construction von

Elektisirmaschinen (5th Meeting on 29 January 1847) 2/9 (January 1847): pp. 113-114; Elektrische Versuche (continuation, 2nd Meeting on 12 February 1847) 2/10: pp. 167-168 reprinted from *Österreichische (Oesterreichische) Blätter für Literatur und Kunst, Geschichte, Geographie, Statistik und Naturkunde* published on 19 February 1847; Elektrische Versuche (4th Meeting on 26 February 1847) 2/10: pp. 196-197 (noted in *Österreichische (Oesterreichische) Blätter für Literatur und Kunst, Geschichte, Geographie, Statistik und Naturkunde* on 5 March 1847 4/55: p. 217); Elektisirmaschine (2nd Meeting on 16 April 1847) 2/12: pp. (305), 315-316; Ein neuer Electrophor (1st Meeting on 4 June 1847) 2/14 (June 1847): pp. 449-450.

Winter, Karl. 1848. Ueber die Konstruktion eines Allgemeinen Electrophor-Apparates, *Dinglers Polytechnisches Journal*. Erster Aprilheft (first volume of April 1848), 29/108/VIII: 13-14; Also, in: 1847. *Österreichische (Oesterreichische) Blätter für Literatur und Kunst, Geschichte, Geographie, Statistik und Naturkunde*, published on 12 June 1847.

Wittenbauer, Ferdinand. 1903. *Filia hospitalis: ein Studentenstück in vier Aufzügen*. Wien: C. Konegan. Reprint: 1906. Wien: Carl Konegan.

Wittenbauer, Ferdinand. 1905. *Der Privatdozent*. Leipzig: G. Wigand.

Wittenbauer, Ferdinand. 1907–1911. *Aufgaben aus der Technischen Mechanik*, in three volumes. Berlin: J. Springer.

Wittenbauer, Ferdinand. 1923. *Graphische Dynamik ein Lehrbuch für Studierende und Ingenieure mit zahlreichen Anwendungen und Aufgaben (Grafische Dynamik)*. Berlin, Julius Springer.

Wohinz, Josef W. 2007. Nikola Tesla – ein genialer »Elektriker«. *Kunst und Wissenschaft aus Graz 1. Naturwissenschaft, Medizin und Technik aus Graz* (ed. Acham, Karl). Wien: Böhlau. 167–184.

Wolf (von Wolfe, Nathaniel Mattheaus). 1762. Descriptio fontis Hieronis in Metallifodinis Chemnicensibus in Hungaria, Anno 1756 Extracti;

Auctore - Wolfe, M. D. Communicated by Mr. Henry Baker, F. R. S. *Phil.Trans.* 1761. 52: 547-554. Table XVI.

Wolff, Christian. 1701. *Mathematischen Wissenschaften*. 4 Bände (4 volumes). Frankfurt: Renger (FSNM). Revised reprints: Wolff, Christian. 1725. *Anfangsgründe aller Mathematischen Wissenschaften*. Frankfurt. 1-4. 8^o; 1728. Franckfurt/Leipzig: Renger (KSSKL with proprietary entry „ex libris Joanni Laur: Jagsche“); 1746-1753. (*Der*) *Anfangs-Gründe aller Mathematischen Wissenschaften. Th. 1, Welcher einen Unterricht von der mathematischen Lehr-Art, die Rechen-Kunst, Geometrie, Trigonometrie und Bau-Kunst in sich enthält*; (second part) *Th. 2, Welcher die Artillerie, Fortification, Mechanick, Hydrostatick, Aerometrie und Hydraulick in sich enthält*; *Th. 3, Welcher die Optick, Catoptrick und Dioptrick, die Perspectiv, die sphärische Trigonometrie, Astronomie, Chronologie, Geographie und Gnomonick in sich enthält*; *Th. 4, Welcher so wohl die gemeine Algebra, als die Differential- und Integral-Rechnung, und einen Anhang von den vornehmsten mathematischen Schriften in sich begreifet / zu mehrerem Aufnehmen der Mathematick so wohl auf hohen als niedrigen Schulen aufgesetzt worden von Christian Freyherrn von Wolff*. 1-4. Halle und Magdeburg: Regner (NUK-4136; in UKM). Latin Translations: Wolff, Christian von. 1713. *Elementa Matheseos universæ. Tomus 1. Qui commentationem de methodo mathematica, arithmetica, geometriam, trigonometriam, analysin tam finitorum, quam infinitorum, staticam et mechanicam, hydrostaticam, aerometriam, hydraulicam complectitur. Autore Christiano Wolfio...* Halle: Johann Gottfried Renger. Reprints of Latin translation: 1715. Halle: Renger; 1717. Halle: Renger; 1732-1741. *Christiani Wolfii ... Elementa Matheseos universæ. Tomus Primus, Qui commentationem de methodo mathematica, arithmetica, geometriam, trigonometriam planam, & analysin, tam finitorum quàm Infinitorum complectitur. Editio nova, priori multo auctior et correctior...* 1-5 Genevæ: Apud Marcum-Michælem Bousquet & socios (Pellissari & H.A. Gosse); 1740-1743. *Elementa matheseos universa*. Geneve: Gosse (I part. 1743. Geneve (ST; J-451, W-1405 NUK-4240); reprint of 1st – 5th parts: 1733. Geneve: Marcus Michael Bosquet et Socios (J-436; NUK-

4049); II-IV parts (NUK 4049); reprint of II and V parts: 1741-1742. Halle: Regensiana (NUK-4073). 1747. *Elementa matheseos universae*. 5 parts. Halle/Magdeburg (ER-M67); 1774. Vindobonae: Trattner (FSNM).

Wolff, Christian. 1718. *Ratio praelectionum Wolfianarum in mathesin, et philosophiam universam*. Halle 89 km south of Magdeburg (Halaë Magdeburgicae): Renger. 8°.

Wolff, Christian. 1711. *Tabulae sinuum atque tangentium tam naturalium, quam artificialium una cum logarithmis (Logarithmic Tables)*. Halle (Halaë Magdeburgicae, Halle by Magdeburg): Joh. Godofr. Renger, 8°.

Wolff, Christian. 1711. *Zu der Trigonometrie u. Auszeihung der Wurzeln nothige Tafeln, die Sinus u. Tangentes fur jede Minute etc. Den Logarithmis den gemeinen Zahlen von 1 bis 10000 etc. enthalten sind von Christian Wolff auf der Reinigs Preuß. Fridrichs . Univers. Mathem P. P. O. etc. ...* Halle: Renger. 8° (NUK-GS 22079).

Wolff, Christian. 1731. *Cosmologia Generalis, Methodo Scientifica Pertractata, qva Ad Solidam, Inprimis Dei Atqve Natvrae, Cognitionem Via Sternitvr. Avtore Christiano Wolfio, Potentiss. Svecorum Regis, Hassiae Landgravii, Consiliario Avlico, Mathematvm Ac Philosophiae in Academia Marbvrgensi Professore Primario, Professore Petropolitano Honorario, Societatvm Regiarvm Britannicae atqve Borvssicae Sodali*. Francofvrti & Lipsiae: Officina Libraria Rengeriana. Reprints: 1736. Veronae: Dionysii Ramanzini; Francofvrti & Lipsiae: Officina Libraria Rengeriana (NUK-GS 4416 bind to: Wolff, Christian. 1736. *Philosophia prima sive Ontologia methodo scientifica pertractata, qua omnis cognitionis humanae principia continentur. Autore Christiano Wolfio, Potentissimi Suecorum Regis, Hassiae Landgravii Consiliario Regimirui etc. Editio nova priori emendatior*. Francofvrti & Lipsiae: Officina Libraria Rengeriana (NUK-GS 4419)).

Wolff, Christian. 1709. *Vernünfftige Gedancken von den Wirkungen der Natur*. 4 parts. Halle / Magdeburg. 8°. Reprint: 1746. *Vernüchtige Gedanken von der Wirkungen der Natur, den Liebhabern der*

Wahrheit mitgetheilt. Fünfte Auflage. Halle: Renger (NUK-8202; FSNM; FSLJ-2 f 69).

Wolff, Christian. 1758. *Compendium elementorum matheseos universae in usum studiosae juventutis adornatum, a Christiano Wolfio*, Tomus primus (-secundus). Translated and edited by Samuel Koenig (König) the Younger. Second edition. Lausanne & Geneve: Marc Michel Bousquet & Co. Reprint: 1782. Venetiis: apud Laurentium Basilium (POMPI).

Wolff, Christian. 1776. *Mathesis Wolfiana: in usum juventutis scholasticæ per terras hæreditarias Austriacæ domus a suprema studiorum commissione præscripta, et a cæs reg. direttore studii philosophici in compendium redacta anno MDCCLXXVI. complectens arithmetiam, geometriam, et trigonometriam, una cum algebra ad unamquamque harum partium applicata*. Wien: Johann Thomas de Trattner (FSLJ-11 e 78 with propriety entry: “Vito Mislej in memoriam datus a Dno Vincentio Gall Cler. Rep. Theol - Doctore in eiusciensi Gymnasio (= Grammar school) 4 August 1802”; FSLJ-8 c 86; NUK-GS 4169).

Wollaston, William Hyde. 1813. On a Method of Freezing at a Distance. *Philosophical Transactions of the Royal Society of London*. 103: 71–74.

Woodruff, Arthur E. 1966. William Crookes and the Radiometer. *Isis*. 57/2: 188-198.

Wretschko, Andreas (Vrečko, Andrej). 1870. Experimental-Untersuchungen über die Diffusion von Gasgemengen. *Wien.Ber.* II. 575–589.

Wretschko, Andreas (Vrečko, Andrej). 1880. *Elemente der analytischen Geometrie der Ebene: Zum Gebrauche in den oberen Classen der Mittelschulen und anderer höheren Lehranstalten, sowie zum Selbstunterrichte*. Brno: Winiker.

Wretschko, Andreas (Vrečko, Andrej). 1884. Jurij Vega by Dr. Andrej Vrečko. *Kres*, no. 1, pp. 51–56; no. 2, pp. 103–106. Modified Translation: 1885. Georg Freiherr v. Vega, Sein Leben und Wirken. *Jahresbericht des ersten deutschen k. k. Gymnasiums in Brünn für das Schuljahr 1884/5 (Jber. d. Staatsgymn. Brno 1885, The annual report*

of the Brno grammar for school year 1884/85). 1-26 (Signed in Brno on 23 June 1882).

Wüllner, Adolph. 1870. *Lehrbuch der Experimentalphysik: mit theilweiser Benutzung von Jamin's Cours de physique de l'école Polytechnique, bearbeitet von Dr. Adolph Wüllner*. 3rd edition, Leipzig: B.G. Teubner.

Yamazaki, Toshio. 1952. A catalogue of Sumitomo Library kept in Osaka Prefecture Library. *Kagakusi Kenkyu (Journal of History of Science, Japan)*. 21: 42-48.

Yarling, Charles, B.; Johnson, Walther H.; Keenan, William Andrew; Larson, Lawrence A. 1991, 1992. Uniformity Mapping and Ion Implantation. *Solid State Technol.* 34/12 (December 1991): 57-61; 35/3 (March 1992): 29-32.

Yarling, Charles, B. July/August 2000. History of industrial and commercial ion implantation 1906-1978. *J. Vac. Sci. Technol. A* 18 (4): 1746-1750.

Young, Thomas. 1802. The Bakerian Lecture: On the Theory of Light and Colours, *Phil. Trans.* 92: 12-48.

Zabarella, Giacomo. 1604. *De rebus naturalibus libri XXX. quibus quæstiones, quæ ab Aristotelis interpretibus hodie tractari solent ... discutiuntur. Editio decima, etc.* Tarvisii: Robert Meietti (FSLJ-9 b 45).

Zach, Franz Xaver von. 1984. *Briefe Franz Xaver von Zach in sein Vaterland*. (ed. Brosche, Peter; Vargha, Maria). Budapest: Department of Astronomy L. Eötvös University. Extended Translation: 2008. *The collected correspondence of Baron Franz Xaver von Zach. Volume 2, Letters from Zach to his Fatherland = Briefe Zachs in sein Vaterland 1798-1825*, Surfside, Fla.: Star Lab Press.

Zahm, Albert Francis. 1911. *Aërial Navigation: a popular treatise on the growth of Air Craft and on aëronautical meteorology*. New York & London: D. Appleton and company.

Zahn, Joannes. 1696. *Specula physico mathematica-historica notabili al mirabili scientiorum in qua*

mundi mirabilis aeconomia, non-mirifice amplius, et magnificus ... 1-2. Norimbergae: Joannis Christophori Lochner & literis Knorzianis (NUK-8462; KSSKL-Loka S 27; FSLJ-15 a 30; Ex Libris Joan: Bapt: Preschern SS. Th. & J. V. D. praepositi Labacensi now in SKLJ).

Zajc, Neža. 2011. Gabriel Gruber. *Med domom in svetom*. Ljubljana: ZRC SAZU (ed. Grdina, Igor), pp. 9-24.

Zalar, Anton. 1979. Auger electron spectroscopy (Spektroskopija Augerjevih elektronov). *DVTS. Bulletin* 17, 402.

Zalar, Anton. 22 February 1985. Improved depth resolution by sample rotation during Auger electron spectroscopy depth profiling. *Thin Solid Films*, 124/3-4: 223-230.

Zalar, Anton. 2007. Trideset let spektroskopije Augerjevih elektronov v Sloveniji (Thirty years of Auger electron spectroscopy in Slovenia). *Vakuumist* 27/1-2: 4-13.

Zalenski, Stanislaw, S.J. 1886. *Les Jésuites de la Russie-Blanche*. Paris: Letouzeu et Ané. I-II.

Zallinger zum Thurm, Franz Seraphin von. 1777. *De generali et absoluta virium mechanicarum mensura dissertatio, proposita a Francisco Zallinger, physics theoreticae et experimentalis, nec non historiae naturae, et mineralogiae in ceasereo regio Leopoldina universitate Oenipontanta professore publ. et ordin. cum ritu publico ac solemnii supremam aa. LL. ac Philos. Lauream impertiret, etc* (Dissertation on the measure of the absolute mechanical forces announced by Francisco Zallinger, the public full professor of theoretical and experimental physics, Natural History and mineralogy at royal-imperial Leopold's University Innsbruck with public exam for PhDs in philosophy). Innsbruck: J.Th. Trattner (FSLJ-3 d 64).

Zallinger zum Thurm, Franz Seraphin von. 1779. *Abhandlung von der Elektrizität des in Tyrol gefundenen Turmalins / durch Franz Zallinger zum Thurn... ; nebst den Sätzen aus der ganzen Naturlehre, nach welchen... Franz von Mayrl von Bozen, Anton Hofer von Innsbruck... auf der k.k. Universität im August geprüfet werden*. Wien:

Trattner (Carniolan Society for Argiculture and useful arts now NUK-GS I 8436/adl. 1) bind to: Mako, Paul. 1775. *Physikalische Abhandlung von den Eigenschaften des Donners und den Mitteln wider das Einschlagen / verfasst von... Mako v. Kerek-Gede... und von Joseph Edlen von Retzer... in das Deutsche übersetzt* (W-1535 now NUK-8172 without exam theses; the other copy NUK-8272 bind to Schöttl, Gregor, Maffei, Joseph, Tschokl, Anton (Čokl). 1775. *Tentamen Philosophicum* (also catalogue as NUK-8272)). Bind to: Felbiger, Johann Ignaz Melchior von. 1771. *Die Kunst Thürme oder andere Gebäude vor den schädlichen Wirkungen des Blitzes durch Ableitungen zu bewahren, angebracht an den Thurm der Saganischen Stifts- und Pfarrkirche: von dem Abt dieses Stifts... Johann Ignatz von Felbiger*, Breslau: Johann Friedrich Korn senior (dem ältern) (NUK-8173). Bind to: Zallinger zum Thurm, Franz Seraphin von. 1779. *Abhandlung von der Elektrischen Grundsätzen durch Franz Zallinger zum Thurn... ; nebst den Sätzen aus der gantzen Naturlehre, nach welchen Carl Riccabona von Reichenfels (aus Fleims), Johann Ritter von Longo, und Liebenstein, von Neumarkt, auf der k. k. Universität im August 1779 geprüft wird (Positiones ex Physica)*. Wien: k. k. Hofbuchdruckerey mit Trattnerischen Schriften (NUK-8174). Bind to: Zallinger zum Thurm, Franz von. 1779. *Abhandlung von den Überschwemmungen in Tyrol (Treatise on the flooding in Tyrol) durch Franz Zallinger zum Thurn Priester*. Innsbruck: Trattner (owned by Carniolan Society for Argiculture and useful arts now NUK-GS I 8175; other copy once Zois' book now NUK-GS I 8436; other copies bought by Styrian Agricultural society). Bind to Franz Zallinger's: 1779. *Abhandlung von der Elektrischen Grundsätzen durch Franz Zallinger zum Thurn Priester...; nebst den Sätzen aus der ganzen Naturlehre & Positiones ex physica*. Innsbruck: J.Th. Trattner (NUK-GS I 8437).

Zallinger zum Thurm, Franz Seraphin von. 1793. *Praelectiones ex Mathesi pura et adplicata, Pars 1. Mathesis pura; Pars 2. Mathesis adplicata. habitae a Francisco Zallinger*. With notes about students' exams. Augsburg: Matthäus Rieger and sons (FSLJ-5 c 69).

Zallinger zum Thurm, Jakob Anton von. 1772.

Anmerkungen über den Auszug, und die Kritik eines berlinischen... Recensenten, das Boscovichische System betreffend: Herausgegeben, als auf der kaiserl. königl. vorderösterreichischen hohen Schule zu Freyburg einigen die Magisterwürde in der Weltweisheit ertheilt wurde im Augustmonate 1772, Freiburg im Breisgau: Satron. Leopold Wisenfeldt & Leopold Biwald's Reprint: 1773. *Anmerkungen über den Auszug und die Kritik eines Berlinischen Herrn. Recensenten das Boscovichische System betreffend, herausgeben als auf der kaiserl. königl. vorderösterreichischen hohen Schule zu Freyburg einigen (hohen Schule zu Freyburg einiges) die Magisterwürde in der Weltweisheit erheilet wurd*, Grätz: Widmanstadii (Widmanstetter). *Assertiones ex universa Philosophia... , Graecii MDCCLXXIII. Ex praelectionibus Adm. Rev. & Cl. P. Leopoldi Biwald, e S. I. AA. LL. & Phil. Doct. eiusd. Prof. publ. & ord. Adm. Rev. & Cl. P. Antonii Pöller, e S. I. AA. LL. & Phil. Doct. eiusd. Prof. publ. & ord. A. R. & Cl. P. Leopoldi Wisenfeld, e S. I. AA. LL. & Phil. Doct. ac. Phil. Moral. Prof. publ. & ord. Adm. Rev. & Cl. P. Caroli Taupe, e S. I. AA. LL. & Math. Prof. publ. & ord. 8^o*. Graz (NUK-8304 by Čop's catalogue p. 45). Latin translation: *Animadversionem in Extractum et Crisin Censoris Berolinensis circa Systema Boscovich, Graecii, 1775* (Sodnik-Zupanec, 1962, p. 284).

Zallinger zum Thurm, Jakob Anton von, 1773. *Interpretatio Naturae, seu philosophia Newtoniana methodo exposita, et academicis usibus adcommodata. III Tomos continet*. Augustae Vindelicorum/Vienna: Joseph Wolff (NUK-8161, brown covers, greened edges of leaves, not Zois's book; FSLJ-5 c 68-71).

Zallinger zum Thurm, Johann Baptist von. 1769. *Abhandlung von den schleunig- und zuverlässlichsten Hilfsmitteln den Ackerbau in Lande Tyrol zu verbessern und zu vermehren, wie auch dem anscheinenden Holzmangel durch Beförderung des Nachwachses werkhätig zu steuern*. 1-3 Theil (3 parts in one volume of 100 pages). 1 copperplate. Wien: Trattner (NUK-GS 9666).

Zallinger zum Thurm, Johann Baptist von. 1771. *De viribus materiae Dissertatio physica proposita a p. Joan. Bapt. Zallinger...; cum positiones*

philosophicas propugnaret ... Jos. Liber baron de Sternbach... Oeniponti. Graecii: Widmanstetter (FSNM). Reprint: 1775. De viribus materiae dissertatio physica: Ex editione oenipontana recusa / Joan Bapt. Zallinger. Graecii: haered. Widmanstadii (Widmanstetter, MINSPT of Friars minor conventuals form Ptuj).

Zanchi, Joseph. 1748. *Scientia rerum Naturalium sive Physica ad usus academicos accomodata, Tom I. & II. Tom I. partem generalem complectens. Tom II. partem speciatem continens, opera et studio P. Josephi Zanchi Societatis Jesu Sacerdotis. Physica P. Josephi Zanchi e Soc. Jesu: inscripta honoribus serenissimi regnii principis Caroli Alexandri Ducis Lotharingiae... dum in ... Universitate Viennensi ... Joannes Comes Patatich de Zajesda ... universam philosophiam publice propugnaret, ex praelectionibus ejusdem R. P. Josephi Zanchi... M. DCC. XLVIII. Tomus primus et secundus in uno volume. Viennae: Kaliwoda (W-1466 now NUK-8479, ST; Erberg's Physics-F61-XCVII).*

Zantedeschi, Francesco. 1848. Ueber die Bewegungen der Flamme unter elektromagnetischem Einfluss. *Ann. Phys.* 73: 286-290.

Zeising (Zeisingk, Zeisenck), Heinrich. 1607-1614, *Theatri Machinarum*. Leipzig: Henning Grosse junior. 6 volumes, among them first three published up to 1612 as Zeising's work stated by his friend Grosse, while the other volumes were Megiser's translations from French and Italian languages into German language as the addition to the first three volumes. In later editions all volumes were mostly attributed to Megiser.

Zendrini, Bernardo. 1715. Modo di ritrovare ne' fiumi la linea di corrosione, i quali si escavano negli argini composti di parti ammovibili, qualora il corso delle loro acque sia in qualche maniera alla direzione delle sponde obliquo, *Giornale de' letterati D'Italia* (ed. Zeno, Apostolo; Zeno; Pietro Caterino. Venezia: Giovanni Gabbriello Ertz (Hertz)). Volume 21: 121-136.

Zenneck, Jonathan. 1899. Eine Methode zur Demonstration und Photographie von Stromcurven. *Ann. Phys.* 69: 838-853.

Ziegler, Jakob; Gaius Plinius Secundus; Georg Tannstetter Collimitius; Joachim Vadianus. 1531. *In C. Plinii De naturali historia librum secundum commentarius, Qvo Difficvltates Plinianae, Praesertim Astronomicae, Omnes Tollvntvr; Item Organvm Qvo catholica Sydervm, Vt Apvd Plinivm Est, Mira Arte Docetvr. Item, Georgii Collimittii, Et Ioachimi Vadiani, in eundem secundum Plinij scholia quaedam: ... Opus nunc recens natum, & primum aeditum* Basileae: Henric Petri (contained commentarius in librum 2 Plinii de Astronomia).

Ziliotto, Baccio. 1904. Gianrinaldo Carli e Giuseppe Tartini. *Pagine istriane*. 2/7: 225–236.

Ziliotto, Baccio. 1912. Trecentosessantasei lettere di G. R. Carli capodistriano, cavate dagli originali ad annozate. *Archeografo triestino* (third part). Serie 3. 6: 227–340

Zinsmeister, Gilbert J. 1983. Die Entwicklung der industriellen Dünnschicht-Technik. *Festkolloquium anlässlich des 75. Geburtstages von Herrn Max Auwärter. Aus dem akademischen Leben der Technischen Universität Wien*, Wien: Technische Universität (5), pp. 35-74 Reprint: 1984. Die Entwicklung der industriellen Dünnschicht-Technik. *Vacuum-Technik*. volume 33.

Zoch, Johan (Ivan Branimir). 1880. Neue elektrische Staubfiguren als Betrag zur Erklärungen der Erscheinungen in der Geisler'schen Röhren und zur Widerlegung der Crookes'schen Hypothese (Nove električne figure-prašine kao pokušaj objašnjavanja pojava u Geislerovim cijevima i pobijanja Crookesove hipoteze, New electrical powder-figures as an attempt to explain the phenomena in Geisler's tubes and to refute Crookes' hypothesis. *Godišnje izvješće c. kralj. Realne Gimnazije u Sarajevu koncem prve školske godine 1879/80 (Prva muška sarajevska gimnazija, Reports of imperial-royal Real Gymnasium in Sarajevo)*. Volume 1.

Zoch, Johan (Ivan Branimir). 1889. Kratak nacrt poviesti matematike i fizike, *Izviješće o kr. Maloj realci u Petrinji za šk. god. 1889./90.*, 3-60. Separate print: 1889. Zagreb: Narodne novine.

- Zoch, Johan (Ivan Branimir). 1895. Teslin sustav za prenašanje munjevine energije (Tesla's System for the Distribution of Electrical Energy). *Školski vjesnik: stručni list zemaljske vlade za Bosnu i Hercegovinu*, volume 2: pp. 239-241, 318-320.
- Zorić, Ivana. 2010. *Fotografije iz Teslinog albuma*. Beograd: Muzej Nikole Tesle.
- Zupančič, Črt. 2000. Zgodba o prvi jedrski meritvi v Ljubljani. *Pripovedi o IJS* (ur. Osredkar, Milan; Polenec, Natalija). 76-80.
- Zwinger, Theodor. 1565. *Theatrum Vitae Humanae*, volumes 1- 2, Basel: Ioan. Oporinus, brothers Ambrosius & Aurelius Froben (NUK-GS 4806). Second edition: 1571. *Theatrum Vitae Humanae, omnium fere eorum, quae in hominem cadere possunt, bonorum atq malorum exempla historica Ethicae Philosophiae praeceptis accommodata et in XIX. libros digesta, comprehendens: A Conrado Lycosthene- jam pridem inchoatum: nunc vero Theod. Zwingeri, Philosophi & Medici Basiliensis opera- eo usq deductum, ut omnium ordinum hominibus ad vitam praeclare instituendam utile- sit futurum. Cum gemino indice*, Basileae: Froben (NUK-GS 5052).
- Zwitter, Fran. 1962. *Nacionalni problemi v habsburški monarhiji*. Ljubljana: SM.
- Zworykin, Vladimir Kosma, Ramberg, Edward Granville. 1950. *Photoelectricity and its application*. New York: John Wiley & Sons, Inc.
- Zworykin, Vladimir Kosma, Ramberg, Edward Granville, Flory, Leslie Earl. 1958. *Television in Science and Industry*. New York: John Wiley.
- Žagar-Jagrov, Jože. 1983. *Kostel, Ljudje in zemlja ob Kolpi*. Kočevje (Gottschee): Kulturna skupnost občine.
- Žargi, Matija. 2001. Potres v Ljubljani in usoda Auerspergovega knežjega dvorca (Earthquake in Ljubljana), *Melikov Zbornik (Melik's anthology)*, (ed. Rajšp, Vincenc; Bratož, Rajko; Cvirn, Janez; Fischer, Jasna; Lukan, Walter; Marušič, Branko). Ljubljana: ZRC SAZU, 749-756.
- Žargi, Matija. 2002. Auerspergov knežji dvorec (Auersperg's princely mansion), In: *Theatrum Vitae et Mortis Humanae* (ed. Dular, Anja; Žvanut, Maja). Ljubljana: Narodni Muzej.
- Žitko, Salvator. 1994. Vloga in pomen Collegia dei nobili v Kopru. *Acta Histriae* (Koper & Milje: Zgodovinsko društvo za Južno Primorsko) 2/3: 123–132.
- Žitko, Salvator. 1997. Carlijevo delovanje v koprskih akademijah 18. stoletja. *Acta Histriae*, 5/5: 59–78.
- Žitko, Salvator. 2004. Il ruolo di Gianrinaldo Carli nell'affermazione delle Accademie di Capodistria nel XVIII secolo. Gianrinaldo Carli nella cultura europea del suo tempo (ed. Trampus, Antonio). *Quaderni Giuliani di Storia* (Trieste). Anno XXV: 155-171.
- Žižek, Aleksander. 2015. *ABC Arhivska Barbara Celjska*. Celje: Zgodovinski arhiv & Pokrajinski muzej.
- Žmavc, Ksenija. 2010. Najstarejši zapisi in besedila o slovenski tehniški dediščini do začetka 19. stoletja. *Zgodovina strojništva in tehnike na Slovenskem* (ed. Kalin, Mitjan). Ljubljana: Fakulteta za strojništvo. 46-60.
- Žontar, Jože. 1982. *Zgodovina mesta Kranja*. Kranj: Skupščina občine.
- Žubričić, Darko. 2017. Školovanje Nikole Tesle u Hrvatskoj i njegov profesor Martin Sekulić (Scholing of Nikola Tesla in Croatia and his professor Martin Sekulić). *Povijest i filozofija tehnike / radovi EDZ* (Elektrotehničko društvo Zagreb) *sekcije 2017. godine (History and philosophy of technology - works of the EDZ section in 2017)*, (ed. Benčić, Zvonko; Moser, Josip). Zagreb: Kiklos / Denona d.o.o., pp. 81-117.
- Županc Mežnar, Lea. 16 March 1996. Luminiscentne snovi (I part), *Vakuumist* 16/3: 14-19.
- Žvab, Andraž Marjan. 2016. Baročna alkimija na Kranjskem (Baroque Alchemy in Carniola). *Kronika*. 64/2: 199–224.

Žvanut, Maja. 2009. *Plemiške zgodbe kranjsko plemstvo v šestnajstem in sedemnajstem stoletju (Noble Stories)*, Ljubljana: Viharnik.

37.4 Index of Main Patents Noted

Aitken, *Russel (of Falkirch, England)*. 1884.

Apparatus for extracting gases from molten metals (The degassing of steam and the pumping of molten steel through a tap into emptied receiver due to the difficulties in removing gas from molten metal). He used a special container with an insulating layer for the refraction of light, and the suction hose was placed on the bottom. The container was immersed in the frying pans during alternating suction and injection of the air. Part of the melt could be sucked into a special container to gradually decompose the solution. Patented in England in March 1882 as No. 1,533, in France on September 29, 1882 as No. 151,315, in Germany by No. 22,170 on October 12, 1882, in Austria-Hungary on February 24, 1883 as No. 35,676 and No. 7,515. US patent US310012A was granted on December 30, 1884.

von Ardenne, Manfred. 1924. The Receiver and Transmitter with cathode ray tube. German Patent.

Arsem, William C. (at GE headquarters in Schenectady). 1904. Electrodeposition, Application filed by Priority to US21809704A on 25 July 1904, Application granted by Publication of US811759A on 6 February 1906.

Arsem, William C. (at GE headquarters in Schenectady). 1904. Electric furnace (having an air-tight chamber, A vacuum resistive metal cleaning agent by evaporating impurities, promoting metallurgical gas reactions, and protecting reactive metals against pollution, a vacuum water-cooled metal degassing vessel, a spiral graphite heater and a graphite screen), US Serial No. 220 449 filled 12 August 1904.

Arsem, William C. (at GE headquarters in Schenectady). 1906. Chemical process (mixing an oxide of tungsten with a dry powdered reducing agent and then heating said mixture in a vacuum by radiant heat to cause reduction of said oxide, various separation metallurgical operations at temperatures above 1500 ° C), Priority to US1906324408A on 2 July 1906, Application filed by Priority to US393227A on 16 September 1907, Application

granted by Publication of US979363A on 20 December 1910.

Auwärter, Max. 1939 for Heraeus (after 1946 for Liechtenstein's Balzers). The rhodium vapour deposited mirrors. German Patent in 1939. Similar: Production of metallic surface layers (Rhodium coatings characterized by a surprisingly high reflecting power and an extremely adhesive strength to the basis, extremely uniform surface of rhodium upon the glass which may be further fixed by polishing, partially permeable to light and forms a mirror of considerable reflecting power), Priority to DE478916X on 10 December 1936, Auwärter filled US application on 19 April 1937, Application granted by Publication of US2422609A on 17 June 1947.

Auwärter, Max. 1949. Double layer Transmax (antireflection coating). German Patent in 1949; Similar: Reactive deposition of thin films, British patent 697403 in April 1952.

Auwärter, Max. 1952. Process for the manufacture of thin films, Priority to Austrian patent AT2920002X of 25 June 1952, Auwärter's Balzers application claiming priority by serial no. 362,792 on June 19, 1953, Application granted by Publication of US2920002A on 5 January 1960.

Baird, John Logie. 1927. Improvements in or relating to the Transmission and/or Reproduction of Views, Scenes. or Images by Wires or Wirelessly (stereoscopic wired or wireless transmission of images or motion. One or two spiral lenses and photocells put around the rotating Nipkow-disc). British patent no. 266,564, applied on September 1, 1925 under no. 21,846/25, completed on July 1, 1926, granted on March 1, 1927.

Baird, John Logie. 1936. A color television (with 120 lines scanned with Nipkow plates in red, green and blue colors), British patent no. 473323 filled on 5 April 1936, 16 March 1937, granted on 11 October 1937.

Balmain, William Henry (of Eversley, Ventnor, Isle of Wight, in the county of Hants, England). November 7, 1877. Self-luminous paint (Painting, Varnishing etc., procedure for production of

Balmain's colour), English patent no. 4,152 on November 7, 1877 (*The Engineer* 1877 July-December: Patent Journal on 7 December 1877, p. 414). Patented in Victoria on December 31, 1879 by No. 2,766; in Italy on December 31, 1880; in Belgium January 3, 1881, No. 53,483; in Tasmania March 21, 1881, No. 192; in New Zealand April 28, 1881, No. 523; in Spain May 21, 1881, No. 1,455; in Sweden June 18, 1881; in New South Wales June 25, 1881, No. 947; in Queensland July 12, 1881, No. 354; in Portugal July 21, 1881, No. 688; in Austria December 7, 1881, No. 33,137. On 26 September 1882 Application granted by Publication of US264918A (by Harriet Fox, the executrix of deceased Balmain).

Bardeen, John; Brattain, Walter Houser (both for Nokia Bell Labs). 1948. Three-electrode circuit element utilizing semiconductive materials (Transistor). Priority to US11168A on 26 February 1948, US Application filed on 17 June 1948, Application granted by Publication of US2524035A on 10 March 1950.

Bell, Alexander Graham (of Washington, District of Columbia); Tainter, Charles Symner (of Watertown, county of Middlesex, State of Massachusetts). 1880. Photo phone-transmitter (Telephone, selenium in photophone), United States Letters Patent filed on August 25, 1880 for apparatus transmitting sound or reproducing it at a distant point by the agency of rays from the sun, application for Photo phone-transmitter filled in September 1880, Application granted-issued by Publication of US235496A on 14 December 1880. Bell's speech before the American Association for the Advancement of Science in Boston on August 27, 1880.

Bell, Alexander Graham; Tainter, Charles Symner. 1880. Selenium Cell, US Patent filed in September 1880, Application granted-issued by Publication of US235497A on 14 December 1880.

Bessemer, Henry. 1855. His first converter (converting steel in crucibles), British patent no. 2321 filled on October 17, 1855. Corresponding with: The conversion of molten crude iron ... into steel or malleable iron, without the use of fuel, applied by US patents 16082 dated 11 November 1856, and 16083, dated 18 November 1856. William

Kelly from the Suwanee Iron Works, Eddyville, Kentucky with the help of his Chinese metallurgy experts achieved a similar US patent no. 17,628 in 1857.

Bessemer, Henry (of London). 1865. The use of models in an empty space into which the liquid steel or iron was applied using atmospheric pressure for the "extraction of iron and steel without burning materials". British patent on 27 July 1865. Improvement in machinery for the manufacture of iron and steel, Application granted by Publication of US49055A on 25 July 1865.

Bethe, Hans Albrecht (of Santa Fe, New Mexico, for United States of America as represented by Secretary of War). 1945. Directional coupler, USA patent 2519734 applied by Priority to US590047A on 24 April 1945, Application granted by Publication of US2519734A on 22 August 1950. Similar Bethe's inventions associated with a hydrogen bomb patented in US in 1949.

Betterton, Jesse Oatman. 1923. Recovering Metal (by permanently attached emptied receiver in the melting furnace), Serial No. 648,194 patent application filed by priority to US64819523 on June 28, 1923, application granted by publication of US1605641A on November 12, 1923.

Betterton, Jesse Oatman of Omaha, Nebraska (& Philips, Albert J., & Metuchen, N. J.), assignor to American Smelting and Refining Company, New York, a corporation of New Jersey. 1936. Vacuum treatment of metals. USA patent no. 2,054,922 on September 22, 1936 and no. 2,140,607 on September 22, 1936.

Blackwell, Otto Bernard (from Plandome northeast of Queen in New York city); Herman, Joseph from New York as assignors to American telephone and telegraph company (ATT). 1925. Method and Apparatus for Television (Spiral scanning), Applied for US patent no US1624918A on May 7, 1925, granted-published on 19 April 1927.

Booth, Hubert Cecil. 1901. Improvements relating to the extraction of dust from carpets and other materials (Motorized vacuum cleaner). Noted on 18 February 1901, Application filed on August 30, 1901

with priority to GB190117433T, application granted by Publication of GB190117433A on 17 July 1902.

Bose, Jagadish Chandra (Jagadis Chunder); Bull Chapman, Sara. 1901. Detector for electrical disturbances (first crystal detector of microwaves), US Application filed on September 30, 1901 by Serial No. 77.028 with priority to US7702801A, Application granted by Publication of US755840A on March 29, 1904.

Bourdon, Eugène. 1849. Improved pressure gauge without mercury (Aneroid metallic tube pressure gauge). Patent applied in Paris on 18 June 1849 granted on 3 August 1853. USA Letters Patent No. 9,163, dated August 3, 1852.

Bower, Robert W. 1966. Field-effect device with insulated gate as basic patent describing the self aligned-gate MOSFET (Self- aligned gates with aluminium gates made at low temperatures), patent filed on May 2, 1966, US3472712 issued on October 14, 1969.

Bronk, Otto von (for Telefunken). 1902. Method and device for making images or objects visible from a distance while temporarily dissolving the images in parallel rows of dots as a color television set whose signals are transmitted in the three primary colors (A mirror drum, a selenium cell and a Geissler tube filter with color filters). German patent DE155528 filled 12 June 1902, granted 22 October 1904.

Burger, Reinhold. 1901. Device for generating X-rays (X-ray cathode ray tube). Patent DE129974 registered on April 19, 1901, published on April 22, 1902.

Burger, Reinhold (for his Berlin company R. Burger & Co. in Germany). 1903. Vessel with double walls enclosing an air-free cavity, Patent DE170057 (DRP no. 170057) registered by the Imperial Patent Office on October 1, 1903, published April 25, 1906. Patents granted in Switzerland, France, Great Britain (United Kingdom), Canada and the USA followed in 1906. The name "Thermos" was protected in 1904 as a trademark under the serial number 71717, registered on August 30, 1904 in the Berliner Imperial Patent Office.

Burns, Laurence (for Sylvania Electric Products Inc. at Salem, Massachusetts). 1944, 1948. Nonactinic fluorescent lamp (GTE Sylvania's first light emitting diode), application filed with Priority to US568737A on 18 December 1944, application granted by publication of US2452518A on 26 October 1948.

Codelli, baron Anton von Fahnenfeld & his brother-in-law Ernst Stadler von Wolfersgruen. 1898. Tube-igniter for explosive-engines (Glowing plugs for internal-combustion engines, electric lighter for motor vehicles), patented as Codelli's first invention. Application filed by priority granted as US1100600A on 31 March 1900, application granted by publication of US653341A on 10 July 1900. Patent sold later in 1900 to the French company Collin Dufresne (Collin-Dufresne et Berigot, Colin) which operated in 1899-1900.

Codelli, baron Anton. 1906. A rotary explosive engine, the predecessor of a half-century later engine of Felix Wankel. Extended by: Codelli, baron Anton (Moste, near Laibach). 1920. Rotary apparatus.

Codelli, baron Anton. 1920. Refrigerator (pipe filled with a liquefied gas and immersed in the liquid to be cooled, the cooling action being produced by the vaporization of the liquefied gas on the pipe being opened by aid of a suitable opener), application filled by priority to US399399A on 27 July 1920, Application Number: US399399A filed on 28 July 1920, noted on 9 November 1920, Application granted by publication of US1467462A on 11 September 1923.

Codelli, baron Anton. 1903. Small heating and cooling apparatus for motorists on long journeys (special container keeping food first frozen and then heated to the desired temperature before use). French patent filled in Nice in France. Extended by: Codelli. 1922. Miniature cooling apparatus (comprising a reservoir filled with a liquefied gas connected to evaporator permitting a gradual escape of the liquefied gas into the evaporator from which the vaporized gas then escapes), application filed by Priority to US531427A on 24 January 1922, Application granted by Publication of US1468876A on 25 September 1923.

Codelli, baron Anton. 1928. Used the term electron for a cathode ray, although he also repeatedly wrote about the cathode ray deflection in his typewritten application for US Patent application on 18 May 1928 and on June 18, 1928. Codelli patented his invention in Germany as the reproduction of images along the spiral. In 1928 and 1931, Codelli patented his stereoscopic electric "far-sighted" vision in all major European centers and in Canada, including: patent application No. 7546 Kingdom of Yugoslavia (Kraljevina Jugoslavija), June 7, 1929 (Copy in SI_AS; NUK, manuscript section, Reference code: Ms. 1397; SI_ZALj) and the Electrical Television, British patent 334,243 on 28 May 1929 & 30 August 1930. Due to the incorrect filling and irregular application on 25 June 1927 and on 29 December 1930, under no. 60718, Codelli's patent in the USA was rejected on 18 August 1932.

Colby, Edward Allen. 1890. Electric furnace for melting metals (foundations of modern vacuum induction melting furnace from an emptied receiver). USA patent. Electric induction furnace of the type set), application granted by publication of Letters Patent US428378A on May 20, 1890

Colby, Edward Allen (Newark, in the county of Essex of New Jersey, for American electric furnace Co. of New York). 1905. Electric Furnaces having endless cores having melting channel only, application filed with priority to US28863005A on 23 November 1905, Application granted by Publication of US859641A on 9 July 1907.

Coolidge (for GE (General Electric Co.) in Cleveland, Ohio). 1909, 1913. Tungsten and method of making the same for use as filaments of incandescent electric lamps and for other purposes (the production of tungsten that could be pulled into thin wires, which did not hang down). 1912-06-19 Priority to US1912704580, 1913-12-30 Application granted with publication of US1082933A.

Daguerre, Louis. 1839. Daguerre's rights were acquired by the French Government in exchange for lifetime pensions while on 19 August 1839, the French Government presented the invention as French gift "free to the world" by complete working instructions published, but in mid-August 1839 Daguerre's agent Miles Berry filled for patent

applied to "England, Wales, and the town of Berwick-upon-Tweed, and in all her Majesty's Colonies and Plantations abroad" No. 8194 of 1839 entitled: "A New or Improved Method of Obtaining the Spontaneous Reproduction of all the Images Received in the Focus of the Camera Obscura". Grove subsequently defended the "Daguerreotype" patent in England as a lawyer in court although he had a hard time obtaining Daguerre's plates in England because of that same patent.

Déri, Miksa; Bláthy, Ottó; Zipernowsky, Károly. 1886. Induction Coil, application granted by publication of patent US352105A issued on 2 November 1886.

Detela, Andrej; Lampič, Gorazd. 2011. Električni stroj z zmanjšanim držalnim navorom in drhtenjem navora ter nespremenjeno konstanto navora: patent 23406 A. Ljubljana: Urad RS za intelektualno lastnino, 30. december 2011, Patentna prijava P-201000171, 2010-06-09 (Electric machine with reduced holding torque and torque vibration and unchanged torque constant: patent 23406 A. Ljubljana: Office of the Republic of Slovenia for Intellectual Property, 30 Dec. 2011, Patent Application P-201000171, 2010-06-09).

Dieckmann, Max; Glage, Gustav (both in Strasbourg). September 12, 1906. Method of transferring characters and line drawings using the cathode ray tube. German Reich Patent application no. 190102.

Dieckmann, Max; Hell, Rudolf. 1927. Photoelectric imaging tube for television, German Patent No. 450187 issued on 3 October 1927.

Dill, Hans G. (for Hughes's Aircraft Company Newport Beach in California). 1966. Self-aligned gates FET. Tested polycrystalline silicon on May 1, 1966, filed US patent 3,544,3999 on 26 October 1966.

Dufour, Corinne (of Savannah in Georgia). 1900. Electric Carpet Sweeper and Dust Gatherer (motor operating as a suction-fan), Application filed by priority to US2542500A on 31 July 1900, Application granted by publication of US664135A on 18 December 1900.

Dunwoody, Henry Harrison Chase. 1906. Wireless-telegraph system (carborundum (silicid of carbon) detector), patent filed on March 28, 1906, 1906-03-23 Priority to US30767906A, 1906-12-04 Publication of US837616A. Greenleaf Whittier Pickard had served as an expert witness for Dunwoody in patent cases. Crystal detector was patented independently by the Berlin Telefunken in connection with Robert von Lieben in 1906.

Dyson, James (for his UK Dyson technology LTD). 1980, 1983. Handles for hand-supported suction cleaners (G-force Vacuum cleaner). 1980-03-26 Priority to GB8010098, 1981-03-24 Application filed for EU patent, 1981-10-14 Publication of EP0037674A1, 1985-08-07 Application granted by Publication of EP0037674B1. US Patent 4,593,429 in 1986.

Edison, Thomas Alva. 1875, 1885. "Ethereal force". Edison drafted, but did not file, a patent application for an "etheric telegraph (thermionic emission)". For *Means for transmitting signals electrically* he filled US patent 465,971 on 23 May 1885, issued on 29 December 1891.

Edison, Thomas Alva. 1879. Electric Lamp (light bulb with charcoaled cotton thread), according to the legend burned for 40 hours, although laboratory notes testify only 30.5 hours. On 4 November 1879, a patent application was filed, which only had to wait for 84 days for US Patent no. 223,898 on January 27, 1880. The invention was patented in England in February 1879.

Edison, Thomas Alva. 1882. Method of treating carbons for electric lights, Application granted by Publication of US265777A on October 10, 1882.

Edison, Thomas Alva. 1885. Incandescent Electric Lamp (adsorption of mercury and water from a vacuum with special tubes filled with different getters), applications granted by publications of US317631A, US317632A, and US317633A on 12 May 1885.

Edison, Thomas Alva. 1884. Art of plating one material with another (coating with evaporation in vacuum by straight heating with a direct current,

which he called "electro vacuum deposition" for arc deposition), application filed January 28, 1884 with Serial No. 118,942, Application granted by Publication of US526147A on 18 September 1894.

Edison, Thomas Alva. 1896, 1907. Fluorescent electric lamp. 1902-04-29 Application filed with priority to US10523302A, 1907-09-10 Publication of US865367A.

Edison, Thomas Alva. 1897, 1899. Tested glowing material from charcoal particles mixed with rare earth oxides, patented in March 1897. Continued as: Filament for incandescent lamps and process of manufacturing same (highly refractory oxides of the rare earths including zirconium, thorium, incorporate therein the isolated particles of carbon by a process of carbonization) 1899-06-06 Application granted by Publication of US626460A.

Edison, Thomas Alva. 1900. Process of coating phonograph-records (Phonograph plates overlay procedure), 1900-06-16 Application filed with priority to US2055500A, Application granted by publication of US713863A on 18 November 1902.

Edison, Thomas Alva. 1903, 1904. Apparatus for vacuously depositing metals (first metallization process with cathode sputtering for production of phonograph plates). 1903-08-01 Application filed with priority to US16793003A, 1904-08-09 Publication of US767216A

Edison, Thomas Alva. 1915. Filament for incandescent electric lamps (Production of a tungsten electrode by pressing tungsten powder in an oxygen-free container evaporating tungsten by discharges between electrodes). 1907-05-31 Application filed by General Electric Co, 1907-05-31 Priority to US37661907A, Publication of US1163329A on 7 December 1915.

Ekström, Alfred. 1910. Arrangement related to photos (recording and receiving the image along the spiral, Anordning for of verforande af bilder pa asstand). Swedish patent no. 32220 filled on 24 January 1910, issued on 3 February 1912.

Farnsworth, Philo Taylor (for Mesne Assignments to Television Laboratories, Inc. of San Francisco,

California, A Corporation of California). 1927. Television System (camera tube). USA Patent 1,773,980 filed on January 7, 1927, granted on August 25, 1930 after a long battle with corporate giants.

Farnsworth, Philo Taylor (Mesne Assignments to Television Laboratories, Inc. of San Francisco, A Corporation of California). 1930. Cathode ray tube providing the display tube the receiver as the television screen, Patent 1,773,981 obtained on August 26, 1930.

Flehsig, Werner. 1938. Cathode ray tube for production of multicoloured images on a fluorescent screen (shadow mask). German Reich patent 736,575 filed July 12, 1938 and issued May 13, 1943.

Fleuss, Henry Albert. 1892. Compression or exhaust pump (Geryke's piston pump sealed with oil equipped with mechanical displacement dampers). German patent granted in 1893. USA application filed in December 1892, letters patent US517337A published on March 27, 1894.

Fleischer, Emil (from Dresden-Altstadt, for Dellwik-Fliescher Wassergas-Gesellschaft of Frankfurt). 1914. The process of manufacturing producer-gas. German patent in 1914. US Application with Serial No. 838,347 filed by Priority to US83834714A on May 13, 1914, 1918-07-23 Application granted by publication of US1273474A.

Fleming, John Ambrose. 1905. Instrument for converting alternating electric currents into continuous currents (thermionic valve as diode). 1905-11-07 Application granted by Publication of US803684A, Great Britain patent 24850.

Forest, Lee de. 1906. Oscillation-responsive device, patent filed 19 May, granted 13 November 190 as patent US836070.

Forest, Lee de. 1906, 1908. Wireless Telegraphy (audion as a stolen Fleming's diode with a grid making a triode), on November 13, 1906 as Audion patent US841386, a triode version patented in 1908 as US879532.

Gaede, Max Paul Wolfgang. 1913. Mercury diffusion pump, German patent 286404 on 9 September 1913. Method and apparatus for producing high vacuums, US Patent 1069408, issued on 5 August 1913.

Gaede, Max Paul Wolfgang. 1921, 1923. Diffusion pump with a plurality of different pressure levels forming jet nozzles (vacuum pump without moving parts, circular-acting motorized diffusion pumps with a mercury piston), 1921-10-01 Application filed by Priority to DEG57118D, 1925-07-06 Application granted by publication of DE416065C.

Gassner, Carl, 1885, 1886. Gael gassier (Cells with aqueous electrolyte, Leclanché's "dry cell"), German patent obtained on 8 April 1886. USA Application granted by publication of US373064A on 15 November 1887. Patents in Austria-Hungary, Belgium, France and England.

Geiger, Paul Harold (assistant director of research from Ann Arbor, Michigan in 1926, from Wilkinsburg, Pa. in 1929, for Union Switch & Signal Company, Swissvale, Pa., a Corporation of Pennsylvania). 1926, 1929. Manufacture of copper oxide rectifiers (The first photocell with copper-Cu₂O insulating layer of the kind claimed by Grondahl's patent US1640335A), invented on 14 November 1926, 1929-10-09 Application filed with priority to US398576A, 1931-12-01 Publication of US1834275A.

Goebel, Heinrich (Göbel, Henry). 1882. Vacuum Pump (Improvement of the Geissler-System of vacuum pumps. USA patent US252.658A obtained on January 24, 1882.

Goebel, Heinrich (Göbel, Henry). 1882. Electric Incandescent Lamp (sockets to connect the filament of carbon and the conducting wires), patent US266.358A obtained on October 24, 1882.

Gordon, Robert H. (of Beading in the county of Berks, Pennsylvania). 1883. Apparatus for Treating Molten Metal (Modeling of ingots in a vacuum), Application granted by publication of US287273A on October 23, 1883.

Grabovski, Boris Pavlovič (Grabowski, Борис Пáвлович Грабóвский); Popov, Viktor Ivanovič (Виктор Иванович Попов); Piskunov, Nikolai Georgievich (Николай Георгиевич Пискунов). 1925. Radio device for vision at a distance (Радиоустройство для видения на расстоянии, Description of the apparatus for electric telescoping), filed November 9, 1925 with application certificate No. 4899, Soviet Union Patent for invention No. 5592 issued in Leningrad on June 30, 1928.

Grabovski, Boris Pavlovič (Grabowski, Борис Пáвлович Грабóвский); Beljanski Ivan F. (Belyansky, Иван Филиппович Белянский) (in Tashkent). Telephoto (телефото), Soviet Union patent on 28 July 1928.

Greyl, Zaharias (Greil). 1720. Swift fire extinguishing machine for cooking with extinguishing bomb (Löschbombe). City of Augsburg granted the official patent (Copia Attestati) on 16 April 1720 and 30 October 1720.

Grondahl, Lars Olai (from Pittsburgh, Pennsylvania for Union Switch & Signal Company). 1925. Unidirectional current-carrying device (copper oxide rectifiers), 1925-01-07 Application filed with priority to US1111A, 1927-07-01 Priority claimed from US202811A, Publication of US1640335A on 23 August 1927.

Gunder, Jeane D. (for the J. A. Pozzoni Pharmacal Company based in Chicago). 19 April 1912. Puff Box (titanium nitride in powder form). US Patent filed on 19 April 1912, Serial No. 691,955.

Gunder, Jeane D. 1915. Box (with fluting, scrolls and shield on the top with beading on its sides). Chicago, Ill. Patent filed on May 28, 1915, Serial No. 31,000.

Hall, Howard Tracy (filled by GE). 1954. 1955. Diamond synthesis (Presses using a plurality of pressing members working in different directions). 1955-08-29 Application filed with Priority to US530935A, 1960-08-02 Application granted by Publication of US2947608A.

Hampson, William. 1895. Improvements relating to the progressive refrigerating of gases (Liquefaction of air), British patent 10165, 23 May 1895.

Hanaman, Franjo (Ferencz); Just, Alexander. 1903. Process for production of incandescent bodies made of tungsten or molybdenum for electric incandescent lamps. German patent DRP 154262 obtained on April 1903. Hungarian patents No. 34541 in Budapest on 7 October 1904, 13 December 1904 and 6 June 1905, Austrian patent AT 20.888 on 15 February 1905, British patent "Improvement relating to the Manufacture of Incandescent Electric Lamps" GB 23.899 on 29 July 1905, patented "Process for Manufacture of Incandescent Bodies for Electric Lamps" as US 855.060 on 4 February 1907.

Hass, Georg H. (Danzig Institute of Technology). 1940, 1941. Silicon Monoxide Protected Front-Surface Aluminium Mirrors (aluminum oxide layers, Aluminiumoxydschichten). German patented process classified as a top-secret during WW2.

Heil, Oskar. 1935. Improvements in or relating to electrical amplifiers and other control arrangements and devices (MOSFET using modern theory of electrons and holes), British Patent No. 439, 457 Filed March 5, 1935, issued December 6, 1935.

Hinsdale, William R. (from Brooklyn, N. Y. for Compressed Steel Company of Cleveland, Ohio. 1885). Casting system that excluded the atmosphere and could be used for production of steel. German patent. Fluid Metal Press (Pressure casting making use of mechanical pressure devices as cast-forging). USA Patent Application granted and published as US332656A on 15 December 1885.

Hlubek, Peter (owned factory in Villingen, Baden). 1868-1869. Calculator using tooth wheels. Patented in German language. Resembled Thomas T. Strode's patent

Hlubek, Peter (owned factory in Villingen, Baden). 1875. Piston pump (Eine eigentümliche Konstruktion von Kolbenmotoren). Patented in Vienna. Noted in Landesarchiv Baden-Württemberg, Staatsarchiv Ludwigsburg.

Holweck, Ferdinand. 1914, 1924 (. Thermionic apparatus (thermionic tubes). In 25 June 1924 French Patent FR1660381X, on 18 June 1925 US Application filed, on 28 February 1928-Publication of US1660381A.

Holweck, Ferdinand. 1922. Molecular Pump (Spiral drum-type molecular drag pump, Pompe moléculaire). French Patent 609813 applied on 2 May 1925, published on 2 August 1926.

Hummel de Bourdon, Karl Ludwig. 1822-1827. Apparatus designed to peel and crush the grapes at the same time (Weintrauben zu glechen zeit abzubeeren und zu zerquetschen). Viennese patent held from 25 August 1822 until 1827.

Hummel de Bourdon, Karl Ludwig. 1822-1827. Joiner of timbers (Tischlerhölzer). Viennese patent held from 30 September 1824 until 1833.

Hull, Albert (for by General Electric Co.). 1920. Electric discharge device (Magnetron). On 29 January 1920 application filed with priority to US354914A, on 20 January 1925 Publication of US1523776A.

Inman, George Elmer (for GE). 1936. Electric discharge lamp (Fluorescent lamp). Filed on April 22, 1936. Granted on October 14, 1941 as U.S. Patent 2,259,040.

Ives, Herbert E. 1926. Television, patent applied in USA on May 20, 1926 under number 110,378, granted on December 3, 1929 by US no. 1,738,007.

Jablochkoff, Pavel Nikolayevich (Yablochkov (Jabločkov, Павел Николаевич Яблочков). 1876. Electric candle. French patent No. 112024 granted on 23 March 1876.

Jablochkoff, Pavel Nikolayevich (Yablochkov (Jabločkov, Павел Николаевич Яблочков). 1876. Arrangement of currents, intended for lighting by electric light (Disposition de courants, destinée à l'éclairage par la lumière électrique), French patent No.115793 granted on November 30, 1876.

Jacob, Josef (Jacobs, Viennese mine owner); Köller, Franz (Koeller, PhD in chemistry, Reichraming

Gußstahlhütte). 1855. Production of Tungsten Steel, French patent in 1855, Viennese patent applied on 10 March 1858 by no. 7676 (Austrian Patent office (Patentamt) volume 7 folio 76) granted on May 10, 1858 by no. 11775.

Jenkins, Charles Francis. 1925, 1926. Twin light-cell transmitter (Remote cinema). US Patent 1642730, registered on 21 March 1925, granted on 20 September 1927.

Jenko, Monika; Vodopivec, Franc; Osojnik, Andreja. 1994. *Processing non-oriented electrical sheet metal*, Patent SI 9210326 A, filled for the Institute of Metallic Materials and Technologies, Lepi pot 11, Ljubljana: Office of the Republic of Slovenia for the Protection of Industrial Property, Date of application 30 March 1992, date of publication 30 June 1994 (A process for the treatment of non-oriented electroplate is carried out by applying a thin layer of antimony in the amount prior to and during final annealing for decarburization and recrystallization in such an amount that activated recrystallization and grain growth take place during decarburization. and crystallization so that this sheet contains from 0.001 to 0.05% Sb after annealing for decarburization and recrystallization).

Junkar, Ita; Kralj-Iglič, Veronika; Štukelj, Roman; Zaplotnik, Rok; Mozetič, Miran. 2019. Method for treatment of tools and tools used for isolation of microvesicles, nanovesicles or exsomes. European patent specification EP 3 185 921 B1, 2019-09-04. München: European Patent Office.

Karolus, August. 1924. Method for inertialess light control via Kerr effect (*Verfahren zur tragheitsfreien Lichtsteuerung mittels Kerr-Effekt, Improved photocell of Scotsman Kerr to modulate fluctuations of light in a television set*). On June 21, 1924, he received a German patent no. 471720.

Karolus, August. 1929. Device for image transmission and television with synchronously switched cell grids, German application number K 0113831 on March 9, 1929, on 21 February 1933 Publication of DE 19290308.

Kennedy, Rankin. 1882. Cathode ray tube with electrodes covered with phosphorescent material, which glowed after bombardment with cathode "rays". English patent.

Kennedy, Rankin. 1888. Transformation and distribution of electric energy. On 21 February 1888 application granted by publication of US378321A.

Kenney, David T. (of North Plainfield in the county of Somerset and State of New Jersey, for Vacuum Cleaner Co.). 1901. Apparatus for removing dust, Application filed by priority to US8405801A on 29 November 1901, Priority claimed from US93187A and from US93188A on 8 February 1902, Priority claimed from US263344A on 1 June 1905, Application granted by Publication of US847947A on 19 March 1907.

Kerwin, Robert Eugene; Klein Donald L.; John C. Sarace (of Somerset, N.J.) (for Nokia Bell Labs Murray Hill, NJ). 1967. Method for making MIS structures (self aligned gates), US Patent 3,475,234, filed on 27 March 1967 and awarded on 28 October 1969.

Kilby, Jack StClair. 1959. Miniaturized Electronic Circuits (first integrated circuit, microchip), U.S. Patent 3,138,743 filed on February 6, 1959.

Paul Kirchhoff (diploma engineer from Frankfurt on Main). 1925. Spiral scanning, filed German patent on 6 September 1925 and on 7 October 1930, granted on 14 August 1936 in Berlin.

Klasens, Hendrik Anne; Haaijman, Pieter Willem; Dam, R. W. (for Philips). 1955. Method of Producing Semiconducting Materials (barium titanate), West German Patent 929,350 on June 23, 1955.

Klasens, Hendrik Anne. (Emmasingel in Eindhoven, Philips Research Laboratories, Laboratoria N.V. Philips' Gloeilampenfabrieken, US Philips Corp. New York). June 1, 1964. Improved procedure for production of a thin-film transistor (Method of manufacturing semiconductor devices and semiconductor devices manufactured by such methods), on 20 June 1963 gilled Holland patent NL294370, on 1 June 1964 US application filed, on

6 May 1969 application granted by publication of US3442647A.

Kolar, Metod; Vesel, Alenka; Modic, Martina; Junkar, Ita; Stana-Kleinschek, Karin; Mozetič, Miran. 2020. *Method for immobilization of heparin on a polymeric material*. European patent specification EP 2997984 B1, 2020-06-03. Munich: European Patent Office.

Kovač, Janez; Dahle, Sebastian; Žigon, Jure; Petrič, Marko; Da Cortà, Giuseppe. 27 September 2019. A plasma device and a method for generating plasma: patent application in Luxembourg no. LU101420. Luxembourg: Patent Office.

Kroll, William Justin (Guillaume Justine). 1922. Process for the separation and recovery of metals from metal alloys (Industrial process separating antimony, bismuth, arsenic, tellurium from lead alloys), on 12 September 1920 application filed with priority to US41175120, on 5 September 1922 publication of US1428041A.

Kroll, William Justin. 1925. Process for separating individual metals from metal mixtures, German patent DE410533C published on 1925-03-09.

Lake, Henry Harris. 1891. Improvements in and the relating to steam boilers and other furnaces, English patent no. 13620 on 12 August 1891, noted at *The Mining Journal, Railway and Commercial Gazette*, Volume 61, Part 2 (22 August 1891) No. 2922: p. 962.

Lane-Fox, St. George William Pitt. 1878. Electric Lighting. British letter patents no. 3988 dated 9 October 1878 & no. 4626 dated 14 November 1878.

Langmuir, Irving (Schenectady, N. Y., assignor to General Electric Company). 1919. Vacuum-pump. Applied in US in 1916, US1320874 patent granted on 4 November 1919.

Langmuir, Irving (Schenectady, N. Y., assignor to General Electric Company). 1921. Method and means for obtaining High Vacua, the patent US1393550 granted on 11 October 1921.

Lasič, Danilo D.; Belič, Andrej (for Liposome Technology, Inc.). 1993. Method for instant preparation of a drug containing large unilamellar vesicles, filed February 28, 1990, USA Patent number 5185154 granted on February 9, 1993.

Leithäuser (Leithäuser), Gustav; Mrosek, Herbert (Fraunhofer-Institut Berlin-Charlottenburg). 1934. Method for modulating electrical vibrations (Verfahren zur Modulation elektrischer Schwingungen), Applied for German Patent on July 8, 1934 by application number DEL86191D, DE656604C published on 2 November 1938.

Lieben, Robert von. 1906. Cathode ray relay. DRP (German Reich Patent) no. 179807 applied on 4 March 1906, issued on 17 November 1906.

Lieben, Robert von; Reisz, Eugen; Strauss, Siegmund. 1910. Relay for undulating currents, in which an ionizer is influenced by the current fluctuations to be amplified (Telephone relay for undulating currents), DRP no. 236716 applied on September 4, 1910, published on 11 July 1911.

Lieben, Robert von; Reisz, Eugen; Strauss, Siegmund. 1910. Relay for undulating currents (Relais für undulierende Ströme, So-called lattice patent), addition to DRP 236716 as DRP no. 249142 applied on December 20, 1910, published on 12 July 1912.

Lilienfeld, Julius Edgar. 1926. Method and apparatus for controlling electric currents, U.S. patent No. 1,745,175, filed October 8, 1926, confirmed-issued January 18, 1930.

Lilienfeld, Julius Edgar. 1928. Device for controlling electric current, U.S. Patent No. 1,900,018 filed on March 28, 1928, confirmed-issued on March 7, 1933.

Lilienfeld, Julius Edgar. 1928. Amplifier for electric currents, U.S. Patent no. 1877140, filed on 8 December 1928, confirmed on 13 September 1932.

Linde, Carl. 1895. Process for the liquefaction of atmospheric air or other gases, German patent 88824, applied on June 5, 1895, issued on 29 September 1896.

Lisle, Emile Armet de (for his Parisian Société anonyme (=Corporation) Françaises dite Banque du Radium). 1910. Luminescent sulfides illuminating upon radiating by radium in the vacuum. Belgium patent.

Lisle, Emile Armet de; Curie, Maurice; Varinois, Marcel-Ernest. 1919. Method and apparatus for producing images or luminous matter and its application in advertising and cinematography, on 10 May 1919 application filed with priority to FR546990T, on 28 November 1922 publication of FR546990A. Extended by: Curie, Maurice; Varinois, Marcel-Ernest. 1920. Apparatus for production of luminous images and the like, on 19 May 1920 USA application filed with priority to US38267420, on 30 May 1922 publication of US1418240A.

Lodigin, Alexander Nikolaevich (Lodyguine, Александр Николаевич Лодыгин). 1872. Illuminant for Incandescent Lamps, applied for a Russian patent in 1872, granted on 11 July 1874 with Russian patent number 1619, also patented in Austria, France, and Belgium. Electric light, GB 3,809 patent on December 14, 1872 (with Stanislav Konn). Illuminant for Incandescent Lamps, US application filed on 4 January 1893 4,1893 by serial no. 457,221, US Patent No. 575,002 applied and published on 12 January 1897.

Loeff (Löff), S. 1830. Syphon coffee method as a vacuum pot system, patented in Berlin.

Maré, Baltzar Emil Leo de junior. 1938. Method and apparatus for deoxidizing and degasifying liquid steel (vacuum degassing of the molten metal stream during casting or pouring), patented in US and Sweden on August 20, 1938. He submitted a patent for vacuum degassing of the molten metal stream during casting or pouring, applied in Sweden on September 18, 1939, granted on September 18, 1939 as SE2253421X by Serial No. 295,491. On 18 September 1939 USA application US295491A filed, on August 19, 1941 publication of US2253421A.

May, E. (probably Edmund, for Loom & machine factory formerly May & Kühling in Chemnitz). 1896. Crucible for underfeeding (Tiegel für

Unterfeuerung), German patent no. 90267 dated 11 January 1896.

May, E. (Edmund May for Loom & machine factory formerly May & Kühling in Chemnitz; Webstuhl- & Maschinenfabrik vormals May & Moritz Kühling). 1897. Burner for gasifying liquid fuels from a container with an inlet pipe and an overflow nozzle (Device for simultaneous casting of five models in an emptied receiver, Utility model Entries, burner consisting of 5 individual carburettors becoming the burner pot in one line with the shut-off valve switched on), noted as: Aus einem Behälter mit Zuflußrohr und Ueberlauffutzen bestehender Brenner zur Vergasung flüssiger Brennstoffe; Gebrauchsmuster. Eintragungen. Gekanntgemacht im (announced in) *Deutscher Reichsanzeiger und Preußischer Staatsanzeiger (State Gazette)*. Berlin: Kessel, no. 97 on 26 April 1897, German patent no. 73466 dated 17 March 1897 (W. 5228; *Patentblatt Bekanntmachungen auf Grund des Patentgesetzes und des Gesetzes betreffend den Schutz von Gebrauchsmustern Herausgegeben vom Reichspatentamt* no. 17 dated 28 April 1897, pp. 346, 352-353; Freytag, 1898, 57).

McGaffey, Ives W. (from Chicago, Illinois). 1869. Improved sweeping-machine (Whirlwind as wood and canvas contraption as the manually powered vacuum cleaner which cleaned rugs), patent US91145A applied and granted on June 8, 1869.

Michelssen, Fritz (for Telefunken AG, Telefunken Society for Wireless Telegraphy mbH). 1931. Luminescent screen (using zinc-cadmium sulfide for yellow and green luminescence in the right proportions, a mixture of zinc sulfide for light blue luminescence and of zinc-cadmium sulfide producing a red fluorescence results in a vivid purple or violet color), on 20 August 1931 priority to DE1988605X, US application filed on 19 August 1932, on 22 January 1935 granted by publication of US1988605A.

Michelssen, Fritz; Schleede, Arthur (both for Telefunken AG, Telefunken Society for Wireless Telegraphy mbH). 1931. Luminescent screen in discharge tubes, e.g. Braun tubes (Chalcogenides with zinc cadmium, Lumineszenzschirm in Entladungsröhren, z.B. Braunschen Röhren), on

21 August 1931 application filed by Priority to DET39349D, on 25 November 1935 application granted with publication of DE622302C.

Miessner, Benjamin J. (US naval radio station Washington D.C, formally district of Columbia). 1910. Detector for wireless apparatus (Braun's electrode with a conductor as a crystal detector for radio as the Cat's whisker detector that enabled reception of radio waves by crystal sets), Application filed on 5 October 1910, on 5 October 1910 priority to US58548410A, on 21 July 1914 Publication of US1104065A.

Moleyns, Frederick de (William Mullins). 21 August 1841. Production or development of electricity; and application of electricity for obtaining light and motion (Jobard's electricity applied for illumination). British patent no. 9053.

Monckton, Edward Henry Cradock (from Fineshade Abbey, Northants) & Weatherdon, Baldwin Fulford (Civil Engineer from of Kingston-upon-Thames, Surrey). 16 September 1862. A new or improved engine for obtaining and applying motive power, British patent note no. 2538 recorded in the Londoner Office of the Commissioners of Patents for Inventions on September 16, 1862 and published in *The London Gazette* on September 26, 1862 p. 4673.

Morris, Timothy & Weare, Robert (both Electricians from Birmingham at Warwickshire) & Monckton, Edward Henry Cradock. 19 May 1862. Improvements in obtaining and applying light and heat by electricity (Geissler's cathode ray tube for lighting). British patent notice no. 1516 recorded in the Londoner Office of the Commissioners of Patents for Inventions on 19 May 1862 and published in *The London Gazette* on September 30, 1862 pp. 4688-4689.

Moyer, James Wallace (for Knolls Atomic power lab of GE in Schenectady, eastern New York). June 1954. Method of making p-n junction semiconductor unit (Power Efficiency for the Photovoltaic Effect in a Germanium Grown Junction), US patent 2842466 (serial no. 436816) filed on 15 June 1954, issued on 8 July 1958.

Mozetič, Miran (some his group's recent patents are listed); Vesel, Alenka. 2001. Konfiguracija elektrod v ionski vakuumski črpalki. Patentna prijava: P-200100084, 2001-03-26. Ljubljana: Urad Republike Slovenije za intelektualno lastnino (Title Electrode configuration in an ion vacuum pump: Slovenian patent application: P-200100084, 2001-03-26. Ljubljana: Office of the Republic of Slovenia for Intellectual Property)

Mozetič, Miran; Vesel, Alenka. 2002. Ionska vakuumska črpalka z novo konfiguracijo elektrod: patent SI 20840 (A), 2002-08-31. Ljubljana: Urad Republike Slovenije za intelektualno lastnino, Št. prijave P-200200102, 2002-04-18 (Ionic vacuum pump with new electrode configuration, Slovenian patent: SI 20840 (A), 2002-08-31. Ljubljana: Office of the Republic of Slovenia for Intellectual Property, No. of application P-200200102, 2002-04-18).

Nagler, Josef. 1935. Electro-optical control for cameras, cinemas, and copiers (Elektrooptische steuerung für Photo-, Kino- und Kopierapparate).

Nagler, Josef. 1935. Color television with three-color cell resolution (Gebiet des Farbfernsehens mit Dreifarbenzellenauflösung). Negotiations with the US company Standard Electric were so protracted that this patent expired. His receiver for electronic color TV was developed by Baird in a color television with 120 lines scanned with Nipkow plates in red, green, and blue colors in 1936.

Nagler, Josef; his son *Josef Nagler Junior*. 1953. Verfahren und Einrichtung zur Erzeugung von Farbfernseh-Sendungen (subjektive *Farbfernsehen*, Method and device for generating color television programs as subjective color television by Gustav Theodor Fechner-Benham phenomenon), *Austrian patent AT755194X on 11 November 1953. Also West German, Denmark, and UK patents. Method and apparatus for producing color effects in projected pictures, on 8 November 1954 application filed in USA, on 18 July 1958 application granted by publication of US2844990A.*

Nardin, Julius; Zei, René. 1912. Relais für elektrische Ströme (Stand-alone relay for electrical currents applicable to telephones and telegraphs, especially useful for submarine cables), Austrian

patent (Österreichische Patentschrift) no. 66604, registered-applied on 13 August 1912 with effect granted on 15 June 1913, issued on September 10, 1914.

Navinšek, Boris; Žabkar, Anton. 1983. Večsektorska vroča komora za reaktivno ionsko prekrivanje, Slovenski patent, rubrum 20286-P-1588/83 (Multisectoral hot chamber for reactive ion coating, Slovenian patent, rubrum (=red) 20286-P-1588/83).

Navinšek, Boris. 1984. JOSTiN® - blagovna znamka, patent rubrum št. 15508-Ž-315 (Brand: use of hard protective titanium nitride coatings in industrial production of Navinšek's Ljubljana Group, which protected the domestic thin-film technology with the patent and the trademark JOSTiN (JOSTiN®) in twenty-three countries of Europe in 1983. Applications trademarks of that brand abroad might have been protected through the Slovenian firm SMELT, which was then the majority owner of the Navinšek's Center for Hard Coatings of IJS).

Navinšek, Boris; Žabkar, Anton. 1990. Zaščitne trde prevleke titanovega nitrída, pripravljene z reaktivnim ionskim prekrivanjem, patent-rubrum 202887-P-1589 (a983). Podeljen patent: Postopek za nanašanje plasti titanovega nitrída z reaktivnim ionskim prekrivanjem«; št. patenta C23C 14/46 z dne 25.5.1990 (Protective hard coatings of titanium nitride prepared by reactive ion coating, patent rubrum 202887-P-1589 (a983). Patent granted for a Process for applying a layer of titanium nitride by reactive ion coating, patent no. C23C 14/46 of May 25, 1990).

Navinšek, Boris; Krušič, Janko. 1997. *Postopek za površinsko utrjevanje zobnih modelov s trdo prevleko*. Patent št. SI 9500347A (Procedure for surface hardening of hard-coated dental models. Slovenian patent no. SI 9500347A).

Navinšek, Boris; Panjan, Peter. 1997. *Postopek za nanašanje prevleke iz kromovega nitrída z reaktivnim ionskim prekrivanjem*. Patent št. SI 9500341 (*Method for applying chromium nitride coating with reactive ion coating*. Slovenian patent no. SI 9500341).

Navinšek, Boris; Panjan, Peter. 1999. *Postopek nanašanja prevleke iz niklja z ionskim prekrivanjem na telesu iz aluminija*. Patent št. SI 9700325.

Ljubljana: Urad republike Slovenije za intelektualno lastnino (*Method for applying an ion-coated nickel coating to an aluminum body*). Slovenian patent no. SI 9700325. Ljubljana: Office of the Republic of Slovenia for Intellectual Property).

Nemanič, Vincenc; Žumer, Marko; Mrzel, Aleš; Remškar, Maja; Mihailović, Dragan. 2004. *Uporaba kvazienodimenzionalnih ternarnih spojin prehodnih kovin in kvazienodimenzionalnih spojin halkogenidov prehodnih kovin kot emiterjev elektronov*: patent : SI 21289 (A), 2004-02-29.

Ljubljana: Urad RS za intelektualno lastnino (Use of quasi one dimensional transition metal ternary compounds and quasi one dimensional transition metal chalcogeneide compounds as electron emitters, Slovenian patent : SI 21289). Numbers of applications: P-200200189, 2002-08-02; WO 2004/013884 (A1), 2004-02-12; EP 1540687 (A1), 2005-01-31; US 2006/231825 (A1), 2006-06-15

Nemanič, Vincenc; Žumer, Marko; Zajec, Bojan; Kocmur, Miha, 2008. Poljski mikroskop za preiskavo emisijskih mest na površini ravnih hladnih katod, patent SI 22425 (A), 2008-06-30 (Field microscope for examination of emission areas on the surface of cold flat cathodes). Ljubljana: Urad RS za intelektualno lastnino. Number of application P-200600263, 2006-11-02

Nicolson, Alexander McLean (Nicholson, from New York). 1917. Television (Recording and receiving the image along the spiral), US patent no. 1470696 filled on 7 December 1917 granted on October 16, 1923; British patents no 228961 and no. 230401 filled on 7 September 1923 and granted on 16 October 1923.

Nipkow, Paul. 1884. Elektrisches Telescope (Electric telescope), January 6, 1884 (or January 8) application filed as priority to DE188430105, on 15 January 1885 application granted by publication of DE30105C, Nipkow received 25 marks on February 8, 1884.

Nollet, Floris; issued on his behalf by Edward Clarence Shepard (Shephard). 1850. Electro-

magnetic apparatus suitable for production of motive power (a practical AC generator), British patent 13302 on October 24, 1850. Shepard's Patent of Electro-Magnetic and Heat, Light and Motive Power Machines noted at: 1851. *Mechanics' Magazine, museum, register, journal, and gazette*. London: Robertson, Brooman & Co. edited by R.A.

Brooman, July 3-December 25, 1851, 57/1448: pp. 358, 362-364, 410-411.

Nollet, Floris; issued by Edward Clarence Shepard. 1851. Obtaining and applying motive power, British patent no. 13727 sealed on 28 August 1851 for six months.

Nollet, Floris; issued by Edward Clarence Shepard. 1852. Improvements in electro-magnetic apparatus suitable for the production of motive power, of heat, and of light (Apparatus for lighting in a vacuum by the incandescence of charcoal, Verwendung von Kohle im Vakuum), French patent no. 11649 on April 26, 1851 with addition on April 24, 1852; British patent no. 14197 by Shepard's communication on July 6, 1852 and no. 1587 on July 1, 1853.

Nollet, Floris (Florise, professor of Physics in the Brussels Military School (École Militaire), after 1855 his heritage was used by the Societé l'Alliance (Alliance Company) formed with Auguste Berlioz as director and Nollet's co-worker Joseph van Malderen as chief engineer); issued by English patent agent and inventor Edward Clarence Shepard of Duke Street Westminster-London on the late Nollet's behalf in England and France. 1850, 1858, 1861-1862. Charcoal filament in vacuum bulbs. Edward Clarence Shepard of Victoria street, Westminster, British letter patent for the invention of an improved apparatus for carburating gas for gas lighting; petition recorded in the Office of the Commissioners on the 9 January 1861 (The London Gazette, January 25, 1861 Page 2 no. 56). Magneto-electric machine for electric light, and street-lamp carburator presented at London international exhibition in 1862.

Noyce, Robert N. (for Fairchild Semiconductor Corporation). 1959. Semiconductor device-and-lead structure (rectifier, describing a planar integrated circuit and using Hoerni's ideas), filed priority to US830507A on July 30, 1959, 30 June 1960 priority

claimed from Fairchild Semiconductor Corporation's patent FR831640A, granted-accepted by publication of US2981877A on 25 April 1961.

Ohl, Russell Shoemaker (by Nokia Bell Labs). 1941. Light-sensitive electric device, 1941-05-27 Application filed with priority to Ohl's patent US395410A, on 17 September 1942 Priority to Ohl's patent US45870942, on 17 January 1944 priority to patent of Western Electric Co Inc. GB90744A, on 25 June 1946 publication of US2402662A.

Ohl, Russell Shoemaker (for Nokia Bell Labs). 1950. Semiconductor translating device (first patent for the bombardment by oxygen, hydrogen, nitrogen, helium, argon, CO, and even CHCl_3 in the production of semiconductor devices), on 11 January 1950 Priority claimed from the patent US137906A of Ohl's colleague William G. Pfann of Nokia Bell Labs, on 31 January 1950 application filed with priority to US141512A, in 12 June 1956 publication of US2750541A.

Panjan, Matjaž; Čekada, Miha; Panjan, Peter; Matelič, Damjan; Mohar, Andrej; Sirk, Tomaž; Fišer, Jožko. May 31, 2012. Trde zaščitne prevleke z možnostjo spreminjanja njihove barve. Patent SI 23538 A. Ljubljana: Urad RS za intelektualno lastnino, Patentna prijava P-201000399, 2010-11-22 (Hard protective coatings with the possibility of changing their color: Slovenian patent SI 23538 A. Ljubljana: Office of the Republic of Slovenia for Intellectual Property, Patent Application P-201000399, 2010-11-22).

Pickard, Greenleaf Whittier. 1906. Means for receiving intelligence communicated by electric waves (silicon crystal detector). Filed a patent on August 30, 1906 which was granted on November 20, 1906 by publication US836531A.

Pirani Marcello von (subject of the King of Italy, residing at Wilmsdorf by Berlin for Berliner Siemens and Halske AG). 1907. Process for producing technically pure ductile tantalum (melting of tantalum and other metals in electron beam of concentrated cathode rays), on 23 June 1906 application filed with priority to US32313306A, on 17 September 1907 Publication of US866385A in the United States.

Polumordvinov, Alexander Appolonovich of Kazan. 1899. Light distributor for a device used to transmit images at a distance with all colors and their shades and all shadows (color television system with rotating Nipkow plates and concentric cylinders with slits covered with red, green and blue filters). On December 23, 1899 (January 5, 1900) applied for a patent for his invention № 10739 to the Department of Trade and Manufactures of the Ministry of Finance of Russia. Security certificate № 9839 was dated February 27, 1906. Baird bought a patent from Polumordvinov.

Popov, Viktor Ivanovič; Grabovski, Boris Pavlovič; Piskunov, Nikolai Georgievič (in Saratov). 1925, 1930. Distance vision radio (радио-устройство для виденья на расстояниях), Application certificate dated November 9, 1925 under the number 4899, and on August 30, 1928 a Soviet Union patent was issued under the number 5592 inside class 21 a1 32 with Rosing's help. After the work in Tashkent in 1928 Grabovski and his assistant Beljanski, Ivan Filipovich filed bettered Russian patent No. 16733, class 21 a1 32, 35 for the Description of the apparatus for electric telescoping Telephoto (Телефот), granted on 30 October 1930.

Primc, Gregor; Mozetič, Miran; Zaplotnik, Rok; Vesel, Alenka; Ravnikar, Maja; Žel, Jana; Mehle, Nataša; Gutiérrez-Aguirre, Ion; Filipić, Arijana; Dobnik, David. 2018. Method for deactivation of a virus in water: patent application number 1821107.8. London: Intellectual Property Office.

Primc, Gregor; Mozetič, Miran; Vesel, Alenka; Lehocký, Marián; Stloukal, Petr; Sedlarik, Vladimír; Humpolíček, Petr. 19 December 2018. Device and method for producing UV radiation: patent EP3168860 applied 2017-05-17. München: European Patent Office.

Primc, Gregor; Mozetič, Miran; Cvelbar, Uroš; Vesel, Alenka. 11 June 2019. Method and device for detection and measuring the density of neutral atoms of hydrogen, oxygen, or nitrogen. European patent specification EP 3 146 327 B1. Munich: European Patent Office.

Richard, Jean (or Jeanne). 1825, 1837/1838. Vacuum coffee siphon (Cona type vacuum coffee maker made its appearance; two globes on top of each other, attached to a stand, functioning by air pressure) by French patent in 1837/1838, recognizing priority of the Berlin-based company Loeff in 1830.

Rignoux, Georges-Pierre-Édouard. 1906. Device for transmitting images of objects remotely (Appareil destiné à transmettre à distance les images des objets), French patent application February 10, 1906, Patent granted August 16, 1906 under no. 364,189.

Rignoux, Georges-Pierre-Édouard. 1906. Apparatus intended for transmitting images of objects remotely (Appareil destiné à transmettre à distance les images des objets), French Patent application on December 10, 1906. Patent granted on February 10, 1908 as no 382,535.

Rignoux, Georges-Pierre-Édouard. 1908. Apparatus intended for transmitting images of objects and animated views at a distance (Appareil destinés à transmettre à distances les images des objets et des vues animées, sixty-four selenium cells interconnected on the scanner contact plate at téléphoto), French Patent no. 390,435 filed May 20, 1908, issued October 5 1908.

Roberts, Martyn John. 1852. Obtaining light, motion, etc. by the agency of electricity (catalogued as Incandescent lamp), patented as GB 14198 on July 6, 1852.

Rohn, Wilhelm Julius Paul (from Hanau). 1920. Process for making parts for the manufacture of high-vacuum tubes and the like. USA patent 1555316 filled on 14 May 1920.

Rohn, Wilhelm Julius Paul. 1925. Nickel-chromium-iron alloy and articles made therefrom, on 23 November 1925 priority to DE1736053X, on 16 September 1927 application filed, on 19 November 1929 publication of US1736053A.

Rohn, Wilhelm Julius Paul (for Heraeus Vacuumschmelze AG). 1931. Method of producing chromium (production of pure metal by direct reduction of chromium oxide by hydrogen), on 15

April 1931 priority to DE1915243X, on 9 April 1932 application filed, in 20 June 1933 publication of US1915243A.

Rosing, Boris L'vovich Rosing (Борис Львович Розинг). 1907. Method for the electrical transmission of images over a distance, electronic television system with a Braun's cathode ray tube (Способ электрической передачи изображений на расстоянии), Russian patent no. 18,076, filed 25 July 1907, issued 30 October 1910, German (Deutsches Reich) Patent no. 209,320 filed 26 November 1907, issued 24 April 1909 as Verfahren zur elektrischen Fernübertragung von Bildern (Method for the electrical transmission of images); British patent no. 27570/1907 filed 13 December 1907, issued-granted 25 June 1908 as New or improved method of electrically transmitting to a distance real optical images and apparatus therefor; Art of electric telescoping U.S. Patent no. 1,161,734 filed 5 April 1911, on 5 April 1911 priority to US61916611A, issued-granted by publication on 23 November 1915. Similar: Electrical telescoping, U.S. Patent no. 1,135,624 filed 5 April 1911, issued 13 April 1915; British patent no. 5,486/1911 filed 4 March 1911.

Rüdenberg, Reinhold (for Siemens-Schuckert-Werken in Berlin). 1924. Oscillograph, German patents DBP 429926 and DE1695719X filled in in Germany on 20 December 1924, published in 1926. US application led by priority to DE1695719X filled by Serial No. 72,609 on 1 December 1925, Application granted by publication of US1695719A on 18 December 1928.

Rüdenberg, Reinhold (for Siemens-Schuckert-Werken in Berlin). 1931. Pictures by Electron Rays, German patent DBP 895635 filled 30 May 1931 published on 5 November 1953; DBP 916,838, filed 27 June 1931 published 19 August 1954.

Ruska, Ernst; Borries, Bodo von. 1932. Magnetic convergent lens of short field length (Concentration Coil, Magnetische Sammellinse kurzer Feldlänge), German patent DE 680284 filed March 16-17, 1932, granted 3 August 1939, published August 25, 1939.

Ruska, Ernst; Borries, Bodo von. 1932. Device to view and control optical images, German patent DE

679857, submitted March 17, 1932, published August 15, 1939.

Savery, Thomas. 1698. Machinery for raising water, giving motion to mills (A new invention for raising of water and occasioning motion to all sorts of mill work by the impellent force of fire, Miner's Friend), filled 2 July 1698, granted on 25 July 1698 for England and Wales under No. 356.

Sawyer, William Edward (of New York); Man, Albon (of Brooklyn). 1878. Improvement in electric lamps (Nitrogen atmosphere bulb with charcoal filament), US 205,144 patent application filed May 16, 1878, on 18 June 1878 application granted by publication of US205144A.

Schröter Fritz Georg Ernst (for by Telefunken AG, Gesellschaft für Drahtlose Telegraphie mbH). 1930. Methods of scanning television pictures (Verfahren zur Abtastung von Fernsehbildern, reproduction of "half-sized" images with the successive alternation of even and odd rows), application filed on 27 September 1930, 27 September 1930 priority to DE574085T, 8 April 1933 publication of DE574085C.

Shockley, William Bradford (for Nokia Bell Labs). 1948. Semiconductor amplifier (Transistor), application of Serial No. 35,423 filed June 26, 1948, Application filed on September 24, 1948 by priority to US50897A and US50895A (both Shockley's semiconductor amplifiers), Publication of US2502488A on April 4, 1950. Reprinted in: January 1998. Semiconductor Amplifier patent. *Proc. IEEE*. 86/1: 34-36.

Shockley, William Bradford (for Nokia Bell Labs). 1949. Semiconductor translating device (manufacture of a pn-contact with ionic bombardment), Application filed with priority to US89969A on 27 April 1949, on 18 January 1954 publication of US2666814A.

Shockley, William Bradford (for Nokia Bell Labs). 1949. Semiconductor translating device (for implanting ions into semiconductors), filed May 28, 1949 as US Patent 2,672,528, granted March 16, 1954.

Shockley, William Bradford (for Nokia Bell Labs). 1954. Forming semiconductive devices by ionic bombardment, on 28 October 1954 application filed with priority to US465393A, on 2 April 1957 publication of US2787564A.

Shockley, William Bradford. 1956. Semiconductor shift register, filled on 25 April 1956, granted as US patent no. 2967952 on 10 January 1961.

Siemens, Werner von; Hefner-Alteneck, Friedrich Franz Heinrich Philipp von (for Siemens and Halske company). 1873. Differential lamp, British patent №. 2,006 on June 5, 1873, French patent 99828 on July 5, 1873, addition dated on June 21, 1878.

Siemens, Charles William sir (of Westminster, Middlesex, England). 1879. Improvements in apparatus for manufacturing and moulding glass furnaces (Regenerative electric metal melting furnace), Letters Patent for Great Britain No. 4,763 on 22 November 1879.

Simpson, William Speirs (of London). 1892. Apparatus for casting metals (frying pan instead of the melting furnace, which he placed together with the mold in his emptied receiver). US Application filed September 15, 1892 by Serial No. 445,992, Publication of US493047A March 7, 1893 based on patents obtained in England No. 13,298 on July 20, 1892; in France No. 209,991 on July 25, 1892; in Germany No. 13,702 on July 26, 1892; in Belgium No. 76,207 on 28 July 1892 & Useful Improved Apparatus for Ejecting the Casting of Metals in Vacuo, patented in Great Britain No. 13,298 dated July 20, 1892; in France No. 209,991 dated July 25, 1892; in Belgium No. 76,207 dated July 28, 1892, in Germany No. 13,702 dated July 26, 1892.

Slišković, Josip (for Kapsch & Sons in Vienna). 1927-1929. Polydyne four lamp radio (4-Lampen-Radiogerät).

Slišković, Josip (for Kapsch & Sons in Vienna). 1929. TV system in December 1929 as part of a talk at the International Radio Club (IRC), April 1930 presentation at the Physical Institute of the University of Vienna and at 1930 Viennese Autumn Fair.

Smakula, Olexander (for Carl Zeiss AG). 1935. Method for increasing the light transmission of optical parts by lowering the refractive exponent at the interfaces of these optical parts (vapor deposition of CaF₂), Patent DE 685767 published on 1 November 1935.

Spangler James M. (of Canton, Ohio). 1908. Carpet sweeper and cleaner (portable electric vacuum cleaner), on 14 September 1907 application filed as US39286307A, Publication of US889823 on June 2, 1908.

Staite, William Edwards; Greener, William. 1846. Carbon enclosed in airtight transparent vessels, British patent GB 11076 on February 4, 1846.

Starr, John Wellington; King, Edward Augustin (of Warwick street, Middlesex, acting in Starr's name). 1844, 1845. Invention of improvements in obtaining light by electricity (lamp filled by platinum propelled by Grove's cells). In Washington D.C. in 1844 Starr filed a "caveat" or claim that he was preparing to file for a patent for his lamp and generator, which granted his rights for one year. British government granted and sealed a patent no. 10,919 (in King's name) for Starr's incandescent light on November 4, 1845, enrolled on May 4, 1846 (*The Repertory of Patent Inventions*. London, volume 7 (January-June 1946): 335-338).

Starr, John Wellington; Sanders, John Milton (in Starr's name). 1845, 1846. Electro-magneto machine (Generator co-designed by Starr and Sanders). British government patent no. 11,188 on 30 April 1846, enrolled on 30th October 1846.

Strode, Thomas T. (of Mortonville in the county of Chester, Pennsylvania). 1860. Improvement in Adding Machines (for Numbers), publication of US30264A patent dated on October 2, 1860.

Swan, Joseph Wilson. 1864, 1865. Transfer process for making carbon prints, a permanent photographic process as carbon photographic process, British patent 503/1864. Improvements in the production of printed surfaces by photographic agency (Photo-Mezzotint Prints), British patent no. 1791 on 6 July 1865.

Swan, Joseph Wilson (of Newcastle-on-Tyne, England). 1860, 1879, Vacuum lamp with charcoal filament, British patents nos. 18 & 250, filled in 1879 granted in 1880.

Swan, Joseph Wilson (Newcastle-on-Tyne, England). 1879, 1880. Improvements in electric lamps, and in the materials employed in their construction (treating cotton to produce parchmentised thread, catalogued as as Electric Lighting by Incandescence). British Patent No. 4933 filed on January 2, 1878, granted on November 27, 1880, noted at Royal Institution of Great Britain's Weekly Evening Meeting on Friday, 10 March 1882. US patent filled on 16 June 1880, application granted by publication of US234345A on 9 November 1880.

Swaty, Franz. June 1879. Procedure for production of hones, grinding tools and wheels in mineral bond (mineral bonded abrasives), using his own process patented in Vienna.

Swaty, Franz. 1903. The self sharpening/refacing hone with the glimmer particles (Alumin-Abziehstein, Alumina Razor Hones), registered by the Austrian Patent Office in 1903.

Swaty, Franz (from Maribor (Marburg)). 1911. "Grizzlith" Horns and grinding stones. US Patent Office. Ser. No. 53,892 (Class 4. Abrasive Detergent and polishing materials). Filed on 14 January 1911, granted-published on 14 March 1911. Claimed use since 18 October 1909. (*Official gazette of the United States Patent Office* volume 164 (March 1911): p. 498; *Official gazette of the United States Patent Office* volume 170 (12 September 1911): p. 489).

Swaty, Franziska remarried Bayer (doing business as widow of Franz Swaty in Maribor, Yugoslavia by claiming use since June 1879). 1925. Abrasive detergent and polishing materials, patent filed on 19 June 1925 under USA Ser. No. 216,662.

Swaty, Franziska remarried Bayer (doing business as widow of Franz Swaty in Maribor, Yugoslavia by claiming use since June 1879). 1926. Razor hones, grinding tools, sharpening stones, and sharpening wheels. Registered on January 16. 1906 by Franz

Swaty, Marburg, Austria-Hungary. Renewed on 16 January 1926 by Franziska Bayer Swaty under US no. 48808 (*Official gazette of the United States Patent Office* volume 348 (12 July 1926): 329; *Index of patents issued from the United States patent office* 1926, Washington: Government 1927, pp. 988, 1578-1579).

Szczepanik, Jan (Engineer); Kleinberg Ludwig (Banker, both of I Bartensteinstrasse 16, Vienna). 1897. Method and Apparatus for Reproducing Pictures and the like at a Distance by Means of Electricity (transmitting a picture by synchronously oscillating mirrors). British Patent No. 5031 applied on 24 February 1897, Complete Specification Left on 16 November 1897, Accepted on 24 February 1898.

Šlebinger, Vladimir (at Telecommunications and Telegraph Technology (Fernsprechtechnik und Telegraphentechnik) department of Heinrich-Hertz-Institut für Schwingungsforschung (Institute for Oscillation Research, HHI) at Franklinstrasse 1 Berlin-Charlottenburg established on 23 February 1928). 1932. Synchronisation des Bildes im Empfänger (synchronization of the image in the receiver), applied for German patent (Deutsches Reichspatent); Lichtmodulation des Kathodenstrahls (light modulation of the cathode ray), applied for German patent (Deutsches Reichspatent). Patents were never granted-published as they are not noted in *Patentblatt Bekanntmachungen auf Grund des Patentgesetzes und des Gesetzes betreffend den Schutz von Gebrauchsmustern Herausgegeben vom Reichspatentamt* in Berlin in 1932 (volume 56) or in any other volumes of that *Patentblatt*.

Taussig, Eduard de (Bahrenfeld, now the western quarter of the city of Hamburg in Holstein in Germany). 1889, 1893. Darstellung der Metalle mittels Elektrizität, German Patent No. 52 650 in 1893. Addition with the same title by German patent no. 72129 on 10 February 1893. Equipment for melting and casting, as well as for the representation of metals, both from their ores and from metal-containing slags, in air-diluted space with the help of electricity (electric furnace with a mold in a emptied receiver, improved process of smelting and casting, its leading feature being that the operations are carried on in a partial vacuum, Einrichtung zum

Schmelzen und Giessen, sowie zur Darstellung von Metallen, sowohl aus ihren Erzen, als auch aus metallhaltigen Schlacken, im luftverdünnten Raum und mit Hülfe der Elektrizität), Applied for German Patent on 7 February 1893, Published on 15 September 1893 as No. 18930207. Additional English patent in 1893. Italian patent: Processo per fondare e calore i metalli in una capacità ad aria rarefatta 53: 259 on 17 April 1890 and Processo per pulire metalli... 66: 135 on 6 April 1893 (*Gazzetta ufficiale del regno d'Italia*, Roma, 17 December 1894. no. 302, pages 6354, 6366).

Tesla, Nikola (of New York); Peck, Charles Fletcher (of Englewood, New Jersey, assigned one-half). 1887, 1888. Electro-magnetic motor (electric motor on alternating current), on 12 October 1887 application filed with priority to US1887252132, Application granted by Publication of US381968A on 1 May 1888 (on the same day under the same title he also patented US381969A, System of Electrical Distribution as US381970A, etc.).

Tesla, Nikola. 1891. Electric Incandescent Lamp, Application granted by Publication of US455069A on June 30, 1891.

Tesla, Nikola. 1899. Method of intensifying and utilizing effects transmitted through natural media (transmitting signals or intelligence from sending to a distant receiving station by current diffused through the earth), Application filed for Priority to US6231599A on June 24, 1899, on 5 November 1901 application granted by publication of US685953A.

Tholander, Henrik Evald (Thålander at Forsbacka Jernverks (Ironworks) in Sweden while he was employed as cabin engineer and metallurgist in 1875-1892 at 65 km distant Avesta Jernverks AB). 1881. Eliminated gases from the molten steel contained in a converter or pouring ladle by reducing the pressure, as in the case of other fluids, the gases released at a higher pressure escape from the molten steel when the air begins to get thinner, German patent no. 16479 granted on 30 June 1881.

Thurman, John S. (of St. Louis, Missouri), 1898, 1899. Pneumatic carpet-renovator (first motorized vacuum cleaner), Application filed with priority to

US69645898A on 14 November 1898, application granted by publication of US634042A on October 3, 1899.

Trump, John George; Cloud, Robert William (both for High Voltage Engineering Corporation (HVEC) Burlington, Massachusetts established by Trump and Van de Graaff). 1957. High-vacuum pumps for high-voltage acceleration tubes, application filed with priority to US666150A on 17 June 1957, on 16 February 1960 application granted with publication of US2925504A.

Valvasor, Janez Vajkard. 1687, 1692. Method of casting Statues in Metal; together with an Invention of his for making such cast statues of an extraordinary thinness, beyond any thing hitherto known or practised, published in *Phil. Trans.* and in *Actorum Eruditorum*.

Velde, Ties Siebolt Te (Tics Siebalt of Emmasingel in Eindhoven; Koelmans, Hein (both for Philips Research Laboratories (Laboratoria N.V. Philips' Gloeilampenfabrieken) filed by Philips Corporation in New York). 1966. Method of manufacturing a semiconductor device, application US630026A, on 14 April 1966 priority to NL666604963A, 11 April 1967 application filed in US, 2 December 1969 publication of US3481030A.

Vesel, Alenka; Mozetič, Miran; Ogrinc, Nives; Fras Zemljič, Lidija; Kraševac Glaser, Tjaša. 31 May 2019. Film and production method: UK patent application GB 1907793.2. London: Intellectual Property Office.

Wainwright, Jacob Tripler (Chicago civil engineer). 1898, 1899. Machine for exhausting molten metal at high temperature (improvement of Aitken's method), specification forming part of Reissued Letters of US Patent No. 11,737, dated April 25, 1899 (Original No. 598,031, dated January 25, 1898). Reissue No. 11,671, dated June 21, 1898, Application for new reissue filed November 14, 1898 by US serial No. 696,471 (*Official gazette of the United States Patent Office* (25 April 1899) Volume 87: 683). Patented in United Kingdom on 28 January 1898.

Waldron, Frederic Barnes (of Eccleston Park, Prescott, England). 1949. Manufacture of steel (A method of extracting gases that are occluded in molten steel which comprises continuously flowing such molten steel into the bottom of an enlarged chamber which is maintained under vacuum, continuously and unrestrictedly flowing the molten steel through said chamber while it rises therein to a substantial height due to the vacuum in said chamber whereby the occluded gases are separated from the steel and are withdrawn from said chamber by a gas extraction appliance and with drawing the degasified steel from a point at the bottom of said chamber into a chamber at atmosphere), Priority to GB2587793X on 5 April 1949, Application US105516A filed on 19 July 1949, on 4 March 1952 application granted by publication of US2587793A.

Wieghorst, Wilhelm Anton Friedrich (of the firm Wilhelm Anton Friedrich Wieghorst and Comp. in Hamburg). 1882. Baking-Oven (Steam furnaces, Einrichtung eines Röhrenbackofens mit Wasserheizung) Patented in London on March 1, 1882 (on 7 March 1882 according to *The Commissioners of Patents' journal*, volume 37); patent no. 61739 in Belgium on 18 June 1883; USA patent filed on 2 October 1883 granted by US302457 (*Official gazette of the United States Patent Office* 22 July 1884, 28: p. 346).

Williams Clyde E. (of Columbus, Ohio). 1931. Method of purifying metals (lifting a metal in a molten state upwardly through a tube by the introduction of substance in vapor phase under pressure into the metal in tube), US Application filed by Priority to US524583A (Serial No. 524,583) on March 23, 1931, Application granted by publication of US1921060A on 8 August 1933.

Zalar, Anton; Podgornik, Bogdan. 1984. Patentna prijava, Postopek za določanje globinske sestave vzorca, P 1697/84, IEVT, Ljubljana (Patent application, Procedure for determining the depth composition of a sample, Slovenian patent P 1697/84, IEVT, Ljubljana). Anton Zalar applied only for a Slovenian patent on sample rotation during AES analysis of thin films as he reported in Zalar, 2007 page 13. It appears that IEVT institute was reluctant to pay international patent fees at the time. The "Zalar Rotation" system or method and

mechanism is still extremely relevant today. In the US company Physical Electronics, it is still referred to under this name, while all other companies that use it on their instruments call this method only "sample rotation". The "Zalar Rotation" method and mechanism is still extremely relevant today for precise characterization of thin films in particularly in microelectronics. In the US company Physical Electronics producing the surface analytical equipment, it is still referred to under this name, while all other companies that use it on their analytical instruments call this method only "sample rotation". Zalar rotation system was not internationally patented, but Slovenian trademark protection was obtained. Zalar rotation (Zalar, 1985, 223) is a very significant refinement of the method of investigation of thin-layer structures, which significantly improved the depth resolution in the nanometric region and enabled the investigation of chemical reactions and diffusion at the interfaces internal phase boundaries of multilayer structures.

Zaplotnik, Rok; Mozetič, Miran; Primc, Gregor; Vesel, Alenka; Hori, Masaru; Osamu, Oda. 2019. Method and apparatus for deposition of carbon nanostructures: patent application PCT/EP2019/084734. London: Intellectual Property Office.

Zöller (Zoeller), Alfred (from Charlottenburg by Berlin). 1913. Hohle Glasscheibe (Hollow pane of glass, of various shapes, including corrugated glass plates containing separate discharged volumes), German patent application filed with priority to DEZ13429D on 29 October 1913, Application granted by Publication of DE387655C on 2 January 1924.

Zöller (Zoeller), Alfred (from Charlottenburg by Berlin). 1915. Electric Lamp, German Patent filed on 1 November 1913 and granted in 1915. The USA application filled on November 10, 1916 under Serial No. 130,074, granted under the provisions of the act on 3 March 1921 (*Official gazette of the United States Patent Office* (20 July 1926) volume 348: p. 707).

Zworykin, Vladimir Kosma (for CBS Corp. and Westinghouse Electric and Manufacturing Co.). 1925-1927. Television system, Application filed by

Priority to US43219A on 13 July 1925, application granted by publication of US1691324A on 13 November 1928. Similar: Improvements in or relating to television systems (fluorescent calcium tungstate for blue light of color television, an insulating layer of alumina or magnesia), Application filed-registered on July 3, 1926 under no. 16,736/26, granted by publication of GB255057A on 31 March 1927.

Zworykin, Vladimir Kosma (for Westinghouse Electric and Manufacturing Co.). 1923. Television system, application filed by priority to US683337A on December 29, 1923, Priority claimed from US376117A on 5 July 1929, Priority claimed from US57648531 on 21 November 1931, first worldwide litigation filed on 6 October 1938, application granted by publication of US2141059A on December 20, 1938.

Zworykin, Vladimir Kosma (of Swissvale, Pa., for Westinghouse Electric and Manufacturing Co.). 1929. Vacuum tube (kinescope), Filed November 16, 1929, issued in the United States under no. 2109245 on February 22, 1938.

Zworykin, Vladimir Kosma (of Haddonfield, N. J., for RCA Corp.). 1931. Method of and apparatus for producing images of objects (iconoscope), application filed by priority to US574772A on 13 November 1931, application granted by publication of US2021907A on 26 November 1935.

37.5 Journals & Periodicals

Acta Eruditorum = *Actorum Eruditorum*, published from 1682 to 1782 in Leipzig.

Almanacco provinciale della Dalmazia per l' anno 1819. Zara: Stamperia Governiale. Published in 1817-1848.

Am. J. Roentgenol. = *American Journal of Roentgenology and Radium Therapy*. New York City: The Societies American Roentgen Ray Society & American Radium Society published in 1922-1951, later renamed to *Am J Roentgenol Radium Ther Nucl Med* = *The American Journal of Roentgenology Radium Therapy and Nuclear Medicine*. In 1976 renamed back to *American Journal of Roentgenology*.

Ann.Chim. = *Annales de chimie et de physique*. Paris.

Ann. Phys. (Annals of physics) = Edited by Ludwig Wilhelm Gilbert under the titles *Annalen der Physik* and *Annalen der Physik und der physikalischen Chemie* in 1799–1824. *Annalen der Physik und Chemie* of Leipzig or while edited by Johann Christian Poggendorff (* 1796; † 1877) in 1824–1876 and by Gustav Heinrich Wiedemann in 1877–1899. Also called *Pogg. Ann.* or *Wied. Ann* subsequently. Under the editorship of Paul Karl Ludwig Drude *Annalen der Physik* in 1900–1906.

Annual report of the Commissioner of Patents for the year... Washington: United States congressional serial set, Senate document (also reprinted in *Scientific American*).

Archeografo Triestino Raccolta di Memorie, Notizie e Documenti Particolarmente per Servire Alla Storia di Trieste, del Friuli e dell'Istria = published by Società di Minerva in Trieste from 1829. In 1890 edited by Domenico Rossetti, Società di Minerva, Deputazione di storia patria per le Venezie. Sezione di Trieste.

Archiv. Math. = *AM* = *Archiv der Mathematik und Physik mit besonderer Rücksicht auf die Bedürfnisse der Lehrer an höheren Unterrichtsanstalten* (also:

Grunerts Archiv, Gruner's Archiv) scientific journal established by Johann August Grunert in 1841, published until 1920. It replaced *Mathematical Archives; Archiv für die gestammte Mathematik* (*Mathematisches Wörterbuch; oder Erklärung der Begriffe, Lehrsätze, Aufgaben und Methoden der Mathematik mit den nöthigen beweisen und literarischen nachrichten Begleitet in alphabetische Ordnung.* (ed. Klügel, Mollweide, Grunert. Leipzig: E. B. Schwicker) which published 5 volumes in years 1803-1831.

Berlin.Ber. = *Sitzungsberichte der Königlich Preussischen Akademie der Wissenschaften zu Berlin* (sessions of Prussian Academy of Sciences).

Beschreibung der Erfindungen und Verbesserungen, für welche in den kaiserlich-österreichischen Staaten Patente ertheilt wurden, und deren Privilegiums-Dauer nun erloschen ist... welcher die Privilegien vom Jahre 1821-1835 enthält. Wien: Kaiserl. Königl. Hof- und Staats-Aerarial-Druckerei, Volume 1 published in 1841. Volumes 1-5 published in 1841-1847.

Bollettino della Società Adriatica di Scienze Naturali in Trieste = Acts of society whose member of board was N. Vlacovich under the presidency of the botanist knight Muzio de Tornmasini.

Brit. J. Appl. Phys. = *British Journal of Applied Physics*.

Bull. de la Soc. Philomath. = *Bulletin de la Société Philomathique de Paris*, published in Paris in 1791-1948.

Caffè: o sia, Brevi e varj discorsi già distribuiti in fogli periodici Venezia: Appresso Pietro Pizzolato, edited in Milano in Milan from June 1764 until May 1766 by the counts Pietro Verri & Alessandro Verri and the marchese di Cesare Beccaria for their Società dei Pugni (Accademia dei Pugni) established in 1761 in Milano.

Carl's Rep. = *Carl, Philipp Franz Heinrich (ed) Repertorium für Experimental-Physik, für physikalische Technik, mathematische & astronomische Instrumentenkunde.*

Catalogus = *Catalogus Personarum & officiorum Provinciae austriacae Societatis Jesu Pro Anno....*
Vienna: Societas Jesu of Österreichische Provinz.
Last published edition of Old Jesuit Society printed in 1773.

Chemical News = The Chemical news and journal of industrial science; with which is incorporated the "Chemical gazette." A journal of practical chemistry in all its applications to pharmacy, arts and manufactures. London: Davey (ed. Crookes, William, Chemical news Office), published in 1859-1932.

The Commissioners of Patents' journal, started publishing in 1854 by London: The Office of The Commissioners of Patents, printed by George Edward Eyre and William Spottiswoode.

CR = C.R. = *Comptes Rendus Hebdomadaires des Séances de l'Académie des Sciences*, Paris: Bachelier.

Časopis pro pěstování matematiky a fyziky in Prague published since 1872 by the Union of Czechoslovak Mathematicians and Physicists (*Jednota českých matematiků*). In 1951 changed title to *Časopis pro pěstování matematiky*.

Dassenbacher, Johann E. (ed.). 1868. *Schematismus der Mittelschulen der im Reichsrat vertretenen Länder und der Militärgrenze II*. Znaim: self-publishing (Selbstverlage) (SSMULJ-12134). Continuations: *III Jahrgang* 1869. Wien: Selbstverlage (SSMULJ-47514; NMLJ-33472). 1872. *Schematismus der Mittelschulen der im Reichsrat vertretenen Länder und der Militärgrenze / 5. Jahrgang, Jahrbuch der Unterrichts-Anstalten der im Reichsrat vertretenen Königreiche und Länder*. Mährische Neustadt (Uničov by Olomouc): self-publishing; 1882. *Schematismus der österreichischen Mittelschulen (Mittelschulen) und der Fachschulen gleichen Ranges: vierzehnter Jahrgang 1881/1882: nebst Status... / nach amtlichen Quellen zusammengestellt von Joh. E. Dassenbacher*. Wien: Carl Frömmel, 1882 (SSMULJ). Dassenbacher's *Schematismus* were published in 1868-1882.

Deutscher Reichsanzeiger und Preußischer Staatsanzeiger. Printed by Berlin: Kessel, published from 1st volume on 4 May 1871 until 145th volume in April 1945.

Deutsche Wacht = Deutsche Wacht (German Guard, Nemška straža) was published weekly on Saturdays by Vereinsbuchdruckerei Celeja in German Language in Celje from 1883 to 1919. It was renamed from *Cillier Zeitung (Celje Journal)* and it was again renamed the *Cillier Zeitung* in 1929.

Diarium = Diaries of Ministers of the Jesuit College in Ljubljana. SI_AS 1073.

Dinglers Polytechnischen Journal = in 1820 established and edited by Augsburg manufacturer Johann Gottfried Dingler, soon coedited by his son Emil Maximilian Dingler.

Domovina (Celje) = Domovina (Homeland) edited by its owner Dragotin Hribar from 5 May 1892, later in that year replaced by newly established consortium of the Narodna tiskarna (National Printing). The management of the editorial board was taken over by the then lawyer candidate dr. Vekoslav Kukovec, later leader of the Styrian Liberals of National Party.

Electrical Review (New York) = Weekly published in 1882-1922 by Delano & Co. in 1883-1891, later by Electrical Review Pub. Co. as *Illustrated electrical review: a journal of scientific and electrical progress* in 1891-1897. Other titles used were: *Review of the telegraph and telephone; Electrical review and western electrician; Electrical review and industrial engineer*.

The Engineer, London: Office for Publication and Advertisement.

Ephemerides Astronomicae = Ephemerides astronomicae ad Meridianum Vindobonensem jussu Augustorum calculis definitae a M. Hell. Vienna: Trattner, edited by Hell, Maximilian in 1757-1793 and Franc de Paula Triesnecker until 1806.

Fernsehen = Allgemeiner Deutscher Fernsehverein was founded on September 13, 1929 and began to issue *Fernsehen* magazine in August of the

following year in Berlin by the publishing company of R. Reckendorf. The journal *Fernsehen Zeitschrift für Technik und Kultur des Fernsehwesens und des Tonfilms* was published in Berlin in 1930-1942, already in 1934 by Weidmann publishing house. Fritz Banneitz was editor in 1932, already in 1934-1936 joined by Paul Gehne and Gustav Engelbert Leithäuser.

Fowler, George. 1838-1839, *Fowler's Paisley Commercial Directory for 1838-1839: containing an alphabetical list of the merchants, traders, manufacturers, and principal inhabitants; also a copious street guide of Paisley, and an appendix containing useful lists and tables*. Paisley (Scotland): George Fowler, Ninth publication.

Fremden Blatt = Monatschrift published in Vienna but also in Habsburgian Milano and Nice.

Gazzetta ufficiale del regno d'Italia, Roma = official newspaper where texts of the laws and decrees of the Kingdom of Italy were officially disclosed from January 4, 1860 to June 18, 1946.

Gazzetta (ufficiale) di Zara, 1835. Zadar (Zara): Giovanni Demarchi. Published in 1832-1850.

Giornale d'Italia spettante alla scienza Naturale e principalmente all'Agricoltura, alle arti ed al Commercio. Venice: printed by Benedetto Milocco, edited by Francesco Grisellini 1765-1776 (former owner the Ljubljana based Society for agriculture and useful arts (Družba za kmetijstvo in uporabne umetnosti) now NUK-5341).

Giornale de' letterati D'Italia Venezia: Giovanni Gabbriello Ertz (Hertz). Founded in 1710 by Apostolo Zeno, Scipione Maffei, and Antonio Vallisneri. Edited by Zeno, Apostolo after 1718 by his brother Zeno, Pietro Caterino. Published until 1740.

Glas Naroda = The People's Voice was a Slovenian workers' paper in the United States, published in New York from 1893 to 1963.

Glas Naroda = unrelated to above, published by Josip Knaflič, editors Ante Gaber, Milan Zadnek,

Ivan Albreht, Josip Knaflič et all, printed by Ljubljana based Narodna prosveta in 1935-1936.

Grazer Geschäfts- und Adreß-Kalender für das Jahr... Graz: Selbstverlag der Buchdruckerei Gutenberg.

Historia Annua = Yearbook of Ljubljana Jesuits in three parts 1596-1773 where the middle part covering the years 1692-1721 was lost after WW1: SI_AS 1073. Collection of manuscripts. 180 r: Historia annua Collegii Societatis Jesu Labacensis (1596-1691). Published in: Baraga, France (ed.). 2002. Historia annua Collegii Societatis Jesu Labacensis (1596-1691). Ljubljana: Družina (Family) and in: Baraga, France (ed.). 2003. *Letopis Ljubljanskega kolegija Družbe Jezusove (Yearbook of Ljubljana college Society Of Jesus) (1596-1691)*. Ljubljana: Družina (Family). Historia Annua Collegii Labacensis anni 1722-1773. NUK. 5/53; Annua Collegii Labacensis 1722-1773. NUK. Ms 1544.

Hof- und Staats- Schematismus der römisch kaiserlichen auch kaiserlich-königlichen und erzherzoglichen Haupt- und Residenz-Stadt Wien: (derer daselbst befindlichen höchsten und hohen unmittelbaren Hofstellen, Chargen und Würden, niederen Kollegien Instanzen und Expeditionen) für das Jahr... (1776/1779-1804/1897). Wien: Joseph Gerold.

Hof- und Staatsschematismus (Staats-Schematismus) des Österreichischen Kaiserthums. 1807-1843. Wien. Continued as: *Hof- und Staats-Handbuch des Kaiserthumes Österreich (Hof- und Staatshandbuch des Österreichischen Kaiserthums)*. 1844-1868. Wien. Continued as: 1874-1918. *Hof- und Staats-Handbuch des Österreichisch-ungarischen Monarchie für das Jahr...: nach amtlichen Quellen zusammengestellt*, Wien: Druck und Verlag der k. k. Hof- und Staatsdruckerei.

HSPS = *Historical studies in the physical sciences*, University of California Press in Berkeley. The first editor Russell McCormach published ten volumes under that name in 1969-1979, later edited by John Heilbron who added "biology" to the title, now *Historical studies in the Natural sciences* edited by Cathryn Leigh Carson in 2008-2013.

(Subject-matter) Index of patents issued from the United States patent office, Washington: Government, published annually after 1874.

Instanz Schematismus für das Herzogthum Krain: ... Laibach (Ljubljana): Gedruckt bei Ignaz Merk, 1796–1803.

Instanzen Schematismus vom Herzogthume Krain, dann der gefürsteten Grafschaften Goerz und Gradiska : für das Jahr ... Laibach (Ljubljana): Gedruckt den Leopold Eger, 1804–1806.

IRE Trans. Electron Devices = IRE Transactions on Electron Devices.

La provincia dell'Istria: organo ufficiale per gli atti della Società agraria istriana. Koper (Capodistria): Giuseppe Tondelli (later B. Appolonio & Caprin, finally Carlo Priora). Published from 1 September 1867 until 1903. Edited alternatively by Nicolo de Madonizza and Anteo Gravisi. In 1867-1894 published as *La Provincia dell'Istria = La provincia: giornale degli interessi civili, economici ed amministrativi dell'Istria*. Koper (Capodistria): G. Tondelli.

Journal de Physique, de chimie, d'histoire naturelle et des arts. Initially: *Observations sur la Physique, sur l'histoire naturell et sur les arts (de chimie, d'histoire naturelle et des arts), avec des blanches en taille douce dédiées a Mgr le Comte d'Artois; Par M. L'Abbé Rozier, de plusieurs Académies, & par M. J. A. Mongez le Jeune, Chanon Régulier de Sainte-Genevieve, des Académies Royales des Sciences de Rouen, de Dion, de Lyon, &c, &c.* (ed. Jean François Pilâtre de Rozier & Jean-André Mongez, later also Jean-Claude de La Métherie & Henri-Marie Ducrotay de Blainville). Paris: Ruault / Paris: Au Bureau du Journal de physique, rue & Hôtel de Serpente / Paris: Bachelier.

J. Am. Chem. Soc. = Journal of the American Chemical Society.

J. Vac. Sci. Technol. A = Journal of Vacuum Science & Technology A: Vacuum, Surfaces, and Films. New York: Published for the Society by the American Institute of Physics after 1983.

Journal littéraire de la Haye printed in The Hague by Thomas Johnson and edited by French Huguenot refugee Prosper Marchand in 1713-1723.

Kayserlicher Und Königlicher Wie auch Ertz-Herzoglichen Und Dero Residenz-Stadt Wien Staats- und Stands-Calender. Wien: Joseph Gerold, 1790-1804.

Kayserlicher Und Königlicher Wie auch Ertzhertzoglicher Dann Dero Haupt- und Residentz-Stadt Wien Staats- und Standes-Calender, Auf das Gnaden-reiche Jahr ... Mit einem Schematismo gezieret. Cum privilegio Caesareo speciali. 1843, 1844. Wien: Johann Baptist Schönwetter. In 1735-1767 printed by Leopold Johann Kaliwoda in Vienna.

Královská česká společnost nauk (KŠSN, Societas Scientiarum Bohemica; Königliche böhmische Gesellschaft der Wissenschaften). 1791 – 1799. *Kaiserlich Königlicher Schematismus für das Königreich Böhmen auf das Jahr...* Prague: Jan Nepomuk Ferdinand Schönfeld. Continued in 1801-1903 as printed in Prague by Haase.

Kras = Kras: revija o Krasu in krasu, o ljudeh in njihovem ustvarjanju, edited by Ida Vodopivec-Rebilj, her husband Dušan Rebolj and their sons Lev & Aljoša, printed by Komen: Mediacarso in 1994-2013.

Kundschaftsblatt = Wöchentliches Kundschaftsblatt des Herzogthums Krain. Ljubljana: Janez Friderik Eger, volume 1 (1775), volume 2 (1776), published by Carniolan Society for Agriculture and Useful Arts, edited by B. Hacquet or by G. Schöttl, or by both as they never signed themselves.

Lehmann, Adolph. 1859-1922. *Adolph Lehmann's allgemeiner Wohnungs-Anzeiger nebst Handels- u. Gewerbe-Adressbuch für d. k.k. Reichshaupt- u. Residenzstadt Wien u. Umgebung*. Wien: Hölder.

LZ = Ljubljanski Zvon (Ljubljana Bell journal). LZg = *Laibacher Zeitung (Ljubljana Daily)* (Ljubljana: Ignaz Alois Edler v. Kleinmayr). Its Official Gazette part: *Amtsblatt zur Laibacher Zeitung*. Its weekly supplement was *Laibacher Wochenblatt (Ljubljana Weekly)*.

The London Gazette = the most important among official journals in the United Kingdom first issued on November 7, 1665.

Marburger Zeitung = first printed Maribor newspaper edited by Maribor (Marburg) German minority in 1862-1945, issued two or three times per week until 1919 and later as a daily.

Mechanics' Magazine, museum, register, journal, and gazette = Founded by the Scottish patent agent Joseph Clinton Robertson as its predominant editor in 1823, printed in London by M. Salomon & in 1829-1852 issued 47 volumes. Printed in London: Robertson, Brooman & Co. and edited by R.A. Brooman on July 3-December 25, 1851.

Militär-Schematismus des österreichischen Kaiserthumes. 1815-1868. Wien: Hof- und Staatsdruckerei. Later in 1870-1888 published as: *Kais. Königl. Militär-Schematismus für...* Wien: Staatsdruckerei. Later in 1889-1914 published as: *(Militär-) Schematismus für das kaiserliche und königliche Heer und für die kaiserliche und königliche Kriegsmarine (Kriegs-Marine) für...* Wien: Staatsdruckerei.

The Mining Journal, Railway and Commercial Gazette established in 1835, printed in London by Henry English in 1844-1908.

Mitt. nat. Ver. Steier. = *Mittheilungen des naturwissenschaftlichen Vereines für Steiermark*. Graz.

Narodne novine (Zagreb) = established by Ljudevit Gaj as *Novine Horvatzke* 1835, firstly renamed to *Narodne novine* (*The People's Newspaper*) in 1843.

Narodni list: glasilo Narodne stranke za Štajersko (Celje) = *The National Journal* was published weekly from October 24, 1906 to July 30, 1914 by the National Party for Styria edited by Andrej Sever and after few numbers by Vekoslav Špindler in 1906-1914.

La Nature = *La Nature. Revue des Sciences et de leurs applications aux arts et à l'industrie* (Paris), in 1873 founded by Gaston Tissandier, in 1972 absorbed by the journal *La Recherche*.

Nucl. Instrum. Methods. = *Nuclear Instruments and Methods in Physics Research*.

Obzornik mat. fiz. = *Obzornik za matematiko in fiziko* (Review of mathematics and physics), Ljubljana.

Odmevi: literarno-kulturna revija (*Echoes*) = Published quarterly in Ljubljana by Radivoj Peterlin-Petruška until second volume fourth number in 1929-1933.

Official gazette of the United States Patent Office. Washington: The Patent Office, 882 volumes published in 1872-1971.

Österreichisches Patentblatt. Teil 2, Patentanmeldungen published by Vienna: Lorenz from 1899 as yearly of the Austrian Patent Office (Österreichische Patentamt) which started its work in Vienna on January 1, 1899.

Pagine istriane established in 1902 and first printed in next year by Koper: Cobol & Priora, edited by Priora, Carlo, directed by Venturini, Domenico.

Patentblatt Bekanntmachungen auf Grund des Patentgesetzes und des Gesetzes betreffend den Schutz von Gebrauchslustern Herausgegeben vom Reichspatentamt, Berlin, published after the foundation of the Imperial Patent Office in 1877.

Phys. Bl. = *Physikalische Blätter* was the official journal of the *Deutsche Physikalische Gesellschaft*. It was founded in 1943 by Ernst Brüche, who was also the editor from 1944 to 1972. After December 2001 it was replaced by *Physik Journal*.

Phys. Rev. = *Physical Review* was established in 1893 published by the *American Physical Society* (APS). In July 1958, the sister journal *Physical Review Letters* was introduced to publish short articles of particularly broad interest, initially edited by George Lockwood Trigg, who remained as editor until 1988.

Phil. Trans. = *Philosophical Transactions of the RS*, during R. Hooke's Secretariat in 1677-1683 it was temporarily renamed *Philosophical Collections*.

Phys. Z. = Physikalische Zeitschrift (Physical Journal) published from 1899 to 1945 by S. Hirzel Verlag in Leipzig.

Pogg. Ann. = see *Ann. Phys.*

Pressburger Zeitung = published in Bratislava (Pressburg, Preßburg) twice a week from 1764 and daily from 1848 to 1929.

Primorski slovenski biografski leksikon edited by Martin Jevnikar and published by Gorica: Goriška Mohorjeva družba in 1974-1994.

Proc. IEEE = The Institute of Electrical and Electronics Engineers, Inc. USA = IEEE proceedings.

Rad (Work) = Rad Jugoslovenske akademije Znanosti (Work of Yugoslavian academy of Sciences), Zagreb.

Rang- und Einteilungsliste der k. u. k. Kriegsmarine = Austro-Hungarian Monarchy. Marine-Section. Wien: Staatsdruckerei. Published in 1907-1915.

The Repertory of Patent Inventions: and Other Discoveries and Improvements in Arts, Manufactures, and Agriculture; Being a Continuation, on an Enlarged Plan, of the Repertory of Arts & Manufactures, a work originally undertaken in the year 1794, and still carried on, with a view to collect, record, and bring into public notice, the useful inventions of all nations. 1784-1825-1862. London: T. and G. Underwood in 1827, London: J.S. Hodson in 1839, London: Alexander Macintosh in 1846.

RHS = Revue d'histoire des sciences, Paris.

Der Sammler ein Unterhaltungsblatt = Viennese journal printed by Anton Doll in Vienna (Wien) and published by Strauß in 1809-1846.

SBL = Slovenian Biographic Lexicon, published by Ljubljana: Zadružna gospodarska banka by and Ljubljana: SAZU in 1925-1991. Published anew under the direction of Barbara Šterbenc Svetina and her boss Oto Luthar printed by Ljubljana: ZRC

SAZU as New Slovenian Biographic Lexicon (Novi Slovenski Biografski Leksikon), began in 2013.

Schematismus für das Herzogthum Krain: ... : mit verschiedenen nützlichen Nachrichten geographischen, und statistischen Inhalts. 1794, 1795, 1796. Laibach: by Ignaz Merk, in 1798-1799 by Anton Degotardi; later by Leopold Eger.

Schematismus für Krain und Görz auf das Jahr ... 1808–1809. Ljubljana: Leopold Eger. Previously Eger printed *Instanzen Schematismus vom Herzogthume Krain, dann der gefürsteten Grafschaften Goerz und Gradiska: für das Jahr 1804-1806.*

Schriften des Vereines zur Verbreitung naturwissenschaftlicher Kenntnisse in Wien = the journal of Verein zur Verbreitung Naturwissenschaftlicher Kenntnisse Established in Vienna by efforts of Josef Grailich in 1855-15 January 1860 with Albert Salomon Anselm baron Rothschild among its members in 1873.

Slovenec = Slovenec: političen list za slovenski narod, Ljubljana: Ljudska tiskarna, published in 1873-1945, after 1883 as a daily of the local Clerical party.

Slovenski dom = Ljubljana based daily first printed in 1935. After the occupation in April 1941 official edition of Fascist authorities until May 1946. Initially edited by Jože Košiček, issued-published by Ivan Rakovec, printed by Jugoslovska tiskarna in Ljubljana represented by K. Čeč.

Slovenski gospodar = Maribor based Catholic conservative magazine published from 1867 to 1941, initially edited by Matija Prelog, published by Katoliško tiskovno društvo (Catholic Printing Society) from 1871 to 1921.

Slovenski Narod = initially published triweekly in Maribor, after 1872 in Ljubljana, from 1 January 1873 first Slovenian daily as an organ of Liberal party before WW1, printed in 1868–1943.

Slovenski Poročevalec = The Slovenian reporter began as an illegal newspaper of the Communist Party of Slovenia. Two issues were published in

1938, but it was not published until 1941. It was published periodically between 1941 and 1945 as *Slovenski poročevalec: glasilo Osvobodilne fronte*, and after 1945 it became a daily. In 1945, they confiscated two buildings, a printing house, all the equipment, the library of the editorial board of the newspaper *Jutro*. In 1953 it was edited by Sergej Vošnjak. In 1959, with the merger of *Slovenski poročevalec* and *Ljudska pravica*, the newspaper *Delo* was created.

Školski vjesnik: stručni list zemaljske vlade za Bosnu i Hercegovinu (Sarajevski školski vjesnik), edited by Dlustuš, Ljuboje. Printed in Sarajevo by the official Zemaljska štamparija. First volume published in January 1894. The last 16 volume numbers 11-12 printed in December 1909 as monthly of Bosnian government (Zemaljska vlada Bosne i Hercegovine).

Tagesbote für Untersteiermark Organ der liberalen Partei = Maribor daily of local liberal party published from 1871 to 1945.

Technische Blätter: Zeitschr. d. Deutschen Polytechnischen Vereins in Böhmen (Deutscher Polytechnischer Verein in Böhmen), volume 1 (1869) – volume 50 (1918).

Tentzel, Wilhelm Ernst. 1689–1698. *Monatliche Unterredungen einiger guten Freunde von allerhand Büchern und andern annemlichen Geschichten; allen Liebhabern der Curiositäten zur Ergetzlichkeit und Nachsinnen heraus gegeben von (Wilhelm Ernst Tentzel = A. B.)*, Thorn: Laurer / Leipzig: Gleditsch & Thomas Fritch. About Philipp Lohmeier in the issue of September 1697 on p. 766.

Vakuum-technik printed in Idstein/ Taunus/ Berlin by Rudolf A. Lang. Published by: Deutscher Arbeitskreis Vakuum, Deutsche Arbeitsgemeinschaft Vakuum, Österreichische Gesellschaft für Vakuumtechnik, and Schweizerische Gesellschaft für Vakuumphysik und Technik. Volume 1 printed in 1952, last volume 38 published in 1989.

Vaniček, Alois (ed.). 1859. *Schematismus der österreichischen Gymnasien und Realschulen für das Schuljahr 1858-1859. Herausgegeben von Alois Vaniček k.k. Gymnasiallehrer in Olmütz*. Olmütz: A.

Halauska. Continuation: 1860. *Schematismus der österreichischen Gymnasien und Realschulen für das Schuljahr 1859-60*. Prag: F. Tempsky (SSMULJ-12136).

Verhandlungen der kaiserlich-königlichen zoologisch – botanischen Gesellschaft in Wien = Wien: Zoologisch-Botanische Gesellschaft & W. Braumüller. 1852-1915. Later after 1918 just *Verhandlungen der Zoologisch-Botanischen Gesellschaft in Wien*.

Verordnungsblatt für den Dienstbereich des k.k. Ministeriums für Kultus und Unterricht. Jahrgang ... Wien: Staatsdruckerei = Yearbook of Habsburgian State Ministry of Religion and Education published in 1869-1918/1919.

Viet = Voprosy istorii estestvoznaniya i tekhniki (Institut istorii estestvoznaniya i tekhniki edited by Akademija nauk SSSR (*Вопросы истории естествознания и техники*, институт истории естествознания и техники. Академия наук СССР, *Studies in the History of Science and Technology*), established in 1980, now edited by Russian Academy of Science (Российская академия наук (РАН) & ИИЕТ РАН).

Wien. Anz. = Anzeiger der (Kaiserlichen) Österreichischen Akademie der Wissenschaften, Mathematisch-Naturwissenschaftliche Klasse.

Wien. Ber. = Wiener Sitzungsberichte der kaiserlichen Akademie der Wissenschaften in Wien (established in 1848).

Denkschriften der Kaiserlichen Akademie der Wissenschaften. Mathematisch-naturwissenschaftliche Klasse.

Wien. Klin. Wschr. = Wiener klinische Wochenschrift, the Central European Journal of Medicine established in Vienna by Gesellschaft der Ärzte in 1888.

Wiener Zeitung = Wienerisches Diarium in 1780 renamed to *Wiener Zeitung (Viennese newspaper)*.

Wochenversammlung des Architekten- und Ingenieur-Vereines in Böhmen. Paper read there at

weekly meetings (Vortrag gehalten in der Wochenversammlung) mostly published in *Technische Blätter (Zeitschrift des Deutschen Polytechnischen Vereins in Böhmen (Deutscher Polytechnischer Verein in Böhmen))*: *Vierteljahrschrift des Deutschen Ingenieur- und Architekten-Vereines in Böhmen (Zprávy spolku architektů a inženýrů)* in Prague in 1869-1919.

Wochenversammlung des österreichischen Architekten- und Ingenieurvereines (Ingenieur- und Architekten-Vereines, Zprávy spolku architektů a inženýrů, ÖIAV). Paper read there at weekly meetings (Vortrag gehalten in der Wochenversammlung) mostly published in *Zeitschrift des österreichischen Ingenieur- und Architekten-Vereines (1876-1891 called Wochenschrift des österreichischen Ingenieur- und Architekten-Vereines, later renamed to Österreichische Ingenieur- und Architekten-Zeitschrift, ÖIAZ)*. Volume 50 published in 1898.

Yearbooks (Yearly Journal, Izvestje, Izvešće, Izvješće, Izviešće o kralj. Velikoj gimnaziji u..., Programm, Programma, Jahrsberichte, Jahres-Bericht) of secondary schools = Published almost regularly in Habsburgian Monarchy and elsewhere in Central Europe for Grammar Schools, Real Schools and Trade Academia (Akademie) after 1848.

Zastava (Novi Sad) radical party's local newspaper (*Застава, Нови Сад*) editor Jakov Jasha Tomich (Јаков „Јаша” Томић).

Z. öst. Gym. = Zeit. f. österreich. gymn. = Zeitschrift für die österreichischen Gymnasien (mit Beilagen und Supplement, Zeitschrift fuer die Oesterreichischen Gymnasien). Wien: Gerold (initially Wien: C. Seidl). Established in 1850 by J.G. Seidl, Bonitz and J. Mozart. Volumes 1 to 69 published in 1850-1919/20. Index of volumes 1 (1850) to 40 (1889) published by Stejskal in 1891.

Zeitschrift für das Realschulwesen, Wien: A. Holder (established in 1876 by Kolbe, Hoffmann and Warhanek).

ZMF = Z.Math.Phys. = Zeitschrift für Mathematik und Physik, Organ für angewandte Mathematik.

Leipzig: B. G. Teubner, volume 1 appeared in 1856 edited by Oscar Schlömilch until 1896 with occasional assistance of Moritz Cantor, E. Kahl and others. The last volume 64 in 1917.

Z. Phys. = Zeitschrift für Physik (Journal for physics) established in 1920 by Springer Berlin Heidelberg and stopped publication in 1997, when it merged with other journals to form the new European Physical Journal series.

Zora = Zora časopis zabavi in poduku published in Maribor from 1872 to 1878, in last two years edited by Janko Pajk in his Maribor based Pajk's Narodna Tiskarna.

37.6 Index of Major Important Companies, Businesses, Institutions, Journals, Abbreviations and Lesser-Known Terms

AAAS = American Association for the Advancement of Science.

APUG = Archivio della Pontificia Università Gregoriana, Rome (numbers of film and pages).

AR = Académie Royale des Sciences, Paris.

ARRS = Slovenian Research Agency.

AS = Archives of the Republic of Slovenia in Ljubljana.

ATT = AT&T = The Bell Telephone Company founded by Alexander Graham Bell in 1877 became the American Telephone and Telegraph Company in 1885 and was later rebranded as AT&T Corporation.

AVS = American Vacuum Society.

BAAS = British Association for the Advancement of Science.

Balzers Gerätebau = Anstalt Balzers, Liechtenstein.

Bell Labs = Bell Telephone Laboratories, Murray Hill, New Jersey, USA.

Caltech = California Institute of Technology, Pasadena, California.

Cavendish = Cavendish Laboratory, Cambridge.

CCE = Compagnie Continentale Edison.

DVTS = Society for Vacuum Technology of Slovenia.

EELC = Edison Electric Light Company 125Extrion Extrion, Corp., today Varian SEA.

Fairchild = Fairchild Semiconductor Corporation, Mountain View, California.

FRS = Fellow of the Royal Society.

GE = General Electrics Co., Schenectady (Edison Company).

GEC = General Electric Company, Ltd. GEM General Electric Metallized GME General Micro-Electronics Inc., a subsidiary of Fairchild, founded in 1963.

Heraeus = WC Heraeus Vakuum-Schmelze GmbH in Hanau.

HVEC = High Voltage Engineering Company, USA.

IAEA = Mednarodna agencija za atomsko energijo s sedežem na Dunaju (International agency for atomic energy based in Vienna).

IEVT = Institute for Electronics and Vacuum Technique.

IJS = Institute » Jožef Stefan", Ljubljana.

IMT = Institute of Metals and Technology established in 1948 om Ljubljana to support steel industry; it became a public research institute in 1997.

Intel = Intel Corporation headquartered in Santa Clara, California.

IPC = Ion Physics Corporation, Burlington, Massachusetts, USA.

ITPO = Institute of Surface Technology and Optoelectronics, Ljubljana.

Leybold = in 1851 Leybold & Kothe in Köln, later E. Leybold's Nachfolger (E. Leybold's Successor), in 1967 Leybold Heraeus GmbH, in 1994 Balzers and Leybold Group as ALD Vacuum Technik GmbH (ALD Vacuum Technologies GmbH) with seat in Hanau, then Leybold AG, now Leybold (Vacuum) GmbH.

Mayr = Mayr's offer of books in Ljubljana in 1678 printed as *Catalogus Librorum qui Nundinis Labacensibus Autummalibus in Officina Libraria Joannis Baptistae Mayr.*

MIT = Massachusetts Institute of Technology.

NAS = National Academy of Sciences, USA.

NEK = Nuklearna elektrarna (Nuclear power Plant) Krško.

NUK = The reference codes at National and University Library of Ljubljana.

OFM = Friars Minors, Franciscans.

OP = Dominicans, Ordo Praedicatorum.

OSRAM Licht AG was founded by the merger of the lighting businesses of Auergesellschaft, Siemens & Halske and Allgemeine Elektrizitäts-Gesellschaft in Munich in 1919.

Philips = Philips Corporation, Eindhoven.

Rangaku = Japanese science based on Dutch works which prevailed in Japan after 1720 for a whole century.

RCA = Radio Corporation of America.

RI = Royal Institution, London.

RS = Royal Society with members (fellows) FRS, London.

S. EE = Société Électrique Edison, Paris.

Sematech = Sematech Inc., Austin, Texas.

Shockley Semiconductor Laboratories = Shockley Semiconductor Laboratory in Palo Alto, California, established in 1955, as subordinate to Beckman Instruments, Inc.

SJ = Societatis Jesu, Jesuits.

SM = Slovenian Queen Bee (Slovenska Matica).

SUZUP = Zvezna uprava za napredek proizvodnje (Yugoslav Federal Agency for the Advancements of Productions).

Temescal = Temescal Metallurgical Corporation in California.

TI = Texas Instruments, Inc., Dallas, Texas.

UELC = United Electric Lighting Company, London.

Varian = Vacuum Division of Varian Associates, Palo Alto, California; Varian Ion Implant Systems, Blackburn Industrial Park, Gloucester, Massachusetts.

WE = Western Electrics.

ZAL = Historical Archive, Ljubljana.

ZKNE – Zvezna komisija za nuklearno energijo (Yugoslav Federal Agency for Nuclear Energy).

ZRC SAZU (SRC SASA) = Scientific Research Centre of the Slovenian Academy of Sciences and Arts.

37.7 Index of Noted Important Persons Mentioned (their deaths are designated by † even for people with no Christian background)

A

Pietro D'Abano (* 1257; † 1316).

Ernst Abbe (* 1840; † 1905 Jena).

Max Abraham (* 1875 Gdansk; † 1922 Munich).

Henri Azariah Abraham (* 1868; † 1943 Oświęcim (Auschwitz) in south Poland).

Karl Acham (*1939 Leoben), the historian of science and sociologist.

Allessandro Achillini (* 1463; †1512).

José de Acosta (* 1540; SJ; † 1600).

Giuseppe Accurti (Joseph, * 11 August 1824 Senj; † September 11, 1907 Trieste).

Johann Adams senior (* 1709; † 1773 London).

Walter Sydney Adams (* 1876 Antakya in Turkey; † 1956 Pasadena)

Michel Adanson (* 1727 Aix-en-Provence; † 1806 Paris).

Friedrich Adler (Friedrich Wolfgang "Fritz", * 1879 Vienna; † 1960 Zurich).

Miroslav Adlešič (* 1907 Postojna; † 2002 Ljubljana).

Franz Maria Ulrich Theodosius Aepinus (* December 13, 1724 Rostock in Prussia; † August 10/22, 1802 Dorpath).

William Aglionby (* Summer 1641; † November 28, 1705).

Maria Gaetana Agnesi (* 1718; † 1799).

Georg Bauer Agricola (* 1494; † 1555),

Cornelius Henrich Agrippa (* 1486 Nettesheim; † 1535)

Nicolas-Joseph Sanchez baron d'Aguilar (* 1739; † 1822).

Johann Agyropolus (* 1415; † 1489).

August von Aigentler, married Šantel (* 1852; † 1934).

Henriette (Jetti) von Aigentler, married Boltzmann (* 1854; † 1936).

Franz Aigner (* May 13, 1882 St. Pölten, Lower Austria; † 19 July 1945 Vienna).

Emmanuel-Armand de Vignerot du Plessis-Richelieu, duc d'Aiguillon (* 1720; † 1788).

Georg Biddell Airy (* 1801; † 1892).

Russel Aitken, an engineer at No. 36, Great George street in Westminster county of Middlesex in England.

pharaoh Akhenaten (Echnaton, † 1334/35 BC).

Károly Akin (C.K., * 1830 Buda; † 1895 Rijeka (Fiume)).

Gajo Alaga (* 1924; † 1988).

Albert the Great (Albertus Magnus, * 1200; † 1280).

Al-Biruni (Abu Reihan Muhammed ibn Ahmad, Al-Bīrūnī, Al Biruni, * 973 Uzbekistan; † 1048 Ghazni in central Afghanistan).

Aldo Albònico (* 1947 Milano; † 1999 Milano?).

Herbert Otto Albrecht, worked in Berlin in 1928.

Thaddaeus Alderottus, Thaddée de Florence, Alderotti, * 1206/1215 Florence; † 1295).

Alexander Alekhine (Алекса́ндр Алекса́ндрович Алéхин, * 1892; † 1946).

Alexander VII (Fabio Chigi, Aleksander, * 1599; † 1667), the Pope between 1655–1667.

Jean Le Rond d'Alembert (* 1717; † 1783).

Zhores Ivanovič Alferov (Жорéс Ива́нович Алфёров, 1930 Vitebsk; † 2019 Saint Petersburg).

Hannes Olof Gösta Alfvén (* 1908; † 1995) 243

Francesco Algarotti (* 1712 Venezia; † 1764 Pisa)

Al-Biṭrūjī-Alpetragius (Abū Ishāq Nūr al-Dīn al-Biṭrūyī, Nur al-Din ibn Ishaq Al-Biṭrūjī, * Morocco; † around 1204/1205 Sevilla).

Ghiyāth al-Dīn Jamshīd Mas'ūd al-Kāshī (al-Kāshānī, * 1380; † 1429).

Moritz Allé (* 1837, Brno; † 1913).

James Van Allen (* 1914; † 2006).

Pierre Alexandre Joseph Allent (* 1772; † 1837 Paris).

Daniel Alpert (* 1917 Hartford, Conn.; † November 4, 2015 Eugene, Oregon).

Ala al-Dīn Ali ibn Muhammed al-Qushji (* 1403; † 1474).

Hilarius Altobello (Ilario Altobelli, * 1560 Montecchio (Treia) in Macerata; † 1637).

Émile Amagat (* 1841 Saint-Satur; † 1915 Saint-Satur).

Ubiratan D'Ambrosio (* 1932 São Paulo).

Anton Ambschell (* 1751 Győr; † 1821 Bratislava).

Joseph Sweetman Ames (* 1864 Manchester, Vermont in USA; † 1943 Baltimore, Maryland).

Jean-Joseph Maria Amiot (* 1718; SJ; † 1793).

Chrysostomus Amon (baptized Karl Anton. * 1819 Lilienfeld in Lower Austria south of St. Pölten; 1838 Cistercian at Lilienfeld Abbey; † 1889 Lilienfeld), professor of mathematics, physics from 1 September 1850 until 1872, after 1868 director of the Cistercian Neukloster Higher Grammar school at Wiener-Neustadt. From 1865 a correspondent for the Geological Institute and a member of the Austrian Society for Meteorology.

Slavko Amon (* 1945 Ljubljana).

Guillaume Amontons (* 1663; † 1705) 33

Eusebius Amort (* 15 November 1692 Bibermuehle in Bavaria; † 5 February 1775 Polling).

André Marie Ampère (André-Marie, * 1775; † 1836).

André Anders grew up in East Germany and studied physics in Wroclaw, Berlin, and Moscow until his Berliner POhD in 1987. He became a Senior Staff Scientist and the Leader of the Plasma Applications Group at Lawrence Berkeley National Laboratory, Berkeley, California. In 2017 he was appointed Director and CEO of the Leibniz Institute of Surface Engineering in Leipzig, and Professor of Applied Physics at the Felix Bloch Institute of Solid State Physics of the University of Leipzig.

David Leonard Anderson (* 1919 Portland, Oregon; † 1996 Oberlin, Ohio).

Joseph Chapman Anderson (Andy, * 1922; † 2001).

Leland I. Anderson (* October 12, 1928).

Philip Warren Anderson (* 1923 Indianapolis; † 2020 Princeton).

Edward Neville da Costa Andrade (* 1887 London; † 1971).

Rudolf Andrejka noble (plemeniti) Livnogradski (* 1880 Ljubljana; † 1948 Ljubljana).

Pasquale Andreoli (* 1777; † 1837).

Thomas Andrews (* 1813; † 1885).

Karl Andrian (Adrian, * 1680 Trident; † February 7, 1745 Graz).

Anton Andrian (* 1731 Gorizia; † 1761 Vienna).

Andronicus of Rhodes (Ἀνδρόνικος ὁ Ῥόδιος, flourished about 60 BC).

Anton Angerer (* 1720; † 1802 Linz).

bishop Vittorio Angius (* 1797 Calgiari; † 1862 Turin).

Anders Jonas Ångström (Angstrom, * 1814; † 1874 Uppsala).

George Frederick Ansell (* 1826; † 1880).

Imbra Antolić (Имбра Антолић, Mirko, * 1801 Nevinacby Bjelovar; † 1853 Petrinja).

Moriz Antolić (Мориц Антолић, Mavro, Moritz, Mavricij, Vid, * 1835 Rakovac; † 1870 suicide by poisoning in Rakovac-Karolvac).

Peter Apian (* 1495 Leising in Lower Saxony; † 1552)

Francesco Maria Appendini (* 1768 Poirino near Torino; † 1837 Zadar).

Urbano Appendini (* 1777 Poirino; Piarist; † 1834 Zadar).

Edward Victor Appleton (* 1892; † 1965) 159

Joseph Apponyi (* 1718; SJ 1736 Vienna; † 1757).

Dominique François Jean Arago (* 1786; † 1853) 240

Aratus Solensis (Ἄρατος ὁ Σολεύς, Árato de Soles, * about 315 BC/310 BC Soli in Cilicia of today's Turkey; † 240).

Archimedes (* about 287 BC Syracuse, Sicily; † 212/211 Syracuse).

Archytas (Ἀρχύτας, * 428 Tarentum (now Taranto in Southern Italy) ; † 347 BC Tarentum).

Lev Andreievich Artsimovich (Andreevich Arcimovich, Arcimovič, Лев Андреевич Арцимович, * 1909 Moscow; † 1973 Moscow).

Georg Wilhelm Alexander Hans Count Arco (* 1869 Gorzyce, Groß Gorschütz; † 1940).

Manfred von Ardenne (* 1907 Hamburg; † 1997) 186

Rudolf Arendt (* 1828; † 1902).

Aristoteles (* 384 BC; † 322 BC) 9

A. E. Van Arkel (* 1893; † 1976) 91

Richard Arkwright (* 1732; † 1792) 45

François Laurent Marquess d'Arlandes (* 1742; † 1809) 106

Charles François Armengaud (* 1813 Ostend in Belgium; † 1893 Paris).

Jacques-Eugène Armengaud (* 1810 Ostend; † 1891).

Jules Alexis Marie Armengaud junior (* 1842 Paris; † 1921 Paris), son of the engineers Charles François Armengaud and nephew of Jacques-Eugène Armengaud.

Pardon Armington (* 1836 Pawtucket; † 1901 Massachusetts).

Robert Thexton Armstrong (* 1909; † 1992).

Antoine Arnauld (* 1612 Paris; † 1694 Brussels).

Ludwig Achim von Arnheim (* 1781; † 1831).

Ludwig Achim von Arnim (* 1781; † 1831).

Johann Christian Arnold (* 1724 Weissenfels; † 1765 Erlangen).

Harold DeForest Arnold (* 1883; † 1933).

Niccolò Arnù (Arnu, * 1629 Mirecourt by Verdun in Lorraine or Béziers; Dominican (OP); † 1692 Bologna).

Svante Arrhenius (* 1859; † 1927).

William C. Arsem (P., * 1881 Massachusetts).

Jacques-Arsène d'Arsonval (Jacques-Arséne, * 1851; † 1940).

Valentin Osipovich Arutunov (Aroutunov, Arutyunov, Осипович Арутюнов, * 1908 the capital of Turkmenistan (Turkmenistan) Ashgabat (Aşhabád, Aşgabat) ; † 1976 Leningrad).

Abū Ishāq Ibrāhīm ibn Yaḥyā al-Naqqāsh al-Zarqālluh, Al-Zarkali, Ibn Zarqala, Arzachel (Arsechieles, * 1029; † 1087).

Johann Arzberger (* 1778; † 1835).

Asada Göryū (麻田 剛立, * 1734; † 1799).

Albert Paul Aschenbrenner († 1912).

Giuseppe Maria Asclepi (Joseph, * 1706 Macerata in the Marche region; SJ 1 July 1721; † 21 July 1776 Rome).

Augustinus Asenbaum, professor emeritus, University of Salzburg, Department of Materials Science and Physics, History of Science and Technology, flourished 1975-2014.

Eric Albert Ash (* 1928 Berlin).

St. George Ashe (* 1657/1658 county Roscommon in Ireland; † 1718 Dublin).

Isaac Asimov (* 1920; † 1992).

Allen Varley Astin (* 1904 Salt Lake City in Utah; † 1984 Bethesda northwest of Washington, Maryland).

Francis William Aston (* 1877; † 1945).

Mohamed Mohamed Atalla (محمد محمد عطالله, * 1924 Bur Sa'īd (Port Said) in Egypt; † 2009 California).

Robert d'Escourt Atkinson (* 1898 Rhayader in Wales; † 1982 Indiana).

George S. Attard is a professor of Chemistry at University of Southampton.

Ignaz count Atthemis (Ignaz Maria Maximilian Dismas Joseph Leander Attems, * 1714 Graz; † 1762 Vienna).

Maria Josepha countess Khuen von Belasi zu Auer und Lichtenberg married Attems (* 1721 Hall by Innsbruck; † 1784 Vienna).

Josef Atzl (* 1780; † 1873).

Carl Auer (Karl Auer baron Wiesbach, * 1858 Vienna; † 1929).

Pierre Victor Auger (* 1899; † 1993).

Ernst Ferdinand August (* 1795; † 1870).

Hansjochem Otto Autrum (* 1907 Bromberg; † 2003 München) zoologist, joined the Nazi NSDAP and Sturmabteilung (SA) in 1933.

Max Auwärter (* 1908 Knittlingen; † 1995).
Adrien Auzout (* 1630; † 1691).

France Avčín (* 1910 Ljubljana; † 1984 Ljubljana).

Averroes (Averrois, Averroës, Abu-al-Walid Muhammad ibn Ahmad ibn Rushd, Ibn Rušd, * 1126 Córdoba, Spain; † 1198 Marrakesh, Morocco).

Avicenna (Abu Ali al-Husain ibn Abdullah ibn Sina, * 980; † 1037).

Amedeo Avogadro (* 1776; † 1856).

Refah Mehmet Ayber (* 1921 Turkey).

William Edward Ayrton (* 1847 London; † 1908 London).

Toru Azuma (東徹, * 1953).

B

Joseph knight Baader (* 1763; † 1825).

Baba Sajurō (Sadayoshi, 馬場佐十郎, * 1787; † 1822 Edo).

Charles Babbage (* 1792; † 1871).

John Graham Backus (* 1911; † 1988 Los Angeles).

Otto Back (* 1834; † 1917).

Francis Bacon baron Verulam (* 1561; † 1626) 26

Josip Badalić (* 1888 Deanovec; † 1985 Križ southwest of Zagreb).

Lawrence Badash (Larry, * 1934 Brooklyn, New York; † 2010 Santa Barbara, California).

Luigi Bader (* 1903 Gorizia; † 1993).

Balthasar Baebler (Baldi, * 1880; † 1936).

Lev Baebler (* 1912 Žiri; † 1976).

Baeda Venerabilis (Bede, Beda, * 673 Jarrow in Durham; † 735 Jarrow).

Otto von Baeyer (* 1877 Reichenhall; † 1946 Tutzing)

Otto's father Johann Friedrich Adolf knight von Baeyer (* 1835; † 1917)

Leonard Bagni (* 1593 Pazin; † 1650 Zagreb).

François de Baillou (* abt. 1700 Italy; † 1774 Milano?).

Jean-Sylvain Bailly (* 1736; † 1793).

Alexander Bain (* 1810; † 1877).

John Logie Baird (* 1888; † 1946).

Børge Bak (* 1912; † 22 February 1990).

Thomas Baker (* 1656 Lanchester, Durham; † 2 July 1740 London).

Frederick Collier Bakewell (* 1800; † 1869 North London).

Robert A. Bakish, the president of Bakish Materials Corporation, Englewood, New Jersey established in 1965.

Luka Bakranin (* 2 October 1692, Oštarije; SJ 1712 Vienna; † 4 July 1627, Cadiz/Sevilla).

Josef Balant (Józef, Jožef Walland, * January 28, 1763 Nova vas near Radovljica; March 8, 1818 Gorizia Bishop; August 3, 1830 Gorizia Archbishop; † May 11, 1834).

Bernardino Baldi (* 1553 Urbino; † 1617 Urbino).

Christian Adolph Balduin (* 1632 Döbeln southwest of Leipzig; † 1682 Grossenhain west of Leipzig).

Giovanni Battista Baliani (* 1582 Genova; † 1666).

Françoise Balibar (born Françoise Dumesnil, * 1941 France).

William Ball (* 1561; † 1626).

William Henry Balmain (* 1817 in then British now German Helgoland North Sea island spa; † 1880 Ventnor on English isle of Wright).

Niccolò Bammacari (Bambacari, * Napoli; † 1759/1792).

Friedrich Wilhelm Banneitz (Fritz Banneitz, * 1885 Hameln on Lower Saxony; † 1940 Dresden).

Franci Bar (* December 2, 1901 St. Anton by Trieste; † November 24, 1988 Ljubljana).

Andrei Ivanovich Barancev (Андрей Иванович Баранцев) as Leningrad based author published on history of television in 1982-1986.

Alvaro Alonso Barba (* 1569 Lepe in southwest Spain; † 1662 Potosi in then Spanish Peru, now part of Bolivia).

Hermolao Barbaro (Ermolao, * 1454; † 1493).

John Bardeen (* 1908 Madison; † 1991 Boston).

George F. Barker (* 1835 Charlestown, Massachusetts; † 1910).

Nicolaus Barkey (* 1709 Bremen; † 1788 Der Haag?) obtained Ph.D. to become a professor of Evangelic theology.

Charles Glover Barkla (* 1877; † 1944).

Josep Maria Barnadas (* 1941 Alella in province of Barcelona; † 2014 Cochabamba in Bolivia).

bishop Carlo Battista Barletti (* 1735, Roccase in Alessandria province; † 1800).

Peter Barlow (* 1776; † 1862).

Jakob Barner (Barnerus, pseudonym Philiater, * 1641; † 1686).

Émile Georges Barrillon (* 1879 Mézières in Ardennes; † 1967 Montreuil-sous-bois).

Ludwig Barth von Barthenau (* January 17, 1839 Rovereto in Trentino; † August 3, 1890 Vienna).

Erasmus Bartholin (* 1625; † 1698).

Thomas Bartholin (* 1616; † 1680).

Josef Bartl (* 1850 Friesach north of Klagenfurt; † 1925 Graz).

Vladimir Bartol (* 1903 Trieste; † 1967 Ljubljana) wrote his novel *Alamut* in 1938 as the most popular work of Slovene literature worldwide.

Adolfo Guiseppe Bartoli (* 1851; † 1896).

Daniello Bartoli (Bartolis, * 1608; † 1685).

Thomas J. Barton (* 1940 Texas, coast of Mexico Gulf).

Charles Baskeville (* 1870 Deerbrook, Mississippi; † 1922 New York).

Nikolaj Gennadievich Basov (* 1922).

Laura Bassi (* 1711; † 1782).

Franjo Baš (* 1899 Kamenče 25 km west of Celje in Styria; † 1967 Ljubljana).

Gordon Battelle (* 1883; † 1923).

Abbé Charles Batteux (* 1713 Alland'Huy-et-Sausseuil, Ardennes; † 1780).

Martin Baucher (* 1594; † 1668).

Alexander Anton Bauer (Sandor, * 1836 Altenburg (Mosonmagyaróvár); † 1931 Vienna).

Jean-Geoffroy Bauer († 1783).

Otto Baumbach (* 1882 Niederwilligen in Thuringia; † 1966 Alkington, UK).

Antoine Baumé (* 1728; † 1804).

Andreas baron Baumgartner (* 1793 Frymburk in the Český Krumlov region; † 1865).

Arthur de Bausset (* 1828 France; † 1905 New York).

Teophil (Gottlieb) Siegfried Bayer (* 1694 Bohemian Lands; SJ; † 1738 Petersburg).

Sophia von Bayern-Munich (* 1376; † 1428).

Bahittin Baysal (* 1922 Kırşehir; † 2017).

Vladimir Bazala (* 1901 Zagreb; † 1987 Zagreb).

Jesse Wakefield Beams (* 1898 Belle Plaine in Kansas; † 1977).

Aleš Bebler (Baebler, * 1907; † 1981).

Anton Bebler (* 1937).

Cesare Beccaria (Marquis of Gualdrasco and Villareggio, * 1738 Milano; † 1794 Milano).

Giovanni Battista Beccaria (Beccheria, Giambattista Beccaria, * 1716 Mondovi; Piarist; † 1781 Turin).

Giacomo Bartholomeo Beccari (Iacopo, Jacopo Beccaria, * 1682 Bologna; † 1766 Bologna).

Johann Joachim Becher (* 1635 Speyer, † 1682 London).

Joseph Adam Becker (Joe, * 1897 Saar land; † 1961).

Edmond Becquerel (Alexandre-Edmond, * 1820 Paris; † 1891).

Antoine Charles Becquerel (* 1788; † 1878).

Antoine Henri Becquerel (* 1852; † 1908).

Jean Becquerel (* 1878; † 1953).

Martina Němcová married Bečvářová (* 1971 Pardubice in the Czech Republic 96 kilometres east of Prague).

Kazimir Bedeković Komorski (* 1727; SJ 1742; † 1782).

Ambrož Bedenčič (OFM; † April 4, 1750 Kostanjevica).

Wilhelm Beetz (* 1822; † 1886).

William W. Behrens III, son of the Vice Admiral William Wohlsen Behrens Jr. (* 1922 Newport; † 1986).

András Mechwart de Belecska (Andreas, * 1834 Schweinfurt; † 1907 Budapest).

Bruno Belhoste (* 1952 France).

Andrej Belič

Igor Belič (* 1919 Berlin, † 1997 Ljubljana).

Igor Belič (* 1960).

Iuriĭ Aleksandrovich Belii (Belyĭ, Юрий Александрович Белый, * abt. 1920 Dnepropetrovsk (Днепропетровск, Дніпро, Дніпро) in Ukraine).

Ivan Filipovich Beljanski (Иван Филиппович Белянский, * 1907; † 1979).

Alexander Graham Bell (* 1847; † 1922).

Angelo Bellani (* 1776 Monza; † 1852 Milan).

Manfredo Bellati (* 1848 Feltre in Belluno; † 1832 Feltre).

Giuseppe Belli (* 1791; † 1860).

Zvonko Benčić (* 1940 Senj).

Giannbattista Benedetti (Benedictis, * 1530 Venezia; † 1590 Torino).

Pope Benedict XIII (Benedictus XIII, born Pietro Francesco Orsini, later called Vincenzo Maria Orsini, * 1649; † 21 February 1730) was a pope from 29 May 1724 to his death.

Benedict XIV (Benedictus XIV, born Prospero Lorenzo Lambertini, * 31 March 1675; † 3 May 1758) was a pope from 17 August 1740 until his death.

Giovanni Batista de Benedictis (* 1622; † 1706).

Julija Pauer married Benesch (* Ljubljana).

Ladislav von Benesch (* 1845 Slavkov; † 1922 Vienna).

Ivan Benigar (* 1845 Trnovo by Ilirska Bistrica; † December 20, 1920 Radeče by Zidani Most).

Abraham Bennet (* 1749; † 1799).

Willard Harrison Bennett (* 1903; † 1987).

Michel Benoist (Benoît, Tsiang Yeou-Jen Tö-Yi, * October 8, 1715 Dijon; SJ Mach 19, 1737 Nancy; arrived in Beijing on July 12, 1744; † October 23, 1774 Beijing).

Carlo Benvenuti (Karl, * 1716; SJ; † 1789).

Seymour Benzer (* 1921 Brooklyn; † 2007 Pasadena).

Jacques Étienne Bérard (* 12 October 1789 Montpellier; † 1869 Montpellier).

Laurent Béraud (* 1703 Lyon; SJ; † 1777 Lyon).

Aristide Bergès (* 1833; † 1904).

Tobern Bergman (* 1735 Katrineberg; † 1784 Medevi).

Sigmund Bergmann (*1851 Tennstedt; † 1927 Berlin).

Emil Berliner (* 1851; † 1929).

Henri Bernard (before 1948 Henri Bernard-Maître, * 1889 Chalons-sur-Marne in France; † 1975 Chantilly in France).

Francè Bernik (* 1927 Zapuže by Ljubljana, † 2020 Ljubljana).

Natan Bernot (* 1931 Ljubljana; † 2018).

Johann Bernoulli (* 1667; † 1748).

Daniel Bernoulli (* 1700; † 1782).

Miles Berry, civil engineer, patent agent, and mechanical draftsman of a firm (John) Newton, Son & Berry in 1803-1843. Before 1817 they operated at 97 Chancery-lane, London and afterwards at 66 Chancery-lane, London.

Marcelin Berthelot (* 1827; † 1907).

Louis-Alexandre Berthier later marshal 1st Prince of Wagram Sovereign Prince of Neuchâtel (Neuschatel, * 1753; † 1815).

Claude-Louis Berthollet (* 1748, Talloires, Savoy, France; † 1822 Arcueil).

Louis Alfred Berthon (* May 25, 1838 Choisy-le-Roi, Val-de-Marne in the southeastern suburbs of Paris) Berthon associated with Tivadar Puskás Hungarian engineer and inventor who after studying law in Vienna, studied engineering at the University of Budapest. Tivadar emigrated in London in 1866, then in 1873 went to work in the United States, where he collaborated with Thomas Edison and his team, to create the "Telegraph Exchange", a multiplex which led to the construction of the first manual experimental center, it was inaugurated by the Bell Telephone Company in Boston in 1877. In February 1878, in collaboration with Edison, he introduced the phonograph to Europe and then decided to settle in Paris. After the Parisian world fair of 1878, he came closer to Josuah Franklin Bailey who represented the interests of Elisha Gray. The two men team up with Georges Alexis Godillot who gave them the capital necessary to create a new company. In return, the latter imposed one of his young engineers, Louis Alfred Berthon, for the post of technical director of A. Berthon et Compagnie, known as Edison Telephone Company. Later Berthon became the director of Parisian Société Industrielle des Téléphones (former Société Générale des Téléphones) and commercialized first French telephones in 1892/1893.

Gasparo Berti (* about 1600; † 1643).

Joseph Étienne Bertier (Berthier, * 1702/1710 Aix-en-Provence; Oratorian priest; † 1783 Paris).

Henri-Léonard-Jean-Baptiste Bertin count de Bourdeilles (* March 24, 1720 Périgueux; † 1792 a health resort called Spa in then Habsburgian Belgium).

count Henri Gatien Bertrand (* 1773 Châteauroux; † 1844).

Louis Bertrand (* 1731; † 1812).

Jöns Jakob Berzelius (* 1779; † 1848).

Anthony Bessemer (* 1758 London; † 1836).

Henry Bessemer (* 1813 Charlton; † 1898 London).

Hans Albrecht Bethe (* 1906 Strasbourg; † 2005 Ithaca, New York).

Jesse Oatman Betterton (* 1884 Porter County, Indiana; † 1960) earned a B.S. in Metallurgical Engineering at Rapid City South Dakota School of Mines in 1909 which enabled his Betterton–William Justin Kroll's industrial process for removing bismuth from lead in 1937.

François Sulpice Beudant (* 1787 Paris; † 1850 Paris).

Robert Thomas Beyer (* 1920 Harrisburg in Pennsylvania; † 2008).

Bhaskara II (* 1114; † 1185).

Jacob Franz von Bianchi (Giacomo Bianchy, Jacques, * 1732 Pognana by Como in then Habsburgian Lombardy now in Italy; † 1785 Paris), instrument maker, teacher of experimental physics at universities and at noble palaces in Mannheim, University Tübingen, Vienna, and Paris.

Francesco Bianchini (* 1662; † 1729).

Giovanni Fortunato Bianchini (Bianchi, * 1719 Chieti; † 1779 Padova).

Bartolomeo Biasoletto (* 1793 Vodnjan (Dignano) in Istria; † 1858/1859 Trieste).

Hermann Ignaz Bidermann (* 1831 Vienna; † 1892 Graz).

Shelford Bidwell (* 1848; † 1909 Weybridge in greater London).

Franz Bindlechner (* 1820; † 1897).

Gerd Binning (* 1947 Frankfurt).

Gustav Binswanger (Bynge, * 1855; † 1910 Hampstead in London).

Niccolo Bion (Nicolaus, * 1652; † 1733 Paris).

Jean-Baptiste Biot (* 1774; † 1862).

Olaf Kristian Birkeland (* 1867; † 1917).

John Betteley Birks (* 1920; † 1979 Cambridge), researched the organic scintillations at Manchester University in 1957-1979.

Dr. Philip W. Bishop was a head curator in the Division of Manufacturing at the National Museum of History and Technology, now known as the National Museum of American History, until his retirement in 1972.

Gottlieb Leopold Biwald (* 1731 Vienna; † September 8, 1805 Graz).

Joseph Black (* 1728; † 1799).

Patrick Mainars Stuart Blackett (* 1897; † 1947).

Otto Bernard Blackwell (* 1884 Bourne; † 1970 Sands Point).

Sigismund Anton Joseph Ursini Count of Blagaj (Blagay, * 1686; † 4 April 1755).

Henri Marie Ducrotay de Blainville (* 1777 Arques, near Dieppe; † 1850), a French zoologist and anatomist.

Lucien Ira Blake (J. Black, * 1854 Massachusetts; † 1916).

Jean Pierre François Blanchard (* 1753; † 1809).

Isidor Bianchi (* 1733 Cremona; Camaldolese monk; † 1807).

Pietro Blaserna (* 1836; † 1918).

Ottó Titusz Bláthy (* August 11, 1860 Tata; † September 26, 1939 Budapest).

John Paul Blewett (* 1921; † 2000).

Marta Blinc (* 1904; † 2000).

Robert Blinc (* 1933 Ljubljana; † 2011).

Felix Bloch (* 1905; † 1983).

Catharine Burr Blodgett (* 1898 Schenectady, New York; † 1979 Schenectady, New York).
Prosper-René Blondlot (* 1849; † 1930).

Johann Georg Ludolph Blumhof (* 1774 Hannover; † 1825 Giessen).

Marie Boas Hall (* 1919 Springfield in Massachusetts; † 2009).

Carl Wilhelm Bockmann (* 1773; † 1821 Karlsruhe).

Ludwig Karl Boehm (Böhm, * 1859 Lauscha in Thuringia; † after 1907 East Coast of USA).

Jan Hendrik DeBoer (* 1899 Ruinen east of Amsterdam; † 1971 The Hague).

Jan de Boer (* 1911 Haarlem west of Amsterdam; † 2010 Doorn).

Herman Boerhaave (* 1668; † 1738) 38

Alexander Aleksandrovich Bogdanov (Алекса́ндр Алекса́ндрович Богда́нов Малино́ўскі, * 1873; † 1928).

Aleksej Nikolaevič Bogoljubov (Алексе́й Николаевич Боголюбов, * 1911 Nizhyn (Нежин) in Ukraine; † 2004 Kiev (Київ)).

Henricus Bohemus († after 1440).

David Joseph Bohm (* 1917 Pennsylvania USA; † 1992 Hendon UK).

Johann Conrad Bohn (* 1831 Bornheim district of Frankfurt; † 1897).

Niels Hendrik David Bohr (* 1885; † 1962).

Paul Émile Lecoq de Boisbaudran (* 1838; † 1912).

Ferdinand François Désiré Budan de Boislaurent (* 1761 Haiti; † 1840 Paris).

Etbín Bojč (pseudonym Janez Poljanec, * 1906 Vače; † 1975, Ljubljana).

Slavko Bokšan (Славко Бокшан, * 1889 Đurđevo (Ђурђево) in Serbian Vojvodina; † 1953 Beograd).

Werner von Bolton (* 1868; † 1912) 85

Arthur Boltzmann (* 1881; † 1952).

Ludwig Boltzmann (* 1844; † 1906).

Jacques-Christophe Valamont de Bomare (* 1731; † 1807).

Guido Bonatti (* 1210; † 1296).

Josip Boncelj (* 1884 Železniki; † 1971 Zagreb).

Janez Bonča (* 1960 Ljubljana).

Probir Kumar Bondyopadhyay (Bondy), forensic historian of science and technology in Houston, owner of USA patents.

Ivo Bonelli (OFMobs; † September 22, 1809 Ljubljana).

Emil Bönnelyck (Bonnelyck, * 1893; † 1953).

Lucio Bonora, presbyter at the Diocese of Triviso in Veneto ordained on February 19, 1977.

Harry Boot (* 1917; † 1983).

Hubert Cecil Booth (* 1871; † 1955 Croydon in south London).

Karl Boranga (* 1640; SJ; † 1684).

Johann Albert Wilhelm Borchers (* 1856 Goslar; † 1925 Goslar)

Jean-Charles chevalier de Borda (knight, * 4 May 1733; † 19 February 1799).

Frédéric Bordas (* 1860; † 1936).

Gail Borden, Jr. (* 1801 Norwich, New York; † 1874 Borden, Texas).

Émile Borel (* 1871 Saint-Affrique, Midi-Pyrénées; † 1956 Paris).

Giovanni Alfonso Borelli (Joseph Alphonso, * 1608 Napoli; † 1679 the school of Piarists in Rome).

Vasilij Petrovič Borisov (Василий Петрович Борисов, * 1937 Oryol (Orel, Орёл) in western Russia) specialist in vacuum technique and historian at Russian academy of sciences.

Curt Borchardt (Kurt Borchardt-Toronto), PhD research on Berliner underground transport at University Erlangen granted on 4 July 1917, published about television in Germany in 1929-1950.

Baron Ignaz Born (* 1742 Karlsberg (Karlsburg, Kapnik) in Transylvania; SJ 1761-1762 as novice in Vienna; † 1791).

Stanislav Antonowitsch Borowik (Боровик Станислав Антонович Боровик, * 1882; † 1958).

Tatjana Fedorovna Borowik-Romanov (Татьяна Фёдоровна Боровик-Романова, Romanow, * 1896 Tomsk; † 1981).

Wiktor-Andrei Stanislawowitsch Borowik-Romanow (Виктор-Андрей Станиславович Боровик-Романов, * 1920 Leningrad; † 1997).

Bodo von Borries (* 1905 Herford; † 1956 Aachen), married Hedwig Ruska as brother-in-law and institute collaborator of Ernst Ruska.

Tomo Bosanac (* 1918 Bjelovar; † 2003 Zagreb).

Jagadish Chandra Bose (* 1858; † 1937).

Johann Andreas Bose (* 1626; † 1674).

Luigi Bossi (count, a son of marquis, * 1758 Milano; † 1835 Milano).

Nicolaus Bossicart (Bossicar, * 1739; SJ).

Rudjer Josip Bošković (Rudžer, * 1711; † 1787).

James Thomson Bottomley (1845 Fort Breda in Ireland-1926 Glasgow), Kelvin's nephew.

Johan Nepomuk Bottoni (* 1707; † 1790 Krems).

Pierre Bouguer (* 1698 Bretagne; SJ; † 1758).

Nicolas-Antoine Boulanger (* 1722; † 1759)

Bouliguine (Николай Павлович Булыгин, * 1847 Petersburg; † 1912 Crimea).

Ismaël Boullualdi (Bullialdi, * 1605; † 1694).

Henrique Count Chambord, Duke of Bordeaux of Bourbon house (* 29 September 1820; † 24 August 1883 Viennese Neustadt).

king Charles (Karl) X Bourbon (* 1757 Versailles; king from 1824 until 1830; † 1836 Gorizia).

Ludvik XIV (Louis Bourbon, * 1636; king in 1643; † 1715).

king Ludvik XVI (Louis Bourbon, Ludwig, * 1754; † 1793).

king Louis XVIII Bourbon († 16 September 1824).

Eugène Bourdon (* 1808 Paris; † 1884 Paris).

Karl Ludwig Hummel de Bourdon (* 1769 Besançon in France, † 23. April 1840 Leopoldstadt 9 (2, Obere Donaustraße 81, today Numbers 93-95).

François Bourgeois (Francis Burgeois, Tch'au Tsuen-Sieu, Tsi-Ko, * March 21, 1723 Pulligny (Meurthe) in Lorraine; SJ September 17, 1740 Nancy; † July 29, 1792 Beijing).

Robert W. Bower (* 1936 Santa Monica).

Brian Bowers (* abt. 1942 UK) obtained his PhD at Kings College London, formerly Senior Consultant of Electrical Engineering (Lighting and Electric Power) at the Science Museum, London, UK, later consulted on many museum projects in Britain and overseas.

John Zimmerman Bowers (* 1913 Catonsville, Maryland; † 1993 Harrogate healthcare center in Lakewood, N.J.)

Robert Boyle (* 1627; † 1691).

Richard Boyle, first Count Cork (* 1566; † 1643)

Michel Boym (* 1612; † 1659).

Jean Gabriel Boyvin (* 1605 Vire in Normandy; OFMobs; † 1681 Vire).

Cyrus Fogg Brackett (* 1833 Parsonfield, Maine; † 1915).

James Bradley (* 1693; † 1762).

Tycho Brahe (* 1546; † 1601 Prague).

William Henry Bragg (* 1862; † 1942).

William Lawrence Bragg (* 1890; † 1971).

Elena Brambilla (* 1942 Milano; † 2018 Milano).

Benjamin Bramer (* 1588 Felsberg; † 1652 Ziegenhain).

William Thomas Brande (* 1788; † 1866) 235

Georg Friedrich Brander (* 1713 Regensburg; † 1783 Augsburg).

Hennig Brandt (Brand, * around 1630 Hamburg; † 1710 Hamburg).

Arno A. Brasch (* 1910 Berlin; † 1963 New York City).

Mijo Brašnić (* 1849; † 1868).

Walter Houser Brattain (* 1902 Xiamen (Amoy) at southeast China coast; † 1987 Seattle).

Carl Ferdinand Braun (Karl, * 1850 Fulda; † 1918 New York).

Auguste Bravais (* 1811; † 1863).

Abraham-Louis Breguet (* 1747 Neuchâtel (Neuenburg) in western Switzerland; † 1823 Paris).

Louis Bréguet (* 1804; † 1883).

Johann Friedrich August Breithaupt (* 1791 Probstzella; † 1873 Freiberg).

Ivan (Miloš) Brelih (Mihael, Mitja, * 1916 Trebnje; † 2002 Ljubljana).

Louis George Oudard Feudrix de Bréquigny (* 1714 Granville, Manche in Normandy; † 1795 Paris).

David Brewster (* 1781; † 1868).

Annibale Briganti (* about 1520 Chieti; † 1582 Chieti).

Arthur Aaron Bright junior (* 1917; † 1953) received his PhD at Amos Tuck School of Administration and Finance in 1940. Based in New England worked for Department of Economics and Social Science of MIT.

Josip Brigido von Brezovica (* 1736, Trieste; † 1817, Vienna).

Gervais Brisacensis (* 1648 Breisach; OFMCap; † 1717).

Mathurin Jacques Brisson (* 1723; † 1806).

Fortunatus Brixianus (Brixia, Brixanus, Girolamo Ferrari, * * 1701 Brescia; 1718 OFMConv Borno by Brescia; † 1754 Madrid).

Max Brod (* 1884; † 1968).

Roger Lord Broghill, first Count Orrery (* 1621; † 1679).

Louis de Broglie (* 1892; † 1987).

Maurice de Broglie (* 1875; † 1960).

Alexandre Brongniart (* 1770 Paris; † 1847 Paris).

Otto von Bronk (* 1872 Gdansk; † 1951 Berlin).

Lord William Brouncker (* 1620; † 1684).

Andrew Philip Brown (* 1950 London, England), immigrated to the United States to join Harvard in 1990.

Edward Brown (Browne, * 1644 Norwich in Norfolk; † 1708).

Sanborn C. Brown (* 1913 Beirut; † 1981 Henniker, N.H.).

William Charles Brown (* 1927).

Jan Brozek (Joannes Broscius, * 1585; † 1652 Bronowice in Krakow).

Ernst Carl Reinhold Brüche (* 1900 Hamburg; † 1985 Mosbach in the northern Baden-Württemberg).

Ernst Wilhelm Ritter von Brücke (* 1819 Berlin; † 1892 Vienna).

Urban Friderick Benedict Brückmann (* 1728; † 1812).

Luigi Valentino Brugnatelli (* 1761 Pavia; † 1818 Pavia).

Charles Francis Brush (* 1849 Euclid, Ohio; † 1929).

Stephen George Brush (* 1935 Orono in Maine).

Stephen S. Brush (* 1929).

Spiridon Brusina (* 1845; † 1908).

Ferdinand Brusotti (* 1837; † 1899 Pavia).

Harry Brynielsson (* 1914 Stockholm; † 1995 Vaxholm).

Hans Buchner (* 1850; † 1902).

Oliver Ellsworth Buckley (* 1887 Sloan, Iowa, United States; † 1959, Newark, New Jersey).

Vesna Bučić (* 1926 Zagreb, Croatia).

Pavel Budimir (Budnovich, Budnović, * Cetinje; OFMobs; † April 3, 1670 Pičen in Istria).

Gersh Itskovich Budker (Герш Ицкович Будкер, Andrey Mikhailovich, * 1918 Murafa in Ukraine; † 1977 Akademgorodok).

Heinrich Buff (* 1805; † 1878).

Count Georges Louis Leclerc de Buffon (* 1707; † 1788)

Zmago Bufon (Zmagoslav, * 1910 Rojan by Trieste; † 1973, Ljubljana).

Sara Chapman Thorp married Bull (* 1850 Upstate New York; † 1911 Cambridge, Massachusetts), promoter of Jagadish Chandra Bose's inventions, a disciple of Swami Vivekananda like Tesla.

Barbara Hamilton Bunce (* 28 March 1925 Pennsylvania, United States; † 27 July 1991 Oberlin, Lorain, Ohio) married the Oberlin college professor of British parliamentary and legal history of the 19th century Barry McGill (* 1924; † 1996).

Michele Francesco Buniva (* 1761; † 1834).

Robert Wilhelm Bunsen (* 1811; † 1899).

Rointan Framroze Bunshah (Ron, * 1927 Bombay (Mumbai) in India; † 1999 Los Angeles?).

Aleš Bunta (* 1974 Ljubljana), Slovenian philosopher.

Hans Hugo Christian Bunte (* 1848 Wunsiedel; † 1925 Karlsruhe).

Emanuel Bunzel (* 1828 Prague).

Tytus Liwius Burattini (* 1617; † 1681).

Cecil Reginald Burch (* 1901 Leeds; † 1983).

Francis Parry Burch (* 1899; † 1933).

George James Burch (* 1852; † 1914).

Gregor Burdun (Bourdoun, Григорий Дмитриевич Бурдун, * 1907; † 1980).

Adam baron Burg (* 1797 Vienna; † 1882 Vienna), professor of mathematics at the Viennese University of Technology.

Reinhold Burger (* 1866; † 1954).

Joost Bürgi (Jobst, Jöst, * 28 February 1552 Lichtensteig in Switzerland; † 1632 Kassel).

Johannes Buridanus (Jean Buridan, * abt. 1295; † 1358/1363).

Gualterius Burlaeus (Walter Burley, Gualterus Burleus, * abt. 1274; OFM; † about 1345).

Bishop of Salisbury Gilbert Burnet (* 1643 Edinburgh; † 1715 London).

Laurence Burns (* 1905 Boston, Suffolk County, Massachusetts, USA; † 1972 Lynn, Essex County, Massachusetts, USA), obtained his B.S. at Massachusetts Institute of Technology, Dept. of Electrical Engineering in 1927, published for Massachusetts Institute of Technology, Rogers Laboratory of Physics in 1929-1930, resided in Swampscott, Essex County, Massachusetts while publishing for Sylvania Electric Products Inc., Salem, Massachusetts in 1948-1958.

Moses Burstyn (* 1841 Lvov; † 1908).

Ayhan married Busch (* 1934).

Hans Busch (* 1884; † 1973)

Karl Busch (* 1929 Lörrach).

Vannevar Bush (* March 11, 1890 Everett; † June 28, 1974 Belmont).

Gordon Bussey, published about the history of TV and wireless in 1976-2002

Christoph Heinrich Diederick Buys-Ballot (* 1817; † 1890).

John Byron (* 1723; † 1786).

Niccolò Cabeo (Nicolaus Cabeaus, * 1586 Ferrara; SJ; † 1650 Genoa).

August André Thomas Cahours (* 1813 Paris; † 1891).

Louis Paul Cailletet (* 1832; † 1913) 88

Florian Cajori (* 1859 St Aignan by Thusis in the easternmost canton Grisons (Graubünden) in Switzerland; † 1930 Berkeley).

Caelius Calcagninus (Celio Calcagnini, * 1479 Ferrara; † 1541 Ferrara).

Nicholas Joseph Callan (* 1799 Darver between Drogheda and Dundalk north of Dublin; † 1864 Maynooth east of Dublin).

Adolph Carl Peter Callisen (* 1786 Glückstadt in then Danish Holstein of Schleswig-Holstein; † 1866 Wandsbek borough of Hamburg).

Caspar Calvör (Calvoer, * 1650 Hildesheim; † 1725 Clausthal).

Franz Ludwig von Cancrin (Kankrin, * 1738; † 1812).

St. Joannis Cantii (Jan z Kęt, Jan Kanty, * 23 June 1390; † 24 December 1473).

John Canton (* 1718; † 1772 London).

Georg Cantor (* 1845 Sankt Petersburg; † 1918 Halle).

Moritz Benedikt Cantor (* 1829 Mainz; † 1920 Heidelberg).

José Raúl Capablanca y Graupera (* 1888; † 1942).

Philip Caraman (* 1911 Hippodrome in North London UK; SJ; † 1998 Brushford, Somerset).

Archbishop of Ravenna Cardinal Alois Caponio (Luigi Capponi, * 1583 Firenze; † 1659 Roma).

Bruno Carazza, historian of physics, in 2010/213 retired at the Department of Physics and Earth

C

Sciences University of Parma (Università degli Studi di Parma).

Girolamo Cardano (* 1500; † 1576).

Donald Stephen Lowell Cardwell (* 1919 Gibraltar; † 1998 Macclesfield, Cheshire),

Luigi Aloys Caren (* 1766, Pavia; † 1810, Vienna).

George R. Carey (* 1851 Malden, Massachusetts; † 1906).

Count Gian Rinaldo Carli (Caroelius, * 11 April 1720 Koper; † 1795 Cusano, today in Milano).

Giovan Girolamo Carli (* 1719 Ancaiano (Siena); † 1786 Mantova).

Count Girolamo Carli (* 1726 Koper; † 1791/1793 Milano).

Vincenzo Carnava († 1615).

Lazare Carnot (count, * 1753; † 2 August 1823).

Sadi Carnot (* 1796; † 1832).

Francisco Caro (Francesco Caro, Franciscus Carus, Cari), published 1665-1692 as Somaschi friar professor in Padua.

Ferdinand Philippe Edouard Carré (* 1824 Moislains in Somme; † 1900).

Jean De Carro (* 1770 Geneva; † 1857 Karlovy Vary (Carlsbad)).

Philip Carteret (* 1733; † 1796).

Gallo Cartier (Gallus, * 1693 Pruntrut (Porrentruy) in northwest Switzerland; OSB Ettenheimmünster by Freiburg im Breisgau; † 1757 Ettenheimmünster?).

Paul Carus (* 1852 Ilseburg, Saxony; † 1919 La Salle, Illinois).

Paolo Casati (* 1617; † 1707).

Vincenzo Cascariolo (Casciriolo, Casciarolo, * 1571 Bologna; † 1624 Bologna).

Abbé Giovanni Caselli (* 1815 Sienna; † 1891 Florence).

Hendrik Brugt Gerard Casimir (* 1909; † 2000).

César Francois Cassini de Thury (Cassini III, * 1714; † 1784).

Dominique Cassini (Giovanni Domenico Cassini I, Jean-Dominique. * 1625 Perinaldo; † 1712 Paris).

Jean-Dominique count Cassini (* 1748; † 1845) son of César-François Cassini de Thury.

Louis Bertrand Castel (Louis-Bertrand, * 1688 Montpellier; SJ 1703; † 1757).

Abbé Benedetto Castelli (* 25 April 1577 Brescia; † 1644).

Davide Castelvecchi, a staff reporter at *Nature* in London and a contributing editor for *Scientific American*.

Giovanni Francesco Melchior Castillon (* 1708; † 1791).

Claude-Nicolas Le Cat (* 1700; † 1768 Rouen).

Joseph de Catharin at Graz University in 1772 related to Sigmund R. Ritter von Katharin († 1778).

Bonaventura Belluto Catanensi (* 1599/1600 Catania in Sicily; OFMconv; † 1676 Catania).

Baron Augustin-Louis Cauchy (* 21 August 1789 Paris; † 23 May 1857).

Louis-François Cauchy (* 1760; † 28 December 1848).

Blanche Mojon married Cavaignac (* 1854; † 1931).

Godefroy Cavaignac (* 1853; † 1905).

Clemente Baroni Cavalcabò (* 1726 Sacco in Trentino; † 1796 Sacco).

Italian Tiberio Cavallo (* 1749; † 1809).

Charles lord Cavendish (* 1704; † 1783).

Henry lord Cavendish (* 1731; † 1810).

Margaret Lucas Cavendish, Duchess of Newcastle-upon-Tyne (* 1623; † 1673).

John Cawley (Calley, * 1663; † May 1725 The Hague).

Robert Cay (* 1807; † 1888).

Jean-André Cazalet (* 1753 Anglès; † 1825 Bordeaux).

Jean Cazenobe (* 1926; † 2014 Paris), director of research at Parisian CNRS.

Barbara of Celje (Cilli, * 1392 Celje; † July 11, 1451).

Friderik II of Celje (* about 1365 Celje; † 1454)

Herman I of Celje (* 1333; † 1385).

Herman II of Celje (* 1365; † 1435).

Margaret of Celje († 1480).

Ulrich II of Celje (* 1406; † November 9, 1456 Beograd).

Conrad Celtes (Celtis, * 1459; † 1508).

Federico Cesi (* 1585; † 1630).

Antonio Cetti (* 1752; † 1835).

Giovanni Ceva (* 1647 Milan; † 1734 Mantua).

Tommaso Ceva

James Chadwick (* 1891; † 1974).

Alexander Chalmers (* 29 March 1759 Aberdeen Scotland; † 29 December 1834 London).

Ephraim Chambers (* abt. 1680; † 15 May 1740 London).

Robert Champeix published in vacuum technique in French language in 1950-1996.

Jean-Étienne Vachier Championnet

Sivaramakrishna Chandrasekhar (* 1930; † 2004).

Subrahmanyam Chandrasekhar (* 1910 Lahore; † 1995).

Octave Chanute (* 1832; † 1910).

Jean Chapelain (* 1595; † 1674).

Jean Antoine Claude Chaptal count de Chanteloup (* 4 June 1756 Nogaret; † 30 July 1832 Paris).

Jacques Alexandre César Charles (* 1746; † 1823).

Charles de Changy (* 1817 Saint-Avertin in France).

Margaret Cheney (* April 5, 1921 Eugene, Oregon in the Pacific Northwest).

Pavel Alekseevich Cherenkov (* 1904; † 1990).

Hai Nei Shih Chou Chi (十州記, Hainei shizhou ji, 海內十洲記, flourished in fourth or fifth-century BCE)

Adam Mathias Chmel (* 1770 Teschen; † 1832 Linz).

Christian Christiansen (* 1843; † 1917).

Nicholas Constantine Christofilos (Νικόλαος Χριστοφίλου, * 1916 Boston; † 1972).

Zhou Chu (Chou-Chum 周處, courtesy name Ziyin 子隱, * 236; † 297).

William A. Chupka (* 1923 Pittston; † 2007).

Morishima Chūryō (Katsurgawa Hosai, courtesy name Shinra Bansō or Nisei Fūrai Sanjin in the

meaning of the second Fūtai Sanjin, 森島中良, * 1754; † 1810?).

Pierre-Martial Cibot (* 1727 Limoges, France; SJ; † 1780 Beijing, China).

Marcus Tullius Cicero (* 106; † 43 BC).

Vladislav Cieszynsko-Glogovski († 1463) the son of the Silesian Duke.

Edvard Cilenšek, Strojnik's PhD student of electrostatic Van de Graaff accelerator at Ljubljana Faculty for Electrotechnics and Machine Engineering in 1962-1965.

Gaetano Cioni (* 1760 Firenze; † 1851 Firenze).

Walker Lee Cisler (* 1897 Marietta, Ohio; † 1994).

Kristof from Cividale (Čedad, * 1606; OFMCap 1623; † 5 September 1674).

Ante Cividini (* 1881 Brod Na Kupi; † 1968 Ogulin).

Zorica Civrić (* abt. 1960), Senior Curator of the Museum of Science and Technology in Beograd, former curator at Nikola Tesla Museum in Belgrade in 1988-2007.

Latimer Clark (* 1822; † 1898).

Noel Anthony Clark (* 1940 Cleveland).

Charles Lorenzo Clarke (* 1853 Portland Maine; † 1941 Portland Maine).

Samuel Clarke (* 11 October 1675 Norwich; † 17 May 1729) an Anglican clergyman who translated Newton's Optics into Latin Language in 1706 and polemicized with Leibniz.

André Claude († 1955).

Georges Claude (* 1870 Paris; † 1960 Paris).

Rudolf Clausius (* 1822; † 1888).

Christopherus Clavius (* 1537; † 1612).

Nicholas Clément (Clément-Désormes after his marriage in 1820, * 1779 Dijon; † 1841 Paris).

Jean le Clerc (* 1657; † 1736).

Robert William Cloud (* 20 August 1914 Madison, Indiana), of Massachusetts Institute of Technology.

Carolus Clusius (Charles de L'Écluse, * 1526 Arras; † 1609 Leiden).

Philippus Cluverius (Cluverij, * 1580; † 1622).

Ta-Nehisi Paul Coates (* 1975 Baltimore, Maryland).

count Janez Filip Cobenzl (Johann, † 1697).

baron Joannes Raphael Cobenzl (Kobenzl, * 1571; † 1627).

John Douglas Cockcroft (* 1897; † 1967).

baron Anton Codelli III von Fahnenfeld (* 22 March 1875 Naples; † 26 April 1954 Porto Ronco near Ascona).

Anton Sixtus Rudolf Codelli von Codellisberg, Sterngreif and Fahnenfeld (Sikst, * 21 November 1923).

Ilona von Drasche-Lazar de Thorda married baroness Codelli (Ily Lázár, * 4 May 1904 Budapest).

Karl Anton Codelli (* 17 September 1902; † 17 September 1921).

Karl Jožef baron Codelli von Fahnenfeld (* 1846; † 1878 Pula).

Maria (Miryam) Julie Karoline Rosalie Codelli (* 1874 Pula, Istria; † 1935) first married Ernst Karl Stadler von Wolffersgrün, next married Ljubljana born Max Samassa.

Rosalia baroness Taufferer married baroness Codelli (Rozalija, * 1852; † 1938 Ljubljana), Karl Jožef's wife, mother of Anton and Miryam

Bernard Leonard Cohen (* 1924 Pittsburgh; † 2012).

Jean-Baptiste Colbert Marquis Seignelak (* 1619; † 1683).

Jacques-Nicolas Colbert (* 1655 Paris; † 1707 Paris) the abbot of Le Bec-Hellouin, Parisian academician in 1678, in 1681-1685 the titular archbishop of Carthage, after 1691 archbishop of the former Pascal's Rouen, the youngest son of the minister Jean-Baptiste Colbert who made Du Hamel the secretary of Academy.

Giuseppe de Coletti (* 1744 Rome; † January 1815 Trieste).

Peter Collinson (* 1694 Hugal Hall in northwest England; † 1768 London).

Prince Maria Colloredo-Walsey (Mary Waldesee, Wallsee, * 1735; † 1818).

Edwin Colpitts (* 1872; † 1949).

Bonaventura Columbus (Columbi, Columbo, Colombo, * abt. 1600 Nice; OFMconv, published 1637-1648).

Federico Commandino († 1575).

Philibert Commerson (* 1727; † 1773).

Arthur Holly Compton (* 1892; † 1962).

Carl Taylor Compton (* 1887; † 1954).

Carleton Thomas Compton (* 1592/1593 Cambridgeshire; SJ 1617; † (1665/1666 Liège).

James Bryant Conant (* 1893 Dorchester in Boston; † 1978 Hanover in New Hampshire).

Charles Marie de La Condamine (* 1701; † 1774).

Abbot Étienne Bonnot de Condillac (* 1715; † 1780).

Edward Uhler Condon (* 1902 New Mexico; † 1974 Colorado).

Pietro Configliachi (* 1777 Milano; Barnabite priest; † 1844 Cernobbio).

Timothy K. Conley, professor of English at Bradley University.

Johann Michael Conradi († 1742 Dresden).

Antonio Conti (Abbate Schinella Conti, * 1677 Padua; Oratorian monk; † 1749 Padua)

Natale Conti (Natalis Comes, Natalis de Comitibus, Noël le Comte (* 1520; † 1582).

Harold John Cook (* 1952 USA).

captain James Cook (* 1728 Marton-in-Cleveland, Yorkshire, England; † 1779 Kealakekua Bay, Hawaii).

William David Coolidge (* 1873 Hudson, Massachusetts; † 1975).

Nicolaus Copernicus (* 1473; † 1543).

Paul Bruce Corkum (* 1943 Saint John seaport city of the Atlantic Ocean on the Bay of Fundy in the province of New Brunswick, Canada) researches atoms and plasmas in super-intense laser fields at Canadian National Research Council's Steacie Institute, Ottawa.

Melchior Cornaeus (* 1598 Brilon; † 1665 Mainz).

Elena Lucrezia Cornaro Piscopia (Helena Corner, * 1646 Venice; † 1684 Padua) buried after funeral oration of Francesco Caro).

Marie Alfred Cornu (* 1841; † 1902).

Vicenzo Coronelli (* 1650; OFM 1665; † 1718).

Cipriano Coronini (Giovanni, * 1500; † 1597).

Rudolf Antonio Maria Coronini (* 10 January 1731 Gorizia; † 4 May 1791 Gorizia)

Matthias Hunjady Corvinus (Hunyady Korvin, * 1443; † 1490).

Vernon Ellis Cosslett (* 1908; † 1990).

Domenico Cotugno (* 1734, Ruvo di Puglia; † 1822, Naples).

Maurice Marie Alfred Couette (* 1858 Tours; † 1943 Angers).

Ernest David Courant (Ernst, * 1920 Göttingen).

Antoine Augustin Cournot (* 1801 Gray in eastern France; † 1877 Paris).

Jean-Marie-Joseph Coutelle (* 1748; † 1835).

Thomas George Cowling (* 1906 Hackney/Walthamstow in North East London; † 16 June 1990 Leeds), an English astronomer.

Irving B. Crandall (* 1890 Chattanooga, Tennessee; † 1927).

Heinrich Johann Nepomuk von Crantz (* 1722 Roodt-sur-Eisch in Luxemburg; † 1799 Judenburg).

Adair Crawford (1749; † 1795).

Elisabeth T. Crawford (* 1937 Sweden; † 1 April 2004 Fountain Hill, Pennsylvania, United States).

Lorenz Florenz Friedrich von Crell (* 1744 Helmstedt (Helmstädt) in Lower Saxony; † 1816 Göttingen).

August Leopold Crelle (* 1780; † 1855).

John C. Crepeau, professor and dean of undergraduates at Department of Mechanical Engineering of University of Idaho in Moscow, USA.

Charles Critchfield (* 1910 Ohio; † 1994 Los Alamos).

Oswald Croll (* about 1560 Hessen-Kassel; † 25 December 1609 Prague).

Alistair Cameron Crombie (* 1915 Brisbane in Australia; † 1996 Oxford UK).

Oliver Cromwell (* 1599; † 1658).

William Crookes (* 1832; † 1919).

James Arnold Crowther (* 1883; † 1950).

Eleonora Maria Rosalia duchesse Crummau Eggenberg married Liechtenstein (princess Eckenberg, duchesse Troppau and Jägerndorf, * 1647; † 1704).

Alessandro Cruto (* 1847; † 1908 Torino).

Janez Baptist Cruxilia (Križnič, * 23 June 1623 Tolmin; † 1684 Klagenfurt).

Ctesibius (Ktesibios, Tesibius, * 285; † 222 BC).

William Cullen (* 15 April 1710 Hamilton; † 5 February 1790 Edinburgh).

Milan Cundev (Милан Цундев, Faculty of Electrical Engineering and Information Technologies, Ss. Cyril and Methodius University, Skopje, Macedonia (ФЕЕИТ, ФЕЕИТ, Електротехничкиот факултет, Универзитет Св. Кирил и Методиј-Скопје).

Marie Curie (* 1867; † 1934).

Jože Vid Curk (* 1924 Vipava; † 2017).

Albert von Curtz (Curtius, pseudonym-anagram Lucius Barrettus, * 1600 Munich; SJ 1616; † 19 December 1671 Munich).

Nicholas of Cusa (Nicholas of Kues, Nicolaus Cusanus, * 1401; † 1464), the cardinal.

Edward Lansing Cussler (* 1940) formerly at University of Wisconsin-Madison, now professor of chemical engineering of Minnesota University Twin Cities in Minneapolis and St. Paul.

Franc Cvelbar (France, * 1932).

Uroš Cvelbar (* 1975 Ljubljana).

Grant Konstantinovič Cverava (Грант Константинович Цверав, T̄sverava, * 1911 Akhaltsikhe in southern Georgia (Ахалцѝхе); † 1994).

Jerzy Marian Cygan (* 1924 Sobieniach Szlacheckich 38 km south-east of Warsaw; OFMcap; † 2006 Lublin in Lesser Poland).

Josef Czermak (* 1825/26; † 1872).

Paul Czermak (* December 27, 1857 Brno; † 1912 Innsbruck)

Johann Rudolf Count Czernin von Chudenitz (* 1757; † 1845).

Fran Čadež (* 1882; † 1945).

Marijan Čadež (Marjan, * 1912 Gorizia (Gorica); † 2009, Ljubljana).

Albert Čebulj (* 1918 Glarus in Switzerland; † 1995).

Philip Čeferin (Zeferin, Ceferin, * 1630; SJ; † 1666)

Pavel Čech (Cech, * 1944 Sobotka (Saboth) in north central Bohemia), head of the cabinet of medical history (Division-Department of History of Medicine, Dějiny lékařství) at Third Faculty of Medicine in Charles University in Prague (MFKU).

Miha Čekada, IJS.

Mojca Čepič investigates antiferroelectric liquid crystals and liquid crystals formed of more complex molecules at IJS and at Faculty of Education in Ljubljana.

Lavo Čermelj (* 1889; † 1980)

Evgen Černigoj (* 1908 Cesta by Vipavski Križ).

Avrelj Čeuko (OFM; † 16 May 1746 Ljubljana).

Anton Čokl (Tschokl, * Vienna; † 8 February 1779 Ljubljana).

Milan Čopič (* 1925; † 1989).

Ivana Čornejová (* 1950 Prague).

Franc Čuden († 1912).

Bibiana Dobovišek married Čujec (* 25 December 1926 Ljubljana).

Iskra Vasiljevna Čurkina (Vasil'evna, Искра Васильевна Чуркина, * 1931 Moscow).

D

Franc Dabrovič (* 1720 Požega; † 1767).

Fernand Dacos (* 1892 Liège; † 1977), by his female ancestors a descendant of Zénobe Gramme.

Žarko Dadić (* 1930 Split).

Louis Daguerre (* 1789; † 1851).

Odd Dahl (* 1898 Drammen in Norway; † 1994 Norway).

His son Per Fridtjof Dahl (* 1932 Washington D.C.; † 2011 Emeryville, California).

Florian Dalham a. Sta. Theresia (* 1713 Vienna; Piarist; † 1795 Salzburg).

André-Louis Danjon (* 1890 Caen; † 1967 Paris).

John Dalton (* 1766; † 1844).

Gabriel Daniel (* 1649 Rouen; SJ; † 1728 Paris).

John Frederick Daniell (Frederic, * 1790; † 1845 London).

Daniel Semenovich Danin born Plotke (Daniil Semenovič, Даниил Семёнович Плётке after 1938 known under his pseudonym Данин, * 1914 Vilnius; † 2000 Moscow) of prominent intellectual Jewish family of Lithuania. Began as literary criticist, scenario author, and poet. In the middle of political prosecutions, he remembered his pre-war studies of physics to become highly successful populariser of science in 1957-1982.

Rudolf Danninger worked for the Viennese Institute for Radium Research (Institut für Radiumforschung).

Jean Casimir Danysz (Jan Kazimierz, * 1884 Paris; † 1914 Cormicy).

Oliver Darrigol (* 1955 Caudéran now part of Bordeaux in southwestern France).

Darko Darovec (* 1961 Koper).

Charles Robert Darwin (* 1809; † 1882).

Charles Galton Darwin (* 1887; † 1962).

Erasmus Darwin (* 1731; † 1802).

Johann E. Dassenbacher, flourished 1864-1911, in 1864 taught classical languages in Opava (Troppau), in 1874 taught at Český Krumlov (Krumau) real Grammar school, retired as Graz Grammar school professor in 1911.

Anton E. Daul, published on history of technology mostly in Vienna in 1890-1906.

Alexandre Dauvillier (* 1892 Saint-Lubin-des-Joncherets; † 1979 Bagnères-de-Bigorre).

Stephen Davenport (* 1701).

Boris Davidov (Davydov, Борис Иосифович ДАВЫДОВ (* 1908 Petersburg; † 1963 Moskva).

Amy Davidson (* New York) in 2017 married David James Sorkin in a Jewish ceremony in Manhattan.

John Arthur Davies (* 1927; † 2016 Deep River, Renfrew County, Ontario, Canada).

Clinton Joseph Davisson (* 1881; † 1958).

Humphry Davy (* 1778; † 1829).

Peter Debye (* 1884; † 1966).

Claude François Millet Dechaies (* 1621 Chambéry 100 km east of Lyon; SJ 1636; † 28 March 1678 Turin).

Jakob Degen (* 1760 Switzerland; † 1848 Vienna).

Alenka Dekleva married Likar (* 1929 Ljubljana; † 1995).

Janez Dekleva (* 1925 Ljubljana; † 2011).

Robert K. DeKosky (Bob, * 1945 Pennsylvania? (Rocke, 2001, 22)).

Jean-Claude Delamétherie (de la Métherie, * 1734; † 1817).

François-Étienne Delaroche (De la Roche, * 1781 Geneva; † 1813 Paris).

François general Delaroche (* 1775 Ruffec; † 1815 Ruffec).

Joseph Nicolas Delisle (d'Isle, Lisle, * 1688 Paris; † 1768).

Piero Del Negro (* 1941).

Eugène-Anatole Demarçay (* 1852 Paris; † 1903 Paris)

Harry L. Dember (* 1882 Leimbach quart of Mansfeld; † 1943 New Brunswick, New Jersey), as a Jew escaped from Germany in 1933.

Democritus from Abdera (* 470 BC; † 380 BC).

Janez Dencel (Denzl, Dencel), the owner of bell-foundry and smelting-plant in Maribor in 1869-1898 (Zvonarna in livarna g. Janeza Dencel-na in sinova).

Franc Derganc (* 1877 Semič; † 1939 Ljubljana).

William Derham (* 1657; † 1735).

Miksa Déri (Max, * 1854 Bács (Bač in Vojvodina); † 1938 Merano).

John Théophile Désaguliers (* 1683; † 1744).

Paul Quentin Desains (* 1817; † 1885).

René Descartes (* 1596; † 1650).

Veronika von Desenice (Deseniška, Dessnitz, Dessenitz, Desnicze, Teschnitz, Teschenitz, Dessewitz, Hatschen, Kotschee, * Hrvatsko Zagorje; † 1425/1428 castle Ojstrica by Vransko).

Anselm Design (* 1699 Amberg; Augustinian; † 17. December 1772 Enseldorf).

Charles-Bernard Désormes (* 1777 Dijon; † 1862 Verberie).

César Mansuète Desperetz (* 1792; † 1863).

Desprez (Duprez, Du Prez), French priest, flourished 1773-1775 in France.

Jean-Philibert Dessaignes (* 1762 Le Puy-en-Velay; † 1832 Vendôme in central France).

Georges Destriau (* 1903 Bordeaux; † 1960 Paris).

Andrej Detela (* 1949 Ljubljana).

Frančiška married de Toni (* 1859).

Snegulka Detoni married Moljk (De Toni, * 1921 Begunje by Cerknica; † 2016 Ljubljana).

Toni de Toni (Anton, * 1884 Cerknica).

Vincenc de Toni (* 1851 Trelli near Paularo (Paulâr) in Friuli; † 1907 Begunje no. 24, later no. 39).

Vincenc de Toni (* 1899).

Johann Deutz (Jean, * 29 November 1618; † 1673).

Arthur Devis (* 1712; † 1787).

Helen Rose née Banks married Dewar (* abt. 1849; † 1935).

James Dewar (* 1842; † 1923).

Karl Dežman († 11 March 1889).

Serafina Dežman (Serafine, * 29 September 1822 Idrija; † 1896 Ljubljana Prečna ulica no. 6).

Auguste Franziska Dick (née Kraus, * 1910; † 1993 Vienna).

Charles Scott Dickson (* 1850 Glasgow, Lanarkshire, Scotland; † 1922) brother-in-law of James Dewar.

Ernest Charles Scott Dickson (* 1889; † 1944) nephew of James Dewar as a son of Charles Scott Dickson.

William Kennedy-Laurie Dickson (* 1860 Le Minihic-sur-Rance, Brittany, France; † 1935 Twickenham, Middlesex, England) a Scottish inventor who designed an early motion picture camera.

Henry Winram Dickinson (* 1870 Ulverston, Lancashire; † 1952).

James Douglas Hamilton Dickson (* 1849 Glasgow; † 1931), brother-in-law of James Dewar.

Max Dieckmann (* 1882 Herrmannsacker by Stolberg (Harz); † 1960 Gräfelfing).

Bernard Diestel (* 1623 Vipava; SJ; † 1660 China).

Archbishop Cardinal Franciscus de Dietrichstein († 1636).

David L. DiLaura (* abt. 1948), Illuminating Engineer, taught architectural engineering at University of Colorado in Boulder in 1984-2007.

Karl Dillherr (Karel Dillher, * 1710 Vienna; SJ; † 1778 Stein by Krems).

Gjuro Dimić (Ђуро Б. Димић, † February 6, 1935 Beograd).

Milan Sergijević Dimitrijević (Милан С. Димитријевић, Sergije, * 1947 Leskovac (Лесковац), Serbia).

Vigilije Dinarić (Vigilij, Vigilio Dinarich, * 1711; † 1 April 1756 Bribir).

Yiwei Y. Ding (* 1963), studied at Iowa State University in 1988-1993, worked for Monsanto in 2008-2015, later became an Ag Formulation Chemist at Nestlé Purina North America, Consumer Goods, St. Louis, MO.

Johann Gottfried Dingler (* 1778 Zweibrücken; † 1855 Augsburg).

Emil Maximilian Dingler (* 1806 Augsburg; † 1874 Augsburg).

Alfred Dinsdale (Dinny, * 1896; † 1974 Pompano Beach, Broward County, Florida).

Anton Krištof Dinzl von Angerburg († 1727).

Janez Adam Gottfried Dinzl von Angerburg (* 9 November 1720 Zgornje Perovo).

Élie Diodatius (Elia, Elias, * 1576; † 1661).

Gennadij Gerasimovich Diogenov (Геннадий Герасимович Диогенов, * 1914 village Ново-Займское, Ялutorовский уезд Тобольской губернии (Yalutorovsky Uyezd of the Tobolsk Governorate of the Russian Empire); † after 1990), obtained his PhD in chemistry in Irkutsk in 1951.

Paul A. M. Dirac (* 1902; † 1984).

Eulogius Dirmhirn (* 1823 Schärding; † 1887).

Padanius Discorides (Πεδάντιος Διοσκοουρίδης, * about 40 Cilicia in modern Turkey; † 90).

Frank Dittmann (* 1960 Leipzig) curator at the Deutsches Museum in Munich since 2005.

Jan Długosz (Ioannes, Joannes, Johannes Longinus, Dlugossius, * 1 December 1415; † 19 May 1480).

Joseph William Doane (Bill) received his Ph.D. in Physics from the University of Missouri-Columbia in 1965 when he became a member of the Kent State University. In 1983 he became director of the Liquid Crystal Institute there.

Jakob Joannes Wenceslaus Dobrzensky de Nigro Ponte (Jakub Jan Vaclav (Wenčeslav) from Černeho Mostu (Schwartzbrug), * 1623; † 1697).

Cornelio August Doelter (Doelter y Cisterich, * 1850 in Arroyo (Puerto Rico); † 1930 Vienna) mineralogist, petrographer and chemist, professor in Vienna as replacement of Gustav Tschermak in 1907-1921.

Daro Dolar (Davorin, * 1921 Kranj; † 2006).

Jaro Dolar (* 1911 Maribor; † 1999 Maribor) librarian and poet.

Mladen Dolar (* 1951 Maribor) a Slovene philosopher, psychoanalyst, cultural theorist, and film critic as Jaro's son.

Sašo Dolenc (* 1973 Ljubljana).

Igor Dolgachev (Dolgačev, Игорь Владимирович Долгачев, * 1944 Moscow) a professor of algebraic geometry at Michigan University since 1978.

Karl Dollenz (Dollenc, Dolenz Károly, * 1703 Graz; SJ 1720 Graz; † 1751 Buda) of Carniolan origin according to Marko Pohlina and by Pohlina's data August Dimitz.

Jurij (Georg) Dolinar (* April 19, 1764 Vovče in Poljane valley; † 21 October 1858 Ljubljana).

Tomaž Dolinar (Thomas Dolliner, * 1760 Dorfarje pri Škofji Loki (Dörfern bei Altlack); † 1839 Vienna).

Janez Dolinšek (* 1957 Ljubljana).

Joseph Dollhopff (Dolhopf, * 1717 Vienna; SJ 1732 Vienna; † 1775/1800).

John Dollond (* 1706; † 30 November 1761).

Karl Domalip (Domalíp, * 1846; † 1909).

Josip Franjo Domin (Iosephi Francisci Domin, * 1754; † 1819).

Fran Dominko (* 1903 Vodnjan by Pula; † 1987 Ljubljana).

Vitalian Donati (* 1717, Padova; † 1762).

archbishop of Genoa Giovanni Stefano Donghi (* 1608 Genoa; † 1669 Rome).

Jean-Jacques-Daniel Dony (abbé Dony, * 1759 Liège; † 1819).

Johann Gabriel Doppelmayr (Doppelmeier, * 27 September 1677 Nurnberg; † 1 December 1750 Nurnberg).

Christian Doppler (* 1803; † 1853).

Natalis Doreguzzius (Natale Doregucci), editor and author in Bologna in 1682-1684.

Andrija Dorotić (Andrea Dorotich, baptized Stjepan, * 25 October 1761 Sumartin na Braču (on island Brač); OFM 1785 Ferrara?; 4 September 1837 Sumartin na Braču).

Remigio Samuel Döttler (Remigius, * 7 August 1741 Vienna; Piarist; † 8 April 1812).

Paul Mead Doty (* 1 June 1920 Charleston; † 2011).

Heinrich Wilhelm Dove (* 1803; † 1879).

Ivan Lovro Dragančić von Drachenfeld, probably a son of the ship-captain from Senj.

Henry Draper (* 1837; † 1882).

John William Draper (* 1811 Liverpool; † 1882 New York).

Cornelis Jacobszoon Drebbel (Drebel, * 1572; † 1633)

Camille Edouard Dreyfus (* 1878 Basel; † 1956 Manhattan, New York).

Mildred Dresselhaus (née Spiewak, * 1930 Brooklyn, New York; † 2017 Cambridge Massachusetts) a daughter of Polish Jewish immigrants, the "queen of carbon science",

nanotechnologist, the Professor Emerita of physics and electrical engineering at the Massachusetts Institute of Technology.

Paul Karl Ludwig Drude (* 1863; † 1903)

Thomas Drummond (Drumond, * 1797; † 1840).

Raphaël Dubois (* 1849 Le Mans; † 1929).

René Jules Dubos (* 1901 Saint-Brice-sous-Forêt, France; † 1982 New York), microbiologist at the Rockefeller Institute for Medical Research, later renamed the Rockefeller University in New York.

Louis Jules Dubosq (* 1817; † 1886 Paris).

Ferdinand Duchach (Duhač, † 1887).

Charles Benjamin Dudley (* 1842 Oxford, New York; † 1909 Pennsylvania).

Jean Ferapie Dufieu (* 1737; † 1769).

Dominicus Dufort (* 1753).

Corrine Dufour, American inventor from Savannah in Georgia.

Louis Dufresne (* 1890 Bourg-en-Bresse), French car designer.

Nicolas Lenglet Dufresnoy (* 1674; † 1755).

Laurentius Duhan (* 1656 Chartres; † 1726 Verdun).

Henri-Louis Duhamel du Monceau (* 20 July 1700 Paris; † 13 August 1782 Paris).

Jean Marie Constant Duhanel (* 1797 Saint-Malo; † 1872 Paris).

Eugen Dühring (* 1833; † 1921).

Karl Duisberg (* 1861; † 1934).

Pierre Louis Dulong (* 1785; † 1838).

Jean Baptiste André Dumas (* 1800; † 1884).

Johann baron Dumreicher (* 1815 Trieste; † 1880 castle Janušovec northwest of Zagreb near Slovenian border).

Henry Harrison Chase Dunwoody (* 1842 Highland County, Ohio; † 1933 Interlaken, New York), Brigadier General meteorology expert, after his retirement in 1904 vice president of the DeForest Wireless Telegraph Company.

Sebastian Dupasquier (Sébastien, Sebastianus du Pasquier, * abt. 1630; OFMconv Saint Bonaventure province of Lyon; † 1718).

Heinrich Jakob Karl Durege (Durège, * 1821; † 1893).

François Dussaud (Franz, Frantz, * 1870 Stäfa in canton Zurich (or Geneva); † 1953 Paris), private docent at chair in physics and chemistry at the Ecole de Mécanique in Geneva, after resettlement to Paris in 1896 established Dussaud company in 1907.

Saul Dushman (* 1883; † 1954)

Louis Dutens (* 1730 Tours; † 1812 London).

Guillaume Duval (Guglielmo du Val, Guillelmus, * about 1572 Pontoise 25 km northwest of Paris; † 1646 Paris).

Freeman John Dyson (* 1923 Crowthorne, United Kingdom; † 2020, Princeton, New Jersey).

James Dyson (* 1947 Cromer, English county of Norfolk).

Otto Dziobek (* 1856 Frankfurt an der Oder; † 1919 Berlin).

Dzou Yen (Zou Yan, Tsou Yen. 鄒衍, * about 305/340 B.C.; † 240/250).

E

George Biddel Eary (* 1801; † 1892).

Simon Eberle (* 1756; † 24 December 1827 Vienna).

Johann Jakob Ebert (* 1737 Wroclaw; † 1805).

Baron Moriz von Ebner-Eschenbach (* 1815 Vienna; † 1898 Vienna).

Michael Eckert (* 1949) studied physics at the Technical University of Munich and received his PhD in theoretical physics from the University of Bayreuth in 1979. Since 1981, he works at the Deutsches Museum in Munich.

Joseph Hilarius von Eckhel (* 13 January 1737 Enzesfeld bei Baden in Austria unter der Enns; † 16 May 1798).

Henry Turner Eddy (* 1844; † 1921).
Arthur Eddington (* 1882; † 1944).

Niels E. Edlefsen (* 1893 Cache, Utah; † 1971 Davis, Yolo, California).

Josef Maria Eder (* 1855 Krems; † 1944 Kitzbühel in Tirol).

Thomas Alva Edison (* 1847; † 1931).

Erik Edlung (* 1819; † 1888).

Prince Janez Ulrich Eggenberg (* 1568; † 1634)

Bernhard Béla Egger (* 1831 Buda; † 1910 Vienna).

Paul Ehrenfest (* 1880; † 1933).

Paul Ehrenfest (the son, * 1916; † 1939).

Felix Ehrenhaft (* 1879 Vienna; † 1952 Vienna)

Henry Ehrenreich (* 1928 Frankfurt; † 2008 Boston) as a Jew emigrated from Germany in 1938 to research at Schenectady, NY in 1955-1963. He became a trustee of the Dibner Institute for the History of Science and Technology, professor at Harvard and Director of Harvard's Materials Research Laboratory concerned about pollution and climate change, working on the science and the economics of alternative energy sources - especially solar and wind.

Julius Eibel (* 1843), on 31 October 1864 as supplementary teacher at the k.k. Higher Real School (Oberrealschule) in Klagenfurt came to Stockerau by Vienna as an associate teacher, tested for Higher Real Schools (Oberrealschulen). He taught arithmetic, geometry and geometric drawing in the man with his name lived in Vienna.

Georg Christoph Eimmart (* 1638; † 1705).

Andreas Einspieler (Andrej, * 1812 Suetschach in Rosental (Sveče in Rož) ; † 1888).

Albert Einstein (* 1879; † 1955)

Wilhelm Eisenlohr (* 1799; † 1872).

Daniel Ek (* 1983).

Johann Michael Ekling (Eckling, * 1795 Vienna; † 1876 Vienna).

Alfred Ekström (* 1873 Viksta parish, Uppsala county; † 1947 Botkyrka parish).

Johannes Elephantutius (Giovanni Scipione Elefantuzzi, Fantuzzi, † 14 November 1648).

Leonard Eleršek (* 1968 Zadar) colonel and engineer of Croatian air forces.

Don Fausto d'Elhuyar (* 1755; † 1833).

Heinrich Oscar Günther Ellinger (* 1857 Copenhagen; † 1947).

sir Charles Drummond Ellis (* 1895 Hampstead; † 1980 Cookham).

Walter Elsasser (* 1904 Mannheim; † 1991 Baltimore)

Julius Elster (* 1854; † 1920)

Anton Elšnik (* 1827 Sv. Jurij (St. Georg) in Slovenske Gorice).

Anton Elschnig (* August 22, 1863 Lipnica (Leibnitz) in Styria; † 1939).

Fritz Emde (* 1873 Uszyce in Śląsk (Silesia); † 1951 Stuttgart).

Karl George Emeleus (* 1901; † 1989).

August Hugo Emsmann (* 1810; † 1889).

Frederick William Engdahl (* 1944 Minneapolis), the conspiracy theorist based near Frankfurt on Main.

Victor Josef Karl Engelhardt (* 1866 Vienna; † 1944 Berlin).

Angelo Engelmayr (Engel Englmayr, Angelus, OFMobs in Austrian province St. Bernardin), flourished 1735-1745, general lector of theology and guardian of Franciscan monastery Eggenburg (Egenburg) in northern Lower Austria at least in 1743-1745, his works reprinted up to 1770.

Jožef Matija Engstler (* 1723 Oed in Lower Austria; SJ 1740 Linz; † 1811 Vienna).

Friedrich Franz Edler von Entnersfeld (Friedrich Entressfeld, Entnersfels, Entersfeld, * 1731 Vienna; † December 6, 1797 Vienna).

Franz Xaver Epp (* 1733; † 1789).

Anton Erberg (Franz Ksaver, * October 21, 1695 Dol by Ljubljana; † 3 October 1746 Ljubljana)

Bernard Ferdinand Erberg (* 1718; † 1773).

Ferdinand Benedict Gabrijel Erberg (* 1722; † 1796).

Franc Borgia Karel Erberg (* 1736; SJ 1752; † 1800).

Franz Michael Baron Erberg (* 1679; † 1760).

Innocent Erberg (* 1694; † 1763).

Janez Daniel Erberg (* 1647; † 1716).

Janez Jožef Lucius Erberg (* 11 February 1712 Ljubljana; SJ 18 October 1732 Vienna; † 29 June 1787 Dol).

Josef Kalasanc Ferdinand Avgustin Erberg (* 1771; † 1843)

Lenart von Erberg (Leonard Verderber, * 1606; † 1691 Kočevje).

John Ericsson (Johan, * 1803 Långban v Värmlandu na Švedskem; † 1889 New York).

Baroness Margareta Felicita Henrieta Erberg (* 1764 Ljubljana; † 1851 Ljubljana).

Maria Anne Elizabeth Erberg (* 1710; † 1752).

Susana Elizabeth baroness Erberg (* 1681 Ljubljana; † 1725).

Volbenk Daniel Erberg (* 1713; † 1783).

Marie-Thérèse de Palffy Erdödy (* 1719; † 25 December 1771).

Count Karl Paul III Palffy Erdödy (* 1697; † 1774).

Lennart Eriksson (* 1938; † 2014)

Emil Erlenmeyer (* 1825; † 1909).

Paul Erman (* 1764; † 1851).

Joseph Ermens (Jozef, * 1736; † 1805).

Ferdinand Ernecke (* 1832; † 1914).

Johann Christian Polykarp Erxleben (* 1744; † 1777).

Leo Esaki (江崎 玲於奈, Reona, * 1925 Osaka).

Johann Joachim Eschenburg (* 1743 Hamburg; † 1820 Braunschweig).

Gustav von Escherlich (* 1849; † 1935).

Josef Essl (* 1830 Berneck (Pernek); † 19 April 1874 Maribor).

Francesco III Maria D'Este (* 2 July 1698 Modena; † 22 August 1780 Varese).

Marie Beatrice Ricciarda d'Este, princess of Modena (* 7 April 1750 Modena; married on 15 October 1771; † 14 November 1829 Vienna).

Albert von Ettingshausen (* 1850; † 1932).

Andreas baron Ettingshausen (* 25 November 1796 Heidelberg; † 25 May 1878 Vienna).

Caroline Ettingshausen married Grailich (* 1835; † 1913).

Johan Albrecht Euler (* 1734; † 1800).

Leonhard Euler (* 1707; † 1783).

C. W. Francis Everitt (* 1934 Sevenoaks in Kent, UK).

Franz Serafin Exner (* 1849; † 1926).

Franz Exner (* 1802; † 1853), the father of the other three.

Karl Exner (* 1842 Prague; † 1914 Vienna).

Siegmund Exner (* 1846 Vienna; † 1926 Vienna).

F

Ruggiero Fabbri (Ruggero Fabri, * 1830 Ravenna; † aft. 1882 Ravenna).

Philipp Faber (Faventino, Fadentius, Filippo Fabri, * 1564 district Faenza Spinata di Brisighella; OFMconv 1582 Cremona; † 28 August 1630 Padova).

Vladislav Fabjančič (* 1894 Bučka by Škocjana and Raka; † 1950 Ljubljana).

Cornelia Fabri (Fabbri, * 1869 Ravenna; † 1915 Florence).

Honorat Fabri (Honoré, Honoratio Faber, Honoré Fabry, * 1606/07 Le Grand-Abergement between

Lyon and Grenoble (Virieux le Grand in Ain); SJ 1626 Avignon; † 1688 Rome).

Daniel Gabriel Fahrenheit (* 1686, Gdansk; † 1736 The Hague).

Richard B. Fair received his PhD at Duke University in 1969 to become a professor at Department of Electrical and Computer Engineering at Duke University, Durham, NC, USA.

Emanuel Fait (* 1854 Beroun (Verona, Beraun) 20 km southwest of Prague; † 1929 Prague).

Ignac Fajdiga (* 1850 Šentvid by Stična; † 1929 Kranj).

Isobel Jessie Falconer, former curator of museum at the Cavendish Laboratories turned historian of mathematics and physics at School of Mathematics and Statistics at North Haugh St Andrews southeast of Edinburgh in Scotland Coast.

Carl-Gunne Fälthammar (* 1931 Markaryd, Sweden) Professor Emeritus at the Royal Institute of Technology in Stockholm, Sweden where he succeeded Hannes Alfvén as Professor of Plasma Physics in 1975.

Ernest Faninger (* 1923 Maribor; † 2015).

Bertha Fanta (née Sohr, * 1865; † 1918).

Michael Faraday (* 1791; † 1867).

Michel Angelo Fardella (* 1650 Trapani, Sicily; † 2 January 1718 Naples).

Tomasso Fardella († 1694).

Moses Gerrish Farmer (* 1820 Massachusetts; † 1893).

Duke of Parma Ottavio Farnese (* 1524; † 1586).

Philo Taylor Farnsworth (* 1906 Utah; † 1971).

Barthélemy Faujas de Saint-Fond (Barthélmium, * 1741; † 1819).

Gerlinde Faustmann (* 1956).

Antonio Favaro (* 1847; † 1922).

Gustav Theodor Fechner (* 1801; † 1887).

Berend Wilhelm Feddersen (* 1832; † 1918 Leipzig).

Stuart Michael Feffer, professor at University of California, Berkeley, Center for Science, Technology, Medicine, & Society (CSTMS), Research Unit: Office for the History of Science and Technology.

Riccardo Felici (* 1819 Pisa; † 1902 S. Alessio in Lucca).

Anton Felkel (* 1740; † after 1798).

Arash Ferdowsi (* 1985).

Nicolo Fergolas (* 1753 Napoli; † 1824 Napoli).

Edvard Ferlinz (* 1817; † 1874).

Enrico Fermi (* 1901; † 1954).

Josef Anton Ferrari from Monza (da Monza, Giuseppe Antonio de Modoetia, OFMconv; † 1776 Monza?).

Richard Alan Ferrell (* 1926 Santa Ana; † 2005).

Friedrich Fessel (* 1821; † 1860).

Friedrich Wilhelm Feussner (* 1843; † 1928).

Joseph Louis le Fevre (Fèvre, * 1706 Nantes; SJ 1722; † 1780/1783 France).

Richard Phillips Feynman (* 1918; † 1988).

Leonardo from Pisa Fibonacci (* 1170 Pisa; † 1250 Pisa).

Johann Gottlieb Fichte (* 1762; † 1814).

Johann Ehrenreich von Fichtel (* 1732 Bratislava; † 1795 Sibiu (Sibinj, Hermannstadt, Nagyszeben, Cibinium) at Transylvania).

George B. Field (* 1929 Providence, Rhode Island).

Aleksandr Tichonovič Filippov (Александр Тихонович Филиппов, * 1936) worked in town of science (Naukograd) Dubna (Дубна) in Moscow region.

Nikolai Vasiljevič Filippov (Николай Васильевич Филиппов, * 1921 Moscow; † 1998 Moscow).

Sergeĭ Rostislavovich Filonovich (Sergei, Sergey Filonovič, Сергей Ростиславович Филонович, * 1952 Leningrad) later switched into management of business to become Dean of the Graduate School of Management of the National Research University Higher School of Economics in Moscow.

Josef Finger (* 1841; † 1925).

Rudolph Heinrich Finkener (* 1834; † 1902).

Bernard S. Finn (* 1932 Syracuse, New York).

Niels Ryberg Finsen (* 1860; † 1904).

Leonard Fioravanti (* 1518; † 1588).

Count Karl Joseph Firmian (* 1718; † 1782 Milan).

Emil Fischer (* 1852; † 1919).

Erhard Wolfgang Fischer (* 16 February 1929 Wiederau south of Leipzig; † 2011).

Johann Carl Fischer (Karl, * 1760 Allstedt (Thuringia); † 1833 Greifswald).

David E. Fisher (* June 22, 1932).

Marshall Jon Fisher (* 1963 Ithaca, New York), the son of David.

Sigmund Fischl (Siegmond Fischel, * 1847 Myslkovice (Miskowitz) in Tabor district of south Bohemia; † 1905 Prague).

George Francis FitzGerald (* 1851 Dublin; † 22 February 1901 Dublin).

Thomas Cecil Fitzpatrick (* 1866; † 1931).

Hippolyte Fizeau (1819 Paris–1896).

Gaius Valerius Flaccus (Valerio Flacco, * about 45; † about 90 AD.)

Dieter Flamm (* 1936 Vienna; † 2002) the son of Boltzmann's son-on-law Ludwig Flamm (* 29 January 1885 Vienna; † 4 December 1964 Vienna).

John Flamsteed (* 1646; † 1719).

Alexander Jürgen Flechsig (* 1984).

Werner Flechsig (* 1900 Cologne, Germany; † 1981 Wolfenbüttel) was Pohl's PhD student and assistant like Gudden.

Luise Fleck (Luise Kolm, Luise Kolm-Fleck, Louise Veltée, * 1 August 1873; † 15 March 1950).

Emil Fleischer (* 1843 Schwedt / Oder, † 1928).

John Ambrose Fleming (* 1849 Lancaster; † 1945).

Harvey Fletcher (* 1884; † 1981).

Dragutin Fleš (* 1921 Vukovar; † 2005).

Henry Albert Fleuss (* 1851 Marlborough in Wiltshire; † 1932).

Albert Fliegner (* 1842 Warsaw, Poland; † 1928, Lugano, Switzerland), replaced his teacher Zeuner as a professor of mechanics and engineering in ETH after Zeuner went to Dresden in 1872.

Francisco de Florencia (* 1619/20 Florida Espanola; SJ; † 1695 Mexico).

Ivan Dizma Florjančič de Griinfeld (Janez, Johann, * 1691; † ?1757).

Leslie Earl Flory (Les, * 1907 farm Sawyer in Kansas; † 2002), in 1930 joined RCA at Camden, NJ, then transferred to RCA headquarters in Princeton.

Etienne de Fodor (Étienne, István, * 1856 Bratislava; † 1929 Budapest).

Sigaud de la Fond (* 1730; † 1810).

Bishop of Porto José Maria Ribeiro Fonseca (da Fonseca de Évora, * 1690 Évora; OFM 8 December 1712 Rome; † 1752 Porto).

Charles Fontaine (* 1724; † 1802).

Hippolyte Fontaine (* 1833 Dijon; † 1910 Hyères on Mediterranean coast).

Pierre-Joseph Fontaine (* 1810; † 1877).

Felice Fontana (Felix, Felice Fontana (Felix, * April 15, 1730 Pomarolo near Rovereto in Tyrol near Rhône-Alpes, † 11 January 1805 Florence).

Bernard Le Bovier de Fontenelle (* 1657; † 1757).

George Forbes (* 1849; † 1936).

Henry Ford (* 1863; † 1947).

Lee de Forest (* 1873; † 1961).

Aimé Forster (* 1843 Beringen in Switzerland; † 1926 Bern).

Antonius Forti (* 1651 Caltagirone by Catania in Sicily; SJ; † 1707 Palermo).

Jean Nicolas Fortin (* 1750 Mouchy-la-ville (Oise); † 1831 Paris).

Léon Foucault (1819 Paris–1868 Paris).

Rayvon David Fouché (* 1969) director of American studies at Purdue university in USA.

A. Fournier professor of physics at lycée of the city La Rochelle in Charente-Maritime 30 km west of Surgères.

Georg Fournier (* 1595 Caen; SJ; † 13 April 1652 La Flèche).

George Fowler flourished in 1825-1852 in Paisley, Scotland.

Ralph Howard Fowler (* 1889 Roydon, United Kingdom; † 1944 Trumpington, Cambridge, UK).

William Alfred Fowler (* 1911 Pittsburgh; † 1995 Pasadena).

Robert Fox (* 1938 UK).

Samuel Fox, the husband of Erasmus's relative Anna Darwin.

William Darwin Fox (* 1805; † 1880) naturalist and a second cousin of Charles Darwin.

Girolamo Francastorio (Hieronymus Fracastorius, * 1478 Verona; † 1553 Calfi (Alfi) by Verona).

Louis-Benjamin Franceur's (Francoeur, * 1773 Paris; † 1849 Paris).

James Frank (* 1882; † 1964).

Philipp Frank (* 1884 Vienna; † 1966 Cambridge Massachusetts).

Usher Ionovitch Frankfort (Jewish Russian, Oucher, Ушер Ионович Франкфурт, * 1908 Proskuriv (Proskurov, today Khmelnytskyi (Проскуров, Хмельницький) in western Ukraine; † 1982 Moscow).

Edward Frankland (* 1825; † 1899).

Benjamin Franklin (* 1706; † 1790).

Rosalind Franklin (* 1920 west London; † 16 April 1958 southwest London).

Joseph Franko (* 1771; † 1842).

count Franjo Krsto Frankopan (* 1643; † 1671).

Nikola IV Frankopan (* 1393; † 1432).

Robert Franz grew up in East Germany and studied physics in Rostock and Luleå until 2003; he got his PhD in Materials Science from Montanuniversität Leoben in 2007. In 2011-2013 he joined his fellow East German André Anders's Plasma Applications

Group at Lawrence Berkeley National Laboratory and then returned to Leoben.

Claudio Frassen (Claude, * 1620/21 Peronna (Péronnas) in eastern France; OFM; † 1711 Paris).

Georg knight Frauenfeld (Ritter, * 1807 Vienna; † 1873) curator of Viennese museum, one of the leading scientists on board the Austrian frigate Novara during round-the-world voyage.

Joseph von Fraunhofer (* 1787; † 1826).

Walter Friedrich (* 1883 Salbke by Magdeburg; † 1968 Berlin).

Frederick Freksa (Friedrich, pseudonym of Kurt Friedrich-Freksa, * 1882 Berlin; † 1955 Berlin).

Jakov Pyich Frenkel (Yakov Il'ich, Яков Ильич Френкель, * 1894 Rostov on Don; † 1952 Leningrad).

Franciscus David Frescheur (Prescheur, * Cassel).

Sten von Fresen (* 1907 Uppsala; † 1996).

Carl Remigius Fresenius (* 1818 Frankfurt; † 1897).

Augustin-Jean Fresnel (* 1788; † 1827).

Ernest Freyer (Ernst, * 1729 Žatec (Saaz, Satz) near Ohr in the Sudetenland; † 1795 Idrija No. 136).

Henrik Freyer (* 1802; † 1866).

Robert Douglas Friedel (* 1950 Birmingham, Alabama)

Walter Friedel flourished as Patent office (Patentamt) employee and counsellor in Berlin in 1925-1931.

Francis Lee Friedman (* 1918 New York; † 1963 Boston).

Jakob Friedrich Fries (* 1773; † 1843 Jena).

Karl Friesach (* 1821; † 1891).

Otto Robert Frisch (* 1904; † 1979).

Nikodem Frischlin (* 22 September 1547 Balingen; † 29 November 1590 Hohenurach in Württemberg).

Paolo Frisi (* 1727; † 1784).

Gemma Frisius (* 1508; † 1555).

Felix Fritz, diploma engineer, researched oils as well as colours in Trieste in 1914, later in Eltville am Rhein in Hessen in 1937-1938.

Johann Friedrich Fritze (* 1735 Magdeburg; † 1807 Berlin), a Protestant physician.

Andrej Friz (Andreas, * 1711 Barcelona; SJ; † 1790 Gorizia).

Filip Fröhlich (* 1826 Metlika; † 1869 Ljubljana).

Erasmus Frölich (Fröhlich, * 1700, Graz; SJ; † 1758, Vienna).

Gaspar de la Fuente (Caspar Toletanus (Toledo in central Spain), * about 1596; OFMobs; † 1665).

Scottish-born Elisabeth Fulhame (* before 1764 Scotland; † after 1810).

Irish-born Thomas Fulhame (* before 1760 Ireland; † after 1800 Edinburgh?).

Robert Fulton (* 1765; † 1815).

Anton Funtek (* 1862 Ljubljana; † 1932 Ljubljana), Editor of *LZg* in 1895-1918.

Michael Furter (* Augsburg; † 10 November 1516/ 2 May 1517 Basel).

G

Mathias Gabler (* 1746; SJ; † 1805).

Dennis Gabor (Günszberg Dénes renamed Gábor in 1902, * 1900 Budapest; † 1979 London).

Aleš Gabrič (* 1963 Ljubljana).

Franz Charles Gabriel (* 1790; † 1858).

Max Paul Wolfgang Gaede (* 1878; † 1945).

Johann Gottlieb Gahn (* 1745; † 1818).

Pavao Gajić (* 1923).

Oscar Gale (* 1903; † 1998).

Domenico Gusmano Galeazzi (Galeati, * 1686 Bologna; † 1775 Bologna).

Joseph Galien (Gallien, * 1699/1700 Saint-Paulien in France; Dominican; † 1762/82 Avignon).

Franc Galilei (* Florence; † before 17 June 1647).

Galileo Galilei (* 1564; † 1642).

Mary Celeste Galilei (* 16 August 1600 Padua; † 16 February 1634 Florence).

Roberto Galilei (* 1595 Florence).

Roberto Galilei (* 1615 Florence; † 1681 Ljubljana).

wife Sidonia Victoria Baroness Mordax married Galilei (* 1624; † 1665 Ljubljana).

Theophilus Gallaccini (* 22 September 1564 Siena; † 27 April 1641 Siena).

Ludwig von Gallenfels (Ludovico, Golnik, baptized Johann Jakob on 14 December 1662; OFMobs; † 22 February 1728 Kamnik).

Evariste Galois (* 26 October 1811 Bourg-le-Reine by Paris; † 31 May 1832 Bourg-le-Reine).

Luigi Galvani (* 1737; † 1798).

Pio Riego Gambini (* 1893; † 1915).

Revaz Valerianovic Gamkrelidze (Гамкрелидзе, Ревáz Валериáнович Гамкрели́дзе, * 1927 Kutaissi (Кутаиси) in Georgia) Georgian-Soviet mathematician of optimal control theory and related fields.

George Gamow (Georgy Antonovich Gamov, Геóргий Анто́нович Га́мов, * 1904 Odessa; † 1968 Boulder, Colorado).

Sigmundus Gandin de Lilienstein (Andrej, * Hrib (Obergörtschach) along the Lake Črnava by Preddvor, † 1791).

Adolphe Ganot (* 1804; † 1887 Paris).

Ábrahám Ganz (Abraham, * 1814 Unter-Embrach in Switzerland; † 1867 Pest).

Nicholas II Garai (Nicolaus de Gara, II Garai Miklós, Nikola II Gorjanski, * 1367; † 1433).

Pius Nikolaus von Garelli (* 10 September 1675 Bologna; † 21 July 1739 Vienna).

André-Jacques Garnerin (* 1769; † 1823).

Jože Gasperič (* 1932 Ljubljana; † 2019).

Pierre Gassendi (* 1592; † 1655 Paris).

John Peter Gassiot (Gassiott, * 1797 London; † 1877 Ryde at the northeast of Isle of Wight).

Carl Gassner (*1855 Mainz; † 1942), practical physician in Mainz.

Pavel Gašperšič (* 1601; SJ; † 1672).

Bill Gates (* 1955).

Antoine Gaubil (Gobil, Gaubille, Sun Kiun-Yong, Song Junrong Qi Ying, Sun Kiun-yung, 宋君榮, * July 14, 1689 Gaillac in Languedoc; SJ September 13, 1704 Toulouse; † July 24, 1759 Beijing).

Antoine Gaudron (* 1640; † 1714).

Jean Motthé Gaugain (Jean-Mothee, * 1810 Sully in Calvados in Normandy; † 1879/80 St. Martin d'Estreaux near Bayeux).

Johann Carl Friedrich Gauss (* 1777; † 1855).

Pierre Gautruche (Peter Galtruchius, Pierre Gaultier,

Gaultier of Orléans, Gaultier Orléanois, Gaultier de Rome, * 1602 Orléans; SJ 1621 Orléans; † 1681 Caen).

Jean-François Gauvin (* 1969) curator at Harvard University.

Jules Gavarret (Louis Denis, * 1809; † 1890).

Louis Joseph Gay-Lussac (* 6 December 1778 St. Léonard in Limousin; † 9 May 1850 Paris).

Anton Geba (* 1860; † after 1901).

Franz Geba (Fran, * 1823; † after 1881).

Josef Geba (* 21 February 1882).

Josip Geba (* 1854).

Marija married Geba (* 1818).

Keith Geddes published about the history of TV and wireless in 1976-1991.

Claude-Joseph Geffroy (* 1685 Paris; † 1752 Paris).

Johann Samuel Traugott Gehler (* 1751 Görlitz; † 1795 Leipzig).

Paul Gehne received his PhD with a dissertation about permanent magnets in Halle in 1908.

Meg Gehrts (* 1891; † 1966).

Ernest Peter Geiduschek (* 1928 Vienna).

Hans Wilhelm Geiger (* 1882 Neustadt an der-Weinstrasse; † 1945).

Josip Geiger (Gregorius Josephus, * 27 August 1812 St. Peter no 19; † 25 March 1893).

Maria Schnitzler married Geiger (* 1817).

Paul Harold Geiger (* 1896 Paris, Michigan; † 1954).

Friedrich Wilhelm Geissler (* 1818).

Heinrich Geissler (* 1814; † 1879).

Joseph Geist (* 1770 Vienna; † 1824 Graz).

Hans Friderick Geitel (* 1855; † 1923).

Hiraga Gennai (平賀源内, nicknamed Fūrai Sanjin, 風来山人, * 1728/29; † 1779).

Friedrich von Gentz (* 1764; † 1832).

Anton Genuensis (Genovesi, * 1713; † 1769 Napoli).

Cherubin Le Gentil (Chérubin, * Orleans; OFMCap; † 1697).

Johann Gottlieb Georgi (* 1729 Gryfice in Pomeranian north-western Poland; † 1802 Sankt Petersburg), botanist-geographer of Siberia.

Walter Gerber (* 1902 Bern; † 1986).

Ranieri Gerbi (* 1763; † 1839 Pisa).

Hellmut Georg von Gerlach (* 1866 Moczydlnica Klasztorna in Polish Silesia (Mönchmotschelnitz); † 1935 Paris).

Walter Gerlach (Walther, * 1889; † 1979).

Anton Werner Ernst Gerland (* 1838 Kassel; † 1910 Clausthal, Lower Saxony).

Lester Halbert Germer (* 1896; † 1971).

Franz Anton Gerstner (František, * 1796; † 1840).

Franz Joseph knight Gerstner (* 1756; † 1832).

Wilhelm Geys (Guilielmo, * Franconia (Franken) in Bavaria; OFMconv; † 1711 Valduna in Switzerland or in Austrian Vorarlberg).

bishop Bernhard von Ghellen (Gallen, Christoph Bernhard baron Galen, * 1606 Drensteinfurt; † 1678).

Jean Joseph Ghislain (* 1751 Salles by Chimay in Habsburg Belgium; Vincentian (Lazarist); † 1812 Beijing).

Nicola Gianpriami (Niccolò Gianpriamo, Gianpriami, * 1686 Aversa; SJ; † 1759 Napoli).

Josiah Willard Gibbs (* 1839; † 1903).

Jacques Gibelin (* 1744 Aix-en-Provence; † 1828 Aix-en-Provence), physician, librarian and translator.

Elizabeth Gibney, a senior physics reporter of *Nature*, also writing for *Scientific American*, *BBC*, and *CERN*.

Robert Bernard Gibney (* 1911 Wilmington, Delaware; † 20 May 1991 New Castle, Delaware).

Janez Nepomuk Giel (Giehl, Giell, * 16. May 1734, Leitha on the Hungarian bank of Leitha river; SJ 17 October 1753, Vienna; † after 1786).

Henri Giffard (* 1825; † 1882).

Ludwig Wilhelm Gilbert (* 1769; † 1824).

William Gilbert (* 1540; † 1603).

Hermann Gilhofer (* 1852; † 1913).

Charles Henry Gimmingham (* 1853; † 1890).

Franciscus Ginthör (Franciscus Gindhör, * 1714 Passau; SJ 1739 Passau; † 1774 Linz?)

Prince Bishop of Passau Joseph Anthony Gindhör (* 1713; † 1791).

Wilhelm Friedrich Gintl (* 1843 Vienna; † 1908 Prague).

Vitaly Lazarevich Ginzburg (Вита́лий Ла́заревич Ги́нзбург, * 1916; † 2009).

Vitale Giordani (* 1633; † 1711).

Christoph Girtanner (* 1760; † 1800).

Luigi Giusti (* 1709 Venice; † 1766).

John Hall Gladstone (* 1827; † 1902).

Gustave Glaser (Gustav Glaser de Cew), published in 1883-1909.

Karol Glaser (Karel Glazer, Karel Glaser, * 1845 Reka by Zgornje Hoče near Maribor; † 1913 Graz, buried in Zgornje Hoče).

Otto Glasser (* 1895 Saarbrücken; † 1964 Cleveland, Ohio).

Bruno Glatzel (* 1878 Berlin; † 1914 by Verdun).

Johann Rudolph Glauber (* 1604 Karlstadt; † 1668 Amsterdam).

Johann Gottlieb Gleditsch (* 1714; † 1786).

Wolfgang Gloede published in Germany in 1977-1986.

Joža Glonar (* 1885, Zg. Korena by Maribor; † 1946 Ljubljana).

Leopold Gmelin (* 1788; † 1853).

Johannes z Gmundenu (* 1380/83 Gmunden in Upper Austria; † 1442).

Laurentius Gobart (* 1656 Liège; † 1750 Liège).

Gerhart Goebel (* 1906 Köln (Cologne); † 1995 Darmstadt-Eberstadt), published on history of (German) television in 1950-1985.

Heinrich Goebel (Henry Göbel, * 1818 Springe of Lower Saxony in Germany; † 1893 New York).

Johann Wolfgang von Goethe (* 1749; † 1832).

Anton Gogala (* about 1789 Lesce by Bled; 1835 ennobled von Leesthal; † 9 October 1841 Trieste).

Christian Goldbach (* 1690 Kaliningrad (Königsberg); † 1764 Moscow).

Peter Goldmark (Péter Károly, * 1906 Budapest; † 1977).

Bertrand Goldschmidt (* 1912 Paris; † 2002 Paris).

Bernard Raphael Goldstein (* 1938), a historian of astronomy as professor emeritus at the University of Pittsburgh.

Eugen Goldstein (* 1850 Gleiwitz, today's Gliwice in Polish Silesia; † 1930).

Heinz Rudolf Friedrich Gollnow (* October 3, 1911; † 1995) after his PhD at Friedrich-Wilhelms-Universität Berlin in 1937 researched quadrupole moments of nucleuses for Hermann Schüler's Berlin-Dahlem group in 1938, joined Göttingen University astronomic observatory (Universitäts-Sternwarte zu Göttingen) in 1948-1950, and finally worked at Mount Stromlo Observatory of the Australian National University near Canberra after 1952.

Andreas Golob from Institut für Geschichte & Universitätsarchiv at Karl-Franzens-Universität in Graz, (Institute for History and archive of Graz University).

Gregor Golobič (* 1964 Novo Mesto).

Igor Nikolaevich Golovin (* 1913 Moscow; † 1997 Moscow).

Grant Kohn Goodman (* 1924 USA).

Robert H. Gordon residing at Beading, in the county of Berks, Pennsylvania in 1883.

Majnard Henrik of Gorizia (Gorica, * 1385; † 1426)

Peter Gosar (* 1923).

Antonio Lorenzo Gossetti (Gosselti, * Zadar; † 1895 Trieste).

Ivan Gošnjak (* 1909 Ogulin; † 1980 Beograd).

Johann Gottlieb (* 1815 Brno; † 1875 Graz).

Martin Gottscheer (Gottseer, * 1648 Kirchau locality in Warth in Alpine Upper Austria; SJ 1668 Leoben; † 1731 Graz).

Josef Stulla-Götz (* 1901 Vienna; † after 1972).

Maximilian Götzen (* 1723 Prague; SJ 1739 Vienna; † 1798).

Antoine Goudin (* 1639; Dominican; † 1695).

Jules-Antoine-René de la Gournerie (* 1814; † 1883).

Bruno Goussault (* 26 January 1942).

Alexandre de Gouvea (Gouveia, * 1731 Evora (Évora) in Portugal; OFM third order 1775; † 1808 Beijing).

Carolina Leopoldine Elisabeth Franziska Gozani (* 2 March 1815).

Eve Trockenbrot married Gozani (Eveline, * 1792; † 25 March 1872).

Ferdinand Gozani (Bartholomäus Felix Konrad baptized on 1 November 1819).

Franziska Marquise Gozani (Maria Agnes Elisabeth Gozana (Gozzani) de St. Georges, * 1824).

Guido Josef Fidelizs Vinzenz Gozani (* 5 April 1831).

marquis Johann Nepomuk Gozani (* 1782; † 18 June 1836).

Johanna Nep. Katharina Elisabeth Franziska Gozani (baptized on August 24, 1818).

Robert Jemison Van de Graaff (* 1901; † 1967).

Boris Grabnar (* 1921 Ljubljana; † 2003).

Boris Pavlovič Grabovski (Grabowski, Борис Пáвлович Грабóвский, * 1901 Tobolsk; † 1966 Frunze) 182

Leo Graetz (* 1856 Wroclaw; † 1941 Munich).

Ferdinand Graf published about Alpine botany in 1875-1886.

Thomas Graham (* 1805; † 1869).

Joseph Wilhelm Grailich (* 1829 Bratislava; † 1859 Vienna).

Zénobe Théophile Gramme (* 1826; † 1901).

Antoine Le Grand (* 1629 Douai; † 1699 London).

Abbé Guido Grandi (* 1 October 1671 Cremona; † 4 July 1742 Pisa).

Edward Grant (* 1926 USA).

Willem Jakob Storm van s'Gravesande (William, * 27 September 1688 Herzogenbusch; † 28 February 1742 Leyden).

Drago Grdenić (* 1919 Križevci; † 2018 Zagreb).

Igor Grdina (* 1965 Celje).

Ralph Greatorax († 1712).

Jean-Baptiste Willart de Grécouro (* 1684; † 1743).

George Green (* 1793; † 1841 Nottingham).

Joe E. Greene (Joseph, * 1944 Arcata 280 miles north of San Francisco).

William Greener († 1869) gun manufacturer in Newcastle-Upon-Tyne and after 1844 in Birmingham. Farther of William Wellington Greener (* 1834; † 1921).

Robert Philips Greg (* 1826 Manchester; † 1906).

Lavoslav Gregoréc (* 1839; † 1924).

Heinrich Greinacher (* 31 May 1880; † 1974).

Jacques Bretel de Grémonville (* 1625; † 1686).

Friedrich Albrecht Carl Gren (* 1760; † 1798).

Heinrich Friedrich Gretschel (* 1830 Prietitz near Elstra in Germany; † 1892 Freiburg, Switzerland).

Zaharias Greyl (Greil, † 1720/1721 Augsburg).

Christoph Grienberger (* 1564; † 1636).

Joseph Grim (Grimm, Grimb, * 1742/1744 Upper Styria near Leoben; SJ 1762 Trenčín; †) attended Grammar School in Leoben, Maribor grammar school professor already in 1779/80, taught rhetoric after 1796 and schoolmaster in 1806 until his retirement in 1812.

Pietro Grimani (* 1677 Venice; † 1752) Venetian doge in 1741.

Jacob Grimm (* 1785; † 1863).

Wilhelm Grimm (* 1786; † 1859).

Francesco Grisellini (* 1717 Venice; † 1783 Milano).

Lars Olai Grondahl (* 1880 Hendrum, Minnesota; † 1968).

Caspar Gabriel Grönin (Kaspar, * 1752 Wismar in then Sweden now north Germany; † 1799 Wismar).

Eugene P. Gross (* 1926 New York; † 1991 Boston).

Theodor von Grotthuss (* 1785 Leipzig; † 1822 Gedučiai in Lithuania).

William Robert Grove (* 1811; † 1896).

Anton Gruber (* 26 March 1750 Vienna; † 1819).

Gabriel Gruber (* 1740 Vienna; † 1805).

Johann Gruber (* 1623; † 1680)

Tobias Gruber (* 1744 Vienna; † 1806)

Mirjan Gruden (* 1910 Ljubljana; † 2001).

Johann August Grunert (* 1797 Halle, Saxony-Anhalt; † 1872 Greifswald, Vorpommern-

Greifswald), professor and editor of mathematical journals in Greifswald.

Wenzel J. Grünert was a certified high school teacher candidate and assistant at the German technical college (University) in Brno (Brünn) in 1872-1873, before they hired private docent Ignaz Wallentin. With the approval Moravian authorities Grünert joined the teaching staff of Brno Higher Grammar school in the second semester as a teacher candidate on March 4, 1873.

Alfonz Gspan (* 1904 Krško; † 1977 Ljubljana) historian of literature and librarian, the son of botanist-surveyor Alfonz knight Gspan (* 1878 Kostanjevica; † 1963 Ljubljana).

Nada Prašelj married to Alfonz Gspan (Nadežda, * 1927 Maribor; † 2009 Ljubljana) librarian and linguist.

Anna Guagnini of department of philosophy and communications at the University of Bologna

Ignazio Guarini (* 1676; † 1748).

Bernhard Gudden (* 1892 Beuel in Bonn; † 1945 Prague).

Otto Guericke (* 1602; † 1686).

Jacques-Casimir Guérinois (Jakob, * 1640 Laval (Cenomanensi) in western France; OP 1656; † 1703 Bordeaux).

Veremundus Gufl (* 1705; OSB; † 1761) the Benedictine in monastery Prüfing (Prüfening Abbey) in outskirts of Regensburg in Bavaria.

Charles Édouard Guillaume (* 1861 Fleurier in Switzerland; † 1938 Sèvres in France).

Jean Pierre François Guillot-Duhanel (* 31 August 1730 Nicorps by Coutances; † 19 February 1816 Paris).

Joseph Gundl (* 1710; SJ; † 1770).

Antoine Nicolas Guntz (* 1859; † 1935 Nancy).

Samuel Gunz (Leopold Gientz, Guentz, * 1782/1785 Prague).

Simon Gunz (Guntzhausen, * 1743 Augsburg; † 11 November 1824 Prague).

Vladimir Aleksandrovich Gurikov (Aleksandrovič, Владимир Александрович Гуриков) published in Moscow in 1983-2018.

Ronald Wilfred Gurney (Wilfrid, * 1898 Cheltenham in England; † 1953 New York).

Viktor M. Gusev (Виктор Михайлович Гусев, * 1919; † 1978).

Marija I. married Guseva (Мария Ильинична Гусева, * 1925 Нежин (Nizhyn) in northern Ukraine); † 2017).

Bartholomei Laurenço de Gusmão (* 1685 Santos; † 1724 Toledo).

Julius Franciscos Gusman (Gusmann, * 1702; OAug; † 1776).

Franz Güssmann (Güsman, Gusman, * 30 September 1741 Wolkersdorf in Lower Austria; SJ 1757 Vienna; † 28 January 1806 Seitenstettin).

Božidar Guštin (* 1912; † 1984).

Johannes Gutenberg (* 1398; † 1468).

H

Pieter Willem Haaijman (* 1913 Middelburg) obtained his PhD in Amsterdam on 10 July 1940.

Erich Habann (* 1892; † 1968).

Fritz Haber (* 1868 Wroclaw; † 1934 Basel).

Marsbed H. Hablanian (Марсбед Х. Хабланиан, * 1924 Ukraine) the expert employed at Varian Vacuum Products, Lexington.

Eleonora Maria Josefa Habsburg (* 1653; Polish Queen 1670; † 1697).

Ferdinand I Habsburg (* 1503; German Emperor 1556; † 1564).

Ferdinand I Habsburg (* 1793; Emperor 1835-1848; † 1875).

Ferdinand III Habsburg (* 1608; emperor in 1637; † 1657).

Ferdinand IV Habsburg (* 1633; † 1654).

Ferdinand Karl Anton Joseph Johann Stanislaus Habsburg, archduke of Austria, duke of Modena (* 1 June 1754 Schönbrunn; † 24 December 1806 Vienna).

Emperor Frederik III Habsburg (* 1415; † 1493).

Emperor Josef II Habsburg (* 1741; † 1790).

Leopold I Habsburg (* 1640; emperor from 1658; † 1705).

Empress Maria Theresia Habsburg (* 1717; † 29 November 1780).

Mary of Habsburg (* 1505 Brussels; † 1558 Spain) the Hungarian queen.

Maximilian I Habsburg (* 1459; † 1519).

Emperor Rudolf II Habsburg (* 1552; emperor in 1576; † 1612).

Crown Prince Rudolf Habsburg (* 21 August 1858; † 30 January 1889).

daughter of Josef II, Theresia Elisabeth Habsburg (* 20 March 1762; † 23 January 1770).

Balthasar Hacquet (* 1739/1745; † 1815 Vienna).

Dušan Hadži (* 1921 Timisoara; † 2019 Ljubljana).

Jovan Hadži (* 1884 Timisoara; † 1972 Ljubljana).

Ernst Bessel Hagen (Carl, * 1851 Königsberg (Kaliningrad); † 1923 Solln by München).

Jacob Eduard Hagenbach-Bischoff (* 1833 Basel; † 1910 Basel).

Otto Hahn (* 1879; † 1968).

Ana Haldane married Nuki (* 26 June 1936; † 2001).

Duncan Haldane (* 1951 London).

Euphemia Bell married Haldane (* 1851).

Frederick Paterson Haldane (* 24 May 1912; † 15 September 1983).

Heulwen Morgan married Haldane

John Burdon Sanderson Haldane (* 1892; † 1964).

John Stuart Haldane (* 6 December 1957; † 21 August 2000).

Roberto Haldane (* 1841).

Thomas Frederick Haldane (* 1839 Kran High Church Paisley Renfrew; † 1916 Paisley, Renfrewshire 10 km west of Glasgow near the airport).

Charles Nicolas Alexandre Haldat du Lys (* 1770; † 1852 Nancy).

Jean-Baptiste Du Halde (* 1674; SJ; † 1743)

Agnes Spiers married Halden (Speirs, * 1804 the Paisley in Renfrewshire West of Glasgow in Scotland; † 1887 Maryhill in Lanarkshire, today the southeast part of Glasgow in Scotland).

John Halden (* 1787 Scotland; † 1856).

Stephen Hales (* 1677; † 1761).

Edwin Hilbert Hall (* 1855; † 1938).

Howard Tracy Hall (* 1919 Ogden, Utah; † 2008 Provo, Utah).

Franz Halla (* 1884 Vienna; † 1971 Dörfel in Lower Austria).

Albrecht von Haller (* 1708 Bern; † 1777 Bern).

Abundius Hallerstein († 1768).

Alexander Hallerstein († 1804 Ljubljana).

Avguštin Hallerstein (* 1773 Ljubljana; † 1774 Beijing).

Janez Vajkard Hallerstein (Weikhard, * 1706; † 1780 Dol by Ljubljana).

Edmund Halley (* 1656; † 1742).

Wilhelm Hallwachs (* 1859; † 1922).

John Baptist du Hamel (Joannis Baptistae Duhamel, * 1624 Vire in northwestern Normandy; Oratorian priest; † 1706 Paris).

William Rowan Hamilton (* 1805; † 1865).

Johann Hammerschmied with PhD in medicine worked as a Cashier of Association for the dissemination of scientific knowledge (Cassevervalter der Verein zur Verbreitung Naturwissenschaftlicher Kenntnisse) in Vienna from 1872, Councilor of Accounts at the Agriculture Ministry in 1873-1888 (Rechnungsrat (Rechnungsrath) in Ackerbau Ministerium).

William Hampson (* 1854; † 1926 London).

Franjo Hanaman (* 1878 Denovac in the county of Županja; † 1941).

Ambros Godfrey Hanckwitz (* 1660 Köthen (Cöthen, Anhalt); † 1741 London).

Alois Handl (Aloiz, * 1837 Feldkirch, Vorarlberg; † 1915 Suceava in Bukovina, now Romania (or Czernowitz (Chernivtsi) in Ukraine) taught experimental physics at the Universities of Lvov, Theresian Academy of Wiener-Neustadt and at Chernivtsi as a rector in 1879-1880 and 1894-1895 until his retirement in 1906.

Alexius Meinong Ritter von Handschuchsheim (* 1853 Lvov; † 1920 Graz).

Gregor Hanner (* 20 August 1807 Vienna).

Duke of Brunswick-Lüneburg Johann Friedrich of Hanoverian House (Frederick, * 1625 Herzberg am Harz 90 km southeast of Hanover; † 1679 Augsburg).

King George III of Hanoverian House (* 1738; † 1820).

Nicholas Adolf Hans (* 1888 Russia; † 1969 Greater London, UK).

Christian Hantschk (* 1943 Vienna).

Harry Hansen (* 1884 Davenport, Iowa; † 1977).

Branko Hanžek (* 1957 Čakovec).

Danica Burg-Hanžel (* 1934 Tržec).

Jean Appier Hanzelet (* 1596; † 1647).

Robert Hare (* 1781; † 1858).

Gerhard Ernst Friedrich Harig (Garig, Герхард Э. Гариг (* 1902 Niederwürschnitz; † 1966 Leipzig).

William Draper Harkens (* 1873; † 1951).

Cardinal Archbishop Ernest Adalbert de Harrach (Arnošt Vojtěch hrabě z Harrachu, * 1598; † 1667).

Thomas Rajmund count Harrach (* 7 March 1669 Vienna; † 1742 Vienna).

Rom Horace Romano Harré (* 1927 Manawatu, New Zealand; † 2019), a New Zealand-British analytical philosopher and psychologist of scientific realism.

John Harrison (* 1693; † 1776).

Georg Philipp Harsdörffer (* 1 November 1607 Nurnberg; † 22 September 1658).

Franz Hartig (* 1758 Prague; † 1797 Dresden).

Bruno Hartman (* 1924 Celje; † 2011).

Edmund Newton Harvey (* 1887 Germantown, Pennsylvania; † 1959 Woods Hole, Massachusetts) collaborated with Alfred Lee Loomis in the invention of the centrifuge microscope.

William Harvey (* 1578; † 1657 London).

Hasashige Tanaka (田中久重, * 1799 Kurume; † 1881).

Lorenz Leopold Haschka (Haska, * 1749 Vienna; † 1827 Vienna).

Friedrich Hasenöhrle (* 1854; † 1915).

Eduard von Haschek (Hašek, * 1875 Vienna; † 1947 Vienna) after the Anschluss of 1938 got professional ban together with Hans Thirring and suffered the additional house ban.

Hashimoto Sōkichi (橋本宗吉, Naomasa, Tei; Hakubin, Hakukō, * 1763 Osaka; † 1836).

Hashimoto Takehiko (橋本毅彦, * 1957 Tokyo).

Georg H. Hass (* 1913 Hanau, Germany; † 2003) studied at Danzig Institute of Technology. On 1 May 1946 he joined US Army Night Vision Engineer Research and Development Laboratories at the Engineer Center Fort Belvoir Virginia.

Jean-Henri Hassenfratz (Hassenfratß, * 1755 Paris; † 1827 Paris).

Francis Hauksbee (Hawksbee, * 1660; † 1713).

Francis Hauksbee (Hauksbee, Hawksbee, * 1660 Colchester; † 1713 London).

Francis Hauksbee the nephew (* 1687; † 1763).

Herbert Aaron Hauptman (* 1917 New York; † 2011 Buffalo) Jewish physical and structural chemist at the Medical Foundation of Buffalo who shared the 1985 Nobel Prize in Chemistry.

Victor Hausmaninger (* 1855; † 1907).

Walter Norman Haworth (* 1883; † 1950).

Abbé René Just Haüy (* 1743; † 1822).

Franjo Ivan Havliček (* 3 December 1906 Moravska Ostrava; † 7 March 1971 near Novi Vinodolski in Dalmatia).

Jaroslav Havliček (* 1879 Garešnica southeast of Zagreb; † 1950 Zagreb).

Ivan Jožef Anton von Haymonn (Haymann, Haiman, Haymon, * 1722 Postojna; † 1799 Ajman's (Ehrenau) castle by Sveti Duh by Škofja Loka).

Hazama Shigomi (間重, * 1756; † 1816).

Harold Locke Hazen (* 1901; † 1980).

Karl Heider (* April 28, 1856; † 1935).

Benjamin Hederich (1675; † 1748).

Friedrich Franz Heinrich Philipp von Hefner-Alteneck (* 1845; † 1904 Biesdorf near Berlin), close aide of Werner von Siemens.

Georg Wilhelm Friedrich Hegel (* 1770; † 1831).

Johann Florian Anton Heidmann (* June 16, 1772, Jáchymov (Sankt Joachimsthal) in Bohemia near the border with Saxony; † December 7, 1855, Vienna).

Agnesa Arsenjewa married Heil (Агнеса Николаевна Арсеньева, * 1901; † 1991).

Oskar Heil (* 1908 Langwieden in western Germany; † 1994, San Mateo, California).

John Lewis Heilbron (* 1934 San Francisco, California).

Johann Christoph Heilbronner (* abt. 1706; † 1747).

Jean-Jacques Heilmann (* 1853 Mülhausen; † 1922).

Johann Heilmann (* 1771; † 1834).

Johann Jacques Heilmann (* 1822; † 1859).

Josua Heilmann (* 1796; † 1848).

Mathia Heimbach (* 1666 Euskirchen in North Rhine-Westphalia; SJ Köln; † 1747 Köln).

Placidus Heinrich (born Joseph Heinrich, * 1758 Schierling by Regensburg; † 1825 Regensburg).

Werner Heisenberg (* 1901; † 1976).

Josef Karl Hell (Jozef Karol Höll, * 1713 Štiavnické Bane; † 1789 Banská Štiavnica (Schemnitz)).

Josef Karl's farther Mathias Corvinus Hell.

Josef Karl's brother Maximilian Hell (* 1720; SJ; † 14 April 1792 Vienna).

Josef Karl's brother Ignaz Cornel Hell

Rudolf Hell (* 1901; † 2002 Kiel).

Alexander Julius Hellemans (* 1946 Belgium), a freelance science writer in Antwerp, Belgium, former Director (science writer) at Sussex scientific limited UK from 2010 to 2015.

Wilfried Heller (* 1903 Bad-Durkheim; † 1982 Huntington Woods suburb of Detroit).

Christoph Friedrich Hellwag (* 1754; † 1835).

Marcus Hellyer, received Ph.D. in the history of semi-military Jesuitical science at the University of California, San Diego, after 2008 he transformed in a senior research officer at Parliament House as a terrorism analyst focusing on defence economics and military capability of Australian Strategic Policy Institute (ASPI) in intelligence community in Canberra.

Georg Helm (* 1851 Dresden; † 1923 Dresden).

Anna von Helmholtz (née Anna von Mohl, * 1834 Tübingen; † 1899) scientific translator as a second wife of Herman von Helmholtz.

Herman von Helmholtz (* 1821; † 1894).

Francis Mercurius van Helmont (* 1614 Vilvoorde in Belgium; † 1698/1699 Cölln by Berlin).

Jan Baptist van Helmont (Joannes, * 1580 (1579 by Old Style) Brussels; † 1644 Vilvoorde).

Walter Matthias Hempel (* 1851; † 1916 Dresden).

Heinrich Heraeus (* 1861; † 1910).

Jürgen Heraeus (* 1936).

Reinhard Heraeus (* 1903; † 1985).

Wilhelm Heraeus (* 1860 Hanau; † 1948 Hanau).

Wilhelm Carl Heraeus (* 6 March 1827 Hanau; † 1904).

Wilhelm Heinrich Heraeus (* 1900 Hanau; † 1985 Hanau).

Marija Ana Countess Herberstein (* 1660; † 1726).

Siegmund (Sigismund) baron Herberstein (Žiga, * 23 August 1486; † 28 March 1566).

Sigmund Friderik baron Herberstein (* 1549; † 1620).

Josef Edler von Herbert (Joseph Herverth, Hervert, Herwerth, Baptized on 26 August 1725 in Klagenfurt St. Egid; SJ; † 18 March 1794 Linz or parish Wels-St. Stephan 20 km southwest of Linz in bishopric Linz).

baron Michael Herbert (Johann Herverth, Hervert, Herwerth).

Francesco Herbitz (Frančišek Borgia, * 1752/1753 Jesenice; † after 1809 Vienna).

Carl Hering (* 1860 Philadelphia; † 1926 Philadelphia).

Zlatko Herkov noble Prazmaj Unadolski (* 1904 Zagreb; † 1994 Zagreb) historian, metrology expert, and economist.

Joseph Herman of New York researched television for *American Telephone and Telegraph Company* in 1925 and published for *Nokia Bell Labs* in 1928.

Emil Herrmann (Hermann, Herrmann Emil Gusztáv, * 1840 Dognecsa in Hungary in present-day Romania; † 1925 Budapest), after studies at the Viennese Polytechnic and in Banská Štiavnica he became professor at Mining and Forestry Academy in Banská Štiavnica (Berg- und Forst Akademie in Schemintz) in Slovakia at then Hungarian part of Habsburgian monarchy in 1869, full professor in 1884 as well as Higher mining counsellor (Oberbergrath).

Sigismund Friedrich Hermsstadt (Herbstädt, * 1760 Erfurt; † 1833 Berlin).

Francisco Hernandez (* 1514 La Puebla de Montalbán, Toledo; † 1587 Madrid).

Hero of Alexandria (Ἡρώων ὁ Ἀλεξανδρεύς, Heron ho Alexandreus, * about 10 AD. Alexandria; † about 70 AD. Alexandria).

Edward W. Herold (* 1907; † 1993).

Gustav Ludwig Hertz (* 1887; † 1975).

Heinrich Rudolf Hertz (* 1857 Hamburg; † 1894 Bonn).

Johann Daniel Hertz (* 1693; † 1754).

Sir John Frederick William Herschel (* 1792; † 1871).

William Herschel (* 1738; † 1822).

Josef Hervert (* 1846; † 1883).

Frederick Augustus Hervey (* 1730; † 1803).

Albert Hess, the head of the electrochemical department of Schuckert & Co., after Schuckert's death renamed to EAG (Elektrizitätsaktiengesellschaft/Electricity Public Company) in Nuremberg.

Philipp Hess (* 19 January 1845 Prague; † 8 November 1919 or 1926 Vienna).

Victor Franz Hess (1883 Waldstein castle in Styrian Peggau-1964 Mount Vernon suburb of New York).

Wilhelm IV of Hesse-Kassel (* 1532; † 1592).

Johann Friedrich Christian Hessel (* 1796; † 1872).

J. Ferdinand Hessler (Heßler, * 23 February 1803 Regensburg; † 13 October 1865 Vienna).

Karl Heumann (* 1850 Darmstadt; † 1894 Zürich).

Georg Hevesy (* 1885; † 1966).

Peter Cooper Hewitt (* 1861 New York; † 1921 Paris).

Castul Hieber (* 1761 München; OFMobs 1780; † 18 August 1810 Ingolstadt).

Bryan Higgins (* 1737/41 Collooney in Sigo in Ireland; † 1818/1821).

David Hilbert (* 1862; † 1943 Gottingen).

Friedrich Hildebrandt's (* 1764 Hannover; † 1816 Erlangen).

John Hill (* 1714 Peterborough in Cambridgeshire; † 1775 London).

William Hill (* before 1780; † 1847).

Max Hinterwaldner (* 1844 Schwaz in Tyrol; † 1912).

Philippe de la Hire (* 1640 Paris; † 1718 Paris)

Johannes Hirn (Johan, * 1795 Porvoo between Helsinki and now Russian Vyborg (Wiburg); † 1858 as pastor in Rautalampi 500 km north of Helsinki and St. Petersburg).

Jakob Hirschler (* 1852 Bratislava).

Hugo Hirst (Hirsch, Lord Witton, * 1863 Altenstadt, Bavaria; † 1943).

Lester Larsen Hirst (* 1903 Utah; † 1963) of university of California at Berkeley, later Bureau of Mines in Washington DC.

Johann Wilhelm Hittorf (* 1824; † 1914).

Peter Jacob Hjelm (* 1746; † 1813).

Hoashi Banri (帆足萬里, * 1778; † 1852).

Thomas Hobbes (* 1588; † 1679).

Karl Hochenegg (* 27 October 1860 Vienna; † 6 February 1942 Vienna).

Franc Hočevar (* 10 October 1853 Metlika; † 19 June 1919 Graz).

Josef Höck (* abt. 1935), published about Carinthia beginning by his Salzburg PhD in 1966 until 2005.

Lillian E. Hoddeson (* 1940 New York City), obtained her Ph.D. in physics at Columbia University in 1966, taught history of science and technology at University of Illinois in Urbana attached to Fermi National Accelerator Laboratory.

Garry Hodes (* 1948) Professor Emeritus of Department of Materials and Interfaces at Sustainability and Energy Research Initiative (SAERI) at Weizmann Institute of Science.

Jean A. Hoerni (* 1925; † 1997).

Friedrich Hoffmann (* 1660; † 1742).

Josef Hoffmann (* 1854 Ptuj).

Walter Höflechner (* 1943 Celje (Cilli) in Slovenian Styria).

August Wilhelm von Hofmann (* 1818 Giessen; † 1892 Berlin).

Donatus Hofmann a Transfiguratione Christi Domini (Donat, * 1703 Lübschütz in upper Silesia; Piarist; † 1783).

Theodor Hoh (* 1828 Nurnberg; † 1888 Bamberg), professor of physics at Grammar School and Lyceum in Bamberg.

Ludwig Samuel Joseph David Alexander baron Hohenbühel Heufler zu Rasen und Perdonegg (* 1817; † 1885).

Carl Hohenegg (1860 Vienna-1942 Vienna).

Franc Jožef Hanibal Hohenwart (* 24 May 1771 Ljubljana; † 1844 Kolovec).

count Jurij II Sigmund Hohenwart (* 1713).

Sigmund Hohenwart (* 7 June 1745 Celje; † 1825 Linz).

Friderik Wilhelm I king of the House of Hohenzollern (* 1688; † 1740).

Paul H. Holloway, received his PhD at Rensselaer Polytechnic Institute in 1972, former president of AVS, the professor emeritus at Department of Materials Science and Engineering of Florida University, Gainesville where he taught after August 1983, also at Department of Materials Science and Engineering at the University of Tennessee, Knoxville in 1994. In 1995-2001 he patented for at Planar Systems Inc., 1400 NW Compton Drive, Beaverton, OR 97006 formed in 1983 as a spinoff from Tektronix.

Nick Holonyak, Jr. (* 1928 Zeigler, Illinois, U.S.) created the first visible LED as the son of Ruthenian immigrants from the areas of modern Ukraine.

Gilles Holst (* 1886; † 1968).

Wilhelm Holtz (* 15 October 1836 Saatel bei Barth in Mecklenburg; † 1913).

Ferdinand Holweck (Fernand-Hippolyte, * 1890 Paris; † 1941 Paris).

Roderick Weir Home (* 1939) Professor of History and Philosophy of Science at University of Melbourne from 1975 until his retirement in 2002.

Masujiro Honda (本田 増次郎, * January 15, 1866

Misaki-cho, Kume District, Okayama Prefecture, Japan; † November 1925) was a Japanese editor, secretary of Japan Society for Prevention of Cruelty to Animals (Tokyo); trustee of Nippon Club (New York); member of Peace Society Japan, American Peace Society and the Protestant Episcopal Church of Japan. Probably related to the Japanese botanist Masaji Honda (Masazi, 本田正次, Shoji, * 1897 Kumamoto; † 1984).

Peter Honti (* 1907; † 1981).

Robert Hooke (* 1635; † 1703).

Edmund Hoppe (* 1854).

William George Horner (* 1786 Bristol; † 1837).

August Friedrich Horstmann (* 1842 Mannheim; † 1929 Heidelberg).

Don Garzia dall' Horto (Orta, Huerto, * 1490 Portugal; † 1568/1570).

Ivan Horvat (Johann Baptist Horvath, Horváth, * 1732 Günz; SJ 1751 Trnava; † 1799 Pest).

Radoslav Horvat (* 1920 Bečej in Serbian Vojvodina; † 2004 Beograd).

Rudolf Horvat (* 1873 Koprivnica; † 1947 Zagreb).

Caspar Höschel (* 1744; † 1820).

Michael A. Hoskin (* 1930 London).

František Houdek (* 1847; † 1917).

David A. Hounshell (* 1950 USA).

Charlotte Rieffenstahl married Houtermans (* 1899 Bielefeld, Germany; † 1993 Northfield, Minnesota).

Friedrich Georg Houtermans (Fizsl, * 1903 Zappot by Danzig (now Sopot by Gdansk); † 1966).

Sonja Ana Hoyer (* 1945 Murska Sobota).

Pavlo Hrabovsky (* 1864 Pushkarne, Okhtyrka county, Kharkiv gubernia; † 1902 Tobolsk, Siberia).

Silvo Hrast (* 1921 Trieste; † 1999).

Michael Hube (Jan Michał, * 1737 Toruń (Thorn) in Northern Poland; † 1807 Potycz in east-central Poland).

Louis Hubin (* 1628; † 1703).

Franz Hübl, published in 1869-1888 as professor at Grammar School (Gymnasium) in then Habsburgian now Ukrainian Czernowitz (Chernivtsi).

Johann Hübner (* 1668; † 1731).

Eric Hückel (* 1896 Berlin; † 1980 Marburg).

Bishop of Abrincensis (Avranches) in Normandy Peter Daniel Huetius (Pierre Huet, * 1630 Caen; † 1721 Paris).

Maurice Loyal Huggins (* 1897 Berkeley; † 1981 California).

David Edward Hughes (* 1831 London; † 1900).

Howard Hughes (* 1905; † 1976).

Albert Wallace Hull (* 1880 Southington, Connecticut; † 1966 Schenectady, New York).

Gordon Ferrie Hull (* 1870 Garnet in Canada; † 1956).

Alexander von Humboldt (* 1769; † 1859).

David Hume (* 1711; † 1776).

Karl Hummel (Carl, * 1801 Šatov (Schattau) by Znojmo in southern Moravia on Austrian border; † 1879 Graz).

David Leonard Hurd, published in 1964.

Jan Hus (* abt. 1369; † 6 July 1415).

Captain Oliver George Hutchinson (* 1891 Belfast; † 1944).

James Hutton (* 1726; † 1797).

Christiaan Huygens (* 1629; † 1695).

Matija Hvale (Qualle, * about 1470 Vače by Litija (pri Litiji); † 1518 Vienna).

Godfrey M. Hyams (* 1859; † 1927).

Josef Hyrtl (* 1810 Eisenstadt (Železno) in Burgerland; † 1894 Viennese suburb).

I

Isaia Iannaccone (* Napoli), published in 1990-2021 as a resident of Brussels.

Sonja Ifko, professor at the Faculty of Architecture of Ljubljana University.

Sumio Iijima (飯島 澄男, * 2 May 1939 Saitama Prefecture).

Martin Ilkuš (Marcin Bylica, Martin Bylica, Marcin z Olkusza, * 1433 Olkusz (Illkuš, Illkuš); † 1493 Buda).

Maximus von Imhof (* 1758 Reisbach in Lower Bavaria; Augustinian 1780-1802; † 1817 Munich).

Pietro Imperati (OSM (*Servite* religious order); † 1605 Bologna).

Pierre Noël Chéron d'Incarville (* 1706; † 1757).

Jan Ingenhousz (Ingen Housz, * 1730 Breda in southern Netherlands; † 1799 Wiltshire).

Marek Inglot (* 1961 Poland; SJ) full professor at the Faculty of History and Cultural Heritage of the Church of the Pontifical Gregorian University.
George Elmer Inman (* 1895 Kenosha, Wisconsin; † 1972).

Pope Innocent XII (* 1615; † 1700).

Orlando Inwinkl (Inwinkel, * 1880 Barban (Barbana) in southern Istria; † 1936 Colombes in the northwest suburb of Paris).

Abundus Maria Inzaghi (Abondio, Abbondio, * Como; † 1691 Graz).

Franc Janez Nepomuk Count Inzaghi baron Kindberg (* 1734; † 1818).

Franz Anton Inzaghi (* 1719; † 1791).

William Irvin (1743; † 1787).

William Irvine (* 1743 Glasgow; † 1787)

William Irvine (* 1776; † 1811).

Paul B. Israel (* 1953 California).

Alexander Konstantinovich Ishkneli (Александр Константинович Ишкнели, * 1916) studied at Tbilisi University in 1937.

Jan Ivanchich (Ján Ivančič, Johan Ivancisc, * 1722 Komarno in Slovakia; SJ; † 1784 Trnava).

Radmilo M. Ivanković (Радмило М. Иванковић, * 1933 Batina (Kiskőszeg) in Croatian Baranja; † 2017 Beograd?).

Herbert E. Ives (* 1882 Philadelphia; † 1953).

Joseph Izarn (* 1766 Cahors; † 1834 Paris).

Anton Batista Izzo (* 1721 Košice; † 1793 Vienna).

J

Pavel Nikolaevich Jablockov (* 1847; † 1894).

Friedrich Heinrich Jacobi (* 1743; † 10 March 1819 Munich) the father of Maximilian Jacobi.

Maximilian Jacobi (* 1775; † 1858).

William White Jacques (* 1855 Haverhill, Massachusetts; † 1932).

Agatha Maria Jacquin (* 1735).

Joseph Franz Baron Jacquin (* 1766; † 1839).

Nikolaus Joseph Baron Jacquin (* 1727; † 1817).

Francisco Jacquier (* 1711 Vitry-le-François; OM; † 1788 Rome).

Karl von Jaeger (Jäger, * 1936 Carinthia; † 1920 Graz).

Gustav Jäger (* April 6, 1865 Krásná by Aš (Schönbach by Asch) in Bohemia; † January 21, 1938 Vienna).

Louis II Jagiełło (* 1506; † 1526 Mohács).

Władysław III Jagiełło (* 1424 Krakow; king of Poland and Hungary; † 1444 Varna).

Joseph Jagunić (* 1831 Plešivica in Croatia; † 1891).

Boris Jakobi (* 1801; † 1894).

Moritz Herman Jakobi (* 1801; † 1874).

Stjepan Jakšeković (* 1907; † 1985 USA).

Jean Jallabert (* 1712 Geneve; † 1768 Nyon in Switzerland near French border).

Catherine Jami (詹嘉玲, * 1961).

Gilles Celestine Jamin (Jules Célestin Jamin, J. Gamin, * 30 May 1818 Termes; † 12 February 1886).

Johann Jamnički (Jamnický, † 1881).

Darko Jamnik (* 16 July 1925 Toplice no. 50 near Zagorje by Sava river).

Anton Janežič (* 1828; † 1869).

Radoje Janković (* 1879 Čačak; † 1943).

Zacharias Janssen (Zacharias Jansen, Sacharias Jansen; * 1585 The Hague; † 1632/1638 Amsterdam).

Anton Jarányi (Jaránui, * 1725 Pécs; † 1797 Pécs).

Gabriel Jars (Antoine, * 1732 Lyon; † 1769 Clermont).

Simon Jarz (* 3 April 1842 Sankt Kanzian (Škocijan) no. 8 near Eberndorf (Dobrla vas) east of Klagenfurt).

András Jaszlinszky (Jaslinszky, * 1715 Szinna near Košice; SJ 1733 Košice; † 1784 Rozsnyó (Rosnaviae, Rožnava) in Bohemia).

George François Jaubert (* 1870 Geneva; † 15 February 1959 Chaville in Hauts-de-Seine of north-central France), doctor of science and inventor, chemistry preparer at École polytechnique, president of the Central Apiculture Society, editor the *General review of pure and applied chemistry* with 21 Parisian volumes published in 1899-1918.

Chrysostomus Javellus (Chrysostom Javelli Canapicus, Grisostomo Javelli, * about 1470/1472 San Giorgio Canavese (Canapicus) in Piedmont; OP 1485; † about 1538 Bologna or Piacenza).

Badī' az-Zaman Abū l-'Izz ibn Ismā'īl ibn ar-Razāz al-Jazarī's (بدیع الزمان أبو العز بن إسماعيل بن الرزاز الجزري) Jazari, * 1136 Mesopotamia; † 1206 Mosul).

Ányos István Jedlik (Štefan Anián Jedlík, Stephanus Anianus Jedlik, * 11 January 1800; † 13 December 1895).

Francis Jehl (* 1860 New York; † 1941 Florida).

Karl Jelinek (* 1822 Brno; † 1876 Vienna).

Marija Mira Jenčič married Samec (* Vienna; † 1911).

Salvislav Jenčič (* 1891; † 1968).

Sigmund Jencic (Jenčič, * 1679; † 1718).

Charles Francis Jenkins (* 1867; † 1934).

Bojan Jenko, received PhD under Paulin's supervision in Maribor in 1991.

Jožef Jenko (Josef, * 1776; † 1858).

Monika Jenko, wife of Bojan.

Edward Jenner (* 1749; † 1823).

Henning Højgaard Jensen (* 1918 Emb of Blistrup Parish on Mors; † 2001).

Franz Jeschowsky († 29 April 1814 Graz).

Heinrich knight Jettmar (* 1849 Lvov).

Karl Ježek (* 1851 Blansko; † 1919).

Richard Ježek (* 1860 Blansko; † 1948).

Numata Jirō (沼田次郎, * 1912; † 1994).

Jean-Baptiste-Ambroise-Marcellin Jobard (* 17 May 1792 Baissey in France; † 27 October 1861 Brussels).

Steve Jobs (* 1955; † 2011).

Abram Fedorovich Joffe (Ioffe, А.Ф. Иоффе, * 1880 Romny (Ромні) in northern Ukraine; † 1960 Leningrad).

Helmut Johannson († 1982).

Johann Friedrich John (* 1782 Anklam; † 1847 Berlin).

John Bertrand Johnson (* 1887).

Walther H. Johnson (Walt), the engineer working for KLA-Tecnor at Prometrix Corp. in Santa Clara, CA.

Henry Bence Jones (* 1813; † 1873 London).

Georg Jonke (* 1777 Gorenje (Oborn) No. 4 in Carniola; † 1864).

Johann Quentin I Jörger von Tollet (* 1624; † 1705).

Chandrasekhar "Chan" Janardan Joshi (* 1953 Wai, Maharashtra, India) did pioneering work in plasma-based particle acceleration techniques at UCLA for which he won the 2006 James Clerk Maxwell Prize for Plasma Physics.

Gregor Jotzu (* 1986 Bad Homburg, Germany), obtained Ph.D. in Physics at ETH in 2015.

Jules François Joubert (* 1834 Tours; † 1910 Paris).

Marquis Achille Jouffroy d'Abbans (* 1785; † 1859 Torino).

Marquis Claude de Jouffroy d'Abbans (* 1751; † 1832 Paris).

James Prescott Joule (* 1818; † 1889).

Branimir Jovanović (* 1955 Beograd).

Dragoljub Jovanović (* 1891; † 1970).

Johann Juncker (* 1679 Londorf; † 1759 Halle).

Christa Jungnickel (* 1935 England; † 1990) married to Russell McCormmach.

Anton Jungnitz (* 1764 Męcince (Hermannsdorf); † 1831 Wroclaw).

Josefine Jurik from Košaki north of Maribor (Leitersberg bei Marburg from 2008 part of Maribor city), as Catholic politician edited and published in 1880-1893 mostly in Maribor (Marburg) and in Slovenj Gradec (Windischgraz) in lower Styria.

Bernard Jussieu (* 1699 Lyon; † 1777 Paris).

Alexander Friedrich Just (Just Sándor Frigyes, * 1874 Bremen; † 1937 Budapest).

K

Boris Borissowitsch Kadomzew (Борис Борисович Кадомцев, Kadomtsev, * 1928 Pensa; † 1998 Moscow).

Georg Wilhelm August Kahlbaum (* 1853 Berlin; † 1905 Basel) chemist and historian of chemistry, younger son of the owner of chemical manufacture August Wilhelm Kahlbaum (* 1822; † 1884),

Dawon Kahng (* 1931 Seoul; † 1992 New Jersey).

Tiangong Kaiwu (* 1587; † 1666).

Rafael Kalish, former researcher at Laboratory for Nuclear Science at Massachusetts Institute of Technology in Cambridge, emeritus at Solid State Institute and Physics Department, Technion—Israel Institute of Technology in Haifa.

Heike Kamerlingh-Onnes (* 1853; † 1926).

Simon Kapferer de Lypnica, OFM, taught in Innsbruck college (in conventu ad S. Crucis) of Tyrolean Franciscan province in 1774-1778.

Pietro Kandler (* 1804 Trieste; † 1872 Trieste).

Hans Kangro (* 1916 Leipzig; † 1977 Bad Bevensen).

August Kann (* February 19, 1871 Vienna; † September 11, 1937).

Ana Mayer married Kansky (Anka, * 1895 castle Lože by Vipava; † 1962).

Evgen Kansky (* 1926 Ljubljana; † 1987).

Evgen Kansky (* 1887 Warsaw; † 1977).

Simon Kapferer (named by the Saint Simon of Lipnica Murowana by Krakow in Silesia, * 3 March 1752; OFM Hall in Tyrol 5 km east of Innsbruck; † 1824 as secular priest).

Pjotr Leonidovich Kapica (Kapitsa, Peter Kapitza, Пётр Леонидович Капица, * 1894; † 1984).

Jovo Kapičić (Капа, * 1919 Gaeta in central Italy south of Rome; † 2013 Beograd).

Heinrich Kappeller the younger inherited his firm from his father who established it in 1830s at Wien V Margareten, Franzensgasse 13 later also at V Bezirk Kettenbrückengasse 9 and in Budapest outpost to produce the clockworks, thermometers, and weather houses in 1850s-1913 by his Institut für physikalische und meteorologische Instrumente.

Johann Kapsch (Kapš, Kapsh, * March 1, 1845 eastern Kočevje areas of modern Slovenia (Unterlag

(Spodnji Log) no. 12, Graflinden (Knežja Lipa) or Uršna Sela southeast of Dolenjske Toplice); † September 28, 1921 Vienna).

Franciscus Xaverius Kareau (Karü, * 1731; † 1802).

Josef Kareis (* 1837 Semice (Semitz) in Bohemia; † 1913 Vienna).

August Karolus (* 1893 Reichen by Sinsheim, Germany; † 1972 Zollikon, Switzerland).

Franc Ksaver Karpe (Samuel, * 17 November 1747 Ljubljana; † 19 June 1806).

Abraham Gotthelf Kästner (* 1719 Leipzig; † 1800 Göttingen).

Karl Wilhelm Gottlob Kastner (* 1783; † 1857 Erlangen).

Marin Katalinić (* 1887 Trogir; † 1959 Skopje).

Michael Kauffer (* 1673; † 1756).

Walter Kaufmann (* 1871; † 1947).

Prince Wenzel Anton count Kaunitz-Rietberg (* 2 February 1711; † 27 June 1794).

Luise Ronsperger married Kautsky (* 11 August 1864 Vienna; † 8 December 1944 Auschwitz (Oświęcim)) the wife of Karl Kautsky (* 1854 Prague; † 1938 Amsterdam).

William Kay (* 1879; † 1961).

Heinrich Gustav Johannes Kayser (* 1853; † 1940).

Bartholomew Keckermann (* 1571/1573 Gdansk (Danzig); † 1609 Gdansk).

Bonifaty Mikhailovich Kedrov (Бонифатий Михайлович Кéдров, * 1903, Yaroslavl (Ярослáвль); † 1985 Moscow) joined the Bolsheviks in 1918 to become the philosopher, logician, chemist, psychologist. He criticized Stalinism and Khrushchev in 1956.

Fedor Borisovič Kedrov (Федор Борисович Кéдров, * 1912), after graduating from the Faculty

of Physics and Mathematics at the University he authored several biographical books about scientists and engineers: Rutherford, Frederic and Irene Joliot-Curie, Kapitsa, Frenkel, I.G. Alexandrov (Ив́ан Гаври́лович Алекса́ндров (* 1875; † 1936), В.Е. Ведене́ев (Борис Евге́ньевич Ведене́ев (* 1885 Tbilisi; † 1946 Moscow), etc.

William Andrew Keenan worked for EESPEC at Prometrix Corp. in Santa Clara, CA.

Friedrich Keesbacher (* 1831 Schwaz in Austrian Tyrol; † 1901 Ljubljana).

Willem Hendrik Keesom (* 1876 Texel; † 1956 Leiden).

John Keill (* 1671 Edinburgh; † 1721 Oxford).

Friedrich August Kekulé von Stradonitz (* 1829 Darmstadt; † 1896 Bonn).

Andrew Keller (* 1925 Budapest; † 1999).

David Kellner (* 1643; † 1725).

Paul Joseph Kelly (* 1915 Riverside, California; † 1995 Santa Barbara, California) the mathematician in Santa Barbara.

William Kelly (* August 21, 1811 Pittsburgh, Pennsylvania; † February 11, 1888) studied metallurgy at the Western University of Pennsylvania.

Sir William O'Kelly (Guillermo (Giulo, Guilelmi) O'Kelly, Hibernia, ex familia O'Kelliorum ab Aghrim, William O'Kelly of Aghrim, chevalier of the Holy Roman Empire, hereditary Lord of Culagh and Ballinahown, Count Palatine Imperial and Inspector of Arms of His Imperial Royal Majesty, * abt. 1670 Aghrim, county Galway; † 1751) studied humanities at Louvain University and philosophy at Paris. He settled in Vienna in 1698 as a friend and adviser to Emperor Leopold. His descendant Ludvik Mac Neven baron De Cranagh O'Kelly ab Aghrim (* 1795 Prague; † 1873 Ljubljana) as a District Chief in Postojna married Victoria Elizabeth Codelli at Kodeljevo Castle of Ljubljana on November 4, 1835.

William Thomson Kelvin (* 1824; † 1907), after the year 1892 Lord Kelvin.

Rankin D. Kennedy (* 1853/54; † 1917 Isle of Bute).

David T. Kenney (* April 3, 1866; † 1922) born in the family of Irish immigrants in the USA.

Johannes Kepler (* 1571; † 1630).

Stefan Keresztes (* 26 December 1600 Žitný Ostrov (Csallóköz) in Slovakia north of Győr; SJ).

Francizek B. Keri (Franc Borgia Kéri, Ferenc Kéry, * 1702 Kenyerkőe (Kenézlő) in Borsod-Abaúj-Zemplén County in northeastern Hungary; SJ 1719 Košice; † 1768 Trnava).

Johann Gottlieb Kern († 1775?).

John Kerr (* 1824 Ardrossan, Scotland; † 1907 Glasgow).

Anton Kerschel (Kršl, * 30 May 1790 Idrija; † 22 May 1847 Gorizia).

Janez Krstnik Kersnik (* March 26, 1783, Moste pri Žirovnici in Upper Carniola (Gorenjska); † 24 June 1850 Ljubljana).

Donald William Kerst (* 1911 Illinois; † 1993).

Robert Eugene Kerwin (* 1932 Wallaston, MA), member of the Technical Staff at Bell Telephone Laboratories from 1958 to 1967.

Ferenc Kéry (Kéri, Keri, Franc Borgia, * 1702 Kenézlő in northeastern Hungary; † 1768 Trnava).

Konrad Keyser (Conrad Kyeser, * 1366 Eichstätt in Bavaria; † after 1405).

Joseph Khell von Khellburg (* 1713 Linz; † 1772 Vienna).

Iosif Benzionovich Khriplovich (Иосиф Бенционович Хриплович, * 1937 Kiev).

Boštjan Kiauta (Bastian, * 1937 Ljubljana).
Ladko Kiauta (Ladislav, * 1914; † 1990).

Boris Kidrič (* 1912 Vienna; † 11 April 1953
Belgrade).

France Kidrič (* 1980; † 1950).

Franz Kiebitz (*1878 Bautzen in east Saxony; †
1962).

Jack StClair Kilby (* 1923 Missouri; † 2005 Dallas).

Philip Andreas Killian (* 1714 Augsburg; † 1759
Augsburg).

Edward Augustin King (* 1814 Cambridge,
Washington County, New York in USA; † 1863
battlefield of Chickamauga, Georgia in USA).

Kenneth Hay Kingdon (* 1894 Montego Bay in
Jamaica; † 1982 Schenectady).

Gottfried Aloys Kinner von Löwenturn (* 1610
Reichenbach, Silesia (now Dzierżoniów in
southwestern Poland); † after 1669 Prague?).

John Jervis Kipling published in 1964-1965.

Athanasius Kircher (* 2 May 1601/1602, Geisa; SJ
1618, Paderborn; † 1680, Rome).

Gustav Robert Kirchhoff (* 1824; † 1887).

Georg Caspar Kirchmaier (* 1635; † 1700
Wittenberg).

Richard Kirwan (* 1733; † 1812).

László Kiss (* 1950 Šahy (Ipolyság) in southern
Slovakia) district doctor in Čiližská Radvaň
(Csilizradvány) in the Trnava Region of south-west
Slovakia.

Erasmus Kittler (* 1852 Nurnberg; † 1929
Darmstadt).

Rudolf Kladnik (* 1933 Hrastnik; † 1995 Ljubljana).

Hendrik Anne Klasens (Klassens) obtained his PhD
at Groningen University in 1941 to work for Philips
Research Laboratories.

Johann Baptist Klauber (* 1712 Augsburg; † 1787).

Donald L. Klein (* December 19, 1930 Brooklyn,
NY), son of a Hungarian father and a Hungarian-
American mother.

Felix Klein (* 1849; † 1925).

Joseph Frederic Klein (* 1849 Paris; † 1918
Bethlehem, Pennsylvania), professor of mechanical
engineering at Lehigh University in Bethlehem as
Gibbs' friend.

Ludwig Kleinberg (* Boryslaw in western Ukraine;
† 1920 Vienna).

Andreas Kleinert (* 1940 Opole (Oppeln) in Upper
Silesia of south Poland).

Karin Stana Kleinschek obtained her PhD degree
from the Institute of Physical Chemistry of the
University of Graz, Austria in 1996.

Ewald Jürgens von Kleist (* 1700; † 1748).

Karl Klekler (* 1842 Wiener Neustadt; † after 1901).

Alfons Klemenc (* 1885 Spodnja Šiška by
Ljubljana; † 1960).

Ignac Klemenčič (* 1853; † 1901).

Peter Klinar (* 1934 Ljubljana; † 1994 Kranjska
Gora).

Pieter Frits Abraham Klinkenberg (* 1915
Amsterdam; † 2005).

Klaus von Klitzing (* 1943).

Aaron Klug (* 1926; † 2018).

Matej Daniel Kmet (Kmetch, * 1783 Brezno in
cenral Slovakia; Piarist; † 1825 Košice).

Josip Fran Knaflič (* 1879 Šmatno by Litija; † 1949 Ljubljana).

Baltasar Knapič (Balthasar, Baltazar Knapitsch, Knappitsch * 26 November 1848 Viktring (Vetrinj) no 18, southern suburb of Klagenfurt; † 14 April 1914 Schwimmschulkai no 6 north of Graz city center) published on chemical analysis of Carniolan waters in 1877-1893 in Ljubljana real school reports, retired as director of secondary school.

Sebastian Kneip (* 1821; † 1897).

Paul Knipping (* 1883; † 1935 Darmstadt).

Eberhard Knobloch (* 1943 Görlitz).

Gustav Knobloch flourished 1876-1907, then retired in Graz.

Max Knoll (* 1897; † 1969).

Martin Knudsen (* 1871; † 1949).

Andrej Kobav (Kobal, * 7/11 November 1591 or 1593 Cerknica; SJ 22 October 1610 Brno in Moravia; † 12 February 1654 Trieste (Trst)).

Matija Ahacel Kobentar (* 1779; † 1845).

Gvido(n) Kobencl (Guodobald Cobenzl, * 1716 Ljubljana; † 1797 Gorizia).

Janez Gašpar Kobencl (Cobenzl, * 30 May 1664/1669 Lože pri Vipavi; † 20/30 April 1742 Graz).

Count Janez Filip Kobencl (Cobenzl, * 1741, Ljubljana; † 1810).

Janez Karl Filip Kobencl (Cobenzl, * July 21, 1712 Ljubljana; † January 27, 1770 Brussels).

Ludvik count Kobencl (Cobenzl, Johann Ludwig Joseph, * 21 November 1753 Brussels; † 22 February 1809 Vienna).

Kasandra countess Kobencl, married Coronini (Cobenzl, * 1703; † 1788).

Robert Koch (* 1843; † 1910).

Emil Theodor Kocher (* 1841 Bern; † 1917).

Rudolf Albert von Koelliker (Kölliker, * 1817 Zürich; † 1905 Würzburg).

Franc Koestl (Köstel, * 1811 Cerklje in Upper Carniola; † 1882 Graz).

Otto Kofoed-Hansen (* 1921; † 1990).

Alfred Kohler (* 1943 Vienna), professor of modern history at Viennese University.

Thomas Köhler (Koehler) of AG Theoretische Physik, Fachbereich Physik, Univ.-GH Paderborn, Germany.

Rudolph Kohlrausch (* 1809 Göttingen; † 1858 Erlangen).

Ernst Arnold Kohlschütter (1883 Halle-1969 Bonn).

Wojciech Kojalowicz (Albertas Vijūkas-Kojelavičius, * 1605 Kaunas (Kowno); SJ 1627 Vilnius (Vilno); † 1677 Warsaw).

M.J. Kokalj, Lower Styrian technical correspondent of Maribor magazine *Zora*.

Jože Kokole (* 1937 Ljubljana), librarian.

Metoda Kokole, head of the Musicology institute at ZRC SAZU (SRC SASA).

Andrew of Kokorzyn (* 1379; † 1435).

František Koláček (* 1851 Slavkov u Brna (Austerlitz) in Moravia; † 1913 Prague), E. Mach's student.

Metod Kolar (* 1985), obtained his PhD under supervision of Miran Mozetič, Alenka Vesel and Karin Stana-Kleinschek in 2015.

Alan Charles Kolb (* 1928 Hoboken, NJ; † 2006 Rancho Santa Fe), head of a new Naval Research Laboratory in Washington DC, Plasma Physics Division in 1959. Created the new field of Pulsed

Power as science-technology concerned with very high power electrical pulses of the order of terawatts. Andreas Koller, manager of the Baron Žiga Zois' ironworks in Bohinjska Bistrica as father of Marian.

Ignatius Koller (Choler, * 1684 Linz; SJ 1699 Linz; † 1750 Vienna).

Marian Koller (baptized Wolfgang, * 31 October 1792 Bohinjska Bistrica (Feistritz) no. 87 in Upper Carniola; OSB 1816 Kremsmünster; † 19 September 1866 Vienna).

Franz Kollman (* 1839; † 1908).

Robert Kollman (* 1872; † 1932).

Anna Kołos (* 1987 Oleśnica in Poland).

Jan Amos Komenski (Comenius, Komenský, * 1592; † 1670).

Stanislav W. Kon (Станислав Викентьевич Кон, Konn, † 1876).

Heinrich Matthias Konen (* 1874 Cologne, † 1948 Bad Godesberg), professor at University Münster from 1905 to 1920, then he replaced Kayser at Bonn University.

Johann Samuel König (Koenig the younger, * 1712 Büdingen, Germany; † 1757 Zuilenstein near Amerongen, Netherlands), son of Samuel Heinrich König (* 1671 Gerzensee by Bern; † 1750 Bern).

Walter König (* 1859; † 1936).

Wenzel König (Venčeslav, * 1836; † 1901).

David Kurt Konstantinowsky (* 1892 Vienna; † London?).

Josip Kopinič (* 1911 Radoviči by Metlika; † 1997 Ljubljana).

Isak Kordić (Iso, * abt. 1856 Gornji Kosinj 25 km north of Gospić).

Arthur Korn (* 1870 Wroclaw; † 1945 Jersey City, New Jersey).

Henrik Viljem Korn (Wilhelm Heinrich, * 1754/1755 Maastricht in the Netherlands; † after 1821 Ljubljana?).

Branko Korošec (* 1927 Radovljica; † 1999 Ljubljana).

Jan Klaas Van der Korst (* August 25, 1931 Groningen, Nederland; † December 27, 2013 Loosdrecht, Nederland).

Simon Kos (Koss, * 1828 Kostrivnica near Rogaška Slatina in Lower Styria).

Sava Kosanović (* 1894; † 1956).

Thomas Koschat (* 1845 Viktring (Vetrinj) near Klagenfurt; † 1914).

Dragutin Kössler (Karl Koessler, * 1842) went to the royal Real School in Zagreb on 29 September 1873 while Juraj Bauer replaced him as professor of physics and mathematics at higher Grammar School Rijeka.

Josef Kössler (Joseph Koessler, Kessler, Kössler, * 1711 Bressanone (Brixen) in Tyrol; SJ 1728 Vienna; † 1771 Vienna).

Lado Kosta (* 11 February 1921 Strnišče by Ptuj refugee camp; † 1986).

Matevž Košir (* 1964 Kranj).

Martin Kothe († 1851 Köln).

Viktor Kotnik (* 1910 Zgornji Jakobski Dol; † 1991 Ljubljana).

Friedrich Theodor Kötteritzsch (* 1814 Bischofswerda at the western edge of Upper Lusatia in Saxony; † 1875) district physician in Pappendorf and 15 km eastern Freiberg in Saxony.

Ernst Theodor Kötteritzsch (* 1841 Pappendorf), the son of Friedrich Theodor, acquired PhD in Jena in 1868, published about electrostatics in 1868-1885, taught at Real Grammar School in Freiburg (Freiberger Realgymnasiums) in 1872-1882.

Janez Kovač (* 1965).

Zoran L. Kovačević (* 1935 Popinci by Pećinci (Попинци) in Srem, Vojvodina), a biochemist.

Lojze Kovačič (* 1951 Delnice in Gorski Kotar; SJ 1968 Dubrovnik/Ljubljana; † 2010 Borovnica by Ljubljana).

Alexandre Kouyré (Alexander Kouyre, Aleksander Vladimirovič Kojrakski, Александр Владимирович Койракский, * 1892 Taganrog in Russia; † 1964 Paris).

Venčeslav Koželj (* 1901; † 1968).

Johann Daniel Krafft (Kraft, Crafft, * 1624 Werheim; † 1697 Amsterdam).

Helge Stjernholm Kragh (* 1944 Copenhagen), a Danish historian of 19th century physics, chemistry, and astronomy. He earned his Ph.D. in physics in 1981 at the University of Roskilde in Denmark where he taught.

Boris Kraigher (Janez, * 1914 Sveta Trojica in Slovenske gorice; † 1967 Sremska Mitrovica).

Jurij Kraigher (Žore, Georg George, * April 3, 1891 Hrašče by Postojna, † September 17, 1984 Litchfield, Connecticut, United States).

Bernhard Kramer (* 1942 Naumburg (Hessen)) professor of theoretical physics, mostly in Dortmund, Braunschweig, Hamburg, and Bremen.

Jean-Baptiste Krantz (* 1817; † 1899 Paris).

Janez Jurij Krasnik (Joann Georg Krassnigg, Gonovuicensi, Gonobitz, * abt. 1672 Slovenske Konjice (Gonobitz, Gonovicensi) 17 km northeast of Celje in Lower Styria).

Tjaša Kraševac Glaser (* 1985).

Gregor Kraškovič (* 3 March 1767 Studenec at Bloke in today's Župan (Mayor's) house; † 1823 Pale by Dubrovnik).

Günther Kratky (* 1919 Faak am See near Villach (Beljak); † 1984 Graz).

Joseph Kraus (* 9 November 1678 Neumarkt in Styria along the upper Mura River; SJ 6 October 1696 Judenburg; † 16 November 1718 Osijek).

Emanuel Kregez (Kregetz, * 1829 Rakovník (Rakonitz, Rakonic) in the central Bohemia).

Karl Kreil (* 1798; † 1862 Vienna).

Johann Kremenezky (Kremenetzky, Josef Josefowitsch Leibensohn, * 1848 Odessa; † 1934 Vienna).

Franz Kreminger (* 27 October 1835 (or 1836) Pančevo; † 23 December 1915 Vienna) as former N. Tesla's teacher in Rakovac taught Ivan Cankar mathematics and geometric drawing (geometrische Zeichnen) in German language in 6th grade in 1892/1893, and mathematics in Cankar's last 7th grade in Ljubljana real school in 1893/1894.

Adolph knight Kriegs (later baron, * 1819 Vienna; † 1884 Vienna).

Friedrich Christian Kries (* 1768 Thorn; † 1849 Gotha).

Joseph Krist (* 1830 Stará Ves (Altendorf) in Moravia; † 1899 Graz).

William Justin Kroll (Guillaume, * 1889 Esch/Alzette, Luxemburg; † 1973 Brussels).

Herbert Krömer (Kroemer, * 1928 Weimar).

Leopold Kronecker (* 1823; † 1891).

Franz Krones Ritter von Marchland (* 1835 Uherský Ostroh (Ungarisch-Ostrau) in Bohemia; † 1902 Graz).

August Karl Krönig (* 1822; † 1879).

Djordj Krstić (* 1936 Novi Sad; † 2014 Kranj).

Johann Heinrich Krüsi (John Krusi, Cruz, * 1843 Heiden, Appenzell in Switzerland; † 1899).

Martin David Kruskal (* 1925 New York; † 2006 Princeton).

Janko Krušič, graduated at the Machine Engineering faculty in Ljubljana, worked on the problems of production of moulds for acrylic artificial teeth in 2000, three years later with Navinšek patented their procedure for surface hardening of hard-coated dental models.

Richard Küch (* 1860 Salmünster 40 km northeast of Hanau; † 1915 Hanau).

Josef Ritter von Kudler (* 1786 Graz; † 1853 Vienna).

Pavel Stepanovič Kudrjavcev (Павел Степанович Кудрявцев, Пáвел Степáнович Кудрjáвцев, * 1904 Bronnitsy (Брónницы) 50 km southeast of Moscow; † 1975 Tambov (Тамбов) in Central Russia) of Tambov State University now named after G. R. Derzhavin (TSU, Derzhavin Tambov State University, Тамбовский государственный университет имени Г. Р. Державина), author of first Soviet monograph about History of Physics heavily criticized by the philosopher, logician, chemist and psychologist Bonifaty Mikhailovich Kedrov.

Anton Kuhelj (* 11 November 1902 Opčine in Municipality of Trieste; † 31 July 1980 Ljubljana).

Thomas Kuhn (Samuel, * 1922; † 1996 Cambridge).

Werner Kuhn (* 1899 Maur am Greifensee; † 1963 Basel).

Hans Kuhn (* 1919 Berne; † 2012).

Klemen Kukec (Clemens Kukitz, * about 1500 Metlika; † 1541 Vienna).

Panteleimon Oleksandrovych Kulish (Panteleymon Kuliš, Пантелеймон Кулиш, * 1819; † 1897).

Kosta Kulišić (Kosto, Konstantin, Коста Кулишић, * abt. 1856; † after 1937 Sarajevo or Dunrovnik?)

Jurij Kunaver (* 1933).

Pavel Kunaver (* 1889 Ljubljana; † 1988 Ljubljana).

Johann Kunckel von Löwenstern (Kunkel, * 1630/1638 Wittenberg by Plön or nearby Hütten in Schleswig-Holstein); † 1703 Stockholm).

August Adolf Eduard Eberhard Kundt (* 1839; † 1894).

Maria Kunic married von Gerstmann and remarried von Love (Kunitz, Cunitz, Löwen, Lowen, * 1610 in Wołów in Polish Silesia; † 1664 Byczyna (Pitzen, Pitschen) in Poland).

August Kunzek Edler von Lichton (* 1795 Klimkovice (Königsberg) in the Moravian Silesia; † 1865).

Igor Vasiljevič Kurčatov (* 1903; † 1960).

Miroslav Kurelac (* 1926 Zagreb; † 2004 Zagreb), archivist and historian.

Primož Kuret (* 1935 Ljubljana).

Friedrich K. Kurylo, flourished 1959-1989, his collection of documents about Braun were arranged in the Huntington Library, Art Collections, and Botanical Gardens, Manuscripts Department, 1151 Oxford Road, San Marino, California in 2013.

Émile Küss (Kuss, * 1815 Strasbourg; † 1 March 1871 Bordeaux).

Valentin Kušar (* 1873 Rateče by Škofja Loka; † 1962)

Dušan Kuščer (* 1920; † 2012).

Ivan Kuščer (* 1918 Vienna; † 2000 Ljubljana).

Karl Kuzman (* 1941 Vitanje northeast of Celje halfway to Žreče).

Boris Grigorievich Kuznecov (Kouznetsov, Борис Григорьевич Кузнецов. * 1903 Dnipro (Дніпро, Днипрó, Днепр, Днепр, former Dnipropetrowsk, Дніпропетровськ, Днепропетровск, Dnepropetrowsk) in Ukraine; † 1984 Moscow).

Franc Kvaternik (* 1919 Osilnica; † 1981).

Konrad Kyeser (Conrad Keyser, * 1366; † after 1405).

L

Johannes from Laaz (* about 1380 Ledce (Laz, Laqtz) south of Brno).

Nicolas Louis de Lacaille (La Caille, * 1713 Rumigny; † 1762 Paris).

Abbé Paul-François Lacoste (sometimes mistakenly noted as Pierre, * 1755 Plaisance-du-Touch near Toulouse; † 1826 Clermont-Ferrand).

Sylvester François Lacroix (* 1765; † 1843).

Irena Lačen Benedičič (* Dravsko Polje in Slovenian Styria), director of Upper Sava River (Zgornjesavski) Museum in Jesenice.

Diogene Laerzio (* 180; † 240).

James M. Lafferty (* April 27, 1916 Battle Creek, Michigan; † 2006).

Giulio Cesare Lagalla (La Galla, * 1571 Padula by Salerno; † 1624 Rome).

Sven Torbjörn Lagerwall (* 1934).

Alessandro Laguzzi (* 1946; † 2018 Ovada in the Province of Alessandria in the northern Italian region Piedmont).

France Lah (* 30 May 1923 Prvenci 5 km east of Ptuj; † 25 September 1998 Ljubljana).

Ivo Lah (* 1896 Štrukljeva vas; † 1979 Ljubljana).

Gottfried-Xavier Laimbeckhoven (Nan Hoai-Jen Ngo-Te, * 1702 Vienna, SJ 27 January 1722 Vienna; † 22 May 1787 Tangjiaxiang by Songjiang east of Shanghai (T'ang-kia-hiang pi Su-choua) in China).

Gerard de Lairese (* 1641 Liège; † 1711 Amsterdam).

Henry Harris Lake, of the firm Haseltinc, Lake & Co., Patent Agents, 45, Southampton Buildings, in the County of Middlesex, Tesla's alternating current motors patent agent in UK in 1889-1898, active in 1879-1903.

Jérôme Lalande (* 1732; † 1807 Paris).

Joannis Baptist Lalangue (Ivan Krstitelj, Jean Baptiste, * 1743 Matton in then grand duchy of Luxemburg now Matton-et-Clémency in eastern France; † 20 May 1799 Varaždin).

Franc Josef count Lamberg (Jožef, adopted by the baron Langenmantl of Kostel manor in 1680, * 1673 Ortnek; † 1746).

Johann Heinrich Lambert (* 1727; † 1777).

Gabriel Lamé (* 1795; † 1870).

Johann Lamont (* 1805 Corriemulzie in Scotland; † 1879 Munich, Germany), the researcher of magnetism of earth, early observer of Neptune.

Anton Lampe (* 1868 Pest; † 1938).

Frančišek Lampe (* 1859 Zadlog between Idrija and Ajdovščina; † 1900 Ljubljana).

Bernard Lamy (* 16 June 1640 Le Mans; SJ; † 19 January 1715 Rouen).

Francesco de Lana Tertio (Terzi, * 1631; SJ; † 1687).

Lev Davidovich Landau (Davidovič, * 1908 Baku; † 1968 Moscow).

John Joseph Lander (* 1918).

Marsilio Landriani (* 1751 Milano; † 1827 Vienna).

Timothy Lane (* 1743; † 1807).

St. George William Lane Fox-Pitt (Lane-Fox, * 1856 Malta; † 1932 South Eaton Place in London).

Victor E. von Lang (* 1838 Vienna; † 1921 Vienna).

Bruno Albert Lange (* 1903 Berlin; † 1969 Berlin).

Fritz Lange (* 1899 Berlin; † 1987 Berlin).

Paul Langevin (* 1872; † 1946).

Irving Langmuir (* 1881; † 1957).

Heinrich von Langenstein (Heinrich Heinbuche, Heinrich von Hessen der Ältere (the senior), * 1325 Langenstein by Marburg in Hessen; † 1397 Vienna).

Sir Edwin Ray Lankester (* 1847 London; † 1929 London).

Joseph Lanzoni (* 1663; † 1738).

Pierre-Simon Laplace (* 1749; † 1827).

Ralph Eugene Lapp (* 1917 Buffalo; † 2004)
Manhattan project worker turned pacifist critics of the scientific elite.

Joseph Larmor (* 1857; † 1942).

Lawrence A. Larson of American Institute of Physics and American Vacuum Society.

Danilo D. Lasič (Dan, Laki, * 1952 Ljubljana; † 2000 California).

Dušan Lasič (* 1908 Gorizia (Gorica); † 1980 Vrsar).

Vida Jelka Tom married Lasič (* 1920 Zagorje ob Savi; † 1997 Ljubljana).

Antun Laska (Láska, * 1844/1847 Borohrádek (Heideburg) in the Bohemian Hradec Králové Region; † 1908 Osijek).

Václav Laska (Láska, * 1862 Prague; † 1943 Řevnice (Rzewnitz)).

Alonso Carrillo y Lasos (* 1582; † 1628 Córdoba).

Niels Ove Lassen (* 1914 Hammel; † 2008).

Jay T. Last (* 1929 Butler in Pennsylvania).

Max von Laue (* 1879; † 1960).

Robert Betts Laughlin (* 1950).

Bonaventura de Launoy printed in Offenbach by Frankfurt on Main in 1685-1724.

Luka Lavtar (* 1846; † 1915).

Antoine Laurent Lavoisier (* 1743; † 1794).

Harold B. Law (* 1911 Douds in southeast Iowa; † 1984 near Hopewell, New Jersey).

Ernest Orlando Lawrence (* 1901; † 1958).

John David Lawson (* 1923 Coverntry; † 2008).

Žarko Lazarević (* 1961).

Anton Lazari (Avguštin, * 1642 Ljubljana; OFM 1658; † 24 August 1705).

John Leard (Laird, * 1760; † 8 October 1843).

Alexandre Claude Martin Lebaillif (Le Bailiff (Lebailiff, Leballif, Baillif, * 1764 Saint-Fargeau; † 1831).

Petr Nikolaevich Lebedev (* 1866; † 1912).

Drago Lebez (* 1922 Borovnica; † 2015).

Félix Leblanc (* 1813 Firenze; † 1886 Paris).

Maurice Leblanc (Le Blanc, * 1857 Paris; † 1923 Paris).

Carl Lebmacher (* 1876 Kirschentheuer in Rosental; † 1943 Klagenfurt).

Giovanni Antonio Lecchi (* 1702; SJ; † 1776).

Ernst Lecher (* 1856; † 1926).

Georges Leclanché (* 1839; † 1882 Paris).

Leon Lederman (* 1920 New York; † 2018).

Jean Rodolph Lefèbvre (Faber, * about 1580; † 1650).

Louis Léger (* 1843; † 1923).

Adolph Lehmann (* 1828 Wroclaw (Breslau); † 1904 Vienna).

Gottfried Wilhelm Leibniz (* 1646; † 1716)

Johann Gottlob Leidenfrost (* 1715; † 1794).

Gustav Engelbert Leithäuser (* 1881 Hamburg; † 1969 Berlin).

Joseph-Adrien Lelarge de Lignac (* 1710 Poitiers; † 1762)

Benoit Lelong (Benoît), Université Paris-8, France, Faculty Member of CÉMTI (Centre d'études sur les médias, les technologies et l'internationalisation) department, published on sociology, history of science, and information communication in 1995-2020.

Louis Lemery (Lémery, * 1677; † 1743).

Nicolas Lemery (Lémery, * 1645 Rouen; † 1715 Paris).

Philipp Lenard (* 1862; † 1947).

Étienne Lenoir (* 1744; † 1832).

Robert Nicol Lennox (* 1861 Killin on Loch Tay in Perthshire in Scotland).

Augustin Gottfried Ludwig Lentin (* 1764 Dannenberg in Lower Saxony; † 1823 Sülbeck near Eimbeck).

Emil Lenz (* 1804 Tartu; † 1865 Rome).

Wilhelm Lenz (* 1888; † 1957).

Mihail Alexandrovich Leontovich (* 1903; † 1981).

Antoša Leskovec (* 1928 Radovljica; † 2007 Maribor).

Ivana Bizjak married Leskovec (* Cerkno) published in 1981-2021.

Sir John Leslie (* 1766; † 1832).

William Garrow Lettsom (* 1805; † 14 December 1887).

Leucippus from Miletus (Leukip, * 490 BC).

Jean Leurechon (* 1591 Bar-le-Duc; SJ; † 1670 Pont-à-Mousson).

Adrijan Levstik (* 1939 Brežice).

Vadim Leonidovič Levšin (W. L. Lewschin, Leonidovich Levshin, Вадим Леонидович Левшин, * 1896 Korcheva (Корчевá) abandoned and mostly submerged under the waters of the reservoir in 1936; † 1969 Moscow).

George Lewis (* abt. 1970 UK) University of Leicester's School of History and Centre for American Studies.

Gilbert Newton Lewis (* 1875; † 1946 Berkeley).

Ernst Friedric Leybold (* 7 November 1824 Rothenburg on Tauber; † 10 February 1907 Cologne).

Marie born Völker married Kothe remarried Leybold (* 1 November 1830 Köln; † 14 October 1890 Köln).

Franz von Leydig (* 1821 Rothenburg ob der Tauber; † 1908 Rothenburg).

Fortunio Liceti (* 1577 Rapallo; † 1657 Padua).

Georg Christoph Lichtenberg (* 1742 Ober-Ramstadt by Darmstadt; † 1799 Göttingen).

Ludwig Christian Lichtenberg (* 1737 Ober-Ramstadt by Darmstadt; † 1812 Gotha).

Maria Josepha countess Khuen von Belasi zu Auer und Lichtenberg (* 4 August 1721 Hall by Innsbruck; † 1 April 1784 Vienna).

Matjaž Ličer (* 1978), R. Podgornik's and Rado Riha's PhD student, physicist-philosopher employed at the Marine Biology Station of the National Institute of Biology dealing with physical oceanography & numerical modeling of pollutant spreading in marine environments.

Ignaz Isak Leopold Lieben (* 28 February 1805 Prague; † 12 March 1862 Vienna).

Robert von Lieben (* 1878 Vienna; † 1913 Vienna), a wealthy Jewish Nernst's student, a grandson of Ignaz Isak Leopold Lieben.

Antoine Liebes (* 1752; † 1832).

Justus Liebig (* 1803; † 1873).

Raphael Eduard Liesegang (* 1869; † 1947).

Edwin Niblock Lightfoot Jr. (* 1925 Milwaukee, Wisconsin, United States; † 2017 Madison, Wisconsin, United States) was an American chemical engineer and Hilldale Professor Emeritus in the Department of Chemical and Biological Engineering at the University of Wisconsin-Madison.

Julius Edgar Lilienfeld (* 1882 Lvov; † 1963 Charlotte Amalie at US Virgin Islands).

Karl Paul Gottfried von Linde (* 1842; † 1934).

Bernhard August von Lindenau (* 1780 Altenburg; † 1854 Altenburg).

Otto Theodor Lindenthal (* 1872; † 1947 Vienna) physician in Vienna, director of Viennese Mariannengasse 20 Sanatorium of Anton Löw (Loew, * 1847; † 1907 Vienna).

Wang Ling (王鈴, 王铃, 1917/1918 Nantong (南通, Nántōng, Nan-t'ung, Nantung, Tongzhou, Tungchow); † 1994 Nantong).

Heinrich Friedrich Link (* 1767 Hildesheim in Lower Saxony; † 1851 Berlin).

Karl Linnaeus (* 1707; † 1778).

Franciscus Linus (Hall, * 1595; † 1675).

Alojzija Kajetana Kahr married Lipič (Lippich, * 1805 Ilz).

Ferdinand Lippich (* 1838 Padua; † 1913).

Fran Viljem Lipič (Franz Wilhelm Lippich, Fr. Guilielmus Lippich, * June 13, 1799 Spišská Nová Ves (Igló) west of Košice in Slovakia; † December 12, 1845 Vienna).

Friedrik Lipič (Lippich, * 1832 Ljubljana).

Jožef Lipič (Lippich, * February 5, 1761 Ljubljana).

Tereza Lipič married Koestl (* 1800).

Wilhelmine Lipič married Czermak (Lippich, * 1831 Ljubljana; † 1885 Prague).

Emile Armet de Lisle (Émile, * 1853; † 1928), owner of manufacture *Sels de radium* at the eastern suburbs of Paris Nogent-sur-Marne.

Jules Antoine Lissajous (* 1822; † 1880).

Johann Benedict Listing (* 1808 Frankfurt; † 1882 Göttingen).

Liu Yan (Liu An, * 177/179 B.C. ; † 122 B.C.).

Milton Stanley Livingston (* 1905; † 1986).

voluntarist Scotist Thomà Llamazares (Thomas, * Valladolid (Vallisoletano) in Spain's northwest interior; OFMobs; † abt. 1690 Firenze?), published in 1670-1688).

Wenzel Franc Lobkowitz (Wencel Evzebius, * 20 January 1609 Prague; † 22 April 1677 Radvnitz (Roudnitz, Rudnice) near Laba in the district of Letimeritz (Litomerice)).

Alipius Locherer (OFMobs Stein at western part of Krems in Lower Austria), published 1740-1732.

Joseph Norman Lockyer (* 1836; † 1920).

Robert Locqueneux (* 1937).

Oliver Joseph Lodge (* 1851; † 1940).

Alexander Nikolaevich Lodigin (Lodyguine, Александр Николаевич Лодыгин, * 1847 Стеньшино, Липецкий уезд, Тамбовская губерния Russia; † 1923 New York).

Siegmund Loewe (* 1885; † 1962).

Augustin Löffler (Jaromir, Ante, Czech Bohemian, published 1872-1879, * 1832 Jindřichův Hradec in the South Bohemia; † 1915 Prague?).

Johann Siegfried Löffler since 1822 the first forest director (Wald Director) of the Karlovac Forest Management.

Augustin's son Ladislav Löffler (* 1860 (Velika) Kikinda in Serbian Banat).

Philipp Lohmeier (* 1648 Magdeburg; † 1680 Lüneburg).

Eugen von Lommel (* 1837; † 1899).

Luise Friederike Caroline Hegel married von Lommel (* 1853; † 1924).

Mikhail Vasilyevich Lomonosov (* 1711; † 1765).

Josip Lončar (* 1891; † 1971).

Conrad Lee Longmire (* 1921; † 2010 Santa Barbara).

Alfred Lee Loomis (* 1887 New York; † 1975 East Hampton New York).

Hendrik Antoon Lorentz (* 1853; † 1928).

Hans Lorenz (* 1865 Wilsdruff west of Dresden in Saxony; † 1940 Sistrans by Innsbruck in Austrian Tirol) in 1917 rector of Technische Hochschule Danzig as full professor of technical mechanics (technische Mechanik).

Stanislaw Loria (* 1883 Warsaw; † 1958 London).

Karl of Lorraine (* 12 December 1712; † 1780).

Luis de Losada Prada (Lossada, * 1681 Quiroga, Lugo in Spain; SJ; † 1748 Salamanca).

Josef Loschmidt (* 15 March 1821; † 8 July 1895).

Josef Karl Loschmidt (* 18 February 1888; † 23 June 1898 Vienna).

Jurij Ahac Count of Losenstein (Georg Achaz, * 1597; † 1653).

Marie Katarina Countess Losenstein, married princess Auersperg (* 1635 Carinthia; † 1691 Ljubljana?).

Oleg Vladimirovič Losev (Олѐг Владѐмирович Лóсев, Lossev, Lossew, * 1903 Tver; † 1942 Leningrad).

Paulin-Laurent-Charles-Évaléry Louyet (* 1818 Mons; † 1850 Brussels).

Gloria Becker married Lubkin (* 1933 Philadelphia; † 2020 Raleigh, North Carolina), a Jewish editor for the magazine Physics Today, cofounder of the Theoretical Physics Institute at the University of Minnesota.

Jean André De Luc (* 1727; † 1817).

Tomaso Luciani (* 1818 Albona; † 1894 Venezia).

Christian Friedrich Ludolf (Ludolff, * 1707; † 1763), member of Berliner Academy of Science from 1738.

Carl Friedrich Wilhelm Ludwig (Karl, * 1816 Witzenhausen 20 km south of Gottingen; † 1895 Leipzig).

Christian Friedrich Ludwig (* 1757 Leipzig; † 1823 Leipzig).

Karl Lueger (* 1844; † 1910).

John de Lugo (Juan de Lugo y de Quiroga, Xoan de Lugo, * 1583 Madrid; SJ; † 1660 Rome).

Francesco Luini (Luino, * 1740; SJ; † 1792).

Johannes Lulofs (Jan Lulofs, Johan, * 1711 Zutphen; † 1768 Leiden).

Otto Lummer (* 1860; † 1925).

Salvador Luria (* 1912; † 1991).

Joaquin Mazdak Luttinger (Quin, * 1923 New York; † 1997).

Emperor Charles IV of Luxemburg (Karl, * 1316; † 1378).

Sigismund I of Luxemburg (* 1368; Hungarian king 1387, Emperor 1410/1417, Bohemian king 1419-1421, 1436-1437; † 1437).

Vaclav of Luxemburg (Wenceslaus IV, * 1361; † 1419).

Vitalii Nikolaevich Lystsov (Виталий Николаевич Лысцов, Vitaly Lyscov) leading researcher at the National Research Centre "Kurchatov Institute" in Moscow (Национальный исследовательский центр (previously Российский научный центр Курчатовский институт).

Lysenko (Трофим Дени́сович Лысе́нко, Трохим Денисович Лисенко, * 1898; † 1976).

M

Ernst Mach (* 1838; † 1916).

Johan Nepomuk Mach (* 1805; † 1879).

Marie Mach (* 1844; † 1929).

Robert Macquériau de Valenciennes (Macquériau), early 16th century French Catholic townsman from Valenciennes in French Burgundy on Dutch border.

Theodore Eugene Madey (Ted, * 1937 Wilmington, Delaware; † 2008 Somerset in New Jersey).

Madhava (* 1340 Sangamagrama; † 1425).

Urban Madko (Matko, Madcho, * 1704 Tolmin; † 1741 Venezia).

Michael Maestlin (* 1550; † 1631 Tubingen).

Francis Janez Neri de Maffei (* 23 November 1738 Vipava; † 8 January 1826 Duomo in Gorizia).

Marquess Francesco Scipione de Maffei (* 1 July 1675 Verona; † 11 February 1755 Verona)

Joseph Jakob Liberatus Maffei von Glattfort (de Glattfort, * August 15, 1742 Gorizia, † 1807 Vienna).

Lorenzo count Magalotti (* 1637; † 1712).

Božidar Magajna (* 11 December 1912 Ljubljana; † 2012).

Andreas Maginot (* 1877; † 1932).

Constantine Magni (Costantino, * 1527; † 1606).

Francisco Stephano de Magni count Strážnice (Strassnitz in Moravia, † 1671).

František z Magni (František Magnis ze Strážnice, * 1598; † 1652).

Valeriano Magni (Maximilian Magnani, Valerij Magnus, * 11 October 1586 Milan, OFM Cap 25 March 1602 Prague; † 29 July 1661 Salzburg).

Pierre-André d'Héguerty count Magnières (* 1700; † 1763).

Bishop Albertus Magnus (count Bollstädt, * 1193 Lauingen in Bavaria; † 15 November 1280 Köln).

Heinrich Gustav Magnus (* 1802; † 1870).

Bishop Olaus Magnus (Olof Månsson, * 1490 Östergötland; † 1557 Rome).

Gustav Mahler (* 1860 Kaliště in Czechia near Moravian border; † 1911 Vienna).

Sebastian De Maillard (* 1746; † 1822).

Jean Jacques D'Ortous de Mairan (Dortoux, * 1678; † 1771).

Matija Majar (* 1809 Wittenig (Vitenče) in Zilja (Ziljska Dolina, Gail valley); † 1892 Prague).

Simone Majolo (Simon Mayolus, Majoli, * abt. 1520 Asti in Piemonte; † after 1597 Vulturara or Montecorvino), Bishop of Vulturara and 50 km southern Montecorvino in southeast Italy east of Napoli from 1572 until his death.

Ettore Majorana (* 1906; † 1936).

Paul Mako von Kerek-Gede (Pál Makó, Paulus Makus Kerck, * 1723 Jászapáti in Central Hungary; † 1793 Buda).

Radojko Maksić (* 28 October 1933 Popova by Jastrepac in Serbia).

Ernest-François Mallard (* 1833; † 1894 Paris).

Edward Mallinckrodt (* 1878 Saint Louis; † 1967).

Arthur Mally (* 1843; † 1919).

Étienne Louis Malus (* 1775; † 1812).

Richard Maly (1839; † 1891).

Kenneth E. Manchester (Ken, * 1925 Winona, Minnesota; † 2014).

Valentin Mandelc (* 1837; † 1872).

Joseph Mangold (* 1716 Rehling in Swabia; SJ 1733; † 1787 Augsburg).

Maria Franciska von Mansfeld, married Countess Losenstein († 1654).

Angelo Maria Meraviglia Mantegazza († 1766).

Jacob Mantino ben Samuel (Mantinus, Mantini, * 1490 Tortosa, Spain; † 1549 Damascus, Syria) Jewish scholar turned Italian physician.

Carlo Giuseppe Matteo Marangoni (* 1840 Pavia; † 1925 Firenze).

Wilhelm Marášek (Vilim, Viljem Marašek, * 1847 Prague; † 1894 Travnik in Bosnia).

Jean-Paul Marat (* 1743 Boudry in western Switzerland; † 1793 Paris).

François-Séverin Desgravières-Marceau (* 1769; † 21 September 1796 Altenkirchen).

Marquess Guglielmo Marconi (* 1874; † 1937).

Siegfried Samuel Marcus (* 1831 Malchin in northern Germany; † 1898 Vienna).

Abbé Jean François Marcy (Marco, baptized Jean Bosquet, * 1711 Verdun; † 1791 Löwen (Leuven, Louvain)).

Sibe Mardešić (* 1927 Bergedorf as the largest of the seven boroughs of Hamburg; † 2016 Zagreb).

Baltzar Emil Leo de Maré junior (DeMare, * 1904 Philadelphia Germantown, Pa.; † Germantown, Pa.), whose father with the same name graduated from the School of Mines in Falun in Sweden in 1886 and sailed to the US in 1887 to become a Senior mechanical Engineer at Middwall Steel Works in Philadelphia.

Bernhard Marek (Mareck), engineer in Graz, published in 1861-1867. Relative of Alois Titus Marek (* 1819 Graz; † 1851 New Braunfels (Neu Braunfels, Neubraunfeld) in central Texas), lawyer in Graz and Sevnica (Lichtenwald), revolutionary delegate to Frankfurt Parliament in 1848.

Andreas Sigismund Marggraf (Margraff, * 1709; † 1782).

Lev Margulis of Weizmann Institute of Science, praised by Israeli Margulis Memorial Prize in the field of Microscopy, applied to Materials Science.

Maria Prophetissima, Maria Prophetissa, Mary Prophetissa, Miriam the Prophetess, the Jewess, flourished in 1st/3rd century A.D. in Alexandria in Egypt.

Aleksandar Marinčić (Александар Маринчић, * 1933 Sinj in Croatia; † 2011 Beograd).

Vincent Marjašič (Vincenzio Mariaschitz, OFM; † 13 January 1770 Kamnik).

Pietro di Maricourt (Petrus Peregrinus, * around 1220).

Velibor Marinković (* 1929; † 12 October 2000 Ljubljana).

Giovanni Giacomo Marinoni (* 1676; † * 1755 Vienna).

Edmé Mariotte (* 1620; † 1684).

Hieronim Markilič (* 1712; OFMobs; † 24 May 1790 Ljubljana).

Mihael Markič (M. Posavski, * 1864 Kranj; † 1839 Ljubljana).

Ivan Marković (* 1961 Koper).

Raja Marković-Adamov (Pavle, Паја Адамов Марковић, * 1855 Novi Karlovci in Srem; † 1907).

Željko Marković (* 1889 Slavonska Požega; † 1974 Opatija).

Duke of Dubrovnik Marshal Auguste-Frédéric-Louis Viesse de Marmont (* 1774; † 1852).

Ernest Marsden (* 1889; † 1970).

Roger Marston (* around 1235; † about 1303).

Benjamin Martin (* 1704 Worplesdon; † 1782 London).

Craig Martin (* 1972).

Émile Martin (* 1794 Soissons; † 1871 Fourchambault).

Louis Aimé-Martin (Aimé Martin, M.L., * 1782 Lyon; † 1847 Paris).

Pierre-Émile Martin (* 1824 Bourges; † 1915 Fourchambault).

Thomas Commerford Martin (* 1856 London; † 1924).

Martino Martini (* 1614 Trento; SJ; † 1661 Hangchou China).

Bernard Ignátz count Martinitz Bořita (Borsita, * 1603; † 1685 Prague) the highest burgrave of Prague, royal viceroy, bibliophile, founder of the Theatine monastery in Prague.

Jean-Claude Martzloff (* 1943; † 2018 Paris).

Martin van Marum (* 1750; † 1837).

Karl Marx (* 1818; † 1883).

Phoebe Sarah Marx married Ayrton (Marks, Hertha, * 1854 Portsea; † 1923 Bexhill-on-Sea).

Giovanni Battista Marzari (* 1755; † 1827).

Galeotto Marzio (* 1427; † 1497).

Rita Mascarenhas (* 1952 Puttur, Karnataka, India; † 2005 Delmar, Albany County, New York, USA) worked at Department of Physics, Utkal University, 751004, Bhubaneswar, India. Later joined the State University of New York at Albany (SUNY Albany, UAlbany). Collaborated on 3-D reconstructions of electron microscope images at Wadsworth Center in Albany, New York, the research-intensive public health laboratory of the New York State Department of Health. Married to her Albany collaborator physicist David Barnard.

Francesco Massardi (* 1880 Brescia; † 1957 Sulzano).

Blaž Matek (* 5 February 1855 Gornji Grad ob Dreti (Upper castle by Dreta River); † 29 January 1910 Maribor).

Georges Mathé (* 9 July 1922; † 15 October 2010).

Franz Eugen Mathon (Franjo, František, * 10 February 1828 Slavětín (Slawietin) in Olomouc District; † 1893 Vienna) studied law and philosophy at Charles-Ferdinand University in Prague until his doctorate in

philosophy in 1854. In 1855 he passed the teacher's exams in mathematics and physics for grammar schools, and a year later he also obtained an apprenticeship for teaching the Czech language. He first replaced the botanist Giuseppe Accurti as a substitute teaching mathematics, physics, natural history and propaedeutic at the grammar school in Rijeka in October 1854, but the Rijeka director and Johann knight Kleeman did not promote Mathon to the rank of full professor because of his suspicious Pan-Slavic ideas. Mathon then taught in Brno, and at the real school in Olomouc. In 1856 he served as a supplied teacher at German State High School in Brno (Deutschen Staats-ober-Gymnasiums in Brünn (Altbrünn)) together with Pisko. Mathon taught physics (1857/58), Czech and French Languages as the director of the newly established Communal Lower (later Higher) Real school in 4th Bezirk of Brno (Staré Brno) from 28 September 1857 to 1885. He became a member of Naturalist Society in Brno (Naturforschender Verein in Brünn) after the board member Ignaz Weiner's proposal on June 1, 1862. The retired director Mathon served as a member of the Imperial Council (the national parliament of the Předlitavsko region) for the Curia of rural municipalities in Moravia, Brno, Vyškov district, etc. from March 23, 1886 until 1891. At the Imperial Council, he joined the Czech Club, which since the late 1870s has united Old Czechs, Young Czechs, the Czech Conservative nobility, and Moravian national deputies (Trdina, 1903, 162-163).

Carlo Matteucci (* 1811 Forli; † 1868 Livorno).

Camille Arthème Matignon (* 1867 Saint-Maurice-aux-Riches-Hommes (Yonne); † 1934 Paris)

Adolf Matthias (* 1882; † 1961).

Donald Moss Mattox (Don, * 1933 Richmond, Kentucky) received B.S. in physics at Eastern Kentucky State University in 1953, and M.S. in solid state physics at University of Kentucky in 1961. He married Vivienne Harwood Mattox as his co-founder of Management Plus, Inc. MPI incorporated in Albuquerque NM in 1985. Don was elected president of the American Vacuum Society in 1985. He later became the technical director of the Society of Vacuum Coaters. He worked at Sandia National Laboratories until retirement in 1989.

Pierre Louis Moreau de Maupertuis (* 17 July 1698 St. Malo; † 27 July 1759 Basel).

Silvestro Mauro (Sylvester Maurus, * 1618/19 Spoleto in Umbria; SJ; † 1687 Roma).

Francesco Maurolico (* 1494; † 1575).

John Mawson (* 1816 Penrith; † 1867 Newcastle).

E. May (probably Edmund) of Loom & machine factory formerly May & Kühling in Chemnitz (Webstuhl- & Maschinenfabrik vormals May & Kühling). Possibly related to German business journalist and co-founder of the consumer, construction, and savings association "Production" Raphael Ernst May. E. May owned Manufacture and sale of textile machines, especially looms and preparation machines as well as machine tools, founded on August 24, 1872 under the takeover of the enterprise of Anton Zschille, which had existed since 1852 as the company Grossenhainer Loom and Machine Factory (formerly Anton Zschille) in Grossenhain in Saxony. Since 1890 the company name was Grossenhainer weaving mill and machine factory (formerly Anton Zschille) as branch of the loom and machine factory (formerly textile machine factory May & Kühling) in Chemnitz after they fused in 1889. In 1900 it was renamed to Grossenhainer loom and machine factory AG until it joined Unionmatex Association of German Textile Machinery Manufacturers GmbH, Berlin in 1943. May and Kühling store had been in existence in Chemnitz for many years before fusing to build lighter looms for clothing fabrics and the like as textile machine factory. Moritz Kühling from Chemnitz and Edmund May from Berlin were the readers of the magazine *Schacht und Hütte* edited by Karl May for Heinrich Gotthold Münchmeyer in 1875/76. They participated in solving puzzles while Edmund also sent contributions to the magazine for all sorts of things.

Karl May (* 1842; † 1912).

Raphael Ernst May (* February 21, 1858 London; † July 7, 1933 Hamburg).

Alfred Marshall Mayer (* 1836; † 1896).

Daniel Mayer (* 1930) professor of Theoretical and Experimental Electrical Engineering at the Faculty of Electrical Engineering of the University of West Bohemia in Pilsen.

James Walter Mayer (* 1930 Chicago; † 2013 Kailua-Kona, Hawaii).

Julius Robert Mayer (* 1814; † 1878).

Theodor WH Mayer (* 1825).

John Mayow (* 1640; † 1679).

Caroline Magdalena Barbara Mayr married Loschmidt (* 1846 Bozen; † 13 February 1930).

Gustav Ludwig Mayr (* 12 October 1830 Vienna; † 14 July 1908 Vienna).

Janez Krstnik Mayr (* 1686 Sillian in the district of Lienz in Tyrol; SJ; † 1748 Ljubljana).

Janez Krstnik Mayr (Johann Baptist Mayer, * 9 February 1693 Vienna; SJ 9 October 1708 Vienna; † 25 January 1760 Krems).

Janez Krstnik Mayr (* 20 February 1634 Frauen-Chiemsee in Bavaria; † 1708 Salzburg).

Karoline Mayr (* 23 February 1885; † 13 December 1950).

Hiram S. Maxim (* 1840; † 1914).

James Clerk Maxwell (* 1831; † 1879).

cardinal Giulio Mazarin (Mazarini, * 1602; † 1661).

Cardinal Michele Mazzarino (Mazzarini, Michel Mazarin, * 1605 Pescina; † 1648 Rome).

Count Giammaria Mazzucchelli (* 1707; † 1765).

Russell McCormmach (* 1933 USA).

James MacCullagh (* 24 October 1809 Landahaussy; † 24 October 1847 Dublin).

Sir William Christopher Macdonald (* 1831; † 1917 Montreal).

Ives W. McGaffey inventor based in Chicago, Illinois in 1860-1889, joined a local firm of J. H. Brown.

Étienne-Vincent Machuel (* 1719 Rouen; † 1781 Rouen), printer.

James Scott Maclaurin (* 1864 Unst the northernmost of the inhabited Shetland islands in Scotland; † 1939 Wellington).

Herbert G. McLeod (* 1841; † 1923).

Frederick A. McNally (Fred) worked for Research and Development, Jarrell-Ash Company, 165 Newbury Street, Boston, Massachusetts in 1950-1960, founded by J. O. Jarrell († 1943) in 1933 and joined by his assistant Ash. Fred became the Chairman of the Committee on Education od AVS.

Donella H. Meadows (Dana, * 1941 Elgin, Illinois; † 2001 Hanover, New Hampshire).

Dennis, L. Meadows (* 1942 Montana).

Cornelius Franciscus Nelisa uit Mechelen (* 1736; † 1798).

András Mechwart (* 6 December 1834 Schweinfurt; † 14 June 1907 Budapest).

Richard of Mediavilla (* around 1249; † about 1307).

Vladimir Medica (* 1950 Pula), professor at Faculty of Engineering of University of Rijeka in Croatia (RITEH).

Cosimo II de'Medici (* 1590; † 1621).

Cardinal Giovanni Carlo de'Medici (* 1611; † 1663).

Prince Leopoldo de'Medici (* 1617; † 1675).

Friedrich Casimir Medicus (* 1736; † 1809).

Mojsije Medić (Mojo, * 1855 Ličko Dobroselo east of Gospić; † 1939 Zemun).

Hieronimus Megiser (Hijeronim, * 1554/1555 Stuttgart; † November 1619 Linz).

Heinrich Meidinger (*1831 Frankfurt am Main; † 1905 Karlsruhe) constricted his Voltaic cell with constant voltage as bettered John Frederick Daniell's cell in 1859.

Alexander Meissner (Meißner, * 1883 Vienna; † 1958 Berlin).

Paul Traugott Meißner (* 1778 Mediasch in Romania; † 1864 Vienna).

Lise Meitner (Elise, Lisa, * 1878 Vienna; † 1968 Cambridge).

Barthol Mastrio de Meldula (* 1602 Meldola (Meldola) by Forlì in Emilia-Romagna; † 1673 Meldola).

Aleksander Mell (* 1850 Prague; † 1931 Vienna).

Louis Henry Friderik Melsens (* 1814 Leuven; † 1886).

Luigi Federico Menabrea (* 4 September 1809; † 24 May 1896).

Menachem Genut, Tel Aviv University (TAU) Department of Chemistry.

Dmitry Ivanovich Mendeleev (Mendeleev, * 1834; † 1907).

Kurt Alfred Georg Mendelssohn (* 1906, Berlin; † 1980, Oxford, United Kingdom), a great-great-grandnephew of philosopher Moses Mendelssohn.

Thomas Corwin Mendenhall (* 1841; † 1924).

Francisco de Mendoca (Mendoça, Medoza, Mendonça, * 1573 Lisbon (Olisiponensis); SJ; † 1626).

Guglielmo Menis (Vilim, William, Willelmo, * 1790 Artegna north of Udine, † 1850 Trieste).

Ivan Nepomuk Menner (Joann G. Maenner, Johann Gregor? Manner, Männer, * abt. 1767 Western Austria; † aft. 1846 Zagreb?).

Louis-Sébastien Mercier (* 1740; † 1814).

Hubert de Méricourt (Li Tsuen-Hien Si-Tschen, * 1 November 1729 France; SJ 8 January 1754 France; † 20 August 1774 Beijing).

Harrison J. Merrill (* 1913 Preston, Idaho; † 2008 Reston, VA).

Joannes Merinero (Juan López, * 1583 Madrid; OFMobs 1600 Madrid; † 1663 as a bishop in Valladolid in northwest Spain).

Marin Mersenne (* 1588; † 1648).

Ivan Krstnik Mesar (Messari, Johann Baptist, * 1673 Mesari near Branik; † 1723 Hanoi, Vietnam).

Baron Georg Ignaz von Metzburg (Mezburg, * 24 June 1735 Graz, SJ 17 October 1751 Vienna; † 3 March 1798 Vienna)

Joseph Sebastien Meyer (* 1763; † 1834).

Kirstine Bjerrum married Meyer (* 12 October 1861 Skærbæk; † 28 September 1941 Hellerup).

Oskar Emil Meyer (* 1834; † 1909).

Robert Bruce Meyer (* 1943 Saint Louis).

Stefan Meyer (* 1872 Vienna; † 1949 Bad Ischl) the head of The Institute for Radium Research (Institut für Radiumforschung) of the (Imperial) Academy of Sciences founded in Vienna in 1910 as the first institute in the world to research radioactivity until his retirement in 1947 except for his expulsion because of his Jewish origin in 1938-1945.

Wilhelm Heinrich Theodor Meyer (Ludwig Christian Karl Mayer, * February 8, 1820/1825 Michelbach part of Marburg in Hesse (Nassau)). Might be related to his much northern namesake Wilhelm Carl Heinrich Theodor Meyer (* 1829

Eldena in Mecklenburg, Germany; † 1908 Grabow in Mecklenburg, Germany).
John Michell (* 1724; † 1793).

Albert Abraham Michelson (* 1852 Strzelno; † 1931 Pasadena).

Fritz Michelssen, collaborator of Schröter for Telefunken in 1930s until he joined Neufeldt & Kuhnke Gesellschaft at Berlin-Steglitz in 1938, retired to Berlin-Friedenau Cranachstraße 20 in 1950/1951.

William Edgar Knowles Middleton (* 1902 Canada; † 1988 Canada).

Benjamin Franklin J. Miessner (* 1890 Huntingburg, Indiana; † 1976 Miami, Florida).

Miodrag V. Mihailović (* 1922 Čačak; † 2014 Ljubljana).

Dénes von Mihály (* 1894; † 1953).

Jurij Miklavčič (Miklautschitsch, * 1756 Zali log in Upper Carniola; † 1829 Ljubljana).

Marko Mikšić (* 1847) member of the unity of Czech mathematicians, professor of geometry and geometric designs as a custodian of geometrical cabinet, leader of meteorological observations in Rakovac in 1882/83.

Mina born Miller married Edison (* 1865 Akron in Ohio; † 1947).

William Hallows Miller (* 1801 Wales; † 1880 Cambridge).

Robert Andrews Millikan (* 1868; † 1953).

Benedetto Milocco (fl. 1747-1785 in Venezia).

John Milton (* 1608; † 1674).

Franz Minck (Mink, * 23 August 1868 Hamburg) obtained his PhD in Munich in 1891 where he researched in following years.

Honoré Gabriel Riqueti count de Mirabeau (* 1749; † 1791).

Victor de Riquetti marquis de Mirabeau (* 1715; † 1789).

Slobodan Mircevski (Mirčevski, Слободан Мирчевски, * 1950 Skorje (Скопје) Macedonia), Faculty of Electrical Engineering and Information Technologies, Ss. Cyril and Methodius University, Skorje, Macedonia (Електротехничкиот факултет, Универзитет Св. Кирил и Методиј-Скопје).

Jovan Mitrović (* 1943 Strijezevica, Maglaj, northern Bosnia and Herzegovina), retired professor at the Universities Paderborn and Stuttgart, now professor at Serbian Republic Trebinje University of East Sarajevo.

Clara Louise Mitscherlich (* 1827).

Eilhard Mitscherlich (* 1794; † 1863).

Heinrich Mitteis (* 1 April 1822 Prague; † 15 May 1878 Vienna).

Milorad Mladjenović (Mladenović, Mladženović, * 1920 Sarajevo; † 2005) head of spectroscopy department in Vinča by Beograd.

Emilija Mlakar, married Branz, the mathematician.

Gojmir Mlakar, surveyor and mountain climber raised in Kočevje.

Jasna Mlakar, department of history at Ljubljana Philosophical Faculty.

Jože Mlinarič (* 1935 Maribor).

Thomas Młodzianowski (Tomasz Młodzianowski, * 1622 Ciechanów (Zichenau) in north-central Poland; SJ 1637; † 1686 Wolbrom (Wolfram) by Krakow in Southern Poland).

Catholic Archbishop of Nicosia Philip Mocenici (* 1536; † 1571).

Franc knight Močnik (* 1814 Cerklje; † 1892 Graz).

Gregor Moder (* 1979 Ljubljana).

Peter Anton von Modesti (* 29 July 1750 Ljubljana)
the son of dr. Valentin von Modesti († 1800).

Stjepan Mohorovičić (* 1890; † 1980).

Carl Friedrich Christian Mohs (* 1773; † 1839).

François-Napoléon-Marie Moigno (François
Napoleon Marie, * April 15, 1804 Guéméné
(Morbihan) in Brittany; SJ 2 September 1822-
October 1843; † 14 July 1884 Saint-Denis (Seine)).

Henri Moissan (* 1852; † 1907).

Johann August Georg Edmund Mojsisovics von
Mojsvar (Moissisovics, Ödön, Mojsisović, * 1839
Vienna; † 1907 Mallnitz by Spittal in Carinthia).

Frederick de Moleyns (William Mullins, * 1804
Killiney in county Kerry in Ireland; † 1854 Newgate
prison in London).

Joseph Privat de Molières (* 1734; † 1739).

Pedro Juanete de Molina (* 1698 Onil in the Spanish
province of Alicante south of Valencia; † 1775 Vila-
Real in Northern Portugal).

Anton Moljk (* 1916; † 1998).

Joseph Mollet (1756; † 1829).

Anton Mollinary (Molinari baron Monte Pastello, *
1820 Titel in Bačka; † 1904 Soave by Como in
Lombardy).

Nicolò Monardes (Nicolau Monardis, * 1493
Seville; † 1588 Seville).

Edward Henry Cradock Monckton (* 1812; † 1878
Fineshade Abbey, Northants (Northamptonshire)
buried 6 miles west in family vault at Seaton,
Rutland) collected Indic data about science,
alchemy, chemistry, and agriculture as an official for
the East India Company in Bengal before retiring to
Fineshade Abbey, Northants (Northamptonshire).

Carlo Mondini (* 1729 Bologna; † 1803).

Edmond Marey Monge (Louis Eduard Marey-
Monge, * 1807 Nuits-Saint-Georges in Eastern
France; † 1868 Paris).

Gaspard Monge (* 1746; † 1818).

Jean-André Mongez (* 1750 Lyon; † 1788 Vanikoro
of Solomon pacific Islands during the expedition of
Jean François de Galaup count Lapérouse (La
Pérouse)), priest and mineralogist.

Ovidio Montalbani (* 1601 Bologna; † 1671
Bologna).

Geminiano Montanari (* 1633 Modena; † 1687
Padua).

Ferdinand de Montagnana (Montegnana, * 1599
Ljubljana or Celje; † 28 May 1674 Vienna).

Polidor de Montagnana (Montegnana, * Italy; †
1604 Novo mesto).

Severus Montagnana (* about 1579; † before 1602).

Guidobaldo marquis del Monte (Guido Ubaldo
Montis, Guidobaldi, Guido Baldi, * 1545 Pesaro; †
1607 Montebardino).

Giovanni Battista Monteggia (Giambattista, * 1762
Laverne; † 1815 Milano).

Joseph Michel de Montgolfier (* 26 August 1740
Videlon-les-Annonay; † 26 June 1810 Belaruc-les-
Bains).

Jacques Étienne de Montgolfier (* 7 January 1745
Videlon-les-Annonay; † 2 August 1799 Serrières).

Scott L. Montgomery (* 1951 Ithaca New York).

Pierre Petit de Montluçon (* 1598; † 1671).

Henry Louis Habert de Montmor (* about 1600
Paris; † 1679 Paris).

Livius Rabeanus da Montursio of Vicenza (Livio
Rabesano, * 1605 Vicenza; † 1664).

Daniel McFarlan Moore (* 1869 Pennsylvania; † 1936 New Jersey).

Gordon Earle Moore (* 1929 San Francisco).

John Nepomuk Morack (Morak, Morach, * 2 September 1730/31 Ljubljana; SJ 28 October 1748; † 9 January 1807 Radomlje).

Maximilian Morautscher (* 1721; † 1806).

Henry More (Heinrich Morus, * 1614; † 1687).

Giambattista Morgagni (* 1682; † 1771).

John Pierpont Morgan (* 1837; † 1913).

John Pierpont Morgan (Jack, * 1867; † 1943).

François Auguste Morren (* 1804 Bordeaux; † 1870 Marseille).

Mario Morselli (* 1922 Milano), son of Giovanni Morselli (* 1875 Concordia sulla Secchia, Province of Modena, Emilia-Romagna; † 1958 Milano).

Henry Morton (* 1836 New York; † 1902 New York).

Sebastiano Fox Morcillo (Fox-Morzillo, Foxius Morzillus, * 1526/1528 Sevilla; † 1559/1560 at sea).

Mihail Jakovlevič Mogoškin (Михаил Яковлевич Морошкин, * 1820 село Андреевское Бежецкого уезда Тверской губернии (village Andreebskoe in Bezhetsky Uyezd of the Tver Governorate); † 1870 Petersburg (Санкт-Петербург)).

Anton Albert baron Moscon (* March 18, 1782 Graz; † January 16, 1822), a well-known pomologist, planted a large nursery in Graz with a school, and later in Pišece by Brežice where he founded a school in the castle and paid a teacher.

Josip Moser (* 1942 Dubrovnik).

Rudolf Ludwig Mössbauer (* 1929 Munich; † 2011 Grünwald).

Ottaviano Fabrizio Mossotti (* 1791; † 1863).

Motoki Ryōei (Yoshinaga, 本木 良永, * 1735; † 1794).

Motoki Ryōi (本木庄太夫良意, * 1624; † 1697).

Neville Francis Mott (* 1905 Leeds; † 1996).

Albert Johann Mosetig knight Moorhof (Mosetich, Mozetič, * 1838 Trieste; † 1907 in Danube by Vienna).

Nevill Francis Mott (* 1905 Leeds; † 8 August 1996).

Louis-Toussaint de la Moussaye (* 1778 Rennes; † 1854, Paris).

James Wallace Moyer (* 16 August 1919 Syracuse, New York) obtained his PhD in physics at Rutgers University in 1948 for his work as research associate to Knolls Atomic power lab of GE in Schenectady, eastern New York in 1946-1955. After 1963 he was a director of applied research Autonetics division of North American Aviation research center at Anaheim, California while residing in Santa Barbara.

Miran Mozetič (* 1961).

Dušan Mrkić (Dan Mrkich, Душан Мркић, * 1939 Budačka Rijeka 20 km south of Karlovac in Croatia; † 2005 Canada).

Ferdinand von Mueller (* 1825; † 1896).

Franc Mühlpacher (Mühlbacher, Mühlbacher, Millbacher, * 16 October 1744 Ljubljana; SJ 18 October 1760 Vienna; † 1826 Stanisławow (Ivano-Frankivsk) in today's Ukraine).

Vladimir Muljević (* 1913 Zagreb; † 2007 Zagreb).

Matt Mullenweg (* 1984).

Carl Heinrich Florenz Müller (* 1845; † 1912 Hamburg).

Emil Müller (* 22 April 1861 Landskron (Lanškroun); † 1 September 1927 Vienna).
Filip Müller (Philip, * 1613 Graz).

Franz Müller (Beckenbauer, * 1838; † 1906).

Franz Müller (* 1859; † 1921).

Johann Christoph Müller (* 1673; † 1721).

Johann Heinrich Müller (* 1671; † 1731).

Johann Heinrich Jakob Müller (* 1809, Kassel, Westphalia; † Freiburg im Breisgau).

Louis Müller-Unkel (* 1853 Schmalenbuche (now part of Neuhaus am Rennweg); † 1938 Rudolstadt in Thüringen).

Peter Müller (* Koblenz; † 1858 Berlin).

Alfonz Müllner (* 1840 Velikovec; † 1918 Vienna).

Georg Wilhelm Muncke (Munck, Munke, * 1772 Hilligsfeld; † 1847 Großmehlen).

William Murdock (Murdoch, * 1754 Bellow Mill; † 1839 Soho).

Jakob Murko (* 7 July 1851 Ptuj; † 16 February 1916 Graz Schlossberg (Castle Hill) no. 36).

Vladimir Murko (* 1906 Graz; † 1986 Ljubljana).

Maria Meichenič widow Malleg married Murko (Majhenič, * 9 November 1838 Maribor Jahringtal parish Bezirk; † 27 March 1916 Graz parish Heilige Blut).

John Murray (* 1778 Edinburgh; † 22 July 1820 Edinburgh).

Pieter van Musschenbroek (* 1692; † 1761).

Johannes Joosten van Musschenbroek (* 1660; † 1707).

Samuel van Musschenbroek (* 1639; † 1681).

François Georges Mustel (* 1719 Rouen; † 1803 Rouen).

Nicolas-Alexandre Mustel (* 1724/1736; † 1804/1806).

Anton Muszka (* 1719; † 1790).

Igor Mušević (* 1954 Ilirska Bistrica) drummer of the ethnorock band Begnograd turned Blinc's successor head of F5 department at IJS by research of self-assembly in nematic liquid crystalline colloids.

Drago Mušič (* 1899 Novo mesto; † 1993 Maribor).

N

Andrea Naccari (* 1841 Padua; † 1924 Torino).

Josef Wilhelm Nagler (* 1901 Vienna; † 1990 Vienna), published 1950-1968 as editor of the Viennese *Blätter für Technikgeschichte* and the director of Technischen Museums Wien in 1950-1966.

Tanaka Masayuki Nakagaki (* 1929 Fukuoka Prefecture; † 2008 Kyoto).

Tsuko Nakamura (Nakamura Tsuko, 中村 土, * 1943 Seoul in then Japanese Korea).

Shigeru Nakayama (中山茂, * 1928; † 2014 Tokyo).

Hantare Nagaoka (* 1865; † 1950).

Aleksander Nagy (* 1834 Ptuj; † 1909 Maribor).

Robert Nahrwold (* 1850) PhD at Friedrich-Wilhelms-Universität Berlin in July 1876, then teacher and director of the Berlin Grammar School (Gymnasium) and collaborator at Helmholtz's Berliner Institute of Physics.

Slobodan Nakićenović (* 1916; † 1996 Vienna).

Ananth Naman, studied for Ph.D. at department of Materials Science & Engineering University of Florida in 1904-1997 in collaboration with

Department of Energy Office of Energy Research
Oak Ridge National Laboratory Tennessee- Now
CTO, VP Asia Pacific at Cabot Microelectronics in
Xuhui District, Shanghai, China.

Julius Nardin (* 1877; † 1959)-

Friedrich Narr (* 1844 Würzburg; † 1893).

Johann August Natterer (* 1821; † 1901).

Claude-Louis-Marie-Henri Navier (1785 Dijon-1836
Paris)

Nazzaro Nazzari (Nazario Nazari, * 1723/4, Venice;
† after 1793).

Jacques Necker (* 1732; † 1804).

Joseph Needham (* 1900 London, England; † 1995
Cambridge).

Christian Ernst Neeff (* 1782; † 1849).

Franc Neger (* 1859; † 1944).

Josip Nejedli (Nejedly, Johann Necedlý, * 1821
Prague; † 1919 Ljubljana).

Johan Christian Nelkenbrecher († 1760).

Vinko Nemanič (Vincenc), head of Vacuum lab at
F4 department of IJS.

Miha Nemevšek, staff member/senior scientist at the
high energy Particle physics group of the Theoretical
Physics Department at the Jožef Stefan Institute.

Herman Walther Nernst (* 1864; † 1941).

Henri Nestlé (Heinrich Nestle, * 1814 Frankfurt am
Main; † 1890 Glion by Montreux in Switzerland).

Eugen Netoliczka (* 1829; † 1889).

Joseph Chrysostom Neugebauer (* 1706
Franckenstein (Ząbkowice Śląskie south of
Wroclaw) in Silesia; SJ 1729 Vienna; † 1759
Beijing).

Carl Gottfried Neumann (* 1832; † 1925).

Franz Ernst Neumann (* 1798; † 1895).

Johann Philip Neumann (* 27 December 1774
Třebíč (Trebitsch, Trebiž), north of Vienna, west of
Brno in Moravia, † 1849 Vienna).

Louise-Marie de Gonzague princess Nevers
(Gonzaga, * 1611; queen 1646; † 1667).

Simon Newcomb (* 1835 Wallace, New Scotland; †
1909).

Thomas Newcomen (* 1663; † 1729).

John Alexander Reina Newlands (* 1838; † 1898).

John Frederick Newman (* 1783 South Londoner
Peckham, Surrey; † 1860 borough in Northwest
London of Camden, Middlesex).

Isaac Newton (* 1642; † 1727).

John Newton (* 1759; † 1844).

William Newton John's son and successor.

Janez Nexinger (Johann, * 1641 Schwanenstadt in
Upper Austria; † 1729).

Edward Leamington Nichols (* 1854; † 1937 West
Palm Beach).

Ernest Fox Nichols (* 1869 Leavenworth in Kansas;
† 1924).

John William Nicholson (* 1 November 1881,
Darlington; † 3 October 1955).

William Nicholson (* 1753; † 1815).

William Nicol (* 1770; † 1851 Edinburgh).

Alexander McLean Nicolson (Nicholson, * 1880
Uruguay; † 2 February 1950 New York).

Jens Rud Nielsen (* 1894 Copenhagen; † 1979
Norman Oklahoma) Bohr's student who immigrated

to the United States in 1922 to become a physicist at the University of Oklahoma in 1924-1971.

Keld Nielsen, Head of Institute for the History of Science at Aarhus University, Denmark, later at Denmark Museum in 2007.

Christian Nieper (* 1819 Braunschweig).

Jacob Joannes Wencheslav Dobrzensky de Nigro Ponte (Schwartzbrug, Cherného Mostu, 1623; † 1697).

baron Feodor Nikolić (* 1836; † 1903).

Paul Nipkow (* 1860; † 1940).

Jun-ichi Nishizawa (西澤 潤一, Jun'ichi, * 1926 Sendai; † 2018 Sendai).

Vladimir N. Njegovan (* 1884 Zagreb; † 1971 Zagreb).

Alfred Nobel (* 1833; † 1896).

Leopold Nobili (* 1784; † 1835).

Charles Nodier (* 1780; † 1844 Paris).

Etienne Noël (* 1581; † 1659).

Lodovico count Nogarola (* 1490/1491 Verona; † 1558/1559 Verona).

Floris Nollet (Florise, * 1794 Élouges in Belgium; † 1853 Elsene in Belgium) professor in Brussels.

Jean-Antoine Abbé Nollet (* 1700; † 1770).

St. Norbert (Gennep, * abt. 1075 Xanten-Magdeburg; † 1134).

John Norris (* 1954).

Edwin Fitch Northrup (* 1866 Syracuse; † 1940).

Wayne Buckles Nottingham (* 1899 Tipton, Indiana; † 1964, Bloemendaal, Netherlands)

Jožef Andrej Nowak (Novak, Novakh, Baptized as Josef, * 1750 Gorizia; † 15 April 1888 Stična).

Campanus of Novara (* 1220; † 1296).
Robert N. Noyce (* 1927; † 1990).

Pierre Des Noyers (* 1608; † 1693).

Črtomir Nučič (* 1909; † 1969 Ljubljana?).

Pedro Nuñez (Nonius, * 1492 Alcazar del Sol; † 1577 Coimbra).

David E. Nye (* 1946 Boston), professor emeritus at University of Southern Denmark (at Odense, Copenhagen, etc.)

O

Guglielmo Oberdan (Wilhelm Oberdank, * 1858 Trieste; † 1882 Trieste).

Albert von Obermayer, colonel (* 1844; † 1915).

Pavel Obersteiner (Steiner, * about 1480 Radovljica; † after 1544).

Robert Obrul from Oplotnica, professor of history and German language, founding member of the local vocal ensemble Sonus.

William Ockham (* 1280/1285 Ockham; † 1347/1349 München).

Anton Ocvirk (* 1907 Žaga by Bovec; † 1980).

Benedetto Odescalchi (* 1611 Como).

Gottlieb S. Oehrlein, from 2000 taught at A. James Clark School of Engineering of the University of Maryland involved in researches of Low-Temperature Plasma Surface Interactions, Nanoscale Graphitic, Film Formation, Atomic Layers, and Etching by atmospheric-pressure plasma jet.

Hans Christian Oersted (* 1777; † 1851).

Ogata Kōan (緒方 洪庵, Ogata Koreaki, * 1810; † 1863 Edo).

Alfred Ogris, retired director of Land Archive of Carinthia (Kärntner Landesarchives).

Russell Shoemaker Ohl (* 1898 Pennsylvania; † 1987 California).

Lorenz Oken (* 1 August 1779; † 11 August 1851).

Tanomi Okutsugu (田沼意次, * 1719; † 1788).

Mark Oliphant (* 1901 Adelaide; † 2000 Canberra).

Jean-Philippe-Augustin Ollivier (* 1739; † 1788).

Axel Ragnar Olsen (* 1889 Halsingborg Sweden; † 1954 Berkeley), Chemical laboratory of the university of California.

Karol Olszewski (* 1846; † 1915).

Jabbo Oltmanns (Ottmans, * 1783 Wittmund (Ostfriesland); † 1833 Berlin).

Lucas Opfermann (* 1690 Fulda; SJ; † 1750 Fulda).

Julius Robert Oppenheimer (* 1904 New York; † 1967 Princeton).

Alojzij Oražem (* 1932 Sodražica; † 2017).

Nicolo d'Orbellis (Dorbel, Dorbellus, d'Orbelles, * abt. 1400 around Angers in Western France; OFMconv; † Abt. 1475 Rome).

Maria Theresa Wintershofen married Oršić (* about 1665; † 1700).

Abraham Ortelius (* 1527; † 1598).

Frederik III of Ortenburg († 1418).

Otto V Ortenburg (* 1292; † 1343).

Otto VI Ortenburg (* 1338; † January 29, 1374).

Mario Osana (Marij, * 1880; † 1958).

Milan Osredkar (* 19 October 1919 Ljubljana; † 2003).

Radko Osredkar (* 1945).

Uči Fajgelj married Osredkar (* 31 August 1927 Kred by Kobarid).

Niko Ottowitz, professor of physic and mathematic at Slovenian Grammar School in Klagenfurt.

Franciscus de Oviedo (* 1602 Madrid; SJ; † 1651).

Friedrich Wilhelm Ostwald (* 1853 Riga; † 1832 Leipzig).

Jacques Ozanam (* 1640; † 1718 Paris).

P

Karl Adolf Paalzow (* 5 August 1823 Rathenow; † 1908 Berlin).

Janez Krstnik baron Paccassi (Johann Baptist, * 1758, Gorizia; † 1818 Vienna).

Nikolai Frančišek Leonard Paccassi (Nikolaus Franz Leonhard, * 1716 Viennese Neustadt; † 1790 Vienna).

Stefano Pace (* 1695 Malta; SJ Parma?; OFM third order Malta?; † 1735 Malta).

Charles Grafton Page (* 1812; † 1868 Washington D.C.).

Franc Mihael Paglovec (* 1679 Kamnik; † 1759 Spodnji (Lower) Tuhinj).

Emanuel Anatoljevich baron von der Pahlen (Барон Эмануэль Анатольевич фон дер Пален, * 1882 Peterhof by St. Petersburg, Russia; † 1952 Basel).

Peter Aleksevich count von der Pahlen (Peter Ludwig Graf von der Pahlen, Пётр Алексеевич фон дер Пален (Пáлен), Pëtr Alekséevič Pálen (Palen), Pyotr Alexeyevich, * 1745, Palms Manor (now Palmse); † 1826, Mitau (now Jelgava)) a Baltic German courtier and general playing a pivotal role in the assassination of the Emperor Paul as the Military Governor of Sankt Petersburg.

Jože Pahor (Joko, * 1933; † 2017).

Michael Paintner (* 1753; † 1826).

Adriano De Paiva (* 1847; † 1907).

Janko Pajk (* 1847; † 1899).

Carl Pallasman (* 1840 Schlotten in Bohemia).

Cardinal Francesco Maria Sforza Pallavicino (Pietro Pallavicini, 1607 Rome; † Rome).

Luigi Palmieri (* 1807; † 1896 Naples).

St. Pancratius (* 289; † 12 May 303/304 Rome).

Frederic Paneth (Fritz, * 1887 Vienna; † 1958 Mainz).

Giovanni Jacobo Panici (* 1657; † 1716).

Matjaž Panjan (* 1980).

Peter Panjan (* 1957).

Milan Panajotović († before 1936).

Giuliano Pancaldi (* 1946 Italy), professor at Bologna University.

knight Lambert Pantz (* 18 August 1835 Tržič; † 3 February 1895 Fieberbrunn in northeast Tyrol).

Joseph Panzi (Giuseppe Pansi, P'an T'ing-Tchang, Jo-Ché, * 1734 Cremona or Florence; SJ Genova (Genes); † before 1812 Beijing).

Denis Papin (* 1647; † 1713).

Mihael Papler (* 1621 Škofja Loka in Carniola; SJ 1639 Vienna; † 1670 Loreto in Italy), 9th rector of Rijeka (Fiume) Jesuitical school in 1667-1670.

Jean-Noël Paquot (* 1722 Florennes; † 1803).

Aureolus Teofrastus Bombastus von Hohenheim Paracelsus (Paracelz, * 1 May 1493; † 24 September 1541 Salzburg).

Dominique Parrenin (Parrenin, Pa To-ming K'e-an, * 1 September 1665 Grand-Russey; SJ 1 September 1685; † 20 September 1741 Beijing).

Georg Friedrich Parrot (* 1767; † 8 July 1852).

Charles Algernon Parsons (* 1854 London; † 1931 Jamaica).

Paul Maria Partsch (1791-1856).

Blaise Pascal (* 1623; † 1666).

Etienne Pascal (* 1588; † 1651).

Gilberte Pascal (* 1620; † 1668).

Louis Pasteur (* 1822; † 1895).

sir Clifford Copland Paterson (* 1879; † 1948).

Samuel Paterson (* 1728; † 1802).

Karl Pauer (* 1847 Ljubljana).

Ana married Pauer (* 1850 Šentjernej).

Wolfgang Pauli (* 1900; † 1958).

Aimé Henri Paulian (* 1722; SJ; † 1801).

Alojz Paulin (Pavlin, * 1930 Podbrezje in Franckova house).

Jean Paulus (* 1710 Vergaville; SJ; † 1781).

Snježana Paušek married Baždar (* 1950 Brčko in Bosnia and Herzegovina).

Gerald L. Pearson (* 1905 Salem, Oregon; † 1987 Portola Valley, California) was raised as a Quaker.

Rendel Sebastian Pease (Bas, * 1922 Brunswick Walk, Cambridge; † 2004 West Ilsley, Berkshire), the son of geneticist Michael Stewart Pease († 1966) and his wife the great-great-great-granddaughter of the potter Josiah Wedgwood. Rendel directed the Culham Laboratory for Plasma Physics and Nuclear

Fusion and 1968–1981 and headed the British chapter of Pugwash against nuclear bombings.

Leopold von Pebal (* 1826; † 1887).

Ferdinand Peche (* 1820 Pisek in southern Bohemia; † 1898 Innsbruck).

Giuseppe Pecis (* 1716 Milan; † 1799 Cinisello).

Charles Fletcher Peck (* 1834 Quebec, Canada; † 1890 Asheville, Buncombe County, North Carolina), Tesla's New York City attorney.

Adolf Pečovnik (* May 25, 1883 Sv. Lenart).

Carl Peer (Karl, Karel, * 1697; † 1776).

Adam Peiperl (* 1935 Sosnowiec, Sosnowiec, Silesian Voivodeship, Poland; † 2019 Silver Spring, Maryland), Jewish translator and videographer of Kinetic Polarized Light Sculptures.

Nicolas Claude Fabry de Peiresc (* 1580; † 1637).

Geminiano Pellegrini (* 1845 Koper).

Theodor baron Pelichy and Turksweert (* 1741; † 1811).

Frans Michel Penning (* 1894; † 1953 Utrecht).

Benedictus Pererius (Valentin, * 1535 Ruzafa near Valencia; SJ; † 1610 Rome).

Bernhard Perger (* about 1640 Ščavnica in Slovenske gorice (Stanz); † about 1502 Vienna).

André Pereira (徐懋德, * 1689; † 1743).

Francisco Pereira (* 1607 Lisbon; SJ 1622; † China).

Florin Périer (* 1605; † 1672).

Andrej Perlah (Perlach, Perlachius, * 1490 Svečina by Maribor (pri Mariboru); † 11/19 June 1551 Vienna).

Jean Pernet (Johannes, * 1845 Bern; † 1902 Zürich).

Markus Pernhart (* 1824; † 1981).

Hans Pernter (* 3 October 1887 Vienna; † 25 July 1951 Bad Ischl).

Jean Baptiste Perrin (* 1870 Lille; † 1942 New York).

John Perry (* 1850 Garvagh in Londonderry; † 1920 London).

Constantin Perskyi (Perski, КОНСТАНТИН ДМИТРИЕВИЧ ПЕРСКИЙ, * 1854 Tver gubernorate; † 1906).

Milan Pertot (* 1884 Trst; † 1967 Ljubljana).

Eligio Perucca (* 1890 Potenza; † 1965 Rome).

Dionigi Petavio (* 1583; SJ; † 1652)

Adelmo Antonio count Petazzi of Novigrad (Petazi di Castel Nuovo (& San Servolo island in the Venetian Lagoon), Petaci, Petačić, * abt. 1670; † 1733).

bishop Leopold Hanibal Josef Petazzi (* 1703; † 1772).

John Baptist Petek (Pettenegh) of Ljubljana.

Giulio Peterin (Julije, Julius, * 1846).

Boris Matija Peterlin (* 4 July 1947), the son of Anton Peterlin (* 1908).

Anton Peterlin (* 1866 Ljubljana-Šiška; † 1912).

Anton Peterlin (* 25 September 1908 Ljubljana; † 24 March 1993).

Ernest Peterlin (* 1903 Ljubljana; † 20 March 1946).

Radivoj Peterlin - Petruška (Franc, * 1879 Kamnik; † 1938 Kamnik).

Tatjana Peterlin married Neumaier (Tanja, * 18 March 1945).

Anton Peterlin (* 1908; † 1993).

where Mihael Peternel (* 1808, the Laniše farm in the then parish of Nova Oselica (Neuoslitz); † 1884).

Alexis Thérèse Petit (* 1791; † 1820).

Pierre Petit (* 1594; † 1677).

Tomislav Petković (* 1951 Šibenik), physicist and philosopher at Zagreb University.

Francesco Petrarca (Petrarch, * 1304; † 1374).

Joseph Leopold Baron Petrasch (Petráš, * 1714 Slavonski Brod; † 1772 Neuschloß in Moravia).

Angelus Petricca (Petricca de Sonneno, * 1601 Sonnino in Central Italy of then Campagna e Marittima; OFMconv; † 1673 Rome (less likely 1650).

William Petrie (* 1824 Kings Langley, Hertfordshire; † 1901 Bromley, Kent)

Vasilyi Vladimirovich Petrov (Василий Владимирович Петров, * 1761 Obojan; † 1834).

Henricus Petrus (Henric Petri, Heinrich Petri, * 1508 Basel; † 1579 Basel) leading printer in Basel.

Adam von Pettenegkh Pöttickh (Petek, * 1640/1645; † 1705).

Hans Petterson (Pettersson, * 1888; † 1966).

William Petty 2nd earl of Shelburne (* 1737 Dublin; † 1805).

Espirit Pezenas (Pézenas, * 1692 Avignon; SJ; † 1776 Avignon).

Christian Heinrich Pfaff (* 1773 Stuttgart; † 1852 Kiel).

Jože Pfeifer (* 1919 Ljubljana; † 1991 Idrija).

Gotfrid Pfeiffer (Gottfried Pfeifer, Pfejfer, Fajfar, * 5 March 1707 Radovljica areas at upper Carniola (Gorenjska), maybe Sorica; OMFConv 11 March 1724; † 1775/1780 Novo mesto).

Leopold Pfaundler von Hadermur (* 1839 Innsbruck; † 1920 Graz).

Anton Pillebois flourished as Viennese University's official editor of the paperback schematism in 1793-1824.

Anton Frederik Philips (* 1874; † 1951).

Friedrich Philips (Benjamin David, * 1830; † 1900).

Gerard Leonard Friderik Philips (* 1858; † 1942).

Robert Philips (* 1826; † 1906).

Abbé Jean Picard (* 1620; † 1682).

Karl Pichelmayer (* 6 August 1868 Bern village of municipality Bruck an der Mur; † 23 January 1914 Vienna).

Franz Pichler (* 1936 Thalgau by Salzburg).

Greenleaf Whittier Pickard (* 1877 Portland, Maine; † 1956 Newton, Massachusetts).

Giovan Francesco Pico della Mirandola (* 1463; † 1494).

Marc Auguste Pictet (* 1752; † 1825).

Raoul Pierre Pictet (* 1846; † 1929).

Lovro Pičman (* 1929 Ljubljana).

John Robinson Pierce (* 1910 Iowa; † April 2, 2002 California).

Victor Pierre (* 1819; † 1886).

Francesco Pifferi (* about 1548 Monte San Savino in Tuscany; O.S.B. Cam; † after 1604).

Gjuro Pilar (* 1846; † 1893).

Benedikt Pillwein (Benedict, * 1779 Obersulz in Lower Austra; † 1847 Linz).

David Pines (* 1924 Kansas City; † 2018 Urbana).

Hieronim Pinoccio (* 1612 Lucca; † 1676).

Luka Pintar (* 1857 Hotavlje in Poljanska dolina; † 1915 Ljubljana).

Vasilij Nikolaevič Pipunov (Василий Николаевич Пипунов) published on history of chronometers in 1955-1986.

Marcello von Pirani (Manfred, * 1880; † 1968).

Edo Pirkmajer (* 1932).

Nikolaj Pirnat (* 1903; † 1948).

Ángela Piskernik (* 1886 Carinthia; † 1967).

Franz Joseph Pisko (Josef, * 1827 Rousínov (Neuraußnitz), Moravia; † 1888 Bad Aussee, Styria), taught geography and physics as director of Higher Real School Vienna- Sechshaus in 1872-1883.

Nikolai Georgievich Piskunov (Николай Георгиевич Пискунов, * 1886; † 1941) graduated from Physics and Mathematics Department of Saratov University where he worked fluent in European and ancient languages in 1920s.

Vladimir Pištalo (* 1960 Sarajevo).

Antonio Pizzarello (* 1846 Koper; † 1933 Macerata).

Antonio Pizzarello (* 1869 Koper).

Ugo von Pizzarello (* 1877 Macerata; † 1955).

Jean Plana (Giovanni Antonio Amedeo, * 1781; † 1864).

Plato (* 427 BC Athens; † 347 BC).

Lyon 1st Baron Playfair (* 1818; † 1898).

Josip Plemelj (* 1870; † 1967).

Joannes Baptista Planck (* 1696 Neumarkt in der Oberpfalz; † 1765 Munich).

Max Planck (* 1859; † 1947).

Johann Plank (* abt. 1845 Habsburg monarchy), High School professor in 1873 with some publications in his school Yearly (Jahresberichte).

Josef Plank (* abt. 1846 Hall in Tirol), holder of a war medal (Besitzer das Kriegsmedial (Kriegsmedialle)) as Gymnasium student soldier in war of 1859. During final years of his Viennese studies he served as supplied professor (Supplent, Amtskandidat) helping Karl Exner's classes of mathematics at Viennese Akademischen Gymnasium in 1868/69 and at Staats Gymnasium at third district of Vienna (III. Bezirke Wien) up to 1 September 1875. He researched as J. Stefan's assistant in Vienna from June 1875 until 1877. Then Plank became a full ordinary professor of mathematics and physics as a colleague of professor of philosophical propaedeutic Latin and German languages Janko Pajk in higher classes of k.k. Franz-Joseph-Gymnasium in Vienna at 1st Bezirk at Hegelgasse no. 3 from 1 September 1875 until Plank's retirement on 31 July 1905 in the schoolyear 1904/1905. That Grammar school (Staats-Gymnasium in der Inneren Stadt Wien, now Stubenbastei) was established on 4 October 1872 with that official name introduced on 21 April 1879. After 1921 it was called Bundesrealgymnasium Wien 1. Plank was probably the son of the portrait-history painter Josef Plank (* 1815 Hall in Tirol; † 1901 Vienna) (*Jahres-Bericht über das k. k. Akademische Gymnasium in Wien: für das Schuljahr 1868-1869, 25-26; Achter Jahresbericht über das k.k. Franz-Josephs Gymnasium in Wien, 1882, Vienna, p. 31; Sechzehnter Jahresbericht über das k.k. Franz-Josephs Gymnasium, 1890, p. 1; Fünfundzwanzigster Jahresbericht über das k.k. Franz-Josephs Gymnasium, 1899, p. 2; Einunddreißigster Jahresbericht über das k.k. Franz-Josephs Gymnasium, 1905, p. 2; Zweiunddreißigster Jahresbericht über das k.k. Franz-Josephs Gymnasium, 1906, pp. 1-2, 16; 18. Jahresbericht über das k.k. Staats Gymnasium im III. Bezirke in Wien für das Schuljahr 1873*).

Leopold Franz Ritter von Plappart (* 1744 Styria (Vransko?); † 29 January 1805 castle Spielfeld (Špilje) on Austrian side of Slovenian border or Maribor), Viennese medicinal PhD on Antimony in 1765, Land-Protomedicus of Styria after the death of

Sigmund R. Ritter von Katharin († 1778), related to another physician Joachim Friedrich Plappart von Frauenberg (* 13 March 1753 Vransko (Franz) in Lower Styria; † 1845 Graz).

Joseph Plateau (* 1801 Brussels; † 1883 Ghent).

Franjo Plentaj (* 1850/1851 probably in Polish Galicia; † November 24, 1901).

Georgius Gemistus Plethon (Pletho, Γεώργιος Γεμιστός, * 1355 Constantinople; † 1452/54).

Wilhelm Heinrich Theodor Plieninger (* 1795 Stuttgart; † 1879 Stuttgart) the Stuttgart palaeontologist.

Pliny the elder (* 23/24; † 79).

Noel Antoine Pluche (* 13 November 1688 Rems; † 19 November 1761 Paris).

Julius Plücker (* 1801; † 1868).

Friedrich Carl Alwin Pockels (* 1865; † 1913).

Bogdan Podgornik, in 1977-2007 specialist for the precise mechanics at IEVT in Ljubljana later adjoined to the IJS.

Rudolf Podgornik (Rudi, * 1955 Ljubljana).

Nataša Podgoršek (* abt. 1976), professor at Faculty of Education (Pedagoška fakulteta) of Maribor University.

Roman Grigorievich Podolny (Роман Григорьевич Подольный, * 1933 Moscow; † 1990 Moscow).

Johann Christian Poggendorff (* 1796; † 1877).

Janez Krstnik Pogrietschnig (Johann Baptist Pogrietsnig, Pogričnik, * 1722 Radiše (Radsberg) 10 km southeast of Klagenfurt; SJ 1745 Trenčín; † after 1782).

Robert Wichard Pohl (Weichardt, * 1884 Hamburg; † 1976 Göttingen), director of physics institute in Göttingen after 1920.

Karl Wilhelm Pohlke (* 1810 Berlin; † 1876 Berlin).

Jules Henri Poincaré (* 1854; † 1912).

Lucien Poincaré (* 1862; † 1920), physicist, brother of Raymond and cousin of Henri.

Raymond Poincaré (* 1860; † 1934), French Prime Minister (President).

Aloys de Poirot (Louis Antoine, 賀清泰, Hè qīngtài * 1735 Lorraine; SJ; † 1813 Beijing).

Jean Leonard Marie Poiseuille (* 1799; † 1869).

Denis Poisson (Simeon Denis, * 1781; † 1840).

Joseph Polák (Ede József, Polak, * 1816 Dolný Prial (Alsópél) in Nitra region of southwest Slovakia; Piarist monk; † 1892 Budapest). After teaching at Debrecen, Vác, Nitra, Banská Štiavnica (Schemnitz) and Timisoara, he came to Kecskemét as the director of the main grammar school in 1862. His scientific papers appeared in the bulletins of the Kecskemét high school (főgimnázium). His articles were also published by the local journal *Kecskeméti Lapok* in 1868-1950. His relative Eduard Polák (Pollak) taught and published about mechanics and physics in Piarist's Grammar School in Banská Štiavnica in 1843-1859.

Natalija Polenec (* 1965 Kranj), the director of Technical Museum Slovenia in Bistra in 2014-2020.

Christopher von Polhem (Polhammar, * 1661; † 1751 Stockholm).

Giuseppe Saverio Poli (* 1746 Molfetta; † 1825 Napoli).

Feodor Polikarpov-Orlov (Феодор Поликарпович Поликарпов-Орлов, * 1667/1672 Moscow; † 1731 Moscow).

Efim Mikhaïlovich Poliščuk (Ефим Михайлович Полищук, Polishchuk, * 1914 Kiev; † 1987).

Marco Polo (* 1254; † 1324).

Alexander Appolonovich Polumordvinov (Александр Аполлонович Полумордвинов, * 1874 Slobodskoy (Слободской) in modern Kirov oblast; † 2 December 1941 (by Gregorian calendar 1942) Kirov (Киров), previously Vyatka (Вятка) 900 km northeast of Moscow) taught mechanics, geometry, and drawing at Kazan Technical-Industrial School in 1898-1900, exhibited at Parisian *Exposition Universelle* in 1900, studied and worked in Petersburg until 1911, then in Kazan and Vyatka until his retirement on 30 November 1921.

marchioness de Pompadour (Jeanne Antoinette Poisson, * 1721; † 15 April 1764).

Mela Pomponius (* Tingentera/Cingentera in the gulf Algeciras) worked in 43.

Johann Heinrich Moritz von Poppe (* 1776 Göttingen; † 1854 Tübingen).

Viktor Ivanovič Popov (Виктор Иванович Попов, * 1895; † 1965).

Dragoslav D. Popović (Поповић, * 1926 Skorje; † 2013).

Vojin Popović (Војин Поповић, * 1914 Kragujevac; † 2008 Beograd).

Milentije Popović (Поповић, * 1913 Crna Trava in Serbia; † 1971).

Prince Janez Ferdinand Porcia (Portia, * 1606; † 1665).

Giovanni Battista dela Porta (* 1534/35; † 1615).

Janez Posch (OFMobs; † 3 January 1549 Ljubljana).

Jakob Pöschl (* 1828; † 1907 Graz).

Magdalena born Nömayr married Pöschl (* 1849).

Theodor Michael Friedrich Pöschl (* 1882; † 1955).

Viktor Pöschl (* 1910 Graz; † 1997 Heidelberg).

Victor Pöschl (* 1884 Graz; † 1948 Karlsruhe).

Herman Potočnik (Noordung, * 1892 Pula; † 1929).

Jožef Potočnik (Josef, * 1841 Zgornji Razbor near Slovenji Gradec; † 1894 Pula).

Claude Servais Mathias Pouillet (* 1791; † 1868).

Bogdan Povh (* 20 August 1932 Beograd).

Jože Povšič (* 1907 Dobrava pri Škocjanu; † 1985 Ljubljana).

Cecil Frank Powell (* 1903; † 1969).

Henry Power (* 1623; † 1668).

Edme Pourchot (Edmond, Edmundus Purchotius, * 1651 Poilly-sur-Tholon; † 1734 Paris).

Bernard Pourprix (* abt. 1945) professor of epistemology and history of sciences at the university of Lille and at IUFM (Institut Universitaire de Formation des Maîtres) du Nord - Pas de Calais of University Artois in northern France.

Jesuit Luis de Lossada Prada (* 1681 Quiroga; † 1748 Salamanca).

Juan Martínez de Prado (* early 17th century; OP Santa Cruz de Segovia; † 25 February 1668 Segovia).

Johannes P. Praetorius (* 1537; † 1616).

Georges Pralus (* 1940; † 2014).

B. S. N. Prasad of Department of Physics, Utkal University, 751004, Bhubaneswar, India, later joined the Department of Physics, Mysore University P. G. Centre Mangalagangothri, Konaje, 574152, Karnataka, India.

Velimir Pravdić (* 1931 Zagreb; † 2011 Zagreb), chemist and natural resource conservationist.

György Pray (Georgius, Georg, * 1723 Nové Zámky (Ěrsekújvár, Neuhäus[e]l, Novum Castrum) in southwestern Slovakia; SJ 1740 Vienna; † 1801 Pest).

Johann Joseph Prechtel (* 1778, Bischofsheim; † 1854, Vienna).

Erazem Predjamski (Luegg, Erasmus Lueger, † 1484 Luegg by Postojna (Lueg, Jama pri Postojni)).

William Henry Preece (* 1834 Bryn Helen, Caernarvon, Wales; † 1913).

Andrej Pregelj (* 30 June 1944 Ljubljana).

Peter Prelovšek (* 1949).

Primož Premzl teacher of physics and publisher in Maribor.

Martinus Prenner (* September 10, 1746 Škofja Loka).

Samuel Tolver Preston (* 1844; † 1917).

France Prešeren (* 1800; † 1849).

Janez Prešeren von Heldenfeld (Presheren, * Heldenfeld (Field of Heroes, Hraše) by Lesce na Gorenjskem; † 17 June 1814 parish Brezovica).

Johan Bapt de Presheren from Heldenfeld (Hraše) (lay brother Ivo Prešern, Janez Prešeren, Presheren, * abt. 1600 Hraše; OFMobs; † 13 January 1679 Sv. Leonard).

Janez Krstnik Presheren (Radmanstorfensis, * 1656 Hraše; † 1704 Ljubljana as the capitol provost and head of Academy Operosorum there).

Janez Krstnik Presheren (* 6 November 1680 Hraše; ennobled 1724 as de Preschern in Heldenfeld; † 19 April 1746 Ljubljana), Ljubljana Provost's relative and namesake, the sworn court lawyer of Carniola institutions as the highest official in Carniolan courts.

Joseph Mathias Prešeren von Heldenfeld (Hraše) by Radovljica (Matija Presheren, * abt. 1710 in Parish Radovljica; † after 1760 as a priest in Vransko).

Marija Prešeren (* 12 November 1837).

Johann Prettner (* 1812; † 1875).

Nikola Prica (Priča, * 1853 Korenica; † 1903 Karlovac).

Fraser Pierpont Price (* 1917; † 1977).

Derek John De Solla Price (* 1922 Leyton, UK; † 1983 New Haven), Yale Professor of the History of Science.

Joseph Priestley (* 1733; † 1804).

Gregor Primc (* 1984) Full-time researcher at Jožef Stefan Institute, Director of the firm Plasmadis with deputy director Miran Mozetič after 2018.

Ernst Pringsheim (* 1859; † 1917).

Peter Pringsheim (* 1881; † 1963).

Peter Probst (* 1699 Vienna; SJ 1718 Vienna; † 1750 Bavaria?).

William Prout (* 1785 Horton in Gloucestershire; † 1850 London).

Joseph Prudent Frédéric Herve de la Provostay (* 1812 Bréhier; † 1863 Algiers in Algeria).

Karl Przibram (* 1878 Vienna; † 1973 Vienna).

Francesco Puccinelli (* 1741; † 1809).

Anton Puchta (* 1851 Staré Sedlo in Bohemia; † 1903 Černovice (Чернівці)).

Rudolf Gustav Puff (* 1808 Holzbaueregg in western Styria; † 1865 Maribor).

Boris Jakovlevič Pugač (Jakovlevich Pugach, Борис Яковлевич Пугач) graduated from Kharkiv (Kharkov) State University as an "engineer-physicist" in 1968. In 1996 he defended his doctoral dissertation on "Observability and unobservability in natural science" focused to ontology, epistemology, phenomenology. In 2002 he received the academic title of Professor at the Department of Theory of Culture and Philosophy of Science in Kharkiv (Kharkov).

Janez Puh (Johann Puch, * 1862; † 1914).

Janez Puhar (* 1814; † 1864).

Simon Puljer (* 22 October 1832 Eberndorf).

Ivan Pavlovich Pului (Johann Puluĵ, Ів́ан Па́влович Пулю́й, Iwan Pawlowytsch, * 1845 Hrymailiv in Galicia, now in Ukraine; † 1918 Prague).

John Punch (Joannes Poncius Hyberno Corcagiensi, Pontius, Ponce, * 1599/1603 Cork in Ireland; OFM Leuven; † 26 May 1661 Paris (or 1672/73)).

Franz Georg Puntschart (* 1816; † 1872).

Franz Puntschart († 1890).

Mihajlo Pupin (* 1858; † 1935)

Georg Purbach (von Purbachius, Peurbach, Purbachius, * May 30, 1423; † April 8, 1461 Vienna).

Edward Mills Purcell (* 1912 Illinois; † 1997).

Karel Puschl (Karl Puschel, baptized Josef, * 1825 Wolfsbach in Lower Austria; OSB 1846 Seitenstetten; † 1912 Seitenstetten in Lower Austria 49 km east of Kremsmünster with the city Steyr in between) taught mathematics, physics, and other subjects at monastic Benedictine gymnasiums in Melk and Seitenstetten between 1853-1871, later gradually blind but continued to publish about aether. Puschl criticized Clausius in an important controversy about the basic theory of gases in *Wien.Ber.* in 1862 and 1863.

Ferenc Puskás (* 1848; † 1884).

Tivadar Puskás (* 1844; † 1893).

Gedeone Pusterla (pseudonym of Andrea Tommasich (Tomasich, Tomassich), * 1820 Koper; † 1898 Koper).

Lewis Robert Pyenson (* 1947 USA).

Pythagoras of Samos (* c. 570; † c. 495 BC).

Joseph Baron Quarin (* 1733; † 1814).

Jean Antoine Quet (* 1810; † 1884).

Adolphe Quetelet (* 1796 Ghent; † 1874 Brussels), the Belgian statistician.

Hermann Georg Quincke (* 1834; † 1924).

R

Franciscus Antonio de Raab (* 1755 Ritter von Raab zu Ravenheim, 1722 Klagenfurt; † 1783 Vienna).

Claude Rabuel (* 1669 Pont-de-Veyle; SJ 1685; † 1728 Lyon).

Philip D. Rack (* 1971), associate professor at the department of Materials Science and Engineering at the University of Tennessee, Knoxville in 1994.

Johann Radakovits (Radakovič, * 1877 Celje).

Michael Radakovits (Radaković, * 1866 Graz; † 1934 Graz).

Momčilo Radić, professor at Middle School (Srednja elektro-računalniška šola) in Maribor, published in 1982-1992.

Nikola Radić at Division of Materials Physics Department, Rudjer Bošković institute in Zagreb.

Janez Krstnik David Radio (* 23 February 1740 Gorizia; OFM 8 September 1760; † 26 January 1810 Ljubljana)

Piotr Wysz Radoliński Leszczyc (* abt. 1354; † 30 September 1414).

Leonard Bronisław Radziszewski (pseudonym Ignacy Czyński as Polish fighter for independence, * 1838 Warsaw; † 1914).

Janez Friderik von Rain (Joannes Frideric, * 1613; † after 1693).

Franc Henrik (Joseph) baron Raigersfeld (Rakovec, * 1697; † 1760).

Karel-Charles Franc Borgia Raigersfeld (* 1736; SJ; † 1800).

baron Michael Amadeus Janez Nepomuk Raigersfeld (Rakovec, * 1744; † 1783).

Chandra Kant Raju (* 1954 Gwalior, Madhya Pradesh in India).

Edward Granville Ramberg (* 1907 Firenze; † 1995), Quaker, Arnold Sommerfeld's student and translator of his *Electrodynamics* in 1952. Worked for RCA in 1935-1972, uncle of Nobel laureate molecular geneticist Mario Ramberg Capecchi (* 1937).

Agostino Ramelli (Augustin Ramell, * 1531 Ponte Tresa now in south Switzerland; † 1600 Paris).

Fran Ramovš (* 1890 Ljubljana; † 1952).

Jesse Ramsden (* 6/10/1735 Halifax; † 5 November 1800 Brighton).

Anton Ramšak, University of Ljubljana, Faculty of Mathematics and Physics.

Aquinas Ramutha (* 1787; † 1861).

John Randall (* 1905; † 1984).

Jørgen Randers (Jorgen, * 1945 Worcester, England), Norwegian.

Katherine Jones viscountess Ranelagh (* 1615; † 1691).

Richard Jones 1st Earl of Ranelagh (* 1641; † 1712), the Viscount Ranelagh between 1669 and 1677.

William John Macquorn Rankine (* 1820; † 1872).

Aleksandar Ranković (nom de guerre Marko, * 1909 Draževac, Serbia; † 1983 Dubrovnik, Croatia).

Heinrich Ranschburg (* 1860; † 1914).

Heinrich's son Otto Ranschburg (* 1900; † 1985).

René Rapin (* 1612; † 1687).

Fjodor Vasiljevich Rastopchin (* 1763; † 1826).

Gerhart Wolfgang Rathenau (* 1911 Charlottenburg; † 1989 Waalre).

Joseph Aloisius Ratzinger (* 1927 Marktl am Inn in Bavaria), the ruling pope Benedict XVI in 2005-2013.

Matjaž Ravnik (* 1953; † 2009).

John Ray FRS (* 1627; † 1705).

John William Lord Rayleigh (* 1842; † 1919).

Guillaume-Thomas-François abbé Raynal (* 1713; † 1796 Paris).

Marko Razpet (* 1949 Planina pri Cerknem).

Ksenia Aleksandrovna Razumova (Ксения Александровна Разумова, Xenia Razumova, * 1931).

Kirill Grigoevich count Razumovsky (Разумовский, * 1728; † 1803).

René Antoine Ferchault de Réaumur (* 1683; † 1757).

Marius Rebek (Marij, * 1889 Barkovlje (Barcola) suburb of Trieste; † 1982).

Valentin Redeschini De Haidovio (Radeschini, * 21 July 1746 Ajdovščina, OFM Cap 1765; † 4 February 1810 Gorizia).

Paul Aveling Redhead (* 1924 Brighton; † 2005 Ottawa).

Ignatius Redlhamer (Ignac Redelhamer, Redlhammer, * 1719 Erlauf in Lower Austria; SJ 1735 Vienna; † 1795 Eberndorf (Dobrla vas) in Carinthia) taught philosophy on Ljubljana in 1755-1756 as the younger brother of Bošković's fan Josef

Redlhamer (* 20 October 1713 Erlauf; SJ 1731 Vienna; † 9 July 1761 Vienna).

Ferdinand Redtenbacher (* 1809; † 1863).

Jacob Ferdinand Redtenbacher (* 1809; † 1863).

Joseph Redtenbacher of Kirchdorf, the father of Josef, Ludwig, and Wilhelm.

Josef Redtenbacher (* 1810; † 1870).

Ludwig Redtenbacher (* 1814; † 1876).

Wilhelm Redtenbacher, the Viennese physician.

Richard Furman Reeves (* 1936 New York; † 2020 Los Angeles) was an American writer, syndicated columnist, and lecturer at the Annenberg School for Communication at the University of Southern California in Los Angeles.

Erich Regener (* 1881 Wilczak in Poland; † 1955 Stuttgart).

Johann Müller Regiomontanus (* 1436; † 1476).

Pierre Sylvain Régis (* 1632; † 1707).

Henri Victor Regnault (* 1810; † 1878).

Noël Regnault (Noel, Natalis, * 1683; † 1762).

Franc Ludvik Regner knight Bleileben (Franz Ludwig Regnier Ritter von Bleyleben, Vjenceslav Nepomuk, * 1795 Chotimir in Brno city-district; † 23 December 1854 Nin by Zadar).

Anton Franz Reibenschuh (* 1840 probably a son of the innkeeper at Dogoše suburb of Maribor on the right bank of the Drava River (Lehndorf by Marburg) at east Maribor Pobrežje District; † 25 July 1902 Graz Grabenstrasse no. 28) published from 1867 to 1903 as the Assistant of chemistry at lab of Nikola Tesla's friend-professor Richard Maly at Graz Polytechnic (Technischen Hochschule zu Graz), professor at Higher Real school in Maribor, professor at Higher Real school Graz (Staatsoberrealschule) in 1875/1878-1891 and director there in 1895. He died as unmarried

Marienbrüder of tuberculosis followed by a funeral on 27 July at Graz-Graben church (Steiermark Rk. Diözese Graz-Seckau Graz-Graben Sterbebuch III 1867-1909. Page 618 no 84 (first)).

Günter Reich, former worker at Gaede Archiv at Vochemer Straße no. 9 in Köln.

Leonard S. Reich (Lenny) of Rutgers University, professor of administrative science and science-technology studies at Colby College at Mayflower Hill, Waterville, Maine from 1986 until his retirement in 2014.

Carl Ludwig baron Reichenbach (* 1788; † 1868).

Constance Reid (born Bowman, * 1918 Saint Louis; † 2010 San Francisco), the sister of mathematician Julia Hall Bowman Robinson (* 1919; † 1985) who paved the way to solution of Hilbert's 10th problem.

Friedrich Reinitzer (* 1857 Prague; † 1927 Graz).

Wenceslaus Laurentius Reinner (Václav Vavřinec Reiner, * 1689; † 1743).

Philipp Reis (* 1834 Gelnhausen; † 1874 Friedrichsdorf).

Matej Reiser (Matevž, * 1830 Weilersbach in Baden; † 1895).

Otmar Reiser (Othmar, * 1792 Villingen in Schwarzwald; † 1868 Maribor).

Joseph Reisner (Josip, * 1875; † 1955).

Branko Reisp (* 1928 Žiri; † 2009 Ljubljana).

Eugen Reisz (Eugen Reiss, Eugen Reiß, * 1879 Budapest; † 1957).

Anton Emil Reithammer, Ptuj based apothecary, published in 1865-1870, meteorological observer at Ptuj (Pettau) station in 1864-1874.

Max Reithofferplatz (* 27 October 1864 Vienna, † 10 March 1945).

Edmund Reitlinger (* 1830 Pest; † 1882 Vienna) as a professor of physics at the Viennese High School of Technology taught Rudolf Steiner. For many years Reitlinger edited the Natur- und Völkerkunde (nature and ethnology) section of the Viennese *Neuen Freien Presse* (New Free Press).

Leopold Rembold (Ludwig, * 1785/87 Dietenheim in Baden-Württemberg; † October 4, 1844 Vienna).

Johann Remmelin (* 1583 Ulm; † 1632 Augsburg).

Maja Remškar (* 1960 Ljubljana).

Alojzija Renko married Markič (Markitz, † 1962).

Anton Renko († 1968).

Franc Renko († 1982).

Janez Renko

Jera Renko (* March 14, 1907).

Ljudmila Renko married Haldane (Mila translated as People's pleasure, * 24 December 1919 Borovlje (Ferlach); † August 2016).

Pepi Renko

Theresa Renko married Scheiber († 1998).

Peter Resch († after 1918).

Josef Ressel (* 1793; † 1857).

Joseph Friedrich baron Retzer (* 1754 Krems an der Donau; † 1824 Vienna).

Carlo de Reutter (friar Marian, * 1734; Cistercian; † 1805), violinist, the eldest son of the Viennese composer George Reuter (* 1708; † 1772).

Anton Reviczký (Antal Reviczky, Reviczki, * 1723; SJ; † 1781 Trnava).

Emil du Bois-Reymond (* 1818; † 1896).

Jean F. Reynier (* 1730).

Jean Louis Antoine Reynier (* 1762 Lausanne; † 1824 Lausanne).

general Jean Louis Ebénézer Reynier (* 1771 Lausanne; † 1814).

Osborne Reynolds (* 1842; † 1912).

Igor Aleksandrovich Rezanov (Игорь Александрович Резанов, * 1927 Dvoryanskoe at Syzransky Uyezd of Simbirsk Governorate (Дворянское Сызранского уезда Ульяновской губернии); † 2006 settlement Kljazma in Pushkinsky District at Moscow Oblast (Клязьма, пос. Клязьма Пушкинский район), Doctor of Geological and Mineralogical Sciences, chief researcher at the Institute of the History of Natural Science and Technology named by S.I. Vavilov at Russian Academy of Sciences (RAS, РАН).

Alexandre de Rhodes (* 1591 Avignon; SJ; † 1660 Isfahan in Persia).

George de Rhodes (* 1597; SJ; † 1661).

Johannes Rhotert (Rhoters, * 1847; † 1925 Osnabrück?).

Tommaso Agostino Ricchini (* 1675 Cremona; OP (Dominican Friar); † 1762 Rome) became secretary of the Congregation of the Index and examiner of the bishops in 1749.

Michelangelo Ricci (* 1619 Rome; cardinal 1681; † 1682 Rome).

Jean (or Jeanne) Richard, might have been related to the French botanist Jean Michel Claude Richard (* 1787 Volon, Haute-Saône; † 1868) under whose direction many new species were introduced to Senegal. Might also have been related to Henri Richard (* 1880) who founded the Parisian Cafés Richard.

Owen Willans Richardson (* 1879; † 1959 Alton)

William Richardson surgeon Fellows of the Society of Antiquaries of Scotland (F.S.A. Sc.) practiced at Newton Street of central Birmingham in 1790.

Ulrich of Richenthal († abt. 1438).

Georg Wilhelm Richman (* 1711; † 1753)

Kurt R. Richter, professor emeritus at Graz University of Technology, Institute of Fundamentals and Theory in Electrical Engineering (Institut für Grundlagen und Theorie der Elektrotechnik - IGTE, Technische Universität Graz).

Mathias Rieberer (* 1730 Murau of Upper Styria; † 1794 Regensburg).

Alois Riedler (* 1850 Graz; † 1936).

Christian Rieger (* 1714 Vienna; † 1780 Vienna).

Johann Christoph Rieger (* c. 1696 Prussia; † 1774 The Hague), practical physician in Moscow.

Paul Joseph Riegger (* 1705 Freiburg im Breisgau; † 1775 Vienna).

Alois Adolf Riehl (Aloys, * 1844 Riehlhof by Bolzano (Bozen); † 1924 Neubabelsberg by Potsdam).

Nikolaus Riehl (* 1901 Saint Petersburg; † 1990 Munich).

Franz Xavier Riepl (Laurenz, * 1790 Vienna; † 1857 Graz).

Peter Theophil Riess (Gottlieb Rieß, * 1805 Berlin; † 1883), the academician in Berlin.

Anna Rigelnik (* 25 July 1858).

Augusto Righi (* 1850; † 1920).

Georges-Pierre-Édouard Rignoux, resided at Surgères in Charente-Inférieure 70 km east of city Charente in southwestern France in 1906-1908.

Sven Rinman (Rinmann, * 1720 Uppsala; † 1792 Eskilstuna).

Rinsō Aochi (青地林宗, * 1775; † 1833).

Martin Antoine del Rio (Delrio, * 17 May 1551, Antwerp; SJ 9 May 1580 Valladolid; † 19 October 1608 Leuven)

Gotō Rishun (後藤梨春, * 1696; † 1771).

Akisato Ritō (秋里籬島, worked 1780-1814).

Rudolf Ritschl (* 1902 Bonn; † 1982 Berlin)

Johann Wilhelm Ritter (* 1776 Zamienice in Silesian southwestern Poland; † 1810).

Auguste Arthur de la Rive (* 1801 Geneve; † 1873 Marseilles).

Lucien de la Rive (* 1834 Choulex; † 1924 Geneve)

Francesco Robba (* 1698; † 1757).

Nicolas Marie-Noel Robert (* 1761; † 1828).

Martyn John Roberts (* 1806 Wales; † 1878 Wales).

Robertson (Étienne-Gaspard Robert, * 1763 Liège; † 1837).

Joseph Clinton Robertson (pseudonym Sholto Percy, * c.1787; † 1852).

William Robertson (* 1721; † 1793).

Giles Person de Roberval (Personnier, * 1602; † 1675).

Karel Robida (baptized Lucas, * 1804 Mala Vas on banks of Sava river by Ježica now north part of Ljubljana; † 1877 Klagenfurt).

Denis M. Robinson (* 1907; † 1994).

Harold Roper Robinson FRS (* 1889 Ulverston in Lancashire south of Manchester in northern England; † 1955 London?).

John Robison (* 1733 Boggall at Glasgow; † 30 January 1805 Edinburgh).

John Wilmot Earl of Rochester (* 1647; † 1680),

Alan J. Rocke (* 1948 near Chicago, Illinois).

Johann Baptist Rogner (* 1823; † 1886).

Walter Rogowski (* 1881; † 1947).

Jacques Rohault (* 1620; † 1675).

Maximilian Eduard Rohm (* 30 January 1855 Neustadl (Náchod or Nové Město nad Metují) in Bohemia).

Theodor Rohm (* 1883; † 27 January 1953).

Theodor Rohm (* 1848/1849 Neustadl in Bohemia; † 10 January 1907 in Viennese 8th Bezirk Lenaugasse no. 2).

Wilhelm Julius Paul Rohn (* 1887 Dresden; † 1943).

Julius Bernhard von Rohr (* 1688; † 1742).

Heinrich Rohrer (* 1933 Buchs SG; † 2013 Wollerau).

Thomas Romich (Tomaž Romih, * December 8, 1853 Maria Dobje by Planina between Sevnica and Šentjur southeast of Celje; † 1935 Novo mesto).

Wilhelm Konrad Röntgen (Roentgen, * 1845; † 1923).

Michel Rosa (* 1731; † 1812).

Gustav Rose (* 1798 Berlin; † 1873 Berlin).

Karl Rosenberg (* 1861 Graz; † 1936 Graz) after 1913 titular full professor for Methodology of Physics at the University Graz.

Robert A. Rosenberg published about Edison in 1991-2015.

Ferdinand Rosenberger (* 1845 Lobeda by Jena; † 11. September 1899 Oberstdorf in Bayern).

Ignac count Rosenberger (Rosenberg, * 3 March 1724 Vienna as noble of Carinthia origin; SJ 2

November 1741 Trenčín; † 20 February 1801 Ljubljana).

Marshall Nicolas Rosenbluth (* 1927 Albany, New York; † 2003 San Diego, California).

Mitja Rosina (* 1935 Ljubljana).

Boris L'vovich Rosing (Борис Львович Розинг, * 1869 Petersburg; † 1933 Archangelsk).

Robert W. Rosner (* 1924 Vienna).

Andrew Ross (* 1956 lowlands of Scotland) emigrated to US in 1985.

Hugh Munro Ross (* 1870 Bexleyheath, Kent; † 1954 Eastbourne, East Sussex), Oxford classical graduate, editor of *The Times Engineering Supplement* as the journalist of *Times* from 1893 to 1946.

Ian Munro Ross (* 1927 Southport, UK; † 2013 New Smyrna Beach, Florida) ultimately served as the sixth President of Bell Labs 1979–1991.

Svein Rosseland (* 1894 Kvam in Vestland county, Norway; † 1984).

Francesco Rossetti (* 1833 Trento; † 1885 Padova).

Albert Salomon Anselm baron Rothschild (* October 29, 1844; † February 11, 1911).

Salomon Mayer von Rothschild (* 9 September 1774; † 28 July 1855).

count Henry Frances Rottenhan (* 1738; † 1809).

Henry Augustus Rowland (* 1848 Honesdale, Pennsylvania; † 1901).

Thomas D. Royds (* 1884 Lancashire; † 1955).

Abbé François Rozier (* 24 January 1734 Lyon; † 29 September 1793 Lyon).

Abbé Jean François Pilâtre de Rozier (* 1754; † 15 June 1785).

Franc Rozman (* 1941 Bled).

Anton Rožič (* 27 November 1791 Lower Tuštanj no, 12; † 23 March 1837 Lower (Spodnji) Tuštanj by Moravče in central Slovenia).

Viktor Ruard (* 1814 Stara Sava by Jesenice; † 1886 Stara Sava).

Paola Rubbi (* 1724; † 1749).

Alessandro Rossi da Lugo (Alexander Rubeus de Lugo, * 1607 Lugo by Ravenna; OFMconv 1624 Bologna; † 1686 Assisi?).

Antun von Rubido de Zagorje (Antal Zuchý, * 1817 Klanjec or Madrid; † 1863).

Sidonija Erdódy Rubido (* 1819 Zagreb; † 1888 Gornja Rijeka by Kalnik).

Woyciech Rubinowicz (Vojteh, Adalbert, * 1889; † 1974).

Antonio Rubio (Ruvius, * 1548 La Roda in Spain; SJ; † 1615 Alcalá) taught philosophy and theology in Mexico for a long time.

Reinhold Rüdénberg (Rudenberg, * 1883 Hanover; † 1961 Boston).

Karel Dragotin Rudež (* 1833 Ribnica; † 21 January 1885 Gracarjev Turn).

Waren de la Rue (* 1815; † 1889).

Alexis Baron Ruessenstein (flourished 1663-1694).

Konrad Baron Ruessenstein († August 12, 1668).

Ingolf Hermann Max Ruge (* 1934 Świdnica in Silesian south-western Poland (Schweidnitz).

Heinrich Daniel Ruhmkorff (* 1803; † 1877).

Benjamin Thomson count Rumford (* 1753 Woburn; † 1814 Paris).

Jakob Rumpf (* 1827 Graz).

Georg Eberhard Rumphius (George Rumpf, * 1627 Hessen; † 1702 Ambon Island as part of the Maluku Islands of Indonesia).

Lado Rupnik (* 1934).

Leon Rupnik (* 1880; † 1946).

Girolamo Ruscelli (* 1500 Viterbo; † 1566 Venice) published under his pseudonym Alessio Piemontese (Alexius Pedemontanus, * abt. 1471).

Ludwig Ruschitzka studied technic in Bohemian Ostrava and obtained his PhD at Faculty of Technical sciences of Freiberg Mining Academy (Bergakademie) in 1971 and 1988.

Ernst Ruska (* 1906 Heidelberg; † 1988 Berlin).

Helmut Ruska (* 1908 Heidelberg; † 1973 Düsseldorf)

Henry Norris Russell (* 1877; † 1957).

John Scott Russell (* 1808 Parkhead, Glasgow; † 1882 Ventnor, Isle of Wight).

Vinko Rutar (Venčeslav, * August 30, 1950 Modrej on the right bank of the Soča River north of Most na Soči, Municipality of Tolmin in the Littoral region of Slovenia), former Blinc's F5 collaborator with PhD in 1980. From 1986 to 1990 he headed the Nuclear Magnetic Resonance Imaging Laboratory at Iowa State University in Ames. He has been with Union Carbide since 1990 also as a senior researcher at the Bound Brook Technical Center in New Jersey until he turned Director of Quality at Absorption Systems LP at Greater Philadelphia Area.

Ernest Rutherford (* 1871; † 1937).

Walther Hermann Ryff (Gualtherus Hermenius Rivius, Ryf, Reif(f), Ru(e)ff, Rivius, parts published with pseudonyms connected to Tarquinius Schnellenberg, Tarquinius Ocyorus, Quintus Apollinari). * around 1500 perhaps in Strasbourg; † 1548 Würzburg).

Heiner Ryssel (* 1941 Plaue, Germany).

S

Loredana Sabaz (previously married Deranja, published 1989-2020).

general Sir Edward Sabine (* 1788 Dublin; † 1883 London).

Johannes de Sacrobosco (* c. 1195; † c. 1256).

Antoine-Isaac Silvestre de Sacy (* 1758 Paris; † 1838 Paris).

James Ballerum James Sadler (* 1753; † 1828).

Charles Sadron (* 1902 Cluis; † 1993 Orléans).

Henri de Saint Michel († 1793 Munich).

Chin-Tang Sah (萨支唐, * 1932 Beijing).

Megnad Sah (* 1893; † 1956).

Bernardino de Sahagún (born Bernardino de Rivera (Ribera, Ribeira), * c. 1499 Sahagún; OFM; † 1590).

Carl Reinhold Sahlberg (* 1779 Eura, Finland; † 1860 Yläne, Finland).

Johann Sahulka (Sakulka, * 1857 Deutsch-Wagram in Lower Austria; † 1927 Vienna).

Henry Étienne Sainte-Claire Deville (* 1818; † 1886).

Antoine count de Saint-Exupéry (* 1900; † 1944).

Fumikazu Saito (齋藤文一) professor of history of science at Pontificia Universidade Católica de São Paulo (PUC-SP, Pontifical Catholic University) in Brazil.

Tordas Kaloz Sajnovics (Sainiovics, * 1733 Tordas; † 1784 Pest).

Giovanni Generoso Salomoni printed-published in Rome in 1748-1786.

Peter Salcher (* 1848; † 1828).

Rudolf Saliger (* February 1, 1873, Spachendorf at Freudenthal in Silesia now Leskovec nad Moravicí (Špachov) in Czechian Moravia; † 31 January 1958 Vienna).

Albert Samassa (* 1808; † 1883).

Albert Samassa (* 1833; † 1917).

Maurizio Sangalli (* 1968 Lovere by Bergamo in Italy).

Bernard Sannig (Bernard ze Slezska, * 1637 Nysa in Polish Silesia; OFM 1655 Nysa; † 1704 Znojmo).

Joseph Sapetz (* Všechnovic in Moravia).

Sakuma Shōzan (佐久間象山, Zōzan, * 1811 Shinshu; † 1864).

Jacques Frédéric Saigey (* 1797 Montbéliard; † 1871 Paris).

Antonio Salieri (* 1750; † 1825).

lord Robert Cecil third Marquis Salisbury (* 1830; † 1903).

François-Étienne Dutour de Salvart (* 1711 Bailleul (Nord) ; † 1789 Riom in central France).

Maks Samec (* 10 October 1844 Arclin by Vojnik by Celje; † 19 August 1889 Šutna in Kamnik).

Maks Samec the younger (* 27 June 1881; † 1 June 1964).

Antonio-Nunes Ribeyra Sanchez (Ribeiro Sanches, * 1699 Penna-Macor; † 1783 Paris).

John Milton Sanders (* 1815 Cincinnati in Ohio; † 1880 Santo Domingo City in Caribbean).

Santorio Santorio (* 29 March 1561 Koper; † 22 February 1636 Venezia).

John C. Sarace (Carl, * New Jersey?), earned a BS from the University of Michigan.

Sarben Sarkar, Professor in Theoretical Physics at King's College London.

David Sarnoff (Давид Сарно́в, * 1891 Uzlyany by Minsk; † 1971 Manhattan).

Horace Bénédict de Saussure (* 1740; † 1799).

Nicolas Théodore de Saussure (* 1767; † 1845).

Félix Savart (* 1791; † Paris).

Alexandre Saverien (* 1720; † 1805).

Servington Savery (* 1669; † 1744 Shilstone in Devonshire).

Thomas Savery (* 1650 Shilstone in Devonshire; † 1715).

Pavle Savić (* 10 January 1908 Thessaloniki (Solun); † 1994).

William Edward Sawyer (* 1850 Brunswick in Cumberland County, Maine; † 1883 New York).

James Sayers (* 1912; † 1983).

Albert of Saxony (* c. 1320; † 1390).

Carlo Sbuelz (Karol Žbuelz, * 1844 Solkan by Gorizia).

Joseph Justus Scaliger (* 5 August 1540 Agen in France; † 21 January 1609 Leyden).

Bartolomeo Scappi (* 1500; † 1577).

Vincent Schaefer (* 1906 Schenectady; † 1993 Schenectady).

Johan Josef Franz Berthold Schaffgotsch (* 17 October 1741; † 1806).

Johan's half-brother Franz de Paula Ernst Schaffgotsch (* 27 December 1743 Horní Maršov; † 1809 Prague).

Jernej Schaller (Bartholomew, * 24 August 1745

Viennese suburb; SJ; † 29 April 1803 Ljubljana).

Carl Schapira (* 1879 Gdansk; † 1957 New York).

Morten Scharff (* 1926 Tibirke 60 kilometres north of Copenhagen; † 1961 Copenhagen).

Josef Schaschl (Šašel, Šašl, * 15 February 1860 Slovenji Plajberk (Windisch Bleiberg, Svinčnica); † 1908/1909).

Ludwig Schedius (* 20 December 1768, Raab (Győr); † 12 November 1847 Pest).

Karl Wilhelm Scheele (* 1742; † 1786).

Friedrich Wilhelm Joseph Schelling (* 1775; † 1854).

bishop of Bamberg Georg Schenk von Limpurg (* 1470; † 1522).

Karl Scherffer (* 1716 Gmünden; SJ 1732; † 1783 Vienna).

Paul Scherrer (* 1890; † 1969 Zurich).

Michael Brian Schiffer (* 1947 Winnipeg, Canada).

Jožef Anton Schiffner von Schiferstein (Šifrer, * 1677 Kranj; † 1756).

Karl Christoph Schneider (* 1778 Eisleben; † 23 1850 Kassel).

Anton E. Schindler (* 1921).

Wilhelm Schimitzek (* 1847 Silesia; † 1914 Vienna).

Ludwig Schiviz von Schivizhoffen (Ludovik Šivic, * 1859 Zagreb; † Ljubljana).

Arthur Schleede (* 1892 Berlin; † 1977), collaborator of Schröter in 1930s, from 1930 to 1935 associate professor of inorganic chemistry at the University of Leipzig, from 1935 to 1945 and from 1954 until retirement in 1957 taught inorganic chemistry at the Technical University of Berlin. Member of the NSDAP since 1933, signed the

German universities professors' confession to Adolf Hitler.

August Wilhelm Schlegel (* 1767 Hanover; † 1845 Bonn).

Wilhelm Schloemilch (*1870 Leipzig; † 1939 Schmöckwitz by Berlin).

Oscar Xaver Schlömilch (* 1823 Weimar; † 1901 Dresden).

Franz Schmelzer (* 27 June 1678 Vienna; SJ 9 October 1695 Vienna; † 26 January 1738 Vienna).
Anton Ritter von Schmerling (* 1805 Lichtental by Vienna; † 1893 Vienna).

Josef Camilo baron Schmidburg (* 1779 Graz; † 1846 Vienna).

Georg Gottlieb Schmidt (Luftschmidt, * 1768; † 1837 Giessen).

Gustav Johann Leopold Schmidt (* 1826 Vienna; † 1883 Prague) after studies at Viennese Polytechnic assisted F. Redtenbacher in Karlsruhe in 1856-1858 to become a docent for mechanical engineering (Maschinenbau) in Píbram hired on 2 August 1859, then transferred to Leoben and to then Russian Riga on 1 August 1862. After 1864 full professor of mechanical engineering at German Polytechnic in Prague.

Martin Johann Schmidt (Kremser Schmidt, * 25 September 1718 Grafenwörth of Lower Austria east of Krems on the way to Vienna; † 1801 Stein-sur-Danube).

Vlado Schmidt (Vladimir, * 1910 Prebold in Savinjska dolina; † 1996 Ljubljana).

Eugène II Schneider (* 1868 Le Creusot; † 1942 Paris).

Anselmus Schnell (Anselm, OSB; † 1751 Weingarten),

Tarquinius Schnellenberg (alias Tarquinius Syprum, alias Schnellenbergium, * ca. 1490 Attendorn/Westfalen, † 1561 Travemünde).

Johan Baptist Schober (* 1783 Oberweißbach; † 1850 castle Mühldorf, Feldkirchen a.d. Donau).

Josef Schober (* 1777 Ljubljana; † 1809 Vienna).

Friedrich Schoedler (* 1813 Dieburg in Hessen; † 1884 Mainz).

Benjamin Scholz (* 1786 Slezské Rudoltice (Rosswald) in Bohemian Silesia; † 1833).

Hans Schomburgk (* 1880; † 1967).

Michael Schön (* 1903 Weisbaden; † 1960 Munich).

Johann Philipp von Schönborn (* 1605; † 1673).
Johann Schöner (* 1477 Karlstadt am Main; † 1547 Nurnberg).

Arthur Moritz Schoenflies (* 17 April 1853 Landsberg (Gorzów) in western Poland; † 1928).

Janez Ludvik Schönleben (Johan, * 11 November 1618, Ljubljana; SJ 26 October 1635 Vienna–1654 Vienna; † 1681).

Adam Adolph Schöpfflein (* 1704; † 1753 Wurzburg?) military architect in Wurzburg.

Joop Schopman after many years at the University of Utrecht (Fakulteit der Wijsbegeerte, Rijksuniversiteit Utrecht) became a visiting professor at the University of Innsbruck, Austria in 1991 as well as at Boston College, USA to research the history and philosophy of science with artificial intelligence (AI) included.

Kaspar Schott (Gaspar, * 1608; † 1666).

Walter Schottky (* 1886; † 1976).

Gregor Schöttl (Gregorius Christianus Dominicus Schödtel, * 14 February 1732 Steyr; SJ 28 October 1739; † 4/5 November 1777 Ljubljana).

Janez Baptist Schöttl (Joannes Baptista Joannes Nepomucenus Sebastianus Schödl, * 23 June 1724 Steyr; SJ; † 1777), Gregor's older brother.

Ivan Schrabas (Hans Schrabass, Janez Schrawass), the vassal of the Counts of Celje mentioned from 30 September 1425 to 1441. Herman II granted him the feudal estates in Kostel, Krško, Trebanj and Ribnica parishes (ARS, SI_AS 1073/I-57r, folio 72'; StLA, HStAC Lordship and town of Cilli (Celje), box (Karton) 3, booklet (Heft) 15, Feudal Book for the Counties of Ortenburg and Celje 1436–1441 folios 47–48', 76; ARS, SI_AS 1063, reference number 4496, folio 3 (issued about the year 1440).

Johan Gottlieb Friedrich Schrader (* 1763 Salzdahlum by Wolfenbüttel; † 1832/1833 Sankt Petersburg?).

Heinrich Schramm (Hinko Schram, * 1837 Schönbrunn) began to teach at Rijeka Naval and Military Academy established on November 3, 1857. On 1 September 1860 he was promoted to full professorship. On 24 August 1863 Schramm and Sekulić became full professors at later Tesla's Real High School in Rakovac. In 1864 Schramm taught mathematics in High Real School in Wiener Neustadt. From 1868 to 1874 Schramm as a director there attracted one of his best students Rudolf Steiner. Schramm served as District School Inspector (Bezirks-Schulinspector) already in 1872 which became his profession serving the Viennese government in 1875-1886. Firstly, he was a Viennese based School Inspector (Schulinspector) for Lower Austrian real and trade school together with Joseph Krist in 1876 and later with Mathias Wretschko, serving the Ministry of Commerce (Handels Ministerium). Later he held the same job at Ministerium für Kultus und Unterricht (Ministry of Education and Worship) together with Adalbert knight Kunzek-Lichton (Izvešće Rakovac 1884, 22; Vuković, Valent, 2016, 92; *Hof- und Staat...*, Wien, 1876: 301, 309; 1878: 30, 318; 1881: 106, 124, 125; 1885: 84; 1886: 86; 1887: 88).

Johann Christian Daniel Schreiber (* 1739; † 1810).

Henrik Schreiner (* 1850 Ljutomer; † 1920 Maribor).

Ignatio Schreiner (* 1703 Vienna; SJ; † 1777 Vienna).

Johann Schreck (Terence, Terrentius, * 1576 Constance; SJ; † 1630 Beijing).

Wilhelm von Schröder (* 1640 Prešov in Slovakia; † 1688).

Erwin Schrödinger (* 1887; † 1961).

Karl Julius Schröer (* 1825 Bratislava; † 1900 Vienna).

Anton Schröter von Kristelli (* 1802; † 1875).

Fritz Georg Ernst Schröter (* 1886 Berlin; † 1973 Ulm).

Hugo Schrötter (Johann Karl, * 1856 Olomuc; † 1911 Graz).

Franc Schubert (* 1797; † 1828).

Helmut Schubert works at *Deutsches Museum* in Munich.

Johann Sigmund Schuckert (* 1846 Nuremberg; † 1895 Wiesbaden).

Hermann Schuler (Schüler, * 1894 Posen; † 1964 Göttingen).

Günter Victor Schulz (* 1905 Łódź; † 1999).

Johannes Schulz (* 1739).

Franz Leopold Schulz Edler von Strassnitzki (* 1835).

Friderik Schulz Edler von Strassnitzki.

Johann Nepomuk Paul Friedrich Schulz Edler von Strassnitzki (* 6 July 1831 Ljubljana).

Leopold Karl Schulz Edler von Strassnitzki (Straszinski, Strasznicki, Straßnitzki, * 31 March 1803 Krakow; † 9 June 1852 Bad Vöslau near Vienna).

Natalie baroness Grimbschitz married Schulz Edler von Strassnitzki (* 1845).

Sophia Selinger married Schulz Edler von Strassnitzki (Sofie Seeliger, Zeillinger, Zeilinger, Seliger).

Heinrich Christian Schumacher (* 1780 Bad Bramstedt in Holstein; † 1850 Altona in west Hamburg)

Winfried Otto Schumann (* 1888 Tübingen; † 1974 Munich).

Arthur Schuster (* 1851; † 1934).

George I. Schwartz published in 1958-1968.

Heinrich Schwarz (Karl Leonhard, * 1824 Eisleben in Prussia; † 1890 Eberswalde in Prussia).

August Schwarzer (Schwartz, * 1833) taught at first German Higher real school in Prague in 1859, and in Tabor 100 km south of Prague in 1871.

Silvan Samuel Schweber (Sam, * 1928 Strasbourg; † 2017 Lexington, Massachusetts) a French-born American theoretical physicist and science historian who was a professor at the newly founded Brandeis University from 1955.

Johannes Baptist Schwelmer (* 1728 Banská Bystrica; † 1775).

Daniel Schwenter (* 1585 Nuremberg; † 19 January 1636 Altdorf).

Julian Schwinger (* 1918; † 1994).

Anton Maria Schyrll (Rheita, * 1597/1604 Reutte in Tyrol; OFM Cap; † 14 November 1660).

Angelo Scocchi flourished 1900-1952 as a professor in Trieste.

Janez Anton Scopoli (Giuseppe Antonio, * 1723; † 1788).

John Duns Scotus (* about 1266 Duns; OFM; † 1308 Cologne (Köln)).

Michael Scotus (* 1175; † 1232).

Pietro Angelo Secchi (* 1818; SJ; † 1878).

Thomas Johann Seebeck (* 1770; † 1831).

Igor Segala works at Faculty of Mathematics and Physics, University of Ljubljana.

János András Segner (Johann Andreas Zegner, * 1704, Bratislava; † 1777).

Emilio Segré (Dino, * 1905 Rome; † 1989 California).

Marc Séguin (* 1786 Annonay; † 1875 Annonay).

Franz Sehr (* 1834 Frankstadt in Moravia).

Konrad Seidl (* 1830; † 1879).

Gotthard Seifert (* 1953 Grünhain, Saxony) worked at department of theoretical physics of University Paderborn (Theoretische Physik, Universität Paderborn) in 1998, later became a professor of theoretical chemistry (Theoretische Chemie) at TU Dresden.

Herbert Seifert (* 1945), received his PhD from the University of Vienna with a dissertation on Giovanni Buonaventura Viviani. He is now professor emeritus of musicology at Viennese university.

Frederick Seitz (* 1911 San Francisco; † 2008).

Martin Sekulić (Мартин Секулић, * 29 September 1833, Sankt Michael (Sv. Mihovil), today Lovinac in Lika; † 14 April 1905 Zagreb, buried at Roman Catholic part of Zagreb Mirogoj cemetery).

Martin's son general of artillery Rudolf von Sekulić (* 1860 Pest; † 10 October 1917 Bukovina).

Martin's son forester Vladko Sekulić (* 1865 Karlovac; † 1890 Karlovac).

Matija Seliger (* 21 January 1925 Vrhnika).

Janez Seliger (* 1949).

Nikolay Nikolaevich Semenov (* 1896; † 1986).

Andreas Semery (* 1630 Riems; SJ 1652 Rome; † 1717 Rome).

Marjorie Lee Senechal (née Wikler, * 1939 Saint Louis, Missouri).

Marjan Senegačnik (* 1928; † 2002).

Andrej Senekovič (* 1848; † 1926).

Daniel Sennert (* 1572 Wroclaw; † July 21, 1637).

Wolferd Senguerd (Wolfgang Senkward, Senguerolus, * 1646; † 1724).

Janko Serbec (* 1834; † 1909).

Thomæ Le Seur (Leseur, * 1703 Rethel; OM; † 1770 Rome).

Vitaly Dmitrievich Shafranov (Виталий Дмитриевич Шафранов, * 1929 small village Morvinovo 100 km east of Moscow; † 2014 Moscow).

Shao Kang (少康, his surname was Si 姒) sixth king of the Xia dynasty ruling ancient China in 2118-2097 B.C.

John Bennett Shank teaches history at University of Minnesota in Morris.

Trevor Royle Shaw (* 1928 UK) if Karst Research Institute in Postojna.

Edward Clarence Shepard (Shephard, † after 1862), English patent agent and inventor based on Duke Street Westminster-London in 1850s, later in 1861 based on Victoria street in Westminster, working on Floris Nollet's behalf in England and France.

Robert Sherwood Shankland (* 1908 Ohio; † 1982 Cleveland Ohio).

Osamu Shimomura (* 1928 Kyoto; † 2018, Nagasaki).

John Northrup Shive (* 1913 Baltimore; † 1984).

Shizuki Tadao (志 筑 忠雄, Chūhirō Nakano, Ryūho, * 1760 Nagasaki; † 1806).

William Bradford Shockley (* 1910; † 1989).

Franciszek Ksaver Shopfer (Schoepfer, * 1761; † 1808).

Dongfang Shuo (東方朔, * c. 160 BCE; † c. 93 BCE).

Thaddäus Siber (* 1774 Schrobenhausen in Bavaria; † 1854 Munich).

Ignatius Sichelbart (Ignaz Sickelbart, Sickelpart. 艾 啓蒙 / 艾 启蒙, Ài Qīměng, Ai Ch'i-meng, * 1708 Nejdeck (Neudeuk. Neudeck, Nedejk) in west Bohemian Sudetenland; SJ; † 1780 Beijing).

Willem Van Sichen (Guillaume, * 1632; OFM; † 1691 Leuven?).

Theodor Sidot (Théodore) preparator of chemical experiments at Lycée Charlemagne in Paris at least in 1866-1883.

Philipp Franz Balthazar von Siebold (* 1796 Wurzburg; † 1866 Munich).

Ernst Werner Siemens (* 1816; † 1892).

Wilhelm von Siemens (* 1855; † 1919).

sir William Siemens (Charles, * 1823; † 1883).

Alexander Siemens (* 1847 Hanover; † 1928).

Adolf Ferdinand Sieverts (* 1874).

Oskar Simony (* 1852 Vienna; † 1915 Vienna), Stefan's Viennese student in 1872, substitute teacher at the Viennese Academy of Commerce 1873, assistant professor of higher mathematics and theoretical mechanics at the Forestry School in Mariabrun in 1874, private assistant of mathematics at the University of Vienna in 1874, professor at the Bodencultur College in 1878, retired in 1913.

Peter Sigmund (* 1936 Karlsruhe).

Ruth Lewin Sime (* 2 July 1939 USA).

Saint Simon of Lipnica Murowana by Krakow in Silesia (Szimon a Lypnica, * abt. 1437; OFM; † 1482).

William Speirs Simpson (* 1845; † 1917) of the Simpson Lever Chain Co. He attended Glasgow University to become a Londoner specialist in metallurgy as inventor of armour-plating ships with fusion-welding.

baron Simon Georg Sina (* 1810; † 1876).

Liborio Siniscalchi (* 1674; † 1743).

Ida Mathilda Valeria Rosina Kanitz married Sirk (* 1852 Vienna).

Hugo Victor Carl Sirk (* 11 March 1881 Graz Heilige Blut; † 15 December 1959 Vienna).

Mathia Sirk (* 1809 Kamna gora east of Trebnje; † 1892 Graz).

Victor H. Sirk (* 1845).

Janez Siser (* 1 July 1608; † 1636).

Sigismund Siser (Siserius, Siserus, * 1 May 1636, Klagenfurt; SJ 7 October 1653, Leoben; † 29 December 1693 Vienna).

Sandi Sitar (* 1937 Ljubljana).

Franciscus Sitius (Sizzi, * Firenze; † 1618 Paris).

Hans Leo Sittauer (Johannes Sittauer, * 1911 Lhotě by Stříbro (Elhotten by Mies) in Bohemia; † 1998 Altenberg in Thüringen), also a poet.

Stanisław of Skarbimierz (Stanislaus de Scarbimiria, * 1360; † 1431).

Zdenko Hans Skraup (* 1850 Prague; † 1910 Vienna).

Adolf Carl Heinrich Slaby (* 1849 Berlin; † 1913 Charlottenburg).

Jurij Sladkonja (* 21 March 1456 Ljubljana; † 26 April 1522).

John Slater (* 1900; † 1976).

Joseph Slepian (* 1891 Boston; † 1969).

Josip Slišković (* 1901 Mostar; † 1984 Vienna).

Olexander Smakula (Олександр Теодорович Смакула, Александр Теодорович Смакула, * 1900 Dobrovody, Austria–Hungary, today Ukraine; † 1983 Auburn, Massachusetts, USA), Pohl's PhD student and assistant in Göttingen, after 1834 worked for Carl Zeiss AG in Jena.

John Smeaton (* 1724 Leeds; † 1794).

Adolf Gustav Stephan Smekal (* 1895; † 1959).

Franjo Smerdu (* 1905 Graz; † 1989).

Robert Smith (* 1689; † 1768).

Willoughby Smith (* 1828; † 1891).

Marian von Smolan Smoluchowski (* 1872; † 1917).

Louis Dijour Smullin (Lou, * 1916, Detroit, Michigan, United States; † 2009, Newton, Massachusetts, United States) of Radiation Laboratory at Massachusetts Institute of Technology.

Charles Percy baron Snow (of the City of Leicester, * 1905; † 1980).

Joannes de Monte Snyders (Snyder, * about 1625; † 1670).

king Jan III Sobieski (John, * 1629; † 1696).

Frederick Soddy (* 1877; † 1956).

Riemon Soga (* 1572; † 1636).

Alan David Sokal (* 1955 Boston, Massachusetts).

Franc Sokol (Sokoll, * 1779 Sadská in the Central Bohemian Region; † 1822 Ljubljana).

Velimir Sokol published on history of telegraph and telephone in 1964-1981.

Jury Ivanovič Solovjev (Yuri Ivanovich Solovyov, Юрий Ива́нович Соловьёв (* 1924 Krasnoyarsk (Красноярск) in Siberia).

Ernest Solvay (* 1838; † 1922).

Kelallur Nilakantha Somayaji (Keḷallur, Comatiri, * 1444; † 1544).

Edward Somerset, 2nd Marquess of Worcester (* 1602/1603; † 1667).

Arnold Sommerfeld (* 1868; † 1951).

baron Joseph Sonnenfels (* 1733; † 1817).

Étienne Souciet (* 1671; SJ; † 1744).

Robert John Soulen Junior (Bob, * 1940 Phoenixville, PA; † 2015), head of the Superconducting materials section at the Naval Research Laboratory in Washington DC.

Polycarpe de Souza (Sou Tche-Neng Joei-Kong, * 1697 Coimbra; SJ 1712 Portugal; † 1757 Peking).

Lazzaro Spallanzani (* 12 January 1729 Scandiano by Modena; † 11 February 1799 Pavia).

James M. Spangler (* 1848 Pennsylvania; † 1915 Chicago).

Morgan Sparks (* July 6, 1916 Pagosa Springs, Colorado; † May 3, 2008 Fullerton, California).

Johannes Sperlette (* 1661 Mouzon in Champagne; † 5 February 1725 Halle).

Marcus Johannes Sparnaay (* 1923 Amersfoort, Netherlands; † 2015).

Robert Spiller († abt. 1913 Maribor).

Franciscus Xavier Spindler (* 1726 Graz; † 1775 Graz).

Ignatz Spiro (* 1817; † 1894).

Lyman Spitzer (* 1919; † 1997).

Hermann Johann Philipp Sprengel (* 1834; † 1906).

Franz Seraph Stadium count Warthausen (* 1806; † June 8, 1856).

Ernst Karl Stadler von Wolfersgrün (Štodlárove z Wolfersgrýna, * 21 December 1871 Terezín (Theresienstadt) in northern Bohemia), acquired PhD in jurisprudence, married to Codelli in Ljubljana on 21 November 1897.

József Ferenz Staehling (Josef Franz Stähling, * 1743) physician in Bratislava.

George Ernst Stahl (* 1660 Jena; † 1734 Berlin).

Josef Staininger (Steininger, Staininger, * 1700 Vienna; SJ 1715; † 1766 Vienna).

William Edwards Staite (* 1809 Bristol; † 1854 Caen in France).

Petar Stambolić (* 1912; † 2007).

Pietro Stancovich (Petar Stanković, * 1771 Barban in Istria; † 1852 Barban).

William Stanley (* 1858 Brooklin; † 1916).

Valentin Stansel (Estancel, * 1621 Olomouc; † 18 December 1705 Salvador Bahia in Brazil).

Fabri Stapulensis (Jacques Lefevre, * 1450? Étaples in Picardy; † 1536).

Ante Starčević (* 1823 Veliki Žitnik near Gospić; † 1896).

Franz Xaver Stark von Rungberg (* 1840 Prague; † 1914).

Johannes Stark (* 1874; † 1957).

Olga Andreevna Staroseljskaja-Nikitina (Ol'ga Andreevna Starosel'skaja married Nikitina, Ольга Андреевна Старосельская-Никитина, * 1885 Kremenchuk (Kremenchug, Кременчук, Кременчук) in central Ukraine; † 1969).

John Wellington Starr (* 1821/22 Cincinnati, Ohio; † 1846 Birmingham, UK).

Katharina Startniek (Katherine, * 9 August 1822 Ferlach no. 56 vulgo Umniggin).

Simon Startinigg (* 11 January 1820 Rossenegg no. 2 in parish Ebenthal).

Joseph Startinik (* 1771; † 1848 Ferlach no 42).

Jean Servais Stas (* 1813; † 1891).

Giovanni Giacomo Staserio (* 1565; † 1635).

Albert Jan Staverman (* 1912 Bussum; † 1993).

Charles Henry Stearn (* 1844 Jamaica; † 1919).

Ernst Steckelmacher (* 1881 Mannheim; † 1943 Majdanek).

Walter Steckelmacher (* 1922 Mannheim; † 2006 Crawley in West Sussex).

Sir Richard Steele (* 1672 Dublin; † 1729 Wales).

Max Steenbeck (* 1904 Kiel; † 1985 East Berlin)

Aleš (Alexius) Stefan (* 16 July 1805 Lancova-Lanzendorf no. 5 Škocjan pri Podjuni (Sankt Kanzian am Klopeiner See in Jauntal); † 8 December 1872 Klagenfurt Stadt no. 370).

Jožef Stefan (Josef, * 1835; † 1893).

Maria widow of Adolf Neumann remarried Stefan (Maria Karoline, * 1839 Friesach in Carinthia?; † 2 September 1929 Vienna).

Karl-Heinz Steigerwald (* 1920 Koblenz; † 2001).

Franc Anton von Steinberg (Stemberg, * 1684 castle Kalec by Zagorje and Pivka in Karst; † 1765 Ljubljana)

Friedrich August Steiner (* 1840 Linz by Danube; † 1901 Prague), from 1878 the professor of engineering and graduated diploma engineer in German Polytechnic (*Technische Hochschule*) in Prague, published on photography and bridges in 1878-1909.

Jacob Steiner (* 1796; † 1863).

Rudolf Steiner (* 1861 Kraljevec (Königreich, Murakirály) in Međumurje part of north Croatia; † 1925 Dornach, Switzerland) reformer, architect, and clairvoyant as leader of spiritual research, esotericism, and theosophical movements.

Charles Proteus Steinmetz (Karl, * 1865 Breslau (today's Wrocław); † 1923).

Wolf Balthasar Adolf von Steinwehr (Steinwähr, * 1704 Dziedzice (Deetz) by Barlinek (Berlinchen) in Powiat Myśliborski (Powiat Soldau) of western Poland; † 1771 Frankfurt (Oder)).

Karl Stejskal (Karel) obtained PhD to become a professor of languages at Grammar Schools initially in Moravian Olomouc in 1870 and in Znaim (Znojmo) in 1880. In Bohemia and Vienna edited anthologies on statistics of Habsburgian High schools in 1870-1924.

Ivan Steklasa (* 1846; † 1921).

Heinrich von Stephan (* 1831; † 1897).

Mihael Stephan (* 29 September 1802 Lancova no 5 Škocjan pri Podjuni (Lanzendorf Sankt Kanzian am Klopeiner See in Jauntal)).

Richard Montgomery Stephenson (* 1917) taught at the College of Engineering of New York University.

Caspar Maria Sternberg (* 1761; † 1838).

Franz Josef Sternberg-Manderscheid (František Josef, count, *1763 Prague; † 1830 Prague).

Joachim Count Sternberg (* 1754/5, Prague; † 1808).

Robert Sterneck (* 1871; † 1928).

Walter Steubing (Friedrich Wilhelm, * 1885 Dillenburg; † 1965 Hamburg), Stark's graduate habilitation student in RWTH Aachen in 1908-1909.

Simon Stevin (* 1548; † 1620).

Balfour Stewart (* 1828; † 1887).

Andreas Josef baron Stifft (* 1760-Röschitz in Lower Austria; † 1836 Vienna).

Wolfgang Stiller (* 1940).

Anton Stimmelmayer (Stimmelmayr, * 1884 Dingolfing in Lower Bavaria; † 1963).

Jan Stobner (* 1360; † 1405).

George Gabriel Stokes (* 1819 County Sligo in Ireland; † 1903).

Joseph Stöcklein (* 1676; SJ; † 1733 Graz).
John Stone (* 1869 Virginia; † 1943 San Diego).

Georg Johnston Stoney (* 1826; † 1911).

Carl Störmer (* 1874; † 1957).

Jakob Strauss (* 1533 Ljubljana; † 28 June 1590 Celje).

Siegmund Strauß (Strauss, * 1875 Znojmo in Moravia; † 1942 New York), because of his Jewish origin emigrated from Vienna to London in 1938.

Franz Streinz (* 1855; † 1922).

Karl Edler von Stremayr (* 1823 Graz; † 1904).

Anton Strnad (Strnadt, * 1746; † 1799).

Janez Strnad (* 1934 Ljubljana; † 2015).

Aleš Strojnik (* 1921 Ljubljana; † 6 November 1995 Arizona).

Hinko Henry Stroke (* abt. 1928), Ph.D. Massachusetts Institute of Technology in 1955, professor of physics at New York University.

John Donovan Strong (* 1905 Lawrence, Kansas; † 1992 Amherst).

Vincenc Jurij Strupi (baron Vinko Struppi, Vincent Georg, * 1733 Trieste or Carniola proper; † 3 June 1810 Bürgerspitale no. 1166 in Vienna) Hofbaudirektor (court director of building) and Generalfeldwachtmeister (master general of field guards) and counsellor (Rath) at the Viennese Academy of visual arts (Akademie der bildenden Künste) in 1808 residing in Bürgerspitale no. 1166 (*Hof- und Staat...*, Wien, 1808: 4, 19, 59, 237, 705; Book of Funerals (Sterbebuch) St. Augustin in Vienna 03-04,5 page 65).

Ahacij Stržinar (* 1676; † 1741).

Charles II Stuart (* 1630; king; † 1685).

Herbert Arthur Stuart (* 1899; † 1974).
Johann Wilhelm Count Stubenberg (* 1619 Neustadt along the Mettau River in the east of the Bohemian Lands; † 24 April 1663 Kitzel in Hungary or 15 March 1663 Vienna).

Countess Marie Margarethe Stubenberg (* 1694 Graz; † 28 May 1724).

Andrej Studen (* Celje), professor of social history at the Philosophical Faculty of Ljubljana University.

Luca Stulli (Luka, * 1772; † 1828).

Bernard-Kilian Stumpf (* 1655 Wurzburg; † 1720 Beijing).

Carl Stumpf (* 1848; † 1936).

Johann Christoph Sturm (Sturmius, * 1635 Hilpoltstein (Mittelfranken); † 1703 Altdorf).

Peter Andrew Sturrock (* 1924 Stifford in Essex).

Johann Georg Stuver (Stubenrauch, * 1732 Oberliezheim in Swabia; † 1804 Vienna).

Georg Adolf Suckow (* 1751; † 1813).

Eduard Suess (* 1831; † 1914).

Anton Suhadolc (* 1935 Ljubljana), professor of mathematics at Ljubljana University.

Masatomo Sumitomo (住友政友, * 1585 Fakui north of Kyoto; † 1652), brother-in-law of Riemon Soga.

Tomomochi Sumitomo (Riemon, * 1607; † 1662), son of Riemon Soga and adopted son of Masatomo Sumitomo.

Kichizaemon VI Sumitomo Tomoito (住友吉左衛門, * 1865; † 1926).

Sey-Shing Sun, in 1989-2001 patented for at Planar Systems Inc., 1400 NW Compton Drive, Beaverton, OR 97006 formed in 1983 as a spinoff from Tektronix, in 2003-2006 for LSI Logic Corporation based in San Jose, California.

Richard T. Tuenge (* 1948) of Hillsboro, Oregon, in 1994-2012 at Planar Systems Inc., 1400 NW Compton Drive, Beaverton, Oregon 97006 1994

Ivan Supek (* 1915 Zagreb; † 2007 Zagreb).

Antonino Lo Surdo (* 1880 Syracuse; † 1949 Rome).

Charles Susskind (* 1921 Prague; † 2004 Berkeley), the Jewish professor emeritus of electrical engineering and a co-founder of bioengineering studies at the University of California.

Ivan Sušnik (* 1854 Škofja Loka; † 1942 Ljubljana).

William Sutherland (* 1859 Glasgow; † 1912 Melbourne)

Franc Svetic (Francišek Suetiz, * 1749 Kamnik).

Ivan Svetina (1851 Breznica in the municipality of Žirovnica-1936 Žirovnica).

Saša Svetina (* 1935 Celje).

Venczel Svoboda (Vaclav, Wenzl, Wenzel Swoboda), member of Bohemian Museum (böhmischen Museums) and Association for natural history in Bratislava (Vereins für Naturkunde in Preßburg), the director and professor of Greek and Latin languages like Tuschar at Bratislava (Gymnasiums zu Preßburg) from October 1853 until February 1861, also geography as director appointed on 25 February 1854. Later the Bohemian state school counsellor (Landes-Schul-Rath) in 1866 as director of Communal Real Ober Gymnasium in Deutsch-Brod by Kutteneberg (Havlíčkův Brod, until 1945 Německý Brod by Kutná Hora) where he still taught in 1884 (*Hof- und Staat...*, Wien, 1866: 380, 1874: 447, 455, 464; 1882: 348; 1884: 369)

Sonja Svoljšak, head curator of Manuscript, Rare and Old Prints Collection at NUK.

Elizabeth Swan married Mawson (1822 Penrith - 1905)

Joseph Wilson Swan (* 1828 Pallion in Sunderland; † 1914 Warlington).

Franz Seraphin Anton Swaty (* 1826 Bruck an der Leitha in Lower Austria; † 1888 Vienna).

Franz Xaver Alois Swaty (* 1855 Vienna; † 1907 Maribor).

Franziska Maria Wenedikter married Swaty, remarried Bayer (Fanny, * 1863; † 1941 Maribor).

Emanuel Swedenborg (Emmanuel Svedenborg, * 1688 Stockholm; † 1772 London).

Gerhard van Swieten (* 1700; † 1772).

Gottfried Baron van Swieten (* 29 October 1733 Leiden; † 29 March 1803 Vienna).

John Swift of BBC London was a journalist who under the pseudonym 'The Scanner' wrote news and gossip futuristic items in the TV edition of the Radio Times television diary in 1949.

Jonathan Swift (* 1667 Dublin; † 1745 Dublin).

John A. Campbell (* 1942) of Physics Department University of Canterbury, Christchurch, New Zealand.

Alban Archibald Campbell Swinton (* 1863; † 1930).

Jan Szczepanik (* 1872 Rudniki (Rudnyky, Рудники) in Habsburgian monarchy, now in Ukraine just on the other side of the border from Polish Przemyśl, † 1926 Tarnów in southeastern Poland (Lesser Poland)).

Ferenc Count Széchényi (* 1754 Fertőszéplak; † 1820 Vienna).

Angelika Szekely de Doba (Maria Josefa Székely, * 1891 Olomouc; † 1979 Graz).

Leo Szilard (* 1898; † 1964).

Kálmán von Nagy Szigeth Szily (Coloman Nagyszigeth, Nagy-Szigeth, * 1838 Izsák in central Hungary; † 1924 Budapest).

Š

Kristina Šamperl Purg (* 1950 Spuhlja east of Ptuj; † 2002 Ptuj).

Anton Šantel (* 1845; † 1920).

Josip Šašel (Wieser, * 1883 Windisch-Bleiberg; † 1961 Municipality of Prevalje).

Jakob Šašel (Schaschel, * 1832 Kappel (Kapla pri Borovljah) ; † 1902 Karlovac).

Jakob Šašel (* 13 April 1862 Karlovac; † 1911 Mahično suburb village by Karlovac).

Jožef Marija Šemerl (Schemerl, Schemmerl, * 1754; † 1844).

Marjeta Šentjunc (* 1940 Hrastnik).

Lidija Šentjunc (* 1911 Hrastnik; † 2000 Ljubljana).

Marija Šešić (Шешић, * 1952; † 2006 Beograd).

Тарас Григорович Шевченко (Ševčenko, Taras Hryhorovych Shevchenko, * 1814; † 1861).

Amalija Šimec (* 1893 Tržič; † 1960 Ljubljana).

Jan Šindel (Jan Ondřejův, Iohannes Andreae dictus Schindel, Joannes de Prague, * about 1370 Hradec Králové; † 1455/1457).

Lucijan Šinkovec (* 2 June 1914 Laze by Logatec; † 1966 Ethiopia).

Žiga Škerpin (* 1689 Kamnik; OFM 1703 Nazarje in Styria; † 1755 Ljubljana).

Jožef Škoda (* 1805; † 1881).

Ciril Šlebinger (Schlebinger, * 1907; † 2000).

Janko Šlebinger (* 1876; † 1951), director of NUK.

Vladimir Šlebinger (* 1906; † 1984).

Maja Ilich married Gombač, daughter of Iztok Ilich, granddaughter of Zorka Šlebinger.

Jože Šorn (* 1921 Ljubljana; † 1982).

Ivan Štrkljević (Johan Strkljević, Јохан Штркљевић, † 4 May 1896 Vinkovci).

Dragutin Ljudevit Šoštarić (* 1861 Rijeka; † 1890).

Sigismund Šoštarić von Letovanički (Šišman) director of Rakovac Real School from 1868.

Miran Špelič (* 1963 Ljubljana; OFM).

Franc Šturm (Sturm, * 1881 Donja Košana; † March 31, 1944).

Ivan Šubic (* 1856; † 1924).

Simon Šubic (Schubitz, Subić, Subič, * 28th of October 1830 Brodeh number 13 in Poljanska dolina near Škofja Loka (Brod bei Lack); † 27 July 1903 Graz).

Antun von Šufflay (Šufraj, * 1775 Samobor; † 1849).

Fran Šuklje (* 1849 Ljubljana; † 1935 castle Kamen in Kandija by Novo mesto).

Milan Šuklje (* 1881 Wiener Neustadt; † 1937 Golnik).

Rasto Švajgar (Schweiger, * 1919 Ribnica; † 2001 Nova Gorica).

T

Charles Symner Tainter (* 1854; † 1940 San Diego).

Peter Guthrie Tait (* 1831; † 1901 Edinburgh).

Takehara Shunchōsai (竹原春朝齊, † 1800).

Taqi al-Din Muhammad ibn Ma'ruf ash-Shami al-Asadi (الشمي معروف بن محمد الدين تقي), Takiyüddin, Taki, * 1526 Damascus; † 1585 Istanbul).

William Henry Fox Talbot (* 1800; † 1877).

Igor 'Evgenevich Tamm (* 1895; † 1971).

Joachim Tancke (Tancky, * 1557/1559 Perleberg in Brandenburg; † 1609 Leipzig).

Ching Wan Tang (鄧青雲, Dèng Qīngyún, * 1947 Hong Kong).

Laurentius Tapolcsányi (Lörinc, Vavrinec Tapolčáni, Topolčanský, * 1669 Ružindol (Rózsavölgy, Rosindol, Rosenthal) 10 km east of Trnava; SJ 1690 Vienna; † 1729 Trnava).

Boris Nikolaevič Tarasov (Nikolaevich, Борис Николаевич Тарасов, * 1947 Vladivostok (Владивосток)).

Lev Vasil'evich Tarasov (Лев Васильевич Тарасов, Тарасов, * 1934) graduated from the Moscow Engineering Physics Institute in 1958 with a degree in Theoretical Nuclear Physics. In 1989-1992 headed

the Department of the methodology of teaching the natural history and mathematical topics at the Moscow Institute for Advanced Studies of Educators. In 1992-1998 headed the Department of Physics at Moscow Open State Pedagogical University where he developed a new educational technology, ecology and dialectics as the scientific guidance of a pedagogical experiment on the practical implementation of technology.

Niccolo Fontana called Tartaglia (* 1499; † 1557).

Peter Tartareti of Romont (Tatareti, Pierre Tartaret, * c. 1460 Romont in Canton de Fribourg in the diocese of Lausanne in Switzerland; † (1494)/1522 Paris).

Girolamo Tartarotti (Hieronymous, * 1706 Rovereto by Trento (Trent); † 1761).

Giuseppe Tartini (* 1692 Piran; † 26 February 1770 Padua).

Tarvisini (Giacomo Placentini, * 1672; † 1762).

Alessandro Tassoni (* 1565 Modena; † 1635).

Innocent baron Taufferer (Inocenc, * 1 January 1722 Turn by Višnja Gora (castle); SJ 28 October 1738 Vienna; † 14 January 1794 Ljubljana).

Jurij Jožef Dizma Taufferer (Franc Ksaver, * 22 March 1733 Turn by Višnja Gora; † 1789 Ljubljana).

Eduard Taussig, in 1889-1893 worked as a metallurgist at Bahrenfeld in Holstein, now the western quarter of Hamburg. Related to Prague based Jewish family Taussig.

Štefan Tausig (Taussig) the first director of Central Technical Library in Ljubljana (CTK) in 1950–1951, the first director of Ljubljana Trubar's Antiquarian Bookshop up to his retirement in 1969.

Janko Tavzes (* 1893 Idrija; † 1959 Ljubljana).

Brooke Taylor (* 18 August 1685 Edmonton Middlesex; † 29 December 1731 house Somerset in London).

Geoffrey Ingram Taylor (* 1886 London; † 1975 Cambridge).

Richard Taylor (* 1781; † 1858).

Gordon Kidd Teal (* 1907 Dallas; † 2003 Dallas).

Frederik II of Teck a son of Hermann I von Teck (* 1260; † 1314).

Frederik IV Duke of Teck's father Frederik III of Teck (Frederick, Friedrich, * 1325; † 28 September 1390).

Frederik IV Duke of Teck (Frederick, Friedrich, † 4 August 1411).

Frederik IV Duke of Teck's sister Margaret Teck in 1397 married countess Ortenburg († 1422).

Frederik III of Teck's father Ludwig III von Teck († 28 January 1334).

Margaret's brother Ulrich duke of Teck († 7 August 1432).

Albrecht Wenzel von Tegetthoff (* 1841 Graz; † July 22, 1871).

vice-admiral Wilhelm von Tegetthoff (* December 23, 1827 Maribor; † 7 April 1871).

Hermann Friedrich Teichmeyer (* 1685; † 1746).

Themistius (Themis, Themistus, Themistius, * 317 Paphlagonia in central Anatolia; † 388 Constantinople).

Richard H. Templer, Department of Chemistry, Imperial College, London.

Louis Jacques Tenar (* 1777; † 1857).

Reshef Tenne (* 1944 kibbutz Usha in the western Galilee), Department of Materials and Interfaces, Weizmann Institute, Rehovot, Israel.

Wilhelm Ernst Tentzel (* 1659 Greußen an der Helbe; † 1707 Dresden).

Robert Kyle Grenville Temple (* 1945 USA).

Grigory Nikolaevich Teplov (Григорий Николаевич Теплов, * 1717; † 1779).

Filip Terpin (Trpin, * 1603/1604 Selca above Škofja Loka; † 23 June 1683 Šmartno by Cerklje by Kranj (pri Kranju)).

Blaž Terpinč (Terpinz, * 1759 Bled; † 1836 Kranj).

Fidelis Terpinč (* 1799; † 1875).

Milutin Tesla (* 1819 Raduč; † 1879 Gospić).

Nikola Tesla (* 1856; † 1943).

Gilles Thébault (* 1703; † 1766).

Richard Theile (* 1913 Halle (Saale); † 1974 Amrum) researched image recording tubes with photosensitive semiconductor layers at the laboratory for physical research at Telefunken, headed by Fritz Schröter. Under Theile's leadership iconoscope-type image tubes were developed in addition to photomultipliers.

Jean Thibaud (* 1901; † 1960).

Nicolas Thillaye (* 1709 near Lizieux; † 1784 Rouen).

Noël-Vincent Thillaye (Nicolas, * 1749 Rouen; † 1802 Val de la Haie).

Jacques-François-René Thillaye (* 1750; † 1791), a botanist.

Jean-Baptiste-Jacques Thillaye (* 1752; † 1822), a physician anatomist-surgeon.

Hans Thirring (* 1888; † 1976).

Henrik Evald Tholander (Thålander, * 1847 Stockholm; † 1910 Stockholm).

Johann Thölde of Hesse (* 1565; † 1624).

Thomas of York (OFM; † 1268/69).

Émile Thomas (* 2 April 1907 Brussels; † 14 January 2001).

Peter Jørgen Julius Thomsen (* 1826; † 1909).

Elihu Thomson (* 1853; † 1937).

George Paget Thomson (* 1892; † 1975).

Joseph John Thomson (* 1856; † 1940).

Lynn Thorndike (* 1856 Lynn, Massachusetts, USA; † 1940 New York City).

Richard Threlfall (* 1861; † 1932).

John S. Thurman, invented vacuum cleaners in St. Louis, Missouri in 1898 and 1899. His descendant John S. Thurman (* 1908 St. Louis, Missouri) also worked for General Compressed Air Company, New York.

Jean-François Tremblay was a Hong Kong business reporter-contractor from October 1995 until September 2019; then he became a Public Relations Specialist of Huawei at Shenzhen, Guangdong, China.

count Johann Tserclaes Tilly (* 1559; † 1632).

Arkadij Klimentovič Timirjazez (Аркадий Климентович Тимирязев, * 1880; † 1955), the son of K.A. Timirjazez. Arkadij studied physics with P. N. Lebedev. In 1909–1911 Privat-docent, since 1918 professor at Moscow University, in 1919–1930 professor of the Communist University named by Y. M. Sverdlov.

Kliment Arkadyevich Timiryazev (Тимирязев, Климент Аркадьевич Тимирязев, * 1843; † 1920), a Darwinist, corresponding member of the Russian Academy of Sciences since 1871, professor at the Petrovsky Agricultural and Forestry Academy, from 1878–1911 at Moscow University. Married to Alexandra Alekseevna Timiryazev (Тимирязев, Александра Алексеевна Тимирязева, born Loveyko (Ловейко), first married Gottwalt (Готвальт), * 1857; † 1943).

Gaston Tissandier (* 1843; † 1899).

Miha Tišler (* 1926 Ljubljana).

Franz Titelmann (Titelman, * 1498 Hasselt in the district of Liège; OFM cap; † 1537),

Giuseppe Toaldo (* 1719; † 1797).

Richard C. Tolman (* 1881; † 1948 Pasadena).

Eduard baron Tomaschek (Emanuel, * 1810 Matzen in Lower Austria; † 11 December 1890 Vienna).

Adam Tomcsányi (* 1755; † 1831).

Aleksandar S. Tomić, NanoLab, Faculty of Mechanical Engineering, University of Belgrade.

Petar Tomić (* 1839 Zabok in Zagorje; † 1918).

Sin-Itiro Tomonaga (* 1906; † 1979).

Lewi Tonks (* 1897; † 1971).

August Töpler (Toepler, * 1836; † 1912).

Josip Torbar (* 1824; † 1900).

Gisela Torkar works at *Deutsches Museum* in Munich.

Giovanni Maria della Torre (* 1713; † 1782).

Ludwig II della Torre (* 1338; † 1365).

Evangelista Torricelli (* 1608; † 1647).

Maurizio Torrini (* 1942 Firenze; † 2019 Firenze).

Stephen Toulmin (* 1922 London; † 2009 Los Angeles).

Richard Towneley (* 1629; † 1707).

John Sealey Edward Townsend (* 1868 Galway; † 1957).

Arnold Joseph Toynbee (* 1889; † 1975).

Antonio Targioni Tozzetti (* 1785; † 1856).

Muzio Giuseppe Spirito knight de Tommasini (Mutius von Tommasini, * 1794 Trieste; † 1879).

Luca Tozzi (* 1638 Frignano; † 1717 Napoli).

Antonio Trampus (* 1967 Trieste).

Johann Thomas Trattner (* 1717 Jormansforf in Burgerland; † 1798).

Nikola Trbojevich (Trbojević, * May 21, 1886 Petrovoselo in Lika; † December 2, 1973 Los Angeles).

Sam Bard Treiman (* 1925 Chicago; † 1999 New York).

Henri Édouard Tresca (* 1814 Dunkirk; † 1885 Paris).

Franc Tricarico (* 1719; † 1788).

Fortunato de Tridento (* Val di Sole; † 1674).

Franz von Paul Triesnecker (Drissenecker, * 1745; † 1817).

Philippe du Trieu (Phillipe Triev, * 14 November 1580 Havré in the province of Hainaut in Wallonia region of Belgium; SJ 27 May 1603 Tournai; † 25 August 1645 Douai in northern France).

Nicolas Trigaut (* 1577; SJ; † 1628).

George Lockwood Trigg (* 1925; † 2014 Pennington, New Jersey), editor of *Physical Review Letters (PRL)* from 1958 through 1988, published on quantum mechanics and modern physics in 1964-2005 connected to Brookhaven National Laboratory, Upton, N.Y.

Johann Georg Trigler von Iglerau (Triegler von Iglerau, fl. 1613-1622) the magister of philosophy as well as astronomer, captain (Hauptmann) as a sort of military engineer of the castle and manor Goldenstein (Branná, former Kolštejn) in Bohemian Sudetenland. The former Ljubljana based protestant Hieronymus Megiser has dedicated to his friend Trigler fifth of the volumes of Megiser's translations

from French and Italian languages into German language entitled *Theatri Machinarum* as the addition to the first three volumes of Heinrich Zeising's *Theatri Machinarum*.

Jurij Andrej Triller Count Trilek (* 1663; † 1701).

Johann Bartholomäus Trommsdorf (* 1770 Erfurt; † 1837).

Louis Joseph Troost (* 1825 Paris; † 1911).

Primož Trubar (* 1508; † 1586).

Clifford Ambrose Truesdell III (* 1919 Los Angeles; † 2000 Baltimore).

Donald Trump (* 1946 New York).

John George Trump (* 1907 New York; † 1985 Cambridge, Massachusetts).

Melania Knaus married Trump (Melanija, * 1970 Novo Mesto-Sevnica).

Lu Tsan-ning's (* 919; † 1001 AD).

Gustav Tschermak Edler von Seysenegg (* 1836; † 1927).

Raphael Tsu (* 1931 Shanghai).

James Leslie Tuck (* 1910 Manchester; † 1980).

Ana Konkordia Elisabeth Turjaška (Auersperg, * 1610; † 1636).

count Ditrih Turjaški (Dietrich Teodorik Auersperg, * 1578; † 1634).

count Janez Andrej Turjaški (Auersperg, * 1615; † 1664).

Heinrich Turjaški (Auersperg, * 1721 Graz; † 1793 Graz).

Herbert VIII Turjaški (Auersperg, * 1528; † 1575).

count Herbert Turjaški (Herward Auersperg, * 1613; † 1678).

19th count Herbert Turjaški (Auersperg, * 1733; † 1801).

Prince Janez Franc Ferdinand Turjaški (Auersperg, * 1655; † 1706).

Janez Vajkard Turjaški (prince Johann Weikhard Auersperg, * 11 March 1615 castle Žužemberk; † 13 November 1677 Ljubljana).

baron Krištof Turjaški (Auersperg, * 27 October 1550 Turjak; † 14 May 1592 Ljubljana).

count Volk Engelbert Turjaški (Wolf Auersperg, * 1610; † 1673).

Volker Turjaški (Volkhard, Volklein Auersperg, * 1401; † 1451/1454).

Edward Turner (* 1798; † 1837).

Gregor Tuschar (Tušar, * 6 March 1816 Idrija; † 12 November 1891, Gorizia), classical philologist retired as Gorizia High School professor.

Nasir al-Din Tusi (al-Din al-Tusu, Nasradin Hođa, * 1201 Tus in Iran; † 1274 Baghdad).

Ivan Tušek (* 1835; † 1877).

Richard Quintin Twiss (* 1920 Simla in Northern India; † 2005).

John Tyndall (* 1820; † 1893).

U

Franz Übelacker (baptized Johann Georg Uebelacker, Abbé Georg after 1782, Ubelacker, * 1742 Meersburg, Baden-Württemberg; OSB in abbey Petershausen of north Konstanz by German border with Switzerland in 1761–1782; † after 1800 Vienna or Graz).

Udagawa Shinsai (宇田川 榛齋, * 1769; † 1832).

Udagawa Yōan (宇田川 榕菴, * 1798; † 1846).

Eduard Uhl (* 1813; † 1892).

Anton de Ulloa (* 1716 Sevilla; † 1795 Isla de León).

Robert David Ulrich received his PhD under the supervision of Fraser Pierpont Price at University of Massachusetts Amherst in August 1972, in 1978 worked at Noryl Products Department of General Electric Plastics Division, Selkirk, New York, USA.

Ulugh Beg (* 1393; † 1449).

baron Ivan Ungnad (Johann, * 1493; † 27 December 1564 Vintířov).

Leopold Baron Unterberger (* 1734; † 1818).

Francis Robbins Upton (* 1852 Peabody; † 1921 Orange New Jersey).

Kurt Urban (* 1904; † 1928).

Alfred knight Urbanitzky (* 1852 Voitsberg 30 km west of Graz in Styria; † 1905 Vienna).

Jožef Urbanizi (OFM; † 16 March 1708 Novo Mesto).

Anton Urbas (* 13 September 1822 Idrija; † 22 September 1899 Ljubljana).

Milena Uršič (* 1901 Ljubljana; † 1990 Ljubljana).

Viktor Aleksandrovich Urvalov (Виктор Александрович Урвалов, * 1928 Leningrad (Ленинград)), in 1980 became a head of the historical section of the VNTORES in Leningrad (now RNTORES, Russian Scientific and Technical Society of Radio Engineering, Electronics and Communications) named after A.S. Popov in St. Petersburg (Исторической секции ВНТОРЭС - Ленинград, now РНТОРЭС - Российское научно-техническое общество радиотехники, электроники и связи имени А. С. Попова в Санкт-Петербурге).

Nikolai Dmitriyevich Ustinov (Nikolaï Dmitrievich, Николай Дмитриевич Устинов, * 1931 Moscow; † 1992 Moscow), son of the leading Soviet politician

Marshal of the Soviet Union Dmitriy Fyodorovich Ustinov (ДМИТРИЙ ФЁДОРОВИЧ УСТИНОВ, * 1908 Samara (Самара) in southeastern Russia; † 1984 Moscow).

Gaetano Gaspar Uttini (* 1741; † 1817).

V

Anton Vakselj (* 1899; † 1987).

Marko Vakselj (* 1932; † 2017).

Eduard Valenta (* 1857; † 1937).

Matija Valjavec (Kračmánov, * 1831 Srednja Bela by Preddvor; † 1897 Zagreb).

Count Janez Ambrož Thurn-Valsassina (* 1553; † 1625).

His grandnephew Count Janez Ambrož Thurn-Valsassina († 1654).

count Janez Krstnik Thurn-Hoffer and Valsassina (* 1699; † 1783).

Josef Thurn-Hoffer and Valsassina (Hofer, * 1681; † 1775).

(baron) Janez Vajkard Valvasor (* 1641; † 1693).

Carl Clinton Van Doren (* 1885 Hope, Illinois; † 1950 Torrington, Connecticut).

Alois Vaniček (* 1825 Prague; † 1883 Prague) professor of classical philology at German Grammar School (Gymnasium) in Olomouc (Olmütz).

Giovanni Francesco Vanni (* 1638 Lucca; SJ; † 1709 Rome).

Anton Vanossi (Antal Vanossy, Antonio Vánossi, * 1683 Raab (Győr); SJ 1703 Graz; † 1757 Rome).

Aimé Varcin (* 1630; † 1702).

Johann-Franz Varrentrapp (* 1706; † 1786).

Pierre Varignon (* 1654 Caen; SJ; † 23 December 1722 Paris).

Cromwell Fleetwood Varley (* 1828; † 1883).

Jan II Kazimierz Vasa (Jean-Casimir Waza, * 1609, king 1648-1668; † 1672).

Ladislaus IV Vasa (Władysław IV Waza, * 1595; king 1632; † 1648).

Abraham Vater (* 1684 Wittenberg; † 1751 Wittenberg).

Christian Vater (* 1651; † 1732).

Sergej Ivanovič Vavilov (Sergey Ivanovich Wawilow, Сергѣй Ива́нович Вави́лов, * 1891 Moscow; † 1951 Moscow).

Natalja Vasiljevna Vdovičenko (Наталія Васильевна Вдовиченко, Natalija Vasilivna Vdovichenko, Vdovychenko, Natalija Vasylivna Vdovychenko, * 1940 Soviet Union).

France Veber (* 1890 Gornja Radgona; † 1975 Ljubljana).

Vanna Vedaldi Iasbez (Jazbec, * 1943), professor of Roman administrative history at the University of Trieste since 1991.

Inca mestizo Prince Garcilaso de la Vega (Gómez Suárez de Figueroa, El Inca, El Inka, Ynca, * 1539 Cusco; † 1616 Cordoba).

Jurij baron Vega (* 1754; † 1802).

Lars Vegard (* 1880; † 1963 Oslo).

Vladimir Veksler (Володимир Йосипович Векслер, * 1907 Zhytomyr in western Ukraine; † 1966 Moscow).

Joannis Velikanović (Ivan, * 1723 Slavonski Brod, 1723; † 1803 Vukovar).

Helena Klara Velikonja (* 1936; † 1991).

Narte Velikonja (* 1891; † 1945).

Josip Velko (Welko, * 1825; † 1896).

Jean-Mathieu Tournu de Ventavon (Wang Dahong, Matou, 汪達洪, * 1733; † 1787).

Pier Paolo Vergerio the Elder (* 23 July 1370 Koper; † 1444/45).

Hubert Germain Verhaeren (* 1877 Zundert, The Netherlands; Congregatio Missionis CM), returned to Beijing in 1920.

Auguste Victor Louis Verneuil (* 1856 Dunkirk; † 1913).

Pietro Verri (* 1728; † 1797).

Evert Johannes Willem Verweij (Verwey, * 1905 Amsterdam; † 1981 Utrecht).

Alenka Vesel, president of DVTS elected in 2020.

Nicolò Vidacovich (Vida-Covi, * 1875 Trieste; † 1934).

Ivan Vidav (* 1918; † 2015).

Luka Vidmar (* 1977).

Milan Vidmar (* 1885 Ljubljana; † 1962 Ljubljana).

Artur Viegas (* 1868 Mata (Torres Novas), Portugal; SJ 1882 Barro in Portugal; † 1929 La Guardia (Pontevedra) in Spain).

Augusto Vierthaler (* 1838 Vienna; † 1901 Trieste).

François Viète (Viète, * 1540; † 1603).

Gotthold Richard Vieweg (* 1896 Topfseifersdorf; † 1972 Kälberbronn).

Josip Vilfan (* August 30, 1878 Trieste; † March 8, 1955 Belgrade).

Aleksander Vilhar (* 16 February 1814 Mountain (Planina) no. 74 by Rakek; † 1868).

Dušan Vilhar (* 1867; † 1913).

Miroslav Vilhar (Wilicher, * 1818, Upper Mountain (Planina) no. 74; † 1871).

Wilhelm Vilhar (Vilim, * 12 February 1840 Planina no. 74).

Arnoldi de Villa Nova (Arnaldus Villanova, * around 1235 near Valencia; † 1311 at sea between Naples and Genoa).

Paul Ulrich Villard (* 1860; † 1934).

Charles Marie Joseph Hennequin de Villermont, count de Villermont (Carlos, * 1864 area of Couvin in southeast Belgium; † 1929), mayor of Boussu-en-Fagne 4 km north of Couvin in southeast Belgium in 1900-1921.

Ioannes Vincentius (Jean Vincent, * ca. 1606; around 1625 joined the Doctrinaires (Prêtres séculiers de la doctrine chrétienne Secular Priests of Christian Doctrine a French religious order founded in 1592 by Cesar de Bus); † ca. 1673/1677) taught philosophy and became rector of the college at Toulouse, later also a provincial. Used to be a Thomist and critic of Cartesians.

Leonardo da Vinci (* 1452; † 1519).

Mykolas Kaributas Visniaveckis (Wisniowecki, * 1649; king from 1669; † 1673).

Mutio Vitelleschi (Muzio, Mutius Vitelesco, * 1563 Rome; † 1645 Rome).

Joseph Vitanović (* 1843 Tenja in eastern Slavonia southeast of Osijek).

Marcus Vitruvius Pollio (* about 75/80 B.C.; † about 15/25 A.D.)

Swami Vivekananda (born Narendranath Datta, * 1863; † 1902), an Indic Hindu monk.

Vincenzo Viviani (* 1622; † 1703).

Anatolij Nikolaevič Vjalcev (Vâl'cev, Vjal'cev, Анатолий Николаевич Вяльцев) worked at the Institute of history of sciences and techniques of the

Academy of Science of Soviet Union (сотрудник Института истории естествознания и техники Академии наук СССР).

Andrej Erofeevič Vjatkin (Андрей Ерофеевич Вяткин, * 1903; † 1970).

Giampaolo Vlacovich (* 23 October 1825 Vis (Lissa) ; † 11 January 1899 Padua).

Nikola Vlahovic (Vlahovich, Nicolaus Vlahović, Niccolò Vlacovich, * 1832 Brač or Vis (Lissa); † 1890 Trieste).

Anatoly Alexandrovich Vlasov (Анатоль Александрович Власов, * 1908 Balashov; † 1975 Moscow).

Henri Vleminckx printed in Brussels in 1749-1772.

Hugo Vodnik (baptized Simon, * 1715; OFM; † 1785).

Valentin Vodnik (* 1758 Zgornja Šiška by Ljubljana; OFM; † 1819 Ljubljana).

Peter Vodopivec (* 1946 Beograd), interested in technological aspects of Slovenian history.

Willi Voege (Willy, * 1877; † 1957 Hamburg) worked at Physikalische Staatslaboratorium in Hamburg in Germany.

Samuel Gottlieb Vogel (* 1750; † 1837).

Gottfried Voigt (* 1644 Delitzsch in Saxony; † 1682 Hamburg).

Johann Heinrich Voigt (Johan, * 27 June 1751 Gotha; † 6 September 1823 Jena).

Burchard de Volder (* 1643 Amsterdam; † 1709).

Charles Volet (* 1895 Vevey in Switzerland; † 1992).

Carl Gottfried Wilhelm Vollmer (Pseudonyms W. F. A. Zimmermann by his wife's maiden name, W. C. A. Zimmermann, C. Morvell, * 1797/98 Torún

(Thorn) in north central Poland; † 1864 Stuttgart or Berlin).

Alessandro Volta (* 1745; † 1827).

Gennadij Stepanovič Voronov (Gennady, Gennadii Stepanovich, Геннадий Степанович Воронов) is a leading researcher at the Institute of General Physics named by A.M. Prokhorov inside RAS (Russian Academy of Sciences), in Department of Plasma Physics, Laboratory of physics and diagnostics of hot plasma together with Elena Vladimirovna Voronova (Елена Владимировна Воронова).

Antonio Vorster (Anton Forster, Antoine Vorstler, * 12 September 1706 Vienna; SJ 27 December 1721 Vienna; † abt. 1773 Graz?).

Georg Vortmann (Giorgio, * 1854 Treste; † 1932 Barcola (Barkovlje)).

Sergej Vošnjak (* 1924 Ptuj; † 2005 Ljubljana).

Bernard Vovk (* 1824 Brezovica in parish Ovsiše; OFM; † 1911 Brežice).

William Hugh Pembroke Vowles (* 1885 Pembroke; † 1951).

Života Vranič (Žika, * 1934 Mojsinje by Čačak; † 1958 Paris).

Ivan Vrhovec (Verhovec, * 1853 Spodnje Poljane by Ljubljana; † 1902 Ljubljana).

Živko Vukasović (* 1829; † 1874).

Ivica Vuković, senior lecturer at Zagreb University of Applied Sciences.

Stanislas Vydra (Wydra, * 1741; † 1804).

W

Johannes Diderik van der Waals (* 1837; † 1923).

Friedrich Wächter, researched in Vienna in 1880-1914.

Ram Sarup Wadhwa (Пам Саруп Вадхва) physicist from India who studied solid state physics with Nikolai Borissowitsch Brandt (Николай Борисович Брандт, * 1923 Moscow; † 2015 Moscow) in Moscow and married the physicist Natalia Vladimirovna Deineko (Наталья Владимировна Дэйнеко).

Jan Wagenaar (* 1709; † 1773).

Karl Willy Wagner (* 1881 Friedrichsdorf 20 km north of Frankfurt; † 1953 Friedrichsdorf).

Kurt Wagner obtained his PhD at Institut für Gesellschaftswissenschaften, Berlin with a thesis about Walter Gerlach in 1969.

Vincenz August Wagner (* 1790 Thannhausen; † 1833 Guttenbrunn).

Jacob Tripler Wainwright (* 1854).

Robert K. Waits (Bob, * abt. 1935) worked at Fairchild Exploratory Devices section of the physics department and the thin films section technology for fabricating high value resistors in 1960s. in 2001-2020 he resided at Sunnyvale West, California.

Johann Ernst Emmanuel Walch (* 1725; † 1778).

Johann Georg Walch (* 1693 Meiningen; † 1775 Jena).

Joseph Walcher (* 6 January 1718 Linz; SJ 18 October 1737; † 29 November 1803 Vienna).

Beno Waldreich (Valterč, * Tyrol; OFMobs before 1705; † 30 March 1754 Novo Mesto).

Frederic Barnes Waldron († 1973) began as a workshop trainee in a Sheffield sheet metal factory, ending his career as a specialist in glass manufacture. In 1944/45 he worked for Pilkington Brothers Limited in Liverpool, England, and in 1949 he resided at Eccleston Park of Prescot, England. The prize with his name is awarded via the Institution of Mechanical Engineers (IMEchE) in London.

Sir Nicholas Peter Rathbone Wall (* 1945; † 2017).

William Wallace (* 1825 Manchester; † 1904).

William Augustine Wallace (* 1918 New York; OP (Dominican friar); † 2015 Washington, DC).

Otto Wallach (* 1847; † 1931).

Ignaz Gustav Wallentin (* 1852 Vienna; † 1934 Baden in Lower Austria).

Johan Gottschalk Walley (Wallerius, * 1709; † 1785).

John Wallis (* 1616; † 1703).

Wolfgang Wallner studied at Graz University of Technology to work there in alumni affairs staff unit since 2008.

Hartmut Walravens (* 1944 Adorf in Diemelsee (Waldeck-Frankenberg)).

Adalbert Carl Ritter von Waltenhofen zu Eglöfsheimb (Karl, * May 14, 1828 castle Admontbichl west of Graz in Styria, † 5 February 1914 Vienna).

Ernest Thomas Sinton Walton (* 1903 Abbeyside in Ireland; † 1995 Belfast).

Janez Wanggo (Joannes, * 25 September 1724 Neoforensis (Neumarkt) between Graz and Murau east of Graz in Styria; SJ 15 October 1745 Vienna; † 1799 Graz).

Felix Wankel (* 1902 Lahr; † 1988 Heidelberg).

James Alfred Wanklyn (* 1834; † 1906). = James Alfred Wanklyn (* 1834 Ashton-under-Lyne by Manchester; † 1906 New Malden suburb of south-west London).

Emil Gabriel Warburg (* 1846; † 1931).

Edward Wight Washburn (* 1881 Beatrice, Nebraska; † 1934).

Franz Xaver August von Wasserberg (Franciscus Xaverius de, * 1748 Vienna; † 1791 Vienna), a Viennese translator of many chemical books.

Anton Wassmuth (* 1844; † 1927).

Benjamin Waterhouse (* 1754; † 1846).

Francis Watkins (* 1800; † 1847).

James Watson (* 1928).

Richard Watson (* 1737; † 1816).

William Watson (* 1715 London; † 1787 London).

James Watt (* 1736; † 1819).

Robert Alexander Watson-Watt (* 1892; † 1873).

John Thomas Way (* 1820; † 1883).

Harold Worthington Webb (* 1884; † 1974).

Heinrich Friedrich Weber (* 1843; † 1912).

Johann Adam Weber (* 1611; Augustinian; † 1695).

Wilhelm Eduard Weber (* 1804; † 1891).

Johann Jacob Wecker (* 1528 Basel; † 1586).

Albin Wedam (* 1921; † 1997).

Edgar Wedekind (* 1870 Altona by Hamburg; † 1938 Erfurt).

Josiah Wedgwood (* 12 July 1730 Burslem in Staffordshire, England; † 3 January 1795 Etruria in Staffordshire).

Lienhard Wegmann (* 1918 Amriswil (Thurgau Canton) in Switzerland; † 1986 Triibbach (Wartau, St. Gall Canton)) after his PhD at Zurich University in 1947 developed the electron microscopy for the firm Trüb, Täuber & Co. AG. In 1965 he became a head of development of the division of corpuscular beam devices unit department at Balzers AG focused on the construction of the photoemission electron microscope named Metioscope.

Arthur Wehnelt (* 1871 Rio de Janeiro; † 1944 Berlin).

Gottfried Karl Wehner (Fred, * 1910 Bärenwalde 100 km southeast of Dresden; † 1996 Gauting 20 km southeast of Munich).

Wei Boyang (Wei Po Yang, 魏伯陽, Yunyazi, * Shangyu District, Shaoxing, China) flourished in 121-142.

Ku Wei-ying (古偉瀛) is a professor at the History department of National Taiwan University (Taipei), specializing in 19th and 20th century Chinese history.

Kastul Weibl's (Castul Waibl, Caztallus Waibl, baptized as Janez, * 28 April 1741 Novo mesto, 1756/57 OFM Novo mesto; † 25 October 1805).

Johann Fridericus Weidler (* 1691 Großneuhausen in Thuringia; † 1755 Wittenberg).

Hermann Klaus Hugo Weyl (* 1885 Elmshorn; † 1955 Zurich) theorist of number and physics as well as Husserl's follower in philosophy.

Jean Lazare Weiller (* 1858 Sélestat in Alsace; † 1928 Territet in Switzerland).

Steven Weinberg (* 1933 New York City) son of Jewish immigrants, Nobel Prize winner in physics in 1989.

Ignatz Weiner (Ignaz, * 1831) professor of geometry and architecture at the Communal Lower (later Higher) Real school in Brno in 1860-1882.

Franz Karl von Weinhardt (Weikhard, Weykard, Weykhard, * 1703; † 12 June 1768 Ljubljana).

Adolf Ferdinand Weinhold (* 1841; † 1917).

Ludwig Julius Weisbach (* 1806; † 1871).

Gerhard Wiesenfeldt (* 1966 Germany).

Christian Samuel Weiss (* 1780 Leipzig; † 1856 Cheb in Bohemia).

Edmund Weiss (* 1837; † 1917).

Ida Franziska Weiß (Weiss, * 1925 Bleiburg (Pliberg); † 2009 Klagenfurt).

Albin Weissbach (* 1833; † 1901).

Karl baron Weizsäcker (* 1912; † 2007).

Stephen P. Weldon from Texas, professor at the History of sciences department at University of Oklahoma as the editor of *ISIS' Current Bibliography of History of Science*.

Jean Joseph Welter (* 1763; † 1852).

Georg Wendt received his PhD with research on spectrum of mercury at Tübingen University in 1911, published about electrotechnics in 1912-1956, finally researched for the firm based at the castle (Château) de Corbeville by Orsay at Central France 25 km southeast of Paris.

Wilhelm Wertheim (* 1815; † 1861).

Franz Xavier Wessely (Veselý, * 1819 Rajnocovice 33 kilometres north-east of Kroměříž in Bohemia; † 1904 Kroměříž).

George Westinghouse (* 1846; † 1914).

Karl Josef Westritschnig (* 1947 Althofen (Stari Dvor) by Grafenstein (Grabštajn) in Carinthia).

Karl Avguštin Weykard (* 24 August 1736 Ljubljana).

Andrew Wezyk nicknamed Serpens (* 1377; † 1430).

Bruce R. Wheaton (* July 7, 1944) professor emeritus at Berkeley.

Charles Wheatstone (* 1802; † 1875).

William Whewell (* 1794; † 1866).

John Whitehead (* 1854 Trieste; † 1902 Rijeka).

Willis R. Whitney (* 1868; † 1958).

Rolf Widerøe (Widerøe, * 1902 Oslo; † 1996).

Bohuslav Ritter von Widmann (* 1836 Olomouc; † 1911).

Alois Beckh-Widmanstätten (Aloys Joseph Franz Xaver Beckh Edler von Widmanstetten, * 1754, Graz; † 1849, Vienna).

Johann Emil Wiechert (* 1861; † 1928).

Gustav Heinrich's son Eilhard Wiedemann (Ernst Gustav, * 1852 Berlin; † 1928 Erlangen).

Gustav Heinrich Wiedemann (* 1826; † 1899).

Wilhelm Anton Friedrich Wieghorst headed the firm Wilhelm Anton Friedrich Wieghorst and Company in Hamburg in 1868-1884, also the firm Wieghorst and son.

Wilhelm Wien (Willy, * 1864 Gaffken near Fischhausen (Primorsk, Приморск) in East Prussia now Russia; † 1928 Munich).

Julius Ritter von Wiesner (* 1838 Čechyně (Tschechen) in Moravia; † 1916 Vienna).

Franz Wiesthaler (* 1825; † 1890).

Eugene Wigner (* 1902 Budapest; † 1995 Princeton).

Martin Johann Wikosch (* 1754 Uherský Brod (Ungarisch Brod) in Moravia; † 1826 Vienna).

Johan Carl Wilcke (* 1732 Wismar; † 1796 Stockholm).

Emil Wilde (* 1793; † 1859).

Franz Xaver Wilde (Franc Ksaver, * 1753 Karłowice Wielkie in Polish Silesia; † 1828 Vienna).

Kajetan Wildenstein (Josef August, * 1703 Styria; † January 6, 1764 Ljubljana).

Dr. Eduard Wildhagen (Pseudonym Hans Killian, * 1890 Fallersleben; † 1970 Hamburg), Berliner editor-publisher, also issued the chess books.

Maurice Hugh Frederick Wilkins (* 15 December 1916; † 2004).

Clyde E. Williams (* 1903 Salt Lake City; † 1988 Ohio?) the president of Battelle's Memorial Institute in Columbus, Ohio from 1934, until he formed his own company named Clyde Williams and Company in Columbus, Ohio in 1958.

Evan James Williams (* 1903 Carmarthenshire in Wales; † 1945).

Ian Wills works at the University of Sydney, Unit for History and Philosophy of Science.

Christophous Wilpenhoffer (Vilpenhoffer, Bilpenhoffer, * 1597; SJ 1614; † 1671).

Alan Herries Wilson (sir, * 1906 Wallasey, Cheshire.; † 1995).

Benjamin Wilson (* 1721 Leeds; † 1788).

Charles Thomson Rees Wilson (* 1869; † 1959).

David B. Wilson (* 1941), professor at Iowa State University.

Harold Albert Wilson (* 1874 York; † 1964 Houston).

James Wilson (* c.1665; † 1730 London).

John Wilson († 1746), gained his M.A. at the University of Edinburgh.

Patrick Wilson (* 1743; † 1811), assistant to his father the professor of practical astronomy in the Glasgow University Alexander Wilson (* 1714; † 1786) in 1782.

Thomas Woodrow Wilson (* 1856; † 1924).

Adolf August Winkelmann (Adolph, * 1848 Dorsten in Westfalen; † 1910 Jena).

Clemens Winkler (* 1838; † 1904).

Johann Heinrich Winkler (Winckler, * 1703 Wingendorf near Lauban; † 1770 Leipzig).

Otto Ch. Winkler (* 1910 Stuttgart; † 1996) worked during three decades for Balzers in Liechtenstein after the establishment of that firm in 1946.

Eduard Winter (* 1896 Hrádek nad Nisou (Grottau, Gródek nad Nysą; † 1982 East Berlin) in Bohemian Sudetenland; † 1982 Berlin), the Catholic priest supporting the Jesuits in 1919-1940, then Nazi professor of history in Prague, and after 1945 Marxist.

Karl Winter, the Viennese electrician, in 1847-1849 experimented with electrophorus locally referred by his name.

Maria Wirgler (* 1879; † 1874).

Erazmus Ciołek Witelo (Witelon, Vitellio, Vitello, Vitello Thuringopolonis, Vitulon, Erazm Ciołek, * 1230 Legnica in Silesia; † 1280/1314).

Ferdinand Maria Wittelsbach (* 31 October 1636; † 26 May 1679) ruler of Bavaria.

Bavarian Prince elector Maximilian I of the house of Wittelsbach (* 17 April 1573; † 27 September 1651)

Duke of Bavaria-Leuchtenberg Maximilian Philipp Hieronymus of the house of Wittelsbach (* 1638; † 1705).

Ferdinand Wittenbauer (* 18 February 1857; † 1922 Graz).

Ludwig Wittgenstein (* 1889 Vienna; † 1951 Cambridge).

Paweł Włodkowic (Paulus Vladimiri, * ca. 1370; † October 9, 1435).

Josef W. Wohinz (Bohinc, * 1943 Knittelfeld between Judenburg and Leoben in Styria).

Jan Nepomuk Woldrich (* 1834; † 1906 Prague).

Maximilian Wolf (Max, * 1863 Heidelberg; † 1932 Heidelberg) the pioneer of astrophotography.

Nataniel Mateusz Wolf (Nathanael Matthäus von Wolf, Wolfe, * 1724 Chojnice; † 1784 Gdansk).

Christian Wolff (* 24 January 1679 Breslau; † 9 April 1754).

Jacob Wolff de Pforzheim (Jacobus von Pfortzen, * Pforzheim (Pfortzen) between Stuttgart and Karlsruhe; † 1519 Basel).

William Hyde Wollaston (* 1766 Dereham, United Kingdom; † 1828 Chislehurst, United Kingdom).

Arthur E. Woodruff (Kim, * August 18, 1928 New Haven, Conn.; † September 11, 2004 San Francisco), published on history of science in 1954-1968.

Peter Woulfe (* 1727; † 1803).

Pierre Wouters (* 1702; † 1792).

Andrej Wretschko (Vrečko, * November 14, 1846 Planina (Montpreis) castle 10 km northwest of Sevnica and 10 km south of Šentjur by Celje in Styria owned and renovated by dr. Jožef Gorišek from 1830 until 1851). Vrečko studied at the grammar school and at the University of Vienna, where in 1870 he passed the proficiency test for mathematics and physics while he was J. Stefan's assistant at the Institute of Physics. He was briefly a substitute teacher in Vienna in 1871, then teacher at real school in Maribor and from 1873 a professor at a German grammar school in Brno. From 1885 he worked in Celje, where he was appointed inspector two years later.

dr. Mathias Wretschko (Matija, * 23 February 1834 Jurklošter or 10 km northwest Sveti Lenart nad Laškim (Sankt Leonhard by Tüffer, now Vrh and Laškim) in Lower Styria; † 18 November 1918 Eichgraben 30 km west of Vienna 1919), the botanist, taught mathematics-physics at Ljubljana Grammar school in 1861-1865, member of Viennese zoological-botanical society, school inspector for Inner Austrian mathematics-Natural History courses

at the Viennese Ministry of Commerce (Handels Ministerium) in 1869-1893, knighted in 1883.

Arthur Williams Wright (* 1836; † 1915).

Joseph Wright of Derby (* 1734; † 1797).

Szymunt Florenty Wroblewski (* 1845; † 1888).

Adolph Wüllner (* 1835 Düsseldorf; † 1908 Aachen).

Gundaker Count Wurmbrand (Ladislaus Gundaccar Gregor Alois von Wurmbrand-Stuppach, * 1838 Vienna; † 1901 Graz).

Michael Werner (* 30 December 1829 Ljubljana; † 31 January 1891 Feldhof by Graz).

Y

Pavel Nikolayevich Yablochkov (Jabločkov, Jablochhoff, Павел Николаевич Яблочков, * 1847; † 1894).

Charles B. Yarling (* abt. 1950 USA) left Varian Ion Implant Systems to join Process Product Corporation for the rapid thermal processing in 1991.

Natan Aronovich Yavlinsky (Javlinsky, Yavlinskii, Натан Аронович Явлинский, * 1912 Kharkov; † 1962).

Julius Conrad Count Yelin (* 1771; † 1826).

Trygve Dewey Yensen (* 1884; † 1950 Pittsburgh).

Thomas Young (1773; † 1829).

St. Francis Xavier (* 1506; † 1552).

Yu Xi (虞喜, courtesy name Zhongning (仲寧), born in Shaoxing at Zhejiang province, fl. 307-345), a Han Chinese astronomer.

Adolph-Andrei Pavlovich Yushkevich (Adolf Pavlovič Jushkevich, Адольф-Андрей Павлович Юшкевич, * 1906 Odessa; † 1993 Moscow).

Z

Giacomo Zabarella (* 5 September 1533 Padova; † 25 October 1589 Padova).

Augusto Zacco (Augusto Antonio M. Zacchi, * 10 November 1662 Padua; † 18 February 1739 Treviso).

Franz Xaver baron Zach (* 1754 Pest, Hungary; † 1832 Paris, France).

Aleksander Zahlbrucker (* 1860; † May 8, 1938).

Karl Zahlbrucker (* 1858 Bratislava; † 7 November 1931 Maribor).

Albert Francis Zahm (* 1862 New Lexington, Ohio; † 1954).

Joannes Zahn (* 1633 Karlstadt; monk Premonstratensians (The Order of Canons Regular of Prémontré); † 1707).

Neža Zajc (* 1979).

Anton Zalar (* 1943; † 2006).

Stanislaw Zalenski (* 1843; SJ 5 November 1857 Baumgartenberg; † 1908).

Bojan Zaletel (* 1920 Postojna; † 1981 Kranjska Gora).

Franz Seraphim Zallinger zum Thurn (Francisco Zallinger ad Turrim, Seraphin, Seraph Zeilinger, * 14 February 1743 Bolzano; SJ 9 October 1760 Upper German Province; † 2 October 1828 Innsbruck) published as Tyrolean professor on mathematics, mechanics, Tyrolean floods and electricity of Tyrolean tourmaline in 1772-1808.

Franz's brother Jakob Anton von Zallinger zum Thurn (* 26 July 1735 Oberbozen (Bolzano) in South Tyrol; SJ 9 December 1753; † 11/16 January 1813 Bozen (Botzen, Bolzano)) published on theology, Newtonianism and Kantianism in 1773-1799.

Franz's brother Joannes Baptist Zallinger zum Thurn (Joann Batista, Giovanni Battista, * August 16, 1731 Bolzano; SJ 9 October 1747 Upper German Province?; † 11 July 1785 Bolzano), published on botany-agriculture as the Jesuitical and ex-Jesuitical professor in 1766-1780.

Marko Zalokar (* July 14, 1918 Ljubljana; † September 4, 2012 Seattle, WA.).

Count Francesco Zambecari (* 1752 Bologna; † 1812 Bologna).

Giuseppe Zamboni (* 1776; † 1846).

Brne Zamagna (Brno Zamanja, Bernard Džamanjić, * 1735 Dubrovnik; SJ; † 1820 Dubrovnik).

Ludwik Lejzer Zamenhof (Ludwik Łazarz Zamenhof, * 1859; † 1917).

Josip von Zanchi (* 23 August 1710 Rijeka, † 1786 Gorizia).

Gian Girolamo Zannichelli (Joanne Hieronymo, * 1662; † 1729).

Francesco Maria Zanotti (* 1692; † 1777).

Francesco Zantedeschi (* 1797; † 1873).

Pieter Zeeman (* 1865 Zonnemaire on the island of Schowen; † 1943).

Miroslav Zei (* 1914 Nabrežina (Aurisina) by Trieste; † 2006).

Josef Zeilinger (Zeillinger, * 1815).

Theresa married Zeilinger (Zeillinger, * 1824).

Heinrich Zeising (Zeisingk, Zeisenck, † 1610 or a little earlier).

Carl Friedrich Zeiss (* 1816; † 1888).

Vladimir Vasiljevič Zheleznyakov (Zheleznyakov, * 1931 Nizhny Novgorod).

Raffaella Zelli (Rafael Zell, * 20 August 1772 Jacobuzzi in Italy; = Raffaella Zelli (Rafael Zell Jacobuzzi, Jacobuzi, Jacobacio, * 20 August 1772 Viterbo 70 km north of Rome;

Bernard Zendrini (Bernardo, * 1679 Savioire by Brescia; † 1747 Venezia).

Jonathan Zenneck (* 1871; † 1959).

Ferdinand von Zeppelin (* 1839; † 1917).

Andrej Zergol (Tergol, Cergol, Zergoll, * 8 September 1595 St. Križ by Vipava (Heilegenkreuz); SJ 8 September 1614; † 23 January 1645 Millstatt by Celovec).

Franz Zergoll von Zergollern (* 1613; † 4 May 1657 Ljubljana).

Philipp von Zesen (Filip Caesio, * 1619; † 1689).

Lazarus Zetzner (* 1551; † 1616 Strasbourg).

Gustav Zeuner (* 1828; † 1907).

Avrelij Zevko (Čeuko, Zheuko, Frans Aurelium Zhenkho, OFM; † 1746 Ljubljana).

Zheng He (鄭和, * 1371; † 1433/35).

Jakob Ziegler (* 1470/71 Landau; † August 1549 Passau).

Baccio Ziliotto (* 1880 Trieste; † 1961).

Marc-Antonio Zimara (Marc Anton, * about 1460 S. Pietro in the Galati (Lecce); † 1532 Padua).

Burkard Zink (* 1396 Memmingen; † 1474 Augsburg).

Johannes Zink (Zengg, * Memmingen; † 1415).

Gilbert J. Zinsmeister (* 1929 (1930) Triesen, Liechtenstein) worked for Balzers Vaduz, Liechtenstein.

Teofil Zinsmeister (Franc, Theophilus, * November 2, 1777 Bavaria; OFMobs October 10, 1796; Entered

Carniolan province in 1803; † November 12, 1817 Novo Mesto (Franciscans of Ljubljana's diary, 1658/1660-1828, folio 159)).

Károly Zipernowsky (* 1853 Vienna; † 1942 Budapest).

Vinko Zlatić (* 1974).

Georgius de Zobel (* abt. 1737 Vienna) studied philosophy in Graz in 1754-1755 as a resident of the imperial convict Ferdiandeum in Graz, probably the younger brother of Joannes Georgius de Zobel who obtained his PhD in philosophy in the Viennese Jesuitical class of Franciscus Ginhör (Gindhör, * 1714) in June 1752.

Johann (Ivan Branimir) Zoch (Иван Бранислав Зох, Čika Apik, * 1843 Jasenová in north Slovakia; † 1921 Modra in eastern Slovakia).

Karel Zois (Karl, * 1756; † 1799 Trieste).

Žiga Zois (Sigismund, * 23 January 1747 Trieste; † 10 November 1819 Ljubljana).

Alfred Zöllner (Zoeller, † Bavaria?) researched in Charlottenburg by Berlin in 1913-1924. On 1 September 1945 the master mechanic Alfred Zoller founded the Zoller company as a mechanical workshop in Ludwigsburg 12 kilometers north of Stuttgart city center, now headed by Eberhard Zöllner (Zoller, * 1 September 1941 Stuttgart?) as a firm for measuring, inspecting and managing cutting tools named E. Zoller GmbH & Co. KG Einstell- und Messgeräte in Pleidelsheim by Stuttgart. Related to the son of Bavarian immigrants in the USA Robert Alfred Zoeller (* 1869 Tarboro, Edgecombe County, NC; † 1954).

Johann Karl Friedrich Zöllner (* 1834; † 1882).

Ivana Zorić, curator of the Nikola Tesla museum in Belgrade

John Vitéz de Zredna (Zrednai Vitéz János, Ivan Vitez od Sredne, * c. 1408 Sredna by Križevci; † 8 August 1472).

Juraj Zrinski (* 12 April 1549 Čakovec; † 4 May 1603).

Count Petar Zrinski (* 1621; † 1671)

Nicoló Zucchi (* 1586; SJ; † 1670).

Mark Zuckerberg (* 1984).

Diego de Zúñiga of Salamanca (Didacus a Stunica, * 1536 Salamanca; Augustinian Hermit; † 1597/1598 Toledo).

Črt Zupančič (Črtomir, * 1928 Ljubljana; † 2018 Munich), the Ljubljana Classical Grammar School classmate of the father of author of this book.

Ivan Zupančič (* 1930 Ljubljana; † 1999 Ljubljana).

Janez Anton Suppanschitsch (Zupančič, * 1785 Ljubljana; † 1833 Koper).

Zvonka Zupanič Slavec (* 1958 Maribor).

Eduard Otto Zwietusch (Edie, * 1866 Milwaukee; † 1931 Berlin).

Otto Zwietusch (* 1832 Germany).

Theodor Zwinger the Elder (* 2 August 1533 Basel; † 10 March 1588 Basel).

Fran Zwitter (* 1905 Bela Cerkev in Carniola; † 1988 Ljubljana).

Vladimir Kosmič Zworykin (Владимир Козьмич Зворыкин, * 1889 Murom (Муром) southeast of Moscow; † 1982 Princeton).

Ž

Anton Žabkar (Tone, * 1949 Ljubljana; † 1997 Trzin by Ljubljana) whose father was from Raka by Krško.

Avgust Žáček (* 1886; † 1961).

Jan Žižka z Trocnova a Kalicha (Johann Ziska, John Zizka of Trocnov and the Chalice, * c. 1360; † 1424).

Jože Žontar (* 1932 Kranj) the archivist-historian, son of the historian Josip Žontar (* 1895 Jesenice; † 1982 Kranj).

Darko Žubrinić (* 1956 Zagreb), full professor at Department of Applied Mathematics on Faculty of Electrical Engineering and Computing in Zagreb.

Mirjana Žumer married Pregelj.

Slobodan Žumer (Daša, * 1945), Mirjana's brother.

Lea Županc Mežnar worked at Inštitut za tehnologijo površin in optoelektroniko, Teslova 30, Ljubljana, later Kolektor at Pro d.o.o., Vojkova 10, Idrija.

Andraž Marjan Žvab (* 1980 Kranj; † 2020).

37.8 Index of Frequently Mentioned Places

Alexandria in Egypt
Amsterdam
Athens
Baghdad
Beijing (Peking)
Beograd (Belgrade)
Budapest
Cairo
Canton (Guangzhou, 广州)
Cape Town in South Africa
Celje (Cilli)
Cerknica
Chicago
Copenhagen
Cuba
Črnomelj
Damascus in Syria
Dejima (Deshima, 出島)
Fara in Kostel
Frankfurt
Glasgow
Gorizia (Gorica)
Graz
Innsbruck
Istanbul (Constantinople)
Jerusalem
Kerala in India
Kiev
Kočevje
Koper
Krakow
Kranj
Liechtenstein
Ljubljana
London
Los Angeles
Lvov (Lviv, Lemberg)
Madrid
Manchester
Maribor
Marseille
Metlika
Milano

Moscow
Munich

Nagasaki
New York
Novo Mesto
Osaka
Paris
Petersburg (Sankt Petersburg, Leningrad)
Piran
Pittsburgh
Postojna
Prague
Ptuj (Petovia)
Ribnica
Rijeka
Rio de Janeiro
Roma (Roma)
San Francisco
Sarajevo
Shanghai
Sodevci
Srobotnik
Stockholm
Syracuse in Sicily
Teheran
Togo in Africa
Tokyo (Edo)
Trieste
Varaždin
Venice
Vienna
Warsaw (Warszawa)
Washington
Zagreb
Žužemberk