

See discussions, stats, and author profiles for this publication at: <https://www.researchgate.net/publication/316432467>

Implementation of PI Controller for Boost Converter in PV System

Article · December 2016

CITATIONS

35

READS

14,336

7 authors, including:



Nagarajan Ramalingam

Gnanamani College of Technology

147 PUBLICATIONS 1,141 CITATIONS

[SEE PROFILE](#)



Sivasree Sathishkumar

routes

17 PUBLICATIONS 578 CITATIONS

[SEE PROFILE](#)

Some of the authors of this publication are also working on these related projects:



POWER FECTRONICS [View project](#)



One-Step Microwave Synthesis of Pure and Mn Doped WO₃ Nanoparticles and Its Structural, Optical and Electrochemical Properties [View project](#)

Implementation of PI Controller for Boost Converter in PV System

R.Nagarajan¹, J.Chandramohan², S.Sathishkumar³,
S.Anantharaj⁴, G.Jayakumar⁵, M.Visnukumar⁶, R.Viswanathan⁷

Professor, Department of Electrical and Electronics Engineering, Gnanamani College of Technology, Namakkal, India¹
Asst. Professor, Department of Electrical and Electronics Engineering, Gnanamani College of Technology, Namakkal, India^{2,3}
U.G. Students, Department of Electrical and Electronics Engineering, Gnanamani College of Technology, Namakkal, India⁴⁻⁷

Abstract—This paper describes the implementation of Proportional Integral controller for boost converter in Photo Voltaic system. The reason behind using PI controller is it removes the delay and provides fast control. There are many types of controller that can be used to implement the elegant and effective output. The PI stands for Proportional and Integral Controllers, which are designed to eliminate the need for continuous operator attention, thus provide automatic control to the system. In this paper the PI controller is used and the K_p and K_i gain value is calculated by using trial and error method. This paper is focusing on implementing PI controller to boost converter. The boost converter is mainly used for voltage step up operation. So, the output voltage is greater than the input voltage. The PWM signal generator is used for commutation purpose in boost converter. The boost converter model is simulated by using MATLAB/SIMULINK. The boost converter maintained the constant output voltage in the load.

Index Terms— Boost converter, PI controller, PWM generator, PV system.

I. INTRODUCTION

In many industrial applications, it is required convert a fixed DC voltage source into a variable DC voltage source, a DC to DC converter directly from DC to DC and is a simply known as DC converter. A DC converter can be considered as DC equivalent to an AC transformer with continuously variable turn's ratio like a transformer, it can be used to step down or step up a DC voltage source [1]. The DC converters are widely used for traction motor control in electric automobiles, trolley cars, marine hoists, forklift trucks and mine haulers. They provide smooth Acceleration control, high efficiency, and fast dynamic response [2]. The DC converters can be used regenerative braking of DC motors to return energy back into the supply, and this feature results in energy savings for transportation systems with frequent stops [3]. The DC converters are used in DC voltage regulators and also are used, in conjunction with an inductor, to generate a DC current source; especially for the current source inverter [4].

In this paper proportional integral (PI) controller is used and the boost converter is used for converting DC into DC then that voltage is used for some application for example load as motor mean it operates in constant voltage if that voltage needs continuously this paper is very suitable one [5]. The comparator is comparing the output voltage and

reference voltage then it will produce the error signal that error signal is passed to PI controller. The PI controller is used for controlling the voltage signal after that it will send to PWM generator then the PWM generator is used to tuning the K_p and K_i values from PI controller [6]-[9]. The PWM generator is used for commutating the duty cycle then the MOSFET is used for closed and open operation for boost converter [10], [11]. When the MOSFET is open the inductor gets energized if the MOSFET is closed the energy will goes to diode the diode operates only in forward direction the capacitor is used for removing the ripple component [11]. Then only the constant output voltage is maintained in load side [13].

II. BOOST CONVERTER

In a boost regulator the output voltage is greater than the input voltage hence the name "boost", The Fig.1.shows the basic boost converter circuit diagram. In the boost converter the power MOSFET used as a switch. The circuit operation can be divided into two modes. Mode-1 begins when MOSFET switch is tuned ON at t=0. The input current, which rises, flows through inductor L and MOSFET switch. Mode-2 begins when MOSFET switch is tuned OFF at t=t₁. The current that was flowing through the MOSFET would now flow through L, C, load and diode D. The inductor current falls until MOSFET switch is turned ON again in the next cycle. The energy stored in inductor L is transferred to the load [14]-[18].

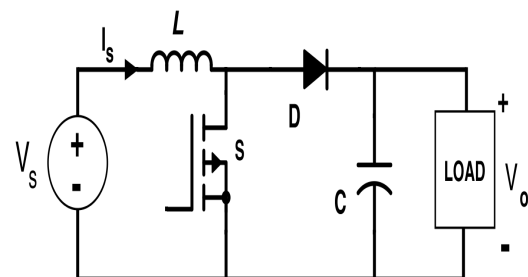

Fig.1. Boost Converter

III. CIRCUIT DIAGRAM

The circuit diagram consists of three main parts they are boost converter, PI controller and PWM generator. Initially the voltage is maintained constantly after that again it feeds to boost regulator through PI controller and PWM generator. The output voltage is giving to the comparator that comparator compares the reference signal and the output error signal from comparator is given to the PI controller, the PI controller control the output voltage after that PWM generator operates it will commute the MOSFET duty cycle [19].

Boost converter is used to convert DC to DC source basically the solar panel is converting heat energy into DC voltage. The output voltage is constant by Proportional Integral controller; it is used to controlling the output voltage. The PWM generator is used to commutating the angle of MOSFET. The error signal is getting from comparator. Again the output voltage is continuously getting as a constant output voltage [6].

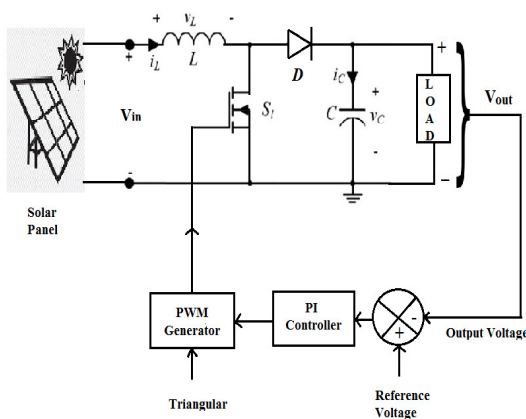

Fig.2. Circuit Diagram

The Fig.2.shows the circuit diagram of boost converter. When the switch is opened the inductor gets charged after closed the switch inductor charge will goes to the diode and the diode only conducted in forward biasing after that capacitor removes the ripple component.

IV. PI CONTROLLER

The addition of integral feedback can be used to eliminate the steady state error and reduce the forward gain required. To obtain this integral component the proportional speed controller is replaced by a PI type controller. With proportional band, the controller output is proportional to the error or a change in measurement (depending on the controller). Controller output = (error)*100/ (proportional band). With a proportional controller offset (deviation from set-point) is present. Increasing the controller gain will make the loop go unstable. Integral action was included in controllers to eliminate this offset. The Integral (I) with integral action, the controller output is proportional to the amount of time the error is present. Integral action eliminates offset. Controller output = (1/integral) (Integral of) e(t) dt.

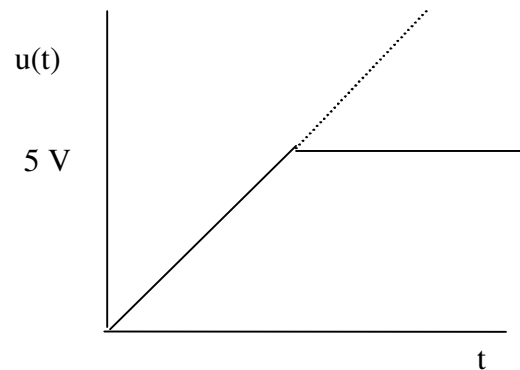

Fig.3. Proportional Band (P)

The process of selecting controller parameter to meet given performance specification is known as controller tuning. Ziegler and Nichols suggested rules for tuning PI controller (mean to set the values of Kp and Ki) based on the experimental step response or based on the value of Kp that result is marginal stability, when only proportional control action is used. Ziegler-Nichols rules, which are briefly presented in the following, are useful when mathematical models of plants are not known. These rules can, of course, be applied to design of system with known mathematical models. Such rules suggest a set of values of Kp and Ki that will give a stable operation of the system. However, the resulting system may exhibit a large maximum overshoot in step response, which is unacceptable. In such a case, we need series of fine tunings until an acceptable result is obtained. In fact, the Ziegler-Nichols tuning rules give an educated guess for parameter values and provide a starting point for fine tuning, greater than giving the final settings for Kp and Ki in a single shot. The Fig.3 shows the proportional band of the controller.

V. PULSE WIDTH MODULATION

Pulse width modulation is a very efficient way of providing intermediate amounts of electrical power between fully on and fully off. A simple power switch with a typical power source provides full power only, when switched on. PWM is a comparatively recent technique, made practical by modern electronic power switches. The microcontroller, ATmega8 has 3 timers /counter. Among them, timer/counter 1 and 2 are featured with PWM. We have used timer/counter2 (8-bit) to generate PWM for maintained output voltage remains constant. We used Phase correct mode here. Again, it has 2 different mode of operation, such as inverted and non-inverted mode. Non-inverted mode is used here.

The PWM generator block generates pulses for carrier-based pulse width modulation converters using two-level topology. The block can be used to fire the forced-commutated devices (FETs, GTOs, or IGBTs) of single-phase, two-phase, three-phase, two-level bridges or a combination of two three-phase bridges.

The pulses are generated by comparing a triangular carrier waveform to a reference modulating signal. The

modulating signals can be generated by the PWM generator itself, or they can be a vector of external signals connected at the input of the block. One reference signal is needed to generate the pulses for a single- or a two-arm bridge, and three reference signals are needed to generate the pulses for a three-phase, single or double bridge [20].

The amplitude (modulation), phase, and frequency of the reference signals are set to control the output voltage (on the AC terminals) of the bridge connected to the PWM generator block.

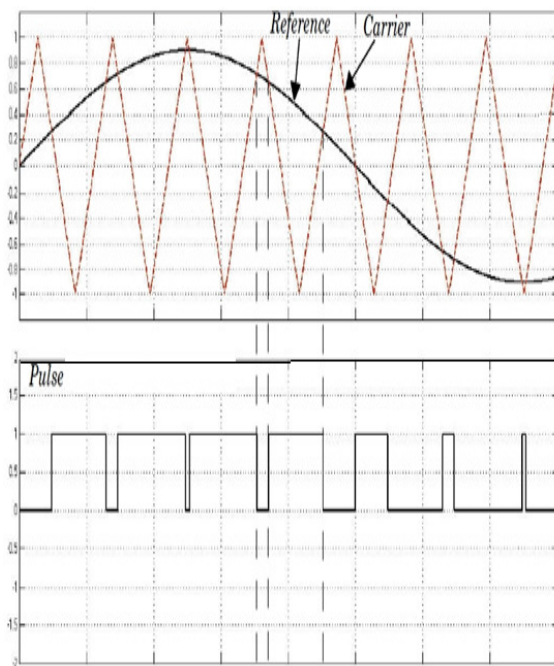

Fig.4. PWM signals

The Fig.4.shows the PWM signals generator of the boost converter. DC to AC converters is known as inverters. The function of an inverter is to change a DC input voltage to a symmetric AC output voltage of desired magnitude and frequency. The output voltage could be fixed or variable at a fixed or variable frequency. A variable output voltage can be obtained by varying the input DC voltage maintains the gain of the inverter constant. On the other hand if the DC input voltage is fixed and it is not controlled, A variable output voltage can be obtained by varying the gain of the inverter which is normally accomplished by pulse width modulation control within the inverter. The inverter gain many be defined as the ratio of the output AC voltage to DC input voltage.

The output voltage waveform of ideal inverter should be sinusoidal .However the waveforms of practical inverters or non-sinusoidal and contain certain harmonics for low and medium power application square wave or quasi square wave voltage may be acceptable and for high power application, low distorted sinusoidal waveforms are required. Which the availability of high frequency power semiconductor devices harmonic contents of output voltage can be minimized significantly by using switching techniques.

Inverter are widely used in industrial applications, such as variable –speed AC motor drives, induction heating standby power supplies and uninterruptible power supplies, the input may be battery, fuel cell, solar cell or other DC source. Inverters can be broadly classified into two categories such as single phase inverters and Three phase inverters, each type can use controlled turn on and turn off devices (e.g., bipolar junction transistor [BJTs], metal oxide field effect transistors [MOSFETS], insulated gate bipolar transistor [IGBTs], metal oxide semiconductor controlled thyristor.

VI. SIMULATION

The MATLAB simulation shows in Fig.5. In that model the IGBT is used as a switch for the best performance of voltage control, fast switching and low losses. Here initially given input supply voltage is 6V. In that supply voltage will be boosted and maintain the constant output voltage by using boost converter. To take the constant RL load for this simulation model. There are three boost converter parameters are monitoring by using displays. Here the freewheeling diode to maintain the continuous current path in the input supplies. The discrete PI controller gain is chosen by the trial and error method. In that PI controller output is act as the modulation index of the converter. The relational operator can be comparing the reference signal to the carrier signal. To set the maximum reference value of PI controller output is 0.4V. When the carrier signal voltage is more than reference voltage that time IGBT go to OFF or 0 states. Otherwise the IGBT maintain the ON or 1 state.

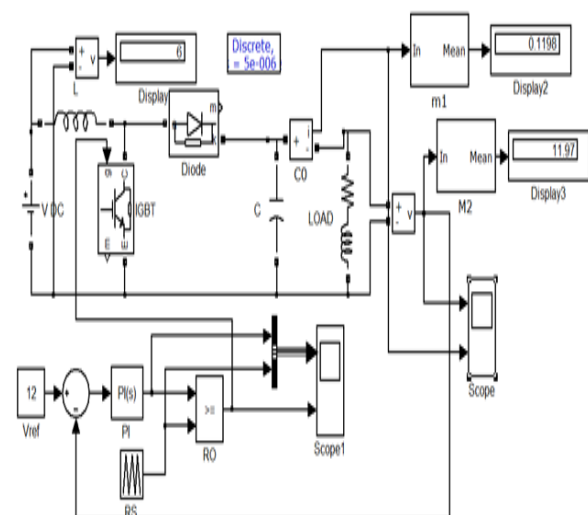

Fig.5. Simulation Model

The simulation circuit is necessary to get the output waveform. In input side we are giving 6V that voltage is getting in output side as 12V. For the PWM generation we have given two signals one is PI controller signal and other is a triangular carrier signal and the output of the PWM generator signal is given to the switch. The Fig.6 shows the PI controller signal and PWM signal, the scope-1 has comparing two signals from input side and getting the carrier wave and PI



controller wave thereby we get PWM wave as output. The scope-2 has the output voltage and current waveform, the Fig.7 shows the output voltage and current waveform of the boost converter.

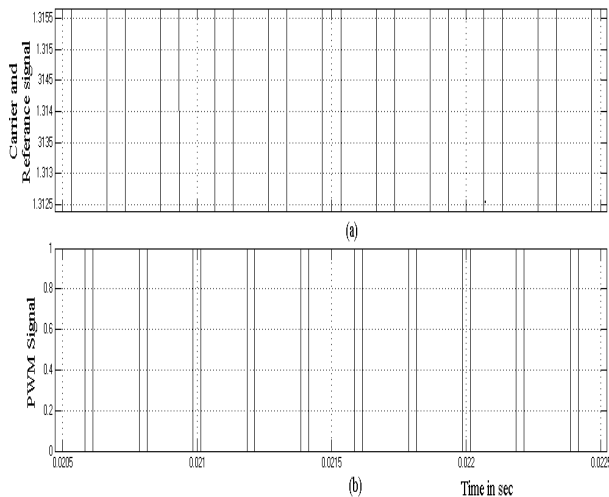

Fig.6. PWM Generate (a) PI controller signal and (b) PWM Pulses

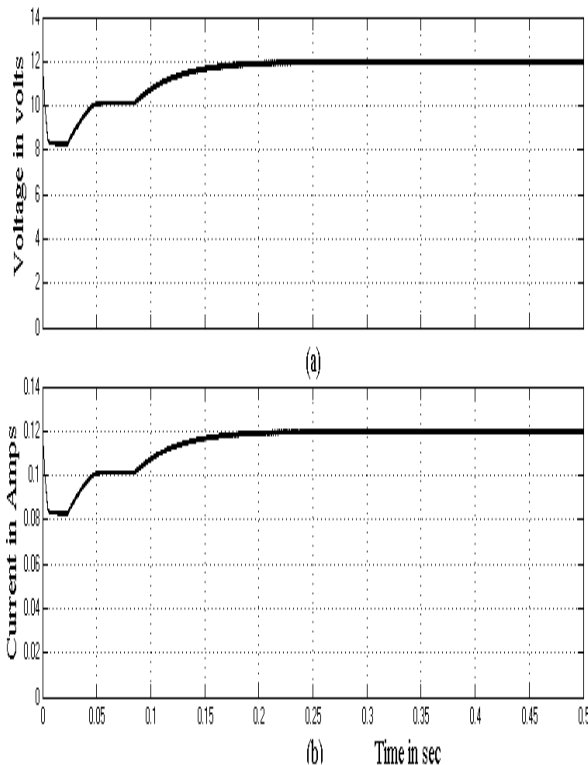

Fig.7. Simulation output (a) Voltage waveform and (b) Current waveform

CONCLUSION

In this work the boost converter is mainly used for constant output voltage application. The proportional integral control is used for controlling the output voltage of the boost converter, by tuning the K_p and K_i values of the controller. The carrier signal, PI controller signal and PWM pulses are

plotted in the scope, whenever the solar gets heat energy that energy will maintain constant voltage in the load. The simulated output voltage and current waveform gives the good responsibility of the boost converter.

REFERENCES

- [1] R. Gules, J. D. P. Pacheco, H. L. Hey, and J. Imhoff, "A maximum power point tracking system with parallel connection for PV stand-alone applications," *IEEE Transactions on Industrial Electronics*, vol. 55, no. 7, pp. 2674–2683, 2008.
- [2] J. M. Kwon, B. H. Kwon, and K. H. Nam, "Grid-connected photovoltaic multi string PCS with PV current variation reduction control," *IEEE Transactions on Industrial Electronics*, vol. 56, no. 11, pp. 4381–4388, 2009.
- [3] A. Pandey, N. Dasgupta, and A. K. Mukerjee, "A simple single sensor MPPT solution," *IEEE Transactions on Power Electronics*, vol. 22, no. 2, pp. 698–700, 2007.
- [4] I. Hong, B. Kang, and S. Park, "Design and implementation of intelligent energy distribution management with photovoltaic system," *IEEE Transactions on Consumer Electronics*, vol. 58, no. 2, pp. 340–346, 2012.
- [5] C. H. Lin, C. Y. Hsieh, and K. H. Chen, "A li-ion battery charger with smooth control circuit and built-in resistance compensator for Achieving stable and fast charging," *IEEE Transactions on Circuits and Systems I*, vol. 57, no. 2, pp. 506–517, 2010.
- [6] R. Nagarajan, S.Sathiskumar, K.Balasubramani, C.Boobalan, S.Naveen, and N.Sridhar. "Chopper Fed Speed Control of DC Motor Using PI Controller," *IOSR, Journal of Electrical and Electronics Engineering (IOSR-JEEE)* vol. 11, no. 3, pp. 65–69, 2016.
- [7] E. Koutroulis and K. Kalaitzakis, "Novel battery charging regulation system for photovoltaic applications," *IEE Proceedings— Electric Power Applications*, vol. 151, no. 2, pp. 191–197, 2004.
- [8] R.Nagarajan and M,Saravanan. "Performance Analysis of a Novel Reduced Switch Cascaded Multilevel Inverter," *Journal of Power Electronics*, Vol.14, No.1, pp.48-60. 2014.
- [9] T. S. Mundra and A. Kumar, "Micro power battery state-of charge monitor," *IEEE Transactions on Consumer Electronics*, vol. 54, no. 2, pp. 623–630, 2008.
- [10] C. Yao, X. Ruan, X. Wang, and C. K. Tse, "Isolated buck-boost DC/DC converters suitable for wide input-voltage range," *IEEE Transactions on Power Electronics*, vol. 26, no. 9, pp. 2599–2613, 2011.
- [11] R.Nagarajan and M,Saravanan "Staircase Multicarrier SPWM Technique for Nine Level Cascaded Inverter," *Proceedings of the International Conference on Power, Energy and Control*, IEEE Press, pp-668-675. 2013.
- [12] Q. Mei, M. Shan, L. Liu, and J. M. Guerrero, "A novel improved variable step-size incremental-resistance MPPT method for PV systems," *IEEE Transactions on Industrial Electronics*, vol. 58, no. 6, pp. 2427–2434, 2011.
- [13] Y. Sonmez, M. Dursun, U. Guvenc, and C. Yilmaz, "Startup current control of Buck-Boost converter-fed serial DC motor," *Pamukkale Univ. J. Eng. Sci.*, vol. 15, no. 2, pp. 278–283, May 2009.
- [14] J. Linares-Flores, J. L. Barahona-Avalos, H. Sira-Ramírez, and M. A. Contreras-Ordaz, "Robust passivity-based control of a Buck-Boost converter/DC-motor system: An Active disturbance rejection approach," *IEEE Trans. Ind. Appl.*, vol. 48, no. 6, pp. 2362–2371, Nov./Dec. 2012.
- [15] E. E. Jimenez-Toribio, A. A. Labour-Castro, F. Muniz-Rodríguez, H. R. Perez-Hernández, and E. I. Ortiz-Rivera, "Sensorless control of Sepic and Cuk converters for DC motors using solar panels," in *Proc. IEEE Int. Electr. Mach Drives Conf.*, Miami, FL, USA, May 3–6, 2009, pp. 1503–1510.
- [16] J. Linares-Flores, H. Sira-Ramírez, E. F. Cuevas-Lopez, and M. A. Contreras-Ordaz, "Sensorless passivity based control of a DC motor via a solar powered Sepic converter-full bridge combination," *J. Power Electron.*, vol. 11, no. 5, pp. 743–750, Sep. 2011.



- [17] A. W. Divelbiss and J. T. Wen, "Trajectory tracking control of a car-trailer system," *IEEE Trans. Control Syst. Technol.*, vol. 5, no. 3, pp. 269–278, May 1997.
- [18] J. Linares-Flores, J. Reger, and H. Sira-Ramírez, "Load torque estimation and passivity-based control of a Boost-converter/DC-motor combination," *IEEE Trans. Control Syst. Technol.*, vol. 18, no. 6, pp. 1398–1405, Nov. 2010.
- [19] R.Nagarajan and M,Saravanan "A Carrier - Based Pulse Width Modulation Control Strategies for Cascaded Multilevel Inverter" *International Review on Modeling and Simulations*, Vo.6. No.1, pp-8-19. 2013.
- [20] R.Nagarajan and M,Saravanan "Comparison of PWM Control Techniques for Cascaded Multilevel Inverter" *International Review of Automatic control*, Vol.5 No.6, pp. 815-828. 2012.



R. Nagarajan received his B.E. in Electrical and Electronics Engineering from Madurai Kamarajar University, Madurai, India, in 1997. He received his M.E. in Power Electronics and Drives from Anna University, Chennai, India, in 2008. He received his Ph.D in Electrical Engineering from Anna University, Chennai, India, in 2014. He has worked in the industry as an Electrical Engineer. He is currently working as Professor of Electrical and Electronics Engineering at Gnanamani College of Technology, Namakkal, Tamilnadu, India. His current research interest includes Power Electronics, Power System, Renewable Energy Sources and Soft Computing Techniques.



J.Chandramohan received his B.E. in Electrical and Electronics Engineering from Bharathiyar University

Coimbatore, India, in 2003. He received his M.E. in Power Electronics and Drives from Anna University, Coimbatore, India, in 2010. He is currently working toward his Ph.D. in Power System at Anna University Chennai, India. He is currently working as a Assistant Professor of Electrical and Electronics Engineering at Gnanamani College of Technology, Namakkal, Tamilnadu, India. His current research interest includes Power System and High Voltage Engineering.



S.Sathishkumar received his B.E. in Electrical and Electronics Engineering from Anna University, Tiruchirappalli, India, in 2011. He received his M.E. in Power Electronics and Drives from Anna University, Chennai, India, in 2014. He has worked in the industry as an Electrical Engineer. He is currently working as a Assistant Professor of Electrical and Electronics Engineering at Gnanamani College of Technology, Namakkal, Tamilnadu, India.