

WESC MINI-SYMPOSIUM

OWA GloBE: Building Industry Consensus on the Global Blockage Effect in Offshore Wind

24th May 2023

OWA Global Blockage Effects in Offshore Wind (GloBE)



Project Objective:

To measure and quantify the “Global Blockage Effect” (GBE) in order to achieve industry consensus.

Project Status:

Not quite there yet.
Verification and validation ongoing before wider industry consensus can be formed.

Objectives Of Mini-Symposium:

Deep-dive into the “what, why and how” of the project.
Elicit feedback that will strengthen project outcomes and help consensus-building.

Agenda



Chris Rodaway,
RWE Offshore Wind

Blockage: Background, Motivation and State of the Art



Chris Rodaway,
RWE Offshore Wind

Measurement Campaign Experimental Design



Dr Elliot Simon,
DTU Wind Energy

Mitigating Bias and Uncertainty in Offshore Wind LiDAR
Measurement Campaigns



Dr Julia Gottschall
Fraunhofer IWES

Verification of Offshore Scanning LiDAR Measurements using a
Floating Wind LiDAR System: the OWA-GloBE Case Study



Dr Graham Hawkes,
Frazer-Nash Consultancy

Rapid Blockage Model Development and Validation



Neil Adams,
Carbon Trust

Towards Industry Consensus on the Global Blockage Effect

Agenda



Chris Rodaway,
RWE Offshore Wind

Blockage: Background, Motivation and State of the Art



Chris Rodaway,
RWE Offshore Wind

Measurement Campaign Experimental Design



Dr Elliot Simon,
DTU Wind Energy

Mitigating Bias and Uncertainty in Offshore Wind LiDAR
Measurement Campaigns



Dr Julia Gottschall
Fraunhofer IWES

Verification of Offshore Scanning LiDAR Measurements using a
Floating Wind LiDAR System: the OWA-GloBE Case Study



Dr Graham Hawkes,
Frazer-Nash Consultancy

Rapid Blockage Model Development and Validation



Neil Adams,
Carbon Trust

Towards Industry Consensus on the Global Blockage Effect



OWA GLoBE: Background & Motivation

OWA GLoBE: Experimental Design

WESC 2023

24th May 2023



Supported by:



on the basis of a decision
by the German Bundestag

Computing resources were partly provided by
the North-German Supercomputing Alliance
(HLRN).



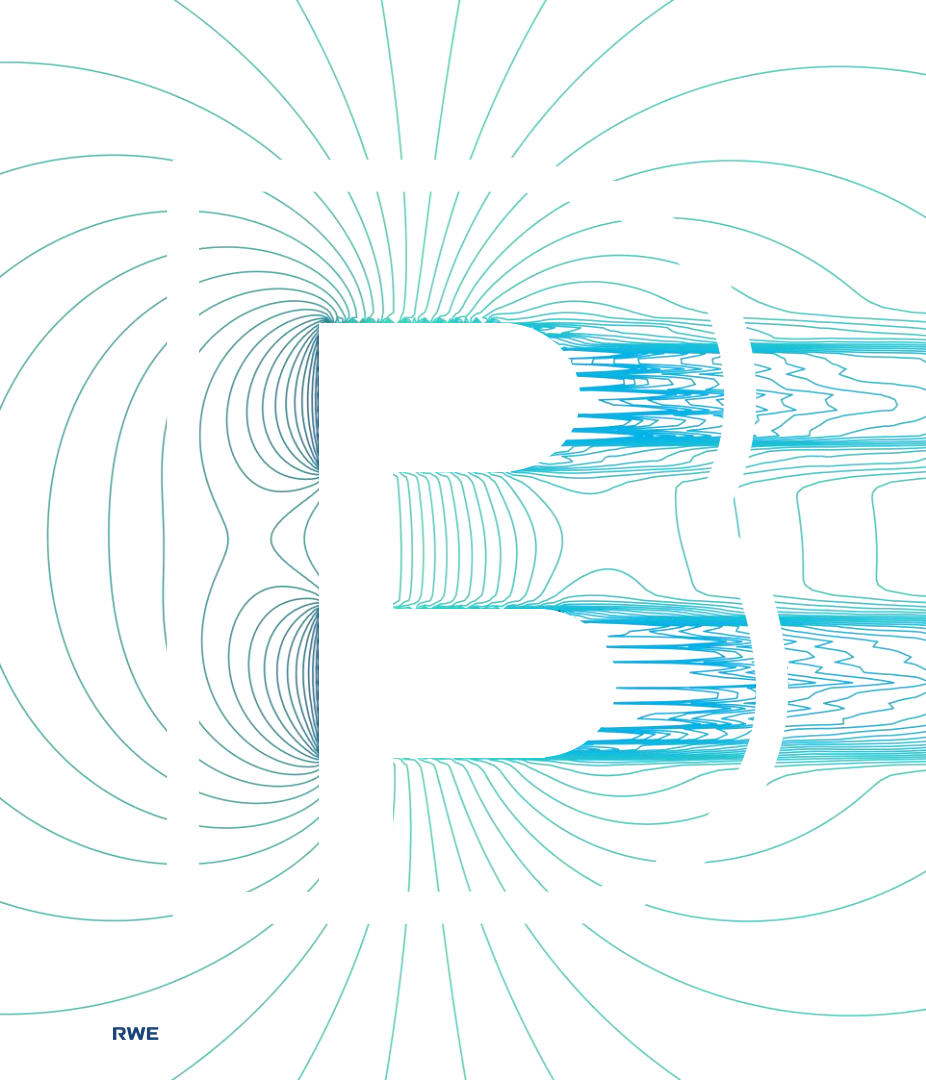

RWE | GLOBE

Global Blockage Effect



Background & motivation



GLOBE experimental design



Questions

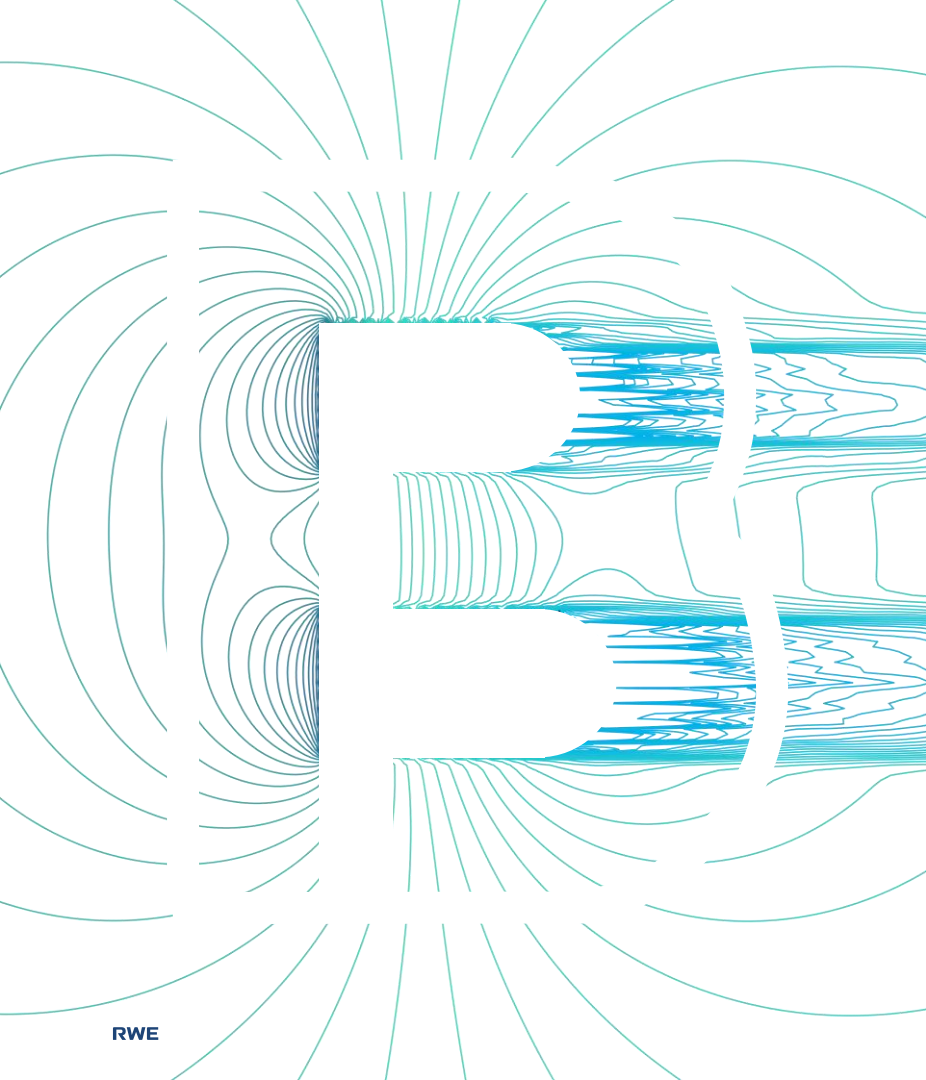

RWE | GLOBE

Global Blockage Effect



Background & motivation



GLOBE experimental design



Questions



The mechanics of blockage

Some definitions

Physical phenomenon

Blockage = Induction = Inviscid effects

Blockage leads to biases in power and its distribution depending on location relative to other objects that create a thrust.

Blockage is a complex 2-way interaction between the wind farm and surrounding atmosphere

Blockage scale

Blockage (inviscid) effects independent of scale whether at the turbine, intra-farm or inter-farm level

The nature of the tight coupling between inviscid and viscous effects means we should now be considering both in a single turbine interaction effect.

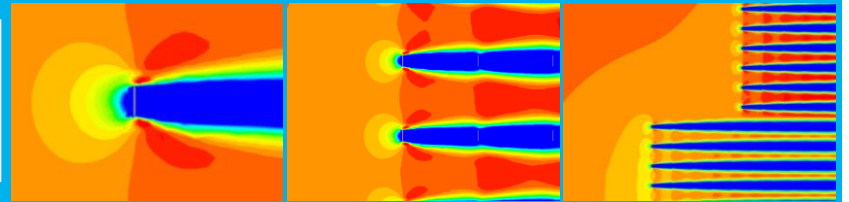



Reaching Consensus

Hypothesis testing

- H0** There is no GBE
- H1** GBE results only in a downwards bias in AEP
- H2** GBE results in a downwards or upwards bias in AEP
- H3** Geostrophic height (ABL) has little impact on GBE
- H4** Geostrophic height (ABL) has large impact on GBE

Legacy approach

Lead row correction approach

Fully-coupled approach

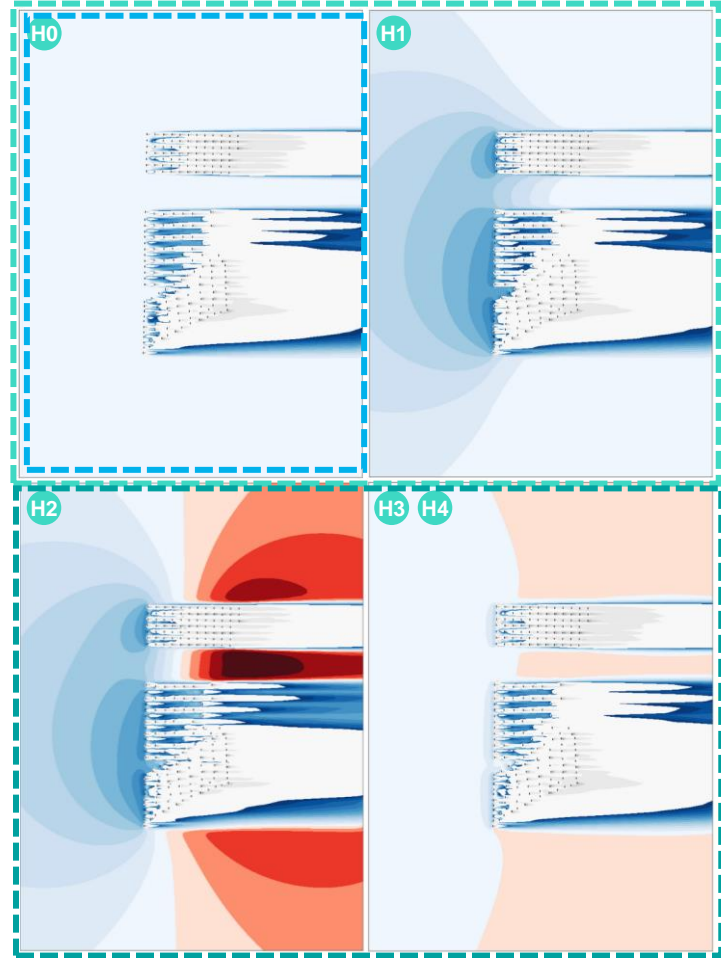



The necessary physics

The need for rapid models

- 1 RWE in-house developed “VV” (Viscous Vortex) tested against higher order models
- 2 No wake model “tuning” or coefficients required
- 3 VV is EV (Ainslie) coupled to vortex sheet (RHB)

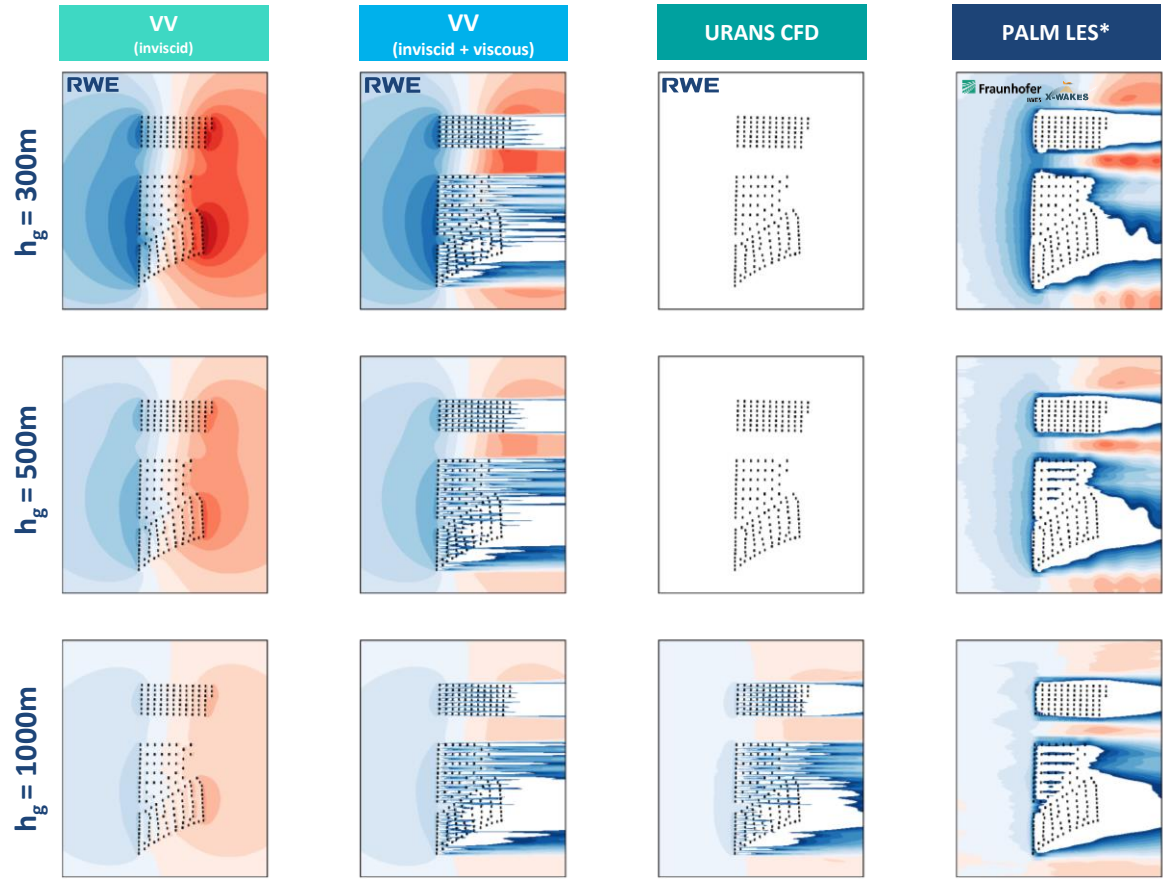
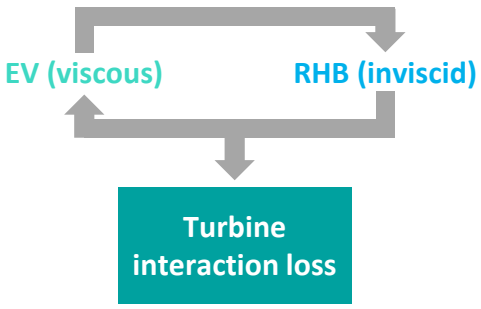



EXTRA: The necessary physics

The need for flexibility

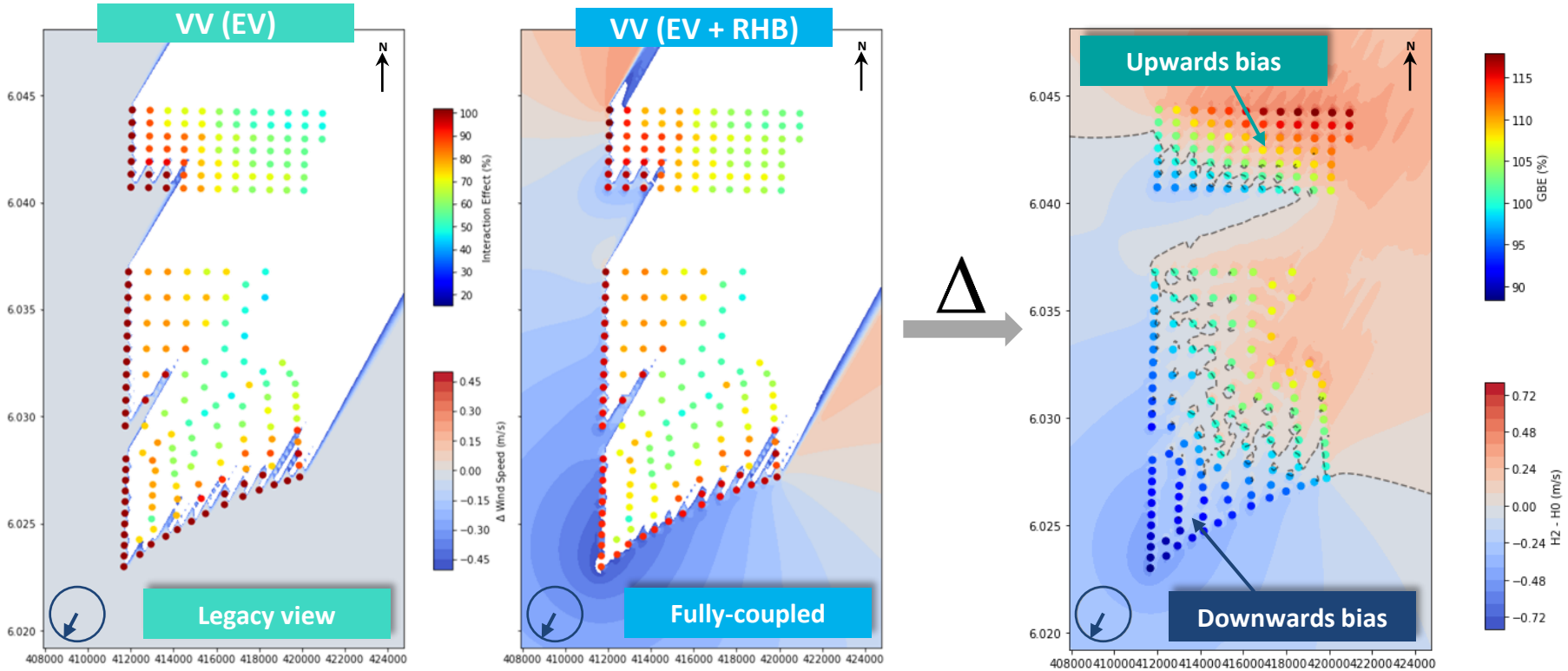



Pattern of Production Models vs SCADA

Key non-orthogonal directions

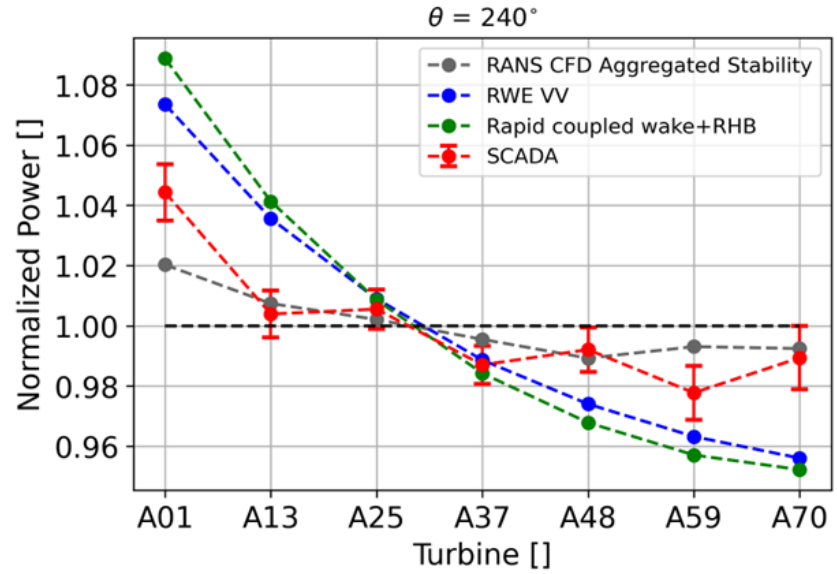

Criteria	Description
Wind speed	7.5±1 median from upwind WTGs
Wind direction	$\theta_{ref} \pm 5^\circ$ median from upwind WTGs
Filtering	All upwind turbines operating normally
Power norm	Denominator upwind WTG average

RWE

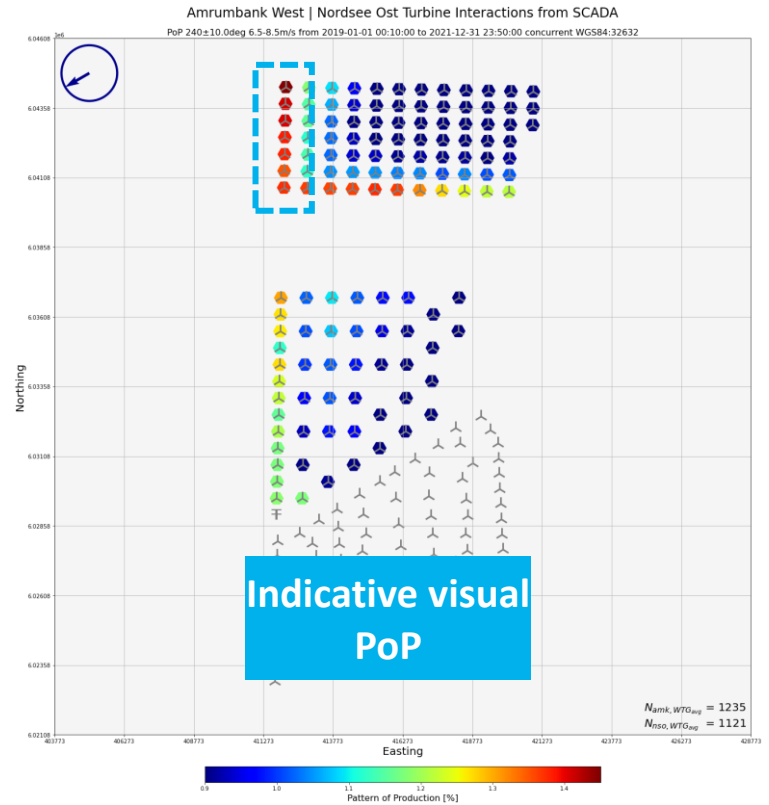



Pattern of Production Models vs SCADA

Key non-orthogonal directions

$\theta = 270^\circ$

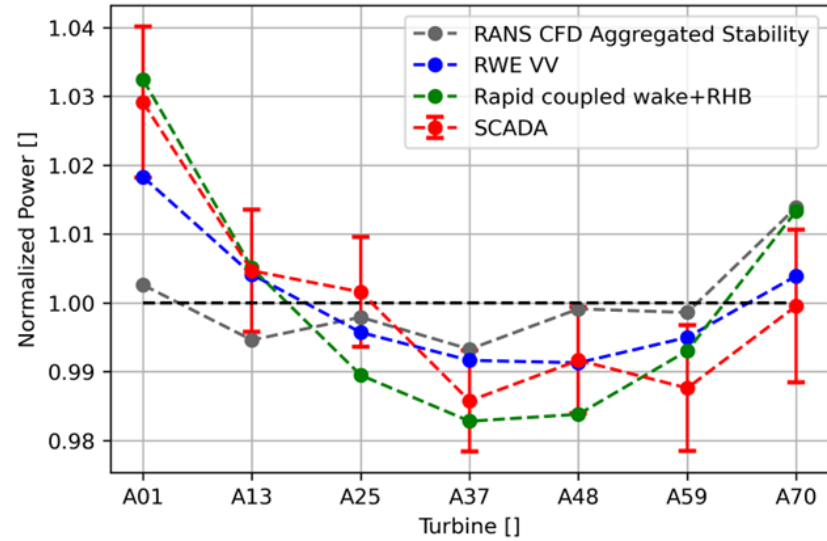

Criteria	Description
Wind speed	7.5±1 median from upwind WTGs
Wind direction	$\theta_{ref} \pm 5^\circ$ median from upwind WTGs
Filtering	All upwind turbines operating normally
Power norm	Denominator upwind WTG average

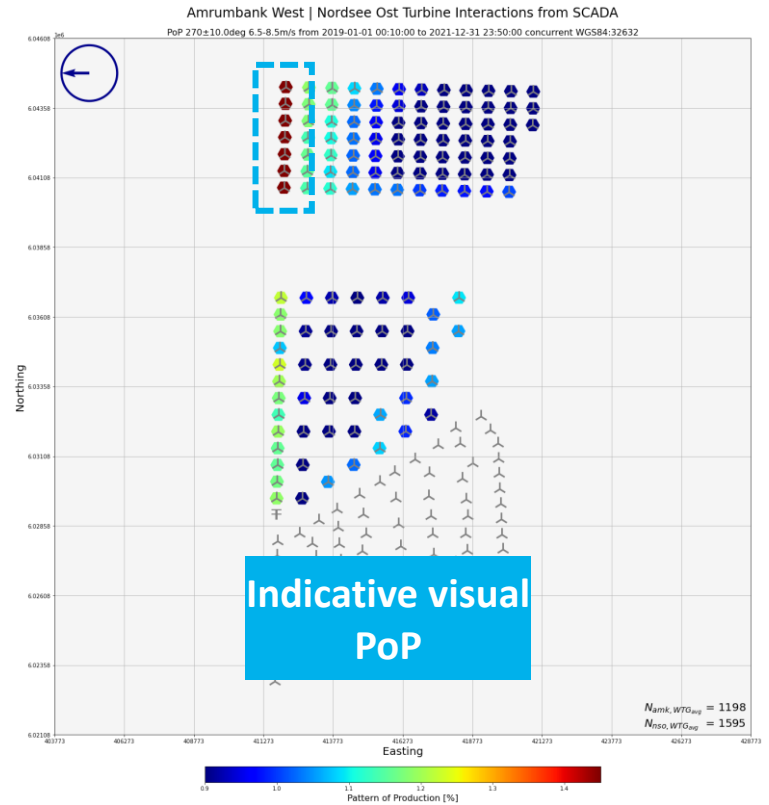



Pattern of Production Models vs SCADA

Key non-orthogonal directions

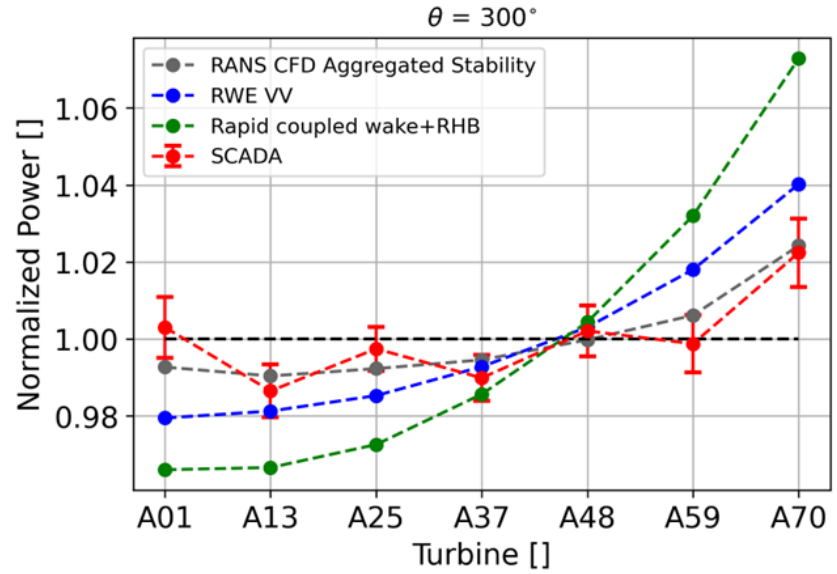

Criteria	Description
Wind speed	7.5±1 median from upwind WTGs
Wind direction	$\theta_{ref} \pm 5^\circ$ median from upwind WTGs
Filtering	All upwind turbines operating normally
Power norm	Denominator upwind WTG average

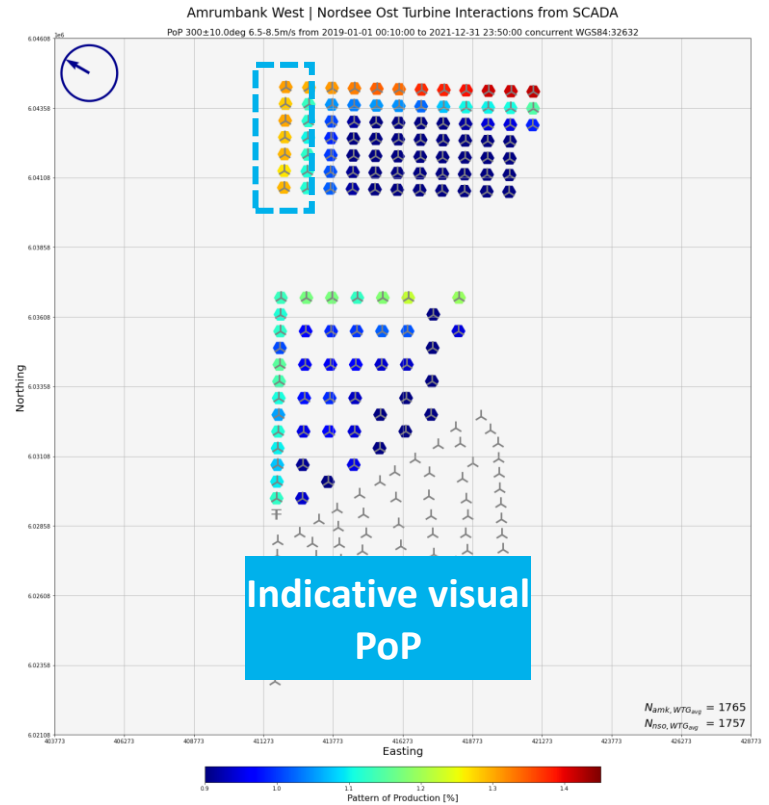



Pattern of Production Models vs SCADA

Key non-orthogonal directions

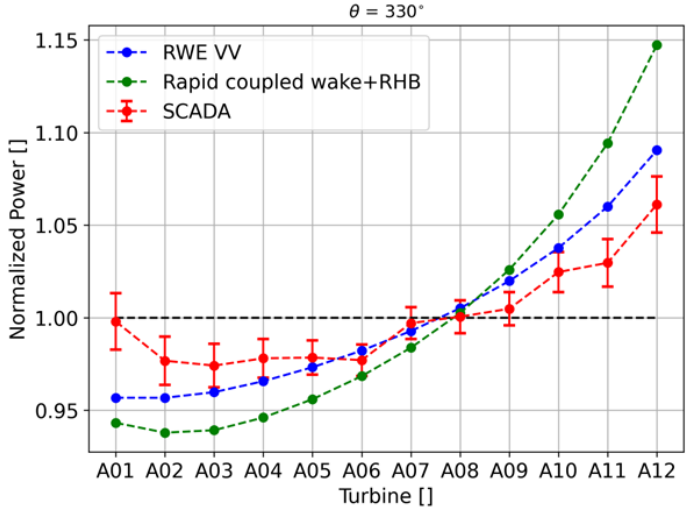

Criteria	Description
Wind speed	7.5±1 median from upwind WTGs
Wind direction	$\theta_{ref} \pm 5^\circ$ median from upwind WTGs
Filtering	All upwind turbines operating normally
Power norm	Denominator upwind WTG average

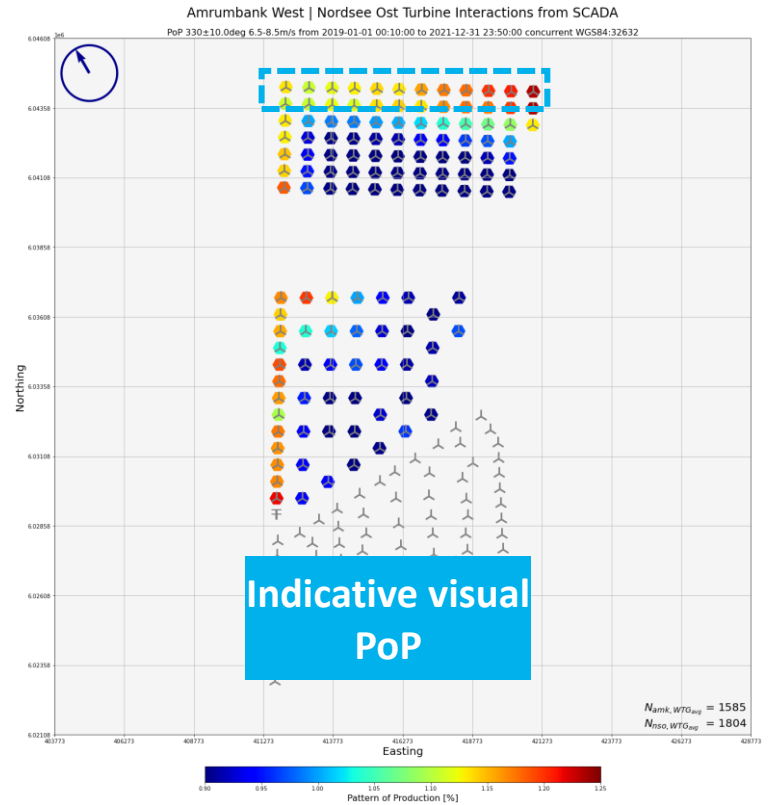



Pattern of Production Models vs SCADA

Key non-orthogonal directions

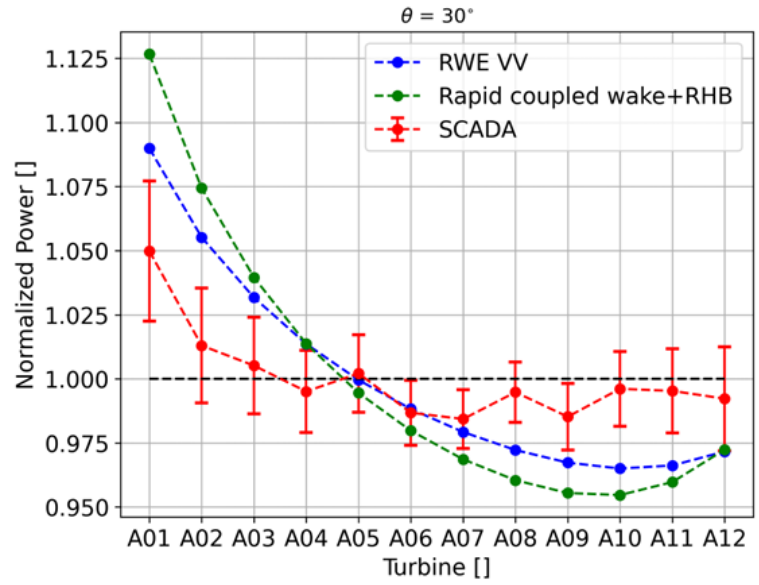

Criteria	Description
Wind speed	7.5±1 median from upwind WTGs
Wind direction	$\theta_{ref} \pm 5^\circ$ median from upwind WTGs
Filtering	All upwind turbines operating normally
Power norm	Denominator upwind WTG average

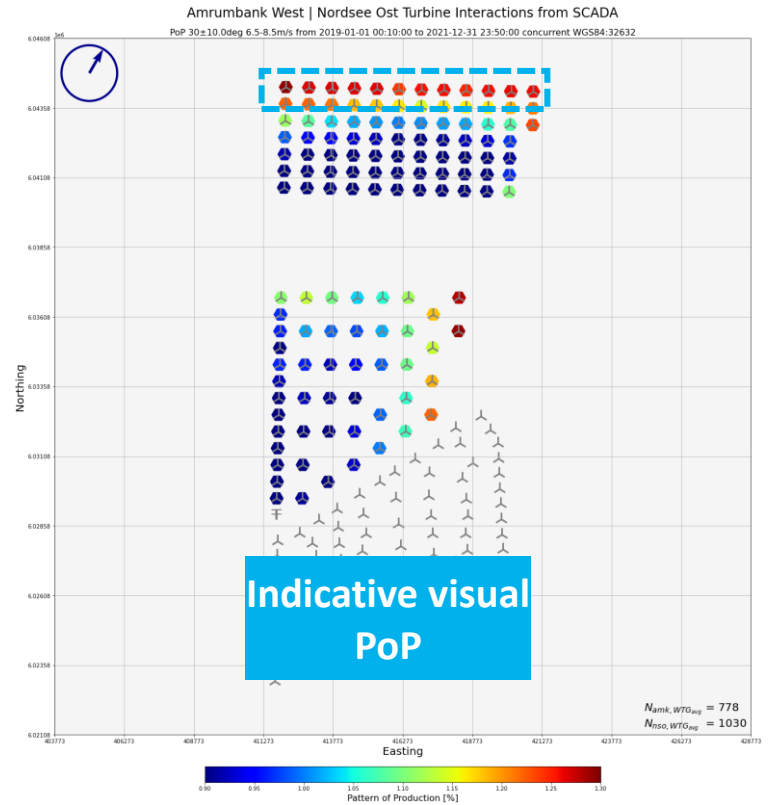

Pattern of Production Models vs SCADA

Key non-orthogonal directions

Rapid coupled wake+RHB

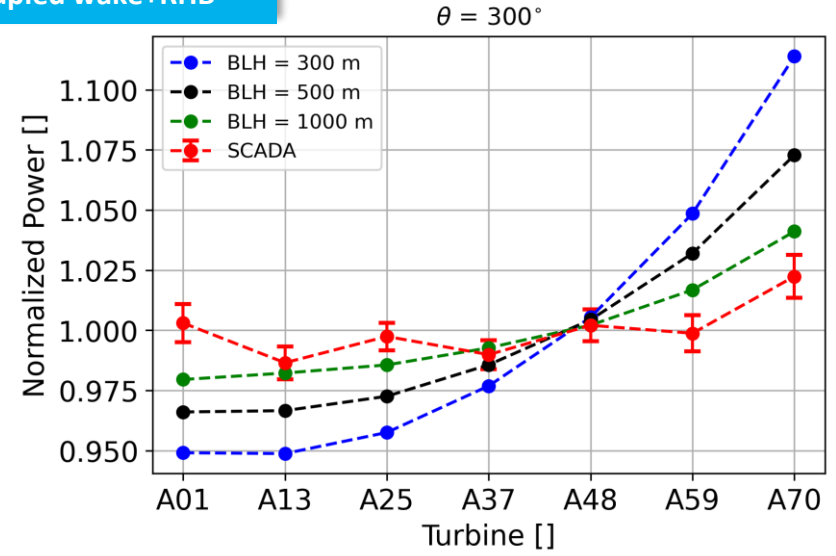
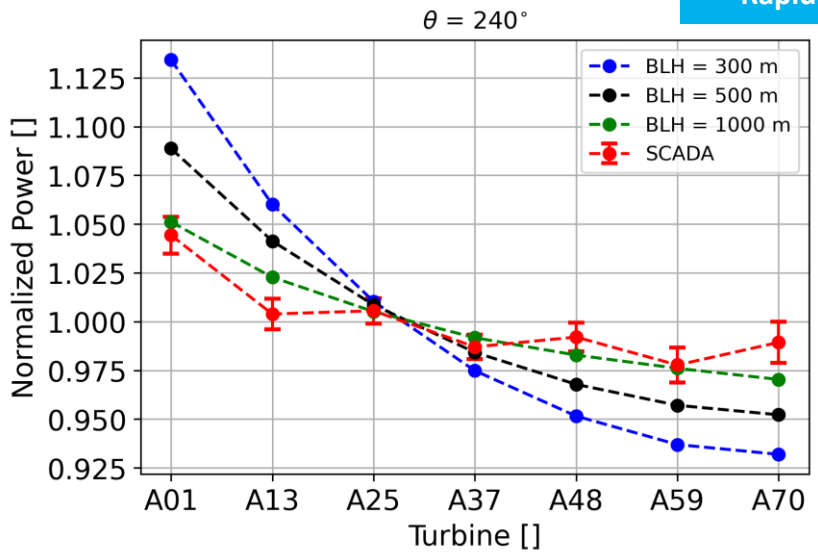

Modelling shows link between blockage extent and ABL height. Can this be seen in the SCADA data?



Impact of ABL on pattern of production

Filtering by ERA5 data

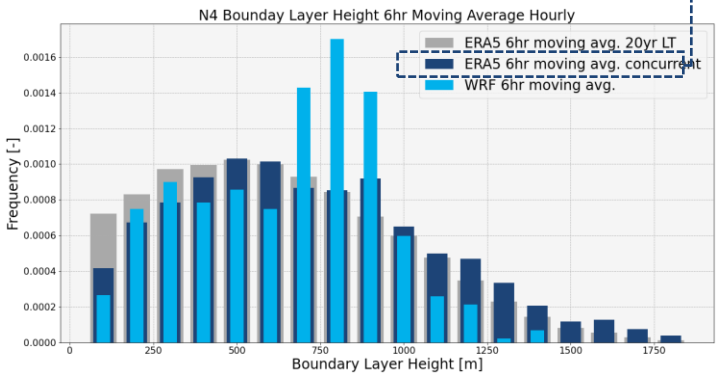
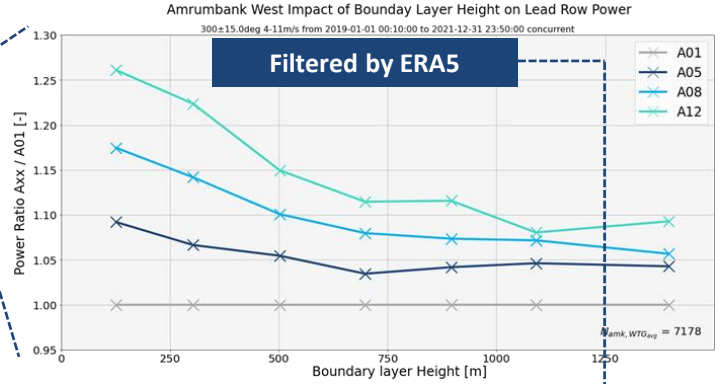
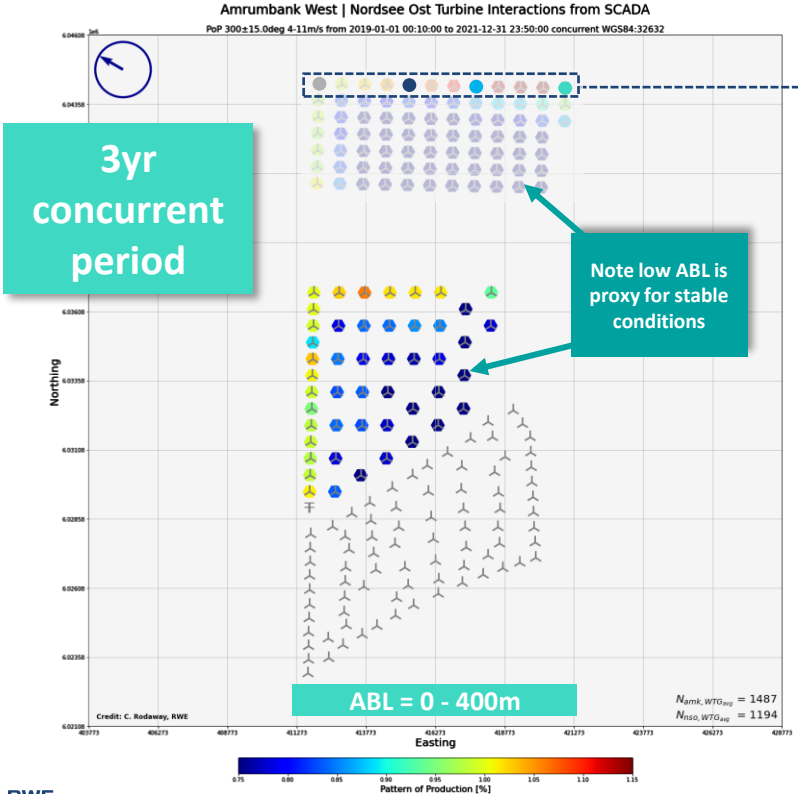



Impact of ABL on pattern of production

Filtering by WRF data

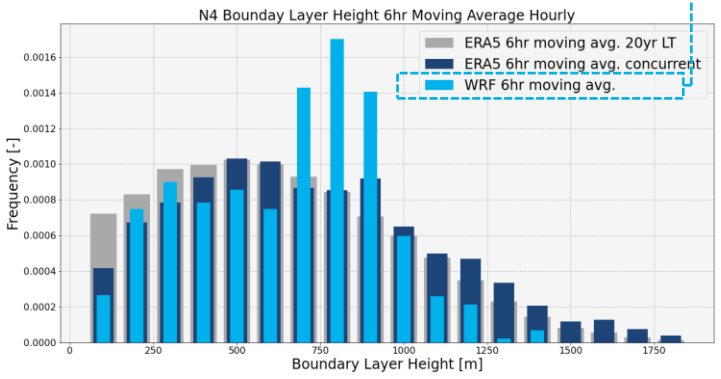
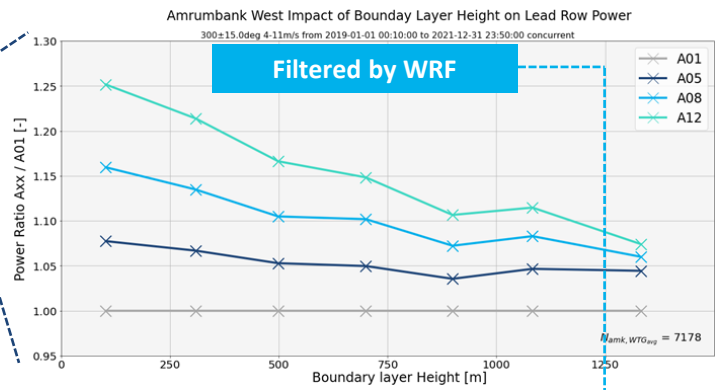
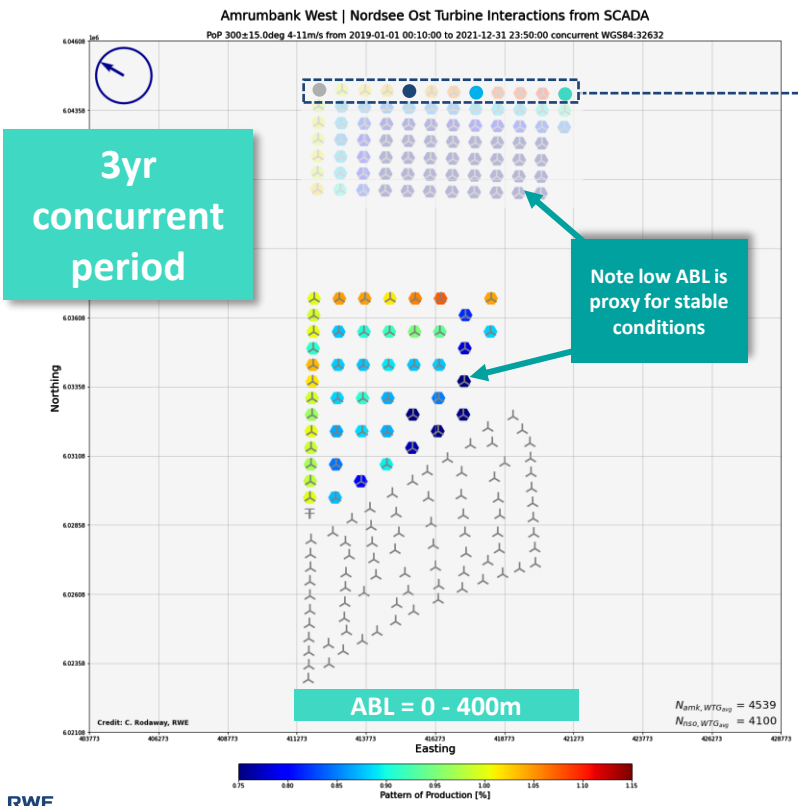

Impact of ABL on pattern of production

Comparing ABL height data sources

Filtered by ERA5

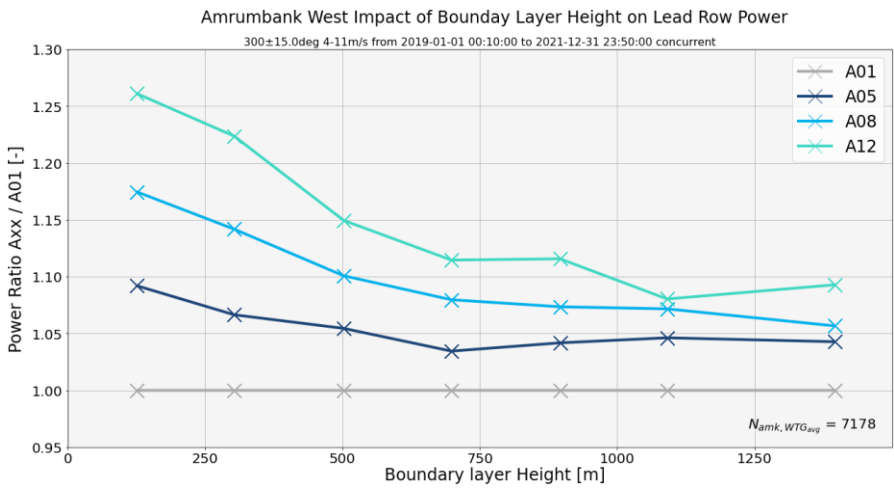

Filtered by WRF

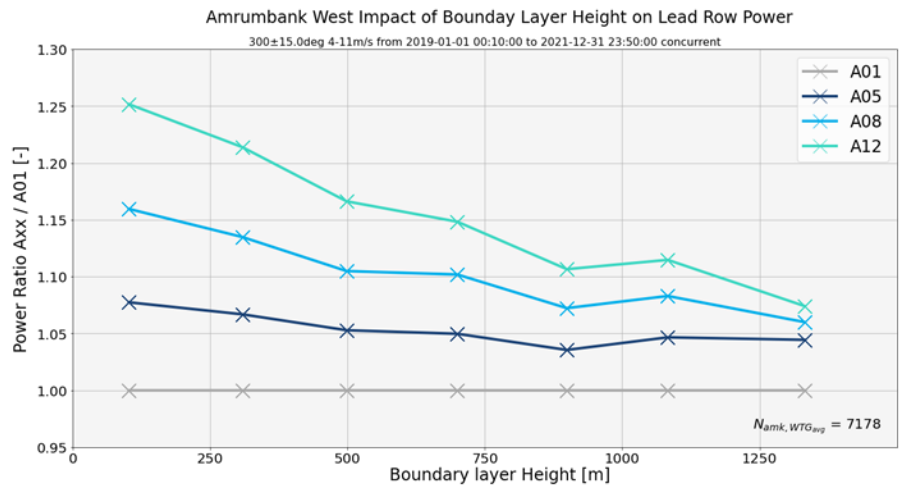



Importance of the physics

Impact on farms in large clusters

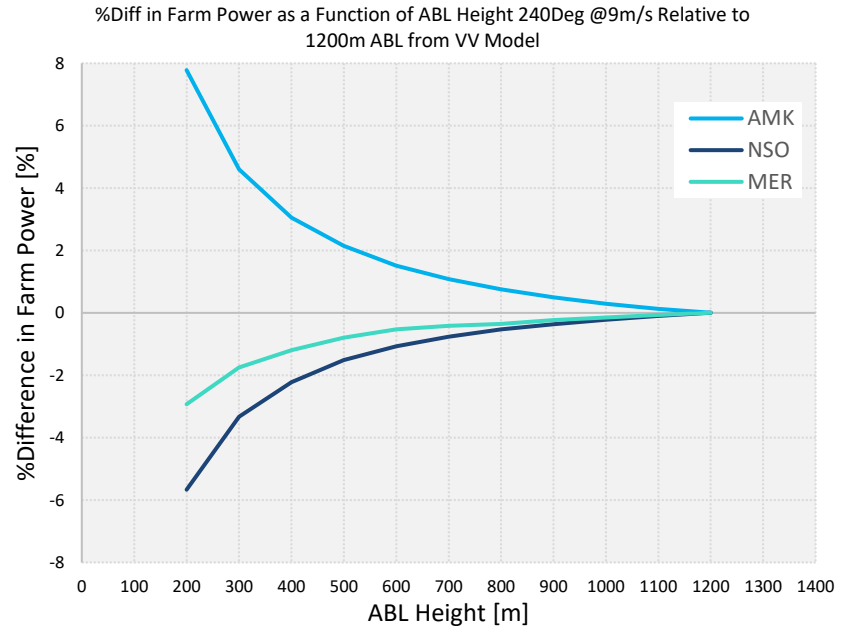
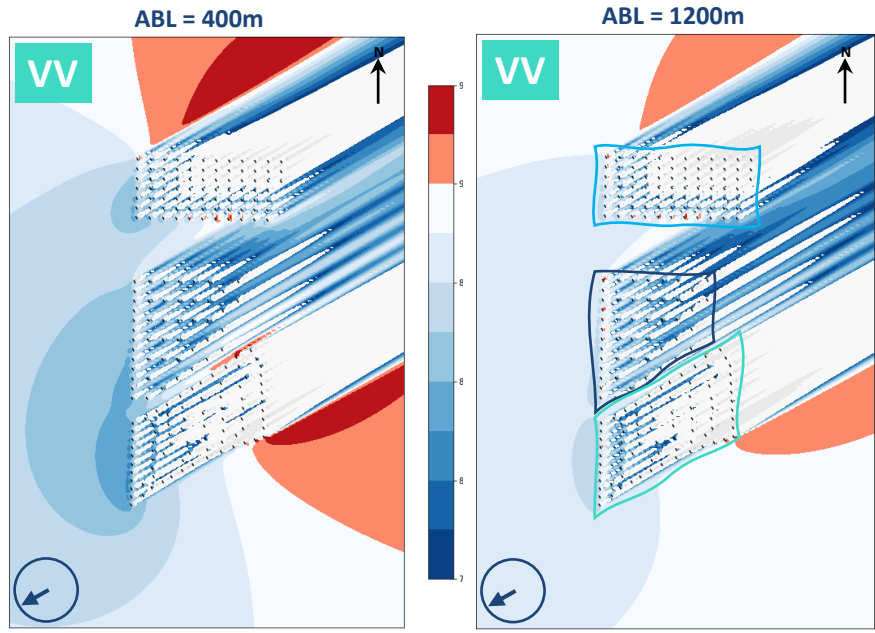

Farm-farm inviscid interactions can only be captured using a fully-coupled approach

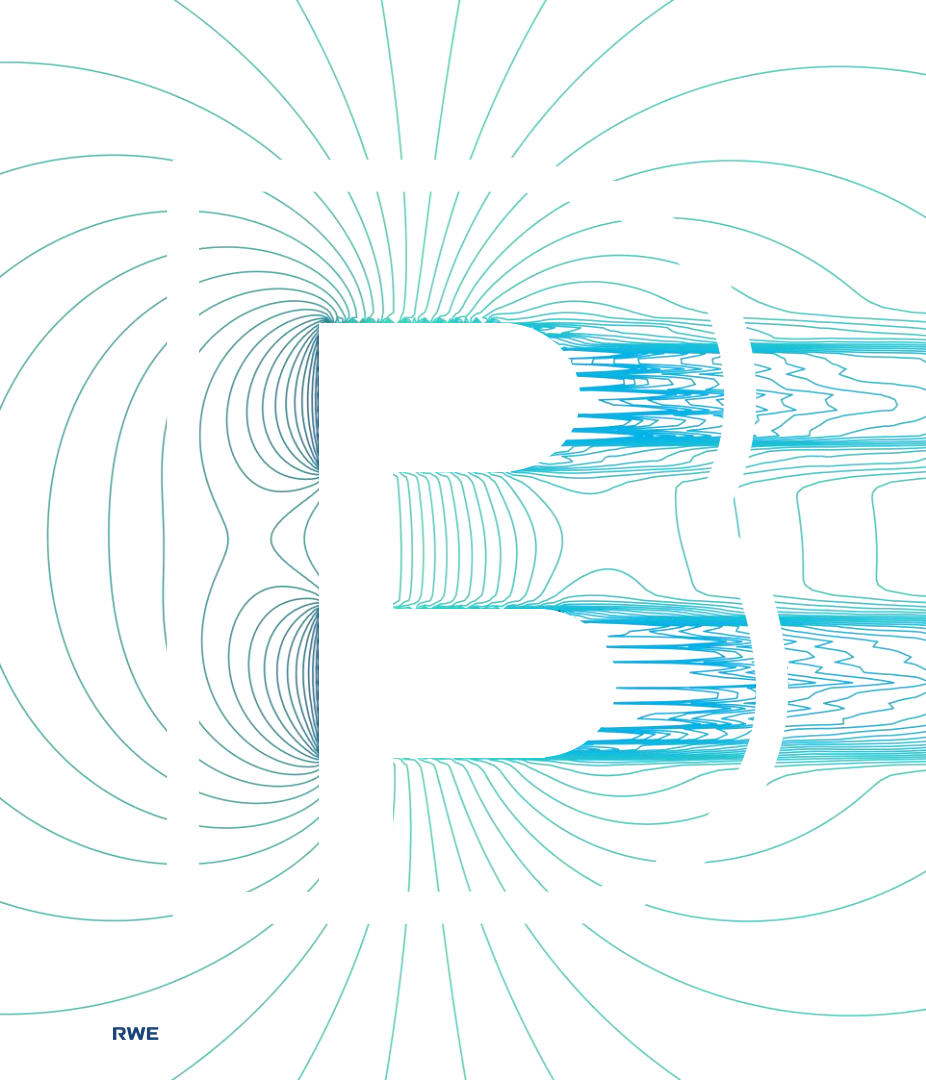

RWE | GLOBE

Global Blockage Effect



Background & motivation



GLOBE experimental design



Questions



Measurement campaign summary

Final design layout & measurement dimensions

1 6x WindCube 400s for blockage

GLOBE
Global Blockage Effect

Data processing in progress

2 1x WindCube 200s for ABL & tall profiles

Fraunhofer IWES + X-WAKES

Data processing complete

3 1x FLS for reference and calibration

Fraunhofer IWES + X-WAKES

Data processing complete

4 1x Respec. met mast for research

RWE + GLOBE
Global Blockage Effect

- Anemometers (1Hz)
- Vanes (1Hz)
- Geopane
- Ultrasonics (8Hz)
- Temp. Diff. (1Hz)
- Temp. (1Hz)
- SST (1Hz)
- ZX300M

Data processing complete

5 Concurrent & LT SCADA data from Amrumbank West & Nordsee Ost wind farms

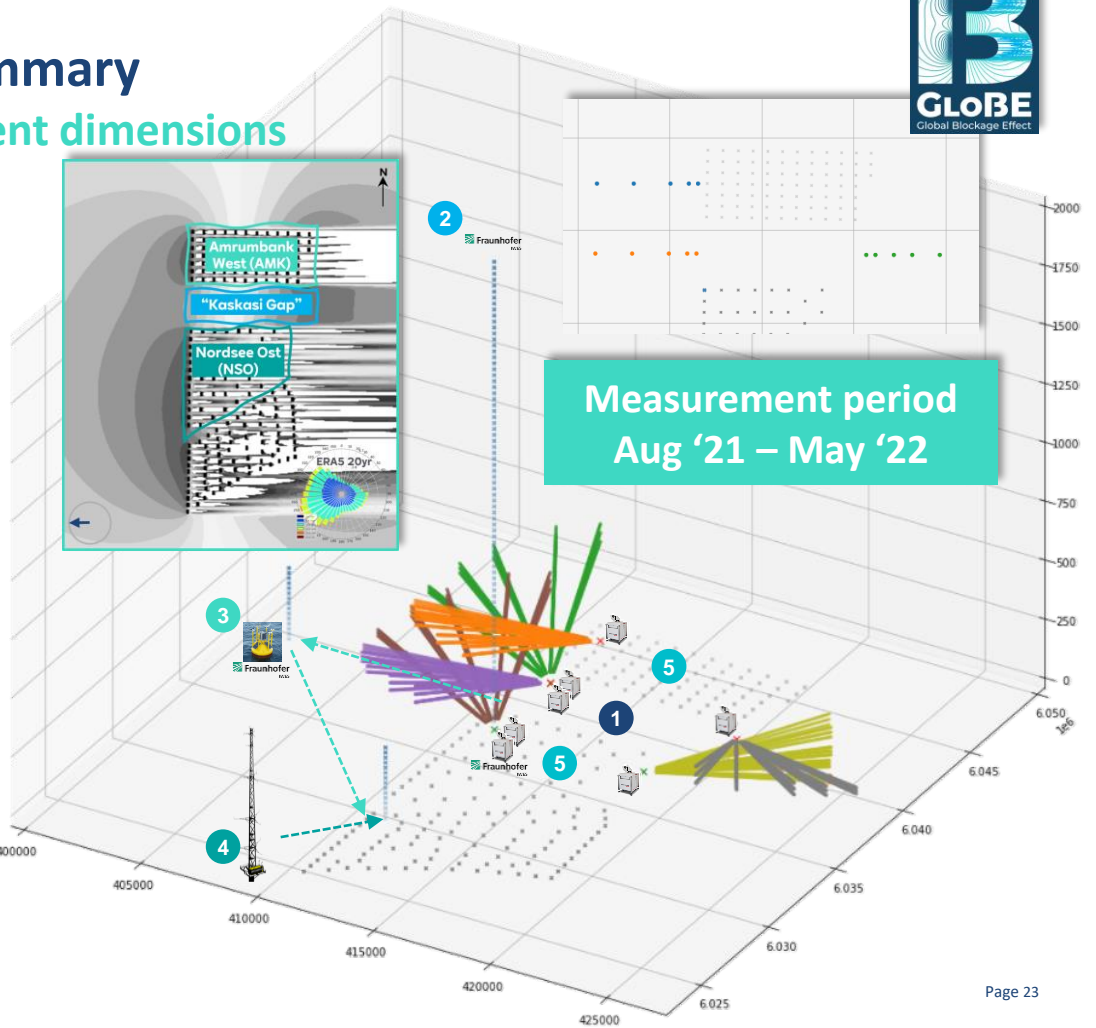



Device deployment

WindCube LiDARs

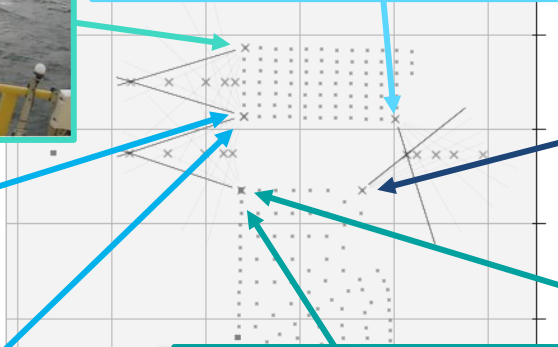
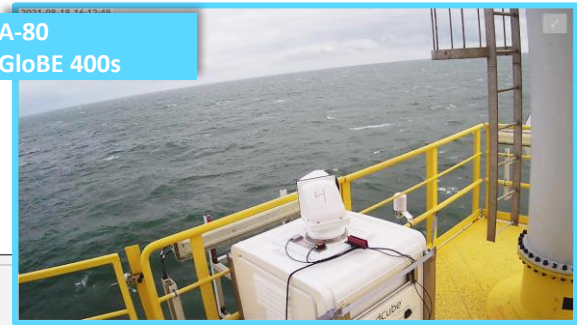



Device deployment

Met mast and floating LiDAR system



NSO
mast

At location C: Co-location
with NSO MM

FLS

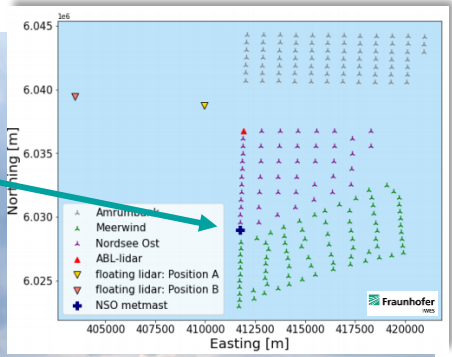



Sources of uncertainty & bias

Platform Tilt & Motion Correction

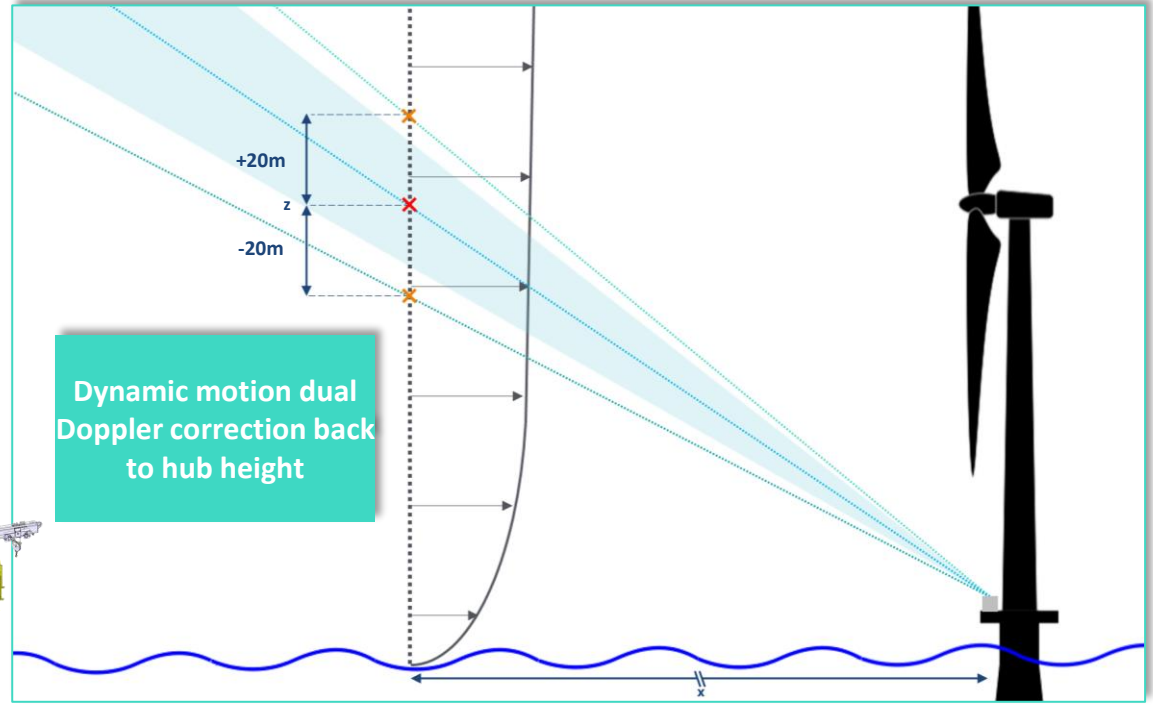
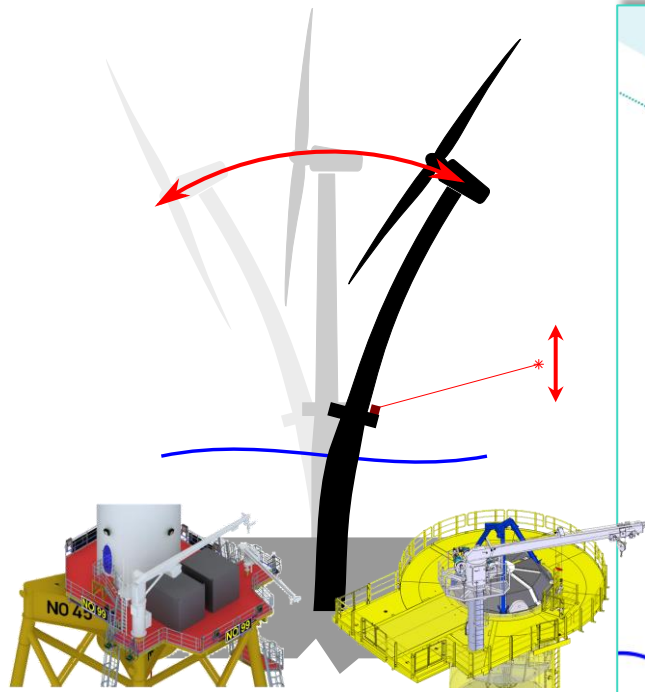



Sources of uncertainty & bias

Pointing accuracy & hard targeting

Drone deployed for inclination and motor offset calibrations in combination with weekly turbine structure hard targeting

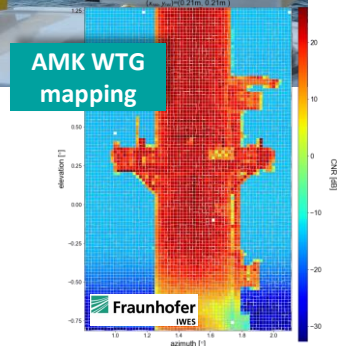
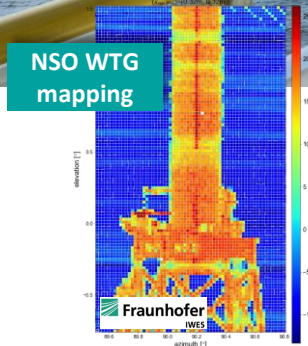
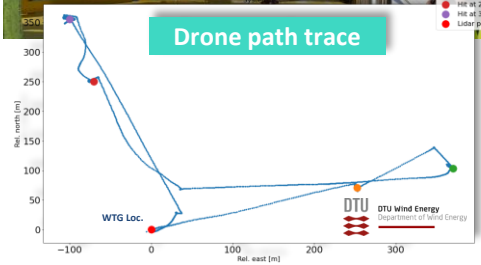
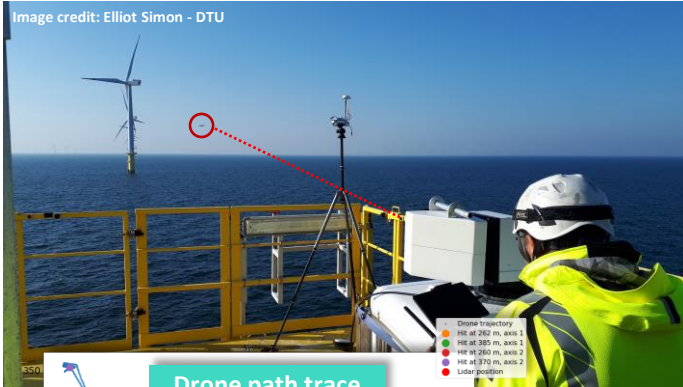



Sources of uncertainty & bias

Inter-device biases

LiDARs deployed in a pre- and post-campaign inter-calibration to check and control for initial and developing radial WS biases

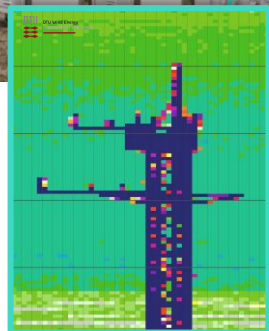
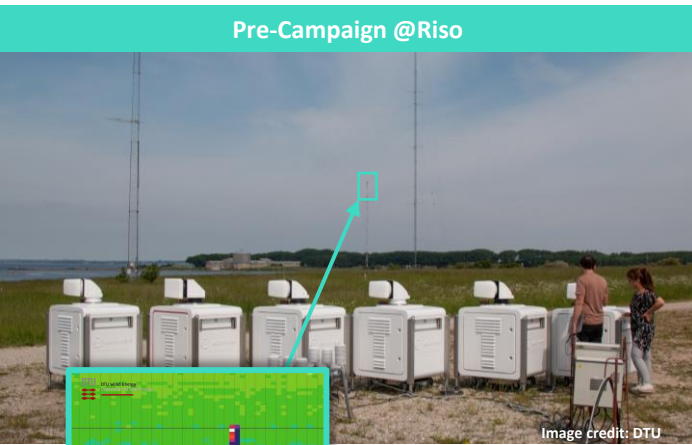

Tested at 1.0, 1.5, 2.0, 3.0 & 5.0km ranges

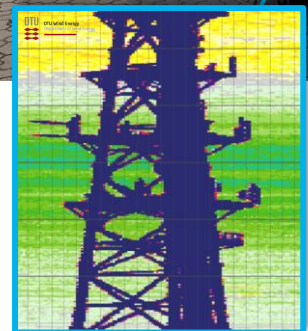
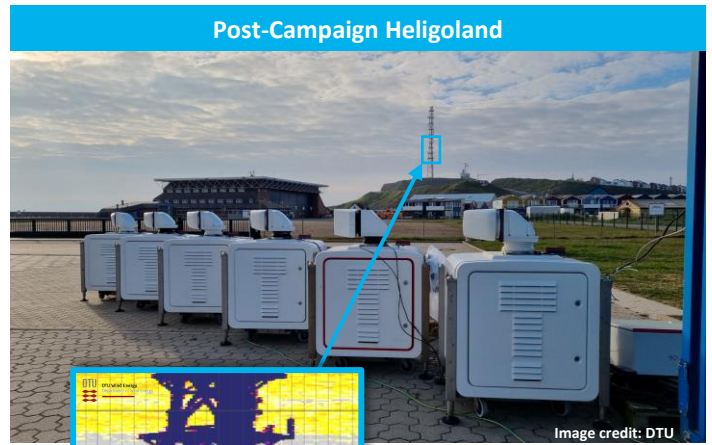

Elevations the same in both cases, LiDAR beams parallel



Sources of uncertainty & bias

Spatial variations and neighboring wind farms

Spatial gradients bias blockage measurements

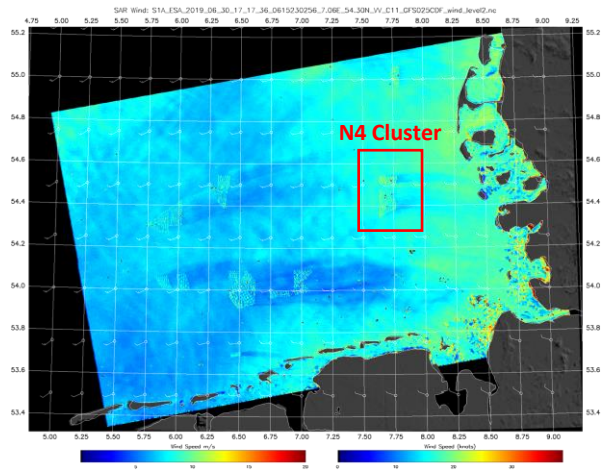

DTU Technical University of Denmark
Processed of DTU Wind Energy 2019 Jul 09 10:53:49 UTC

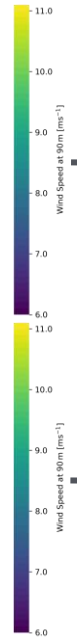
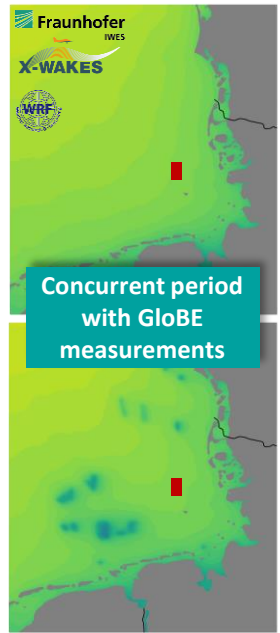

WRF unwaked spatial gradient correction

WRF waked spatial gradient correction

Statistical-based correction to blockage dual Doppler wind speeds



Sources of uncertainty & bias

Time sync for dual-Doppler

All measurement devices placed on common network and wind farm NTP server for consistent logging, monitoring and time synchronisation

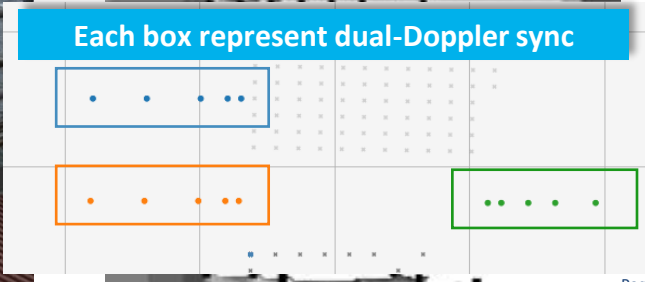
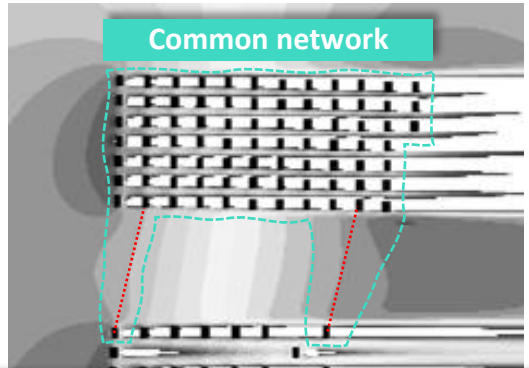
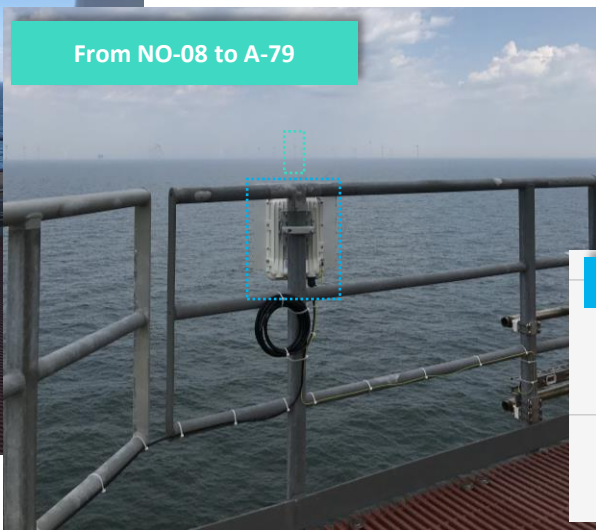
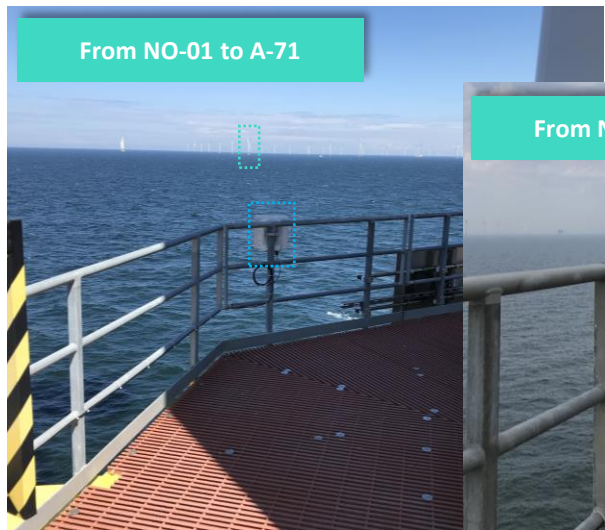



Site characterisation

Wind distributions

Preliminary

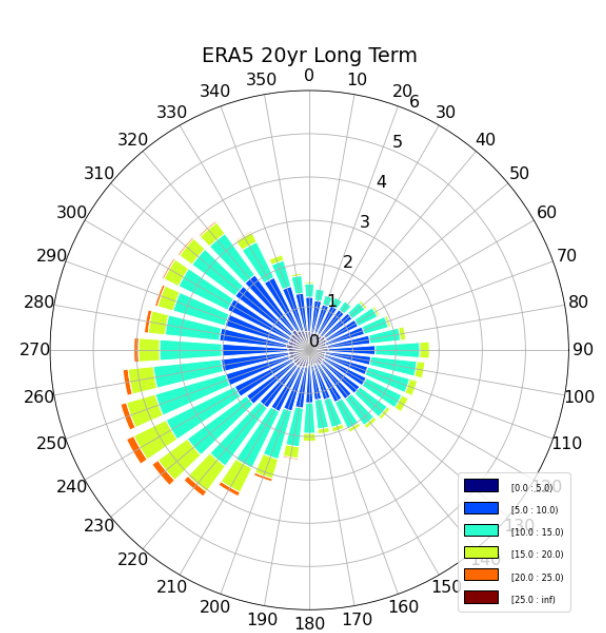
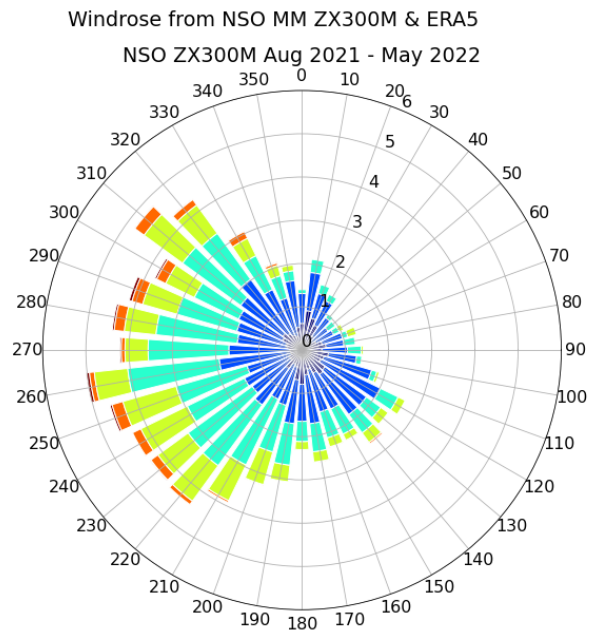
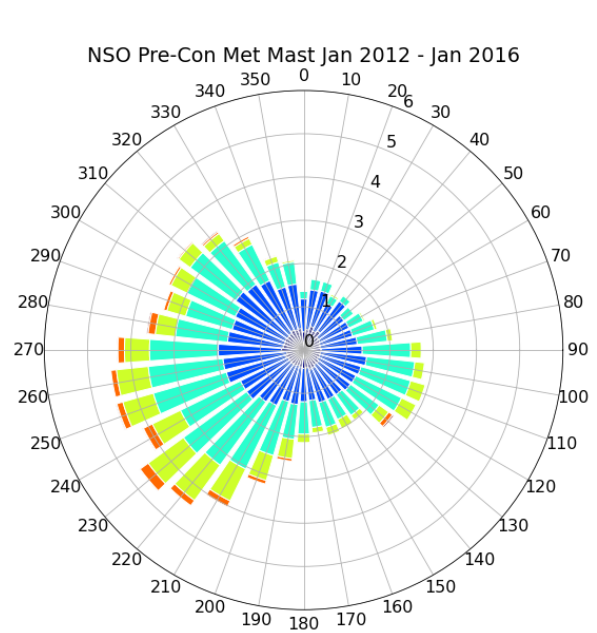



Site characterisation

Stability distribution from NSO met mast

Preliminary

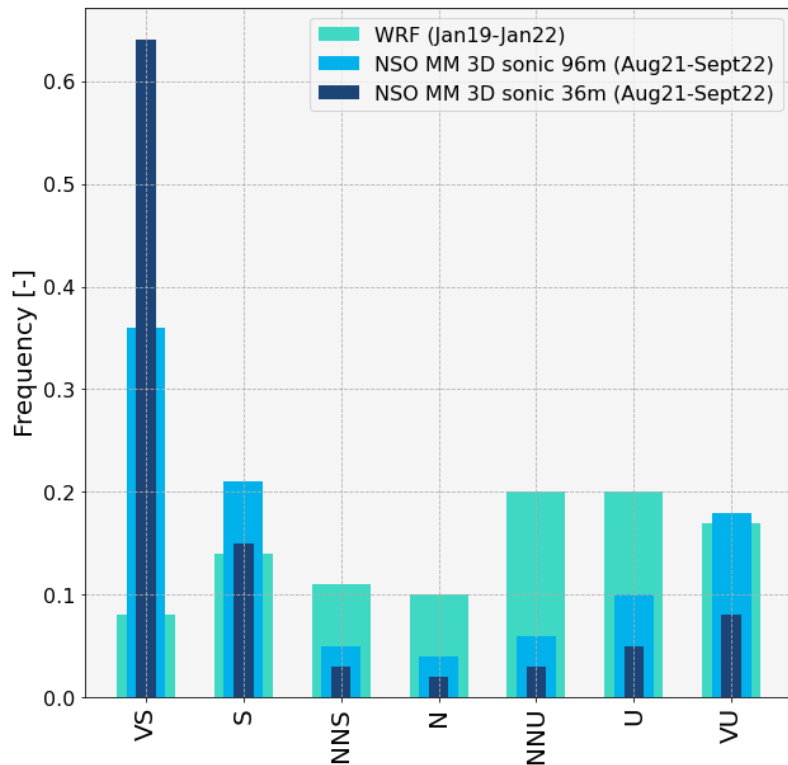

Classification	MOL Range*
Very stable (VS)	10 < L < 50
Stable (S)	50 < L < 200
Near neutral stable (NNS)	200 < L < 500
Neutral (N)	L > 500
Near neutral unstable (NNU)	-500 < L < -200
Unstable (U)	-200 < L < -100
Very unstable (VU)	-100 < L < -50

*OL classification ranges likely not appropriate for WRF, however shown for consistency.

**OL calculated directly using 3D ultrasonic anemometers at each height at 16Hz and down-sampled.



Example LiDAR measurement

Impact of corrections on beam elevations

Preliminary



Desired points in z @6.5km

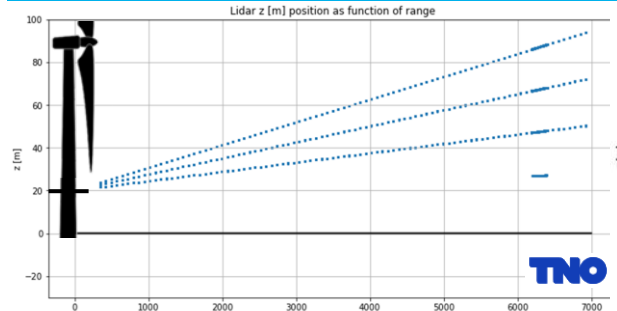

Inc. Tilt Motions @6.5km

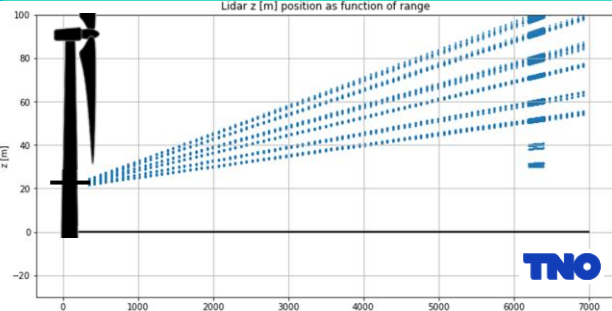

Inc. Drone Inc Offsets @6.5km

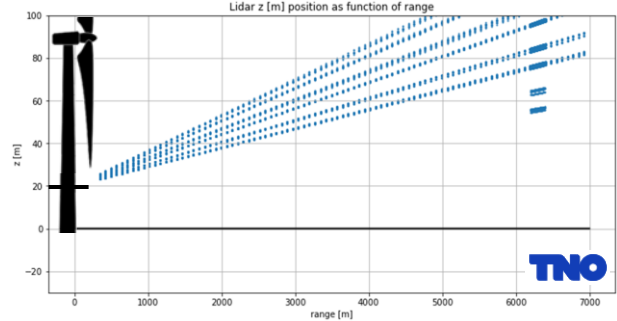

Inc. Drone Motor Offsets @6.5km

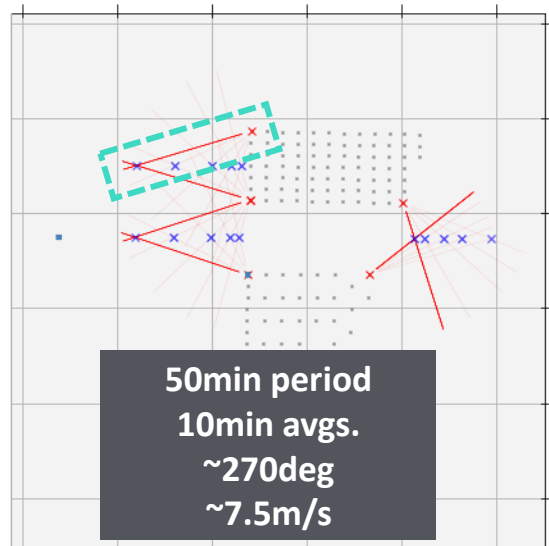
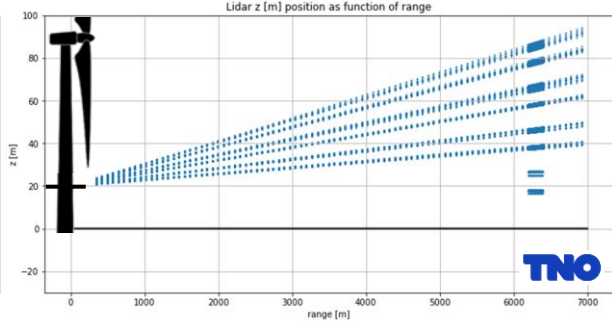



Example LiDAR measurement

Impact of turbine motion shearing

Preliminary



Radial wind speed measurements interpolation | Time window analysis from 2021-10-16, 14:10:00 to 2021-10-16, 14:20:00 V3

GLOBE 5 radial wind speed interpolation for dual doppler reconstruction

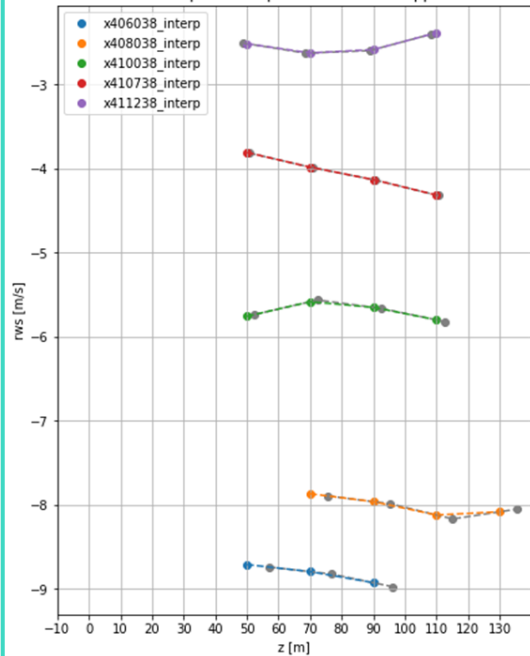

GLOBE 6 radial wind speed interpolation for dual doppler reconstruction

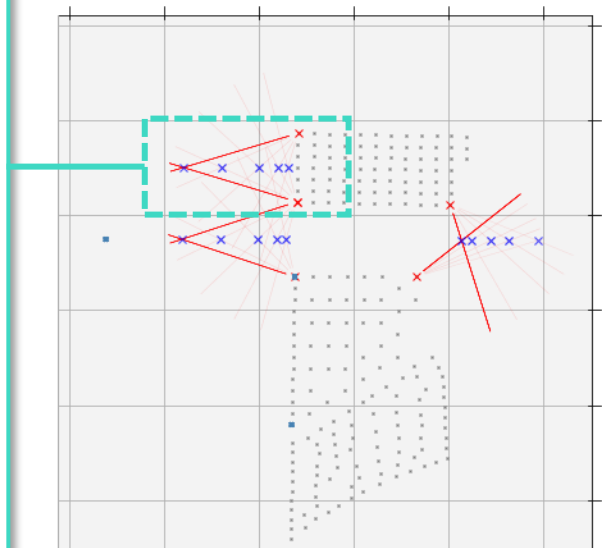
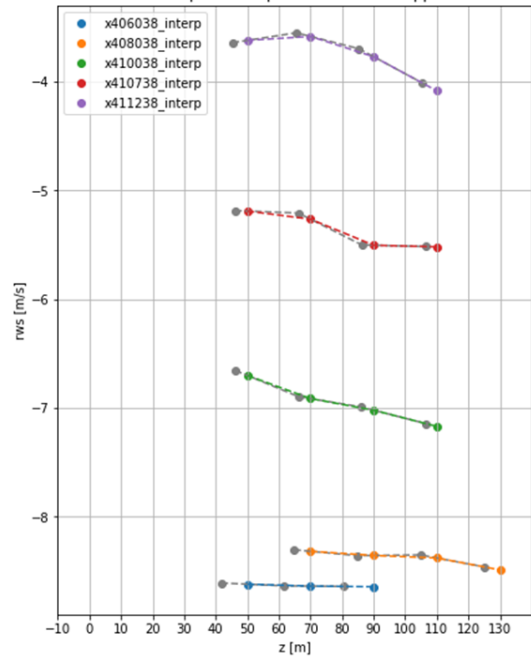

Preliminary



Atmospheric boundary layer (ABL) height

Measured vs modelled

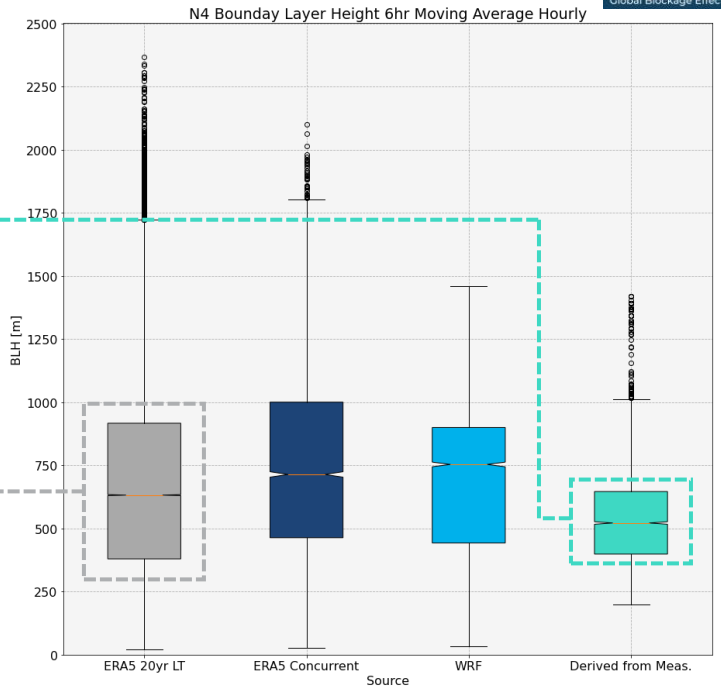
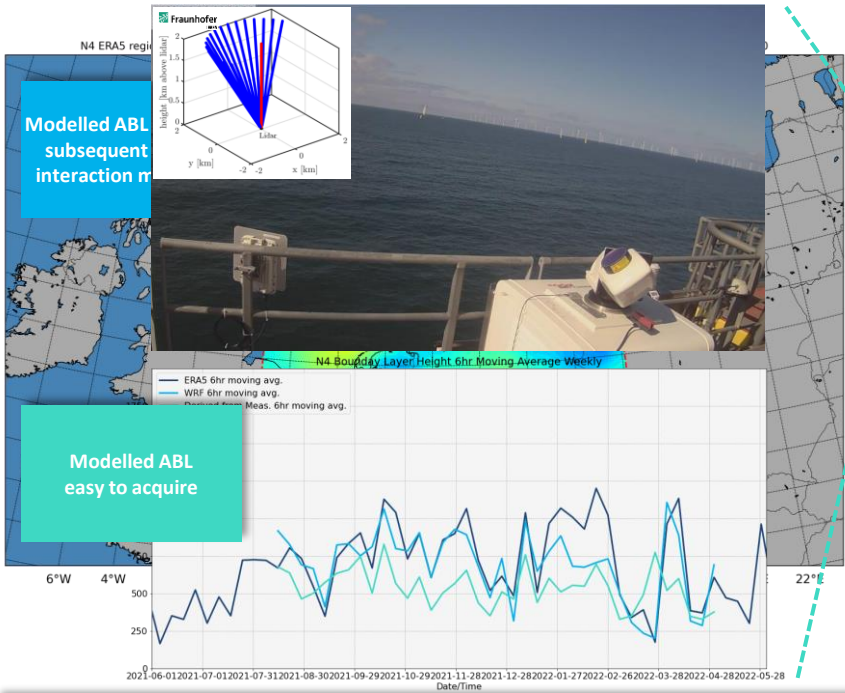

Systematic biases exist between ABL from models vs derived from measurement

Boundary layer height definitions			
RI < 0.25	RI < 0.25	TKE < 1E-6 m ² s ⁻² *	Vertical perturb. & CNR



Thinking to the future

Plan until project end

- Additional hard targeting work package undertakes to increase confidence in elevation offsets → Using weekly hard targeting
- GloBE completion end of November 2023
- Until then:
 - Continue model comparison against SCADA and wind measurements
 - Generate common understanding on GBE definitions
 - Disseminate findings to industry

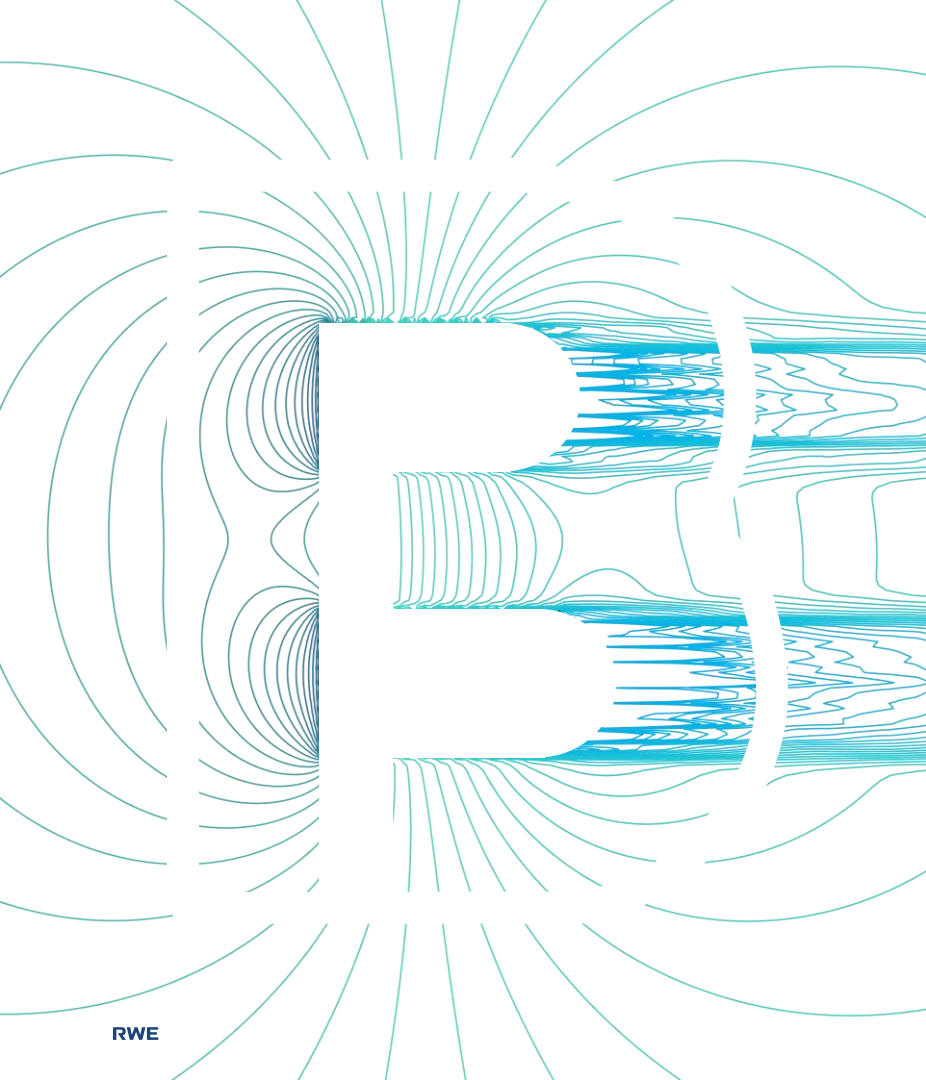

RWE | GLOBE

Global Blockage Effect



Background & motivation



GLOBE experimental design



Questions



RWE | GLOBE
Global Blockage Effect

Prepared by:



Christopher Rodaway
christopher.rodaway@rwe.com



Kester Gunn
kester.gunn@rwe.com



Sam Williams
sam.williams@rwe.com



Alessandro Sebastiani
slessandro.sebastiani@rwe.com

RWE | GLOBE
Global Blockage Effect

Special acknowledgments:



Mike Courtney
Elliot Simon
Gunhild Thorsen
Emilie Clausen



Julia Gottschall
Martin Dörenkämper
Pedro Santos
Erik Patschke
Lukas Vollmer
Lin-Ya Hung



Jan-Willem Wagenaar
Nassir Cassamo
Marco Turrini
Dennis Wouters
Yichao Liu

RWE | GLOBE

Global Blockage Effect

Made possible by:

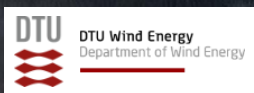

Supported by:



Federal Ministry
for Economic Affairs
and Climate Action

on the basis of a decision
by the German Bundestag

Computing resources were partly provided by
the North-German Supercomputing Alliance
(HLRN).



Ministerie van Economische Zaken
en Klimaat

This project is co-financed by TKI-Energy from the "Toeslag
voor Exponentoria voor Kennis en Innovatie (TKI)" from
the Ministry of Economic Affairs and Climate

Agenda



Chris Rodaway,
RWE Offshore Wind

Blockage: Background, Motivation and State of the Art



Chris Rodaway,
RWE Offshore Wind

Measurement Campaign Experimental Design



Dr Elliot Simon,
DTU Wind Energy

Mitigating Bias and Uncertainty in Offshore Wind LiDAR
Measurement Campaigns



Dr Julia Gottschall
Fraunhofer IWES

Verification of Offshore Scanning LiDAR Measurements using a
Floating Wind LiDAR System: the OWA-GloBE Case Study



Dr Graham Hawkes,
Frazer-Nash Consultancy

Rapid Blockage Model Development and Validation



Neil Adams,
Carbon Trust

Towards Industry Consensus on the Global Blockage Effect

OWA GloBE: Mitigating bias and uncertainty in offshore wind lidar measurement campaigns

Elliot Simon, Mike Courtney, Gunhild Thorsen, Chris Rodaway,
Kester Gunn, Neil Adams
ellsim@dtu.dk

DTU Wind & Energy Systems
Measurement Systems and Methods

24 May, 2023

A few words on uncertainties

- All measurements are uncertain
- Good measurements are delivered with uncertainty estimates and should be examined under this context
- **Statistical uncertainty:** Scatter caused by fluctuations in random variables, dependent on sample size
- **Systematic uncertainty (bias):** Constant, non-random, unknown error independent of sample size
- The higher the complexity and accuracy required in your measurements, the more meticulous you must be in understanding and mitigating the sources of uncertainty

Lidar uncertainty sources in GloBE

- The expected magnitude of wind-farm blockage is very small and thus difficult to measure
 - CFD simulations indicate a range of 0.5-6% in relative wind speed deviations
- Uncertainties must be sufficiently small to be able to form conclusions
- Before committing, uncertainty modelling was performed to assess feasibility in achieving the measurement goals. This was repeated following the results from onshore work

- The main uncertainty components of a scanning lidar system can be grouped into two categories: **Beam positioning** and **measurement quantification**
- **Beam positioning**
 - The flexibility of a moveable scan head is also a weakness
 - The motion of the platform (i.e. lidar) must be compensated for
 - Elevation axis errors are the most critical to minimize
 - At 6 km range, a 0.1° elevation offset leads to 10.5 m height difference
- **Measurement quantification**
 - The (6) lidar systems must function correctly and consistently when used together
 - Onshore calibration exercises provide hard evidence of equipment failures and a means for applying corrections when needed

Lidar measurement quantification

- **Uncertainty sources identified**

- Measured line-of-sight (LOS) speeds
- Range gates (measurement distances)
- Alignment of optics
- Timestamp and time-zone consistency

- **Mitigation methods used**

- Onshore LOS speed intercalibrations (pre & post-campaign)
- Onshore ranging calibration
- Beam centering checks
- NTP time synchronization
- Monitoring of real-time data

Onshore LOS speed intercalibrations

- General procedure:
 - Install all lidars side-by-side in suitable geometry
 - Use hard target mapping to locate a common reference object (e.g. met-mast sensor)
 - Determine the respective angles to align beams in parallel
 - Set systems to measure fixed (staring) and gather concurrent independent observations
 - Filter dataset on CNR and wind direction
 - Analyze data by forming pairs between all combinations of the 6 lidars and performing linear regression
 - Determine offsets and relative uncertainty estimate

Pre-campaign at Risø

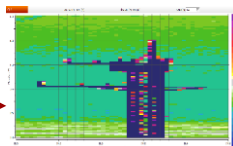
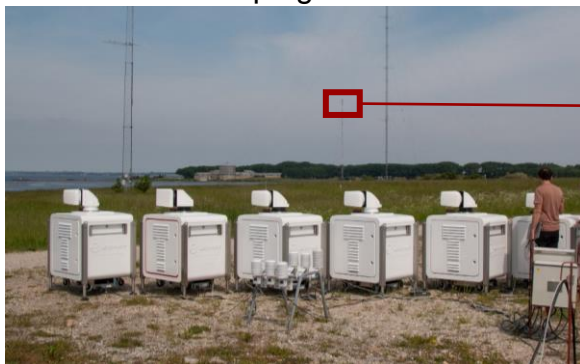

Post-campaign on Helgoland

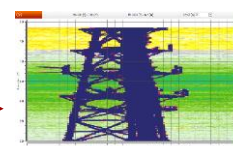

LOS speed intercalibration results

- Regression coefficients and scatterplots provide indication of consistent functionality between lidars and expose potential issues
- Two systems have experienced hardware malfunctions during the campaign. This was later tested and verified by the manufacturer
- Further investigation led to the determination of the failure event and allowed correction terms to be applied
- These failures would likely not have been discovered otherwise

Pre-campaign coefficients

Lidar #	2	4	5	6	7
1	0.997	0.9947	0.9932	0.9966	0.9942
2		0.9976	0.9961	0.9996	0.9971
4			0.9984	1.0019	0.9994
5				1.0034	1.001
6					0.9975

Post-campaign coefficients

Lidar #	2	4	5	6	7
1	1.0075	1.0178	1.0195	1.0192	1.0194
2		1.0103	1.0119	1.0117	1.0119
4			1.0017	1.0014	1.0016
5				0.9997	0.9999
6					1.0002

Test method	Lidar #1 offset	Lidar #2 offset
DTU field intercalibration	0.11 m/s	0.064 m/s
Vaisala lab bench test	0.13 m/s	0.082 m/s

Scatterplot matrix, pre-campaign

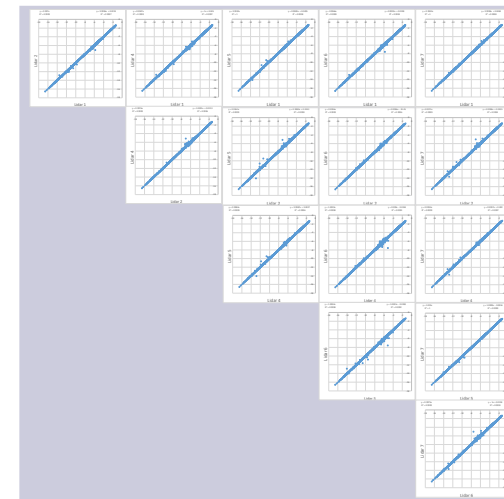

Lidar beam positioning

- **Uncertainty sources identified**
 - Azimuth orientation
 - Earth curvature
 - Beam elevation and dual-Doppler crossing angles
 - Dual-Doppler synchronization
 - Scan head backlash
 - Levelling and elevation motor offsets
 - Platform tilt motion

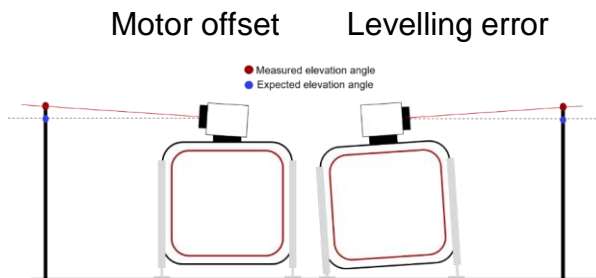

- **Mitigation methods used**
 - System alignment
 - Hard target mapping
 - Sea surface levelling
 - Drone pointing calibration
 - Trajectory optimization
 - Earth curvature correction
 - Lidar positioning and beam geometry
 - Pre-move anti-backlash points
 - Coordinated multi-lidar scan schedule
 - Motion measurements
 - Extra motion sensors installed
 - Onshore zero-tilt inclinometer calibration
 - Onshore testing and development of a motion (tilt) correction method

Extra motion sensors installed

- Lidar i.e., transition piece (TP) motion is measured at 16 Hz using inclinometer and IMU sensors
- This data is used for tilt corrections and the drone pointing calibrations

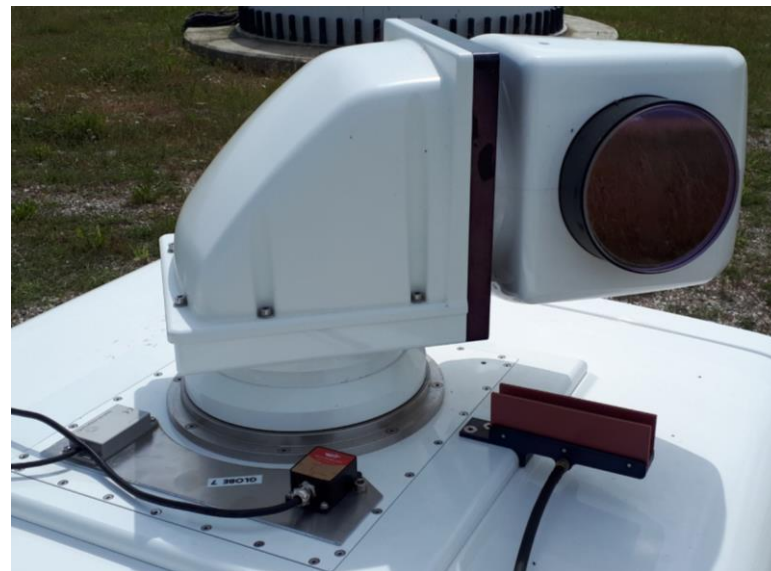
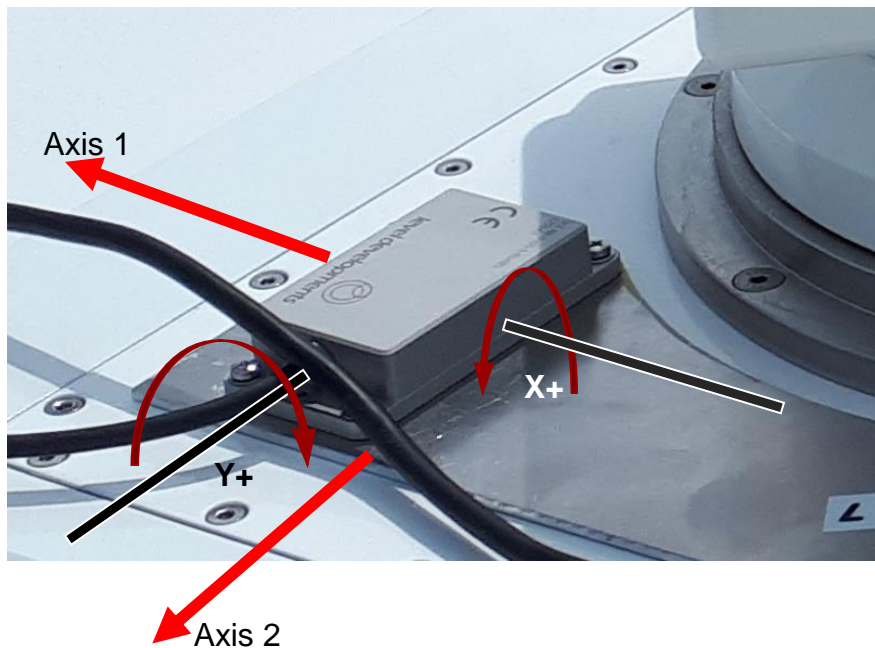

Turbine TP tilting

- The offshore platforms move due to turbine operation, windage, and ocean waves
- The foundation types and responses differ between wind farms (ABW = monopile, NSO = jacket)
- Before the campaign, tilt measurements were carried out on both turbine types
- Results indicate a (30s average) deflection range of: $\pm 0.1^\circ$ (NSO) and $\pm 0.2^\circ$ (ABW)

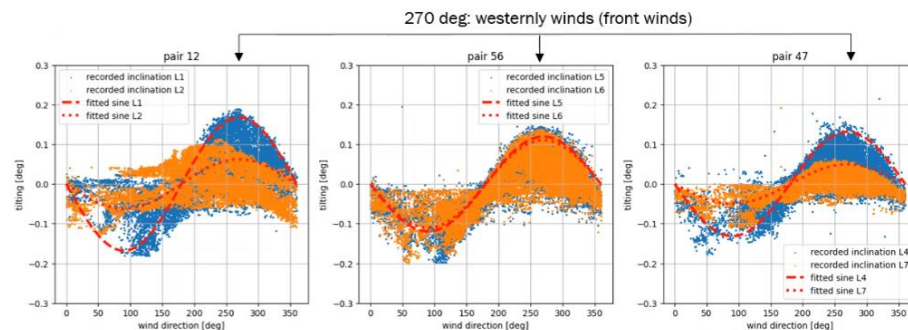
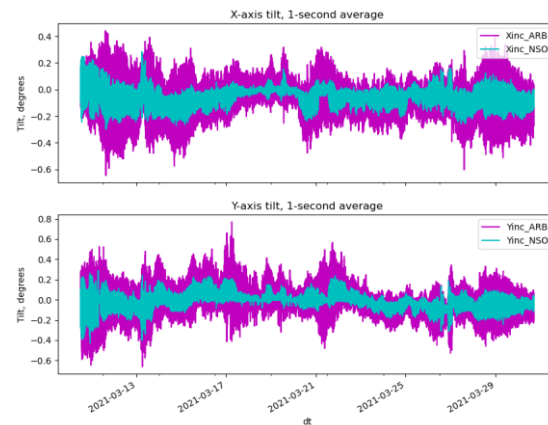

Source: Marco Turrini, TNO

Onshore tilt testing

- A tilting test rig was designed and built which can emulate the dynamic offshore tilting
- Onshore tilting experiments were performed to develop and test a method to correct the elevation errors
- Two lidars were installed side-by-side: one fixed and the other tilting to test various approaches

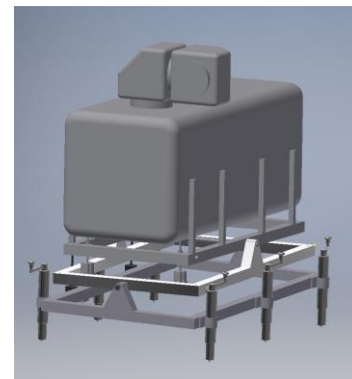
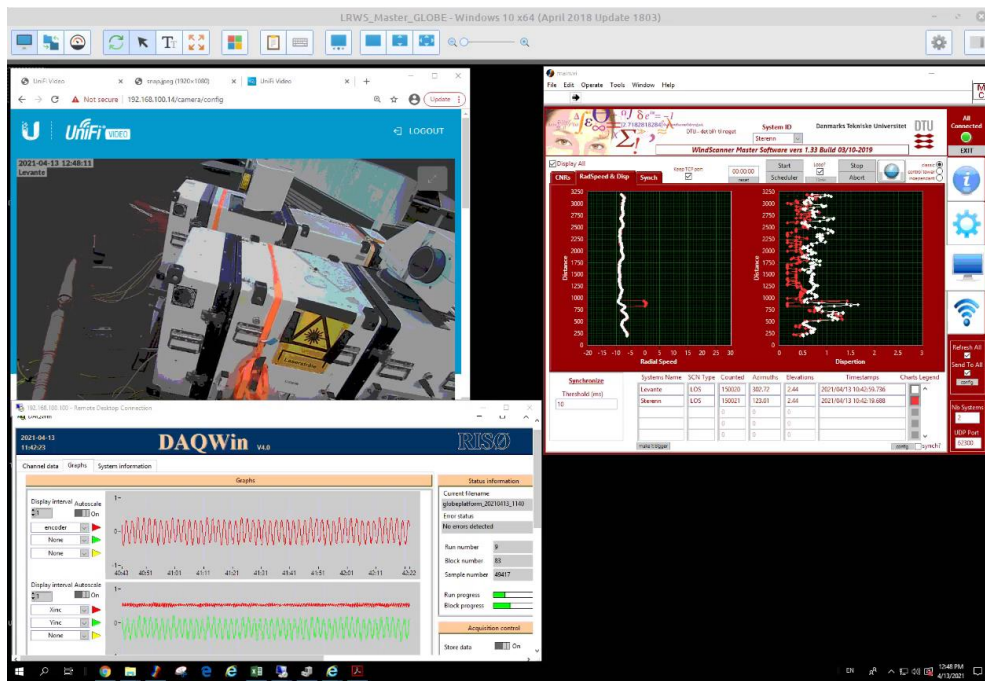

Drone based lidar pointing verification

- Hard targets are often unavailable near offshore measurement positions
- We have demonstrated a new method to verify a lidar's beam positioning using an aerial drone as a moveable hard-target
- The drone method produces (together with associated uncertainties):
 - Direct evidence of where the lidar is pointing
 - Levelling errors (pitch & roll)
 - Elevation motor offset
 - Azimuth misalignment

Drone equipment



Aligning drone with lidar beam



Drone offshore procedure

1. Measure scan head and RTK base station positions
2. Input position of RTK base station into RTK controller
3. Set lidar to LOS stare mode along pitch axis of lidar casing
4. Manual flight using scope, first to 250 then 350 meters. Verify drone was hit by lidar beam by monitoring CNR curve
5. Extract drone data and lidar data for analysis
6. Repeat #3-5 for roll axis and all other axes with clear visibility



Signal reflectivity vs. Time and Range

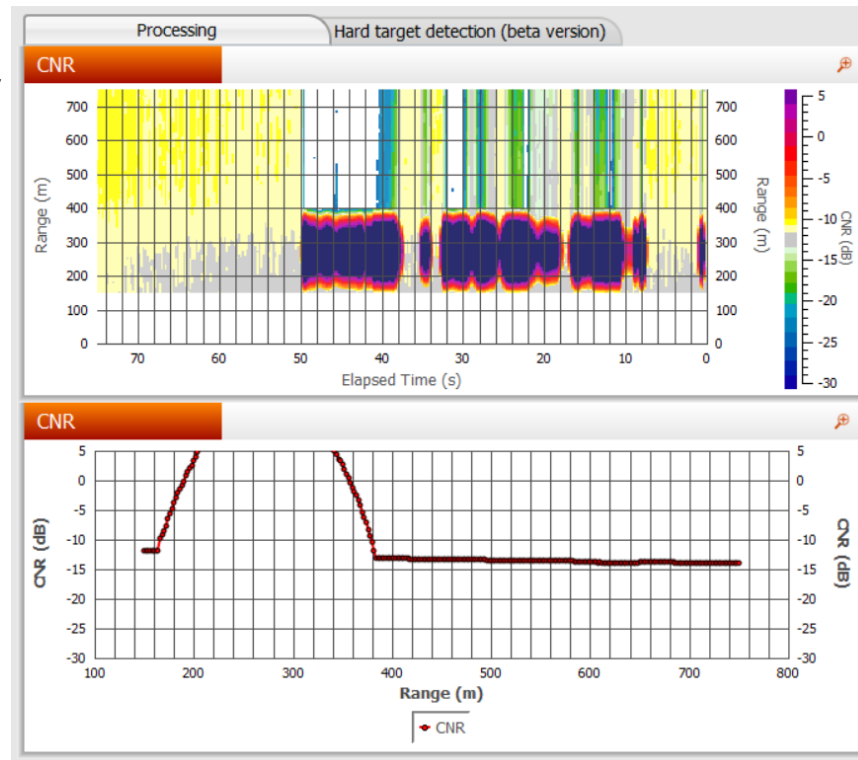

Final thoughts

- Following this, we have produced a comprehensive high-quality dataset with multiple redundant methods for performing cross-checks of the alignment and correct operation of the equipment
- Offshore measurement campaigns are expensive and often time-sensitive – i.e. very difficult to redo!
- Most campaigns won't require the level of extensive scrutiny needed in GloBE
- It is good practice to consider the main uncertainty sources in your use case and do your best to quantify and mitigate them



Thank you to colleagues from DTU, TNO, Fraunhofer, RWE, and the GloBE partners for contributing to this work

Agenda



Chris Rodaway,
RWE Offshore Wind

Blockage: Background, Motivation and State of the Art



Chris Rodaway,
RWE Offshore Wind

Measurement Campaign Experimental Design



Dr Elliot Simon,
DTU Wind Energy

Mitigating Bias and Uncertainty in Offshore Wind LiDAR
Measurement Campaigns



Dr Julia Gottschall
Fraunhofer IWES

Verification of Offshore Scanning LiDAR Measurements using a
Floating Wind LiDAR System: the OWA-GloBE Case Study



Dr Graham Hawkes,
Frazer-Nash Consultancy

Rapid Blockage Model Development and Validation



Neil Adams,
Carbon Trust

Towards Industry Consensus on the Global Blockage Effect

A photograph of an offshore wind farm with several white wind turbines on yellow jackets in the ocean under a clear blue sky.

24-05-2023 / WESC 2023 – Mini-symposium 2.1 (GloBE)

Verification of offshore scanning lidar measurements using a floating wind lidar system: the OWA-GloBE case study

Pedro Santos, Lin-Ya Hung, [Julia Gottschall](#) (Fraunhofer IWES)

Nassir Cassamo, Marco Turrini, Jan Willem Wagenaar (TNO); Elliot Simon, Mike Courtney, Gunhild Thorsen (DTU); Christopher Rodaway (RWE)

© Fraunhofer IWES/Gerrit Wolken-Möhlmann

Supported by:



on the basis of a decision
by the German Bundestag

Overview

... of this presentation

- Introduction
- FLS measurement within GloBE
- Dual-Doppler points vs. FLS
 - @ position A (co-located)
 - @ position B (2-4 km distance)
- Conclusions

Introduction

- Scanning lidars are increasingly used in offshore application
- In the absence of a reference, the validation of such offshore scanning lidar measurements is a challenge
- Here: verification of offshore Dual-Doppler scanning lidar (DSL) wind speed measurements against a floating lidar system (FLS)

FLS measurements within GloBE

Two measurement positions

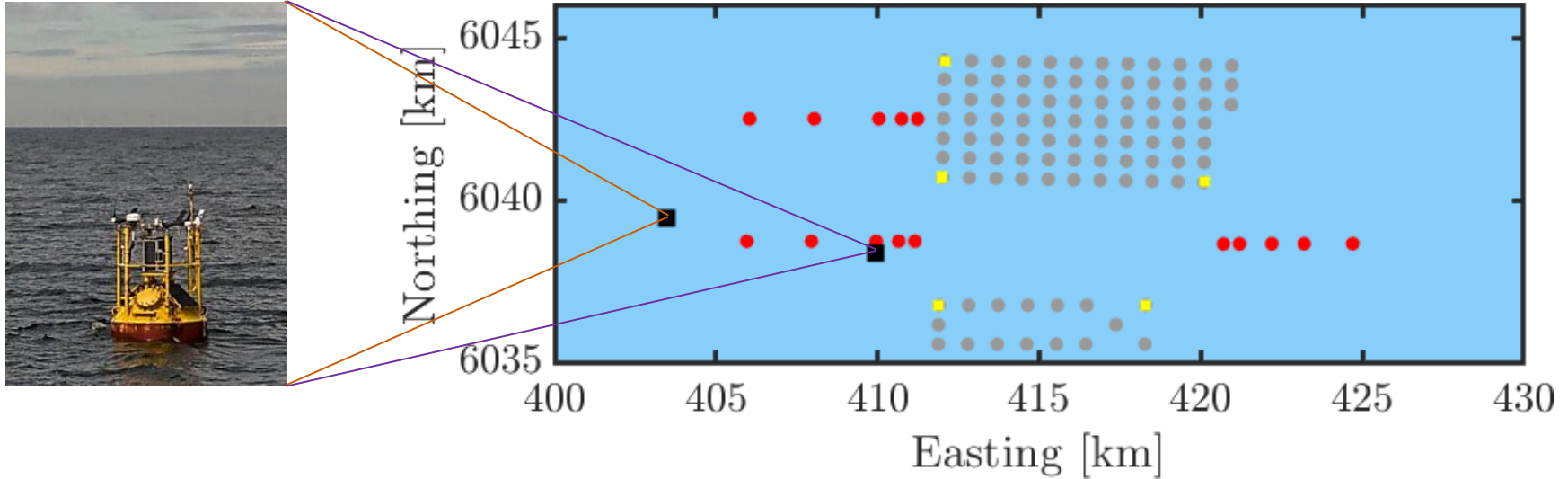

FLS measurements within GloBE

FLS as reference for DSL (?)

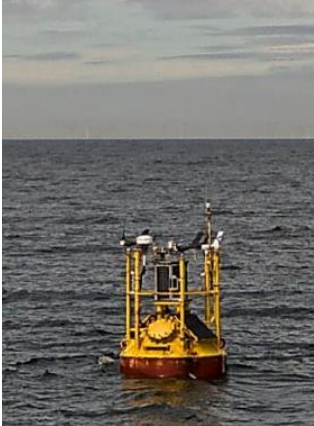

(example verification)

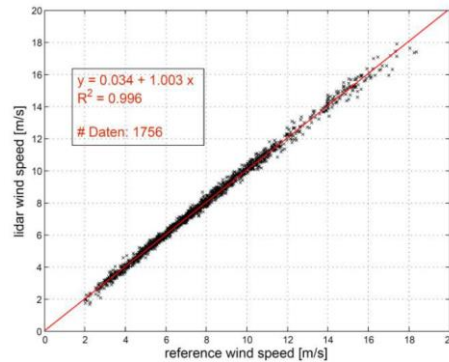

- FLS 10-min measurement data typically show good agreement with met mast reference, i.e., motion impact can be effectively compensated for
 - FLS and DSL may show different sensitivities (if any)
- Use this comparison to validate methodology to compensate SL tilt caused by transition piece movement

Dual-Doppler points vs. FLS@A and FLS@B

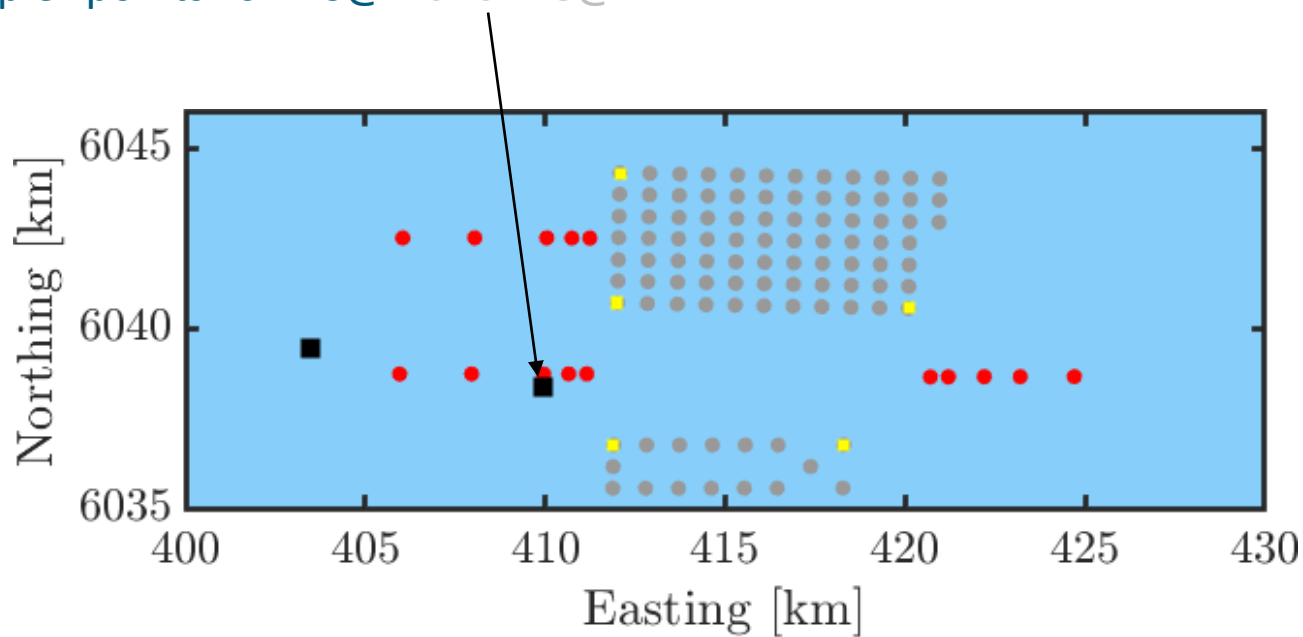

- For a 2-month period (17.09.2021 to 15.11.2021), FLS installed in co-located position to DSL measurement point located 2 km upstream (westerly) of Kaskasi gap

FLS@A vs. Dual-Doppler scanning lidar upstream Kaskasi

FLS@A vs. DD12 (Globe 1 + Globe 2, third reconstruction point) at 90 MASL

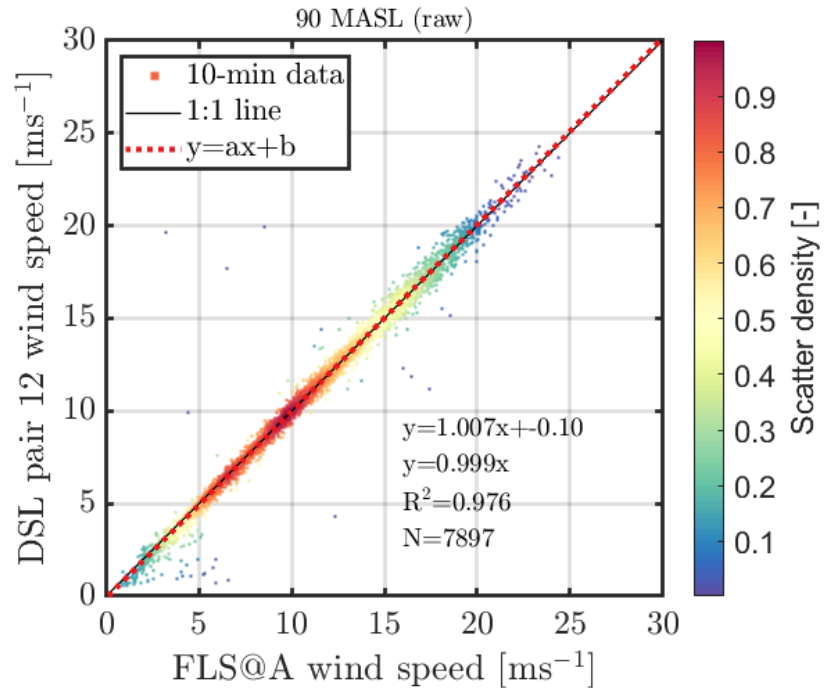

FLS@A vs. Dual-Doppler scanning lidar upstream Kaskasi

FLS@A vs. DD12 (Globe 1 + Globe 2, third reconstruction point) at 90 MASL

Raw DSL vs. Tilt-corrected DSL >> All wind directions

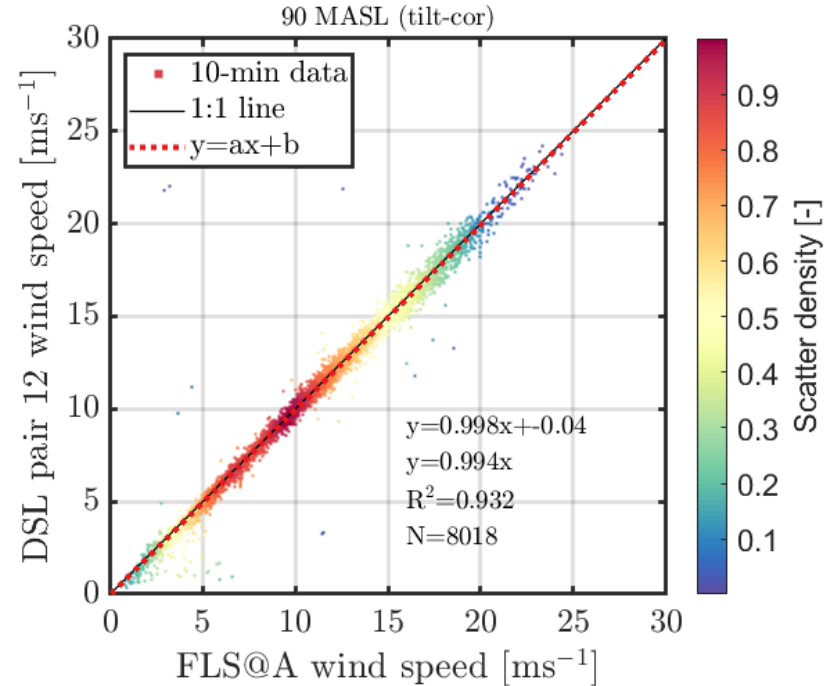
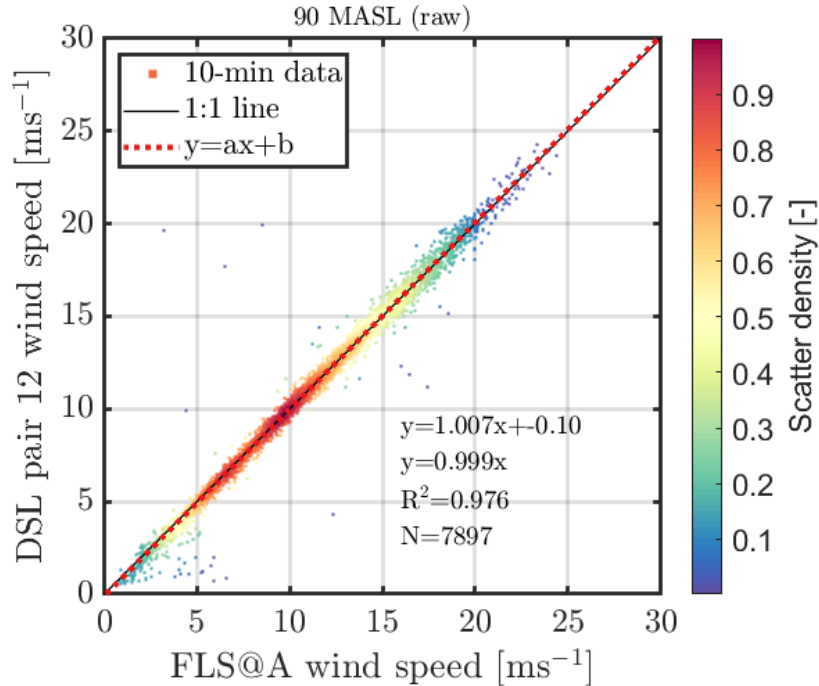

FLS@A vs. Dual-Doppler scanning lidar upstream Kaskasi

FLS@A vs. DD12 (Globe 1 + Globe 2, third reconstruction point) at 90 MASL

Raw DSL vs. Tilt-corrected DSL >> Westerlies [220 deg, 340 deg] for WS>5 m/s

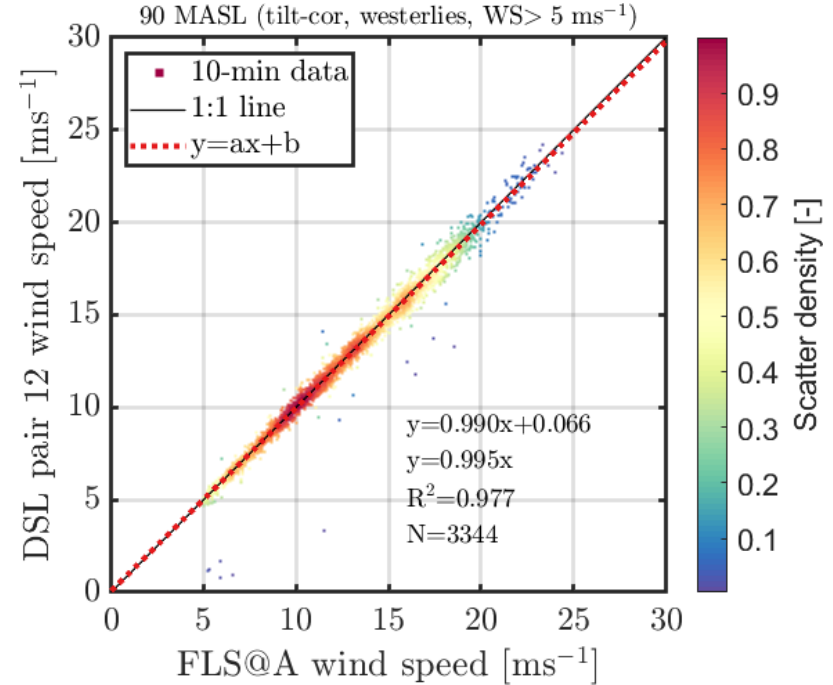
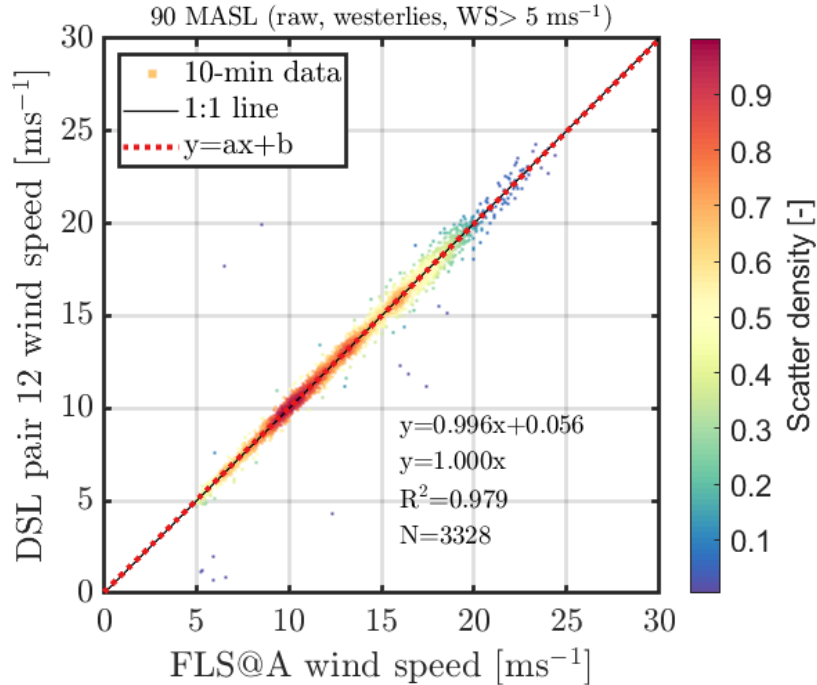

FLS@A vs. Dual-Doppler scanning lidar upstream Kaskasi

FLS@A vs. DD12 (Globe 1 + Globe 2, third reconstruction point) at 90 MASL

Tilt-corrected DSL vs. Tilt-corrected & pre-calibration offset DSL >> Westerlies [220 deg, 340 deg] for WS>5 m/s

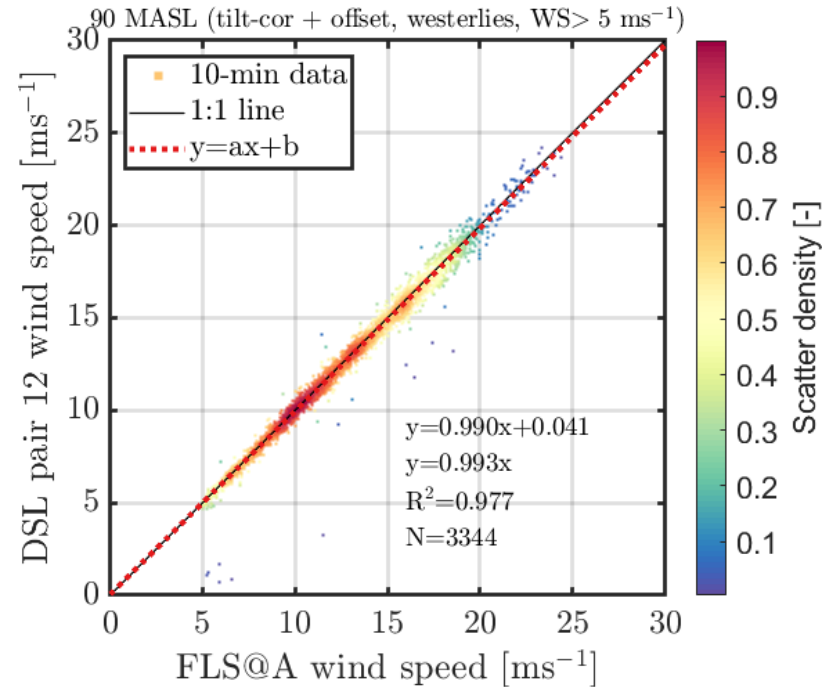
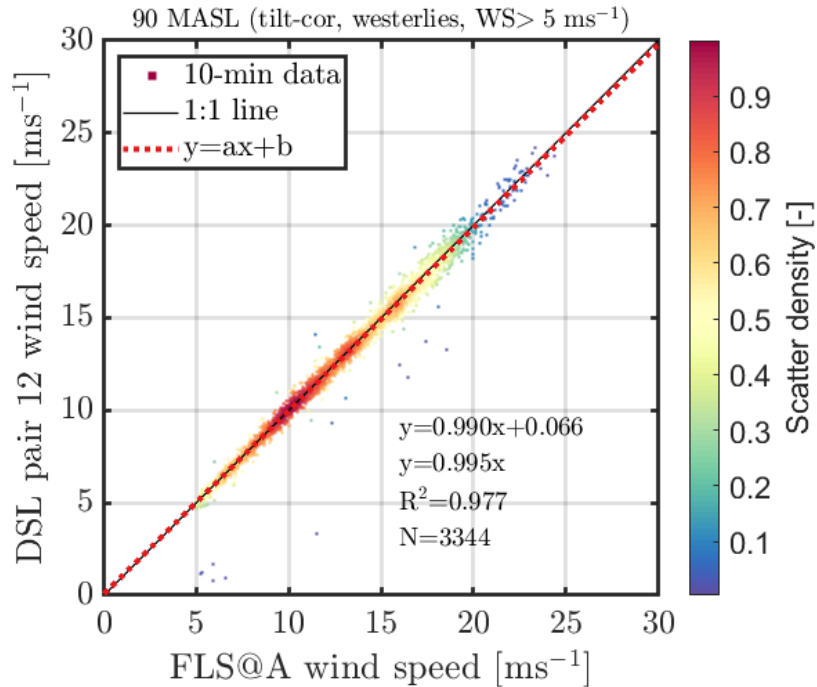

FLS@A vs. Dual-Doppler scanning lidar upstream Kaskasi

FLS@A vs. DD12 (Globe 1 + Globe 2, third reconstruction point) at 90 MASL

Tilt-corrected DSL vs. Tilt-corrected & pre-calibration offset & drone DSL >> Westerlies [220 deg, 340 deg] for WS>5 m/s

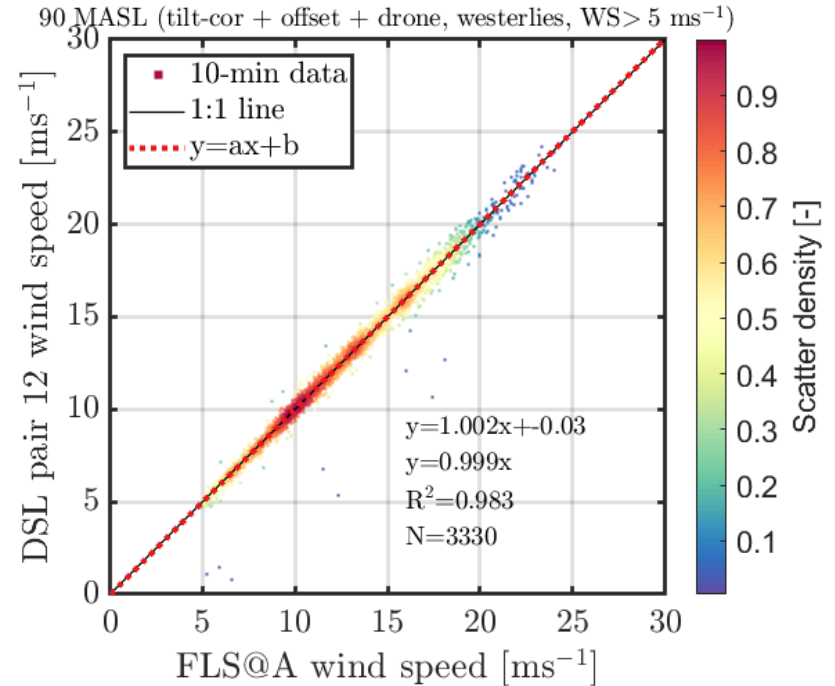
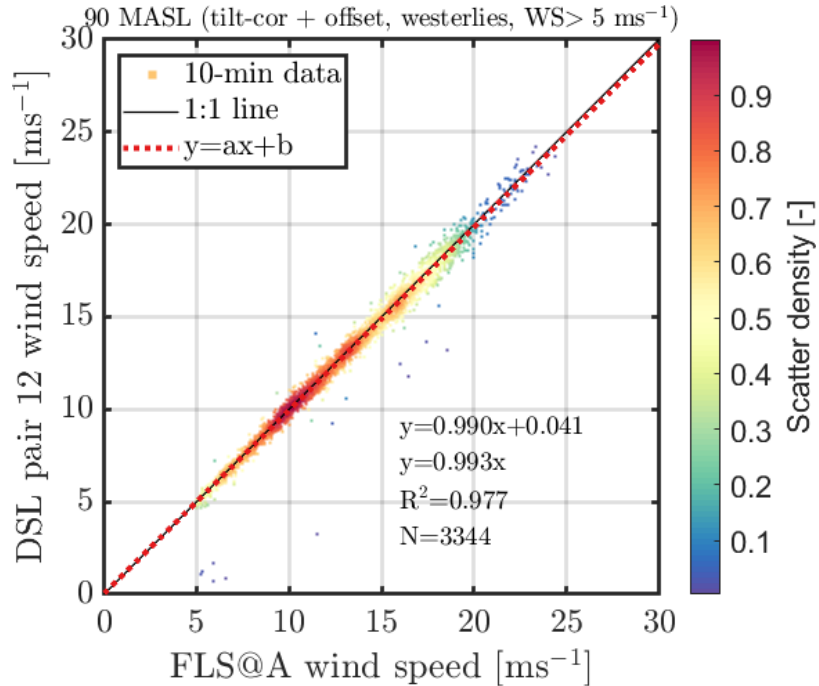

FLS@A vs. Dual-Doppler scanning lidar upstream Kaskasi

FLS@A vs. DD12 (Globe 1 + Globe 2, third reconstruction point) at 90 MASL

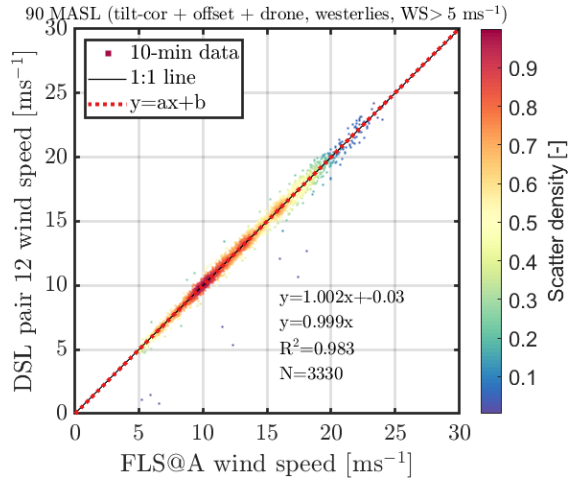

- **Preliminary result:**
addition of drone offset has largest (positive) impact on results

FLS@B compared with DD12

NOT co-located comparison! Distance between FLS@B and DD12 is 2.57 km

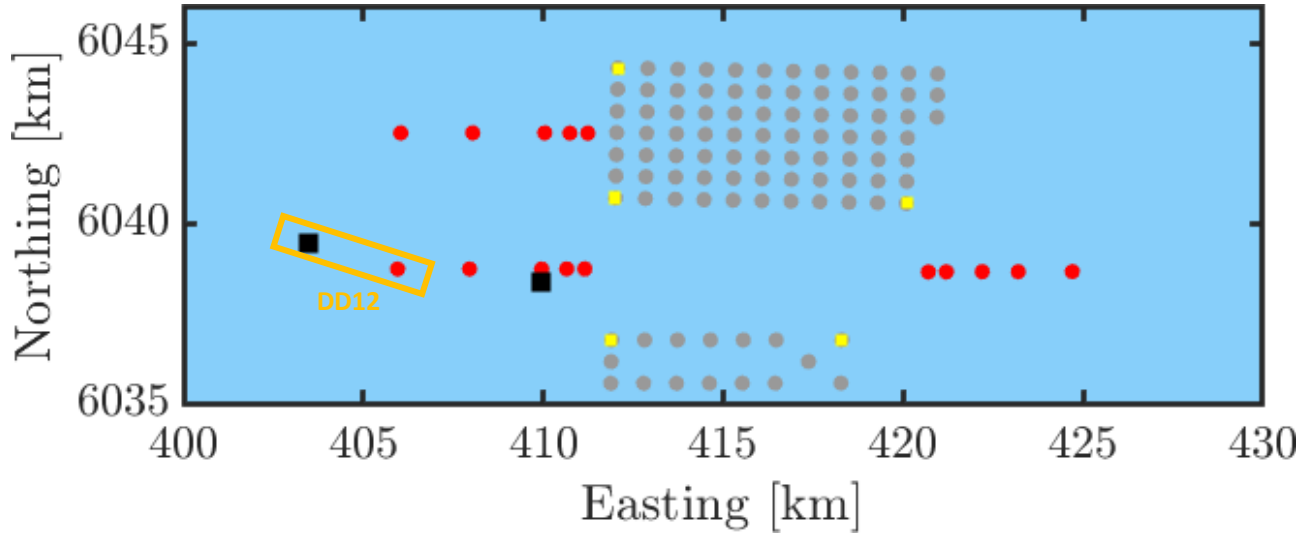

FLS@B vs. Dual-Doppler scanning lidar upstream Kaskasi

FLS@B vs. DD12 (Globe 1 + Globe 2, furthest reconstruction point) at 90 MASL

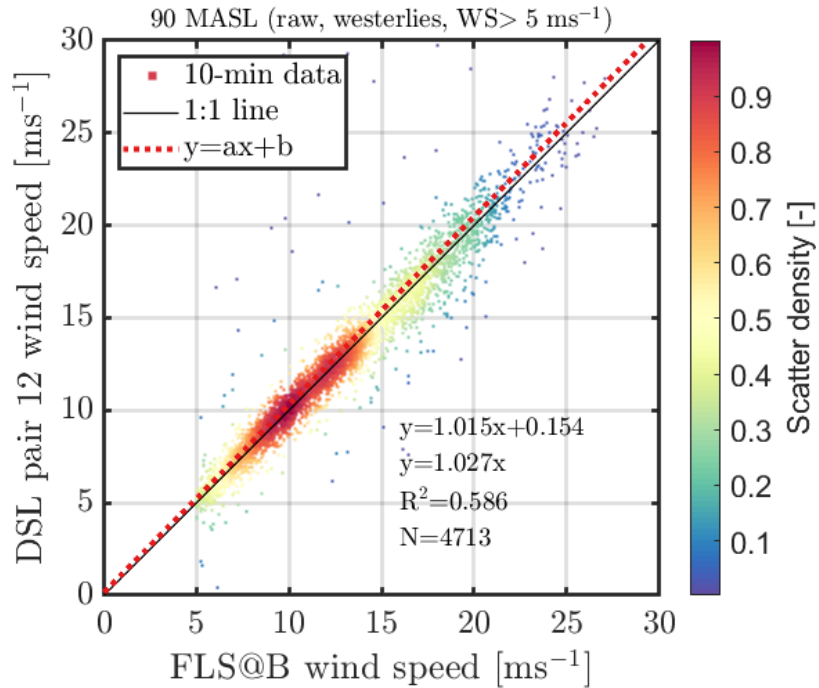

FLS@B vs. Dual-Doppler scanning lidar upstream Kaskasi

FLS@B vs. DD12 (Globe 1 + Globe 2, furthest reconstruction point) at 90 MASL

Raw DSL vs. Tilt-corrected DSL >> Westerlies [220 deg, 340 deg] for WS>5 m/s

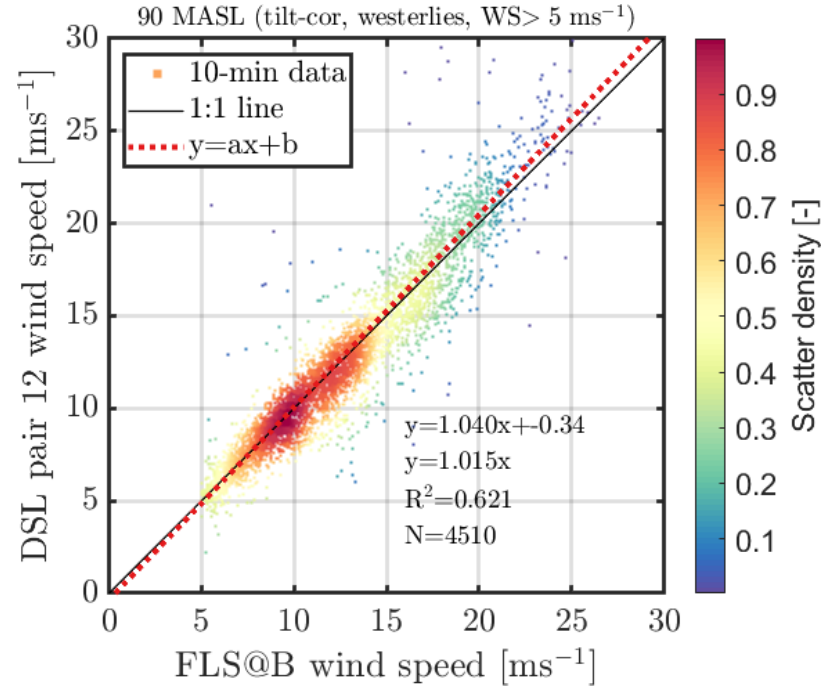
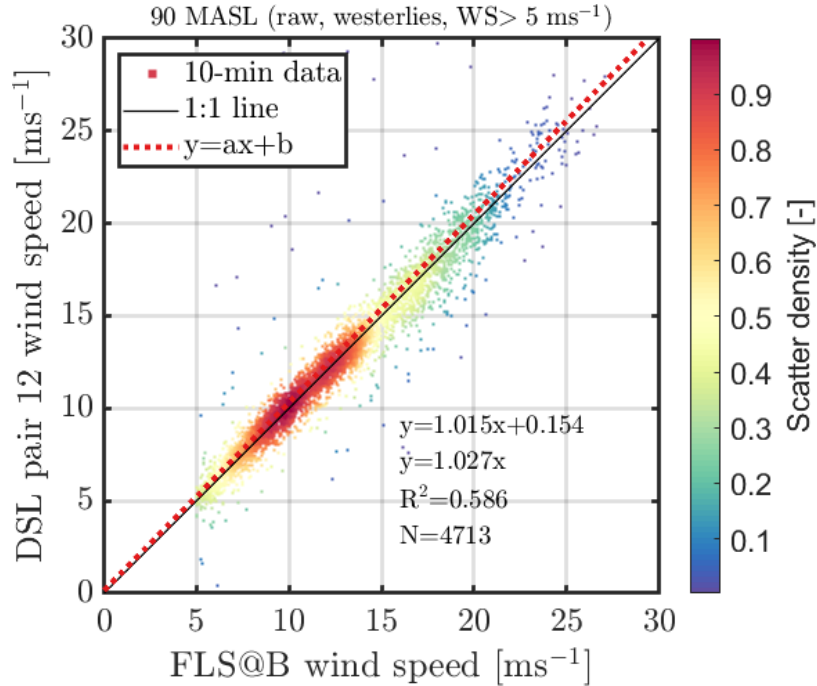

FLS@B vs. Dual-Doppler scanning lidar upstream Kaskasi

FLS@B vs. DD12 (Globe 1 + Globe 2, furthest reconstruction point) at 90 MASL

Tilt-corrected DSL vs. Tilt-corrected & pre-calibration offset DSL >>> Westerlies [220 deg, 340 deg] for WS>5 m/s

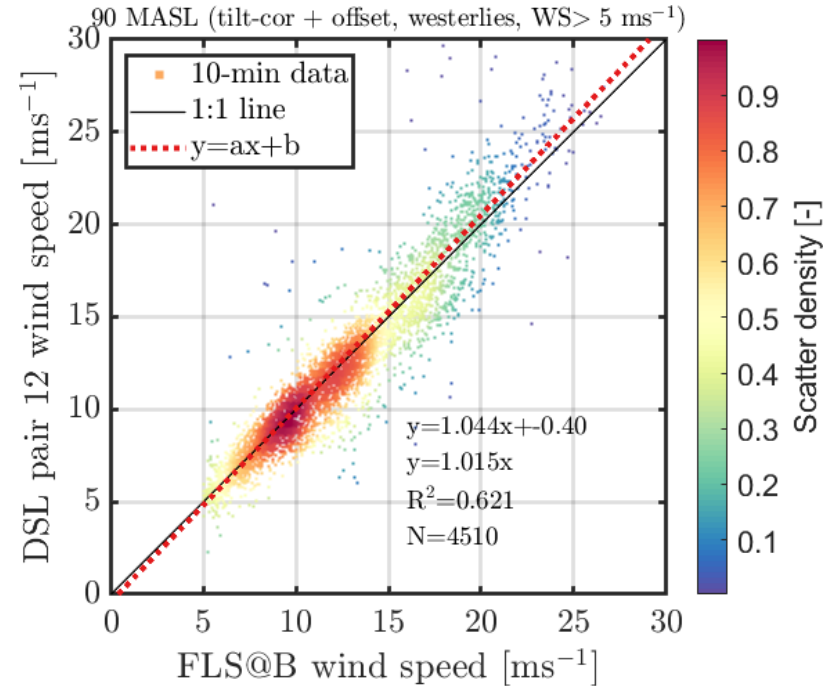
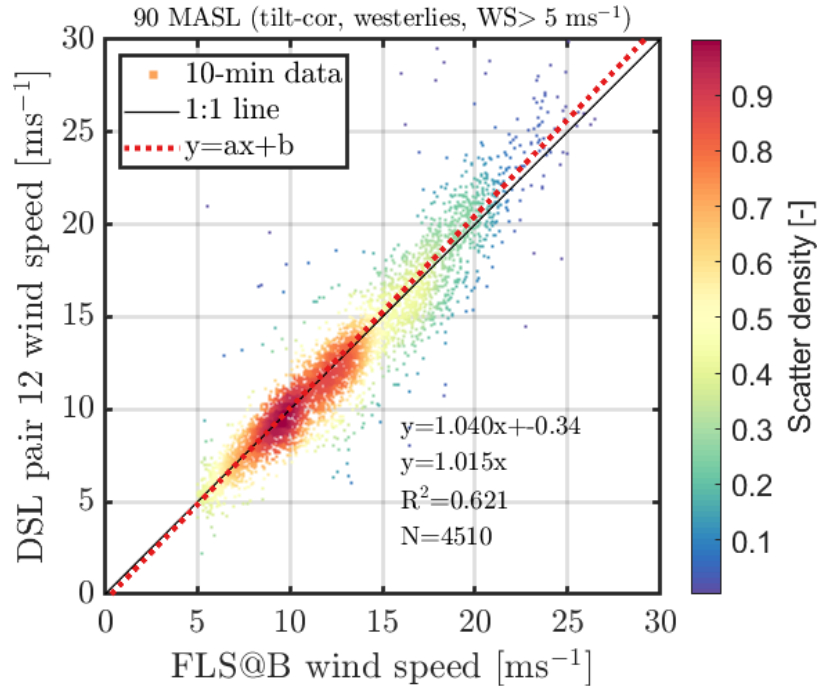

FLS@B vs. Dual-Doppler scanning lidar upstream Kaskasi

FLS@B vs. DD12 (Globe 1 + Globe 2, furthest reconstruction point) at 90 MASL

Tilt-corrected & pre-calibration offset vs. Tilt-corrected & pre-calibration offset & drone DSL >> Westerlies [220 deg, 340 deg] for WS>5 m/s

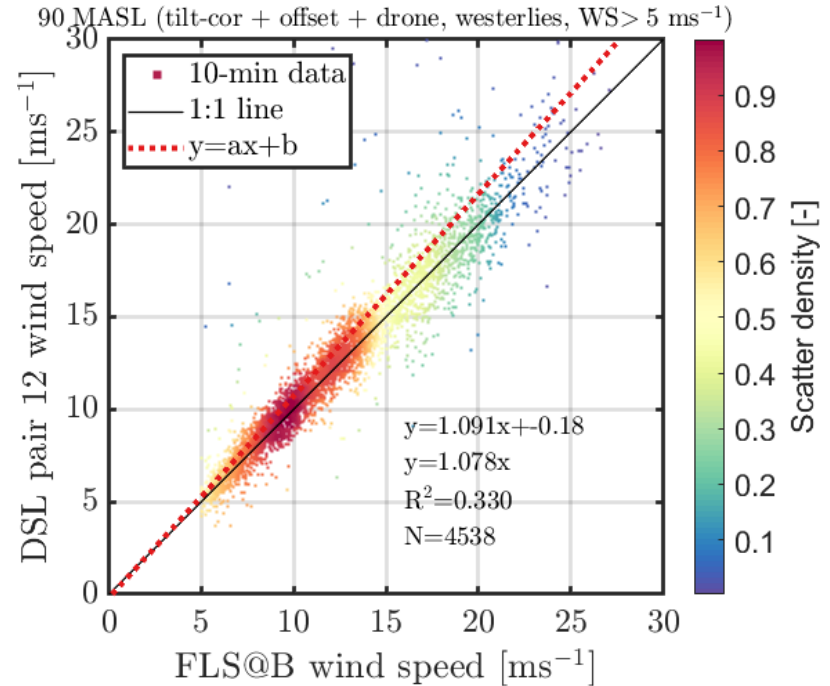
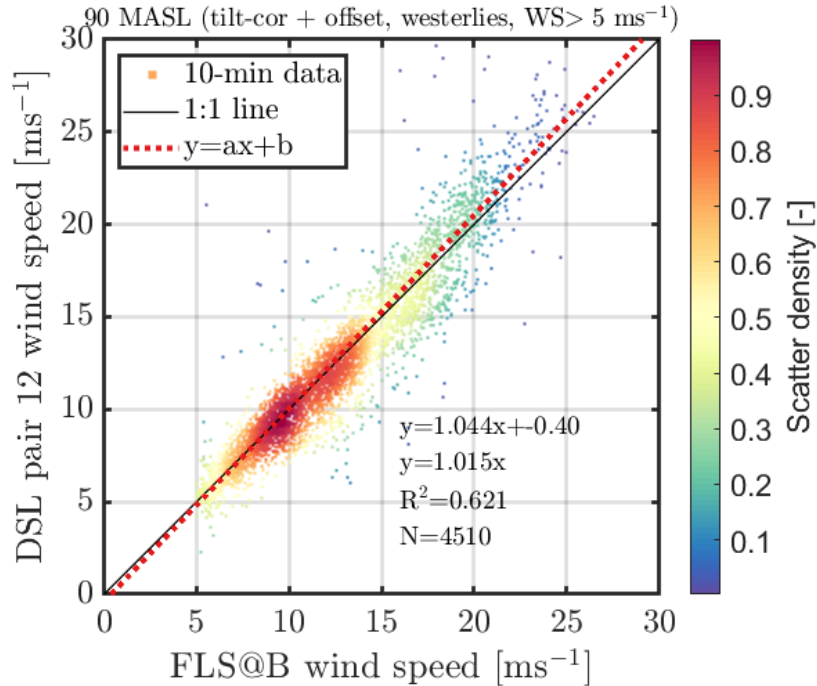

FLS@B compared with DD56

Distance between FLS@B and DD56 is 3.98 km

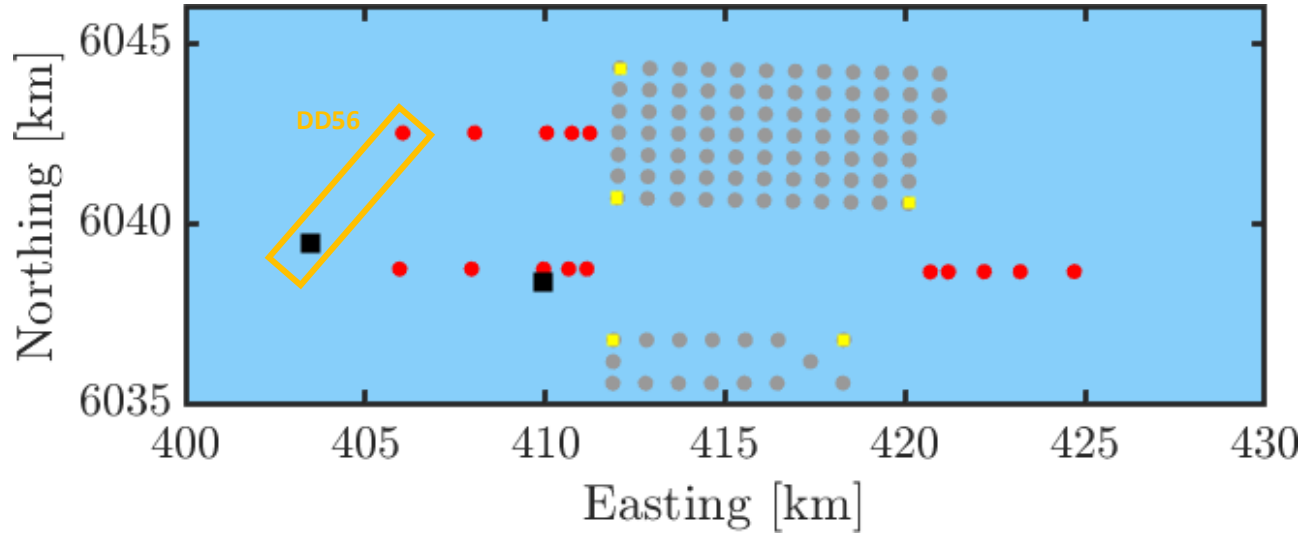

FLS@B vs. Dual-Doppler scanning lidar upstream Kaskasi

FLS@B vs. DD56 (Globe 5 + Globe 6, furthest reconstruction point) at 70 MASL

Tilt-corrected DSL vs. Tilt-corrected & drone DSL >>> Westerlies [220 deg, 340 deg] for WS>5 m/s

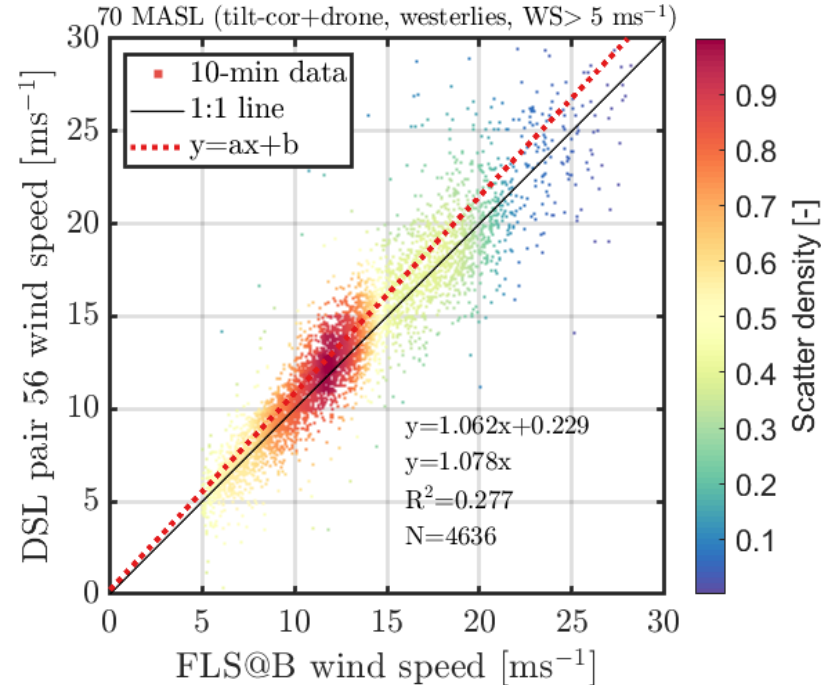
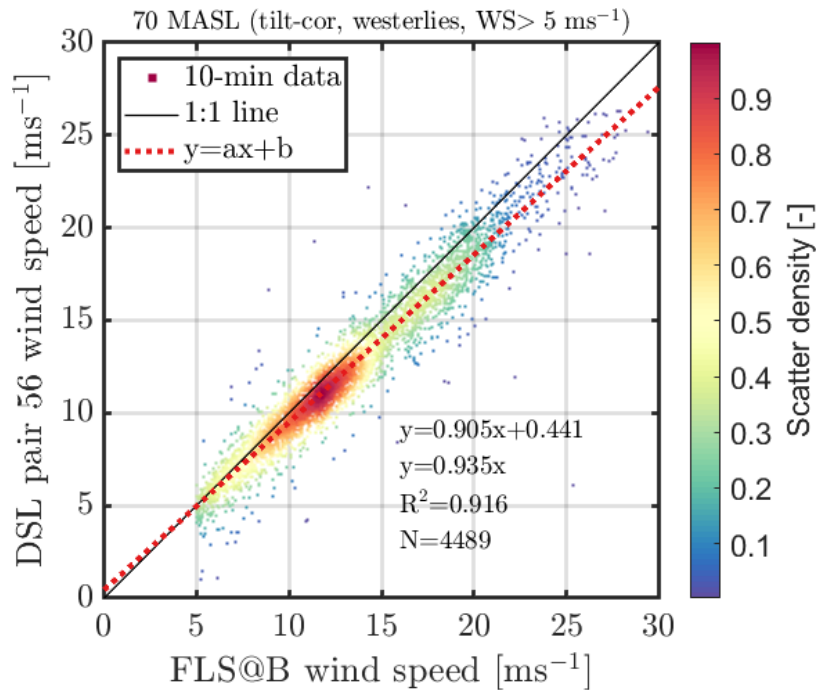

Conclusions

... of this presentation

- FLS is a useful tool to verify each Dual-Doppler correction step **using both positions A and B**;
- FLS shows that **drone corrections** might improve results at closest DD point, but overestimate (by a lot) at the furthest DD point, implying **unrealistic high wind speed ratios**.
- A **relative deviation greater than the FLS uncertainty can be used as a proxy** for further analysis and potentially for data filtering.



Thank you for listening.

Contact:

julia.gottschall@iwes.fraunhofer.de

Supported by:



Federal Ministry
for Economic Affairs
and Climate Action

on the basis of a decision
by the German Bundestag

© Fraunhofer IWES/Frank Bauer

Agenda



Chris Rodaway,
RWE Offshore Wind

Blockage: Background, Motivation and State of the Art



Chris Rodaway,
RWE Offshore Wind

Measurement Campaign Experimental Design



Dr Elliot Simon,
DTU Wind Energy

Mitigating Bias and Uncertainty in Offshore Wind LiDAR
Measurement Campaigns



Dr Julia Gottschall
Fraunhofer IWES

Verification of Offshore Scanning LiDAR Measurements using a
Floating Wind LiDAR System: the OWA-GloBE Case Study



Dr Graham Hawkes,
Frazer-Nash Consultancy

Rapid Blockage Model Development and Validation



Neil Adams,
Carbon Trust

Towards Industry Consensus on the Global Blockage Effect

GloBE: Rapid Blockage Model Development and Validation

Dr Graham Hawkes

Engineering Manager – Energy Technology

ONE KBR Technical Fellow

Royal Academy of Engineering Visiting Professor (University of Surrey)

Wind Energy Science Conference 2023, 23rd – 26th May Glasgow

Overview

- Motivation for a rapid blockage model
- Origins of the model
 - Potential flow (RHB) method and vortex analogues
 - Limitations and opportunities
- Algorithm Formulation
 - Modification to represent near wake expansion
 - Mimicking the effects of the atmospheric boundary layer cap
- Notes on implementation and coupling
- Ongoing Validation/Verification
 - Cluster configuration: Visual inspection and benchmarking
 - Planned validation activity
- Summary and questions

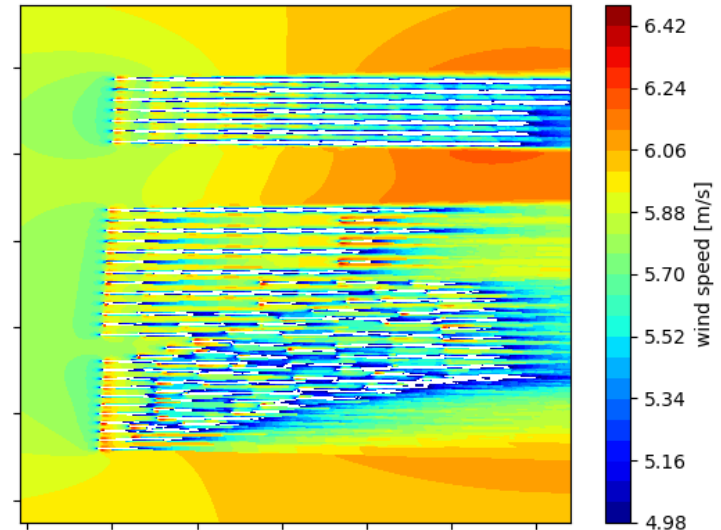

Families of Models: Motivation for a Rapid Model

Wake Modelling

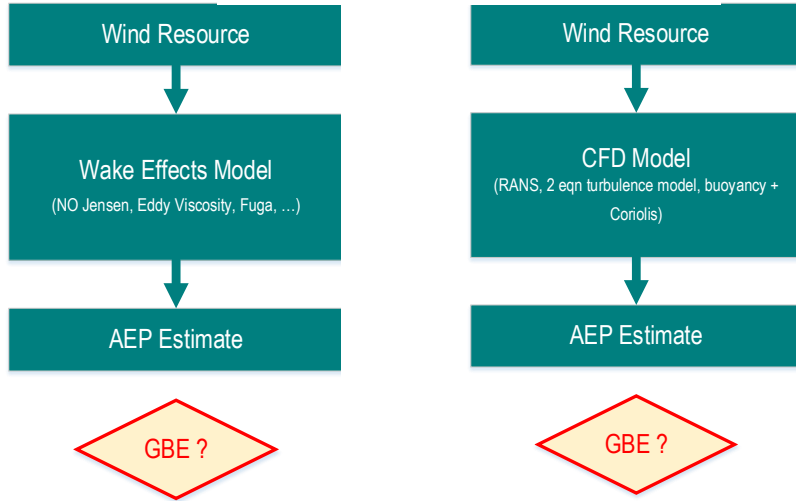

Rapid to afford layout optimisation, time-series analysis and ensembles

Detailed Physics, reduced assumption on wake spreading and superposition

Portfolio of Validation Evidence

Interaction (Wake and Blockage) Modelling

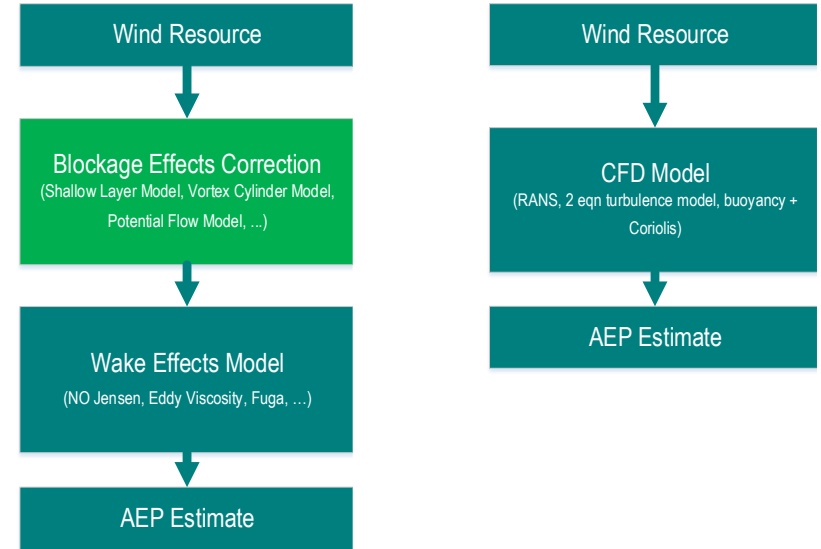

Rapid equivalent but with blockage (coupled model or correction?)

Detailed Physics, elliptic nature of equations affords upstream running effects

Limited Data or Validation Evidence

Origins of the model – Vortex / Potential Flow Analogy

- Evidence suggests that blockage contribution explained by conservation of mass within an inviscid framework is significant.
- Actuator disk theory describes existence of induction and expected behaviour far upstream/downstream and at rotor disk but not the continuous spatial variation of wind speed.
- **Vortex Cylinder (VC)**
 - Implementation of Branlard and Gaunaa (2014)
 - Assumes no-wake expansion
 - Requires solution of elliptic integrals
 - Assumes alignment with wind (yawed formulation available but not implemented)

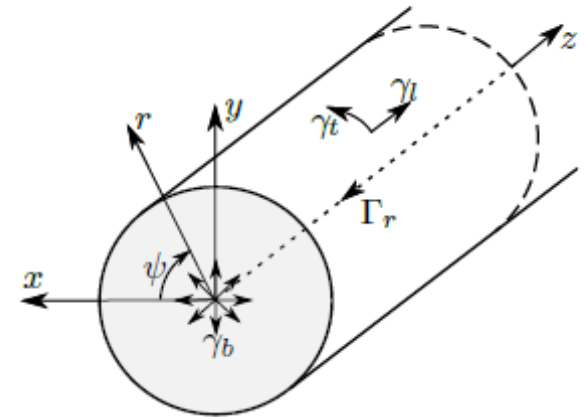

Schematic of the Vortex Cylinder Model, from Branlard ,E., and Gaunna, M., (2014) "Cylindrical vortex wake model: Right cylinder", Wind Energy 524(11)

Origins of the model – Vortex / Potential Flow Analogy

- Evidence suggests that blockage contribution explained by conservation of mass within an inviscid framework is significant.
- Actuator disk theory describes existence of induction and expected behaviour far upstream/downstream and at rotor disk but not the continuous spatial variation of wind speed.
- **Potential Flow – Rankine Half Body (RHB)**
 - Implementation of Gribben and Hawkes (2018)
 - Combines flow source and uniform stream, sized based on local flow conditions and thrust coefficient
 - Match annular mass flow between RHB surface and rotor diameter with the true induced flow across full rotor from 1D theory
 - Equivalent results to VC method >2D from each turbine
 - Naturally turns to face wind
 - Now available in PyWake and OpenWind

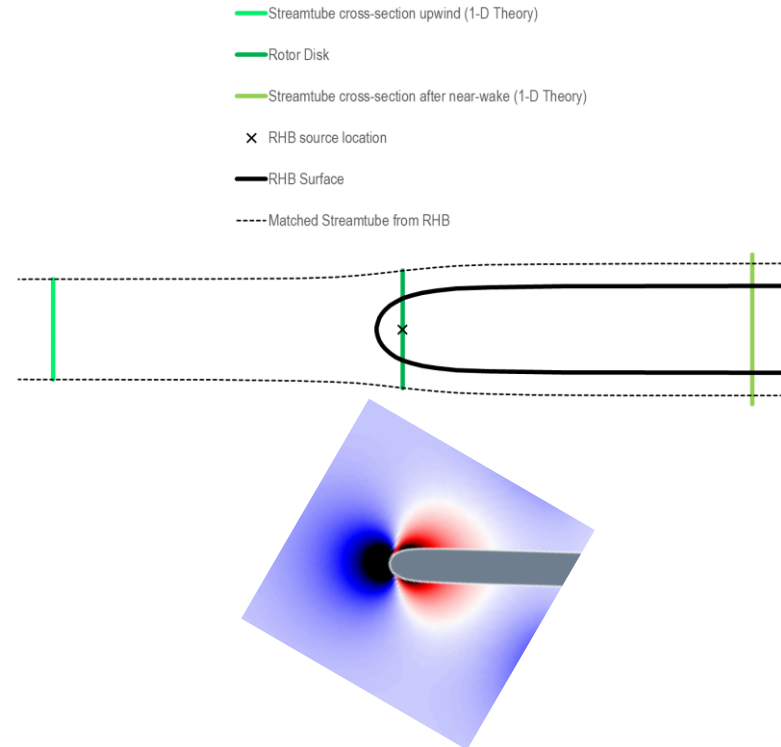

Origins of the model – Adding Wake Expansion

- VC and RHB models match flow from freestream into rotor
 - Tend to underestimate blockage and spatial deceleration into rotor disk
 - Straight row with wind perpendicular indicates no blockage
 - Need to consider near-wake expansion beyond rotor (distinct from mixing)
- **Vortex Ring Method (VR)**
 - Implementation of Øye (1990)
 - Incorporates near-wake expansion
 - Replace VC with a series of discrete VRs followed by a VC
 - Øye used 50 expanding rings (0.1R spacing) from 0-5R
 - Increasingly spaced fixed radius rings from 5R-10R
 - A VC beyond 10R
 - Uses continuity for local wake radius
 - More computationally involved

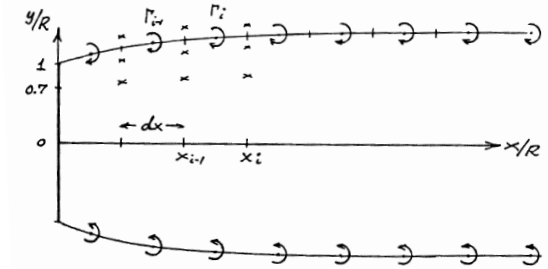

Schematic of the Vortex Ring Model, from Øye, S., (1990) "A simple vortex model", IEA.

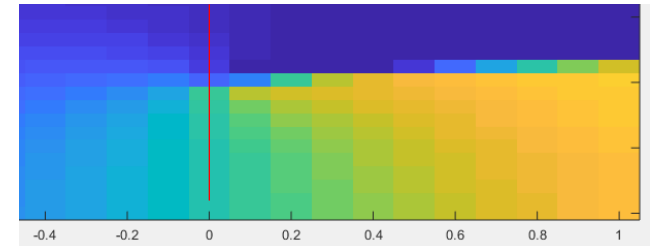

Axial flow perturbation from Vortex Ring Model. Turbine at position $x=0$ (red line), code courtesy of DTU.

Origins of the model – Adding Wake Expansion

- VC and RHB models match flow from freestream into rotor
 - Tend to underestimate blockage and spatial deceleration into rotor disk
 - Straight row with wind perpendicular indicates no blockage
 - Need to consider near-wake expansion beyond rotor (distinct from mixing)
- Enhanced Potential Flow Model - Rankine Half Body with Wake expansion (RHBW)**
 - Extension of RHB model to better mimic wake expansion
 - Continue vortex and potential flow analogy – many rings = many sources
 - Simplest possible solution has a single flow source (strength m) located a distance (x) behind the turbine.
 - m and x are solved to match stream-tube mass flow at rotor plane and far downstream
 - Not identical to VR but ... $(RHBW - VR) \ll (RHBW - RHB)$ and fast
 - Not currently available in opensource or commercial code
 - One of the many models considered within GloBE

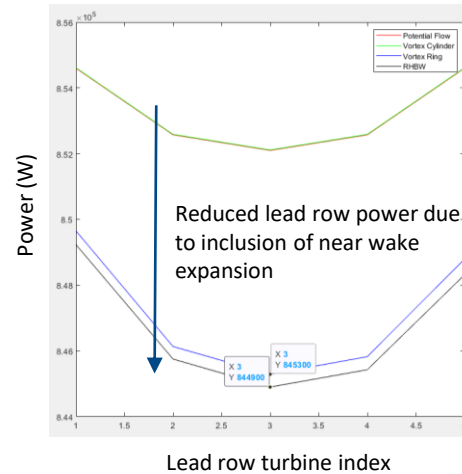
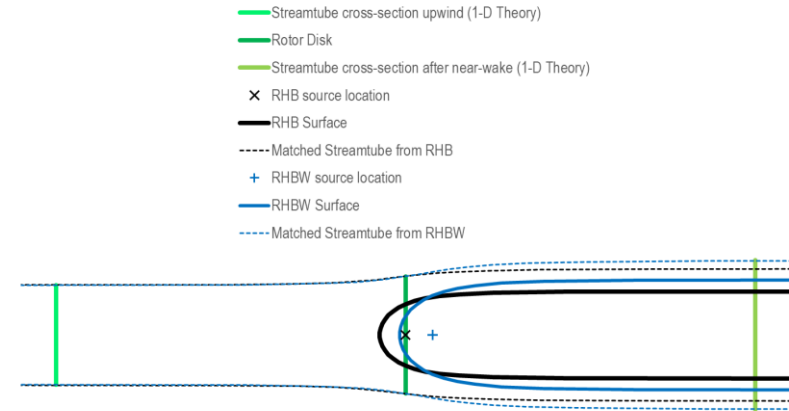

Lead row power offtake comparing various blockage methods. 5x5 regular array test case with normally incident wind.

RHBW Formulation

- The full derivation is not presented here but method follows:
 - Match annular flow between local RHB surface and streamtube extent and 1D theory
 - 2 constraints: at rotor plane and after near wake expansion
 - 2 unknowns: source strength (m), source displacement (d_w)
- For a given inflow (U), rotor area (A) and induction parameter ($a = f(C_t)$):

	RHB	RHBW
Source Strength, m	$2AUa$	$2AUa \left(\frac{1-a}{1-2a} \right)$
Downwind Source Displacement, d_w	0	$a \sqrt{\frac{A}{\pi(1-2a)}}$

- Perturbed velocity field given by:

$$u = U + \frac{m}{4\pi} \frac{x_1 - x_T - d_w}{\{(x_1 - x_T - d_w)^2 + (y_1 - y_T)^2 + (z_1 - h)^2\}^{3/2}}$$

(x_1, y_1, z_1) = query point

(x_T, y_T, h) = source rotor centre

Representing Constraints

- Within the original RHB model (and the VC model) a non-penetrable but slipping ground constraint is represented using the Methods of Images
- There is evidence from models, measured data and published literature to suggest that blockage is also influenced by the thermal profile in the atmosphere
- The profile has a number of characteristic and interlinked parameters:
 - Surface heat flux
 - Inversion strength
 - Upper atmosphere lapse rate
 - Atmospheric boundary layer height
- In its simplest form the atmospheric cap can be modelled as a hard constraint, akin to the ground, creating a horizontal flow channel
- How do we do this?

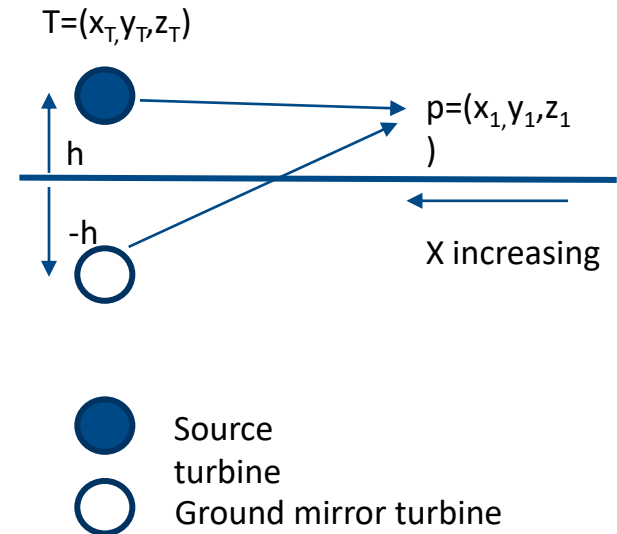

Representing Constraints

- Start with turbine/mirror system

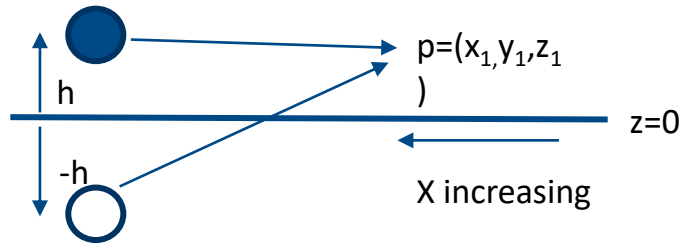

Representing Constraints

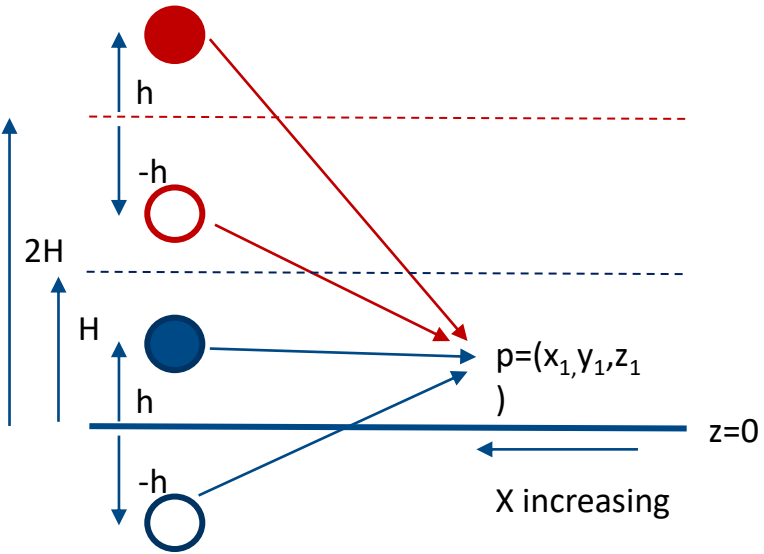

- Start with turbine/mirror system
- Add a duplicate turbine/mirror combination offset by $z=+2H$
 - System is now symmetric around $z=H$ (cap)
 - System is no longer symmetric around $z=0$ (ground)

Representing Constraints

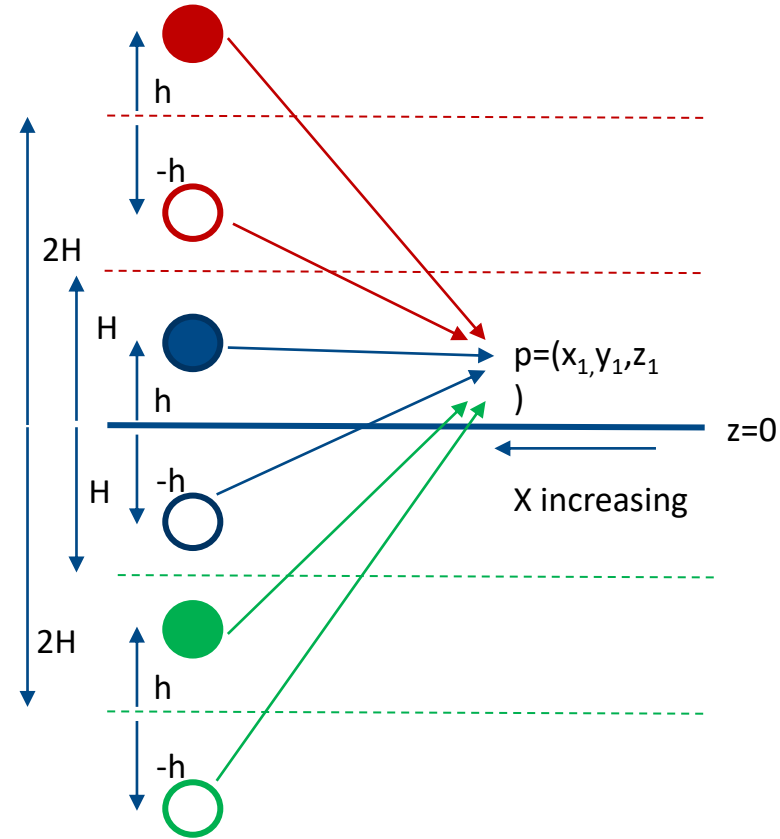

- Start with turbine/mirror system
- Add a duplicate turbine/mirror combination offset by $z=+2H$
 - System is now symmetric around $z=H$ (cap)
 - System is no longer symmetric around $z=0$ (ground)
- Add a duplicate turbine/mirror combination offset by $z=-2H$
 - System is now symmetric around $z=0$ (ground)
 - System is not symmetric around $z=H$ (cap) nor $z=-H$ but weakly so
- Symmetry around $z=0$ and $z=H$ is achieved with an infinite number of repeats with $\pm 2H$ separation.
- But the ground is impenetrable ... impenetrable caps are an approximation, benefit for rigorous enforcement is limited.

Representing Constraints

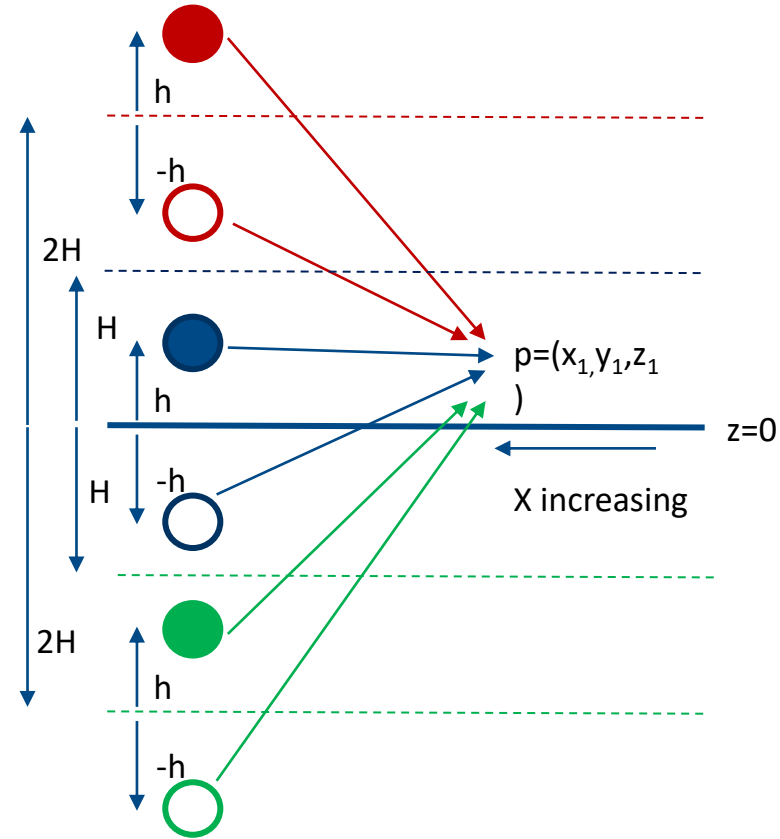

- We can do this algebraically, no need to repeat layouts

$$u = U + \frac{m}{4\pi} \sum_{n=-\infty}^{\infty} \frac{x_1 - x_T - d_w}{\{(x_1 - x_T - d_w)^2 + (y_1 - y_T)^2 + (z_1 - 2nH - h)^2\}^{3/2}} + \frac{m}{4\pi} \sum_{n=-\infty}^{\infty} \frac{x_1 - x_T - d_w}{\{(x_1 - x_T - d_w)^2 + (y_1 - y_T)^2 + (z_1 - 2nH + h)^2\}^{3/2}}$$

- Don't have a closed form infinite solution
 - Influences become vanishingly small quickly
 - Truncate summation when $|n| \sim W/2H$, where W = farm width
 - Typically $n = 5$ to 10 is sufficient
- Key assumption:
 - A power curve = the performance of a single turbine plus its ground and cap mirrors
 - Consider blockage effects on neighbours only

Model Coupling

- The model has been implemented in both Matlab and PyWake
 - Matlab – bespoke for initial development, single wake model
 - PyWake – extendable and enables a wider wake model suite
- As with wake loss, heuristic assumptions are required
 - Means of summing field perturbations
 - Averaging field conditions over rotor planes
 - Do not rigorously conserve mass/momentum
- Many options are available for wake superposition / rotor averaging
 - Wakes and blockage can be treated the same or differently
 - Local linear superposition is attractive (as potential flow approach)
 - Blockage field spatial gradients are generally lower than for wakes
 - Needs validation data to advise on specific schemes and tunings
- When coupling you will need to re-tune your “wakes only” wakes model

Compute influence
from neighbours

Update turbine
performance based
on perturbed inflow

Compute influence
contribution from
turbine to
neighbours

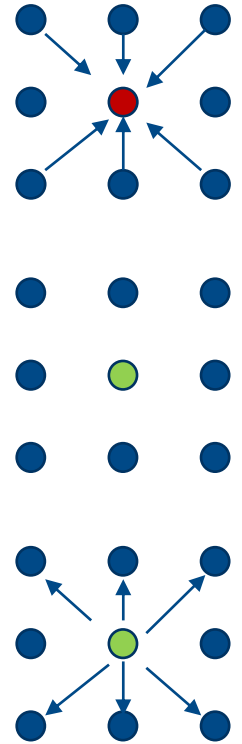

Model Test: Heligoland Cluster – Flow Field Features

Farmscale slow down ahead of wind farm

High frequency lumps at turbine locations:

- RHBW model creates stagnation points near turbines
- Field only valid away from turbines
- Model removes self-perturbations for power calculations

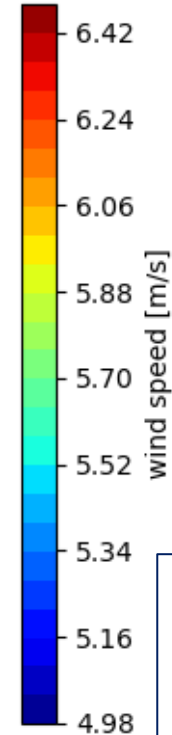
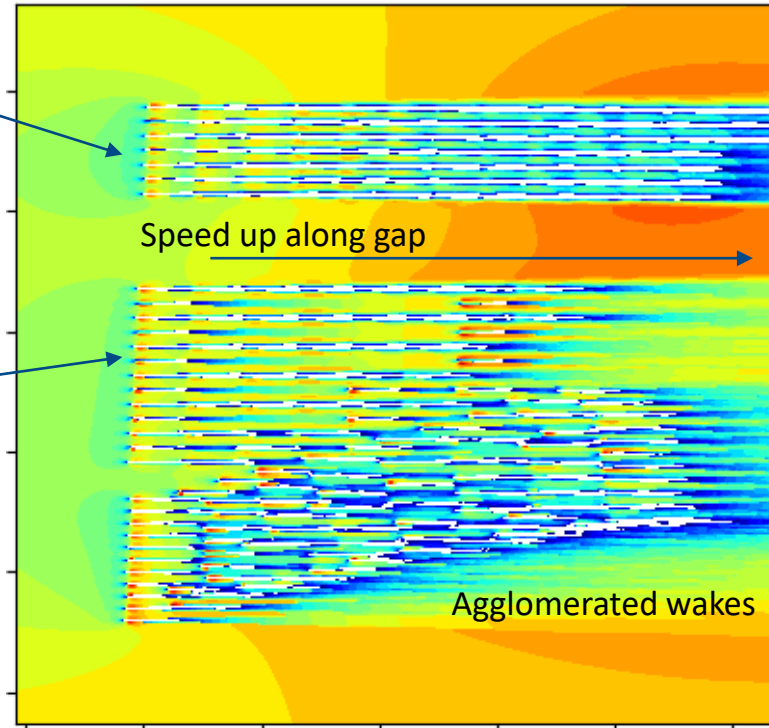

Wind Speed: 6m/s
Wind Direction: 270°
Wakes: Bastankhah Gaussian
Blockage: RHBW + ABL
Coupling: Local Linear

Model Test – ABL Height Sensitivity

- More pronounced slowdowns and speed ups in gap with lower ABL height

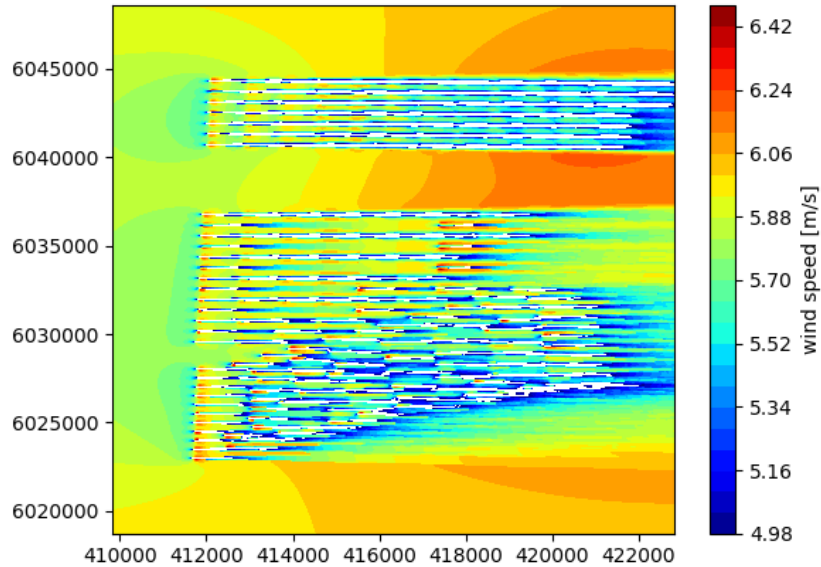

PBL 1,000m

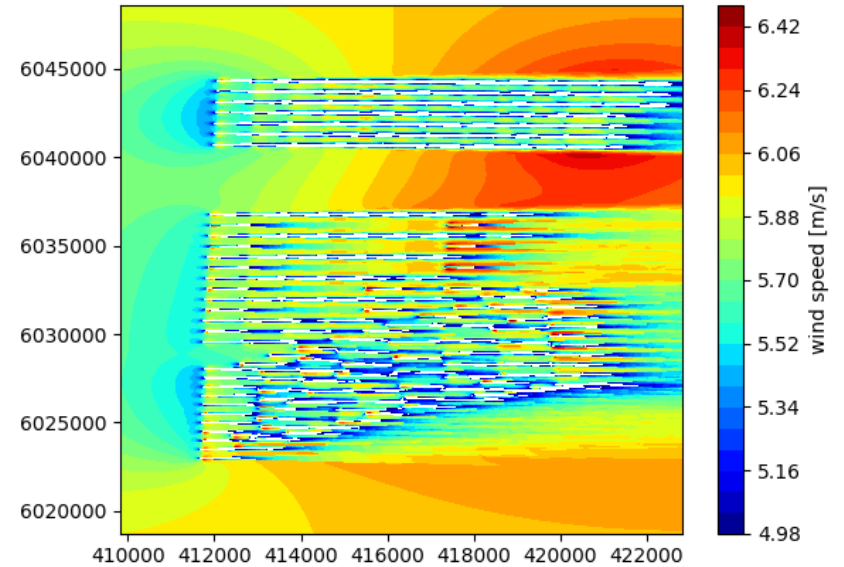

PBL 400m

Model Test – High / Low Fidelity Comparison

Single Turbine Induction

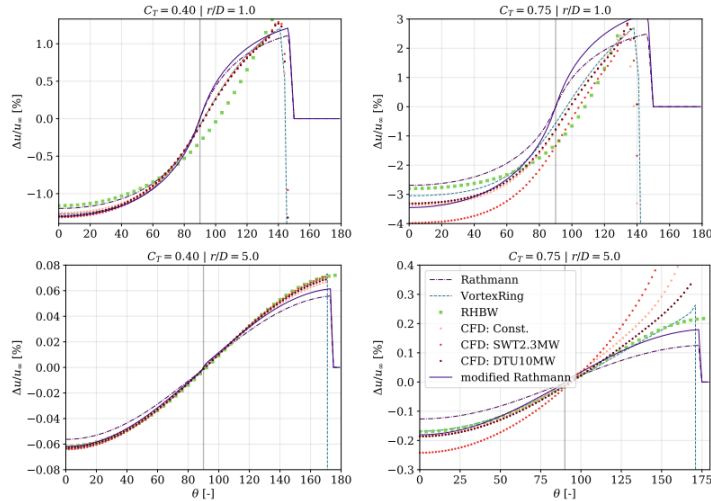

Images from A Meyer Forsting et al 2021 J. Phys.: Conf. Ser. 1934 012023

- Meyer Forsting et al benchmarked predictions against a range of blockage models and RANS-AD CFD for a single turbine.
- *“A new Rankine-half-body model with wake expansion (RHBW) predicts blockage-related velocity perturbations similar to RANS-AD simulations at the computational cost of the fastest blockage models available”.*

Heligoland Cluster Gap

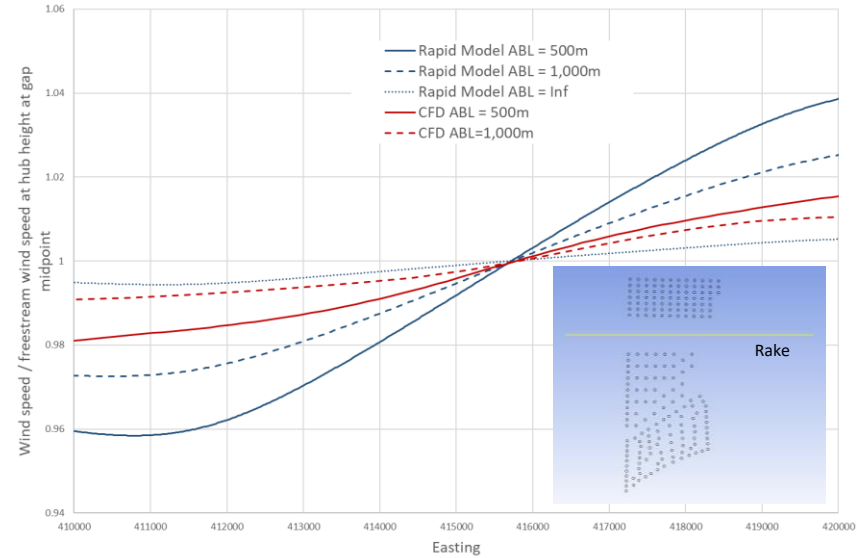

- Rapid Model / CFD for cluster gap hub height wind speed
- RHBW-Wake coupled model predicts similar slowdown/speed up shape in gap to CFD
- ABL height sensitivity stronger in rapid model (hard cap)
- Validation and calibration opportunity?

Summary

- A new rapid model for blockage (RHBW) has been developed within the OWA programme and implemented and verified for the GloBE project.
- The model is potential flow based and incorporates effects of near wake expansion more fully than in the original RHB implementation. This has the effect of increasing longitudinal blockage and making lateral blockage non-zero.
- The model tenet is based on extending the vortex – potential flow analogy found between the Vortex Cylinder and RHB models to develop a potential flow analogue to the more involved Vortex Ring methods.
- An approach has been implemented based on the method of images to provide some sensitivity to the height of the atmospheric boundary layer cap.
- Validation against field data from GloBE is ongoing but verification tests against higher fidelity methods (CFD) is very promising.

Authors and Acknowledgements

- Graham Hawkes (Frazer-Nash)
 - Project lead and originator of RHBW concept and stacking algorithm
- Brian Gribben (Frazer-Nash)
 - Originator of the precursor RHB concept and mathematical derivation of RHBW algorithm
- Nicolai Nygaard (Ørsted)
 - Identifier of algorithmic shortcuts and proof of universality of definitions within RHBW
- Daniel Powell (Frazer-Nash)
 - Implementation of RHBW in PyWake and running verification models
- Lauren Johnston (Frazer-Nash)
 - Running high fidelity CFD models for verification

We would also like to acknowledge the support of the Offshore Wind Accelerator (OWA) and GloBE Consortium for the permission to implement and publish this work. We would also like to acknowledge the support of DTU in the original OWA work, initial benchmarking of RHBW and for their assistance with PyWake.

Thank You

Dr Graham Hawkes g.hawkes@fnc.co.uk

Engineering Manager – Energy Technology

ONE KBR Technical Fellows

Royal Academy of Engineering Visiting Professor (University of Surrey)

May 2023

Agenda



Chris Rodaway,
RWE Offshore Wind

Blockage: Background, Motivation and State of the Art



Chris Rodaway,
RWE Offshore Wind

Measurement Campaign Experimental Design



Dr Elliot Simon,
DTU Wind Energy

Mitigating Bias and Uncertainty in Offshore Wind LiDAR
Measurement Campaigns



Dr Julia Gottschall
Fraunhofer IWES

Verification of Offshore Scanning LiDAR Measurements using a
Floating Wind LiDAR System: the OWA-GloBE Case Study



Dr Graham Hawkes,
Frazer-Nash Consultancy

Rapid Blockage Model Development and Validation



Neil Adams,
Carbon Trust

Towards Industry Consensus on the Global Blockage Effect



OWA GLOBE MINI-SYMPOSIUM

Towards Industry Consensus on the Global Blockage Effect

Neil Adams, Carbon Trust

Chris Rodaway, RWE

24th May 2023

Why Focus on Consensus?

Energy yield uncertainty increases costs and slows build-out

Offshore wind farm project investment



in construction capital expenditure needed to build offshore windfarms in the UK by 2030¹

UK Government Offshore Wind Net Zero Investment Roadmap, March 2023

https://assets.publishing.service.gov.uk/government/uploads/system/uploads/attachment_data/file/1148650/offshore-wind-net-zero-investment-roadmap.pdf

Offshore forecast fears blow through European wind farms

Independent consultants believe long-held industry assumptions may be understating wind effects

5 Jan. 2020
Financial Times

'Blockage-effect insight shows science of wind still evolving'

Ørsted's production forecast revision put the issue in the spotlight, but better understanding of such phenomena can only help the industry long-term

28 Nov. 2019
Recharge

Offshore wind production forecasts are inflated, world's largest developer warns

30 Oct, 2019
S&P Global Market Intelligence

Forum for Consensus-Building: GloBE Stakeholders

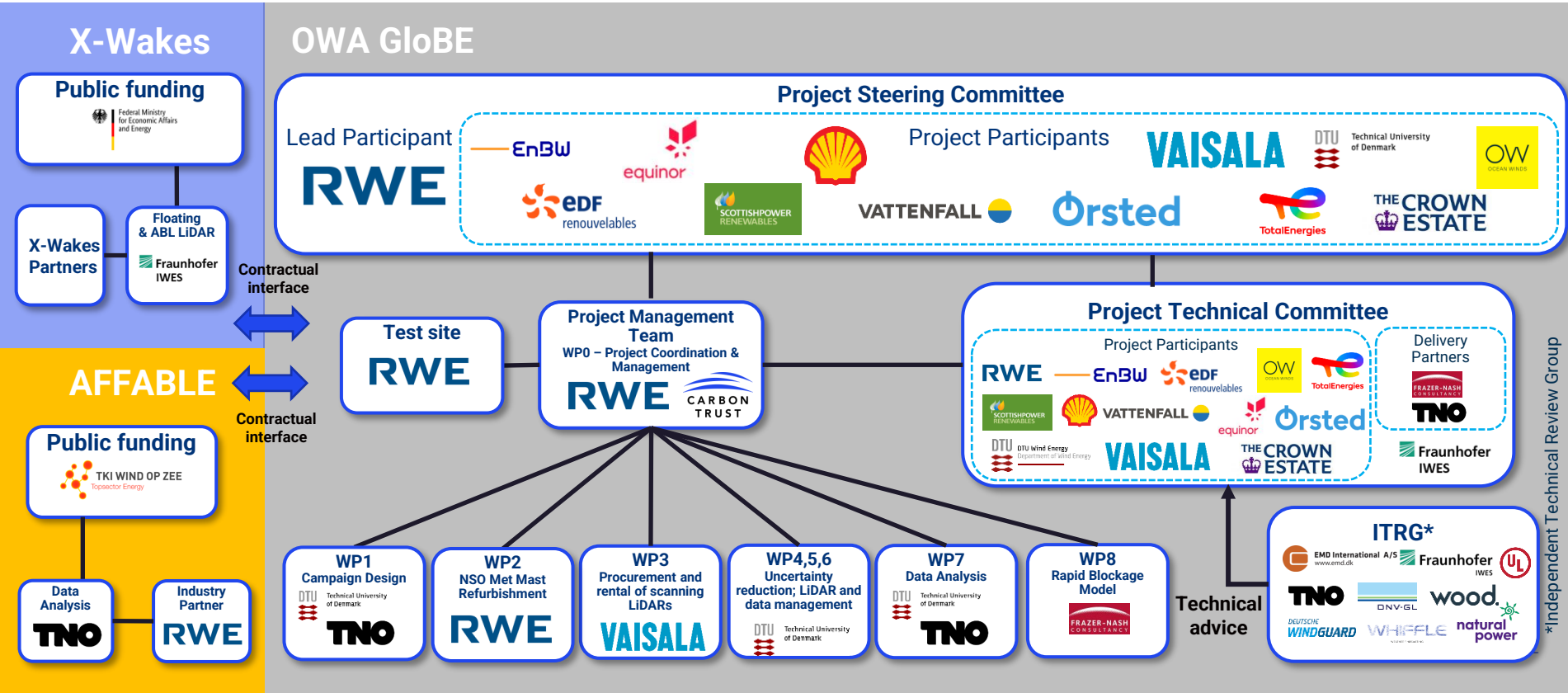

*Independent Technical Review Group

Forum for Consensus-Building: ITRG



Independent Technical Review Group



Why is Consensus Hard to Achieve?

- Lack of evidence
- Disentangling blockage from other effects

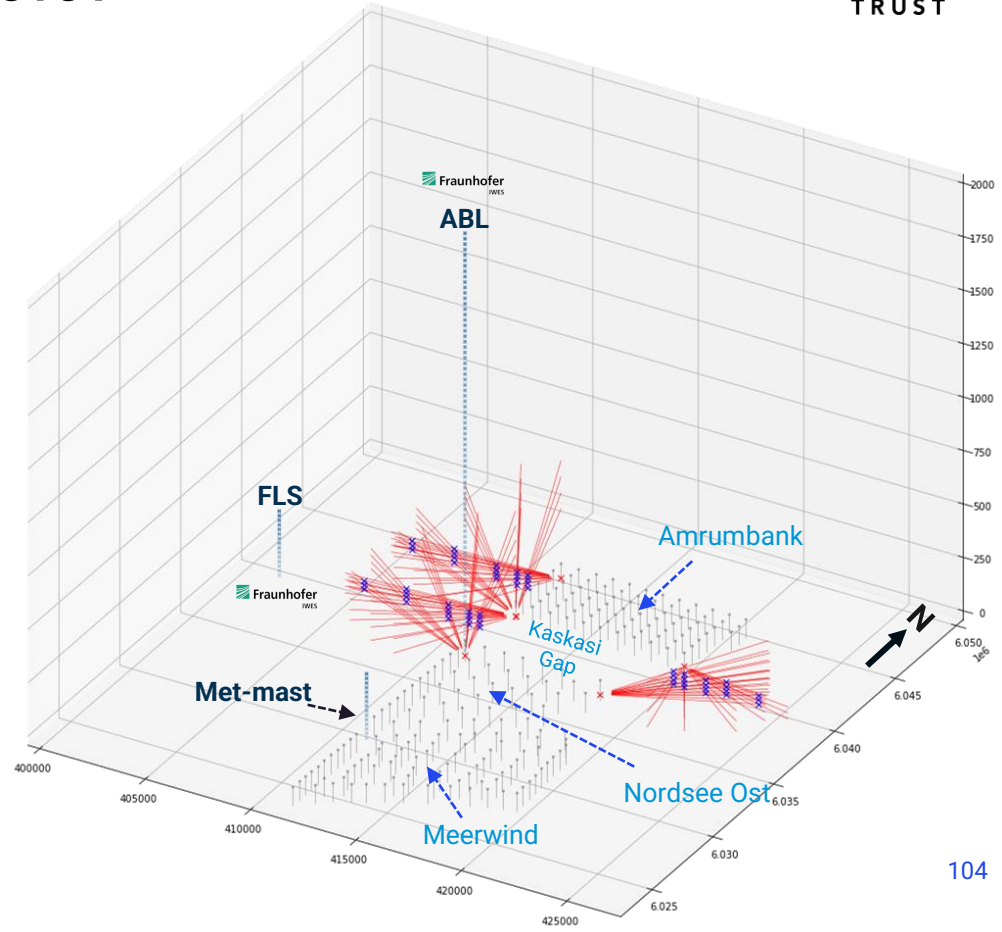

Why is Consensus Hard to Achieve?

- Lack of evidence
- Disentangling blockage from other effects
- Diversity of approaches (including integrating into legacy toolsets and best practice)

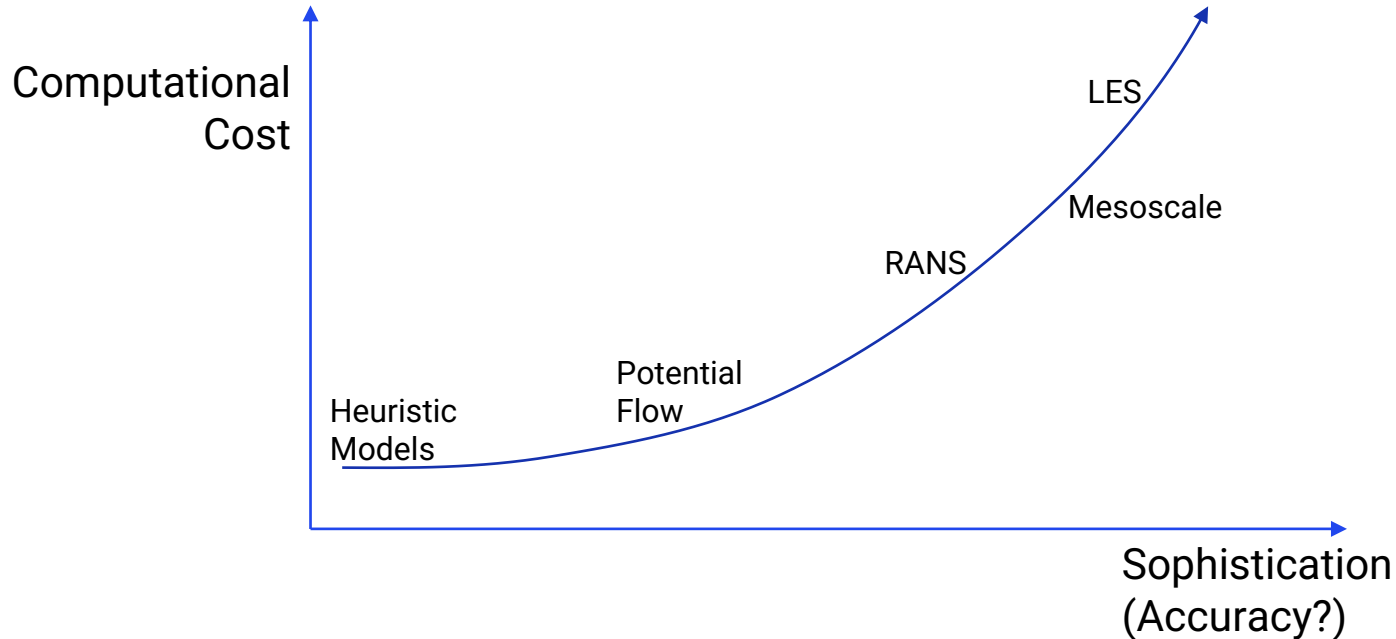

Why is Consensus Hard to Achieve?

- Lack of evidence
- Disentangling blockage from other effects
- Diversity of approaches (including integrating into legacy toolsets and best practice)
- Diversity of philosophies

Inside, Around and Above the Wind Farm		
Upstream of the Wind Farm		
	Viscous Effects	Inviscid Effects

Why is Consensus Hard to Achieve?

- Lack of evidence
- Disentangling blockage from other effects
- Diversity of approaches (including integrating into legacy toolsets and best practice)
- Diversity of philosophies

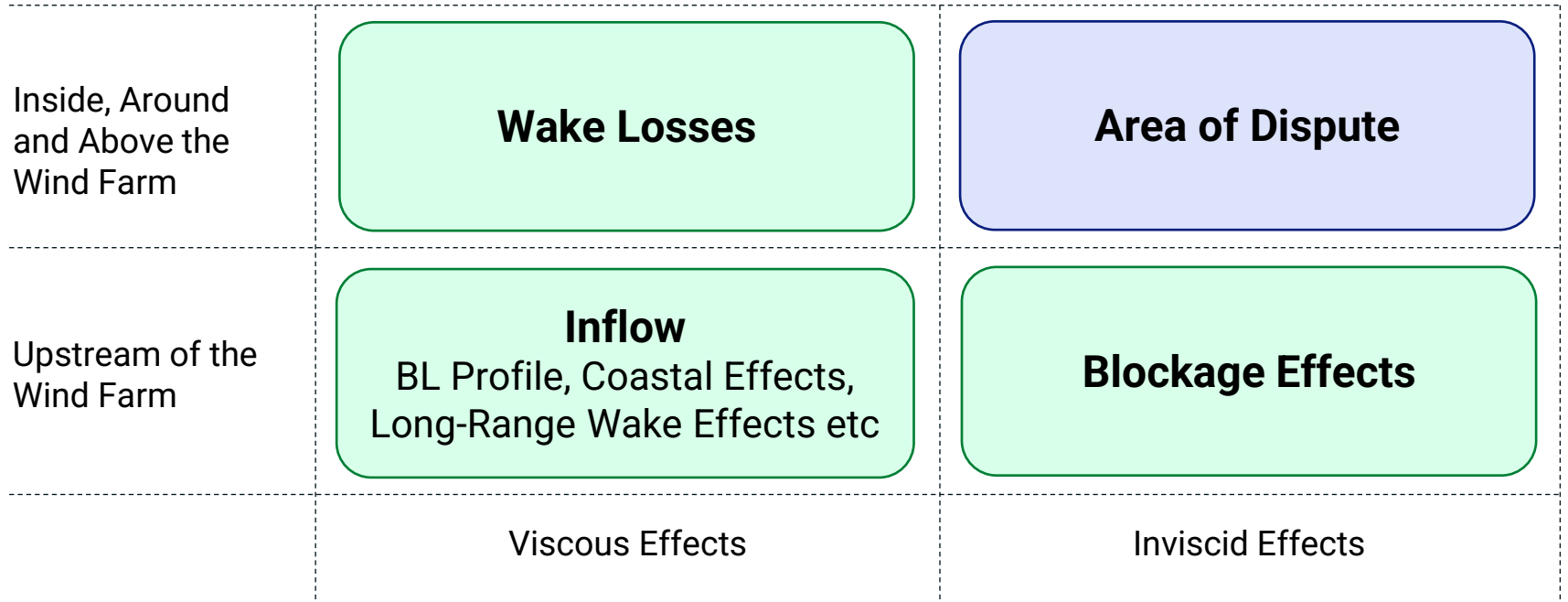

Why is Consensus Hard to Achieve?

- Lack of evidence
- Disentangling blockage from other effects
- Diversity of approaches (including integrating into legacy toolsets and best practice)
- Diversity of philosophies

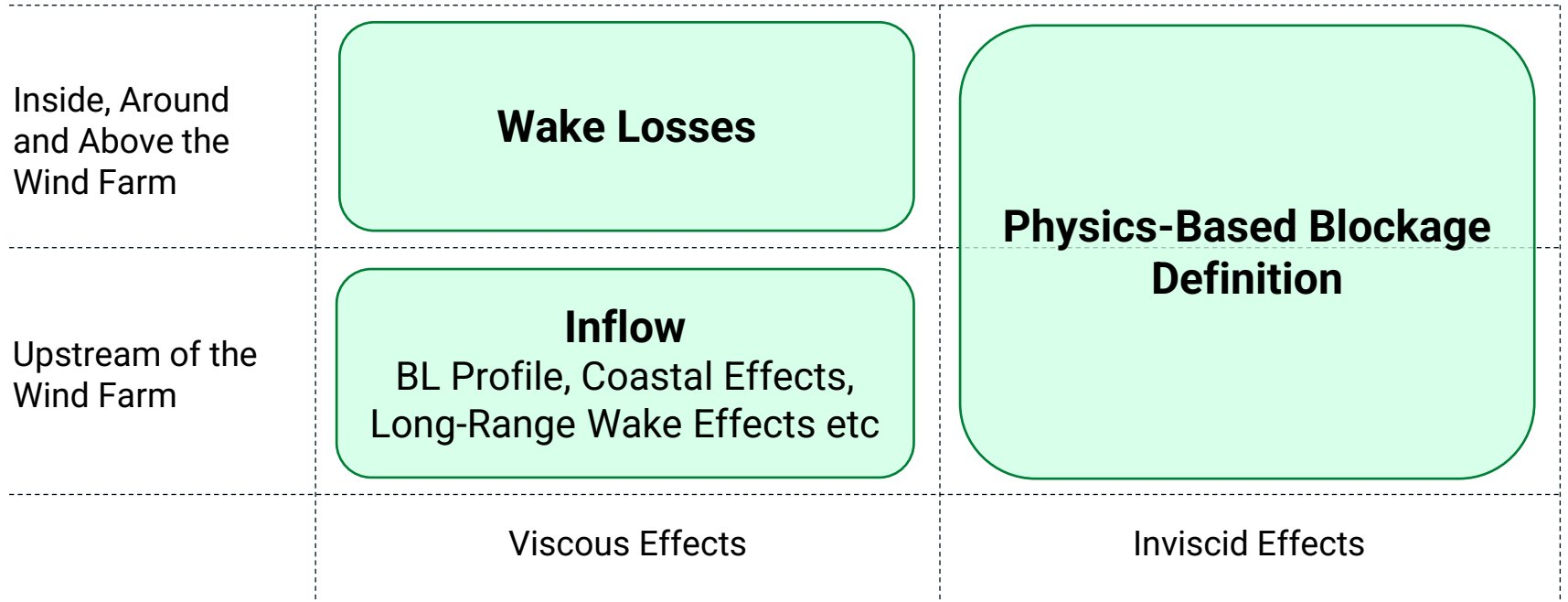

Why is Consensus Hard to Achieve?

- Lack of evidence
- Disentangling blockage from other effects
- Diversity of approaches (including integrating into legacy toolsets and best practice)
- Diversity of philosophies

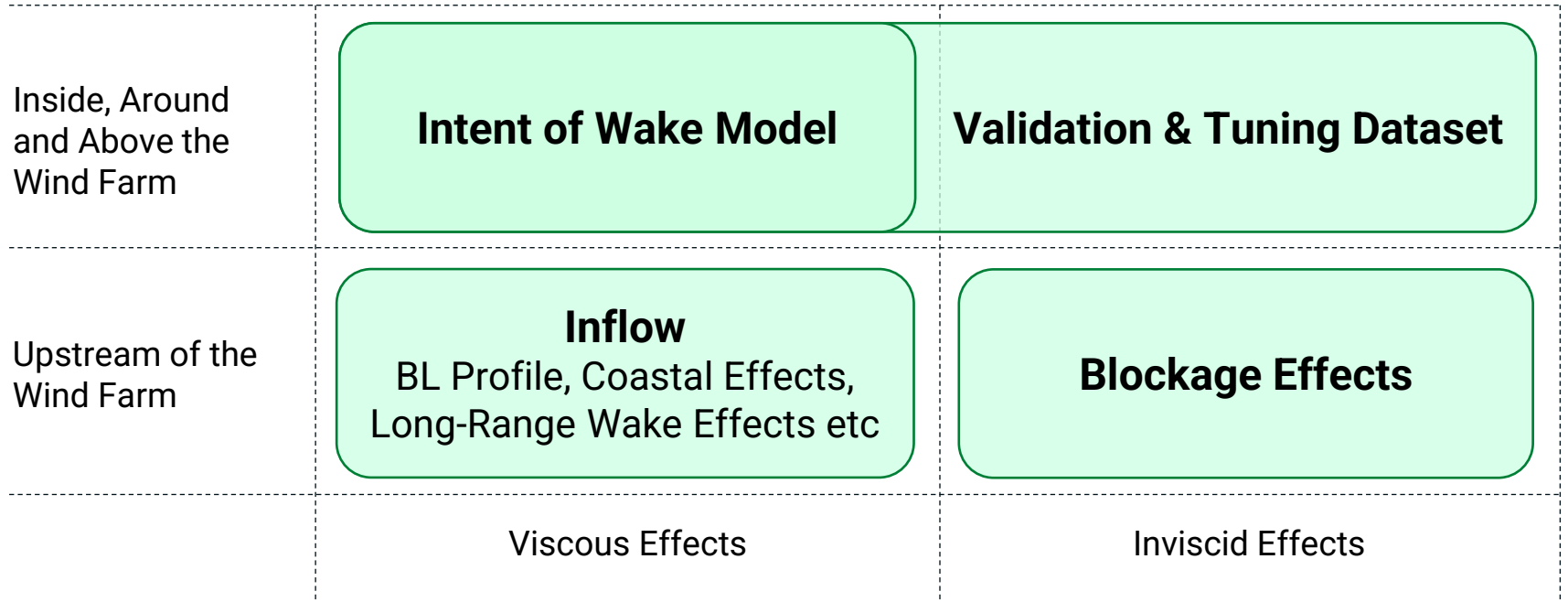

Importance of Solution-Agnostic Terminology

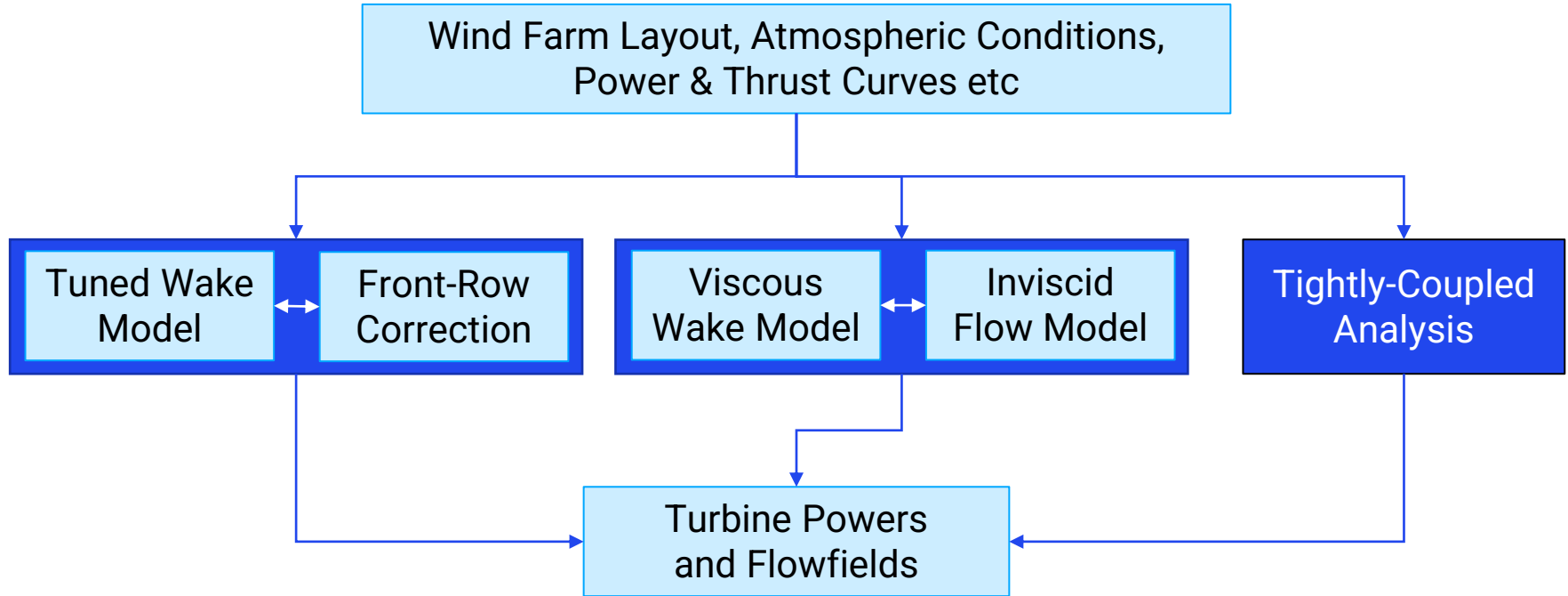

What's the blockage effect?

Areas of Potential Consensus

- ✘ Precisely what “blockage” means
- ✘ What modelling approach should be used

- ✓ Solution-agnostic terminology
- ✓ How to compare models with measurements
- ✓ How to deal with various challenges in measured data
- ✓ How to perform a fair yet robust validation

- ? What physics need to be captured to predict blockage
- ? What blockage is sensitive to, and what models can capture this sensitivity
- ? How to account for blockage in yield predictions (losses & uncertainties)

Solution-Agnostic Terminology

- ✗ ~~Blockage effect~~
- ✗ ~~Blockage loss~~
- ✗ ~~Wake loss~~

- ✓ Turbine Interaction Loss
- ✓ Array Efficiency
- ✓ Non-Waked Turbine Array Efficiency
- ✓ Potentially-Waked Turbine Array Efficiency
- ✓ Speed-Up / Slow-Down

Solution-Agnostic Terminology

- ✗ ~~Blockage-effect~~
- ✗ ~~Blockage-loss~~
- ✗ ~~Wake-loss~~

- ✓ Turbine Interaction Loss
- ✓ Array Efficiency
- ✓ Non-Waked Turbine Array Efficiency
- ✓ Potentially-Waked Turbine Array Efficiency
- ✓ Speed-Up / Slow-Down

Turbine Interaction Loss is defined as 100% minus the **Array Efficiency** of a specific turbine or the full wind farm for a specific wind speed & direction / specific instant in time or the full wind rose

It is applicable to any modelling approach and any wind farm or cluster

$$TIL = 100\% - \eta_{Array}$$

$$\overline{TIL} = 100\% - \overline{\eta_{Array}}$$

Solution-Agnostic Terminology

- ✗ Blockage-effect
- ✗ Blockage-loss
- ✗ Wake-loss
- ✓ Turbine Interaction Loss
- ✓ Array Efficiency
- ✓ Non-Waked Turbine Array Efficiency
- ✓ Potentially-Waked Turbine Array Efficiency
- ✓ Speed-Up / Slow-Down

Array Efficiency is the ratio of the power produced by a wind turbine to the power that it would have produced if it did not experience an aerodynamic interaction effect from any other turbines

It can be expressed in terms of:

- Power output for a specific turbine and a specific wind speed and direction / specific instant in time
- The full wind farm for a specific wind speed and direction
- The full wind farm averaged across the entire wind rose (or through time)

$$\eta_{Array,Turbine} = \frac{P_{InArray}}{P_{InIsolation}}$$

$$\eta_{Array,Farm} = \frac{\sum_1^{nTurbines} P_{InArray}}{\sum_1^{nTurbines} P_{InIsolation}}$$

$$\overline{\eta_{Array,Farm}} = \frac{\int_0^{2\pi} \int_0^{v_{max}} \sum_1^{nTurbines} P_{InArray} \cdot p(v, \theta) dv d\theta}{\int_0^{2\pi} \int_0^{v_{max}} \sum_1^{nTurbines} P_{InIsolation} \cdot p(v, \theta) dv d\theta}$$

Solution-Agnostic Terminology

- ✗ ~~Blockage effect~~
- ✗ ~~Blockage loss~~
- ✗ ~~Wake loss~~

- ✓ Turbine Interaction Loss
- ✓ Array Efficiency
- ✓ Non-Waked Turbine Array Efficiency
- ✓ Potentially-Waked Turbine Array Efficiency
- ✓ Speed-Up / Slow-Down

Only meaningful for a specific wind speed and direction range with consistent sets of non-wake-affected / potentially-wake-affected turbines

Non-Waked Turbine Array Efficiency is the average array efficiency of the non-wake-affected turbines (green below, 30° angle debatable!)

Potentially-Waked Turbine Array Efficiency is the average array efficiency of the non-wake-affected turbines (red below, 30° angle debatable!)

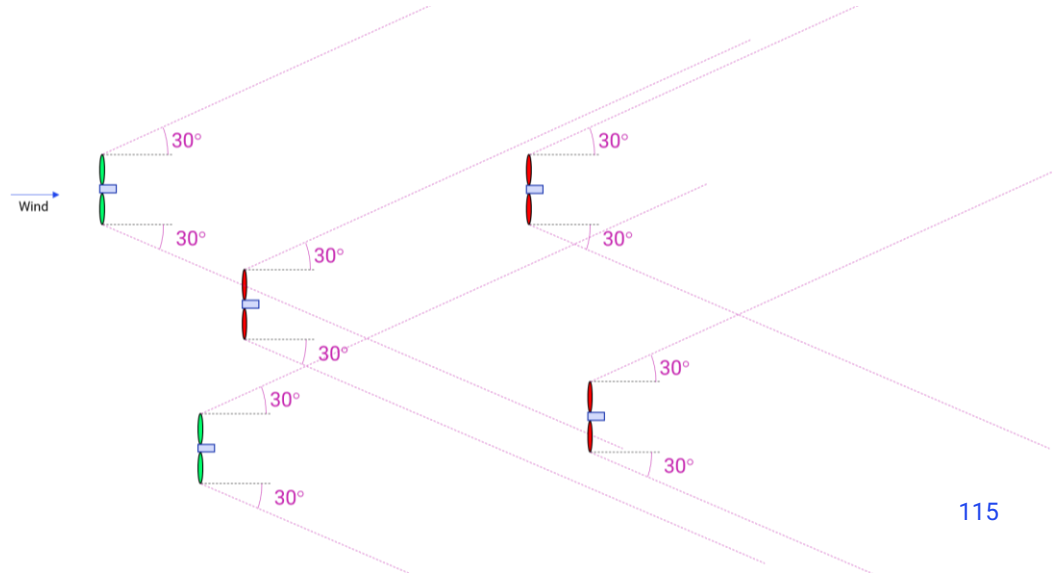

Solution-Agnostic Terminology

- ✗ ~~Blockage-effect~~
- ✗ ~~Blockage-loss~~
- ✗ ~~Wake-loss~~

- ✓ Turbine Interaction Loss
- ✓ Array Efficiency
- ✓ Non-Waked Turbine Array Efficiency
- ✓ Potentially-Waked Turbine Array Efficiency
- ✓ Speed-Up / Slow-Down

Speed-Up and Slow-Down are defined as the change in wind speed at a particular location compared to the wind speed that would have existed in the absence of any wind turbines

It is expressed as a percentage of the wind speed that would have existed in the absence of any wind turbines

It is meaningful for a specific wind speed and direction / specific instant in time, or averaged across a defined range of wind speeds & directions or a specific time interval

In some cases, “the wind speed that would have existed in the absence of any wind turbines” is unknowable so **wind speed ratios** between different locations are used instead

Towards Consensus

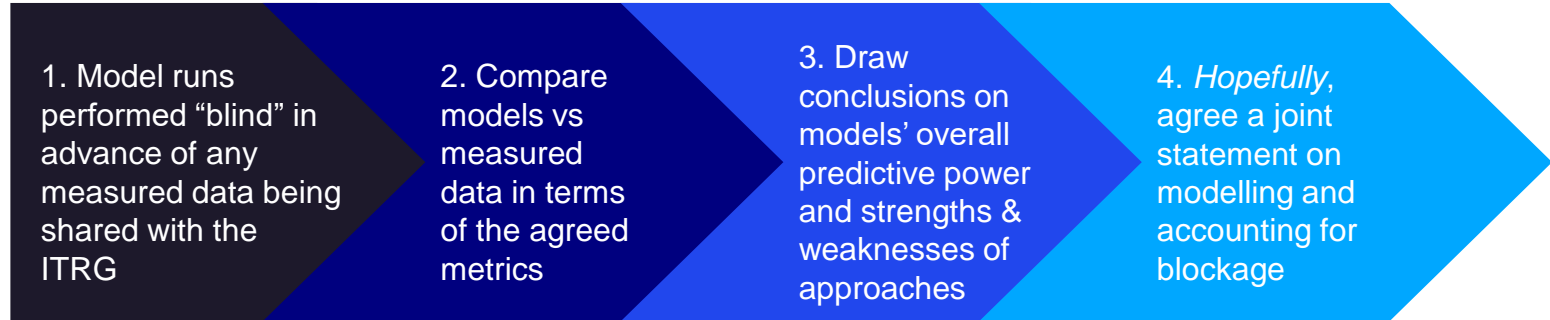

Project will conclude by end of November 2023

Acknowledgements

GloBE Project Partners:



Public Funders (X-Wakes and AFFABLE):



GloBE Delivery Partners:



ITRG:



Panel Q&A

carbontrust.com

