

## PID Controllers for BLDC Motor: A Comparative Study

Umesh Govardhane<sup>1</sup>, Prathamesh Mule<sup>2</sup>, Sakshi Lokhande<sup>3</sup>, Shraddha Jadhav<sup>4</sup>,  
Dhawal Tagare<sup>5</sup>, Ravindra Munje<sup>6\*</sup>

<sup>1,2,3,4</sup>Students, K.K. Wagh Institute of Engineering Education & Research, Nashik,  
Maharashtra, India

<sup>5</sup>Industry Guide, E-mmortal Automotives Pvt. Ltd. Nashik, Maharashtra, India

<sup>\*6</sup>Professor K.K. Wagh Institute of Engineering Education & Research, Nashik,  
Maharashtra, India

*\*Corresponding Author*

*E-Mail Id: rkmunje@kkwagh.edu.in*

### ABSTRACT

*Due to various environmental problems such as global warming, air pollution, and fossil fuels depletion, Electric Vehicles (EVs) are in more demand. Recently a lot of research is being done on the development of electric vehicles. The controller of an EV is considered as one of the most important parts as it controls the speed of the motor. Brushless DC motor (BLDC) has a great demand in EVs as it has a simple design, high applied output force (torque), long-term usage, and speed stability. While BLDC frameworks are portrayed by their vulnerabilities and non-linearity. As a result, controlling this motor is a significant concern. Similar to how a carburetor controls acceleration and speed in a gasoline-powered vehicle, the electronics package that controls the electric vehicle operates between the motor and the batteries. Engine regulators go about as the significant part which controls the energy stream to the engine. The motor controller processes commands from these inputs and precisely controls the speed, torque, direction, and horsepower of a vehicle motor by connecting interfaces like throttle, brakes, or forward/reverse control switches. BLDC engines can be subbed to make the enterprises more powerful. The Proportional Integral Derivative (PID) algorithm, which can more effectively improve the speed control of BLDC motors, is used in this paper to describe the design of the BLDC motor control system. The reason for the paper is to give an outline of the usefulness and plan of the PID regulator, for example recurrence reaction tuner and move capability tuner. At last, the review goes through a few well-working tests under various burden force conditions that will uphold that the PID controller is undeniably more relevant, better functional, and powerful in accomplishing good control execution contrasted with different regulators.*

**Keywords:** *BLDC motor, PID controller, frequency response tuner, transfer function tuner*

### INTRODUCTION

In the current scenario, mainly there exists a set of DC motors that are used for various applications. But in industrial applications, DC motors are generally set up as two types: the first type generates magnetic flux by passing current through the field coil of a static pole structure, while the second type is supplied with magnetic flux by permanent magnets. The brushless DC (BLDC) motor uses an

electronic process rather than a brush for transportation. It is usually a synchronous motor composed of a trapezoidal back EMF waveform and a permanent magnet. As the global industrial market becomes more efficient, BLDC motors are increasingly being used in electric vehicles as variable-speed drives. These motors are reliant on their control circuits to function properly. The control circuit of these types of motors is crucial, so developing one is a

challenging task. When compared with BLDC with a brushed DC motor, BLDC has several advantages. BLDC motor has overall higher efficiency also it has noiseless operation. The electric current is controlled by a computer; hence precise motor control can be obtained by BLDC.

For speed control of the BLDC motor using the sensor-based method, it is required for the controller to know the rotor position for electronic commutation. The sensor-based commutation method can be implemented in two ways, namely, an open loop system, and an enclosed system.

An open loop method does not track motor speed and therefore does not provide feedback. Instead, the PWM duty cycle is updated based on reference speed to control the motor speed. The advantages of this approach are a simpler control algorithm and lower cost. But as there is no way to track the actual motor speed accuracy cannot be maintained. In an enclosed system, the motor speed is tracked. So, the feedback mechanism is crucial. To control the motor speed, the PWM duty cycle is updated using both the reference speed and the actual speed. In comparison to open-loop control, this method has the advantage of system stability, minimal disturbances, and reduced sensitivity to dynamic load variations. Based on the requirements of the system, a P controller is a feedback controller, a PI controller is a feedforward controller, and a PID controller is a feedforward controller. For the speed control of BLDC motors, PID controllers are widely used as closed-loop feedback control systems. The P and PD controllers are directly proportional to the incoming error; therefore, even a small change in error can cause the system to become unstable. However, to reduce error to zero, the integral factor in a controller requires more iteration.

The design structure of BLDC is dependent on many factors like project selection, modeling, simulation, etc. In terms of the rapidity framework of the BLDC motor, a modern control solution has been proposed. The key features of conventional PID controller algorithms are it is easily adjustable, simple in design, and have a steady operation, which makes them widely used for controlling system. For practical reasons, a common speed control structure is applied in the PID controller.

In this paper, the speed control and mathematical model of the BLDC motor have been proposed and validated using the transfer function (TF) based tuner and the frequency response (FR) based tuner. For both the tuners, PI and PID controller parameters are determined. The representation of the PI and PID controller is also given in the form of a compensator formula. In a TF-based tuner, the system is linearized by linear system analysis and then the PI or PID controller parameters are determined. It is quite challenging, for tuning a PID controller to get the optimal position under the examined circumstances. This paper shows the proposed study of PID simulation for all four types of PID controllers namely FR-based PID, FR-based PI, TF-based PI, and TF-based PID controller by modifying some changes thereto which may develop the regulation speed of the BLDC motor. In such a case, parameters can be tuned at the actual moment under the PID control application.

The better functioning of the PID Controller scheme requires input and membership function enhancement. At the same time, a set of values is applied for the PID controller's constant coefficients  $k_p$ ,  $k_i$ , and  $k_d$ . By changing this value, the proposed modified version of the controller would be restructured to any adjusting dimension. The purpose of this

paper is to show the study of comparative rapid tuning results of the dynamic response of the modified PID controller such as FR-based PID, FR-based PI, TF-based PI, and TF-based PID respectively. The comparative study of how the controller helps in maintaining the constant speed during the load change and also controls the speed of the motor will be shown in this paper. Thus, the overall performance of the BLDC motor can be increased by using the PID controller. The simulation result shows the PID controller function for better control performance.

### LITERATURE REVIEW

The BLDC motor is a type of electric motor that has gained significant popularity in various industrial and consumer applications. Unlike traditional brushed DC motors, BLDC motors eliminate the need for brushes and commutators, resulting in improved reliability, efficiency, and performance [1]. The advancement in power electronics and control systems has further enhanced the widespread adoption of BLDC motors in numerous fields. The working principle of a BLDC motor involves the interaction between the stator and rotor components. The stator consists of multiple windings or coils, typically arranged in a three-phase configuration, producing a rotating magnetic field when supplied with electrical power.

The rotor, on the other hand, comprises permanent magnets or soft magnetic materials [2]. The operation of a BLDC motor relies on electronic commutation, where the motor's control system switches the current in the stator windings at precise moments to generate the required torque and rotational motion [3]. This electronic commutation is typically achieved using sensors, such as Hall effect sensors, or senseless techniques based on the measurement or estimation of the motor's back-EMF (electromotive force). BLDC

motors offer several advantages over traditional brushed motors. Firstly, the absence of brushes and commutators eliminates mechanical friction, resulting in reduced wear and maintenance requirements [4,5]. This attribute enhances the motor's lifespan and reliability, making BLDC motors suitable for applications where continuous operation is essential. Additionally, the absence of brushes also leads to lower electrical noise and reduced electromagnetic interference.

Furthermore, BLDC motors exhibit higher efficiency due to reduced power losses associated with brushes and commutation. This increased efficiency translates into improved energy consumption and reduced heat generation, making BLDC motors a preferred choice in applications where energy efficiency is crucial, such as electric vehicles, HVAC systems, and industrial automation. BLDC motors find applications in a wide range of industries, including automotive, robotics, aerospace, appliances, medical devices, and more [6]. Their compact size, high power density, and precise control capabilities make them ideal for various motion control systems.

In this literature review, we aim to explore the existing research and advancements in the design and development of speed controllers for BLDC motors. By reviewing the literature on different speed control techniques and associated challenges, we aim to gain insights into the speed control techniques using PI controller, and PID Controller. Also, gain insight into the frequency response tuner and transfer function tuner. Precise speed control is a critical requirement in many applications utilizing Brushless DC (BLDC) motors. To meet this demand, various speed control techniques have been developed and employed in the design and development of BLDC motor control systems. These techniques aim to regulate the motor's rotational speed,

ensuring optimal performance and efficiency across a wide range of operating conditions [8]. The various speed control techniques for BLDC motors are described as follows:

### Voltage Control

One of the fundamental speed control techniques for BLDC motors is voltage control. This technique involves adjusting the input voltage supplied to the motor to regulate its speed. By varying the voltage level, the motor's back-EMF (electromotive force) can be controlled, influencing the rotational speed. However, it's important to note that voltage control alone may not provide precise speed regulation, particularly under varying load conditions.

### Current Control

Current control techniques are widely employed in BLDC motor speed regulation. These techniques focus on regulating the motor's phase currents to achieve the desired speed. By adjusting the current waveform using methods like pulse-width modulation (PWM), the motor's speed can be effectively controlled. Current control techniques offer improved performance and stability compared to voltage control alone [9].

### Sensorless Control

Traditional BLDC motor control systems utilize position sensors, such as Hall effect sensors, to determine the rotor position and control the motor's speed. However,

sensorless control techniques have gained prominence due to their ability to eliminate the need for position sensors. Instead, sensorless control relies on measuring or estimating the motor's back-EMF to determine the rotor position and regulate the speed. Sensorless control provides cost savings, simplifies the motor system, and reduces potential failure points [10].

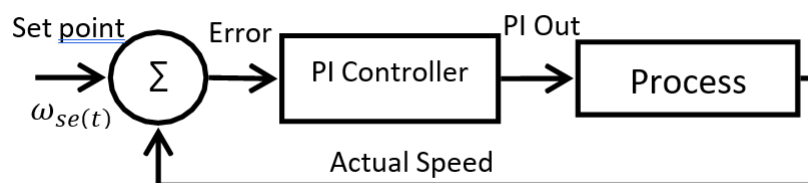
### Field-Oriented Control (FOC)

Field-Oriented Control, also known as vector control, is an advanced speed control technique for BLDC motors. FOC decouples the motor's magnetic flux and torque components, allowing independent control of these parameters. By accurately controlling the motor's magnetic field orientation and torque production, FOC achieves high-performance speed control [11]. This technique requires precise knowledge of the motor's parameters and typically utilizes rotor position sensors or sensorless methods [11].

### Direct Torque Control (DTC)

Direct Torque Control is another advanced control technique that directly regulates the motor's torque and flux. DTC employs a hysteresis-based control algorithm to control the motor's torque and speed rapidly and accurately. DTC offers excellent dynamic response and high torque control precision. However, it requires a comprehensive understanding of the motor's characteristics and may involve complex control algorithms.

### PI Controller



*Fig. 1: Block Diagram of PI Controller.*

The objective of any regulator is to limit the mistake between the genuine result, which should have been controlled, and the ideal result, which is known as the set

$$e(t) = \omega_{sp(t)} - \omega_{pv(t)} \quad (1)$$

where  $\omega_{sp(t)}$  is the reference speed or speed set point as a function of time,  $\omega_{pv(t)}$  is the actual motor speed as a function of time, and  $e(t)$  is the error function of time. The PI expression represents Relative Indispensable Subsidiary, so any PI regulator can be partitioned into 3 sections. T

he first part is the proportional part, which is the error multiplied by a constant gain,  $k_p$ . Each part has its own Gain. The PI controller equation can be expressed as follows, where  $e(t)$  is the error function of time,  $\omega_{sp(t)}$  is the reference speed or speed set point as a function of time, and  $\omega_{pv(t)}$  is the actual motor speed as a function of time. The second part is the integral part,

$$u(t) = k_p e(t) + k_I \int e(t) dt \quad (2)$$

where  $u(t)$  is the PI output,  $k_p$  is the proportional gain,  $k_I$  is the integral gain,  $k_D$  is the derivative gain, and  $e(t)$  is the error function shown in equation (1).

The control system ought to minimize four primary parameters:

- **Time to rise:** defined as the time required reaching 90% of the desired set point value **from 10%**.
- **Time to settle (Ts):** defined as the time it takes for the response curve to reach and maintain a range that is a

point. The following equation can be used to represent this error in the context of speed control.

which is the integration of error with time multiplied by a constant gain. The third part is the derivative part, which is the derivative of error with time multiplied by any PI controller can be broken down into three parts because the term "PI" stands for "Proportional Integral Derivative."

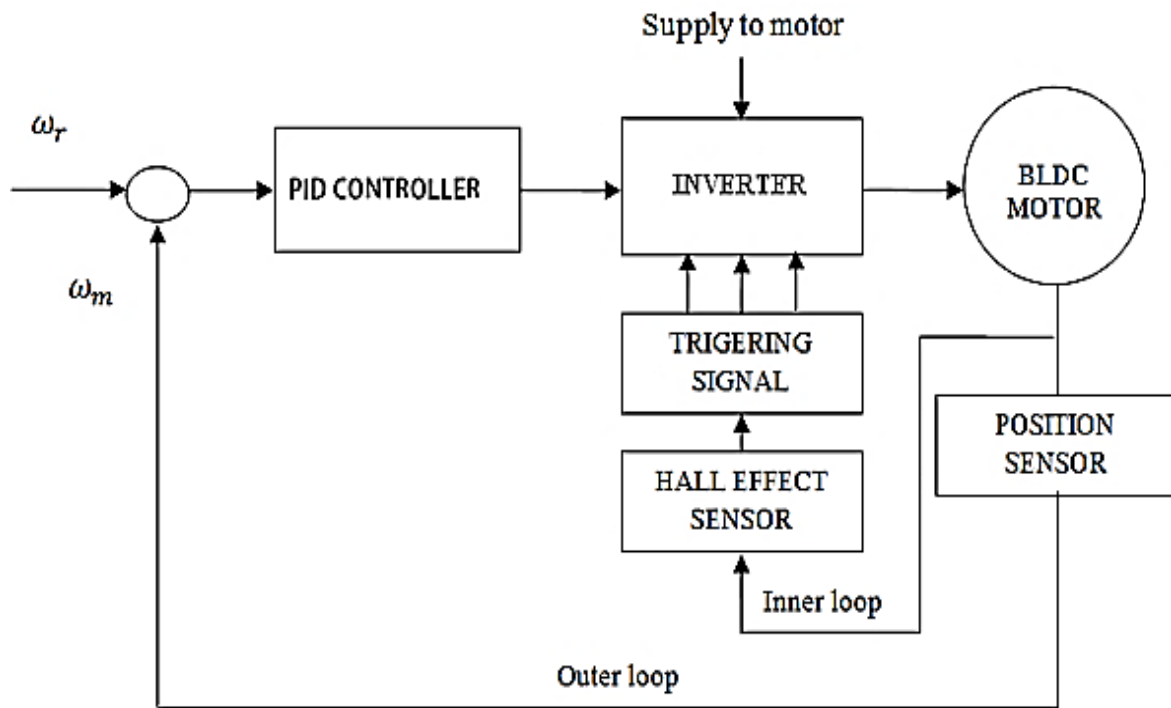
The first part is the proportional part, which is the error multiplied by a constant gain,  $k_p$ . Each part has its own Gain. The PI controller equation can be expressed as follows: The second part is the integral part, which is the integration of error with time multiplied by a constant gain, and the third part is the derivative part, which is the derivative of error with time multiplied by a constant gain,  $k_D$ .

certain percentage of the final value, typically 5% or 2%.

- **Steady-state error:** defined as the difference between the steady-state output and the desired output.
- **Overshooting:** defined as the maximum peak value of the response curve measured from the desired response of the system, Overshooting is the maximum value in the response curve minus the targeted value divided by the targeted value.



**PID Controller**



*Fig. 2: Block Diagram of BLDC Motor Speed Control.*

A BLDC motor speed controller block diagram utilizing two closed-loop systems is depicted in Figure 2. The speed is controlled by the external loop, and the power supply polarity is tuned and sensed by the internal loop in this instance. The motor speed controller assists in adjusting the DC bus's voltage. A DC supply is required to control the system, and its value is determined by the motor's rpm and capacity. A PID controller is used to control the inverter output voltage because this system also needs a controller. A sensor is a vital piece of a shut circle regulator for controlling the speed of an engine. The sensor's primary function is to provide the controller circuit with an equivalent electrical signal by converting the motor shaft's actual position and condition. An inverter circuit is used to convert the DC power supply voltage into an equivalent AC supply voltage for proper function because BLDC motors typically require an AC-like voltage waveform for operation [8, 9].

Frequency response tuner: The speed controller for a BLDC motor typically consists of a feedback control loop that adjusts the motor's drive signals based on the desired speed and the actual speed feedback from sensors. The objective is to maintain the motor speed at the desired setpoint while minimizing errors and disturbances. The frequency response tuner is used to measure and analyze the frequency response of the motor control system. This involves injecting test signals at different frequencies into the system and observing the output signals to determine how the system responds to different frequencies.

By analyzing the frequency response, engineers can identify the system's gain and phase characteristics, resonance frequencies, stability margins, and other important parameters. This information is crucial for designing and tuning the control loop to achieve stable and responsive motor control.

Transfer function tuner: In the design of a speed controller for a Brushless DC (BLDC) motor, a transfer function tuner is a tool used to analyze and tune the transfer functions within the control system. It aids in designing a controller that achieves the desired performance and stability characteristics. The transfer function represents the relationship between the input and output signals of a system in the frequency domain. In the context of a speed controller for a BLDC motor, the transfer function describes how changes in the control signal affect the motor speed.

### BLDC MOTOR MODEL DEVELOPMENT

The dynamic model of a BLDC motor can be divided into two parts: electrical and mechanical. The electrical model describes the motor's behavior in terms of its electrical properties, while the mechanical model describes its behavior in terms of its mechanical properties. The following are the models used in the dynamic modelling of BLDC motors: The voltage equations of the BLDC motor shown in Figure (1) are derived as,

$$v_{ab} = R(i_a - i_b) + L \frac{d}{dt} (i_a - i_b) + e_a - e_b, \quad (3)$$

$$v_{bc} = R(i_b - i_c) + L \frac{d}{dt} (i_b - i_c) + e_b - e_c, \quad (4)$$

$$v_{ca} = R(i_c - i_a) + L \frac{d}{dt} (i_c - i_a) + e_c - e_a, \quad (5)$$

where  $R$  – stator resistance per phase,  $L$  – stator inductance per phase,  $i_a$ ,  $i_b$  and  $i_c$  – instantaneous stator phase currents,  $V_{ab}$   $V_{bc}$   $V_{ca}$  – instantaneous stator line voltages,  $e_a$ ,  $e_b$  and  $e_c$  are instantaneous phase back – EMFs.

The current relationship is given by,

$$i_a + i_b + i_c = 0 \quad (6)$$

Equation (4) is rewritten as

$$i_c = -(i_a + i_b) \quad (7)$$

Substituting Equation (6) in Equation (3) and (4), one can get

$$v_{ab} = R(i_a - i_b) + L \frac{d}{dt} (i_a - i_b) + e_a + e_b \quad (8)$$

$$v_{bc} = R(i_a - 2i_b) + L \frac{d}{dt} (i_a + 2i_b) + e_b - e_c \quad (9)$$

The back EMF depends on the flux of the permanent magnet rotor and the speed of the rotor, which is given as

$$\begin{bmatrix} e_a \\ e_b \\ e_c \end{bmatrix} = \frac{K_e W_m}{2} \begin{bmatrix} F(\theta_e) \\ F(\theta_e - \frac{2\pi}{3}) \\ F(\theta_e - \frac{4\pi}{3}) \end{bmatrix} \quad (10)$$

The generated electromagnetic torque is given by Equation (9)

$$T_e = \left[ \frac{K_t}{2} F(\theta_e) i_a + \frac{K_t}{2} F\left(\theta_e - \frac{2\pi}{3}\right) i_b + \frac{K_t}{2} F\left(\theta_e - \frac{4\pi}{3}\right) i_c \right] \quad (11)$$

The dynamics of the motor and load are expressed as

$$T_e = K_f W_m + J \frac{d}{dt}(w_m) + T_L \quad (12)$$

$$T_e - T_L = K_f W_m + \frac{d}{dt}(W_m) \quad (13)$$

$$J \frac{d}{dt}(W_m) = T_e - T_L - K_f W_m \quad (14)$$

$$W'_m = -\frac{K_f}{J} W_m + \frac{1}{J}(T_e - T_L) \quad (15)$$

$$\theta_m = W_m \quad (16)$$

where,

$\theta_e = \frac{p}{2\theta}$  m electrical angle, degrees.

$w_m$  = rotor speed, rad/sec;

$k_e$  = back - emf constant, volts/rad/sec;

$J$  = moment of inertia, kg/m<sup>2</sup>.

$k_f$  = friction constant, Nm/rad/sec;

$T_L$  = load torque, N-m;

$k_t$  = torque constant, N-m

### Park Transformation

The Park transformation is used to transform the volt equation from the three-phase reference frame to the two-phase

reference frame. This transformation simplifies the mathematical analysis of the motor's behavior. The transformed equation is given by,

$$\begin{aligned} V_d &= V_{\cos} - V_{\sin} \\ V_q &= V_{\sin} + V_{\cos} \end{aligned}$$

where  $V_d$  and  $V_q$  are the two transformed voltages,  $V$  is the applied voltage, and  $\theta$  is the electrical angle.

### Clark Transformation

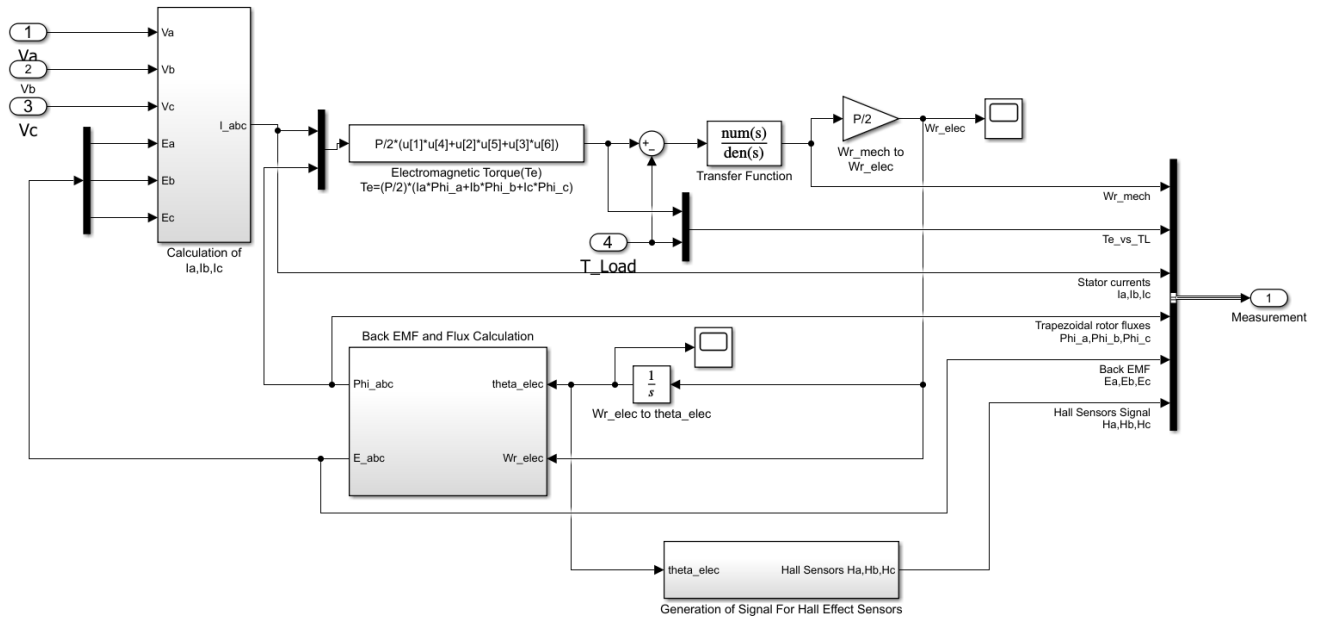
The Clark transformation is used to transform the two-phase reference frame into the stationary reference frame. This

transformation simplifies the control algorithms for the motor. The transformed equation is given by:

$$\begin{aligned} V_d &= V_d \\ V_b &= \frac{(-V_d + \sqrt{V_q})}{2} \\ V_c &= \frac{(-V_d - \sqrt{V_q})}{2} \end{aligned}$$

where  $V_a$ ,  $V_b$  and  $V_c$  are the transformed voltages in the stationary reference frame.





**Fig. 3: BLDC Motor Model.**

In Figure 3 BLDC motor model is shown.

**Table 1: Specification of motor.**

Parameters	Values
Resistance	2.875 $\Omega$
Inductance	8.3e-3 H
Rotor Flux	0.2158 Wb
Friction Coefficient -B	0.005
Rotor Inertia	0.089 Kg-m <sup>2</sup>
Pole pairs	4

Dynamic modelling of BLDC motors is essential in understanding and analyzing their behavior under various operating conditions. The electrical and mechanical models of BLDC motors help in simulating their behavior and predicting their performance. The parameters used for the simulation are given in Table 1.

**PID CONTROLLER DESIGN**

In this section, the PID controllers are designed for the BLDC motor. The PID controllers are obtained using automatic tuning using MATLAB. MATLAB has an in-built command to tune the PID controller parameters. The representation of the same is shown in Figure 4. The tuner block represents section options for continuous or discrete-time systems, the

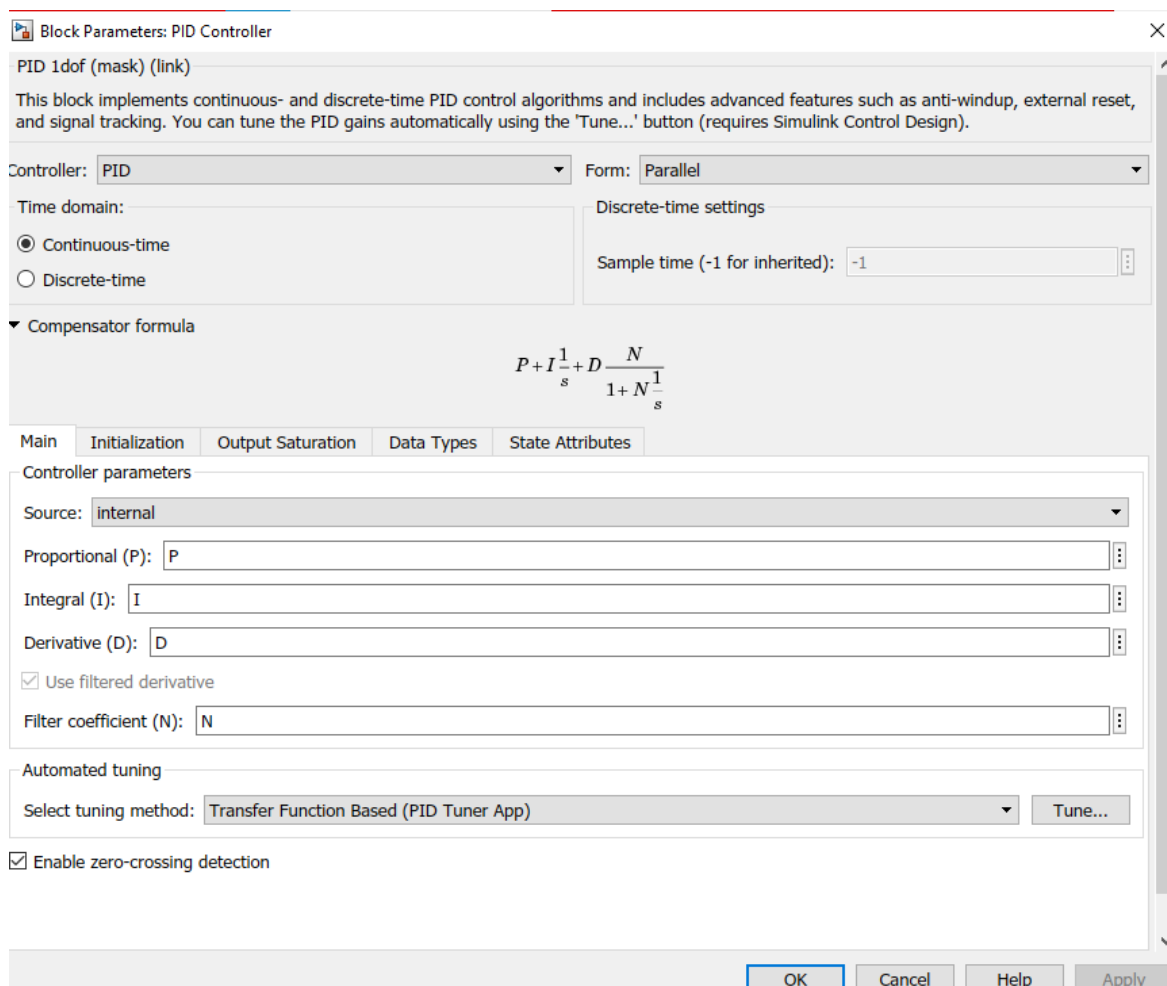
type of PID controller, *i.e.* parallel or ideal PID, and the option to select the tuning method. There are two options available for this. The first one is a transfer function (TF) based tuner and the second is a frequency response (FR) based tuner. For both the tuners, PI and PID controller parameters are determined. The representation of the PID controller is also given in the form of a compensator formula. In a TF-based tuner, the system is linearized by linear system analysis and then the PI or PID controller parameters are determined. After successful tuning, MATLAB shows the closed-loop response of the system and also provides the provision for the adjustment of the response by varying the aggression. One can decide the parameters based on the

requirement of the system. The representation of the same is shown in Figure 5. In an FR-based tuner, the controller parameters are obtained by obtaining the frequency response of the system. There is a provision to set the frequency response specifications and

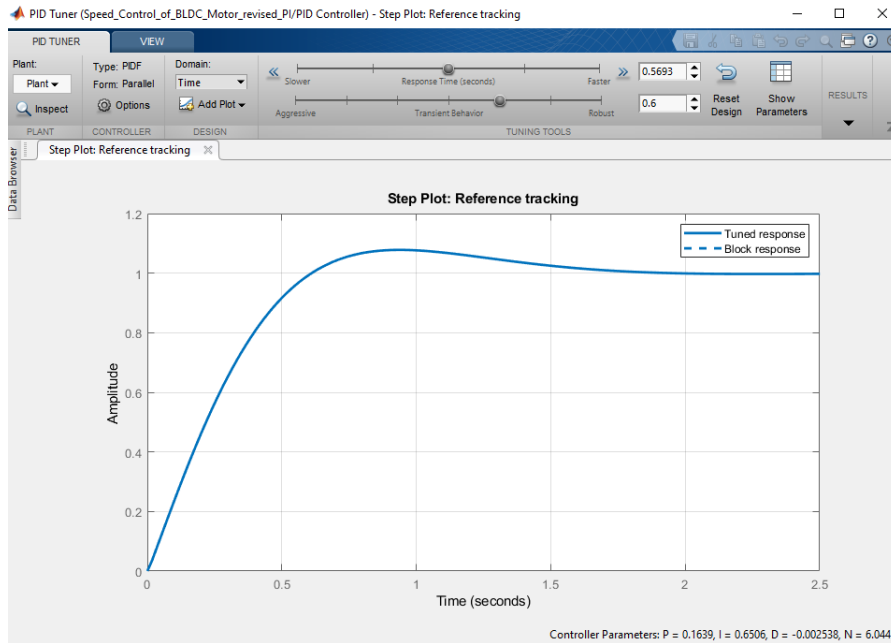
based on that the controller parameters are indicated. For the system of the BLDC motor, it was decided to have an overshoot of less than 20 % and a settling time below 5 seconds. Based on that, the parameters are obtained as follows.

**Table 2: Parameters of the PID Tuners.**

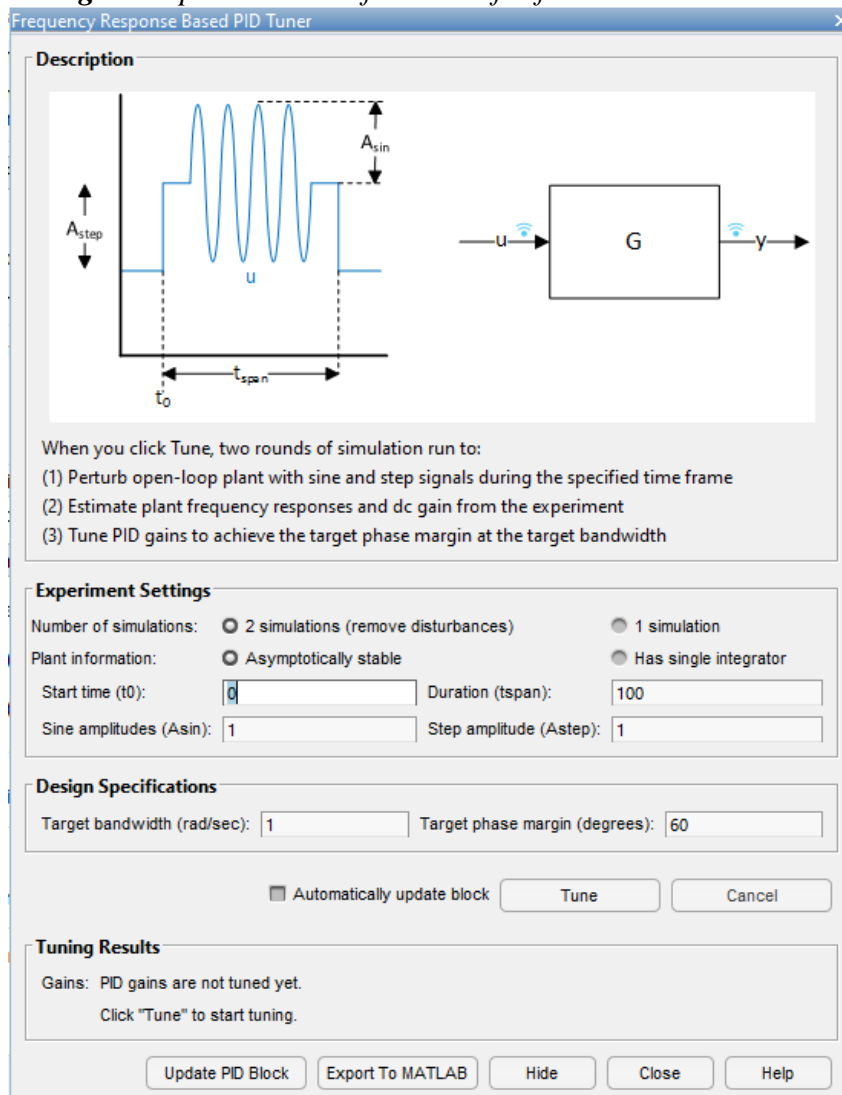
Parameters	TF Based Tuner		FR Based Tuner	
	PI	PID	PI	PID
P	0.1281	0.1639	0.009419	0.005802
I	0.7536	0.6506	0.191134	0.190189
D	--	-0.002538	--	0.002402
N	--	6.044	--	3



**Fig. 4: PID tuner in MATLAB.**



*Fig. 5: Representation of the transfer function-based tuner.*



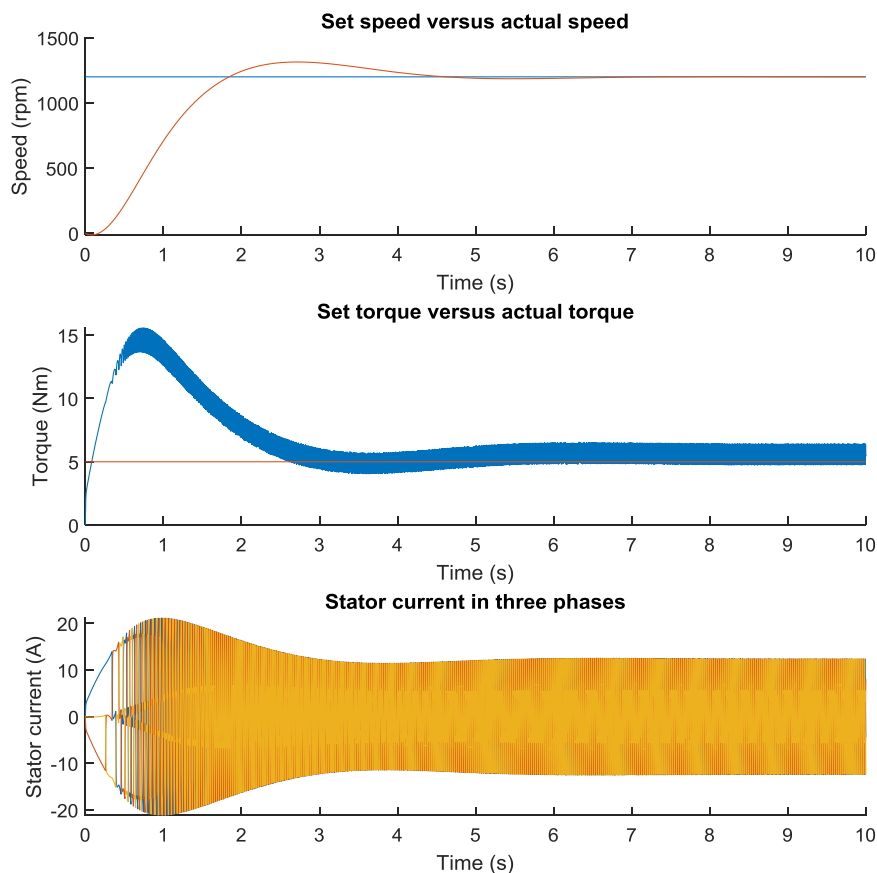
*Fig. 6: Representation of the frequency response-based tuner.*

### SIMULATION RESULTS

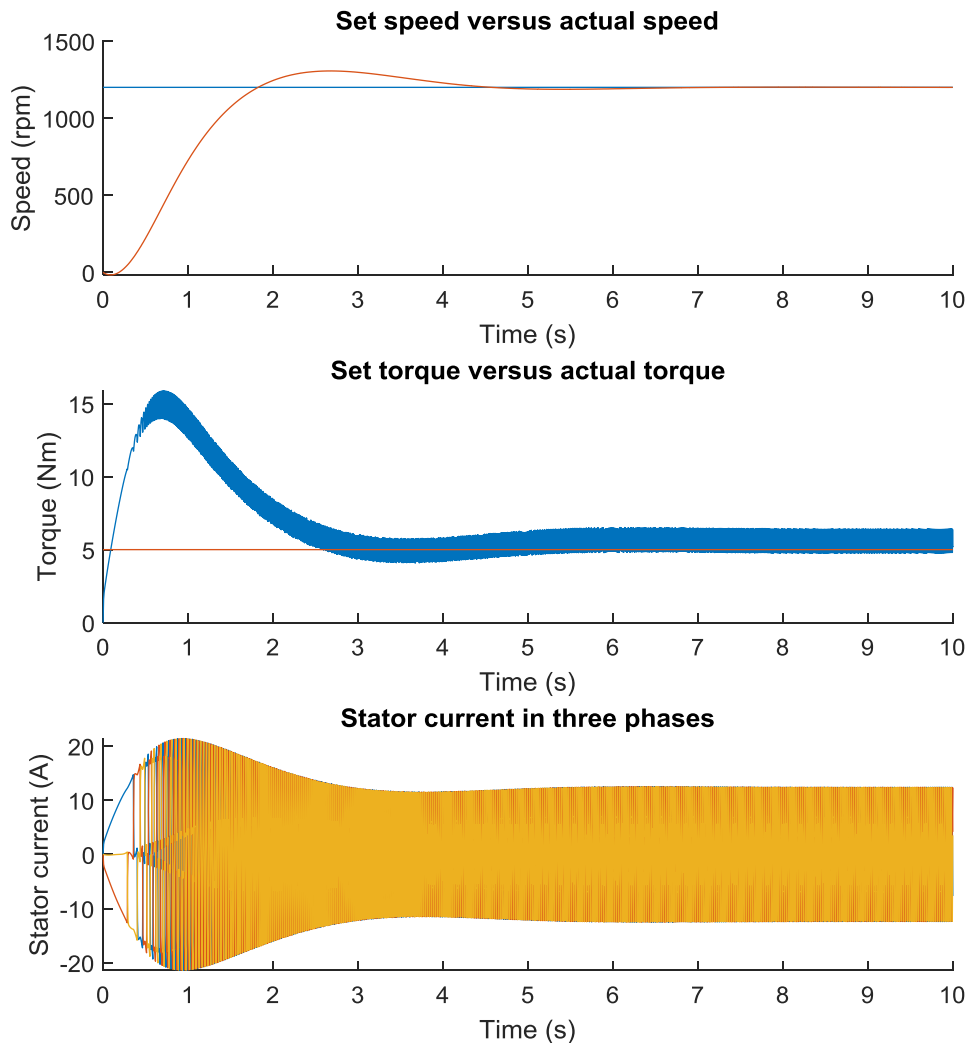
In this section, simulation results are presented for the three types of cases. The first case is about the step input, the second case is about the load torque disturbance and the third case is about the step change in the reference. All these cases are simulated for all four types of PID controllers, namely FR-based PID, FR-based PI, TF-based PI, and TF-based PID respectively.

Let us consider the FR-based PID controller. In the first case, the motor is started from zero speed and the speed is taken to 1200 rpm. For the corresponding change in the speed, the changes in the

torque and stator current are also observed. All these are given in Figure 7. In the first graph of Figure 5, speed is given with respect to the reference speed. It is seen that the steady state speed is achieved in 4 seconds. In the second graph of Figure 7, a load torque comparison is given with respect to the reference. The reference is set at 5 Nm. It is noticed that the desired torque is achieved in 3 seconds. The response of the torque is observed to have a ripple. The maximum value attended by the torque is around 15 Nm, which is within permissible limits. Finally, in the third graph of Figure 9, the stator currents are presented. The current is around 11 A. The initial current is about 20 A. This is also within the permissible limits.



**Fig. 7:** Frequency response based PID Tuner response for step input.



**Fig. 8:** Frequency response based PI Tuner response for a step input.

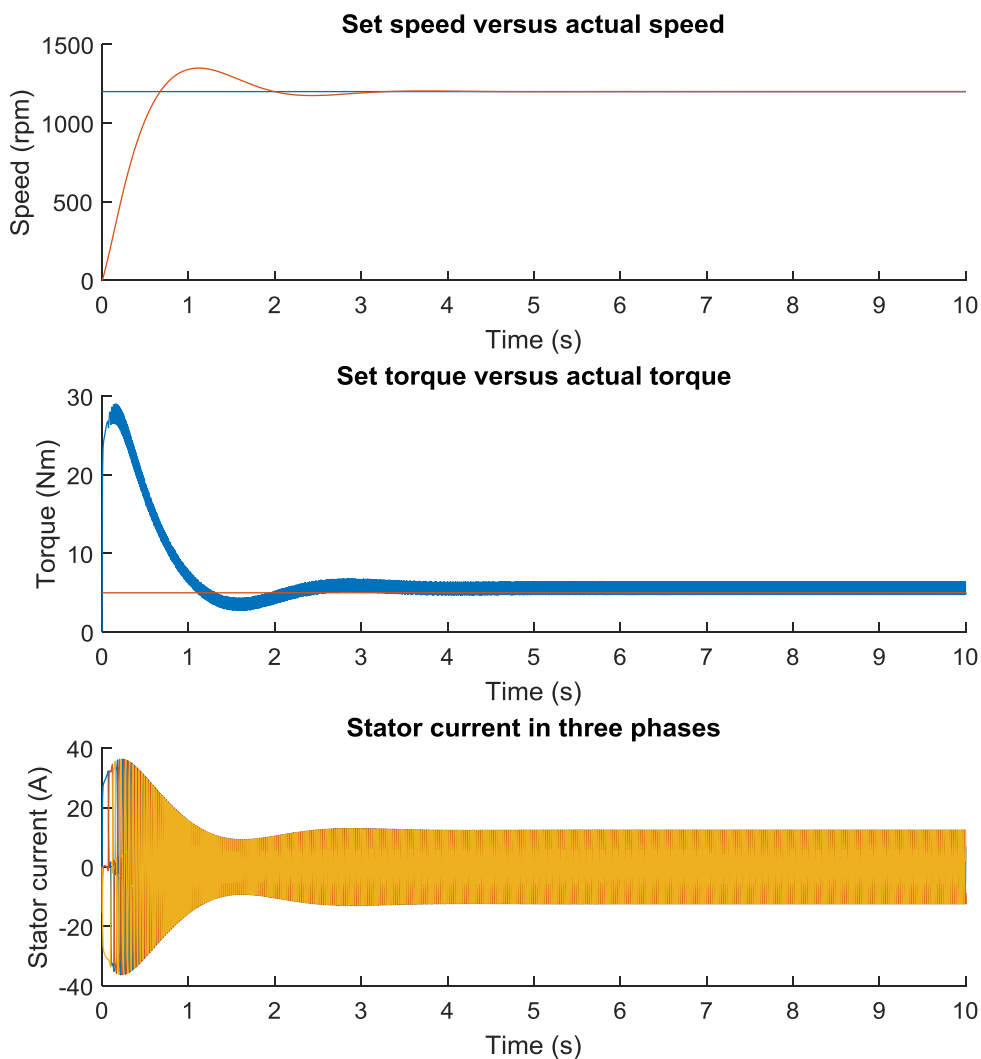
Now let us consider the case of FR-based PI controller. The simulations are shown in Figure 8. In the first case, the motor is again started from zero speed and the speed is taken to 1200 rpm. For the corresponding change in the speed, the changes in the torque and stator current are also observed. All these are given in Figure 10. In the first graph of Figure 10, speed is given with respect to the reference speed. Here also, it is seen that the steady state speed is achieved in 4 seconds. In the second graph of Figure 10, a load torque comparison is given with respect to the reference. The reference is set at 5 Nm. It is noticed that the desired torque is

achieved in 3 seconds. The maximum value attended by the torque is around 15 Nm, which is within permissible limits. Finally, in the third graph of Figure 9, the stator currents are presented. The current is around 11 A. The initial current is about 20 A. This is also within the permissible limits. The responses of FR-based PID and FR-based PI are found to be the same for all the variables.

Further, consider the case of the TF-based PI controller. The simulations are shown in Figure 9. The motor is again started from zero speed to 1200 rpm. For the corresponding change in the speed, the

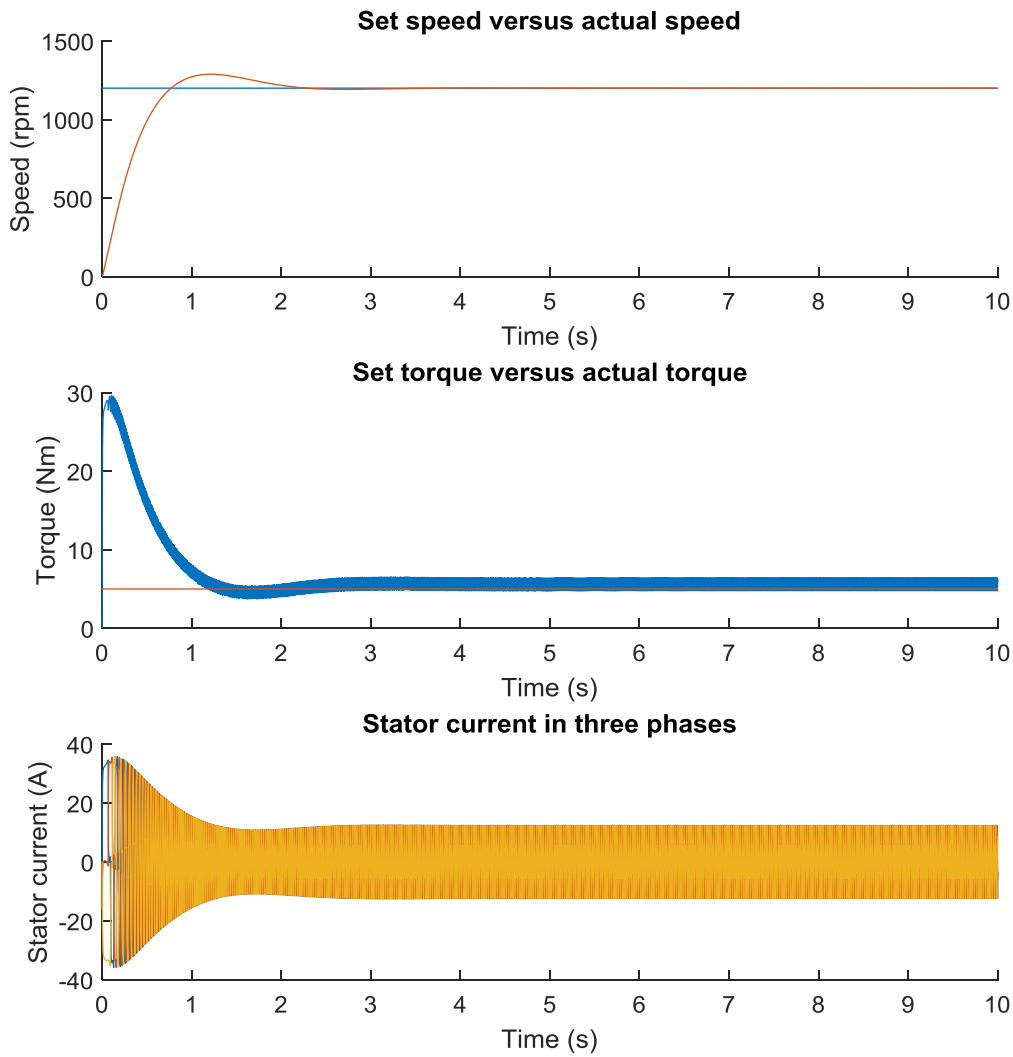
torque and stator current are also recorded in Figure 9. In the first graph of Figure 9, speed is shown with respect to the reference speed. It is seen that the steady state speed is achieved in less than 2 seconds. In the second graph of Figure 9, a load torque comparison is given with respect to the reference. The reference is set at 5 Nm. It is noticed that the desired

torque is achieved in 2 seconds. The maximum value attended by the torque is around 30 Nm, which is within permissible limits, but greater than FR-based PI and PID controllers. Finally, in the third graph of Figure 9, the stator currents are presented. The current is around 11 A. The initial current is about 40 A. This is also more than earlier PID controllers.

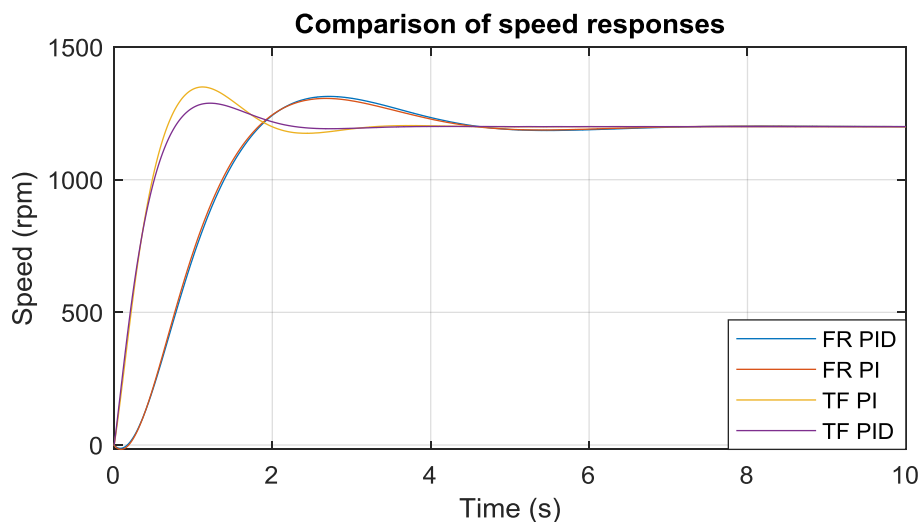


*Fig. 9: Transfer Function-based PI Tuner for a step input.*





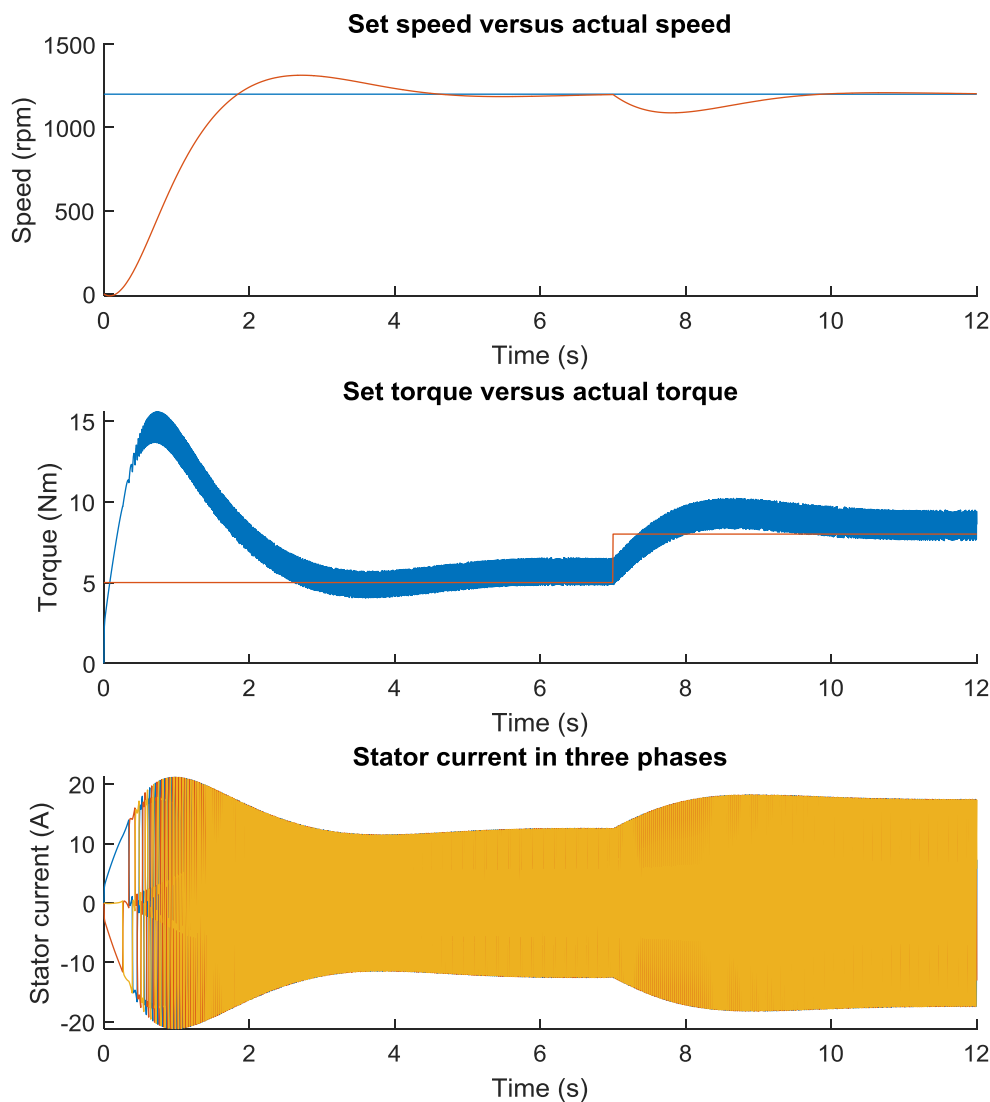
*Fig. 10: Transfer Function-based PID Tuner for a step input*



*Fig. 11: Comparison of the step responses.*

Finally, consider the case of the TF-based PID controller. The simulations are shown in Figure 10. The response is a little similar to the response due to the TF-based PI controller with reduced overshoot. The maximum values of torque and current are the same. To have a comparative analysis of all four PID controllers, the step

responses are shown in Figure 11. Here one can clearly observe the difference between the PID controllers. It is seen that the response due to TF-based PID is better than all PID controllers. However, the maximum values of torque and stator current are higher than almost 50%.



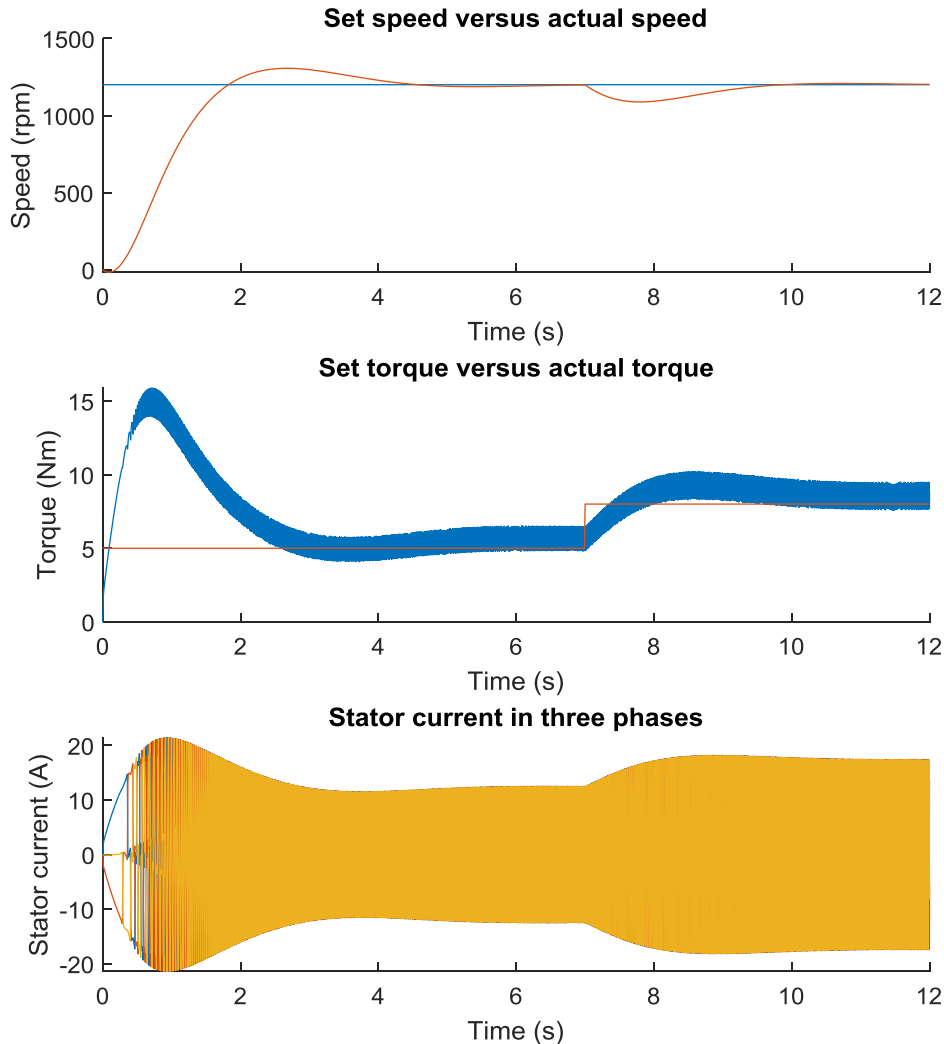
**Fig. 12:** Frequency Response based PID Tuner for the load disturbance.

Let us consider the case of load torque disturbance under a steady state. In this, the load torque is changed to 8 Nm at 7 seconds. This is then applied to all types of PID controllers. The results are shown in

Figures 12-15. As the controller is designed for the regulation speed, it is found that the speed is maintained at the desired value of 1200 rpm. This is compensated by increasing the value of the

current. All the variations in torque and stator currents are shown the Figures 12-15 for all types of controllers. Here also, it is

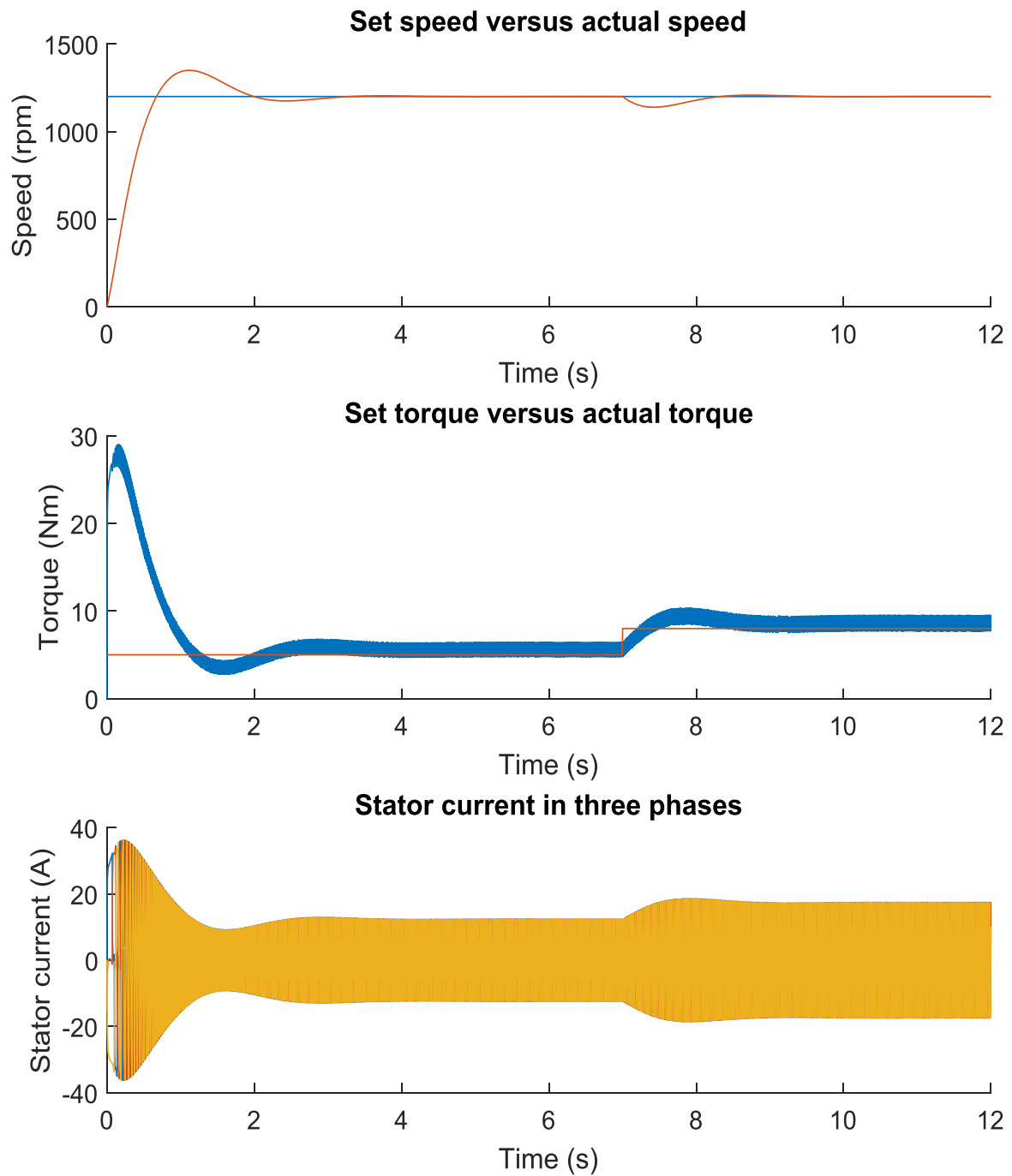
found that the response of the TF-based PID is better than all other controllers.



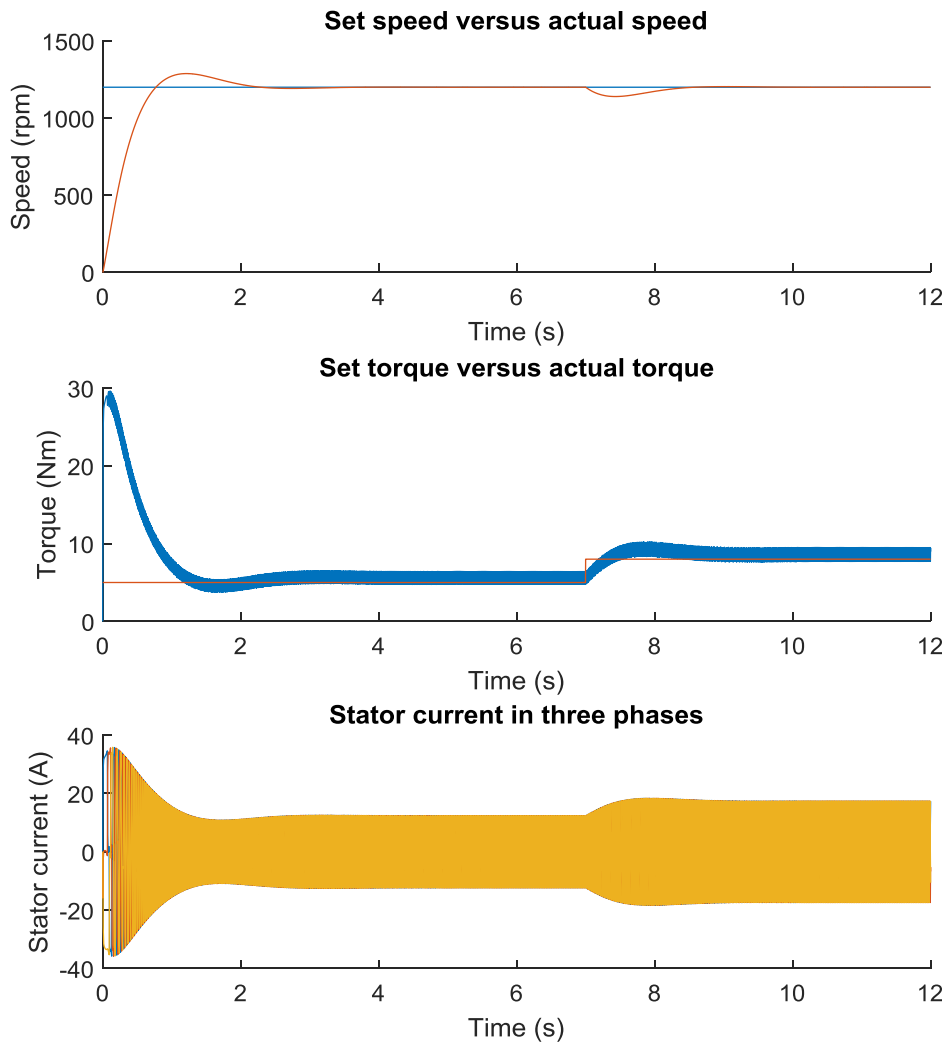
**Fig. 13:** Frequency Response based PI Tuner for the load disturbance.

FR-based PI and PID controllers were observed to have a similar response. One more observation is seen here the step response shows an inverse response at the beginning. Refereeing to the responses of TF-based PI and PID controllers, the ripples in the torque are found to be less than FR-based PI and PID controllers.

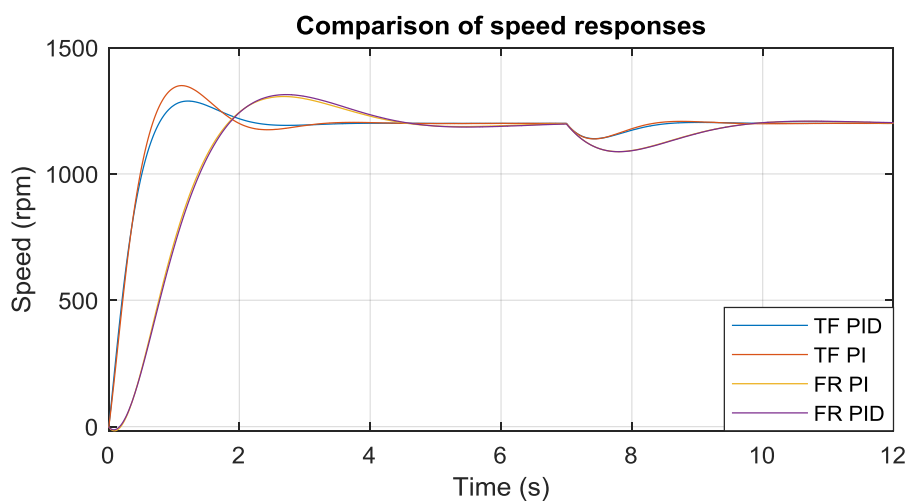
Again, the comparative result of the load torque disturbance is shown in Figure 14. In this, it is noticed that the response due to TF-based PID is superior to all other PID controllers.



*Fig. 14: Transfer Function based PI Tuner for the load disturbance.*



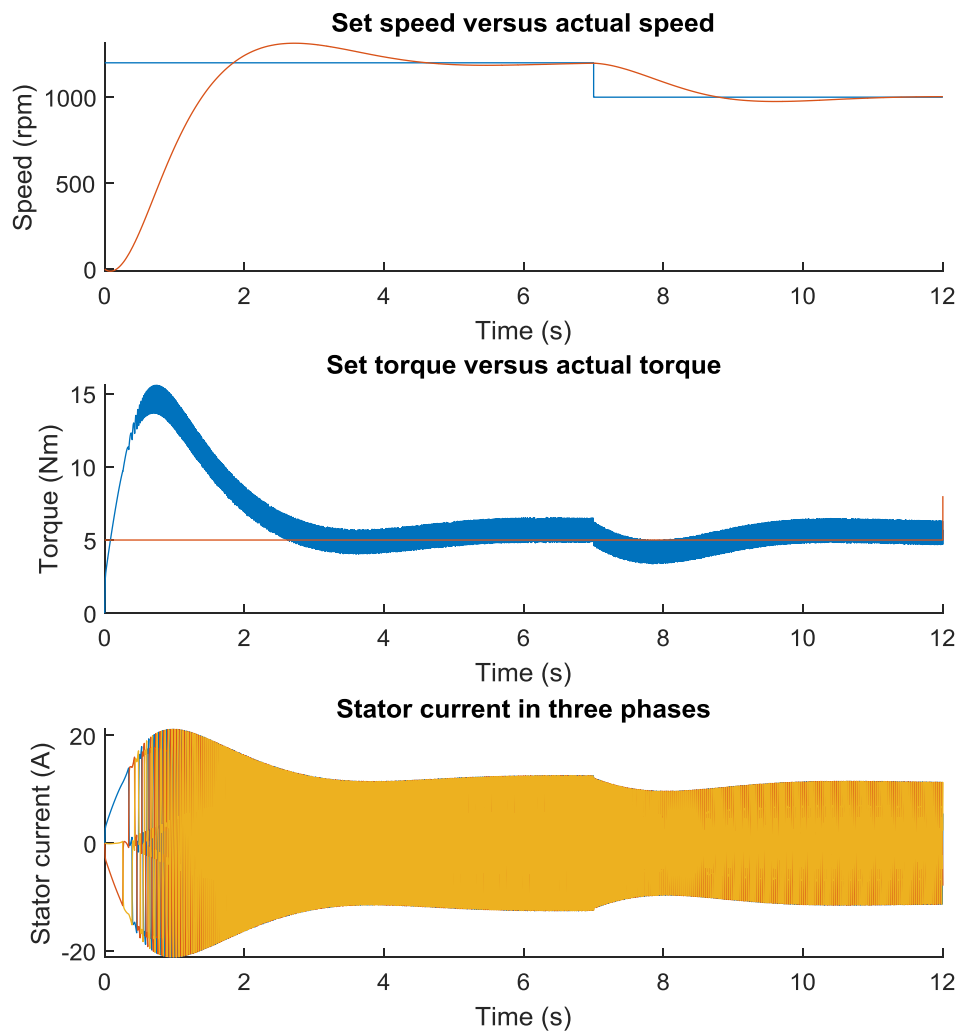
**Fig. 15:** Transfer Function based PID Tuner for the load disturbance.



**Fig. 16:** Comparison of PID controllers for the load disturbance.

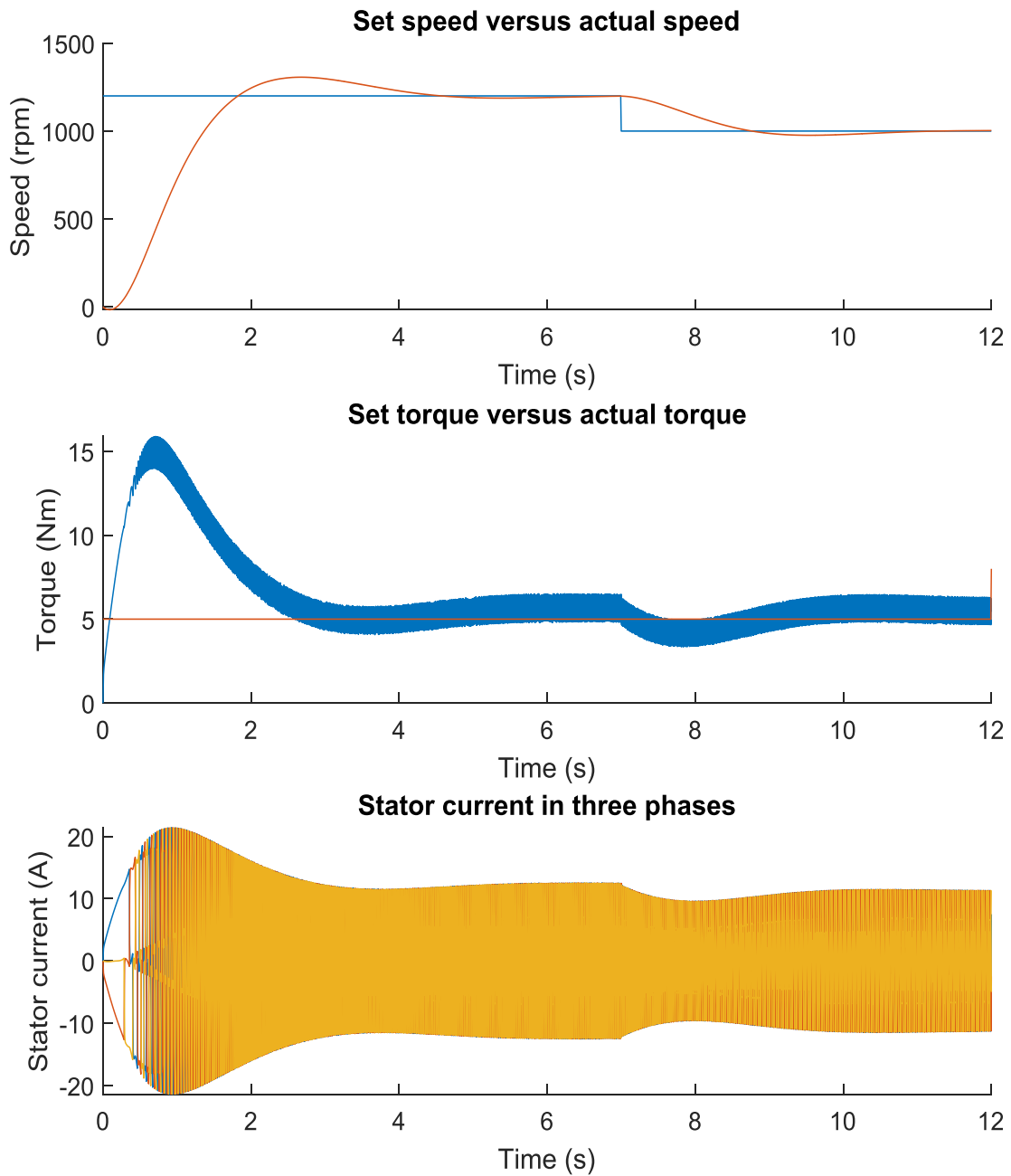
In the last case of simulation the step signal, i.e. the speed is changed after 7 seconds. In this, the load torque is maintained constant at 5 Nm. Again the simulation results are obtained with all four types of PID controllers are shown in Figures 17-20.

Figure 19 shows the response with an FR-based PID controller. It is observed that the speed shows variations when the step change is introduced. It takes the same time for settling as taken for the first time. Also, the torque shows variations for the step change in speed and then settles down. As speed is decreased the stator current requirement is also decreased.



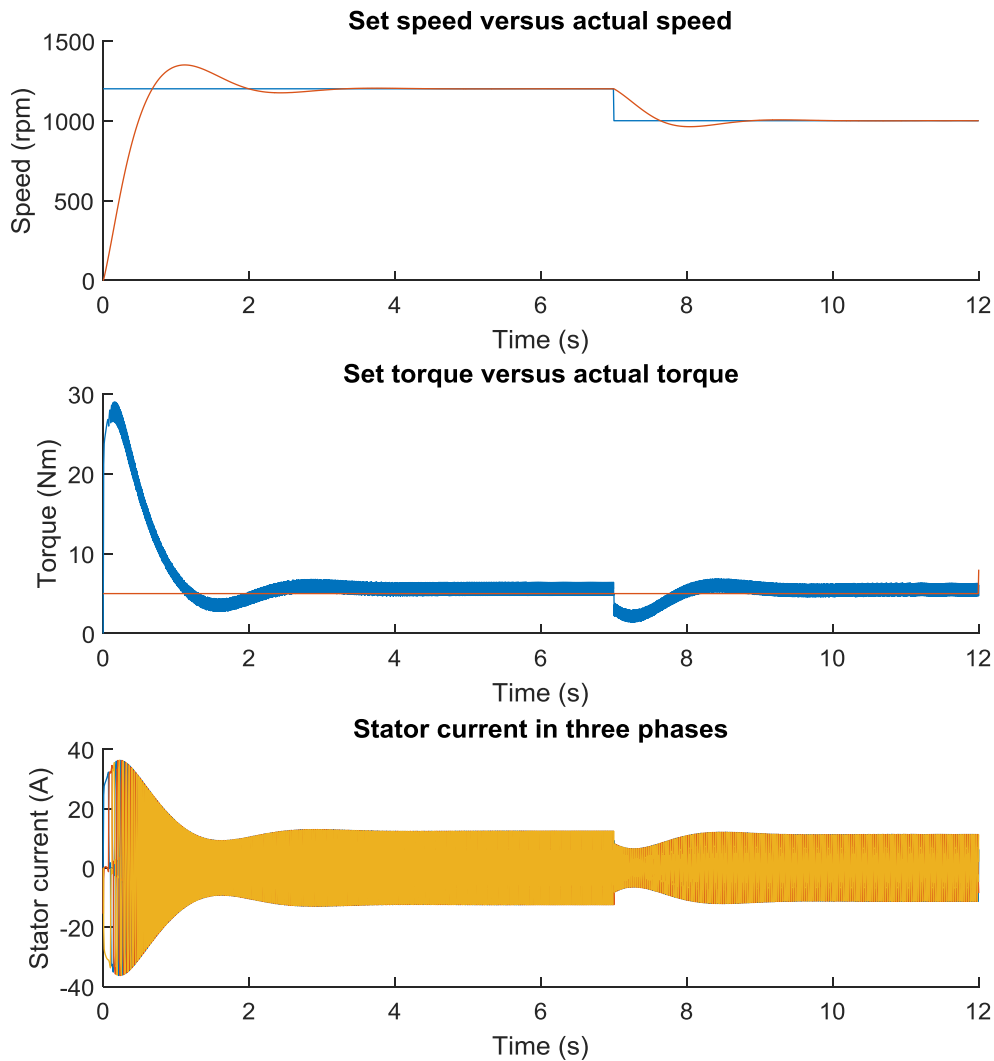
*Fig. 17: Frequency Response-based PID Tuner for the set point change.*





**Fig. 18:** Frequency Response-based PI Tuner for the set point change.

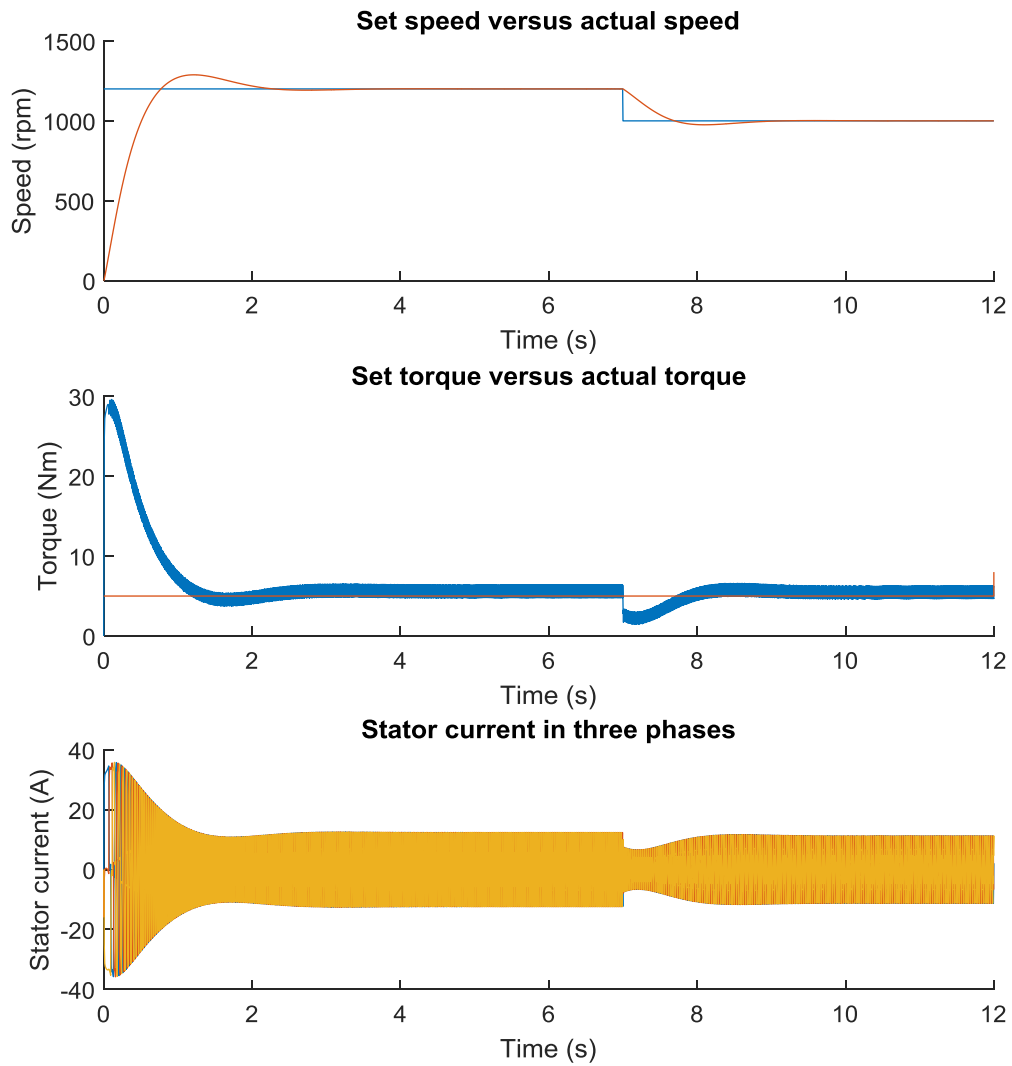
Similar kinds of results are obtained with RF-based PI controllers as shown in Figure 20. Further, Figures 21 and 22 show responses for the TF-based PI and PID controllers.



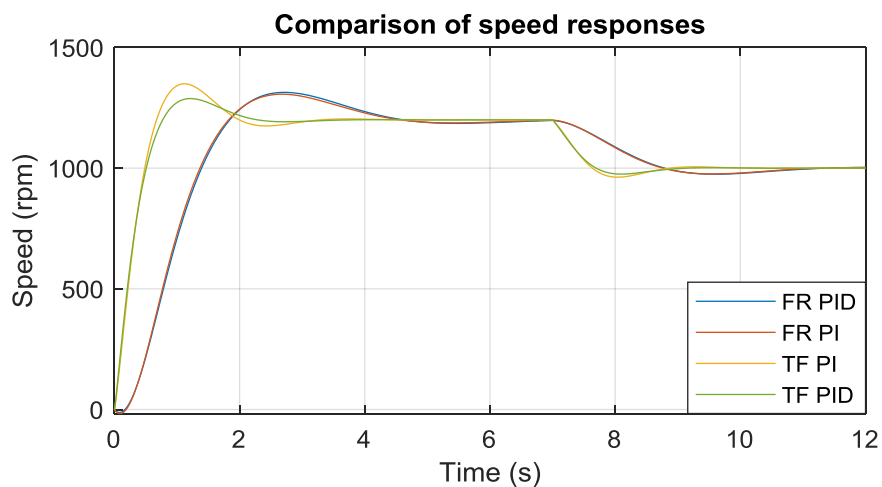
**Fig. 19:** Transfer Function-based PI Tuner for the set point change.

Figure 21 presents the comparison of the responses for speed change for all types of PID controllers. Considering all the cases of the simulations, namely, step input of speed, load torque disturbance, and step change in speed, it is noticed that, in all the

performance of the TF-based PID controller is better than all. However, the initial variations in the torque and current are observed to be more. But this can be controlled by adjusting the circuit.



*Fig. 20: Transfer Function-based PID Tuner for the set point change.*



*Fig. 21: Comparison of PID Tuners for the set point change.*

**CONCLUSION**

In this paper, various types of PID controllers are designed for the BLDC motor. We compared a total of four controllers. The comparative performances between Frequency response-based PI controller, Frequency response-based PID controller, Transfer Function response-based PI controller, and Transfer Function response-based PID controller are presented. We compared maximum overshoot, settling time, and peak time from all controllers. We concluded that for EV application Transfer function-based PID controller is best because all parameters of these controllers are in limit for application.

**REFERENCES**

1. Wang, T., Wang, H., Wang, C., & Hu, H. (2022). A novel PID controller for BLDCM speed control using dual fuzzy logic systems with HSA optimization. *Scientific Reports*, 12(1), 11316.
2. Mahmud, M., Motakabber, S. M. A., Alam, A. Z., & Nordin, A. N. (2020). Control BLDC motor speed using PID controller. *International Journal of Advanced Computer Science and Applications*, 11(3).
3. Walekar, V. R., & Murkute, S. V. (2018, August). Speed control of BLDC motor using PI & Fuzzy approach: a comparative study. In *2018 International Conference on Information, Communication, Engineering and Technology (ICICET)* (pp. 1-4). IEEE.
4. Suganthi, P., Nagapavithra, S., & Umamaheswari, S. (2017, March). Modeling and simulation of closed loop speed control for BLDC motor. In *2017 Conference on Emerging Devices and Smart Systems (ICEDSS)* (pp. 229-233). IEEE.
5. Hameed, H. S. (2018, January). Brushless DC motor controller design using MATLAB applications. In *2018 1st International Scientific Conference of Engineering Sciences-3rd Scientific Conference of Engineering Science (ISCES)* (pp. 44-49). IEEE.
6. Gujjar, M. N., & Kumar, P. (2017, May). Comparative analysis of field oriented control of BLDC motor using SPWM and SVPWM techniques. In *2017 2nd IEEE International Conference on Recent Trends in Electronics, Information & Communication Technology (RTEICT)* (pp. 924-929). IEEE.
7. Khubalkar, S., Junghare, A., Aware, M., & Das, S. (2017). Modeling and control of a permanent-magnet brushless DC motor drive using a fractional order proportional-integral-derivative controller. *Turkish Journal of Electrical Engineering and Computer Sciences*, 25(5), 4223-4241.
8. Khan, M. R., Khan, A. A., & Ghazali, U. (2015). Speed control of DC motor under varying load using PID controller. *International Journal of Engineering (IJE)*, 9(3), 38-48.
9. Kushwah, M., & Patra, A. (2014). Tuning PID controller for speed control of DC motor using soft computing techniques-A review. *Advance in Electronic and Electric Engineering*, 4(2), 141-148.
10. Lazor, M., & Štulrajter, M. (2014, May). Modified field oriented control for smooth torque operation of a BLDC motor. In *2014 ELEKTRO* (pp. 180-185). IEEE.
11. Joice, C. S., Paranjothi, S. R., & Kumar, J. S. (2011, December). Practical implementation of four quadrant operation of three phase Brushless DC motor using dsPIC. In *2011 International conference on recent advancements in electrical, electronics and control engineering* (pp. 91-94). IEEE.

12. Varatharaju, V. M., Mathur, B. L., & Udhyakumar, K. (2010, September). Speed control of PMSBLDC motor using MATLAB/Simulink and effects of load and inertia changes. In *2010 International Conference on Mechanical and Electrical Technology* (pp. 543-548). IEEE..
13. Pillay, P., & Krishnan, R. (1989). Modeling, simulation, and analysis of permanent-magnet motor drives. I. The permanent-magnet synchronous motor drive. *IEEE Transactions on industry applications*, 25(2), 265-273.
14. Baldursson, S. (2005). BLDC Motor Modelling and Control—A Matlab®. Simulink® Implementation *Raspoloživo na: <http://webfiles.chalmers.se/et/MSc/BaldurssonStefanMSc.pdf> [pristupljeno: 1. lipnja 2017].*