

# The **URBAN CONCRETE** Innovation



© 2023, “The Urban Concrete Innovation”  
Edited by Stijn Matthys, Syamak Tavasoli, Kathy Bouwheer

ISBN 9789082526851

D/2023/15076/02

DOI 10.5281/zenodo.7852852



This work is licensed under a Creative Commons Attribution-NonCommercial-ShareAlike 4.0 International License (CC BY-NC-SA 4.0). The policy of this license is specified at <https://creativecommons.org/licenses/by-nc-sa/4.0/>

This work contains information put forth in the framework of the EU projects URBCON and DuRSAAM. Reasonable efforts have been made to publish proper information, but the authors and editors cannot assume responsibility for the validity and accuracy of all materials or the consequences of their use. The authors and editors have attempted to avoid any copyright material or have get permission of the copyright holders and apologize to copyright holders if permission to publish in this form has not been properly obtained. If any copyright material has not been acknowledged, please contact us via the URBCON website so that we may rectify in any future version. Referenced figures or tables remain subject to copyright provisions associated to the copyright holders and are not licensed under this work.

# TABLE OF CONTENTS

Foreword.....	8
Contributors.....	10
Reading guide.....	12
1 Setting the scene .....	14
1.1 The motivation for urban concrete innovation .....	14
1.2 URBCON/DuRSAAM concrete technology .....	14
1.3 AAM concrete in brief .....	16
1.4 How this concrete technology fits circular & sustainable construction? .....	18
2 Avoiding primary raw materials and reducing the carbon footprint .....	20
2.1 Introduction.....	20
2.2 The binder part in concrete .....	21
2.2.1 Clinker based cement .....	22
2.2.2 Supplementary cementitious materials .....	26
2.2.3 Alkali-activated binders .....	28
2.3 The aggregates part in concrete .....	29
2.3.1 What are aggregates and going beyond natural aggregates.....	29
2.3.2 The aggregate industry in Europe.....	30
2.3.3 Aggregates from waste and demolished materials.....	30
2.4 By-products for use as construction minerals and their processing .....	40
2.4.1 Industrial waste and by-products .....	40
2.4.2 Biomass waste and by-products .....	49
3 Alkali-activated precursors as binder for eco-friendly concrete.....	51
3.1 Introduction.....	51
3.2 Chemistry of alkali-activated binders.....	51
3.3 Precursors for alkali-activation .....	55
3.3.1 Traditional precursors.....	55
3.3.2 Alternative precursors for alkali-activation (from waste sources).....	58
3.4 Activators for binders.....	62
3.4.1 Alkali hydroxides .....	63
3.4.2 Alkali-silicates.....	63

4	Performance based urbcon concrete .....	65
4.1	Introduction.....	65
4.2	AAM concrete mix.....	65
4.3	Fresh concrete behaviour .....	66
4.3.1	Influencing factors of fresh properties .....	66
4.3.2	Setting time.....	69
4.4	Hardened concrete behaviour .....	70
4.4.1	Influence of type of solid precursors .....	70
4.4.2	Influence of water to binder ratio .....	70
4.4.3	Influence of Na <sub>2</sub> O/binder ratio .....	71
4.4.4	Influence of SiO <sub>2</sub> /Na <sub>2</sub> O ratio .....	72
4.5	Durability of alkali-activated concrete .....	72
4.5.1	Carbonation .....	73
4.5.2	Chloride resistance .....	74
4.5.3	Sulphate resistance.....	75
4.5.4	Freeze–thaw resistance .....	77
4.5.5	Drying shrinkage .....	78
4.5.6	Alkali-silica reaction .....	80
5	Considerations for concrete practice and structural concrete .....	82
5.1	Introduction.....	82
5.2	Mix design robustness.....	83
5.2.1	Laboratory vs. industrial production .....	83
5.2.2	Influence of raw materials .....	83
5.2.3	Influence of temperature .....	83
5.2.4	Risk for rapid setting at industrial production.....	86
5.3	Dimensioning of load bearing elements using AAM concrete.....	86
5.3.1	Basis for design and dimensioning .....	86
5.3.2	AAM concrete properties to be tested as input for the design.....	87
5.3.3	Design check list for AAM concrete applications .....	88
5.3.4	Design by testing through proof load testing up to failure .....	88
5.4	Fibre reinforced alkali-activated concrete .....	91
5.4.1	Reducing the brittleness of plain concrete.....	91
5.4.2	Fibre reinforced alkali-activated concrete (FRAAC).....	92



5.4.3	Fibre reinforced high-performance alkali-activated concrete (FRHPAAC).....	93
5.4.4	Considerations toward real-life applications of FRAAC.....	95
5.5	AAM (textile) mortar to repair and strengthen structures.....	96
5.5.1	Mortars for structural repair and strengthening of concrete structures .....	96
5.5.2	Retrofitting of stone masonry structures .....	100
5.5.3	Retrofitting of concrete structures .....	102
6	Economic considerations.....	103
6.1	Introduction.....	103
6.2	Material costs.....	103
6.2.1	Traditional Concrete .....	103
6.2.2	AAM concrete .....	104
6.3	Price trends resulting from emissions trading considerations .....	105
6.4	Economic considerations with respect to energy consumption.....	106
6.5	Life cycle costing analysis .....	108
6.6	Market barriers .....	109
7	Environmental considerations.....	110
7.1	Introduction.....	110
7.2	What is life cycle assessment.....	110
7.3	LCA framework in reference to cement production.....	112
7.3.1	System boundaries.....	112
7.3.2	Description of the life cycle modules covered.....	113
7.3.3	Main impacts on the LCA of cement production.....	113
7.3.4	Emissions at the cement kiln .....	115
7.3.5	Provision of fossil fuels .....	115
7.3.6	Use of electricity .....	115
7.3.7	Co-product allocation .....	116
7.4	LCA framework in reference to concrete production.....	116
7.4.1	System boundaries.....	116
7.4.2	Description of the life cycle modules covered.....	117
7.4.3	Main impacts on the LCA of concrete production.....	117
7.5	LCA of URBCON/DuRSAAM AAM concretes .....	119
7.5.1	LCA of AAM reference mixes .....	119

7.5.2	LCA of URBCON concrete.....	123
7.6	Environmental considerations in terms of leaching .....	124
8	Circular transition and tendering .....	126
8.1	Introduction.....	126
8.2	Policy making towards circular transition .....	126
8.2.1	Setting the scene.....	126
8.2.2	Barriers.....	127
8.2.3	Policy recommendations .....	128
8.3	Tendering .....	129
8.3.1	Kamp C .....	130
8.3.2	City of Ghent .....	131
8.3.3	Municipality of Rotterdam.....	134
8.4	Lessons learned from the URBCON pilots.....	135
8.4.1	A way of documenting lessons learned from the demonstrators.....	135
8.4.2	Learnings from the Ghent pilot.....	136
8.4.3	Learnings from the Westerlo pilot.....	142
8.4.4	Learnings from the Rotterdam pilot .....	145
9	Applications .....	150
9.1	Introduction.....	150
9.2	Review of existing applications before the URBCON/DuRSAAM projects.....	150
9.2.1	Adoption of alkali-activated blast furnace slag concrete .....	150
9.2.2	Adoption of alkali-activated fly ash concretes.....	152
9.2.3	Wider adoption of alkali-activated concretes .....	153
9.3	URBCON demonstrator 1: pedestrian bridge in Rotterdam .....	155
9.3.1	Renewal of pedestrian bridge using URBCON concrete .....	155
9.3.2	Tender and support team .....	155
9.3.3	Mixture.....	156
9.3.4	Test protocol .....	157
9.3.5	Long term monitoring.....	159
9.3.6	Technical design.....	160
9.3.7	Construction phase .....	161
9.3.8	Knowledge gain for Rotterdam.....	168
9.4	URBCON demonstrator 2: fire escape staircase in Gent.....	168

9.4.1	Addition of fire escape staircase using URBCON concrete.....	168
9.4.2	Information on the development of the binder and mix design.....	171
9.4.3	Production and installation of the precast elements at Zonnepoort.....	172
9.4.4	Testing and long-term testing.....	175
9.4.5	Knowledge Gain for the city of Ghent .....	176
9.5	URBCON demonstrator 3: foundation of circular office building in Westerlo .....	176
9.5.1	URBCON concrete as part of a new circular office building .....	176
9.5.2	Production and installation of the foundation .....	177
9.5.3	Information on the development of the binder and mix design.....	178
9.5.4	Information on the dimensioning of the components .....	178
9.5.5	Information on the by-products used and their processing.....	179
9.5.6	Information on conducted quality control testing .....	179
9.5.7	Knowledge gain for the partners involved in ‘t Centrum .....	180
9.6	Street furniture in URBCON concrete technology .....	180
9.6.1	Historical case: reinforced concrete cantilever bench in Rotterdam.....	180
9.6.2	Architectural concrete bench in Gent.....	182
9.6.3	URBCON concrete family showcase bench in Westerlo.....	183
9.6.4	Inverted trough concrete bench in Kaiserslautern.....	184
10	About us.....	186
10.1	About URBCON.....	186
10.2	About DuRSAAM .....	187
10.3	Project partners.....	188
	References .....	190
	Index.....	215

## FOREWORD

Eco-friendly or circular concrete solutions are investigated widely in view of lowering environmental impact, while keeping the high technical performance expected from contemporary building solutions. This has also been the driving force behind the European sister projects, URBCON and DuRSAAM, which focus on 'cement and primary construction minerals free concrete', making use of alkali-activated materials. Where URBCON is focused on technology demonstration and reducing socio-economic hurdles, DuRSAAM trains highly skilled engineers in this technology and leaps forward the state-of-the art on this novel concrete technology.

You might wonder as a reader why it is important to start using more eco-friendly and circular concrete products in the built environment? Well, concrete is one of the most popular building materials, making it also of concern when considering the environmental impact of the construction sector and the associated built environment. For example, the construction sector is responsible for over 35% of the EU's waste generation, buildings account for 40% of energy consumed, construction activities require a vast number of resources and cement, being a major component of concrete, accounts for 5 to 8% of the carbon emissions. Although concrete performs quite well in terms of environmental impact compared to other construction materials, its wide use makes sustainability of concrete crucial in minimizing the environmental impact, as can be characterized from life cycle assessments.

The European Union is taking a lead in tackling climate change by the implementation of the 'Green Deal', an ambitious action plan to achieve the climate neutrality of the EU by 2050, among which the goal on zero greenhouse emissions by that time. This challenges construction companies, design engineers and all stakeholders involved, to act on durability, sustainability and life cycle assessment of buildings and infrastructure. Emerging solutions such as the URBCON/DuRSAAM concrete technology platform are of considerable importance in the framework of the Green Deal or similar visions and highlights the need for well-informed stakeholders in this contemporary concrete technology.

In this respect we are happy to provide you with this open access e-book 'The Urban Concrete Innovation', to:

- inform and guide citizens, landlords, building users, architects, engineers, contractors, governments, etc. about the URBCON/DuRSAAM concrete technology in such a way to be able to understand its benefits and technical soundness, and so to start using it;
- challenge and appeal on all stakeholders having eco-friendly concretes in mind as emerging building technology, to go ahead with practical implementations;
- steer the construction sector and society further towards a more sustainable built environment.

This book is the joint and highly acknowledged effort of 33 authors (see Section Contributors), member of both projects URBCON and DuRSAAM. Basic insights and more detailed information are



provided on eco-friendly concrete targeting to be free of traditional Portland cement and targeting to be free of primary resourced construction minerals, so to avoid using Earth, lower CO<sub>2</sub> impact and keep excellent technical performance. Examples of concrete compositions are provided, application and tendering aspects are discussed, practical applications are described by means of some historical and recent cases, ... and many more. We trust that you can learn a lot from this book and that it might help you to become actively involved into a more sustainable built environment.

**Stijn Matthys**, coordinator of DuRSAAM and technical coordinator of URBCON, editor

**Ann Bats**, coordinator of URBCON

**Syamak Tavasoli**, coordinator of the URBCON/DuRSAAM e-book, editor

**Kathy Bouwheer**, editor in chief

Gent, February 2023

# CONTRIBUTORS

**Stijn Matthys, Saeid Ghorbani, Ivana Krajnovic, Yubo Sun, Alessandro Proia**

Department of Structural Engineering and Building Materials  
Ghent University, Belgium

**Wolfgang Breit, Syamak Tavasoli, Sophie Burgmann**

Institute of Construction Material Technology  
University of Kaiserslautern-Landau (RPTU), Germany

**Guang Ye, Hua Dong, Luiz Miranda de Lima Junior**

Faculty of Civil Engineering and Geoscience  
Delft University of Technology, Netherlands

**John L. Provis, Laura Stefanini**

Department of Materials Science and Engineering  
University of Sheffield, UK

**Laura Rossi**

Institute of Building Materials and Concrete Structures (IMB)  
Karlsruhe Institute of Technology (KIT), Germany

**Anastasija Komkova**

Department of Sustainable Construction  
ETH Zurich, Switzerland

**Lazar Azdejković**

Department of Civil Engineering  
University of Patras, Greece

**Sebastian Palm, Jochen Reiners**

Concrete Technology Department  
VDZ Technology

**Wouter Crijns**

ResourceFull

**Birgitte Holt Andersen**

CWare

**Anton Deruwe, Gert De Beule, Eric De Coninck**

ArcelorMittal Belgium

**Deeba Ansari**

Imerys Minerals

**Ann Bats, Wouter Antheunis, Jean-Philippe Bertin**

City of Ghent

**William Schutte, Kees Blom, Joep van Leeuwen, Bouke Bakker**

Municipality of Rotterdam

**Marijke Aerts, Kelly Penen**

Kamp C

## READING GUIDE

Dear reader, this technology e-book is collecting latest insights in green future made concrete, based on alkali-activated concrete binder technology. The book has been written having the following 4 stakeholder groups in mind: 1. Public authorities/Landlords; 2. Architect/Engineers; 3. Construction companies; and 4. Citizens/students. This is just a general guideline. Find out what's in it for you and enjoy reading those parts of the book that interest you most.

### PUBLIC AUTHORITIES/LANDLORDS

---



CO<sub>2</sub>-reduction is a major part in our efforts to become climate-neutral. As a public authority or private/public landlord you can reduce CO<sub>2</sub>-pollution by adapting your tenders for small and larger construction sites. Let us explain how the free URBCON-technology can help you to make a green future concrete. Read all about it in this e-handbook.

- Do you want to know more about policy and tendering with respect to circular concrete? → go to page [126 \(Chapter 8\)](#)
- Are there already existing applications for inspiration? → go to page [150 \(Chapter 9\)](#)
- Do we really have an environmental gain? → go to page [110 \(Chapter 7\)](#)
- Do we really save natural materials from mother earth? → go to page [20 \(Chapter 2\)](#)
- What about cost considerations? → go to page [103 \(Chapter 6\)](#)
- What about technical performance? → go to page [65 \(Chapter 4\)](#)
- Do you want to know a bit more about the technology behind it and the practical implementation? → go to page [51 \(Chapter 3\)](#) and to page [82 \(Chapter 5\)](#)

### ARCHITECTS/ENGINEERS

---



As a professional in the building industry, you are certainly interested in a climate-resilient future. We from URBCON/DuRSAAM share the same concern. Therefore, we developed URBCON-concrete. A green future made concrete. URBCON reduces the use of raw materials and the CO<sub>2</sub>-emissions from construction and maintenance of buildings and infrastructure in cities. Do you want to learn more about this positive impact on our future? Find out in this e-handbook, sharing latest insights.

- Are there already existing applications for inspiration? → go to page [150 \(Chapter 9\)](#)
- What about cost considerations? → go to page [103 \(Chapter 6\)](#)
- What about technical performance? → go to page [65 \(Chapter 4\)](#)
- Do you want to know a bit more about the technology behind it → go to page [51 \(Chapter 3\)](#)
- How to deal with tendering of circular concrete? → go to page [126 \(Chapter 8\)](#)
- What are the environmental advantages? → go to page [110 \(Chapter 7\)](#)



## CONSTRUCTION COMPANIES

---



Energy-efficiency, environmentally friendly construction on a circular economy-basis. This is the service your customers are looking for. URBCON can help you to meet the demands of your customers. The URBCON-technology is the perfect example of a better, greener way of construction. URBCON is a way to save the use of raw materials and reduce CO<sub>2</sub>-emissions. Do you want to learn more about URBCON technology, read this e-handbook as follows.

- What is the technology behind it? → go to page [51 \(Chapter 3\)](#)
- What are considerations for concrete practice? → go to page [82 \(Chapter 5\)](#)
- How does it compare to traditional concrete in terms of technical performance? → go to page [65 \(Chapter 4\)](#)
- Are there already existing applications for inspiration? → go to page [150 \(Chapter 9\)](#)
- What about cost considerations? → go to page [103 \(Chapter 6\)](#)
- How is circular concrete requested by landlords in tenders? → go to page [126 \(Chapter 8\)](#)
- What are the environmental advantages? → go to page [110 \(Chapter 7\)](#)

## CITIZENS/STUDENTS

---



Concrete is the second most used material in the world after water. The production of cement, which is needed to make concrete, emits more CO<sub>2</sub> than aviation, shipping and road freight transport combined. Many new raw materials are also extracted for it. Many of those resources are running out. That is why we are developing a new type of concrete, called URBCON concrete. URBCON concrete consists of materials that emit less CO<sub>2</sub> and materials that have been used before. Read all about the URBCON concrete, that is based on alkali-activated concrete technology, in this e-handbook.

- Are there examples of existing applications on this technology? → go to page [150 \(Chapter 9\)](#)
- What is the technology behind it? → go to page [51 \(Chapter 3\)](#)
- Is this an expensive concrete technology? → go to page [103 \(Chapter 6\)](#)
- Do we really have an environmental gain and save natural materials from mother earth? → go to page [110 \(Chapter 7\)](#)

# 1 SETTING THE SCENE

## 1.1 The motivation for urban concrete innovation

Concrete is a popular and efficient building material. Considering different construction materials, the environmental footprint of concrete per material unit volume is amongst the best. However, being used that widely all over the world, its environmental impact sums up to large numbers. The upside of this observation is that when improving the environmental impact of concrete, significant gains can be made in terms of reducing carbon dioxide emissions and using less primary raw materials. This has been achieved with the developed URBCON/DuRSAAM urban concrete family presented in this book.

## 1.2 URBCON/DuRSAAM concrete technology

The design, durability and performance of structures play a crucial role in fostering societal and economic growth. Concrete structures are used extensively for buildings, transport, infrastructure, and maritime applications. By using concrete extraordinary structures can be realised, and these are often designed for long service lives to gain optimal value from the material, environmental, intellectual, and financial input into the making of the structure. In Europe, around 4 tonnes of concrete per capita [1] are consumed annually. The downside of using concrete is associated with durability issues and huge environmental costs, as the cement industry accounts for 8% [2] of global anthropogenic carbon dioxide emissions; and around 60% of all non-renewable resources are used in construction, making it one of the least sustainable industries [3][4]. There is a clear demand for a new, sustainable generation of construction materials, since Portland cement (PC)-based concrete alone cannot meet all the challenges of modern society concerning durability and sustainability.

Replacement of the cement with supplementary cementitious materials (SCMs) to create blended cements is the most utilized way to reduce costs, improve carbon footprint, and avoid landfilling. And their usage increased significantly over the last three decades. Furthermore, SCMs are mostly by-products of different industrial processes, such as coal combustion and metal production which are fly ash (FA) and metallurgical slags. The extent of cement replacement depends on reactivity of the SCM and its chemical composition. By making use of alkali-activation, clinker can completely be omitted from concrete, maximizing performance of raw materials as shown in [Figure 1-1](#).

## Traditional concrete



## Alkali-activated concrete

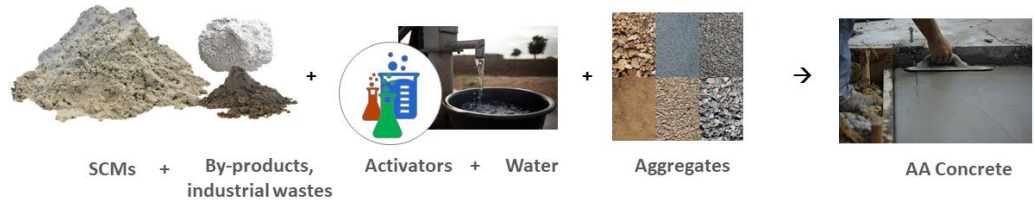

*Figure 1-1 Portland cement-based concrete vs. AAM concrete*

Alkali-activated material (AAM) is a broad classification, encompassing essentially any binder system derived by the reaction of an alkali metal source (solid or dissolved) with a reactive solid, an amorphous silicate powder [5]. Due to the potential to design a dense AAM concrete, durability is predicted to be excellent. Alkali metal sources can be called activator and amorphous powder is referred to as a precursor. Activators are various alkaline salts, typically hydroxides, silicates, carbonates, and sulphates, while precursors are FA, kaolin and metakaolin clays, blast furnace slag (BFS) and other silica rich slags, municipal solid and even glass waste. In literature, AAM concrete is also termed geopolymer concrete. According to their definition [6], geopolymers are in fact, subset of AAMs synthesised via alkali-activation of alumina rich silicate precursors such as fly ash and metakaolin.

The concept of alkaline activation has been known to the academic community since early 1900s, and objects in service in Belgium, former USSR, China, and Australia prove their durability [5]. Most of these endeavours were driven by local shortages of clinker and their development would typically diminish after the shortage. Fundamental research in the 1990s which concentrated mostly on the microstructure [5], created solid foundations for recent research on durability [5][7][8], service life prediction and engineering properties [9]-[11]. Even though the interest in AAMs boomed over the last two decades, further research, the erection of flagship projects and transition towards performance-based design of cement and concrete products and structures are needed to create a framework of possibilities, demonstrate effectiveness, and increase overall confidence in AAMs. A lot has been achieved in this respect over the past years, including the work performed by the URBCON and DuRSAAM projects, and is bundled in this book.

Concrete construction industry is increasingly driven by the growing demand for durable yet cost-effective solutions and the greater focus on reliable and comprehensive eco-efficient material technologies, to supplement or partially replace traditional construction materials in key market segments. Global cement consumption amounts to 4200 Mt per year and represents a value of around 225 B€. The addressable market for AAM binder is estimated to amount to 20% of the conventional cement market. This corresponds to 5B€/y for Europe (Figure 1-2 demonstrates how this number is derived) in materials alone, and much more in the related construction activities with AAM concrete. The growing attention dedicated to AAM concrete can also be perceived from e.g. the published UK Specification PAS 8820:2016 on AAM Cements and Concretes.

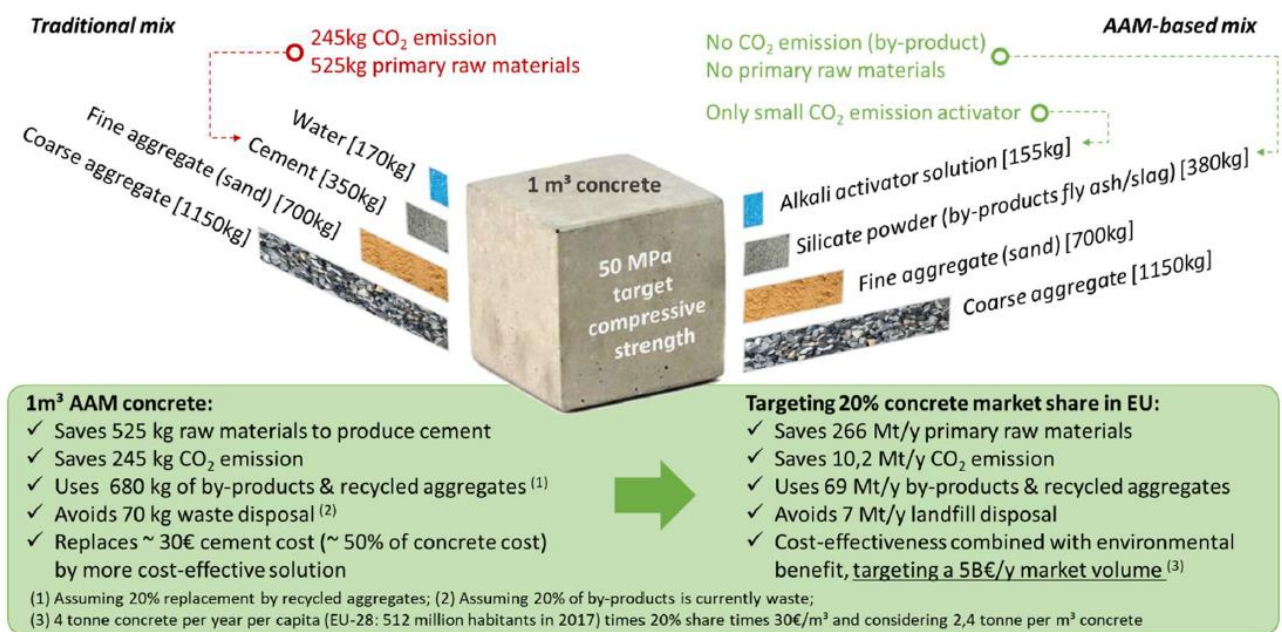

Figure 1-2 Originality of AAM concrete as a driver for more sustainable construction

The URBCON/DuRSAAM concrete technology platform, based on alkali-activated materials, has the ambition to maximize impact of this eco-friendly concrete family, not only by targeting to be free of traditional Portland clinker, but also by targeting to be free of primary resourced construction minerals. This to minimize the use of natural resources of Earth, to lower CO<sub>2</sub> impact and to help avoiding the associated climate changes, while keeping excellent technical performance of concrete as a construction material. Basically, the URBCON/DuRSAAM concrete technology platform achieves this by making use of alkali-activated materials at the one hand and making extensive use of mineral by-product streams from make & energy industries at the other, as well as of construction and demolition waste from the construction industry.

### 1.3 AAM concrete in brief

A brief description of AAM concrete, sometimes also referred to as geopolymers concrete, is given in this section. For more comprehensive and extended information, reference is made to the other chapters of this book.

The composition of traditional concrete and AAM concrete is analogous, as indicated in Figure 1-1. The cement is replaced in AAM concrete by mineral powders (fineness comparable to cement) that will harden by activating these mineral powders with an aqueous solution of alkalis, in contrast to cement that only needs water to harden. Therefore, both concrete types use an alternative chemical route to hydrate into an overall similar artificial rock, based on C(A)SH-like compounds (calcium (alumino)silicate hydrates).

The binder components of AAM concrete are mineral powders (called 'precursors'), which are activated by means of alkalis (called 'activators'). The mineral powders are industrial by-products such as metallurgical slags, combustion ashes and calcined clays, of which some have already a tradition to be used as secondary cementitious materials (SCMs) in blended cements. The dosage of these mineral powders, which act as binders instead of cement, is slightly higher than for traditional concrete. As an order of magnitude, the dosage is around 400 kg per m<sup>3</sup> of concrete, however, this



depends on the specific mix. Various chemical components can be used for the alkalis, but often a combination of sodium silicate (water glass) and sodium hydroxide is used. The dosage in terms of dry mass of alkalis is, for example, an order of magnitude of 5 mass% with respect to the binder content, for an AAM concrete based on blast furnace slag. The further mix proportioning in terms of fine (sand) and coarse aggregates is the same as with traditional concrete and is performed based on optimal packing distribution. In this respect, it is also possible to use recycled or artificial aggregates in AAM concrete. The application of a hybrid solution of concrete with a low dosage of cement and a high dosage of by-products additionally activated, further belongs to the options.

AAM concrete is compatible with current solutions for reinforcing concrete (reinforcing steel, fibre reinforced concrete, ...) and pilot projects with AAM concrete have already been realized in various countries. The characterization and application of AAM concrete is however less advanced than traditional concrete, and the regulatory framework is still limited. Like for traditional reinforced or prestressed concrete, AAM concrete mixes are designed to have good workability, mechanical performance, and durability:

The workability of AAM concrete is generally somewhat more viscous and hardens faster, whereby attention is given in the mix design to obtain a sufficient workable time for the fresh concrete.

High compressive strengths are generally easy to achieve but requires attention in the mix design and curing to keep shrinkage deformations under control.

Due to its generally denser microstructure, AAM concretes can achieve strong durability properties. On the other hand, the chemical structure of AAM concrete and traditional concrete is not identical, so that further durability tests are recommended to characterize the durability of AAM concrete mixes. In general terms, the durability of AAM concrete is comparable to that of a cement-based concrete, although there might be differences (e.g., carbonation resistance of AAM concrete may be slightly less, resistance to chloride penetration slightly better).

A common concern of engineers considering AAM concretes for the first time is damage by ASR (alkali-silica reaction). This durability aspect has been examined by various researchers and has not been reported as a problem so far. This is attributed to the fact that alkalis are not freely available in the hardened concrete but participate in the chemical processes that allow AAM concrete to harden.

In addition to workability, strength, and durability, AAM concretes have a far more positive environmental impact. At the one hand this is since Portland clinker-based cement, with its relatively high environmental impact, is avoided and on the other because less primary raw materials are used. The exact gain in environmental impact is not always straightforward to establish, because this depends on (1) the details of the AAM concrete composition, (2) the type of traditional concrete used as a reference for comparison (e.g. concrete based on Portland cement CEM I or CEM III), and (3) to which extent the environmental impacts of the by-products are allocated to its originating production or to the AAM concrete. Under the assumption that mainly the environmental impact of the grinding of the mineral powders is assigned to the AAM concrete and in reference to concrete types with high Portland clinker amounts, values are mentioned of an environmental gain of 50% and more, in terms of carbon footprint. Furthermore, in terms of end-of-service-life, AAM concrete is recyclable and reusable according to common practices. This has been reported, though studies in this respect are still limited.

By-products for AAM concrete are selected or blended with care, to come to proper mix proportions and to exploit the reactivity of the by-products. It might also be of interest to apply beneficiation treatments on the by-products, to purify them from e.g., valuable metals and to make sure that there is no potential leaching of harmful elements. Environmental permits to use some types of by-products as constituent for concrete might be applicable, depending on national legislation.

Much more information on AAM binders and concretes, in a wider context of concrete technology, is provided in the following chapters. For further reading on AAMs, also reference is made to the RILEM Handbook “Alkali Activated Materials: State of the Art Report, RILEM TC 224 AAM”, ISBN 978-94-007-7671-5. A link to this handbook is provided [here](#).

#### 1.4 How this concrete technology fits circular & sustainable construction?

Circular & sustainable construction is a broad term, which encompasses different dimensions to minimize the environmental impact of the built environment. This can be accomplished in many ways, such as for example:

- Designing for the future, allowing for circular material loops (multi-functional & adaptable, layered construction approach, demountability, recyclability, etc.)
- Designing for reduced usage of resources by avoiding use of primary natural resources or by more slender (less material intensive) solutions
- Sustainable solutions targeting a long service life and service life extension
- Sustainable solutions for energy efficiency and energy renovation
- Construction materials & products with low environmental impact
- Construction materials & products allowing refurbishment or remanufacturing to give them a next life
- Application of secondary material resources through urban mining, by-products, construction & demolition waste, ...
- Re-use and re-cycling
- Material passports, data & BIM to map and disclose the circularity potential over time
- Life cycle analysis to quantify the overall environmental gain
- Circular business models and partnerships, governance and tendering formats facilitating circular construction, construction products certification programs adapted to 'green' solutions.

These approaches facilitate a circular concept (Figure 1-3), as opposed to a more linear waste driven end-of-life concept. Moreover, these different approaches are applicable to different layers typically involved in buildings and infrastructure, as also indicated in Figure 1-3.

The URBCON/DuRSAAM concrete technology acts on this mainly with respect to the load bearing structure of buildings and infrastructure, which is predominantly made in concrete. Concrete might also be part of the skin of many structures. The URBCON/DuRSAAM concrete family excels in avoiding use of primary natural resources, has good technical performance allowing for long service lives and slender designs, applies urban mining concepts (by-products and construction and demolition waste), realizes lower environmental impact (especially reduction in CO<sub>2</sub>) and stimulates circular economy partnerships between construction companies and by-product providers.

Note that in terms of reduced environmental impact of concrete, different solutions are made available. This includes more efficient clinker production, use of recycled or artificial aggregates, use of blended cements via secondary cementitious materials and the use of alternative binders. The URBCON/DuRSAAM concrete technology platform combines the use of alternative binder technologies, namely alkali-activated materials, with the further use of by-products and construction & demolition waste in avoiding primary raw materials (both for the binders as well as for the aggregates). As such it can be stated that different eco-concrete solutions will become more and more available on the construction market, among which the URBCON/DuRSAAM concrete family.

*Continuous material cycles / flexible productive structures / long service life & maintenance / design for different use scenarios and deconstruction / reuse – refurbish – redistribute / recycle*

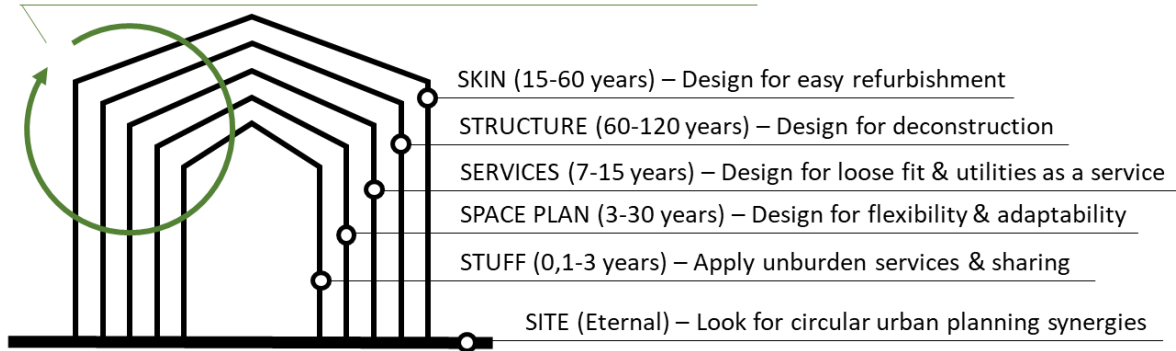

*Figure 1-3 Circularity in the construction sector (based on Brand shearing layers model and circularity concepts by Ellen Macarthur Foundation)*

## 2 AVOIDING PRIMARY RAW MATERIALS AND REDUCING THE CARBON FOOTPRINT

### 2.1 Introduction

Concrete is the most important construction material and the second most used material on our planet only next to water [12]. Compared to other building materials such as steel and timber, concrete exhibited more sustainable features in terms of CO<sub>2</sub> emission and energy consumption per volume production [13][14]. On the other hand, it has been reported that the production rate of concrete is approaching 25 giga tons (Gt) per year [15], and such advantages have been eliminated due to the high-volume consumption [16]. The production of concrete may contribute to about 8% of the worldwide CO<sub>2</sub> emission, accompanied by severe consumption in energy and natural resources [17][18].

With the increased awareness of global climate change induced by CO<sub>2</sub> emission in recent years, different strategies have been proposed to reduce the resource consumption and CO<sub>2</sub> emission from the concrete industry [19]. For instance, improvement of rotary kiln systems [20][21][22] and increased use of biofuels [19] have been proposed to improve energy efficiency during Portland clinker production. In the meantime, as shown in Figure 2-1, recycled materials including wastes and industrial by-products have been increasingly used in concrete production as well to further mitigate the environmental impact. As the least environmental-friendly fraction, great efforts have been made by replacing cement with alternative binding materials to produce “green concrete” [16][23][24].

More eco-friendly concrete may have the ambition to both avoid the use of primary raw materials, as well as to reduce the carbon footprint. This can be achieved at 2 levels, corresponding to the main components of concrete, namely its binder and the aggregates. This involves the use of alternative materials, referred to in Figure 2-1 as SCM (supplementary cementitious materials) and aggregate replacement.

In the following a discussion is provided on these concrete components as they have been traditionally used in previous decades, and how this is gradually shifting into the use of adapted concrete components as construction minerals, that avoid primary raw materials and further reduce the carbon footprint. In this respect, the URBCON concrete family of mix formulations targets to have an adapted binder system, that makes use of by-products that are alkali-activated, and that (partially) uses aggregates based on construction and demolition waste or by-products, rather than natural aggregates.



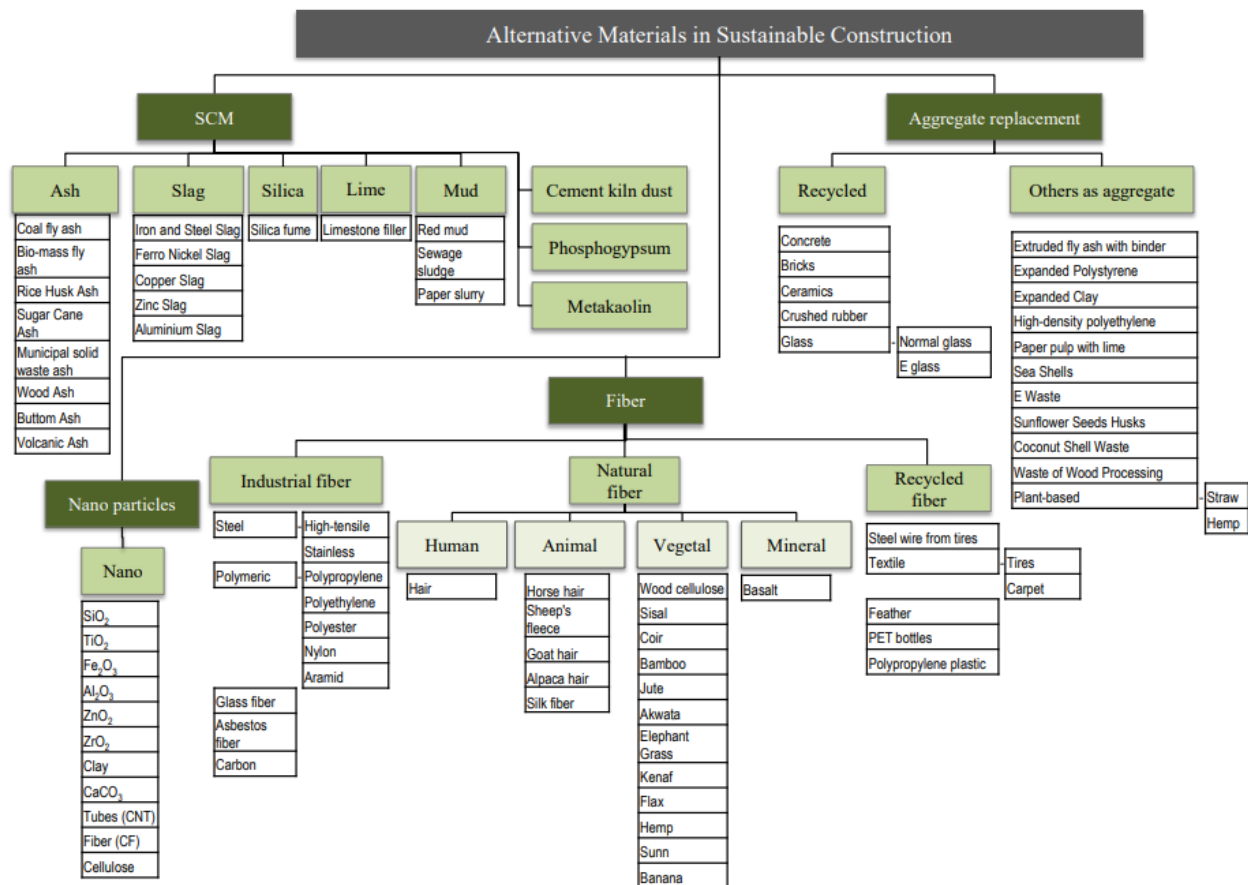

Figure 2-1 Comprehensive overview of possible alternative materials in concrete (adapted from [25])

## 2.2 The binder part in concrete

One of the most important parts in the composition of concrete is the binder. It is responsible for the hardening of the fresh concrete into an artificial stone, the latter having cost-effective properties for use as a building material. Portland cement has been used as the major binding material in concrete ever since it was developed about two centuries ago, making use of Portland clinker. The Portland clinker production typically uses 1.5 kg of primary raw materials and involves 0.7-0.8 kg CO<sub>2</sub> emission per kg clinker. Contrary to cement almost fully based on Portland clinker (so-called CEM I in Europe), a wide range of Portland cement types with lower clinker content have been developed making use of so-called supplementary cementitious materials (SCMs) that are industrial by-products of mineral nature. In the following sub-sections a further discussion is provided on these Portland cements (Section 2.2.1) and SCMs (Section 2.2.2).

Taking this a step further, this different kind of industrial by-products can also be used to make a concrete type completely free of Portland clinker. This, in the case of the URBCON and DuRSAAM projects, is done by combining the industrial by-products (in that case no longer called SCMs, but precursors) to an alkaline medium (in that case no longer obtained via reaction of Portland clinker, but by chemicals called alkali-activators). This binder system of alkali-activated precursors is discussed further in Section 2.2.3 and Chapter 3.

In the following use is made of typical abbreviations associated with binder chemistry, such as H = water (H<sub>2</sub>O), C = calcium oxide or lime (CaO), S = silicon dioxide or silica (SiO<sub>2</sub>), A = aluminium oxide

or alumina ( $\text{Al}_2\text{O}_3$ ), N = sodium oxide ( $\text{Na}_2\text{O}$ ). This allows to abbreviate typical main binder reaction products, such as CH = calcium hydroxide (portlandite), C-S-H = calcium silicate hydrate, or more complex hydrates including C-A-S-H and N-A-S-H.

### 2.2.1 Clinker based cement

The use of Portland clinker-based cement is most wide-spread in concrete practice. How Portland clinker is produced, and the various cement types made with Portland clinker are discussed in the following. Note however that some alternative clinkers have been developed as well, of which 2 of them are also discussed hereafter. Compared to Portland clinker-based cement, these alternative clinkers have a more limited application.

In the URBCON concrete family, clinker-based cement as a binder is typically replaced by alkali-activated binder. Nevertheless, so-called hybrid mixes have also been successfully demonstrated in URBCON, that combine alkali-activated binders with a low dosage of clinker-based cement.

#### 2.2.1.1 Portland clinker-based cement

Cement is a construction material that sets automatically because of chemical reactions with water and subsequently retains its strength and soundness both when exposed to air and submerged in water. Portland cement has been used as the major binding material in concrete ever since it was developed about two centuries ago. As illustrated in [Figure 2-2](#), the production of cement can be divided into two basic steps: the calcination of clinker (at about  $1450^\circ\text{C}$ ) and afterwards the grinding of clinker with other materials (e.g. gypsum) [15]. As such cement consists of finely ground Portland cement clinker and calcium sulphate (natural gypsum, anhydrite, or gypsum from flue gas desulphurisation). In addition, cement may contain other main constituents (see also [Section 2.2.2](#)), such as granulated blast furnace slag, natural pozzolana (e.g., trass), fly ash, burnt oil shale or limestone.

However, the high-temperature process involving clinker production is intensively energy-consuming [26], and the combustion of fossil fuels contributed to 40%-50% of the total  $\text{CO}_2$  emission from cement production [27][28]. Besides these, the most concerning emissions are related to the chemical reaction of decomposition of limestone during calcination, which are intrinsic emissions to Portland cement production [29][30]. In 2012, the global production of cement reached 3.8 Gt (approximately released 3.2 Gt of  $\text{CO}_2$  into the atmosphere), which further increased over 4.5 Gt in 2015 [19]. Regarding concrete production, cement is the critical source resulting in environmental impact, which accounted for approximately 96% of the carbon footprint and 85% of the embodied energy of concrete [31].

What is known as Portland cement clinker is made from a raw material mix mainly consisting of calcium oxide ( $\text{CaO}$ ), silicon dioxide ( $\text{SiO}_2$ ), aluminium oxide (alumina ( $\text{Al}_2\text{O}_3$ )), and iron oxide ( $\text{Fe}_2\text{O}_3$ ). These chemical constituents are supplied by limestone, chalk and clay or their natural blend, lime marl, limestone and chalk are composed of calcium carbonate ( $\text{CaCO}_3$ ). The major constituents of clay, which is a natural product of weathering processes, are fine-grained minerals and smaller quantities of quartz and feldspar, which constitute residues of the starting material. Clay minerals and feldspar are compounds of aluminium oxide and silicon dioxide (aluminosilicates) with alkalis, such as sodium and potassium. The iron oxide required for melt formation is either contained in the clay minerals in the form of ferrous hydroxide or it is added in the form of iron ore. For the cement to conform to the quality requirements stipulated, a precisely defined raw material composition must be complied with. Only a small margin of deviation can be tolerated.

The raw material mix is heated up to a temperature of approximately  $1.450^\circ\text{C}$  in a rotary kiln until it starts sintering. This results in the starting materials forming new compounds known as clinker phases. These are certain calcium silicates and calcium aluminates which confer on the cement its

characteristic feature of setting in the presence of water. The clinker burnt in the rotary kiln is subsequently ground to cement in finish mills with calcium sulphate and, if necessary, with further main constituents being added. The calcium sulphate serves to adjust the setting behaviour of the cement to obtain optimum workability of the product during concrete production.

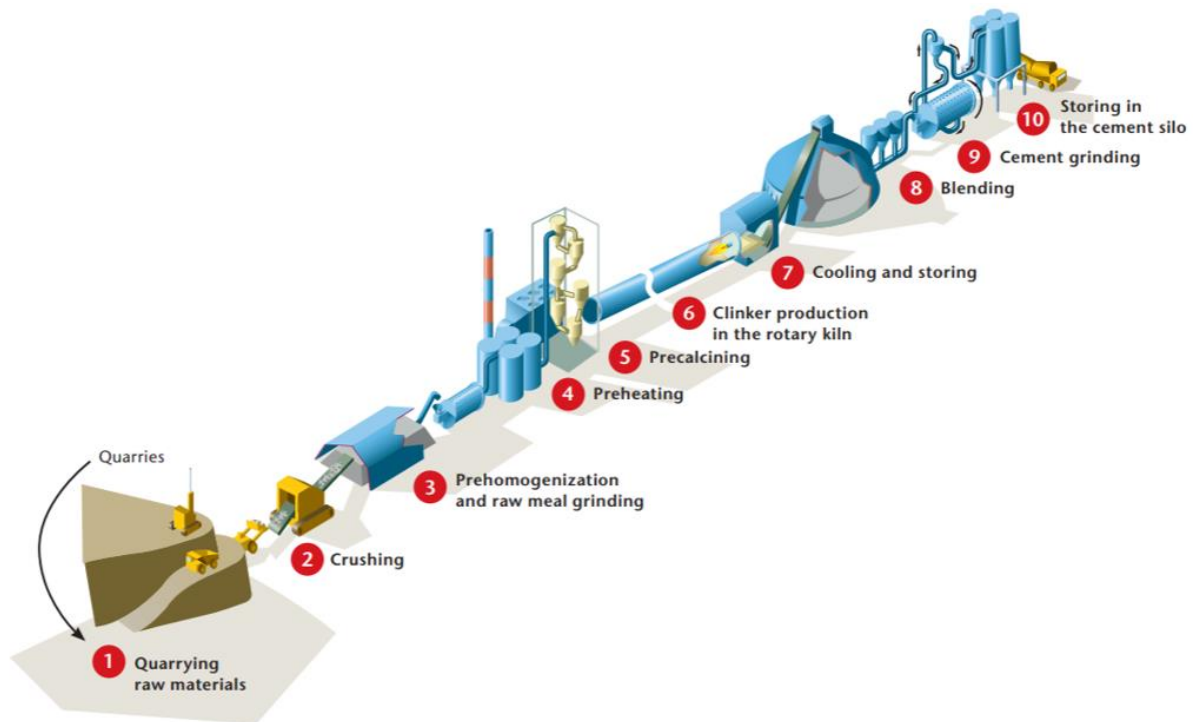

*Figure 2-2 Schematic representation of the cement manufacturing process from quarry to dispatch [15]*

In its basic form Portland cement is composed of at least 95% clinker, with the additional calcium sulphate to control the setting behaviour of the cement. In reference to European cement standards EN 197-1 and EN 197-5, this cement type is indicated as CEM I. By making use of supplementary cementitious materials (SCMs), that are substances of silicate, aluminate or calcareous nature, different forms of pre-blended cement types can be produced as well. These SCMs are for example ground granulated blast furnace slag (discussed in [Section 2.4.1.1](#)), fly ash (discussed in [Section 2.4.1.2](#)), unburnt limestone or (natural) pozzolana. The combination of these main constituents with Portland cement clinker leads to different cement types defined in European cement standards EN 197-1 and EN 197-5. These types are:

- CEM I. Portland cement (>95% clinker) acc. to EN 197-1
- CEM II. Portland-composite cement (65-94% clinker) acc. to EN 197-1
- CEM II/C-M. Portland-composite cement (50-64% clinker) acc. to EN 197-5
- CEM III. Blast furnace cement (5-64% clinker) acc. to EN 197-1
- CEM IV. Pozzolanic cement (45-89% clinker) acc. to EN 197-1
- CEM V. Composite cement (20-64% clinker) acc. to EN 197-1
- CEM VI. Composite cement (35-49% clinker) acc. to EN 197-5

As an example [Figure 2-3](#) shows the relative utilisation of different cement types in Europe, during the period 2000 till 2019. As the standard EN 197-5 was published in 2021. CEM II/C-M and CEM VI cements do not appear in the bar chart.

Combing these cements with water results in the hydration of cement, resulting in solid binder products responsible for the curing of concrete. For more information on hydration of cement, reference is made to specialized literature, but basically CH and C-S-H are formed as main binder reaction products.

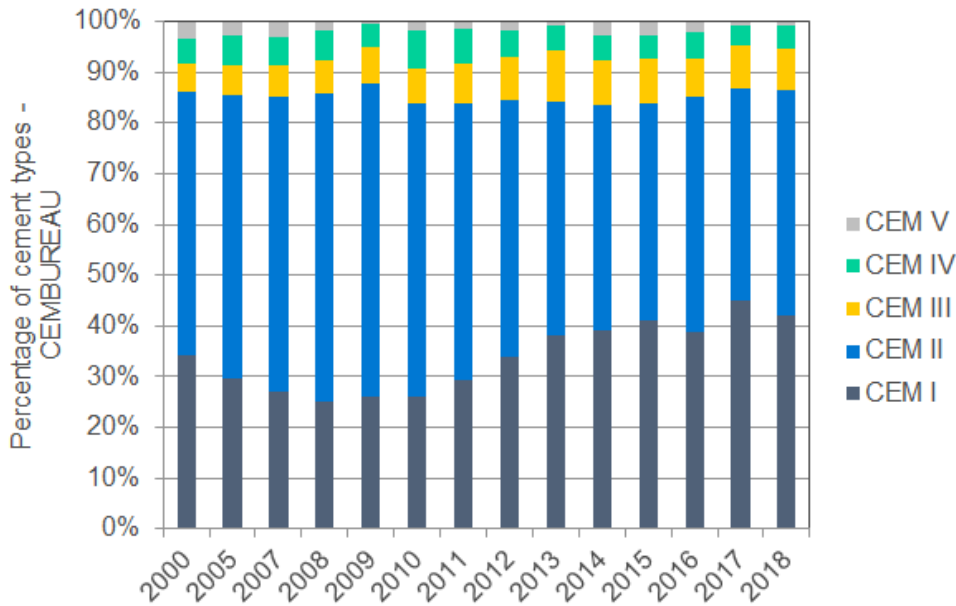

Figure 2-3 Domestic European cement delivery [32]

### 2.2.1.2 Calcium sulfoaluminate cement

Like Portland cement clinker, calcium sulfoaluminate cement clinker (CSA clinker) is burnt in rotary kilns [33]. The burning temperature is around 1350°C and is thus around 100°C lower than in the burning process of PC clinker. CSA clinkers fired at lower temperatures (approx. 1200°C) can have a higher early strength, but also lower final strengths and significantly reduced workability times.

Limestone, bauxite, and gypsum are generally used as raw materials. The resulting mineral phases after burning process are essentially Yeelimite, Belite, Ferite, Anhydrite and Aluminate [34][35]. Like Portland cements, CSA clinkers are ground after firing with calcium sulphate (usually gypsum or anhydrite). However, larger quantities are used to ensure that mainly Aft phases are formed during hydration. The reaction mainly responsible for strength formation is the formation of ettringite from Yeelimite, calcium sulphate and water. Besides, Belite reacts later in the hydration process to form C-S-H - phases and thus contributes to hardening [36].

Next to the somewhat lower burning temperature, the environmental gain of CSA clinker is also associated to the chemical reactions in the kiln, as compared to Portland clinker. For the strength-forming phases alite and belite of the burnt Portland cement clinker, the raw material-related CO<sub>2</sub> emissions are 0.58 kg/mol and 0.51 kg/mol, respectively. The raw material-related CO<sub>2</sub> emission for Yeelimit is approx. 0.22 kg/mol.

CSA cements can be used like Portland clinker-based cements, often with the use of a retarder (e.g. based on citric acid) to compensate for the lower workability times of CSA. In addition to ecological advantages, the technical advantages of CSA cements are discussed in various literature sources. Compared to Portland cements, concretes with such cements show a significantly faster strength development, a high sulphate resistance and a high frost resistance [36][37]. Other durability properties of concretes with CSA cements are controversially discussed in the literature. Results of laboratory tests show [38] that Ettringite is not very stable against chlorides and CO<sub>2</sub> and thus the

chloride migration and carbonation resistances only fulfil the normative requirements to a limited extent. This may be a problem for reinforced and pre-stressed concrete components (chloride migration and carbonation lowers the pH value, depassivating the steel reinforcement and making it prone to corrosion). This contrasts with results from [39], according to which building samples from concretes with CSA cements show a high resistance to carbonation. Investigations on chloride penetration resistance in [40] show that the chloride migration coefficient and the scaling in freeze-thaw tests with de-icing salts of concretes with CSA cement is significantly higher compared to concretes with Portland cement clinker-based cement. Lowering the water/cement ratio, a common concrete technology measure for Portland cement clinker-based cements, is only partially effective in this case, as the amount of water necessary for the formation of Ettringite may no longer be available. Accordingly, fewer hydrate phases would be formed. The microstructure would not become denser but coarser.

Compared to Portland clinker-based cements with CE mark according to European standards to demonstrate consistent technical quality, some technical approvals are also available for CSA cement (e.g. in Germany (Z-3.15-2130) and on the European level (ETA-19/0458, ETA-13/0417, ETA-13/0418, ETA-13/0419)). However, these approvals are limited in their applicability: concretes with the CSA cement from German technical approval are not to be used in all exposure classes. XD, XS (resistance to chloride penetration) as well as XF2 and XF4 (freeze-thaw resistance) are excluded. Also, the mentioned ETAs are not always declaring performance for carbonation resistance, resistance against chloride penetration and freeze-thaw resistance with de-icing salts in any case. Only one ETA (ETA-13/0419) is giving this information for all the mentioned durability properties.

### 2.2.1.3 Calcium aluminate cement

Calcium aluminate cements (CACs) are an important category of non-Portland clinker-based cements. Nevertheless, use of this type of cement is almost three times lower than Portland clinker-based cement. Main chemical compositions of CACs are calcium aluminate phases as shown in Figure 2-4 containing lower amount of silica in comparison with Portland cement [41]. The major raw materials for calcium aluminate cements production are Bauxite in addition to limestone.

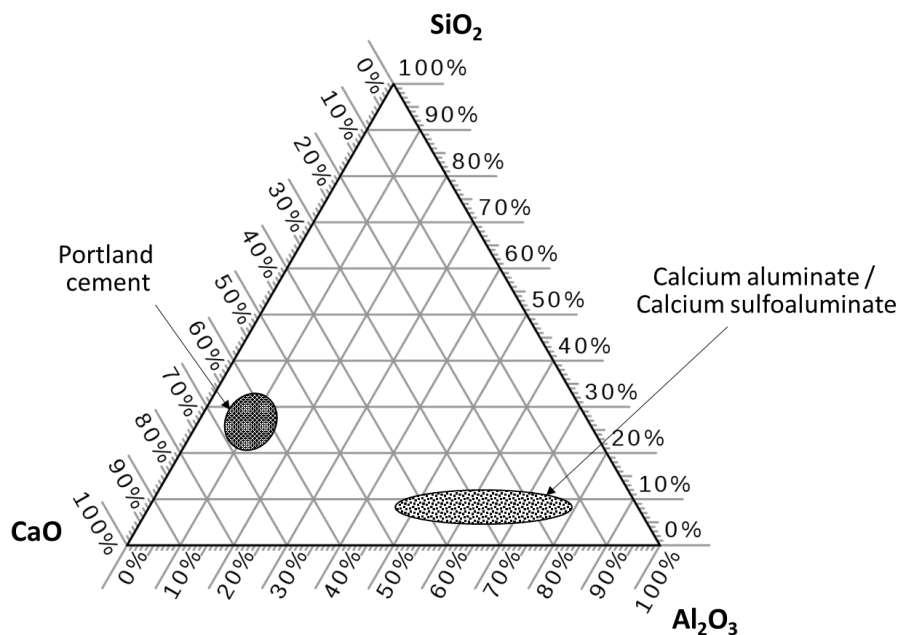

Figure 2-4 Zones of cementitious materials in the CaO-SiO<sub>2</sub>-Al<sub>2</sub>O<sub>3</sub> (adapted from [41])

CACs are widely used in castable refractories and dry mix mortars for special applications which consume 80% of its total production, whereas assigning less than 20% of usage purposes for technical applications, such as sewer lining, rapid repair and so forth [41]. Contemporary CACs made with ferruginous Bauxites include 38%-40%  $\text{Al}_2\text{O}_3$  (next to about 40% CaO and some iron oxide) are standard grade suited for concrete and formulated mortars; while CACs with higher  $\text{Al}_2\text{O}_3$  content (beyond 50%  $\text{Al}_2\text{O}_3$ , next to less than 40% CaO and no iron oxide) are generally used for refractory applications. The silica content must be usually lower than 6%. Blended CACs with other types of binders can improve the setting-times, shrinkage, and early age compressive strength.

The manufacturing process of CACs is different from that of Portland cement and is highly related to the alumina content of the raw materials. Manufacturing the standard grade of CACs is generally carried out by a water-cooled vertical furnace, lined with refractory material superseded by reverberatory open-hearth furnace (Figure 2-5). It is fired with pulverised coal or oil blasting hot air through. The furnace gases blowing through the raw materials are evaporating water, decomposing the limestone into CaO and release carbon dioxide. Electric arc furnaces also can be used in some cases but the output of these furnaces is considerably lower. The final product resembles a dark, fine-grained compact rock like basalt that is crushed and ground in a ball mill.

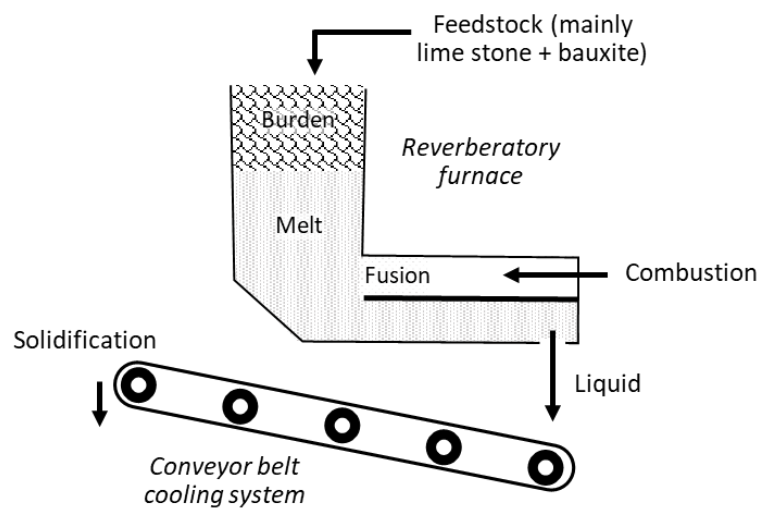

Figure 2-5 Reverberatory furnace (adapted from [41])

### 2.2.2 Supplementary cementitious materials

Supplementary cementitious materials (SCMs) are widely used in concrete as partial replacement of clinker to produce cement or added in a concrete mixer to replace Portland cement [42][43]. SCMs are mainly wastes and by-products generated by other industries. A partial replacement of clinker with these materials considerably reduces the  $\text{CO}_2$  emissions of the final product, as clinker has the greatest impact on  $\text{CO}_2$  emissions [42]. Among all alternatives, blast furnace slag and coal fly ash are the most representative SCMs, which are industrial by-products from pig iron production and coal combustion in power plants, respectively. A small portion of SCMs (5-20%) blended in concrete brings benefits on both economics and long-term properties of concretes, while on the other hand, high volume replacements result in a reduction in early-stage properties of concretes [44]. An overview of SCMs is presented in Table 2-1, which shows the variety and availability of SCM resources. Apart from that, agricultural wastes with pozzolanic properties such as rice husk ash, palm oil fuel ash, bagasse ash, wood waste ash etc. have been used as SCMs as well in more recent years [45].



Table 2-1 Overview of materials used or considered as SCMs [46]

Material	Chemistry	Volume est. (Mt/y)	In Use	Comments
Blast furnace slag	Ca-Si-Al	300-360	Y	Nearly fully used, latent hydraulic
Coal fly ash-Si rich	Si-Al	600-900	Y	Subject to limitations on carbon content, reactivity
Coal fly- Ca rich	Si-Ca-Al	100-200	Y	Subject to limitations on C, Cao , MgO content; latent hydraulic
Natural pozzolans	Si-Al	75	Y	Large variety/variability, often high water demand
Silica fume	Si	1-2.5	Y	Used in high-performance concrete
Calcined clays	Si-Al	2-3	Y	Metakaolin performance best, often high water demand
Limestone	CaCO <sub>3</sub>	300	Y	Cementitious contribution in combination with reactive aluminates
Biomass ash	Si	100-140	N	Competition with use as soil amendment, high water demand
MSWI bottom ash	Si-Al-Ca	30-60	N	Expansive and corrosive components, leaching issues
Steel slag	Ca-Si-Fe	170-250	N	Various tapes, can contain expansive components (Cao) or leachable heavy metals (Cr,..), low reactivity
Copper slag	Fe-Si	30-40	N	Low reactivity, leaching of heavy metals, more research needed
Other non-ferro slag	Fe-(Si)-(Ca)	5-15 each	N	Low reactivity, leaching of heavy metals, more research needed
Bauxite residue	Fe-Al-Si	100-150	N	High alkali content, low reactivity, colour
Waste glass	Si-Na-Ca	50-100	N	Glass recycling preferable, high alkali content

SCMs normally contain lower calcium content than Portland cement, as indicated in Figure 2-6, which further modifies the primary hydration product C-S-H [44][47][48]. The composition, fineness, and reactivity of SCMs play an important role in affecting the fresh and hardened properties of cementitious materials [42].

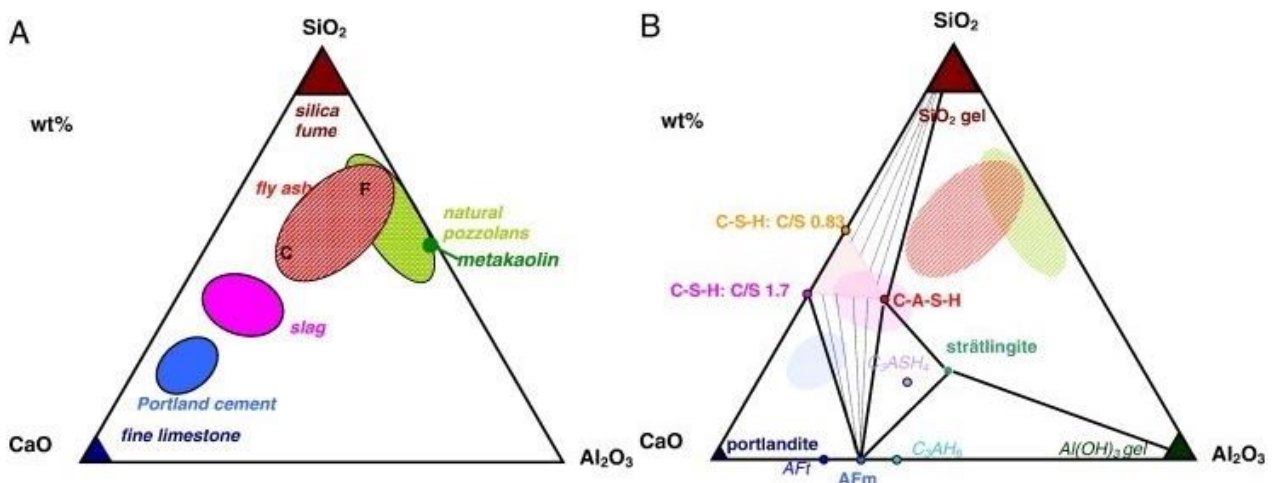

Figure 2-6 (A) CaO-Al<sub>2</sub>O<sub>3</sub>-SiO<sub>2</sub> ternary diagram of cementitious materials; (B) hydrate phases in the CaO-Al<sub>2</sub>O<sub>3</sub>-SiO<sub>2</sub> system (adapted from [42])

The availability of SCMs is not in the range of massive cement production. Therefore, the use of a wider range of SCMs has become of interest. Given the highly diverse SCM properties, it is crucial to standardize their application in concrete mixtures to ensure the material properties. Due to the increasing pressure on environmental issues, more restrictions have been raised on the upstream industries to achieve sustainable production. For instance, according to the coal phase-out policy [49], the coal power plants have been shutting down in many countries to meet the emission targets, which significantly reduces the supply of coal fly ash as a major SCM. Therefore, new alternatives in SCMs with a cleaner production process are required to fulfil the demand in concrete production.



### 2.2.3 Alkali-activated binders

Alkali-activated binders are zero-cement low-carbon binders, generated from the reaction between calcium- and alumino-silicate based mineral powders, commonly called precursors, and an alkaline activator solution, commonly mixtures of sodium hydroxide and sodium silicate. These alkali-activated materials (AAMs) form a binder which can replace Portland cement-based materials in overall properties. The function of the activator is to introduce the driving force needed for the dissolution of the calcium, silica, and alumina present within the precursor materials and to promote their subsequent polycondensation through the alkaline liquid media. The main chemical and physical differences between calcium silicate cementitious systems (Portland cement-based materials) and alkali-activated materials are summarised in Table 2-2. Note that in this table AAMs are further divided in high- and low-calcium AAMs. Whereas ‘alkali-activated materials’ and ‘geopolymer’ are terms that are often used interchangeably, more strictly speaking geopolymer can be regarded as a subset of alkali-activated materials, with low-calcium characteristics and an associated polymerization type of reaction.

A more elaborate discussion on alkali-activated binders is given in Chapter 3.

The impact in reduction of CO<sub>2</sub> emissions that AAMs have, reaches 20-50% if compared to traditional Portland cement-based materials [50]. However, the aluminosilicate sources (precursors) used for AAMs production are usually the same classes of materials used as SCMs, making this technology competitive with the traditional cement industry.

*Table 2-2 Comparison of reaction mechanisms and definition of different binder systems (adapted from [51])*

Binder	Cementitious binders	High-calcium alkali-activated binders CaO > 10wt%	Low-calcium alkali-activated binders - Geopolymer CaO < 10wt%
Reaction	Hydration	Hydration, polymerization	Polymerization
Raw materials: powder precursors	Portland cement and supplementary cementitious materials	Aluminosilicate activated raw materials (high Ca content)	Aluminosilicate activated raw materials (low Ca content)
Raw materials: reactants	C <sub>2</sub> S, C <sub>3</sub> S, C <sub>3</sub> A, C <sub>4</sub> AF (mainly crystalline) Water	Reactive aluminum-, calcium (hydraulic) and silicon-containing compounds (mainly amorphous); Alkali-source; Water	Reactive aluminum- and silicon-containing compounds (mainly amorphous); Alkali-source; Water
Strength-forming reaction products	Amorphous multi-phase system	Amorphous multi-phase system	Polycondensates (macromolecules)
Primary reaction phases	Ca-rich C-S-H and C-A-H phases, high C/S ratio (C/S=1.0-2.0).	Ca poorer C-S-H and, low C/S ratio (0.9-1.2), incorporation of Al (C-A-S-H)	Aluminosilicate (N-A-S-H)
Secondary reaction phases	CH, AFm, Aft	Hydrotalcite, C <sub>4</sub> AH <sub>13</sub> , CASH <sub>8</sub> , C <sub>4</sub> A <sub>2</sub> H <sub>11</sub> , C <sub>8</sub> A <sub>2</sub> H <sub>24</sub> Aluminosilicate (N-A-S-H and/or C-A-S-H)	Zeolites, hydroxysodalite, Zeolite P, Na-chabazite, Zeolite Y, Faujasite

Definition of the binder	Cement is a hydraulic binder, that is, finely ground inorganic material which, when mixed with water, forms a paste which sets and hardens by means of hydration reactions and processes and which, after hardening retains its strength and stability even under water (EN 197-1:2011-11)	Alkali-activated binders can be defined as mineral, inorganic, non-metallic binders whose setting and hardening is based on the external addition of an alkaline-mostly liquid-activator to a source material rich in silicon and aluminum.	A Geopolymer is understood as a family of mineral binders who's amorphous to semi-crystalline, three dimensional aluminosilicate network is closely related to artificial zeolites.
--------------------------	--	---	---

## 2.3 The aggregates part in concrete

### 2.3.1 What are aggregates and going beyond natural aggregates

Aggregates are coarse, particulate materials derived primarily from natural sources such as rocks and sand. Rock-sourced materials will require crushing and grading whilst some naturally eroded materials, such as sea dredged sands and gravels, may simply require cleaning and grading. Two types of aggregates may be defined further as primary, i.e., those produced from quarried or dredged natural sources, or secondary, i.e., those produced from previous used or processed materials. These sources can be recycled from construction and demolition waste or re-used from industrial by-products such as waste sands from industrial mineral production, and fly ash and slags from coal and metal processes.

40% of aggregates are used in their natural or unbound state, such as gravel or sand, with a further 25% and 15% being used, respectively, in ready-mixed and precast concrete [52].

Different types of aggregates include:

- Gravel

This is typically a hard rock that has either been crushed and screened by the manufacturer, or river rock ground into uniform size by water action, comminution, and water flows, over thousands of years. Typical size ranges are from 5- 30 mm.

- Sand

Sands are naturally occurring silicon dioxide or quartz particles. They are extracted from the sediments of rivers and seas. Different grades include:

- Sharp Sand: Used for slab laying and block paving (0-4mm used at a time)
- Washed Recycled Sharp Sand: For block paving and slab laying
- 0-4mm Reject Sand: This is used for pipe blending
- Building Sand: Used for laying brick and block work, paving slabs, etc.
- Play Sand: For sandpits used by children
- Soft Washed Sand: For block work and rendering

- Crushed concrete (recycled waste material)

This is made from concrete demolition waste and may be of variable sourcing and quality. It is used in base constructions and landfill. However, recent advances in the sorting and refining of recycled aggregates is moving them higher up the supply chain and into more demanding applications such as precast concrete.

- Secondary aggregates from industrial processes (reused waste material)

These may come from many industrial sources. For example, granite aggregates are being produced from “stent”, the waste sand residue from the production of China clay [53]. This

yields a high quality; consistent product finding uses outside of the traditional construction markets and into high polished furniture and fitments.

### 2.3.2 The aggregate industry in Europe

Due to environmental restriction in many countries in the European Union, such as the Netherlands and Denmark, opening new landfills is no longer permitted, which has led to a strong trend in finding alternative solutions for using their waste materials [52].

With the continued urbanization of most major European countries the aggregate industries, currently valued at around 18 billion USD is expected to see growth more than 4% year per year [54], with Germany expected to lead the way in the construction boom. This will be partly driven by a greater demand for high rise buildings requiring both foundation and construction materials.

Most of the market is supplied by crushed rock and stone produced from quarries and used for concrete and asphalts as well as foundations and drainage systems. However, with the increased pressure on primary raw materials the largest growth is expected to come from recycled construction waste. Data for aggregate historical demand is available from the European Aggregates Association (uepg.eu). There are several major players in Europe, with continuing consolidation of the market. These include: LafargeHolcim (Switzerland), Heidelberg Cement Group (Germany), Saint-Gobain (France), Effiage Group (France), Aggregate Industries (UK), CRH plc (Ireland), and many others.

The industry expects continued growth per capita for all European countries. Reliance on primary raw materials will continue, although there will be increased pressure on both mining and processing considering the Green Deal being implemented across the European Union. Whilst the aggregate industries support and welcome this development, even with the complete reuse of demolition and construction waste this would only account for 12-20% of current total demand. The sourcing of other secondary materials, such as those from primary mineral extraction and other industrial by-products, is therefore expected to become more urgent considering future demand.

### 2.3.3 Aggregates from waste and demolished materials

By the increase of the population, the volume of waste production has been increasing correspondingly. Besides the increase of CO<sub>2</sub> production, the demand for the increase of production has resulted in enhancement of waste material deposit, which is highly affecting the environment, especially those which are non-degradable. Due to this issue, the disposal crisis will be arisen and bigger disposal sites will be required, utilizing these waste materials as raw materials for specific industries can not only decrease the volume of non-disposal waste deposits, but also conserves natural resources extracted from the raw materials [55][56]. The construction sector in Europe is the biggest producer of waste in comparison with other industrial areas, responsible for 35% of total waste produced [57]. Construction and demolition waste (CDW), consisting of materials such as concrete, bricks, roof tiles, ceramics, wood, glass, plastic materials, asphaltic blends, coal tar and tarred products, excavated soil, insulating materials, gypsum and more, is becoming a big issue all over the world. A considerable part of the CDW is used as recycled aggregates in road construction and in the concrete industry, enhancing the circularity in construction.

#### 2.3.3.1 CDW and its processing

The goal of the EU is to achieve a recycling rate of CDW of more than 70%, that has already been achieved today, though actual numbers might differ from source to source. The total CDW in 28 countries of the European union plus Britain, reached more than 368 million tons in 2018 [57]. According to Eurostat 96% of CDW was recycled in 2018, compared to 2012 in which 90% of CDW was recycled shows an increase, and seems to be steadily increasing in the following years [57]. In 2018, produced construction mineral wastes in Germany were over 218.8 million tons of which just

73.3 million tons were recycled [59]. According to the European Environment Agency [58] and as shown in Figure 2-7 among the member states of the EU large differences in the ratio of recycling to landfilling exist. According to these numbers the average recycling rate is 74%, while the maximum potential is identified as 96%. Note that this recycling rate includes CDW used for backfilling which is usually considered as downcycling. An increased use of recycled aggregates from CDW for high-value applications, like concrete production, would therefore help to use this potential [58].

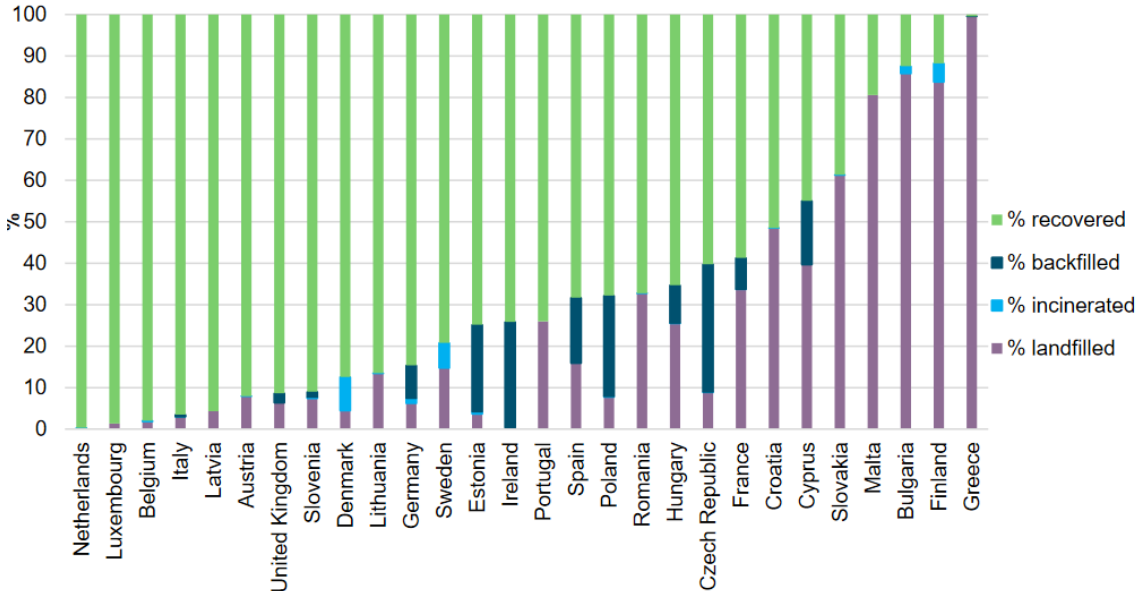

Figure 2-7 CDW production in EU members [58]

Materials which can be used in the construction industry can be divided into three groups including raw and industrial produced materials, secondary raw materials (which are the waste materials taken from other industries) and recycled demolished construction materials which are taken after destruction and demolishing of current structures by applying a specific process, or without processing [60][61]. Figure 2-8 shows the destruction steps of an ordinary building by which the different materials could be extracted separately.

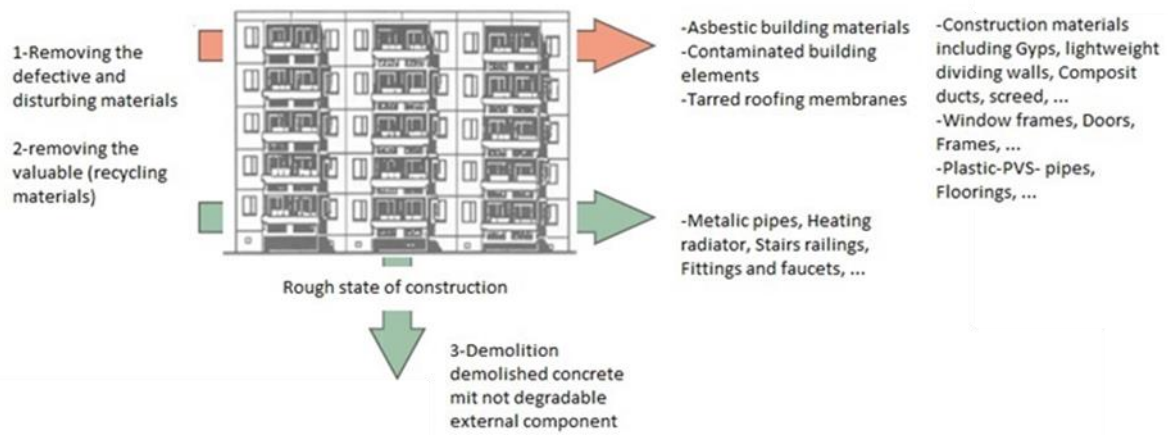

Figure 2-8 Selective deconstruction of a residential building by removing the components [61]

The cost of recycling plays an important role on the feasibility of the selection of the recycling method. The sketch in Figure 2-9 demonstrates the overview of construction and demolishing of the buildings in terms of traditional and modern recycling approach. Figure 2-10 also demonstrates the circulation of construction materials from raw state to disposal or reuse.

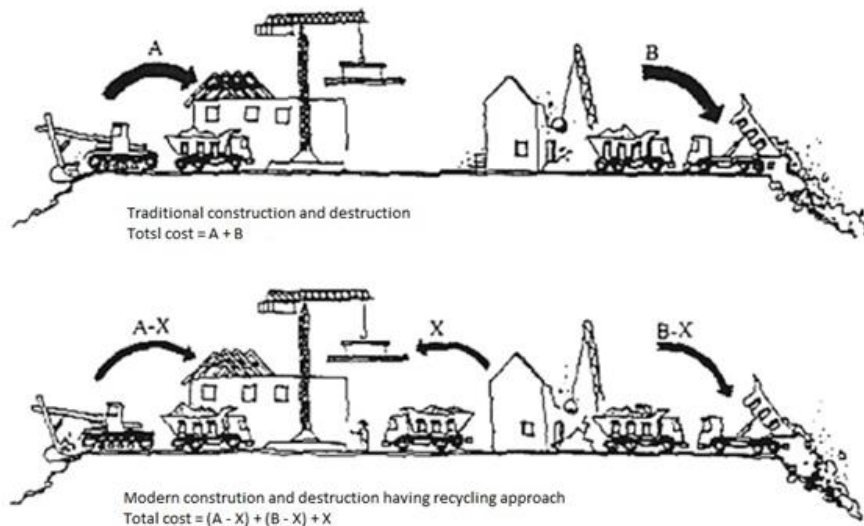

Figure 2-9 The traditional and modern construction and deconstruction [60][61]

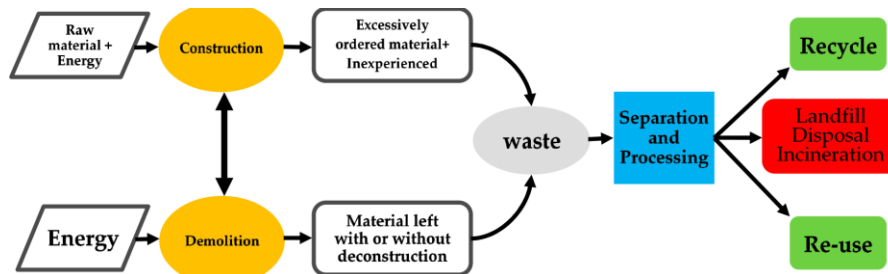

Figure 2-10 Circulation of construction materials (adapted from [62])

For recycling the demolished construction materials, the crushing and grading process is playing an important role. The suitable process can provide proper materials for the bearing layer of the road or for using in the concrete production as aggregates. The sketches of four types of common crushers that are used in aggregate production are represented in Figure 2-11 (a) Swing-in jaw crusher, (b) Impact crusher, (c) Impact-roll crusher, (d) Cone crusher. The sieving process must be subsequently carried out to provide proper grading of the aggregates. For sieving, there are several types of machines for grading the crushed materials. Rolled grid and fixed grid are the most common sieving systems.

In recycling demolished construction materials, sorting the remaining materials is playing an important role on the categorization of the extracted deposit. For this purpose, the density of the waste is the key property that helps us to separate the materials having different properties. Two ordinary methods for sorting the demolished materials are dried procedure and wet procedure, that are shown in Figure 2-12. In wet procedure, the materials are being separated due to the difference of their density and the density of fluid which is usually water for construction materials. It means that, the lighter materials are floating and those having higher density than water are settled due to dominant gravitational force. Using the water stream in this procedure helps better categorize the light materials. On the other hand, in dry procedure, the materials must have close size grading and the particles must be singular.

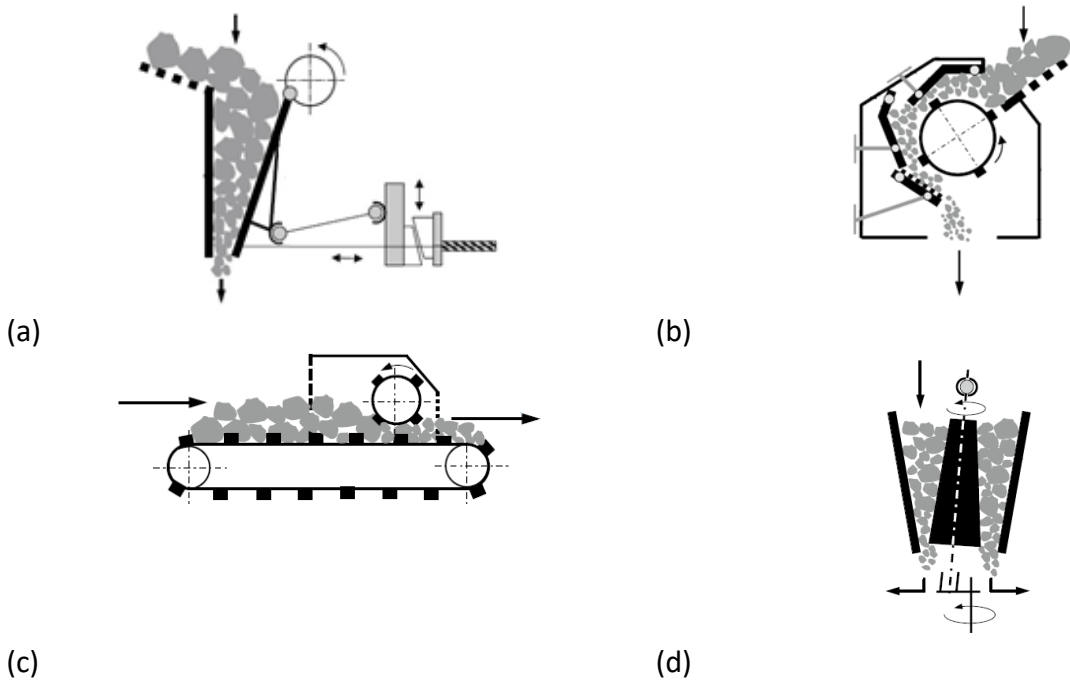

Figure 2-11 The sketches of the four most popular aggregates crushers (a) Swing-in jaw crusher, (b) Impact crusher, (c) Impact-roll crusher, (d) Cone crusher [61]

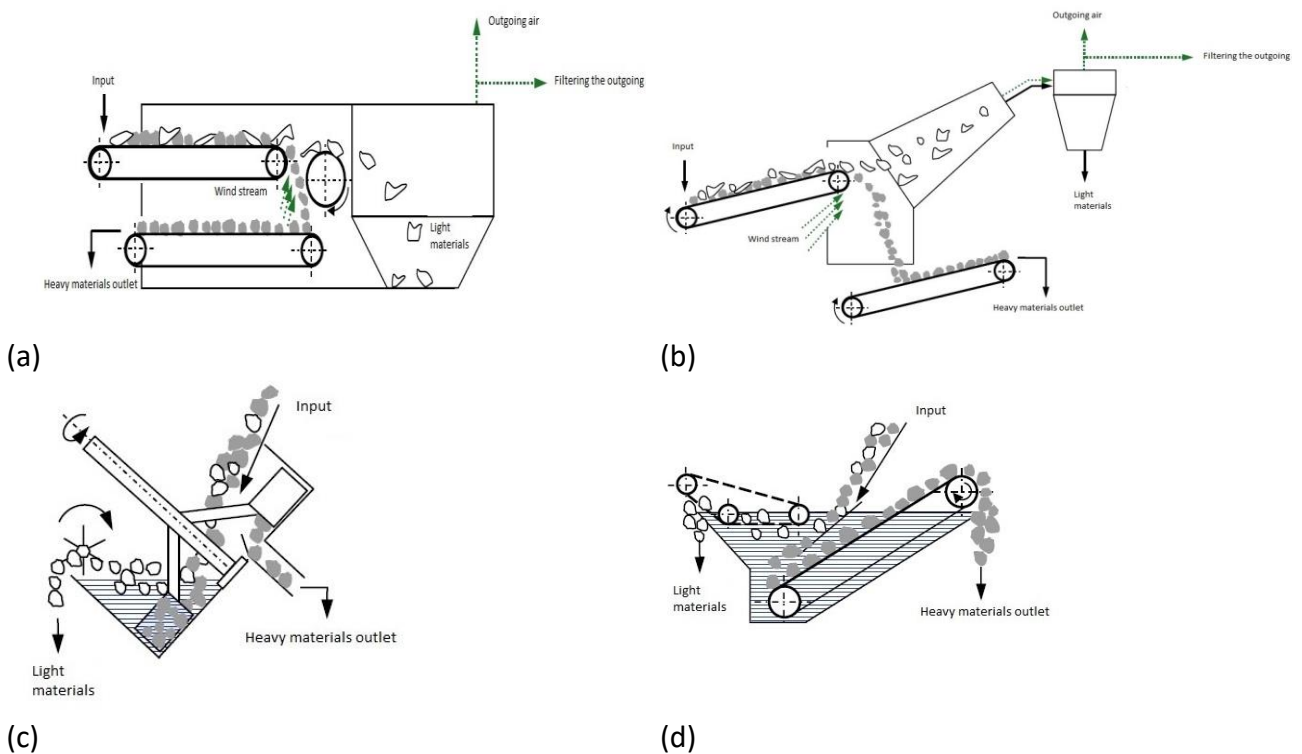

Figure 2-12 Sketches of two dried sorting machines for demolished materials (1st and 2nd) and two wet sorting machines (3rd and 4th) [61]

Due to the higher volume of concrete production all over the world, the efforts for using the non-decomposable and demolished materials in concrete increased. In the concrete industry  $\frac{3}{4}$  of the



concrete volume is filled with aggregates [56][63]. Therefore, non-reactive materials having proper strength and durability could be replaced by natural ordinary aggregates. Demolished concrete, plastic, glass, coconut shell and agricultural farming wastes could be the alternatives for aggregates and fillers [56][63][64]. On the other hand, the other types of waste materials, those including binding behaviour or having the possibility to be applied as processed binders, can be replaced with contemporary binders. The recycled aggregates absorb a higher amount of water in comparison to natural aggregates. This water absorption rate is time dependent.

Recycled brick and masonry are assigning considerable amounts of construction demolished materials. In Figure 2-13, the annual production of materials for building walls is illustrated. The sketch of composition and production of these masonry materials can be observed in Figure 2-14. The fine recycled brick can be used to produce alkali-activated brick by using just fine aggregates or a mixture of fine and coarse aggregates. Exemplary data on recycled aggregates components associated cold asphalt can be found in [69].

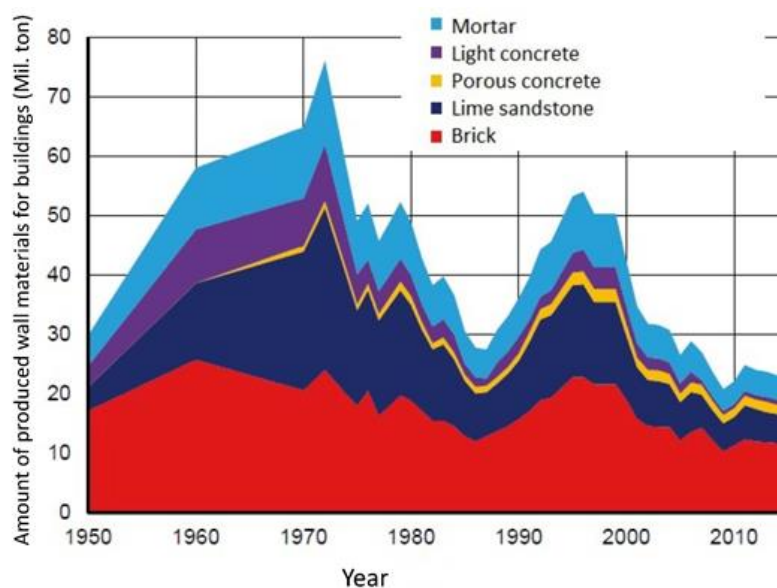

Figure 2-13 Annual production of masonry materials in Germany [61][66]-[68]

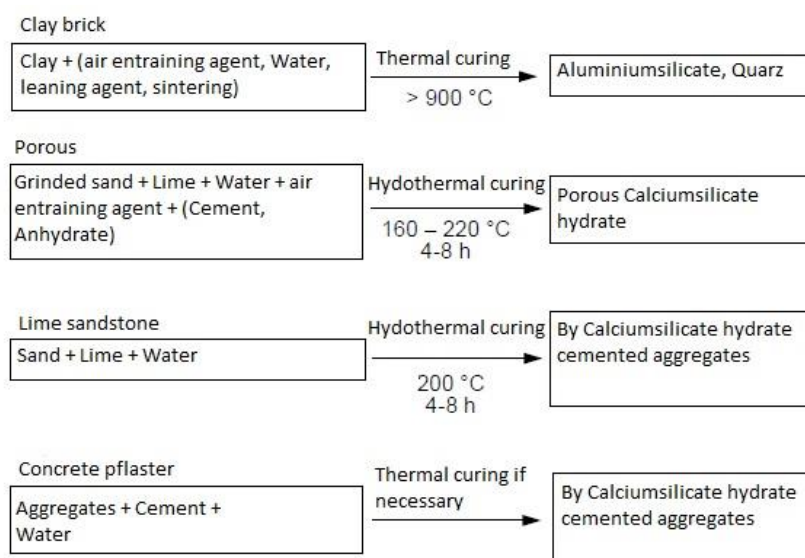

Figure 2-14 Comprehensive masonry materials scheme [65]



### 2.3.3.2 Using CDW as recycled aggregate in concrete

Basically, Portland cement concrete is considered as three-phase material consisting of aggregates, paste and interfacial transition zone (ITZ). On the other hand, recycled aggregates are composed of two phases including old aggregates and old mortar paste in contrary to ordinary natural aggregates that have just one phase. Therefore, using recycled concrete aggregates (RCA) increases the material phases, and consequently, results in different matrix in meso-level structure and different failure mechanism in compression. Thus, the standard procedures for ordinary concrete with natural aggregates cannot be properly adopted to the designing requirements and new prediction models for physical, as well as mechanical behaviour of recycled aggregates concrete [52].

Within the URBCON and DuRSAAM projects, CDW has been successfully used in alkali-activated concrete mixtures, as well URBCON concrete has been crushed to review its use as future recycled aggregates. The quality of recycled aggregates in terms of components they contain can be classified according to DIN 4226-101, considering four types as presented in Table 2-3. For concrete production, types 1 and 2 may be considered according to DIN 1045-2. These categories are partly different from those defined as type A and B in EN 206. The CDW to be used as aggregate is typically evaluated by several properties (and corresponding EN test standard), among which particle size distribution (sieving method) EN 933-1, loose bulk density and voids EN 1097-3, particle density EN 1097-6, water absorption EN 1097-6, flakiness index EN 933-3 and shape index EN 933-4.

Table 2-3 Categories of recycled aggregates according to DIN 4226-101

	Component	Type 1	Type 2	Type 3	Type 4
1	Rc+ Ru	> 90%	> 70%	< 20%	Rc+Ru+Rb> 80%
2	Rb	< 10%	< 30%	> 80%	
3	Ra	< 1%	< 1%	< 1%	< 20%
4	X+Rg	< 1%	< 2%	< 2%	< 2%
5	FL	< 2%	< 2%	< 2%	< 5%

Rc: concrete, mortar, concrete products; Ru: separated aggregates, natural stone, hydraulic sticked aggregates; Rb: brick, limestone blocks, various bricks and blocks of the roofs, light weight concrete and mortar, not floating porous concrete; Ra: bituminous materials, asphalt; Rg: glass; X: other materials (bound materials, (soil and clay from the earth), metals, not floating woods, synthetic materials, Rubber, Gypsum); FL: floating materials

Four kinds of recycled aggregates were considered in the developed paste mixtures of the URBCON project for evaluation of their effects on the upscaled mixtures at concrete level (Table 2-4). In addition, recycling the produced concretes in the URBCON project was tested for the life cycle assessment of URBCON technology by using them as aggregates.

Table 2-4 The sorts of recycled aggregates used in URBCON project

	Type (According to Table 2-3)	Size	Materials
1	1	0/2 mm	Recycled concrete
2	1	2/8 mm	Recycled concrete
3	1	8/16 mm	Recycled concrete
4	2	2/16 mm	Recycled concrete, Brick

Figure 2-15 illustrates the grading of natural aggregates, as well as recycled aggregates which were used in the concrete mixtures. Apart from the grading, the physical properties of mentioned aggregates can be seen in Table 2-5. The natural aggregates having the grading of 8/16 mm, 2/8 mm and 0/2 mm are shown in Figure 2-16 a-c, respectively. The recycled aggregates type 1 having the grading of 8/16 mm, 2/8 mm and 0/2 mm are demonstrated in Figure 2-16 d-f. Figure 2-16 g also shows the recycled aggregate type 2, having 2/16 mm grading.

The grading of the combination of different aggregates in the mix design for particle size analysis are illustrated in Figure 2-17 till Figure 2-19. The Figure 2-17 illustrates 100% natural aggregates, while Figure 2-18 represents 70% of recycled aggregates Type 1 having the grading of 2/8 and 8/16 mm and 30% natural aggregates in the range of 0/2 mm size. The grading of aggregates in which 100% recycled aggregates were utilized are visualized in Figure 2-19. It shows better performance in terms of gap grading than the combination of 70% recycled aggregates with 30% natural aggregates shown in Figure 2-18. These gradings target predefined optimal grading curves for concrete, such as provided in DIN 1045-2. Hereby a coarse to medium grade has been targeted and achieved, even though it can be considered gap graded in the 2/5 mm range.

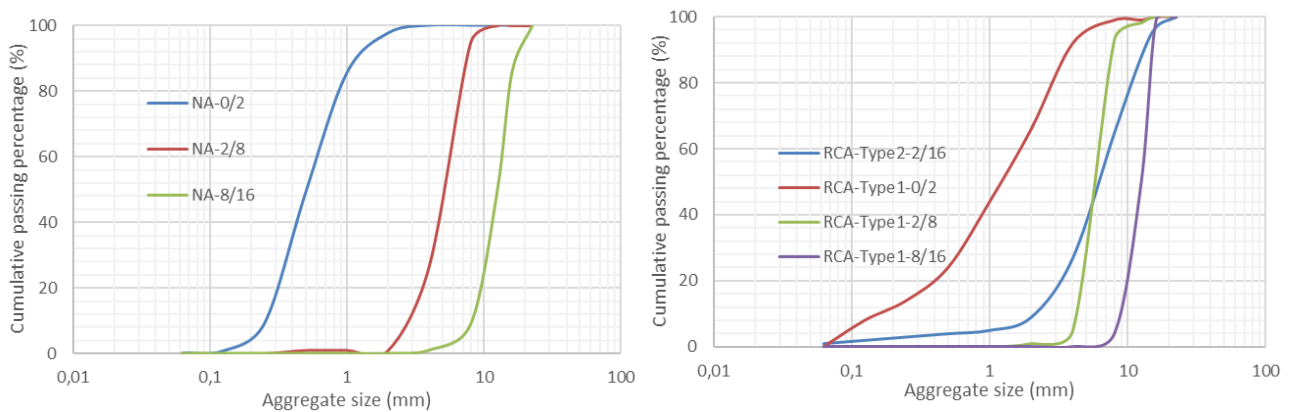

Figure 2-15 Particle size distribution of natural (left) and recycled aggregates (right)

Table 2-5 The physical properties of recycled aggregates

Properties	Unit	NA 0/2 mm	NA 2/8 mm	NA 8/16 mm	RCAT1 2/8 mm	RCAT1 8/16 mm	RCAT2 2/16 mm
Flakiness Index (DIN EN 933-3)	FI [-]	-	10	13	10	5	9
Shape Index (DIN EN 933-4)	SI [-]	-	3.93	17.5	12.87	5.91	13.37
Loose Bulk Density (DIN EN 1097-3)	$\rho_b$ [Mg/m <sup>3</sup> ]	-	1006	1000	1304	1274	1233
Particle Density (DIN EN 1097-6)	$\rho_a$ [Mg/m <sup>3</sup> ]	2.644	2.66	2.60	2.78	2.7	2.63
	$\rho_{rd}$ [Mg/m <sup>3</sup> ]	2.616	-	-	2.49	2.48	2.20
	$\rho_{ssd}$ [Mg/m <sup>3</sup> ]	2.627	-	-	2.59	2.56	2.31
Water Absorption after 24h (DIN EN 1097-6)	WA <sub>24</sub> [%]	0.40	1.08	1.30	4.22	3.24	9.21



Figure 2-16 Natural (a-c) and recycled aggregates (d-g) used in the URBCON project (courtesy RPTU)

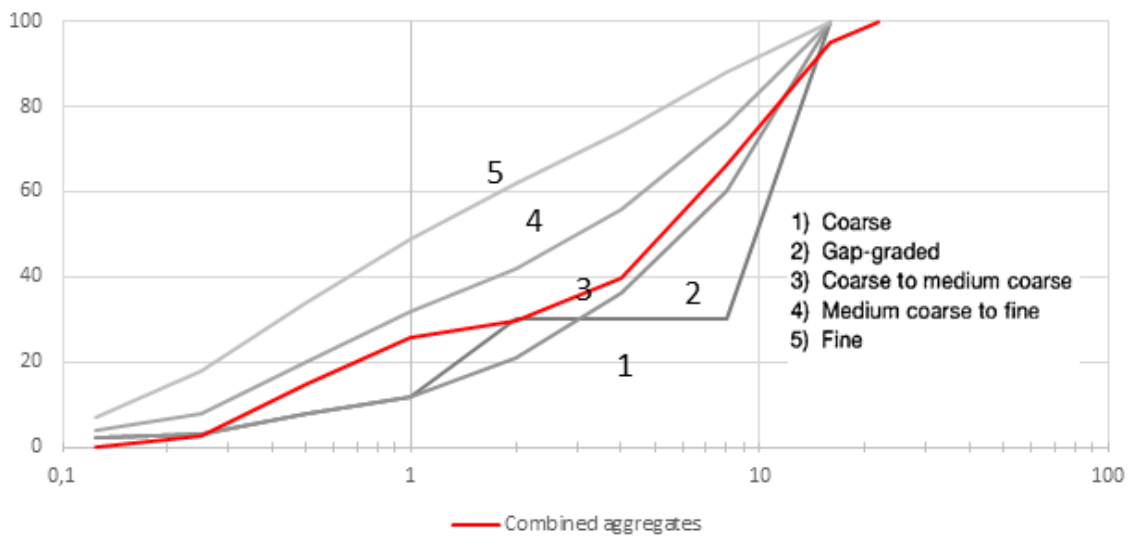

Figure 2-17 Grading of combined natural aggregates used in alkali-activated concrete mixtures

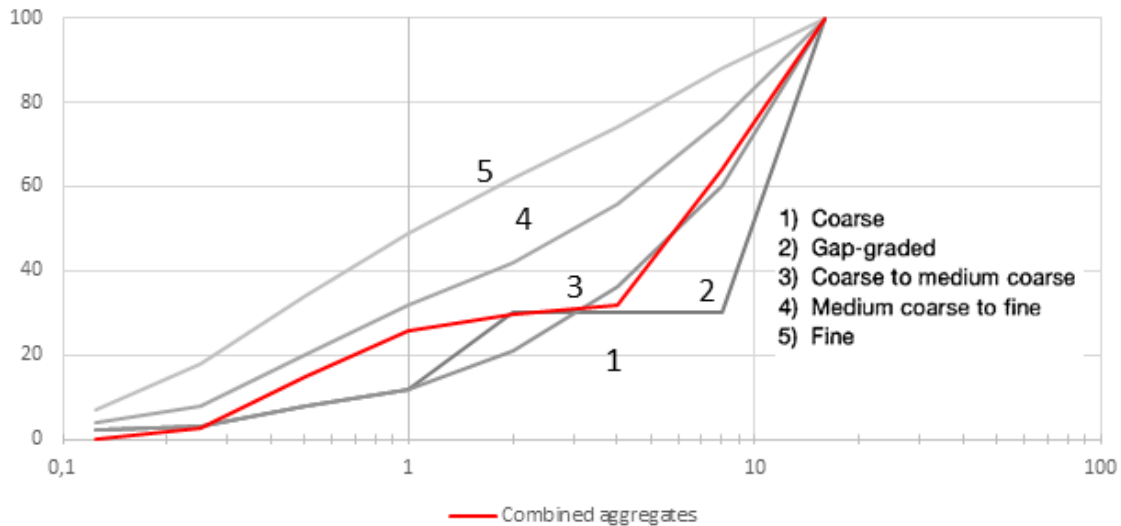

Figure 2-18 Grading of combined 70% recycled aggregates and 30% natural aggregates used in alkali-activated concrete mixtures

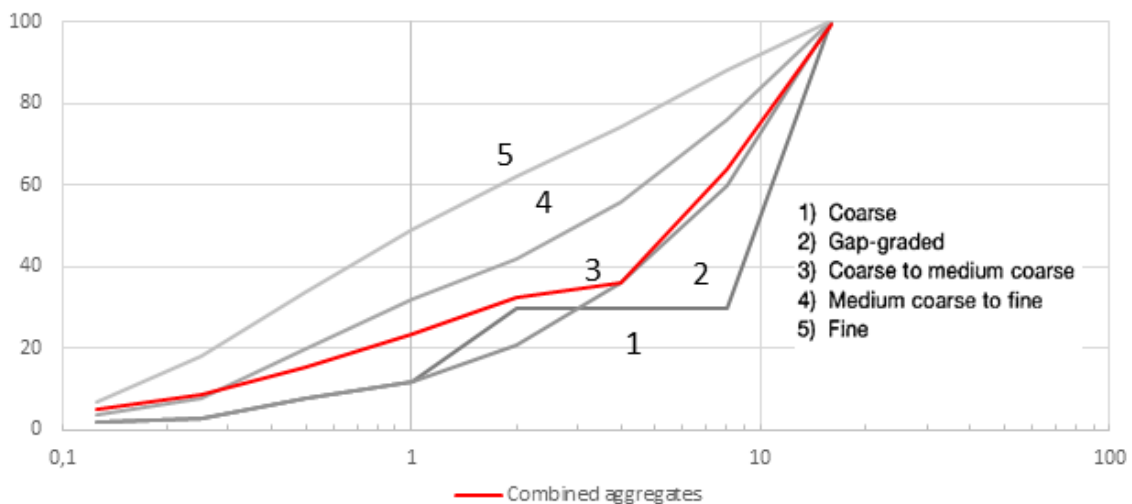

Figure 2-19 Grading of combined recycled aggregates used in alkali-activated concrete mixtures

One of the further tasks in the URBCON project was to investigate the possibility of reusing URBCON concrete after their service-life as recycled aggregates. Therefore, two reinforced concrete slabs, made from alkali-activated concrete produced with either natural or recycled aggregates, were crushed after obtaining their targeted strength. This crushed material (Figure 2-20) was used to successfully make new alkali-activated concrete. The grading of the reused URBCON aggregates combined with 30% natural 0/2 mm fine aggregates are demonstrated in Figure 2-21 and Figure 2-22. They correspond to the aggregates obtained from alkali-activated concrete made by natural aggregates and by 70% recycled aggregates type 1, respectively.

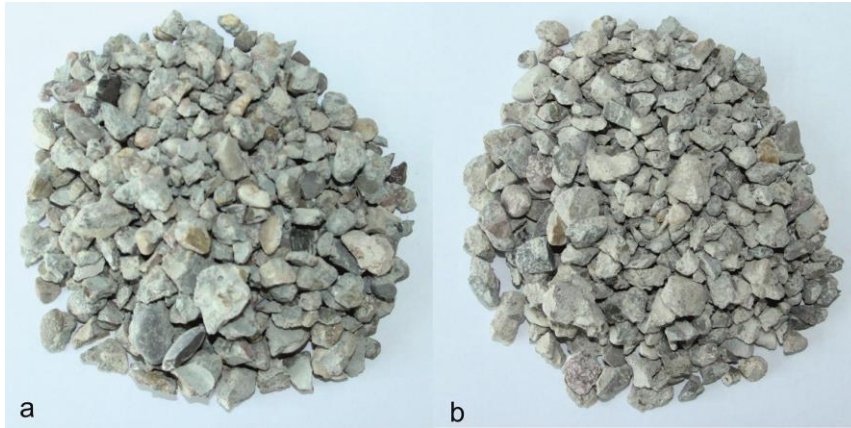

Figure 2-20 Recycled aggregates extracted from URBCON-concrete slabs. (a) URBCON-concrete made by natural aggregates (b) URBCON-concrete made by recycled aggregates type 1

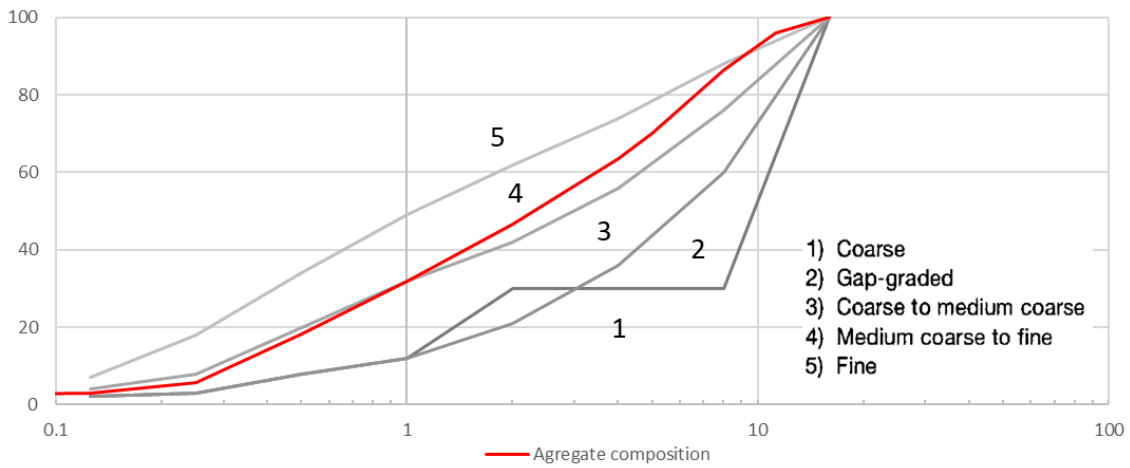

Figure 2-21 Grading of combined URBCON recycled aggregates (whereby the recycled aggregates came for URBCON concrete produced with 100% natural aggregates)

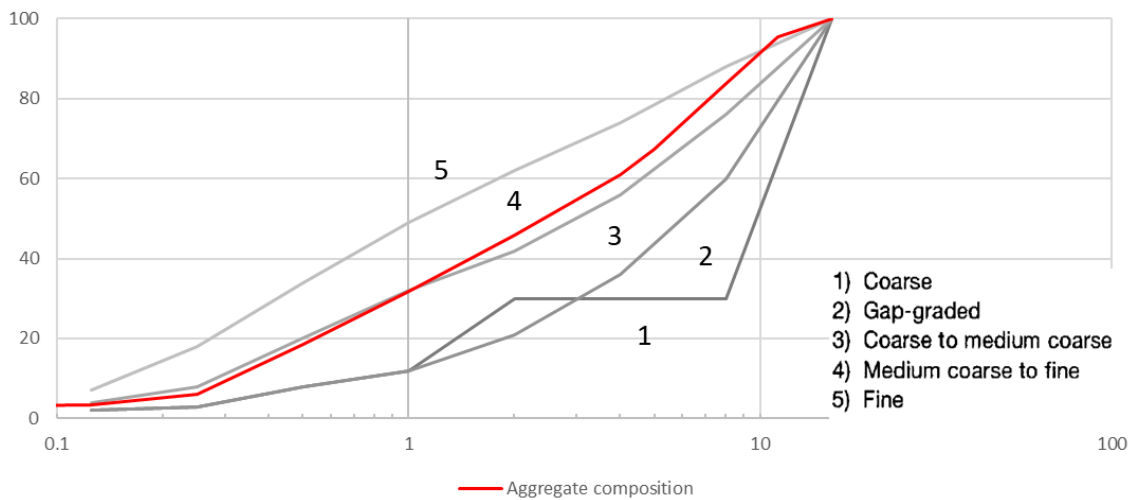

Figure 2-22 Grading of combined URBCON recycled aggregates (whereby the recycled aggregates came for URBCON concrete produced with 70% recycled concrete coarse aggregates)



The recycled URBCON concrete aggregates showed significantly higher water absorption than natural and reference recycled concrete aggregates. In contrary, the dried density of the recycled URBCON concrete aggregates does not show specific changes in comparison to the primary natural and recycled concrete aggregates. Using recycled aggregates, typically with higher water absorption than natural aggregates, affects the fresh concrete behaviour. In order to provide exact W/B (water to binder) ratio in all mixtures during the URBCON project, all recycled aggregates were dried before concrete production, cooled in room temperature until they reached the  $20\pm 2^\circ\text{C}$  and remained in the mixer for 10 minutes with an amount of water required for saturation (total water absorption after 24 hours) before mixing procedure of concrete, in order to prevent slump loss after production as well as absorption of alkali solution. A similar procedure can be done in practice without drying the recycled aggregates and measuring the moist content (as commonly done in concrete plants to adjust the water dosing).

It was observed that the URBCON concrete aggregates have no considerable effect on the fresh properties of alkali-activated concrete. The effect of these aggregates on the hardened properties of concrete were like the ordinary crushed concrete aggregate, except for the modulus of elasticity, which decreased up to 50% for both types of URBCON concrete aggregates in comparison to behaviour of their corresponding concrete made by recycled aggregates type 1 and natural one. A decrease in elastic modulus by 20% when replacing 100% of the coarse aggregates by recycled concrete aggregates has been found e.g., in this study [70]. Replacement of fine natural aggregates by recycled ones or using recycled aggregates type 2 can also result in a lower value of elastic modulus [70].

## 2.4 By-products for use as construction minerals and their processing

As highlighted in the previous two sections on binders and aggregates in concrete, next to the use of recycled construction and demolition waste, by-products are of increasing interest to avoid the use of primary raw materials from Mother Earth. This to minimize the use of primary excavated materials as construction minerals for concrete and rather to reuse by-products generated from other industrial activities (including construction and demolition waste industry, but also in reference to other industries such as metallurgy and combustion-to-energy). An overview of binder and aggregate replacing materials is given in Figure 2-1. Further to the overview given in this section, also reference is made to Section 3.3, providing a specific discussion of by-products for alkali-activated binders.

### 2.4.1 Industrial waste and by-products

Significantly large volumes of by-products, that are of mineral nature, result from different industrial activities. Amongst other reference can be made to metallurgic processes, combustion-to-energy processes, and mining processes. To provide a comprehensive overview of these processes, the resulting by-products, and their nature, as well as the treatment of these by-products into raw materials as construction minerals, would be beyond the scope of this document. Rather, a discussion is provided in the following subsection that are exemplary for the generation and use of by-products in the context of construction minerals.

#### 2.4.1.1 Metallurgic slags, discussed by means of steelmaking slags

As by-product of metallurgic processes, such as used for steelmaking, different kinds of metallurgic slags are available. ArcelorMittal, a world leading steel company, has been proactive in using its waste materials. Overall, the steel industry achieves a material efficiency rate of 97.6% and is moving towards a goal of 100% efficiency and zero waste. The main by-products from the steelmaking process are slag, process gases, and dusts and sludges. The coking process also produces a range of

chemicals such as ammonia, sulphur and naphtha that are all sold commercially. ArcelorMittal operates a hierarchy for managing steelmaking residues that works towards its goal of zero non-hazardous waste to landfill [71].

During steel production a range of by-products are created. These are either fed back into the steelmaking process to make it more efficient or they are reused. Iron and steelmaking slags are widely reused in bituminous mixtures for roads, in cement and concrete and in soil stabilisation. In reference to cement and concrete, depending on their chemical and physical characteristics they are used as binders or as fine and coarse aggregates. After treatment (such as metal recovery), crushing and sieving the slags can be as a secondary aggregate. After further grinding of the slags to powder shape, they might also be used as SCM and as precursor for AAM. Exemplary for the latter is ground granulated blast furnace slag (GGBFS).

In the following a more general and non-exhaustive overview is given on the production of several slags, the treatment to recover iron and to handle the slag into a correct shape for further use, and finally the known applications. Hereby, reference is made to use abbreviations as listed in Table 2-6.

Table 2-6 Abbreviations

BF	Blast Furnace	SMS	Secondary Metallurgical Slags
ABS	Air cooled Blast Furnace Slag	HM	Hot Metal (Pig Iron)
GBS	Granulated Blast Furnace slag (can be abbreviated both as GBS and GBFS)	EAF	Electric Arc Furnace
BOF	Basic Oxygen Furnace	SP	Sinter Plant
BOS	Basic Oxygen Slag	MRP	Metal Recovery Plant

### Production of metallurgic slag illustrated by means of steelmaking with a blast furnace

To discuss the various metallurgic processes would be out of scope for this e-handbook. As a good example of how slags result from metallurgic processes, one can look closer to the typical process of steelmaking by means of a blast furnace. The process flow is illustrated in Figure 2-23, highlighting the main origin of slags in this industrial steelmaking process.

Three origins of slags can be identified in this process:

- 1) **Blast furnace (BF) slag.** Separation of BF slag and hot metal (HM) is controlled by density differences between both streams  $2\text{T/m}^3$  for slag and  $7\text{T/m}^3$  for HM. HM is cast into open ladles or torpedo vessels, which is the basic product used in the steel shop for transformation into liquid steel. Next to the HM, liquid slag is tapped from the BF, by one of 2 methods, resulting in two distinct products:
  - The basic product is **granulated blast furnace slag (GBS)**, Figure 2-24, that is created when the liquid slag is tapped via a runner to a drum and sprayed with a high volume of water. Per ton of steel product, on average approximately 260 kg of granulated blast furnace slag are produced. A slag with a glassy structure is formed and the “sandy” material (grainsize  $< 5\text{ mm}$ ) is evacuated by conveyor belts to a storage pad. This storage pad is set up for the dewatering of the GBS. This is a standard practice called INBA system, although spraying high volumes of water under pressure on the liquid slag coming into a reservoir, is still going on in some plants.
  - The alternative product is **air cooled blast furnace slag (ABS)** that is created by being cast into a pitch or drainage basin and is cooling in air with addition of water. When cooled, the basin is emptied using a loading shovel, and transported to the stock yard, ready for further processing.



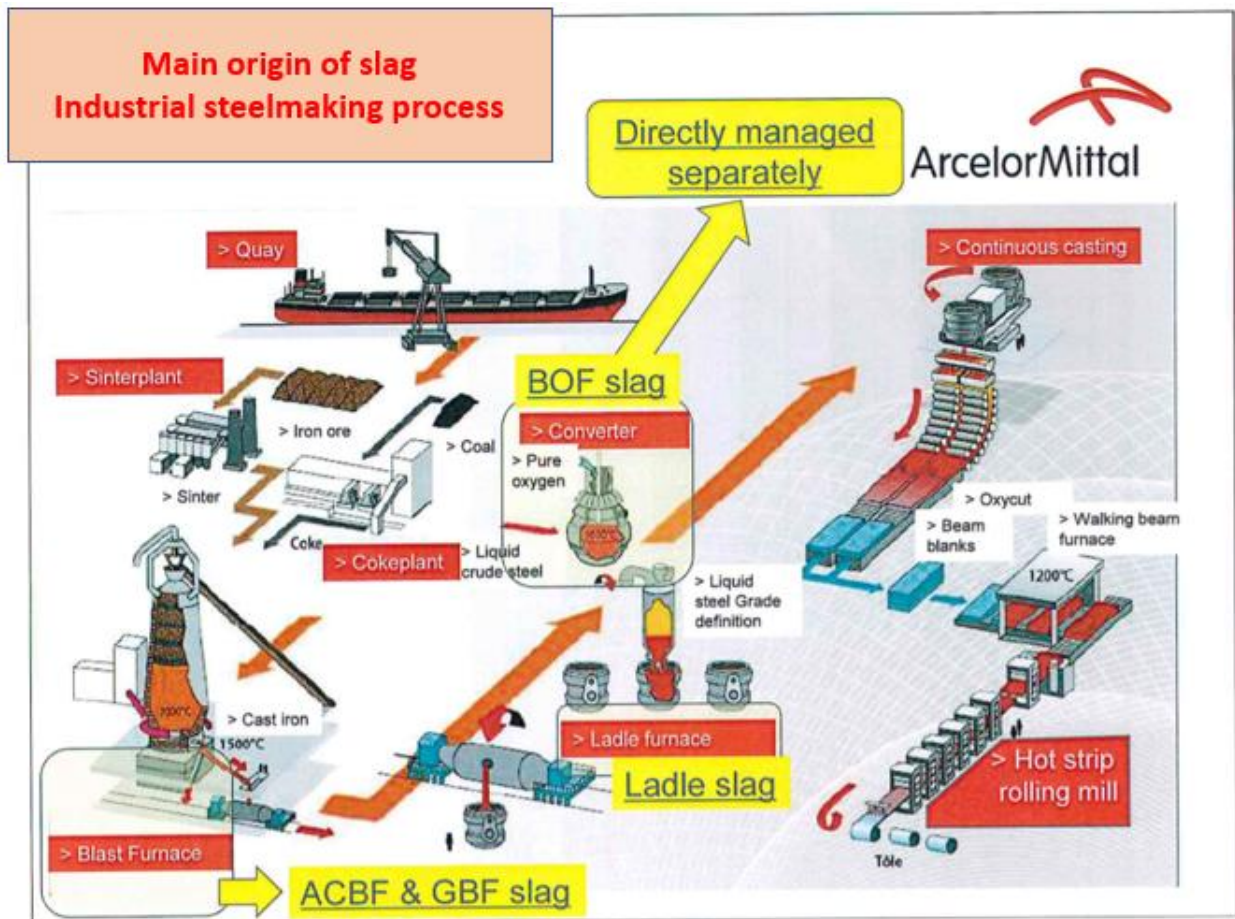

Figure 2-23 Process flow of steelmaking and main origin of slags in this process

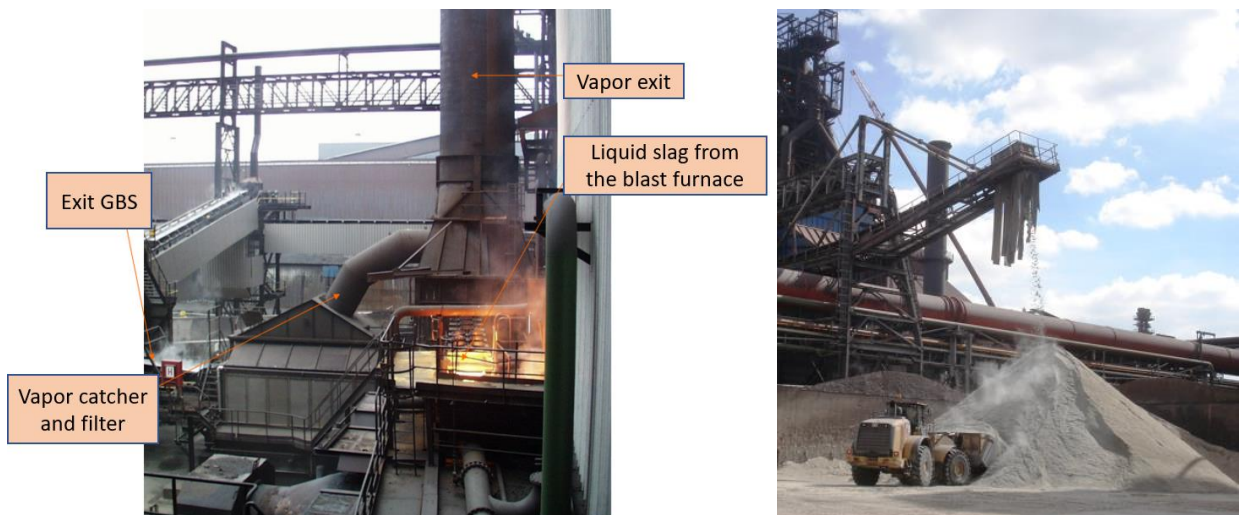

Figure 2-24 Slag granulation unit ex-blast furnace (left) and storing GBS (right)

2) **Steel slag (BOS).** During the oxidation process (Linz-Donawitz (LD) process) in the basic oxygen furnace (BOF), the transformation of liquid iron (HM), to liquid steel requires the generation of a slag to remove impurities. This basic oxygen slag (BOS slag) ( $3.3 \text{ T/m}^3$ ) is lighter than liquid steel ( $7.6 \text{ T/m}^3$ ) and floats on top of the molten bath. After tapping the liquid steel in the steel ladle, the converter is turning the opposite way, to cast the liquid slag into the slag pot. This

liquid slag is transported to a stockyard, where it is poured in the slag pit, where water is sprayed to assist cooling. The solid slag is then removed using a front-end loading shovel and stored for further processing.

- 3) **Ladle slag (secondary metallurgic slag, SMS).** Once the steel has been tapped into the steel ladle, further slag is formed to refine the steel further into different grades. At the end of this secondary metallurgical process the steel is tapped into the continuous caster, and the ladle slag is casted in a slag pot. These slags are processed the same way as BOF slag, poured out in the slag pit. After cooling down, the slag can be further processed.

Complementary, in the process of melting steel scrap in an electric arc furnace (EAF), once the steel has been tapped into the steel ladle, the slag is tapped onto the floor where it is removed using a specially modified loading shovel, or into a steel pot and transported to the slag pits, where it is cooled in air, assisted by water sprays. Once cooled it is taken out to the pits for further processing.

An overview of these slags and their EINECS (European Inventory of Existing Chemical Substances) number is given in [Table 2-7](#). An example of a typical composition of GBS, ABS and BOS is given in [Table 2-8](#).

### Processing of slags

The main mission of companies who process slag, is the recovery of metals from metallurgic slags, which has a high value, and that can be recycled in the production of metals (avoiding primary ores).

*Table 2-7 List of ferrous slags and their denominations*

Family no.	Substance for registration	EINECS name	Common name	EINECS no. CAS no.
1	GBS	Slag, ferrous metal, blast furnace (granulated)	Granulated Blast furnace Slag	266-002-0 65996-69-2
	ABS	Slag, ferrous metal, blast furnace ( air-cooled)	Air-cooled Blast Furnace Slag	266-002-0 65996-69-2
2	BOS	Slag , steelmaking, convertor	Basic Oxygen Furnace Slag (converter slag)	294-409-3 91722-09-7
3	EAF C	Slag, steelmaking, elec. furnace (carbon steel production)	Electric Arc Furnace slag (from carbon steel production)	932-275-6 -
4	EAF S	Slag, steelmaking, elec. furnace (stainless/high alloy steel production)	Electric Arc Furnace slag (from stainless/high alloy steel production)	932-476-9 -
5	SMS	Slag, steelmaking	Steelmaking slag	266-004-1 65996-71-6

*Table 2-8 Typical chemical composition (in %) of GBS/ABS and BOS*

	CaO	MgO	SiO <sub>2</sub>	MnO	Al <sub>2</sub> O <sub>3</sub>	FeO	K <sub>2</sub> O	S	NaO	TiO <sub>2</sub>	Free CaO	Other
GBS/ABS	41.9	8.3	35.7	0.2	10.5	0.24	0.43	< 1	0.31	0.82		~ 1
BOS	49.9	4.5	11.4	3.2	2.0	17.5		< 1			12.9	~ 10

\* Other: minor fractions, for BOS mainly P<sub>2</sub>O<sub>5</sub> and some Cr<sub>2</sub>O<sub>3</sub>, V<sub>2</sub>O<sub>5</sub>, MoO<sub>3</sub>

In reference to the steelmaking, the quantity of recovered iron from GBS is very low, and not undertaken in the steel shop site. This separation is mainly done afterwards by granulated ground blast furnace slag (GGBFS) providers, by magnetic separation to protect the mills used to grind the GBS into GGBS. The output is less than 0.3 kg/T GBS. The recovery of the iron from the ABS is achieved in the steelmaking site via a metal recovery plant (MRP), by magnetic separation from the slag. During this process iron and slag are separated, and a first sieving and/or crushing is completed with sieves and crushers in several standard dimensions. Depending on the final sizes of the slags required for different applications, further crushing can be required, either in the MRP or afterwards with a mobile crusher, to achieve the correct size fractions. An example of possible sizes (in mm) is 0-32, 14-32, 0-60, 32-60, 60-180, 32/90, 90/300 for ABS, though for GBS often only available in fractions below 6 mm.

The treatment of BOS is done through the MRP. Here the metal is separated by magnetic drums, and both the metal and demetalled slag are sieved into different sizes. The size of the recovered metal is considered as a function of internal usage (in the sinter plant (SP), blast furnace (BF) or basic oxygen furnace (BOF)). The remaining slag after metal recovery is sized (sieving and crushing) in standard fractions, or tailor-requested grain size fractions if required. Their use can be internally for reuse in the process of SP, BF or BOF, or externally to be sold). The storage of BOS is generally accommodated on site. As a demonstration of good housekeeping, the stockpiles are well marked with name, size and starting date. This is needed, as some slags need to be “fresh” (where the free lime is used as an activator), or “aged” to reduce the fines and to reduce the free lime activity, to limit the swelling (potential expansion).

The treatment of ladle slag (SMS) is again done through the MRP. Here the metal is also separated by magnetic drums, and both the metal and the demetalled slags are processed in several different sizes, as discussed for the case of BOS.

Also, EAF slags can be processed in the MRP in a similar way, to obtain demetalled slag.

In reference to slags in the MRP that are not (fully) suited for magnetic separation, the so-called stainless slags, the separation can be achieved by either a water floating system (type JIG) or by milling and further density separation using spirals.

### **Use of the (treated) slags, among which for cement replacement**

The use of metallurgic slags is always dependent on approvals given by the local authorities. Meaning the status of the product, in terms of waste or by-product, is different by country or even region, where the slags gain approval for a particular application. To bring the slags on the market, 4 essential conditions need to be met:

1. Technical-chemical elements to meet environmental and civil technical restrictions
2. Optimized logistics
3. Legal status
4. Total cost of ownership – commercial

Whereas it is impossible to give all potential applications, within this framework of legal or environmental restrictions and technical know-how, in the following a summary is provided of main applications for the steelmaking slags discussed above. Such applications result in declarations of performance (DoP) by the companies commercializing the (treated) slags, that are for a specific combination of a slag and application type. An example (in Dutch) of such a DoP, in this case BOS for waterways and dykes, is given in [Figure 2-25](#).

## Prestatieverklaring

Product: LD-staalslakken 45 - 180 mm

- |   |   |
|---|---|
| 1. Identificatiecode  | LD 180 20191210   |
| 2. Gebruikstoepassing   | Grove sortering voor waterbouwkundige werken, zijnde steenbestorting voor bodem- en oeverversterking in kust- en oeverwerken, in grote oppervlakte wateren.   |
| 3. Producent  | ARCELORMITTAL BELGIUM NV site Gent<br>John Kennedylaan 51<br>B-9042 Gent  |
| 4. Naam en contactadres gemachtigde   | Niet van toepassing   |
| 5. Systeem voor de beoordeling en Verificatie van de prestatiebestendigheid | EN 13383-1 (2002) Systeem 2+  |
| 6. Taken van de aangemelde instantie  | SGS INTRON Certificatie: <ul style="list-style-type: none"> <li>• initiële inspectie van de productie-installatie en van de productiecontrole in de fabriek</li> <li>• permanente bewaking, beoordeling en evaluatie van de productiecontrole in de fabriek</li> </ul> uitgevoerd en heeft het conformiteitscertificaat voor de productiecontrole in de fabriek verstrekt.<br>Niet van toepassing |
| 7. Europese Technische beoordeling  |   |
| 8. Aangegeven prestatie   |   |

Essentiële kenmerken	Prestaties	Technische specificaties
Korrelvorm, korrelgrootte, korrel dichtheid	Sortering	45/180 mm
	Categorie	45/180
	Steenstukken met een L/D > 3	LT <sub>A</sub>
	Gemiddelde korrel dichtheid	3,30 Mg/m <sup>3</sup>
Breekweerstand	Druksterkte	CS <sub>40</sub>
Slijtweerstand	Micro-Deval coëfficiënt	M <sub>20</sub> 10
Duurzaamheid	Uiteenvallen van staalslak	DS <sub>A</sub>
	Waterabsorptie	WA <sub>4,5</sub>
	Vorst-dooibestendigheid	FT <sub>40</sub>
	Weerstand tegen zoutkristallisatie	MS <sub>40</sub>
Overige informatie	Voldoet aan de eisen van het Besluit bodemkwaliteit inzake samenstelling en emissie, klasse niet-vormgegeven bouwstof	

9. De prestaties van het in de punten 1 en 2 omschreven product zijn conform de in punt 8 aangegeven prestaties. Deze prestatieverklaring wordt verstrekt onder de verantwoordelijkheid van de in punt 3 vermelde fabrikant.

Gent, 06 december 2019



R. Morsier, hoofd Milieu en Bijproducten

Correspondentieadres:  
 ArcelorMittal Gent  
 John Kennedylaan 51  
 B - 9042 Gent

T +32 (0)9 347 31 11  
 F +32 (0)9 347 49 07  
 www.arcelormittal.com/gent

Zeteladres:  
 ArcelorMittal Belgium NV  
 Keizerlaan 66  
 B - 1000 Brussel  
 BTW BE 0403 106 291 - RPR Brussel

Figure 2-25 Example of “declaration of performance” in the use of BOS slags

GBS is basic material for cementitious component:

- Ground GBS is a main constituent for CEM III type of Portland cement, made by mixing Portland clinker with ground GBS to make a CEM III in the cement plant.

- Ground GBS can also be blended with Portland cement in the concrete mix design, applied in a concrete plant (mimicking pre-packaged CEM III from the cement plant).
- Ground GBS mixed with alkali activator to be used as binder in alkali-activated concrete.
- Applications in road construction, in bound (asphalt) and/or unbound use
- Fertilizer

ABS is a good alternative for natural aggregates and replacing natural sand in industrial applications:

- Road construction, in bound and/or unbound use.
- Basic material as a component in mineral wool production.
- Alternative aggregate to replace lava stone, for drainage application.

BOS after metal separation and a screening process can be used in several applications:

- As fertilizer, depending on the place of application, ground or screened, with respect to the local environmental specifications.
- In road construction, in bound and/or unbound application.
- Substitute for lime in the mix with recycled crushed concrete in road foundation.
- Reinforcement for dykes in waterways.
- Coverings of landfills.
- Substitute for lime in refractory cement.
- Recycling in metallurgical process (ferrous and non-ferrous) in BF.
- Fertilizer.
- Substitute for clinker cement as binder agent.

SMS after metal separation and screening process used in several applications:

- Substitute for aluminium oxide in refractory cement.
- Substitute for aluminium oxide in clinker cement.
- Fertilizer.

EAF slags:

- Use as aggregate in concrete.
- Use as aggregate in asphalt.
- Use in road construction, in unbound conditions.

SMS from EAF:

- Screened and/or crushed used as fertilizer.

EAF stainless slags:

- Use as aggregate in concrete.
- Use as aggregate in asphalt.
- Fine fraction as filler in concrete and mortar.

### **Future availability of GBS**

Like the cement industry, steel production is responsible for a significant amount of worldwide CO<sub>2</sub> emissions. Therefore, the steel industry is developing technologies to minimize these emissions. In principle, two different routes are imaginable [72]: in “Smart carbon usage”, CO<sub>2</sub> emissions from common iron and steelmaking processes (blast furnace and converter) would be captured. The captured CO<sub>2</sub> can be either stored (CCS) or used (CCU). This route would not change the common



processes significantly and therefore, would lead to a stable production of well-known materials as described above (GBS, BOS, ...).

The second route can be summarized as “carbon direct avoidance” [72]. Here, the process of steel production will be changed completely. The general idea is to reduce iron directly by hydrogen or in a first step by natural gas (DRI – direct reduced iron). The DRI (or, if compacted, hot bricked iron - HBI) from this process will then be melted – alone or together with scrap – in a second process. Although the ore which is to be used as raw material will still contain gangue, the resulting slag will be different or even completely different from today’s slags. With a high probability, no GBS as known today will be available in the future. The usability of the new slags for cement or generally binder production will strongly depend on the configuration of the new iron and steelmaking process. Two examples are given in the following.

- One possibility is to integrate the DRI process in a power-operated melting unit [73]. From the slag point of view, this process could lead to a material comparable to well-known GBS. The exact properties are unknown today and will depend strongly on raw materials to be used and the slag processing.
- A second example is given in [74][75]. Here, the DRI production is separated from the melting process. The DRI produced in a first step will be melted together with scrap in an electric arc furnace. The resulting slag will perhaps not necessarily have a composition which is appropriate to form a glass. Therefore, additional slag modifications will be necessary if slag for binder production shall be produced. Moreover, the amount of, for example, heavy metals in the slag will rise significantly compared to today’s GBS.

Summarized, GBS as known today and as used for common CEM II- and CEM III-cements and for geopolymer concretes will not be available in the future. Availability of new slags and especially their physical and chemical properties cannot be foreseen with adequate accuracy now [76].

#### 2.4.1.2 Incineration ashes, discussed by means of hard coal fly ash

From energy generation (also including waste-to-energy) incineration processes, bottom ashes and fly ashes are obtained as a by-product. These exist in various kind, whereby siliceous fly ash (SFA) resulting from hard coal being burned in a coal-fired power plant (Figure 2-26) is a mainstream fly ash used in cement replacement.

##### **Production of hard coal fly ash**

Hard coal fly ash is a fine-grained mineral material that is produced in power plants, collected in silos and used in the construction industry as a high-quality and versatile building material. Its applications range from use in concrete and cement to the production of bricks, fillers and cavity filling and void fillings to the improvement of soils in earthworks. About three quarters of the produced quantities of hard coal fly ash is certified according to EN 450-1 "Fly ash in concrete" or has environmental approval by the building authorities and is used as concrete additives Type II in accordance with EN 206-1 and respective national application documents. The remaining quarter is used in mining, earthworks, road construction and for other purposes.

The raw material basis of hard coal fly ash is hard coal. Hard coal fly ash is produced in large combustion plants of power stations. Hard coal ground to a fine dust is blown into the boiler and burned at temperatures of more than 1.200° C. In the process, the non-combustible mineral dust particles, which are contained in the hard coal as a natural accompanying rock, are predominantly or completely melting. The fine mineral particles are transported in the flue gas stream and separated as hard coal fly ash for further use as a building material with electrostatic precipitators.

## Properties

Hard coal fly ash is a fine mineral dust. As a result of the high combustion temperatures, hard coal fly ash consists mainly of spherical glassy particles. The chemical composition is generally in the ranges given in Table 2-9. Hard coal fly ash consists mainly of silicon, aluminium, and iron oxides, the main constituents of the earth's crust. In addition, it contains various trace elements, just like natural rocks. Hard coal fly ash can also contain small amounts of residual coke. Due to the glassy-amorphous portions and the large active surface, hard coal fly ash reacts pozzolanic in the presence of lime and water and forms calcium silicate and calcium aluminate hydrates.

Table 2-9 General chemical composition of hard coal fly ash

Oxide	SiO <sub>2</sub>	Al <sub>2</sub> O <sub>3</sub>	Fe <sub>2</sub> O <sub>3</sub>	CaO	MgO	K <sub>2</sub> O	Na <sub>2</sub> O	TiO <sub>2</sub>	SO <sub>3</sub>
content in mass-%	40 – 55	23 – 35	4 – 17	1 – 8	0.8 – 4.8	1.5 – 5.5	0.1 – 3.5	0.5 – 1.3	0.1 – 2.0

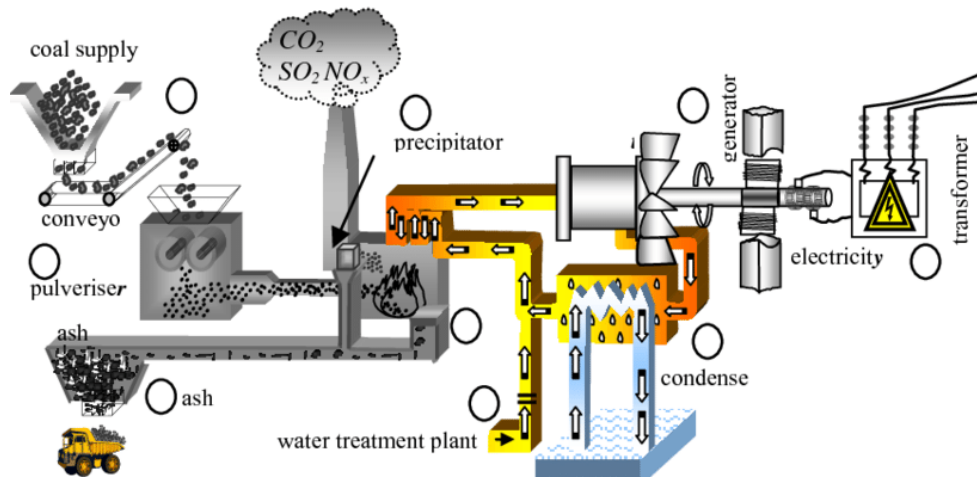

Figure 2-26 Production process in power plants [77]

### 2.4.1.3 Mining waste aggregates, discussed by means of waste rock separated from kaolin

A few companies are already producing aggregate materials from by-products, among which associated to the wastes of mining processes. One of these companies is Imerys, a leading supplier of industrial minerals such as calcium carbonate, clay, talc, mica, and diatomaceous earth. They have been providing kaolin or China clay waste to aggregate partners in the UK for many years [53]. These partners clean, crush and grade the materials for sale as secondary sands and crushed granite for construction. The by-products meet all the required norms and are also valued for their high-quality finish, having initially been processed in separating raw kaolin from the granite ore body from which it is extracted.

Imerys is now looking to map and evaluate a few of its other wastes and by-products for use in construction from their many quarries, sand tips and waste piles that have accumulated over time. One of the more challenging aspects of doing so is that the historical tips have been landscaped and rewilded over time, and often provide a vibrant ecosystem in their own right [78]. There is thus a delicate balance between the need to re-extract materials from the “landscape” and the production of primary raw materials. One solution is to ensure that all waste products, as they are produced, are supplied immediately for use as a feedstock for another industry, such as construction minerals.



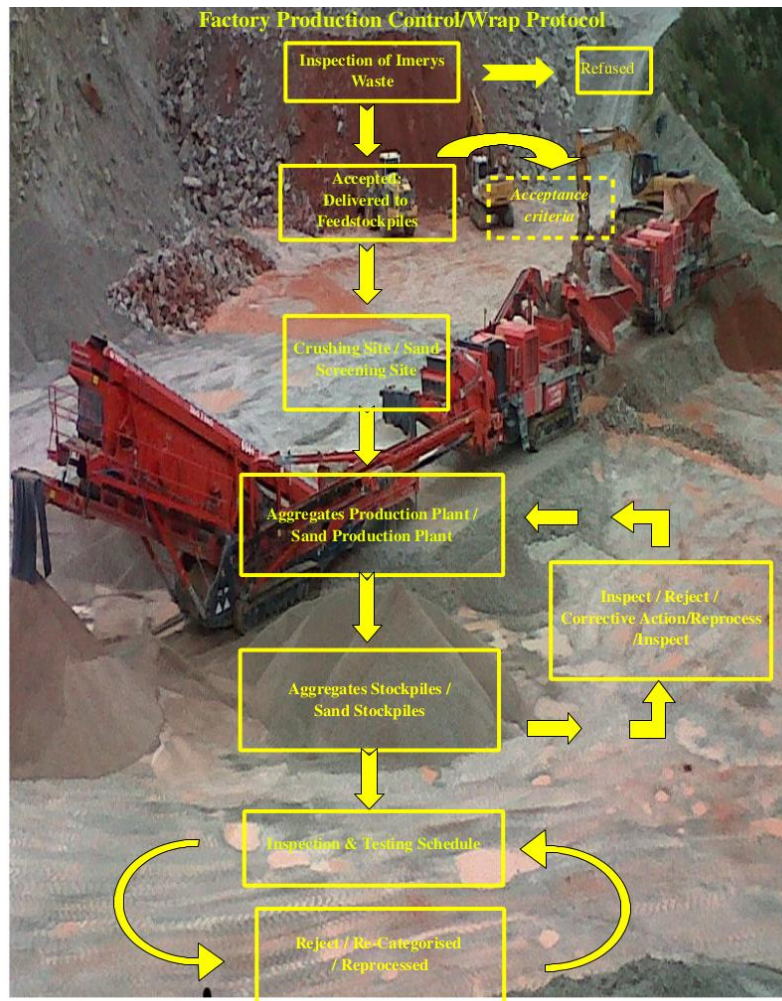

Figure 2-27 Production flow aggregates from kaolin waste  
(courtesy of Brookland Sand and Aggregates Ltd. UK)

#### 2.4.2 Biomass waste and by-products

Agricultural farming as one of the biggest industries all over the world has been providing food for the people. The largest production in this field is assigned to China, India, USA, Brazil, and Nigeria. Various types of farming waste materials, including palm oil, coconut, sugarcane, paddy, bamboo, olive, banana, corn, date palm and wheat were investigated to be used in concrete. Bamboo due to its proper mechanical properties, flexibility and low cost has become favourable among researchers, also given its availability by 20 million tons production rate per year [64]. Its leaf ash consisting of more than 80% SiO<sub>2</sub> can be calcined at 600°C for 2 hours to get a totally amorphous structure [64][79][80]. Another waste from the bamboo sector which can be used in concrete is bamboo fibres that can improve the tensile strength of the concrete up to 20% [81]. Apart from the bamboo leaf ash, wheat straw ash can be also used as supplementary cementitious material which could be made from the wheat straw of which 550 million tons is produced annually [80]. Barley straw ash is a similar waste material which can be replaced with binders. Other than that, barely straw fibres used in some researches showed the tensile strength up to 115 MPa [64][82]. The most produced cereal worldwide is corn which its cob is a waste agricultural product and rich in silicate. Burning it at 700°C will result in reactive amorphous silica that can be also practiced in concrete [83]. Olive waste ash, which generally includes 11% - 25% silica, can be also used as a SCMs. Banana leaf ash is another silica rich material that can be used as SCMs. In 2012, almost 10 million ton of banana leaf ash residues were

produced that shows a considerable resource. Burning it for 24 hours at 900°C provides approximately 49% amorphous silica content that makes it suitable for concrete industries.

Similarly, other agricultural waste resources such as sisal, date palm, elephant grass and aquaculture-farming waste, e.g., oyster, periwinkle, mussel and so forth, can be used as SCMs or fibres in concrete industry.

Further to agriculture waste, biomass ashes that can be considered as construction mineral are also generated in heat or energy plants based on wood waste that cannot be recycled locally. The processes generating this biomass ash are similar to that discussed in [Section 2.4.1.2](#).

## 3 ALKALI-ACTIVATED PRECURSORS AS BINDER FOR ECO-FRIENDLY CONCRETE

### 3.1 Introduction

The concept of alkali-activated binders that allow for reduced carbon footprint and less usage of primary raw materials, has been introduced in [Section 2.2.3](#). By means of this binder, so-called alkali-activated concrete can be made, that has comparable mineral composition, workability, strength and durability properties as Portland cement-based concrete. This alkali-activated concrete has been the focus of both EU projects URBCON and DuRSAAM.

The binder components of alkali-activated concrete are at one hand the ‘precursors’ for alkali-activation and at the other hand the ‘activators’ used to activate the precursors. As precursors by-products in the form of mineral powders, such as metallurgical slags, combustion ashes and calcined clays are used. Precursors are a class of materials that significantly overlap with supplementary cementitious materials (SCMs) for Portland clinker-based cements (see [Section 2.2](#)). As activator aqueous alkali solutions are used, such as for example a combination of sodium hydroxide and sodium silicate.

In the following a further discussion is given on these precursors and activators, as well as the chemistry of alkali-activated binders.

### 3.2 Chemistry of alkali-activated binders

The obtainment of alkali-activated materials (AAMs) is achieved by the chemical reaction involving aluminosilicate materials with intermediate-to-low-calcium content (precursors) and an alkaline liquid solution (activator). This reaction results in a hardened cementitious matrix which is physically similar to hydrated Portland cement (PC) but presents differences in its microstructure and chemical composition [\[5\]\[6\]\[84\]](#). The term “intermediate-to-low-calcium” is used to differentiate the precursors of this technology from minerals present in clinker: while the former presents a maximum Ca/Si ratio in the range of 1.5, the latter accounts for minerals in which CaO is by far the most representative portion, with Ca/Si ratio in the range of 1.5-3.0 [\[84\]\[85\]](#). This class of alternative binders is usually obtained by implementation of by-products of primary industrial processes as precursors, and the two most common examples are blast furnace slags (or simply slag) and coal fired fly ash (or simply fly ash).

The microstructure of a hardened AAM consists of a combination of unreacted binder particles, pores and new phases formed during alkali-activation. Differences in reaction products are caused by the chosen mix design, accounting for precursor and activator of preference. For all precursors, the main phase formed consists of amorphous-like gels similar to calcium silicate hydrates (C-S-H) commonly found in Portland cement hydration reactions accounting for substitution of Al in Si tetrahedral sites [\[6\]\[5\]](#). In such short-range ordered gels, Al substitution in Si-tetrahedral sites creates a negative

charge when it is present in tetrahedral coordination, which requires the adsorption of positive charges to maintain charge balance. In that sense, cations of alkali-earth elements present in the activator solution such as Na<sup>+</sup> or K<sup>+</sup> act as stabilizing agents for the gels [84]. The level of Ca supplied by the precursor will determine the main characteristic of the gel to be formed, acting as anchor for nucleation of CaO sheets surrounding silicate chains (C-A-S-H gel) [6][85]. For example, systems containing metallurgical slags or calcareous fly ash, or as charge balance in N/K-A-S-H gel, as for systems containing coal fired fly ash, metakaolin, and other biomass ashes [86][87]. Alongside the main products, intermediate gels C-N-A-S-H and N-C-A-S-H can be formed accordingly to the chemistry of the mix design [88][89].

C-A-S-H-type gel displays lower Ca content (showing usually a Ca/Si ratio approximate to 1.0) and higher Al content (with Al/Si ratio in the range of 0.1-0.2) than PC-formed C-S-H [90]–[93]. The C-A-S-H gel is mentioned in the literature as a low order version of tobermorite, which is one of the crystalline analogous structures of C-S-H – it is common sense to define the structure of C-S-H as being a poorly ordered jennite-like or 1.4 nm tobermorite-like phase, with alternate layers of CaO and finite silicate chains [91][92].

Literature states that C(N)-A-S-H is never sole on alkali-activated slags and is always linked to secondary phases afore mentioned [91][94]. The bulk composition of such precipitates is usually out of the chemical composition stability domain range of the pure gel. The two main secondary products are a Mg, Al-rich lamellar structure and AFm-like phases [91][95].

The Mg-Al layered double hydroxide (LDH) is the main secondary phase formed during the hardening of BFS based cementitious systems and accounts for most Mg atoms supplied by the precursor. However, it is only observed with a MgO content above 5% [91][96]. Authors have also exposed that varying levels of MgO will not show effect on the chemical composition of C-(N)-A-S-H, thus proving its functionality only as LDH forming agent [88][97].

The second most important secondary precipitates are AFm-like phases, in which the structure is similar to a layered double hydroxide, but the main layer is based on portlandite rather than brucite. In this case, Ca<sup>2+</sup> can be substituted by either Al<sup>3+</sup> or Fe<sup>3+</sup>, with anions providing charge-balancing conditions on the second layer [97].

N-A-S-H gel can be considered a zeolite-precursor product, presenting similar chemical composition to this class of minerals and structural arrangement of shorter order, as reported for X-ray pair distribution functions [98][99]. The type of zeolite to be formed is highly dependent on parameters of the reaction, such as H<sub>2</sub>O/SiO<sub>2</sub> and OH<sup>-</sup>/SiO<sub>2</sub> ratios, number of cations, Si/Al ratio, and SiO<sub>2</sub>/Na<sub>2</sub>O ratio [100].

Changes in the N-A-S-H gel are attributed to the nature of fly ash and activating solution, which can lead to gels with different Si/Al and Na/Al ratios [101]. Higher initial Si/Al ratios in the system lead to the formation of more cohesive hardened matrix, resulting in a more refined microstructure with lower porosity [6]. The differences in the chemical composition of the raw materials used, not only lead to microstructural diversities but also to different mechanical and physical properties. Fly ash alkali-activated materials, for example, are more durable and stronger [6].

### **Characterization of reaction products**

The chemical composition and the degree of crosslinking of (calcium) aluminosilicate gels can have variations according to experimental conditions and chemical composition of precursor. Garcia-Lodeiro et al. studied the compatibility of N-A-S-H and defined the composition range of the intermediate N-(C)-A-S-H product to be  $0 < \text{Na/Al} < 1.85$ ,  $0 < \text{Ca/Si} < 0.3$ ,  $0.10 < \text{Si/Al} < 0.8$ , while indicating that Ca/Si ratios higher than 0.72 will result in formation of separate C-A-S-H and N-A-S-H phases [102]. Zhao et al. defined the threshold value of the  $(\text{Na} + \text{K} + \text{Ca})/\text{Al}$  to be 0.95 with a Ca/Na

ratio of 0.73 (degree of substitution of Ca<sup>2+</sup> for Na<sup>+</sup> equal to 15%), which above leads to the co-existence of N-A-S-H and C-A-S-H and below leads to the formation of N-(C-)A-S-H gels [103]. Puligilla et al. reported the formation of separate K-A-S-H and C-S-H/C-A-S-H phases with a Ca/Si and Al/Si ratios of 0.45 and 0.36, respectively, and formation of mixed K-(C-)A-S-H gel with Ca/Si and Al/Si ratios of 0.13 and 0.44, respectively, for alkali-activation of siliceous fly ash with addition of C-S-H seeds in different alkaline environments [104].

As for the N-A-S-H gel, implementation of water glass solutions generates higher Si/Al ratio, Bakharev et al. found an Si/Al ratio in the range of 1 – 2.5 for fly ash activated with a 8 wt% Na<sub>2</sub>O solution [105], while Winnefeld et al. reported an average Si/Al ratio ranging from 3.4 to 4.6 (with variable Na<sub>2</sub>O wt% from 5.2 to 6.3 and fixed Ms = 2) [106]. Fernández-Jiménez et al. reported a Si/Al ratio from 1.62 to 2.17 and from 2.24 to 3.35 for fly ash activated with sole NaOH (8.68wt% Na<sub>2</sub>O) and combined with water glass (7.74 wt% Na<sub>2</sub>O; 9.52 wt% SiO<sub>2</sub>) [101].

The conclusion one can reach is that the formation of different nano-structured N-A-S-H and N-(C-)A-S-H gels will occur simultaneously and in an intimate form throughout the microstructure of hardened binders. Tuinukuafe et al. used atom probe tomography to investigate the distribution of elements in dense regions of hardened pastes activated with a mix of potassium hydroxide and potassium silicate. Although results display an average Si/Al ratio equal to 4.75, the 3D reconstruction images indicate a widely heterogeneous distribution of elements, with Si present in larger extent throughout the whole analysed region, while Al is observed to be abundant in regions either coupled with high Si content or circulated by high Si [107].

The main secondary reaction product in AAM systems, zeolites, are a group of crystalline materials with similar chemical composition to N/K-A-S-H gels but with a highly connected network of silica and alumina tetrahedra linked by shared oxygen atoms, displaying a channelized structure with high surface area [108][109]. Due to their similarity, N/K-A-S-H gels are considered nano-structured zeolite species which will not display a full crystallization behaviour due to insufficient curing conditions [100]. The type of zeolite to be nucleated is highly dependent on parameters of the reaction, such as H<sub>2</sub>O/SiO<sub>2</sub> and OH-/SiO<sub>2</sub> ratios, number of cations, Si/Al ratio, and SiO<sub>2</sub>/Na<sub>2</sub>O ratio [100]. Formation of a wide range of zeolite types has been reported in the literature, and the catalogue of such phases is vital for a proper understanding of nucleation mechanisms of AAMs and their performance during application. Table 3-1 provides a summary of the main phases reported in literature and their method of identification.

*Table 3-1 Summary of Zeolite phases*

Zeolite type	Chemical composition	Activator	Curing	Identification method
Zeolite Y (Faujasite-Y)		NaOH + WG (Ms = 0.5; 8wt% Na <sub>2</sub> O) [110] NaOH + WG (Ms = 0.69; 7.84wt% Na <sub>2</sub> O) [100]	20°C for 24h + 55°C for 6 days [110] 85°C for 180 days [100]	-XRD (peaks at 8°,) [110] - FTIR (spectrum at 712 cm <sup>-1</sup> and 574-502) [100][111]
Heulandite	(K, Na)Ca <sub>4</sub> Al <sub>9</sub> Si <sub>27</sub> O <sub>72</sub> .24H <sub>2</sub> O [111]	Ca (OH) <sub>2</sub> (25wt% CaO) [110]	20°C for 24h + 55°C for 6 days [110]	- XRD (peaks approx. at 25 and 30°) [110] - FTIR (vibration spectra at 777-715) [111]



Hydroxodalite	$\text{Na}_4\text{Al}_3\text{Si}_3\text{O}_{12}\text{OH}\cdot 1\text{H}_2\text{O}$ [101]	- NaOH (8.68% of $\text{Na}_2\text{O}$ ) and $\text{Na}_2\text{CO}_3$ (8.68% $\text{Na}_2\text{O}$ ; 6% $\text{CO}_3^{2-}$ ) [101]; - NaOH + WG (NaOH 5M; $M_s = 0.88$ ) [112]	- 85°C for 20h [101] 100° for 24h; 25°C for 27 days [112] 25°C for 2h; 75°C for 1 month [105]	- XRD (peaks at approx. 13, 24, 35, 42°) [101][112] - FTIR (vibration spectra at 650-720) [113][105]
Herschelite/ Chabazite-Na	$\text{NaAlSi}_2\text{O}_6\cdot 3\text{H}_2\text{O}$ [101]	NaOH (8.68wt% $\text{Na}_2\text{O}$ ); NaOH + WG ( $M_s = 1.23$ ; 7.74wt% $\text{Na}_2\text{O}$ ) [101] NaOH (9.3wt% $\text{Na}_2\text{O}$ ) [114] NaOH + $\text{Na}_2\text{Al}_2\text{O}_4$ (1.52wt% NaOH; 31.40wt% $\text{Na}_2\text{Al}_2\text{O}_4$ ) [115]	85°C for 20h [100][101]; 60°C for 28 days [34]; 70°C for 24h [115]	- XRD (peaks at approx. 12, 24, 30, 34, 42°) [101][114][115] - FTIR (vibration spectra at 635, 520-460) [100][116] - <sup>29</sup> Si MAS NMR (chem. shifts on -88.6, -93.2, -98.5, -104.2, -109.7) [117]
Trona	$\text{Na}_2\text{H}[\text{CO}_3]_2\cdot 2\text{H}_2\text{O}$ [101]	$\text{Na}_2\text{CO}_3$ (8.68wt% $\text{Na}_2\text{O}$ ; 6wt% $\text{CO}_3^{2-}$ ) [101]	85°C for 20h; [101]	- XRD (peaks at approx. 17, 27 and 32°) [101] - FTIR (vibration spectra at 851 $\text{cm}^{-1}$ ) [101]
Nahcolite	$\text{Na}_2\text{HCO}_3$ [101]	$\text{Na}_2\text{CO}_3$ (8.68wt% $\text{Na}_2\text{O}$ ; 6wt% $\text{CO}_3^{2-}$ ) [101]	85°C for 20h; [101]	- XRD (peaks at approx. 28 and 33°) [101] - FTIR (vibration spectra at 841 $\text{cm}^{-1}$ ) [101]
Zeolite P/Gismondie	$\text{Na}_6\text{Al}_6\text{Si}_{10}\text{O}_{32}$ [118]	WG ( $M_s = 1$ ; 6.1wt% $\text{Na}_2\text{O}$ ; 5.9wt% $\text{SiO}_2$ ) [118] NaOH (8wt% $\text{Na}_2\text{O}$ ) [105] NaOH + WG ( $M_s = 0.69$ ; 7.84wt% $\text{Na}_2\text{O}$ ) [119][100] NaOH + WG (NaOH 5M; $M_s = 0.88$ ) [112]	30°C for 180 days; [118] 95°C for 140 days; [105] 85°C for 180 days [119][100] 25°C for 27 days [112]	- XRD (peaks at approx. 13, 18, 28, 33 and 34°C) [118][105] [119][112] - FTIR (vibration spectra at 712 and 620 $\text{cm}^{-1}$ ) [100][111]
Cancrinite	$\text{Na}_8(\text{Si}_6\text{Al}_6\text{O}_{24})(\text{H}_{0.88}(\text{CO}_3)_{1.44})\cdot 2\text{H}_2\text{O}$ [120]	WG ( $M_s = 1.5$ ; 4.8wt% $\text{Na}_2\text{O}$ ; 7.0wt% $\text{SiO}_2$ ) [120] NaOH (12.4wt% $\text{Na}_2\text{O}$ ) [121] NaOH + WG ( $M_s = 0.69$ ; 7.84wt% $\text{Na}_2\text{O}$ ) [119]	60°C for 24h and 25°C for 365 days; [120] 80°C for 6h; [121] 85°C for 180 days; [119]	- XRD (peaks at approx. 24, 34, 39 and 49) [120][121][119] - FTIR (vibration spectra at 876, 684 and 622 $\text{cm}^{-1}$ ) [120][111]
Franzinite	$(\text{Na}, \text{Ca})_7(\text{Si}, \text{Al})_{12}\text{O}_{24}(\text{SO}_4, \text{OH}, \text{CO}_3)\cdot 3\text{H}_2\text{O}$ [120]	WG ( $M_s = 1.5$ ; 4.8wt% $\text{Na}_2\text{O}$ ; 7.0wt% $\text{SiO}_2$ ) [120]; WG ( $M_s = 3.22$ ; 3.2wt% $\text{Na}_2\text{O}$ ; 10.6wt% $\text{SiO}_2$ ) [121]	60°C for 24h and 25°C for 365 days; [120] 80°C for 6h; [121]	- XRD (peaks at approx. 18, and 24°); [120]



Levyne	$\text{NaCa}_{2.5}(\text{Al}_6\text{Si}_{12}\text{O}_{36}) \cdot 18\text{H}_2\text{O}$ [111]	WG (Ms = 1.5; 4.8wt% $\text{Na}_2\text{O}$ ; 7.0wt% $\text{SiO}_2$ ) [120]; WG (Ms = 3.22; 3.2wt% $\text{Na}_2\text{O}$ ; 10.6wt% $\text{SiO}_2$ ) [121]	60°C for 24h and 25°C for 365 days; [120] 80°C for 6h; [121]	- XRD peaks (peaks at approx. 9, 17, 28°) [120] - FTIR (vibration spectra at 766-711, 639, 516 $\text{cm}^{-1}$ ) [111]
Natrolite	$\text{Na}_2\text{Al}_2\text{Si}_3\text{O}_8 \cdot 2\text{H}_2\text{O}$ [108]	NaOH + WG (Ms = 2.09; 10.2wt% $\text{Na}_2\text{O}$ ; 21.4wt% $\text{SiO}_2$ ) [122]	85°C for 28 days [122]	- FTIR (vibration spectra at 718, 678, 628, 511, 418 $\text{cm}^{-1}$ ) [111]

### 3.3 Precursors for alkali-activation

In the URBCON and DuRSAAM projects focus has been given both to more traditional by-products that are well established for SCMs (for blended Portland cement-based concrete) and precursors (for alkali-activated concrete), as well as alternative precursors in view of more traditional precursors that might become less available and in view of wider circularity opportunities (and associated industrial symbiosis).

#### 3.3.1 Traditional precursors

##### 3.3.1.1 Alkali-activated materials

The obtainment of alkali-activated materials (AAMs) is achieved by the chemical reaction involving aluminosilicate materials with intermediate-to-low-calcium content (precursors) and an alkaline liquid solution (activator). This reaction results in a hardened cementitious matrix which is physically similar to hydrated Portland cement (PC) but presents differences in its microstructure and chemical composition [5][6][123]. The term ‘intermediate-to-low-calcium’ is used to differentiate the precursors of this technology from minerals present in clinker: while the former presents a maximum Ca/Si ratio in the range of 1.5, the latter accounts for minerals in which CaO is by far the most representative portion, with Ca/Si ratio in the range of 1.5-3.0 [6][85]. This class of alternative binders are usually obtained by implementation of by-products of primary industrial processes as precursors, and the two most common examples are blast furnace slags (or simply slag), and coal fired fly ash (or simply fly ash).

##### 3.3.1.2 Types and chemistry of precursors

Fly ash is obtained as a valuable waste from thermo-electrical power plants. When pulverized coal is inserted into furnaces for combustion and further energy generation, the non-combustible inorganic compounds melt and fuse in the form of droplets. These droplets are captured by exhaustion and separated from flue gases using electrostatic or mechanical precipitators, being cooled down to form spherical glassy particles [124]. There are two main classes of coal available for energy obtainment: anthracite and bituminous coals are older and found in deeper layers of the soil, rich in carbon and silicon dioxide and being the optimum choice for power plants; while sub-bituminous coals are found in shallower layers and contain lower levels of carbon [124][125]. These two types of coal present a well-defined division of the generated fly ash according to ASTM C-618. Siliceous fly ashes, or class F fly ashes, contain low levels of calcium and a summed quantity of  $\text{SiO}_2$ ,  $\text{Al}_2\text{O}_3$  and  $\text{Fe}_2\text{O}_3$  higher than 70%; while calcareous fly ashes, or class C fly ashes, present high levels of calcium and a summed quantity of the other three main oxides in between 70% and 50% [124][126].

Blast furnace slag is formed by the thermo-chemical reduction of iron ore inside blast furnaces for production of pig iron, the first component for steel manufacturing. The contaminants of the iron ore

react with coke and the hot air inside the furnace to form a phase called “slag”, which is separated from the molten iron. These phases can be separated in the skimmer and further processed for its future applications [127][128]. At the end of the melting process, the temperature of the slag is approximately 1500°C, and the cooling method is essential to determine its properties and reactivity. Water-cooling is used to enhance the heat exchange, resulting in a larger quantity of amorphous material at the end of the process. The cooled slag is then grounded into a fine powder and is ready to be used as a precursor or SCM. Typical composition of these slags, compared to class F and C fly ashes is illustrated in Figure 3-1.

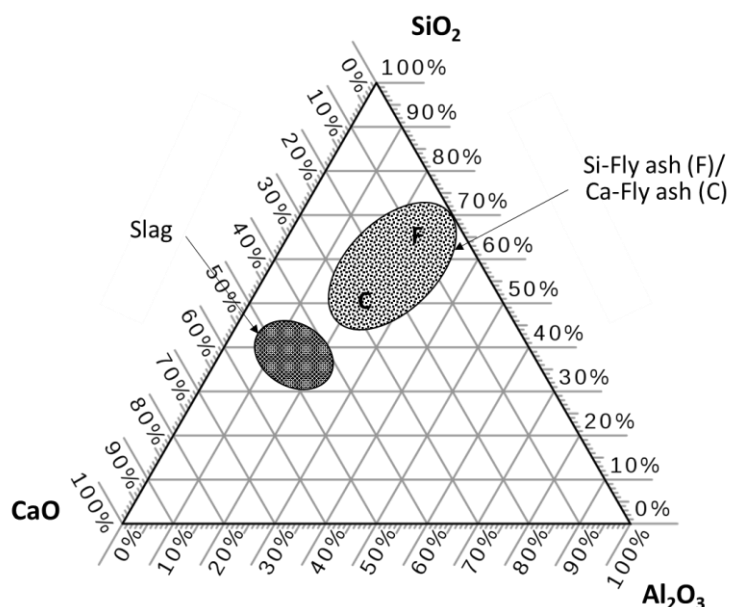

Figure 3-1 Chemical compositions of different fly ashes and blast furnace slags reported in the literature, accounting for the main reactive oxides (adapted from [42])

A third class of precursor is natural clays that are calcined and which are aluminosilicates with pozzolanic properties [152][157]. After calcination, clays can be successfully used as precursors in alkali activation, even though their full potential as cement-replacements has not yet exploited. The process of calcination of clays take place between 500 and 800°C and the result is a disordered, partially amorphous product derived by the dehydroxylation of the clay, Kaolin, illite and montmorillonite are the three natural clays of major abundance on earth crust, and between them kaolin was demonstrated to give the best pozzolanic reactivity [149][154]. Kaolin can be extracted as a pure mineral, or it can derive from waste sources as mine-tailings or paper industry wastes. Alkali-activation offers a pathway for valorisation of less-pure clays.

Between all calcined natural clays, metakaolin is the most used. Metakaolin is a partially amorphous transition phase with high reactivity, derived from the thermal activation of kaolin between 600–800°C, just below the temperature of recrystallization to mullite (900°C). Kaolin loses its layered and ordered structure and the new reactivity is associated with the geometric strain of the aluminium sites and the high energy of Al-O-Al bonds [193]. It is a popular precursor for alkali-activation due to the high purity, a consistent composition, and high reactivity. The particle shape and fineness are the main limitation to a wider usage of metakaolin in applications [179]. The plate-like particle morphology along with high specific surface area and high electrostatic charge density of particles cause workability and dispersion issues and a high-water demand.

The replacement of traditional rotary kiln calcined metakaolin with flash calcination has shown to improve the physical properties and performance of the raw material: flash-calcined metakaolin contains spherical particles and the water demand is reduced while mixing [174][175][185].

Even though, it was demonstrated that solely metakaolin-based concretes can reach satisfactory properties, the most beneficial way of utilization of metakaolin is in blended binders (with GGBFS or fly ash) and for specific applications [173][187].

The reactivity of precursors can be directly linked to the initial content of CaO, especially in mild conditions of pH and temperature. Since Ca is not a natural network forming element (NWF), its presence is responsible for interrupting a consolidated glass network as it creates localized disturbances. The presence of Ca acting as a network modifier element (NWM) promotes a less connected framework, leaving behind a loose and more reactive structure. Therefore, precursors can be categorized in two classes: calcium-rich or silicon rich. Calcium-rich precursors (such as slag and fly-ash class C in Figure 3-1) exemplified by metallurgical slags (such as blast furnace slag, ladle furnace slag or basic oxygen furnace slag) or calcareous fly ashes, present a chemical composition with  $(\text{SiO}_2 + \text{CaO}) > 70\text{wt}\%$  [89][129][130], usually displaying a higher degree of amorphous material and can be activated under moderate alkaline conditions, leading to the formation of variations of calcium aluminosilicate hydrate gels, or C-A-S-H (with variations being C-N/K-A-S-H, C-N/K-S-H, C-S-H), depending on the content of secondary oxides [91]. Silicon-rich precursors (such as fly-ash class F in Figure 3-1) are comprised of Al- and Si-rich materials, such as siliceous fly and bottom ashes (coal fired fly ash, municipal solid waste incineration bottom ash, rice husk ash, biomass ashes), metakaolin, recycled glass, silica fume, and others, requiring more aggressive conditions to initiate the activation process (high alkalinity and curing temperatures of above ambient), resulting in the formation of aluminosilicate hydrates (N/K-A-S-H) gels – also named as geopolymer in the literature [131][132].

### 3.3.1.3 Availability of precursors

The practical implementation of fly ash and blast furnace slag as main constituents of alkali-activated binders is dependent on the existence of their primary industrial processes. In this context, availability of these two precursors is strongly linked to the geographical availability of raw materials for these two industries.

Coal is source for nearly 35% of total global electricity in 2020 [133][134]. Approximately 85% of global coal reserves are available in North America, Oceania, CIS countries and Asia, with the latter being responsible for approximately 65% of total global coal consumption [133]. However, coal-based energy is strongly linked to high levels of CO<sub>2</sub> emissions, and the world is expected to gradually reduce and replace this type of energy by renewable sources. As shown in Figure 3-2 the profile of coal consumption, directly linked to availability of fly ash, has changed over time. While Asia has increased its global participation in consumption from 65% to 78% (100.1 exaJoules to 119.2 exaJoules), both Europe and North America, the two largest consumers of coal after Asia, have significantly decreased the coal consumption for generation of energy from 15.3 and 22.4 exaJoules (2010) to 9.4 and 9.9 exaJoules (2020), respectively. Coal-based energy production is on the verge of reaching its peak, with current estimates indicating that it will account for only 22% of global energy generation by 2040 [135]. The availability of fly ash in regions such as Europe has therefore been decreasing over the years and importing fly ash to be used in low-carbon concrete solutions is object to careful life cycle analysis considerations as transport generally can a large impact on the overall carbon footprint of concrete products.

The availability of blast furnace slag is directly related to production levels of pig iron, as approximately 300 kg of slag are generated for each 1 ton of pig iron produced in blast furnaces [127]. However, global production of pig iron displays a decelerated growth rate, with total production in the range of 1.3 billion tons in 2019 and 2020 [136][137] – with China being responsible for over 60% of total amount. Production levels are expected to grow at low rates for the next 10 years, reaching 1.5 billion tons only in 2030 [138].

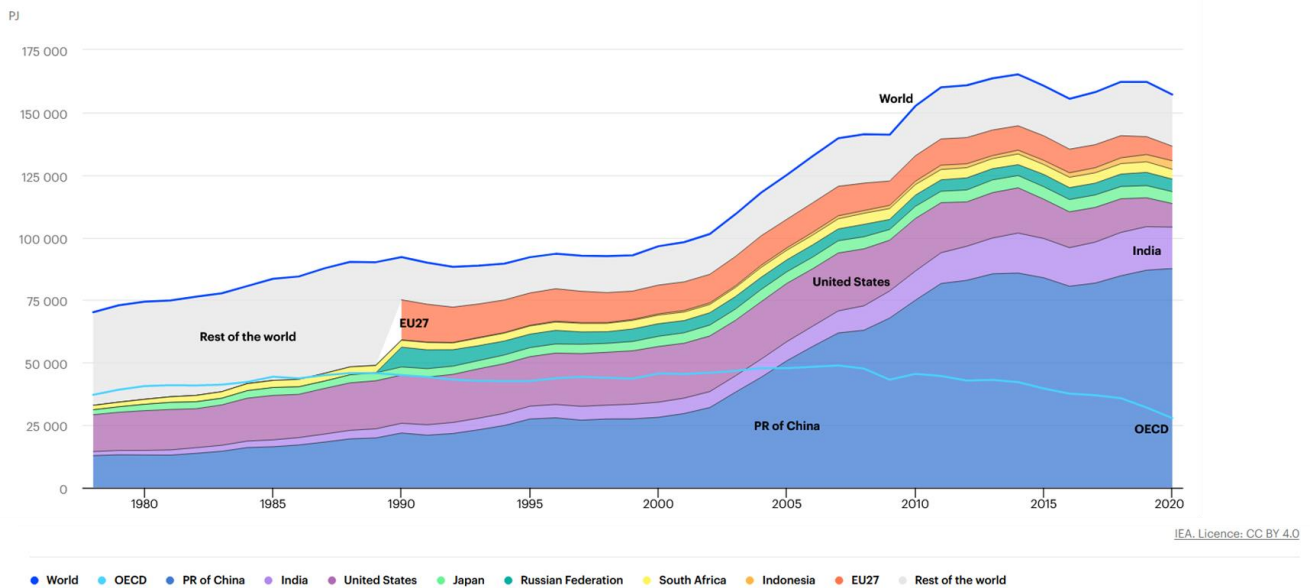

Figure 3-2 Profile of global coal consumption over time (<https://www.iea.org/data-and-statistics/charts/world-coal-consumption-1978-2020>)

The future availability of both fly ash and slag do not follow the forecast of demand of cement, as detailed in Table 3-2. In 2018, approximately 4.1 billion tons of cement were produced, and while this demand is expected to grow 17% until 2025, reaching a total of 4.8 billion tons [139], the availability of the two main precursors of AAMs is expected to either grow in low rates or even decrease – 20% for blast furnace slag and – 7% for fly ash. Thus, a suppressed global distribution of raw materials for alkali-activated precursors can be expected, with the emergence of clusters of available materials in a few regions of the planet. This can lead to increased importation levels in regions with high cement demand, and possibly a rise in prices of raw materials, worsening the balance of geographical availability of such materials and the embodied CO<sub>2</sub> emissions on such mixes.

Kaolin is a commercial product of high purity with geographical limitation. Conversely, natural clays are one of the most abundant and widely available aluminosilicate sources on earth. The potential of alkali activation is also related to the possibility of valorizing a waste or low-purity material, therefore the focus should be on including local available clays as precursors.

Table 3-2 Reported data on production of precursors of AAMs vs Portland cement and their expected future demand [133][136] – values in million tons

	Blast furnace slag	Fly ash	Portland cement
Amount produced in 2010	310	700	3,300
Amount produced in 2018	375	1,080	4,100
Variation – 2010-2018	21%	54%	24%
Estimated production in 2025	420	1,000	4,800
Variation– 2018-2025	12%	-7%	17%

### 3.3.2 Alternative precursors for alkali-activation (from waste sources)

There is an emerging drive to reduce the environmental impact of construction industry at a foundation level [19][169]. The exploration of novel waste materials and incorporation of recycling pathways utilising alkali activation has become a key technology in allowing valorization of large

quantities of wastes from diverse streams. There exists a large variety of waste materials which are either pozzolanic or have intrinsic binding properties (latent hydraulic) which can be used to produce binders [177]. The traditional waste precursors, intensively used in alkali-activation research and in current early-stage commercialisation. GGBFS and coal fly ash are decreasing in availability due to limited geographical availability but especially to their competitive market as supplementary cementitious materials in conventional cement manufacture [166]. Therefore, the focus of research should move towards new waste sources to be used in alkali-activation, considering the local availability to maximise the environmental benefit. Major factors to consider when evaluating the viability of new waste sources is the annual volume output and long-term stability of production, along with geographical considerations [143]. These factors are fundamental in allowing alkali-activated technology to become a competitive alternative to conventional cement manufacture.

Other precursors, not currently under mainstream investigation are classes of non-BF steel slags and non-ferrous slag precursors [144][147][176][186].

#### 3.3.2.1 Steel slags

The extraction of pig iron from the ores is followed by the process of conversion to steel. Depending on the process used, different types of slags are generated, such as basic oxygen furnace (BOF) slags, electric arc furnace (EAF) slags, ladle slags and converter slags, all characterised by highly variable chemical compositions and considered hazardous wastes in some administrations.

#### 3.3.2.2 Phosphorous slags

Elemental phosphorous can be extracted from the phosphate ore, generating a calcium silicate rich slag which have been studied in alkali activation for decades [145].

#### 3.3.2.3 Metallurgical non-ferrous slags

Silicate-rich slags are also obtained from the pyrometallurgic industry which extracts metals such as Cu, Ni, Zn and Pb from the respective ores. The volumes of production are quite large, and the composition is usually suitable to be used in alkali-activation. However, most of the studies are restricted to a singular source of local slag due to large inconsistency and variability in composition. Examples of studies for specific slags are listed below:

- Copper slag [188]
- Nickel [194] ferronickel slags [161][168]
- Copper nickel slag [159]
- Silicomanganese slag [163][171]
- Manganese slag [189]
- Titaniferous slag [189]
- Zinc slag [140]
- Lead slag [172]

Additionally, several potential waste sources have been identified in literature [143][151] for future management and valorisation, as listed in the next sections.

#### 3.3.2.4 From urban wastes

Municipal solid waste (MSW) incineration ashes, ceramic waste and recycled glass are raw materials that can be easily found in all regions of the planet, with similar characteristics as the aforementioned. Alternatively, there has been a recent focus of researchers on the use of other ashes which are produced in a few parts of the world but require a specific process, as sewer sludge (SSA), wood construction biomass (BWA) and paper sludge ashes (PSA). This group of materials usually present a relatively high Ca content (oxides of a number of these ashes are illustrated in Figure 3-3)

and its application as partial replacement of blast furnace slag or fly ash has been positively assessed in the literature, specifically:

1. Ashes from municipal solid waste (MSW) incineration

MSWs can be divided in two major classes: bottom ash (BA-MSW) and fly ash (FA-MSW).

The major concern for these kinds of wastes, is the leachability of some of hazardous compounds such as organic chemicals, alkalis, and heavy metals (Zn, Co, Ni and Sn). Via alkali-activation it is possible to stabilise MSW ashes, reducing the leachability of hazardous compounds. Liu et al. 2021 [164]; Luna Galiano, Fernández Pereira, and Vale 2011 [167] increase mechanical properties by treatment with CaO [155][196] and increase the reactivity of FA-MSW by washing treatment prior alkali-activation [196].

2. Demolition and ceramic type wastes

This waste type can be divided into demolition-construction wastes, such as concrete, bricks, roof tiles and ceramic materials [195], and wastes produced by the ceramic industry including waste residuals from thermal processing and the manufacture of construction materials [182]. The latter wastes are usually easier to utilise in alkali activation, as the product compositions, and therefore wastes, in these industries are tightly controlled. Demolition-construction wastes on the other hand are generally variable in composition, however, suited as aggregate and/or filler materials [181] and in some cases in alkali-activation. [195]

3. Wastes or sediments from water treatment plants

The solid sewage sludge (SSA) generated by wastewater treatment can be used in construction as a filler material, as a fine aggregate or as mineral admixture [170]; and in some cases has been used as raw material for bricks [141]; [190] however, the pollution of the original source is a strictly limiting factor.

4. Waste glass

Most waste glasses are recycled and reused within the glass industry. However, certain glass colorants render a certain amount of glass production unsuitable for recycling. This fraction of undesired glass can be utilised as a rich source of amorphous reactive silica within the alkali-activation framework. These characteristics make waste glass suitable for use as solid precursors or as raw material to produce silicate-based activators. [142] [162] [184]

### 3.3.2.5 From agro industrial wastes

Biomasses ashes, such as rice husk (RHA), palm oil fuel (POFA), and sugar cane bagasse ashes (SCBA), are widely available in warmer climates and have been extensively studied in the past years as components in blended AAM mixes. These materials constitute a group of alternative precursors with the common characteristic of presenting low Ca contents (oxides of a number of these biomass ashes are illustrated in Figure 3-3).

1. Rice husk ash (RHA)

Rice is the third-highest produced crop worldwide, with every ton of rice processed producing about 0.2 tonnes of rice husk [148]. The amorphous silica content makes rice husk suitable for alkali-activation and like waste glasses, it has dual functionality as a blended precursor [150] or as raw material for the production of sodium silicate [191].



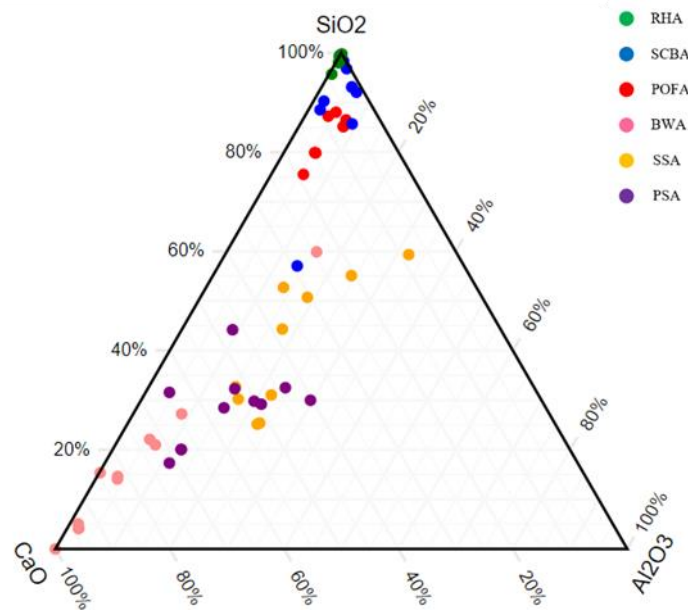

Figure 3-3 Distribution of the three main oxides in compositions of alternative precursors

## 2. Palm oil fuel ash (POFA)

The high silica content and fine particle grades of POFA, make this material highly reactive and desirable in blended alkali-activated materials, especially in developing high strength binders [156] [183]. Most studies to date focus on individual POFA sources, although combined research has confirmed more general conclusions confirming POFAs suitability as a world-wide waste source for alkali-activation.

## 3. Sugar cane bagasse ash (SCBA)

Sugar cane is the most produced crop globally [148] with every tonne of sugar cane processed producing 0.3 tons of wet bagasse, Suitability studies concerning the sole use of wet bagasse in alkali-activation are limited. However, blended SCBA systems have been shown to result in good performance binders [146].

### 3.3.2.6 From the mining and mineral industries

#### 1. Red mud

Red mud is a by-product in alumina extraction from bauxite through the Bayer process. For every ton of alumina, 1 to 1.5 ton of red mud is generated. Red mud is silica-rich, but aluminium is present only in residual amounts. To use red mud in alkali-activation, it is necessary to blend red mud with metakaolin or fly ash as additional sources of aluminium [153].

#### 2. Kaolin wastes

Kaolin is the clay mineral most used in the manufacture of paper, ceramics, and refractories, High purities are required and after the extraction from open-cut mines, kaolin goes through various purification treatments and adjustment. Rejected kaolin sludge, generated as a by-product of these purification treatments, can be subsequently calcined to form metakaolin. The calcined kaolin sludge is pozzolanic and reactive, making it suitable material for alkali-activation [165].

#### 3. Low purity clays

Non-kaolinitic clays, such as montmorillonites, smectites and illites are abundant and widely found around the world. Their abundance has the potential to provide long term stability as precursor

materials, and for future scale up of alkali-activated technology. However, their variable composition and mineralogical complexity is a major issue affecting their current usage. Further investigation into the usage of these clays is required, specifically as there is not a unified approach for alkali-activation across various mineral types [160].

### 3.4 Activators for binders

Alkaline activators is the second essential component in the design of alkali-activated materials and they also represent the main difference between alkali-activated materials and Portland cement-based materials which only require water for the hardening process.

The function of the activator is to introduce the driving force needed for the dissolution of the component (calcium silica and alumina) present within the precursor materials and to promote their polycondensation through the alkaline liquid media and subsequent hardening.

The alkali source is usually a liquid solution, with the most used alkali-activators including hydroxides and/or concentrated alkali metal silicates. It has been widely observed that activator properties strongly influence the final material performance and consequently define the materials potential applications (Table 3-3). The effectiveness of the activator is associated with the elevated pH and the reactive species that each of these solutions can provide. Ideally, any soluble substance which can supply alkali metal cations, increase the pH of the solution and accelerate the dissolution of the solid raw materials, can be used as an activator [5]. For some applications alkali metal sulphates [197] or carbonates [198]–[200] (generally  $\text{Na}_2\text{SO}_4$  and  $\text{Na}_2\text{CO}_3$ ) can be used. This allows an overall reduction of cost and increase in environmental benefit. However, they can cause a delay in hardening and in strength development [201].

*Table 3-3 Summary of raw materials and activator relationship (M is usually K or Na) [5]*

Precursor	MOH	$\text{M}_2\text{O}\cdot r\text{SiO}_2$	$\text{M}_2\text{CO}_3$	$\text{M}_2\text{SO}_4$
Blast furnace slag	acceptable	desirable	desirable	acceptable
Fly ash	desirable	desirable	poor	requires blending
Calcined clays	acceptable	desirable	poor	requires blending
Natural pozzolans	acceptable	desirable	-	-
Aluminosilicates	acceptable	acceptable	poor	poor
Synthetic glass	desirable	desirable	-	-
Steel slag	-	desirable	-	-
Phosphorus slag	-	desirable	-	-
Ferronickel slag	-	desirable	-	-
Copper slag	-	acceptable	-	-
Red mud	-	acceptable	-	-
Bottom ash	-	acceptable	-	-

Generally, the parameters used to formulate activator solutions based on sodium silicate and sodium hydroxide are:

- The dosage of activator in terms of  $\text{Na}_2\text{O}$  (wt. % $\text{Na}_2\text{O}$ ) is defined as the ratio of  $\text{Na}_2\text{O}$  content of alkaline activator with respect to the mass of precursor.
- The activator modulus ( $M_s$ ) which is the mass ratio of  $\text{SiO}_2$  to the  $\text{Na}_2\text{O}$  in alkaline activator.

Dosage and modulus both affect mechanical and rheological properties of alkali-activated binders and in blended activator solutions there is an optimum value for each of these parameters due to competing effects.

### 3.4.1 Alkali hydroxides

Sodium is the alkali metal most frequently used in the hydroxide solutions for alkali-activation, potassium hydroxide is also used in limited specialised applications [202]. Potassium hydroxides are reported to provide more rapid reaction times, less homogeneous gel microstructures, and higher one-day strengths. This is followed by a significant slowdown, giving a lower late age strength than comparable mixes activated with sodium silicates [203]. An additional drawback observed on the usage of potassium hydroxides is a greater vulnerability to carbonation compared to sodium hydroxide activated systems [204].

Sodium hydroxide is produced industrially through the chloralkali process, involving the electrolysis of sodium chloride in aqueous solution and the co-formation of hydrogen and chlorine. The energy involved in production and the CO<sub>2</sub> emissions must be accounted for when sodium hydroxide is used in alkali-activation.

The function of the hydroxide OH<sup>-</sup> ion is to induce the hydrolysis of Si-O-Si and Si-O-Al bonds producing readily available Si<sup>4+</sup> and Al<sup>3+</sup> cations in solution. The high pH also plays an important role in affecting the initial dissolution rate of the solid precursors and favouring the subsequent polycondensation reactions to form stable hydrates [205].

Hydroxide-activated mixes can also show increased workability with respect to silicate-activated binders as the hydroxide viscosity is much lower than that of alkali silicate solutions of comparable concentration.

### 3.4.2 Alkali-silicates

Like the hydroxide case, the silicate solutions of interest are those containing sodium and potassium as alkali cations. Sodium silicate (water glass) is the second most used activator solution after sodium hydroxide. The conventional process of manufacturing sodium silicates is via fusion of silica sand and sodium carbonate (Na<sub>2</sub>CO<sub>3</sub>) at about 1100 - 1200 °C to produce a solid glass known as cullet. The cullet is dissolved by mixing it with water under stream pressure, with the final solution product termed water glass.

Sodium silicate also has a strong effect on rheology, because of its high viscosity, and on mechanical strength development. This is due to the reactive silica content of the activator modifying the final composition of the gel and its resulting microstructure. In particular, the presence of soluble silica in the activator promotes the formation of a highly uniform and compact microstructure with very low porosity. When the concentration of silica in the activator is very high the viscosity increases along with a subsequent drop in solution pH. The combined effects result in a decreased degree of reaction [206].

In concentrated alkaline solution, silica partially forms polymeric species from the combination of 2 to 15 monomeric units, with the predominate species being monomer units. The reactivity of these species is a function of the species size, with reactivity decreasing with increasing species size. A solution with a low molar ratio (~ 1) consists primarily of monomers (SiO<sub>4</sub><sup>4-</sup>) and dimers (Si<sub>2</sub>O<sub>5</sub><sup>2-</sup>), while a solution with a high molar ratio (>3) has a higher fraction of polymeric species. The presence and high reactivity of monomers and dimers during alkali activation of precursors promotes the precipitation reactions for gel formation. Further increases in silica monomer concentration can accelerate the precipitation reactions resulting in a less stable gel type. This gel quality dependence

on silica monomer concentration dictates the existence of an optimum value for the molar ratio of the sodium silicate solution when used in alkali activation which happens to be around 1.5 [205].

The monomer  $\text{Si}(\text{OH})_4$  is a polyprotic weak acid with a buffering capacity in the solution pH range of 11-13.5 as so can provide a stable level of available alkalinity with respect to hydroxide solutions of comparable pH, as polycondensation reaction progresses. Hydroxide solutions will have a higher initial pH. However, when sodium silicate is mixed with a solid precursor the progressive dissolution and precipitation of silica from the activator will increase the pH of the solution again, providing new alkaline species [207].

## 4 PERFORMANCE BASED URBCON CONCRETE

### 4.1 Introduction

By means of alkali-activated binder systems, as introduced in [Chapter 3](#), alkali-activated concrete can be made. This concrete made of alkali-activated materials (AAM) can be referred to as AAM concrete or AAC (alkali-activated concrete), though the latter abbreviation is ambiguous as it might be understood as alkali-activated cement (in this e-handbook the term alkali-activated cement has been avoided by using the term alkali-activated binder). Reference in this e-handbook is also made to the term URBCON concrete. This is synonym for AAM concrete that makes use of industrial symbiosis possible in urban areas, so to use local by-products to lower the carbon footprint as well as to avoid primary raw materials (see [Chapter 2](#)). Next to some general considerations of the mix design of AAM concrete, this chapter presents some influencing factors (e.g., precursors, alkali activators, admixtures and curing regimes) and how they affect the fresh and hardened properties of the AAM concrete. As well the durability performance of AAM concrete is discussed, in terms of sulphate resistance, freeze-thaw resistance, carbonation resistance, chloride resistance, and drying shrinkage.

### 4.2 AAM concrete mix

The AAM concrete mix design is quite like that of PC (Portland cement based) concrete. It targets proper workability, mechanical performance, and durability properties. Hereby influencing factors as discussed in the next sections are to be considered with care to optimize the mix design of AAM concrete in view of the targeted concrete performance as desired for specific concrete products or applications.

Concrete can be regarded as a binder system that cements fine and coarse aggregates into an artificial rock. The aggregates in the concrete and the approaches to consider an optimum particle grading of the fine (sand) and coarse (gravel, limestone) aggregates in concrete basically remains the same, irrespective if this is for AAM concrete or PC concrete. Hence, the main difference in the mix design ([Figure 1-1](#)) is associated with the binder paste fraction, that consists of precursors and an aqueous alkali solution in case of AAM concrete, and that consists of Portland cement and water in case of PC concrete. The amount of binder in the concrete is in the same order of magnitude for both AAM concrete or PC concrete, though the dosage of alkali-activated binder is sometimes taken slightly higher. A typical dosage is around  $400 \text{ kg/m}^3$  for AAM concrete versus  $350 \text{ kg/m}^3$  for PC concrete, but this might vary and depends on the specific mix design.

Concretes come in a wide range of mix designs. Mix design procedures (the process of calculating the concrete mix proportions in terms of binder system, sand and coarse aggregate) for PC concrete are well established, e.g. according to EN 206 in Europe and various reference documents that exist on

concrete mix design. Concrete plants have in-house developed or commercial mix design tools for PC concrete in place.

With respect to AAM concrete, current practice is that AAM concrete mixes are optimized in view of local available materials and desired performance characteristics, by concrete technology specialists in companies or academic institutions. These mix designs can be either proprietary or are published in the scientific literature. More general-purpose mix design tools are currently less common for AAM concrete, yet are emerging [208].

As part of the URBCON and DuRSAAM project, several concrete mixes have been developed. Reference to these mixes is made in various sections of this e-handbook. Examples of some of AAM concrete mix designs [kg/m<sup>3</sup>] explored in the URBCON concrete family are indicated in Table 4-1.

*Table 4-1 Exemplary mix designs as explored in URBCON/DuRSAAM [kg/m<sup>3</sup>]*

Materials	R1	R2	C1	C2	C3	C4
Blast furnace slag	357	-	500	125	420	263
Fly ash	-	425	-	-	-	-
Copper slag	-	-	-	215	-	52
Stainless steel slag	-	-	-	60	-	-
CEM I	-	-	-	-	-	35
Quartz sand*	735	670	618	730	690	780
Natural gravel (4-16 mm)*	1100	1645	505	1100	1035	900
Recycled aggregate (4-16 mm)*	-	-	453	-	-	-
NaOH (solid mass)	11	25	22	12	-	-
Sodium silicate (solid mass)	5	70	19	10	-	-
Proprietary activator blend**	-	-	-	-	38	13
Water	157	132	229	153	188	186
R1: RILEM round robin reference (S1b) – medium strength BFS AAM R2: RILEM round robin reference (F8) – medium strength FA AAM C1: targeting C45/55 – S4 – BFS precursor – 50% coarse recycled aggregates C2: targeting 20MPa at 1 day – C50/60 – S4 – blended local precursors C3: targeting C20/25 – S5 C4: targeting C30/37 – self-compacting – hybrid AAM/CEM I * Aggregate fraction (sand + coarse aggregate) is generally adapted to fit an optimum grading curve as e.g. specified in DIN 1045-2 ** Proprietary activator + additives blend tuned for the mix design (might be different per mix design)						

### 4.3 Fresh concrete behaviour

Fresh concrete refers to the concrete that remains in its plastic state. Fresh concrete properties include workability, air content, setting time, etc. Proper fresh concrete properties are required for easy placement and moulding into deigned shapes and play an important role in properties and performance of hardened concrete. The influence of precursor, activators and aggregates on the fresh concrete properties will be presented in this section.

#### 4.3.1 Influencing factors of fresh properties

##### 4.3.1.1 Flow and slump

In AAM concrete, the characteristics of fine/coarse aggregates play a similar role in workability compared to that in conventional concrete, like the modulus of fine aggregates, grading of



fine/coarse aggregates, shape of coarse aggregates, and volume fraction of fine/coarse aggregates. A review paper provides comprehensive information regarding workability of AAM concrete and the influencing factors [209]. Generally, the workability of AAM concrete is lower than that of PC concrete because the silicate in alkali-activator would bring a sticky characteristic. The workability of AAM mortar was reported to be more sensitive to changes in the liquid-binder ratio and the number of aggregates than PC mortars [210]. Detailed evaluation of influencing factors of flow and slump of AAM is presented below (based on research findings in the URBCON and DuRSAAM projects or as documented in literature).

#### 4.3.1.2 Precursors

AAM mortar with fly ash as a precursor had the highest flow compared to other precursors (e.g., slag, silica fume or metakaolin), explained by the spherical shape and slower reaction kinetics of FA [211]. High Ca content in BFS that enabled fast dissolution of ions was one of the reasons for the reduced workability of AAM.

#### 4.3.1.3 Alkali activator solutions

With a certain water-binder ratio, the workability of AAM concrete increases with the amounts of binders (e.g., BFS, FA or MK) and liquid-binder ratio. Besides, the following factors also have noticeable impacts on the workability, i.e. type (e.g. Na or K based) of alkali activator solution, molarity of alkali activator solution, modulus (e.g.  $\text{SiO}_2/\text{Na}_2\text{O}$ ) of alkali-activator solution, Workability of AAM concrete decreased with the increasing molarity of alkali-activator.

The activator type has a pronounced effect on the workability of alkaline binders. For example, sodium silicate and sodium hydroxide influence the overall workability. The slump and flow decrease with increased modulus of water glass because of the high viscous nature of sodium silicate [212][213].

Potassium-based activator was reported to provide better flowability than sodium-based activator [214][215]. The workability of AAM concrete (slag based) increased with the amount of alkali activators (3.5%-7.5% by mass of slag in the study) and the modulus (0.45–1.05 in the study) of activator solutions, while the setting time was reduced [216].

Figure 4-1 and Figure 4-2 present the initial slump, flow, and slump retention of a type of URBCON concrete. The URBCON concrete is a blast furnace slag concrete activated with NaOH and water glass, containing 50% recycled aggregates from construction demolition wastes. The slump fulfils workability S4 requirement and the slump retention of the concrete over time is satisfactory. The air content is 1.8%.



Figure 4-1 Initial slump (left) and initial flow (right) of a type of URBCON concrete

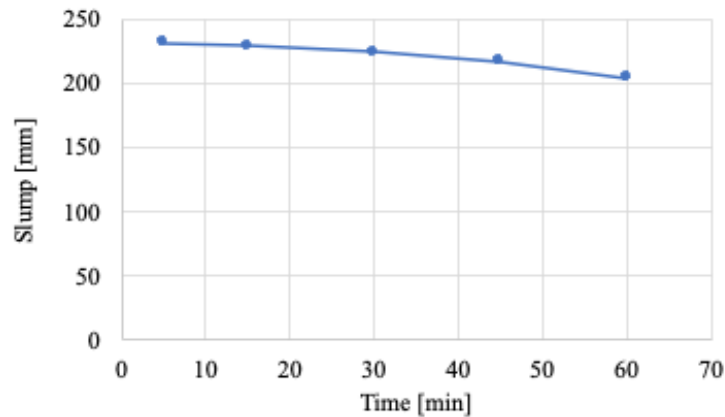

Figure 4-2 Slump retention of one type of URBCON concrete over time

#### 4.3.1.4 Superplasticizers

The effect of superplasticizers (polycarboxylates, vinyl copolymers, melamine and naphthalene-based) on alkali-activated slag pastes and mortars differs entirely from the effect on PC mixtures. The reason for this difference lies in the modifications that high alkaline media, such as water glass and NaOH solutions, induce in the chemical structures of some of the admixtures used. One type of naphthalene-based superplasticizer was reported to improve the workability and mechanical properties of NaOH activated slag pastes, which also caused retardation of the initial and final set times compared to slag pastes and mortars with no admixtures [217].

Different types of commercial superplasticizers, such as naphthalene, melamine and modified Polycarboxylate, were evaluated based on the workability of a class F fly ash geopolymer paste activated by two different activator combinations, i.e., sodium hydroxide solution and a multi-compound activator composed of NaOH and water glass. The effect of different superplasticizers on the workability and strength of fly ash based geopolymer directly depended on the type of activator and the superplasticizer. In the case of using NaOH solution as the activator, naphthalene-based superplasticizer was an effective type; whereas modified Polycarboxylate based superplasticizer was the most efficient type when the multi-compound activator was used [213].

The polycarboxylate-based superplasticizer was also reported to show retarding effect on alkali-activated fly ash/slag pastes with negligible effect on the heat of hydration and improved the workability more significantly than naphthalene-based superplasticizer [218].

The stability of superplasticizers is a critical issue for alkali-activated materials due to the high pH. In silicate activators, silicate groups can destroy  $-SO_3$  in superplasticizer molecules, such as melamine, sodium lignosulfonate and naphthalene-based superplasticizers. There are almost no superplasticizers that can improve the workability of  $Na_2CO_3$  activated slag. Polycarboxylether containing poly (ethylene oxide) side chains becomes insoluble with increasing sodium hydroxide concentration and is basically insoluble in sodium carbonate activator. In NaOH-activated slag systems, lignosulfonate and HPEG-type superplasticizers with high charge density and short side chain length are effective in improving the workability, retarding the setting time, and increasing the strength of alkali-activated slag (AAS). In one-part  $Na_2SiO_3$ -activated slag, polycarboxylate-based is the most effective admixture compared to melamine-based and naphthalene-based in anhydrous  $Na_2SiO_3$  one-part AAS. Only lignosulfonate and naphthalene-based superplasticizers can slightly improve the workability of water glass-activated slag systems [219].

### 4.3.2 Setting time

The initial setting time of concrete is the time when paste starts hardening, while the final setting time is the time when paste has hardened sufficiently. Setting behaviour is controlled by many factors including raw materials, mix design and curing regimes, etc. Detailed evaluation of influencing factors of setting time of AAM is presented below.

#### 4.3.2.1 Precursors

The setting time of slag-based alkali binders was found to decrease with increasing calcium content, where Ca was considered as a network modifier accelerating the rapid dissolution of available precursors [220]. The setting can be prolonged when fly ash and/or metakaolin was used to replace some amount of BFS [221][173]. In alkali-activated metakaolin system, the inclusion of calcium rich pozzolans such as GGBS and PC can have a profound effect on setting time, which can be attributed to either the abundantly available  $\text{SiO}_2$  and  $\text{Al}_2\text{O}_3$  in metakaolin or an increase in CaO from the PC [222][223]. However, compared to 100% MK, the inclusion of PC increases setting time substantially, explained by the high fineness and plate-like morphology of metakaolin that causes a faster polymerization [224][225]. Contrary to micron-sized FA, the inclusion of ultrafine FA was also found to significantly shorten the setting time of AAM [226]. Nano silica particles were found to increase the setting time of alkali-activated FA system [227][228].

#### 4.3.2.2 Alkali activator solutions

It was reported that the alkali activator-precursor ratio showed a significant influence on the setting time of AAM while liquid-to-binder ratio showed only a minor effect [229]. The setting of AAM is determined by the dissolution process and reaction process of precursors and alkali activators. The initial slag dissolution is highly favoured by pH values  $> 12$ . The anion type of alkaline activator is another important factor. Longer setting times were observed using NaOH activator compared to  $\text{Na}_2\text{SiO}_3$  activator [230]. NaOH in silicate-based activators decreases the degree of polymerization of silicate ions and reduced the concentration of calcium ions in pore solution, which results in a longer initial setting time. It can be explained by the fact that silicate ions in alkali activator can react with the  $\text{Ca}^{2+}$  ions dissolved from the slag for generating reaction products. The initial and final setting time was found to decrease considerably with increased molarity of NaOH activator [231]. However, when  $\text{Na}_2\text{CO}_3$  is incorporated in activator, carbonate ions can extend the setting time, attributed to lower pH in the solution and to the initial formation of sodium–calcium–carbonate [232].  $\text{Na}_2\text{CO}_3$  in silicate-based activators does not alter the degree of polymerization of silicate ions. The delay of initial setting is attributed to the reactions between calcium ions from slag and carbonate from activator to form calcium carbonate. However, the initial setting time is shortened when  $\text{Na}_2\text{CO}_3$  in NaOH-based activators, due to the precipitation of  $\text{Na}_2\text{CO}_3 \cdot 10\text{H}_2\text{O}$  crystal [233].

#### 4.3.2.3 Chemical admixture - retarders

Many commercial retarders for PC system have been proven ineffective in alkali-activated slag (AAS) system due to different reaction kinetics [233]. Fortunately, tartaric acid and  $\text{CaSO}_4$  were proven to significantly retard the hydration of NaOH-activated slag. The setting time of silicate-activated slag is more difficult to prolong compared with NaOH-activated slag. A small amount of nano-zinc oxide and zinc nitrate can also significantly increase the setting time but can negatively affect the strength development. In summary, retarders suitable for AAS systems are boric acid/borax and phosphoric acid/phosphate, which may cause a minimal decrease in strength with a reasonable dosage. The retardation mechanism of these materials was related to the consumption of calcium ions in the pore solution, which reduced the precipitation and growth of C-(A)-S-H [219].

## 4.4 Hardened concrete behaviour

The mechanical properties of concrete specimens are considered as one of the most important factors while designing a concrete structure. The mechanical properties of concrete specimens are determined by performing a set of tests such as compressive strength, flexural tensile strength, splitting tensile strength and E-modulus. Among the mentioned tests, compressive strength of concrete mixtures is considered as the most relevant mechanical property for the structural engineers. Within the framework of the URBCON and DuRSAAM projects, the mechanical properties of different alkali-activated concrete mixtures were studied. To this end, the influence of different parameters including the solid precursors, water to binder ratio,  $\text{Na}_2\text{O}$ / binder ratio and  $\text{SiO}_2/\text{Na}_2\text{O}$  ratio, on the compressive strength of the concrete mixtures is presented in the following sections.

### 4.4.1 Influence of type of solid precursors

The mechanical properties of alkali-activated concrete mixtures can be influenced by the type of solid precursors used to produce them due to the differences in their physical properties and chemical compositions [234]-[239]. From the physical properties point of view, the particle size distribution of the solid precursors plays an important role in the strength development of the alkali-activated systems [234]-[237], as the AAMs made of finer precursors show higher strength properties. From the perspective of the chemical composition, the presence of silicate and alumina in the aqueous phase of the alkali-activated systems is necessary to initiate the formation of oligomeric precursors and polycondensation, which is a key factor affecting the strength development of AAMs [238][239]. Therefore, the solid precursors with higher contents of silicate and alumina and a larger ratio of Si/Al show better strength properties. With respect to this, the concrete mixtures with higher amounts of GGBFS displayed better mechanical properties compared to other mixtures containing copper, stainless steel slag and fly ash.

### 4.4.2 Influence of water to binder ratio

One of the key factors affecting the mechanical properties of alkali-activated concrete mixtures is the water to binder (w/b) ratio used to produce them [240]-[243]. The strength properties of the alkali-activated concrete mixtures decrease using higher w/b ratio regardless of the solid precursor used to produce them, showing that the effect of the w/b ratio in these systems follows the general trend seen in the traditional concrete. To understand this trend, two important aspects need to be considered. Firstly, considering that all the other factors affecting the activator solutions are constant and the only difference is caused by the w/b ratio, consuming extra water to produce the concrete mixtures dilutes the alkalinity of the activator solution, leading to the reduction of the reaction rate of the hydration process and consequently lower strength values. In addition, consuming extra water, while the amount of the cementitious materials are constant leads toward the easier generation of the water film on the aggregate surface and consequently weakens the binding force at the sand and slurry interface [241]. Figure 4-3 shows the influence of w/b ratio on the compressive strength of alkali-activated slag and fly ash-based mixtures [244].

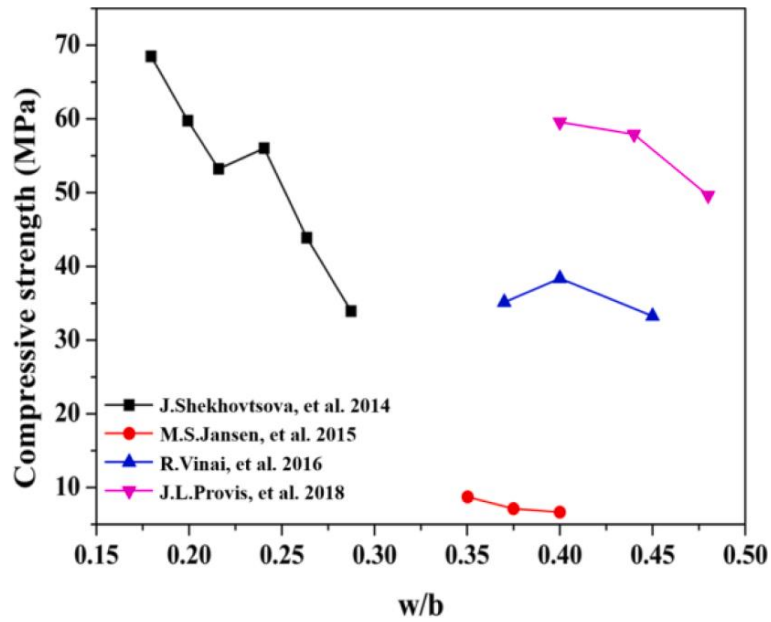

Figure 4-3 Effect of water/binder ratio on the compressive strength of slag and fly ash-based alkali-activated materials [244]

#### 4.4.3 Influence of Na<sub>2</sub>O/binder ratio

The Na<sub>2</sub>O/ binder (Na<sub>2</sub>O/b) ratio can be considered as one of the parameters affecting the mechanical properties of the alkali-activated concrete mixtures [240]. Normally, using higher Na<sub>2</sub>O/b ratio up to a certain amount increases the strength properties of the concrete mixtures, which can be attributed to the increase in the solubility of the solid precursors because of the increase in the alkali content (Na<sub>2</sub>O concentration) of the activator solution, resulting in the production of more binding gels and consequently higher strength. It has been reported that the optimum value of Na<sub>2</sub>O/binder ratio in slag and fly ash-based alkali-activated materials is 5.50-8.00% and 7-10%, respectively [244]. The influence of the Na<sub>2</sub>O/ b ratio on the compressive strength of alkali-activated materials is given in Figure 4-4.

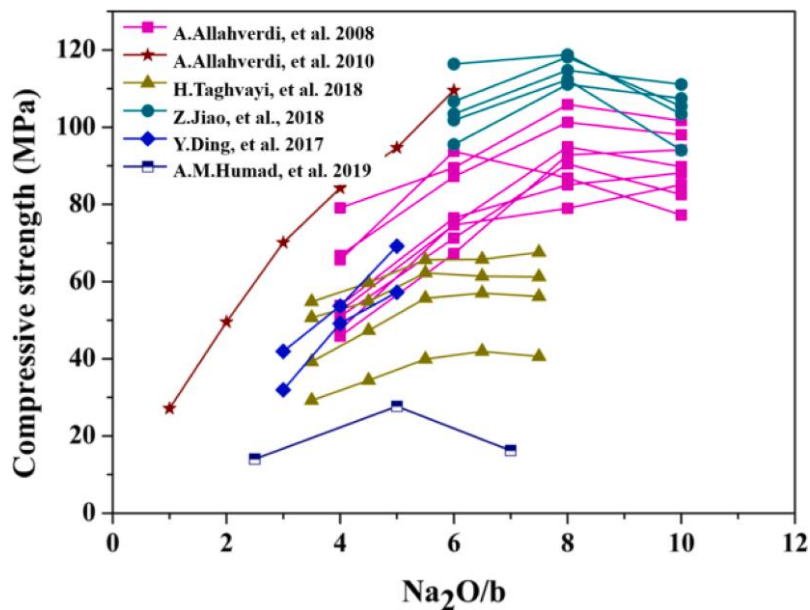

Figure 4-4 Effect of Na<sub>2</sub>O/binder ratio on the compressive strength of slag and fly ash-based alkali-activated materials [244]



#### 4.4.4 Influence of SiO<sub>2</sub>/Na<sub>2</sub>O ratio

Using higher ratios of SiO<sub>2</sub>/Na<sub>2</sub>O (molar ratio), results in a denser microstructure of the alkali-activated materials due to the more reaction products that are formed in the solution. The effect of the SiO<sub>2</sub>/Na<sub>2</sub>O ratio should be considered along with the Na<sub>2</sub>O/binder ratio. The highest strength properties are obtained, when the erosion rate of OH<sup>-</sup> and the absorption rate of soluble Si reach a specific balance, and when the amount of supplied soluble Si and existing Si reaches a specific proportion [244]. The influence of the SiO<sub>2</sub>/Na<sub>2</sub>O ratio on the compressive strength of alkali-activated materials is given in Figure 4-5.

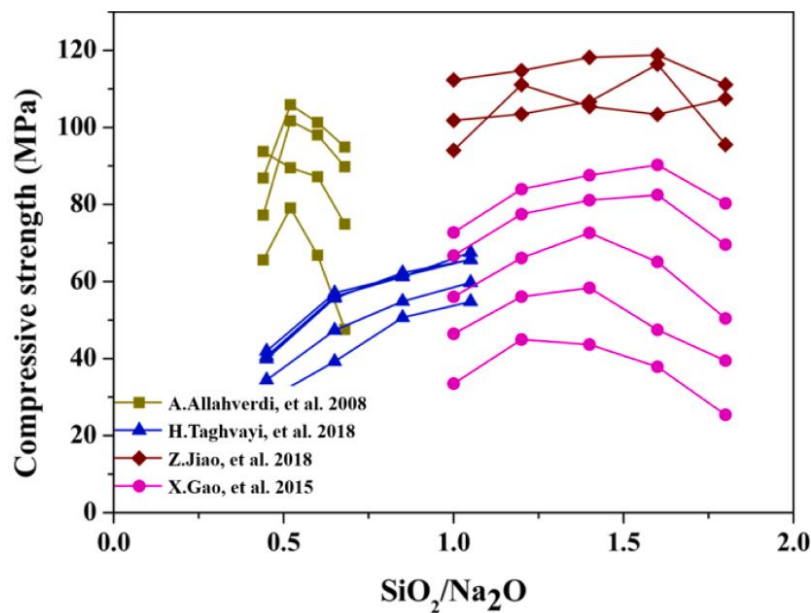

Figure 4-5 Effect of SiO<sub>2</sub>/Na<sub>2</sub>O ratio on the compressive strength of slag and fly ash-based alkali-activated materials [244]

#### 4.5 Durability of alkali-activated concrete

Much research has been already conducted on the durability of alkali-activated concrete, in view of service life of AAM concrete products and structures. Nevertheless, the knowledge on AAM concrete durability is not yet as fully established as PC concrete. The durability of concrete can be challenged by chemical and physical attack, either separately or in combination. Even though the AAM microstructure and chemistry are somewhat different from PC based materials, the main mechanisms of attack are believed to remain similar. Yet, as concrete durability is governed amongst other by the raw materials, mix design and exposure condition, the durability of AAM concrete may vary from that of PC concrete.

In reinforced concrete applications, one of the main service-life limiting factors is potential carbonation- or chloride-induced corrosion of the steel rebars inside the concrete. As such, carbonation and chloride ingress resistance are of concern also for AAM concrete. Further to that and depending on the application, aspects such as resistance against freeze-thaw, sulphate attack and alkali-silica reaction (ASR) can be of interest. Excess of drying shrinkage can lead to shrinkage cracking and is also of concern. These different durability aspects are discussed in the following sections. Note that this discussion is not covering all possible durability aspects, and more information is available in the specialised literature. A critical review on durability of alkali-activated materials can be found in literature [246]-[248].



## 4.5.1 Carbonation

### 4.5.1.1 Carbonation process and its consequences

Carbonation is the reaction between atmospheric CO<sub>2</sub> and cementitious materials. Even if the carbonation process is slow, around a few millimetres per year, it is still one of the main durability challenges for concretes in service. In PC based materials, the carbonation results in a pH drop leading to the potential corrosion of the steel rebar in reinforced concrete. The corrosion products that form on steel rebar have a higher volume and can cause cracking of the concrete. Previous work has shown that AAM carbonation consequences are slightly different from those of PC carbonation. Although the consequences of AAM carbonation depend on the mix design, past studies show that, in these materials, it is possible that the pH drop is not low enough to lead to steel corrosion. However, the mechanical performance may decrease.

### 4.5.1.2 Test methods

To overcome the lack of service life data on AAM carbonation, there remains a need for an efficient and accurate standard test method to evaluate AAM carbonation, as the use of methods designed for measurement of PC carbonation may lead to inaccurate predictions.

### 4.5.1.3 Carbonation behaviour of AAC

Carbonation of concrete is a coupled process of transport and reaction. The CO<sub>2</sub> transports into concrete by convection or diffusion, in the meantime the chemical reaction takes place between the carbonic acid and the reaction products of concrete in presence of water, producing carbonate deposits [249]. Carbonation leads to a decreased pH in concrete, and possibly reduces strength and increases total porosity. This may further lead to initiation of rebar corrosion and early failure of concrete structures [250]. Figure 4-6 presents an example of carbonation depth of a type of URBCON concrete (a blast furnace slag concrete activated with NaOH and water glass, containing 50% recycled aggregates from construction demolition wastes) using accelerated carbonation testing methods.

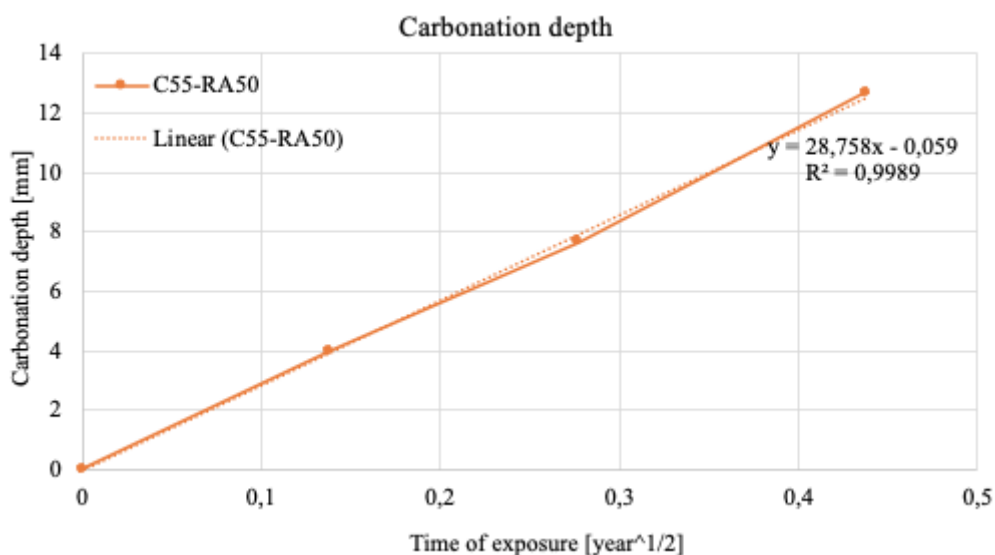

Figure 4-6 Carbonation depth of a type of URBCON concrete under an environment of 60% relative humidity and 1 % CO<sub>2</sub> concentration

Carbonation resistance of alkali-activated slag is often reported lower compared to Portland cement systems, explained by the absence of portlandite and the decalcification of C-A-S-H type gels, etc. [251]-[253]

Carbonation is influenced by CO<sub>2</sub> concentration, relative humidity, pore structure, pore solution and reaction products of alkali-activated concrete. The carbonation resistance of alkali-activated concrete highly depends on the type of precursors (e.g. blast furnace slag and fly ash) [132] and the type and concentration of alkali activators [251]. Slag with higher MgO content leads to a higher carbonation resistance of concrete due to the high absorption capacity of CO<sub>2</sub> by layered double hydroxides formed in concrete [254].

Higher binder content in alkali-activated slag concrete increases carbonation resistance, accompanied by increased compressive strength and permeability [255][8]. In alkali-activated slag/fly ash systems, carbonation resistance decreases with increasing GBFS content [256]. Increasing metakaolin content in the binder of alkali-activated slag system leads to a reduction in mechanical strength and a lower carbonation resistance [257].

Carbonation resistance of the alkali-activated mortars increases with increasing alkali dosage and silicate modulus, explained by higher pore solution alkalinity, higher activation rate of slag, lower porosity and more refined pore structure [132][258]. Carbonation of C-(A)-S-H phase in water glass activated slag mortars leads to reduced molar volume of solids, increased total porosity and average pore size, subsequently reduced compressive strength [258].

The type of alkali activator plays a role in the carbonation process. When water glass was used as alkaline activator, carbonation caused an increased porosity and decreased strength. When a NaOH solution was used as the alkali activator, carbonation decreased porosity and increased strength [252], because carbonation of C<sub>3</sub>AH<sub>6</sub> phase in NaOH activated slag mortars leads to increased molar volume of solids [258].

It is noted that the type of reaction products by carbonation highly depends on the CO<sub>2</sub> concentration. Accelerated carbonation tests usually specifies much higher CO<sub>2</sub> concentration (e.g. above 1%) than natural condition (e.g. 0.04% ). The pore solution chemistry in carbonated alkali-activated concrete in accelerated carbonation tests may contain NaHCO<sub>3</sub> or Na<sub>2</sub>CO<sub>3</sub>.NaHCO<sub>3</sub>.2H<sub>2</sub>O, while under natural condition the pore solution chemistry contains Na<sub>2</sub>CO<sub>3</sub>.10H<sub>2</sub>O with a higher pH value [259]. Since the pH value in carbonated alkali-activated concrete is closely related to rebar corrosion, the correlation of the results between accelerated tests and natural tests appears to be a topic that needs further investigation [260].

#### 4.5.2 Chloride resistance

Chloride is closely related to rebar corrosion in reinforced concrete. When chloride content at the surface of the rebar exceeds a critical value, depassivation of rebar will take place, resulting in initiation of rebar corrosion. The chlorides may come from the raw materials or external environment. Chloride transport in concrete includes two processes, namely chloride diffusion/convection and chloride binding.

The chloride resistance of concrete is a parameter that describes the ability of concrete against chloride ingress, and can be assessed by several methods, e.g. rapid chloride permeability test (RCPT) according to ASTM Standard C1202, non- steady-state migration (NSSM) according to NT Build 492 or EN 12390-18, chloride diffusion test according to EN 12390-11 and ponding test according to ASTM standards [246].

Both Ca-rich precursor in fly ash and slag-based alkali-activated materials cause higher chloride resistance by reducing alkali mobility and leaching of alkalis [288]. Fly-ash/slag-based geopolymer paste has refined pore structure and high tortuosity [289], and shows higher chloride resistance than Portland cement paste [290]. Critical pore size is reported more influential than porosity in determining the chloride transport properties of alkali-activated slag concrete [291]. For alkali-activated fly ash concrete exposed to a chloride environment under wet-dry cycles, much less

amount of corrosion products is observed at the matrix/rebar interface, compared to PC counterparts [292]. Alkali-activated slag mortar/concrete shows much higher chloride resistance than PC specimens even though AAS mortar/concrete may exhibit higher water absorption than PC-based specimens, ascribed to possible micro-cracking of alkali-activated slag specimens due to preconditioning (drying) of the specimens prior to the water absorption tests [293]. Incorporation of slag in fly-ash-based geopolymers leads to improved chloride resistance [290]. A denser Al-substituted calcium silicate hydrate (C-A-S-H) gel in alkali-activated slag concrete contributes to a higher durability under chloride exposure, while the inclusion of fly ash result in more porous microstructure, reducing the chloride resistance [293].

Higher Na<sub>2</sub>O/precursor ratio and SiO<sub>2</sub>/Na<sub>2</sub>O ratio in the activator lead to lower porosity and more refined pore structure. Thus higher chloride resistance of sodium silicate- activated slag or fly ash concrete (see Figure 4-7) [294]-[297]. Alkali silicate in powder form is reported to cause more-refined pore structure of alkali silicate-activated slag and show better resistance to chloride transport compared to the mixture made of liquid water-glass-activated mixture [294].

Sorption of chlorides by the reaction products (e.g. layered double hydroxide phases) in some alkali-activated materials accounts for chloride binding [290]. Small addition of calcined layered double hydroxide (CLDH) is reported beneficial for increasing the degree of hydration, refining pore structure, and thus improving chloride binding capacity and chloride resistance of sodium carbonate-activated slag mortars [298].

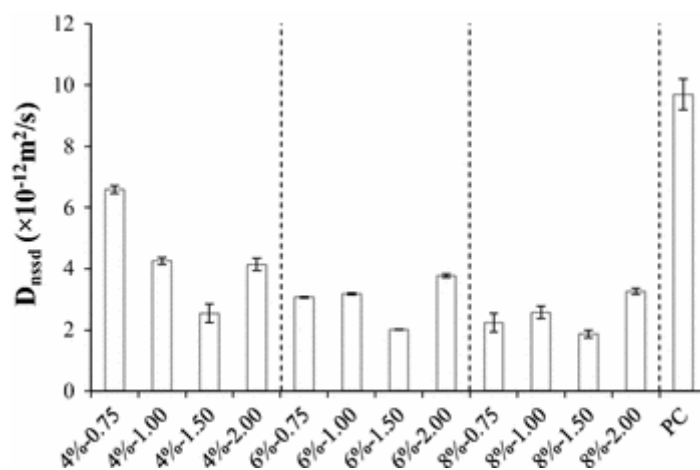

Figure 4-7 Non-steady state chloride diffusion coefficients of the concretes (“4%-0.75” stands for concrete made of 4% Na<sub>2</sub>O by mass of binder and the modulus 0.75 of water glass) [297]

#### 4.5.3 Sulphate resistance

Sulphate attack is a common form of chemical attack to conventional concrete when the concrete is applied in marine or underground environment. The chemical consequences of sulphate attack of conventional concrete are formation of ettringite due to the reaction between C<sub>3</sub>A and sulphate, and formation of gypsum due to the reaction between Ca(OH)<sub>2</sub> and sulphate [261][262]. Both the ettringite and gypsum cause expansion in concrete. The sulphate attack of concrete may result in cracking, and further reduced mechanical properties and durability [263]. Pozzolans, like fly ash, silica fume, metakaolin and latent hydraulic materials like blast furnace slag, can be employed to improve the resistance of conventional concrete to sulphate attack, because the pozzolans consume Ca(OH)<sub>2</sub> that is needed for reaction with sulphates. Moreover, in blended cement concrete the total amounts

of  $C_3A$  and  $Ca(OH)_2$  are reduced due to the replacement of cement with pozzolans and latent hydraulic materials [264].

The mechanisms of sulphate attack on alkali-activated concrete are different from that for conventional concrete. The consequences of sulphate attack on alkali-activated concrete strongly depend on the nature of the cation accompanying the sulphate. It has been reported that  $Na_2SO_4$  does not lead to any significant degradation of alkali-activated concrete. It was explained by the fact that  $Na_2SO_4$  acts as an activator, rather than as an aggressive agent. However,  $MgSO_4$  caused severe damage to alkali-activated slag concrete by decalcification of the calcium-aluminosilicate hydrate (C-A-S-H) to magnesium-aluminosilicate-hydrate (M-A-S-H) and formation of gypsum [265].

When alkali-activated slag concrete is subjected to sulphate attack in 5%  $Na_2SO_4$  solution, the concrete has a higher sulphate resistance compared with PC concrete or Portland-slag cement (CEM II/A-S 42.5N) (see Figure 4-8). This has been attributed to the absence of  $C_3A$  and portlandite in alkali-activated concrete [266][267]. It is also reported that alkali-activated slag concrete shows better sulphate resistance than PC when submerged in 10%  $Na_2SO_4$  solution, but worse sulphate resistance than PC when submerged in 10%  $MgSO_4$  solution [268].

A lower water/binder ratio of alkali-activated fly ash/slag paste leads to an enhanced resistance to sulphate attack [265]. Increased dosage of activator could improve the sulphate resistance of  $Na_2SiO_3$ -activated slag/fly ash due to the reduced porosity, enhanced compressive strength [269]. The alkali activators also play a role in sulphate resistance of alkali-activated concrete. Compared to  $Na_2SiO_3$ -activated slag mortars, the NaOH-activated slag mortars are more vulnerable to sulphate attack due to higher structural order, less polymerization and higher Ca/Si ratio. The decrease in strength is due to the formation of gypsum and ettringite [270].

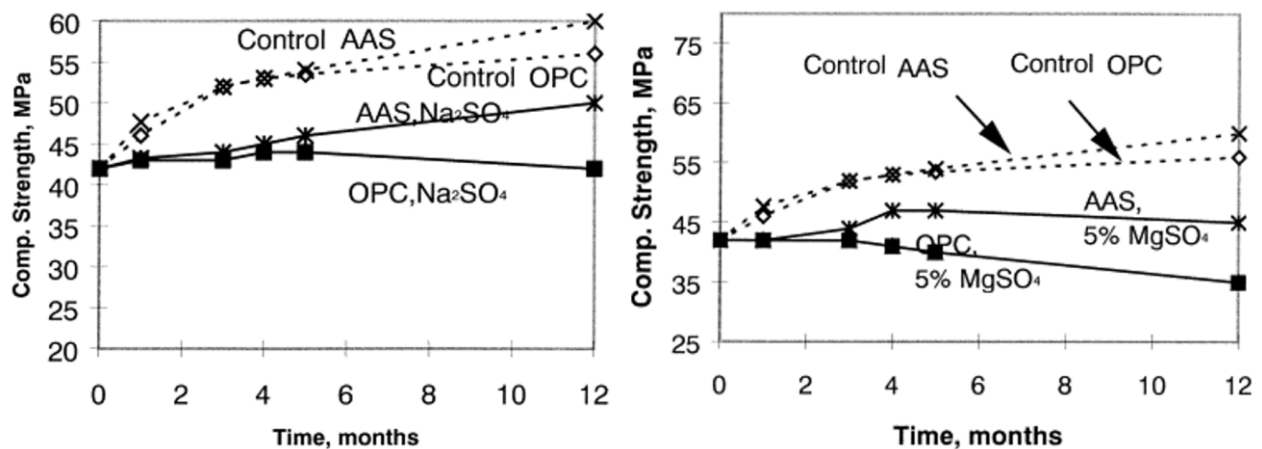

Figure 4-8 Compressive strength of PC concrete and AAS concrete subjected to  $Na_2SO_4$  (a) and  $MgSO_4$  solution (b) [267]

Low-calcium alkali-activated systems, e.g. fly ash-based geopolymer and kaolinite-based geopolymer generally show excellent sulphate resistance [271]-[273]. It is explained by the formation of a more stable zeolitic structure, which enhances the strength and sulphate resistance of geopolymer [274]. NaOH activated fly ash concrete is reported to have the best sulphate resistance, explained by the stable cross-linked aluminosilicate polymer structure, compared to fly ash concrete activated by  $Na_2SiO_3$  or a mixture of NaOH and KOH [275]. Unlike high-calcium alkali-activated systems, the low-calcium alkali-activated systems are generally more resistant to  $MgSO_4$  than  $Na_2SO_4$  [275]. More research is needed to clarify the underlying mechanisms.

#### 4.5.4 Freeze–thaw resistance

Water expands about 9 percent when it freezes. For a saturated concrete subjected to freeze-thaw cycles, stress can develop in pore space, increasing the potential of cracking, scaling, and crumbling of the concrete. The mechanical property and microstructure of alkali-activated concrete are two of the important factors affecting the freeze-thaw resistance. The mechanisms of freeze-thaw process in alkali-activated concrete are mainly based on hydrostatic and osmotic pressure theory [276]. There is no clear relation between strength and freeze-thaw resistance of alkali-activated concrete. Alkali-activated concrete with high strength may show very low freeze-thaw resistance [277]. Figure 4-9 presents an example of the mass loss of a type of URBCON concrete (blast furnace slag concrete activated with NaOH and water glass, containing 50% recycled aggregates from construction demolition wastes) after freeze-thaw cycles using the CDF test (capillary suction of deicing chemicals and freeze-thaw test).

Fly-ash-based or slag-based alkali-activated concrete has been reported to be considerably resistant to frost exposure, in comparison to PC-based specimens [278]-[280]. On the contrary, alkali-activated concrete made with BFS, fly ash or metakaolin are also reported to have weak freeze-thaw resistance [281]. An example of comparison of freeze-thaw resistance between different mortars is shown in Figure 4-10 [282][283]. Polypropylene fibres do not have a significant effect on freeze-thaw resistance of alkali-activated mortars [283]. The experimental conditions, including curing of the specimens, have significant influence on the outcomes of freeze–thaw resistance tests of alkali-activated concretes [281].

Alkali-activated concrete with a lower water-to-slag ratio has a higher freeze-thaw resistance [284]. The lower solution to slag ratios and higher slag content are beneficial for freeze-thaw resistance. A smaller air bubble space coefficient and a bigger specific surface area of alkali-activated materials lead to high freeze-thaw resistance [285]. The frost resistance of alkali-activated concrete increases with slag portion in the binder (i.e., natural pozzolan and slag). An increase in sodium silicate dosage leads to improved frost resistance of concretes made with binders having 50 and 70% slag, the frost resistance is significantly higher than that of the reference Portland cement concrete. The alkali-activated concrete with 30% slag as precursor is equal to or less than that of the reference Portland cement concrete, depending on sodium silicate content [286].

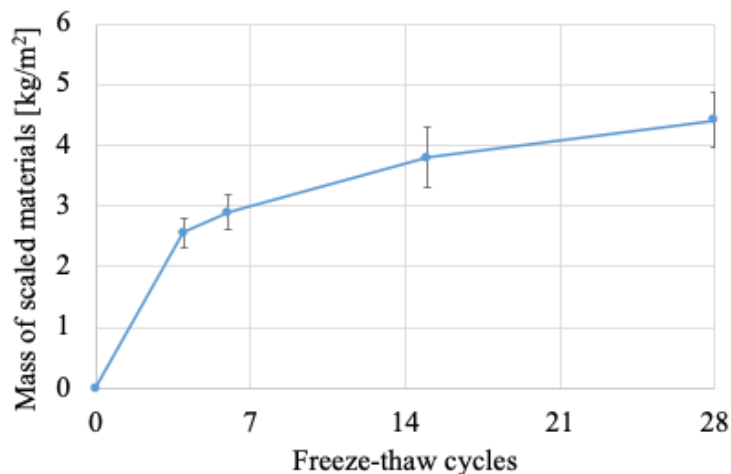

Figure 4-9 Freeze-thaw resistance of a type of URBCON concrete following CDF testing method

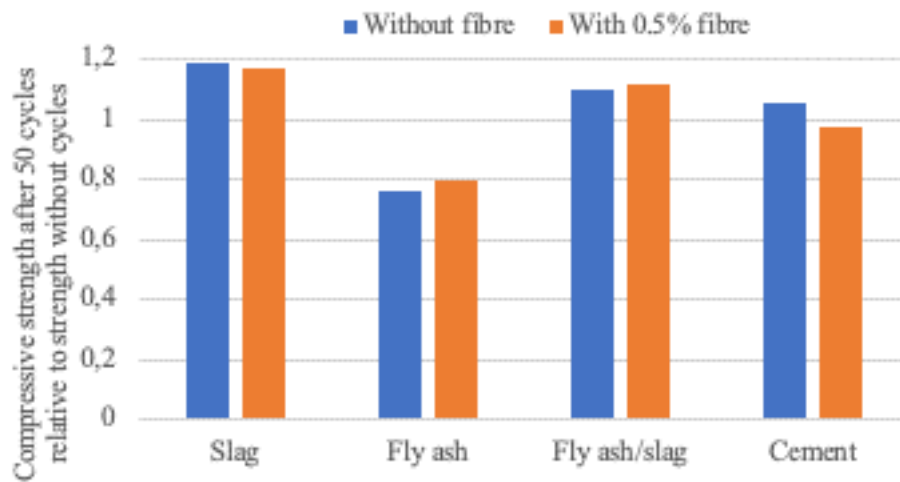

Figure 4-10 Compressive strength of AAM and PC mortar with/without polypropylene fibres after 50 freeze-thaw cycles in water relative to original strength before cycling (adapted from [283])

For metakaolin-based alkali-activated materials, the freeze-thaw resistance decreases with an increasing Si/Al ratio and a decreasing Na/Al ratio. The frost resistance of alkali-activated concrete has a positive correlation with the Na<sub>2</sub>O equivalent content. The freeze-thaw resistance for geopolymer concretes could be increased by some air entraining agents. The frost resistance of alkali-activated concrete was improved by some chemical admixtures, in the order of sodium lauryl sulphate > sodium dodecyl sulphate > sodium arsenate [282][283]. However, it should be noted that common air-entraining agents have poor compatibility in high-alkaline, high-viscosity fresh alkali-activated concrete [286][287].

#### 4.5.5 Drying shrinkage

In general, alkali-activated binders have higher drying shrinkage compared to cement-based materials (see Figure 4-11), because in alkali-activated binders the water does not incorporate directly in aluminosilicate gel and is more prone to evaporation, crystal phases like CH is absent from alkali-activated binders, and capillary pressure is very high in the refined pore structure [248][299]-[301]. Microcracking induced by drying shrinkage can be a critical issue for alkali-activated materials [302] and minimize their applications in construction industry [303]. Fortunately, by proper mix design alkali-activated concrete can show a lower drying shrinkage than that of cement-based concrete [304][305]. Figure 4-12 presents an example of drying shrinkage of a type of URBCON concrete (blast furnace slag concrete activated with NaOH and water glass, containing 50% recycled aggregates from construction demolition wastes).

Replacing slag by fly ash reduces drying shrinkage of alkali-activated concrete, improves the workability, and prolongs the setting time. However, it reduces the compressive strength [306]-[309]. The reduced drying shrinkage is explained by the fact that the aggressive removal of water of hydration from C-S-H-type gels in alkali-activated slag causes severe damage, while in alkali-activated slag/fly ash the removal of physically bound (similar to zeolitic) water from alkali aluminosilicate gels causes less severe consequences [310]. Increasing slag content in alkali-activated slag and metakaolin also leads to increased compressive strength, drying shrinkage and cracking potential [311]-[312]. Increasing the content of fly ash in metakaolin/fly ash geopolymer decreases the drying shrinkage [313]. Using hybrid slag and metakaolin greatly reduced the drying shrinkage, as compared to the alkali-activated slag and alkali-activated metakaolin [314]. Increasing the fineness of high calcium fly ash leads to reduced drying shrinkage and increased compressive strength in the AAFA mortars [236].



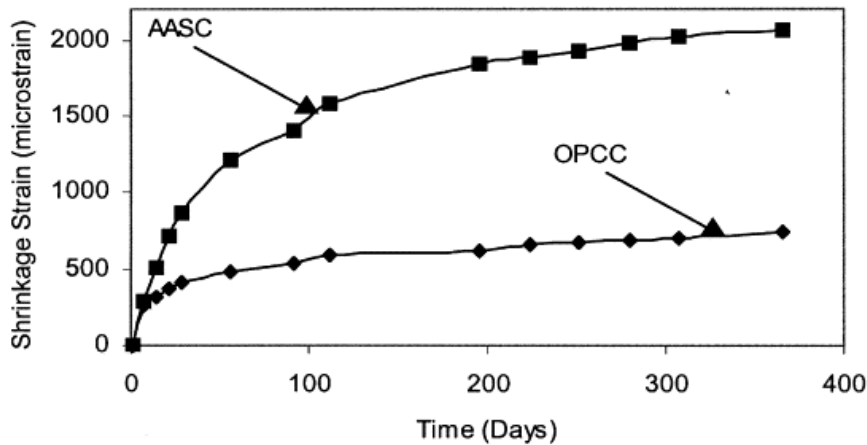

Figure 4-11 Drying shrinkage of PC and AAM concrete, exposed from day 1 onwards to 50% RH and 23°C. w/h=0.5 [299]

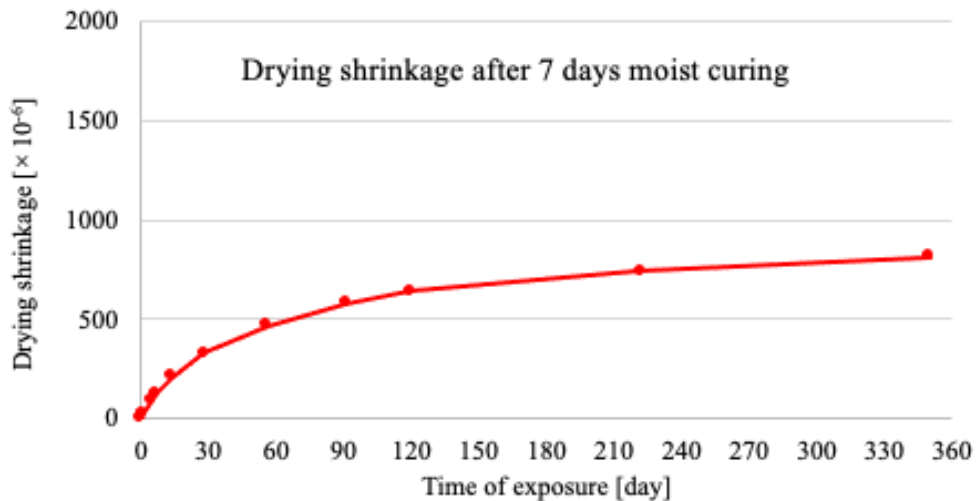

Figure 4-12 Drying shrinkage of a type of URBCON concrete under 50% relative humidity at 20°C

Compared to cement-based mortar, slag mortar activated with sodium silicate shows much higher compressive strength and drying shrinkage. Slag mortar activated with sodium hydroxide shows a lower compressive strength but still has a moderately higher drying shrinkage. Slag mortar activated with sodium carbonate shows a lower compressive strength and comparable drying shrinkage [201].

Replacing  $\text{Na}^+$  ions with  $\text{K}^+$  ions in the activators leads to decreasing the minimum required structural amount of water and maintaining the structural stability of pastes [315]. The activator modulus and concentration has been reported to have a major effect on the drying shrinkage rate [316]. Increasing the amount and the  $\text{SiO}_2/\text{Na}_2\text{O}$  molar ratio of the activator increases the drying shrinkage of alkali-activated slag due to intensified hydration, refined pore structure and increased capillary pressure [218][236][302]-[311][317]-[319].

Different from the case of alkali-activated slag, increasing activator concentration decreases the shrinkage of AAFA [236][306][320][321]. Reducing the amount of sodium silicate in the alkali activator is reported to reduce the drying shrinkage in alkali-activated fly ash [322].

The shrinkage of alkali-activated materials can be significantly decreased by fibre reinforcement. Steel fibre has a higher efficiency than polypropylene fibres in mitigating drying shrinkage of alkali-

activated fly ash [323]-[325] and alkali-activated slag/fly ash [326][327]. Polypropylene fibre is reported to decrease the drying shrinkage of metakaolin/fly ash geopolymer [328]. Additives, like nano-TiO<sub>2</sub> [329], shrinkage reducing agent [330]-[332], and expanding admixtures [333][334] are reported to reduce drying shrinkage of alkali-activated slag and alkali-activated fly ash.

Water curing decreases drying shrinkage of alkali-activated slag concrete compared to air curing. Heat curing greatly accelerates strength development at early ages and reduces the drying shrinkage of alkali-activated slag [300][335] and alkali-activated fly ash [319].

For alkali-activated metakaolin/fly ash mortars and PC mortar with the same strength class, alkali-activated mortars have a higher drying shrinkage compared to PC mortars. But the restrained shrinkage in the alkali-activated mortars is lower than in the PC mortar due to the lower modulus of elasticity of alkali-activated mortars [336]. Therefore, cracking potential of alkali-activated materials is another important parameter besides the drying shrinkage.

#### 4.5.6 Alkali-silica reaction

In PC concrete alkali-silica reaction (ASR), under certain conditions (eg. enough water and alkali have to be present), takes place between the aggregates, containing potentially reactive amorphous silica, and the highly alkaline cement paste. ASR results in an expansive reaction which leads to cracking and degradation of the concrete over time. Likewise, practicing engineers might have concerns about the ASR resistance of AAM concrete (especially because alkali is explicitly used in the mix design, though this alkali-activator is in principle consumed in the AAM binder reactions).

In [245] ASR is discussed both for PC and AAM concrete. Like PC concrete, in AAM concrete mitigation measures to avoid or limit the effect of ASR should be taken, among which avoiding the use of reactive aggregates. Given the good performance of ground granulated furnace slag in counteracting ASR in PC concrete, the selection of ground granulated furnace slag as a precursor for AAM concrete (to get alkali-activated slag – AAS), at first sight, might be considered an efficient mitigation strategy. At this point three possible situations can occur in terms of expansion due to ASR: (1) slight (neglectable) expansion, (2) not neglectable expansion (but lower than in PC), and (3) remarkable expansion (higher than in PC). Looking into the existing literature, the ASR expansion may belong to one of the above-mentioned cases due to the influence of the following parameters: type of aggregate and its composition, type and composition of the ground granulated furnace slag, type and content of activators and their silicate moduli.

In the case of AAS combined with greywacke aggregate and activated by either sodium silicate (SS) or sodium metasilicate (MET) with silicate moduli (Ms) of 1.65 and 1, respectively, Al-Otaibi [337] observed neglectable/slight expansion after 1-year measurements. Neglectable/slight expansion was also observed by Wang et al. in activated slag/metakaolin mixtures (mass ratio of 7/3) with solutions of water glass mixed with NaOH. In this case the sand used was a mixture of quartz glass (as reactive aggregate) and standard sand (as non-reactive aggregate). Mesto [338] investigated AAS made of two different kind of granulated blast furnace slag, RRGR and OVGR, activated at three different sodium concentration; and opal, at different mass percentages, as aggregate. Only a specific combination of opal, slag type and sodium concentration (15%, RRGF and 2.4%, respectively) showed not neglectable expansion (but lower than in PC). Remarkable expansion (higher than in PC) was observed by Bakharev et al. [339] who investigated AAS blended with 2% gypsum and activated with a sodium silicate-sodium hydroxide solution having silicate modulus of 0.75. The authors measured a 0.04% expansion in AAS concrete after 2 months and 0.025% was not exceeded in PC concrete after 12 months. Given these divergent results, the use of ground granulated furnace slag as a mitigation measure for ASR is not always successful and needs for more careful consideration with the other mixture parameters.

In contrast to alkali-activated slag, the literature shows more stable findings for systems with lower amounts of calcium, such as fly ash and metakaolin systems, involving neglectable expansion even with very reactive aggregates. Fernández-Jiménez et al. [340] investigated the ASR expansion of alkali-activated fly ash (AAFA) mortar made of type F fly ashes activated through NaOH or a mixture of NaOH and sodium silicate and a mixture of 90% non-reactive sand and 10% opal sand. The observed ASR expansion of the AAFA was less than 0.1% after 16 days while the PC reference reached an expansion value higher than 0.2% for the same reference time. Similar good performance is reported by Li et al [341][342] for metakaolin systems.

## 5 CONSIDERATIONS FOR CONCRETE PRACTICE AND STRUCTURAL CONCRETE

### 5.1 Introduction

When implementing AAM in industrial scale concrete plants, the robustness in terms of concrete mix design becomes of large importance. This mix design robustness refers to the capacity of the mixture to retain its abilities (e.g., workability, segregation resistance, strength development, durability etc.) despite small variations in the mix properties, mixing method and environmental influences (e.g. non-controlled temperature in the concrete plant), which is a basic requirement for production of concrete on a large scale. Certain types of concrete mixtures, such as self-compacting concrete have by default a lower robustness, due to the more complex mix design compared to vibrated concrete. In this chapter ([Section 5.2](#)) a reflection is made on the mix design robustness of AAM concrete, amongst other based on lessons learned during the URBCON pilot projects conducted ([Chapter 9](#)).

Furthermore, when implementing AAM concrete in practice, often structural applications are targeted that require to combine the concrete with (embedded) reinforcement. Generally used are (steel) reinforcing bars to make reinforced concrete (RC), pre- or post-tensioned tendons to make prestressed concrete, or mixed-in short fibres to make fibre reinforced concrete (FRC). These reinforcement solutions are equally applicable to PC and AAM concrete. In case of AAM concrete structural applications, practicing engineers might raise questions on the applicability of design models, such as defined in Eurocode 2: Design of concrete structures. During the URBCON and DuRSAAM EU-projects, load tests up to failure, as well as proof loading tests on pilot applications, have demonstrated acceptable behaviour of load bearing members applying reinforced AAM concrete that were designed according to Eurocode 2. Though design codes such as Eurocode 2 have not been originally conceived having AAM concrete in mind, the use of such codes in reference to reinforced AAM concrete is not prohibited. Their applicability for the case of reinforced AAM concrete remains however undefined, so that it is highly recommended that design calculations according to Eurocode 2 (or similar codes) are accompanied by the engineering judgement of an experienced design team. The applicability of AAM concrete for rebar reinforced concrete ([Section 5.3](#)), as well as fibre reinforced concrete ([Section 5.4](#)), is addressed in this chapter.

Next to the application of AAM concrete for new built structures, the built environment contains many loadbearing structures that have become deficit over the years and are in need for repair and strengthening. In view of rehabilitation of existing structures, (1) AAM can be used as concrete repair mortar to replace damaged concrete, and (2) textile reinforced AAM mortar can be used to strengthen concrete and masonry load bearing members. This is further discussed in [Section 5.5](#) of this chapter.

## 5.2 Mix design robustness

Industrial conditions are far less controlled compared to laboratory conditions, and these differences seem to have a particular effect on the performance of alkali-activated mixtures. These effects in alkali-activated binders seem more pronounced when using strong alkali salts (e.g., Na-OH and Na-silicate).

### 5.2.1 Laboratory vs. industrial production

In most academic or industrial research laboratories, mix designs and sample production is carried out using one unique batch of raw materials. Aggregates are stored in controlled environmental conditions. Dosing and weighting uncertainties are low and for a given mixing process, most measurements standard deviations are low. Therefore, robustness at the laboratory stage is often a fully ignored feature.

In industry, large volumes of raw materials required for production, mandates the use of different batches of cement, sand, and coarse aggregates, increasing the variation. In addition, storage is only controlled for powders, while sand and aggregates are commonly exposed to all weather conditions. The latter results in varying aggregate water content, but also variation in mixture temperatures. The accuracy in materials weighing is far lower than in the laboratory. Therefore, formulations that seemed fully adequate in terms of laboratory performance, might be difficult to steadily produce daily at an industrial level.

### 5.2.2 Influence of raw materials

Using recycled aggregates can considerably decrease workability of AAM concrete (as has been also discussed in [Section 2.3.3](#)). For example, URBCON partner RPTU tested AAM concrete formulations with natural aggregates (NA), recycled concrete aggregates (RCA) type 1 and type 2 according to [Table 2-3](#). Results are shown in [Figure 5-1](#) and [Figure 5-2](#). In both figures, the notation Mix 1 and Mix 2 refers to 2 different alkali-activated binder formulation, whereas the notation NA and RA refers to the applied aggregate type, respectively. Both mixes have W/B ratio of 0.44 and activator content of 8% with respect to precursor content. The activators included a mix of sodium hydroxide, potassium silicate and sodium silicate for both mixes, however, the percentages of them were different.

[Figure 5-1](#) shows that replacement of natural coarse aggregates with recycled concrete aggregates has a big influence on workability reduction of concretes. This is especially the case for mixtures with higher slump. Replacement of coarse aggregates with recycled aggregate type 2 showed even better workability performance than concrete mixture made by natural aggregates after 10 minutes, while a considerable drop in workability after 45 minutes can be observed. This behaviour could be due to the higher latent water absorption of brick granulates in recycled aggregates type 2. Note however that the presented results are applicable to the applied mixing procedures and results might differ or can be optimize e.g., applying water to compensate for the initial water uptake of recycled aggregates. Replacement of natural coarse aggregates with RCA type 1 did not show a considerable change in compressive strength of alkali activated GGBS concrete ([Figure 5-2](#)). Nevertheless, substitution by recycled aggregates type 2 decreased the compressive strength of concrete by approximately 40% ([Figure 5-2](#)).

### 5.2.3 Influence of temperature

The influence of temperature on the properties of traditional concrete is well known. Increasing the temperature of concrete results in higher early strength, however the strength increase is limited as time goes on. The opposite is true as well: low temperatures cause a decrease in early strength, but a general increase in later strength development. Fresh properties are also affected by temperature:

workability and setting time decreases with increasing temperatures. For this reasoning most concrete producers in West-Europe apply different mix designs in winter and summer time: "fast" cements in winter and "slow" cements in summer.

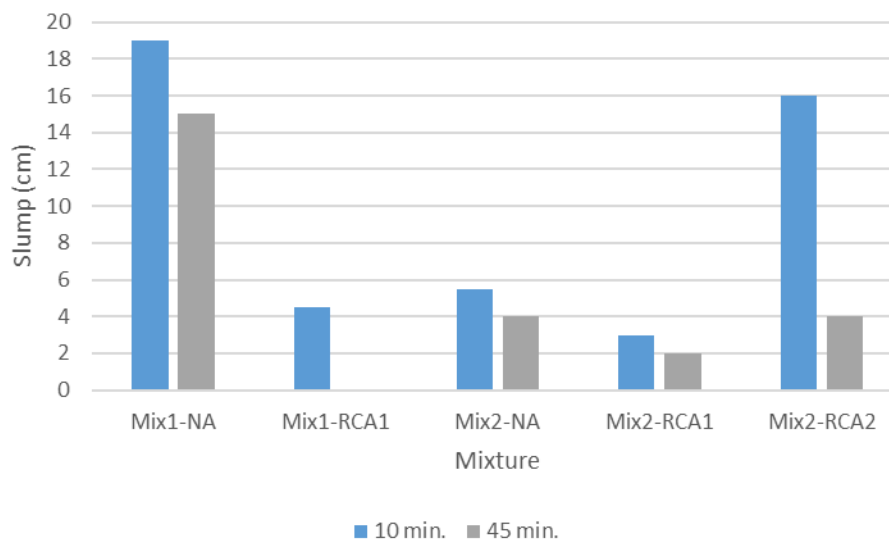

Figure 5-1 Slump of Mix1 and Mix2 with normal coarse aggregates (NA) and recycled concrete aggregates type 1 (RCA1) and type 2 (RCA2) after 10 and 45 min

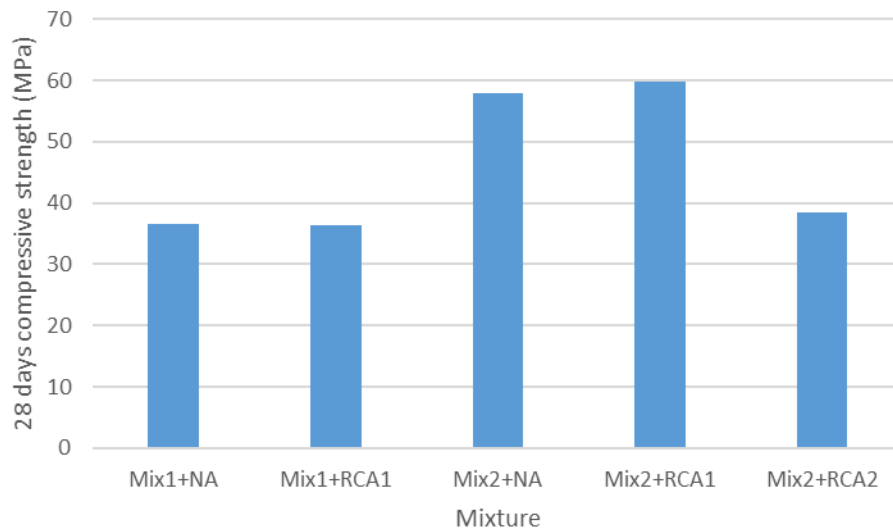

Figure 5-2 Compressive strength of Mix1 and Mix2 with normal coarse aggregates (NA) and recycled aggregates type 1 (RCA1) and type 2 (RCA2) after 28 days

Apart from the heat generated by the hydration reaction, the temperature of the concrete mixture is also influenced by the temperature of the raw materials, the ambient temperature and the heat generated by friction because of mixing. The temperature of the aggregates and water are most important, because of their relative high content.

As such temperature effects on AAM concrete is subject to similar effects as known from PC concrete. Nevertheless, the influence of temperature in alkali-activated binders seems most pronounced when using stronger alkali salts.



### 5.2.3.1 Influence of temperature at laboratory conditions

To study the influence of temperature on laboratory scale, a silicate activated URBCON mixture (as studied by partner UGent) was tested at different temperatures. Concrete mixtures were made at temperatures of 8 °C, 20 °C and 30 °C, as follows. The room where the concretes were produced was at about 20 °C, while the liquid activator was placed in climate rooms for the pre-defined temperatures at least 24 h in advance and the solid materials were kept at room temperature. After casting the concrete was cured at the pre-defined temperatures for 24 hours, after which the samples were cured at 20 °C. The following concrete temperatures were recorded after mixing: MIX 1 (RT) = 19 °C, MIX 2 (30°C) = 24 °C, MIX 3 (8°C) = 16.7 °C.

Slump measurements were taken at 10, 25 and 60 min after mixing and the compressive strength were measured at 1, 7 and 28 days and the results are reported in Figure 5-3 and Figure 5-4, respectively.

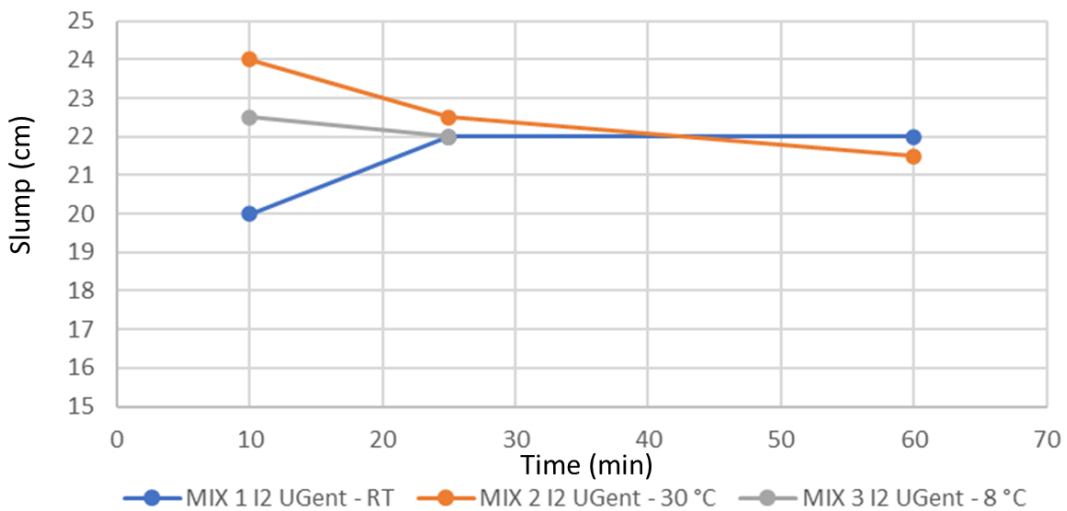

Figure 5-3 Slump of MIX1, MIX2 and MIX3 after 10, 25 and 60 min after mixing

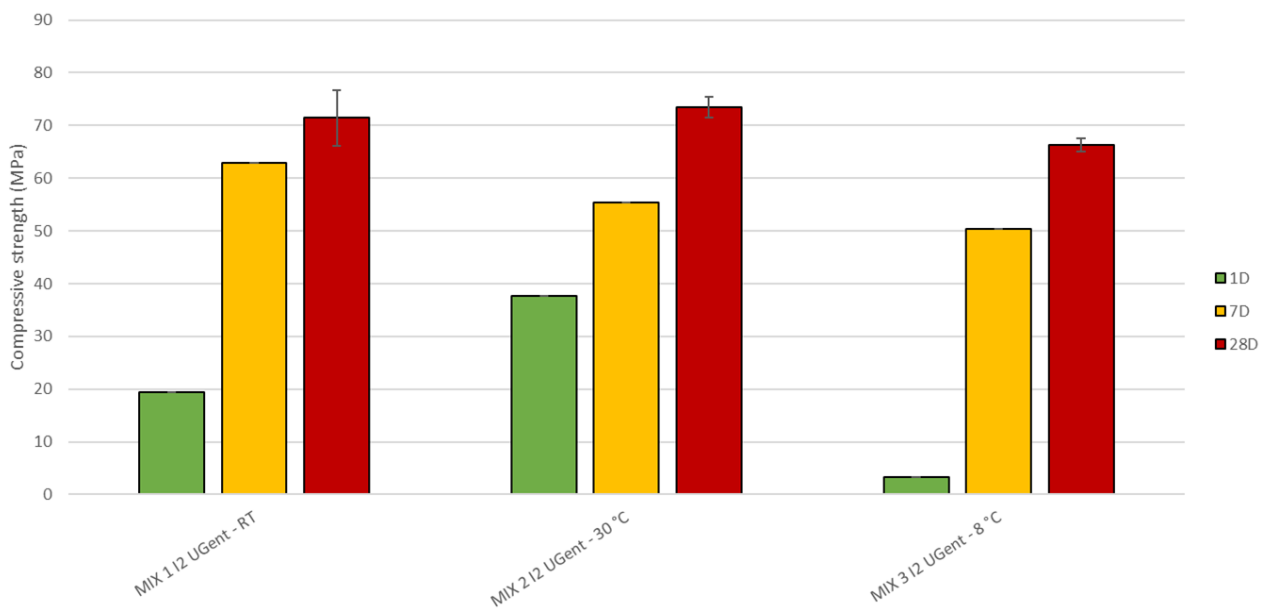

Figure 5-4 Compressive strength of MIX1, MIX2 and MIX3 after 1, 7 and 28 days

The liquid activator temperature did not have a significant influence on the workability retention during the measured period, though the initial slump was somewhat influenced (considering the range of fresh concrete temperature right after mixing between 17°C and 24°C). Furthermore, it was observed that the early properties were affected by the influence of curing temperature set during the first 24h of curing. The 1-day strength was 100% higher for 30°C and 84% lower for 8 °C. At later curing ages, differences in compressive strength remained limited. In precast factories, where 1d compressive strength is significant, adapted AAM mix design might need to be applied in due consideration of ‘summer’ or ‘winter’ working temperature conditions.

### 5.2.3.2 Influence of temperature at industrial conditions

The influence of temperature was also clearly noted at the concrete plant. Here, ambient temperature is much less conditioned compared to laboratory conditions. The same mixture as described above was made at 2 different days, with temperatures in the factory of respectively 15°C and 21°C, which resulted in a compressive strength after one day of 6 MPa and 23 MPa, respectively. These results are in line with those in [Section 5.2.3.1](#).

### 5.2.4 Risk for rapid setting at industrial production

Further to the influence of temperature on the setting behaviour, the question can be raised if other production constrains can result in rapid (or in worst case even flash) setting. During the URBCON project, in one of the production trials at the concrete plant, rapid setting occurred after already 20 min. Concrete temperature and slump flow was in line with previous testing and was considered unlikely to cause this rapid setting. Two possible causes were considered for this rapid setting: (1) residual cement inside the mixer, which is known to cause flash sets in silicate activated systems; and/or (2) the quality and hence the reactivity of the GGBFS, which was from another delivery (variability between ‘old’ vs. ‘new’ delivered batch).

## 5.3 Dimensioning of load bearing elements using AAM concrete

### 5.3.1 Basis for design and dimensioning

EN 1992-1-1: Design of concrete structures (EuroCode 2) is the governing document for the design of load bearing elements (Figure 5-5). In reference to a specific AAM concrete mix, material properties should be initially tested to determine its characteristic values, i.e., compressive strength, flexural strength, modulus of elasticity, etc.

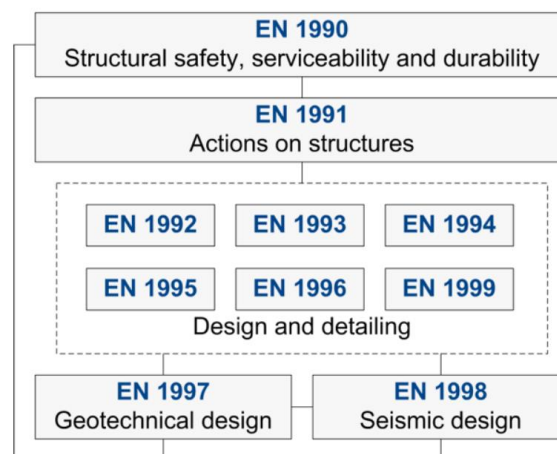

Figure 5-5 Links between Eurocodes [343]

For the design and dimensioning of concrete elements, the appropriate limit states should be considered, such as the ultimate limit state (ULS) and the serviceability limit state (SLS). The latter refers to stress, crack width and deflection limitations, whereby it is important to consider an appropriate value for the modulus of elasticity of AAM concrete (that might be somewhat lower than PC concrete), as well as long-term effects associated with the creep and shrinkage of AAM concrete (that might be somewhat higher than PC concrete). Further, precast elements should be designed for loads during lifting and transportation, whereby it is important to consider early age strength development of AAM concrete (that is influenced by the temperature in the concrete plant, as discussed in the previous section).

### 5.3.2 AAM concrete properties to be tested as input for the design

As an example, typical properties and their test protocols, relevant to the design of structures with AAM concrete are given in [Table 5-1](#) (as decided by one of the design teams of the URBCON pilots). In case readily available AAM mixtures are used, that are well documented, already established values for the main properties needed for the design can be adopted. In case of more novel AAM mixtures or in the framework of quality control, testing of the properties (or a selection thereof as agreed upon by the design team) will typically be needed. [Table 5-1](#) is exemplary and might be adapted by the design and engineering team, depending on the specific building project at hand.

*Table 5-1 AAM concrete properties needed for design and test protocols*

No	Test	Guidelines
1	Compressive strength	NEN-EN 12390-3 Testing hardened concrete compressive strength of test specimens
2	Tensile strength (splitting and/or flexural tensile test)	NEN-EN 12390-5 Flexural strength of test specimens NEN-EN 12390-6 Tensile splitting strength of concrete
3	Density	NEN-EN 12390-7 Density of hardened concrete
4	Porosity (absorption test)	CPC 113-Absorption under vacuum
5	Thermal expansion	TI-B 101 (94) Test Method Expansion Coefficient of Concrete
6	Shrinking	NEN-EN 12390-16 Determination of the shrinkage of concrete
7	Creep	NEN-EN 12390-17 Determination of creep of concrete in compression
8	Frost-thaw resistance	NEN-EN 12390-9 Freeze-thaw resistance with de-icing salts-Scaling
9	Chloride penetration / rapid Cl test	NT Build 492 concrete, mortar and cement-based repair materials: chloride migration coefficient from non-steady-state migration experiments
10	Carbonation	NEN-EN 12390-12 Determination of the carbonation resistance of concrete - Accelerated carbonation method
11	E-Modulus	NEN-EN 12390-13 Determination of secant modulus of elasticity in compression
12	Shear modulus G	Test by NEBEST
13	Poisson's ratio	NEN-EN 12390-13 Determination of secant modulus of elasticity in compression
14	Flow test/setting time	NEN-EN 12350-5 Flow table test
15	Pull out test with rebar	NEN-EN 10080 Steel for the reinforcement of concrete - Weldable reinforcing steel - General

Various AAM mix design have already been developed and several companies offer commercial ready mix AAM concrete. Nevertheless, most of these concretes are not (yet) certified by an independent body, so that testing of properties becomes of importance to take at hand by the design team. In the meantime, certified AAM concrete is emerging in Europa, among which through the establishment of an ETA (European Technical Approval) scheme currently under development.

### 5.3.3 Design check list for AAM concrete applications

Like in any building project and for any type of concrete used, minimum requirements should be maintained when designing concrete load bearing members or similar products. An example is given in Table 5-2, as has been applied in the framework of the URBCON pilots (Chapter 9). Depending on the region, the corresponding national annexes should also be referred.

*Table 5-2 Example of design requirements applied in URBCON pilots*

Design requirements	Specification
- Design life	EN 1992-1-1 Table 4.4N
- Consequence class	EN 1990-1-1
- Minimum material properties of concrete	EN 1992-1-1 Table 3.1
- Environmental class Crack width: $W_{max}$ (visual requirement)	EN 1991-1-1 Table 4.4N/ Table 7.1 N
- Covering of concrete	EN 1992-1-1 Table 4.4N
- Maximum rebar requirement	EN 1992-1-1 Cl 9.2.2.2 (3)
- Maximum rebar requirement	EN 1992-1-1 Cl 9.2.1.1 (1)
- Minimum distribution rebar requirement	EN 1992-1-1 Cl 9.5.2
- Deflection control: Allowable deflection	EN-1992-1-1 Cl 7.4.1 (4)
- Lifting/ transportation and placement	As per the recommended guidelines

### 5.3.4 Design by testing through proof load testing up to failure

In the framework of the envisaged pilots making use of reinforced concrete, structural load testing up to failure has been conducted on slabs with a width of 400 mm, a height of 150 mm and a span length of 3 m (slab total length of 3,2 m). The slabs were reinforced with 4 longitudinal steel rebars diameter 8 mm (for flexural tests) or 12 mm (for shear tests) and lateral rebars diameter 6 mm each 400 mm. Slabs were produced with 3 types of AAM concrete as developed by URBCON project partners, in comparison to a reference slab in PC-based concrete. Slabs have been tested for both flexural load carrying capacity and shear load carrying capacity. This load testing provided valuable upfront information to the design engineering teams of the URBCON pilots conducted. Preceding the slab tests, also some rebar bond pull-out test has been performed to verify bond interaction between steel rebars and AAM concrete. These pull-out tests confirmed proper bond strength when combining deformed steel rebars with AAM concrete.

The test set-up used for testing of the slabs is illustrated in Figure 5-6. The obtained test results in terms of load-deflection response, cracking and failure aspect is given in Figure 5-7 till Figure 5-10.

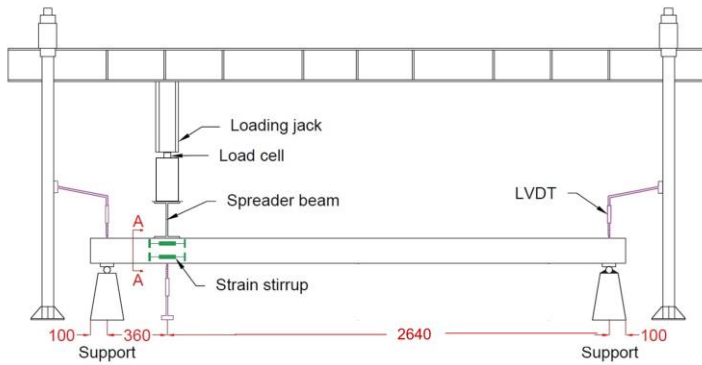
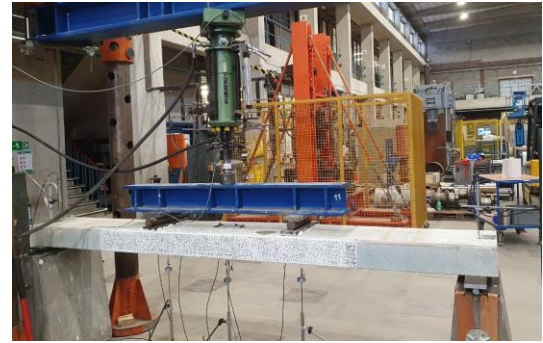
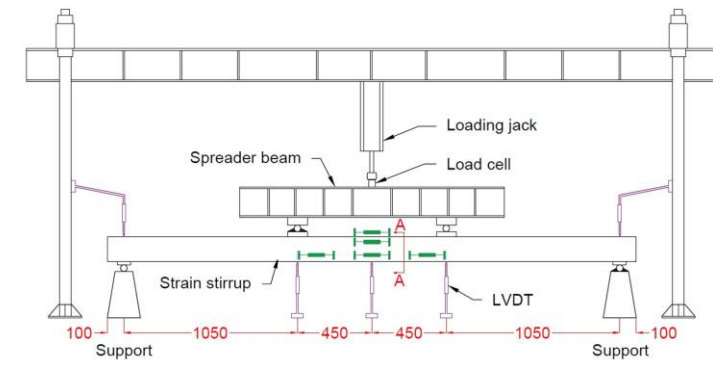

Figure 5-6 Test set-up (dimension in mm, not on scale) of flexural load tests (top) and shear load tests (bottom)

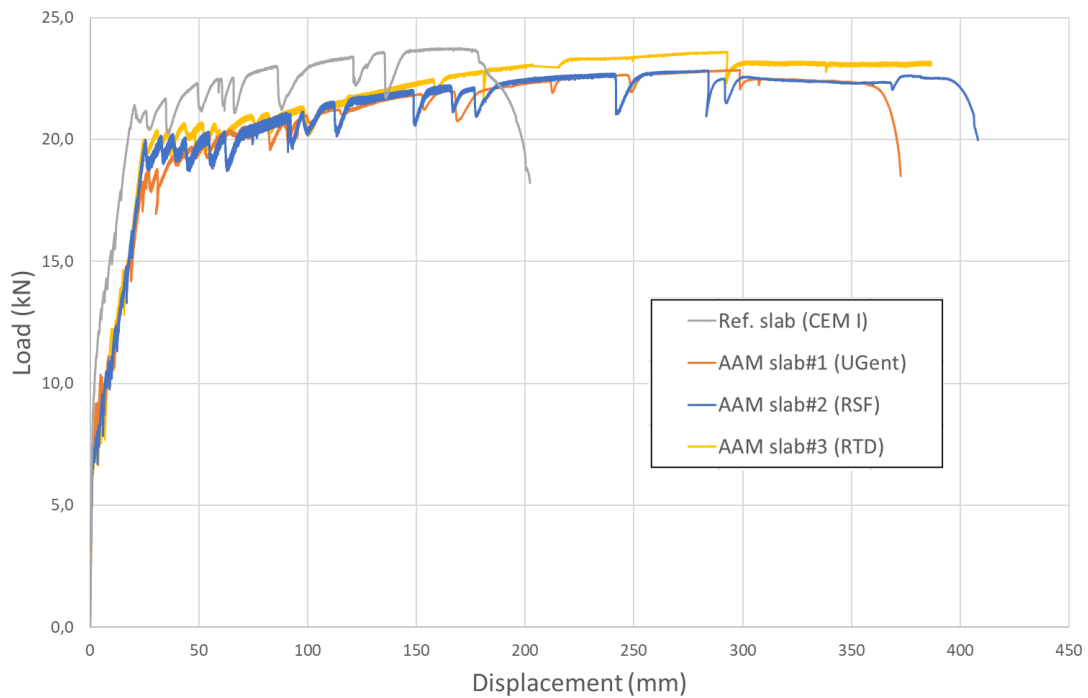

Figure 5-7 Flexural tests on slabs: load-deflection response



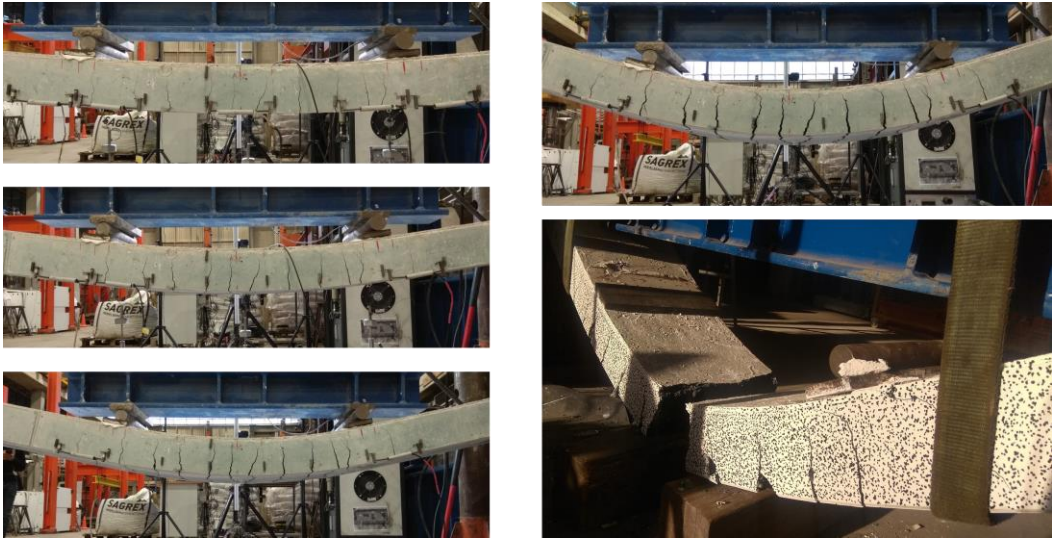

Figure 5-8 Flexural tests on slabs: observed crack development and slab failure

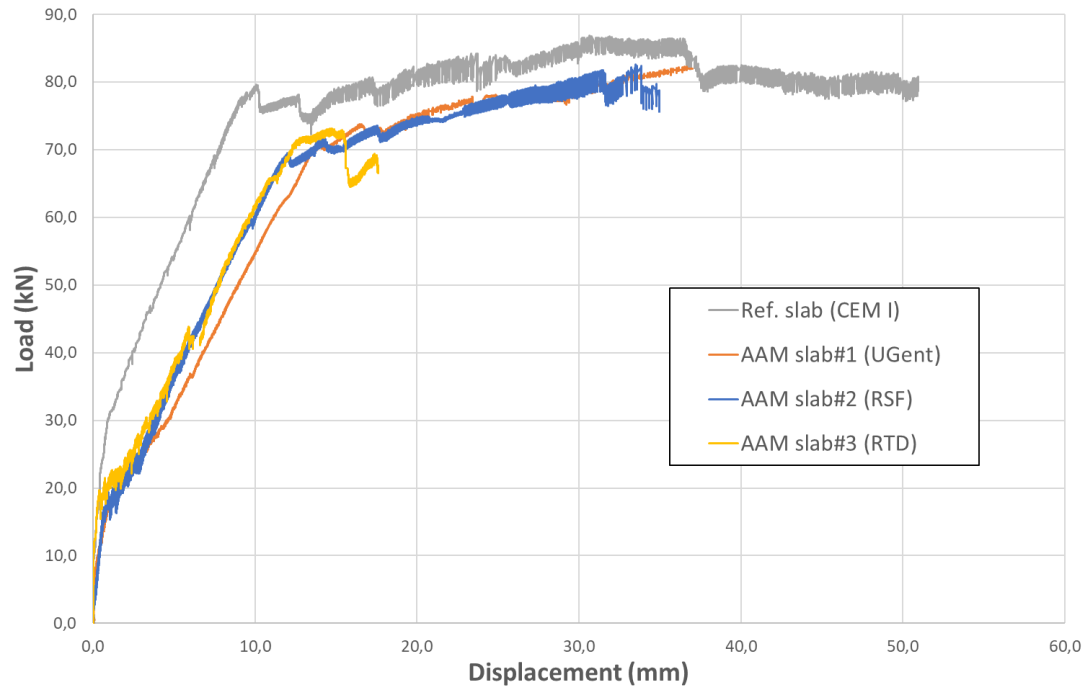

Figure 5-9 Shear tests on slabs: load-deflection response



Figure 5-10 Shear tests on slabs: observed critical shear crack at failure



The obtained test results show very similar behaviour between the reference slab and the slabs in AAM concrete. The failure load and failure aspect were almost the same amongst the different slabs and clearly illustrated the feasibility to use AAM concrete in load bearing reinforced concrete slabs.

In terms of load-deflection behaviour of the slabs in flexure, it is noted that the first cracking load of the AAM slabs was somewhat lower, resulting in slightly higher deflections for a given load. This can be easily accounted for in the design by considering proper values (such as determined from standard quality control tests on the AAM concrete) for the tensile strength and modulus of elasticity of the AAM concrete. The predicted flexural capacity (through straightforward moment equilibrium considerations) of the slabs corresponded well with the obtained test results, indicating applicability of flexural design approaches also for the ultimate limit state. Slabs failed by yielding of the steel followed by concrete crushing. In terms of deflections of the slabs at ultimate generally somewhat higher deformability has been observed for the AAM slabs.

For the slabs tested in shear (with a shear span over effective depth of about 2,5), it was observed that all slabs reached yielding of the longitudinal steel, with flexural cracks that opened under the applied point load. As load increased eventually shear cracking increased, and a critical shear crack was formed leading to failure of the slab. The shear capacity of all the tested slabs was similar and exceeded the predicted shear capacity of the concrete slab (Eurocode 2 shear capacity of members without additional shear reinforcement).

## 5.4 Fibre reinforced alkali-activated concrete

### 5.4.1 Reducing the brittleness of plain concrete

Although alkali-activated concrete (AAC) has been reported to be as effective as Portland cement concrete (PCC) in terms of mechanical and durability performance, likewise, it also shows brittle behaviour [344][345], i.e. the tendency of the material to fracture abruptly under tension before significant irreversible deformation occurs. A common method to reduce brittleness of plain concrete is the addition of fibre reinforcement in the matrix, improving cracking resistance, toughness, and ductility of the plain matrix [344]. Due to shrinkage and thermal deformations, micro-cracks pre-exist within the concrete, even before stresses are applied. When a uniaxial tension is applied, micro-cracks begin to form, initially at the interface between the cement paste and the aggregates and propagate in an unstable manner until crack localisation occurs. In plain concrete, only aggregates are responsible for crack bridging and branching (Figure 5-11). In fibre reinforced concrete, a combined bridging action of aggregates and fibres provides stress transmission within the composite, improving its fracture energy and toughness (Figure 5-11). Fibre type, geometry, aspect ratio, volume fraction, orientation, distribution, and fibre-matrix interaction directly influence the effect of fibre incorporation on the composite performance.

As the incorporation of fibres has no significant effect on the compressive strength of the composite up to a content of 1% by volume, the strength classification for plain concrete can be used also for FRC [346]. Although fibres mainly influence the residual post-cracking tensile strength, the large number of parameters affecting the fibre pull-out mechanism does not allow reliable prediction of FRC uniaxial tensile response based on the matrix, fibre properties and dosage [346]. Bending tests according to EN 14651 are performed to evaluate the post-cracking tensile strength of the composite and classify it based on specific values obtained from the load-CMOD (crack mouth opening displacement) diagrams, corresponding to the material behaviour at the serviceability limit state (SLS –  $CMOD_1 = 0.5$  mm) and ultimate limit state (ULS –  $CMOD_3 = 2.5$  mm).

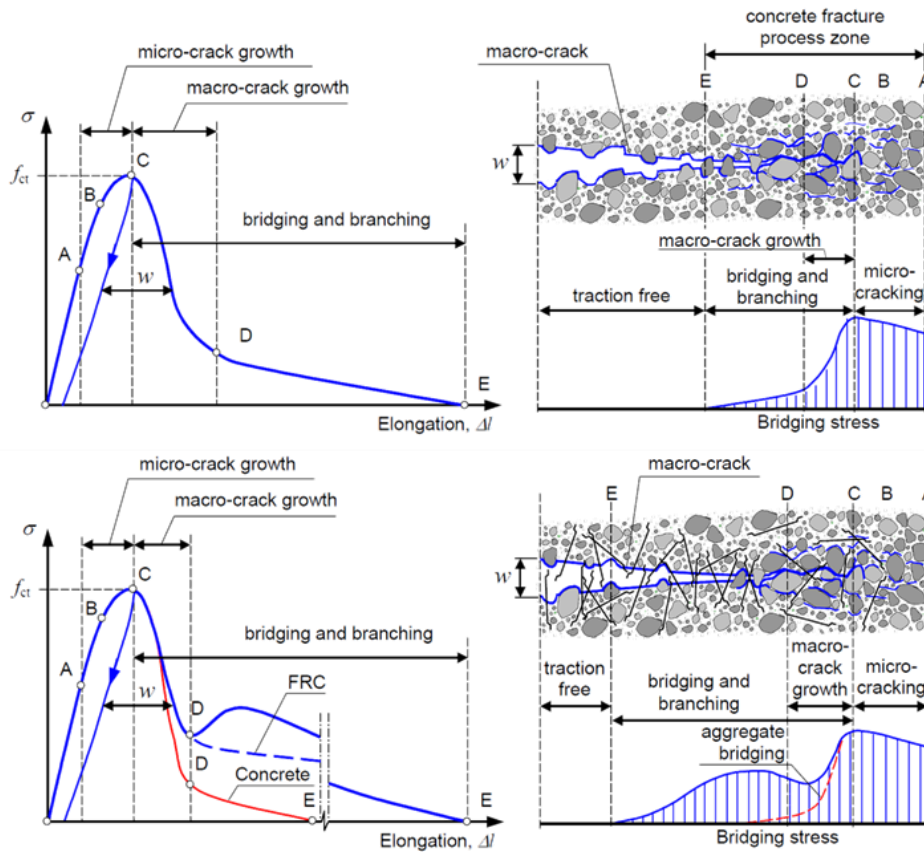

Figure 5-11 Crack propagation and related stress-strain curve in plain and fibre-reinforced [347]

#### 5.4.2 Fibre reinforced alkali-activated concrete (FRAAC)

The same characterisation testing EN 14651 can be applied to evaluate the performance of fibre reinforced AAC (FRAAC). As for fibre-reinforced PCC (FRPCC), the physical, chemical, and mechanical properties of the fibres as well their dosage have a significant impact on the performance of FRAAC. However, the performance of FRAACs is also influenced by several key parameters in the formulation of the mix design; namely, binder type and chemical composition, alkaline solution/solid ratio, and curing conditions, which need to be considered and modified, if necessary, when fibres are added to the material. Several investigations demonstrated that good dispersion of the fibres, regardless of the fibre type, ensures good fibre-matrix interaction in AACs. The tensile strength of fibre-reinforced alkali-activated concrete is higher than that of FRPCC, especially when silica fume is added [345]. Although fibres used as reinforcement in PCC range from natural to synthetic, the most used ones in FRAACs are steel and PVA fibres [344]. Although the incorporation of fibres in AACs improves the flexural and tensile properties, it is necessary to evaluate the optimum dosage for each type of fibre and matrix investigated, as workability and mechanical properties are directly related to the fibre type and content [348].

König et al. [349] investigated the effect of the incorporation of steel fibres and macro-PP fibres on the compressive, splitting, and flexural strengths of PC, fly ash-based and slag-based alkali-activated concrete. The incorporation of fibres, regardless of the fibre and matrix type, had no significant effect on the compressive and splitting tensile strengths, as a positive effect of fibres addition on these properties can be expected with high short fibres contents, as they can be activated by micro-cracks before failure. However, as shown in Figure 5-12, the effect of steel and macro-PP fibres on the residual flexural strength varies depending on the matrix type.

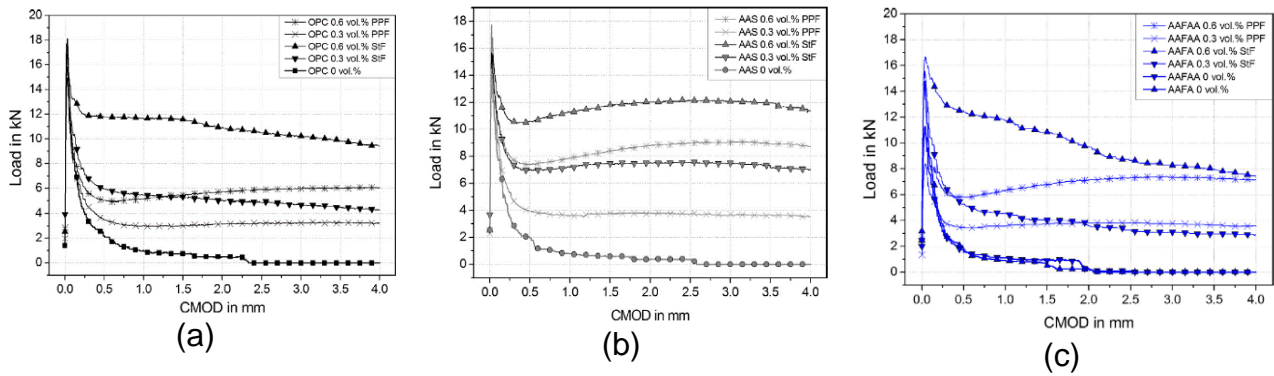

Figure 5-12 Load-CMOD relationships for PC (a), slag-based (b) and fly-ash-based (c) AAC, reinforced with steel and macro-PP fibres [349]

Although the best behaviour is achieved with steel fibres at the highest volume fraction (0.6% vol.), regardless of the matrix type, the addition of steel fibres improves the post-cracking behaviour in alkali-activated slag-based concrete compared to PCC and fly-ash AAC, resulting in higher residual flexural strength at higher CMOD values. The better behaviour of slag based AAC can be explained by the superior bond between fibre and matrix [345]. Fly-ash based alkali-activated concrete performs similarly to PCC but has a lower peak load (and related flexural strength), due to the lower compressive strength of the composite. In the case of macro-PP fibres, slag-based alkali-activated concrete outperforms traditional concrete in terms of post-cracking flexural behaviour. This study is just one of the available examples of how alkali-activated concrete can outperform traditional concrete when reinforced with the same fibre type in the same volume fraction.

#### 5.4.3 Fibre reinforced high-performance alkali-activated concrete (FRHPAAC)

The addition of fibres in traditional concrete, either in form of continuous aligned fibres or randomly oriented short fibres, is the most widely used and efficient method to minimise and arrest crack propagation, improving the toughness and tensile strain capacities of brittle matrices, thereby avoiding sudden failures under tensile loading. Depending on the fibre type and content, the tensile response of the composite can vary from brittle (plain concrete) to quasi-brittle (post-cracking tension softening behaviour typical of FRC, with limited fibre volume fraction) to ductile (post-cracking strain-hardening behaviour typical of high-performance fibre-reinforced concrete composites (HPFRCC)).

The different tensile responses of FRC and HPFRCC are characterised by different fracture mechanisms, as shown in Figure 5-13. FRC generally exhibits post-cracking (post-peak) softening behaviour, which is caused by the formation and propagation of a localised single macro-crack; HPFRCC shows commonly post-cracking hardening behaviour, as multiple micro-cracks form and the fibre bridging effect increases the load-bearing capacity and ductility of the composite [350]. Advances in HPFRCC technology over the last decade have resulted in the development of the so-called ECC (Engineering Cementitious Composite), high-performance fibre-reinforced composites showing moderate tensile strength (4-6 MPa) but high ductility (3%-5%) [350]. The characteristic strain-hardening behaviour of ECC has recently been achieved also with alkali-activated matrices. These Engineered Geopolymer Composites (EGCs) show high deflection capacity and strain-hardening behaviour in uniaxial tension [353]. As for engineered cement-based composites, an essential requirement for strain-hardening behaviour is multiple steady-state micro-cracking formation and propagation. The micro-crack initiated from a defect site (voids or micro-scale heterogeneities) must propagate in a flat crack mode (Figure 5-14), in which the crack opening

remains constant under loading due to fibre bridging action. Additional loading leads to the formation of another micro-crack from another defect site and flat crack extension. This multiple micro-cracking mechanism leads to the strain-hardening of the composite.

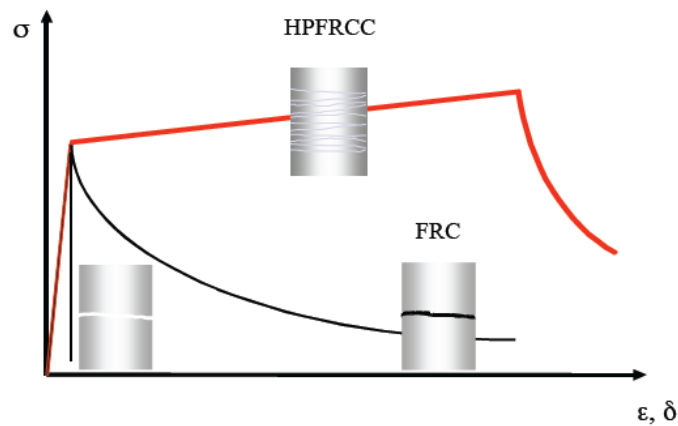

Figure 5-13 Tensile response of normal concrete, fibre-reinforced concrete (FRC) and high-performance fibre-reinforced cementitious composites (HPFRCC) under uniaxial tension [350]

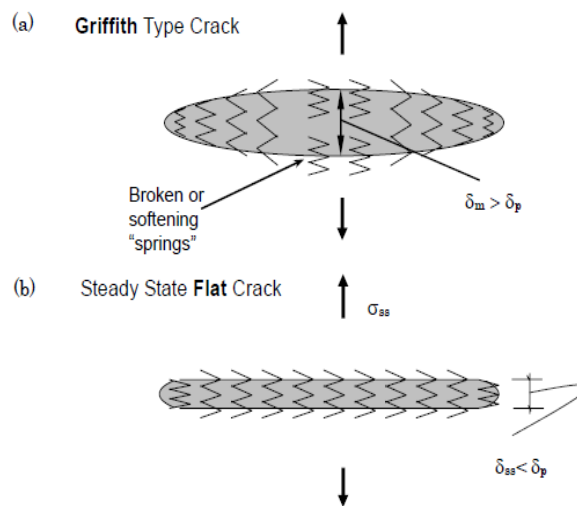

Figure 5-14 Steady state crack analysis [351]

Micromechanics-based design models for strain-hardening behaviour developed for ECCs link the composite properties to the material microstructure, tailoring the material constituents and optimising the mix design. The micromechanical parameters related to the fibre include length, diameter, elastic modulus, tensile strength, and volume fraction; matrix-related parameters are matrix fracture toughness and elastic modulus. The fibre-matrix interface depends on frictional and chemical bond strength [352]. Based on these parameters, the micromechanics-based model can predict the micromechanical properties and link them with the composite performance. The micromechanics principles developed for ECC also apply to EGC, however, several parameters need additional attention in the mix design optimisation [354]:

- Water to geopolymer solids ratio. An increase in W/GP solids (from 0.20 to 0.23) results in a considerable decrease in both compressive strength and elastic modulus of the matrix.
- Sand size and content. The addition of sand, regardless of the size and content, increases the compressive strength and elastic modulus. However, the sand content (sand/binder ratio) must be accurately designed and limited to achieve the tensile ductility of the composite.

As for traditional cement-based concrete, the compressive strength is not significantly affected by the addition of fibres: the progressive increase in fibre content does not always correspond to an increase in compressive strength. Different factors, such as fibre type and geometry, fibre volume fraction, matrix characteristic, mixing and curing conditions, vibration time and frequency can affect the density, the compaction, and the air content of the hardened concrete, and consequently also the compressive strength at an early and late age. A more significant effect of the addition of fibres is visible in the flexural strength and the post-cracking behaviour of the composite. Depending on the fibre type, volume fraction, distribution and orientation, the flexural strength and the post-cracking behaviour increase with the increase of fibre content [355].

EGCs exhibit strain-hardening behaviour, regardless of their W/GP solids, sand size and content [353]. As for ECCs, the addition of hydrophilic PVA fibres (2% volume fraction) into the fly ash-based matrix leads to the development of a very strong fibre-matrix interaction, which heavily influences the ultimate strength of the composite. However, the fibre-matrix interfacial properties can vary due to different parameters, such as mix proportion, activator composition and/or concentration, and fibre oil-coating percentage, leading similar systems to achieve different ultimate tensile strength [353]. In addition to PVA fibres, also polyethylene (PE) fibres represent a suitable reinforcement to achieve strain and deflection hardening behaviour in geopolymer composites (with fly ash or fly ash/slag blended as a binder). The available few studies involve the use of heat or water curing and the use of powder activators, reducing the possible application in real in-situ projects. Although ambient air-cured geopolymer composites (fly ash and slag blended as a binder) show strain and deflection hardening with 0.75-1% PE fibres, additional investigations are needed to define the critical volume fraction for PE fibres and to better investigate the bond between the fibre and geopolymer matrix [355].

#### 5.4.4 Considerations toward real-life applications of FRAAC

The isotropic properties of FRC due to the uniform fibres dispersion favour its application in different construction fields, from industrial pavements, tunnel lining and slope stabilisation, to thin shells and dams [356] [357].

Studies related to alkali-activated materials demonstrate that these new binders could not only develop high mechanical performance but also a better resistance to chemical attacks, resulting in promising construction material, especially for harsh environments. However, being these innovative construction materials are relatively new, their application in the concrete engineering field will take time, as different fundamental steps need to be followed:

- Accumulate fundamental and reliable research data results and establish production and construction methods
- Establish the assessment test methods to evaluate the characteristic performances and formulate draft performance-based recommendations for design and construction
- Apply the material carefully beginning with small-scale projects

However, the last point is essential to collect durability data about real-life applications of these construction materials but to build new structures design requirements and regulations (step 2) are needed, which are also based on durability data (obtained in step 3). No design and building regulations mean no real-scale projects; no new constructions mean no durability data essential for design regulations. Applying the material in the construction practice not only helps to collect data about mechanical and durability performance, but also helps to increase the knowledge related to the material producing and casting, allowing improvements in the research itself. This is the fundamental knot to be untied to apply new materials and technological systems in the construction practice.



## 5.5 AAM (textile) mortar to repair and strengthen structures

Most of the contemporary infrastructure is made of concrete and designed for a life span of 50 to 100 years. Only small part is, in fact demolished after that period. Most of the concrete structures reaches the end of service life in a condition more suitable for repair or upgrade than for the replacement. Furthermore, concrete structures often experience various environmental attacks, accidental events, lack of maintenance and other actions, which can result in need for strengthening during their service life. For all these reasons, in recent years, developed countries often are investing more in rehabilitation and repair than in new construction.

Structural repair and maintenance of the existing structures can be a complex engineering endeavour. The need for repair can arise suddenly, for example after incidental events, strengthening must be applied quickly and efficiently. One of the emerging techniques for structural repair of masonry and concrete structures combines fibres, in form of one-dimensional and multidimensional textiles bonded to the structure with inorganic matrices. These systems for strengthening are named fibre reinforced cementitious matrix (FRCM) in United States and Italy, or in German speaking countries textile reinforced concrete (TRC) or textielbeton. In the rest of Europe this material is mostly called textile reinforced mortar (TRM). To ensure proper composite action, only fine aggregate fraction (typically maximum 2 mm) is used in these systems making them strictly speaking mortars and since the inorganic matrix is not exclusively cementitious (can be lime based or alkali-activated) the composite material will further be addressed as TRM. Apart from strengthening purposes, textile-based composites are used in producing lightweight structural and non-structural prefabricated and in-situ elements.

### 5.5.1 Mortars for structural repair and strengthening of concrete structures

#### 5.5.1.1 Alkali-activated repair mortar

Reasons for concrete degradations are often harsh environmental conditions, and the purpose of the repair material is to withstand them after the application, so the entire series of standards EN 1504 prescribes wide range of prerequisites for different applications of concrete repair. EN 1504-3 classifies repair mortars as structural and non-structural and divides them into classes: R1 and R2 are low strength mortars intended for cosmetic repair, whereas R3 and R4 are intended for structural repair and strengthening where load transfer should be considered, R4 with higher load transfer, and R3 with lower durability and lower load transfer. Amongst other, the feasibility of AAM repair mortar has been investigated by [358].

Over the scope of DuRSAAM project slag-based repair mortars have been investigated in the terms of slump and flow retention, flexural, compressive (for sealed and ambient cured (AC) specimens) and pull-off strength. The purpose was to develop alkali-activated repair mortar based on locally available industrial by-products and furthermore to check its potential for structural strengthening of concrete structures by means of AAM-based TRM.

As a precursor for alkali-activated repair mortars, locally available BFS (Ecocem Benelux) is used. Sodium silicate solution (type Crystal 112, with molar ratio of the silicate solution of about 2), sodium hydroxide flakes with purity higher than 99%, and demineralized water are used to create the aqueous alkali solution. The mortars are prepared with an aggregate to precursor ratio of 2.42, water to precursor ratio of 0.45 and Na<sub>2</sub>O content (present in the alkali solution) of 5 % per weight of precursor.



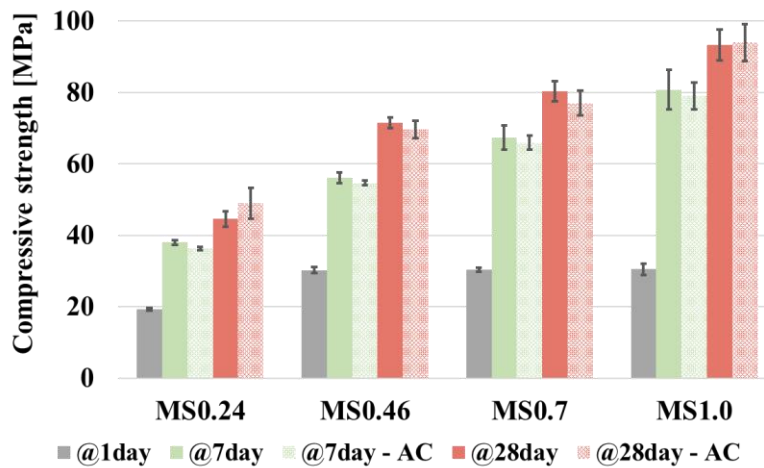

Figure 5-15 Compressive strength development of repair mortar with different molar ratios under pre-defined curing regimes

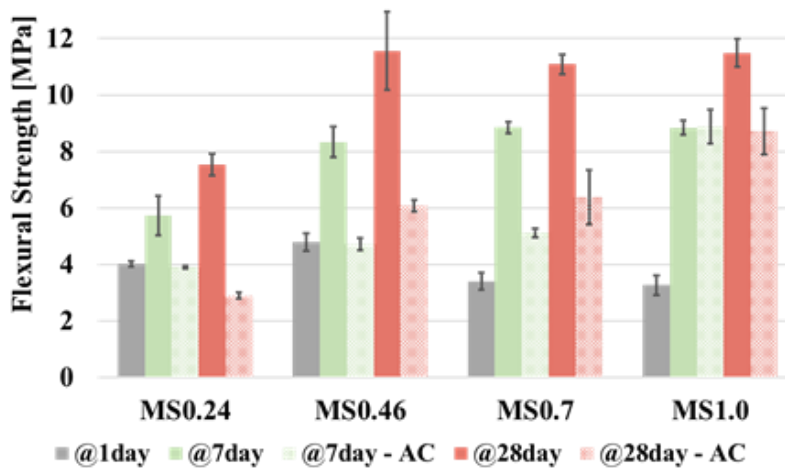

Figure 5-16 Flexural strength development of repair mortar with different molar ratios under pre-defined curing regimes

The molar ratio ( $M_s$ ) of the alkali solution is tailored by blending the sodium silicate and sodium hydroxide, while the concentration of the  $Na_2O$  per weight of the precursor was kept the same. Solutions with  $M_s = 0.24, 0.46, 0.7$  and  $1$  are used as activators. The initial configuration  $M_s = 0.24$  was designed as a stiff, thixotropic trowel grade mortar suitable for application on vertical surfaces (spread after 15 shocks of 160 mm), but with increase of the  $M_s$  ratio the initial flow increased to the value more characteristic to self-compacting mortars (suited for casting) with values of spread after 15 shocks closer to 300mm.

Compressive strength of tested configurations is presented in Figure 5-15. All configurations showed compressive strength above 45 MPa, which is the minimal strength for R4 repair mortars according to EN 1504-3. With the increase of the molar ratio of the silicate solution, compressive strength increases, from about 45 for  $M_s = 0.24$  to around 94 MPa for  $M_s = 1$ . The curing condition does not affect the compressive strength of the mortars, with differences between sealed and ambient cured (AC) specimens within margins of standard deviation. In contrast to this the change in  $M_s$  affects flexural strength in all configurations (Figure 5-16). For high-end structural repair mortars, flexural strength of 8 MPa is required. For the reference mix  $M_s = 0.24$  after 28 days sealed curing, this is

approached with 7.5 MPa. This value was lower than the 11.4 MPa reported in a similar study for the same age and same curing conditions. With increase of the MS, flexural strength of sealed specimens generally increased, but not necessarily already after 1 day. A 28 day flexural strength of 11.5 MPa was obtained for  $M_s = 1$ , for sealed curing. When cured at unsealed ambient conditions, the flexural strength was significantly affected, sometimes with strength reductions of 50% with respect to their sealed counter parts. Only mortar with  $M_s = 1$  achieved value above 8 MPa, while configurations  $M_s = 0.46$  and  $M_s = 0.7$  showed values above 6 MPa (Figure 5-16).

*Table 5-3 Bond strength results of mixes with different silicate molar ratios (0.24, 0.46, 0.7 and 1.0)*

Configuration	MS 0.24	MS 0.46	MS 0.7	MS 1
Adhesive bond strength, mean value [MPa]	2.5	$\geq 2.1$	$\geq 1.7$	$\geq 1.7$
Standard deviation	0.27	0.31	0.30	0.30
Failure mode, cumulative for all tests	80% mortar-concrete interface, 20% concrete	90% concrete, 10% mortar concrete interface	100% concrete	100% concrete

To study the adhesive bond between the repair mortar and a grid blasted concrete substrate, the 4 mixes were tested further. The failure aspect of the specimens is shown in Figure 5-17 and bond strengths results are presented in Table 5-3.

Specimen  $M_s = 0.24$  had no visible cracks or delamination before testing. An average pull-off strength of 2.5 MPa was obtained fulfilling criteria for R4 class mortar from EN 1504-3. It was observed that failure is either on the interface between mortar and concrete or in the substrate itself. This indicates that the bond capacity was close to the tensile strength of the substrate. For higher  $M_s$  results are inconclusive (failure in the concrete substrate, yet the substrate strength was not sufficient to verify the 2.5 MPa criterion). On overall results demonstrated the potential to develop also AAM for repair mortar applications, and work is ongoing to develop more optimized AAM repair mortars with blends of local by-products.



*Figure 5-17 Direct tension bond testing - failure mode aspects*

### 5.5.1.2 Textile-reinforced alkali-activated mortars

Textile reinforced mortar (TRM) combines good aspects of inorganic matrixes and technical textiles. The good chemical and physical compatibility with concrete and masonry substrates (also wet ones), certain level of water permeability and ability to be applied in a simple and traditional way are benefits of inorganic matrixes; while high-strength-to-weight ratio of TRMs, that characterizes fibre meshes, enhances load carrying capacity of strengthened elements without significant increase of weight. Textile reinforced mortar usually has thickness of about 5 to 20 mm. The matrix is reinforced with meshes of continuous high-strength non-corrosive fibres made of carbon, basalt, aramid, glass and polyparaphenylene benzo-bisoxanole (PBO). Also meshes in high strength steel cords are possible. The net distance between the fabric yarns is constrained to up to 30 mm and should typically not exceed two times thickness of the mortar. Composite action of TRMs is facilitated by penetration of the mortar through the openings in textile and mechanical interlocking of the textile in the hardened mortar. Bond between the matrix and the textile can be improved by adding short fibre into the inorganic matrix, coating the textile with epoxy, covering it with silica fume and other ways. However, on the market there are typically uncoated and coated textiles. Uncoated textiles are available e.g. PBO, glass and carbon, they are easy to fold and be applied around the edges, but on the other hand can slip easily through both fresh and hardened mortar which can create eccentricities in the hardened material and stress concentrations. However, the penetration of binding material through dry uncoated fibres can result with an impregnation of dry textiles and thus provide an additional interlocking between the two materials. For achieving the impregnation of dry fibres, the specific flowing and penetrability characteristics of binding materials need to be obtained.

Coated textiles are mostly made of glass, carbon, basalt, and others and have larger net distances between yarns, which facilitates better mechanical interlock between mortar and textile. Coated textiles typically have better dimensional stability and are less prone to local eccentricities which improves stress distribution along textiles and overall efficiency of meshes. Depending on the coating, especially when epoxy coating is applied, they can be very stiff and difficult to apply over edges. These textiles are more suitable for prefabricated elements and retrofitting of large surfaces like floors and walls.

The behaviour of this composite material can be described with a multi-linear stress strain model with three distinct stages – uncracked, multiple cracking and cracking completed (Figure 5-18 and Figure 5-19). Forming of cracks in TRMs is much finer compared to reinforced concrete or masonry elements. Therefore, the tensile load-bearing behaviour is of high significance for the material characterization and is tested through uniaxial quasi-static tensile testing on TRM tensile coupons (typically after 7 days of curing). The tensile tests are carried out in deformation-controlled mode by crosshead displacement at a displacement rate of 0.002 mm/s. The test is terminated after a load loss of at least 70% of the maximal load recorded.

Preparation of TRM coupon specimens for tensile tests is done similar as TRM applications in practice. A first layer of fresh mortar is spread evenly with a thickness from 3 to 5 mm thick, followed by the placing of earlier prepared textile mesh that is then pressed through the fresh mortar with a trowel to enhance the penetration of fresh mortar through the grid opening. This procedure is necessary for obtaining a better adhesion between textile and mortar. For additional layers, the same 'wet-application' procedure is repeated. After applying the desired number of textile layers, the final flat-covering layer of mortar (3-5 mm) is applied.

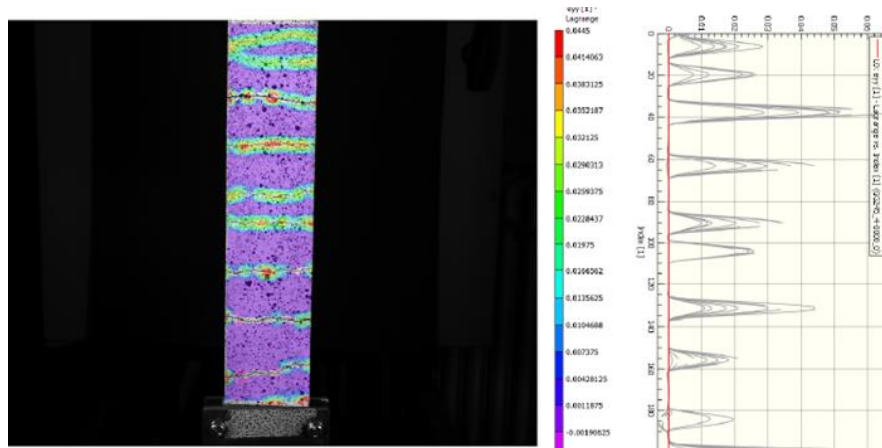

Figure 5-18 Cracking behaviour of AAM TRM tensile coupons

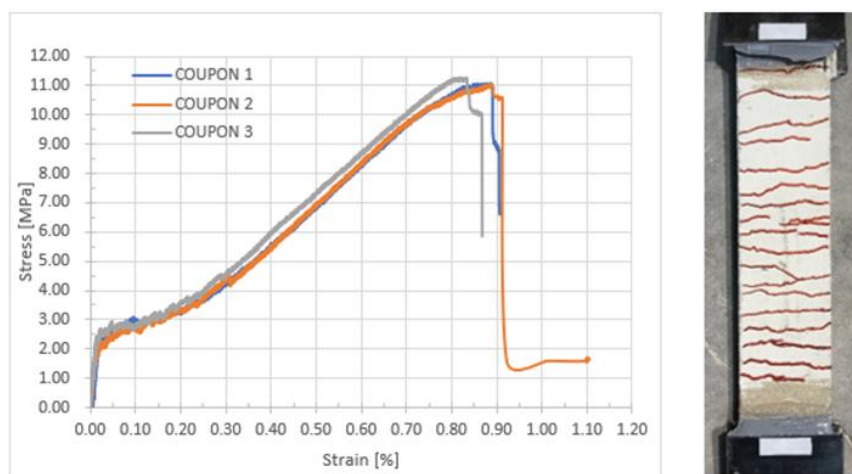

Figure 5-19 Stress-strain behaviour of AAM TRM tensile coupons

The stress-strain diagram, Figure 5-19, shows an optimum adhesion between the uncoated carbon-fibre textile grid and the AAM mortar. Herewith, three zones of deformation development can be easily identified on the stress-strain diagram, fitting the existing TRM model with PC based mortars, perfectly. Red marked lines on the photo (Figure 5-19, right) are illustrating the tensile cracks. Tensile tests showed feasibility of AAM-based TRMs, applying amongst other glass or carbon fibre-based textiles.

### 5.5.2 Retrofitting of stone masonry structures

The effectiveness of AAM-based TRMs as seismic retrofitting material was studied in the DuRSAAM project, amongst other, on masonry wall specimens subjected to cyclic loading. Natural stone walls were made of cut stones and regular building mortar (PC-based) so to represent structural elements of historical residential buildings, particularly present in the Mediterranean. AAM mortar matrix with coated basalt textile (350 g/m<sup>2</sup>) were used as TRM component materials that was applied either as single sided (two layers) jacket (2BF\_AAM) or single-layered jacket applied at each side of the wall (1BF\_AAM\_1BF). Three different testing configurations were used in this study: the slender and squat walls subjected to in-plane cyclic loading and slender walls subjected to out-of-plane cyclic loading. In-plane and out-of-plane cyclic tests (Figure 5-20) have been conducted through two different approaches and setups – 3 point bending cyclic tests for slender walls and shear cyclic tests in case of squat walls.



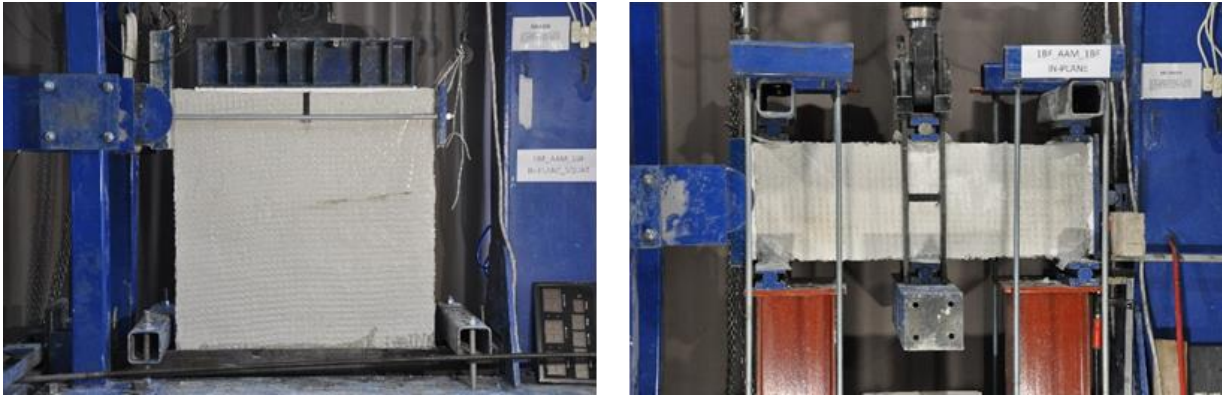

Figure 5-20 Test setups for in-plane tests of squat (left) and slender (right) walls

Three-leaf natural stone masonry walls were successfully subjected to cyclic loading. Some of the recorded outputs are presented in a form of envelope functions of load-displacement hysteretic loops. Figure 5-21 shows hysteretic loop envelopes for squat (a) and slender (b) specimens tested in-plane and specimens tested out-of-plane (c).

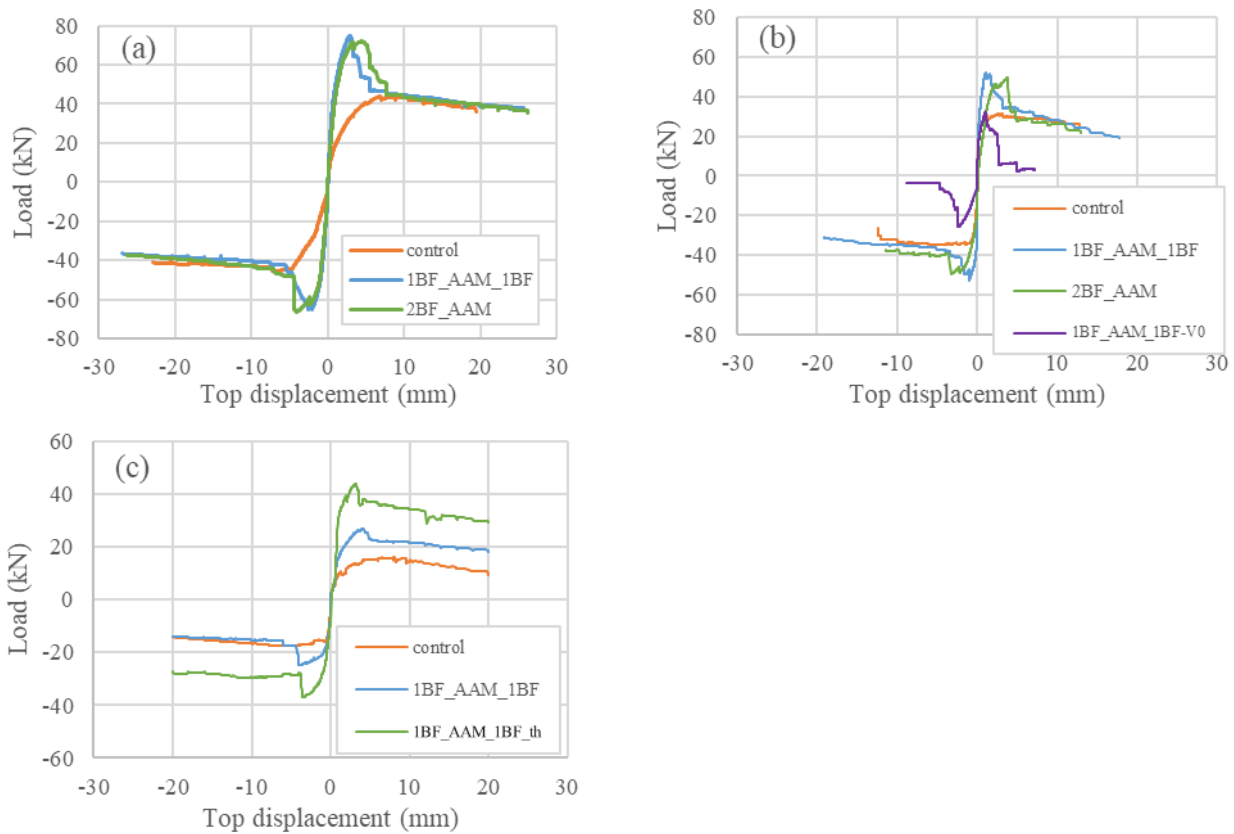

Figure 5-21 Hysteretic loop envelopes of AAM-based TRM strengthened walls for squat (a) and slender (b) specimens tested in-plane and specimens tested out-of-plane (c)

The results obtained have shown that AAM-based TRM can be used as an effective seismic strengthening material. The lateral in-plane load carrying capacity of natural stone masonry walls has increased approximately from 48% to 60% after applying two overlays of AAM TRM in total. On the other hand, out-of-plane lateral load capacity has increased by approximately 50% after applying 2

layers of AAM TRM on natural stone masonry walls. However, due to high alkalinity of the AAM mortar mix, particularly during the first seven days after applying, basalt textile sustains damage and tends to rupture prematurely. The latter stresses the importance of selecting proper material combinations (such as alkali-resistant fibres or coated textiles).

### 5.5.3 Retrofitting of concrete structures

The relative effectiveness and the applicability of AAM-based TRM on reinforced concrete (RC) structures, in view of seismic retrofitting, was examined through a series of experimental testing of short RC columns retrofitted with AAM-based TRM confining jackets subjected to horizontal cyclic loading with a constant axial load of 80 kN. For comparison reason, a traditional PC mortar was applied as well with the same uncoated carbon textile grid (170 g/m<sup>2</sup>). All columns were designed with a shear span of 360 mm and cross section dimensions of 160/240 mm. Each specimen was reinforced with eight 14 mm diameter longitudinal bars placed along the perimeter of stirrups.

Three columns were constructed with a stirrup spacing of 180 mm, out of which one was kept as unretrofitted (control) specimen, two were retrofitted with two- and four-layer AAM-based TRM confining jackets. An overview of the testing outcomes of the specimens is presented in Figure 5-22 with shear load – displacement hysteretic loop envelopes.

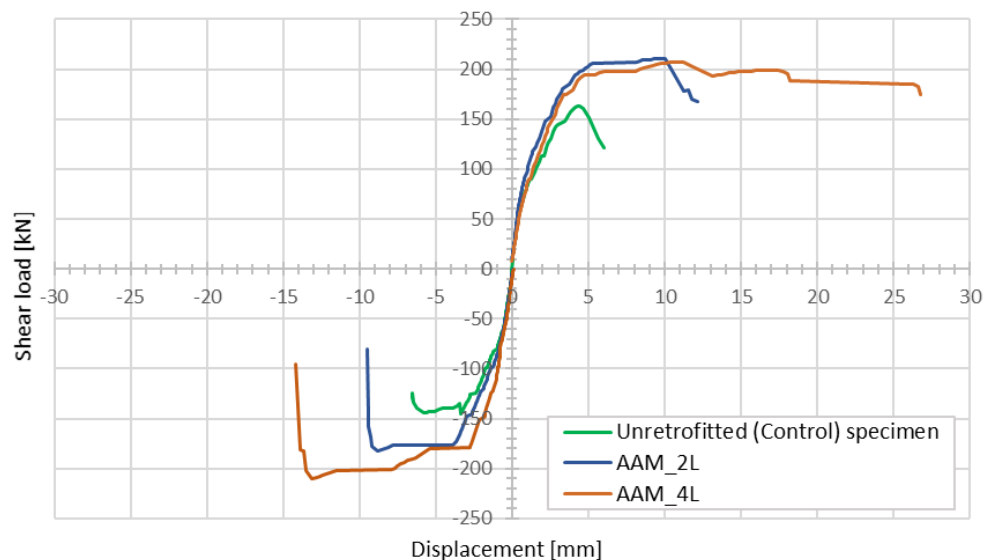

*Figure 5-22 Shear load-displacement hysteretic loop envelopes*

Application of two and four layers of AAM-based TRM jackets resulted with an increase of the shear capacity of 29.3% and 26.7%, respectively. A deformation capacity increase of 158.9% and 499% was observed, while an increase in total dissipated energy of 433% and 1272% was recorded with the application of two and four layers of AAM-TRM, respectively. No differences in the response between the specimens retrofitted with AAM-based and their PC-based counterparts were observed, which means that alkali-activated materials (AAM) could represent an adequate alternative to Portland cement (PC) binders in retrofitting of reinforced concrete structural elements.



# 6 ECONOMIC CONSIDERATIONS

## 6.1 Introduction

Whereas alkali-activated concrete has already a history of applications going back to the 1960's, the increased interest in AAM concrete that has been emerging over the last decade is largely associated with the societal need for more environmental solutions (see [Chapter 7](#)). Nevertheless, this market demand should go hand in hand with adequate technical performance (see [Chapter 4](#)) and commercial feasibility. This latter aspect is discussed in this chapter, in reference to the following economic considerations for the AAM concrete industry.

## 6.2 Material costs

### 6.2.1 Traditional Concrete

Raw materials costs can be considered one of the major influence factors on the price of concrete. Price fluctuations of these materials will therefor directly influence concrete pricing. In traditional concrete these materials include cement, water, sand, and coarse aggregates. Although concrete recipes of course can range significantly depending on the application, for simplicity of this section an average concrete recipe is used for the calculation, as presented in [Figure 6-1](#).

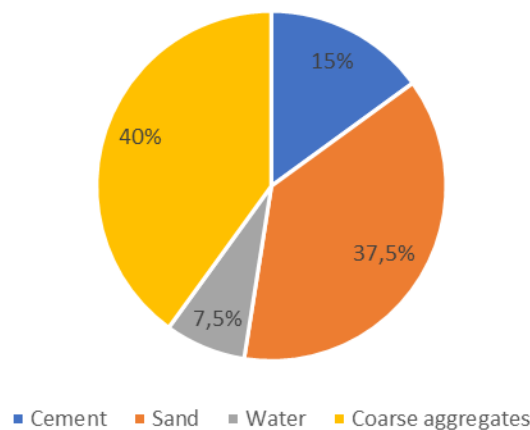

*Figure 6-1 Raw materials for concrete in weight percentage*

The same can be said for the prices of raw materials in Europe, which can vary greatly depending on the regional conditions and availability. A simplified overview in terms of orders of magnitude of cost price of raw materials is presented in [Table 6-1](#).

*Table 6-1 Price €/ton of concrete raw materials*

Material	Price €/ton
Cement	100
Sand	10
Water	2
Coarse Aggregate	20

Considering all the above and a density of 2400 kg/m<sup>3</sup> of concrete, the total raw material cost of m<sup>3</sup> of concrete is therefore around 65€. Noteworthy is that although cement only represents 15% of the total mass, it accounts for more than half of the raw material cost.

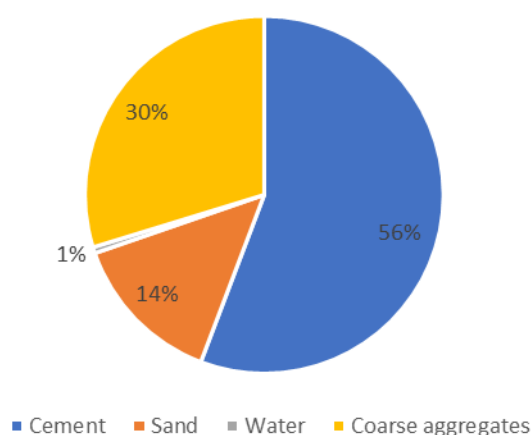

*Figure 6-2 Raw materials for concrete % of total cost of raw materials*

## 6.2.2 AAM concrete

AAM concrete differs in two ways from traditional concrete:

1. Cement is being replaced by secondary residues / low carbon raw materials in combination with a chemical activator
2. Primary aggregates are replaced by secondary or recycled aggregates

Therefore, the influence of AAM concrete on material cost lays within the difference between the price of these constituents. However, due to the great variety of mixture designs that can be adopted within the different URBCON technologies (AAM concrete formulations making use of local by-products available in urban areas), it's impossible to formulate a general conclusion on the influence on price. A deeper understanding on the topic is presented below.

### 6.2.2.1 Cost of secondary residues / low carbon materials and chemical activators

The list of potential binder materials as elaborated in [Section 3.3](#), show the difference between binder materials experiencing a huge competitive market as supplementary cementitious materials in conventional cement manufacture and those not readily commercialized in the market.

GGBFS and Coal Fly Ash are momentarily commonly traded and consumed in the cement market as supplementary cementitious materials. The market value of these products is therefore directly related to their reactivity in combination with traditional cement. For GGBFS this is about 80% of the cement price, while for Coal Fly Ash this number is around 40%.

The cost of non-commercialized binder materials is hard to generalize. However, due to the lack of (high value) applications and the waste status of most of these products, the value momentarily can be seen as very low to zero. Practically none of these are directly available for commercialization, meaning that the cost of pre-treatment should be factored into the equation. These costs will of course vary from material to material and will depend on the need for steps such as washing, drying, processing, milling. However, as the current value of these 'waste' materials are negative (equal to the cost of landfilling, at least 100EUR per tons), even pre-processed SRM could be made available at a market price no higher than f.ex Fly Ash.

The list of potential activators for these binder materials is presented in [Section 3.4](#). These activators are all abundant chemicals, available worldwide and although their prices can be significantly higher compared to the materials described above, their relative weight percentage in the concrete mix designs remain limited.

#### 6.2.2.2 Cost of secondary or recycled aggregates

No information on average values of the cost price of recycled aggregates for concrete is easily available. After consulting several producers of recycled aggregates, a selling price of 7 to 8 €/ton was noted at the time of writing this e-handbook.

### 6.3 Price trends resulting from emissions trading considerations

The construction sector has been faced with increasing raw material prices over the past years. With an average increase of 3 to 6% per year, with outliers as high as 15% due to the increasing lack of primary resources and increasing transportation costs. Moreover, because of the skyrocketing gas prices in 2021, prices of energy-intensive building materials such as cement are believed to undoubtedly rise too [359]. The price rise for cement has already been announced by all the major cement players and results in a staggering 30% rise over the year 2021 [360]. Since the price rise is informal, switching supplier is out of the question and the price rise is basically non-negotiable.

On the other hand, are policy makers in the EU pushing towards a carbon healthy market by driving down carbon pollution from Europe's industrial sectors. So far, the Emissions Trading System (ETS) has been the centrepiece of the EU's climate policy and main tool to reduce greenhouse gas emissions from Europe's industrial and power sectors. Until today, most emission reductions achieved under the EU ETS were driven by the power sector. On the contrary, carbon emissions from sectors such as steel and cement have barely decreased since CO<sub>2</sub> allowances have been received for free by these sectors up until now.

However recently, under the 2030 Climate Target Plan, the European Union has agreed to accelerate the pace at which the bloc reduces its greenhouse gas emissions. Key to meeting its new goals is the reformation of the EU ETS by progressively phasing out the free allowances that have been provided to large industrial facilities, such as the cement industry. According to analysts, these measures could raise the price of emissions allowances to 90-100 € per ton of CO<sub>2</sub> [361].

At the national or regional level, similar governmental drivers are sometimes in place, often associated with public procurement policies that in some way and degree also account for environmental cost indicators. Often this is associated with LCA calculations (see [Chapter 7](#)).

The increasing price rise for traditional cement in combination with the increasing efforts in green public procurement policies, can quickly create a market for low-carbon cement and concretes such as the URBCON developed products in the years to come.

## 6.4 Economic considerations with respect to energy consumption

The pie chart in Figure 6-3 shows the contribution of different processes to the non-renewable primary energy use to produce average German C25/30 concrete. The main contributor is cement production, followed by the extraction/production of aggregates and the transport of concrete constituents to the concrete plant. Energy consumption in cement production, on the other hand is mainly influenced by the provision of fossil fuels to operate the cement kiln and using electricity (Figure 6-4).

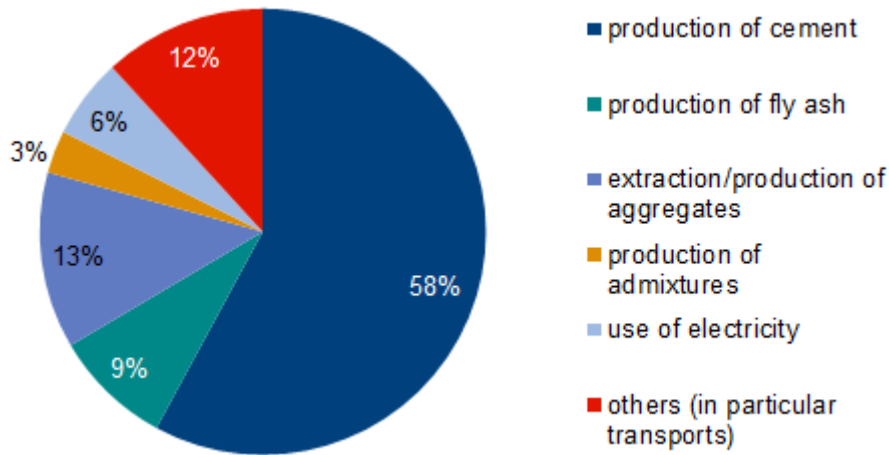

Figure 6-3 Contribution of different processes to the non-renewable primary energy use to produce average German C25/30 concrete [362]

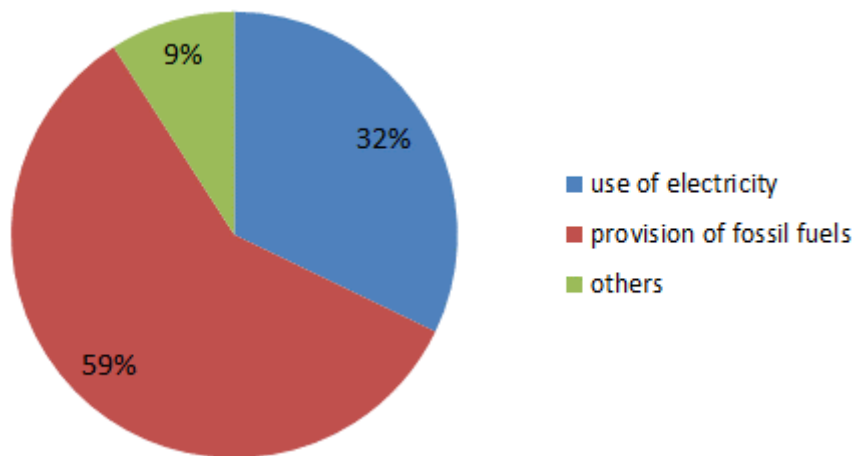

Figure 6-4 Contribution of fossil fuels and electricity to the non-renewable primary energy use to produce average European CEM II cement [362]

In cement production, over the past years, the primary energy demand per ton of cement for the provision of fossil fuels has decreased continuously due to the replacement of fossil fuels by alternative fuels. Alternative fuels, including a high proportion of waste products, are increasingly used and now represent almost a third of all fuels in the EU cement industry (Figure 6-5). Moreover, a slight reduction of the clinker-to-cement ratio has been achieved since 1990: clinker has been replaced by other constituents as limestone, granulated blast furnace slag or fly ash [362].

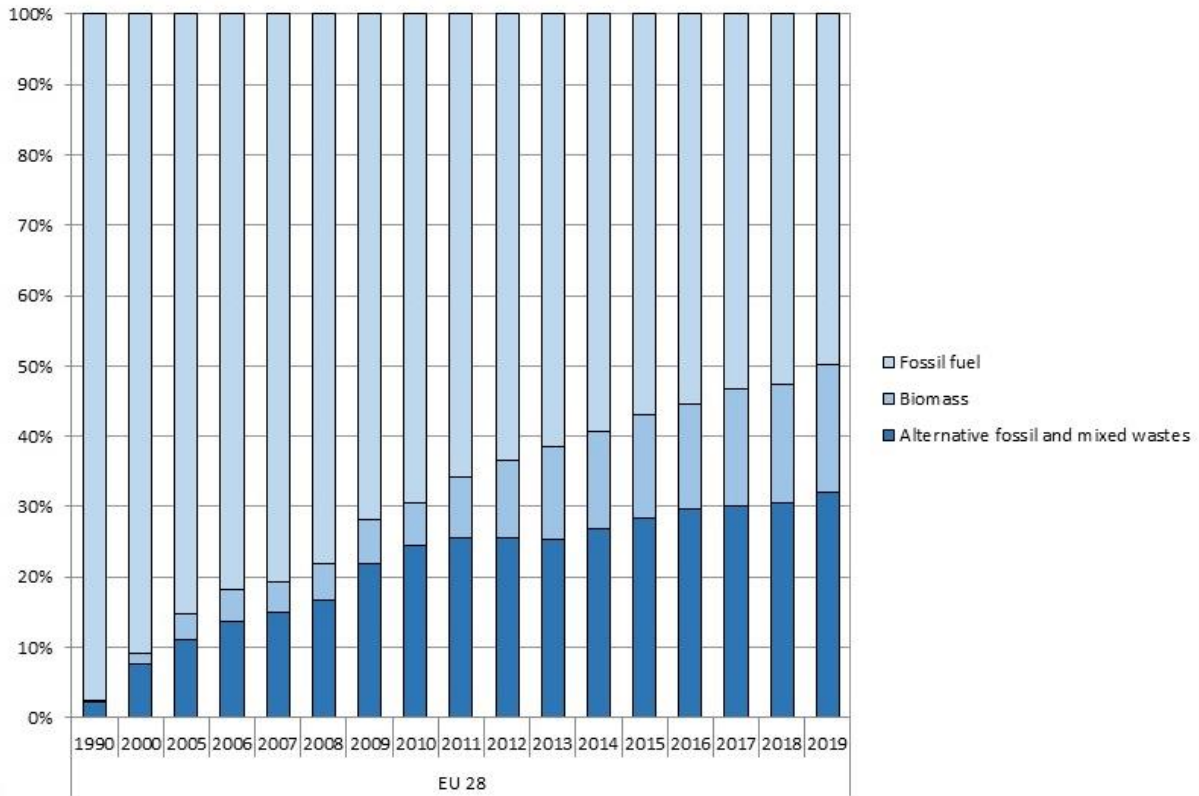

Figure 6-5 Thermal energy consumption (excluding drying of fuels), weighted average [364]

Electricity consumption for cement production has largely remained constant over the last years (average 117.0 kWh/t cement) in Europe (Figure 6-6). Due to the increasing proportion of renewable energy sources in the electricity grid mix, the primary energy demand for electricity consumption has nevertheless decreased.

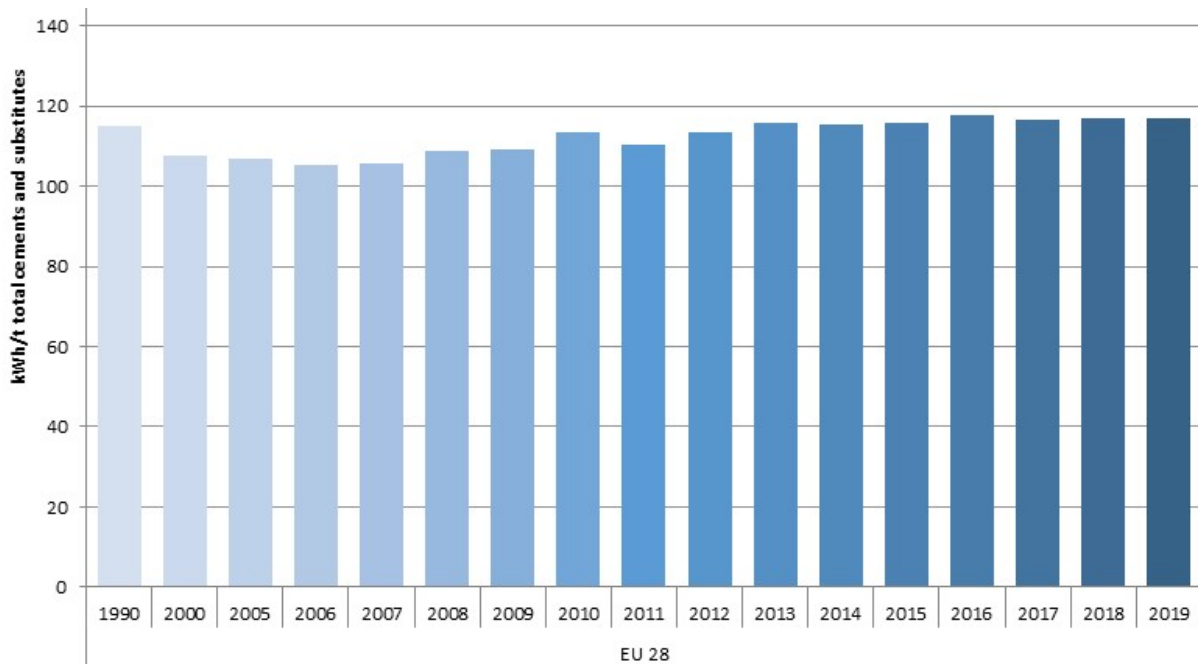

Figure 6-6 Cement plant power consumption (weighted average) [366]

## 6.5 Life cycle costing analysis

The primary aim of the LCCA (Life Cycle Costing Analysis) is to determine the economic performance of AAM concrete solutions expressed in both material (or wider market) costs and environmental costs. For the latter, an LCA study is performed (Chapter 7), so that the LCCA typically follows a similar approach, system boundaries and life cycle stages, as defined in the LCA. The methodology is based on EN 158045 and EN 16757 standards and the ISO 15686-5. A functional unit needs to be defined, taken as a basis for comparing different solutions. For example, 1 m<sup>3</sup> of unreinforced concrete can be considered.

An LCCA analysis has been conducted for four different AAM concrete mixes, that have been considered for the URBCON pilots. Hereby, data was collected by inquiring the URBCON partners, from the literature and from LCA inventory databases. The results are given in Figure 6-7, in terms of the material costs (left) and in terms of the environmental impact costs (right), considering 1 m<sup>3</sup> of concrete and only considering the production stage. Note that for simplicity these boundary conditions of the conducted LCCA have been chosen narrow, so that the results should be considered with care. For the environmental impact costs, the results from the LCA related to the impact category 'Global Warming Potential/Climate Change' for the production stage were converted to environmental costs by using a monetization factor of 0.1025 €/kg CO<sub>2</sub>-eq (as indicated by the European Commission).

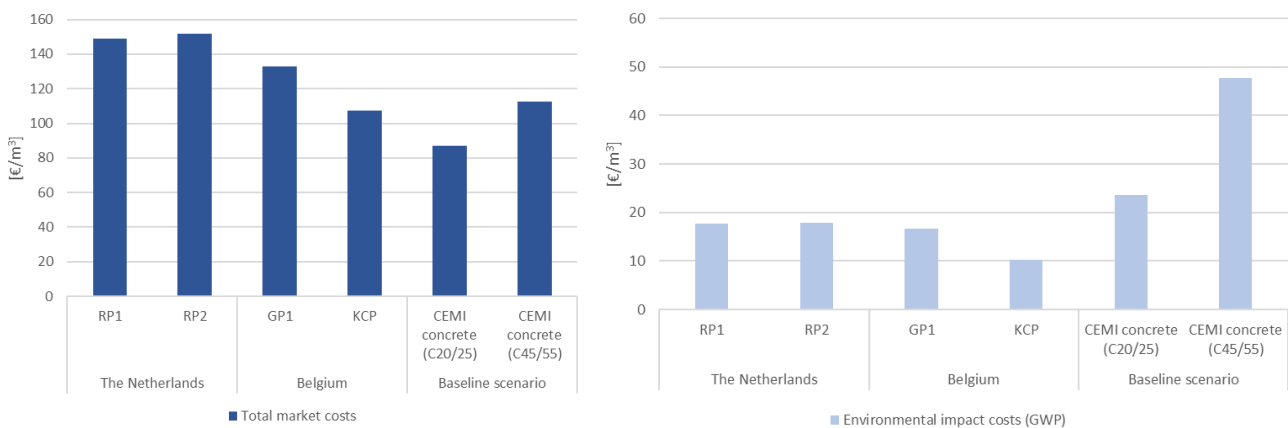

Figure 6-7 Material costs (left) versus environmental impact costs (right)

Some findings from the LCCA are as follows:

- The studied AAM mixes tend to have similar or higher material costs than the considered reference mix (C45/55). At the other hand their environmental costs are lower, so that they become attractive when the overall costs of both material and environmental impact are considered.
- The composition of the concrete mix influences the material cost structure significantly. As a result, minor adjustments can lead to substantial cost variations.
- A hybrid mix design, with predominantly alkali-activated binder yet complemented with a low amount of Portland cement binder, results in cost advantages.
- The cost competitiveness can be further improved with optimized production processes and wider adoption.
- In developing new AAM concrete variants it can be important to identify cost-efficient alternatives for materials and optimizing production techniques.
- Collaboration among stakeholders, research institutions, and policymakers can decrease costs and drive widespread adoption of AAM concrete.



## 6.6 Market barriers

Market issues or barriers associated with upscaling of AAM concrete are given in [Section 8.2.2](#), both from the perspective of producers as well as the cities acting as landlords. Amongst other these relate to cost concerns associated to the uncertainties of novel concrete technologies in a framework of narrow profit margins often applicable for high volume building materials, cost concerns of tailoring concrete solutions in making use of local available by-products, the slow process of establishing standards and certification schemes for these concrete innovations, PC concrete solutions that remain relatively cheap despite their environmental impact, circular building concepts might reduce the amount of certain construction works.

Given the growing number of demonstrators and applications ([Chapter 9](#)), certification initiatives that start to emerge for AAM concrete, standards that gradually start to provide openings for more eco-friendly building materials, initiatives on policy making ([Section 8.2](#)), introduction of LCA or environmental cost indicators in tenders, increased consideration of carbon dioxide trading mechanisms, gradual but consistent increase in cost of primary raw materials, increased knowledge volume generated by the research community, etc.; it is believed that there are growing opportunities to overcome these market barriers.

# 7 ENVIRONMENTAL CONSIDERATIONS

## 7.1 Introduction

One of the main driving forces for the utilisation of AAM concrete is its lower environmental impact, with focus on both reduced carbon footprint and avoidance of use of primary raw materials from Mother Earth. Amongst other, the European Green Deal [383] is driving the construction industry to increasingly focus on these environmental considerations. As a result, also economic considerations more and more need to account for environmental impact as was discussed in Chapter 6.

Though AAM concrete has a reduced environmental impact, at the same time it makes use of by-products that potentially could contain heavy metals. Checking the leaching behaviour of concretes, that make use of secondary materials that could be potentially harmful for the environment, is a requirement. By means of leaching tests full compliance is demonstrated to (European and national) legislation concerning environmental safety.

An important and often used metric to evaluate the environmental impact of materials, products and complete structures in the built environment is life cycle assessment (LCA). In the following an introduction is given to LCA calculations and LCA performance of different concrete types. Note that LCA is mainly focused on environmental aspects such as global warming potential (GWP) and is less suited as a metric on the use of secondary raw materials. Nevertheless, next to a favourable LCA score of eco-friendly concretes, the avoidance of primary raw materials is also considered of importance (and in the future they will be increasingly driven by increased cost price of primary sourced construction minerals).

## 7.2 What is life cycle assessment

In ISO 14040:2006 [367], Life Cycle Assessment (LCA) is defined as the compilation and evaluation of the inputs, outputs, and the potential environmental impacts of a system throughout its life cycle.

LCA is a broadly accepted methodology to assess the environmental impacts associated with all the stages of a product's life - from raw material extraction through production, transport, use, repair and maintenance, and disposal or recycling.

Life cycle assessment (LCA) comprises the compilation and evaluation of the

- inputs,
- outputs,
- the potential environmental impacts of the product system under study.

Inputs may include

- energy inputs (e.g., hard coal),
- raw material inputs (e.g., limestone),

- ancillary inputs (e.g., lubricating oil),
- precursor products, co-products, and waste.

Outputs may include

- products and co-products,
- releases/emissions to air, water, and soil,
- waste.

LCA aims at "stripping down" all processes in a product's life cycle back to the first extraction of material or energy resources from the earth's crust, up to end of life. This comprises not only the processes at the production facilities but all preceding/upstream processes. EN 15804+A2 [369] defines the specific information modules in this sense. Impacts must be reported where they occur.

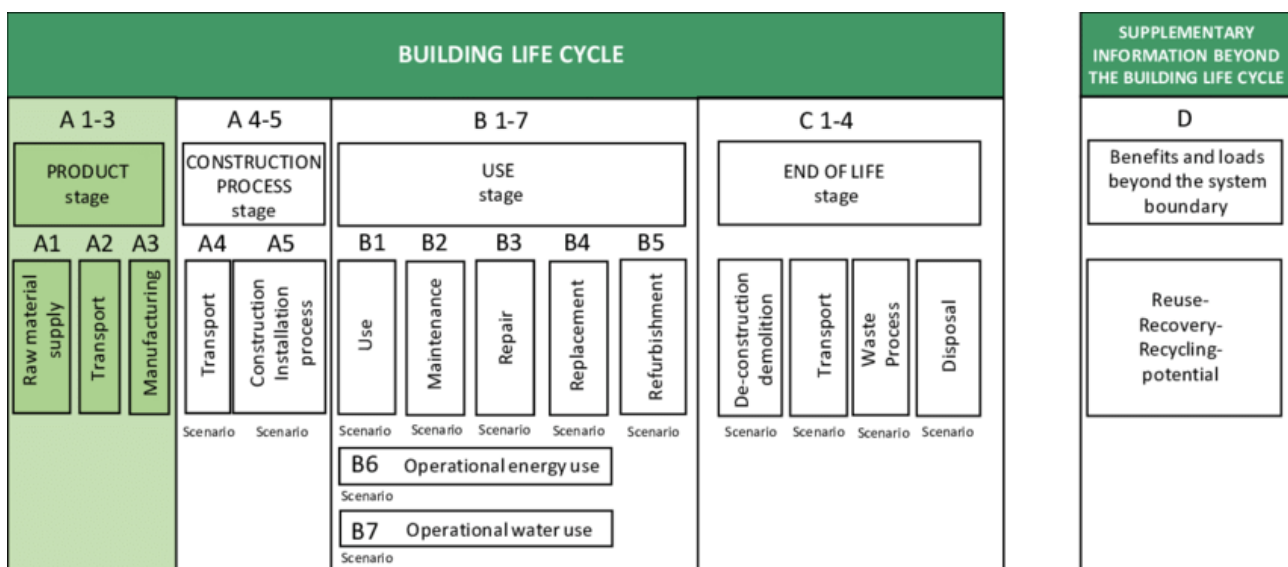

Figure 7-1 Life Cycle Modules according to EN 15804+A2 ([372] ,adopted from [369])

ISO 14044:2006 [367] defines four phases in an LCA study:

- The goal and scope definition phase.* In this first phase, the scope, including system boundary and level of detail, of an LCA depends on the subject and the intended use of the study.
- The inventory analysis phase.* The life cycle inventory analysis phase (LCI phase) is the second phase of LCA. It is an inventory of input/output data regarding the system being studied. It involves the collection of the data necessary to meet the goals of the defined study.
- The impact assessment phase.* The life cycle impact assessment phase (LCIA) is the third phase of the LCA. The purpose of LCIA is to provide additional information to help assess a product system's LCI results to understand their environmental significance.
- The interpretation phase.* Life cycle interpretation is the final phase of the LCA procedure, in which the results of an LCI or an LCIA, or both, are summarized and discussed as a basis for conclusions, recommendations and decision-making in accordance with the goals and scope.

The LCA conducted in the URBCON/DuRSAAM projects follows the rules of the standards

- ISO 14040:2006 [367]: Environmental management - Life cycle assessment- Principles and framework
- EN 15804+A2 [369]: Environmental product declarations - Core rules for the product category of construction products
- EN 16908 [370]: Cement and building lime - Environmental product declarations - Product category rules complementary to EN 15804

- EN 16757 [371]: Environmental product declarations - Product Category Rules for concrete and concrete elements

## 7.3 LCA framework in reference to cement production

### 7.3.1 System boundaries

#### 7.3.1.1 Life cycle stages covered

As cement is an intermediate product with many different final uses (ready-mix concrete, precast concrete, mortar, cement screed etc.), it is generally not possible to provide information about the environmental impacts of the product during the construction process, use, and end of life stages, as this will depend on how the cement is used.

According to EN 16908 [370], products which fulfil all the three conditions below shall be permitted to be exempt from the requirement to declare modules C1-C4 and module D:

- the product or material is physically integrated with other products during installation so they cannot be physically separated from them at end of life, and
- the product or material is no longer identifiable at end of life because of a physical or chemical transformation process, and
- the product or material does not contain biogenic carbon.

All three conditions are fulfilled for cement. This LCA therefore covers the modules A1 to A3: raw material supply, transport, and manufacturing.

#### 7.3.1.2 Visualization of the system boundaries

The system boundaries of cement production are shown in Figure 1 of EN 16908 [370] which are displayed in Figure 7-2.

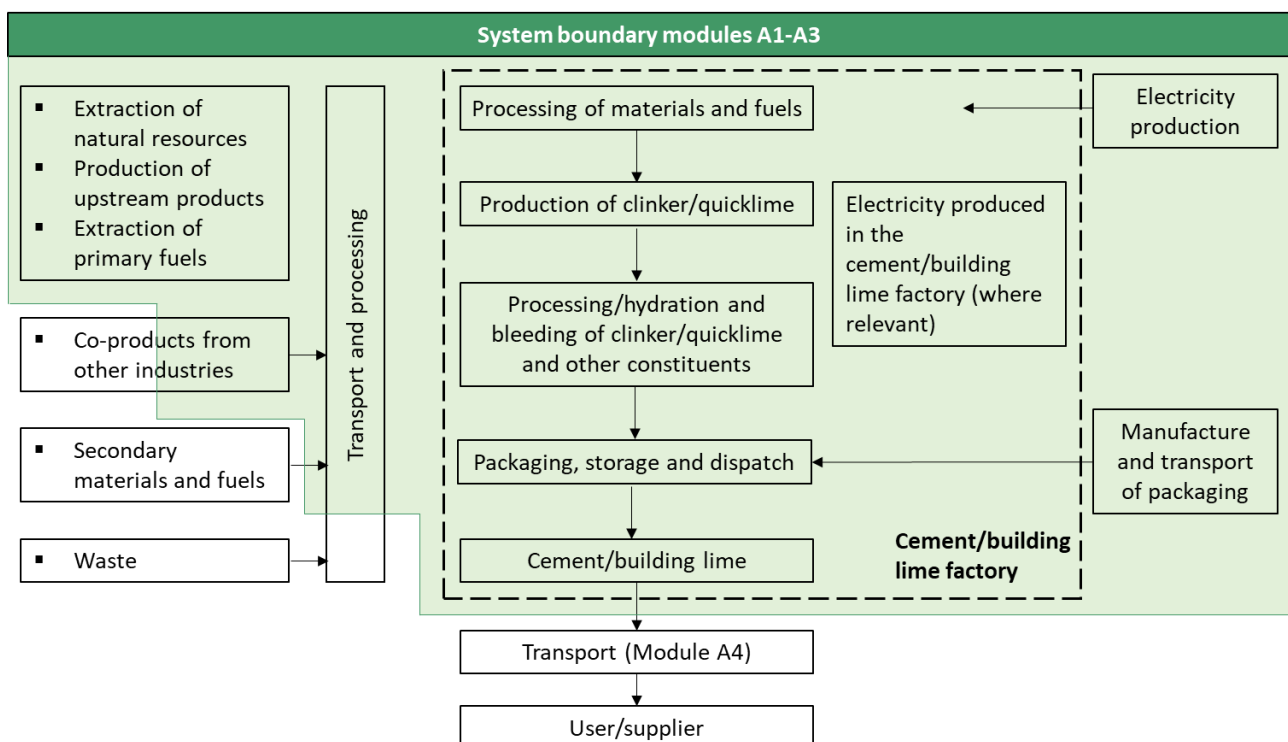

Figure 7-2 System boundaries of cement production acc. to EN 16908 [370]

### 7.3.2 Description of the life cycle modules covered

For cement, the processes that are included in modules A1 to A3 are summarised as follows:

#### 7.3.2.1 Module A1: raw material extraction and processing, processing of secondary material input

This module includes:

- extraction of raw materials. For cement this includes quarrying of calcareous materials, such as limestone or marl, sand, and argillaceous material, such as clay or shale.
- extraction of primary fuels. Major primary fuels used in the production of cement are coal, pet coke, lignite and natural gas.
- processing of co-products from other industries (e.g. blast furnace slag, fly ash), raw materials and fuels used for manufacturing the product. When waste from other industries is used, the processes that are part of the waste processing in the previous product system are not included in the system boundaries of cement production. According to the polluter pays principle, the system that generates the waste is accountable for these processes.

#### 7.3.2.2 Module A2: transport to the factory gate and internal transport

This module includes:

- transport of raw materials and fuels to the cement plant
- internal transports in the cement plants
- transport of raw materials and clinker to grinding mills (if applicable).

#### 7.3.2.3 Module A3: Production of ancillary materials or pre-products and manufacturing of products and co-products

This module includes:

- grinding of raw materials
- production of clinker: the raw mix is preheated using the residual heat of the flue gases and burned in a rotary kiln at about 1450°C. Fuel used is generally a mix of primary fuels, secondary fuels, and waste.
- processing (grinding etc.) and blending of the cement constituents (see “Composition of the products”)
- packaging operations in the case of bagged cement, storage of cement, preparation for dispatch
- processing up to the end-of-waste state or disposal of final residues.

The modules A1 to A3 are generally reported in an aggregated module A1-A3.

### 7.3.3 Main impacts on the LCA of cement production

#### 7.3.3.1 General

The bar chart in [Figure 7-3](#) shows the main factors influencing important environmental indicators of cement production.

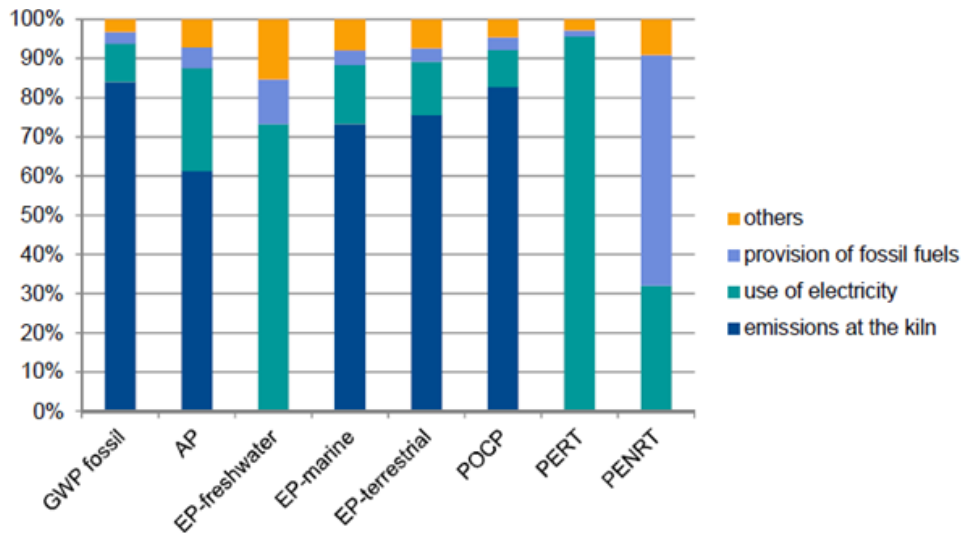

Figure 7-3 Cement production: main influence factors on the values of selected environmental indicators (CEMBUREAU representative CEM II) [363]

### 7.3.3.2 Clinker/cement factor – temporal development

The outcomes of the LCA of cement largely depends on the Portland clinker content in the cement. Given the wide range of cements used, it is not straightforward to consider a general value for the clinker/cement factor, in view of the LCA calculations. Reference could be made to common practice for a specific type of concrete application in a region. Alternatively, reference can be made to averaged data at national or European level (aggregated data for all types of concrete applications). The latter approach has been considered, by making use of the documented average clinker/cement factor in European given in Figure 7-4.

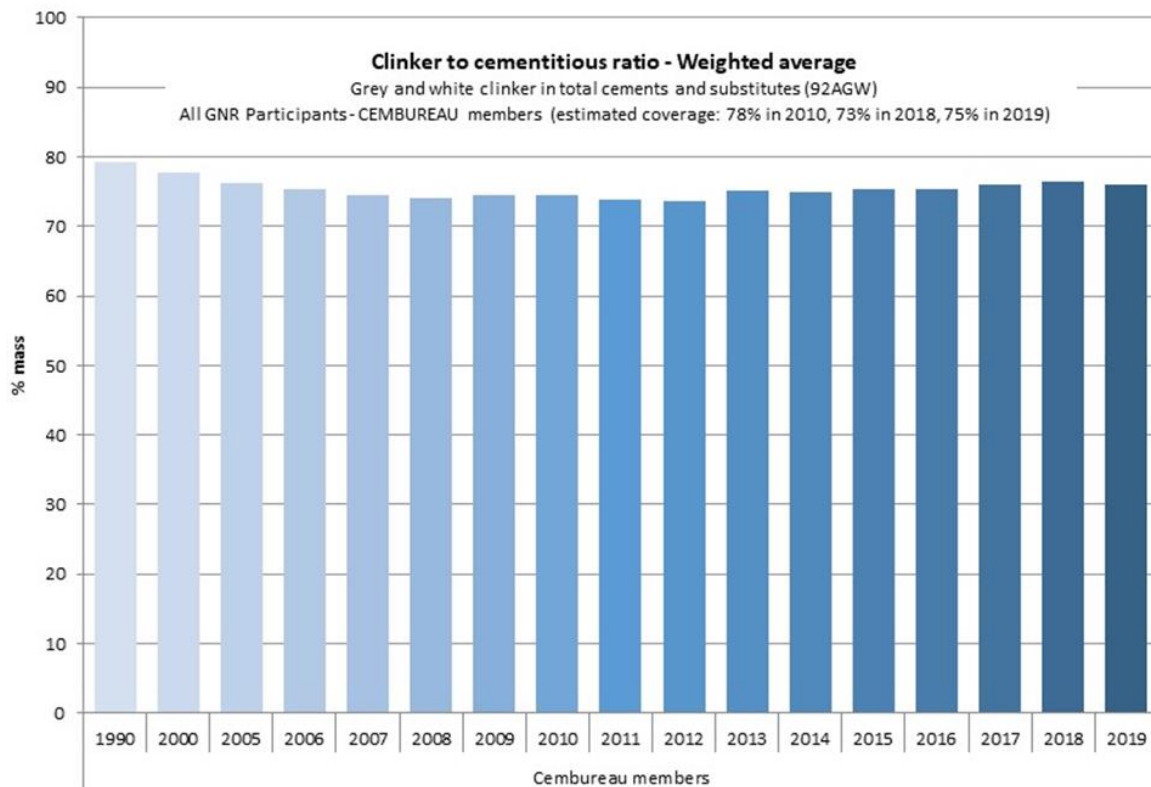

Figure 7-4 Clinker/cement ratio in CEMBUREAU member states 1990 until 2019 [363]



### 7.3.4 Emissions at the cement kiln

Releases from cement kilns originate from the physical and chemical reactions of the raw materials and from the combustion of fuels. The main constituents of the exit gases from a cement kiln are nitrogen from the combustion air, carbon dioxide (CO<sub>2</sub>) from calcination and combustion, water from the combustion process and the raw material and excess oxygen. The exhaust gases also contain small quantities of dust, chlorides (HCl), fluorides (HF), sulphur dioxide (SO<sub>2</sub>), nitrogen oxides (NOX), carbon monoxide (CO) and small quantities of organic compounds and heavy metals.

The Global Cement Database on CO<sub>2</sub> and energy information “Getting the numbers right” (GNR, e.g. [364]-[366]) specifies a "gross" value (including the CO<sub>2</sub>-emissions from the incineration of fossil waste but excluding CO<sub>2</sub>-emissions from the incineration of biogenic waste) of 815 kg CO<sub>2</sub> /t clinker for CEMBUREAU members (Indicator 59 cAG) in the year 2019 . For "net" emissions (i.e. excluding the CO<sub>2</sub>-emissions from the incineration of waste), 721 kg CO<sub>2</sub>/t clinker is a given (indicator 71AG).

### 7.3.5 Provision of fossil fuels

According to the GNR project database, the average consumption of thermal energy for clinker burning was 3.640 MJ/t clinker for CEMBUREAU countries in 2019 (excluding energy for drying of fuels). The thermal energy by fuel is given as indicator 25aAGFC (Table 7-1).

*Table 7-1 Thermal energy by fuel 2019*

Region	Fossil and mixed wastes	Biomass	Fossil fuel	Total
CEMBUREAU members	30.6 %	17.0 %	52.3 %	100%
	1114 MJ/t	619 MJ/t	1904 MJ/t	3640 MJ/t

Increasingly, waste and biomass have been used to replace fossil fuels. According to the ‘polluter pays’ principle in LCA, the system that generates the waste is responsible for declaring the impacts of waste processing until the end of waste stage is reached. However, according to the applied PCR, for the environmental indicators/parameters of cement production “gross” figures (i.e., including the environmental impacts from waste combustion and processing) or “net” figures (i.e. excluding emissions from waste combustion and processing) may be used. It shall be transparently stated whether gross or net figures are used. If the “net” figures are used, the “gross” figures should be also quoted for information and transparency purposes.

### 7.3.6 Use of electricity

In clinker production, electrical energy is mainly required for the processing of raw materials as well as the burning and cooling of the clinker. After the cement clinker has been produced, electricity is mainly used for the grinding of cement constituents. As cements with a higher strength are ground finer, more electrical energy is required for their production. As the electrical energy required for the grinding of blast furnace slag is higher than for clinker, the total value for blast furnace cement (CEM III) is generally higher than for CEM I. On the other hand, the grinding of main constituents as pozzolana and limestone consumes less energy than the grinding of clinker. Fly ash is already relatively fine when delivered to the cement plant. Therefore, for an average CEM II, less electrical energy is required for the processes following the clinker production.

### 7.3.7 Co-product allocation

Co-products from other industrial processes that are used in the production of cement are:

- blast-furnace slag (a co-product of steel production),
- fly ash (a co-product of coal-fired electricity production),
- silica fume (a co-product of the production of silicon metal and ferro-silicon alloys) and
- fdg gypsum (a synthetic gypsum obtained as a co-product of flue-gas desulfurization).

For co-product allocation, the rules of EN 15804 apply. As the industrial processes mentioned above cannot easily be subdivided, the impacts of production shall be divided amongst the co-products according to an allocation method reflecting the main purpose of the processes studied. According to EN 15804, allocation according to economic values shall be applied where the difference in the amount of revenue earned by the original producer for each of the co-products is high (greater than 25%). This is the case for co-products used in cement. Contributions to the overall revenue of the order of 1% or less are regarded as very low. Where this is the case, impacts from the process may be neglected.

## 7.4 LCA framework in reference to concrete production

### 7.4.1 System boundaries

#### 7.4.1.1 Visualisation of the system boundaries

The system boundaries of concrete are shown in Figure 7-5 [EN 16757]. Note that scenarios for the end-of-life modules can for example be found in environmental product declarations (EPDs) for concrete.

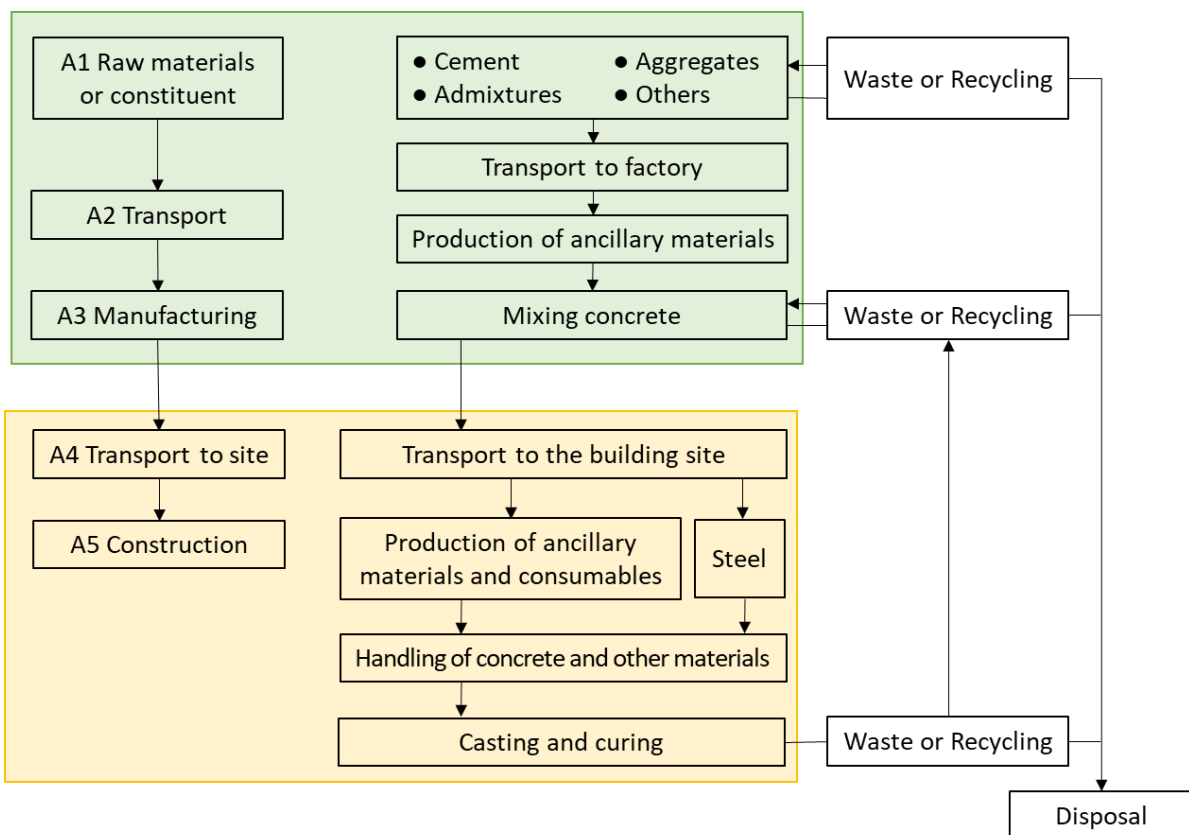

Figure 7-5 System boundaries of concrete production acc. to EN 16757 [371]

## 7.4.2 Description of the life cycle modules covered

In the context of the URBCON project, only the product stage (Modules A1-A3) is assessed. A more extensive LCA can also account for the service life of the concrete and has been explored in the DuRSAAM project.

For concrete, the processes that are included in modules A1 to A3 are summarised as follows.

### 7.4.2.1 Module A1: raw material supply

This module includes:

- the production of cement, admixtures, and additive
- the extraction, production, or processing of aggregates
- the provision of water.

For reinforced concrete elements, in addition, steel reinforcement may be considered.

### 7.4.2.2 Module A2: transport to the manufacturer

This module includes the transport of the concrete constituents to the ready-mixed concrete or precast plant.

### 7.4.2.3 Module A3: manufacturing

This module includes (for ready-mix concrete):

- conveying and mixing of the concrete raw materials.

In addition, for precast concrete elements, Module A3 may include

- the production of formwork
- concrete compaction
- curing, if necessary, by heating.

Modules A1 to A3 may be declared as one aggregated module A1-A3.

## 7.4.3 Main impacts on the LCA of concrete production

### 7.4.3.1 General

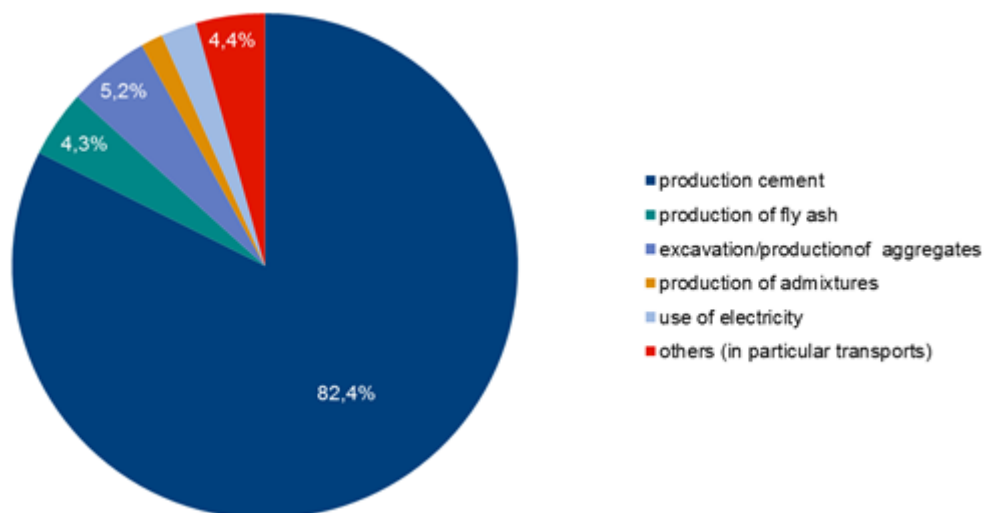

Figure 7-6 Concrete production: main influence factors on Global Warming Potential (Germany: IZB C25/30) [362]

Figure 7-6 shows the main influence factors on the Global Warming Potential of the production of average ready-mix concrete (strength class C25/30) produced in Germany. Cement production contributes to more than 82% to the GWP of concrete production (Modules A1 to A3).

#### 7.4.3.2 Production of cement

See previous section on the LCA framework in reference to cement production.

#### 7.4.3.3 Production of additions

EN-206-1 defines additions as finely divided materials used in concrete to improve certain properties or to achieve special properties.

EN 206 distinguishes between:

- nearly inert additions (Type I); as e.g., filler aggregates or pigments
- pozzolanic or latent hydraulic additions (Type II), as e.g., fly ash or silica fume

Fly ash is a pozzolanic addition. It is composed of fine-grained combustion residues that are captured in electrostatic precipitators for cleaning exhaust gases from coal-fired power plants. It is therefore a co-product of electricity generation in coal-fired power plants.

Since the processes for generating electricity and generating fly ash cannot be separated from one another, an allocation procedure must be used in LCA. The difference between the revenue of a coal-fired power plant generated by the products "electricity and "fly ash" "is large (> 25%). Therefore, according to EN 15804 [369], economic allocation is used for the environmental impacts from electricity generation. Contributions to the overall revenue of the order of 1% or less are regarded as very low. Where this is the case, impacts from the process may be neglected.

Other Type II additions are:

- ground granulated blast furnace slag (cf. paragraph 3.4)
- silica fume, a co-product of silicon and ferrosilicon alloy production. As for the other co-products used in cement and concrete production, for silica fume, economic allocation is applied in LCA.

#### 7.4.3.4 Production of admixtures

Admixtures are specially formulated products that are added in small amounts to concrete, during the mixing process to modify the concrete properties in the plastic and / or hardened state. They are usually water-based solutions and can be added to the concrete at up to 5% on cement weight, although most types are added at less than 1.5% [EFCA] [373]. The admixtures most frequently used are plasticisers and superplasticers. LCA data is provided by Admixture Associations (e.g. <http://www.efca.info/efca-publications/environmental/>) or in commercial databases.

#### 7.4.3.5 Excavation/production of aggregates

For the life cycle assessment of the extraction/production of natural gravel, sand and crushed aggregates, typically generic data sets, e.g., from databases are used.

By enlarge this is also done for secondary aggregates, considering additionally the following. Recycled aggregates from the reprocessing of concrete demolition waste are increasingly used in concrete production. The associated impacts are declared in Module C3 until the end of the waste status has been reached, which is typically the case when crushed concrete material can be used as backfill material, e.g., in road construction. For the use of the recycled aggregates in fresh concrete, usually further processing steps (crushing, sieving) are required. The environmental impacts of these additional steps are declared in module A1 of the fresh concrete.

### 7.4.3.6 Use of electricity

Electricity in concrete plants is required for e.g., mixers, conveyor belts, elevators, compressors, feeding screws and pumps. Preferably, in LCA the electricity mix of the specific plant or region assessed should be considered.

## 7.5 LCA of URBCON/DuRSAAM AAM concretes

### 7.5.1 LCA of AAM reference mixes

#### 7.5.1.1 Scope

As reference mixes within the DuRSAAM and URBCON projects were used alkali-activated concrete mixes made with traditional precursors, such as ground granulated blast furnace slag (GBFS), fly ash (FA) and metakaolin (MK), that have been previously reproduced in different countries through a RILEM TC 247-DTA round-robin test [374]. LCA of these selected reference mixes has been performed, where detailed results are presented in [375]. Hereby, the goal of the LCA is to analyse the environmental impacts associated with the production of selected AAM concrete reference mixes and compare to environmental impacts of conventional Portland cement (PC) concrete. Furthermore, the variability in the production processes of primary materials and uncertainty associated with transportation distances are examined, to identify which parameters contribute the most to the total LCA uncertainty of alkali-activated and PC concretes. The parameters with the highest contribution to the total uncertainty indicate the most sensitive areas for further improvement of AAM mix designs, allowing to minimize the total environmental impacts associated with AAM production.

The examined AAM mixes are presented in Table 7-2, and are compared to the PC concrete (CEM I) with equivalent compressive strength. The cement content has been estimated using Feret equation [123][376]:

$$f_c \approx KR_{C28} \left( \frac{V_{cement}}{V_{paste}} \right)^2$$

where  $f_c$  is the compressive strength,  $K$  is a parameter that characterizes the aggregates quality,  $R_{C28}$  is the specific mechanical strength of cement,  $V_{Cement}$  is the volume of cement and  $V_{paste}$  is the volume of paste which includes air, water and cement [376].

Therefore, the functional unit applied in the analysis is defined as 1 m<sup>3</sup> of concrete with equivalent compressive strength.

Table 7-2 Mix design parameters of the AAM concretes (adapted from Provis et al. (2019) [374])

Mix	Precursor	NaOH	Sodium silicate	Sand	Gravel	Water	Density	Compressive strength	Cement eq.
	(kg)	(kg)	(kg)	(kg)	(kg)	(kg)	(kg/m <sup>3</sup> )	(MPa)	(kg)
GBFS-AAM	375	15	10	729	1093	153	2375	52	385
FA-AAM	425	25	70	686	1028	116	2350	52	440
MK-AAM	350	9	113	611	917	186	2186	58	566

The system boundaries of performed analysis are based on 'cradle-to-gate' framework, which includes acquisition and processing of raw materials and transportation to the manufacturing site. As the examined mixes were cured at room temperatures [374], the conditions associated with

manufacturing of alkali-activated concrete and PC concrete at a concrete plant are assumed to be similar and therefore, the environmental impacts of manufacturing stage are not examined in details. To quantify impacts associated with transportation of mix constituents to concrete production plants, the concrete production is assumed to take place in Belgium, where some materials are assumed to be locally sourced, while others transported from the neighbouring countries.

The life cycle analysis was conducted using SimaPro software, where modelling of environmental impacts was performed using CML IA Baseline impact assessment method [377].

### 7.5.1.2 Life Cycle Inventory

The life cycle inventory data were collected from the Ecoinvent database v3.4, environmental product declarations (EPDs) and from available literature (Table 7-3). The quantified environmental impacts per unit process are published in [375].

*Table 7-3 Sources of inventory data and types of variability associated with input processes*

Material	LCI Source	Type of variability & uncertainty
Sodium silicate	CEES – Centre Européen d’Etudes des Silicates, Ecoinvent	Production technology
Sodium hydroxide	Ecoinvent	Production technology
GBFS	Ecoinvent, EPDs, [378]	Production technology
FA	Ecoinvent, EPDs, [378]	Production technology
Metakaolin	Ecoinvent, [376][379]	Production technology (source of energy used for kaolinite calcination)
Sand	Ecoinvent	Data quality
Gravel	Ecoinvent	Data quality
Water	Ecoinvent	Data quality
Cement	Ecoinvent, EPDs, [380]	Production technology
Transportation	Ecoinvent	Transportation distances

The recent data on sodium silicate production has been collected from the CEES group which is representing European Silicate Industry (“CEES – Centre Européen d’Etudes des Silicates”), where variability in production process across production sites has been observed. Chlor-alkali industry produces sodium hydroxide with a ratio of 1.1 to 1 between caustic soda and chlorine. The main technologies applied in Europe are membrane and diaphragm cells [381]. The life cycle inventory of these production processes was obtained from the Ecoinvent database.

In this study, GBFS and FA are considered as industrial by-products and not waste materials, since both precursors are produced as an integral part of a main production process, and both materials are already applied in concrete industry as supplementary cementitious materials (SCMs). Therefore, environmental impacts attributable to GBFS and FA production include share of emissions associated with primary production process, as well as emissions attributable to by-product’s pre-treatment. The economic allocation method has been determined as more advantageous over mass allocation for GBFS and FA [378][382]. While EPDs cover environmental impacts associated with by-products pretreatments itself including, the emissions associated with primary production processes, such as pig iron production and electricity production are obtained from the Ecoinvent database.

Another material used as precursor is metakaolin, which can be defined as a primary product, produced by calcination of 1.16 kg kaolinite at 600-900°C, equivalent to 2.5 MJ of energy consumption per 1 kg of final product [379]. The variability in environmental impacts of MK therefore



is examined by variation in energy sources used for calcination [376]. The different energy sources were analyzed using Ecoinvent database. Finally, the LCI of Portland cement has been estimated based on the EPDs available from different cement producers across Europe.

### 7.5.1.3 LCA results

Results of life cycle impact assessment of AAM concretes, compared to the PC concrete with equivalent compressive strengths are illustrated in Figure 7-7. Here, average environmental impacts of Portland cement concrete are considered as 100%, and variability across cement production sites is illustrated with dashed lines.

Depending on the impact category, the environmental impacts of AA concretes vary significantly relatively to the PC concrete. Within the Global Warming Potential (GWP) impact category all AA concretes have lower CO<sub>2</sub> eq. emissions compared to PC concrete, also considering the variability in cement production processes. On average, GBFS-based AA concrete has 57% lower CO<sub>2</sub> eq. emissions, FA-based AA concrete has 42% lower and MK-based concrete has 39% lower, compared to PC (CEM I) concrete.

The sodium silicate contributes between 5% and 28% to the total environmental footprint of AAMs, and total activator content including sodium hydroxide is responsible for less than 35% of CO<sub>2</sub> emissions across the AAM mixes. Furthermore, transportation has little contribution to the total impacts, however not negligible, specifically for metakaolin, which must be transported from abroad. Thus, it can be observed that the major contributions to the total environmental impacts of AAM mixes are made by activators and MK production.

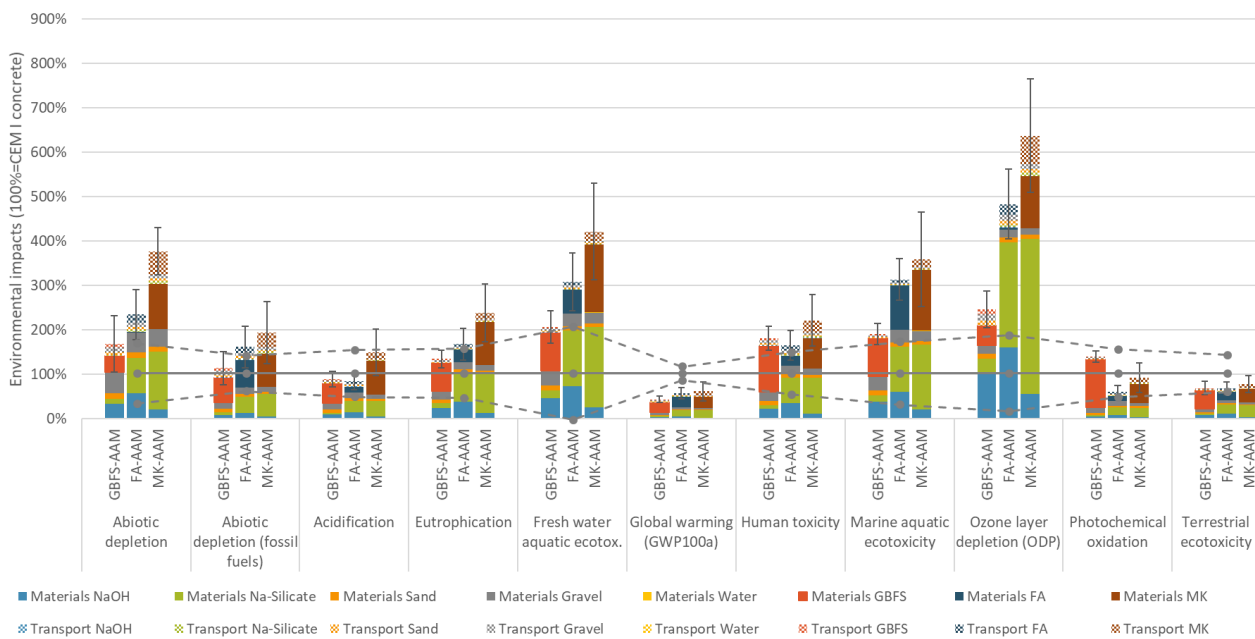

Figure 7-7 Environmental impacts of AAM mixes, compared to PC concrete including quantified variability and uncertainty

The uncertainty associated with quantified environmental impacts of examined concrete mixes is illustrated with error bars in Figure 7-8. The contribution of different input parameters to the total uncertainty of results varies between impact categories and between mixes under consideration. Variability in GBFS and MK production has relatively big contribution to the total uncertainty of mixes. While MK uncertainty comes from the type of fuel used for kaolin calcination [376], for FA and GBFS uncertainty is associated with variability in production processes arising mainly from different energy

consumption and internal transportation at the production facilities. This implies that there is little variability observed at FA processing plants, which can be attributable to homogenised production processes or to small amount of observations from production facilities. Variability in sodium hydroxide production technology has little impact on total uncertainty of results. Whereas variability observed among sodium silicate production plants has a big contribution to the total uncertainty, specifically for FA-AAM and MK-AAM mixes. For example, within GWP impact category it contributes approximately 48% to the total uncertainty of FA-based AAM. The uncertainty associated with data quality of gravel production in the Ecoinvent database has major contribution to the abiotic depletion indicator. This would suggest a need to improve database data on that material. The contribution of uncertainty associated with transportation to the total uncertainty is nearly 50% within GWP and ozone layer depletion categories. Although higher uncertainty is associated with transportation of precursors compared to transportation of Portland cement, transportation of both precursors and activators contributes less than 20% to the total uncertainty of environmental impacts.

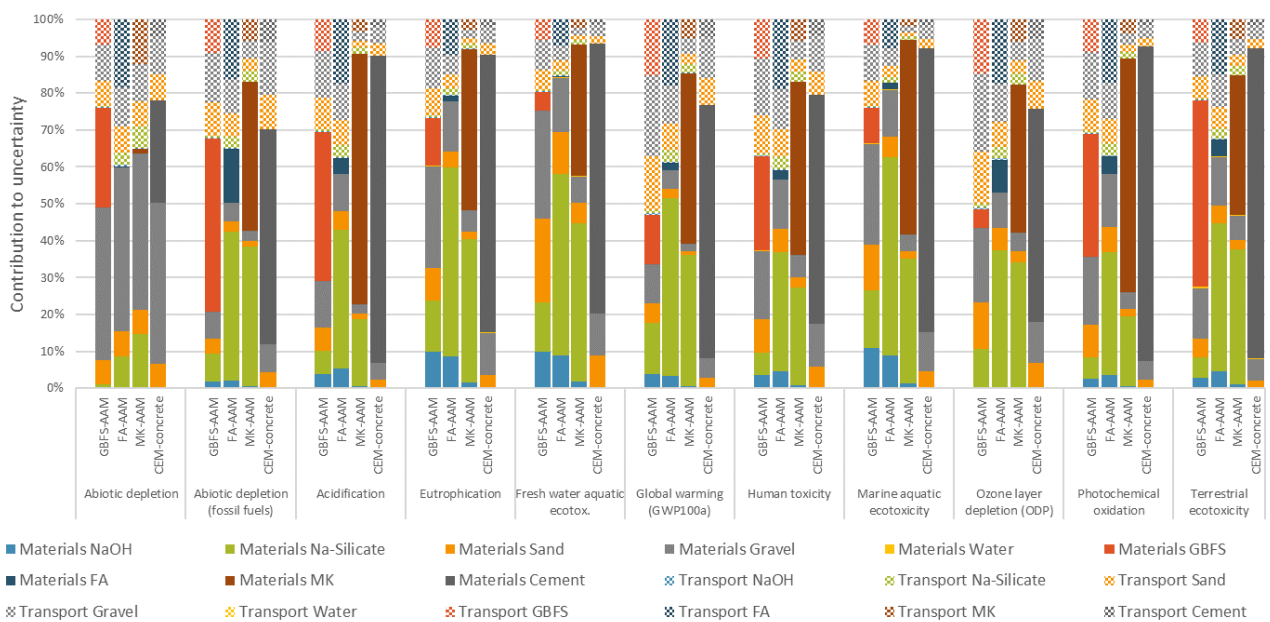

Figure 7-8 Uncertainty associated with production of mix constituents

#### 7.5.1.4 Summary of LCA performance

The LCA of reference mixes shows that AA concrete mixes can have between 57% (GBFS-based AAM) and 39% (MK-based AAM) lower total GWP, compared to considered reference Portland cement concrete. Activators including sodium silicate and sodium hydroxide contribute between 13% and 33% to the total CO<sub>2</sub> eq. emissions of AAM concretes. The GWP of AAM mixes remains lower than of Portland cement concrete mixes, also when variability in the production of constituents for both AAMs and PC concrete and uncertainty associated with transportation distances are considered. It has been observed that variability in sodium silicate as well as in GBFS and MK production processes have big contribution to the total uncertainty of LCA results. While uncertainty associated with transportation distances of precursors and activators contributes less than 20% to the total uncertainty of environmental impacts.

To minimize the environmental impacts of AAM concrete production it is important to select the precursors and activators, including waste-derived materials with lowest environmental impacts, where life cycle data obtained from individual producers would allow to optimize decision-making process.

Finally, it is important to assess durability properties of concrete structures, as predicted service lifetime can have a crucial impact on the whole life cycle assessment of AAM concretes, where repair and replacement of concrete cover within the target service life time shall be taken into account during planning stage.

### 7.5.2 LCA of URBCON concrete

Further to the above mentioned AAM reference concretes, the LCA of 4 alternative AAM concretes were calculated, that make use of local by-products and recycled aggregates. The considered recipes can be found in Table 7-4. The LCA result in terms GWP/m<sup>3</sup> of concrete is given in Table 7-5. Figure 7-9 is showing the influences of different components on the GWP.

Table 7-4 URBCON concrete mixes investigated by LCA

		Rotterdam pilot RP 1 (C45/55)	Rotterdam pilot RP2 (C45/55)	Ghent pilot GP1 (C50/60)	Kamp C Pilot KPC (C20/25)
		kg/m <sup>3</sup>			
Coarse aggregate	Gravel	1009	505	1122	900
Coarse aggregate	Recycled aggregates	0	453	0	0
Fine aggregate	Sand	618	618	733	780
Precursor	GGBFS	500	500	127	263
Precursor	Copper slag (Koranel)	0	0	214	52
Precursor	Stainless steel slag	0	0	61	0
Precursor	CEM I 52,5R	0	0	0	35
Alkali activator	Sodium hydroxide (NaOH)	20	21.8	12	0
Alkali activator	Na <sub>2</sub> O.2SiO <sub>2</sub>	17.5	19.1	0	0
Alkali activator	Water Glass	0	0	116	0
Alkali activator	Slag intensifier	0	0	0	11
Additive	Superplasticizer	0	0	0	1.5
Water		210	229	94	150

Table 7-5 GWP/m<sup>3</sup> for the URBCON concrete mixes

	Rotterdam pilot RP1 (C45/55)	Rotterdam pilot RP2 (C45/55)	Ghent pilot GP1(C50/60)	Kamp C Pilot KPC (C20/25)
	kg CO <sub>2</sub>			
GWP	173	173	163	100

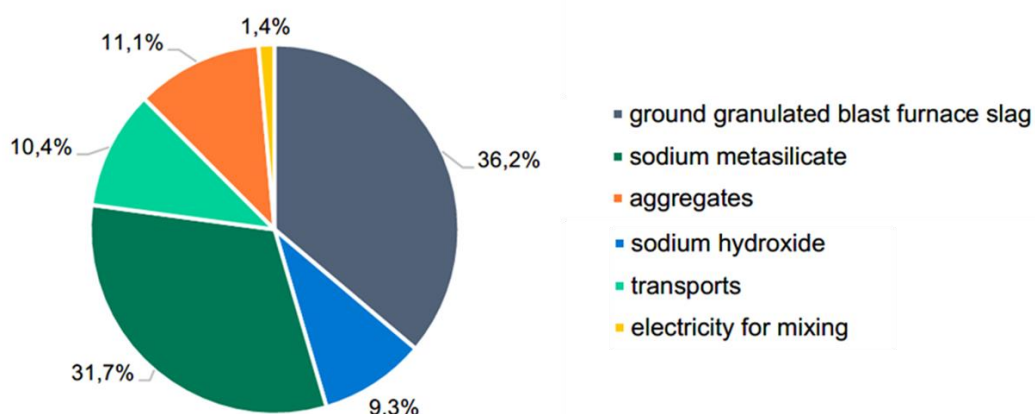

Figure 7-9 Influence of different components on the GWP (for mix RP1)

In the framework of the pedestrian bridge URBCON pilot at Rotterdam (Section 9.3), an LCA evaluation was also done by an independent consultant (NIBE). The LCA compared the GWP of 2 AAM concrete mixes considered for that specific pilot, with that of the concrete PC mix that would have been normally used. The LCA methodology followed a similar approach as listed above. Both AAM mixtures score well on environmental impact, as reported in Table 9-5. The results are in-line with what is reported in in Table 7-5.

## 7.6 Environmental considerations in terms of leaching

Alkali-activated concrete production makes use of by-products as secondary raw material. Given the origin of these by-products, often in the past also regarded as wastes that are landfilled, concerns might be raised if heavy metals are present in these by-products and could potentially leach.

In this respect reference can be made to the following European framework directive: Directive (EU) 2018/851 of the European Parliament and of the Council of 30 May 2018 amending Directive 2008/98/EC on waste (this document is also referred to as the 2018 edition of Directive 2008/98/EC). Note that this framework directive is generally implemented at the national level by specific implementation directives. Consequently, the use of secondary resources for concrete production (such as by-products and construction and demolition wastes) and the resulting concrete products, are generally subject to declarations of environmental safety. The latter is verified by means of leaching tests, in reference to specific standards and whereby harmful leachates should be limited according to boundaries specified in these legislative documents.

Concrete formulations making use of by-products, either in the form of SCM in PC based concrete or in the form of precursor in AAM based concrete, should therefore always be carefully screened for their leaching behaviour. This can be done at 3 levels:

- (1) Environmental safety of the secondary raw materials used to make concrete. These materials being in a coarse form such as secondary or artificial aggregates, or in a powder-like form such as binders (SCM or precursor), should be safe in terms of leaching to store outside and to be handled by workers.
- (2) Environmental safety of the concrete product. The produced concrete product (either a precast element or an in-situ formed concrete member) should be safe in terms of leaching, given that it might be for example exposed to water that triggers leaching of substances. Given that the concrete product is a combination of different constituent raw materials and given that this combined material might have a somewhat different leaching behaviour, this second level is often relevant in addition to the individual verification of the constituents (level 1).
- (3) Environmental safety of the concrete after end-of-life. After end-of-life the produced concrete product (as mentioned in level 2) can be given a further function, in view of circular construction principles. Amongst other, the concrete might be crushed and reused as recycled aggregate. Leaching tests on crushed material should demonstrate that the concrete remains also environmentally safe after its end-of-life.

Note that at the level of secondary raw materials (level 1 above), the by-products are generally treated to make them well suited and of consistent quality for further use as a construction mineral. Such treatment might include extraction of heavy metals, for those by-products that would not fulfil environmental safety legislations. At the level of the concrete products, the leaching tests on the crushed material (level 3, versus solid material at level 2) can be often regarded as more critical (in which case testing at level 2 might not always be required).

In terms of leaching testing, often reference is made to the so-called column test. In this test water (or other leaching solution) passes through a column of solid sample material (such as crushed concrete) to trigger the dissolution of contaminants from the sample material. Next, the leachate is analysed for the presence and concentration of contaminants, such as heavy metals.

## 8 CIRCULAR TRANSITION AND TENDERING

### 8.1 Introduction

In the framework of more circular construction and more eco-friendly building materials, a transition is needed of daily habits and practices of the landlords and design teams of new building projects. The success of this transition significantly relates to barriers associated with upscaling of AAM binder or AAM concrete, and that amongst others can be tackled through policy making. Governments increasingly pay attention to policy making toward circular transition, though the degree, ways and uniformity of such policy making is yet largely diversified and sometimes perceived as slow, underutilized, or still in a process of seeking. Furthermore, public procurement policies as well as private initiatives can give incentives on the use of more eco-friendly building solutions, such as URBCON concrete. In the case of building projects, the tendering document is critical in determining to which degree innovative solutions with reduced environmental impact are open for consideration. During the URBCON project 3 major pilots have been constructed ([Chapter 9](#)) that included proper reflection of the way of tendering. Different tendering approaches have been followed for these pilots and can be inspirational for future projects. Note however, on the somewhat longer term, as AAM concrete will become more widely applied and more developed in terms of building construction guidelines and technical certifications, standard tendering practices will become more and more applicable. Further to the tendering practices applied during the construction of the pilots, these demonstrators provided an excellent opportunity for learnings. These are extensively reported in the 3<sup>rd</sup> part of this chapter.

### 8.2 Policy making towards circular transition

#### 8.2.1 Setting the scene

The development of URBCON (AAM concrete making use of local by-products) is of interest for ‘The European Green Deal’ [\[383\]](#), which is an elaboration of the UN Paris Agreement [\[384\]](#) for the European context. The goal of the Green Deal is for Europe to become the first climate-neutral continent by 2050 at the latest. The Green Deal provides a European plan for the period of 2019 - 2024, consisting of various building blocks, i.e., action plans and strategies for specific sectors and themes as illustrated in [Fout! Verwijzingsbron niet gevonden.](#)

The national and local policies of URBCON’s partners are in line with the Paris Agreement in terms of climate targets. However, for circular economy the area of focus, targets and strategies are diversified. Therefore, it is advised to follow the line of ‘The European Green Deal & Circular Economy Action Plan’ [\[385\]](#): climate neutrality is the main goal and circular economy is essential to achieve this target.





Figure 8-1 European Green Deal (EU Communication COM(2019) 640)

A major challenge towards climate neutrality and circular economy is the financial feasibility. To promote the application and upscaling by the market, financial instruments need to be deployed. Especially the Northern European countries already make use of a range of financial policies, such as budgets and taxes, to optimize price differences between unsustainable and sustainable products.

Another important policy instrument is public procurement. Through public procurement reward criteria's can be utilized to stimulate the contractor to make their offer more sustainable and circular. In addition, according to Witjes et al. [386] the configuration of the public procurement process should be reconsidered to succeed in sustainable business models. Instead of the process being a negotiation between buyer and seller, a form of cooperation enables to achieve the most value for both parties. Such an approach was also essential in the development process of URBCON to enable conduction of pilots with innovative materials.

### 8.2.2 Barriers

The main risks or barriers associated with upscaling of AAM binder or AAM concrete has been identified as presented in Figure 6-7, reported by producers involved in the Wool2Loop and URBCON projects. A distinction is made between barriers occurring at the different levels of the value chain. This is further divided into internal barriers, meaning obstacles the producers themselves might be able to solve, and external barriers that might be best dealt with at society level. Similarly, and with a slightly different view observed barriers have been collected mainly from the point of view of the cities (from the URBCON project) and grouped the barriers into different types (see Figure 8-3).

## KEY BARRIERS AS REPORTED BY PRODUCERS

EXTERNAL	<ul style="list-style-type: none"> <li>Lack of collection infrastructure for SRMs</li> <li>Lack of GGBFS supply in some regions and future supply decreasing</li> <li>Activators, e.g. Betol52 expensive, few suppliers and geographically concentrated</li> </ul>	<ul style="list-style-type: none"> <li>Quality of SRMs varies, in particular MWW from CDW sites</li> <li>High pre-treatment costs</li> <li>High CAPEX into investment in milling machines and other technologies</li> </ul>	<ul style="list-style-type: none"> <li>Lack of standard products, e.g. quality of input materials, mix designs and building codes</li> <li>Too time consuming to shop around for input materials</li> <li>Lack of knowledge of long term performance of the concrete</li> <li>No clear understanding of what is ecological concrete by contractors</li> <li>Permission to transport and use waste</li> </ul>	<ul style="list-style-type: none"> <li>Cost of final product needs to be in line with conventional products or only slightly more expensive</li> <li>OPC too cheap</li> <li>Takes time to convince stakeholders about new product/technologies</li> <li>Conservative market (tender material not optimised to favour green solutions)</li> </ul>
	SOURCING	PRE-TREATMENT	PRODUCTION/UPSCALING	MARKET ISSUES
INTERNAL	<ul style="list-style-type: none"> <li>Risk of availability and quality of supply of SRM</li> <li>As opposed to OPC, the quality of geopolymer binders varies from one location to another, making it difficult to market a universal final product</li> </ul>	<ul style="list-style-type: none"> <li>Considerations of in-sourcing or out-sourcing pre-treatment (in case MWW) by manufacturers</li> </ul>	<ul style="list-style-type: none"> <li>Lack of handling experience from Lab to upscaling, e.g. temperature sensitive and w/b balance</li> <li>Limited number of silos available at production site</li> <li>Geopolymers requires different additives and behaves differently from OPC</li> <li>Considerable investments in upscaling (CAPEX) in new production lines for building materials producers)</li> </ul>	<ul style="list-style-type: none"> <li>Costs concerns of contractor due to many uncertainties, as they operate under very narrow profit margins</li> <li>3-5 years time-to-market for construction and building material producers</li> </ul>

Figure 8-2 Risks or barriers for upscaling of URBCON concrete from producers' points of view

## KEY BARRIERS AS REPORTED BY THE CITIES

### Technical/Production barriers

- Lack of design regulation and design codes
- Making the paste formulas available
- Difficult to make Certification as a standard mix design
- Structural Tests is a must
- Lack of flexibility in production
- Lack of long-term performance knowledge of the geopolymer concrete
- Lack of knowledge of (potential) producers in mixing and handling the materials

### Contractor/Engineering companies

- Lack of experience by the contractors
- Costs concerns of the contractor and produces as they operate under very narrow profit margins
- Time consuming to shop around for input materials (One-stop shop could be a solution)

### CITY PERSPECTIVE

- Lack of Collaboration between the various relevant city departments
- Focus on CO2 reductions, recycling and circularity is not always the same goals
- New constructions has to go fast and does not allow for experiments
- Find possible construction partners/early movers, like the city benches to lead the way
- Align the URBCON project with the long-term goals of the City
- Communication is important to overcome barriers
- Changes takes time

### Educational barriers

- Teaching the concreting staff to work with this technology
- Clear view on safety measures through training
- Geopolymer technology not yet included in curriculum at technical education

### Availability of (local) resources and quality of SRM (Secondary raw materials)

- Unstable supply of raw materials (both GGBFS, alternative binders and activators)
- Unstable quality of raw materials
- Lack of guaranties of future supply

### Market barriers

- Convincing stakeholders to think about this technology and use it
- Reducing the amount of construction work is a better option
- OPC too cheap
- Conservative market (role of local authorities through tenders)



Figure 8-3 Risks or barriers of upscaling of URBCON concrete from cities points of view

### 8.2.3 Policy recommendations

In the framework of the URBCON project an extensive policy review has been undertaken, to understand the policy context in which the urban concrete innovation can take place [387]. The report concludes that the main drivers identified of direct importance for the URBCON concept originates from climate policies and the obligations to the Paris agreement of reducing greenhouse gas emissions by 40% in 2030 and to become climate neutral by 2050. Operationalisation of the Paris Agreement has for the EU resulted in several policies, roadmaps, and initiatives such as the Green

Deal, the Circular Economic Action Plan, etc.; all with the overall aim to reduce CO<sub>2</sub> emissions and decouple economic activity from depletion of natural capital. The report [387] provides further insights on how this is addressed at EU-, national- and local level.

The conducted policy review, combined with a study on social acceptance of eco-concrete, revealed the following recommendations. These recommendations want to overcome barriers (as opposed to already existing enablers) as identified in [387], as well as experienced during the demonstrators (Section 8.4). The main policy recommendations include:

- Encourage use of secondary raw materials, either through taxes on virgin materials, or by making LCA, carbon footprint compulsory for all building products.
- Promote use of material passport.
- Initiate measures, e.g., demonstrations to convince key stakeholders that low-carbon cement types can replace many traditional PC based applications, e.g. tiles, flooring, façade panels, etc.
- Allow new types of low carbon cements to be tested and assessed on the same terms as current PC solutions, by shifting towards performance-based building standards.
- To encourage stakeholders: architects, civil engineering, construction companies, certification schemes, etc. to consider low carbon cements through more demonstrations/reference projects, training and communication and Green Public Procurement.

In an ideal world, establishing a perfect circular economy (Figure 8-4), all materials used go back into the loop and all materials sourcing is sustainable, so is production and consumption and no waste is generated. Although this degree of circularity might be difficult to achieve, it is an important ambition, and a growing community is serious to try to approach this ideal situation. In this respect, the urban concrete innovation is one important step in that direction towards circular economy.

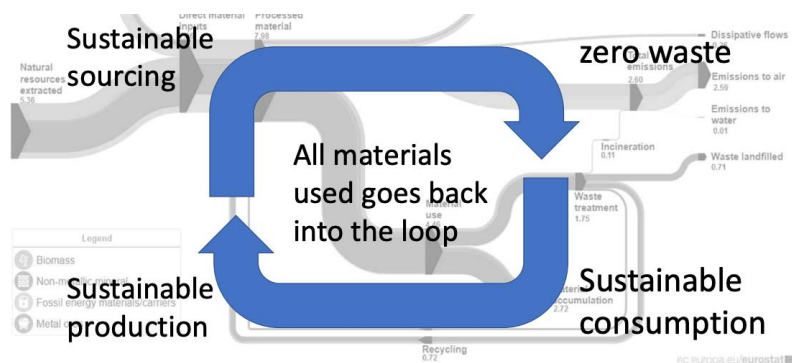

Figure 8-4 Circular economy in an ideal world

### 8.3 Tendering

Public procurement policies have growing attention to various forms of circular aspects in tendering, e.g., by adapted award criteria in more traditional forms of tenders, up to innovative tendering formats. Amongst other reference can be made to CABRIO (Circulaire Administratieve Bepalingen en Richtlijnen In Overheidsopdrachten - Circular Administrative Provisions and Guidelines in Public Procurement), that issued exemplary documents that can be used in circular tenders (<https://www.circubuild.be/nl/aanbesteden/cabrio/>). Also adapted building specifications are expected to be issued more and more, such as for example the one issued for buildings by Circubuild (<https://www.circubuild.be/nl/aanbesteden/circubestek/>). Note that these are often living documents, not yet fully including latest developments in eco-concrete. In the following sections, the

circular tendering approaches and experiences as applied in the 3 URBCON pilot projects are discussed further.

### 8.3.1 Kamp C

In the year 2019, Kamp C organized a circular tender as a preparation for the construction of the first circular building in Belgium: 't Centrum. In this structure elements of circular buildings are being integrated as much as possible. As part of the building process, together with various partners, the initiator Kamp C has set up an interesting and innovative learning process, from which the whole sector could draw some inspiration.

It is important to note that the tender considered by Kamp C for 't Centrum has been chosen for the whole of the circular office ambitions, and not specifically for the URBCON part of it. As such the tender was proven well suited to implement also URBCON concrete in the wider concept of the circular office building, and whereby at time of making the tender document the URBCON concrete part was not yet defined. At the end the URBCON concrete has been decided to be mainly used for the foundations of the circular office building, for which the circular tender had already been issued before the URBCON project started.

For the tender Kamp C has used a competition-oriented dialogue with a multiple-phase procedure. This procurement process includes four different steps (Figure 8-5): involve the market, the selection phase, the dialogue phase, and the award phase.

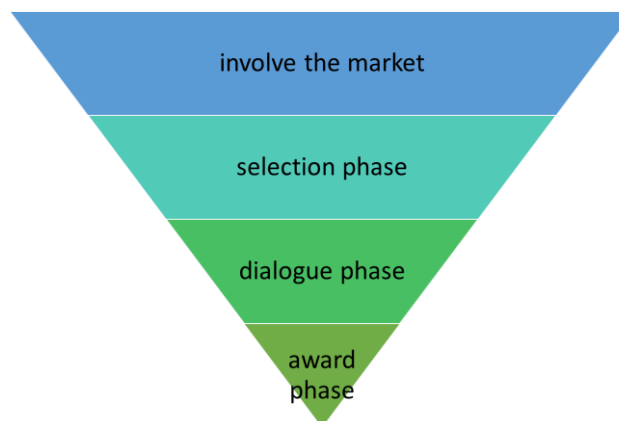

*Figure 8-5 Uncertainty associated with production of mix constituents*

The first, and very important, step for Kamp C was to involve the market. As this was not yet a well-known method of procuring, Kamp C organized various masterclasses in which interested parties were able to deepen their knowledge on circular construction, to interact and to get to know more about our specific plans on circular office building. These masterclasses covered five different topics on circularity and had the aim to arouse interest among companies. Well-known speakers on circular construction, e.g., Thomas Rau, were invited to help convince building professionals to attend the masterclasses. No entrance fee was charged. There were networking opportunities during the breaks which made it possible to form partnerships.

During the second phase, the selection phase, building teams had to register as a team. In total 7 consortia registered with a total of 50 companies. The first selection was done based on some standard “hard” selection criteria (such as certifications, financial capacity, ...) but mainly based on these qualitative selection criteria:

- An explanation of decisiveness and creativity (weighting 40%)
- An explanation of integrity (30% weighting)

- An explanation of cooperation (30% weighting)

We requested this information in the form of a written note of maximum 2000 words. By minimizing the required information in this first step we made the procurement widely accessible with minimum effort. A motivated report was written by the jury and included the names of the three building teams which were selected.

Afterwards Kamp C has organised two dialogue rounds. During these dialogue rounds the building teams were able to ask questions, bearing in mind that Kamp C as a principal would not provide any kind of evaluation or judgement on the candidate's proposal because this would compromise the level playing field. The consortia were treated the same and all got a written report with all answered questions. The remaining consortia were asked to provide a more concrete proposal based on more elaborate requirement documents and criteria. Using the criteria listed below, Kamp C chose one building team to not only design and build the office building, but to maintain it and provide energy over the next 20 years as well:

- Sketch design and integration into the environment (40%)
- Action plan (20%)
- Degree of circularity (40%)
  - Materials and resources
  - Consumption and emissions
  - Image & process
  - Health & usage
  - Financial
  - Flexibility
  - Mobility

Kamp C decided to not implement price as a criterion, rather the level of circularity (amongst the other criteria) was evaluated for a predefined overall cost price that Kamp C was willing to invest.

It is important to mention that this procedure was an intensive process for both parties. It was time consuming, and the outcome was uncertain for the building teams. We started from a very broad and holistic view on circularity. We gave the candidates a lot of freedom in approaching this topic to maximize the room for creative and innovative ideas. It turns out that this led to a lot of analysis paralysis, doubt and insecurity (e.g., should we focus more on dry connections then on re-use?). In that way we learned that, to a limited extent, a higher degree of specification or a better hierarchy in ambitions might lead to a more efficient process.

## 8.3.2 City of Ghent

### 8.3.2.1 Procedure

The city of Ghent (Belgium) chose to work with a competitive procedure with negotiation for the tendering of the fire staircase in URBCON concrete.

This type of procedure is only allowed to be used in certain cases, namely:

1. For works, supplies, or services that fall under one or more of the following situations:
  - There is no readily available (off-the-shelf) solution to meet the need
  - The works, supplies or services contain design or innovative solutions
  - The contract cannot be awarded without negotiations
  - The technical specifications cannot be defined with sufficient precision
  - Reserved contracts below the European threshold
  - Contracts below the thresholds set by the King
2. Only irregular or unacceptable bids were received in a previous open or restricted procedure



The URBCON demonstrator falls under conditions ‘innovative solutions’ and ‘technical specifications cannot be awarded defined with sufficient precision’, allowing for this type of tendering.

This procedure is a two-step procedure in which any interested economic operator may apply to participate in response to a notice. In the contract documents (e.g., selection guide and specifications), the contracting authority determines the subject matter of the contract by describing the requirements and the characteristics needed for the works/supplies/services and by setting the award criteria. It also indicates which elements of the description are minimum requirements that are not negotiable (Article 38 § 3 Public Procurement Act). This information should be sufficiently precise to allow economic operators to assess the nature and scope of the contract and decide on their participation.

The contracting authority evaluates the application for participation based on the published access requirements and qualitative selection criteria. The selected candidates are then invited to submit a tender. If the tender documents mention it, the contracting authority can limit the number of candidates invited to the procedure to a minimum of three (Article 79 of the Public Procurement Act). These tenders form the basis for further negotiations.

Negotiations can be conducted based on the initial tenders and all subsequent tenders, except for the final tender.

In terms of content, the parties are free to negotiate about everything except the minimum requirements and the award criteria. An important point here is that the contracting authority must respect the equal treatment of tenderers (Article 38 § 6 Public Procurement Act).

The negotiations can take place in various stages, provided that this arrangement is also included in the contract documents. If the contracting authority intends to terminate the negotiations, it must inform the remaining tenderers and set a deadline for the submission of an amended offer.

Besides the choice of the procedure, the city also decided to work with a building team. Only building teams could apply for the tender, consisting of at least an architectural firm, a contractor, and a stability engineering firm. This would stimulate cooperation and innovative thinking from the beginning and speeds up the planning time in the end.

### 8.3.2.2 Practise

After releasing the tender for the building team for the fire stairs at the end of 2020, at first we did not get any applications. This despite the fact, that we held a webinar for interested parties in March 2020, which got a lot of attendees and interested parties. Also, general contacts with contractors, architectural firms, and concrete producers, by asking their interest in this kind of project, resulted in mostly positive response. The low response was in this respect surprising. An inquiry was made, asking for feedback regarding the tender and why they did not apply. It seemed that, first, some of them did not see the tender appear. It was released just before the Christmas holiday, in a busy period, which made companies having other priorities. Also, some of the bigger companies, who expressed their interest at first, found the order too small for them. They would only be interested in joining a building team for bigger construction orders. Based on the outcomes of the inquiry and after sparring with the CABRIO-project (Circulaire Administratieve Bepalingen en Richtlijnen In Overheidsopdrachten - Circular Administrative Provisions and Guidelines in Public Procurement), the tender was reopened. After this second, new release, three building teams successfully applied in response of the first stage requirements of the tender.

Lessons learned:

- Timing of the release of the tender is important. Don't wait too long after an information moment. When in a busy period, pay extra attention to communication and promotion.



- Contact parties which already work with innovative products or services. Look critically at the size of your pilot and what you are asking. Is this balanced?
- Make sure you divide liability and responsibility, so this will not be kept with one party.
- Start small, grow bigger
- Ask advice from the legal department, regarding procedures and communication, to avoid future claims on being biased.

The three teams fulfilled tender criteria and have been all invited to prepare a detailed plan and offer (for which a small budget was provided to all 3 teams). As such three detailed offers were submitted, that met the selection criteria (as verified by an evaluation committee), after which the final selection process was conducted (by an assessment committee). For this, a jury was in place with members of the City of Ghent (Facility Department, Economic services, and Strategic Subsidies), FDN, Ghent University and ResourceFull. This way the offers were ranked by a group with diverse expertise. To avoid conflict of interest, jury members were asked not to have recent working connections with members of the building teams.

After a first review of the files by the jury, the building teams presented their plans live, giving the jury the chance to ask questions. This was found to be very valuable to the jury members. It made the plans more tangible and gave an idea about the enthusiasm of the teams. After the presentations, the teams got some time to adjust their plans and make a best and final offer. In the end, the teams were finally ranked, and the tender was granted to the best ranked team.

Lessons learned:

- Avoid conflict of interest when composing the jury
- We recommend having a 'live' meeting with the building team to let them present their plans
- Get some legal advice on the final selection to make sure all arguments are valid
- Make sure the jury consists of partners from different industries and with different expertise.

### 8.3.2.3 Selection and awarding

Like stated above, in a first round, building team applicants were chosen on the published access requirements and qualitative selection criteria. These criteria consist of the economic and financial capacity of the tenderer and the technical and professional capacity of the tenderer. Here, there were three building teams which all met the criteria.

After the selection of three building teams, they were asked to make a preliminary study in accordance with the specifications, and a corresponding more detailed offer. The lump-sum payment for the proposal was €10,000- excluding VAT, on condition that their preliminary study meets the requirements of the specifications, is regular and complete.

The preliminary study of the selected construction teams consisted of the following:

- a vision paper on the future development of the annex with a covered playground
- a sketch design for the evacuation staircase
- an initial cost estimate, and a description of the tasks and works to be carried out
- plan of approach
- an initial planning.

The preliminary studies received have been submitted to the evaluation committee, which checked the proposals for completeness and weighs them against the award criteria. Based on this evaluation, the contracting authority decided independently whether to move on to a negotiation phase. This negotiation and assessment phase consisted of the following steps:

- Presentation of the submitted proposals by the construction teams for the assessment committee.
- Successive negotiations with one or more regular tenderers.

- The tenderers are given the opportunity to submit a BAFO (Best And Final Offer), and if so desired, to present it.
- Weighing of the BAFOs by the assessment committee.

### 8.3.3 Municipality of Rotterdam

The tendering approach followed by Rotterdam made use of a standard tendering format, that given the relative limited size of the pilot (a pedestrian bridge of 23,3 m) allowed to make use of a running tender framework agreement to enter negotiations with a few listed bidders.

A pilot project requires all parties to expect and accept risks in time, money, and results. The URBCON pilot project would have been considered successful, even if the actual construction of the bridge in AAM concrete would not appear possible (considering instead PC-concrete as fall-back). Furthermore, unforeseen circumstances may require deviation from the preferred project plans and/or additional topics by arise that need to be addressed quickly. Therefore, it is most important to work with well suited parties. Preferably those who have demonstrated to be good partners before. The city of Rotterdam has – in the past 15 years - amassed a significant amount of experience introducing new building materials for load bearing structures. E.g., since 2009 more than a hundred FRP composite bridges have been procured and built. Such is the status of this material that in most cases, it is considered business as usual. Rotterdam has also successfully experimented with ultra high-performance concretes, modular building, structural thermal plastic material and bio-composites. Having gone through these processes, the city engineers, as well as the Maintenance Department and the Building Inspectors were all familiar with the ins and outs and what to expect. Three contractors have been pre-selected based on previous experiences. Rotterdam has contacted these parties to check for willingness and availability at the start of the URBCON project, long before actual procurement was to take place. The parties selected were all SME-sized building companies in The Netherlands (GKB Realisatie, Barendrecht, Rotterdam area; Wallaard Noordeloos, Noordeloos, Utrecht area; Van Noordenne, Nigtevecht, Utrecht area). Rotterdam used a traditional contract format in which the activities are listed, and the contract is awarded to the lowest bidder. In this case GKB Realisatie, who partnered with concrete producer ‘De Lek Beton’, from the town of Schoonhoven (NL).

Several annexes were added to provide detailed information on the nature of the project and the elements that deviated from the standard processes. Knowing the contractors and their supportive attitude there was no need for a different kind of contract, such as for example a design and built format. All parties knew what activities were necessary, and these were described in detail in the tender documents.

Normally Rotterdam would tender based on a set of technical drawings that require further detailing by the contractor. This is done because it is more cost effective as opposed to city engineers making detailed calculations. In this case Rotterdam has provided detailed calculations and drawings concerning all the concrete elements. As mentioned previously AAM does not automatically satisfy the EN 206. Test data confirmed the applicability of Eurocode 2 design rules. However, the final test results came relatively late in the process. It was determined that it would be better to fit the required timeline to use the data and perform in house engineering calculations at Rotterdam, rather than the contractor. Added benefit was that the contractor was able to focus solely on the construction phase, while not having to worry about the engineering. Additionally, in-house engineering with new material of which the contractor cannot be expected to have any knowledge relieves the contractor of responsibility. It provides a sense of shared responsibility.

One complicating factor in this project were intellectual property (IP) issues. The scientists provided the recipe and mix specification (and education) to the URBCON consortium. At this point IP became

of interest. The development of the AAM concrete mix is a very knowledge intensive process and the IP should be respected. The tender included not the specific recipe, but it explained that a new type of AAM concrete mix was to be used. The actual recipe was provided after procurement to the winning contractor. Via the tender documents the winning contractor grants the client, issued by the concrete developer, that for future (other) projects this mix will only be used with respect to the IP. The recipe was not provided beforehand to all potential contractors. This was done to reduce the risk of leaking of confidential information.

It turns out that the mix quality is sensitive to the used materials, especially the raw secondary materials. Therefore, the client exactly prescribes which material must be used by the contractor. However, in the tender phase none of the contractors were granted insight in the mixture and its underlying raw materials. So, Rotterdam as the client contacted the producers of the raw material beforehand to make sure that materials would be available, and no excessive costs would be encountered by the contractors. Thereby making sure that their tender prices would turn out to be accurate, later in the process.

Of further importance for the project was a test protocol to determine the characteristics of the AAM concrete, design the bridge and prepare the tender documents. However, the protocol was two-fold in the sense that part of it would have to be performed by the contractor, as an extra means of quality control of the built structure. This was indicated in the tender documents. The contractor was to work in three different scales. From small to large and in consecutive order these were:

1. Cubes (150 mm size)
2. Slabs (similar as in previous lab research slab tests)
3. Full scale bridge decks (proof loading on actual part of the bridge deck)

This stepped approach would allow the contractor to gain important experience handling the material before casting the definitive decks. Any problems found could be addressed timely and would not lead to a negative pilot outcome.

## 8.4 Lessons learned from the URBCON pilots

### 8.4.1 A way of documenting lessons learned from the demonstrators

In reference to [Sections 9.3 till 9.5](#), that describe the conducted URBCON pilots (also referred to as URBCON demonstrators), an excellent opportunity was provided for lessons learned and dissemination of knowledge, associated to the scale-up and usage of AAM concrete in these demonstrators and the associated implementation of the URBCON/DuRSAAM concrete family.

For each pilot a *lessons learned* analyses has been made in terms of:

- Value proposition, cost-benefit
- Evaluation
- Success factors
- Risk assessment
- Resistance, discussion points

Hereby, the different roles or stakeholders for the relevant phases of the pilots have been considered, as given in Table 8-1.

The pilots, being the cornerstone of the URBCON project, contribute significantly to the learnings of the project. The observations and learning made per pilot are reported in the following sections.

The main learnings across the pilots and during the different phases of the pilots are summarised in Figure 8-6.

*Table 8-1 Stakeholders and phases of the pilots considered for lessons learned*

Stakeholders	Pilot phases
1. Supplier	1. Mix-Design
2. Principal	2. Constructional design
3. Designer/architect	3. Supply chain secondary raw materials
4. Engineer (Constructor)	4. Permit (safety, environment)
5. Legal Authority	5. Execution (safety, environment)
6. Asset manager	6. Eco costs (mix design, construction)
7. User	7. Monitoring (long term behaviour)
8. Demolisher	8. Maintenance (damage, wear)
9. Recycler	

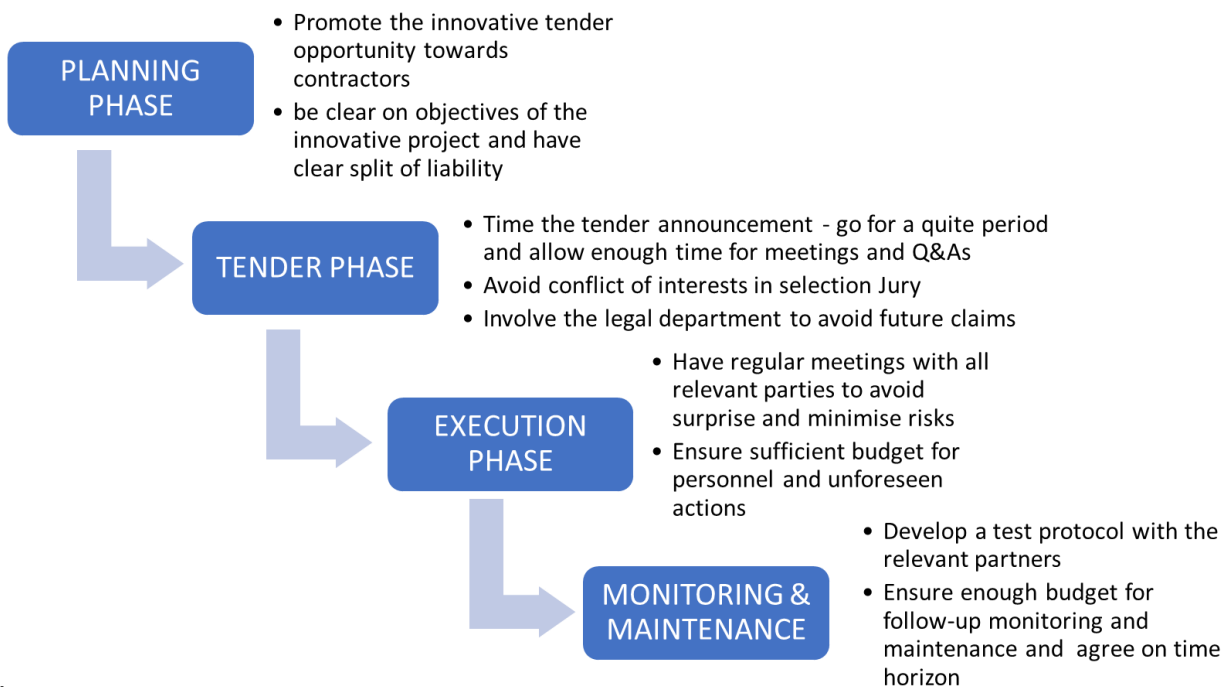

*Figure 8-6 Main lessons learned across the pilots*

## 8.4.2 Learnings from the Ghent pilot

### 8.4.2.1 Short description of the pilot and lessons learned summary

In Ghent the pilot project (Section 9.4) contains the building of a fire staircase at a primary school. At the starting point the school had no correct fire escape route for the top floors and the fire department assessed that this should be solved. Since there is also a shelter at the back of the school, the project also contains the future improvement of this shelter. The building team designing the fire escape needed to allow for this future improvement and include it in the plans.

Ghent also has performed a second pilot project, containing street furniture made with URBCON concrete. The square in front of the primary school had to be redecorated into a greener, saver square. Since the fire stairs were not intended to apply recycled aggregates, Ghent decided to do this extra pilot – street furniture with recycled aggregates.

A further discussion on the lessons learned is provided in the following sections. A summary overview is given in Figure 8-7.

**POLICIES & MOTIVATION**

- By choosing a load-bearing structure, the City hoped to promote the usage of an innovative solution and focus on circular construction
- With the Street benches, the idea has been to showcase the solution for a broader public and companies to use eco-concrete

**SUCCESS CRITERIA**

- Percentage of raw materials saved
- Pilot executed according to plan
- Results of Pilots shared and picked up by the building sector
- Showing that City of Ghent are a frontrunner in circular economy reflecting the CleanTech and climate goals
- For the street benches, additionally, that people use the benches and think positive about them

**STAKEHOLDERS**

- City of Ghent: Economic Services, Facility Department Road&Construction service and ‘Invest in Ghent’
- Ghent University (development of the mixdesign)
- Flemish government/OVAM for commodity statement of URBCON concrete
- Contractors/Building team
- URBCON project/Imerys/Resourcefull
- School children, parents and the school teachers

**BARRIERS**

Some critical aspect were experiences during the different phases

- Timing of planning among the different departments of the city
- Timing of release of the tender should be long enough to allow for Q&As
- Prompt potential contractors to make them aware of the innovative project to make it attractive for them
- Recognise that the contractor might see an innovative project as high risk, they are used to operate with very small profit margins



**LESSONS LEARNT**

- Ensure clear liability and responsibility divisions
- Involved legal department to avoid future claims
- Clear communication on objectives with the contractors once selected and regular meetings during implementation
- Start small, grow bigger with innovative projects
- Make sure budget and personnel is already being thought about beforehand

Figure 8-7 Summary lessons learned Ghent pilot

8.4.2.2 Main stakeholders

Several stakeholders have been involved in this pilot. First, there is the city of Ghent, with already different parties within its structure. There is the ‘economic services’ team who have the lead in the work package (of the URBCON project) associated to the pilot. The ‘invest in Ghent’ team focusses, amongst others, on making Ghent a cleantech capital and a frontrunner in circular economy. The URBCON pilot tendering comprised these ambitions. As landlord, there is the ‘facility management’ department, who is responsible for the city buildings, including school buildings. They have the technical knowledge about tender procedures, permit procedures, architectural aspects, ...

Next to the city, and supporting as URBCON project partners, are Ghent University and ResourceFull, who designed the mixture and paste formulation of concrete to be used for the fire staircase. They also help with the necessary testing of the mixture and setting up protocols.

The Flemish governmental organisation OVAM works on waste, materials and soil protection. They advised on the environmental safety aspects and are therefore also an important stakeholder.

The city has chosen to work with a building team. The team consisted of at least an architectural firm, a contractor, and a stability engineering firm, who are also stakeholders. The selected building team comprised Back Architects, engineering office Mouton, general contractor Furnibo and precast concrete provider Enjoy Concrete.

Besides these, the users of the school (teachers, children, and parents) are also stakeholders.

The second demonstrator is the street furniture, placed on the redecorated square in front of the school (Section 9.6.2). Stakeholders involved are the aforementioned teams (economic services, invest in Ghent, facility management) as well as the ‘road & construction’ services. The latter are

responsible for the redecoration of the square and choosing the final designs. They also provide all plans, time schedules, and appoint the contractors.

Amongst the URBCON project partners, the two other main stakeholders are Imerys, who provided the secondary aggregates and ResourceFull, who helped design the concrete mixture and conducted the necessary testing.

The manufacturer of the street furniture is of course also an important stakeholder. For this demonstrator the company Urbastyle made the furniture, and whereby it is expected that the usage of secondary aggregates for future concrete products gets picked up by more companies and users.

Other stakeholders are the road users and especially the pedestrians and school visitors (e.g., parents) waiting outside.

#### 8.4.2.3 The policies and arguments leading to the plan making of the pilot

When choosing the pilot location and structure, the city of Ghent wished to choose a location that would show the confidence the city has in these innovative concrete products. Originally, the pilot selected was the building of a new canteen at a secondary school. Along the project, it happened that this canteen needed to be replaced sooner than the URBCON project timeline had foreseen, so the city needed to choose a new pilot. This is why finally the city has chosen to go for the fire stairs. This fitted the timeframe of URBCON and still fitted the goal of showcasing the cities ambitions regarding circular economy and the usage of secondary raw materials. The fact that the shelter also needs replacement soon, along with the aspiration of using innovative tender procedures, made the city choose for working with building teams. This way, the building team was asked to already include the plans for the shelter and work together from the start in this innovative pilot project – which allowed to shorten the implementation phase later.

The building team was requested to design the fire staircase in precast elements. This would shorten the time that the contractor and builders need to be on site (no concrete pouring needed), which will be better in relation to the presence of the children at the school and the nuisance caused. It would also provide lessons learned regarding the use of precast elements in URBCON concrete and the production of these in the concrete factory. It also allowed to pay more attention to demountable construction formats as one of the principles towards more circular construction.

Since it was opted to not use recycled aggregates in the concrete for the fire staircase, by enlarge a second, smaller pilot project nearby the school was decided, containing of street furniture. Besides the benefit of being able to showcase two types of URBCON concrete in our city, for two different applications, there is also the benefit of visibility from the street furniture. This will be placed on public domain and free to be used by civilians and people passing by. This in contrast to the fire staircase, that is placed at the back of the school building and less visible from the street, but still accessible given the public function of the school.

#### 8.4.2.4 The perspective of implementation, in case of success of the pilot

With choosing a load-bearing structure, the city hoped to give the necessary publicity to the usage of innovative concrete products. Within the facility management department, a framework for asset management is being made, focusing on circular building, the usage of circular and innovative materials and the reuse of materials. The lessons learned from the URBCON pilot will provide valuable input for this and will hopefully speed up the implementation. The city wishes to play an exemplary role as a public authority.

Besides this, the city also hopes that the building sector will pick up more and more on these innovative materials. For this, the necessary standards and regulations are an important factor. So, future focus will also be needed more on policy and standardization, to persuade companies and citizens to make use of these products.



With the usage of URBCON concrete in a more user-friendly application, like street furniture, the city expects to gain the interest from public services and companies working in the public domain to start using more eco-concrete in the future. It demonstrates to these stakeholders that this concrete type is just as save and user-friendly as normal concrete and is also aesthetically pleasing. Its qualities on sustainability will not be inferior to normal concrete, at the contrary.

#### 8.4.2.5 The criteria to determine the success of the pilot

The following criteria have been applied to assess the success of the pilot and were found mostly achieved.

Fire staircase:

- Percentage of raw materials saved, and CO2 reduced.
- Pilot executed within the foreseen time frame.
- Results of pilot are shared and picked up by building sector, enough promotion and communication being spread.
- Shows the city of Ghent as a frontrunner in circular economy, in reference to ambitions in CleanTech and climate goals.

Street furniture:

- Percentage of raw materials saved, and CO2 reduced.
- Pilot executed within the foreseen timeframe.
- Results of pilot are shared and picked up by building sector, enough promotion and communication being spread.
- People use and visit the street furniture, residents think positive about it.

#### 8.4.2.6 Value proposition, cost-benefit

The value proposition consists of the contribution to climate goals, to circular economy, clean technology, and the reduction of CO<sub>2</sub>-emissions. Extra costs of the pilot are part of the learning process.

#### 8.4.2.7 Critical aspects in the different phases

##### **With respect to plan making**

The city of Ghent experienced some difficulties in the planning phase of the pilot, that provided us with valuable lessons. First, like mentioned above, it was originally planned to build a new canteen at a different school in Ghent. Those plans were made when writing the project, and in the end, it became clear that the pace of this building project and the URBCON project were not the same. When choosing a new project as pilot, it was also hard to find one that fitted the timeframe of URBCON. The facility management department has its specific timeline for renovations of (school) buildings and there is also the timing of the fire department, for whom the fire safety is priority. So, a lesson learned here is that for a public authority, extra attention needs to be paid to aligning between different departments and services and their different interests.

After releasing the tender for the building team for the fire staircase at the end of 2020, originally no applications/bids were received. This despite the fact, that a webinar was held for interested parties in March 2020, which got a lot of attendees and interested parties. Also contacts with some contractors, architectural firms, and concrete producers, confirmed that they would be interested in this kind of project. So, the city was surprised to get such a low response on the official tender.

Afterwards, feedback regarding the tender was collected. It seemed that some of them did not see the tender appear. It was released just before the Christmas holiday, in a busy period, which made companies forget about it after the holidays or not notice it. Also, some of the bigger companies,

who expressed their interest at first, found the order too small for them. They would only be interested in joining a building team for bigger construction orders.

Further advice was also given by the Flemish government, through the CABRIO-project (Circulaire Administratieve Bepalingen en Richtlijnen In Overheidsopdrachten - Circular Administrative Provisions and Guidelines in Public Procurement) regarding the tender and the reasons why it didn't get any response initially.

All in all, there was sufficient confidence to reopen the tender again. After this second, new release, three building teams applied for the tender.

#### *Lessons learned for the fire staircase:*

- Timing of the release of the tender is important. Don't wait too long after an information moment. When in a busy period, pay extra attention to communication and promotion.
- Contact parties that are already working with innovative products or services. Look critically at the size of your pilot and what you are asking. Is this balanced?
- Make sure you divide liability and responsibility, so this will not be kept with one party.
- Start small, grow bigger.
- Ask advice from the legal department, regarding procedures and communication, to avoid future claims on being biased.

The plan making phase for the street furniture was fortunate enough not such a hassle. The city informed with their colleagues from the construction & roads services, about any upcoming plans for new street or park furniture and luckily enough, the square in front of the school was planned to be redecorated.

Off course there were some questions regarding safety and costs, but these doubts got to be taken away soon. ResourceFull showed the colleagues with examples and test results that the usage of these hybrid alkali-activated binders and secondary aggregates in street furniture is perfectly safe and feasible. Because the pilot is subsidized by the Interreg program, extra financial costs for implementing the new concrete technology as a demonstration, were covered by the URBCON project. Since the square was planned to be redecorated anyway, the costs for street furniture were already calculated.

#### *Lessons learned for the street furniture:*

- Make sure you explain the goal and method of the using of the innovative concrete thoroughly to the people that you want to persuade.

### **With respect to decision making**

After the application of three building teams the process of jurying these applications started. For this, we composed the jury with members of City of Ghent (Facility Department, Economic services and Strategic Subsidies), FDN Engineering, Ghent University and ResourceFull. This way we had a diverse group of expertise. Since the professor of Ghent University working for URBCON also had connections to members of the building teams, we asked an independent professor to be jury member, to avoid conflict of interest.

After a first review by the jury, we asked the building teams to present their plans live, giving us the chance to ask questions. Those moments were found to be very valuable by the jury members. It made the plans more tangible and gave an idea about the enthusiasm of the teams. It already became clear very soon that one team was least favorite, and two teams were equivalent.

After the presentations, the teams got some time to adjust their plans and make a best and final offer. In the end, the decision between the two best teams was a close call.

#### *Lessons learned for the fire staircase:*

- Avoid conflict of interest when composing the jury.
- We recommend having a 'live' meeting with the building team to let them present their plans.
- Get some legal advice on the final selection to make sure all arguments are valid.
- Make sure the jury consists of partners from different sectors and with different expertise.

#### *Lessons learned for the street furniture:*

- Much smaller assignment, so it was enough to write to three producers for a bid, considering price and expertise. Urbastyle won the offer.

### **With respect to the execution**

#### *For the staircase:*

- Regular building team update meetings are important for everyone to keep track. Since it is a pilot project, lessons learned need to be kept track of, which can be hard for external parties. This is being provided by the protocol, made by FDN as a project partner. This provides a framework and designates responsible persons.
- Planning of the building process is muchly dependent on the mix design and has been finetuned a few times. When working with new materials, it is important to calculate enough time for changes and delays.
- For the fire stairs, the original mix design was abandoned after June 2022, because of an unexpected issue during the upscaling (whereby the treatment of one of the by-products appeared partly incomplete). The mix design was replaced by two other mixtures, still within the URBCON family.
- Given the needed lead time of the demonstrator felt within a period of increase cost price of building products (high index rates in society), the cost appeared somewhat larger than originally intended.
- Timing within a European project is proven to be difficult to align with the schools wishes. The preparatory works (e.g., foundation) and placing of precast elements itself will cause quite a bit of noise and traffic. Since the 'Zonnepoort' is a school for special needs children, the school management to adapt the building periods to school holiday periods and to minimize the impact on the daily functioning of the school.

#### *For the street furniture:*

- Execution went as planned, and the placement was done even faster than expected. Urbastyle produced the street furniture, which was transported by the city of Ghent roads & traffic department and placed by their workers as well.
- There was a press moment and official opening in November 2021, together with the involved URBCON partners, Urbastyle and city services. Despite the gray weather, this was quite a success and attracted positive response. The same can be stated about the opening and showcasing events conducted Spring 2023 on the fire staircase.

### **With respect to monitoring and maintenance**

A test protocol is being made for the URBCON concrete mixture that will be used for the stairs and the street furniture. Project partner FDN provides an extended protocol, going over the different phases of the building process, including monitoring afterwards. By following these steps and keeping track, it is easier to document pros and cons afterwards.

The protocol is being discussed with the building team and SECO as a control company. The more partners involved, the harder it is to get to decisions and the more important it is to follow up in time. The protocol can exactly do this, but it needs to be verified by all partners.

The protocol is being followed up every two building team meetings, checking if everyone fills this in alright and seeing if any problems/questions arise. In the end, this document will serve as a checklist and tool for future similar project, as well to keep the URBCON project results specific to the pilot well documented.

For the fire stairs, monitoring will be done on a few specimens (including cubes), made in URBCON concrete, and placed nearby. This way, several qualities of the concrete can be followed up upon in time, by strength measurements, as well as visual inspection.

Also, the different stakeholders from the street furniture production have been asked for their input and lessons learned, and this feedback has been integrated in the protocol for the street furniture project in front of the school.

*Lessons learned (mainly from the fire staircase):*

- Make sure budget and personnel is already being thought about beforehand.
- Involve all parties from the beginning so unexpected surprises afterwards are reduced.
- Monitoring will go on long after project ends, think about financing beforehand.

### 8.4.3 Learnings from the Westerlo pilot

#### 8.4.3.1 Short description of the pilot

In the year 2019, Kamp C at Westerlo organized a circular tender as a preparation for the building of the first circular office building in Belgium: 't Centrum. In this building as much as possible elements of circular building are being integrated. As part of the building process, the initiator Kamp C, together with lots of partners, has set up an interesting and innovative learning process, from which the whole sector could put some inspiration.

The foundation blocks and beams of the building are made of URBCON-concrete. These are being produced by means of prefabrication in standard sizes, whereby they are perfectly demountable and reusable in new projects. Also, the floor of the lift shaft is made with URBCON-concrete, in this case making use of ready-mix concrete. In the exterior layout around the building, it was also decided to work with URBCON-concrete. The choice was made for paver blocks that are prefabricated in the factory and that largely consist of URBCON-concrete. Note that different URBCON mix designs have used. For a further description of this demonstrator at Westerlo, reference is made to [Section 9.5](#).

A further discussion on the lessons learned is provided in the following sections. A summary overview is given in Figure 8-8.

#### 8.4.3.2 Main stakeholders

Under the direction of ResourceFull and with the support of UGent, a test program was initiated for the development of a suitable concrete mixture for the foundations of 't Centrum with the least possible environmental impact. The research started with the development of sustainable binders based on industrial residues. In the lab, therefore, we worked hard to find the right combination of raw materials and chemical activators. At mortar level, properties such as tensile and compressive strength, flow and shrinkage were examined. In the concrete labs, the mixtures were scaled up based on the material and concrete properties of the intended application. The granular skeleton was optimised with an in-house developed gasket model using the available sands and aggregates from the producer.

Based on the tests on fresh concrete (flow, flow stability, curing time), on cured samples (compressive strength, shrinkage, density, E-modulus) and on durability (freeze-thaw, resistance against carbonation, chloride penetration), equivalence could be demonstrated with the two traditional mixtures: (i) C20/25 EE2 S5 and (ii) C30/37 EE3 ZVB.

#### POLICIES & MOTIVATION

To demonstrate and gain interest from the building sector in building with eco-friendly concrete as part of the construction of the first absolute circular office building in Belgium.

#### LESSONS LEARNT

- We can achieve properties equal to or exceeding traditional concrete
- We can implement URBCON concrete in existing (concrete) facilities
- We can convince production to start using alternative binders
- The KampC Pilot has replaced 30 tons of raw material by secondary materials. By using the URBCON concrete composition in the foundation blocks, 22,640 kg of secondary raw materials has been used, saving 13,000 kg CO<sub>2</sub> compared to the use of traditional concrete foundations.

#### SUCCESS CRITERIA

- The process of making the supplier enthusiastic for joining the project;
- Trust in the partner Resourcefull
- Percentage of raw materials saved
- Pilot executed within the foreseen time frame
- Results of pilot are shared and picked up by the building sector
- Costs of production
- Time needed for curing of the material

#### STAKEHOLDERS

**Supplier** → The supplier has to be open for development of new types of concrete in current infrastructure. The suppliers contacted were very happy to cooperate and had trust in partner Resourcefull to join in the story of developing a sustainable concrete.

**Principal** → **Kamp C**, has the ambition to choose for a more sustainable product. The ambitions are getting even stronger, due to the URBCON project and KampC is inspired to build without cement in the whole building 't Centrum.

**Designer/architect** → Within the Kamp C pilot the architect is a member of the KampC consortium. The architect has introduced the modular development of the building, with demontable foundations which are also reusable (with retention of the value)

**Engineer (Constructor)** → Within the Kamp C pilot the engineering office and the constructor are members of the consortium. They want to obtain a building with as many circular materials as possible but they need to have the same properties as the classic concrete

**User** → After the finalization of 't Centrum, Kamp C and some consortium members will locate their offices in the office building. They want to have a very good building. Good for the people but also good for the environment.



Figure 8-8 Summary lessons learned Westerlo pilot

The production of the foundation blocks was carried out at Willy Naessens Construct in Oudenaarde. Since the raw materials were already available in the silo, the implementation of the developed eco-binders was limited to the digital adjustment of the mixing ratios and the manual dosing of the ResourceFull activators (15 - 40 kg/m<sup>3</sup>). The mixtures had a fluidity of 60 minutes, which is more than sufficient in a precast production environment. After a final quality control, all foundation elements were approved and successfully installed by Beneens in Westerlo. Finally, 6 m<sup>3</sup> of fresh eco-concrete was delivered from the ready-mix concrete plant J. Janssens & Zonen in St.-Lenaarts. By using the URBCON concrete composition in these foundation blocks, 22,500 kg of secondary raw materials could be used and 13,000 kg less CO<sub>2</sub> was emitted compared to the use of traditional foundations.

Concrete pavers were laid in the exterior construction around the building, which are made of 90% URBCON concrete. The tests showed that de-icing salts that could get on the paver blocks can have a negative influence on the concrete under freeze and thaw conditions. To avoid this risk, a protective layer was provided in classic cementitious concrete. However, this is only the top layer of 1 cm of the paver. With this method, URBCON concrete is used where possible, and we choose a safe solution as top layer. This method reduces a considerable amount of about 60% of CO<sub>2</sub> emissions.

The consortium of 't Centrum existed of professional building companies as a contractor, an architect, an engineering office, etc. Furthermore, local authorities, educational institutes, citizens, concrete suppliers, a mix designer (ResourceFull) were some of the stakeholders.

#### 8.4.3.3 The policies and arguments leading to the plan making of the pilot

When writing the project plan it was already a dream of Kamp C to implement URBCON within 't Centrum. Because of both projects' ambitions these projects go hand in hand and complement each other perfectly. The URBCON project fitted the timeframe of 't Centrum and the consortium of 't Centrum agreed to implement URBCON into the office building and in the exterior layout around the building.

#### 8.4.3.4 The perspective of implementation, in case of success of the pilot

With the showcase of 't Centrum, Kamp C hopes to gain interest from the building sector and hopes to show them that using eco-friendly concrete is possible and easy. In this way Kamp C would like to speed up the implementation of innovative concrete products.

#### 8.4.3.5 The criteria to determine the success of the pilot

The following criteria have been applied to assess the success of the pilot, in terms of success factors, risk assessment, perceived resistance, and stakeholder aspects.

##### **Success factors:**

- The process of making the supplier enthusiastic for joining the project.
- Trust in the partner ResourceFull.
- Percentage of raw materials saved.
- Pilot executed within the foreseen time frame.
- Results of pilot are shared and picked up by the building sector.
- Costs of production.
- Time needed for curing of the material.

##### **Risk assessment:**

Technical risks should be minimum, due to the extensive testing of the URBCON mixtures in the project.

##### **Discussion points/resistance:**

The implementation of URBCON in 't Centrum went very smooth. There were no barriers or struggles to consider.

##### **Stakeholder aspects:**

1. Supplier → The supplier must be open for development of new types of concrete in current infrastructure. So far, within the Kamp C pilot the suppliers contacted were very happy to cooperate. The trust that the supplier has in partner Resourcefull has meant that they were able to join in the story of developing a sustainable concrete.
2. Principal → Kamp C, the principal must have the ambition to choose for a more sustainable product. The ambitions are getting even stronger, thanks to the URBCON project the consortium is inspired to build without Portland cement in the whole building 't Centrum.
3. Designer/architect → Within the Kamp C pilot the architect is a member of the consortium. The architect has introduced the modular development of the building, with demountable foundations which are also reusable (with retention of the value).
4. Engineer/contractor → Within the Kamp C pilot the engineering office and the contractor are members of the consortium. They want to obtain a building with as many circular materials as possible, but they need to have similar properties as the classic concrete.
5. Legal authority → Limited role, the permit was for the whole building.
6. User → After the finalization of 't Centrum, Kamp C and some consortium members will locate their offices in the office building. They want to have a very good building. Good for the people but also good for the environment.
7. Demolisher → Very limited role, as the foundation members (as well as a major part of the rest of the building) are demountable and reusable. The paver blocks are also 100% reusable.
8. Recycler → Standardized foundation members and paver blocks are reusable in other projects.



#### 8.4.3.6 Value proposition, cost-benefit

The target of this pilot is the replacement of some 30 tons of raw material by secondary materials. By using the URBCON concrete composition in these foundation blocks, 22,640 kg of secondary raw materials could be used and 13,000 kg less CO<sub>2</sub> was emitted compared to the use of traditional concrete foundations. The cost-benefit has not been explicitly calculated.

To reach the goal, but also in alignment with the entire Kamp C philosophy, Kamp C wanted the outdoor layout of 420 m<sup>2</sup> to be produced in URBCON pavers. By doing this an extra of 9,600 kg secondary raw materials could be used. Based on the preliminary LCA-studies about 60% of CO<sub>2</sub> has been saved (= 4,500 kg of CO<sub>2</sub>).

#### 8.4.3.7 Critical aspects in the different phases

Throughout the different execution phases, associated to the concrete part of the building, mainly the good collaboration between the specific stakeholders at that point was experience of great value:

1. Plan making → Together with ResourceFull.
2. Engineering → Together with STRENG-TH (engineering office of 't Centrum).
3. Decision making → Kamp C together with the consortium of 't Centrum.
4. Execution → Cooperation with ResourceFull, the consortium of 't Centrum and the different concrete suppliers.
5. Monitoring and maintenance → Minimal monitoring in the foundation members. An extra foundation block was placed above ground as a show case. The paver blocks will be monitored by visual inspection.

*Lessons learned:*

- We can achieve properties equal to or exceeding traditional concrete.
- We can implement URBCON concrete in existing (concrete) facilities.
- We can convince production to start using alternative binders.

### 8.4.4 Learnings from the Rotterdam pilot

#### 8.4.4.1 Short description of the pilot

The municipality of Rotterdam is responsible for the maintenance of hundreds of pedestrian bridges. Each year, a serious number of them are being replaced by new bridges. The challenge was to use one of the planned park bridge replacements as a pilot for sustainable concrete. For a further description of the pilot, reference is made to [Section 9.3](#).

The dilemma for the pilot was: how to tender a bridge in alkali-activated concrete (or geopolymer concrete) without knowing how to judge the proposals, because of the lack of relevant technical knowledge on the side of the client? It's not difficult to ask for a replacement of primary materials or for low environmental costs (eco-costs) from a structural viewpoint. For a load bearing element in alkali-activated concrete, however, less advanced systemic knowledge and experience is available. This requires starting from the development of a case specific concrete recipe and an associated test plan. Many tests are being carried out throughout The Netherlands and surrounding countries, but the necessary systemic knowledge remains unavailable, requiring further testing specific to the intended pedestrian bridge. URBCON gave the opportunity by – taking a small step back – to holistically produce the right and complete knowledge. Thereby greatly reducing the current obstacles to apply alkali-activated concrete on a large scale. Large scale application is necessary for alkali-activated concrete to be able to have a significant effect on sustainability aspirations.

A further discussion on the lessons learned is provided in the following sections. A summary overview is given in Figure 8-9.

#### POLICIES & MOTIVATION

- Policy ambitions
- Reduce CO2 emission by 50% by 2030
- Reduce use of primary materials by with 50% in 2030

#### BARRIERS & REFLECTIONS

- Difficult directly to compare environmental results of the URBCON compared to conventional concrete since LCA does not really take circularity of materials into account
- Recycled materials often has a higher footprint than virgin materials impacting both costs and LCA results
- URBCON has been a really good learning experience and shows that we can cut back on using traditional concrete in the future. However new mix designs needs to be developed to take account of available local secondary materials.

#### SUCCESS CRITERIA

- Creation of a safe bridge within time and budget that meets requirements of Asset Management.
- Successful monitoring to further technical knowledge
- Building a successful showcase around the pilot
- Reduction of CO2 emissions for the bridge compared to a conventional concrete bridge
- Lower ecocosts for the bridge for the bridge compared to a conventional concrete bridge

#### STAKEHOLDERS

The primary stakeholders are:

- Rotterdam Engineering Office
- Rotterdam department of Asset Management
- Rotterdam Building Regulatory Department
- Rotterdam City Design Department
- Local Water Authority
- Local residents and the Rotterdam population at large

#### LESSONS LEARNT

- The timelines for pilot projects are susceptible to delays
- Working with familiar contractors is key to success
- Introducing a new material is time, knowledge, and money intensive
- All involved parties should be on board for the greater good that is being pursued
- Permit departments need to be consulted as early as possible
- Robust design and robust assumptions at the start of the project reduce the change of failure
- Take nothing for granted when working with a new material just because it seems similar to conventional material
- Design by testing is unavoidable



*Figure 8-9 Summary lessons learned Rotterdam pilot*

#### 8.4.4.2 Main stakeholders

The primary stakeholders, from the perspective of the Rotterdam Engineering Office, are:

- Rotterdam department of Asset Management
- Rotterdam Building Regulatory Department
- Rotterdam City Design Department
- Local Water Authority
- The contractor and concrete precast company
- Residents and the Rotterdam population at large

The Rotterdam Engineering Office, which was primarily responsible for the realization of the pilot bridge has contacted Asset Management to come up with a suitable project. Asset Management has a yearly renewal program. The bridge Slaghaam was scheduled to be replaced due to its technical state. Therefore, Asset Management became our client. For the client three main requirements needed to be met: (1) within existing financial and time constraints; (2) life span in concordance with regular concrete; and (3) safely and functionally available during the life span.

The process involved to construct the bridge was highly knowledge intensive and somewhat inefficient. This has to do with lack of technical expertise on the side of the engineers but also the fact that AAM concrete does not adhere to established technical norms. Fortunately, most of the extra costs associated with the project were covered by the URBCON project. These costs mostly stem from laboratory testing of the material to determine its characteristics. During the tender procedure it was found that the costs of the actual construction of the bridge did not differ significantly from regular concrete.

To maximize the lifespan of the bridge several design alterations have been done. Some anomalies became clear from the tests (in comparison with regular cementitious concrete). More sensitivity to creep and frost-thaw was observed. Consequently, the bridge design has been adjusted (shape that compensates for creep deformation, sealing of the upper sides, short spans and increased concrete

cover). This only leaves long-term behaviour as an unknown factor. Monitoring equipment has been installed, which enables Asset Management to verify structural behaviour in the future as well as measure creep deformations.

During the year 2020 it turned out that the two appointed pedestrian bridges, that Asset Management initially had selected, were not available any more for the URBCON pilot project due to time issues, similar to what has been the experience for the Ghent pilot. The laboratory test phase had suffered delays due to the Covid pandemic closures. The Slaghaam bridge was selected as an alternative pilot object. This, however, did not come without consequences as this bridge was much larger than the previous bridges. Some design alterations were necessary, as mentioned above.

The Building Regulatory Department was to provide the building permit. Consultation with them was established very early in the process. This enabled the project team to prepare the permit application in such a way as to have no delays later in the process. Material test reports were shared and a special full-scale test up to 120% design load was performed and reported.

The City Design Department deals with the overall look and feel of the city. For the Rotterdam pedestrian bridges, several design families have been set up. The pilot bridge falls in one of these families. However, extra supports were necessary, deviating from the original family design. These alterations have been designed with the assistance of the architect. His support for the deviations again inhibited delays in the building permit process. This is because City Design is also involved in Building Regulatory Department.

When it came to the Water Authority two aspects became of interest. One is the application of supports under the bridge. This was a consequence of using the new material, for which it was opted in terms of risks to use limited span lengths. The Water Authority seemed hesitant to allow these supports, because of reasons of aesthetics as put forth by Rotterdam, despite that these supports were requested earlier in the process. The second aspect is leaching. It is important that new materials do not introduce unknown or excessive contaminants in the water system that would degrade the water quality. A leaching test was performed. No problems were found. Thus, the water permit was received.

#### 8.4.4.3 The policies and arguments leading to the plan making of the pilot

Conforming to the Paris Agreements, The Netherlands has a national policy on sustainability. The municipal board of Rotterdam has decided on a local policy on sustainability and circular economy, written down in the agreement 'New energy for Rotterdam'. The goals are to reduce the amount of dispersed CO<sub>2</sub> (with 49% compared to 1990) and to reduce the purchasing and use of primary materials (50 % of the total by 2030). The program 'Rotterdam Circulair' aims to put these ambitions into results, to involve the stakeholders and to scale up the circular economy. Also, to stimulate all stakeholders, both public and private, to reduce the production of CO<sub>2</sub> and to lower the use of primary materials, the URBCON project is a first step in a transition on building materials, including concrete on a material level. The pilot is part of the strategy to demonstrate and communicate on inspiring projects.

Because of national ambitions Rotterdam had to make sure that the CO<sub>2</sub>-footprint of both envisaged URBCON mixtures would not exceed the footprint of the conventional concrete used for such an application (concrete based on CEM III/B). The conventional concrete uses blast furnace cement, as usual in The Netherlands. This needs to be verified because of the verdict of the Dutch Court in the case of the Urgenda foundation. Research company NIBE has performed the LCA, to determine the CO<sub>2</sub>-footprint and the environmental costs (ECI) of the different mixtures. Conclusion was that both two URBCON mixtures available to Rotterdam by TU Delft perform significantly better than the conventional concrete based on CEM III/B.

Interestingly, the mixture with higher circularity using recycled aggregates has a slightly more negative impact on the environment. It must be noted that LCA-calculations on the environmental impact do not automatically take the benefits of circularity into account. To consider circularity performance added parameters are necessary. A higher number of secondary aggregates also has a drawback on the properties and the client deals with the trade off in this decision.

#### 8.4.4.4 The perspective of implementation, in case of success of the pilot

Rotterdam considers its participation in the URBCON project very worthwhile, no matter the degree of success of the pilot. Though all the pilot goals in terms of the realisation of the bridge have been met. The URBCON project is about the development and gaining knowledge of alkali-activated concretes and overcoming barriers for the implementation in the society of such construction materials. The URBCON project covers a great variety of potential alternative concrete mixtures which have not all been considered within the constraints of the pilot project. Although none of the proposed mixtures solely fulfils the future needs of the concrete industry due to the lack of the specific required raw (secondary) materials. There is simply too much concrete being used in our society. Most valuable to Rotterdam is the knowledge on how to approach and implement alkali-activated concretes for actual structural projects. However, Rotterdam as a governmental organization will not actively pursue for the creation of new types of mixtures, Rotterdam in its role as client will increasingly tender for solutions with more strict environmental footprints. The URBCON project has provided insight and verification methods in key issues and parameters that play an important role in (structural) quality and performance of alkali-activated concretes. The Rotterdam pilot project shows the contours of the future tendering and verification process of structural projects with alkali-activated concretes.

Not only Rotterdam, but all project partners, especially the contractors are very pleased with the project and the result. One of the goals of the project was to provide SME businesses with a change to gain experience in the hopes to further stimulate the adaptation of AAM for structural purposes. This goal has also been reached as the concrete factory obtained permission from its shareholders to put in effort to further develop applications with AAM mixtures.

#### 8.4.4.5 The criteria to determine the success of the pilot

The following criteria have been identified:

- Creation of a safe bridge within time and budget that meets requirements of Asset Management.
- Successful monitoring to further technical knowledge.
- Building a successful showcase around the pilot.
- Reduction of CO2 emissions for the bridge compared to a conventional concrete bridge.
- Lower eco costs for the bridge compared to a conventional concrete bridge.

#### 8.4.4.6 Value proposition, cost-benefit

No cost benefits are expected. This is because there is no guarantee that the bridge will reach it's required lifespan of 50 years. If it does not meet this service lifespan the LCC-costs will skyrocket. The benefits should be sought in terms of sustainability.

#### 8.4.4.7 Critical aspects in the different phases

Throughout the different execution phases, the following aspects have been perceived as of large importance:

- The completeness and execution of the test plan.
- Correct interpretation of the results.
- Overcoming technical challenges posed by the mixture.
- Getting a good contractor on board timely.

- Making sure there is a concrete producer willing to deliver the mixture.
- Successful test of a deck for the building permit.

*Lessons learned:*

- The timelines for pilot projects are susceptible to delays.
- Working with familiar contractors is key to success.
- Introducing a new material is time, knowledge, and money intensive.
- All involved parties should be on board for the greater good that is being pursued.
- Permit departments need to be consulted as early as possible.
- Robust design and robust assumptions at the start of the project reduce the change of failure.
- Take nothing for granted when working with a new material just because it seems similar to conventional material.
- Design by testing is unavoidable.

Note that many of the above-mentioned lessons are like previous experimental driven pilot projects, such as the implementation of FRP bridges and UHPC concrete.

## 9 APPLICATIONS

### 9.1 Introduction

AAM concrete is emerging the last decade, though it should be noted that this technology has a longer tradition of applications, that dates to 1960. The reason for the renewed and increased interest in AAM concrete goes hand in hand with the increased emphasis towards a more carbon neutral building industry. In this chapter an overview is given of multiple historical applications, as well as the large-scale demonstration projects that have been successfully conducted during the URBCON project.

### 9.2 Review of existing applications before the URBCON/DuRSAAM projects

Beside lower CO<sub>2</sub> emissions, alkali-activated materials (AAMs) represent a possible alternative binder to Portland cement (PC), due to their high performance. Although there is a general agreement about the benefits AAMs bring to the concrete compressive strength, on their durability debates are encountered, limiting their large-scale application. However, several examples of the durability of AAM can be found in construction works and buildings, still existing in different countries around the world.

The earliest known applications of alkali-activated concretes date back to the 1960s and these constructions confirm the high performance of AAMs, durability and chemical resistance [388]. In the following a non-exhaustive overview is given of AAM concrete developments over the years and in different regions. Note that this information is only intended for inspirational purposes, without the ambition to be complete.

#### 9.2.1 Adoption of alkali-activated blast furnace slag concrete

Thanks to Purdon's work, not only blast furnace slag was activated with sodium hydroxide in 1940 [389], but also the production of alkali-activated concrete was commercialised and distributed in Brussels in the 1950s under the trade name Le Purdociment [390]. This new kind of cement was composed of more than 90% blast furnace slag activated with sodium sulphate (Na<sub>2</sub>SO<sub>4</sub>) and calcium hydroxide (Ca (OH)<sub>2</sub>) and with a small amount of Portland cement or lime [391].

Several buildings were built between 1952 and 1959 using Le Purdociment [391]. The information related to these buildings were collected thanks to archives, SOFINA's archives, the main shareholder of Le Purdociment and the company where Purdon first worked as a researcher [391]. As shown in the following table (Table 9-1), this type of alkali-activated slag concrete suffers of carbonation, though the actual strength is higher than the design one [391].



*Table 9-1 Applications of Le Purdociment in the construction field*

Project	Year	Material	Actual conditions
"Parking 58" building	Second half of the 1950s (The first six levels)	Le Purdociment	Damage on slopes, floors and the roof. "Bad or missing concrete treatment and curing led to erosion problems" (Archives of SOFINA)
Factory "Delle"	1957	Le Purdociment, ground floor	Structure well preserved. Leakages led to disintegration of the concrete structure
The Royal Building	Completed in 1963	No information related to the type of cement used	Inside: still intact Outside: balconies show carbonation-initiated corrosion

Next to Belgium, alkali-activated slag concrete-made construction works found place in the former USSR (1922-1991) (Table 9-2), where local iron production facilities provided blast furnace slags and activators could be sourced locally [390].

*Table 9-2 Alkali-activated slag concrete application examples in the former USSR*

Project	Year and place	Material	Additional information/Actual condition
Residential buildings			
2-storey and 15-storey residential buildings	1960 – 1980, Mariupol, Ukraine	Alkali hydroxide activated BFS pre-cast blocks and hemiblocks	
24-storey building	1986 – 1994, Lipetsk, Russia	Alkali carbonate activated BFS concrete (w/b 0,35; Quartz sand and dolomitic limestone as aggregates)	Exterior walls cast-in-situ and floor slabs, stairways and other structures pre-cast and steam cured (25 MPa). Inspected in 2000, compressive strength of 32-37 MPa, no cracking, deterioration, or defects on the surface.
Industrial buildings			
Storehouse	1974, Krakow, Poland	Precast steel-reinforced alkali-carbonate activated BFS concrete (Floor slabs and wall panels)	Cast and cured in hot air at 70° C for six hours in a heating tunnel. After more than 25 years, compressive strength doubled, carbonation < 0.5 mm/year
Concrete pavements			
Heavy duty road to the Magnitnaya mountain quarry (concrete pavement)	1984, Magnitogorsk, Russia	95% ground granulated BFS, 5% Portland cement, w/b 0.35	After 15 years, compressive strength of 86.1 MPa (design strength 30 MPa), carbonation < 1 mm/year
Concrete road (330m long x 3-4m wide)	1984 – 1990, Ternopol, Ukraine	Alkali-activated BFS concrete (cast-in-situ)	In 1999, very good working conditions compared to the ordinary Portland cement concrete road
Underground and trench structures			
Drainage collector No. 5 (33km)	1966, Odessa, Ukraine	Alkali-carbonate activated BFS concrete (w/b 0.37)	40 concrete pipes. After 34 years, good conditions and appearance, no visual corrosion. Compressive strength 62 MPa (design strength 40 MPa)

Silage trenches	1982, Orlyanka, Vasilyevka region, Ukraine	Alkali-carbonate activated BFS concrete panels (2 x 3 x 0.2m precast, steam cured panels)	Access roads, bottom and fences of the silage trenches built with concrete panels. Fermentation of silage can corrode concrete, however, after 18 years, no indication of deterioration
Railway sleepers			
Railway sleepers	1988, Tchudovo Railway station, Russia	Pre-stressed reinforced alkali silicate activated BFS concrete sleepers	After 12 years, good working conditions. Strength 82 MPa (design strength 45 MPa) and carbonation < 1 mm/year

In addition, alkali-activated blast furnace slag-based cements and concretes were studied also for different applications in the construction field [392]:

- Autoclaved aerated concrete: produced in 1978 at Constructions Plan in Berezovo, Russia, it was made of 65% NaOH and 25% KOH as activators and several types of slags.
- Refractory concrete: Between 1981 and 1983 refractory properties of alkali-activated slag cements and kaolin fibres were studied in the Academy of Science of Ukraine, Kiev. This concrete was made of 3% blast furnace slag, 10% ground serpentinite rock, 50% kaolin fibres and 10% sodium metasilicate solution. This material had nine months service life compared to high-alumina cement with kaolin fibres, which have only one-month service life when they are used as refractory materials.
- Oil-well cement: Oil wells casing strings and columns (245 m height) in the Soviet Union Republics (Kirgizia and Tajikistan) were grouted with alkali-activated slag cements as oil-well cements. These materials were used at a depth of 3505 – 2052 m, temperature of 50 – 80° C and pressure of 28 – 61.5 MPa.

A recent relevant work for alkali-activated slag cement concretes was made in China. In November 2013 the construction started of the CRICS (Chongqing Research Institute of Construction Science) office building, in the Yuzhong District, Chongqing, the first structural application of site-cast alkali-activated slag concrete in China [393]. 550 m<sup>3</sup> of AAM concrete was used to build the main structural frame of the three floors building. The construction started on December 2014 and ended two months later, in February 2015. As an on-site cast, construction procedures are not different between AAM and PC concrete, but attention was given to quality control of raw materials, construction procedure and assessment; in addition, this work demonstrated that this kind of material can be used in low-temperature weather conditions, as the temperature during construction was sometimes below 5° C [393].

### 9.2.2 Adoption of alkali-activated fly ash concretes

Simultaneously with the construction of the first residential building in Ukraine, in 1960s Brandštetr first started the research on alkali-activated materials for construction at Brno University of Technology, Czech Republic [394]. During the years, different geopolymer concrete prototypes were studied, but only in 2002, a cement-free geopolymer concrete based on fly ash was prepared and called POPbeton®, with a compressive strength of up to 60 MPa and salts and high temperatures resistant [394]. Since 2008 alkali-activated materials has been studied and tested for a possible use in the construction field, like for example Geopol®, an inorganic sand binder used in the production of molds and cores for ferrous and non-ferrous metals casting [394].

In 2013, in California (USA), a precast alkali-activated class F fly ash concrete house was built [395]. Geopolymer cement is particularly suitable for precast concrete panels for its rapid strength

development and its requirement of heat to gain it, heat which is used also to accelerate curing in precast Portland cement concrete [395].

### 9.2.3 Wider adoption of alkali-activated concretes

#### 9.2.3.1 Australia

In the last decades, further studies and research allowed the development of new technologies based on alkali-activated materials and the realisation of several construction works, especially in Australia. In 2006, Zeobond Pty Ltd developed E-Crete™ (www.zeobond.com), a new cement binder consisting of fly ash and slag, which can be used in pre-mixed applications, such as footpaths, driveways, or slabs. This new construction technology was adopted in different projects (Table 9-3) in Melbourne, Australia, between 2009 and 2012 [390]. The diffusion of this material and its large-scale application around Australia was possible thanks to Zeobond, which built understanding and comfort with the use of this new cement binder technology and to VicRoads, the state roads authority in Victoria (Australia), which included E-Crete in their 2010 design specification (Section 703) as equivalent to PC for non-structural applications.

*Table 9-3 Zeobond E-Crete applications in Australia between 2009 and 2012*

Project	Year and place	Material	Additional information/Actual conditions
Salmon St bridge	2009, Port Melbourne, Australia	E-Crete (Pre-cast footpath panel segments)	55 MPa
Swan St bridge	2009, Richmond, Australia	E-Crete (Bridge retaining walls)	40 MPa
Brady St, Port Melbourne	2010, Melbourne, Australia	E-Crete (Footpaths)	25 MPa
Thomastown recreation and aquatic centre	2010, Melbourne, Australia	E-Crete (Footpaths and driveways)	25 MPa
Melton Library	2012, Melbourne, Australia	E-Crete (Pre-cast panels, decorative paving and in-situ works)	25/32/40 MPa

In the same period, another Australian factory, Wagners, developed and commercialised EFC (Earth Friendly Concrete), a new class of concrete obtained from the chemical activation of fly ash and ground granulated blast slag (www.wagner.com.au). This material was used for the construction of all heavy-duty pavements in the aircraft turning areas of the Brisbane West Wellcamp Airport in Brisbane, Australia (2014). The use of approximately 40.000 m<sup>3</sup> of Geopolymer concrete made it the largest application of this type of concrete in the world [396]. The material used should comply with the requirements, such as 4.8 MPa average flexural strength at 28 days and 450 micro-strain maximum drying shrinkage at 28 days (as per Australian Standards). EFC was used for its high strength, low shrinkage and good workability [394].

A new type of alkaline anti-evaporation spray was developed to reduce the evaporation rate and maintain the alkalinity of the fresh concrete surface [396].

In the same years, the company Wagners supplied the concrete for other construction projects in Australia (Table 9-4), using this Geopolymer concrete as an alternative to traditional concrete [397].

Table 9-4 Wagners EFC applications in Australia

Project	Year and place	Material	Additional information/Actual conditions
Weighbridge at Port of Brisbane	2010, Port of Brisbane, Australia	(EFC)	Pavement slab for a weighbridge. 32 MPa Geopolymer concrete
Private residence	Toowoomba, Australia	Wagner Geopolymer (EFC) pre-cast panels	Pre-cast panels (6 m x 2.4 m) for a retaining wall for a private residence. Design strength 40 MPa
Murrarie Plant site bridge	2009, Brisbane, Australia	Prefabricated Geopolymer concrete (EFC)	Precast bridge decks
GCI Building, University of Queensland	2013, Queensland, Australia	(EFC)	33 pre-cast floor beam-slab elements. Grade 40 concrete

### 9.2.3.2 United States of America

Also in the USA, the cement company CeraTech developed a new fly ash based hydraulic binder (FAHB), which is composed of 90 to 95% fly ash and 5 to 10% activators [398]. This new binder is used to produce Green Concrete (eGC), which does not need high temperature curing conditions (it can be air cured at 10° to 45°C) or high caustic activators and shows equal or better plastic and mechanical properties if compared to PC concrete [398]. FAHB is consisting of two powders, class C fly ash (82.16%) and class F fly ash (13.83%), and solid part of two non-caustic activators (4.01%).

CeraTech produces three different types of cements, which are cost-competitive with Portland cement and suitable for different applications: ekkomaxx™ (fire, acid and sulphates high resistance standard cement), kemrock™ (for higher acid and sulphates resistance) and firerock™ (fire resistance > 500°C) [399]. These cements have been used in different applications, such as road pavements, building foundations and precast materials; United States Marines Corps used firerock™ for jet engine tests pits in North Carolina, due to its resistance to high temperatures and kemrock™ was used in Texas to replace concrete trenches for hot molten sulphur at Gulf Sulphur Services company. After several years, CeraTech concrete still shows no visible sign of degradation [399].

### 9.2.3.3 Europe

In Europe, ECOCEM (in France and in Ireland) or ORCEM (in the Netherlands) developed new GGBS-based binders: ECOCEM (GGBS) and ECO2CEM (GGBS). ECOCEM (GGBS) is a low-carbon hydraulic binder, which increases strength and durability if blended with ordinary Portland cement (the percentage of replacement depends on national standards, for France it is 30%). Several applications (www.ecocem.fr) of this material in construction are placed in France (la Marseillaise tower, Marseille, and the Media Library in Vitrolles) and in Ireland (Cork civic office, Cork and Aviva stadium, Dublin). ECO2CEM (GGBS) is a high-performance alternative and it is used in combination with traditional cement to obtain a concrete with better technical performances. In the Netherlands, a replacement of 80% is allowed by national standards. This material finds different application, especially in the Netherlands (www.ecocem.nl), as concrete pavements or structural building elements (for example Saxion University of Applied Science or Niverplast head office in Nijverdal). These developments are to be regarded as more eco-friendly Portland cements, of which several more technologies have become available, and not AAM binders. The latter, though originally emerging in Europe as discussed in the previous sections, was therefore not be wider adopted until more recently by the emphasis of projects such as URBCON and DuRSAAM. Nevertheless, the availability of quality GGBS (such as ECOCEM) has been demonstrated ideally suited for AAM

concrete. AAM concrete is commercially available in Europe by a growing number of companies (such as for example Sqape in The Netherlands and Earth Friendly Concrete in Germany and the UK).

#### 9.2.3.4 Japan and Asia

In Japan, eco-cement and eco-concrete were developed as an eco-friendly material, in order not only to reduce GHG emissions but also to reuse industry waste as alternative fuel and raw material. This resulted for example in ‘Eco-cement’, that is a new type of Portland cement with refined municipal waste incinerator ash as up to 50% cement replacement. Although incinerator ash generally contains a high concentration of chlorides and toxic substance such as dioxins and heavy metals, the manufacturing process of eco-cement removes chloride ions and heavy metals by volatilisation [400]. Eco-cement chemical and physical properties are like PC, and it is standardized for ready-mix cement and pre-cast concrete applications [400]. In addition, Eco-cement is certified as eco-friendly material and related concrete products as “Eco-friendly Goods”, to encourage a preferential use of these materials [400]. This type of eco-cement is to be regarded as an eco-friendlier Portland cement, and as such not an AAM binder.

It is however noted that vast volumes of slags and ashes are available in Asia, facilitating the growing interest in AAM concrete also in that region. For example, a first structural application of AAM concrete in China has been reported to be dated in 2017.

### 9.3 URBCON demonstrator 1: pedestrian bridge in Rotterdam

#### 9.3.1 Renewal of pedestrian bridge using URBCON concrete

The city of Rotterdam lies within the industrial and metropolitan heart of the Netherlands. In total over 650.000 people call it their home. Rotterdam has one of the largest publicly owned Engineering departments in the Netherlands with over 500 employees specialising in all aspects of civil engineering. Together with the departments of Asset Management & City Development the Engineering department works to develop and maintain the city’s infrastructures as well as the public space.

The pilot project for URBCON in Rotterdam comprised the renewal of a pedestrian bridge. The old wooden bridge had reached the end of its technical lifespan and was to be replaced with a functionally equal bridge in concrete. Wood is not used as it decays quickly in the Dutch climate. The bridge consists of three spans and totals a length of 23,3m and a width of 3,4m (Figure 9-1). Of this bridge the three main spans haven been constructed with AAM concrete.

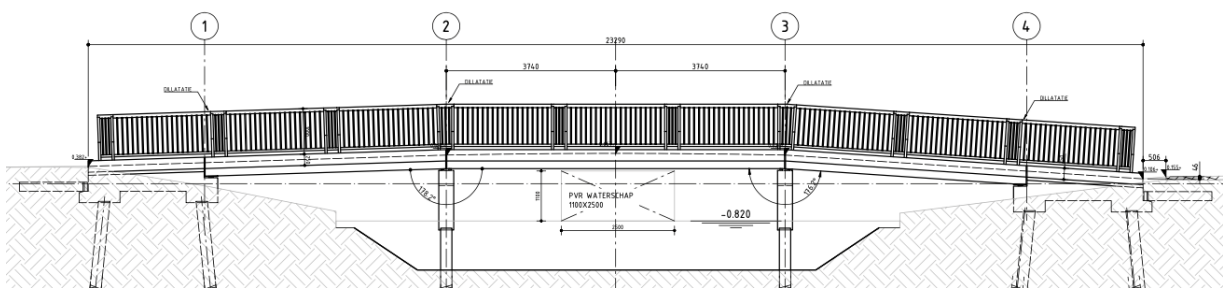

Figure 9-1 Overview pilot bridge at Rotterdam

#### 9.3.2 Tender and support team

Rotterdam was the lead partner in this pilot and was supported by the Delft University of Technology (TU Delft), Ghent University (UGent) and FDN Engineering. TU Delft provided the mixture design and

subsequent validation by tests of the mix design. UGent provided expertise on structural behaviour of the concrete and the verification of the structural concrete elements, based on the mix design. Rotterdam used the test and validation results in the implementation of the technical design of the bridge and its subsequent procurement. FDN advised a design and implementation aspects.

The tendering procedure followed is discussed in [Section 8.3.3](#).

### 9.3.3 Mixture

The inclusion of the clients' needs is an important scale level that has been included in the URBCON project. The realisation of a concrete bridge would normally fit standard procedures. In this case, Rotterdam, as client, prescribed the basic performance parameters for the concrete, based on known terms from Eurocode 2 (EN 1992). It turned out that the basic performance parameters could be described as 'equivalent to': strength class C45/55, exposure classes XD3/XF4 and consistence class S4. Rotterdam was able to formulate this based on a regular preliminary design of the bridge structure, assuming conformity to Eurocode 2. As a result, to the client, these performance parameters are now basic assumptions and should therefore be guaranteed in the project.

The scientists developed two distinct AAM concrete mixes, based on the multi-scale research (paste, mortar, concrete). During the process the client was requested to express their preference for an expected successful preliminary concrete mix design. Both mixtures rely on alkali activators and ground granulated blast furnace slag and absence of Portland cement. Mix URBCON1 uses only primary aggregates, while the other (Mix URBCON2) replaces 50% of the primary aggregates with secondary raw aggregates. The mixture with the secondary aggregates has been chosen for the pilot. Rotterdam's aim within URBCON was to gain as much as possible on circularity and on technology innovation. Especially the goal on circularity coexists with sustainability goals as the city of Rotterdam has high circularity ambitions for the near future. Therefore, any developed technology should contribute to these ambitions. Furthermore, the world outside URBCON is already experimenting fast and wide with AAM or geopolymer concretes. To contribute to the ever-expanding use of AAM concrete URBCON needed to be at the forefront of technology.

Both mixtures score well on environmental impact when compared with regular concrete (Table 9-5), expressed as global warming potential (GWP), as well as associated environmental cost indicator (MKI according to Dutch procedures). Only one mixture also encompasses a higher degree of circularity (with 50% recycled aggregates). Interestingly, the mixture with higher circularity also has a slightly more negative impact on the environment. It must be noted that LCA calculations on the environmental impact do not automatically take the benefits of circularity into account. To take into account circularity performance added parameters are necessary. A higher amount of secondary raw aggregates also has a drawback on the properties and the client deals with the trade off in this decision. The drawbacks on properties consist of material porosity, high creep, and frost-thaw issues. These issues have been mitigated with practical design choices for the bridge (see subsection below on the technical design, [Section 9.3.6](#)).

*Table 9-5 LCA of Rotterdam pilot mixtures versus standard mixtures in the Dutch concrete industry (as per research NIBE-institute)*

	URBCON	URBCON	RMX reference	Precast reference
MKI/ ECI [euro]	€ 17.62	€ 17.82	€ 23.94	€ 29.96
GWP [kg CO <sub>2</sub> eq ]	144.76 kg	145.81 kg	279.86 kg	386.53 kg



Concerning sustainability, the Dutch government is by law required to reduce CO<sub>2</sub>-emissions. In this respect, reference can be made to the case law on the ‘Urgenda’ lawsuit. Considering this legal requirement, the two mixtures have been analyzed to determine the MKI (environmental cost indicator, ECI) value and GPW value. This analysis has been carried out by the Dutch institute NIBE. Results are shown in Table 9-5. The abbreviation MKI stands for ‘Milieu Kosten Indicator’. It is a system to quantify the environmental damage of any activity or product causes, also known as eco-costs. This MKI-value considers a wide variety of environmental effects, not only CO<sub>2</sub>-emissions for example. Besides the MKI-value the specific amount of GWP is stated. Please note that the baseline material taken as reference is a CEM III/B concrete, based on GGBFS as normally used in The Netherlands.

### 9.3.4 Test protocol

The scientists at TU Delft developed the new concrete and performed a wide range of tests that show the properties. This has been done in accordance with a test protocol that has been set up between Rotterdam, TU Delft and UGent. The scientists thus proved that the basic performance parameters are obeyed. All participants contributed to this plan and results were discussed. The test protocol is listed in (Table 9-6):

*Table 9-6 Test protocol in the framework of the Rotterdam pilot*

No.	Test	#	Codes	Remarks
Design tests / 28 days				
1	Compressive strength	3	NEN-EN-196-1	1,7,28,56,128 days
2	Tensile Strength (splitting test) and / or flexural tensile strength	3	NEN-EN-12390-6, Splitting strength of cylinders.	-
3	Density	2	Test according to own method of lab or Rilem, cubes can be used for testing.	
4	Porosity (absorption test)	2	Test according to code: Rilem CPC 11.3	Method: Hardened concrete gas permeability test. The test consists in measuring the mass flow rate of gas in a steady state passing through a sample of hydraulic binder-based material subjected to a constant pressure gradient.
5	Thermal Expansion	3	-	Own method of lab
6	Shrinking	2	Rilem or ISO standard 1920-9	Autogenous & drying. Alternatively shrinking can also be measured on a test plate of a few meters' length for 30-60 days.
7	Creep	2	Rilem or ISO standard 1920-9	Basic creep and drying creep. Alternatively, creep can also be measured on a test plate of a few meters' length for 30-60 days.
8	Frost-Thaw resistance	4	CEN/TS-12390-9	-
9	Chloride penetration / rapid chloride test	3	ISESAM-own method of the testing lab	Determination of effective and apparent chloride ion coefficients in concrete by steady state and transient migration tests

10	Carbonation	2	NEN-EN-14630	An accelerated carbonation test (90 days is 100% moisture ambience) is required.
11	Reinforcement protection	2	-	The rate of corrosion and the polarisation resistance of steel reinforcement embedded in a matrix can be studied by the potential dynamic method.
12	Youngs Modulus E	2	NEN-EN-12390-13	-
13	Shear Modulus G	3	Acc. to proposal FDN	Specimens 100x100x500mm <sup>3</sup> – cantilevered over 100mm
14	Poisson's ratio	2	-	-
15	Flow test / setting time	1	NEN-EN 206-1	-
15a	pull out test with rebar	3	NEN-EN 10080	After 28 days curing
Suitability tests				
16	Compressive strength tests: at least 2 tests per mix	2/mi x	-	-
17	Bending or direct tensile tests, verification of elastic limit: at least 6 unnotched specimens per mix	6/mi x	-	-
18	Consistency tests and workability retention time: 1 test minimum according to placement process requirements	1	-	-
18a	burning concrete test To know w/c w/binder ratio	1	-	-
19	Proof Load test at PREFAB HALL / University or contractor (5 + 20%) kN/m <sup>2</sup>	1		For building committee. Connection railings must be covered to
Control tests				
20	Consistency	6/ba tch		
21	Compressive test	6/ba tch		
22	Bending test	6/ba tch		
Fundamental element tests				
23	shear strength on element level (p-u curve)	1		
24	4 pt bending test, crack width observations	1		
25	Also, with point load close to support	1		

The tests are needed to prove that (structural) verification rules from Eurocode 2 (EN 1992) are applicable (design by testing). The new AAM concrete doesn't fall in the scope of the EN206 requirements, negating the application of EC2. The question is how to provide evidence that the

structure is structurally safe. The concept of ‘design by testing’ was used as stipulated in Eurocode 0 (EN 1990). Next to the initial research on pastes, mortars and (small) concrete specimens, the client (also in agreement with the permit departments) required fundamental element tests (i.e. large specimen 4 point bending and shear testing). From these tests it became clear that for this concrete mix design it is expected that EC2 basic rules, amongst other for ultimate limit state (ULS) could be applied. The bridge itself will be monitored for a long time, to provide information on long term behaviour and properties. Finally, the bridge has been full-scale tested up to and beyond design load. During this final test the bridge deck was loaded up to 120% design load. Extended cracking would be expected which is a drawback to durability. Therefore, one of the smaller side spans has been tested. These spans have the same reinforcement as the main span and would not exceed crack limits during testing due to inherent higher strength and the shorter span.

Please note that the test protocol focusses on traditionally concrete related properties of the material. Besides the building permit, a water permit is required in the Netherlands. The Netherlands has separate authorities for water management, called ‘waterschappen’. TU Delft, knowing the chemical composition of the material, foresaw no obstructions in obtaining the water permit. However, after getting into contact with the water authority the following issues emerged:

- Supports in the canal
- Potential leaching

Rules and guidelines may differ from one authority to the other. In this case the supports for the new bridges in the canals would have been banned. The idea is that supports serve to collect floating waste, potentially clogging the canal. One is prohibited from building supports unless necessary. The bridge has a total span of 23m. The mix design was originally designed having in mind a pedestrian bridge with a span of no more than 5m, for two smaller bridges in a different part of Rotterdam. However, due to Covid related delays the URBCON consortium could not meet time constraints for the replacement of these bridges. Thus, the bridges were exchanged for the bridge which was ultimately built. The much longer span of this bridge necessitated supports because of uncertainties of the long-term behaviour of the material. The water authority found it difficult to accept the supports because of the application of the AAM concrete. In the end architectural and aesthetical arguments persuaded the authority to allow for the supports

The second concern was leaching. A leaching test was demanded and performed. This was even though no AAM material would come into direct contact with ground or water. Additionally, the bridge decks would be sealed by a coating. No special leaching risks were identified in the test. The water permit was obtained.

To Rotterdam it became clear after the tests that additional attention should be given to describe matters in tendering documents and that the contractor should be supported to use the newly developed AAM concrete mix. Some anomalies became clear from the tests (in comparison with regular EC2 concrete). More sensitivity to creep and frost-thaw was found. Consequently, the bridge design has been adjusted (shape that compensates for creep deformation, sealing of the upper sides and increased concrete cover). These are further discussed in [Section 9.3.6](#).

### 9.3.5 Long term monitoring

The long-term behaviour of the AAM concrete used in the pilot is not fully known. Therefore, long term monitoring is required to assure safe functionality over the lifespan of the bridge. The city of Rotterdam Engineering Department invests in fibre optics for monitoring structural health. As this technique is available within the Rotterdam organisation it was a suitable option. Moreover, it is a cost-effective system. The sensors are cheap, and installation is relatively straightforward. Special hardware is required to read out the sensor data and Rotterdam has this hardware available.

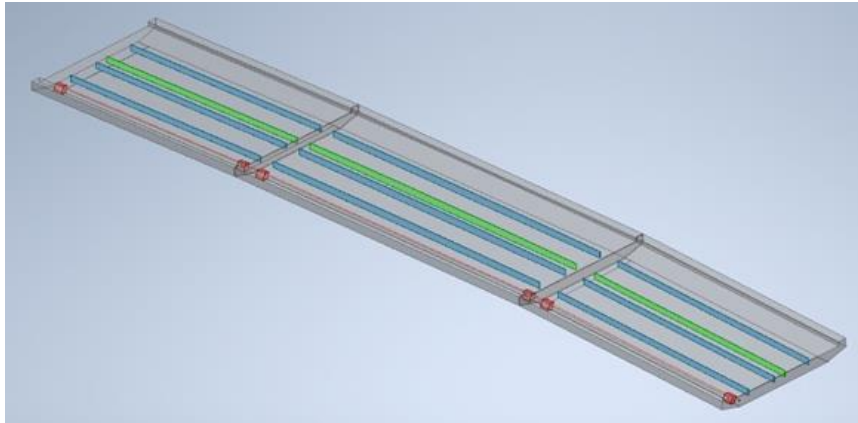

*Figure 9-2 Monitoring system used for the pedestrian bridge  
(in blue the strain measuring loops, in green the temperature loop)*

Each of the three decks is equipped with four glass fibre loops (Figure 9-2). These fibres, acting as strain and temperature sensors, are attached to the longitudinal reinforcement bars. They first run along the upper reinforcement and then loop back along the lower reinforcement. In this way the fibre measures compression of the deck as well as tension. One out of every four fibre loops does not measure strains, but temperature in the deck. This provides information to quantify the distortion of temperature on the bending strain measurements.

The fibre bundles are collected in distribution pipes and boxes from where the fibres are collected in a contact point which is placed next to the bridge. During the lifespan of the bridge proof loadings will be done using sandbags or water containers. The bridge's response will be measured using the fibres, thereby indicating the structural health of the bridge, when compared to predictions. In addition, the creep is measured periodically. During the first years of use the measurements are quite frequent. The frequency decays in later years. The measurement of creep behaviour is especially important. Knowledge on long term behaviour is most important to be able to scale up the size of the structures made with AAM concrete. Even more so for concretes with high levels of circular granulates such as used in this pilot.

In addition to the fibre optic system Rotterdam has good experiences with smart phone measurements. In previous innovation projects accelerometer results were found to be highly accurate in measuring vibrations. Several applications are available in or can be written for the mainstream app stores. Vibration measurement data is provided in .csv format, which can be analysed further processing software. This system is highly cost effective and readily available. It is used in concordance to the main measurement system.

### 9.3.6 Technical design

Calculations were done during the preliminary design phase under the assumption that the AAM concrete would have characteristics like concrete conform to EN 206, thus rendering EC2 applicable. After the selection of one of the two available mixtures, the design tests as shown in Table 9-6 would validate the characteristics. Some anomalies became clear from the tests. The AAM concrete turned out to be more sensitive to creep and have frost-thaw issues.

The fundamental element tests (see Table 9-6) were performed to confirm the assumption of the preliminary design. The interaction with steel reinforcement under bending and shear loading was tested. It was concluded that the bridge has sufficient structural safety according to the EC2 design rules. Still the design was slightly adjusted to compensate for the resulting design tests anomalies.

To summarize:

- Short spans ( $\leq 7\text{m}$ )
- Increased structural height (appr. 10%)
- Increased concrete cover (40mm)
- Coating of exposed concrete surfaces (epoxy)

In all other respects the bridge has been designed in accordance with Eurocode 2.

### 9.3.7 Construction phase

#### 9.3.7.1 Preparatory phase

As part of the tendering documents (Section 8.3.3) The contractor was given the opportunity to get to know the material and learn how to work with it. It was of paramount importance to make sure that the material characteristics found in laboratory circumstances would be met in the actual contractor stage. It would also allow for the team to fill in any information gaps left in the previous research phase.

As it turned out, some aspects of the workability needed further elaboration. For example, the workability class was set for S4 in accordance with EN 206. The mix was confirmed to satisfy S4 for 60 minutes. The distance between the concrete factory and the intended casting facility amounted to 45 minutes driving time, thereby not leaving sufficient time for casting. Furthermore, the effects of ambient temperatures were not fully known. The material had been developed at 20°C. This would not have been an issue as production of the bridge would have taken place around the summer period. Due to delays in procurement the production time was postponed to winter with ambient temperatures close to the freezing point. It was decided that during the first tests at scale of concrete cubes the topics of workability time and ambient temperatures would also be tackled.

When the recycled aggregates were delivered to the factory – as prescribed by the client – the aggregates were shown to be contaminated. The material originates from demolition of concrete structures. The contaminants included significant amounts of clay. In addition, pieces of plastic, steel wire, pieces of wood, ceramics, etc. were found. When asked the supplier indicated the contaminants might have come from the floor in the bunker where the material is stored. A second batch was delivered and found to have a similar amount of contamination as the first batch (Figure 9-3). The supplier stated that their product had already been treated with a washing procedure. It became apparent that the aggregates contamination quality would not improve. In smaller previous batches used at TU Delft the contamination did not appear to be so present in one instance and in another instance, it was hand washed (unbeknownst to the client up to that moment).



Figure 9-3 Recycled aggregates having some contamination

Washing the aggregates was not an option at the concrete factory as there was no equipment available on site for the necessary scale. Thus, washing was not considered a suitable option. As the project was still in the 'cube phase' at that point, it was decided to try and make the cubes and await the results. Concerns concentrated around the resulting strength and the workability. It was expected that the clay would degrade the workability. A total of 12 cubes were made. They were tested after 1, 7 and 28 days (Figure 9-4). 6 cubes were cured at 20 °C and the others at ambient temperatures in an open carport. After 28 days the compression strength had reached a minimum of 89% of the target value of 58MPa (lab conditions). This was sufficient as the requested target value by the client was 45MPa. This value was also used in the design calculations of the bridge.

The ambient temperature has a significant effect on the curing of the AAM concrete, especially in the first 7 days as shown by the differences between the orange and grey graphs as well as between the yellow and the dark blue graphs (Figure 9-4). The yellow and blue graphs come from the second phase. In this phase the test beams were made and again samples were taken to make cubes. At the time of the first trial ambient temperatures dropped to approximately +5°C at night, whereas during the second phase temperatures dropped to -2°C at night. This is clear in the early strength as depicted by the dark blue graph. In the end all cubes came within the before mention 89% strength or higher up to 96%. The final test cubes - from the deck batches - reached a measured strength of 60.5MPa (104%), see colours green and purple. Please note that in phase 3 the first test was done after two days instead of one day due to circumstances.

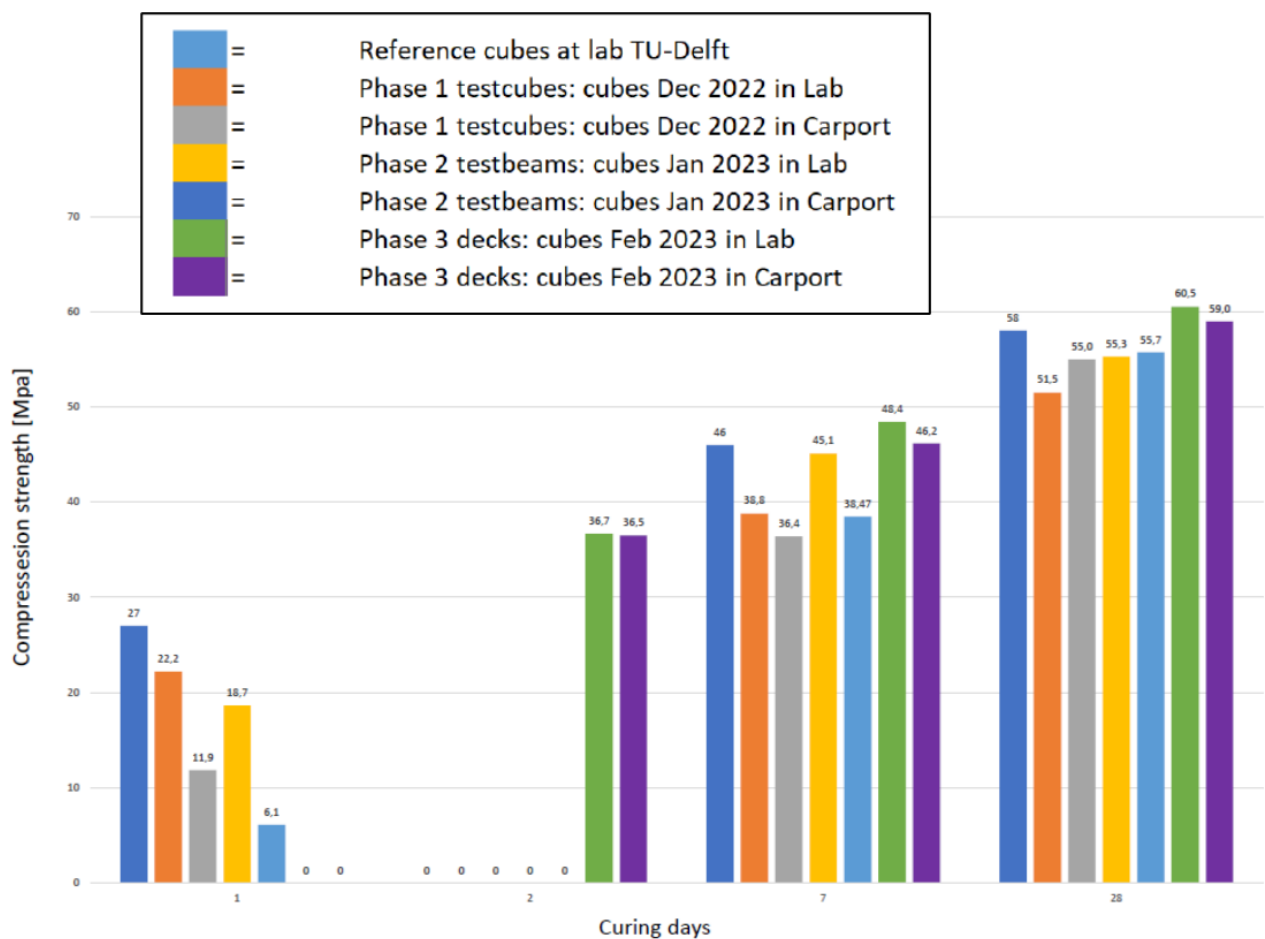

Figure 9-4 Strength development of test cubes



The low temperatures not only affected the curing of the cubes but also of the test slabs in reinforced concrete (RC). These RC test slabs have the following dimensions:  $L \times B \times H = 3200 \times 400 \times 150 \text{ mm}^3$ . They were to be tested after 7 days. Concerns rose whether the RC test slabs might have cured enough to have adequate testing. Environmental heating was applied to assist hardening successfully. When casting the RC test slabs there was some surplus of concrete so a 1x1m wide slab was cast as an extra test object. This slab was subjected to the same low temperatures as the beams prior to being heated. The slab was not heated as it was not part of the testing program. Given enough time it finally also showed good strength development, although no tests were performed on it. It appears that the cold environmental conditions induced a longer dormant period which could be overcome quickly by continued heating of the environment or by giving ample time to start the hardening process.

Concerning the workability, during the first phase two small retaining walls (about 1 m x 0,5 m x 1 m) were cast with a surplus of concrete from the cubes. No problems were found. The mixture proved to be workable for more than 90 minutes after production. Conventional tools could be used, such as vibrating needles, thus filling the mould completely.



*Figure 9-5 Retaining wall (left, wrapped in plastic) and surface cracks (right, unwrapped)*

Having two retaining walls also provided the opportunity to try with and without extra measures to cover the product and keep it moist during curing. TU Delft advised to cover the product with plastic film during curing to prevent evaporation of the alkali solution. The specimen without wrapping film showed small surface cracks. However, after a few days the cracks had closed again, revealing a level of self-healing for this material (Figure 9-5).

#### 9.3.7.2 Testing at reinforced concrete scale and proof load testing of bridge deck

The produced RC test slabs were tested at the UGent test facilities (Figure 5-6). This was done for practical reasons as UGent had done 4-point bending tests with RC slabs with similar dimensions for the URBCON pilot project in the City of Gent. Two separate RC test slabs were produced. One was designed to accommodate flexural failure. The other was designed to accommodate shear failure. A further discussion on this testing is provided in [Section 5.3.4](#).

The test results needed to show familiar failure modes (as for beams with EN 206 concrete) for both bending (Figure 9-6) and shear. Special attention was given to the ratio between load and deflection of the beams. Yielding of the reinforcement and subsequent cracking patterns were observed. Finally, the maximum load before failure was in line with the expected value based on the predicted Young's modulus as found per fundamental element tests.



*Figure 9-6 Crack pattern under bending load*

After these various tests at different scales up to RC slabs, still one test remained. It was the full-scale test of one of the actual bridge decks. This test was required by the local building authority and would serve as a final go- or no-go decision for the project execution. The URBCON team needed to explicitly demonstrate that the final product could carry the required load, including safety margins. During the full-scale load test the deck was similarly supported as in the final construction. The deck was loaded with water tanks that were filled up to a height of 0.6 m (Figure 9-7). A water column of 0.6 m represents a live load of  $6 \text{ kN/m}^2$  which is equal to 120% of the design load prescribed by Eurocode 1-2 loads of bridges. Thus, the test would not only show the capacity to carry the full load but would also show part of the structural reserve. The actual load was a little bit higher as the weight of de railings (absent during the test) was also simulated by the water.

The test load was reached in steps of 0.1 m. After each step measurements were taken before continuing. The deck was already equipped with the fully functional glass fibre monitoring system. Additionally, two conventional deformation sensors were used. The data of the glass fibre and the data of the conventional sensors were combined to verify the proper functioning of the glass fibre system.

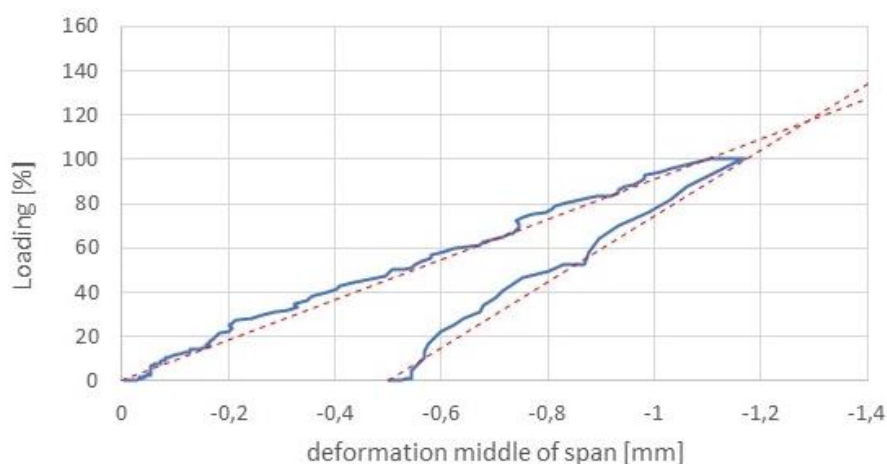

*Figure 9-7 Test-setup full scale load*

The chosen deck for the test was one of the shorter side spans. This was done to prevent excessive cracking during the test. As the maximal load exceeds the SLS load, cracks would be expected that could reduce the service life of the bridge. The deck has the same amount of reinforcement as the longer main span. Due to the shorter span the test load would not result in exceedance of the crack limit. Thus, keeping the tested deck in pristine order.

The following conclusions were drawn from the test: both the predicted deformations as well as the strains were confirmed with the measurements. The deck showed linear structural behaviour during

the proof load. As is clearly visible in Figure 9-8, the midspan deflection showed 0,5 mm residual deflection. This was attributed to the supports that showed hysteresis, which is a known aspect of neoprene bearings. The measured strain values appeared to be small in comparison with the resolution and accuracy of the fibre optic measurements. This is known from lab tests in the TU Delft, when concrete is in linear uncracked state. When strains increase (e.g. > 100 micro strain), results will be clearer. Finally, no cracks were observed in the measurement results, which corresponds with the visual inspection of the deck. Thus, the final building permit was granted and the bridge could be opened to the public.



*Figure 9-8 Measured deformation at the middle of the span*

### 9.3.7.3 Production and installation of the bridge deck elements

A few remarks should be made about the handling of the material. The contractor was made aware via the tender documents that some of the raw materials, the chemicals that contain the necessary alkali solutions have a very high pH-value and should be considered aggressive when in contact with the human body. Personal protection would be required. The following is based in feedback received from the contractor and describes the day the decks were cast.

The concrete mix was produced early in the morning (06:00) with an ambient temperature of 10°C. The sand and gravel were weighed and put in the mixer. Mixing took 60 seconds. After that the precursor was weighed and added, followed by another 60 seconds of mixing. Finally, the water and the activator were dosed and added together after which the complete mix was mixed for another 60 seconds. After this step the mixture was transferred to the concrete truck. Only 2m<sup>3</sup> at a time was mixed, so preparing the first 6m<sup>3</sup> took 3 steps. Samples for test cubes were taken from each load of concrete. The temperature of the ready mix was 22°C. Transport to the prefabrication site took 45 minutes, no difficulties were reported. After the final casting had been completed, two hours later the remainder of the concrete was poured out of the mixer without problems. It turned out it is necessary to clean the equipment immediately after mixing, delay makes it difficult to clean. The truck was rinsed out on site and was easily cleaned back at base.

During casting the ambient temperature was 12-15°C. A tub was used. The concrete consistency when it arrived on site 1 hour after start mixing (07:00) was equal to consistency class S3 (acc. EN 206) approximately. The material behaved very sticky and doughy like. Seeing the state of the material and because the material seemed to stiffen up even further it was decided to add water. The first deck was completely cast at 08:00. The fishing off the deck and planishing of the deck was difficult and heavy work due to the consistency which was still too low. On top of that the material still stiffened up quickly. Note that the desired consistency class was set to S4, so this requirement

was not met. This could be due to practical subtle mix design changes that occurred in the transfer from laboratory circumstances to real life factory circumstances. It could also be a consequence of the before mentioned contaminants in the recycled aggregates. The exact cause is not known. A special team was formed to keep working on the deck and get the surfaces and edges as smooth as possible. At around 11:15 the concrete was found to be set and a blue colouring had started to set in. The workable timeframe had practically ended. The deck was ready at 14:30 in the afternoon and was covered with plastic sheets. One hour later (15:30) the colour had turned nearly black, and it felt warm to the touch (Figure 9-9). A thermometer on the surface of the deck indicated a temperature of 28°C.



*Figure 9-9 Side span after demoulding still showing dark green-blue colour*

The second deck was cast using the slide attached to the back of the concrete truck. This batch arrived on site at 10:00. The consistency of this batch was found to differ from the first batch and roughly be a low F4 class. Thus, the concrete was far more workable, but still doughy like. Casting was completed after 45 minutes (10:45). Thanks to the higher consistency no rush was required to finish the deck. Nevertheless, final profiling was done immediately. Planishing was done from about 12:00 and took considerably less effort. It was finished at 14:30 after which the deck was covered in foil as well. This whole process was finished at 15:00. Having seen the heat development of the first deck this deck was put under a double isolation blanket instead of using heaters. Two days later the temperature on the surface of the deck was checked and measured at 25°C in an ambient temperature of 10°C.

The third deck was cast like the second deck. The concrete batch (6.5m<sup>3</sup> arrived on site at 10:40 with a consistency class of a regular F4. This meant the batch was even more workable than the second batch. Casting went even faster, finishing at 11:00. In this case finishing and profiling the deck had to wait for the concrete to set slightly. Profiling was done at 12:30, planishing at 13:30, last time profiling at 15:30, covered with foil at 19:00.

When the foils were removed, they were found to be highly greasy. This turned out to be raw material from the alkali solutions. Rinsing water was collected by the factory as it was brownish of colour. The factory was not sure if this water was clean enough to be drained into the canal. Samples were taken and the water was found to have a pH-value of 13 and be irritating to the skin. It also contained sediment of the precursor. All in all, this rinsing water needed to be disposed to a specialised facility. Though the final product does not release dangerous substances as was shown by the leaching tests, during the construction phase care should be taken. This means that casting on the building site is difficult and to be considered with care.

To summarize the experiences from the casting of the decks:

- The material seems to stiff up fast when delivered at a (too) low consistency class.
- Workable time at S3 class is approximately 4.5-5 hours.



- Workable time at F4 class is approximately 7-8 hours.
- The material develops a lot of heat.
- Strong colour changes were reported, from grey to blue to nearly black (but finally resulting in more usual grey concrete colour).
- As the fresh material can cause irritation extra care would have to be taken if a concrete pump is used as it splashes a lot.
- Rinsing water becomes polluted. Care should be taken to prevent that this - and other materials that come of the concrete during curing - enter the environment.

The relatively high temperature development was not expected based on preceding research and tests. At low ambient temperatures the curing process nearly even came to a halt in previous test trials. Apparently, this is an effect that comes into play when scaling up in size. Large temperature spikes and subsequent dry shrinkage was not foreseen and not considered in the technical design. Fortunately, shrinkage cracks were barely found on any of the tree decks.

The decks had all been fitted with lifting anchors. Installation, therefore, was straightforward as with any precast element in regular concrete (Figure 9-10).



*Figure 9-10 Lifting the decks in place*

All things considered, the contractors are very pleased with the project and the result (Figure 9-11 and Figure 9-12). One of the goals of the project was to provide SME businesses with a change to gain experience in the hopes to further stimulate the adaptation of AAM for structural purposes. This goal has also been reached as the concrete factory obtained permission from its shareholders to put in effort to further develop AAM mixtures.



*Figure 9-11 Final decks, awaiting gravel layer and railings*

### 9.3.8 Knowledge gain for Rotterdam

Rotterdam considers its participation in the URBCON project very worthwhile. Even more since the pilot has been successful. The URBCON project is about gaining knowledge and the development of alkali-activated concretes all the while negating barriers for the implementation in the construction industry. The URBCON project covers a great variety of potential alternative concrete mixtures which have not all been considered within the constraints of the pilot project. None of the proposed mixtures solely fulfills the present or future need of the concrete industry as a single solution, due to the lack of the specific required raw (secondary) materials. There is simply too much concrete being used in our society, versus availability of by-products. The application of alkali-activated concretes provides an important, yet partial solution in the wider framework of more eco-friendly concrete solutions. Most valuable to Rotterdam is the knowledge on how to approach and implement alkali-activated concretes for actual structural projects. However, Rotterdam as a governmental organization will not actively pursue for the creation of new types of mixtures, Rotterdam in its role as client will increasingly tender for solutions with more strict environmental footprints. The URBCON projects has provided insight and provided verification methods in key issues and parameters that play an important role in (structural) quality and performance of alkali-activated concretes. The Rotterdam pilot project shows the contours of the future tendering and verification process of structural projects with alkali-activated concretes.

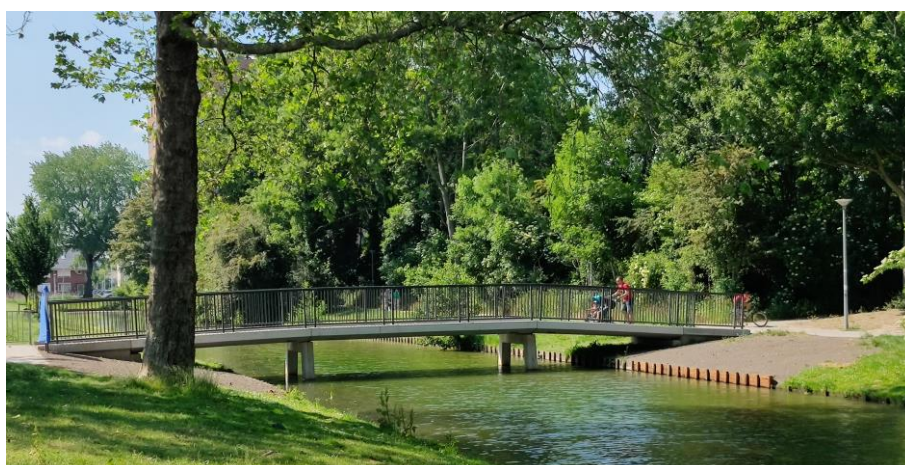

*Figure 9-12 Final bridge*

## 9.4 URBCON demonstrator 2: fire escape staircase in Gent

The Zonnepoort school is one of the various schools in the City of Ghent, Belgium. An additional outdoor fire escape staircase was required next to one of the school buildings, and this was selected as demonstrator to be executed making use of an architectural URBCON concrete.

### 9.4.1 Addition of fire escape staircase using URBCON concrete

The City of Ghent lies in Flanders, the northern part of Belgium. The city of Ghent consists of 14 boroughs and has over 260.000 inhabitants. Ghent harbours the Ghent University and several colleges, attributing more than 81.000 students to this vibrant city. Ghent has an economic spearhead policy focussing on four economic domains: cleantech, bio-based economy, health-tech, and digital tech. These four domains ensure the development of future-proof economic progress. The participation in this URBCON project aligns with the goal to make Ghent a hotspot for cleantech



actors and build a valuable ecosystem connecting industry, academia, policy, and citizens. Ghent wants to be an urban testing bed for developing sustainable technology.

During the URBCON project several city services worked together, making sure all the phases of the project were successfully executed. The department of economics oversaw the management, communications, and financial aspects of the project in close collaboration with the department of strategic subsidies. The day to day and building of the pilot was monitored by the department of facility management.

The Ghent pilot comprised the addition of a fire escape at the primary school 'De Zonnepoort'. This is a municipal primary school of the city of Ghent. The school provides a qualitative education tailored to the needs of the pupils. After the renovation of the school, a safe and functional fire escape needed to be added to be compliant. Hence it being an emergency staircase, it should only be used during an evacuation. For an appealing integration of the fire escape staircase in the school environment, and minimizing the disruption of the school activities, this demonstrator targeted a precast structure in architectural concrete (visible concrete). A schematic of the design, shown from different angles, is given in Figure 9-13.

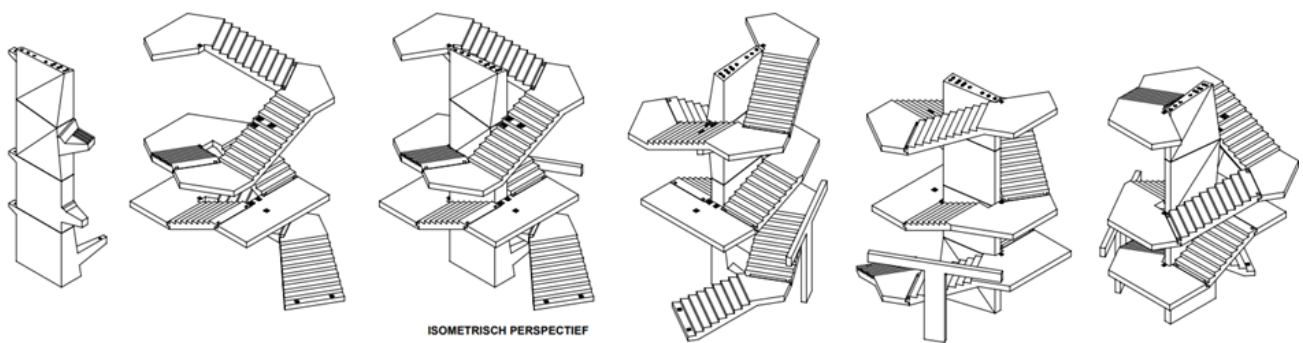

*Figure 9-13 Precast outdoor staircase 'De Zonnepoort' (schematics and sale model)*

Additional to the fire staircase, a concrete bench was developed in front of the school (see [Section 9.6.2](#)). These benches provide a pleasant play stimulus to the children or a resting place for passers-by.

For the construction, Furnibo as general contractor put together a construction team, involving Back Architects, engineering office Mouton and concrete manufacturer Enjoy Concrete. The building team worked in consultation with the Belgian URBCON project partners Ghent University, City of Ghent and ResourceFull. Landlord of the project was the facility management department of the city.

Manufacturing company Enjoy Concrete shared their expertise for the creation of the staircase in the factory. Afterwards, the precast members were transferred to the elementary school where they were assembled by the contractor. The staircase is 9.45 m and consist of 12 individual components and one T-frame.

An artist impression of the school with the staircase as has been realized and with the proposed renovated covered and outdoor playing area, is given in Figure 9-14.

An image of the finalized staircase is given in Figure 9-15. The mixes applied for the staircase focused on the alternative alkali-activated binder system and used 100% natural aggregates. This has been chosen to make the mixture not too 'exotic' and make sure it will pass all quality tests. Alternatively, recycled aggregates were used for the street furniture in front of the school.



*Figure 9-14 Ghent pilot artist impression of the staircase and intended new playing area (courtesy Back architects)*



*Figure 9-15 Ghent staircase as built*

#### 9.4.2 Information on the development of the binder and mix design

The architectural concrete staircase required the following concrete quality:

- Strength class C45/55
- Environmental class EE3
- Slump class S5 (>210 mm)
- Flow stability of 60 min

The binder was firstly developed by Ghent University and ResourceFull on paste and mortar level and tested in terms of workability, open time, shrinkage, and strength development.

The binder was based on a ternary blend of blast furnace steel slag, copper slag and stainless-steel slag in combination with alkaline activators. Best performing binders were upscaled to concrete level. The following material properties were measured and benchmarked to the commercial reference concrete mixtures, as given in Table 9-7.

Taken into account the LCA analysis, cost calculations and an extensive period of laboratory and pilot scale testing of Ghent University and ResourceFull in collaboration with manufacturing company Enjoy Concrete, two binder mixtures were finally selected for production (Table 9-8), a hybrid mix used for the stair case and a ternary blend mix used for a T-frame next to the stair case.

*Table 9-7 Test protocol in the framework of the Ghent pilot*

	<b>Test</b>	<b>Standard</b>
<b>Fresh properties</b>	Slump stability	EN 12350-2
	Fresh density	EN 12350-6
	Air content	EN 12350-7
<b>Mechanical properties</b>	Compressive strength	EN 12390-3
	Flexural strength	EN 12390-5
	Splitting tensile strength	EN 12390-6
	Elastic modulus	EN 12390-13
<b>Durability properties</b>	Chloride Migration	NT Build 492
	Carbonation	EN 12390-12
	Water absorption	
	Freeze and thaw - salt	EN 12390-9
	Reinforcement corrosion	
<b>Structural Properties</b>	Creep and shrinkage	EN 12390-17
	Pull out (steel rebars)	EN 10080
	Flexural strength - slab	Labo Magnel
	Shear capacity - slab	Labo Magnel

*Table 9-8 Selected mixes for the Ghent pilot*

<b>Material</b>	<b>Ghent pilot mix 1 (hybrid)</b>	<b>Ghent pilot mix 2 (ternary)</b>
GGBFS	37%	23%
Copper Slag		40%
Stainless Steel Slag	37%	11%
CEM I 52.5	24%	
NaOH		2%
Water glass		11%
RSF-ASF3-CC2	3%	

### 9.4.3 Production and installation of the precast elements at Zonnepoort

#### 9.4.3.1 Production of the precast elements

Enjoy Concrete operates in the field of high-quality architectural concrete, where strict requirements are applied for surface properties and dimensional tolerances. The moulds for this project were custom-made using high-grade concrete plywood. The geometry of the riser/tread is identical for all stairs (150/300 mm), allowing the same mould to be reused for all stair components. Execution drawings at a scale of 1/20 were prepared in advance for all elements. The joints and corners of the formwork were sealed using a proprietary method, achieving sharp corners with a minimal rounding radius (approximately 1 mm). Some impression of the production of the elements are given in Figure 9-16.



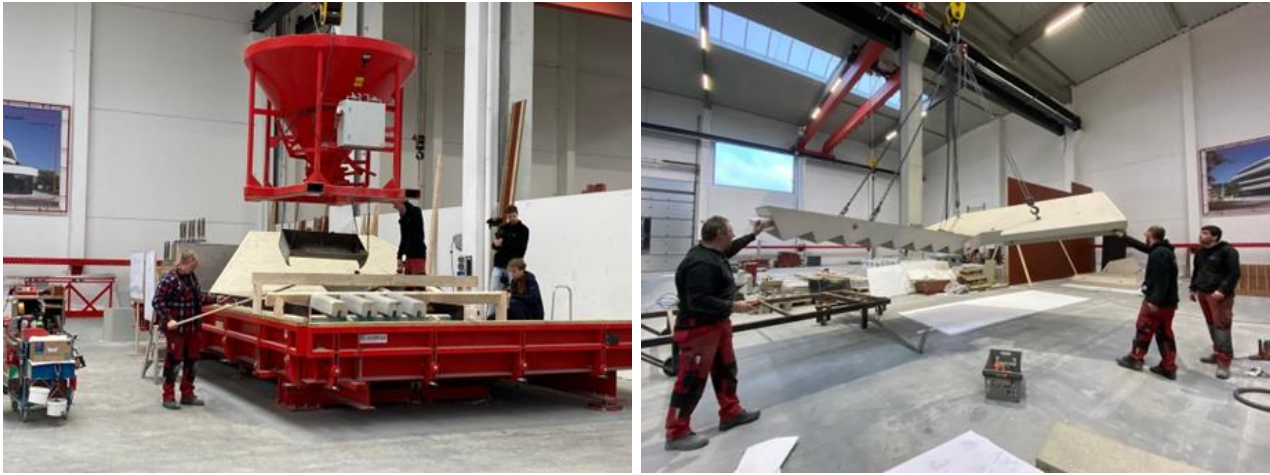

*Figure 9-16 Production of precast elements for the staircase*

The curing of the URBCON concrete need to be done with care (and with more care compared to PC concrete), otherwise a set of problems will pop-up such as leaching of the activators (efflorescence) and cracking due to drying. The influence of the curing conditions was also studied beforehand at the university laboratory (Figure 9-17), as well as during some casting trials in the factory. The elements were covered during the first night to allow the elements to cure in a more humid environment. An important aspect is that all elements were stored indoors, protected from rain, wind, and significant temperature fluctuations. This was maintained for a minimum of 5 days after pouring the concrete, at which point a transport strength of 30 N/mm<sup>2</sup> was achieved.

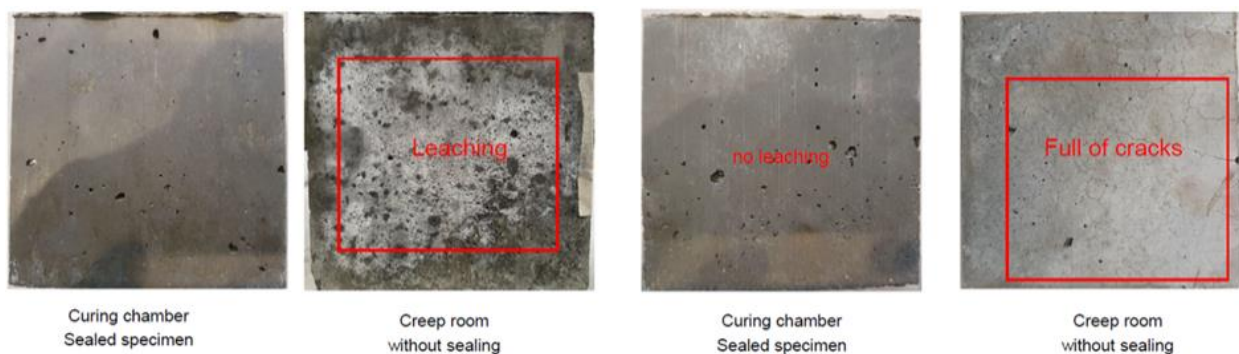

*Figure 9-17 Investigation into curing conditions*

#### 9.4.3.2 Installation of the precast elements

After the prefabricated elements were manufactured, they were carefully transported to the construction site and installed according to the design (Figure 9-18). The installation process involved the precise positioning and connection of the different elements to create a sturdy and stable stair construction. On average, only 1 to 2 elements were transported to the site per day. For the placement of the elements, a telescopic crane was used. From then on, the execution of the work proceeded like traditional construction projects. Of course, some specific considerations arose, primarily related to the school environment and design of the staircase rather than the type of concrete. Strict agreements were made with the contractor to address these concerns, and they were meticulously followed.



*Figure 9-18 Installation of the precast members at the school*

#### 9.4.3.3 Proof-load testing of the finished staircase

A load test was conducted on the stair tower. The setup was as follows: a maximum eccentric load was applied by placing the test load on only one side of the central support wall, specifically on the upper stair tread S7, along with the corresponding sections of the adjacent landings B6 and B7. This load was gradually increased to 120% of the intended design load.

The load test was performed using water tanks, and the vertical deformations were monitored. According to calculations, the maximum allowable deflection was 10 mm. During the test, a deflection of 7 mm was measured, which fell within the acceptable range.

#### 9.4.3.4 Information about the T-frame

The concrete T-frame serves as the termination point of the existing veranda roof. The load to be supported is limited to the self-weight of the concrete beam and a small triangular zone of the lightweight roof. This element is designed and detailed to closely align with their simple schematics: a single column clamped into the foundation, with a cantilever beam extending at both sides of the column. Due to the low load, the T-frame can be designed with a slim profile. The member is also simple and cost-effective to fabricate, making it feasible to produce in multiples if beneficial for research purposes. Thus, this T-frame not only holds architectural significance but also serves as an ideal test setup. Indeed, a more challenging mix design was used for this member, for which some shrinkage cracking appeared not to be fully prevented during the final production. Nevertheless, the T-frame was installed as a witness of the importance of controlling shrinkage cracking in these mix designs, as the safety of the T-frame was verified and proven by means of a proof-load test and as stainless-steel reinforcement was used in the T-frame to lower the risks of long term durability in reference to this highly experimental mix design. The surface of the T-frame was grid blasted as a finishing for the architectural concrete look. Figure 9-19 shows the installation of the T-frame.





*Figure 9-19 Installation of the T-frame at the school*

#### 9.4.4 Testing and long-term testing

As already mentioned with the pilot in Rotterdam, the long-term behaviour of AAM concrete is not fully known. Therefore, apart from the extensive accelerated durability testing and load bearing capacity testing performed on laboratory scale, further testing was executed as part of the construction of the staircase and in view of the monitoring of the concrete quality. The testing program associated to the staircase, beyond that of the initially conducted laboratory scale study and in due consideration of the upscaling of the laboratory mixes, comprised the following parts:

- (1) Factory upscaling and quality control testing, as mainly conducted by Enjoy Concrete. This comprised several trial castings and manufacturing of small to medium scale concrete members and associated testing of workability, compressive strength, influence of factory temperature on the casting, etc. The test result provided confidence on the quality of the upscaled AAM concrete, to use the large-scale concrete mixing infrastructure of Enjoy Concrete and to be able to produce visible concrete in a consistent way for the different precast parts of the staircase.
- (2) Proof load testing of the staircase and of the T-frame next to the staircase. Hereby, the as-built structure was loaded, and deflections were recorded. The observed load deflection behaviour during the proof load testing was evaluated by the engineering office and found compliant with the design assumptions. This allowed to open the staircase for its intended use. The measurements have been documented as benchmark in case the proof load testing would be repeated in the future, as part of the intended monitoring program.
- (3) A T-frame supporting a small roof next to the staircase was installed as part of the project. This roof was further utilized to store several specimens in view of monitoring the concrete as exposed to the same conditions as the staircase itself. This comprises cubes and prisms to verify concrete properties such as compressive and tensile strength, modulus of elasticity, water absorption, carbonation, .... These specimens are intended to monitor the concrete performance over time (by Ghent University in collaboration with the city of Ghent), tentatively scheduled for testing after 1, 5, 10 and 20 years. A set of specimens has been tested immediately after installation of the staircase as a means of reference. These initial tests proofed compliance of the concrete performance and future repetition of these tests, as a means of monitoring, will provide valuable data about the durability and performance of the applied AAM over the longer term.
- (4) In the framework of the monitoring described above, also a yearly visual inspection of the structure will be conducted by the city of Ghent facility management department. During

these inspections visible indications of ageing of the structure will be monitored. These visual inspections will focus on areas that are prone to exposure to rain and have a higher number of cracks (this includes the T-frame that demonstrated some shrinkage cracking). During these inspections, there will also be a reminder on the restricted use of road salts during winter, as freeze-thaw resistance in combination with de-icing salts was not considered in the initial developments of the concrete mix and its related exposure class.

#### **9.4.5 Knowledge gain for the city of Ghent**

For the city of Ghent the participation to the URBCON project was very insightful and successful. Ghent already had experience with low carbon concrete. An example was the 110 m<sup>2</sup> circular pavement added in the Leeuwstraat using low carbon pavers made by carbonating slags (slags from stainless steel production). The URBCON project adds to this existing knowledge and further challenges the city's processes of tendering, building and being a testing bed for new technologies.

Particularly for tendering procedures, the URBCON project provided insightful exchanges with the partners and other actors in and around Ghent. Building the Ghent pilot with this innovative alkali activated concrete of course provokes the question: "Why not always use low carbon building materials?". Here we face challenges of habit, certification and limited financial resources. Albeit these challenges, and give the positive experience with the Zonnepoort demonstrator, the city of Ghent will further work on this topic and strive to make meaningful changes in close collaboration with the partnerships solidified during the URBCON project.

### **9.5 URBCON demonstrator 3: foundation of circular office building in Westerlo**

#### **9.5.1 URBCON concrete as part of a new circular office building**

In the year 2019, Kamp C organized a circular tender as a preparation for the building of the first circular building in Belgium: 't Centrum. In this building as much as possible elements of circular building are being integrated. As part of the building process, the initiator Kamp C, together with lots of partners, has set up an interesting and innovative learning process, from which the whole sector could put some inspiration.

The precast foundation feet and beams of the building are made of URBCON concrete. These are being produced in standard sizes, whereby they are perfectly demountable and reusable in new projects. Also, the slab of the lift shaft is made with URBCON concrete, in this case by means of cast in-place AAM concrete.

The Kamp C demonstrator is as mentioned the implementation of URBCON concrete in the 100% circular office building on the site of Kamp C in Westerlo (BE). Further to the concrete associated to the foundations, also permeable paver blocks in AAM concrete have been applied later in the project around the office building.

Under the direction of ResourceFull and with the support of Ghent University, a test program was initiated for the development of a suitable concrete mixture for the foundations of 't Centrum with the least possible environmental impact. The research started with the development of sustainable binders based on industrial residues.

Traditional cement reacts with water, after which it hardens and develops strength. Water alone is not sufficient to initiate the reaction of these industrial residual flows used in URBCON concrete. To initiate the reaction mechanism, the addition of chemical activators is necessary. In the lab, therefore, we worked hard to find the right combination of raw materials and chemical activators. At mortar level, properties such as tensile and compressive strength, flow and shrinkage were examined. In the

concrete labs, the mixtures were scaled up based on the material and concrete properties of the intended application. The granular skeleton was optimised with an in-house developed gasket model using the available sands and aggregates from the producer.

Based on the tests on fresh concrete (flow, flow stability, curing time), on cured samples (compressive strength, shrinkage, density, E-modulus) and on durability (freeze-thaw, resistance against carbonation, chloride penetration), equivalence could be demonstrated of the developed AAM-concretes with two PC-concrete mixtures: (i) C20/25 EE2 S5 and (ii) C30/37 EE3 ZVB.

### 9.5.2 Production and installation of the foundation

The production of the foundation blocks (footings and beams, Figure 9-20) was carried out at Willy Naessens Construct in Oudenaarde. Since the raw materials were already available in the silo, the implementation of the developed eco-binders was limited to the digital adjustment of the mixing ratios and the manual dosing of the ResourceFull activators (15 - 40 kg/m<sup>3</sup>). The mixtures had a fluidity of 60 minutes, which is more than sufficient in a prefab production environment. After a final quality control, all foundation elements were approved and successfully installed by Beneens in Westerlo (Figure 9-21). Finally, 6 m<sup>3</sup> of fresh eco-concrete was delivered from the ready-mix concrete plant J. Janssens & Zonen in St.-Lenaarts. By using the URBCON concrete composition in these foundation blocks, 22,500 kg of secondary raw materials could be used and 13,000 kg less CO<sub>2</sub> was emitted compared to the use of traditional foundations.

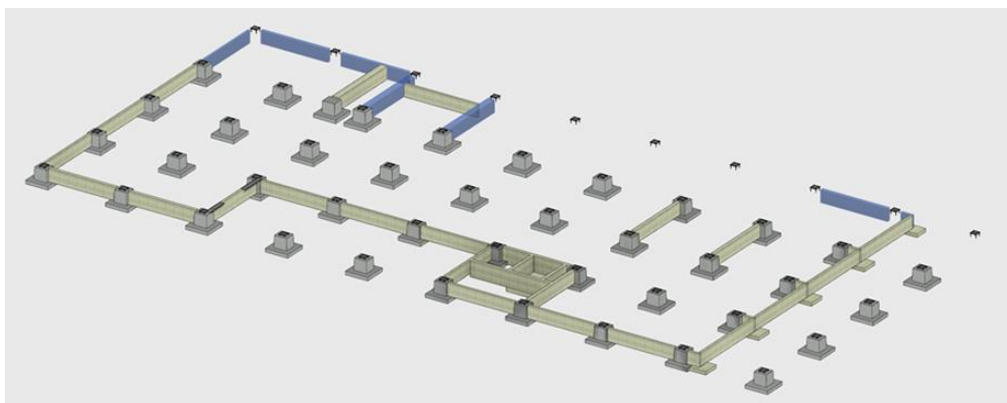

*Figure 9-20 Overview of the precast foundation elements in AAM concrete*



*Figure 9-21 Installation of precast foundation elements (picture back end shows existing building)*

With the showcase of 't Centrum, Kamp C hopes to gain interest from the building sector and hopes to show them that using eco-friendly concrete is possible and easy. In this way Kamp C would like to speed up the implementation of innovative concrete products.

The biggest differences in terms of cost compared to traditional concrete is that the concrete producer must spend extra time and effort, because it's new for him. Also, the percentage of material cost is different. But the indications are that working with URBCON is very cost efficient.

### 9.5.3 Information on the development of the binder and mix design

The concrete foundations required the following concrete quality:

- a strength class of C20/25
- environmental class EE2
- slump class S5 (>210mm)
- flow stability of 60 min

The binder was firstly developed on mortar level on samples of 40x40x160 mm<sup>3</sup> and tested in terms of workability, open time, shrinkage, and strength development (EN 196-1). The selected binder (Table 9-9) was based on GGBFS in combination with a blend of alkali salts (RSF ZeroCem BFS)

*Table 9-9 Binder design for the I3 foundations*

<b>I3 Foundation URBCON: ResourceFull ZeroCem Binder</b>	
GGBFS	91.7%
RSF – ZeroCem	8.3%
Binder	458 kg/m <sup>3</sup>
w/b	0.41

Once the suitable binder was selected, the developments on concrete level were performed on samples of 100x100x100, 150x150x150 and 500x200x100 mm<sup>3</sup>. The following material properties were measured and benchmarked to the commercial reference concrete mixture of the concrete producer:

- strength development at 1 ,2 ,7 ,28 90 days (EN 196-1)
- workability and flow (NBN EN 12350-2)
- shrinkage (NBN B 15-216)
- open time
- density
- freeze-thaw without de-icing salts CEN/TS 12390-9

By benchmarking these results with the reference concrete mixture, equal performance was demonstrated.

### 9.5.4 Information on the dimensioning of the components

For the Kamp C pilot, the most important aspect of the foundations was the circularity. The building teams chose a standard format so that the foundations are modular, demountable and can be re-used in the future (Table 9-10).

*Table 9-10 Dimensions of the plinths/beams*

	Length [mm]	Width [mm]	Height [mm]	Number [mm]
Beton_Prefab_140	735	140	760	1
Beton_Prefab_140	736	140	760	4
Beton_Prefab_140	4200	140	760	6
Beton_Prefab_140	4300	140	760	6
Beton_Prefab_140	4860	140	760	3
Beton_Prefab_140	5000	140	760	1
Beton_Prefab_140	5030	140	760	1
Beton_Prefab_200	2300	200	940	2
Beton_Prefab_200	4200	200	760	5
Beton_Prefab_200	4200	200	940	1
Beton_Prefab_200	4300	200	760	3
Beton_Prefab_200	5170	200	940	1
Beton_Prefab_400	4300	400	760	2
Beton_Prefab_400	4650	400	760	1

### 9.5.5 Information on the by-products used and their processing

By-products have been used both in terms of the binder and for secondary aggregates:

- Blast Furnace Slag from steel production (GGBFS)
- Secondary aggregates from Imerys

Foundation total: 23 tons of GGBFS

Since GGBFS is readily available on the market, it did not require further processing and was ready to use in the URBCON concrete mixture. The processing steps already applied to the GGBFS include water granulation (by the steel producer, here ArcelorMittal) and ground/milling (by the distributor, here Ecocem). The secondary aggregates from Imerys were provided already graded in different required fractions.

### 9.5.6 Information on conducted quality control testing

The concrete foundations required the following concrete quality:

- strength class of C20/25
  - Compressive strength was measured at 1, 2, 7 and 28d according to EN 196-1
  - 28d strength > 40MPa
- environmental class EE2
  - Although not necessary for the environmental class at hand, freeze-thaw measurement without de-icing salts according to CEN/TS 12390-9 was performed and showed normal degradation according to EE3 environmental class.
- slump class S5 (>210mm)
  - Slump measured according to NBN EN 12350-2
  - Slump t0=255mm
- flow stability of 60 min
  - Slump measured over time according to NBN EN 12350-2
  - Slump t60min = 230mm



During production the following quality control measures were taken. These tests were performed every two concrete pours.

- Cubes with side length 100 mm were taken and strength development was measured
  - Strength at 7d exceeded the threshold to declare as C20/25
- Water/binder factor was calculated by dry firing
  - This confirmed proper dosing

### 9.5.7 Knowledge gain for the partners involved in 't Centrum

The AAM foundation elements for the circular office building have been successfully produced and placed in full satisfaction of the 't Centrum design and build team, as well as the landlord Kamp C (Figure 9-22). Experiences have been that positive that it was decided to also apply this concrete technology for the concrete paver blocks around the building. As part of the mission of Kamp C – being a knowledge transfer centre on sustainability and innovation in the construction sector – and given the positive experience, URBCON concrete will remain to be showcased and stimulated for future projects. The involved companies in the precast foundation elements, in the ready-mix concrete for the foundation slab, as well as the paver block producer, all gave positive feedback and declared to be willing to use AAM concrete in future projects.



*Figure 9-22 Circular office building in use with AAM pavers and with AAM foundation elements (extra element put next to the building for show-casing purposes)*

## 9.6 Street furniture in URBCON concrete technology

### 9.6.1 Historical case: reinforced concrete cantilever bench in Rotterdam

#### 9.6.1.1 Background

The reinforced cantilever bench was designed and produced in TU Delft, and placed in Rotterdam area (GJ de Jonghweg) in 2017. An alkali-activated slag and fly ash concrete mixture was developed after optimization according to the requirements of the concrete for the bench. By using the alkali-



activated concrete as a main component, the CO<sub>2</sub> emission for the production was reduced while the performance of the cantilever bench was ensured.

#### 9.6.1.2 Structural design

The cantilever bench had a length of 3 meters and a height of 1.5 meters. The structural design was based on critical load combinations, including life load, snow load, self-weight/dead load and wind load. The load combinations were calculated according to Eurocode 1 EN 1991. Governing ultimate load state was determined, tilting moment equilibrium, structural torsion, reinforced concrete with pure bending and shear capacity of critical sections were calculated. Based on the calculations, structural design was completed.

#### 9.6.1.3 Development of alkali-activated concrete

For a successful production of the bench, the workability of the alkali-activated concrete should be sufficient for casting. The mechanical properties and long-term performance should meet the requirements based on structural design. Blast furnace slag and fly ash were used as precursors, sodium hydroxide and water glass were used as alkali-activators, quartz sand and natural gravels were used as aggregates, retarder was used to tailor the setting time of fresh concrete mixtures. The amount of the precursors was 400 kg/m<sup>3</sup> of concrete, the combination of sodium hydroxide and water glass, and the liquid-to-binder ration were varied to investigate their influences on workability, setting time, and mechanical properties (compressive strength, flexural strength, elastic modulus, and Poisson's ratio) of alkali-activated concrete. Curing regime (i.e., 1, 3, 7 and 28 days of moist curing) was studied to show its influence on drying shrinkage and drying shrinkage-induced cracking. Longer moist curing time was proven efficient in mitigating the drying-shrinkage-induced cracking.

#### 9.6.1.4 Production, curing and showcase

The mould with placed rebars of the cantilever bench (Figure 9-23) was prepared in the lab of TU Delft. Alkali-activated concrete was mixed and cast into the moulds, following by sealing of the mould with plastic films to prevent moisture loss. After a period of curing, the bench (Figure 9-24) was demolded and then transported to the site.

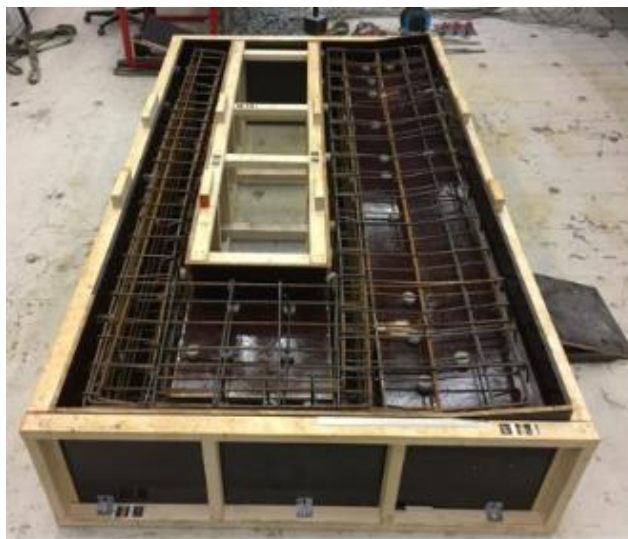

Figure 9-23 Mould and rebars for the bench [Z. Aldin, 2017, unpublished report]



*Figure 9-24 Cantilever bench on site [<https://sites.google.com/view/cmmb-tudelft/news>]*

### 9.6.2 Architectural concrete bench in Gent

Further to the URBCON demonstrator at the Zonnepoort school at Gent (Section 9.4), the street zone in front of the school was reorganized. This involved creating a small green zone with street furniture, whereby for the latter it was opted to produce a bench and tiles in AAM concrete, with exposed secondary aggregates as visual concrete. This second demonstrator in Ghent is the street furniture, placed on the redecorated square in front of the school. It contains 3 different designs, being a bench and some steppingstones (Figure 9-25). The concrete mix design was developed by ResourceFull and based on the same hybrid binder as the staircase but incorporates recycled aggregates from Imerys in the granular skeleton.



*Figure 9-25 Designed street furniture*

The use of recycled aggregates in the mixture required some extra attention, due to the increased water requirement and resulting effect on workability. However, by implementing the appropriate flow stabilizers, a concrete mixture with desirable workability and strength development was achieved. The self-compacting behaviour of the concrete mixture, combined with the early strength exceeding 15 MPa, resulted in an easy, safe, and efficient mixture to use by the industrial manufacturer. To highlight the presence of the recycled aggregates, the concrete pieces were polished, showcasing simultaneously that traditional surface finishing techniques can be applied to URBCON concrete (Figure 9-26).

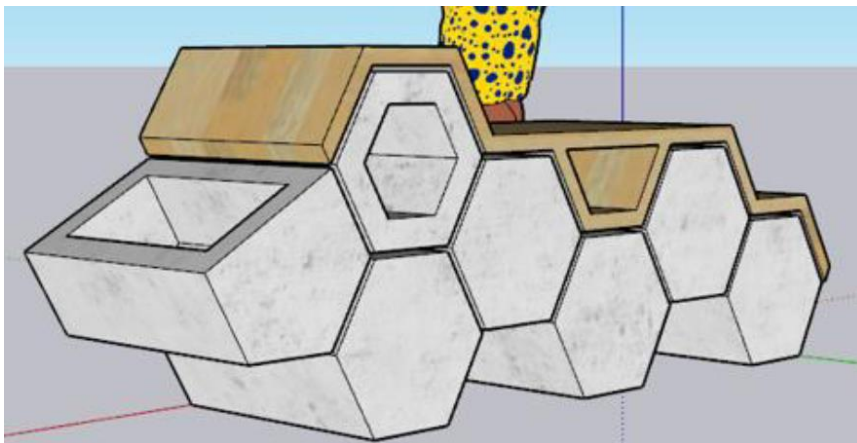

*Figure 9-26 As-built street furniture in front of Zonnepoort school*

### 9.6.3 URBCON concrete family showcase bench in Westerlo

To showcase URBCON concrete as a family of concrete recipes, a modular bench made of precast concrete elements has been produced. Each element of the bench involves another AAM mix formulation. This bench showcasing the URBCON concrete family concept is placed at Kamp C in Westerlo to highlight the technology to visitors. Hence, this bench represents a technology demo stand by the URBCON partnership.

An initial design sketch of the modular bench is given in Figure 9-27. The bench design exists of inter-connectable pieces, with a wooden seating on top. For the modular concrete elements use is made of different mix designs provided by the research partners (UGent, USheffield, TU Kaiserslautern, TU Delft, ResourceFull). As such, 5 hexagons have been made by ResourceFull, following the different mix specifications (Figure 9-28). Next the hexagons have been transported and assembled at Kamp C (Westerlo).



*Figure 9-27 Design sketch of modular bench for technology demonstration*

Given that the bench is in unreinforced concrete and basically not exposed to a harsh environment, also given the ambition to demonstrate different URBCON mixes representative for a multipurpose URBCON concrete family, no specific requirement was set forth. All mixes achieved proper workability and curing conditions to make the hexagon elements. Extra cubes were cast to observe the compressive strength obtained with these different mixes, as reported in Figure 9-29.





Figure 9-28 Hexagons made of different URBCON concrete types for a modular bench (note the darker colour of demoulded specimens, that disappears after a few days)

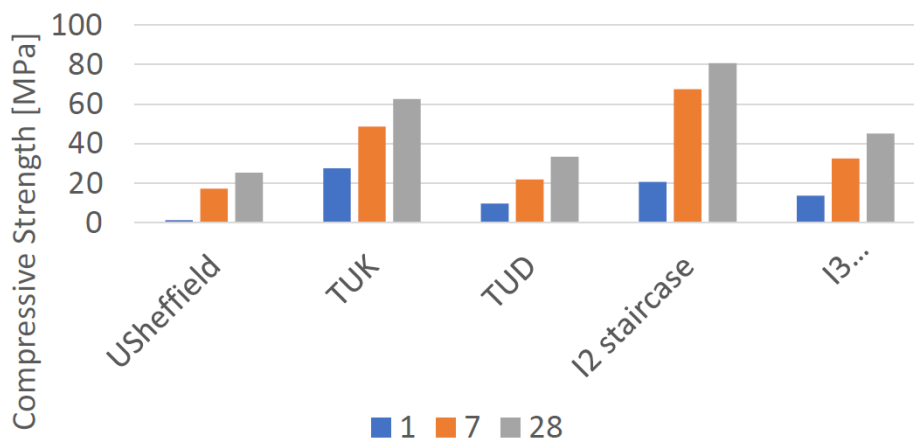

Figure 9-29 Compressive strength testing of modular bench elements

#### 9.6.4 Inverted trough concrete bench in Kaiserslautern

A reinforced concrete bench was made by one of the developed URBCON concrete mixtures at the RPTU. The views of this bench, having  $2000 \times 600 \times 450 \text{ mm}^3$  dimensions, is presented in Figure 9-30. In this bench just a fine mesh of reinforcement having 6 mm diameter with 150 mm spacing was used. The mixture that was considered for this bench was made with 100% GGBS activated by 8 % activators including sodium silicate, potassium silicate and sodium hydroxide solution. Slump value of 200 mm, obtaining 18 MPa 1-day compressive strength provided an easier and safe demoulding, and a transportation of this element after 24 hours without any special curing (Figure 9-31).

The achieved slump made also concreting and compaction easier and resulted in more beautiful and smooth concrete surface. The bench for obtaining higher strength was packed in a plastic film for two weeks. Thereafter, the wooden sitting part was set up and the whole bench placed at the lobby of building 60 of RPTU (Figure 9-32).

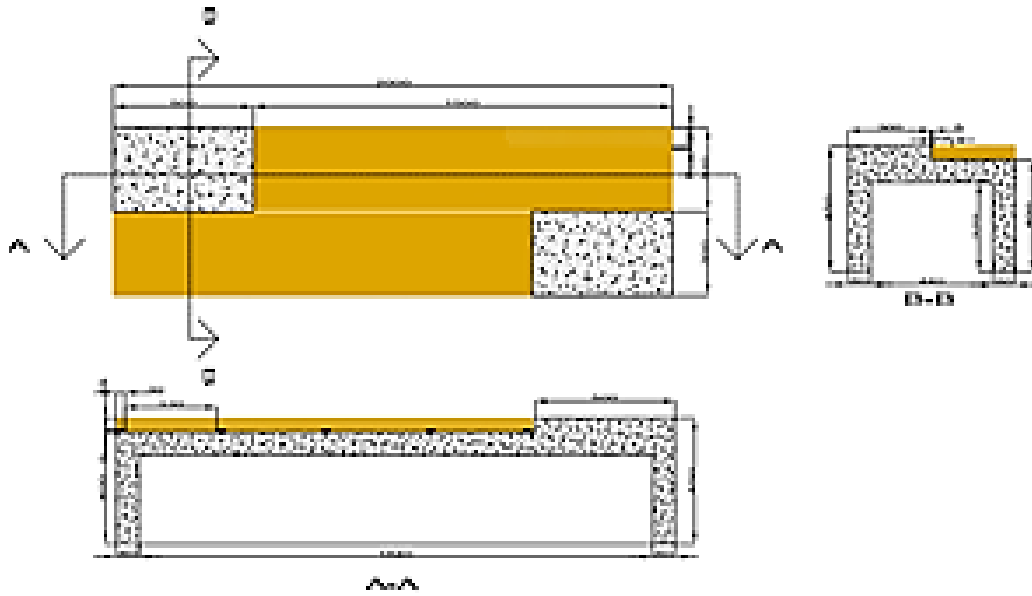

Figure 9-30 View and sections of the produced bench at RPTU

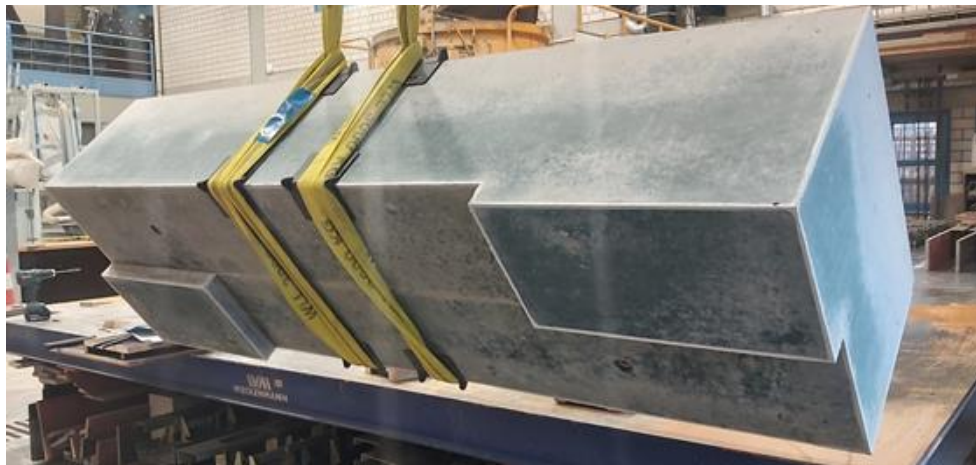

Figure 9-31 Demoulding and transporting the bench at the laboratory of RPTU



Figure 9-32 Demonstration of the URBCON bench during the 9th URBCON partner meeting

## 10 ABOUT US

### 10.1 About URBCON

Watch here the animated video about URBCON: [URBCON Animated Video](#)



#### **URBCON - By-products for sustainable concrete in the urban environment**

URBCON is an interregional project focused on innovation in circular and eco-friendly concrete technology by means of alkali-activated materials (AAMs). The project is framed more widely in fostering transnational cooperation to make Northwestern Europe a key economic player and an attractive place to work and live, with high levels of innovation, sustainability, and cohesion.

URBCON reduces the use of raw materials and the CO<sub>2</sub> emissions from construction and maintenance of buildings and infrastructure in cities, by targeting the use of AAM-based concrete as a building material. With the focus on the metropolitan areas of Ghent and Rotterdam among others, by-products such as metallic slags and incineration ashes are used as alternative raw materials to produce (almost) Portland cement free concrete. Replacing primary raw materials with by-products could save an estimated 84 million tonnes of mineral building materials per year.



The main objectives of the project are:

1. Development of concretes with 100% by-products (mineral by-product streams from make & energy industries, as well as construction and demolition waste from the construction industry) as well as with clinker-efficient cements.
2. Networking of by-product providers and construction industry by means of a web-based platform for forecasting availability and considering the logistical chains underlying the construction demand.
3. Testing of the concretes developed in the project (URBCON concretes) on the basis of three pilot projects in Ghent (street furniture and fire escape staircase in a school). Rotterdam (pedestrian bridge), and Westerlo (modular and demountable foundations of a circular office).
4. Preparation of a Strategic Technology Transfer Plan: proposals for policy frameworks, life cycle assessments. pre-normative work, economic feasibility studies.

The consortium combines world-leading know-how in by-product-based construction minerals, supplementary cementitious materials, alkali-activated binders, high-alumina cement, digital mapping of resources, and life cycle assessment and costing.

*This project has received funding from the European Union, via the Interreg North-West Europe program.*

## 10.2 About DuRSAAM

Watch here the animated video about DuRSAAM: [DuRSAAM Animated Video](#)



## **DuRSAAM - The PhD Training Network on Durable, Reliable and Sustainable Structures with Alkali-Activated Materials**

DuRSAAM is a collaborative PhD framework creating a critical mass of experts skilled in innovative alkali-activated material (AAM) concrete, as a key enabling technology for a sustainable and resilient built environment. AAM technology presents a new generation of materials, ideally conceived to respond to the need for more efficient, durable, eco-friendly, and reliable construction, and utilizing by-product resources as raw materials. Modern concrete will be produced with low carbon footprint (CO<sub>2</sub> emissions reduced by 80%), lower energy consumption and reduced use of primary resources (>1.5 t raw materials are quarried per t Portland cement clinker; this will be reduced by >60%), and with an addressable market for AAM binders of 5 B€/yr. DuRSAAM answers unmet industry demands, to facilitate emerging AAM technology for continued market entry and to unlock its potential in society.

The consortium brings together 7 academic and 15 non-academic partners, to excel in the scientific development and exploitation of AAM concrete, advancing design, modelling, and practice beyond the state-of-the-art. It holds a unique focus on: (1) today's concerns of users and engineers that the durability and sustainability of AAM concrete is yet insufficiently quantified; and (2) provision of an AAM technology for rehabilitation of structures to meet the growing demand for renovation, to be developed in parallel with AAM for new concrete structures.

DuRSAAM runs from 2018 till 2023 and delivers world-leading training in this multidisciplinary field through 13 PhDs in interrelated aspects of AAM concrete, fibre reinforced high-performance concrete, and textile-reinforced mortar, as well as sustainability assessment. The outcomes are instrumental in delivering a sustainable future in Europe's construction industry, which is increasingly driven by the growing demand for durable yet cost-effective solutions, driving a greater focus on reliable and comprehensive eco-efficient material technologies such as AAM.

*This project has received funding from the European Union's Horizon 2020 research and innovation programme under grant agreement No 813596 DuRSAAM.*

### **10.3 Project partners**

#### **URBCON project**

The City of Ghent and Ghent University are lead partners in the project, uniting 13 partners from 5 countries:

- Belgium: City of Ghent, Ghent University, ResourceFull, CWare, Kamp C and ArcelorMittal Belgium NV
- The Netherlands: Stadsontwikkeling Rotterdam, Technische Universiteit Delft, FDN Engineering
- Germany: RPTU, VDZ
- United Kingdom: University of Sheffield
- France: Imerys

#### **DuRSAAM project**

Ghent University is lead partner in the project, uniting 7 academic and 15 non-academic partners from more than 10 countries:

*Academic partners:*

- Ghent University
- TU Delft
- Karlsruhe Institute of Technology
- University of Sheffield
- University of Zagreb
- University of Patras
- ETH Zürich

*Industrial/associated partners:*

- Cement Roadstone Holding (CRH)
- CWare
- T.ΕΠΙ.ΚΑΤ
- Aurubis
- SANACON
- ARGOS
- City of Ghent
- Flemish department for mobility and public works (MOW)
- ResourceFull
- FDN Engineering
- Owens Corning Int.
- Gemeente Rotterdam
- Bekaert
- ArcelorMittal
- Gradmont
- Holcim Lafarge

## REFERENCES

- [1] D. Bjegovic, N. Steimer, M. Serdar, “Sustainable concrete production”, *Concr. Plant Int.*, 3, 2011, pp. 78–83.
- [2] J.G.J. Olivier, G. Janssens-Maenhout, M. Muntean, J. Peters, *Trends in global CO<sub>2</sub> emissions: 2012 Report*, Joint Research Centre, Institute for Environment and Sustainability, Netherlands, 2013, doi: 10.2788/33777.
- [3] ECTP, *Challenging and Changing Europe’s Built Environment - A vision for a sustainable and competitive construction sector by 2030.*, European Construction Technology Platform, 2005.
- [4] European Union, *Strategy for the sustainable competitiveness of the construction sector and its enterprises*, European Economic and Social Committee, 2013, CCMI/106-EESC-2012-2295.
- [5] J. L. Provis, J.S.J. van Deventer, *Alkali Activated Materials, State-of-the-Art Report RILEM TC 224-AAM*, 2014.
- [6] P. Duxson, A. Fernández-Jiménez, J.L. Provis, G.C. Lukey, A. Palomo, J.S.J. Van Deventer, “Geopolymer technology: The current state of the art”, *J. Mater. Sci.*, 42, 2007, pp. 2917–2933.
- [7] J.S.J. Van Deventer, “Progress in the Adoption of Geopolymer Cement”, Chapter 10 of *Handbook of Low Carbon Concrete*, 2017, pp. 217-262, doi: 10.1016/B978-0-12-804524-4.00010-5.
- [8] S. A. Bernal, R. San Nicolas, J.L. Provis, R. Mejía De Gutiérrez, J.S.J. Van Deventer, “Natural carbonation of aged alkali-activated slag concretes”, *Mater. Struct. Constr.*, 47, 2014, pp. 693–707.
- [9] S. Aydin, B. Baradan, “Engineering properties of reactive powder concrete without Portland cement”, *ACI Mater. J.*, 110, 2013, pp. 619–627.
- [10] S. Aydin, B. Baradan, “Effect of activator type and content on properties of alkali-activated slag mortars”, *Compos. Part B Eng.*, 57, 2014, pp. 166–172.
- [11] G. Ye, M. Luković, B. Ghiassi, Z. Aldin, S. Prinsse, J. Liu, et al., “Geocon bridge geopolymer concrete mixture for structural applications”, *Spool*, 6(2), 2019, pp. 21–26, doi: 10.7480/spool.2019.2.4369.
- [12] M.I.A. Aleem, P.D. Arumairaj, “Geopolymer concrete—a review”, *Int. J. Eng. Sci. Emerg. Technol*, 1, 2012, pp. 118–122.
- [13] G.P. Hammond, C.I. Jones, “Embodied energy and carbon in construction materials”, *Proc. Inst. Civ. Eng.*, 161, 2008, pp. 87–98.
- [14] B.V.V. Reddy, K.S. Jagadish, “Embodied energy of common and alternative building materials and technologies”, *Energy Build.*, 35, 2003, pp. 129–137.

- [15] IEA, Cement Technology Roadmap 2009: carbon emissions reductions up to 2050, Int. Energy Agency, 2009, Available: <https://www.iea.org/reports/cement-technology-roadmap-carbon-emissions-reductions-up-to-2050>.
- [16] A. Sivakrishna, A. Adesina, P.O. Awoyera, K.R. Kumar, "Green concrete: A review of recent developments", *Mater. Today Proc.*, 27, 2020, pp. 54–58, doi: 10.1016/j.matpr.2019.08.202.
- [17] J. de Brito, R. Kurda, "The past and future of sustainable concrete: A critical review and new strategies on cement-based materials", *J. Clean. Prod.*, 281, 2021, 123558.
- [18] J.S. Damtoft, J. Lukasik, D. Herfort, D. Sorrentino, E.M. Gartner, "Sustainable development and climate change initiatives", *Cem. Concr. Res.*, 38, 2008, pp. 115–127, doi: 10.1016/j.cemconres.2007.09.008
- [19] S.A. Miller, V.M. John, S.A. Pacca, A. Horvath, "Carbon dioxide reduction potential in the global cement industry by 2050", *Cem. Concr. Res.*, 114, 2018, pp. 115–124.
- [20] W.-J. Du, Q. Yin, L. Cheng, "Experiments on novel heat recovery systems on rotary kilns", *Appl. Therm. Eng.*, 139, 2018, pp. 535–541.
- [21] T. Engin, V. Ari, "Energy auditing and recovery for dry type cement rotary kiln systems—A case study", *Energy Convers. Manag.*, 46, 2005, pp. 551–562.
- [22] V. Karamarković, M. Marašević, R. Karamarković, M. Karamarković, "Recuperator for waste heat recovery from rotary kilns", *Appl. Therm. Eng.*, 54, 2013, pp. 470–480.
- [23] P. Duxson, J.L. Provis, G.C. Lukey, J.S.J. Van Deventer, "The role of inorganic polymer technology in the development of 'green concrete'", *Cem. Concr. Res.*, 37, 2007, pp. 1590–1597, doi: 10.1016/j.cemconres.2007.08.018.
- [24] K.M. Liew, A.O. Sojobi, L.W. Zhang, "Green concrete: Prospects and challenges", *Constr. Build. Mater.*, 156, 2017, pp. 1063–1095.
- [25] M. Serdar, D. Bjegovic, N. Stirmer, I. Banjad Pecur, "Alternative binders for concrete: opportunities and challenges", *Proceedings Scientific Symposium 'Future Trends in Civil Engineering'*, Univ. Zagreb, 2019, pp. 199–218, doi: 10.5592/co/ftce.2019.09.
- [26] M.A. Mirzakhani, N. Tahouni, M.H. Panjeshahi, "Energy benchmarking of cement industry, based on Process Integration concepts", *Energy.*, 130, 2017, pp. 382–391.
- [27] M.U. Hossain, C.S. Poon, I.M.C. Lo, J.C.P. Cheng, "Comparative LCA on using waste materials in the cement industry: A Hong Kong case study", *Resour. Conserv. Recycl.*, 120, 2017, pp. 199–208.
- [28] S. Karellas, A.-D. Leontaritis, G. Panousis, E. Bellos, E. Kakaras, "Energetic and exergetic analysis of waste heat recovery systems in the cement industry", *Energy.*, 58, 2013, pp. 147–156.
- [29] R. Kajaste, M. Hurme, "Cement industry greenhouse gas emissions—management options and abatement cost", *J. Clean. Prod.*, 112, 2016, pp. 4041–4052.
- [30] R. Latawiec, P. Woyciechowski, K.J. Kowalski, "Sustainable concrete performance—CO<sub>2</sub>-emission", *Environments.*, 5, 2018, 27p.
- [31] A.J. Schokker (Ed.), *The Sustainable Concrete Guide: Applications*, U.S. Green Concrete Council, 2010.
- [32] CEMBUREAU, *Domestic deliveries of cement types and strength: Cembureau countries – synthesis 2019*, European Cement Association, 2019.
- [33] F. Canonico, L. Capelli, D. Gastaldi, L. Buzzi, "Charakterisierung und technische Eigenschaften von CSA-Hochleistungsklinker", *Zement-Kalk-Gips*, 4, 2013, pp. 54–64.
- [34] F. Glasser und L. Zhang, "High-performance cement matrices based on calcium sulfoaluminate-belite compositions", *Cement and Concrete Research*, 31(12), 2001, pp. 1881–1886.



- [35] F. Canonico, G. Bernardo, L. Buzzi, M. Paris, A. Telesca und G. Valenti, "Microstructural investigations on hydrated high-performance cements based on calcium sulfoaluminate", Proc. 12th International Congress on the Chemistry of Cement, ICCM, Montreal, 2007, 12p.
- [36] J. Stark, B. Wicht, "Zement und Kalk - Der Baustoff als Werkstoff", Basel: Birkhäuser Verlag, 2000.
- [37] V. Zivica, I. Janotka, J. Majling, "Chemical resistance of the hydration products of C4A3S", World cement, 28(12), 1997, pp. 80-82.
- [38] A. Mesbah, C. Cau-dit-Coumes, G. Renaudin, F. Frizon, F. Leroux, "Uptake of chloride and carbonate ions by calcium monosulfoaluminate hydrate", Cem. Concr. Res., 42 (8), 2012, pp. 1157-1165.
- [39] D. Zhang, D. Xu, X. Cheng, W. Chen, "Carbonation resistance of sulphoaluminate cement-based high performance concrete". Wuhan-University of Technology and Materials: Journal, Scientific Edition 4, 2009, pp. 663-666.
- [40] F. Canonico, P. Schäffel, L. Buzzi, "Durability properties of concrete made with industrial CSA cement", Proceedings ICDC Trondheim, 2012.
- [41] P. Hewlett, L. Martin (Eds.), Lea's chemistry of cement and concrete. Butterworth-Heinemann, 2019, ISBN: 9780081007952.
- [42] B. Lothenbach, K. Scrivener, R.D. Hooton, "Supplementary cementitious materials", Cem. Concr. Res., 41, 2011, pp. 1244-1256.
- [43] M.C.G. Juenger, R. Snellings, S.A. Bernal, "Supplementary cementitious materials: New sources, characterization, and performance insights", Cem. Concr. Res., 122, 2019, pp. 257-273.
- [44] M. Sharma, S. Bishnoi, F. Martirena, K. Scrivener, "Limestone calcined clay cement and concrete: A state-of-the-art review", Cem. Concr. Res., 149, 2021, #106564.
- [45] E. Aprianti, P. Shafiqh, S. Bahri, J.N. Farahani, "Supplementary cementitious materials origin from agricultural wastes—A review", Constr. Build. Mater., 74, 2015, pp. 176-187.
- [46] R. Snellings, "Assessing, Understanding and Unlocking Supplementary Cementitious Materials", RILEM Tech Lett, 1, 2016, pp. 50-55, doi: 10.21809/rilemtechlett.2016.12.
- [47] H.F.W. Taylor, "Nanostructure of C-S-H: Current status", Adv. Cem. Based Mater., 1, 1993, pp. 38-46.
- [48] X. Pardal, I. Pochard, A. Nonat, "Experimental study of Si-Al substitution in calcium-silicate-hydrate (CSH) prepared under equilibrium conditions", Cem. Concr. Res., 39, 2009, pp. 637-643.
- [49] C.-P. Anke, H. Hobbie, S. Schreiber, D. Möst, "Coal phase-outs and carbon prices: Interactions between EU emission trading and national carbon mitigation policies", Energy Policy., 144, 2020, #111647.
- [50] R. Maddalena, J.J. Roberts, A. Hamilton, "Can Portland cement be replaced by low-carbon alternative materials? A study on the thermal properties and carbon emissions of innovative cements", J. Clean. Prod., 186, 2018, pp. 933-942.
- [51] A. Herrmann, A. Koenig, F. Dehn, "Structural concrete based on alkali-activated binders: Terminology, reaction mechanisms, mix designs and performance", Struct. Concr., 19, 2018, pp. 918-929, doi: 10.1002/suco.201700016.
- [52] M. Pepe, R.D. Toledo Filho, E.A.B. Koenders, E. Martinelli, "Alternative processing procedures for recycled aggregates in structural concrete", Construction and Building Materials, 69, 2014, pp. 124-132, doi: 10.1016/j.conbuildmat.2014.06.084.
- [53] Aggregates Advisory Service, China clay by-products as aggregates, Digest no. 055 (2:1/99), Available: <https://p2infohouse.org/ref/17/16597.pdf>.

- [54] Fortune Business Insights, The Europe construction aggregates market 2022-2027, FBI market research report 104698 (+ public summary), 2021, Available: <https://www.fortunebusinessinsights.com/europe-construction-aggregates-market-104698>.
- [55] M. Batayneh, I. Marie, I. Asi, "Use of selected waste materials in concrete mixes", *Waste Manag*, 27(12), 2007, pp. 1870–6, doi: 10.1016/j.wasman.2006.07.026.
- [56] K. Kishore, N. Gupta, "Application of domestic & industrial waste materials in concrete: A review", *Materials Today: Proceedings*, 26, 2020, pp. 2926-31, doi: 10.1016/j.matpr.2020.02.604.
- [57] S. Pourkhorshidi, C. Sangiorgi, D. Torreggiani, P. Tassinari, "Using recycled aggregates from construction and demolition waste in unbound layers of pavements", *Sustainability*, 12, 2020, #9386, doi: 10.3390/su12229386.
- [58] European Environment Agency, The Case for Increasing Recycling - Estimating the Potential for Recycling in Europe, European Union, 2020.
- [59] P. Kurth, A. Oexle, *Praxishandbuch der Kreislauf- und Rohstoffwirtschaft*, Springer vieweg. Berlin, Köln, 2017.
- [60] EK. Lauritzen, "The global challenge of recycled concrete In: Sustainable Construction: Use of Recycled Concrete Aggregate", *Proceedings Int. Symp. by Concrete Technology Unit and University of Dundee*, 11–12 November 1998, London, UK, Thomas Telford Publishing, 1998, pp. 505–519.
- [61] A. Müller, *Baustoffrecycling Wiesbaden*, Springer Fachmedien Wiesbaden, 2018.
- [62] A. Akhtar, AK .Sarmah, "Construction and demolition waste generation and properties of recycled aggregate concrete: A global perspective", *J. Clean. Prod.*, 186, 2018, pp. 262–281.
- [63] A. Teara, D.S. Ing, V.W.Y. Tam, "The use of waste materials for concrete production in construction applications", *IOP Conference Series: Materials Science and Engineering*, 342, 2018, doi: 10.1088/1757-899X/342/1/012062.
- [64] KH. Mo, UJ. Alengaram, MZ. Jumaat, SP. Yap, SC. Lee, "Green concrete partially comprised of farming waste residues: a review", *Journal of Cleaner Production*, 117, 2016, pp. 122–38.
- [65] A. Müller, "Aufbereiten und Verwerten von Bauabfällen – aktueller Stand und Ausblick", *Bauhaus-Universität Weimar, Fachtagung Recycling*, Weimar, 2003.
- [66] BBSE, *Konjunkturperspektiven ab 2006 bis 2016*, Bundesverband Baustoffe-Steine und Erden e.V., Berlin, 2017.
- [67] BK-i, *Festschrift des Bundesverbandes der Kalksandsteinindustrie*, Bundesverband der Kalksandstein-industrie, Hannover, 1994.
- [68] K. Rahlwes, "Wiederverwendung von Baustoffen im Hochbau", 32. Darmstädter Seminar Abfall-technik, Schriftenreihe WAR der Technischen Universität Darmstadt, Band 67, 1993, pp. 120-141.
- [69] B. Gómez-Meijide, I. Pérez, A.R. Pasandín, "Recycled construction and demolition waste in Cold Asphalt Mixtures: Evolutionary properties", *J. Clean. Prod.*, 112, 2016, pp. 588–598.
- [70] Verian K. P., Ashraf W., Cao Y., "Properties of recycled concrete aggregate and their influence in new concrete production", *Resources, Conservation & Recycling*, 133, 2018, pp. 30-49.
- [71] ArcelorMittal, "More than steel", By-products ArcelorMittal, Accessed March 2023: <https://corporate.arcelormittal.com/industries/by-product>.
- [72] H. Bodo Längen, *Wege zur Minderung von CO<sub>2</sub>-Emissionen in der Eisen- und Stahlindustrie in Europa*, Stahlinstitut VDEh, Düsseldorf, 2021, Available: [https://www.vdeh.de/media/2021-03-30\\_luengen\\_wege\\_zur\\_minderung\\_von\\_co2-emissionen.pdf](https://www.vdeh.de/media/2021-03-30_luengen_wege_zur_minderung_von_co2-emissionen.pdf).

- [73] Thyssenkrupp, “Future of steel production starts now”, Thyssenkrupp – climate strategy steel, Accessed March 2023: <https://www.thyssenkrupp-steel.com/en/company/sustainability/climate-strategy/>.
- [74] Salcos, “Salzgitter Low CO2 Steelmaking”, Salcos - we make steel green, Accessed March 2023: <https://salcos.salzgitter-ag.com/en/salcos.html>.
- [75] ArcelorMittal, “ArcelorMittal Europe to produce ‘green steel’ starting in 2020”, ArcelorMittal news article, Accessed March 2023: <https://corporate.arcelormittal.com/media/news-articles/arcelormittal-europe-to-produce-green-steel-starting-in-2020>.
- [76] T. Reiche, A. Ehrenberg, D. Algermissen, “Transformation der Stahlindustrie und Herausforderungen für die Wertschöpfungskette Schlacke”, 35 Aachener Stahlkolloquium, 23-24.09.2021, Aachen, 2021.
- [77] D. Mamurekli, “Environmental impacts of coal mining and coal utilization in the UK”, *Acta Montanistica Slovaca*, 15(2), 2010.
- [78] Imerys, “Embedding sustainable thinking into everything we do”, Imerys - our commitment to sustainability, Accessed March 2023: <https://www.imerys.com/group/our-group/sustainability>.
- [79] V. N. Dwivedi, N. P. Singh, S. S. Das, N. B. Singh, “A new pozzolanic material for cement industry: Bamboo leaf ash”, *Int. Journal of Physical Sciences*, 1, 2006, pp. 106–111.
- [80] E. Villar-Cociña, E.V. Morales, S.F. Santos, H. Savastano, M. Frías, “Pozzolanic behavior of bamboo leaf ash: Characterization and determination of the kinetic parameters”, *Cement and Concrete Composites*, 33(1), 2011, pp. 68–73, doi: 10.1016/j.cemconcomp.2010.09.003.
- [81] X. Xie, Z. Zhou, M. Jiang, X. Xu, Z. Wang, D. Hui, “Cellulosic fibers from rice straw and bamboo used as reinforcement of cement-based composites for remarkably improving mechanical properties”, *Composites Part B: Engineering* 78, 2015, pp. 153–61, doi: 10.1016/j.compositesb.2015.03.086
- [82] B. Belhadj, M. Bederina, N. Montrelay, J. Houessou, M. Quéneudec, “Effect of substitution of wood shavings by barley straws on the physico-mechanical properties of lightweight sand concrete”, *Construction and Building Materials*, 66, 2014, pp. 247–58, doi: 10.1016/j.conbuildmat.2014.05.090
- [83] H. Binici, F. Yuçegok, O. Aksogan, H. Kaplan “Effect of Corncob, Wheat Straw, and Plane Leaf Ashes as Mineral Admixtures on Concrete Durability”, *Materials in civil engineering*, 20, 2008, pp. 478–83.
- [84] P. Duxson, J. L. Provis, “Designing precursors for geopolymer cements”, *J. Am. Ceram. Soc.*, 91(12), 2008, pp. 3864–3869, doi: 10.1111/j.1551-2916.2008.02787.x.
- [85] N. Li, C. Shi, Z. Zhang, H. Wang, Y. Liu, “A review on mixture design methods for geopolymer concrete”, *Compos. Part B Eng.*, 178, 2019, #107490, doi: 10.1016/j.compositesb.2019.107490.
- [86] R. Snellings, “Solution-controlled dissolution of supplementary cementitious material glasses at pH 13: The effect of solution composition on glass dissolution rates”, *J. Am. Ceram. Soc.*, 96(8), 2013, pp. 2467–2475, doi: 10.1111/jace.12480.
- [87] K. C. Newlands, D. E. Macphee, “The reactivity of aluminosilicate glasses in cements—effects of Ca content on dissolution characteristics and surface precipitation”, *Adv. Appl. Ceram.*, 116(4), 2017, pp. 216–224, doi: 10.1080/17436753.2017.1299986.
- [88] M. Ben Haha, G. Le Saout, F. Winnefeld, B. Lothenbach, “Influence of activator type on hydration kinetics, hydrate assemblage and microstructural development of alkali activated

- blast-furnace slags”, *Cem. Concr. Res.*, 41(3), 2011, pp. 301-310, doi: 10.1016/j.cemconres.2010.11.016.
- [89] I. Garcia-Lodeiro, A. Palomo, A. Fernández-Jiménez, “An overview of the chemistry of alkali-activated cement-based binders”, *Handbook of Alkali-Activated Cements, Mortars and Concretes*, Woodhead Publishing Limited, 2015.
- [90] I. G. Richardson, G. W. Groves, “Microstructure and microanalysis of hardened cement pastes involving ground granulated blast-furnace slag”, *J. Mater. Sci.*, 27(22), 1992, pp. 6204–6212, doi: 10.1007/BF01133772.
- [91] R. J. Myers, S. A. Bernal, J. L. Provis, “A thermodynamic model for C-(N-)A-S-H gel: CNASH-ss. Derivation and validation”, *Cem. Concr. Res.*, 66, 2014, pp. 27–47, doi: 10.1016/j.cemconres.2014.07.005.
- [92] H. F. W. Taylor, “Nanostructure of CSH: Current status”, *Adv. Cem. Based Mater.*, 1, 1993, pp. 38-46, doi: 10.1016/1065-7355(93)90006-A.
- [93] F. Puertas, M. Palacios, H. Manzano, J. S. Dolado, A. Rico, J. Rodríguez, “A model for the C-A-S-H gel formed in alkali-activated slag cements”, *J. Eur. Ceram. Soc.*, 31(12), 2011, pp. 2043–2056, doi: 10.1016/j.jeurceramsoc.2011.04.036.
- [94] D. Damidot, B. Lothenbach, D. Herfort, F. P. Glasser, “Thermodynamics and cement science”, *Cem. Concr. Res.*, 41(7), 2011, 679–695, doi: 10.1016/j.cemconres.2011.03.018.
- [95] I. G. Richardson, A. R. Brough, R. Brydson, G. W. Groves, C. M. Dobson, “Location of aluminium in substituted calcium silicate hydrate (C-S-H) gels as determined by Si-29 and Al-27 NMR and EELS”, *J. Am. Ceram. Soc.*, 76(9), 1993, pp. 2285–2288.
- [96] B. Lothenbach, T. Matschei, G. Möschner, F. P. Glasser, “Thermodynamic modelling of the effect of temperature on the hydration and porosity of Portland cement”, *Cem. Concr. Res.*, 38(1), 2008, pp. 1–18, doi: 10.1016/j.cemconres.2007.08.017.
- [97] S. A. Bernal, J. L. Provis, V. Rose, R. Mejía De Gutierrez, “Evolution of binder structure in sodium silicate-activated slag-metakaolin blends”, *Cem. Concr. Compos.*, 33(1), 2011, pp. 46–54, 2011, doi: 10.1016/j.cemconcomp.2010.09.004.
- [98] S. Grangeon, A. Fernandez-Martinez, A. Baronnet, N. Marty, A. Poulain, E. Elkaïm, C. Roosz, S. Gaboreau, P. Henocq, F. Claret, “Quantitative X-ray pair distribution function analysis of nanocrystalline calcium silicate hydrates: A contribution to the understanding of cement chemistry”, *J. Appl. Crystallogr.*, 50(1), 2017, pp. 14–21, doi: 10.1107/S1600576716017404.
- [99] C. E. White, J. L. Provis, B. Bloomer, N. J. Henson, K. Page, “In situ X-ray pair distribution function analysis of geopolymer gel nanostructure formation kinetics”, *Phys. Chem. Chem. Phys.*, 15(22), 2013, pp. 8573–8582, doi: 10.1039/c3cp44342f.
- [100] M. Criado, A. Fernández-Jiménez, A. Palomo, “Alkali activation of fly ash: Effect of the SiO<sub>2</sub>/Na<sub>2</sub>O ratio. Part I: FTIR study”, *Microporous Mesoporous Mater.*, 106(1–3), 2007, pp. 180–191, doi: 10.1016/j.micromeso.2007.02.055.
- [101] A. Fernández-Jiménez A. Palomo, “Composition and microstructure of alkali activated fly ash binder: Effect of the activator”, *Cem. Concr. Res.*, 35 (10), 2005, pp. 1984–1992, doi: 10.1016/j.cemconres.2005.03.003.
- [102] I. Garcia-Lodeiro, A. Palomo, A. Fernández-Jiménez, D. E. MacPhee, “Compatibility studies between N-A-S-H and C-A-S-H gels. Study in the ternary diagram Na<sub>2</sub>O-CaO-Al<sub>2</sub>O<sub>3</sub>-SiO<sub>2</sub>-H<sub>2</sub>O”, *Cement and Concrete Research*, 41(9), 2011, pp. 923–931, doi: 10.1016/j.cemconres.2011.05.006.
- [103] X. Zhao, C. Liu, L. Zuo, L. Wang, Q. Zhu, M. Wang, “Investigation into the effect of calcium on the existence form of geopolymerized gel product of fly ash based geopolymers”, *Cem. Concr. Compos.*, 103, 2019, pp. 279–292, doi: 10.1016/j.cemconcomp.2018.11.019.

- [104] S. Puligilla, X. Chen, P. Mondal, "Does synthesized C-S-H seed promote nucleation in alkali activated fly ash-slag geopolymer binder?", *Mater. Struct. Constr.*, 52(4), 2019, pp. 1–13, doi: 10.1617/s11527-019-1368-3.
- [105] T. Bakharev, "Geopolymeric materials prepared using Class F fly ash and elevated temperature curing", *Cem. Concr. Res.*, 35(6), 2005, pp. 1224–1232, doi: 10.1016/j.cemconres.2004.06.031.
- [106] F. Winnefeld, A. Leemann, M. Lucuk, P. Svoboda, M. Neuroth, "Assessment of phase formation in alkali activated low and high calcium fly ashes in building materials", *Constr. Build. Mater.*, 24(6), 2010, pp. 1086–1093, doi: 10.1016/j.conbuildmat.2009.11.007.
- [107] A. Tuinukuafe, T. Kaub, C. A. Weiss, P. G. Allison, G. B. Thompson, A. Amirkhanian, "Atom probe tomography of an alkali activated fly ash concrete", *Cem. Concr. Res.*, 121, 2019, pp. 37–41, doi: 10.1016/j.cemconres.2019.04.007.
- [108] P. Rožek, M. Król, W. Mozgawa, "Geopolymer-zeolite composites: A review", *J. Clean. Prod.*, 230, 2019, pp. 557–579, doi: 10.1016/j.jclepro.2019.05.152.
- [109] B. Ma, B. Lothenbach, "Synthesis, characterization, and thermodynamic study of selected Na-based zeolites", *Cem. Concr. Res.*, 135, 2020, #106111, doi: 10.1016/j.cemconres.2020.106111.
- [110] M. Komljenović, Z. Baščarević, V. Bradić, "Mechanical and microstructural properties of alkali-activated fly ash geopolymers", *J. Hazard. Mater.*, 181(1–3), 2010, pp. 35–42, doi: 10.1016/j.jhazmat.2010.04.064.
- [111] W. Mozgawa, M. Król, "FT-IR studies of zeolites from different structural groups", *Chemik* 65.7, 2011, pp. 667-674.
- [112] H. R. Khalid, N. K. Lee, I. Choudhry, Z. Wang, H. K. Lee, "Evolution of zeolite crystals in geopolymer-supported zeolites: effects of composition of starting materials", *Mater. Lett.*, 239, 2019, pp. 33–36, doi: 10.1016/j.matlet.2018.12.044.
- [113] G. Kovalchuk, A. Fernández-Jiménez, A. Palomo, "Alkali-activated fly ash: Effect of thermal curing conditions on mechanical and microstructural development - Part II", *Fuel*, 86(3), 2007, pp. 315–322, doi: 10.1016/j.fuel.2006.07.010.
- [114] Y. Zuo, M. Nedeljković, G. Ye, "Pore solution composition of alkali-activated slag/fly ash pastes", *Cem. Concr. Res.*, 115, 2019, pp. 230-250, doi: 10.1016/j.cemconres.2018.10.010.
- [115] J. Temuujin, A. Minjigmaa, W. Rickard, M. Lee, I. Williams, A. van Riessen, "Fly ash based geopolymer thin coatings on metal substrates and its thermal evaluation", *J. Hazard. Mater.*, 180(1–3), 2010, pp. 748–752, doi: 10.1016/j.jhazmat.2010.04.121.
- [116] W. Mozgawa, W. Jastrzębski, M. Handke, "Vibrational spectra of D4R and D6R structural units", *J. Molecular Structure*, 744-747, 2005, pp. 663-670, doi: 10.1016/j.molstruc.2004.12.051.
- [117] W. Zhu, X. Chen, L. J. Struble, E. H. Yang, "Quantitative characterization of aluminosilicate gels in alkali-activated incineration bottom ash through sequential chemical extractions and deconvoluted nuclear magnetic resonance spectra", *Cem. Concr. Compos.*, 99, 2019, pp. 175–180, doi: 10.1016/j.cemconcomp.2019.03.014.
- [118] I. Ismail, S. A. Bernal, J. L. Provis, R. San Nicolas, S. Hamdan, J. S. J. Van Deventer, "Modification of phase evolution in alkali-activated blast furnace slag by the incorporation of fly ash", *Cem. Concr. Compos.*, 45, 2014, pp. 125–135, doi: 10.1016/j.cemconcomp.2013.09.006.
- [119] M. Criado, A. Fernández-Jiménez, A. G. de la Torre, M. A. G. Aranda, A. Palomo, "An XRD study of the effect of the SiO<sub>2</sub>/Na<sub>2</sub>O ratio on the alkali activation of fly ash", *Cem. Concr. Res.*, 37(5), 2007, pp. 671–679, doi: 10.1016/j.cemconres.2007.01.013.



- [120] Z. Sun, A. Vollpracht, “One year geopolymerisation of sodium silicate activated fly ash and metakaolin geopolymers”, *Cem. Concr. Compos.*, 95, 2019, pp. 98–110, doi: 10.1016/j.cemconcomp.2018.10.014.
- [121] J. E. Oh, P. J. M. Monteiro, S. S. Jun, S. Choi, S. M. Clark, “The evolution of strength and crystalline phases for alkali-activated ground blast furnace slag and fly ash-based geopolymers”, *Cem. Concr. Res.*, 40(2), 2010, pp. 189–196, doi: 10.1016/j.cemconres.2009.10.010.
- [122] G. V. P. Bhagath Singh, K. V. L. Subramaniam, “Quantitative XRD study of amorphous phase in alkali activated low calcium siliceous fly ash”, *Constr. Build. Mater.*, 124, 2016, pp. 139–147, doi: 10.1016/j.conbuildmat.2016.07.081.
- [123] C. Ouellet-Plamondon, G. Habert, “Life cycle assessment (LCA) of alkali-activated cements and concretes”, *Handbook of Alkali-Activated Cements, Mortars and Concretes*, Woodhead Publishing Limited (2015).
- [124] M. D. A. Thomas, “Optimizing the Use of Fly Ash in Concrete”, *Portl. Cem. Assoc.*, 2007, 24p.
- [125] C. Heidrich, H. Feuerborn, A. Weir, “Coal Combustion Products: a Global Perspective”, 2013 World of Coal Ash (WOCA) Conference, April 22-25, 2013 in Lexington, KY.
- [126] R. T. Chancey, P. Stutzman, M. C. G. Juenger, D. W. Fowler, “Comprehensive phase characterization of crystalline and amorphous phases of a Class F fly ash”, *Cem. Concr. Res.*, 40(1), 2010, pp. 146–156, doi: 10.1016/j.cemconres.2009.08.029.
- [127] World Steel Association, “Steel facts,” 2018.
- [128] J. L. Provis, S. A. Bernal, “Geopolymers and Related Alkali-Activated Materials”, *Annu. Rev. Mater. Res.*, 44(1), 2014, pp. 299–327, doi: 10.1146/annurev-matsci-070813-113515.
- [129] T. Bakharev, J. G. Sanjayan, Y. B. Cheng, “Effect of admixtures on properties of alkali-activated slag concrete”, *Cem. Concr. Res.*, 2000, doi: 10.1016/S0008-8846(00)00349-5.
- [130] A. Fernández-Jiménez, F. Puertas, I. Sobrados, J. Sanz, “Structure of calcium silicate hydrates formed in alkaline-activated slag: Influence of the type of alkaline activator”, *J. Am. Ceram. Soc.*, 86(8), 2003, pp. 1389–1394, doi: 10.1111/j.1151-2916.2003.tb03481.x.
- [131] I. Garcia-lodeiro, A. Palomo, “Effect of calcium on the alkaline activation of aluminosilicate glass”, *Ceram. Int.*, 42(6), 2016, pp. 7697–7707, doi: 10.1016/j.ceramint.2016.01.184.
- [132] S. A. Bernal, J.L. Provis, B. Walkley, R. San Nicolas, J. D. Gehman, D. G. Brice, A. R. Kilcullen, P. Duxson, J. S.J. van Deventer, “Gel nanostructure in alkali-activated binders based on slag and fly ash, and effects of accelerated carbonation”, *Cem. Concr. Res.*, 53, 2013, pp. 127–144, doi: 10.1016/j.cemconres.2013.06.007.
- [133] B. Looney, “Statistical Review of World Energy globally consistent data on world energy markets and authoritative publications in the field of energy”, *Rev. World Energy data*, 70, 2021, pp. 8–20.
- [134] IEA, *Global Energy Review 2020*, Int. Energy Agency, 2020, doi: 10.1787/a60abbf2-en
- [135] IEA, *Coal 2022*, Int. Energy Agency (2022). <https://www.iea.org/reports/coal-2022>
- [136] WSA, *Steel statistical yearbook 2020*, World Steel Association, 2020.
- [137] K. Czigler, T. Reiter, S. Schulze, P. Somers, “Laying the foundation for zero-carbon cement”, *McKinsey Co. Chem. Pract.*, 40(2), 2020, p. 48.
- [138] Accenture, “Steel Demand Beyond 2030”, *Steel Demand Beyond 2030 – Forecast Scenar.*, 2017, pp. 24–25, Available at: [https://www.oecd.org/industry/ind/Item\\_4b\\_Accenture\\_Timothy\\_van\\_Audenaerde.pdf](https://www.oecd.org/industry/ind/Item_4b_Accenture_Timothy_van_Audenaerde.pdf).
- [139] A. Favier, C. De Wolf, K. Scrivener, G. Habert, *A sustainable future for the European cement and Technology assessment for full decarbonisation of the industry by 2050*, ETH Zurich, 2019, doi: 10.3929/ethz-b-000301843.



- [140] T. C. Alex, A. M. Kalinkin, S. K. Nath, B.I. Gurevich, E. V. Kalinkina, V. V. Tyukavkina, S. Kumar, "Utilization of zinc slag through geopolymerization: Influence of milling atmosphere", *International Journal of Mineral Processing*, 123, 2013, pp. 102–107, doi: 10.1016/j.minpro.2013.06.001.
- [141] S. Amiralian, M. A. Budihardjo, A. Chegenizadeh, H. Nikraz, "Study of scale effect on strength characteristic of stabilised composite with sewage sludge – Part B : Critical investigation", *Construction and Building Materials*, 80, 2015, pp. 346–350, doi: 10.1016/j.conbuildmat.2015.01.070.
- [142] A. Bagheri, S. Moukannaa, "A new approach to the reuse of waste glass in the production of alkali-activated materials", *Cleaner Engineering and Technology*, 2021, #100212, doi: 10.1016/j.clet.2021.100212.
- [143] S. A. Bernal, E. D Rodríguez, A. P. Kirchheim, J. L. Provis, "Management and valorisation of wastes through use in producing alkali-activated cement materials", *Journal of Chemical Technology and Biotechnology*, 2016, pp. 2365–2388, doi: 10.1002/jctb.4927.
- [144] J. Bollen, "Slags valorization in the EU: tapping the full potential", in *6th International Slag Valorisation Symposium*, 2019, pp. 35–41.
- [145] S. Caijun, L. Yinyu, "Investigation on some factors affecting the characteristics of alkali-phosphorus slag cement", *Cement and Concrete Research*, 19(4), 1989, pp. 527–533, doi: 10.1016/0008-8846(89)90004-5.
- [146] V. N. Castaldelli, J. L. Akasaki, J. L.P. Melges, M. M. Tashima, L. Soriano, M. V. Borrachero, J. Monzó, J. Payá, "Use of slag/sugar cane bagasse ash (SCBA) blends in the production of alkali-activated materials", *Materials*, 6(8), 2013, pp. 3108–3127, doi: 10.3390/ma6083108.
- [147] M. Criado, X. Ke, J. L. Provis, S. A. Bernal, "7 - Alternative inorganic binders based on alkali-activated metallurgical slags", *Sustainable and Nonconventional Construction Materials using Inorganic Bonded Fiber Composites*, 2017, pp. 185–220, doi: 10.1016/B978-0-08-102001-2.00008-5.
- [148] FOA, FAOSTAT, Food and Agriculture Organization of the United Nations, 2021, Available at: <http://www.fao.org/faostat/en/#data>.
- [149] R. Fernandez, F. Martirena, K. L. Scrivener, "The origin of the pozzolanic activity of calcined clay minerals: A comparison between kaolinite, illite and montmorillonite", *Cement and Concrete Research*, 41(1), 2011, pp. 113–122, doi: 10.1016/j.cemconres.2010.09.013.
- [150] S. Fernando, C. Gunasekara, D. W. Law, M.C.M. Nasvi, S. Setunge, R. Dissanayake, "Life cycle assessment and cost analysis of fly ash–rice husk ash blended alkali-activated concrete", *Journal of Environmental Management*, 295, 2011, #113140, doi: 10.1016/j.jenvman.2021.113140.
- [151] F. Lamers, M. Cremers, D. Matschegg, C. Schmidl, K. Hannam, P. Hazlett, S. Madrali, B. Primdal Dam, R. Roberto, R. Mager, K. Davidsson, N. Bech, H. J. Feuerborn, A. Saraber, "Options for increased use of ash from biomass combustion and co-firing", *IEA Bioenergy*, Deliverable D7, 2018, pp. 1–61.
- [152] M. L. Granizo, M. T. Blanco, "Alkaline Activation Of Metakaolin", *Journal of Thermal Analysis and Calorimetry*, 52, 1998, pp. 957–965.
- [153] T. Hertel and Y. Pontikes, "Geopolymers, inorganic polymers, alkali-activated materials and hybrid binders from bauxite residue (red mud) – Putting things in perspective", *Journal of Cleaner Production*, 258, 2020, #120610, doi: 10.1016/j.jclepro.2020.120610.
- [154] S. Hollanders, R. Adriaens, J. Skibsted, Ö. Cizer, J. Elsen, "Pozzolanic reactivity of pure calcined clays", *Applied Clay Science*, 132–133, 2016, pp. 552–560, doi: 10.1016/j.clay.2016.08.003.

- [155] H. Y. Hu, H. Liu, W. Q. Shen, G. Q. Luo, A. J. Li, Z. L. Lu, H. Yao, "Comparison of CaO's effect on the fate of heavy metals during thermal treatment of two typical types of MSWI fly ashes in China", *Chemosphere*, 93(4), 2013, pp. 590-596, doi: 10.1016/j.chemosphere.2013.05.077.
- [156] G. F. Huseien, M. Ismail, M. M. Tahir, J. Mirza, N. H. A. Khalid b, M. A. Asaad b, A. Abdulameer Husein, N. Nabilah Sarbini, "Synergism between palm oil fuel ash and slag: Production of environmental-friendly alkali activated mortars with enhanced properties", *Construction and Building Materials*, 170, 2018, pp. 235–244, doi: 10.1016/j.conbuildmat.2018.03.031.
- [157] A. Tironi, M. A. Trezza, A. N. Scian, E. F. Irassar, "Kaolinitic calcined clays: Factors affecting its performance as pozzolans", *Construction and Building Materials*, 28, 2012, pp. 276–281, doi: 10.1016/j.conbuildmat.2011.08.064.
- [158] C. Jian-xiong, C. Han-bin, X. Pei, and Z. Lan-fang, "A study on complex alkali-slag environmental concrete", *International Workshop on Sustainable Development and Concrete Technology*, Beijing, China, May 20-21, 2004, pp. 299–307.
- [159] A. M. Kalinkin, S. Kumar, B. I. Gurevich, T. C. Alex, E. V. Kalinkina, V. V. Tyukavkina, V. T. Kalinnikov, R. Kumar, "Geopolymerization behavior of Cu-Ni slag mechanically activated in air and in CO<sub>2</sub> atmosphere", *International Journal of Mineral Processing*, 112, 2012, pp. 101–106, doi: 10.1016/j.minpro.2012.05.001.
- [160] A. Z. Khalifa, Ö. Cizer, Y. Pontikes, A. Heath, P. Patureau, S. A. Bernal, A. T.M. Marsh, "Advances in alkali-activation of clay minerals", *Cement and Concrete Research*, 132, 2020, doi: 10.1016/j.cemconres.2020.106050.
- [161] K. Komnitsas, D. Zaharaki, V. Perdikatsis, "Geopolymerisation of low calcium ferronickel slags", *Journal of Materials Science*, 42(9), 2007, pp. 3073–3082, doi: 10.1007/s10853-006-0529-2.
- [162] K. König, K. Traven, M. Pavlin, V. Ducman, "Evaluation of locally available amorphous waste materials as a source for alternative alkali activators", *Ceramics International*, 47(4), 2021, pp. 4864–4873, doi: 10.1016/j.ceramint.2020.10.059.
- [163] S. Kumar, P. García-Triñanes, A. Teixeira-Pinto, M. Bao, "Development of alkali activated cement from mechanically activated silico-manganese (SiMn) slag", *Cement and Concrete Composites*, 40, 2013, pp. 7-13, doi: 10.1016/j.cemconcomp.2013.03.026.
- [164] J. Liu, L. Hu, L. Tang, J. Ren, "Utilisation of municipal solid waste incinerator (MSWI) fly ash with metakaolin for preparation of alkali-activated cementitious material", *Journal of Hazardous Materials*, 402, 2021, p. 123451, doi: 10.1016/j.jhazmat.2020.123451.
- [165] M. A. Longhi, E. D. Rodríguez, S. A. Bernal, J. L. Provis, A. P. Kirchheim, "Valorisation of a kaolin mining waste for the production of geopolymers", *Journal of Cleaner Production*, 115, 2016, pp. 265–272, doi: 10.1016/j.jclepro.2015.12.011.
- [166] B. Lothenbach, K. Scrivener, R. D. Hooton, "Cement and Concrete Research Supplementary cementitious materials", *Cement and Concrete Research*, 41(12), 2011, pp. 1244–1256, doi: 10.1016/j.cemconres.2010.12.001.
- [167] Y. L. Galiano, C. F. Pereira, J. Vale, "Stabilization/solidification of a municipal solid waste incineration residue using fly ash-based geopolymers", *Journal of Hazardous Materials*, 185(1), 2011, pp. 373–381, doi: 10.1016/j.jhazmat.2010.08.127.
- [168] I. Maragkos, I. P. Giannopoulou and D. Pnias, "Synthesis of ferronickel slag-based geopolymers", *Minerals Engineering*, 22(2), 2009, pp. 196–203, doi: 10.1016/j.mineng.2008.07.003.

- [169] S. A. Miller, A. Horvath, P. J. M. Monteiro, “Readily implementable techniques can cut annual CO<sub>2</sub> emissions from the production of concrete by over 20 %”, *Environmental Research Letters*, 11, 2016, doi: 10.1088/1748-9326/11/7/074029.
- [170] J. Monzó, J. Payá, M. V. Borrachero, I. Girbés, “Reuse of sewage sludge ashes (SSA) in cement mixtures: the effect of SSA on the workability of cement mortars”, *Waste Management*, 23(4), 2003, pp. 373–381, doi: 10.1016/S0956-053X(03)00034-5.
- [171] S. K. Nath, N. S. Randhawa, S. Kumar, “Resources , Conservation & Recycling A review on characteristics of silico-manganese slag and its utilization into construction materials”, *Resources, Conservation & Recycling*, 176(August 2021), 2022, #105946, doi: 10.1016/j.resconrec.2021.105946.
- [172] S. Onisei, Y. Pontikes, T. Van Gerven, G.N. Angelopoulos, T. Velea, V. Predica, P. Moldovan, “Synthesis of inorganic polymers using fly ash and primary lead slag”, *Journal of Hazardous Materials*, 205–206, 2021, pp. 101–110, doi: 10.1016/j.jhazmat.2011.12.039.
- [173] H. Peng, C. Cui, C.S. Cai, Y. Liu, “Synthesis and Reaction Mechanism of an Alkali-Activated Metakaolin-Slag Composite System at Room Temperature”, *Journal of Materials in Civil Engineering*, 31, 2019, #4018345, doi: 10.1061/(ASCE)MT.1943-5533.0002558.
- [174] R. Pouhet, M. Cyr “Formulation and performance of flash metakaolin geopolymer concretes”, *Construction and Building Materials*, 120, 2016, pp. 150–160, doi: 10.1016/j.conbuildmat.2016.05.061.
- [175] R. Pouhet, M. Cyr, R. Bucher, “Influence of the initial water content in flash calcined metakaolin-based geopolymer”, *Construction and Building Materials*, 201, 2019, pp. 421–429, doi: 10.1016/j.conbuildmat.2018.12.201.
- [176] J. L. Provis, R. Hanafi, P. Garcia-Trinanes, “Valorisation of wastes by alkali-activation - progress, opportunities and pitfalls”, in *Slag Valorisation Symposium Zero Waste*, July 2015, Leuven.
- [177] J. L. Provis, “Alkali-activated materials”, *Cement and Concrete Research*, 114, 2018, pp. 40–48, doi: 10.1016/j.cemconres.2017.02.009.
- [178] J. L. Provis, S. A. Bernal, “Geopolymers and related alkali-activated materials”, *Annual Review of Materials Research*, 44, 2014, pp. 299–327, doi: 10.1146/annurev-matsci-070813-113515.
- [179] J. L. Provis, P. Duxson, J. S. J. van Deventer, “The role of particle technology in developing sustainable construction materials”, *Advanced Powder Technology*, 21(1), 2010, pp. 2–7, doi: 10.1016/j.appt.2009.10.006.
- [180] J. L. Provis, A. Palomo, C. Shi, “Advances in understanding alkali-activated materials”, *Cement and Concrete Research*, 2015, pp. 110–125, doi: 10.1016/j.cemconres.2015.04.013.
- [181] A. Rao, K.N. Jha, S. Misra, “Use of aggregates from recycled construction and demolition waste in concrete”, *Resources, Conservation and Recycling*, 50(1), 2007, pp. 71–81, doi: 10.1016/j.resconrec.2006.05.010.
- [182] L. Reig, M. M. Tashima, L. Soriano, M. V. Borrachero, J. Monzó, J. Payá, “Alkaline Activation of Ceramic Waste Materials”, *Waste and Biomass Valorization*, 4(4), 2013, pp. 729–736, doi: 10.1007/s12649-013-9197-z.
- [183] M. A. Salih, N. Farzadnia, A. Abdullah Abang Ali., R. Demirboga, “Development of high strength alkali activated binder using palm oil fuel ash and GGBS at ambient temperature”, *Construction and Building Materials*, 93, 2015, pp. 289–300, doi: 10.1016/j.conbuildmat.2015.05.119.

- [184] M. H. Samarakoon, P. G. Ranjith, W. H. Duan, A. Haque, B. K. Chen, “Extensive use of waste glass in one-part alkali-activated materials: Towards sustainable construction practices”, *Waste Management*, 130, 2021, pp. 1–11, doi: 10.1016/j.wasman.2021.04.060.
- [185] R. San Nicolas, M. Cyr, G. Escadeillas, “Characteristics and applications of flash metakaolins”, *Applied Clay Science*, 83–84, 2013, pp. 253–262, doi: 10.1016/j.clay.2013.08.036.
- [186] C. Shi and J. Qian, “High performance cementing materials from industrial slags — a review”, *Resources, Conservation and Recycling*, 29(3), 2000, pp. 195–207, doi: 10.1016/S0921-3449(99)00060-9.
- [187] R. Siddique, J. Klaus, “Influence of metakaolin on the properties of mortar and concrete: A review”, *Applied Clay Science*, 43(3–4), 2009, pp. 392–400, doi: 10.1016/j.clay.2008.11.007.
- [188] J. Singh, J. and S. P. Singh, “Development of Alkali-activated Cementitious Material using Copper Slag”, *Construction and Building Materials*, 211, 2019, pp. 73–79, doi: 10.1016/j.conbuildmat.2019.03.233.
- [189] C. Jian-xiong, C. Han-bin, X. Pei, Z. Lan-fang “A Study on Complex Alkali-Slag Environmental Concrete”, *Proceedings of Int. Workshop on Sustainable Development and Concrete Technology*, China, 2004, pp. 229-307.
- [190] M. Smol, J. Kulczycka, A. Henclik, K. Gorazda, Z. Wzorek, “The possible use of sewage sludge ash (SSA) in the construction industry as a way towards a circular economy”, *Journal of Cleaner Production*, 95, 2015, pp. 45–54, doi: 10.1016/j.jclepro.2015.02.051.
- [191] H. K. Tchakouté, C. H. Rusher, S. Kong, N. Ranjbar, “Synthesis of sodium waterglass from white rice husk ash as an activator to produce metakaolin-based geopolymer cements”, *Journal of Building Engineering*, 6, 2016, pp. 252–261, doi: 10.1016/j.jobbe.2016.04.007.
- [192] C. E. White, J. L. Provis, T. Proffen, D. P. Riley, J.S.J. van Deventer, “Density functional modeling of the local structure of kaolinite subjected to thermal dihydroxylation”, *Journal of Physical Chemistry A*, 114(14), 2010, pp. 4988–4996, doi: 10.1021/jp9111108d.
- [193] C. E. White, J. L. Provis, T. Proffen, J. S. J. van Deventer, “Molecular Mechanisms Responsible for the Structural Changes Occurring During Geopolymerization: Multiscale Simulation”, *AIChE Journal*, 59(7), 2012, pp. 2241–2253, doi: 10.1002/aic.
- [194] T. Yang, Z. Zhang, H. Zhu, X. Gao, C. Dai, Q. Wu, “Re-examining the suitability of high magnesium nickel slag as precursors for alkali-activated materials”, *Construction and Building Materials*, 213, 2019, pp. 109–120, doi: 10.1016/j.conbuildmat.2019.04.063.
- [195] D. Zaharaki, M. Galetakis, K. Komnitsas, “Valorization of construction and demolition (C&D) and industrial wastes through alkali activation”, *Construction and Building Materials*, 121, 2016, pp. 686–693, doi: 10.1016/j.conbuildmat.2016.06.051.
- [196] L. Zheng, C. Wang, W. Wang, Y. Shi, X. Gao, “Immobilization of MSWI fly ash through geopolymerization: effects of water-wash”, *Waste management*, 31(2), 2011, p. 311–317, doi: 10.1016/j.wasman.2010.05.015.
- [197] P. V. Krivenko, M. Sanytsky, T. Kropyvnytska, “Alkali-sulfate activated blended Portland cements”, *Solid State Phenom*, 276, 2018, pp. 9–14, doi: 10.4028/www.scientific.net/SSP.276.9.
- [198] S. A. Bernal, R. San Nicolas, J. S. J. van Deventer, J. L. Provis, “Alkali-activated slag cements produced with a blended sodium carbonate/sodium silicate activator”, *Adv. Cem. Res*, 28(4), 2016, pp. 262–273, doi: 10.1680/jadcr.15.00013.
- [199] O. A. Mohamed, “A review of durability and strength characteristics of alkali-activated slag concrete”, *Materials*, 12(8), 2019, #1198, doi: 10.3390/ma12081198.

- [200] F. Shaqour, M. Ismeik, M. Esaifan, "Alkali activation of natural clay using a  $\text{Ca}(\text{OH})_2 / \text{Na}_2\text{CO}_3$  alkaline mixture", *Clay Miner*, 52(4), 2017, pp. 485–496, doi: 10.1180/claymin.2017.052.4.06.
- [201] C. Duran Atış, C. Bilim, Ö. Çelik, O. Karahan, "Influence of activator on the strength and drying shrinkage of alkali-activated slag mortar", *Constr. Build. Mater*, 23(1), 2009, pp. 548–555, doi: 10.1016/j.conbuildmat.2007.10.011.
- [202] A. G. Elkhebu, A. Zainorabidin, B. B. K. Huat, "Alkaline Activation of Clayey Soil Using Potassium Hydroxide & Fly Ash", *Int. Journal of Integrated Engineering*, 10(9), 2019, pp. 84–89, doi: 10.30880/ijie.2018.10.09.016.
- [203] A. R. Brough, A. Atkinson, "Sodium silicate-based, alkali-activated slag mortars: Part I. Strength, hydration and microstructure", *Cem. Concr. Res*, 32(6), 2002, pp. 865–879, doi: 10.1016/S0008-8846(02)00717-2.
- [204] H. Ye, A. Radlińska, "Carbonation-induced volume change in alkali-activated slag", *Constr. Build. Mater*, 144, 2017, pp. 635–644, doi: 10.1016/j.conbuildmat.2017.03.238.
- [205] F. Pacheco-Torgal, J. A. Labrincha, C. Leonelli, A. Palomo, P. Chindaprasirt (Editors), *Handbook of Alkali-activated Cements, Mortars and Concretes*, 2015.
- [206] P. Duxson, J. L. Provis, G. C. Lukey, S. W. Mallicoat, W. M. Kriven, J.S.J. van Deventer, "Understanding the Relationship Between Geopolymer Composition Microstructure And Mechanical Properties", *Colloids Surfaces A Physicochem. Eng. Asp*, 269(1-3), 2005, pp. 47–58, doi: 10.1016/j.colsurfa.2005.06.060.
- [207] J. L. Provis, J. S. J. van Deventer, *Geopolymers - Structures, Processing, Properties and Industrial Applications*, 2009, ISBN: 978-1-84569-449-4.
- [208] B. Sun, "Mix design methodology for blast furnace slag and fly ash based alkali activated materials", PhD thesis Ghent University, Faculty of Engineering and Architecture, Ghent, Belgium, 2023.
- [209] M. M. A. Elahi, M. M. Hossain, M. R. Karim, M. F. M. Zain, C. Shearer, "A review on alkali-activated binders: Materials composition and fresh properties of concrete", *Construction and Building Materials*, 260, 2020, #119788, doi: 10.1016/j.conbuildmat.2020.119788.
- [210] M. M. Alonso, S. Gismera, M. T. Blanco, M. Lanzon, F. Puertas, "Alkali-activated mortars: Workability and rheological behaviour", *Construction and Building Materials*, 145, 2017, pp. 576-587, doi: 10.1016/j.conbuildmat.2017.04.020.
- [211] H. Alanazi, J. Hu, Y.-R. Kim, "Effect of slag, silica fume, and metakaolin on properties and performance of alkali-activated fly ash cured at ambient temperature", *Construction and Building Materials*, 197, 2019, pp. 747-756, doi: 10.1016/j.conbuildmat.2018.11.172.
- [212] T. Chareerat, P. Chindaprasirt, V. Sirivatnanon, "Workability and strength of coarse high calcium fly ash geopolymers", *Cem. Concr. Composites*, 29(3), 2007, pp. 224-229, doi: 10.1016/j.cemconcomp.2006.11.002.
- [213] B. Nematollahi, J. Sanjayan, "Effect of different superplasticizers and activator combinations on workability and strength of fly ash based geopolymer", *Materials & Design*, 57, 2014, pp. 667-672, doi: 10.1016/j.matdes.2014.01.064.
- [214] E. D. Rodríguez, S. A. Bernal, J. L. Provis, J. Paya, J. M. Monzo, M. V. Borrachero, "Effect of nanosilica-based activators on the performance of an alkali-activated fly ash binder", *Cement and Concrete Composites*, 35(1), 2013, pp. 1-11, doi: 10.1016/j.cemconcomp.2012.08.025.
- [215] J.W. Phair, J. S. J. van Deventer, "Effect of silicate activator pH on the leaching and material characteristics of waste-based inorganic polymers", *Minerals Engineering*, 14(3), 2001, pp. 289-304, doi: 10.1016/S0892-6875(01)00002-4.



- [216] K. Behfarnia, H. Taghvayi Yazeli, K. Khasraghi, "The Effect of Alkaline Activator on Workability and Compressive Strength of Alkali-Activated Slag Concrete", *AUT Journal of Civil Engineering*, 1(1), 2017, pp. 55-60.
- [217] M. Palacios, F. Puertas, "Effect of superplasticizer and shrinkage-reducing admixtures on alkali-activated slag pastes and mortars", *Cement and Concrete Research*, 35(7), 2005, pp. 1358-1367, doi: 10.1016/j.cemconres.2004.10.014.
- [218] J.G. Jang, N.K. Lee, H.K. Lee, "Fresh and hardened properties of alkali-activated fly ash/slag pastes with superplasticizers", *Construction and Building Materials*, 50, 2014, pp. 169-176, doi: 10.1016/j.conbuildmat.2013.09.048.
- [219] S. Tong, Z. Yuqi, W. Qiang, "Recent advances in chemical admixtures for improving the workability of alkali-activated slag-based material systems", *Construction and Building Materials*, 272, 2021, p. 121647, doi: 10.1016/j.conbuildmat.2020.121647.
- [220] C. Shi, B. Qu, and J.L. Provis, "Recent progress in low-carbon binders", *Cement and Concrete Research*, 122, 2019, pp. 227-250, doi: 10.1016/j.cemconres.2019.05.009.
- [221] G. Vikas, T.G. Rao, "Setting Time, Workability and Strength Properties of Alkali Activated Fly Ash and Slag Based Geopolymer Concrete Activated with High Silica Modulus Water Glass", *Iranian Journal of Science and Technology, Transactions of Civil Engineering*, 2021, pp. 1-10.
- [222] G. F. Huseien, J. Mirza, M. Ismail, S. K. Ghoshal, M. A. M. Ariffin, "Effect of metakaolin replaced granulated blast furnace slag on fresh and early strength properties of geopolymer mortar", *Ain Shams Engineering Journal*, 9(4), 2018, pp. 1557-1566, doi: 10.1016/j.asej.2016.11.011.
- [223] K. Wianglor, S. Sinthupinyo, M. Piyaworapaibon, A. Chaipanich, "Effect of alkali-activated metakaolin cement on compressive strength of mortars", *Applied Clay Science*, 141, 2017, pp. 272-279, doi: 10.1016/j.clay.2017.01.025.
- [224] E. Badogiannis, G. Kakali, G. Dimopoulou, E. Chaniotakis, S. Tsvilis, "Metakaolin as a main cement constituent. Exploitation of poor Greek kaolins", *Cement and Concrete Composites*, 27(2), 2005, pp. 197-203, doi: 10.1016/j.cemconcomp.2004.02.007.
- [225] G. Görhan, R. Aslaner, O. Şinik, "The effect of curing on the properties of metakaolin and fly ash-based geopolymer paste", *Composites Part B: Engineering*, 97, 2016, pp. 329-335, doi: 10.1016/j.compositesb.2016.05.019.
- [226] P. S. Deb, P. K. Sarker, "Effects of ultrafine fly ash on setting, strength, and porosity of geopolymers cured at room temperature", *Journal of Materials in Civil Engineering*, 29(2), 2017, p. 06016021, doi: 10.1061/(ASCE)MT.1943-5533.0001745.
- [227] D. Adak, M. Sarkar, S. Mandal, "Effect of nano-silica on strength and durability of fly ash based geopolymer mortar", *Construction and Building Materials*, 70, 2014, pp. 453-459, doi: 10.1016/j.conbuildmat.2014.07.093.
- [228] H. Y. Zhang, V. Kodur, B. Wu, L. Cao, F. Wang, "Thermal behavior and mechanical properties of geopolymer mortar after exposure to elevated temperatures", *Construction and Building Materials*, 109, 2016, pp. 17-24, doi: 10.1016/j.conbuildmat.2016.01.043.
- [229] B. H. Tekle, L. Hertwig, K. Holschemacher, "Setting Time and Strength Monitoring of Alkali-Activated Cement Mixtures by Ultrasonic Testing", *Materials*, 14(8), 2021, pp. 1889, doi: 10.3390/ma14081889.
- [230] S. Musaddiq Laskar, S. Talukdar, "Development of ultrafine slag-based geopolymer mortar for use as repairing mortar", *Journal of Materials in Civil Engineering*, 29(5), 2017, #04016292, doi: 10.1061/(ASCE)MT.1943-5533.0001824.
- [231] V. K. Nagaraj, D. L. Venkatesh Babu, "Assessing the performance of molarity and alkaline activator ratio on engineering properties of self-compacting alkaline activated concrete at



- ambient temperature”, *Journal of Building Engineering*, 20, 2018, pp. 137-155, doi: 10.1016/j.jobbe.2018.07.005.
- [232] A. Fernández-Jiménez, F. Puertas, “Effect of activator mix on the hydration and strength behaviour of alkali-activated slag cements”, *Advances in cement research*, 15(3), 2003, pp. 129-136, doi: 10.1680/adcr.2003.15.3.129.
- [233] N. Li, N., C. Shi, Z. Zhang, “Understanding the roles of activators towards setting and hardening control of alkali-activated slag cement”, *Composites Part B: Engineering*, 171, 2019, pp. 34-45, doi: 10.1016/j.compositesb.2019.04.024.
- [234] W. Song, Z. Zhu, Y. Peng, Y. Wan, X. Xu, S. Pu, S. Song, Y. Wei, “Effect of steel slag on fresh, hardened and microstructural properties of high-calcium fly ash based geopolymers at standard curing condition”, *Construction and Building Materials*, 229, 2019, doi: 10.1016/j.conbuildmat.2019.116933.
- [235] W. Song, Z. Zhu, S. Pu, Y. Wan, W. Huo, S. Song, J. Zhang, K. Yao, L. Hu, “Efficient use of steel slag in alkali-activated fly ash-steel slag-ground granulated blast furnace slag ternary blends”, *Construction and Building Materials*, 259, 2020, p. 119814, doi: 10.1016/j.conbuildmat.2020.119814.
- [236] P. Chindaprasirt, T. Chareerat, S. Hatanaka, T. Cao, “High-strength geopolymer using fine high-calcium fly ash”, *Journal of materials in civil engineering*, 23(3), 2011, pp. 264–270: doi: 10.1061/(ASCE)MT.1943-5533.0000161.
- [237] P. S. Deb, P. K. Sarker, S. Barbhuiya, “Sorptivity and acid resistance of ambient cured geopolymer mortars containing nano-silica”, *Cement and Concrete Composites*, 72, 2016, pp. 235–245, doi: 10.1016/j.cemconcomp.2016.06.017.
- [238] N. Ranjbar, M. Mehrali, U.J. Alengaram, H.S.C. Metselaar, M.Z. Jumaat, “Compressive strength and microstructural analysis of fly ash/palm oil fuel ash based geopolymer mortar under elevated temperatures”, *Construction and Building Materials*, 65, 2014, pp. 114–121, doi: 10.1016/j.matdes.2014.03.037.
- [239] M. Ariffin, M. Azreen, M. W. Hussin, M. A. Rafique Bhutta, “Mix design and compressive strength of geopolymer concrete containing blended ash from agro-industrial wastes”, *Advanced Materials Research*, 339, 2011, pp. 452–457, doi: 10.4028/www.scientific.net/AMR.339.452.
- [240] B. Zhang, H. Zhu, K. Wei Shah, P. Feng, Z. Dong, “Optimization of mix proportion of alkali-activated slag mortars prepared with seawater and coral sand”, *Construction and Building Materials*, 284, 2021, #122805, doi: 10.1016/j.conbuildmat.2021.122805.
- [241] G. F. Huseien, A. R. M. Sam, K. W. Shah, M. A. Asaad, M. M. Tahir, J. Mirza, “Properties of ceramic tile waste based alkali-activated mortars incorporating GBFS and fly ash”, *Construction and Building Materials*, 214, 2019, pp. 355–368, doi: 10.1016/j.conbuildmat.2019.04.154.
- [242] Z. Tang, Y. Hu, W. Li, V. W.Y. Tam, “Uniaxial compressive behaviors of fly ash/slag-based geopolymeric concrete with recycled aggregates”, *Cement and Concrete Composites*, 104, 2019, #103375, doi: 10.1016/j.cemconcomp.2019.103375.
- [243] J. Xie, J. Wang, R. Rao, C. Wang, C. Fang, “Effects of combined usage of GGBS and fly ash on workability and mechanical properties of alkali activated geopolymer concrete with recycled aggregate”, *Composite part B : Engineering*, 164, 2019, pp. 179-190, doi: 10.1016/j.compositesb.2018.11.067.
- [244] B. Sun, G. Ye, G. de Schutter, “A review: Reaction mechanism and strength of slag and fly ash-based alkali-activated materials”, *Construction and Building Materials*, 326, 2022, p. 126843, doi: 10.1016/j.conbuildmat.2022.126843.

- [245] M. Cyr, R. Pouhet, "Resistance to alkali-aggregate reaction (AAR) of alkali-activated cement-based binders", *Handbook of Alkali-Activated Cements, Mortars and Concretes*, Woodhead Publishing Limited, 2015, pp. 397-422, doi: 10.1533/9781782422884.3.397.
- [246] K. Arbi, M. Nedeljkovic, Y. Zuo, G. Ye, "A review on durability of alkali activated fly ash/slag systems: Advances, issues and perspectives", *Industrial & Engineering Chemistry Research*, 55(19), 2016, pp. 5439-5453, doi: 10.1021/acs.iecr.6b00559.
- [247] Z. Zhang, C. Shi, Z. Zhang, Z. Ou, "Durability of alkali-activated materials in aggressive environments: A review on recent studies", *Construction and Building Materials*, 152, 2017, pp. 598-613, doi: 10.1016/j.conbuildmat.2017.07.027.
- [248] M. Mastali, P. Kinnunen, A. Dalvand, R. M. Firouz, M. Illikainen, "Drying shrinkage in alkali-activated binders—a critical review", *Construction and Building Materials*, 190, 2018, pp. 533-550, doi: 10.1016/j.conbuildmat.2018.09.125.
- [249] M. F. Bertos, S. J. R. Simons, C. D. Hills, P. J. Carey, "A review of accelerated carbonation technology in the treatment of cement-based materials and sequestration of CO<sub>2</sub>", *Journal of hazardous materials*, 112(3), 2004, pp. 193-205, doi: 10.1016/j.jhazmat.2004.04.019.
- [250] D. W. Hobbs, "Concrete deterioration: causes, diagnosis, and minimising risk", *International Materials Reviews*, 46(3), 2001, pp. 117-144, doi: 10.1179/095066001101528420.
- [251] M. Palacios, F. Puertas, "Effect of carbonation on alkali-activated slag paste", *Journal of the American Ceramic Society*, 89(10), 2006, pp. 3211-3221, doi: 10.1111/j.1551-2916.2006.01214.x.
- [252] F. Puertas, M. Palacios, T. Vázquez, "Carbonation process of alkali-activated slag mortars", *Journal of materials science*, 41(10), 2006, pp. 3071-3082, doi: 10.1007/s10853-005-1821-2
- [253] T. Bakharev, J. Sanjayan, Y. B. Cheng, "Resistance of alkali-activated slag concrete to carbonation", *Cement and Concrete Research*, 31(9), 2001, pp. 1277-1283, doi: 10.1016/S0008-8846(01)00574-9.
- [254] S. A. Bernal, R. San Nicolas, R. J. Myers, R. M. de Gutierrez, F. Puertas, J. S. J. van Deventer, J. L. Provis, "MgO content of slag controls phase evolution and structural changes induced by accelerated carbonation in alkali-activated binders", *Cement and Concrete Research*, 57, 2014, pp. 33-43, doi: 10.1016/j.cemconres.2013.12.003.
- [255] S. A. Bernal, R. M. de Gutierrez, A. L. Pedraza, J. L. Provis, E. D. Rodriguez, S. Delvasto, "Effect of binder content on the performance of alkali-activated slag concretes", *Cement and concrete research*, 41(1), 2011, pp. 1-8, doi: 10.1016/j.cemconres.2010.08.017.
- [256] M. Nedeljković, B. Ghiassi, S. van der Laan, Z. Li, G. Ye, "Effect of curing conditions on the pore solution and carbonation resistance of alkali-activated fly ash and slag pastes", *Cement and Concrete Research*, 116, 2019, pp. 146-158, doi: 10.1016/j.cemconres.2018.11.011.
- [257] S. A. Bernal, R. M. de Gutierrez, J. L. Provis, V. Rose, "Effect of silicate modulus and metakaolin incorporation on the carbonation of alkali silicate-activated slags", *Cement and Concrete Research*, 40(6), 2010, pp. 898-907, doi: 10.1016/j.cemconres.2010.02.003.
- [258] Z. Shi, C. Shi, S. Wan, N. Li, Z. Zhang, "Effect of alkali dosage and silicate modulus on carbonation of alkali-activated slag mortars", *Cement and Concrete Research*, 113, 2018, pp. 55-64, doi: 10.1016/j.cemconres.2018.07.005.
- [259] S. A. Bernal, J. L. Provis, D. G. Brice, A. Kilcullen, P. Duxson, J. S. J. van Deventer, "Accelerated carbonation testing of alkali-activated binders significantly underestimates service life: The role of pore solution chemistry", *Cement and Concrete Research*, 42(10), 2012, pp. 1317-1326, doi: 10.1016/j.cemconres.2012.07.002.

- [260] S. A Bernal, J. L. Provis, “Durability of alkali-activated materials: progress and perspectives”, *Journal of the American Ceramic Society*, 97(4), 2014, pp. 997-1008, doi: 10.1111/jace.12831.
- [261] A. M. Neville, *Properties of concrete*, Longman London, 1995, ISBN 9780273755807.
- [262] H. F. Taylor, *Cement chemistry*, Thomas Telford London, 1997, ISBN: 9780727725929.
- [263] P. K. Mehta, “Mechanism of sulfate attack on portland cement concrete—Another look”, *Cement and Concrete Research*, 13(3), 1983, pp. 401-406, doi: 10.1016/0008-8846(83)90040-6.
- [264] J. Bai, “Durability of sustainable concrete materials”, in *Sustainability of Construction Materials*, J.M. Khatib, Editor, Woodhead Publishing, 2009, pp. 239-253.
- [265] I. Ismail, S. A. Bernal, J. L. Provis, S. Hamdan, J. S. J. van Deventer, “Microstructural changes in alkali activated fly ash/slag geopolymers with sulfate exposure”, *Materials and structures*, 46(3), 2013, pp. 361-373, doi: 10.1617/s11527-012-9906-2.
- [266] M. Komljenović, et al., “External sulfate attack on alkali-activated slag”, *Construction and Building Materials*, 49, 2013, pp. 31-39, doi: 10.1016/j.conbuildmat.2013.08.013.
- [267] T. Bakharev, J. G. Sanjayan, Y. B. Cheng, “Sulfate attack on alkali-activated slag concrete”, *Cement and Concrete research*, 32(2), 2002, pp. 211-216, doi: 10.1016/S0008-8846(01)00659-7.
- [268] B. Mithun, M. Narasimhan, “Performance of alkali activated slag concrete mixes incorporating copper slag as fine aggregate”, *Journal of Cleaner Production*, 112, 2016, pp. 837-844, doi: 10.1016/j.jclepro.2015.06.026.
- [269] W. C. Wang, H. Y. Wang, M. H. Lo, “The fresh and engineering properties of alkali activated slag as a function of fly ash replacement and alkali concentration”, *Construction and Building Materials*, 84, 2015, pp. 224-229, doi: 10.1016/j.conbuildmat.2014.09.059.
- [270] F. Puertas, R. Mejia, A. Fernández-Jiménez, S. Delvasto, “Alkaline cement mortars. Chemical resistance to sulfate and seawater attack”, *Materiales de Construcción*, 52(267), 2002, pp. 55-71.
- [271] A. Fernández-Jiménez, I. Garcia-Lodeiro, A. Palomo, “Durability of alkali-activated fly ash cementitious materials”, *Journal of Materials Science*, 42(9), 2007, pp. 3055-3065, doi: 10.1007/s10853-006-0584-8.
- [272] D. Hardjito, S. E. Wallah, D. M. J. Sumajouw, B. V. Rangan, “On the development of fly ash-based geopolymer concrete”, *Materials Journal*, 101(6), 2004, pp. 467-472, doi: 10.14359/13485.
- [273] F. Slaty, H. Houry, H. Rahier, J. Wastiels, “Durability of alkali activated cement produced from kaolinitic clay”, *Applied Clay Science*, 104, 2015, pp. 229-237, doi: 10.1016/j.clay.2014.11.037.
- [274] M. Hu, X. Zhu, F. Long, “Alkali-activated fly ash-based geopolymers with zeolite or bentonite as additives”, *Cement and Concrete Composites*, 31(10), 2009, pp. 762-768, doi: 10.1016/j.cemconcomp.2009.07.006.
- [275] T. Bakharev, “Durability of geopolymer materials in sodium and magnesium sulfate solutions”, *Cement and concrete research*, 35(6), 2005, pp. 1233-1246, doi: 10.1016/j.cemconres.2004.09.002.
- [276] T. Lingyu, H. Dongpo, Z. Jianing, W. Hongguang, “Durability of geopolymers and geopolymer concretes: A review”, *Reviews on Advanced Materials Science*, 60(1), 2021, pp. 1-14, doi: 10.1515/rams-2021-0002.

- [277] V. Bilek, O. Sucharda, D. Bujdos, “Frost Resistance of Alkali-Activated Concrete—An Important Pillar of Their Sustainability”, *Sustainability*, 13(2), 2021, p. 473, doi: 10.3390/su13020473.
- [278] F. Škvára, T. Jílek, L. Kopecký, “Geopolymer materials based on fly ash”, *Ceram.-Silik*, 49(3), 2005, pp. 195-204, Available at: [https://www.irsm.cas.cz/materialy/cs\\_content/2005/Skvara\\_CS\\_2005\\_0000.pdf](https://www.irsm.cas.cz/materialy/cs_content/2005/Skvara_CS_2005_0000.pdf).
- [279] P. Sun, H. C. Wu, “Chemical and freeze–thaw resistance of fly ash-based inorganic mortars”, *Fuel*, 111, 2013, pp. 740-745, doi: 0.1016/j.fuel.2013.04.070.
- [280] H. Shu, “A Preliminary Research on Alkali-activated slag concrete as Tunnel Lining in Severe Frigid Regions”, *Advanced Materials Research*, 668, 2013, pp. 65-69, doi: 10.4028/www.scientific.net/AMR.668.65.
- [281] F. Winnefeld, G. J. G. Gluth, S. A. Bernal, et al., “RILEM TC 247-DTA round robin test: sulfate resistance, alkali-silica reaction and freeze–thaw resistance of alkali-activated concretes”, *Materials and Structures*, 53(6), 2020, #140, doi: 10.1617/s11527-020-01562-0.
- [282] M. Cyr, R. Pouhet, “The frost resistance of alkali-activated cement-based binders”, *Handbook of Alkali-Activated Cements, Mortars and Concretes*, Woodhead Publishing, 2015, pp. 293-318, doi: 10.1533/9781782422884.3.293.
- [283] F. Puertas, T. Amat, A. Fernández-Jiménez, T. Vázquez, “Mechanical and durable behaviour of alkaline cement mortars reinforced with polypropylene fibres”, *Cement and concrete research*, 33(12), 2003, pp. 2031-2036, doi: 10.1016/S0008-8846(03)00222-9.
- [284] B. Chen, J. Wang, “Experimental Study on the Durability of Alkali-Activated Slag Concrete after Freeze-Thaw Cycle”, *Advances in Materials Science and Engineering*, 2021, #9915639, doi: 10.1155/2021/9915639.
- [285] L. Cai, H. Wang, Y. Fu, “Freeze–thaw resistance of alkali–slag concrete based on response surface methodology”, *Construction and Building Materials*, 49, 2013, pp. 70-76, doi: 10.1016/j.conbuildmat.2013.07.045.
- [286] M. Najimi, “Alkali-activated natural pozzolan/slag binder for sustainable concrete”, PhD thesis University of Nevada , Las Vegas, 2016.
- [287] S. Pilehvar, A. M. Szczotok, J. Francisco Rodríguez, L. Valentini, M. Lanzón, R. Pamies, A.-L. Kjøniksen, “Effect of freeze-thaw cycles on the mechanical behavior of geopolymer concrete and Portland cement concrete containing micro-encapsulated phase change materials”, *Construction and Building Materials*, 200, 2019, pp. 94-103, doi: 10.1016/j.conbuildmat.2018.12.057.
- [288] R. R. Lloyd, J. L. Provis, J. S. J. van Deventer, “Pore solution composition and alkali diffusion in inorganic polymer cement”, *Cement and Concrete Research*, 40(9), 2010, pp. 1386-1392, doi: 10.1016/j.cemconres.2010.04.008.
- [289] H. Zhu, Z. Zhang, Y. Zhu, L. Tian, “Durability of alkali-activated fly ash concrete: Chloride penetration in pastes and mortars”, *Construction and Building Materials*, 65, 2014, pp. 51-59, doi: 10.1016/j.conbuildmat.2014.04.110.
- [290] T. Yang, X. Yao, Z. Zhang, “Quantification of chloride diffusion in fly ash–slag-based geopolymers by X-ray fluorescence (XRF)”, *Construction and building materials*, 69, 2014, pp. 109-115, doi: 10.1016/j.conbuildmat.2014.07.031.
- [291] D. Ravikumar, N. Neithalath, “An electrical impedance investigation into the chloride ion transport resistance of alkali silicate powder activated slag concretes”, *Cement and Concrete Composites*, 44, 2013, pp. 58-68, doi: 10.1016/j.cemconcomp.2013.06.002.

- [292] K. Kupwade-Patil, E. N. Allouche, "Examination of chloride-induced corrosion in reinforced geopolymer concretes", *Journal of Materials in Civil Engineering*, 25(10), 2013, pp. 1465-1476, doi: 10.1061/(ASCE)MT.1943-5533.0000672.
- [293] I. Ismail, S. A. Bernal, J. L. Provis, et al., "Influence of fly ash on the water and chloride permeability of alkali-activated slag mortars and concretes", *Construction and Building Materials*, 48, 2013, pp. 1187-1201, doi: 10.1016/j.conbuildmat.2013.07.106.
- [294] D. Ravikumar, N. Neithalath, "Electrically induced chloride ion transport in alkali activated slag concretes and the influence of microstructure", *Cement and Concrete Research*, 47, 2013, pp. 31-42, doi: 10.1016/j.cemconres.2013.01.007.
- [295] P. Chindaprasirt, W. Chalee, "Effect of sodium hydroxide concentration on chloride penetration and steel corrosion of fly ash-based geopolymer concrete under marine site", *Construction and Building Materials*, 63, 2014, pp. 303-310, doi: 10.1016/j.conbuildmat.2014.04.010.
- [296] Y. Ma, J. Hu, G. Ye, "The pore structure and permeability of alkali activated fly ash", *Fuel*, 104, 2013, pp. 771-780, doi: 10.1016/j.fuel.2012.05.034.
- [297] Q. Ma, S. V. Nanukuttan, P. A. M. Basheer, Y. Bai, C. Yang, "Chloride transport and the resulting corrosion of steel bars in alkali activated slag concretes", *Materials and Structures*, 49(9), 2016, pp. 3663-3677, doi: 10.1617/s11527-015-0747-7.
- [298] X. Ke, S. A. Bernal, O. H. Hussein, J. L. Provis, "Chloride binding and mobility in sodium carbonate-activated slag pastes and mortars", *Materials and Structures*, 50(6), 2017, p. 252, doi: 10.1617/s11527-017-1121-8.
- [299] F. Collins, J. G. Sanjayan, "Effect of pore size distribution on drying shrinking of alkali-activated slag concrete", *Cement and Concrete Research*, 30(9), 2000, pp. 1401-1406, doi: 10.1016/S0008-8846(00)00327-6.
- [300] Y. Cai, L. Yu, Y. Yang, Y. Gao, C. Yang, "Effect of Early Age-Curing Methods on Drying Shrinkage of Alkali-Activated Slag Concrete", *Materials*, 12(10), 2019, pp. 1633, doi: 10.3390/ma12101633.
- [301] S. Aydın, B. Baradan, "Mechanical and microstructural properties of heat cured alkali-activated slag mortars", *Materials & Design*, 35, 2012, pp. 374-383, doi: 10.1016/j.matdes.2011.10.005.
- [302] A. M. Humad, A. Kothari, J. L. Provis, A. Cwirzen, "The Effect of Blast Furnace Slag/Fly Ash Ratio on Setting, Strength, and Shrinkage of Alkali-Activated Pastes and Concretes" *Frontiers in Materials*, 6(9), 2019, doi: 10.3389/fmats.2019.00009.
- [303] H. Ye, C. Cartwright, F. Rajabipour, A. Radlinska, "Effect of drying rate on shrinkage of alkali-activated slag cements", 4th International Conference on the Durability of Concrete Structures, 24-26 July 2014, Purdue University.
- [304] D. Krizan, B. Zivanovic, "Effects of dosage and modulus of water glass on early hydration of alkali-slag cements", *Cement and Concrete Research*, 32(8), 2002, pp. 1181-1188, doi: 10.1016/S0008-8846(01)00717-7.
- [305] A. M. Fernandez-Jimenez, A. Palomo, C. Lopez-Hombrados, "Engineering properties of alkali-activated fly ash concrete" *ACI Materials Journal*, 103(2), 2006, pp. 106-112, doi: 10.14359/15261.
- [306] Y. Ma, G. Ye, "The shrinkage of alkali activated fly ash", *Cement and Concrete Research*, 68, 2015, pp. 75-82, doi: 10.1016/j.cemconres.2014.10.024.
- [307] P. S. Deb, P. Nath, P. K. Sarker, "Drying Shrinkage of Slag Blended Fly Ash Geopolymer Concrete Cured at Room Temperature", *Procedia Engineering*, 125, 2015, pp. 594-600, doi: 10.1016/j.proeng.2015.11.066.



- [308] A. M. Rashad, "Properties of alkali-activated fly ash concrete blended with slag", *Iranian Journal of Materials Science and Engineering*, 10(1), 2013, pp. 57-64.
- [309] W. Shen, Y. Wang, T. Zhang, M. Zhou, J. Li, X. Cui, "Magnesia modification of alkali-activated slag fly ash cement", *Journal of Wuhan University of Technology-Mater. Sci. Ed.*, 26(1), 2011, pp. 121-125, doi: 10.1007/s11595-011-0182-8.
- [310] I. Ismail, S. A. Bernal, J. L. Provis, S. Hamdan, J.S.J. van Deventer, "Drying-induced changes in the structure of alkali-activated pastes", *Journal of Materials Science*, 48(9), 2013, pp. 3566-3577, doi: 10.1007/s10853-013-7152-9.
- [311] N. K. Lee, H. K. Lee, "Setting and mechanical properties of alkali-activated fly ash/slag concrete manufactured at room temperature", *Construction and Building Materials*, 47, 2013, pp. 1201-1209, doi: 10.1016/j.conbuildmat.2013.05.10.
- [312] N. K. Lee, J. G. Jang, H. K. Lee, "Shrinkage characteristics of alkali-activated fly ash/slag paste and mortar at early ages", *Cement and Concrete Composites*, 53, 2014, pp. 239-248, doi: 10.1016/j.cemconcomp.2014.07.007.
- [313] T. Yang, H. Zhu, Z. Zhang, "Influence of fly ash on the pore structure and shrinkage characteristics of metakaolin-based geopolymer pastes and mortars", *Construction and Building Materials*, 153, 2017, pp. 284-293, doi: 10.1016/j.conbuildmat.2017.05.067.
- [314] G. Samson, M. Cyr, X. X. Gao, "Formulation and characterization of blended alkali-activated materials based on flash-calcined metakaolin, fly ash and GGBS", *Construction and Building Materials*, 144, 2017, pp. 50-64, doi: 10.1016/j.conbuildmat.2017.03.160.
- [315] C. Kuenzel, L. J. Vandeperre, S. Donatello, A. R. Boccaccini, C. Cheeseman, "Ambient temperature drying shrinkage and cracking in metakaolin-based geopolymers", *Journal of the American Ceramic Society*, 95(10), 2012, pp. 3270-3277, doi: 10.1111/j.1551-2916.2012.05380.x.
- [316] X. Gao, Q. L. Yu, H. J. H. Brouwers, "Assessing the porosity and shrinkage of alkali activated slag-fly ash composites designed applying a packing model", *Construction and Building Materials*, 119, 2016, pp. 175-184, doi: 10.1016/j.conbuildmat.2016.05.026.
- [317] A. A. M. Neto, M. A. Cincotto, W. Repette, "Drying and autogenous shrinkage of pastes and mortars with activated slag cement" *Cement and Concrete Research*, 38(4), 2008, pp. 565-574, doi: 10.1016/j.cemconres.2007.11.002.
- [318] H. Taghvayi, K. Behfarnia, M. Khalili, "The effect of alkali concentration and sodium silicate modulus on the properties of alkali-activated slag concrete", *Journal of Advanced Concrete Technology*, 16(7), 2018, pp. 293-305, doi: 10.3151/jact.16.293.
- [319] R.J. Thomas, D. Lezama, S. Peethamparan, "On drying shrinkage in alkali-activated concrete: Improving dimensional stability by aging or heat-curing" *Cement and Concrete Research*, 91, 2017, pp. 13-23, doi: 10.1016/j.cemconres.2016.10.003.
- [320] S. Hanjitsuwan, S. Hunpratub, P. Thongbai, S. Maensiri, V. Sata, P. Chindapasirt., "Effects of NaOH concentrations on physical and electrical properties of high calcium fly ash geopolymer paste", *Cement and Concrete Composites*, 45, 2014, pp. 9-14, doi: 10.1016/j.cemconcomp.2013.09.012.
- [321] M. Chi, "Effects of modulus ratio and dosage of alkali-activated solution on the properties and micro-structural characteristics of alkali-activated fly ash mortars", *Construction and Building Materials*, 99, 2015, pp. 128-136, doi: 10.1016/j.conbuildmat.2015.09.029.
- [322] M. Kheradmand, Z. Abdollahnejad, F. Pacheco-Torgal, "Shrinkage performance of fly ash alkali-activated cement based binder mortars", *KSCE Journal of Civil Engineering*, 22(5), 2018 pp. 1854-1864, doi: 10.1007/s12205-017-1714-3.



- [323] N. Ranjbar, S. Talebian, M. Mehrali, C. Kuenzel, H. S. C. Metselaar, M. Z. Jumaat, "Mechanisms of interfacial bond in steel and polypropylene fiber reinforced geopolymer composites", *Composites Science and Technology*, 122, 2016, pp. 73-81, doi: 10.1016/j.compscitech.2015.11.009.
- [324] M. Mastali, P. Kinnunen, H. Isomoisio, M. Karhu, M. Illikainen, "Mechanical and acoustic properties of fiber-reinforced alkali-activated slag foam concretes containing lightweight structural aggregates", *Construction and Building Materials*, 187, 2018, pp. 371-381, doi: 10.1016/j.conbuildmat.2018.07.228.
- [325] M. Mastali, A. Dalvand, A.R. Sattarifard, Z. Abdollahnejad, M. Illikainen, "Characterization and optimization of hardened properties of self-consolidating concrete incorporating recycled steel, industrial steel, polypropylene and hybrid fibers", *Composites Part B: Engineering*, 151, 2018, pp. 186-200, doi: 10.1016/j.compositesb.2018.06.021.
- [326] Z. Abdollahnejad, M. Mastali, A. Dalvand, "Comparative study on the effects of recycled glass-fiber on drying shrinkage rate and mechanical properties of the self-compacting mortar and fly ash-slag geopolymer mortar", *Journal of Materials in Civil Engineering*, 29(8), 2017, pp. 04017076, doi: 10.1061/(ASCE)MT.1943-5533.0001918.
- [327] X. Gao, Q. L. Yu, R. Yu, H. J. H. Brouwers, "Evaluation of hybrid steel fiber reinforcement in high performance geopolymer composites", *Materials and Structures*, 50(2), 2017, pp. 1-14, doi: 10.1617/s11527-017-1030-x.
- [328] Z. J. Zhang, G. Z. Dai, S. N. Wu, L. X. Dong, L. L. Liu, "Simulation of 42CrMo steel billet upsetting and its defects analyses during forming process based on the software DEFORM-3D", *Materials Science and Engineering: A*, 499(1-2), 2009, pp. 49-52, doi: 10.1016/j.msea.2007.11.135.
- [329] L. Y. Yang, Z. J. Jia, Y. M. Zhang, J. G. Dai., "Effects of nano-TiO<sub>2</sub> on strength, shrinkage and microstructure of alkali activated slag pastes", *Cement and Concrete Composites*, 57, 2015, pp. 1-7, doi: 10.1016/j.cemconcomp.2014.11.009.
- [330] M. Palacios, F. Puertas, "Effect of shrinkage-reducing admixtures on the properties of alkali-activated slag mortars and pastes", *Cement and Concrete Research*, 37(5), 2007, pp. 691-702, doi: 10.1016/j.cemconres.2006.11.021.
- [331] Y. H. Fang, Y. M. Gu, Q. B. Kang, "Effect of fly ash, MgO and curing solution on the chemical shrinkage of alkali-activated slag cement", . in *Advanced Materials Research*, 168-170, 2011, pp. 2008-2012, doi: 10.4028/www.scientific.net/AMR.168-170.2008.
- [332] F. Jin, K. Gu, A. Al-Tabbaa, "Strength and hydration properties of reactive MgO-activated ground granulated blastfurnace slag paste", *Cement and Concrete Composites*, 57, 2015, pp. 8-16, doi: 10.1016/j.cemconcomp.2014.10.007.
- [333] Z. Jia, Y. Yang, L. Yang, Y. Zhang, Z. Sun, "Hydration products, internal relative humidity and drying shrinkage of alkali activated slag mortar with expansion agents", *Construction and Building Materials*, 158, 2018, pp. 198-207, doi: 10.1016/j.conbuildmat.2017.09.162.
- [334] P. Duan, C. Yan, W. Luo, W. Zhou, "Effects of adding nano-TiO<sub>2</sub> on compressive strength, drying shrinkage, carbonation and microstructure of fluidized bed fly ash based geopolymer paste", *Construction and Building Materials*, 106, 2016, pp. 115-125, doi: 10.1016/j.conbuildmat.2015.12.095.
- [335] T. Bakharev, J. G. Sanjayan, Y. B. Cheng, "Effect of elevated temperature curing on properties of alkali-activated slag concrete", *Cement and Concrete Research*, 29(10), 1999, pp. 1619-1625, doi: 10.1016/S0008-8846(99)00143-X.

- [336] A. Mobili., A. Belli, C. Giosue, T. Bellezze, F. Tittarelli., "Metakaolin and fly ash alkali-activated mortars compared with cementitious mortars at the same strength class", *Cement and Concrete Research*, 88, 2016, pp. 198-210, doi: 10.1016/j.cemconres.2016.07.004
- [337] S. Al-Otaibi, "Durability of concrete incorporating GGBS activated by water-glass", 22(10), 2008, pp. 2059-2067, doi: 10.1016/j.conbuildmat.2007.07.023.
- [338] J. Metso, "The alkali reaction of alkali-activated Finnish blast furnace slag", *Silicates industriels*, 4-5, 123-127, 1982.
- [339] T. Bakharev, J. G. Sanjayan, Y. B. Cheng, "Resistance of alkali-activated slag concrete to alkali-aggregate reaction", *Cement and Concrete Research*, 31(2), 2001, pp. 331-334, doi: 10.1016/S0008-8846(00)00483-X.
- [340] A. Fernández-Jiménez, I. García-Lodeiro, A. Palomo, "Durability of alkali-activated fly ash cementitious materials", *Journal of Materials Science*, 42, 2007, pp. 3055-3065, doi: 10.1007/s10853-006-0584-8.
- [341] K. L. Li, G. H. Huang, J. Chen, D. Wang, X. T. Nanjing, H. T. Co, "Early mechanical property and durability of geopolymer", in Davidovits J (ed.) *Geopolymer: Green Chemistry and Sustainable Development Solutions*, Institut Géopolymère, Saint-Quentin, 117-120, 2005.
- [342] K. L. Li, G. Huang, L. H. Jiang, Y. B. Cai, J. Chen, J. T. Ding, "Study on abilities of mineral admixtures and geopolymer to restrain ASR", *Key Engineering Materials*, 302-303, 2006, pp. 248-254, doi: 10.4028/www.scientific.net/KEM.302-303.248.
- [343] <https://eurocodes.jrc.ec.europa.eu/showpage.php?id=13>.
- [344] A. Adesina, "Performance of fibre reinforced alkali-activated composites - A review," *Materialia*, 12, 2020, doi: 10.1016/j.mtla.2020.100782.
- [345] M. Amran, R. Fediuk, H. S. Abdelgader, G. Murali, T. Ozbakkaloglu, Y.H. Lee, Y.Y. Lee, "Fiber-reinforced alkali-activated concrete: A review", *Journal of Building Engineering*, 45, 2022, # 103638, doi: 10.1016/j.jobe.2021.103638.
- [346] M. di Prisco, M. Colombo, D. Dozio, "Fibre-reinforced concrete in fib Model Code 2010: principles, models and test validation", *Structural concrete*, 14(4), 2013, pp. 342-361, doi: 10.1002/suco.201300021.
- [347] I. Löfgren, "Fibre-reinforced concrete for industrial construction - A fracture mechanics approach to material testing and structural analysis", PhD thesis Chalmers University of Technology, 2005.
- [348] A. Pulgur, L. Divakar, R. K. Chethan Gowda, B. Nagesh, "Influence of steel fibres on mechanical properties of geopolymer concrete", in *Green Buildings and Sustainable Engineering, Proceedings of GBSE 2018*, Bd. 24, Singapore, 2018, doi: 10.1007/978-981-13-1202-1\_36.
- [349] A. König, A. Wuestemann, F. Gatti, L. Rossi, F. Fuchs, D. Fessel, F. Dathe, F. Dehn, F. Minelli, "Flexural behaviour of steel and macro-PP fibre reinforced concretes based on alkali-activated binders", *Construction and Building Materials*, 211, 2019, pp. 583-393, doi: 10.1016/j.conbuildmat.2019.03.227.
- [350] V. C. Li, "Engineered Cementitious Composites (ECC) - Material, Structural, and Durability Performance," in *Concrete Construction Engineering Handbook*, CRC Press, 2008.
- [351] V. Li, "On Engineered Cementitious Composites (ECC) - A review of the material and its applications", *Journal of Advanced Concrete Technology*, 1(3), 2003, pp. 215-230, doi: 10.3151/jact.1.215.
- [352] B. Nematollahi, J. Qiu, E.-H. Yang, J. Sanjayan, "Micromechanics constitutive modelling and optimization of strain hardening geopolymer composite", *Ceramics International*, 43(8), 2017, pp. 5999-6007, doi: 10.1016/j.ceramint.2017.01.138.

- [353] B. Nematollahi, J. Sanjayan, F. U. A. Shaikh, "Matrix design of strain hardening fiber reinforced engineered geopolymer composite", *Composites Part B*, 89, 2016, pp. 253-265, doi: 10.1016/j.compositesb.2015.11.039.
- [354] F. U. A. Shaikh, "23 - Fibre-reinforced geopolymer composites (FRGCs) for structural applications", in *Advances in Ceramic Matrix Composites*, W. Publishing, Ed., I.M. Low, 2018, pp. 569-593.
- [355] F. U. A. Shaikh, A. Fairchild, "Strain hardening behaviour of polyethylene fibre reinforced ambient air cured geopolymer composite", in *Strain-Hardening Cement-Based Composites (SHCC4)*, Springer, 2018, pp. 162-171, doi: 10.1007/978-94-024-1194-2\_19.
- [356] F. F. Wafa, "Properties and applications of fiber reinforced concrete", *Engineering Sciences Journal*, 1990, pp. 49-63.
- [357] M. Reed, W. Lokuge, W. Karunasena, "Fibre-reinforced geopolymer concrete with ambient curing for in situ applications", *Journal of Materials Science*, 49(12), 2014, pp. 4297-4304, doi: 10.1007/s10853-014-8125-3.
- [358] S. Kramar, A. Šajna, V. Ducman, "Assessment of alkali activated mortars based on different precursors with regard to their suitability for concrete repair", *Constr Build Mater*, 124, 2016, pp. 937-944, doi: 10.1016/j.conbuildmat.2016.08.018.
- [359] M. Van Sante, "Soaring gas prices will raise the cost of some building materials", ING, 2021, Available at: <https://think.ing.com/articles/soaring-gas-prices-will-raise-the-cost-of-some-building-materials/>.
- [360] A. Morby, Industry to be hit with 16% cement price hike, *Construction Enquirer News*, 2021, Available at: <https://www.constructionenquirer.com/2021/11/01/industry-to-be-hit-with-16-cement-price-hike/>.
- [361] F-CE, The revised EU ETS can accelerate the decarbonisation of cement, *Foresight*, 2à21, Available at: <https://foresightdk.com/the-revised-eu-ets-can-accelerate-the-decarbonisation-of-cement/>.
- [362] InformationsZentrum Beton, Umweltproduktdeklaration C25/30, Accessed Sep. 2018: <https://www.beton.org/wissen/nachhaltigkeit/umweltproduktdeklarationen/>.
- [363] CEMBUREAU, Environmental Product Declaration (EPD) for Portland-composite cement (CEM II) produced in Europe, Accessed Feb. 2020: <https://www.cembureau.eu/media/f2ubx2lk/epd-for-cement-cem-ii.pdf>.
- [364] GCCA, "Getting the numbers right" database [https://gccassociation.org/gnr/EU28/GNR-Indicator\\_25aAGFC-EU28.html](https://gccassociation.org/gnr/EU28/GNR-Indicator_25aAGFC-EU28.html).
- [365] GCCA, "Getting the numbers right" database [https://gccassociation.org/gnr/EU28/GNR-Indicator\\_92AGW-EU28.html](https://gccassociation.org/gnr/EU28/GNR-Indicator_92AGW-EU28.html).
- [366] GCCA, "Getting the numbers right" database [https://gccassociation.org/gnr/EU28/GNR-Indicator\\_33AGW-EU28.html](https://gccassociation.org/gnr/EU28/GNR-Indicator_33AGW-EU28.html).
- [367] [ISO 14040] ISO 14040:2006 - Environmental management - Life cycle assessment - Principles and framework.
- [368] [EN 206] EN 206:2013+A2:2021 Concrete - Specification, performance, production and conformity.
- [369] [EN 15804] EN 15804:2012+A2:2019 - Sustainability of construction works - Environmental product declarations - Core rules for the product category of construction products.
- [370] [EN 16908] EN 16908:2017 - Cement and building lime - Environmental product declarations - Product category rules complementary to EN 15804.
- [371] [EN 16757] EN 16757:2017 - Sustainability of construction works - Environmental product declarations - Product Category Rules for concrete and concrete elements.

- [372] J. Mukkavaara, M. Sandberg, K. Sandberg, A. Pousette, J. Norén, “Sustainability evaluation of timber dwellings in the north of Sweden based on environmental impact and optimization of energy and cost”, *Procedia Manufacturing*, 44, 2020, pp. 76-83, doi: 10.1016/j.promfg.2020.02.207.
- [373] EFCA, About Admixtures, European Federation of Concrete Admixtures, Accessed Dec. 2022: <http://www.efca.info/admixtures>.
- [374] J. L. Provis, K. Arbi, S. A. Bernal, D. Bondar, A. Buchwald, A. Castel, “RILEM TC 247-DTA Round Robin Test : Mix design and reproducibility of compressive strength of alkali-activated concretes”, *Mater. Struct.*, 2019, #0123456789, pp. 1–22, doi: 10.1617/s11527-019-1396-z.
- [375] A. Komkova, G. Habert, “Environmental impact assessment of alkali-activated materials: Examining impacts of variability in constituent production processes and transportation”, *Constr. Build. Mater.*, 363, 2023, #129032, doi: 10.1016/J.CONBUILDMAT.2022.129032.
- [376] G. Habert, C. Ouellet-Plamondon, “Recent update on the environmental impact of geopolymers”, *RILEM Tech. Lett.*, 17(1), 2016, doi: 10.21809/rilemtechlett.v1.6.
- [377] Leiden University, CML-IA Characterisation Factors - Leiden University, 2022, Accessed December 2022: <https://www.universiteitleiden.nl/en/research/research-output/science/cml-ia-characterisation-factors>.
- [378] C. Chen, G. Habert, Y. Bouzidi, A. Jullien, A. Ventura, “LCA allocation procedure used as an incitative method for waste recycling: An application to mineral additions in concrete”, *Resour. Conserv. Recycl.*, 54, 2010, pp. 1231–1240, doi: 10.1016/j.resconrec.2010.04.001
- [379] A. Heath, K. Paine, M. McManus, “Minimising the global warming potential of clay based geopolymers”, *J. Clean. Prod.*, 78, 2014, pp. 75–83. <https://doi.org/10.1016/j.jclepro.2014.04.046>.
- [380] C. Chen, G. Habert, Y. Bouzidi, A. Jullien, “Environmental impact of cement production: detail of the different processes and cement plant variability evaluation”, *J. Clean. Prod.*, 18, 2010, pp. 478–485, doi: 10.1016/j.jclepro.2009.12.014.
- [381] Euro Chlor, Chlor-alkali industry review 2019-2020, 2020, Accessed May 2021: [https://www.chlorineindustryreview.com/wp-content/uploads/2020/09/Industry-Review-2019\\_2020.pdf](https://www.chlorineindustryreview.com/wp-content/uploads/2020/09/Industry-Review-2019_2020.pdf).
- [382] P. Van Den Heede, N. De Belie, “Environmental impact and life cycle assessment (LCA) of traditional and “green” concretes: Literature review and theoretical calculations”, *Cem. Concr. Compos.*, 34, 2012, pp. 431–442, doi: 10.10j.cemconcomp.2012.01.004.
- [383] EU, European green deal: Striving to be the first climate-neutral continent, European Union, 2019.
- [384] UN, Paris Agreement to the United Nations Framework Convention on Climate Change, United Nations Climate Change, Dec. 12, 2015, T.I.A.S. No. 16-1104.
- [385] EU, Circular Economy Action Plan: For a cleaner and more competitive Europe, European Union, 2020.
- [386] S. Witjes, R. Lozano, "Towards a more Circular Economy: Proposing a framework linking sustainable public procurement and sustainable business models", *Resources, Conservation and Recycling*, 112, 2016, pp. 37-44, doi: 10.1016/j.resconrec.2016.04.015.
- [387] B. Bakker, S. Habets, S. Matthys, J. Provis, B. Holt Andersen, URBCON – Policy review, URBCON project (Interreg NWE), 2021, 54 p., doi: 10.5281/zenodo.8034407
- [388] A. Palomo, P. Krivenko, I. Garcia-Lodeiro, E. Kavalerova, O. Maltseva, A. Fernández-Jiménez, “A review on alkaline activation: new analytical perspectives”, *Materiales de Construcción*, 64(315), 2014, doi: 10.3989/mc.2014.v64.i315.

- [389] F. Pacheco-Torgal, J. Castro-Gomes, S. Jalali, "Alkali-Activated Binders: A Review Part 1. Historical Background, Terminology, Reaction Mechanisms and Hydration Products", *Construction and Building Materials*, 22, 2008, vpp. 1305-1314, doi: 10.1016/j.conbuildmat.2007.10.015.
- [390] J. L. Provis, "Geopolymers and other alkali activated materials: why, how, and what?", *Mater Struct*, 47, 2014, pp. 11–25, doi: 10.1617/s11527-013-0211-5.
- [391] A. Buchwald, M. Vanooteghem, E. Gruyaert, H. Hilbig, N. De Belie, "Purdocement: application of alkali-activated slag cement in Belgium in the 1950s", *Mater Struct*, 48, 2015, pp. 501–511, doi: 10.1617/s11527-013-0200-8.
- [392] C. Shi, P. V. Krivenko, D. Roy, *Alkali-activated cements and concretes*, London: Taylor & Francis, 2006.
- [393] K. Yang, C. Yang, J. Zhang, Q. Pan, L. Yu, Y. Bai, "First structural use of site-cast, alkali-activated slag concrete in China", *ICE Proceedings Structures and Buildings*, 171(10), 2017, pp. 1-10, doi:10.1680/jstbu.16.00193.
- [394] J. Konarik, J. Bohacova, "Review of practical applications of alkali-activated systems in construction", 2018 IOP Conf. Ser.: Mater. Sci. Eng., 385, 2018, #012030, doi: 10.1088/1757-899X/385/1/012030.
- [395] B. Tempest, C. Snell, T. Gentry, M. Trejo, K. Isherwood, "Manufacture of full-scale geopolymer cement concrete components: A case study to highlight opportunities and challenges", *PCI*, 60(6), 2015, pp. 39-50, doi: 10.15554/pcij.11012015.39.50.
- [396] T. Glasby, J. Day, R. Genrich, J. Aldred, "EFC geopolymer concrete aircraft pavements at Brisbane West Wellcamp Airport", *Concrete 2015*, 2015, pp. 1-9.
- [397] J. Aldred, J. Day, "Is Geopolymer Concrete a Suitable Alternative to Traditional Concrete?", 37th Conference on Our World in Concrete & Structures, 29-31 August 2012, Singapore, 2012.
- [398] R. Patel, F. Kinney, G. Schumacher, "Green concrete using 100% fly ash based hydraulic binder", 2012 International Concrete Sustainability Conference, Seattle, WA, 2012, 14 p.
- [399] *Beyond Zero Emissions, Zero Carbon Industry Plan Rethinking Cement*, 2017, ISBN: 978-0-9923580-2-0.
- [400] M. Tanaka, "How to Construct a Zero Waste, Recycling Society", 5th UCLG ASPAC Congress, 4 September 2014, Taipei, Taiwan, 2014.
- [401] K. Yang, C. Yang, J. Zhang, Q. Pan, "First structural use of site-cast, alkali-activated slag concrete in China", *ICE Proceedings Structures and Buildings*, 171(10), 2017, pp. 1-10, doi: 10.1680/jstbu.16.00193.



# INDEX

AAM .....	15, 28, 51	carbonation.....	73
AAM concrete .....	16, 65	CASH gel .....	52
AAM in Asia .....	152, 155	cement .....	21, 22
AAM in Australia .....	153	chloride resistance.....	74
AAM in Europe .....	150, 152, 154	circular construction, circular building .....	
AAM in former Sovjet Union.....	151	.....	18, 126, 176
AAM in USA.....	152, 154	citizens, reading guide .....	13
AAM industry .....	83, 103	clinker.....	22
AAM repair mortar.....	96	CO <sub>2</sub> emissions .....	20, 28, 115
activator .....	28, 51, 62	compressive strength .....	70
aggregates.....	29, 30	concrete .....	14, 65
air cooled blast furnace slag (ABS).....	41	concrete mixture.....	16
alkali-activated binders.....	28	concrete mixture, AAM.....	16, 65
alkali-activated concrete (AAC).....	16, 65	construction and demolition waste (CDW) ..	30
alkali-activated material (AAM) .....	15, 28, 51	construction companies, reading guide .....	13
alkali-silica reaction (ASR) .....	80	construction minerals .....	20, 40
amorphous-like gels (CASH, NASH).....	51	cost.....	103
applications, AAM .....	150	crushed concrete .....	29
applications, metallurgic slag.....	44	curing .....	69, 80, 86
architects, reading guide .....	12	declarations of performance .....	44
ashes .....	59, 60	demonstrator, Delft .....	180
availability of by-products .....	57	demonstrator, Gent .....	168, 182
barriers for AAM .....	109, 126, 127	demonstrator, Kamp C Westerlo.....	176, 183
basic oxygen slag (BOS).....	42	demonstrator, Rotterdam .....	155, 180
basis for design .....	86	design by testing.....	88
binder .....	21	design check list .....	88
blast furnace slag (BFS) .....	41, 55	design of AAM structures .....	86
bond strength .....	88, 94, 98	durability.....	72
by-products, biomass.....	49, 60	DuRSAAM (EU-project) .....	187
by-products, industrial.....	40	economic considerations.....	103
by-products, mining.....	48	emissions .....	20, 28, 105, 115
calcined clays .....	56	emissions trading system (ETS) .....	105
calcium aluminate cement (CAC).....	25	energy consumption concrete production .	106
calcium silicate hydrates (CSH) .....	51	engineers, reading guide .....	12
calcium sulfoaluminate cement (CSA) .....	24		

environmental product declarations (EPDs)	28, 51, 55
.....	116
ferrous slag.....	<i>see metallurgic slags</i>
fibre reinforced AAC (FRAAC) .....	92
flash setting.....	<i>see rapid setting</i>
fly ash (FA).....	47, 55
freeze-thaw resistance.....	77
fresh concrete behaviour.....	66
frost resistance.....	77
fuels concrete production.....	106
full-scale testing .....	88
geopolymer .....	28
geopolymer concrete.....	16
global warming potential (GWP) .....	110
granulated blast furnace slag (GBS or GBFS)	41
greenhouse gas emissions .....	20, 28, 105, 115
ground granulated blast furnace slag (GGBFS)	41
.....	41
hard coal fly ash .....	47
hardened properties of AAC .....	70
heavy metals .....	124
hydroxides.....	<i>see activators</i>
kaolin.....	48, 56
ladle slag .....	43
landlords, reading guide .....	12
leaching .....	110, 124
lessons learned .....	126, 135
life cycle .....	110
life cycle assessment (LCA) .....	110
load bearing .....	86, 88
low-carbon cement and concretes .....	105
market.....	103, 104
mechanical properties of AAC .....	70
metakaolin .....	56
metallurgic slags.....	40
microstructure .....	17, 51
minerals.....	<i>see construction minerals</i>
mix design .....	<i>see concrete mixture, AAM</i>
molar ratio .....	72
Municipal solid waste .....	59
NASH gel.....	52
non-ferrous slag .....	<i>see metallurgic slags</i>
PC concrete .....	65
phosphorous slag.....	59
policy making .....	126
Portland cement (PC).....	14, 21, 22
Portland clinker.....	22
precursor.....	28, 51, 55
pre-treatment .....	<i>see treatment</i>
primary raw materials.....	<i>see raw materials</i>
public authorities, reading guide .....	12
quality control.....	87
rapid setting.....	86
raw materials .....	20, 40, 83
reaction, binders.....	51
recycled aggregates .....	29, 30, 35
recycled URBCON concrete .....	35
red mud.....	61
repair mortar .....	82, 96
retarders .....	69
retrofitting .....	100, 102
rice husk.....	60
risks .....	<i>see barriers</i>
robustness of AAM mix.....	83
sand.....	<i>see aggregates</i>
secondary aggregates.....	29
secondary metallurgic slag (SMS).....	43
secondary raw materials.....	<i>see raw materials</i>
seismic retrofitting.....	100, 102
service life .....	18, 72
setting time.....	69
shrinkage.....	78
silicates.....	<i>see activators</i>
SiO <sub>2</sub> /Na <sub>2</sub> O ratio .....	72
slag .....	40
sodium hydroxide .....	<i>see activators</i>
sodium silicate (water glass).....	<i>see activators</i>
solid sewage sludge .....	60
standards .....	23, 96, 111
street furniture .....	180
strength.....	<i>see mechanical properties, design by testing</i>
structural.....	70, 82, 88, 96
students, reading guide .....	13
Sulphate resistance.....	75
superplasticizers .....	68
supplementary cementitious materials (SCMs)	26
.....	26
sustainable construction.....	<i>see circular construction</i>
temperature effect .....	83
tendering.....	126
tensile strength .....	70
test protocols.....	87

textile AAM .....	96	waste.....	<i>see by-products and CDW</i>
textile reinforced mortar (TRM) .....	96	wastewater treatment.....	60
treatment.....	40, 120	water to binder ratio .....	70
urban.....	14, 18, 59	workability, slump, flow.....	66
URBCON (EU-project).....	186	zeolite.....	28, 52, 53
URBCON concrete .....	20, 65		