

Speed Control of BLDC Motor fed from Solar PV Array using particle Swarm Optimization

B. Vadivel¹, Dr. J. Karthikeyan², V. Kanagasubramanian³

^{1,2,3}Dept. of Electrical and Electronics Engineering, Mangayarkarasi College of Engineering, Paravai, Madurai, India.

Received Date: 24 January 2022

Revised Date: 08 February 2023

Accepted Date: 10 February 2023

Abstract: Brushless DC Motors have recently discovered frequent usage in industrial applications due to their advantages over other AC motors. This paper basically talks about the speed control of a BLDC motor fed from a standalone Solar PV system with perturb and observes the MPPT method to extract the maximum efficiency. The Particle Swarm Optimization technique has been used to find the optimized result for the PID controller. The end result shows the PSO controller controls the speed of the BLDC motor quite well.

Keywords: Solar PV Array, P&O, MPPT, PSO, BLDC motor, PID Controller

I. INTRODUCTION

An Electronically Commutated Motor (ECM) or a Brushless DC Motor are synchronous motors whose AC supply is given through an Inverter or a Switching Power Supply to drive each motor phase. The BLDC motor is a permanent magnet motor in which solid-state switches are used to work as brushes or commutators.

Nowadays BLDC motors are the furthest common and widely used motors. It has numerous industrial and commercial application which includes aero modeling, positioning system, electric vehicles, peripheral devices, etc [6]. Its advantages include flat torque over a wide range of speeds, long operational lives, less bulky, comparatively quiet, required less raw material to build so is also better for the environment [3].

BLDC motor controlling implements the outdated brushes functionality which requires the rotor's position and orientation (w.r.t. stator coil). In it, rotor position can be measured directly by using Hall Effect sensors or a rotary encoder [11]. Back-EMF can be measured by others in the undriven coil to know the rotor position, this eliminates the use of a hall sensor, which is called a sensorless controller.

There is always been discussion about which controller is good and controls the system most effectively. There are a number of controllers including Fuzzy logic, PID controller, PI controller, Artificial Neural Networks etc. PID controller are the most widely used one in industries, it has a closed-loop system with a feedback path. P denotes the Proportional Gain which can be achieved by multiplying the error by a constant K_p . We notice a large change in the output when K_p is high for the same error.

- The system will become unstable when the value of K_p is too high.
- The system will become less responsive or less sensitive when the value of K_p is too small.

I denote the Integral Gain which is achieved by multiplying the error with the constant K_i and adding to the controller output. It helps the system to move towards a particular setpoint and eliminates the residual steady-state error. D denotes the Derivative Gain which can be calculated by analyzing the slope of the error over time and multiplying the rate of change with constant K_d . It determines the system behavior and improves the settling time and stability of the system.

Optimization algorithms are normally used to find the optimized parameters for the controller. Some of them are Genetic Algorithm (GA), Particle Swarm Optimization (PSO), Ant-Bee algorithm, Bacterial Forging Optimization (BFO) etc. GA and PSO are very popular optimization techniques, but many new techniques have also been analyzed for their feasibility. In this paper, we give a brief description of the Particle Swarm Optimization technique. It was first presented by Eberhart, Kennedy, and Shi, based on the social behavior of the animals such as flocks of birds and birds etc. . PSO is known as a computational method by which a problem is optimized by iteration technique to improve the solution. It is heuristic since it doesn't make assumptions about the problem which is being optimized and searches through a large number of solutions. In this paper, it has been used only to get the optimized PID controller's parameters i.e., K_p and K_i [1].

Renewable energy is preferred nowadays due to environmental conditions. Solar is one of the best renewable

energy sources among others. The solar PV array is best suited for this purpose among other sources of energy as it is available at every place, it has a long life, and requires less maintenance [9]. So Solar PV Array with Perturb and Observe the type of maximum power point tracking has been used to extract the maximum efficiency from the solar array [8]. There exist multiple MPPT techniques but many of them suffer from the disadvantage of slow tracking, which ends up reducing the efficiency of solar arrays [5]. Incremental Conductance (INC) and Perturbation and Observation (P&O) have been widely used methods.

II. REVIEW OF METHODOLOGY

The review of the paper shows the controlling of the BLDC motor using the methodology given as below:

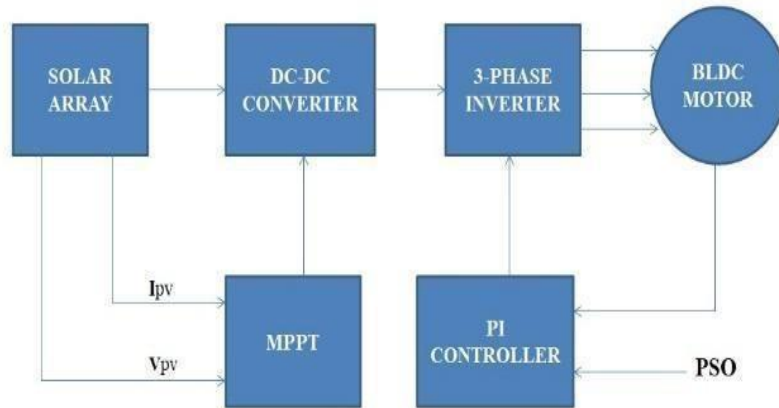

Figure 1: Block Diagram of Proposed Work

A. Solar PV Array

Mathematical Modeling of PV Cell A solar cell works on the principle of photoelectric effect i.e., when solar radiations falls on the semiconductor plate it produces electrical current. Solar Array mainly defines the combination of two or more solar cells connected either in series or in parallel to fulfil the energy requirement. Solar cells are usually connected in series to produce higher voltage and in parallel to produce higher current than the system.

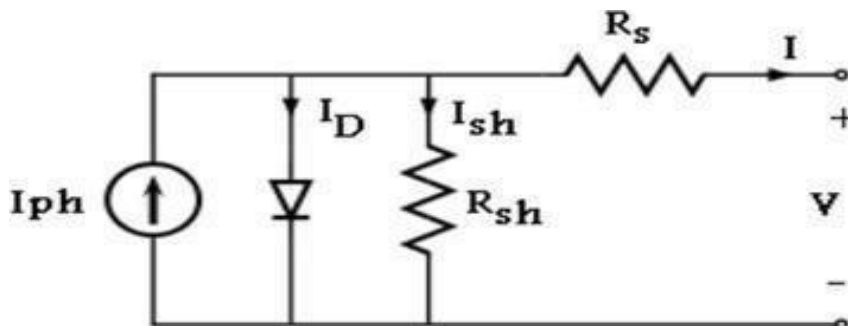

Figure 2: PV cell equivalent circuit It shows a basic equivalent circuit diagram of a Solar cell.

The equation can be developed to calculate the output current with the inputs of solar array i.e. voltage, solar irradiation and temperature.

$$I_{ph} = [I_{sc} + K_i(T - 298)] * I_r / 1000 \quad (1)$$

where,

I_{ph} = phase current

I_{sc} = short circuit current

K_i = I_{sc} of a cell at 25°C and 1000T = working temperature

I_r = solar's irradiation

Series resistance are taken into account due to combined resistances of contacts, metal grips and p and n layers. Shunt resistance are considered due to leakage current through p-n junction.

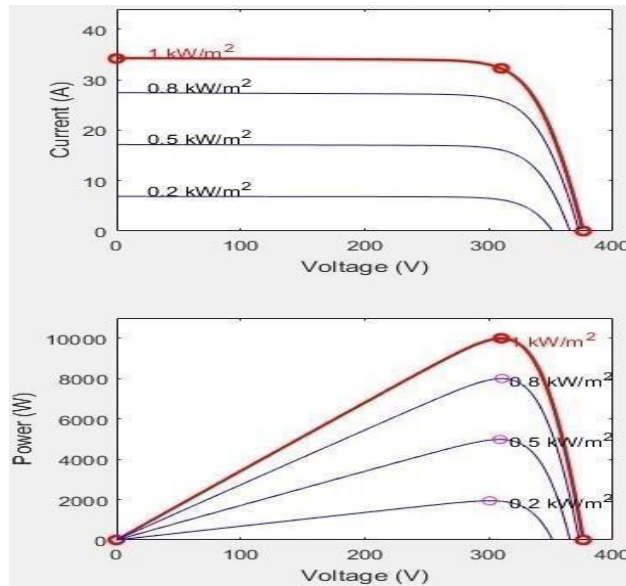

Figure 3: I-V and P-V Characteristic of Solar Array

The figure 2 is short-circuited making the output voltage, $V=0$ and current is maximum, $I=I_S/C$ hence V-I characteristic can be plotted. When fig 2. is open circuited then output voltage is maximum, $V=V_O/C$ and current, $I=0$ hence P-V characteristic is plotted.

B. Maximum Power Point Tracking (MPPT)

Maximum Power Point Tracking / Power Point Tracking can be used to maximize the output power of the solar cell under all conditions [3]. Solar cell derives a relationship between temperature and resistance which produces non-linear output efficiency and its analysis can be seen on P-V curve [10]. Now the MPPT is being used to get the sampled output from solar cells and therefore proper resistance is applied or load through which maximum power can be obtained. The power at the MPP (P_{mpp}) can be calculated as the MPP voltage (V_{mpp}) and MPP current's (I_{mpp}) product. The MPPT technique used to calculate MPP voltage (V_{mpp}) through temperature of the solar module and then compares it with reference voltage. There is basically no change in MPP voltage when irradiation is changed, hence its influence can be ignored and the voltage changes linearly when there is a change in temperature. MPPT mainly regulates the output obtained from the solar pv array and provide that output to the DC-DC converter or the inverter circuit. The maximum power (P_{mpp}) can be calculated by multiplying MPP voltage (V_{mpp}) and MPP current (I_{mpp}).

Now to calculate voltage we have following equation:

$$V_{mpp}(T) = V_{mpp}(T_{ref}) + u_{v_{mpp}}(T - T_{ref}) \tag{2}$$

where:

V_{mpp} = mpp voltage at stated temperature T_{ref} = temperature taken as reference T = temperature which is measured

u_p = temperature's coefficient

MPPT have several strategies which can be used to optimize the output power of the solar pv array. One may implement different algorithms and switch among those based on operating condition of the solar array. Some of them includes Perturb and Observe, Incremental Conductance, Current Sweep, Constant Voltage, Temperature Method etc. Among them perturb and observe and incremental conductance methods are the most commonly used ones. However, this paper deals with the perturb and observe method to extract the maximum efficiency from the solar array.

In this technique, a minor perturbation is introduced in voltage to cause the power variation of the PV module. Then PV output power is periodically measured and compared with the previous power. Now, if output power increases same process is continued else the perturbation is reversed. So mainly, the PV module voltage is increased.

The resulting change of PV power is observed as follow:

If dp/dv is positive, the perturbation of voltage should be increased from point "A" towards MPP. If dp/dv is negative, the perturbation of voltage should be increased from point "B" towards MPP.

This process is repeated until it is reached to MPP (max pow) where $\frac{dP}{dV}$ is zero, hence this satisfied termed as steady state.

It keeps perturbing the system until a change is detected in the MPP.

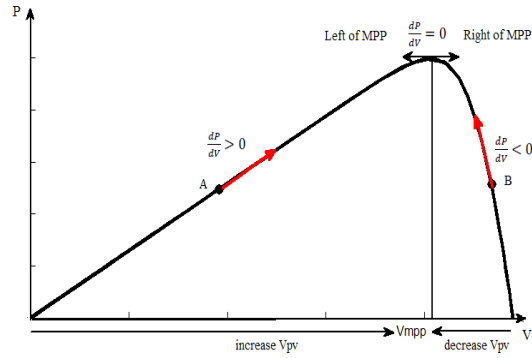

Figure 4: Perturb and Observe on P-V curve

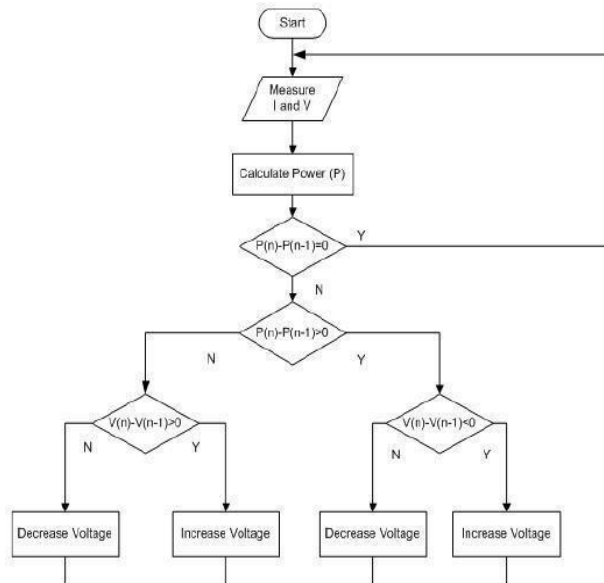

Figure 5: Perturb and Observe flowchart On the basis of the above P-V curve

We can determine the MPP as follows:

- When an increase in voltage leads to increase in power, this means that the operating point of the PV module is on the left of MPP. Hence, further perturbation is required in the right to reach the mpp.
- When an increase in voltage leads to decrease in power, this means that the operating point of the PV module is on the right of MPP. Hence, further perturbation is required towards the left to reach the mpp.
- Hence PWM duty cycle is increased or decreased to extract the maximum power.

C. Brushless DC Motor

BLDC motors are permanent magnet motors which uses solid state switches in place of commutators and brushes. The bldc motors are not only distinguished from other motors by high efficiency but also due to low maintenance.

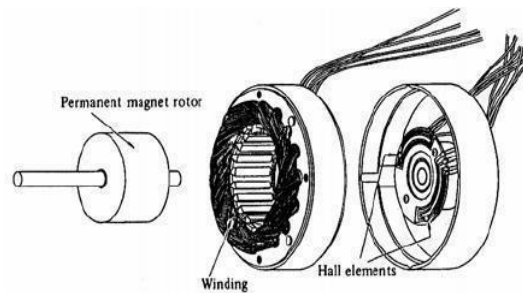

Figure 6: Disassembled view of BLDC motor

The construction of BLDC motor is similar to that of AC motors, hence also known as permanent magnet synchronous motor. The stator winding is similar to those in a polyphase AC motor, and rotor consist of one or more

permanent magnets. BLDC motor incorporates some means to detect the rotor position and produce signals to control the electronic switches. Hallsensors are hence most commonly used, while some also use optical sensors. BLDC motor equivalent circuit is shown below:

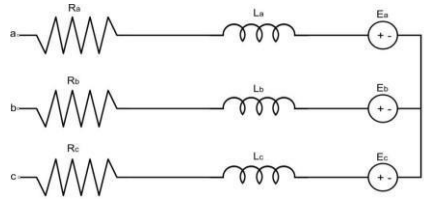

Figure 7: Typical Equivalent Circuit of BLDC Motor

In this we are considering phase A at the time of modeling. Hence equivalent circuit is shown in the figure V_a , terminal voltage can be taken as V_d :

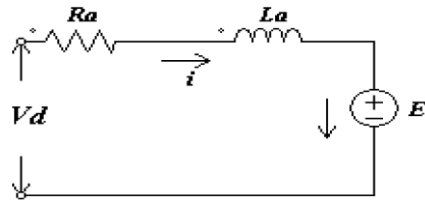

Figure 8: Per Phase equivalent of BLDC motor

Now phase current in the above model is obtained by applying given equations:

$$\frac{di_a}{dt} = \frac{1}{L-M} (V_a - E_a - Ri_a) \tag{3}$$

$$\frac{di_b}{dt} = \frac{1}{L-M} (V_b - E_b - Ri_b) \tag{4}$$

$$\frac{di_c}{dt} = \frac{1}{L-M} (V_c - E_c - Ri_c) \tag{5}$$

By using Kirchhoff's voltage law in the above circuit we get,

$$V_d = R_a i + L_a \frac{di}{dt} + E \tag{6}$$

The electromagnetic torque, T can be stated as follows:

$$T = J \frac{d\omega_m}{dt} + B\omega_m + T_L \tag{7}$$

Where,

- T=total electromotive force (Nm)
- J=moment of inertia(Kg-m²)
- B=viscous friction coefficient
- ω_m =rotor angular velocity(rad/s)
- T_L =load torque(Nm)

D. Particle Swarm Optimization(PSO)

The main function of an optimization algorithm is to find the best result for the controller circuit. Lately, there has been discussion about the effectiveness and usage of optimization techniques. Although the result of all the algorithms depend upon the size of the particles. But among the many Genetic Algorithm (GA) and PSO proves to be better. Also, PSO proves to be more efficient and fast as compared to GA for smaller number of particles. It happens due to the differences in the algorithm in both the optimization techniques.

PSO is an intelligent optimization algorithm which belongs to the meta-heuristic class of optimization algorithm. It is mainly inspired by the social behaviour of the animals such as birds and fishes. It uses some intelligent agent called particles which is used to reach another level of intelligence.

Now every particle has a position (X_i) in the search space denoted by; $X_i^t = (x_{i1} \ x_{i2} \ x_{i3} \dots \ x_{in})^T$

And the velocity (V_i) which describes the movement in the sense of direction and distance denoted by; $V_i^t = (v_{i1} \ v_{i2} \ v_{i3} \dots \ v_{in})^T$

Every particle has a memory of its best position in the respect of position and velocity which is known as

local best or personal best denoted as Pbest. The common best experience among the whole swarm is known as global best denoted as Gbest. These vectors are also updated for the dimension i.e. j, according to the given equation. So, the velocity can be updated by the given equation:

$$V_{ij}^{t+1} = \omega V_{ij}^t + c_1 r_1 (pbest_{ij} - X_{ij}^t) + c_2 r_2 (gbest_j - X_{ij}^t) \quad (8)$$

And, the position can be updated by the given equation:

$$X_{ij}^{t+1} = X_{ij}^t + V_{ij}^{t+1} \quad (9)$$

where,

$i=1, 2, \dots, P$

$j=1, 2, \dots, n.$

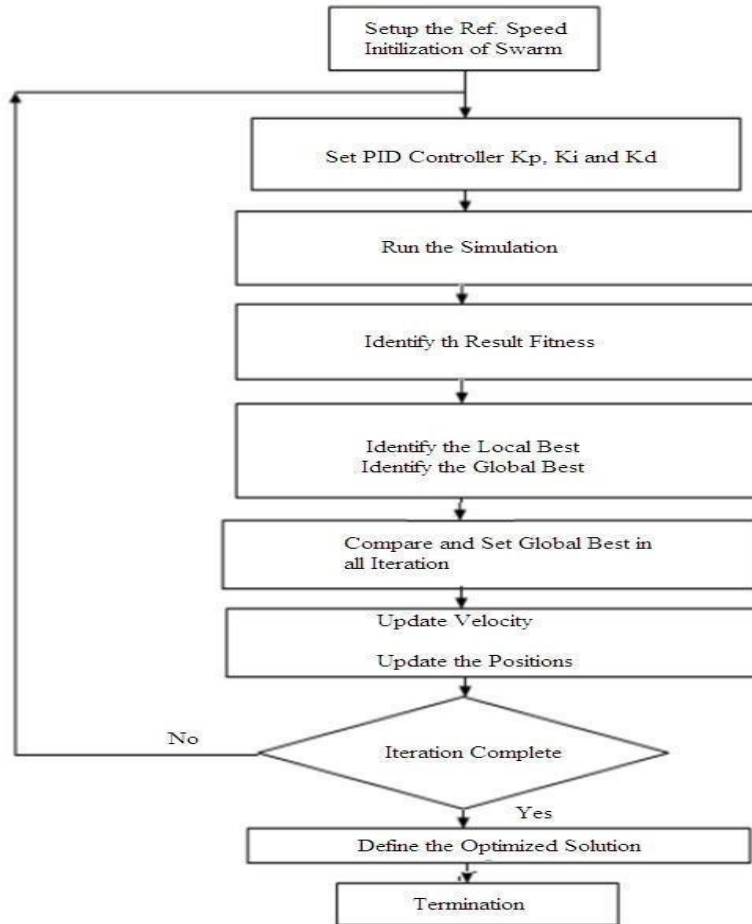

Figure 9: PSO Algorithm for tuning of BLDC Motor Controller

The equation 12 consists of three components i.e., Inertia term, Cognitive component and Social component. All the three components help in updating the velocity for PSO.

III. RESULT AND CONCLUSION

This paper deals with the speed control of BLDC motor fed from a solar PV array using Particle Swarm Optimization technique. So, a comparison has been made between the two model i.e., model of a BLDC motor with PSO and model of motor with solar array and PSO.

A. Model of BLDC motor with PSO

The entire system has been provided a set voltage source in this case. In this model, a PSO was used to determine the optimal parameters for the PI controllers, Kp and Ki, which help control the speed of the BLDC motor via a three-inverter.

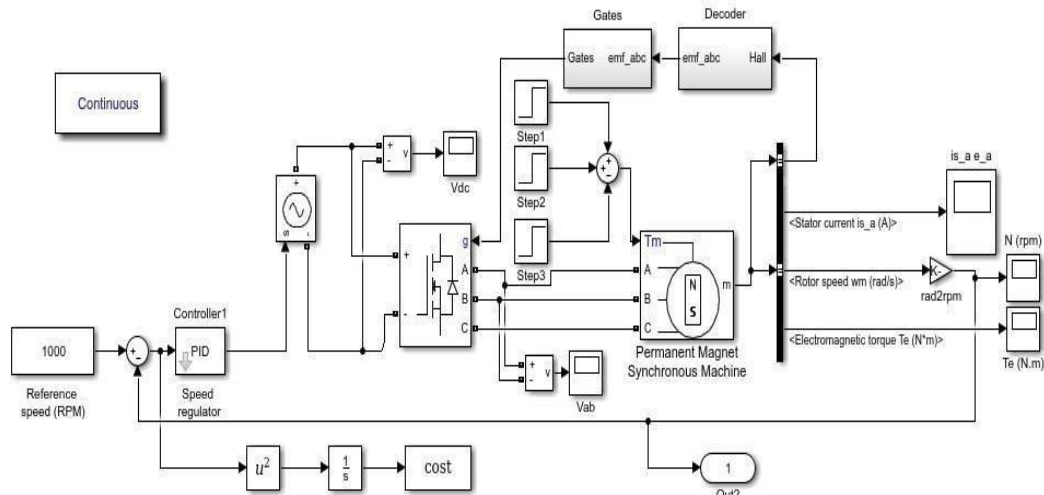

Figure 10: Model of BLDC motor with PSO

The parameters for the simulation can be stated as follows:

Table 1: Simulation Parameters

BLDC motor parameters		PSO parameters	
R	0.7Ω	w	0.9
L	2.72e-3H	c1	0.12
J	0.8e-3kg.m ²	c2	1.2
F	1e-3N.m. s	Number of particles	50
P	3	Maximum iteration	50

These parameters can be changed according to the requirement and usage. The parameter for the optimization technique can be increased to get the better results.

B. Simulation of BLDC Motor with PSO

When the system is coupled to a fixed voltage supply, the rotor speed of the BLDC motor is shown in the diagram.

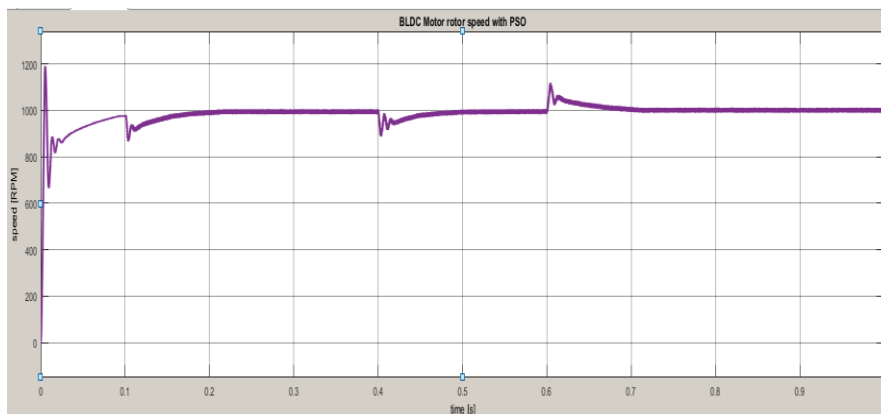

Figure 11: BLDC Motor Rotor Speed with PSO

PSO finds the most optimized result for PI controller to control rotor speed. Reference speed has been set to 1000rpm and the optimized value for $K_p=0.1850$ and $K_i=18.3602$ and system took approximately 0.6 seconds to reach the steady state and rise time. Result does have maximum overshoot and transients as can be clearly seen.

C. Model of BLDC motor with Solar PV Array and PSO

A solar PV array has been added to the system to provide power to the entire setup. Using the MPPT approach, the array's maximum efficiency may be retrieved. To produce the desired output for the 3-inverter, a dc-dc converter was also used.

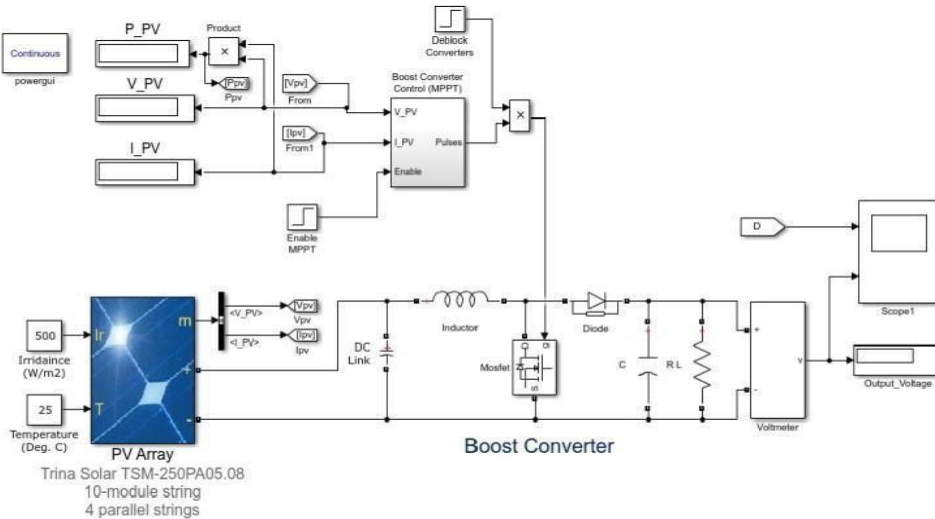

Figure 12: Model of BLDC motor with solar array and PSO

D. Simulation of BLDC Motor with Solar Array and PSO

In this, unlike of the previous one solar PV array has been used to power the system with all the other parameters keeping same and reference speed has been set to 1000rpm.

Although some new techniques has been used as shown in the fig 10. DC-DC converter has been used to get the desired input for the inverter system. Using these techniques have relatively improved the result. Hence, in this we are not facing any problem related with the maximum overshoot or the transients. In the results, there is no overshoot and no transients, rise time has also been decreased to as low as 0.25 seconds as shown in the figure

(a) BLDC Motor Rotor Speed with PSO

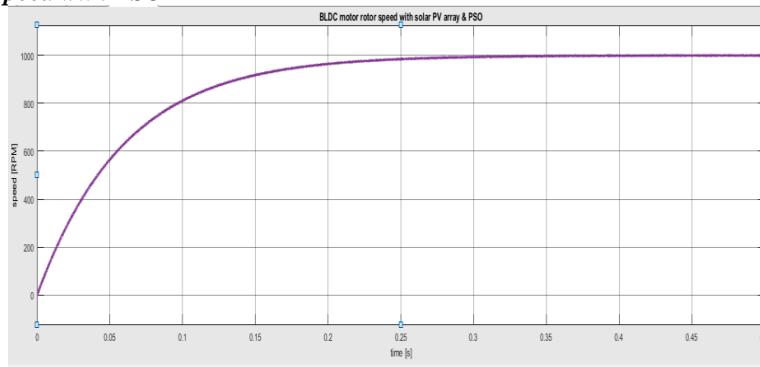

(b) Stator current (ia)

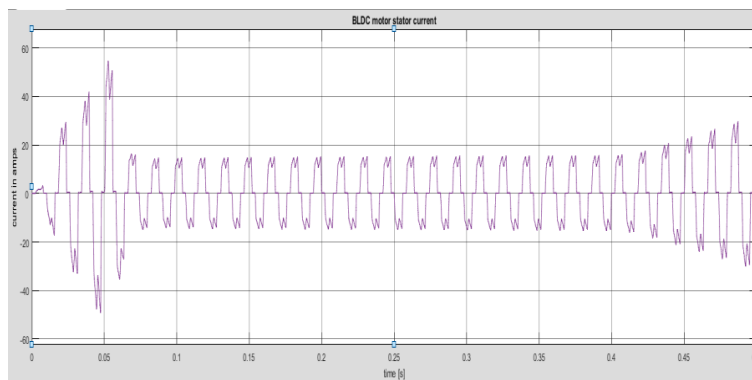

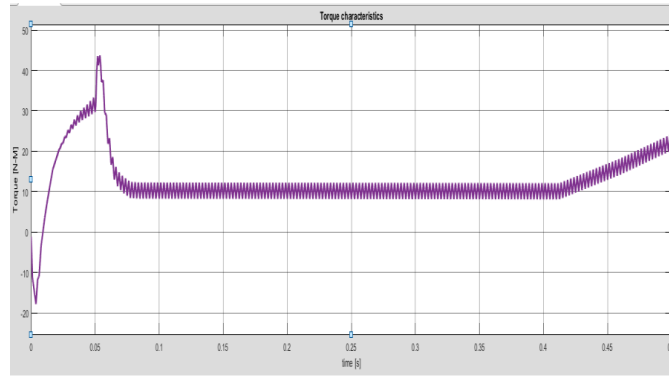

(c) Torque

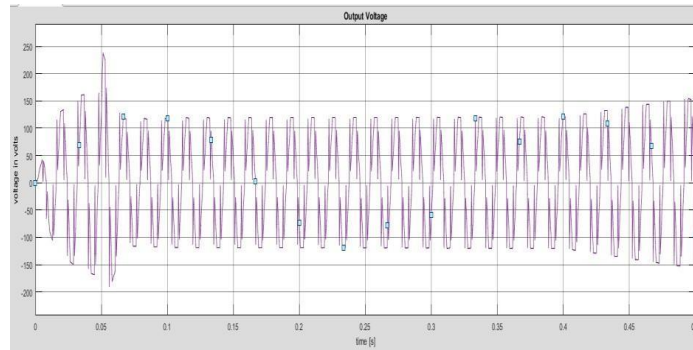

(d) Output Voltage

Figure 13: Graphs of BLDC motor with solar array and PSO

Fig 12(a) shows the rotor speed for BLDC motor with a rise time as low as 0.25sec. Fig 12(b) shows stator current with a peak value of 60A. Fig 12(c) shows torque and Fig 12(d) is output voltage with a value of 120V.

Table 2: Comparison of both the models at speed

ReferenceSpeed (nref)	With PSO		With PSO & Solar PV array	
	Rise time (tr)	Overshoot(%)	Rise time (tr)	Overshoot(%)
1000 rpm	1.5 sec	19.88	0.25 sec	0

Above table shows the comparison of rise time of rotor speed for both the models at 1000rpm as reference speed.

IV. CONCLUSION

In this paper, a contrast has been shown between the model of the BLDC motor with PSO and the model of the BLDC motor with the solar PV array and PSO. The rotor speed of the BLDC motor of both models has been compared. The graphs show that the rotor speed of the BLDC motor with the solar array and PSO has a good speed response with no overshoot and less rise time when compared with the other model. Hence, the result shows that the Solar fed controller based on PSO can control the BLDC motor speed pretty well.

V. REFERENCES

- [1] Jubaer Ahmed, Zainal Salam “A Modified P&O Maximum Power Point Tracking Method with Reduced Steady State Oscillation and Improved Tracking Efficiency” IEEE Transactions on Sustainable Energy Volume: 7 , Issue: 4, Oct. 2016:
- [2] Mohamad Ridwan, Dedet Candra Riawan and Heri Suryoatmojo “Particle Swarm Optimization-Based BLDC Motor Speed Controller with Response Speed Consideration” IEEE conference on Intelligent Technology and its Application (ISITIA), pages 193-198, Surabaya, Indonesia,2017:
- [3] Prakash Salawria, Rakesh Singh Lodhi and Pragya Neeema “Implementation of PSO-Based Optimum Controller for Speed Control of BLDC Motor” International Journal of Electrical, Electronics and Computer Engineering 6(1): 104-109(2017):
- [4] P. Mahesh, V.Ramaiah “Induction Motor Driven Solar PV Array Fed Water Pumping System with Zeta Converter” International Journal of Electronics, Electrical and Computational System (IJECS) ISSN2348-117X Volume 6, Issue 6 June 2017:
- [5] Rajan Kumar and Bhim Singh “BLDC Motor Driven Solar PV Array Fed Water Pumping System Employing Zeta Converter” IEEE Transactions on Industry Applications, Year: 2016, Volume: 52, Issue:3Pages: 2315 - 2322:
- [6] Sariki Murali, Kaibalya Prasad Panda and Gayadhar Panda “PV- HESS fed BLDC Driven Water Pumping System with PSO-based MPP Tracking Employing Zeta Converter” IEEE Innovative Smart Grid Technologies-Asia (ISGT-Asia), Pages:196-201, 2018:

- [7] S.Sakunthala, R.Kiranmayi, P.Nagaraju Mandadi “A study on industrial motor drives: Comparison and applications of PMSM and BLDC motor drives” International Conference on Energy, Communication, Data Analytics and Soft Computing (ICECDS), 2017:
- [8] S.Sarada, C.Ganesh and K.Aparna “Brushless DC (BLDC) motor drive for solar photovoltaic (SPV) array fed water pumping system by using Fuzzy Logic controller” International Journal of Electrical Engineering. ISSN 0974-2158 Volume 10, Number 3 (2017), pp. 289-305:
- [9] V.Mahes kumar, M.Bhuvanesh, S.Govindasamy, M.Yogaraj “Design and Implementation Of Solar PV fed BLDC Motor driven water pump using MPPT” International Journal of Scientific Engineering and Applied Science (IJSEAS) – Volume-4, Issue-03, March 2018:
- [10] Yu-kun Wang, Jie-sheng Wang “Optimization of PID Controller Based on PSO-BFO Algorithm” IEEE Chinese Control and Decision Conference, Yinchuan, China 20