

# Optimum tuning of the PID controller for Stable and unstable systems using nonlinear optimization technique

Fares Alariqi<sup>(1)</sup> , Adel Abdurrahman<sup>(2)</sup>

## ABSTRACT

Feedback has had a revolutionary influence in practically all areas where it has been used and will continue to do so; it desires a simple and effective feature of a control algorithm. The emerging features of automatic tuning have greatly simplified the use of PID controller; a nonlinear optimization technique based on sequential quadratic programming (SQP) technique is used for obtaining the tuning parameters of the PID controller. The proposed PID tuning based on SQP technique shows superiority and effectiveness in controlling stable and unstable nonlinear systems.

**Key words:** PID controller, nonlinear system, Optimization technique, SQP

## 1. Introduction

Feedback is a very powerful idea. Its use has often had revolutionary consequences with drastic improvements in performance, see [1, 2]. Credit is often given to a particular form of feedback although it is frequently feedback itself that gives the real benefits and the particular form of feedback used is largely irrelevant. Feedback desires a simple feature of a control algorithm: it should be widely applicable and easy to understand, involving as few tuning parameters as possible. Ideally, these parameters should possess a clear engineering meaning, making the tuning a systematic task according to the given specifications. Despite the developments of various kinds of modern or postmodern control theories, such as LQG or LQR optimal control, model predictive control (MPC), sliding mode control. The PID controllers are by far the most dominating form of feedback in use today, because of their simplicity, performance, robustness and availability of many effective yet simple tuning methods based on minimum plant model knowledge [2, 3].

---

<sup>1</sup> -Mechanical Engineering Department, Sana'a University, Yemen E-mail:f.alariqi@ust.edu.ye

<sup>2</sup> -Mechanical Engineering Department, Sana'a University, Yemen

The first attempts to automate the tuning of PID controllers were based on iterative manual tuning, and methods based on graphical time domain representation using root locus or frequency domain using bode plots [2, 4]. Ziegler and Nichols [5] have proposed their first reaction curves tuning rules which is based on calculating the controller parameters from the model parameters determined from the open loop system step response, and the ultimate cycle tuning rules which is based on calculation of controller parameters from the controller gain and oscillation period at the ultimate frequency. Then came the well known techniques such as Cohen-Coon method and internal model control method and other techniques which are called optimum methods [1, 2]. Recently, the Ziegler Nichols step response method has been considered by Astrom and Hggalund [6], where they analyzed analytically the power of the method and the recent modified methods based on it. There are many modified tuning methods that have also been proposed recently such as the PI/PID controller design based on IMC and percentage overshoot specification [7], a plant step response based technique [8], and the IMC-like analytical  $H_\infty$  design with S/SP mixed sensitivity consideration [9]. Moreover, a recent implementation aspect for building thermal control using PID has been considered by Kafetzis *et. al.* [10]. In addition, tuning rules for fractional PIDs has been proposed by Valerio and Costa [11], similar to the first and the second sets of tuning rules proposed by Ziegler and Nichols for integer PIDs.

All of the aforementioned tuning methods are only suitable to linear systems, but real time industrial processes are subjected to variation in parameters and parameter perturbations that make them highly stable or unstable nonlinear systems. Indeed, many industrial processes can be approximated sufficiently well in concerned operating region of state space by linear systems. However, many other plants exist whose dynamics must be described by nonlinear systems. Moreover, the aforementioned conventional tuning techniques lack the intelligence and flexibility which would increase the performance rate and also improve the stability and error criterion. Therefore, it is highly desirable to develop effective methods to determine the parameters of PID controllers for nonlinear systems. One way of controlling nonlinear systems is by considering them as a multi-input-multi-output system and applies conventional tuning rules to them [12], or using gain scheduling for different operating point and conventional tuning techniques for these operating points [1, 13]. There are several optimization

algorithms which have been used for searching the optimal gain parameters for the purpose of improved performance. A genetic algorithm for optimum tuning of PID controller is proposed by Ali *et. al.* [14, 15, 25] and to a fractional PID controller by Padhee *et. al.* [16]. Particle swarm optimization as soft technique has been proposed recently by different researchers [17, 18, 19], to obtain the optimum values of PID parameters for single input single output system, moreover, the semi-definite programming technique has been proposed by Bao *et. al.*[20] for tuning the multi-loop PID controller, where the PID tuning problem has been formulated as an  $H_{\infty}$  problem with a controller structure constraint and the controller parameters are optimised to achieve both user-specified robust stability and performance. Furthermore, neural network and fuzzy logic has got their successful implementation for designing a PID controller or as a controller based on PID's idea. Tan *et. al.* [21] has proposed a generalized nonlinear PID controller based on neural networks, and Chen and Huang [22] proposed an on-line tuning of PID controller based on neural network. While, fuzzy logic has been proposed by different researchers as a fuzzy gain scheduling of a double PID controller [23], a fuzzy controller [1], or fuzzy PID controller [24], for more review on the subject of PID tuning refer to [1, 2, 4, 6].

In this paper, we propose a nonlinear optimization technique based on sequential quadratic programming (SQP) technique for obtaining the parameters of the PID controller. In this approach, the tuning parameters of the PID controller are obtained to meet a time domain performance requirements of nonlinear system.

## 2. PID parameters tuning using SQP

A simple structure of control is the feedback control structure shown in figure 1., in this structure the automatic controller compares the actual value of the plant output with the reference input (desired value), determines the deviation, and produces a control signal that will reduce the deviation to zero or to small value.

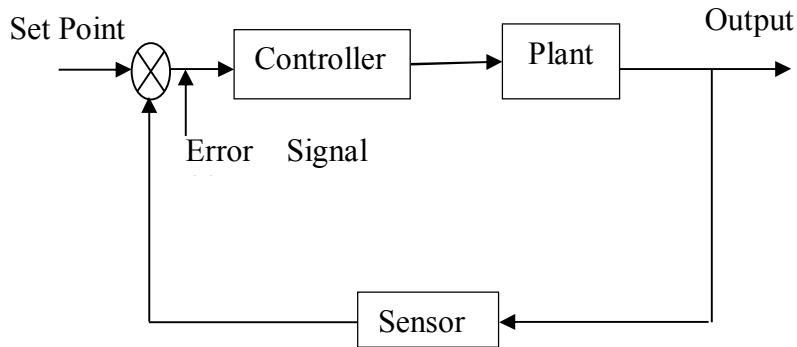

Figure(1): the feedback control structure

The control part in the mentioned structure could be PID controller, PID controllers are based on three basic behavior types: proportional (P), integral (I), and derivative (D). The proportional action provides control signal that is proportional to the error between the reference signal and the actual output. The integral action provides integral signal of the error, while the derivative action provide derivative signal of the error. The relation between the control  $u(t)$  and error  $e(t)$  can be expressed in the following form:

$$u(t) = K_p \left[ e(t) + \frac{1}{T_i} \int_0^t e(\tau) d\tau + T_d \frac{d}{dt} e(t) \right] \quad 1$$

$K_p$ ,  $T_i$ , and  $T_d$  are the parameters to be tuned. The corresponding transfer function is given by:

$$K(s) = K_p \left( 1 + \frac{1}{T_i s} + T_d s \right) \quad 2$$

There are several recommended methods for tuning PID controller parameters and for experimental determination of process characteristics used to obtain process variables and to set controller parameters [1, 2, 4, 6]. A continuous development of new control algorithms insure that the time of PID controller has not past and that this basic algorithm will have its part to play in process control foreseeable future [1, 14, 18, 23]. The nonlinear control design (NCD) blockset (MatLab Toolbox) is used for obtaining the final values for the tuned parameters of the PID controller. The NCD blockset enables tuning parameters within a nonlinear Simulink model to meet time domain performance requirements using a nonlinear optimisation technique. The NCD blockset transforms the constraints along with the

simulated system output into an optimisation problem of the following form:

$$\min_{x,\gamma} \gamma \quad s.t. \begin{cases} g(x) - w\gamma \leq 0 \\ x_l \leq x \leq x_u \end{cases} \quad 3$$

Where, the variable  $x$  is a vectorisation of the tunable variables ( $K_p$ ,  $T_i$ , and  $T_d$ ); while  $x_l$  and  $x_u$  are vectorisations of the lower and upper bounds on the tunable variables. The vector  $g(x)$  is a vectorisation of constraint bound error and  $w$  is a vectorisation of weighting on constraints.

The NCD blockset attempts to minimise the maximum constraint error using sequential quadratic programming (SQP) optimisation algorithm. The SQP optimisation algorithm employs quasi-Newton's method to directly solve the Karush-Kuhn-Tucker (KKT) condition for the original problem. As a result, the accompanying sub-problem turns out to be the minimisation of quadratic approximation to the Lagrangian function optimised over a linear approximation to the constraints.

### 3. Application of the PID tuning method to stable system

In the present work the PID controller has been applied to stable nonlinear system (stirred tank heat exchanger) that was studied by Abdulrahman [3]. The goal of this process is to control the dynamic response of the tank temperature subjected to a change in the coolant flow rate.

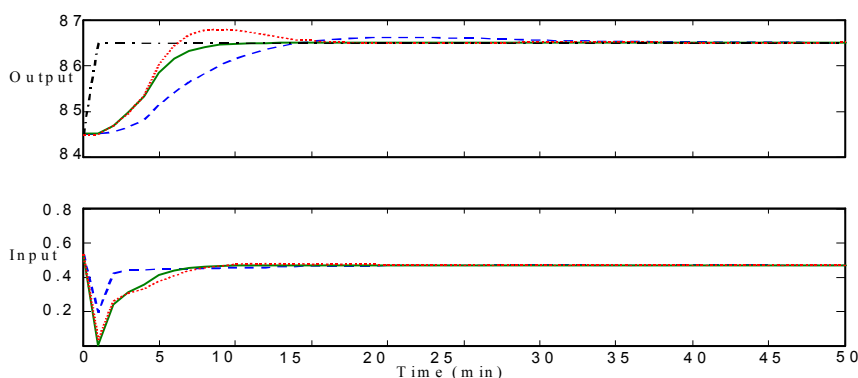

Figure(2): Closed-loop response for non-linear system with PID controller parameters based on relay feedback (dotted line), a plant step response based technique (dashed line) and NCD (solid line).

The PID controller has been tuned using the NCD block set to give the desired response shown in the figure above.

#### 4. Application of the PID tuning method using the NCD block set to unstable system

The tuning method has been applied to an inverted pendulum shown in figure 3. The inverted pendulum system inherently has two equilibria, one of which is stable while the other is unstable. The stable equilibrium corresponds to a state in which the pendulum is pointing downwards. In the absence of any control force, the system will naturally return to this state. The stable equilibrium requires no control input to be achieved and, thus, is uninteresting from a control perspective.

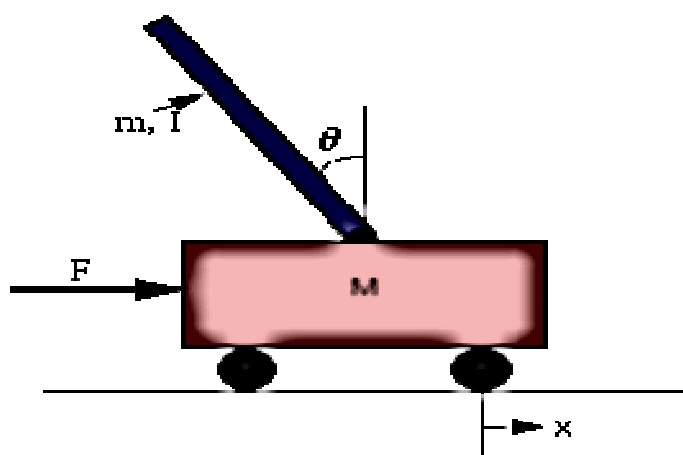

Figure(3): Free body diagram of the Inverted Pendulum

The unstable equilibrium corresponds to a state in which the pendulum points strictly upwards and, thus, requires a control force to maintain this position. The basic control objective of the inverted pendulum problem is to maintain the unstable equilibrium position when the pendulum initially starts in an upright position.

For controlling this unstable system, not all of the tuning methods mentioned above in figure 2 can be used, because are designed for stable systems. Tuning of PID parameters of this unstable system can be done with the help of the NCD tool box which is based on nonlinear optimization techniques.

For the purpose of PID parameters tuning, the NCD block has been used to control the angle of the cart to the desired response and get a good initial response as shown in figure 4, after that another NCD block has been used to control the cart

## Optimum tuning of the PID controller for stable and unstable systems using nonlinear optimization technique

response and get a good response for the cart and then enhance the previous response of the angle.

The response of the angle and the cart resulted of PID tuning using the NCD block is shown in figures 5 and 6. It can be noticed from the figures how the PID controller return back the angle of the pendulum and the cart to their positions effectively.

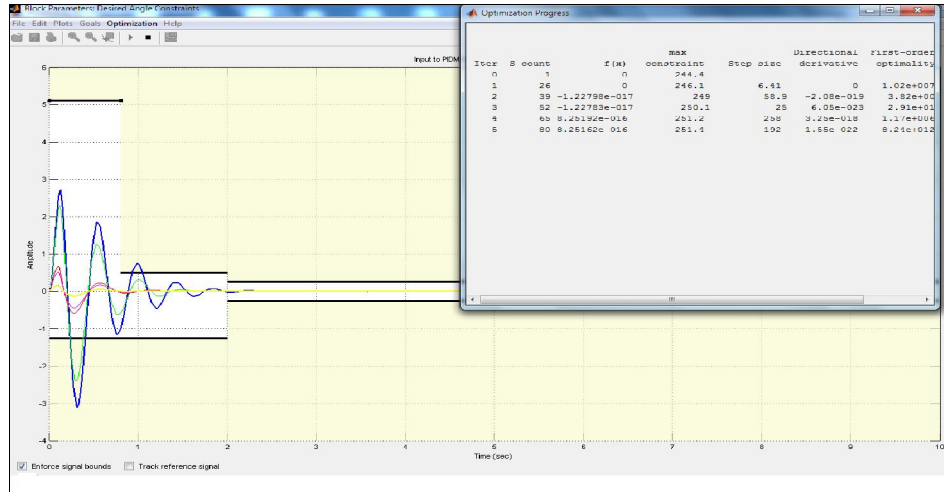

Figure(4) Tuning Process to desired response

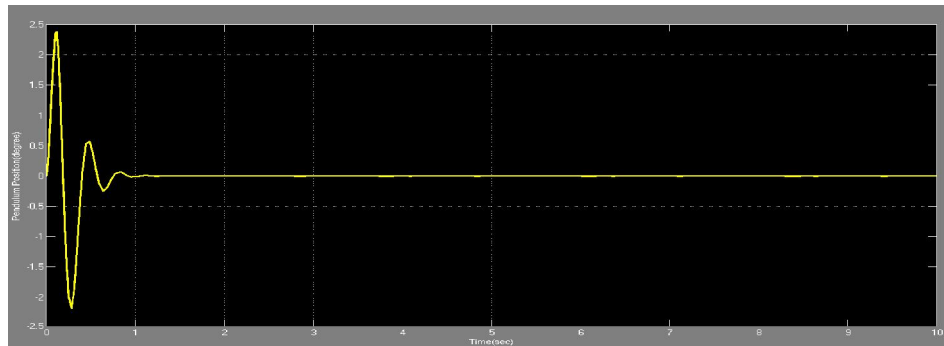

Figure(5): angle response of the pendulum

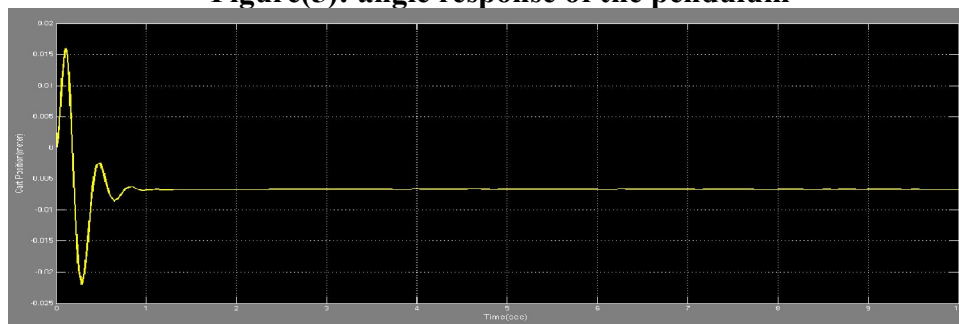

Figure(6): position response of the cart

## 5. Conclusion

Still Feedback is a very powerful idea and it desires a simple feature of control algorithm such as PID. The PID controller is widely applicable and easy to understand, involving as few tuning parameters as possible. All of the available PID tuning methods are only suitable for stable systems, and it is difficult to use these techniques for unstable systems. Here in our work we have proposed a tuning method based on SQP using the NCD block set in MatLab. The proposed tuning method is suitable and effective for tuning PID parameters; moreover, it increases the performance rate and improves the stability and error criterion of nonlinear unstable systems.

## 6. References

- [1] K. Astrom, T. Hagglund, "The future of PID control", *Control Engineering Practice*, V. 9, No. 11, (2001), pp. 1163-1175.
- [2] Dingyu Xue, Yang Quan Chen, and Derek P. Atherton, "Linear Feedback Control", the Society for Industrial and Applied Mathematics, 2007, ch. 6, pp. 183 – 235.
- [3] Adel A. AbdulRahman, Muhammad A. Al-yadoumi and Ali S. Abdulrazaq. "Control of non-linear system using conventional PID controller", *Proceedings of International Mechanical Engineering Conference (IMECE 2004)*, Kuwait, 5-8 December 2004.
- [4] Aidan O'Dwyer, John Ringwood, "A classification of techniques for the compensation of time delayed processes. Part 1 parameter optimised controllers", *Modern Applied Mathematical Techniques in Circuits, Systems and Control*, World Scientific and Engineering Society Press, ISBN: 960-8052-05-X, 1999, pp. 176 – 185.
- [5] J. G. Ziegler and N. B. Nichols, "Optimal setting for automatic controllers", *Trans. ASME*, vol. 64, pp.759 – 768. 1942.
- [6] ] K. Astrom, T. Hagglund, Revisiting the Ziegler-Nichols step response method for PID control, *Journal of Process Control* 14 (2004) 635-650.
- [7] A. Ali, S. Majhi, "PI/PID controller design based on IMC and percentage overshoot specification to controller setpoint change", *ISA Transactions* 48 (2009) 10-15.
- [8] J. C. Basilio and S. R. Matos, Design of PI and PID controllers with transient performance specification, *IEE. Transaction and Education*,



vol. 45, no. 4, November 2002.

- [9] S. Alcantara, W.D. Zhang, C. Pedret, R. Vilanova, S. Skogestad, “IMC-like analytical  $H_{\infty}$  design with S/SP mixed sensitivity consideration: Utility in PID tuning guidance”, *Journal of Process Control*, Vol. 21 (2011), pp. 976– 985.
- [10] Kafetzis, G., Patelis, P., Tripolitakis, E.J., Stavrakakis, G.S., Kolokotsa, D., Kalaitzakis, K., “PID controller tuning and implementation aspects for building thermal control”, *WSEAS Transactions Vol. 5, No. 7*, pp. 1016–1020, 2006.
- [11] Valério, D., and da Costa, J. S., “Tuning-Rules for Fractional PID Controllers,” *Proceedings of the Second IFAC Symposium on Fractional Differentiation and Its Applications (FDA06)*, IFAC, 2006.
- [12] Tripti Bhaskaran, Yang Quan Chen, Dingyu. Xue, “Practical tuning of fractional order proportional and integral controller (I)”, *Proceedings of DETC’07 ASME Design Engineering Technical Conferences September 4-7, 2007, Las Vegas, Nevada, USA*, pp. 1 – 13, 2007.
- [13] Luciola Campestrini, Pericles Rezende Barros, and Alexandre Sanfelice Bazanella, “Auto-Tuning of PID controllers for MIMO processes by Relay feedback”, *International Symposium on Advanced Control of Chemical Processes, Gramado, Brazil – April 2-5, 2006*, pp. 451 – 456, 2006.
- [13] Leandro Dos Santos Coelho and Antonio Augusto Rodrigues Coelho, “Automatic tuning of PID and gain scheduling PID controllers by a derandomized evolution strategy”, *AI EDAM*, Vol.13, pp. 341-349, 1999.
- [14] Mohammed Obaid Ali, S. P. Koh, K. H. Chong, S.K.Tiong and Zeyad Assi Obaid, “Genetic Algorithm Tuning Based PID Controller for Liquid-Level Tank System”, *Proceedings of the International Conference on Man-Machine Systems (ICOMMS)*, 11 – 13 October 2009, Batu Ferringhi, Penang, MALAYSIA, pp. 4A5-1 - 4A5-5, 2009.
- [15] Marco Antonio Paz-Ramos, Jose Torres-Jimenez, Enrique Quintero-Marmol- Marquez, “Proportional-Integral-Derivative Controllers Tuning for Unstable and Integral Processes Using Genetic Algorithms”, *International Conference on Computational Science*, pp. 532-539, 2004.
- [16] Subhransu Padhee, Abhinav Gautam, Yaduvir Singh, and Gagandeep Kaur, “A Novel Evolutionary Tuning Method for Fractional Order PID

- Controller”, International Journal of Soft Computing and Engineering (IJSCE), Vol. 1, Issue 3, pp. 1 – 9, 2011.
- [17] S.M.Girirajkumar Atal.A.Kumar, N.Anantharaman, “Tuning of a PID Controller for a Real Time Industrial Process using Particle Swarm Optimization”, , IJCA Special Issue on “Evolutionary Computation for Optimization Techniques” ECOT, 2010, pp. 35 – 40, 2010.
- [18] Mohammed El-Said El-Telbany, “Employing Particle Swarm Optimizer and Genetic Algorithms for Optimal Tuning of PID Controllers: A Comparative Study”, ICGST-ACSE Journal, Vol. 7, Issue 2, pp. 49 - 54, 2007.
- [19] B.Nagaraj, S.Subha ,B.Rampriya, Tuning Algorithms for PID Controller Using Soft Computing Techniques, IJCSNS International Journal of Computer Science and Network Security, Vol.8 No.4, pp. 278 – 281, April 2008.
- [20] Jie Bao, P.J.McLellan, and J. Fraser Forbes, “Tuning Method for Multi-loop PID Controllers using Semi-Definite Programming”, CHEMECA, Newcastle, Australia, September 26-29, 1999.
- [21] Tan, Y.-H., Dang, X.-J., & van Cauwenberghe, A., “Generalised nonlinear PID controller based on neural networks”, Proceedings of information, decision and control, pp. 519 – 524, 1999.
- [22] Junghui Chen, Tien-Chih Huang, “Applying neural networks to on-line updated PID controllers for nonlinear process control”, Journal of Process Control, Vol. 14, pp. 211–230, 2004.
- [23] Dotoli, M. and B. Turchiano, “ Fuzzy gain scheduling of coupled PID controllers for stabilization of the inverted pendulum”, In Proceedings of Eunite 2003 – European Symposium on Intelligent Technologies, Hybrid Systems and their implementation on Smart Adaptive Systems, July 10-11, 2003, Oulu, Finland, pp. 136-144, 2003.
- [24] Jan Jantzen, “Tuning of fuzzy PID controllers”, Denmark.Tech.. Report No 98- H 871(fpid), 30 Sep 1998, pp. 1-22, 1998.
- [25] M. P. Veeraiah S. Majhi Chitralekha Mahanta, “Fuzzy Proportional Integral - Proportional Derivative (PI-PD) Controller”, Proceeding of the 2004 American Control Conference, Boston, Massachusetts June 30 - July 2, 2004, pp. 4028 – 4033, 2004.