

E-Health Monitoring System Using NodeMCU

Basavaraj Shrishail*¹, Guruprasad Nellur², Shivaji Koli³

^{1, 2, 3} *Asst. Professor, Department of computer science, Lingaraj Appa Engg.College,
Bidar, Karnataka, India*

Corresponding Author

E-mail Id:- basavaraj8762@gmail.com

ABSTRACT

Internet of Things (IoT) is used to communicate two or more object or devices over the internet without interaction of the human. In the present days the IoT is becoming more and more popular because of its wide variety of uses in different domains such as home automation, smart city monitoring, Transport and logistics, Smart Environment, Health Care, Smart Agriculture, Medical field, Energy Management, Retails, Marketing field etc. In this paper focus is made on Health care Domain. Health Monitoring using Node-Microcontroller-Unit(MCU) is proposed to check the patient health condition dynamically without visiting the hospital. In proposed work many smart devices are used to collect the heart rate, body temperature, sugar level. from the human body. If any variance above or below normal threshold is found in human body such as heart rate, temperature and sugar level then this system will send a sms to his/her family doctor/hospital, it also shares the current location of the person as it is very useful for them to track the patient.

Keywords:-*IoT, LM35 sensor, Health Monitoring, Heart rate sensor, Node MCU, Ubidots.*

INTRODUCTION

In recent years IoT has emerged as a most popular technology, IoT is used to collect the sensor data and making use of this sensor data it allows control or monitor remotely across its current network infrastructure. Present days IoT is used in many applications such as home automation, smart city, agriculture, retailer shop smart environment collision detection system and in many other applications [1].

In this paper making use of smart devices or sensors to sense the current data like the heart rate sensor is used to sense the current heart rate of the human, The GPS is used for location tracking of the patient, The LM35 sensor is used to sense the current temperature of the body [2-5]. It will send the sms to hospital before it sending sms the patient must register any particular hospital. While registering

patient must give the full details about him/her. These parameters play a vital role in the transmission of the data over a network. The aim of this system is used to monitoring the human body continuously without any time any place without human interaction.

Section II deals with literature survey, Section III deals with Shivaji Koli algorithm description, Section IV discusses implementation,

LITERATURE SURVEY

In last few years, health care field has attracted wide attention from researchers to address the various practical challenges. Because of this now we have many health care related applications [7].

Working with Arduino board and Arduino tool is very easy and fast processing. Arduino tool is open source software, Arduino or NodeMCU board is low cost,

accurate data reading and highly reliable [3]. The heart rate sensor is used measure the pulse rate of heart. At each and every minute continuously using Arduino board. It based on the principle of Photo Phelthysmo Graphy (PPG) which is non-invasive method of measuring the variation in heart rate using a light source and detector [4].

Now a day in many applications the Global Positioning System (GPS) is used to find the accurate navigation. How GPS works in real world applications and importance of using GPS [5]. The temperature sensor is used with Arduino board to find the body temperature. Temperature sensor read the very accurate data. It is very easy to use [6].

SENSOR DESCRIPTION

NodeMCU

NodeMCU is an open source IoT stage. It incorporates firmware which keeps running on the ESP8266 Wi-Fi Systems, and equipment which depends on the ESP-12 module. NodeMCU began on 13 Oct 2014, when Hong submitted the primary document of nodemcu-firmware to GitHub. As Arduino.cc started growing

new MCU sheets in view of non-AVR processors like the ARM/SAM MCU and utilized as a part of the Arduino IDE, they expected to adjust the Arduino IDE with the goal that it would be moderately simple to change the IDE to help exchange instrument chains to permit Arduino C/C++ to be ordered down to these new processors.

They did this with the presentation of the Board Manager and the SAM Core. A "center" is the accumulation of programming segments required by the Board Manager and the Arduino IDE to order an Arduino C/C++ source scrape down to the objective MCU's machine dialect. Some inventive ESP8266 devotees have built up an Arduino center for the ESP8266 Wi-Fi that is accessible at the GitHub ESP8266 Core site page. This is what is prominently called the "ESP8266 Core for the Arduino IDE" and it has turned out to be one of the main programming advancement stages for the different ESP8266 based modules and improvement sheets, including NodeMCU. NodeMCU pin detail as shown in below Figure 1.

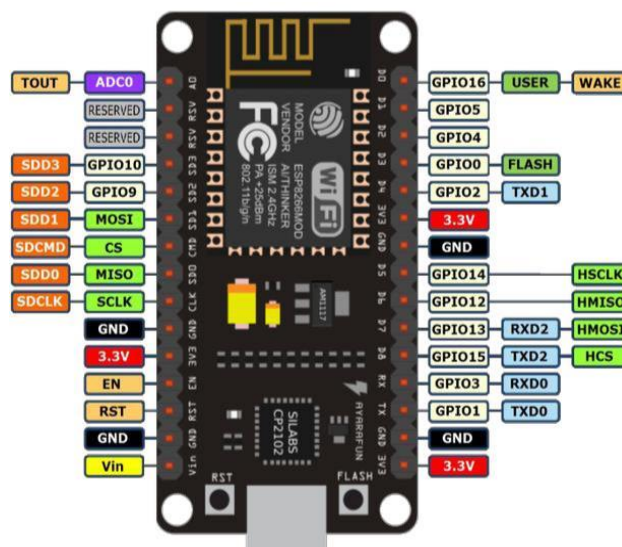

Fig.1:-NodeMCU

Temperature Sensor

Temperature is a standout amongst the most generally estimated factors and it is in this way not astounding that there are numerous methods for detecting it.

Temperature detecting should be possible either through direct contact with the warming source, or remotely, without coordinate contact with the source utilizing transmitted vitality.

There is a wide assortment of temperature sensors available today, including Thermocouples, Resistance Temperature Detectors (RTDs), Thermistors, Infrared, and Semiconductor Sensors.

Global Positioning System

The Global Positioning System (GPS) is a system of around 30 satellites circling the Earth at an elevation of 20,000 km. The framework was initially created by the US government for military route yet now anybody with a GPS gadget, be it a Satnav, cell phone or handheld GPS unit, can get the radio flags that the satellites communicate. Wherever you are on the planet, no less than four GPS satellites are 'obvious' whenever.

Every one transmits data about its position and the present time at customary interims. These signs, going at the speed of light, are captured by your GPS collector, which computes how far away each satellite depends on to what extent it took for the messages to arrive.

When it has data on how far away no less than three satellites are, your GPS recipient can pinpoint your area utilizing a procedure called trilateration.

Heart Rate Sensor

When it has data on how far away no less than three satellites are, your GPS

recipient can pinpoint your area utilizing a procedure called trilateration.

Further developed models offer estimations of heart rate inconstancy, movement, and breathing rate to survey parameters identifying with a subject's wellness. Sensor combination calculations enable these screens to recognize center temperature and drying out.

METHODOLOGY

In this paper we make use of many IoT devices these devices are heart rate sensor, LM35 temperature sensor, GPS device, NodeMCU-ESP8266. The heart rate sensor senses every minute heart beats and LM35 sensor sense the body temperature. The GPS is used for tracking the exact location of the patient. NodeMCU ESP8266 board Wi-Fi enabled device is used connect the sensor and to interact with the cloud.

In this we have two phases 1. Sensors Network

2. Transmission. The Sensor network is constructed to collect the required data from the patient. The parameters used to diagnose the disease vary from one disease to another disease. Therefore each separate sensor is used to connect the patient.

3. All sensor connected to body of patient is also called as Body Area Network (BAN) or Sensors Network. In transmission phase the data is collected from the individual sensors and transmitted to cloud database using the Wi-Fi device.

4. The mobile device is used for receiving the sms from the server when the variation in patient body is detected. Figure 2 shows overall working process of the system.

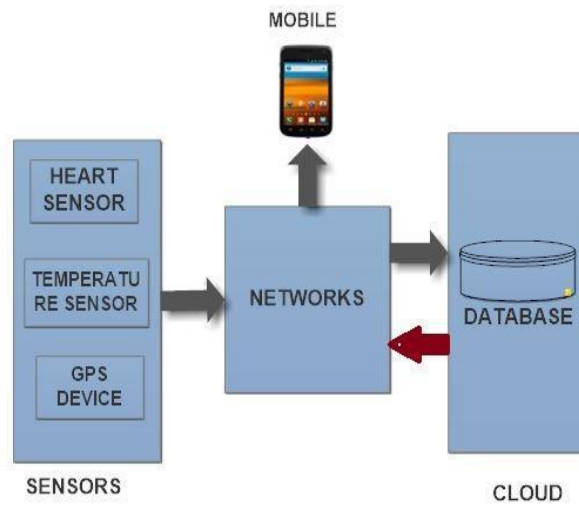

Fig.2:-Block Diagram

The flow of Health care monitoring system is shown in below Figure 3. The nodeMCU reads the data from the sensors and updates this data in cloud server. After updating the data it will check whether recently updated data is normal or abnormal by comparing the recently

updated data with fixed threshold values. If recently updated data is greater than or less than fixed threshold value then health condition is in abnormal state then it will send a sms to registered hospital number. If recently updated data is normal or threshold value then it will do nothing.

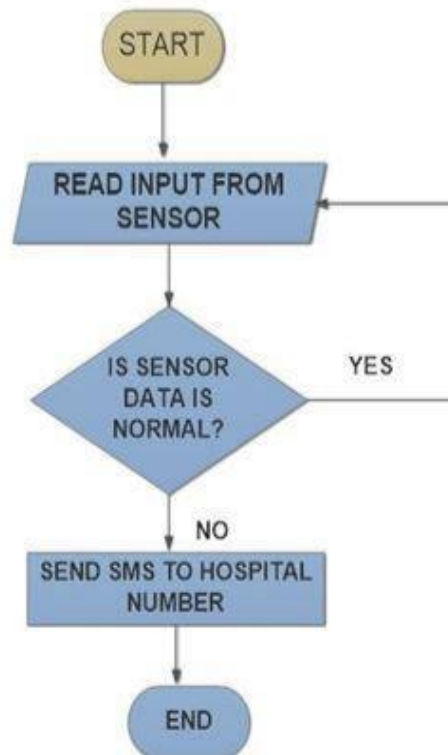

Fig.3:-Flow Char characteristics of IoT and Cloud enablement that digital transformation.

EXPECTED RESULTS

1. The IoT medicinal services organize must be able to help the versatility of patients with the end goal that they can be associated anyplace, whenever.
2. IoT-based social insurance benefits as an ease innovation.
3. Need not require the consistent checking in light of the fact that any variety is discovered it will consequently send a sms to specialist.

1. Ubidots

The Ubidots was established in 2012. It is open source software is used to store the data in cloud. This is specially used for storing the sensors data into cloud. Since Ubidots has established itself as the most cost-effective and user-friendly IoT platform in the face of fierce competition in the hardware, software, embedded engineering, reliable, and maker communities. Ubidots specialized in connected software and hardware solutions to remotely monitor, automate processes, control and updating in cloud data. Ubidots expanded our support industries and accomplished countless internet connected projects across – Healthcare, Energy Utilities, Transportation, and Retail – learning the many small

CONCLUSION

In this we presented a model for recognizing human activities patterns from smart devices. Occupants' habits and behavior follow a pattern that could be used in health applications to track the wellbeing of individuals living alone or those with self-limiting conditions. This will helps health applications to promptly take actions such as sending alert to patients or care providers.

REFERENCES

1. Li, S., Xu, L. D., & Zhao, S. (2015). The internet of things: a

survey. *Information systems frontiers*, 17, 243-259.

2. Islam, S. R., Kwak, D., Kabir, M. H., Hossain, M., & Kwak, K. S. (2015). The internet of things for health care: a comprehensive survey. *IEEE access*, 3, 678-708.

3. Louis, L. (2016). working principle of Arduino and u sing it. *International Journal of Control, Automation, Communication and Systems (IJCACS)*, 1(2), 21-29.

4. Mallick, B., & Patro, A. K. (2016). Heart rate monitoring system using finger tip through arduino and processing software. *International Journal of Science, Engineering and Technology Research (IJSETR)*, 5(1), 84-89.

5. Weerakoon, K. M. K., Rupasinghe, K. S., Withanaarachchi, T. P., Godaliyadda, G. M. R. I., & Ekanayake, M. P. B. (2017, December). Outdoor human navigation with gps and sensor systems. In *2017 IEEE International Conference on Industrial and Information Systems (ICIIS)* (pp. 1-6). IEEE.

6. Liu, C., Ren, W., Zhang, B., & Lv, C. (2011, August). The application of soil temperature measurement by LM35 temperature sensors. In *Proceedings of 2011 International Conference on Electronic & Mechanical Engineering and Information Technology* (Vol. 4, pp. 1825-1828). IEEE..

7. Yassine, A., Singh, S., & Alamri, A. (2017). Mining human activity patterns from smart home big data for health care applications. *IEEE Access*, 5, 13131-13141.