



A meta-analysis of LCAs for environmental assessment of a conceptual system: Phosphorus recovery from dairy wastewater

Marta Behjat^{*}, Magdalena Svanström, Gregory Peters

Division of Environmental Systems Analysis, Department of Technology Management and Economics, Chalmers University of Technology, Gothenburg, SE412 96, Sweden

ARTICLE INFO

Handling editor: Mingzhou Jin

Keywords:

Phosphorus recovery
LCA
Dairy wastewater
Wastewater treatment
Environmental impact
Meta-analysis

ABSTRACT

A significant increase in phosphorus-rich dairy wastewater coincides with a decrease in the availability of fossil phosphate rock resources in Europe. This confluence of events has led to the development of technologies for phosphorus recovery from dairy wastewater. This study aims to inform and guide such development with regard to life cycle environmental impacts prior to their implementation in dairy contexts. With the lack of inventory data at this point and the non-existence of earlier life cycle assessments on the use of phosphorus recovery technologies in a dairy context in literature, we performed a meta-analysis where we extracted and compared published results on life cycle environmental impacts from two fields (1) dairy industries, with a focus on the dairy wastewater treatment and (2) phosphorus recovery technologies in a municipal wastewater treatment context. The results show that despite its intended effect, normal dairy wastewater treatment in many cases still contributes significantly to eutrophication. Most of the phosphorus recovery technologies examined here exhibited a lower global warming potential and cumulative energy demand than those of dairy wastewater treatment processes. It indicates that problem shifting could be avoided when phosphorus recovery is introduced. However, no technologies involving incineration have had the impact of acidification reported which represents a potential knowledge gap since impacts are expected related to incineration emissions. A comparison between the extracted data for phosphorus recovery technologies shows that there are lower impacts related to technologies that recover phosphorus from the liquid phase, than from sludge or ash.

1. Introduction

European food security is threatened by Europe's lack of phosphate reserves and by sources of phosphate rock being located in geopolitically sensitive regions (Schröder et al., 2010). Phosphate rock is a finite, non-renewable resource that is mostly used in fertiliser production. Fertiliser demand is expected to increase owing to a growing world population and consequent increase in demand for food. From 1983 to 2013, the global consumption of phosphate rock increased by 25% (Bradford-Hartke et al., 2015). The increasing demand for this finite resource led the European Commission to declare phosphate rock as a critical raw material in 2014, and phosphorus (P) as a critical element in 2017 (European Commission, 2017). Therefore, an alternative to using phosphate rock for fertiliser production is required.

To respond to this challenge, the European Union (EU) has prioritised the recovery and safe reuse of P from food and municipal waste flows through its circular economy package (European Commission, 2016). Therefore, interest in development of technologies with regard to

nutrient recovery from organic waste streams has increased in recent years. A potential input waste stream for these technologies is dairy wastewater (DWW).

According to the European Dairy Association (EDA), the dairy sector is the most economically important part of the European agri-food industry, and it is present in all EU member states. It provides nutrition to all generations of the European population and regular earnings to 300,000 employees in dairy companies as well as the connected 700,000 farmers producing raw milk (EDA, 2018). The total EU milk production is approximately 160 million tons (22% of the world's total milk production) (EDA, 2018). The EU is a major exporter of dairy products and the largest cheese and skimmed milk powder exporter in the world (EDA, 2018). The European milk quota system was introduced in 1984 to limit public expenditure on the sector, control milk production, and stabilise milk prices and the agricultural income of milk producers (European Commission, 2009). After the system was abolished in 2015, the dairy sector grew (Slavov, 2017) and higher DWW volumes now need to be treated to avoid environmental problems (Ashkuzzaman

^{*} Corresponding author.

E-mail address: marta.behjat@chalmers.se (M. Behjat).

et al., 2019). DWW is also a potential source (Yapıcıoğlu and Yeşilnacar, 2020) of P that could contribute to addressing the growing demand for fertilisers for food production. Because the dairy industry produces different products, the characteristics of DWW effluents also vary greatly, but the P concentration is typically higher in DWW than in municipal wastewater (Shilpi et al., 2018). The concentration of total P (TP) in DWW has been reported to vary from 8 to 280 mg/L (Demirel et al., 2005), and sludge produced from DWW treatment has been reported to have a content as high as 52 g TP/kg of sludge (Numviyimana et al., 2022).

To achieve the goal of P recovery in the dairy industry, the REFLOW European Training Network (ETN) has focused on developing and demonstrating processes for the recovery and use of P fertiliser products from DWW. The REFLOW ETN (January 2019–December 2022) has finances for 13 early stage researchers to investigate P recycling from dairy wastewater. The majority focus on technical aspects of P recovery, providing data to others that assess economic and environmental aspects.

The technical elements studied by REFLOW are: (i) accumulation, and crystallisation or mineralisation of P-rich products (struvite or phosphoric acid) from liquid effluents; (ii) drying or hydrothermal carbonisation of sludge; and (iii) extraction of heavy metal-free, water-soluble phosphate salts and phosphoric acid from ash from sludge incineration, in all cases to allow for the production of new fertilisers and enable more circular P flows through society. The work described in this study aims to explore the environmental challenges and opportunities associated with these types of P recovery from DWW.

A common method for assessing the environmental impacts of new technologies is life cycle assessment (LCA). LCAs have been used to assess the environmental impacts associated with dairy production and P recovery from different wastewaters, but no LCA study that combines the two has been reported. Furthermore, it is still too early to create an original LCA using data from the REFLOW ETN. Therefore, information from previous studies was extracted and compared in this study to identify potential environmental challenges and opportunities and thereby provide knowledge and guidance during early stages of technology development. To provide input to both technical development activities and to further environmental assessment efforts in the REFLOW ETN, the following two guiding questions were formulated: (1) Are the environmental impacts related to dairy wastewater treatment (DWWT) an important part of the environmental impact of dairies, and what are the hot spots and influencing factors? and (2) What are the environmental impacts related to P recovery technologies in comparison to those of DWWT, and what are the influencing factors?

Owing to a lack of published LCAs on P recovery from DWWTs, an innovative approach for extracting and recalculating literature results (here called meta-analysis) was employed to compare results from LCA studies of dairy products to results from LCA studies of P recovery technologies made for other contexts. Thus, a novel combination of information from earlier LCA studies was compiled and assembled to generate new information that is useful for understanding the impacts of a combined system that represents P recovery in a dairy context.

2. Materials and method

In this study, LCA results from two different industrial contexts were explored, extracted and compared: (1) the dairy industry, particularly its wastewater treatment, and (2) P recovery technologies (typically applied to municipal wastewater treatment), with the aim of understanding its application in the dairy industry. This required careful data extraction and recalculation of some information to allow for conclusions to be drawn regarding the environmental challenges and opportunities of a combined system. This section describes the methodology that was applied to shed light on the environmental impacts related to DWWT, P recovery technologies, and combined systems. Firstly, the technical context as defined by the needs of REFLOW is described. As no

LCA studies exist that focus on P recovery in a dairy context, LCA studies on dairy operations that include details on DWWT were explored in a first step and then LCA studies on P recovery. Finally, information from both were compared to provide an understanding for the challenges and opportunities of a combined system. For this comparison, assumptions based on additional quantitative information regarding both the P content in DWW and the efficiency of studied P recovery technologies had to be made to connect information from the two groups of LCA studies.

2.1. General description of the investigated system

Because of the intended focus on P recovery from the dairy industry in this study, the major interest was its current generation and treatment of DWW. The sizes of dairy processing plants and the types of manufactured products vary significantly between sites. Generally, dairy plants can be divided into different production sections, and each section produces wastewater (Costea and Ghinea, 2021). In terms of volume and composition, DWW depends on the type of products generated and specific processes used in the dairy industry (Brazzale et al., 2019). The treatment of DWW normally consists of three steps (see Fig. 1). The first process removes fats, oils, and grease through dissolved air flotation (DAF); the second is an anaerobic and/or aerobic treatment; and the third is focused on the removal of nutrients through chemical or biological treatment (Ashkuzzaman et al., 2019; Brazzale et al., 2019).

P recovery from dairy wastewater is innovative, and no LCA currently exists that describes the environmental impacts of such a system, but comparable contexts can be found in municipal wastewater treatment plants. There are many different possibilities for nutrient recovery from wastewater (reviewed, e.g., in Harder et al. (2019)), and an increasing number of recovery processes have been implemented specifically for P recovery (an overview is provided in Egle et al., 2015). P recovery can be performed either from the liquid phase, sludge, or ashes generated from the incineration of sludge (please see chapter 2 of the supplementary material (SM) for further details on the P recovery technologies). The main P-containing product recovered from the liquid phase is struvite (magnesium ammonium phosphate). In these processes, after sludge thickening and dewatering, the liquid phase is subjected to crystallisation or precipitation, which is controlled by a combination of precipitation agents ($\text{Cl}_2\text{H}_{12}\text{MgO}_6$ and NaOH) and pH control (Linderholm et al., 2012). With regard to recovery from sludge, in municipal wastewater treatment contexts, it is common to first digest sludge for stabilisation and biogas production. For digested sludge, various P recovery approaches have been developed, ranging from direct application on agricultural land to recovery from sludge, such as wet chemical approaches (Egle et al., 2015). The recovery of P from ash after incineration can be achieved through wet chemical, thermo-chemical, or thermo-electric approaches (Egle et al., 2015). Each technology has a different P recovery potential which depends on both the technology employed and its initial source. Fig. 1 shows a conceptual system with P recovery from DWW, showing optional P recovery routes implemented in the context of DWWT.

2.2. Compiling earlier studies

The literature review for various parts of the study was completed in May 2021 using Scopus and Web of Science services. Documents were extracted based on the title, keywords, and abstracts. Relevant publications from any prior point in time were searched, and no filter for the year of publication was employed. Search terms are provided in the SM section 1. Studies which focused only on raw milk production on the farm in the assessment were excluded after an initial review. Studies that focused on the cleaning in place (CIP) process were also excluded. The CIP process is a procedure that allows the cleaning and sanitisation of dairy equipment without disassembling it or disconnecting the pipes (Gabrić et al., 2016). Wastewater from CIP is very low in nutrients, so it

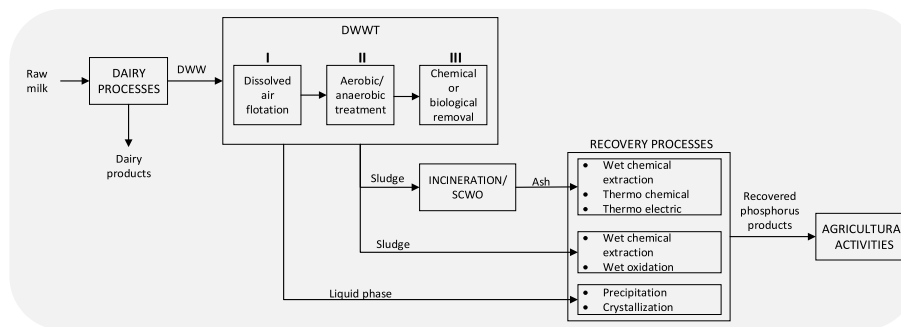

Fig. 1. Representation of a possible system with recovery of phosphorus from dairy wastewater, showing the optional recovery from liquid, sludge, or ash; a few example technologies are listed. DWW = Dairy wastewater. DWWT = Dairy wastewater treatment. SCWO = Super critical water oxidation.

was not the type of flow considered in REFLOW, and wastewater treatment was also not assessed in these studies. For P recovery, studies were included only if they focused on technologies employed to recover P (and sometimes also other nutrients), but not if they focused only on the removal of nutrients and/or reuse of the ‘cleaned’ water. Furthermore, REFLOW does not consider the direct application of sludge or ash in the field; therefore, such studies were excluded. Some EU member states are hesitant to allow the application of sludge directly on land because of concerns regarding the possible presence of heavy metals, pathogens, pharmaceuticals, and complex organic compounds that can contaminate soil. P in ash is also insoluble in water and has low plant availability (Egle et al., 2015). After the first literature screening and initial sorting, 25 studies remained that dealt with LCA of dairy industries (23 LCAs of dairy product manufacturing and two LCAs of DWWT), and nine studies dealt with LCA of P recovery technologies.

Since the review of LCAs of dairy activities aimed primarily at revealing the potential environmental impacts of DWWT, a second sorting revealed that only 17 of the 23 articles on the dairy industry actually included DWWT in the system boundary, and only nine of those presented life cycle impact assessment (LCIA) results for DWWT explicitly (see Fig. 2). Regarding LCA studies on P recovery technologies, only six of the nine articles allowed for the extraction of environmental impact data for the recovery process only (see Fig. 2).

In addition, to allow for the integration of the two sets of studies into an understanding of impacts for the combined system described in Fig. 1, one paper with an overview and description of technologies for recovering P and seven on the chemical characteristics of dairy industry wastewater were consulted (see Fig. 2).

Since the purpose of this study was specifically to model systems not currently in operation, we had to be particularly selective regarding the available literature. Few studies report sufficiently disaggregated data of the right kind on the right topics. Nevertheless, with the literature that survived our review criteria we were able to cover a wide range of dairy processing and P-recovery systems.

2.3. Meta-analysis (collecting, recalculating, and assembling)

When extracting environmental impact results from published LCA studies, it must be remembered that the results are not directly comparable due to differences in functional units (FUs), environmental impact categories, system boundaries, and type of inventory data used. Therefore, the specifics of each included study must be carefully considered. A process similar to that suggested by Hermansson et al. (2019), called a meta-analysis of LCAs, was followed.

First, data from different studies were extracted and restructured. Fig. 3 shows the system parts that we wanted to extract information for from what was generally the full scope of the reviewed studies. To answer the first research question, impacts related to the dairy processes but separated for DWWT (gate-to-gate in the upper part of Fig. 3) and other parts were needed; in order to answer the second research question, impacts related to P-recovery processes as such (gate-to-gate in the lower part of Fig. 3) were needed. Incineration (and in one case, supercritical water oxidation) was considered part of the P recovery gate-to-gate system, when possible, as it was expected to bring a considerable environmental impact if installed for a DWW context; we point this out specifically, as this part was excluded in some LCA studies in the

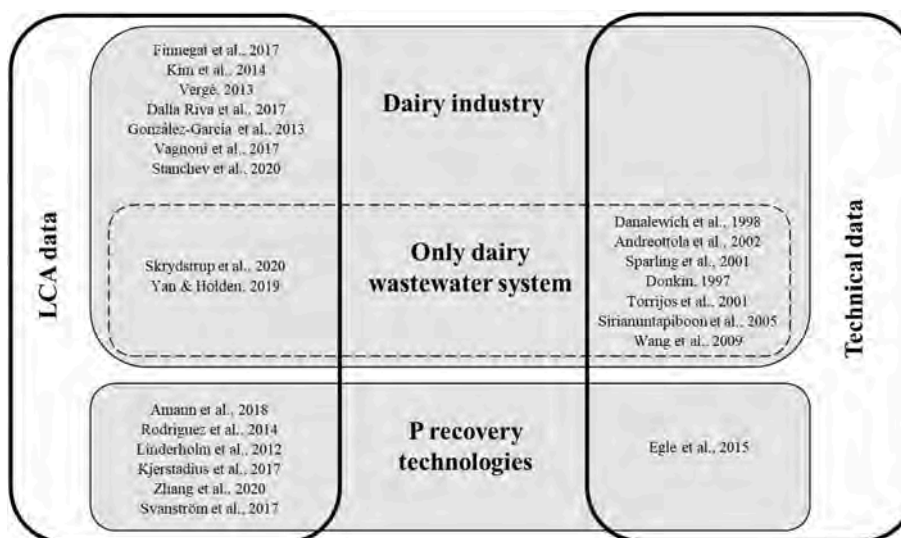

Fig. 2. Diagram illustrating the number and type of articles ultimately selected and reviewed for this paper.

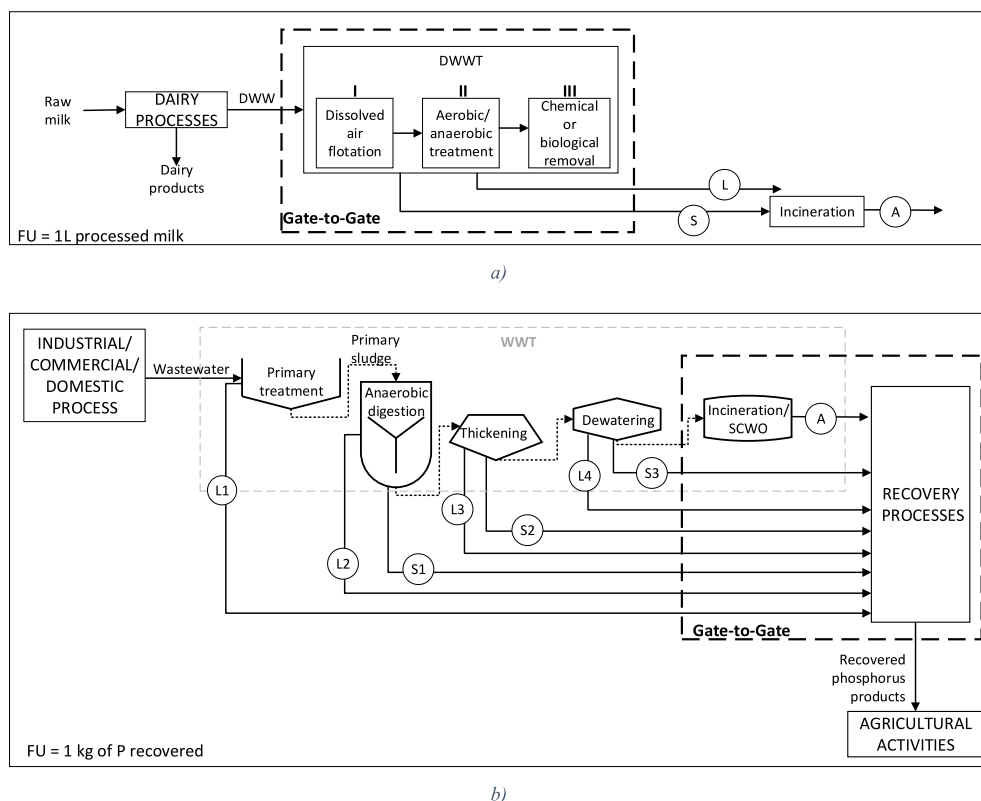

Fig. 3. System boundaries for the reviewed studies and for the system parts that were extracted for the comparison in the present study marked with bold dashed boxes for (a) the dairy wastewater treatment (DWWT) and (b) the P recovery process. A comparison was also made between the DWWT and the rest of the dairy process in (a). DWW = dairy wastewater; FU = functional unit; WWT = wastewater treatment. The letters represent liquid flow (L), sludge (S), and ash (A) obtained from different processes of the WWT and used in the recovery processes; the numbers added in (b) show the different extraction points considered in the reviewed studies and are referred to in Table 2.

literature. For other technologies, all the unit processes that would bring a considerable environmental impact if they were installed for DWW had been included. Data related to dairy farms, retailing, use and disposal of final products, municipal wastewater treatment, and any by-product system expansion were carefully removed. Nevertheless, some potentially important gaps and overlaps were present, which may have influenced the comparison. More specifically, neither of the technologies described by Amann et al. (2018) included the incineration operation and the struvite crystallisation process described by Zhang et al. (2020) included anaerobic digestion (AD) at the municipal wastewater treatment (WWT) plant.

Second, the information on environmental impacts was rescaled to the same FU. In LCAs on dairy products, it is common and recommended by the International Dairy Federation (IDF) (FIL-IDF, 2015) to use an FU of 1 kg of product. However, since the present study intended to find the total impact from dairy operations, as well as the share related to DWWT, in the first step, impacts were instead related to 1 L of processed milk (see the upper system in Fig. 3). One option could have been to relate the impacts directly to the flow of a unit of DWW, as it would be more relevant for the combined system later on, but as the amount of DWW per kg of product and per L of processed milk varies depending on specific practices that are not in focus in our study, we found it more relevant to base the first part of the analysis on the input of milk (FU = 1 L of processed milk).

According to the literature on LCA of P recovery technologies, 1 kg of P recovered is a common FU (see the lower part of Fig. 3). Together with the fact that this study is intended to be used in the development of P recovery technologies in a dairy context, 1 kg of recovered P was therefore used as a FU in the final compilation of the results of this study. To answer the second research question, the impact of the DWWT as gathered from the dairy LCAs was recalculated to relate to the P in the DWW. For this, further data were collected and analysed. These were the typical DWW volumes (scaled to 1 L of processed milk, collected from the LCAs in the dairy industry; see Table 13 in the SM) and the typical P concentration of DWW (from seven studies on DWW characteristics; see

Table 14 in the SM). As the published LCA studies lacked sufficient detail to allow for targeted selection, the average value of the P concentration in DWW was calculated after exclusion of extreme values (10 mg/L, and 640 mg/L); the average of the 20 remaining values was 67 mg/L. Also, we did not want the results to be scaled for a particular situation but for an average situation.

Finally, to relate the extracted and rescaled environmental impact results of the DWWT process to those of the P recovery process in a conceptual combined system (as represented in Fig. 1), further data on the efficiency of different P recovery technologies were collected and analysed (from the overview by Egle et al. (2015)).

By setting the concentration of P in the DWW to an average number the P flow in the DWW for the dairy LCA studies could be calculated (see Table 16 in the SM) and knowing the P recovery potential for different types of technologies made it possible to calculate the typical DWW volume needed for recovery of 1 kg of P (see SM section 4 for further details about the calculations). Finally, it was possible to relate the environmental impact of the DWWT to the environmental impact of P recovery for the same flow of P.

When evaluating the available information in the reviewed LCA studies, it was observed that only a few environmental impact categories were common to several studies and could be used in the final comparative work: cumulative energy demand (CED), climate impact based on global warming potential (GWP), and acidification based on acidification potential (AP). It would have been interesting to look into more categories, but these are the only ones that the available material allows.

3. Results and discussion

3.1. Dairy industry process

Table 1 presents a selection of LCIA results from the nine studies that eventually provided recalculated LCA results for dairy products (seven LCAs of dairy product manufacturing and two LCAs of DWWT), scaled to

Table 1

LCIA data for only the dairy wastewater treatment (DWWT) process, extracted from earlier LCAs and recalculated. These data are here scaled to the FU of 1 L of processed milk. The second column shows which of the dairy factories assessed in the LCA studies includes the DWWT on-site. The reported percentage values represent the contribution of the dairy wastewater treatment to the impact of the whole dairy. The environmental impact categories shown are climate impact based on global warming potential (GWP), cumulative energy demand (CED), eutrophication impact based on either freshwater eutrophication potential (FEP), marine eutrophication potential (MEP), or eutrophication potential (EP), acidification impact based on acidification potential (AP), and water depletion (WD) with units as provided in the first row of the table. Note that methods from several different LCIA frameworks are represented here (see SM section 7). The last two studies focused only on the DWW management. More details for all studies are found in the SM, e.g. section 3.1.

Studies	DWWT on-site	Products	GWP (kg CO ₂ eq)		CED (MJ)		FEP (kg P eq)		MEP (kg N eq)		EP (kg PO ₄ ⁻³ eq)		AP (kg SO ₂ eq)		WD (m ³)
González-García et al. (2013)		San Simon	2.73	16%	2.55	11%					5.45	75%	1.82	17%	
			× 10 ⁻²		× 10 ⁻¹						× 10 ⁻⁴		× 10 ⁻⁴		
Kim et al. (2013)	✓	Cheddar	6.09	4%	4.36	2%	7.27	61%	1.85	96%					7.92
			× 10 ⁻³		× 10 ⁻²		× 10 ⁻⁵		× 10 ⁻³						× 10 ⁻⁵
		Mozzarella	8.28	3%	4.97	2%	9.98	48%	2.09	95%					1.81
			× 10 ⁻³		× 10 ⁻²		× 10 ⁻⁵		× 10 ⁻³						× 10 ⁻⁴
Dalla-Riva et al. (2017)	✓	Mozzarella	9.55	1%	8.35	1%	1.59	18%	4.65	23%			6.31	4%	1.14
			× 10 ⁻⁴		× 10 ⁻³		× 10 ⁻⁶		× 10 ⁻⁵				× 10 ⁻⁶		× 10 ⁻³
Vagnoni et al. (2017)		Pecorino									3.02	1%			
											× 10 ⁻³				
Finnegan et al. (2017)	✓	Butter	5.71	6%	5.42	7%	1.70	16%	9.62	62%			2.34	10%	1.57
			× 10 ⁻³		× 10 ⁻²		× 10 ⁻⁶		× 10 ⁻⁶				× 10 ⁻⁵		× 10 ⁻²
		Milk Powder	6.88	3%	6.73	3%	1.80	13%	1.20	48%			3.62	5%	1.72
			× 10 ⁻³		× 10 ⁻²		× 10 ⁻⁶		× 10 ⁻⁵				× 10 ⁻⁵		× 10 ⁻²
Vergé et al. (2013)		Fluid Milk	8.21	2%											
			× 10 ⁻⁴												
		Yoghurt	1.70	1%											
			× 10 ⁻³												
Stanchev et al. (2020)		–	8.36	8%			1.54	6%							1.84
			× 10 ⁻³				× 10 ⁻³								× 10 ⁻⁴
Skrydstrup et al. (2020)		–	3.03	^a	4.56	^a									
			× 10 ⁻³		× 10 ⁻³										
Yan and Holden (2019)	✓	Butter A									9.43	^a			
											× 10 ⁻⁴				
		Butter B									5.21	^a			
											× 10 ⁻⁴				

^a The share of the total could not be calculated because the total was missing.

the FU of 1 L of processed milk. Different LCIA frameworks are represented depending on the choices made in the individual studies; in particular, different types of methods for assessing eutrophication impact were employed (see SM section 7).

As can be seen from Table 1, the LCIA results for DWWT vary greatly between studies, but mostly within one to two orders of magnitude, depending on the impact category. The percentage numbers provided in Table 1 show the share of the total environmental impacts of dairy operations that the WWT processes make up. Clearly, DWWT in many cases makes up a significant part of the dairy industry's environmental impact, but the range is large: from 1 to 96% for different studies, dairy products, and impact categories. The results show that the DWWT (which includes the impact of the release of the treated water) contributes particularly to the eutrophication impacts of the dairies, but also to water depletion (WD); between different studies, the largest variation in the DWWT share is for the eutrophication impacts. Emissions associated with DWWT contribute approximately 6–62% and 23–96% to the total freshwater and total marine eutrophication impacts, respectively. For the three indicators that are used in the comparison to the impact of P recovery technologies in the next section of this paper (CED, climate impact, and acidification), the DWWT's contribution to the overall

impact on dairy production is never larger than 17% in the analysed studies (please to see section 3.1 of the SM for more details on the calculations).

It must be remembered that the main point of performing DWWT is generally to reduce (or fulfil legal obligations aimed at limiting) the eutrophication impact. Even with DWWT, this impact is still important according to the reviewed studies, and it is dominated by the discharge of nutrients in the effluents and influenced by various processes in the dairy industry. The nutrients in wastewater originate from losses of both raw milk and dairy products (Dalla-Riva et al., 2017), but also from detergents used in the cleaning process (Eide, 2002). Another important factor which influences the eutrophication impact is dairy size (Stanchev et al., 2020). DWW can be transported to a WWT plant in a local municipality or treated on-site. On-site DWWT plants, which seem to contribute considerably to freshwater and marine eutrophication, as reported in more than one study (Dalla-Riva et al., 2017; Kim et al., 2013; Yan and Holden, 2019), are typical of small-scale mills. This type of mill typically does not produce a volume of whey that makes it profitable to install specific equipment for whey processing for secondary purposes, such as protein powder production. Therefore, the whey stream produced is often mixed with DWW effluent, increasing the

Table 2

Overview of P recovery technologies considered in the selected LCA studies, and the short names used in this paper (T1-22). P is recovered from three different source flows listed in the second column; see Fig. 3 for their origin in the WWT. Typical P concentrations in the considered flows are shown with the estimated P yield (recovery potential) as provided in Egle et al. (2015). The recovery potential is relative to the content in the original wastewater. The studies highlighted in grey are those which have an overlap (dark grey) or a gap (lighter grey) in the environmental impact data with regard to the gate-to-gate boundaries shown in Fig. 3b. The table also reports the P product and its common name in parenthesis. AD = Anaerobic digestion process; SCP = Struvite Crystallisation Process; WAO = Wet air oxidation; SCWO = Super critical water oxidation; TS = total solids.

Name in reviewed study (reference)	Source flow	P concentration (in the source flow in the reviewed study)	Recovery method(s)	Obtained product	P recovery potential (Egle et al., 2015)
T1 REM-NUT (Amann et al., 2018)	L1	~ 5 - 10 mg PO ₄ -P/L	Ion-exchange; Precipitation	Magnesium ammonium phosphate (Struvite)	~ 50% - 70%
T2 AirPrex® (Amann et al., 2018)	L2				~ 10% - 15%
T3 P-RoC (Amann et al., 2018)	L3 - L4				Crystallization
T4 Ostara Pearl® (Amann et al., 2018)					
T5 Ostara Pearl® (Linderholm et al., 2012)	L2	Dissolved part: 20 - 400 mg PO ₄ -P/L	Precipitation	Magnesium ammonium phosphate (Struvite)	~ 10% - 15%
T6 Struvite precipitation (Kjerstadius et al., 2017)					
T7 Crystallization (Zhang et al., 2020)					
T8 SCP (Rodriguez-Garcia et al., 2014)	S2		AD + Crystallization	40%*	
T9 Wet chemical - Stuttgart (Amann et al., 2018)			Crystallization	35%*	
T10 Wet chemical - Gifhorn (Amann et al., 2018)	S3 - S4	~ 1.4 g P/kg of sludge	Wet chemical extraction	~ 45%	
T11 PHOXNAN (Amann et al., 2018)			Wet chemical extraction + WAO	~ 50%	
T12 Aqua Reci® (Amann et al., 2018)	A	~ 50 - 130 g P/kg TS	SCWO + Precipitation	Calcium phosphate	~ 70%
T13 ICL Fertilizers® (Amann et al., 2018)			Wet chemical extraction (with H ₂ SO ₄)	Single super phosphate (SSP)	~ 85%
T14 RecoPhos® (Amann et al., 2018)			Wet chemical extraction (with H ₃ PO ₄)	Triple super phosphate (TSP)	
T15 EcoPhos® (Amann et al., 2018)			Acid wet chemical leaching (Multi modular decontamination)	Phosphoric acid	~ 80%
T16 PASCH (Amann et al., 2018)			Acid wet chemical leaching (solvent extraction)	Calcium phosphate	~ 70%
T17 LEACHPHOS® (Amann et al., 2018)			Acid wet chemical leaching	Calcium phosphate	~ 60 - 70%
T18 Ash Dec® (Cold Ash) (Amann et al., 2018)			Thermo-chemical	Depolluted ash	~ 85%
T19 Ash Dec® (Hot Ash) (Amann et al., 2018)					
T20 Ash Dec® (Linderholm et al., 2012)			Incineration + Thermo-chemical	Tetra phosphorus	~ 83%
T21 Ash Dec® (Svanström et al., 2017)					
T22 Thermphos® (Amann et al., 2018)	Thermo-electric				

*These sources were extracted from LCA studies (Zhang et al. (2020); Rodriguez-Garcia et al. (2014)).

nutrient concentration in the flow sent to an on-site treatment plant (González-García et al., 2013). Furthermore, P emissions contribute to a higher eutrophication impact due to the digestion of wastewater from whey processing (Kim et al., 2013). On-site treatment demands additional energy for the WWT plant, and energy production therefore also contributes indirectly to increases in different environmental impacts in those cases (Yan and Holden, 2019).

In a study by Stanchev et al. (2020), in addition to requiring a large share of electricity (approximately 48% of electricity used in dairy industry), DWWT contributed strongly to WD (approximately 64%) because of the production process for flocculants (in the specific case: calcium carbonate and sodium hydroxide).

The “yellow” products, such as cheese and butter, typically use more milk input per kg of product and therefore also produce a higher volume of DWW from the milk itself per kg of product compared to the “white” products, like fluid milk and yoghurt (European Commission, 2006, 2019). As Djekic et al. (2014) point out, this often leads to a higher impact per kilogram for yellow products than for white products. However, as the results are shown per litre of milk input in the present article, this effect cannot be seen here.

The fact that the eutrophication impact of the dairy is dominated by the content in the effluent, even as DWWT is present, reflects the fact that the treated DWW is still rich in nutrients which can possibly be recovered through the application of a recovery system. This could lead to a further reduction in the eutrophication impact and simultaneously generate valuable resources (although, the release of nutrients might primarily be governed by discharge permits). This makes it interesting to look at how large an impact that a typical P recovery process would bring, which would either be added to or would partially replace the impact from DWWT in a combined system. However, this comparison can, in this study, only be made for impact categories other than eutrophication for reasons described earlier.

3.2. Comparison between P recovery technologies and DWWT

The second part of this study focused on the environmental impacts of P recovery technologies and the factors that influence them. The environmental impacts were also compared with those of DWWT. This information reveals if there would be large environmental challenges related to adding P recovery to existing DWWTs and it may shed light on what needs to be considered in the development and implementation process.

Table 2 presents a brief technical description of the P-recovery technologies considered in the selected LCA studies. P recovery was done in municipal WWT contexts, which is different from the dairy contexts in focus in this study. The technologies were thus applied to flows that differed in terms of P concentration and physicochemical characteristics (see Fig. 3b for the origin of the source flows) and had different P recovery potentials and generated different types of P products.

Fig. 4 shows the LCIA results related to the P recovery technologies for 1 kg of P recovered (top line in each chart) and compares them to the DWWT (all other lines in each chart) for the three environmental impact categories that allowed cross-comparisons between the two sets of LCA studies: CED, climate impact, and acidification. The same marker is used for all technologies with the same P recovery potential and may, therefore, appear more than once in the first line. The impact of an eventual P recovery process implemented in a dairy context can be estimated as the sum of two values: the value for the P recovery in the uppermost line and the value for the same marker in any of the other lines. However, it is likely that in a real case, either the DWWT or the P recovery needs to be modified in a combined process which may lead to lower or higher impacts than this sum.

In general, looking at the P recovery in all three charts in Fig. 4, it seems that gaps and overlaps in gate-to-gate system boundaries vis-à-vis the WWT gate-to-gate may influence the results (technologies marked with grey cells in Table 2). Most technologies which recover P from ash

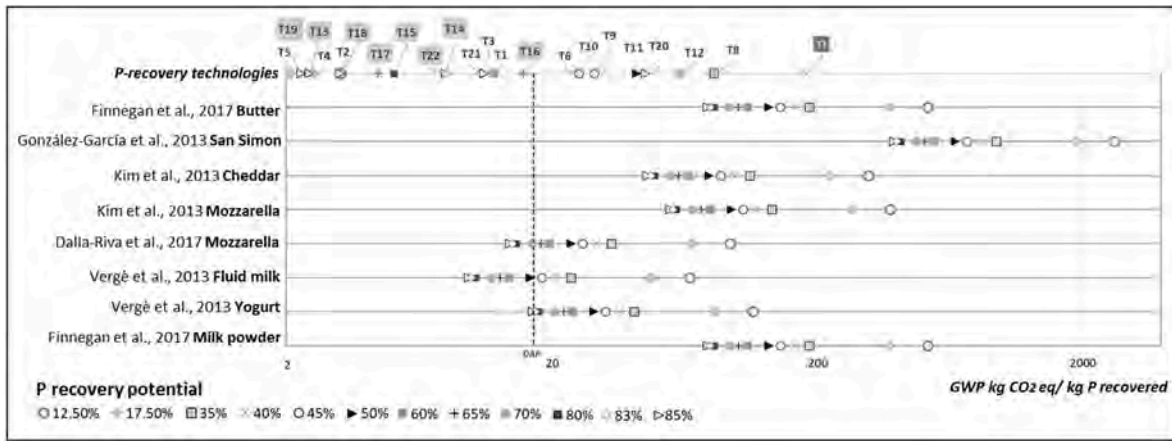

Fig. 4a. Climate impact as global warming potential (GWP), for P recovery (top line for each chart) and for DWWT for 1 kg of recovered P (all other lines). For the dairy LCAs, the different markers for each study and product represent different P recovery rates (one marker represents several P recovery technologies if the recovery rates are the same). The dark dashed line (4a) represents the climate impact per kg of P in DAP (Zhang et al., 2017). Note the logarithmic scale.

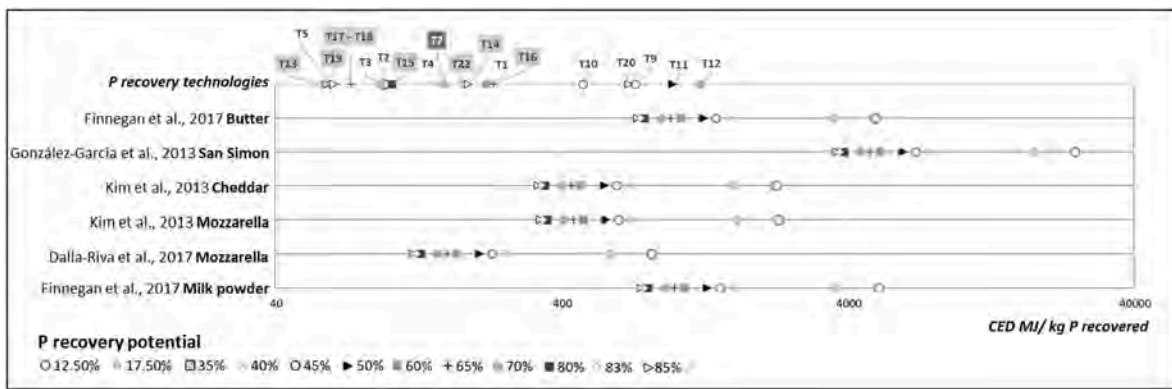

Fig. 4b. Energy use as cumulative energy demand (CED) for P recovery (top line for each chart) and for DWWT for 1 kg of recovered P (all other lines). For the dairy LCAs, the different markers for each study and product represent different P recovery rates (one marker represents several P recovery technologies if the recovery rates are the same). Note the logarithmic scale.

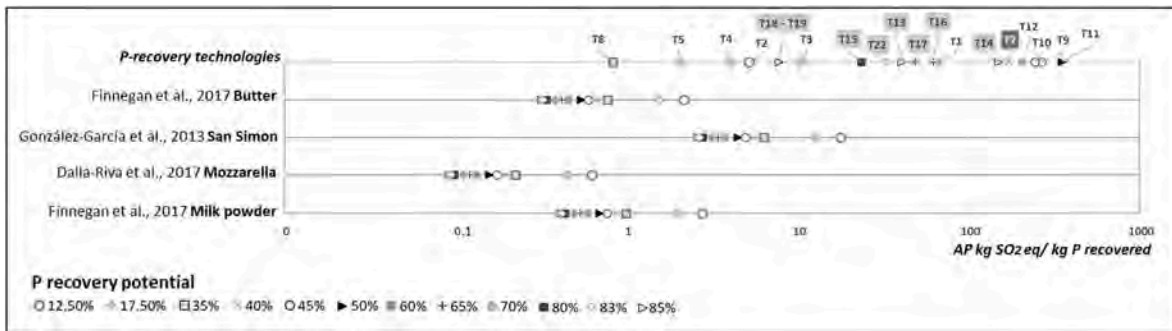

Fig. 4c. Acidification impact as acidification potential (AP) for P recovery (top line for each chart) and for DWWT for 1 kg of recovered P (all other lines). For the dairy LCAs, the different markers for each study and product represent different P recovery rates (one marker represents several P recovery technologies if the recovery rates are the same). Note the logarithmic scale.

have a lower impact because the incineration process was not included (T13–19 and T22). Indeed, among the technologies in the Amann et al. (2018) study, which does not include impacts from the incineration process in the LCA, all the technologies which recover P from sludge have a higher impact than those that start with ash. Linderholm et al.

(2012) and Svanström et al. (2017), on the other hand, found that technologies recovering P from ash (T20–21) have the highest impacts when incineration is included. The technology that includes AD and therefore represents a larger system is not surprisingly among the highest (T7), but it has to be remembered that system expansions have

been removed from these results so that any potential gains from gas or energy products from anaerobic digestion or incineration are not considered. It should also be mentioned that the system boundary for product use is not completely consistent. Some of the products need more processing before they can be used as fertilisers, and some are more or less ready for use. In particular, the RecoPhos® technology (T14) adds phosphoric acid to increase the P concentration, while the AshDec® technology (T18–21) generates a depolluted ash that will be sent for fertiliser production. These differences in system boundaries considered, a comparison between the extracted results for different P recovery technologies generally shows that lower impacts are demonstrated by technologies that recover P from the liquid effluent or start with an ash if the incineration is not included in the assessment. Those that start from ash and where incineration was included are instead grouped with technologies that recover P from sludge at the higher end.

Going into more detail on hot spots and influencing factors, most of the methods that recover P from the liquid phase (T1–8) have a low contribution to CED owing to a low demand of energy and input chemicals. The effect of the recovery of P from the liquid is the reduced demand for flocculating agents otherwise needed for sufficient P removal during wastewater treatment (Amann et al., 2018); which needs to be considered if this type of P recovery is considered for an existing site. In the case of P recovery from sludge solids (T9–12), the CED is primarily due to energy and chemical demands. For example, the wet chemical extraction reported by Amann et al. (2018) requires citric acid, sodium hydroxide, and sulfuric acid, which are energy-intensive in their production. In the case of the acid wet chemical and wet oxidation processes of T11 (PHOXNAN technology), a higher CED is related to its demand for oxygen and electricity, and to the disposal and treatment of the remaining solids and heavy metal slag. For T7, the P recovery technology assessed by Zhang et al. (2020), its CED is particularly high because it includes the AD which we consider is a potential overlap with a wastewater treatment process. In the case of T14, phosphoric acid was added to ash with a P content of 8.5% (Egle et al., 2015) to make a commercial product. This influences the CED and puts RecoPhos® technology among those with a higher impact than those that did not include incineration.

With regard to climate impact, this impact often correlates with CED. A few additional points raised by the reviewed studies are provided here. For nutrient recovery from the liquid phase by struvite precipitation and ammonia stripping (T6), the climate impact was largely due to emissions related to the heat demanded by the ammonium stripper (Kjerstadius et al., 2017). For wet chemical leaching from sludge (T9 and T11), the greenhouse gas emissions are primarily related to the production of the chemicals used (citric acid, sodium hydroxide, and sulfuric acid) and the high demand for coke and natural gas used during sludge mineralisation (Amann et al., 2018). Technologies which recover P from ash require higher temperatures; therefore, more energy is required for these processes, which influences the climate impact (Linderholm et al., 2012). This last point is seen only for T20–21 in Fig. 4, as all other ash-related technologies shown exclude incineration.

Also, for the acidification, similar patterns are seen as for CED and climate impact. However, no technologies involving incineration have reported the impact of acidification. As will be further discussed later, this creates a potentially important knowledge gap, as the acidification impact is high in relation to that of DWWT and would likely be even higher if incineration is included. More studies should be conducted, and methods to reduce this impact related to P recovery should be explored. Technologies that recover P from the liquid phase are generally those with a lower acidification impact. Factors that have been reported to influence acidification impacts are electricity use and NH₄ emissions to air during stripping and struvite or calcium phosphate formation, which therefore require careful pH adjustment (Rodriguez-Garcia et al., 2014).

The results shown in Fig. 4 for the treatment of DWW were calculated for an unmodified DWWT and with the P recovery rates provided by Egle et al. (2015). It is not likely that the resulting impact when P recovery is

installed at an existing site would be exactly the sum of the impact of the P recovery and the impact of the DWWT, as some alterations would likely be made if P recovery was introduced in a dairy context or if P recovery technologies were adapted to fit the new source flow; however, this comparison reveals orders of magnitude and things to pay attention to. Comparing the impacts from DWWT to those for P recovery (by matching the same marker in the uppermost line to one in any other line in Fig. 4), it is clear that P recovery technologies generally have a lower CED, and climate impact and a higher acidification impact compared to DWWT. However, there are some exceptions, in particular, when the CED and climate impacts of DWWT were already low in relation to Table 1, which was discussed earlier, and when recovery technologies received a high impact from the use of chemicals, such as precipitants, and included incineration.

It should be noted that any benefits related to the ultimate use of recovered P products were removed in our study to allow for consistent system boundaries, and potential differences between products, for example, plant availability and method for application, are therefore not captured. It is recommended that a full life cycle study be made of a system that contains both relevant parts of the dairy, on- or off-site P recovery, and transport, spreading, and use of recovered P products, once data of sufficient quality are available. It should also be mentioned that the current study only considers operation of the plants. Impacts related to construction could be added in future studies, especially when an existing plant is compared to a new one that is to be built. However, in any process with a large throughput of energy or materials and a long service life, such impacts are usually small compared to the operation (Svanström et al., 2017).

According to the results of this study, it seems clear that installing P recovery as part of or after DWWT will normally not incur large additional environmental costs compared to the current DWWT with regard to climate impact or energy use.

Recent LCA data on mineral fertiliser production are scarce. The reported climate impact of diammonium phosphate (DAP) (Zhang et al., 2017), which is the most widely used P-containing fertiliser, is 17 kg CO₂ eq/kg P. The P in this product was obtained from phosphate rock, and the product also contains some nitrogen. The authors state that the phosphoric acid entering the fertiliser production is responsible for almost half of the total impact; the low efficiency of use of phosphate rock and the heavy burden of pollutants emitted from phosphate mining are the main contributors (Zhang et al., 2017). The reported impact was in the same range as many of the results extracted in the present study (see the vertical line inserted in Fig. 4a). We can therefore assume that P recovered from DWW can likely replace mineral fertilisers without a considerable increase in environmental impacts, with the exception of some technologies that might need to be optimised or avoided.

The reader should be aware of some differences in the impact categories in this work. For example, the IPCC's recommended global warming potential values changed from the fourth to the fifth assessment report, increasing the characterisation factor for methane by 12% and decreasing it for nitrous oxide by 12%. The reports reviewed here include results from before and after this change and the consequential changes to LCIA methods like ReCiPe (see SM, section 7). It is infeasible to compensate for these changes given the absence of emission data by substance for all studies, however given that the results in Fig. 4 span orders of magnitude, we believe this change would not alter our qualitative conclusions.

It is also important to mention that potentially important environmental impact categories in this context were not fully captured in the comparison, for example eutrophication and resource use and depletion. Eutrophication is typically considered in LCA studies on dairy plants and is relevant for the assessment of any WWT, as this is an impact that the WWT itself aims to mitigate. Interestingly eutrophication was not always assessed in the literature on P recovery technologies (and never in a way that allowed cross-comparisons between the two groups of studies). In fact, in some of the reviewed LCA studies on P recovery

technologies, the eutrophication indicator was questioned because of its claimed inability to describe specific local conditions (Amann et al., 2018). Bradford-Hartke et al. (2015), Rodriguez-Garcia et al. (2014), and Zhang et al. (2020) found a significant eutrophication impact owing to the P recovery process. For AshDec® technology, the freshwater eutrophication potential (FEP) was found to be insignificant compared to other environmental impact categories (Bäfver et al., 2013; Heimerlsson et al., 2016; Svanström et al., 2017). As problems related to eutrophication and P resource depletion are likely the main reasons for P recovery in dairy products, further studies are needed to shed light on these potential issues. Regarding resource depletion, we believe that studies aiming to show the benefits of mineral recycling processes might reasonably be expected to include this indicator. It is to be hoped that detailed future LCA work will include detailed and disaggregated data on this indicator. From the point of view of P supply from dairy systems to other users, the presence of extensive agriculture in the upstream supply chain might also warrant the inclusion of land use and land use change as an indicator of resource use, in cases where allocation procedures are not considered to cut off wastewater from the upstream system.

4. Concluding remarks

It is challenging to find information on the life-cycle environmental performance of a combination of processes that does not yet exist. A meta-analysis of LCAs in literature was performed to provide information on a conceptual system involving P recovery in the context of DWWT. It was challenging to extract and compare results from different studies with different scopes and scales, but this article provides an example of how the lack of specific information at the early stages of process design can be overcome by collecting and refining data from earlier LCA studies. The study initially revealed that LCA studies on the dairy industry do not always include the DWWT process within their system boundaries. Eventually, nine relevant papers were found that assessed DWWT and six that assessed P recovery technologies. Differences in FUs, environmental impact categories, system boundaries, and type of inventory data used were considered in the meta-analysis and when needed, recalculations and rescaling was made.

Despite the treatment, in many cases, DWW still causes a significant part of the total eutrophication impact, primarily because of the remaining nutrients in the effluent. In general, the environmental impacts related to DWWT are strongly influenced by the scale of the dairy processing facility, as scale affects the possibilities of investing in technologies beyond the main production line.

The P recovery technologies examined here generally have a lower impact compared to DWWT with regard to climate impact and energy use, while the opposite is true for acidification. In general, the processes that recover from a liquid flow have a lower impact than when sludge is a P source. When sludge is incinerated and is recovered from an ash, the impact is typically even higher, but few of the considered technologies include incineration within the system boundary.

As pointed out and discussed in this paper, although the meta-analysis attempted to extract comparable information regarding two gate-to-gate systems, some gaps and overlaps remained and influenced the comparison. The boundary towards the further production of fertilisers was likely not consistent and any impacts or benefits related to the use of P products in agricultural activities were not included; therefore, further studies are needed.

Given the scope of the present study and the limited amount of data available in literature that fulfilled the requirements, we still deem this method of performing a meta-analysis of earlier LCAs as a useful alternative in the early stages of technology development, and also for this case. The analysis undertaken here extended our knowledge of the life cycle environmental impacts that can be expected of P recovery in a dairy context and provided useful guidance to the further technology development and environmental assessment within the REFLOW ETN

project. The generation of additional empirical information on P recovery technologies for DWW will help improve the accuracy and relevance of future studies. In designing P recovery for dairy contexts, particular attention should be paid to the impact of acidification, and LCA studies should also consider eutrophication and resource depletion.

CRedit authorship contribution statement

Marta Behjat: Conceptualization, Investigation, Writing – original draft, Writing – review & editing. **Magdalena Svanström:** Conceptualization, Supervision, Writing – review & editing, Funding acquisition. **Gregory Peters:** Conceptualization, Supervision, Writing – review & editing, Validation.

Declaration of competing interest

The authors declare that they have no known competing financial interests or personal relationships that could have appeared to influence the work reported in this paper.

Data availability

Data will be made available on request.

Acknowledgements

This study was part of the REFLOW (phosphorus recovery for fertilizers from dairy processing wastes) project, which is financially supported by the European Union's Horizon 2020 research and innovation program under grant agreement number 814258 (Marie Skłodowska - Curie Action). The authors also wish to thank Adlerbertska Forskningsstiftelsen for financial support.

Appendix A. Supplementary data

Supplementary data to this article can be found online at <https://doi.org/10.1016/j.jclepro.2022.133307>.

References

- Amann, A., Zoboli, O., Krampe, J., Rechberger, H., Zessner, M., Egle, L., 2018. Environmental impacts of phosphorus recovery from municipal wastewater. *Resour. Conserv. Recycl.* 130, 127–139.
- Ashkuzzaman, S.M., Forrestal, P., Richards, K., Fenton, O., 2019. Dairy industry derived wastewater treatment sludge: generation, type and characterization of nutrients and metals for agricultural reuse. *J. Clean. Prod.* 230, 1266–1275.
- Bradford-Hartke, Z., Lane, J., Lant, P., Leslie, G., 2015. Environmental benefits and burdens of phosphorus recovery from municipal wastewater. *Environ. Sci. Technol.* 49 (14), 8611–8622.
- Brazzale, P., Bourbon, B., Barrucand, P., Fenelon, M., Guercini, S., Tiarca, R., Mainar, M. S., 2019. Bulletin of the International Dairy Federation 500: Wastewater Treatment in Dairy Processing Innovative Solutions for Sustainable Wastewater Management. IDF, Brussels.
- Bäfver, L., Renström, C., Fahlström, J., Enfält, P., Skoglund, N., Holmén, E., 2013. Sambränsleblandningar – Förbränning och fosforutvinning. In: Swedish, Co-combustion Fuel Mixes – Combustion and Phosphorus Recovery. S P Sveriges Tekniska Forskningsinstitut, Borås, Sweden.
- Costea, D., Ghinea, C., 2021. Life cycle assessment of wastewater from dairy industry. *Food and Environment Safety Journal* 20.
- Dalla-Riva, A., Burek, J., Kim, D., Thoma, G., Cassandro, M., De-Marchi, M., 2017. Environmental life cycle assessment of Italian mozzarella cheese: hotspots and improvement opportunities. *J. Dairy Sci.* 100 (10), 7933–7952.
- Demirel, B., Yenigun, O., Onay, T.T., et al., 2005. Anaerobic treatment of dairy wastewaters: a review. *Process Biochem.* 40 (8), 2583–2595. In: <https://doi.org/10.1016/j.procbio.2004.12.015>.
- Djekic, I., Miocinovic, J., Tomasevic, I., Smigic, N., Tomic, N., 2014. Environmental life-cycle assessment of various dairy products. *J. Clean. Prod.* 68, 64–72.
- EDA, 2018. Economic Report 2017/18. EDA (European Dairy Association).
- Egle, L., Rechberger, H., Zessner, M., 2015. Overview and description of technologies for recovering phosphorus from municipal wastewater. *Resour. Conserv. Recycl.* 105, 325–346.
- Eide, M.H., 2002. Life Cycle Assessment (LCA) of industrial milk production. *Int. J. Life Cycle Assess.* 7 (2), 115–126.

- European Commission, 2006. Draft Reference Document on Best Available Techniques in the Food, Drink and Milk Industries. JRC, Seville.
- European Commission, 2009. Economic Impact of the Abolition of the Milk Quota Regime. JRC, Seville. https://ec.europa.eu/info/sites/info/files/food-farmin-g-fisheries/key_policies/documents/ext-study-milk-quota-full-report_2009_en.pdf.
- European Commission, 2016. Circular economy: new Regulation to boost the use of organic and waste-based fertilisers (MEMO/16/826). Brussels. https://ec.europa.eu/commission/presscorner/detail/en/IP_16_827.
- European Commission, 2017. Communication on the 2017 list of critical raw materials for the EU. <https://ec.europa.eu/transparency/regdoc/rep/1/2017/EN/COM-2017-490-F1-EN-MAIN-PART-1.PDF>.
- European Commission, 2019. Best Available Techniques (BAT) Reference Document for the Food, Drink and Milk Industries. Industrial Emissions Directive 2010/75/EU (Integrated Pollution Prevention and Control) - JRC118627. Publications Office of the European Union, Luxembourg.
- FIL-IDF, 2015. A Common Carbon Footprint Approach for Dairy Sector. The IDF Guide to Standard Life Cycle Assessment Methodology. International Dairy Federation, Brussels.
- Finnegan, W., Goggins, J., Clifford, E., Zhan, X., 2017. Environmental impacts of milk powder and butter manufactured in the Republic of Ireland. *Sci. Total Environ.* 579, 159–168.
- Gabrić, D., Galić, K., Timmerman, H., 2016. Chapter 31 - Cleaning of Surfaces. Handbook of Hygiene Control in the Food Industry. Woodhead Publishing, San Diego, pp. 447–463.
- González-García, S., Hospido, A., Moreira, M.T., Feijoo, G., Arroja, L., 2013. Environmental life cycle assessment of a Galician cheese: san Simon da Costa. *J. Clean. Prod.* 52, 253–262.
- Harder, R., Wielemaker, R., Larsen, T.A., Zeeman, G., Öberg, G., 2019. Recycling nutrients contained in human excreta to agriculture: pathways, processes, and products. *Crit. Rev. Environ. Sci. Technol.* 49 (8), 695–743.
- Heimersson, S., Svanström, M., Laera, G., Peters, G., 2016. Life cycle inventory practices for major nitrogen, phosphorus and carbon flows in wastewater and sludge management systems. *Int. J. Life Cycle Assess.* 21 (8), 1197–1212.
- Hermansson, F., Janssen, M., Svanström, M., 2019. Prospective study of lignin-based and recycled carbon fibers in composites through meta-analysis of life cycle assessments. *J. Clean. Prod.* 223, 946–956.
- Kim, D., Thoma, G., Nutter, D., Milani, F., Ulrich, R., Norris, G., 2013. Life cycle assessment of cheese and whey production in the USA. *Int. J. Life Cycle Assess.* 18 (5), 1019–1035.
- Kjerstadius, H., Saraiva, A.B., Spangberg, J., Davidsson, A., 2017. Carbon footprint of urban source separation for nutrient recovery. *J. Environ. Manag.* 197, 250–257.
- Linderholm, K., Tillman, A.M., Mattsson, J.E., 2012. Life cycle assessment of phosphorus alternatives for Swedish agriculture. *Resour. Conserv. Recycl.* 66, 27–39.
- Numviyimana, C., Warchol, J., Khalaf, N., Leahy, J.J., Chojnacka, K., 2022. Phosphorus recovery as struvite from hydrothermal carbonization liquor of chemically produced dairy sludge by extraction and precipitation. *J. Environ. Chem. Eng.* 10 (1), 106947.
- Rodríguez-García, G., Frison, N., Vázquez-Padín, J.R., Hospido, A., Garrido, J.M., Fatone, F., Bolzonella, D., Moreira, M.T., Feijoo, G., 2014. Life cycle assessment of nutrient removal technologies for the treatment of anaerobic digestion supernatant and its integration in a wastewater treatment plant. *Sci. Total Environ.* 490, 871–879.
- Schröder, J.J., Cordell, D., Smit, A., Rosemarin, A., 2010. Sustainable Use of Phosphorus. Wageningen UR.
- Shilpi, S., Seshadri, B., Sarkar, B., Bolan, N., Lamb, D., Naidu, R., 2018. Comparative values of various wastewater streams as a soil nutrient source. *Chemosphere* 192, 272–281.
- Skrydstrup, J., Larsen, S.L., Rygaard, M., 2020. Eco-efficiency of water and wastewater management in food production: a case study from a large dairy in Denmark. *J. Ind. Ecol.* 24 (5), 1101–1112.
- Slavov, A.K., 2017. General characteristics and treatment possibilities of dairy wastewater - a review. *Food Technol. Biotechnol.* 55 (1), 14–28.
- Stanchev, P., Vasilaki, V., Egas, D., Colon, J., Ponsá, S., Katsou, E., 2020. Multilevel environmental assessment of the anaerobic treatment of dairy processing effluents in the context of circular economy. *J. Clean. Prod.* 261.
- Svanström, M., Heimersson, S., Peters, G., Harder, R., F'Ons, D., Finnson, A., Olsson, J., 2017. Life cycle assessment of sludge management with phosphorus utilisation and improved hygienisation in Sweden. *Water Sci. Technol.* 75 (9–10), 2013–2024.
- Vagnoni, E., Franca, A., Porqueddu, C., Duce, P., 2017. Environmental profile of Sardinian sheep milk cheese supply chain: a comparison between two contrasting dairy systems. *J. Clean. Prod.* 165, 1078–1089.
- Vergé, X., Maxime, D., Dyer, J.A., Desjardins, R.L., Arcand, Y., Vanderzaag, A., 2013. Carbon footprint of Canadian dairy products: calculations and issues. *J. Dairy Sci.* 96, 6091–6104.
- Yan, M.J., Holden, N.M., 2019. Water use efficiency of Irish dairy processing. *J. Dairy Sci.* 102 (10), 9525–9535.
- Yapıcıoğlu, P., Yeşilnacar, M.I., 2020. Energy cost assessment of a dairy industry wastewater treatment plant. *Environ. Monit. Assess.* 192 (8), 536.
- Zhang, F., Wang, Q., Hong, J., Chen, W., Qi, C., Ye, L., 2017. Life cycle assessment of diammonium- and monoammonium-phosphate fertilizer production in China. *J. Clean. Prod.* 141, 1087–1094.
- Zhang, Y., Zhang, C., Qiu, Y., Li, B., Pang, H., Xue, Y., Liu, Y., Yuan, Z., Huang, X., 2020. Wastewater treatment technology selection under various influent conditions and effluent standards based on life cycle assessment. *Resour. Conserv. Recycl.* 154.