

Chapter 3

Electric Vehicle Modeling and Simulation Using MATLAB SIMULINK

M. Selvamuthukumar ^{a*}, D.Vinay Kumar ^b, M.Lokesh Madineni ^a

^aAssistant Professor, Department of Applied Engineering, Vignan's Foundation for Science, Technology and Research, Guntur, Andhra Pradesh

^bAssociate Professor, Department of Mechanical Engineering, Vignan's Foundation for Science, Technology and Research, Guntur, Andhra Pradesh

*Corresponding Author: m.selvamuthukumar@gmail.com

Abstract:

In this design, we design the electric vehicle model by using MATLAB SIMULINK tool blocks. Conventional vehicles give good performance and long range. But due to low energy frugality and exhaust gas emigrations causing environmental pollution, interest in electric vehicles is adding. The range of electric vehicles is short and they cannot reach high speed. Longer-distance vehicles are being produced as electric motor and battery technology advances. Thus, the performance of these vehicles can be optimized by opting for the motors and batteries depending on the region and the drive cycle. The dynamic model of an electric car was constructed utilizing MATLAB SIMULINK in this study. The energy consumption values of the electric vehicle and their range were determined for drive cycles similar to WLTP, NEDC, and HWFET. The factors of the Battery electric vehicle (BEV) frame were bandied then, and that model was dissembled on MATLAB SIMULINK and also the affiliated factors associated with the electrical systems.

Keywords: Electric vehicle, MATLAB SIMULINK, Simulation, Drive Cycles.

1. Introduction

Energy conservation is one of the most pressing issues confronting the world's climate. The global energy climate is also under threat. No one correctly predicts the future of energy; we believe that transportation will play a significant role in saving future energy. EVs are currently products of technological innovation that have contributed to making our lives easier and safer. EVs not only consume energy, but they also generate, store, and transport it. As a result, they are an excellent fuel vehicle option. The recent growth of hybrid and electric vehicles is strongly related to the need for highly efficient machines able to meet the most recent pollutant emissions regulations. In the automotive industry, electric propulsion is now a mature technology that is



already available on the market and capable of meeting pollutant emission regulations based on the most recent testing process. In recent days, Electric vehicles represent the most viable alternative to the IC engines. Batteries can perform differently depending on the operating temperature, actual capacity, and aging state [1].

The MATLAB/Simulink software, which is capable of modeling complete EV powertrains at various levels of fidelity and detail, has proven to be an invaluable modeling platform. This software features a variety of shipped sample models for simulation of pure battery electric as well as hybrid electric vehicles of different configurations and types. The MATLAB/Simulink platform supports many add-ons which have been used in vehicle modeling, such as Super systems and SimDriveline, Advisor Sims cape, Powertrain Block set, etc. For vehicle modeling, Simulink supports an equation-based, data-driven, and physical modeling approach. Simulink also supports hardware testing and deployment code generation, testing and analysis frameworks for test case management, and report generation. The literature contains numerous studies of MATLAB/Simulink models. However, methodologies for validating these models in a research set within a real-world environment have not been adequately addressed in the existing literature [2-5].

1.1. Block Diagram of Proposed Model:

It consists the following main blocks, 1.)Vehicle body, 2.)DC Motor, 3.)Power converter, 4.)Battery, 5.)Drive controller, 6.)Drive cycle

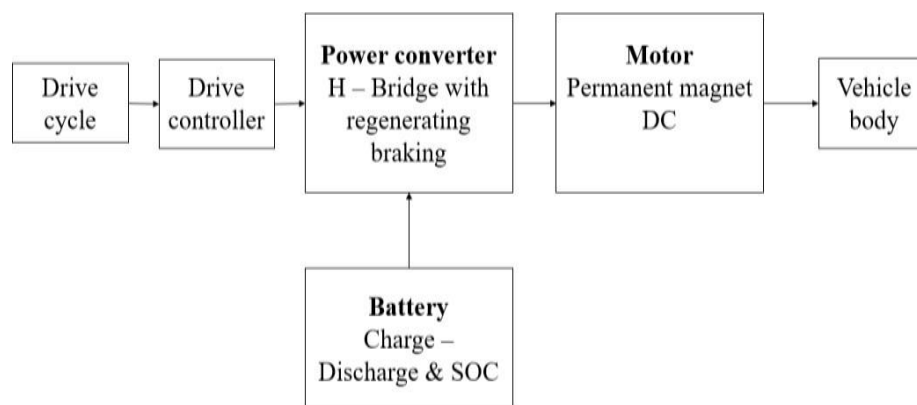

Figure 1: Block diagram of the proposed model



2. Tool Blocks Used

Vehicle Body: The Vehicle Body block represents a straight-line moving two-axle vehicle body. For example, two front axle wheels and one rear axle wheel. The block considers body mass, aerodynamic drag, road incline, and weight distribution between axles due to acceleration and road profile. Optionally include pitch and suspension dynamics. The vehicle's axles are parallel and form a plane. The longitudinal direction, x , is perpendicular to the axles and lies in this plane. If the vehicle is traveling on an inclined slope, the normal, z , direction is never parallel to gravity but always perpendicular to the axle-longitudinal plane [6-8].

- The vehicle motion is a result of the net effect of all the forces and torques acting on it.
- The weight mg of the vehicle acts through its center of gravity (CG).

$$mV_{x'} = F_x - F_d - mg \cdot \sin \beta$$

$$F_x = n(F_{xf} + F_{xr})$$

$$F_d = \frac{1}{2} \cdot C_d \rho A (V_x + V_w)^2 \cdot \text{sgn}(V_x + V_w)$$

- The normal force on each front and rear wheel.

$$F_{zf} = \frac{-h(F_d + mg \sin \beta + mV_{x'}) + b \cdot mg \cos \beta}{n(a+b)}$$

$$F_{zr} = \frac{+h(F_d + mg \sin \beta + mV_{x'}) + a \cdot mg \cos \beta}{n(a+b)}$$



- Pitch acceleration depends on three torque components and the inertia of the vehicle

$$a = \frac{(f \cdot h) + (F_z F_a) - (F_z r b)}{J}$$

Where:

a is the pitch acceleration.

f is the longitudinal force.

h is the height of the center of gravity when measured parallel to the z-axis.

J is inertia.

Tire: The tire's longitudinal direction is the same as its motion as it rolls on the pavement. Based on the Tire-Road Interaction (Magic Formula) block, this is a structural component. You can specify tire compliance, inertia, and rolling resistance to improve the fidelity of the tire model. These properties, however, add to the complexity of the tire model and can slow down the simulation. If you are simulating the model in real-time or preparing it for hardware-in-the-loop (HIL) simulation, consider ignoring tire compliance and inertia.

DC Motor: The DC Motor block uses the following equivalent circuit model to represent the electrical and torque characteristics of a DC motor. The resistor R is equivalent to the resistance specified in the Armature resistance parameter. The inductor L is equivalent to the inductance specified in the Armature inductance parameter.

- The permanent magnets in the motor cause the armature to experience the following back emf v_b .

$$v_b = k_v \omega$$

where k_v denotes the Back-emf constant and angular velocity motor produces the following torque, which is proportional to the motor current I

$$T_E = k_t I$$

Where, k_t is the Torque constant

2.1 Power Controller:

The tool blocks in a DC motor power controller are (a) H-Bridge and (b) Controlled PWM Voltage.

H-Bridge: The H-Bridge block represents an H-bridge motor driver. The block's simulation mode options are as follows: 1) PWM, 2) Mean The H-Bridge block's output is a controlled voltage determined by the input signal at the PWM port. When the input signal exceeds the Enable threshold voltage parameter value, the H-Bridge block



output is activated and has a value equal to the Output voltage amplitude parameter value. The averaged model is the other mode. Smoothed and unsmoothed load current characteristics are available in this mode. The Smoothed option assumes that the current is nearly continuous due to load inductance.

Controlled PWM Voltage: A pulse-width modulated (PWM) voltage source is represented by the Controlled PWM Voltage block. Select either electrical or physical signal input ports in the Modeling option parameter. The block calculates the duty cycle by using the reference voltage across its ref+ and ref- ports. You can directly specify the duty cycle value by using an input physical signal port [9-10].

Drive Cycle: A standard or user-specified longitudinal drive cycle is generated by the Drive Cycle Source block. The output of the block is the specified vehicle longitudinal speed, which can be used to

- Estimate the engine torque and fuel consumption required by a vehicle to achieve the desired speed and acceleration for a given gear shift reference.
- Create realistic velocity and shift references for vehicle control and plant models' closed loop acceleration and braking commands.
- Study, tune, and optimize vehicle control, system performance, and system robustness over multiple drive cycles.
- Identify the faults within tolerances specified by standardized tests, including EPA dynamometer drive schedules

Battery: A high-fidelity battery model is represented by the Battery block. The block computes no-load voltage as a function of charge level and includes several modelling options. 1). Self-discharge, 2) Battery Fade, 3) Charge Dynamics, and 4) Charge Dynamics Ageing by the calendar. The Battery (Table-Based) block has four modelling variants, which can be accessed by right-clicking the block in your block diagram and then selecting the appropriate option from the context menu, which can be found under Simscape > Block choices. Uninstrumented No thermal port, Uninstrumented show thermal port, Instrumented show thermal port. The instrumented models have an additional physical signal port that outputs the internal state of charge. Use this functionality to change load behaviour as a function of charge state without having to build a charge state estimator. The fundamental battery model, the self-discharge resistance RSD, the charge dynamics model, and the series resistance R0 comprise the battery equivalent circuit [11].

Simple Gear: The Simple Gear block represents a gearbox that constrains the connected driveline axes of the base gear, B, and follower gear, F, to corotate with a



specified fixed ratio. You can specify whether the follower axis rotates in the same direction as the base axis or in the opposite direction. The angular velocity of the follower, ω_F , and the angular velocity of the base, ω_B , have the same sign if they rotate in the same direction. ω_F and ω_B have opposite signs if they rotate in opposite directions. Backlash, faults, and thermal effects can be easily added and removed [12-13].

- The kinematic constraint that the Simple Gear block imposes on the two connected axes is

$$r_F \omega_F = r_B \omega_B$$

where:

r_F is the radius of the follower gear.

ω_F is the angular velocity of the follower gear.

r_B is the radius of the base gear.

ω_B is the angular velocity of the base gear.

3. Proposed Model

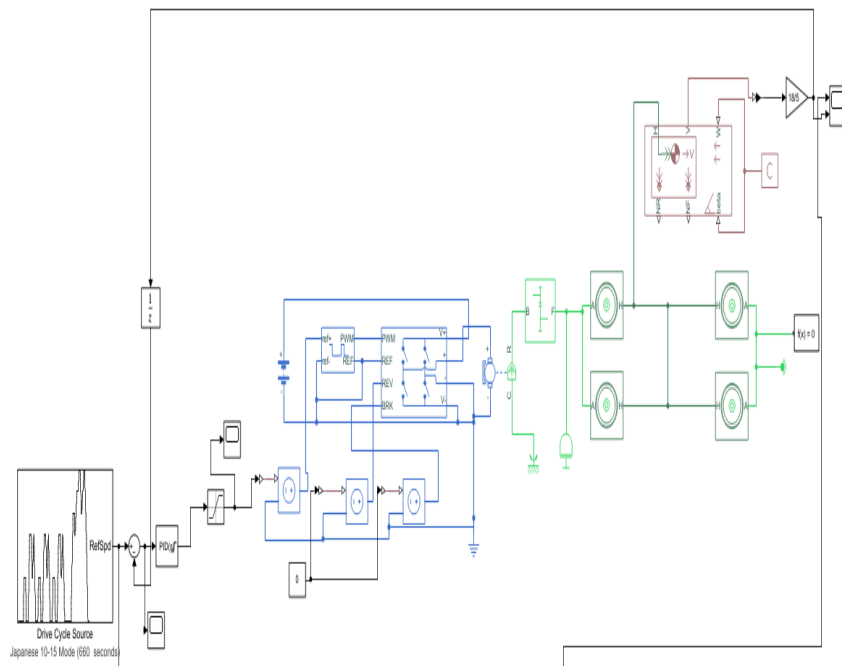

Figure 2: MATLAB SIMULINK MODEL of an Electric Vehicle



3.1. Simulation Results

After designing and modeling the MATLAB SIMULINK was used to create an electric vehicle. Some simulation has to be performed in order to assess the electric vehicle battery capacity, range, speed, and time for acceleration and deceleration, idle time, and cruise time. Also, according to the model, the main parameter is to plot the difference in the rated speed of the vehicle and the actual speed of the vehicle by taking feedback from the vehicle body [14].

- Simulation results of given input drive cycles are shown in figures A1 and A2.
- Simulation results of the PWM voltage signal are shown in Figures B1 and B2.
- Simulation results of the velocity of rated and actual velocity for a given input drive cycle are shown in Figures C1, and C2

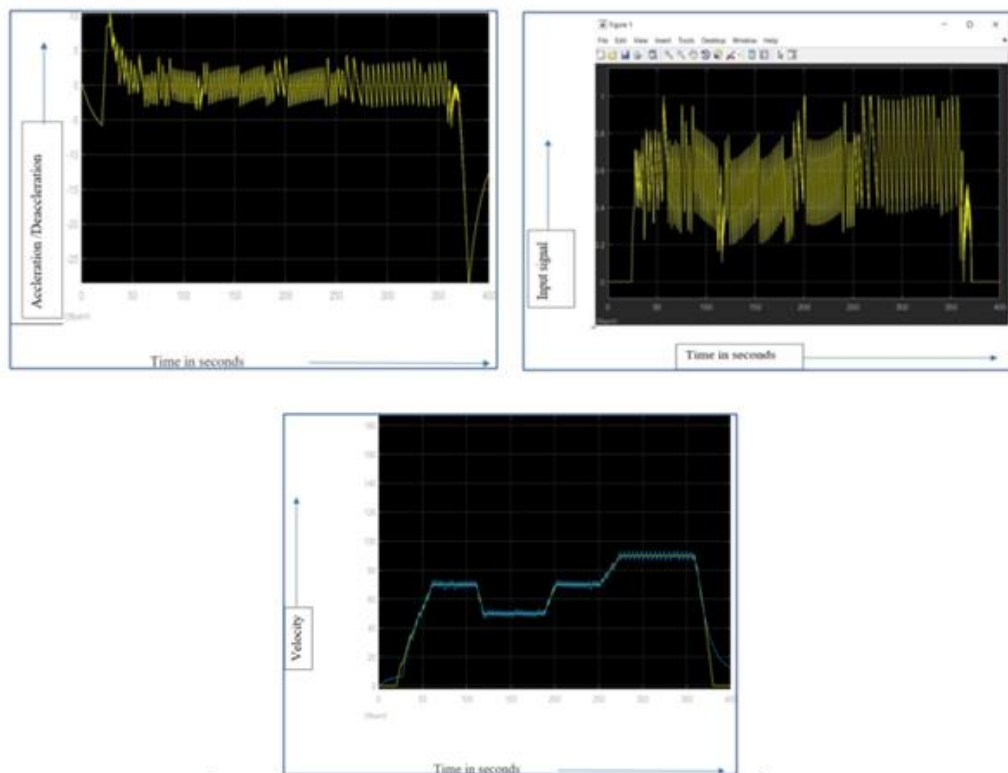

Figure 3: Extra Urban Drive Cycle



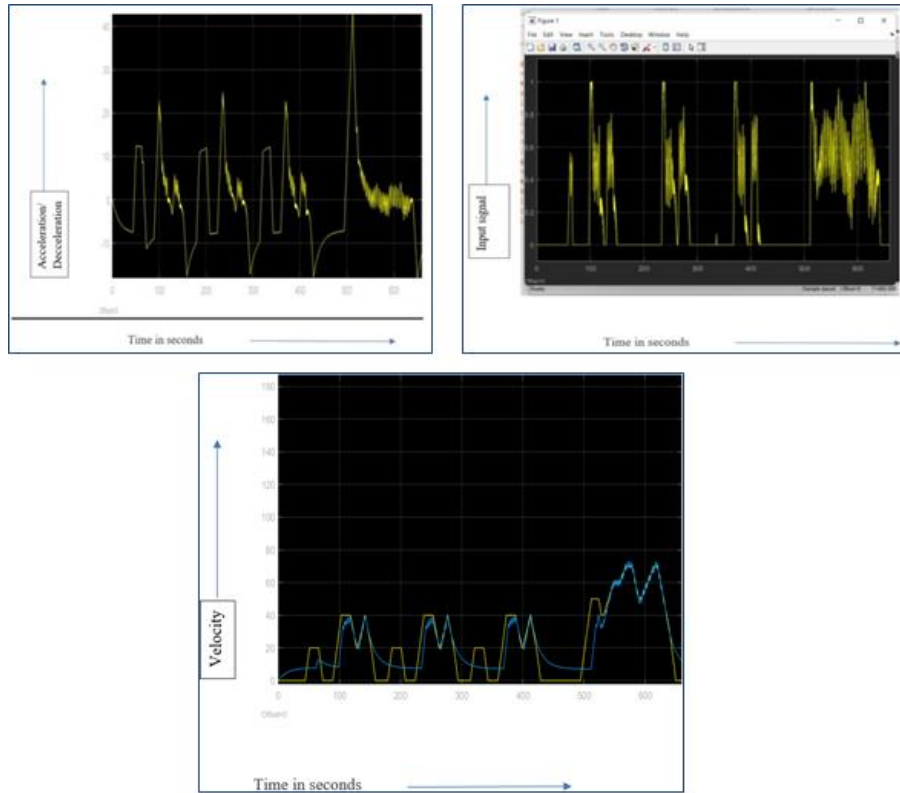

Figure 4: Japanese 10-15 Mode Driving Cycle

4. Conclusion

Modeling an electric vehicle system makes it simple to figure out how much battery capacity an electric car with specified specifications needs to travel a certain distance.

- This model can be used to measure the performance of a vehicle throughout the starting process or when running at a constant speed, as well as to estimate how long the battery can be utilized.
- In this project, we model an Electric Vehicle while taking in to consideration its all the basic system of vehicle body parameters, DC motor, H Bridge, PID Controller, Driver Cycle input.
- We get the feedback input from vehicle body and we sorted it by using descret PID controller.



Reference

- [1] K. Venkata Rao, Bachina Harish Babu, V. Umasai Vara Prasad, A study on effect of dead metal zone on tool vibration, cutting and thrust forces in micro milling of Inconel 718, *Journal of Alloys and Compounds*, Volume 793, 2019, Pages 343-351, ISSN 0925-8388, <https://doi.org/10.1016/j.jallcom.2019.04.194>.
- [2] Babu, B.H., Rao, K.V. & Ben, B.S. Modeling and optimization of dead metal zone to reduce cutting forces in micro-milling of hardened AISI D2 steel. *J Braz. Soc. Mech. Sci. Eng.* 43, 142 (2021). <https://doi.org/10.1007/s40430-021-02861-5>.
- [3] M. Selvamuthukumar, B. Harish babu, Sujith bobba, S. Baskar, Nivin Joy, Investigation on the lubricating behavior of cashew nut shell liquid oil as a renewable and reliable petrochemical product, *Materials Today: Proceedings*, Volume 44, Part 5, 2021, Pages 3583-3588, ISSN 2214-7853, <https://doi.org/10.1016/j.matpr.2020.09.458>.
- [4] Palakuru Mahesh , Sirisha Adamala , Harish Babu Bachina, Application of Space-Born Remote Sensing To Analyze Forest Cover in Chittoor (India) Area, *International Journal for Research in Applied Science & Engineering Technology (IJRASET)* ISSN: 2321-9653; IC Value: 45.98; SJ Impact Factor :6.887 Volume 6 Issue I, January 2018- Available at www.ijraset.com.
- [5] Krishna Reddy, Y.V., Sirisha Adamala and Bachina Harish Babu. 2017. Case Study on Performance Evaluation of Drip Irrigation Systems in Selected Villages of Guntur District, Andhra Pradesh, India. *Int.J.Curr.Microbiol.App.Sci.* 6(2): 437-445. doi: <http://dx.doi.org/10.20546/ijcmas.2017.602.049>
- [6] MAHESH PALAKURU, SIRISHA ADAMALA, & HARISH BABU BACHINA. (2020). Modeling yield and backscatter using satellite derived biophysical variables of rice crop based on Artificial Neural Networks. *Journal of Agrometeorology*, 22(1), 41-47. <https://doi.org/10.54386/jam.v22i1.120>.
- [7] P. Manoj Kumar , Bachina Harish Babu, S. Gowtham & K. Rajesh, Development And Study Of Tribological Properties Of Bio composite For Brake Pad Application, *International Journal of Mechanical and Production Engineering Research and Development (IJMPERD)* ISSN (P): 2249-6890; ISSN (E): 2249-8001 Vol. 7, Issue 6, Dec 2017, 263-270.
- [8] M Shri, Bachina Harish Babu, V. Harish, Syed Riyaz Ahammed, R Hushien, Manoj Kumar, Optimized Water Pumping System Using Arduino For Home Automation, *International Journal of Mechanical Engineering and Technology (IJMET)* Volume 8, Issue 8, August 2017, pp. 1412-1416, Article ID: IJMET_08_08_145 Available online at <http://iaeme.com/Home/issue/IJMET?Volume=8&Issue=8> ISSN Print: 0976-6340 and ISSN Online: 0976-6359.
- [9] Bobba, S., Selvamuthukumar M., Harishbabu, B., & Leman, Z. (2022). Solar-Based Mosquito Trap for Household Purposes. *International Journal of Social Ecology and Sustainable Development (IJSESD)*, 13(1), 1-10. <http://doi.org/10.4018/IJSESD.288536>
- [10] Sujith Bobba, Z. Leman , B. Harish Babu, Environmental effects on the mechanical properties of E-glass and S-glass fiber epoxy composite ring specimens used in aircraft fuel pipes, *Incas Bulletin*, Volume 13, Issue 4/ 2021, Pp. 17 - 24 (P) Issn 2066-8201, (E) Issn 2247-4528.
- [11] Bobba, S., Mukkollu, S. R., Leman, Z., & Bachina, H. B. (2021). Experimental



- Investigation on the Effect Due to Mould Vibrations on Mechanical and Metallurgical Properties of Aluminum Alloy (A-1050). *International Journal of Surface Engineering and Interdisciplinary Materials Science (IJSEIMS)*, 9(1), 77-86. <http://doi.org/10.4018/IJSEIMS.2021010105>.
- [12] Bachina Harish Babu, Dillip Kumar Sahoo, Study of Tribological and Thermal Properties of Engine Lubricant by Dispersion of Aluminium Nano Additives. , *Revue des Composites et des Matériaux Avancés*, Apr2020, Vol. 30 Issue 2, p103-107. 5p.
- [13] Sujith Bobba, Mukkollu Sambasiva Rao, B. Harish Babu, Z. Leman (2020). Effect on the Mechanical Properties of Grey Cast Iron with Variation of Molybdenum and AS - Cast Alloying Elements. *Universal Journal of Mechanical Engineering*, 8(6), 298 - 304. DOI: 10.13189/ujme.2020.080602.
- [14] R Prabhu, Bachina Harish Babu, M Selvamuthukumar, N Poiyyamozhi, Nanocomposites in food packaging, *Int. J. Recent. Technol. Eng* 2, 2277-3878.

<https://doi.org/10.5281/zenodo.7628173>

SCIENTIFIC RESEARCH REPORTS
www.srrbooks.in

