

## DESIGN OF A MODERN FASTENING AND LOOSENING DEVICE FOR MACHINING OF PLATE-TYPE PARTS ON A MILLING MACHINE

**Abdullayeva Dona Toshmatovna**

Fergana Polytechnic Institute, Republic of Uzbekistan

### ABSTRACT

In the course of the study, an analysis of the manufacturability of the part was carried out. The type of production was determined in accordance with the annual production program and the design of the part. In accordance with the type of production, as well as the material of the part, a blank was selected. Calculations of allowances, tolerances, technological dimensions, cutting modes, main and auxiliary times, work piece clamping force for milling have been carried out.

As a result of the study, a technological process for manufacturing a part was designed and a special device for milling was designed.

**Keywords.** technology, allowance, cutting parameters, tolerance, base plate.

## РАЗРАБОТКА СОВРЕМЕННОГО КРЕПЕЖНО-РАСКРУЧИВАЮЩЕГО ПРИПОСОБЛЕНИЯ ДЛЯ ОБРАБОТКИ ПЛАСТИНЧАТЫХ ДЕТАЛЕЙ НА ФРЕЗЕРНОМ СТАНКЕ.

**Абдуллаева Дона Ташматовна**

Ферганского политехнического института, Республика Узбекистан

### АННОТАЦИЯ

В процессе исследования выполнен анализ технологичности детали. Определен тип производства в соответствии с годовой программой выпуска и конструкцией детали. В соответствии с типом производства, а также материалом детали произведен выбор заготовки. Проведены расчеты припусков, допусков, технологических размеров, режимов резания, основного и вспомогательного времени, усилия зажима заготовки на фрезерование.

В результате исследования спроектирован технологический процесс изготовления детали и спроектировано специальное приспособление для фрезерования.

**Ключевые слова.** технология, припуск, режимы резания, допуск, опорная плита.

## FREZALASH DASTGOHIDA PLITA TIPIDAGI DETALLARGA ISHLOV BERISH UCHUN MAHKAMLOVCHI VA BO‘SHATUVCHI ZAMONAVIY MOSLAMA LOYIHALASH

**Abdullayeva Dona Toshmatovna**

Farg‘ona politexnika instituti

### ANNOTATSIYA

Tadqiqot jarayonida detalning ishlab chiqarish tahlili o‘tkazildi. Ishlab chiqarish turi yillik ishlab chiqarish dasturiga va detalning dizayniga muvofiq aniqlandi. Ishlab chiqarish turiga, shuningdek, detalning materialiga qarab tanlangan. Texnologik o‘lchamlar, kesish rejimlari, asosiy va yordamchi vaqtlar, frezalash uchun ish qismini siqish kuchi hisob-kitoblari amalga oshirildi.

Tadqiqotlar natijasida qismni ishlab chiqarishning texnologik jarayoni loyihalashtirildi va frezalash uchun maxsus qurilma loyihalashtirildi.

**Kalit** so‘zlar: texnologiya, qo‘yimlar, kesish shartlari, bardoshlik, taglik plitasi.

A device for fixing parts of the "plate" type when processing their inner contour on a milling or slotting machine, containing a body on which there are supporting base plates for installing the frame to be processed, as well as side clamps designed to fix the frame along its lateral surfaces, characterized in that that it is equipped with side and end stops installed on the body, designed to press the side and end surfaces of the frame to them, respectively, by pressing mechanisms, and the mechanism for pressing the side surface of the frame to the side stop is made in the form of a clamp installed at the end of a screw screwed into a threaded hole a strap fixed to the body, and the mechanism for pressing the end surface of the frame to the stop is made in the form of a body installed in the bore with the possibility of reciprocating movement and rotation of the stuck, spring-loaded relative to the body and fastened with a threaded rod installed in the body, onto the threaded part which a clamping nut is screwed on, while each of the side clamps is made in the form of an L-shaped grip, mounted in the bore of the body with the possibility of reciprocating movement and rotation, and is spring-loaded relative to the body, and in each clamp there is an axial hole through which a threaded rod is passed, one threaded end of which is screwed into the body, and on the other there is screwed a clamping nut in contact with the clamp.

The article relates to the field of tooling for metal-cutting machines and can be used to fix a wide range of parts of the "frame" type when processing them on milling and slotting machines.

Parts of the “plate” type refer to planar parts, the inner contour of which is formed by one or more cavities (windows) communicating with each other or made separately. Details of the "frame" type are generally characterized by a square, rectangular or elongated shape, a wide range of sizes and varying rigidity. When processing the inner contour of such parts, it is necessary to accurately install and fix them, as well as to exclude their deformation and displacement of the position of the part in the fixture during its clamping, this is especially important for parts of significant sizes, even minor deformation and displacement of which relative to the base elements when fixing them leads to significant processing errors. The internal contours of such parts are usually machined on milling machines, and the radius surfaces of the mating of linear contours are machined on slotting machines. Therefore, it is important, when installing parts in a fixture, to arrange the fixture’s clamping elements in such a way as to ensure that the inner contour can be machined with a minimum number of part reinstallations. The surface of the inner contour can be perpendicular to its planes, or made at a different angle to them.

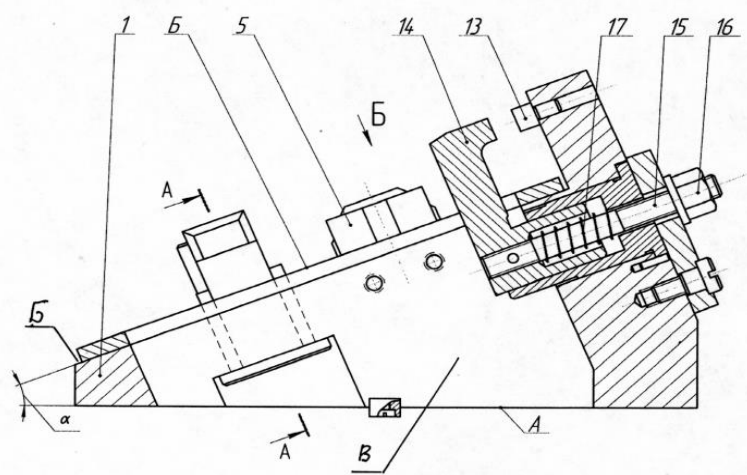

**Fig.1.** Design of a modern fastening and loosening device for machining of plate-type parts on a milling machine.

It is known an adaptation to a milling machine for fixing a part, comprising a body on which support strips are fixed, designed to install the part to be processed and move it to a predetermined position to the stop installed on the body, as well as a mechanism for securing the part, made in the form of two racks fixed to the body, on which pressure levers are mounted on the axles, connected by means of rods with a drive for their rotation to fix (unfasten) the part.

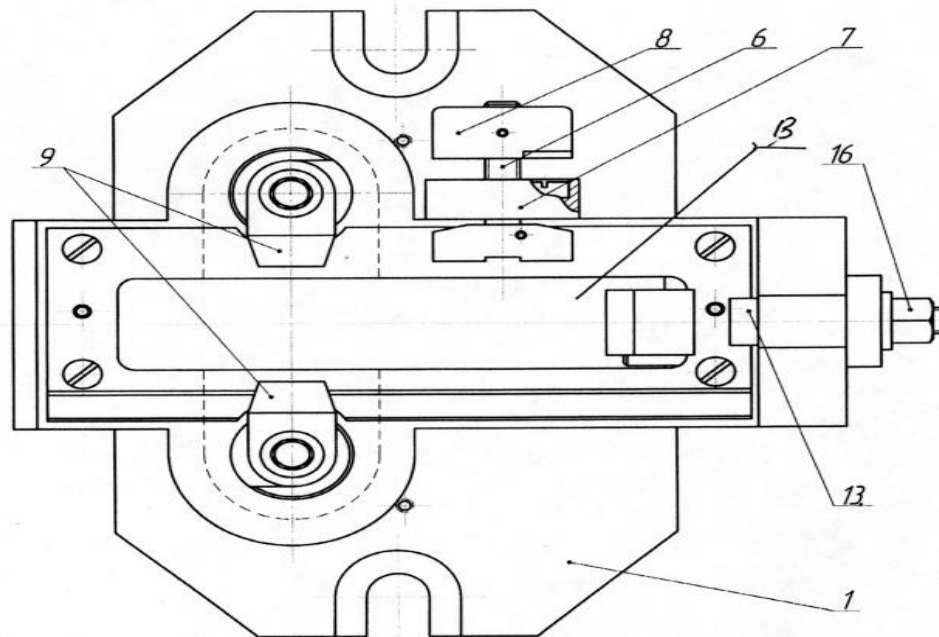

**Fig.2.** Design of a modern fastening and loosening device for machining of plate-type parts on a milling machine (horizontal view).

As a result of the analysis of the known device, it should be noted that its disadvantage is that the coordinated movement of the clamping levers requires high accuracy of their dimensions, because even a small different magnitude of their stroke can lead to displacement of the part when it is fastened, and, consequently, to a decrease in the accuracy of processing the part.

A device for fastening parts is known, comprising a housing, in parallel bores of which bushings are fixed. In the bushings with the possibility of axial reciprocating movement and rotation, there are rotary clamping L-shaped levers spring-loaded relative to the body, on which there are clamping elements. The ends of the L-shaped levers are connected to the rocker arm. The device is equipped with a mechanism for fixing the part with L-shaped levers, made in the form of a plunger, in which there is a groove for installing a roller, which is mounted on an axis with the possibility of rotation.

As a result of the analysis of the known device, it should be noted that it, like the claimed device, is intended for fixing flat parts. The fixation of the part in the device is carried out by clamps along the upper plane of the part to the base surface of the body without the use of mounting stops, which does not allow it to be oriented to a precisely specified position. In addition, when clamping a work piece, it may be displaced relative to the position set during installation due to the contact of the clamps with the surface of the work piece to be processed. All this reduces the accuracy of the part machining.

The technical result of this utility model is the development of a device that secures flat-shaped parts - frames with their fixation in a precisely specified position, which increases the accuracy of processing their inner contour.

### REFERENCES:

1. Axunbabaev, O. A., & Karimov, R. J. (2022). Improving the process of back compaction in the formation of natural silk fabric on the loom. *Science and Education*, 3(2), 236-240.
2. Усманов, Д. А., Умарова, М. О., Абдуллаева, Д. Т., & Рустамова, М. М. (2022). УПАКОВКА КИП ХЛОПКА: ТЕХНИЧЕСКИЕ НОРМЫ ЗАГРУЗКИ ИХ В ВАГОНЫ. *Universum: технические науки*, (3-2 (96)), 38-42.
3. Onorboyev, O. A. O., & Karimov, R. J. O. (2022). Determining the optimal variant of mechanical processing of polymer composite materials. *Science and Education*, 3(3), 180-185.
4. Toshmatova, A. D. (2021). FARG‘ONA VILOYATI PAXTA TERISH MASHINALARINING ZAMONAVIY TEXNOLOGIYALARGA INTEGRATSIYASINI TADQIQ QILISH. *Oriental renaissance: Innovative, educational, natural and social sciences*, 1(11), 457-464.
5. Robiljonov, I. I. O., & Karimov, R. J. O. G. L. (2021). IMPROVING THE EFFICIENCY OF MACHINING OF PARTS MADE OF STAINLESS MATERIALS. *Scientific progress*, 2(8), 581-587.
6. Jaxongir o‘g‘li, R. K., Toshmatovna, A. D., Muxtoraliyevna, R. M., & Xakimjon o‘g‘li, T. I. (2021). PROGRESSIVE CONSTRUCTIONS OF ADJUSTABLE SHEET PUNCHING STAMPS. *EURASIAN JOURNAL OF SOCIAL SCIENCES, PHILOSOPHY AND CULTURE*, 46.
7. Ergashev, I. O., Karimov, R. J. O. G. L., Karimov, R. X., & Nurmatova, S. S. (2021). KOLOSNIK ALMASHINUVCHI MASHINASI ELEMENTI EGILISHINING NAZARIY TADQIQOTLARI. *Scientific progress*, 2(7), 83-87.
8. Mirzaxojaev, S. D. O., & Karimov, R. J. O. G. L. (2021). RESEARCH OF MECHANICAL PROCESSING PROCESS ON THE BASIS OF MODERN METHODS OF MEASUREMENT AND CONTROL. *Scientific progress*, 2(8), 575-580.
9. Abdullayeva, D. T., & Turg‘unbekov, A. M. O. G. L. (2021). ПРОДЛЕНИЕ СРОКА ХРАНЕНИЯ ЛИСТОВЫХ ДЕТАЛЕЙ ПРОКАТНОГО ОБОРУДОВАНИЯ. *Oriental renaissance: Innovative, educational, natural and social sciences*, 1(11), 1035-1045.

10. Tojiboyev R.K., Ulmasov A.A., Muxtorov Sh. 3M strukturaviy bog'lovchi lenta 9270 // Fan va ta'lim. 2021. №4. URL: <https://cyberleninka.ru/article/n/3m-structural-bonding-tape-9270>
11. Axunbabaev, O. A., & Karimov, R. J. (2022). Improving the process of back compaction in the formation of natural silk fabric on the loom. *Science and Education*, 3(2), 236-240.
12. Усманов, Д. А., Умарова, М. О., Абдуллаева, Д. Т., & Рустамова, М. М. (2022). УПАКОВКА КИП ХЛОПКА: ТЕХНИЧЕСКИЕ НОРМЫ ЗАГРУЗКИ ИХ В ВАГОНЫ. *Universum: технические науки*, (3-2 (96)), 38-42.
13. Onorboyev, O. A. O., & Karimov, R. J. O. (2022). Determining the optimal variant of mechanical processing of polymer composite materials. *Science and Education*, 3(3), 180-185.
14. Toshmatova, A. D. (2021). FARG'ONA VILOYATI PAHTA TERISH MASHINALARINING ZAMONAVIY TEXNOLOGIYALARGA INTEGRATSIYASINI TADQIQ QILISH. *Oriental renaissance: Innovative, educational, natural and social sciences*, 1(11), 457-464.
15. Robiljonov, I. I. O., & Karimov, R. J. O. G. L. (2021). IMPROVING THE EFFICIENCY OF MACHINING OF PARTS MADE OF STAINLESS MATERIALS. *Scientific progress*, 2(8), 581-587.
16. Jaxongir o'g'li, R. K., Toshmatovna, A. D., Muxtoraliyevna, R. M., & Xakimjon o'g'li, T. I. (2021). PROGRESSIVE CONSTRUCTIONS OF ADJUSTABLE SHEET PUNCHING STAMPS. *EURASIAN JOURNAL OF SOCIAL SCIENCES, PHILOSOPHY AND CULTURE*, 46.
17. Ergashev, I. O., Karimov, R. J. O. G. L., Karimov, R. X., & Nurmatova, S. S. (2021). KOLOSNIK ALMASHINUVCHI MASHINASI ELEMENTI EGILISHINING NAZARIY TADQIQOTLARI. *Scientific progress*, 2(7), 83-87.
18. Mirzaxojaev, S. D. O., & Karimov, R. J. O. G. L. (2021). RESEARCH OF MECHANICAL PROCESSING PROCESS ON THE BASIS OF MODERN METHODS OF MEASUREMENT AND CONTROL. *Scientific progress*, 2(8), 575-580.
19. Abdullayeva, D. T., & Turg'unbekov, A. M. O. G. L. (2021). ПРОДЛЕНИЕ СРОКА ХРАНЕНИЯ ЛИСТОВЫХ ДЕТАЛЕЙ ПРОКАТНОГО ОБОРУДОВАНИЯ. *Oriental renaissance: Innovative, educational, natural and social sciences*, 1(11), 1035-1045.
20. Tojiboyev R.K., Ulmasov A.A., Muxtorov Sh. 3M strukturaviy bog'lovchi lenta 9270 // Fan va ta'lim. 2021. №4. URL: <https://cyberleninka.ru/article/n/3m-structural-bonding-tape-9270>

21. Toshkoziyeva, Z., & Muxtorov, S. (2022). DESIGN ANALYSIS FOR THE PRODUCTION OF PLATE HANDLES FOR CAR WINDSHIELDS. *Journal of Integrated Education and Research*, 1(1), 164–172. Retrieved from <https://ojs.rmasav.com/index.php/ojs/article/view/34>.
22. Toshkoziyeva, Z., & Muxtorov, S. (2022). ANALYSIS OF THE REQUIREMENTS FOR MODERN HEAT EXCHANGERS AND METHODS OF PROCESS INTENSIFICATION. *Journal of Integrated Education and Research*, 1(1), 140–149. Retrieved from <https://ojs.rmasav.com/index.php/ojs/article/view/30>.
23. Toshqo‘ziyeva, Z., & Muxtorov, S. (2022). AVTOMABILLARNI 3M STRUKTURALI ULASH LENTASI BILAN MAXKAMLANUVCHI PLASTINA TUTQICHI KONSTRUKSIYALARINI TAXLILI. *Journal of Integrated Education and Research*, 1(1), 114–125. Retrieved from <https://ojs.rmasav.com/index.php/ojs/article/view/27>.
24. Sherzod Sobirjon O‘G‘Li Muxtorov, & Islombek Ikromjon O‘G‘Li Qoxxorov (2022). Issiqlik almashuvchi qurilmalar va ularda jarayonni intensivlash usullari tahlili. *Science and Education*, 3 (5), 370-378.
25. <https://www.grnjournals.us/index.php/ajshr/article/view/728>.
26. Махмудов, А., & Мухторов, Ш. (2022). ВЛИЯНИЕ ИНДИВИДУАЛЬНОГО УВЛАЖНИТЕЛЯ НА ОБРЫВНОСТЬ НИТЕЙ ОСНОВЫ В ПРОЦЕССЕ ТКАЧЕСТВА. *Eurasian Journal of Academic Research*, 2(13), 884–890. извлечено от <https://www.in-academy.uz/index.php/ejar/article/view/7639>.
27. Махмудов, А., & Мухторов, Ш. (2022). ИССЛЕДОВАНИЕ ОСНОВНОГО ПЛАНЕТАРНОГО РЕГУЛЯТОРА. *Eurasian Journal of Academic Research*, 2(13), 879–883. извлечено от <https://in-academy.uz/index.php/ejar/article/view/7638>.
28. Valikhonov Dostonbek Azim ogli, & Nurmatova Salimakhon Sobirovna. (2022). A METHOD OF CALCULATING THE DEPTH OF CUT IN A LATHE AFTER ROLLING ON A ROUGH PART. *Galaxy International Interdisciplinary Research Journal*, 10(2), 77–83. Retrieved from <https://www.giirj.com/index.php/giirj/article/view/1201>.
29. Salima Sobirovna Nurmatova (2022). Yoqilg‘ining ekspluatatsion samaradorligini oshirish. *Science and Education*, 3 (5), 622-626.
30. Nurmatova, S. S. (2022). Universal xarakteristikalardan foydalanib dvigatelning ish hajmini o‘zgartirish orqali uni boshqarishda samaradorlik ko‘rsatkichlarini tadqiq etishning hisob-eksperimental usuli. *Science and Education*, 3(5), 627-632.
31. Ergashev, I. O. Rustam Jaxongir o‘g‘li Karimov, Ravshan Xikmatullayevich Karimov, & Salimaxon Sobirovna Nurmatova (2021). Kolosnik.
32. Турғунбеков Аҳмадбек Махмудбек Ўғли, & Маматкулова Дилдора Нуриддиновна (2022). КОНСТРУКЦИЯ И РАБОЧИЙ ПРОЦЕСС ФРЕЗЫ ДЛЯ

ХОЛОДНОЙ РЕКУЛЬТИВАЦИИ ДОРОГ. *Universum: технические науки*, (5-3 (98)), 8-11.

33. Турғунбеков Ахмадбек Махмудбек Ўғли (2022). МЕТОДИКА ВЫБОРА БИОМЕХАНИЧЕСКОГО МОДЕЛИРОВАНИЯ. *Universum: технические науки*, (5-3 (98)), 5-7.

34. Yusufjonov Otabek, Ro‘Zaliyev Hojiakbar, & Turgunbeqov Axmadbek (2022). EXPERIMENTAL STUDIES OF THE TECHNOLOGICAL PROCESS OF PROCESSING CONCAVE SURFACES OF COMPLEX SHAPES. *Universum: технические науки*, (5-10 (98)), 48-50.

35. Бахадиров, Гайрат Атаханович , Эргашев, Илхомжон Олимжонович, Цой, Герасим Николаевич, & Набиев, Айдер Мустафаевич (2022). УСТРОЙСТВО ДЛЯ ОПРЕДЕЛЕНИЯ СИЛЫ ВТЯГИВАНИЯ ПЛОСКОГО МАТЕРИАЛА МЕЖДУ РАБОЧИМИ ВАЛКОВЫМИ ПАРАМИ. *Nazariy va amaliy tadqiqotlar xalqaro jurnali*, 2 (3), 66-73. doi: 10.5281

36. Эргашев, Илхомжон Олимжонович (2022). АРРАЛИ ДЖИН КОЛОСНИКЛАРИ АЛМАШУВЧИ ЭЛЕМЕНТЛАРИНИ КОНСТРУКТИВ ЎЛЧАМЛАРИНИ АСОСЛАШ. *Nazariy va amaliy tadqiqotlar xalqaro jurnali*, 3, 88-97. doi: 10.5281/zenodo.6503659odo.6503605

37. Бахадиров, Г. А., Цой, Г. Н., Набиев, А. М., & Эргашев, И. О. (2022). Экспериментальный Отжим Капиллярно-Пористого Материала На Металлокерамической Опорной Плите. *Central Asian Journal of Theoretical and Applied Science*, 3(5), 100-109. Retrieved from <https://cajotas.centralasianstudies.org/index.php/CAJOTAS/article/view/499>

38. Fayzimatov Shukhrat Nomonovich, Ergashev Ilhomjon Olimjonovich, & Valikhonov Dostonbek Azim o‘g‘li. (2022). Effects Of Crushing on Cutting and Cleaning of Surface Facilities in Cutting and Processing of Polymer Materials. *Eurasian Research Bulletin*, 4, 17–21. Retrieved from <https://www.geniusjournals.org/index.php/erb/article/view/353>

39. Ilhom Olimjonovich Ergashev, Rustam Jaxongir O‘G‘Li Karimov, Ravshan Xikmatullayevich Karimov, & Salimaxon Sobirovna Nurmatova (2021). KOLOSNIK ALMASHINUVCHI MASHINASI ELEMENTI EGILISHINING NAZARIY TADQIQOTLARI. *Scientific progress*, 2 (7), 83-87

40. Ergashev Ilhomjon Olimjonovich, & Mahmudov Nasimbek Odilbekovich. (2022). Calculation of Carrier and Interchangeable Element Combination. *Eurasian Journal of Engineering and Technology*, 5, 68–73. Retrieved from <https://www.geniusjournals.org/index.php/ejet/article/view/1162>



41. Мухаммадиев, Д. М., Ахмедов, Х. А., & Эргашев, И. О. (2020). Расчет перемещений вставки относительно колосник. In *Инновационные исследования: теоретические основы и практическое применение* (pp. 103-105).
42. Мухаммадиев, Д. М., Ахмедов, Х. А., Эргашев, И. О., Жамолова, Л. Ю., & Мухаммадиев, Т. Д. (2020). Силовой расчет соединений колосника пильного джина со вставкой. *Известия высших учебных заведений. Технология текстильной промышленности*, (1), 137-143.
43. МамажоновичХ. А. (2021). Влияние Натяжения Нитей Основы На Обрывность Ее При Ткачестве. *Central Asian Journal of Theoretical and Applied Science*, 2(12), 178-183. Retrieved from <https://cajotas.centralasianstudies.org/index.php/CAJOTAS/article/view/328>
44. Sherzod Sobirjon O'G'Li Muxtorov, & Islombek Ikromjon O'G'Li Qoxxorov (2022). Issiqlik almashuvchi qurilmalar va ularda jarayonni intensivlash usullari tahlili. *Science and Education*, 3 (5), 370-378.