

Energy Storage Arbitrage and Peak Shaving in Distribution Grids Under Uncertainty

Lysandros Tziiovani, Lenos Hadjidemetriou, Stelios Timotheou

KIOS Research and Innovation Center of Excellence and Department of Electrical and Computer Engineering

University of Cyprus

Nicosia, Cyprus

{ltziiov01, lhadji02, stimo}@ucy.ac.cy

Abstract—Energy storage systems can provide peak shaving services in distribution grids to enable an increased penetration of renewable energy sources and load demand growth. Moreover, storage owners can make profits through energy arbitrage in electricity markets by buying energy when the price is low and selling when the price is high. This work considers the energy scheduling of a storage system integrated in a transformer substation to minimize the transformer power limit violations and maximize the arbitrage profits. However, uncertainty on the electricity price and net-load demand of the distribution grid may cause a mismatch between scheduled and actual operation, causing transformer power violations and reduced arbitrage profits. Towards this direction, a scenario-based stochastic optimization scheme to make uncertainty-aware decisions is developed, considering both net-load and price uncertainty. The corresponding scheme is formulated as a linear program that can be solved efficiently even under a large number of scenarios. The performance of the proposed scheme is evaluated and compared to the corresponding deterministic scheme using net-load profiles from a real distribution grid and price data from the Spanish day-ahead electricity market. The developed scheme can be used for enhancing both the bidding and operating strategy of a storage system.

Index Terms—Distribution grids, energy arbitrage, energy storage systems, peak shaving, stochastic optimization

I. INTRODUCTION

Energy storage systems (ESSs) is an emerging technology that can be used to compensate the negative effects of the increasing penetration of renewable energy sources (RESs) into the power system. ESSs can provide several services to the power grid, such as frequency control, energy shifting, and peak shaving [1]. Moreover, with the evolution of electricity markets, ESSs can take advantage of market operation and make profits using energy arbitrage.

Energy arbitrage strategies that buy and store energy when electricity prices are low and sell when the prices are high to maximize profits are proposed in [2]–[4]. Specifically, these strategies consider the energy management of prosumers in distribution grids [2], the ESSs operation for reducing the

peak load of a distribution substation [3], and the market bidding and operation of an ESS participating in day-ahead and real-time electricity markets [4]. Price and load uncertainty is ignored in [2] and [3], while a stochastic formulation to make decisions under price uncertainty is presented in [4].

Peak shaving strategies to ensure the operational limits of distribution feeders under an increased RES penetration and load demand growth are proposed in [5]–[9]. The strategies in [5]–[7] provide only peak shaving services, ignoring the electricity prices. Both peak shaving and energy arbitrage strategies are presented in [8] and [9]. In [8], a deterministic scheme is developed that uses forecasts of the feeder load and day-ahead electricity prices, while a stochastic scheme that handles the load and generation uncertainty is developed in [9]. However, the price uncertainty is ignored in both works; thus, reduced arbitrage profits may result from the bidding strategies in day-ahead markets when the price forecasting error is high. In addition, mixed-integer optimization problems are formulated in [3], [4], [6], [9] which are hard to solve.

This work develops an optimization scheme for the energy scheduling of an ESS to provide peak shaving services to a power transformer as well as to maximize the arbitrage profits under uncertainty. The contributions of the paper are: 1) the building of a scenario-based stochastic optimization model to make uncertainty-aware decisions, considering both grid net-load demand¹ and price uncertainty, 2) the formulation of the corresponding model as a linear program, integrating a relaxed ESS model, that can be solved efficiently even under a large number of scenarios, 3) the performance evaluation of the proposed stochastic scheme with the corresponding deterministic optimization scheme using net load and price data from a real distribution grid and the Spanish day-ahead electricity market. The proposed stochastic scheme can be used for bidding and operating strategies.

For the rest of this paper the problem statement and solution methodology to develop the deterministic and stochastic optimization schemes are described in Sections II and III. The scenario selection methodology is explained in Section IV and simulation results are presented in Section V. Finally, conclusions are given in Section VI.

This work was supported in part by the European Regional Development Fund and the Republic of Cyprus through the Research and Innovation Foundation under Project INTEGRATED/0916/0035 - EMPOWER; in part by the European Union's Horizon 2020 Research and Innovation Programme under grant agreement No 957739 (OneNet); and in part by the European Union's Horizon 2020 research and innovation programme under grant agreement No 739551 (KIOS CoE - TEAMING) and from the Republic of Cyprus through the Deputy Ministry of Research, Innovation and Digital Policy.

¹Grid net-load demand: The load demand minus the RES generation of the distribution grid.

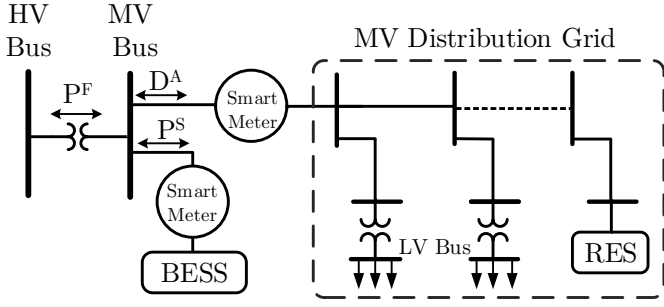

Fig. 1. An integrated BESS in an HV/MV transformer substation for peak shaving and energy arbitrage purposes.

II. PROBLEM STATEMENT

This work considers the usage of a battery energy storage system (BESS) integrated in a high voltage/medium voltage (HV/MV) transformer substation for peak shaving and energy arbitrage purposes. At the MV side, a BESS is directly connected to the substation through an MV feeder, while a second feeder is used to serve an MV distribution grid with high RES penetration, as shown in Fig. 1.

A. Objective Function

Energy arbitrage and peak shaving are achieved by managing the BESS power set-points to maximize the arbitrage profits and minimize the transformer power limit violations, given by

$$\text{minimize } \Delta T \left(- \sum_{t \in \mathcal{T}} c_t^A P_t^S + W \sum_{t \in \mathcal{T}} x_t \right), \quad (1)$$

where $\mathcal{T} = \{1, \dots, T\}$ denotes the considered time horizon and ΔT the time-step duration in hours. Variables P_t^S denote the BESS charging (negative values) and discharging (positive values) power and x_t the transformer power violations. Parameters c_t^A and W denote the electricity price for energy arbitrage at time t in €/MWh and a penalty term that controls the trade-off between maximizing arbitrage profit and minimizing power violations. This work aims to eliminate the power violations to protect the transformer; thus, the value of W must be selected sufficiently large. As a result, the arbitrage profit is maximized as far as it does not create power violations.

B. Constraints

1) *Power Balance*: According to Fig. 1, the power balance at the MV bus is defined as

$$P_t^F + P_t^S = D_t^A, \quad \forall t \in \mathcal{T}, \quad (2)$$

where variables P_t^F and constants D_t^A denote the transformer power and net-load demand of the MV grid at time-step t in MW, respectively.

2) *Power Violations*: The soft constraint that ensures the operational limits, \underline{P}^F and \overline{P}^F , of the power transformer is expressed as

$$\underline{P}^F - x_t \leq P_t^F \leq \overline{P}^F + x_t, \quad \forall t \in \mathcal{T}. \quad (3)$$

The penalization of x_t in (1) aims to avoid the overloading of the transformer.

3) *BESS Model*: To model the BESS we consider the relaxed but convex model that we proposed in [2]

$$C_{t+1} = C_t + \Delta T (-P_t^S - P_t^L), \quad \forall t \in \mathcal{T}, \quad (4a)$$

$$C_0 = I, \quad \underline{C} \leq C_t \leq \overline{C}, \quad \forall t \in \mathcal{T}, \quad (4b)$$

$$-\overline{P}^c \leq P_t^S \leq \overline{P}^d, \quad \forall t \in \mathcal{T}, \quad (4c)$$

$$P_t^L \geq e^d P_t^S, \quad P_t^L \geq (-e^c) P_t^S, \quad \forall t \in \mathcal{T}, \quad (4d)$$

$$P_t^L \leq e^c \overline{P}^c + \alpha (P_t^S + \overline{P}^c), \quad \forall t \in \mathcal{T}, \quad (4e)$$

where variables C_t and P_t^L denote the BESS state-of-charge (SoC) in MWh and power losses in MW, respectively. Constants \underline{C} and \overline{C} denote the minimum and maximum SoC limits, I the initial SoC, and \overline{P}^c and \overline{P}^d the charging and discharging power limits. In addition, e^c and e^d denote the charging and discharging power losses coefficients, such that $e^d = 1/\eta^d - 1$ and $e^c = 1 - \eta^c$ where η^d and η^c are the corresponding one-way efficiency ratios, and $\alpha = (e^d \overline{P}^d - e^c \overline{P}^c) / (\overline{P}^d + \overline{P}^c)$. This model is exact, generating the optimal solution, when equality is attained in one of the two constraints in (4d). More information regarding this model is given in [2].

Parameters D_t^A and c_t^A presented in (1) and (2) are the actual grid net-load demand and electricity prices, defined as

$$D_t^A = D_t^P + \xi_t, \quad \forall t \in \mathcal{T}, \quad (5a)$$

$$c_t^A = c_t^P + \psi_t, \quad \forall t \in \mathcal{T}, \quad (5b)$$

where D_t^P and c_t^P are the predicted net load and electricity prices, while ξ_t and ψ_t are the prediction errors at time-step t , respectively. D_t^A and c_t^A are generally unknown as they are associated with future information; hence, D_t^A and c_t^A are replaced by D_t^P and c_t^P in the deterministic optimization problem (1)-(4e). Note that high prediction errors may cause a mismatch between scheduled and actual operation, causing reduced arbitrage profits and transformer power limit violations. This problem is addressed in the next section.

III. SOLUTION METHODOLOGY

This section builds on the formulation of Section II to develop a scenario-based stochastic optimization scheme that makes uncertainty-aware BESS decisions, considering both net-load and price uncertainty.

A. Objective Function

For the stochastic optimization scheme we consider the set of scenarios $\mathcal{S} = \{1, \dots, S\}$ with $S = |\mathcal{S}|$; each scenario concerns the net-load demand and electricity price of the considered horizon \mathcal{T} . Let constants $c_{t,s}$ and variables $\hat{x}_{t,s}$ denote the electricity prices and the transformer power limit violations at time-step t of scenario s , respectively. In this case, the objective (1) is reformulated to maximize and minimize the weighted-average arbitrage profit and power violations, respectively, across all scenarios, yielding

$$\text{minimize } \Delta T \left(- \sum_{s \in \mathcal{S}} w_s \sum_{t \in \mathcal{T}} c_{t,s} P_t^S + W \sum_{s \in \mathcal{S}} w_s \sum_{t \in \mathcal{T}} \hat{x}_{t,s} \right), \quad (6)$$

where constants w_s denote the weighting parameter of scenario s such that $\sum_{s \in \mathcal{S}} w_s = 1$. Note that the BESS charging/discharging power, P_t^S , denotes the operating decision variables; thus, is scenario independent.

B. Constraints

1) *Power Balance and Violations*: The constraints in (2) and (3) are reformulated to consider the scenarios, yielding

$$\hat{P}_{t,s}^F + P_t^S = D_{t,s}, \quad \forall t \in \mathcal{T}, \forall s \in \mathcal{S}, \quad (7a)$$

$$\underline{P}^F - \hat{x}_{t,s} \leq \hat{P}_{t,s}^F \leq \bar{P}^F + \hat{x}_{t,s}, \quad \forall t \in \mathcal{T}, \forall s \in \mathcal{S}, \quad (7b)$$

where variables $\hat{P}_{t,s}^F$ and constants $D_{t,s}$ denote the transformer power and grid net-load demand at time-step t of scenario s .

2) *BESS Model*: The constraints of the relaxed BESS model remain the same with the deterministic scheme, constraints (4a)-(4e), because P_t^S is scenario independent.

The stochastic scheme can be used for (a) bidding strategies in day-ahead markets by submitting the buying/selling power, defined by $P_t^S \forall t \in \mathcal{T}$, for the next day and (b) operating strategies by applying this scheme in a model predictive control framework during the actual BESS operation.

IV. SCENARIO SELECTION

This section explains the methodology of selecting the scenario curves for the net-load demand and electricity prices that are used in the stochastic scheme. Assuming that prediction data are unavailable, we utilize only historical data. Let day D denote the current day and $D+1$ the day ahead where we aim to determine the BESS decisions $P_t^S \forall t \in \mathcal{T}$. We assume that the decisions are made at the end of day D , enabling the use of the actual price and load data of this day. Let $\mathcal{N} = \{D-N+1, \dots, D\}$ and $\mathcal{M} = \{D-M+1, \dots, D\}$ denote the set of the previous days where the corresponding load and price curves of the last N and M days are used, respectively. The importance factors $\mathbf{f} = [1/N, 2/N, \dots, N/N]$ and $\hat{\mathbf{f}} = [1/M, 2/M, \dots, M/M]$ are introduced for each demand and price curve, aiming to assign an increasing importance on daily profiles closer to day D . The weights of the load and price curves are defined as

$$\phi_n = f_n / \sum_i f_i, \quad n = \{1, \dots, N\}, \quad (8a)$$

$$\hat{\phi}_m = \hat{f}_m / \sum_j \hat{f}_j, \quad m = \{1, \dots, M\}, \quad (8b)$$

where f_n is the n element of vector \mathbf{f} . To deal with the two source of uncertainty, we build the scenario tree presented in Fig. 2 where each scenario $s \in \mathcal{S}$ represents a combination of a single load and price curve with $w_s = \phi_n \cdot \hat{\phi}_m$. Thus, the total number of scenarios are $S = N \cdot M$. In the deterministic scheme we use the actual demand and price curves of day D as the prediction data.

V. SIMULATION RESULTS

This section investigates the performance of the deterministic and stochastic optimization schemes using historical net-load data from a real distribution grid in Larnaca, Cyprus.

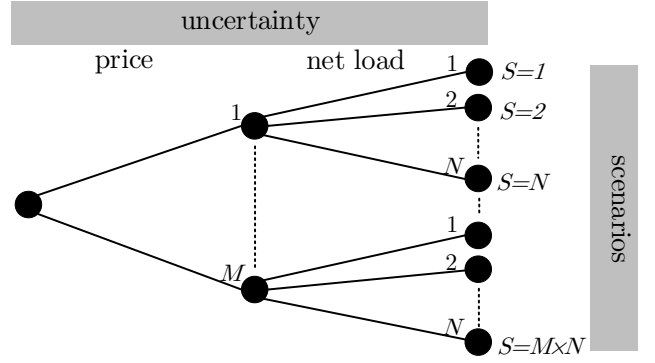

Fig. 2. Scenario tree.

Electricity price data are obtained from the Spanish day-ahead electricity market [10], because the Cypriot electricity market has not commenced operation yet. Currently, power violations do not occur in the real power transformer; however, to emulate the power violations and to use currently available net-load profiles we reduce the transformer upper and lower limits to $\bar{P}^F = 2.2$ MW and $\underline{P}^F = -1.8$ MW, respectively. In addition, we consider a BESS with usable capacity of 2 MWh, 4 MW charging and discharging power, and 96% one-way efficiency. The penalty cost W is set to 100,000 to eliminate the transformer power violations.

The considered problems are coded in Matlab and solved using optimization solver Gurobi [11] on a personal computer with 8 GB RAM and an Intel Core-i5 3.2 GHz processor. The horizon is set to one day with 30-minute time intervals.

The optimization schemes are evaluated for each day of the period 01/03/2020-31/12/2020 utilizing the real net-load and price data, where the scenarios for the stochastic scheme and the predicted curves for the deterministic approach are selected according to Section IV. Next, Section V-A studies the performance of both schemes for a single day, Section V-B demonstrates aggregate results, and Section V-C presents the execution times of the stochastic scheme for different number of scenarios.

A. Performance evaluation

The performance of the deterministic and stochastic scheme is studied for a randomly selected evaluation day (18/07/2020).

1) *Deterministic scheme*: The actual net-load demand and energy price curves of the evaluation day along with the demand and price curves of the previous day, 17/07/2020, used as prediction data in the deterministic scheme are illustrated in Figs. 3(a)-(b). The BESS charging/discharging decisions made by the optimization scheme based on the prediction data are shown in Fig. 4(a), indicating the BESS charging and discharging power during low and high energy prices, respectively. The BESS SoC based on the charging/discharging power is demonstrated in Fig. 4(b). Fig. 5 depicts the scheduled transformer power obtained from the deterministic scheme and the actual transformer power resulting from applying the BESS charging/discharging decisions considering the actual curves. Although the scheduled transformer power is between the limits, the actual transformer power exceeds the limits due

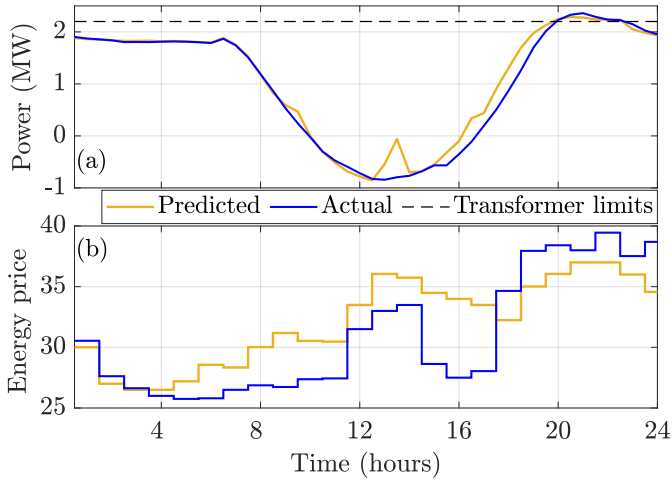

Fig. 3. (a) Net-load demand curves (MW) and (b) day-ahead energy prices (€/MWh). The demand and price curves for 17/07/2020 are used as the predicted curves in the deterministic scheme, while the actual curves for 18/07/2020 are used for evaluation.

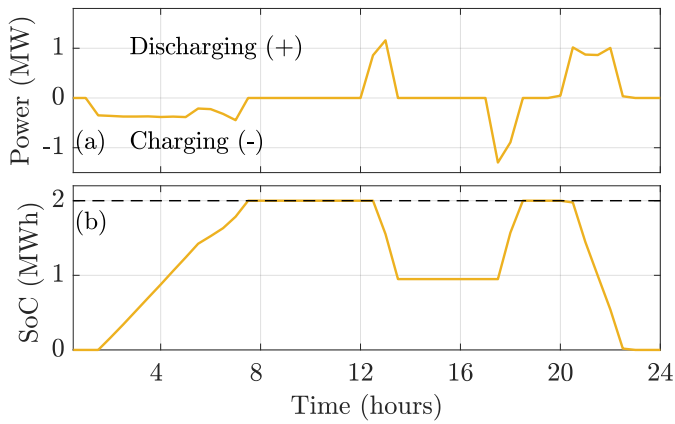

Fig. 4. BESS decisions using the deterministic scheme for 18/07/2020: (a) BESS charging/discharging power (MW) and (b) SoC (MWh).

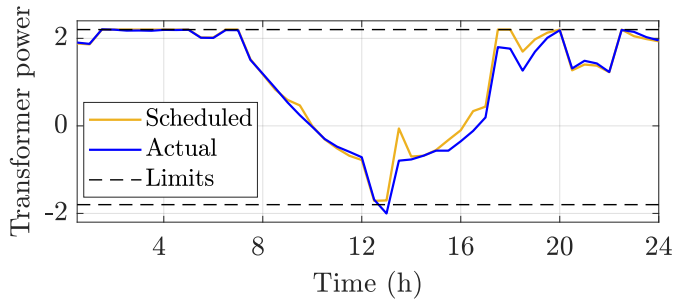

Fig. 5. The scheduled transformer power (MW) obtained from the deterministic scheme and the actual transformer power for 18/07/2020.

to the net-load prediction error. As a result, the actual energy violations are 0.104 MWh, while the arbitrage profit is 14.65 €. To protect the transformer when energy violations occur, load shedding or RES curtailments may be applied which are undesirable.

2) *Stochastic scheme*: To construct the scenario set \mathcal{S} , we utilize the net-load curves for 18/06/2020-17/07/2020 ($N = 30$) as well as the price curves for 08/07/2020-17/07/2020 ($M = 10$) presented in Figs. 6(a)-(b). The BESS charging/discharging decisions and SoC are shown in Figs.

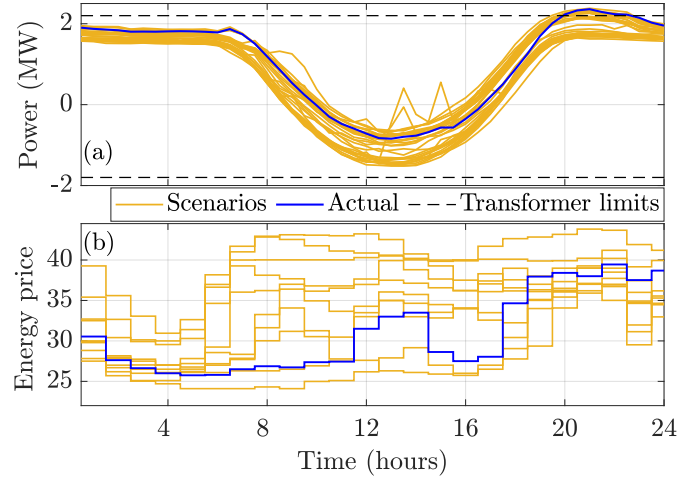

Fig. 6. (a) Net-load demand curves (MW) and (b) day-ahead energy prices (€/MWh). The demand curves for 18/06/2020-17/07/2020 and price curves for 08/07/2020-17/07/2020 are used as the scenarios in the stochastic scheme, while the actual curves for 18/07/2020 are used for evaluation.

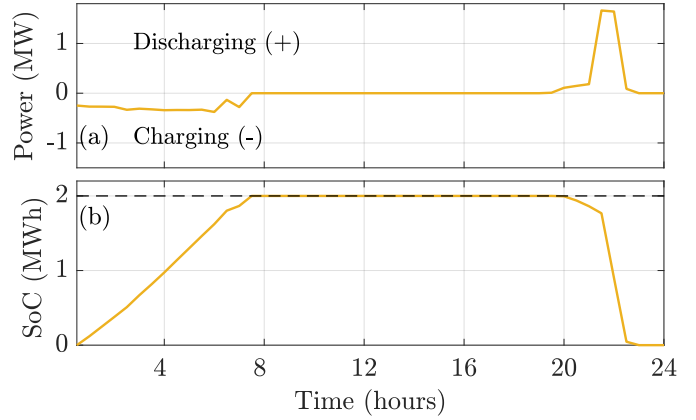

Fig. 7. BESS decisions using the stochastic scheme for 18/07/2020: (a) BESS charging/discharging power (MW) and (b) SoC (MWh).

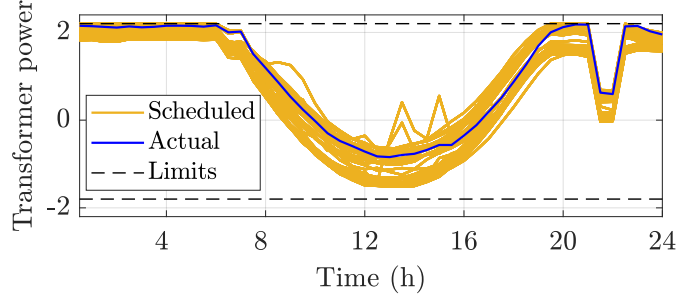

Fig. 8. The scheduled transformer power (MW) obtained from the stochastic scheme for each scenario and the actual transformer power for 18/07/2020.

7(a)-(b), observing the BESS charging and discharging during the early morning and evening when the scenario prices are low and high, respectively. Since the net-load curves exceed the transformer upper limit during the evening (see Fig. 6(a)), the BESS discharging during these hours prevents the power violations as can be seen by the scheduled transformer power of each scenario in Fig. 8. The uncertainty-aware decisions made by the stochastic scheme result in 0 MWh actual energy violations and 19.43 € arbitrage profit, 32.62% higher than the deterministic scheme.

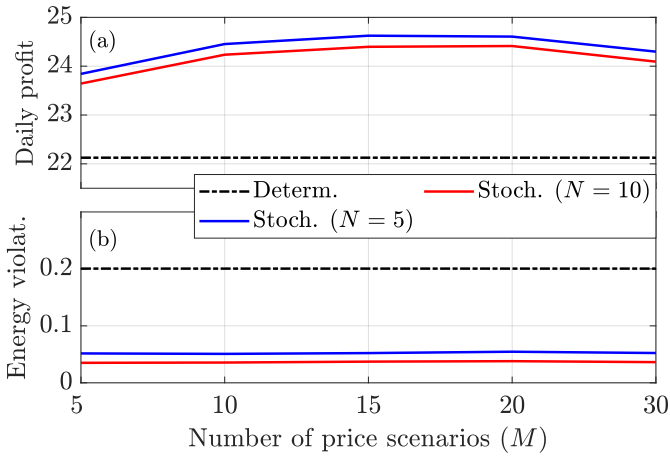

Fig. 9. Aggregate daily results for the stochastic optimization problem under a different number of electricity price scenarios: (a) Average daily profits (€) and (b) average energy violations (MWh).

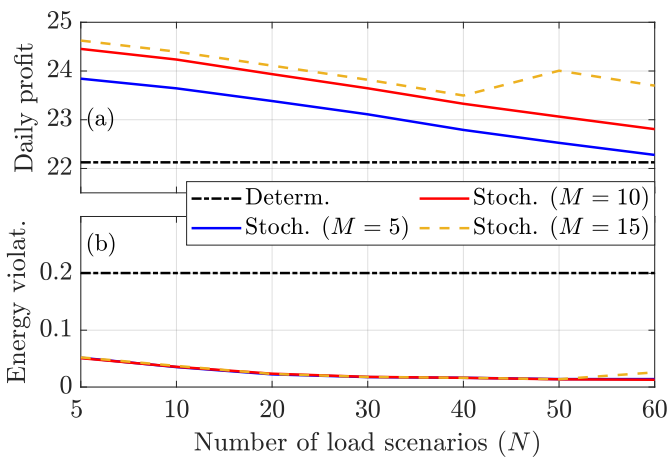

Fig. 10. Aggregate daily results for the stochastic optimization problem under a different number of net-load scenarios: (a) Average daily profits (€) and (b) average energy violations (MWh).

B. Aggregate performance evaluation

The aggregate performance of the two optimization schemes is investigated for the evaluation period 01/03/2020-31/12/2020. Fig. 9 shows the actual average (a) daily profits and (b) energy violations resulting from the deterministic and stochastic scheme for varying number of price scenarios (M). It is observed that the energy violations remain constant when the number of price scenarios increases, while the maximum arbitrage profits are achieved for $15 \leq M \leq 20$. Fig. 10 demonstrates the reduction of the energy violations when the number of load scenarios (N) increases; however, the arbitrage profits are also reduced. The superiority of the stochastic scheme compared to the deterministic scheme is demonstrated in both Figs. 9 and 10, always achieving higher arbitrage profits and lower energy violations. Selecting the scenarios in a more sophisticated way, e.g., utilizing prediction schemes, can yield even better performance. Note that the BESS relaxation exactness is always satisfied in the simulation results, obtaining the optimal solution.

TABLE I
EXECUTION SPEED FOR DIFFERENT NUMBER OF SCENARIOS

$S = 500$ ($N = 50, M = 10$)	$S = 1000$ ($N = 50, M = 20$)	$S = 2000$ ($N = 50, M = 40$)
1.36 s	2.81 s	11.31 s

C. Execution speed

The execution speed of the stochastic optimization scheme under an increasing number of scenarios for the evaluation day 18/07/2020 is presented in Table I. The small execution times indicate that the formulated linear program can be solved efficiently even under a large number of scenarios.

VI. CONCLUSIONS

This work develops a scenario-based stochastic optimization scheme for the energy scheduling of a BESS integrated in a transformer substation to provide peak shaving services and maximize arbitrage profits under net-load demand and price uncertainty. The proposed scheme as well as the corresponding deterministic scheme are formulated as linear programs that can be solved efficiently. Two main remarks can be drawn from the results. First, the stochastic scheme achieves significant better performance compared to the deterministic scheme, increasing the actual arbitrage profits and reducing the actual energy violations. Second, the appropriate selection of price and net-load scenarios is critical because the price scenarios can increase the arbitrage profits, while the net-load scenarios can eliminate the energy violations but reduce the arbitrage profits. The proposed scheme can be used to define both the bidding and operating strategies of a BESS.

REFERENCES

- [1] N. Günter et al., "Energy storage for grid services and applications: Classification, market review, metrics, and methodology for evaluation of deployment cases," *Journal of Energy Storage*, vol. 8, p. 226–234, 2016.
- [2] L. Tziiovani et al., "Energy Management and Control of Photovoltaic and Storage Systems in Active Distribution Grids," *IEEE Trans. Power Systems*, vol. 37, no. 3, pp. 1956–1968, May 2022.
- [3] S. F. Schneider et al., "Rechargeable Batteries for Simultaneous Demand Peak Shaving and Price Arbitrage Business," *IEEE Trans. Sustainable Energy*, vol. 12, no. 1, pp. 148–157, Jan. 2021.
- [4] D. Krishnamurthy et al., "Energy Storage Arbitrage Under Day-Ahead and Real-Time Price Uncertainty," *IEEE Trans. Power Systems*, vol. 33, no. 1, pp. 84–93, Jan. 2018.
- [5] L. Tziiovani et al., "Energy Management and Control of a Flywheel Storage System for Peak Shaving Applications," *IEEE Trans. Smart Grid*, vol. 12, no. 5, pp. 4195–4207, Sept. 2021.
- [6] Z. Taylor et al., "Customer-Side SCADA-Assisted Large Battery Operation Optimization for Distribution Feeder Peak Load Shaving," *IEEE Trans. Smart Grid*, vol. 10, no. 1, pp. 992–1004, Jan. 2019.
- [7] D. Kodaira et al., "Optimal Energy Storage System Operation for Peak Reduction in a Distribution Network Using a Prediction Interval," *IEEE Trans. Smart Grid*, vol. 11, no. 3, pp. 2208–2217, May 2020.
- [8] S. Chouhan et al., "DER optimization to determine optimum BESS charge/discharge schedule using Linear Programming," *Proc. IEEE Power and Energy Society General Meeting*, 2016, pp. 1–5.
- [9] Y. Guo et al., "Cooperative Peak Shaving and Voltage Regulation in Unbalanced Distribution Feeders," *IEEE Trans. Power Systems*, vol. 36, no. 6, pp. 5235–5244, Nov. 2021.
- [10] Spanish day-ahead electricity market. [Online]. Available: "https://www.esios.ree.es/es/?locale=en".
- [11] Gurobi Optimization, LLC, "Gurobi Optimizer Reference Manual," 2021. [Online]. Available: "http://www.gurobi.com".