

NetworldEurope
**Strategic Research and
Innovation Agenda 2022**

Table of Contents

1. Introduction and scope	05
2. ICT impact in society	07
3. EU and EC policies	09
4. The Smart Networks and Services Partnership	15
5. MS Initiatives	17
6. 6G vision	21
7. Technical challenges	25
7.1. System level aspects	25
7.2. System architecture	27
7.3. Software Technologies for Telecommunications	29
7.4. Security	30
7.5. Radio Technologies	32
7.6. Optical Networks	35
7.7. Non-terrestrial networks	37
7.8. Devices and Components	39
7.9. Future Emerging Technologies	41
8. Timeplan and deltas	43
8.1. System, Architecture and Software	43
8.2. Security	45
8.3. Radio and NTN	46
8.4. Optical	50
8.5. Devices and Components	51
9. Conclusion	53
10. References	55

Editors:

Rui Luis Aguiar, Instituto de Telecomunicações, Steering Board Chair of NetworldEurope
Didier Bourse, Nokia, Chair of Workprogram Design Team for 6G Infrastructure Association
Artur Hecker, Huawei, Chair of Vision Group of 6G Infrastructure Association
Jyrki Huusko, VTT, Vice-Chair of Expert Group of NetworldEurope
Ari Pouttu, University of Oulu, Chair of Expert Group of NetworldEurope

Graphic design & layout:

Sallamaari Syrjä, University of Oulu

This SRIA, based on the previous document from 2020 (SRIA 2020), has been developed with the effort and contributions from hundreds of experts across Europe, in a long and cooperative process, that benefited as well from contributions from different associations. The full list of technical editors and contributors is included inside the annex.





1. Introduction and scope

ICT (information and communication technologies) have become a pervasive and critical infrastructure for the modern society. Each one of us, and each economical sector, today relies on the existence of a mesh of interconnected computers to provide services, that are so ubiquitous that we individually do not reflect on their presence – it is an anecdotal fact that we only notice the importance of communications, and ICT technology in general, when it does not work: e.g. a large cyberattack, an area of very bad coverage of the cellular networks, the inter-continental flight without reliable data communications. All these are examples of moments that trigger our understanding on the importance of ICT to our personal lives. But the society in general, and the economy in particular, are also structurally dependent on ICT technologies: from the businesses that are directly dependent on ICT (e.g. stock exchange, social media, the ICT sector itself), over businesses whose efficiency strongly depends on ICT (e.g. logistics, production industry, agriculture – in fact all the sectors of economy) to seemingly ICT independent businesses as such (e.g., artisans), which, however, also use ICT in their internal systems (management by systems, internal ICT processes defining the company). Indeed, in advanced economies, essentially essential all professional interactions depend on ICT. Depending on the status of the existing infrastructure and country economy, the ICT impact may concentrate on the expansion of digitalisation with increasing socio-economic-digital inter-

actions (the situation in Europe), or the ICT impact can be mostly consumer-oriented and focused on the provision of electronic services for ultimate customers, leading to deep societal transformations (as ongoing in many developing countries).

NetworldEurope, the European Technology Platform for Communications and Services, is one of the institutions that aims to address the challenges brought by this increased intertwining of ICT and society. NetworldEurope brings together almost one thousand stakeholders of the area, ranging from SMEs to large industries, to the academia, and tries to engage with other relevant bodies in order to contribute to the establishment of consensual views about the future of this new connected Europe. In this context, NetworldEurope has worked with the 6G Infrastructure Association (6G IA), and has established liaisons with other European and international bodies (such as AIoTI, NESSI, ECSSO, ETSI, and CCSA¹) in order to build a Strategic Research and Innovation Agenda (SRIA) for communications and services. Given the essential role ICT takes in all society domains, such a SRIA cannot aim at completeness: there are always aspects that will be missing for specific sectors. Hence, we rather envision an establishment of a foundational basis for communications and services, on which other sectors can rely to plan their evolution and the deep transformational aspects that ICT will bring into the society at large.

¹ AIoTI - Alliance for IoT and Edge Computing Innovation; NESSI - European Technology Platform on Software, Services and Data; ECSSO - European Cyber Security Organisation; ETSI – European Telecommunications Standardization Institute ; CCSA – China Communications Standards Association

Part of the immediate impact of this effort will be reflected in the European research Work Programme of the Smart Networks and Services (SNS) Joint Undertaking (JU), driven by the European Commission and the 6G IA. But the contents of this SRIA can impact other European Work Programs, both at national level (where we see a widespread effort by European countries to fund national 6G initiatives) and at international level (either in Horizon Europe, e.g. Cluster 3 and Cluster 4 Work Programmes, or in other Joint Undertakings/Public-Private Partnerships besides SNS). As a deeply-technological vision on communication and services, NetworldEurope SRIA can be explored in different dimensions, in different technological and application domains. We will strive to provide support to the widespread acceptance of our technological roadmap and to link with stakeholders contributing to and sharing our vision.

This document is divided in two large and related parts. The main body (by simplification referred as “whitepaper”) consists of a simplified, higher level vision of our technological roadmap, with an additional deep section providing simplified metrics tables that identifies reference specifications for technology at different times (referred as nodes) and expected technological features associated with those nodes. A second part, the technical annex, provides a deeper reaching discussion on the technologies we envisage as key for the future, under the overall scope of ICT. The annex provides a discussion in ICT that, by necessity, had to be restricted to key dimensions from the point of view of the communications ecosystem. We have nine different chapters in this annex, which include:

The annex provides a discussion in ICT that, by necessity, had to be restricted to key dimensions from the point of view of the communications ecosystem. We have nine different chapters in this annex, which include:

- System Services aspects – overall system tradeoffs that need to be considered for the future, posing the stage for technology development
- System Architecture – analyzing the evolution of systems towards dynamically composed, multi-stakeholder environments, with an increasing softwarization and intelligence of the whole system, and the accompanying challenges.
- Network and Service security – discussing the paths on the increasingly relevant aspects of security in our infrastructure
- Software technologies – addressing the software related challenges of the ongoing network softwarization, the increasing system complexity, and the enabling of adaptive and customized services.
- Radio technology and Signal Processing – where the challenges and potential solutions perceived for the

future wireless (and mostly cellular) communications are discussed

- Optical networks – a critical component of the backbone (amongst other potentialities) and its perceived evolution is detailed in this chapter.
- Non-terrestrial networks and Systems – discusses the upcoming closer integration of 3D networks into the overall communication system
- Devices and Components – tackles the unavoidable challenges at the fundamental element level, which will constrain and limit all system developments.
- Future Emerging Technologies – is a final chapter discussing promising technologies that may bring structural changes across all the current communication concepts. Some of these technologies are already being researched, but have not yet a clear path (if ever) to the transformational impact it is expected by their wide adoption.

The diversity of technological domains required for future communication infrastructures underlines the relevance of these different chapters for many initiatives in European Research, from optics to satellite, and NetworldEurope will be actively engaged in discussing these views with all interested stakeholders. For simplification, in the whitepaper, we provide a summarized version of these chapters in Section 7. This section follows a previous overall 6G vision, presented in section 6, and is then complemented by a section on timeline and expected measurable key performance indicators, presented in section 8.

The initial part of the SRIA whitepaper presents the overall context driving our work, discussing the impact of ICT in the (future) society, the national and international innovation initiatives that are promoting and framing innovation in the area, and finally discuss the overall EC framework towards which this work should be a key contributor.

As a final comment on this introduction, it is worth highlighting the process of the lengthy development of the SRIA 2022. The SRIA 2022 discussion started during full pandemic period, with a public event in Lisbon, in November 2021, in the Visions For Future Communications Summit, starting with the previous SRIA 2020 [SRIA 2020] as a baseline. This was followed by a long period of discussion inside the Expert Group, where dozens of contributions were collected from multiple experts in Europe, and where different key innovation stakeholders were directly addressed to provide comments. In a final stage, a public consultation was issued, and its comments properly reflected inside the final text. Overall, this SRIA has been the result of the work of a set around 200 volunteers, coming from more than eighty entities. The NetworldEurope community is in debt to all for their selfless efforts.

2. ICT impact in society

In Europe, the entire ICT domain contributes significantly to the economy with about 6.3 % of total GDP, which corresponds to a market size of € 1130 billion. The importance of the ICT, health and automotive industries in terms of global R&D competitiveness is illustrated by the fact that the aggregated R&D of these three industries has more than doubled since 2010, and notably ICT services has tripled. As regards ranking of companies' investment levels, the ICT sector consistently occupies the top of the Scoreboard underlining the increasing digitalisation of the world economy. For 2020, all of the top five positions are in the digital sector.

This is also confirmed by findings of Eurostat. In particular, the communication systems and networks sector² (manufacturing, including communication equipment and telecommunications) is critical in this market with a strong contribution to the European economy (statistics from 2019, last full year before COVID-19):

- About 26.2 % (1.47 million employees) of ICT employment
- 27 % (€ 429 billion) of ICT market size
- 37 % (€ 11.6 billion) of R&D expenditure in Europe.

These numbers do not reflect the multiplication factor of advanced communications in the economy. The World Bank has shown that the availability of broadband access increases economic growth and employment³.

Non surprisingly, Smart Networks and Services (SNS) will thus empower several vertical domains. An indicative list includes Automotive, Healthcare and Wellness, Media and Entertainment, Smart manufacturing, Smart Agriculture and Agri-food, Transport and Logistics, Smart Cities and Communities, Utilities and Energy, Smart Buildings, Public Safety, Smart (Air)ports, Smart Water Management etc. Improving the operation of these sectors will assist in providing solutions for several Sustainable Development Goals (SDGs) as defined by the UN. Considering the Green Deal challenges, SNS will be even more critical. When considering the trends towards green industries, it may well be possible that ICT carbon costs may increase, but leading to much lower carbon emissions achieved by the efficiency gains achieved by incorporating more intelligent and interconnected approaches inside each industry. Gesi⁴ estimates that ICT has the potential to decrease global carbon emissions by about 20% by 2030 (an estimate very similar to the World Economic Forum, that estimates 15%).

Currently, industry has taken first important steps in digitalisation with the level of progress varying significantly between vertical sectors. The interest of industry in private cellular networks and hybrid networks is rapidly growing. Nevertheless, the **full digitisation of the industry is not yet achieved**. In standardisation activities most vertical sectors have not

² European Commission: *Digital Agenda Scoreboard – The EU ICT Sector and its R&D Performance. 2019,*

³ <http://documents.worldbank.org/curated/en/178701467988875888/pdf/102955-WP-Box394845B-PUBLIC-WDR16-BP-Exploring-the-Relationship-between-Broadband-and-Economic-Growth-Minges.pdf>.

⁴ SMART 2020 *Enabling the low-carbon economy in the information age*, <https://gesi.org/research/smart-2020-enabling-the-low-carbon-economy-in-the-information-age>

been thoroughly examined to identify key and meaningful requirements, and the associated ecosystems are still transitioning towards new methodologies. Even for those cases (e.g., Connected and Automated Mobility – CAM) where an extensive investigation has been made, the full support of the most advanced cases (i.e., implementation of critical services in an optimal autonomous driving mode in SAE⁵ levels 4 & 5) cannot be yet supported by existing network solutions without having a full integration of mobility data. Therefore, **the evolution of networks must take place hand in hand with the vertical industries.** With the increased pressure towards sustainability, with multiple metrics for the reduction of carbon emissions across all industries, it becomes increasingly important to develop total system (end-to-end, at service level) frameworks that may lead these digitalization drives to include upfront sustainability choices.

Ecosystems connected to digital platforms and market places create value for all members and have the potential to disrupt entire industries and show significant economic

and social impact. For example, the automation achievable by the Internet of Things across a broad range of sectors will lead to a potential economic impact in the range of \$4 trillion to \$11 trillion by 2025⁶. A fully functional Digital Single Market could contribute €415 billion per year to the European GDP⁷. Overall, the digitalisation of society is still in an early stage. For example, Europe's Digital Progress Report 2017⁸ points out that only 20 % of the companies in the EU28 countries are highly digitised and there are still many opportunities to be exploited especially by SMEs. Lately a report⁹ states that this number has only risen such that 54 % of large enterprises are highly digitised, against only 17 % of SMEs in 4 years. According to an Accenture study¹⁰ the economic opportunity from digitalisation in Europe is over € 4 billion in value per day.

Smart Networks and Services are of strategic importance as the enabler for basically all sectors in society and economy for jobs and economic growth, in a framework that creates a more sustainable future.



⁵ Society of Automotive Engineers

⁶ https://www.mckinsey.de/files/unlocking_the_potential_of_the_internet_of_things_full_report.pdf

⁷ EU Commission: Digital Single Market. Making the most of the digital opportunities in Europe. 2017, <https://ec.europa.eu/digital-single-market/en/policies/shaping-digital-single-market>

⁸ EU Commission: Europe's Digital Progress Report 2017. Commission Staff Working Document, SWD (2017) 160 final, <https://ec.europa.eu/transparency/regdoc/rep/10102/2017/EN/SWD-2017-160-F1-EN-MAIN-PART-27.PDF>

⁹ Digitising European Industry: an ambitious initiative whose success depends on the continued commitment of the EU, governments and businesses, European Court of Auditors, Jan 2021

¹⁰ ETNO: Accenture Study "Lead or Lose – A Vision for Europe's digital future". <https://etno.eu/digital2030/people-planet-prosperity>

3. EU and EC policies

A model emphasizing understanding more thoroughly the wider societal framework in ICT development was introduced in SRIA2020 [SRIA 2020]. This model is more timely than ever, and is worth to be re-iterated it here before discussing some recent policy outlines of the commission. Societal and business drivers will increasingly shape the Smart Networks and Services development, including Political, Economic, Social, Technological, Legal and Environmental (the PESTLE model) drivers as summarized in Figure 3-1, To ensure that the benefits of smart city services and urbanization are fully shared and inclusive, policies to manage urban growth need to ensure access to infrastructure and social services for all, focusing on the needs of the urban poor and other vulnerable groups for housing, education, health care, decent work and a safe environment. The rise of always-connected, omni-present systems, devices and sensors serving digital automation of critical processes will set high requirements for trustworthiness and resilience. The ubiquitous connectivity and contextual awareness of future Smart Networks and Services networks is expected to promote ICT accessibility and use for the social and economic development of people with specific needs, including indigenous people and people living in rural (and other low-density) areas. Thus, future Smart Networks and Services architecture fosters digital inclusion and accessibility unlocking also rural economic values and opportunities, in a sustainable development context.

High energy efficiency targeting reduced network energy consumption is a critical requirement for Smart Networks and Services. Combined with the optimization of choice, use, reuse and recycling of materials throughout the product life cycle enable reduced total cost of ownership, facilitates the extension of network connectivity to remote areas, and provides network access in a sustainable and more re-

source-efficient way. Furthermore, the efficiencies brought by extensive usage of SNS, will allow different industries, and the society in general, to decrease their carbon footprint. Currently the ICT sector accounts for 5-9% of electricity use and for around 3% of the global greenhouse emissions.

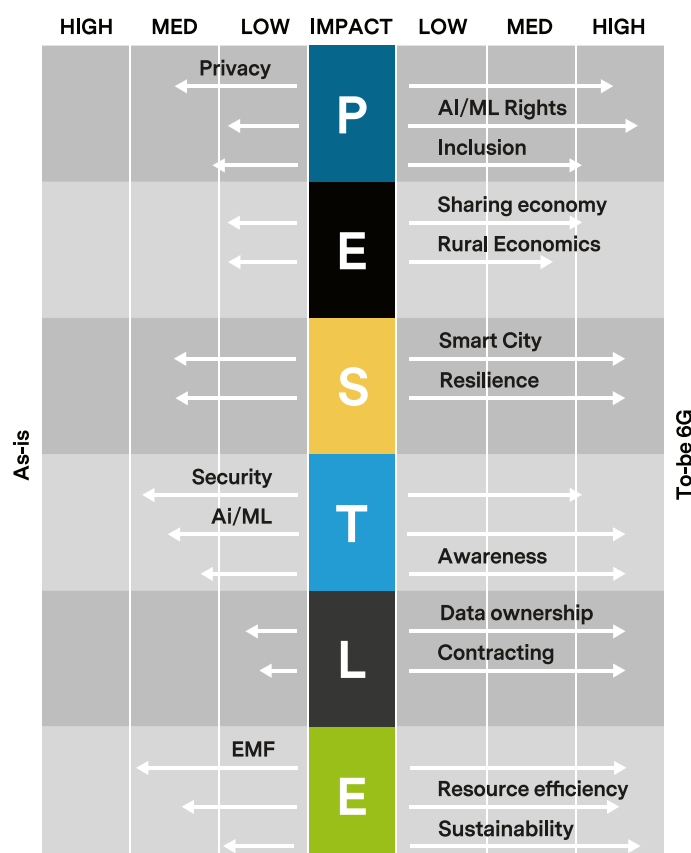

Figure 3-1. Future Networks and Services PESTLE (Political, Economic, Social, Technological, Legal and Environmental) analysis results highlight inclusion, sustainability, and transparency.

The EC estimates that the ICT footprint could increase to 14% of global emissions by 2040.

While operations in the lower frequency bands (below 4 GHz) currently used for wide area mobile communication networks will remain rather stable with MNO market dominance due to long-term spectrum licenses, there will be new bands that target super-efficient short-range networks, especially indoors, but also in outdoor city spaces. These networks will target verticals with specialized demand and can be deployed by different stakeholders opening the market to new players, new investments and new ecosystems. Building several overlapping ultra-dense networks becomes infeasible and will lead to different stakeholders deploying a network within a facility to serve multiple user groups and services. Via softwarization and virtualization of network functions and opening of interfaces, sharing economy concepts will be utilized not only at high platform business layers but widely in network connectivity and data context layers. Changes in the ownership of spectrum access rights, networks, network resources, facilities and customers will result in several different combinations depending on the situation as different facilities have different requirements and infrastructures. New incentives will arise including functioning of the society, in an interrelation between technology development and legal and regulatory frameworks.

Note that extensive research has already been conducted into possible health effects of exposure to many parts of the frequency spectrum including mobile phones and base stations. All reviews conducted so far have indicated that exposures below the limits recommended in the ICNIRP (2020) EMF guidelines^{11,12}, covering the full frequency range from 0-300 GHz, do not produce any known adverse health effect (UN WHO). Nevertheless, the introduction of novel Smart Networks and Services technologies, with increased reliance on dense mobile systems, will initiate the need to review the status of the science and identify gaps in knowledge needing further research to make better health risk assessments.

As a sharing economy, Smart Networks and Services ecosystem will introduce new stakeholder roles and change the existing roles resulting in a complex network. While the MNO market dominance continues in 5G, future connectivity solutions can be driven by new players in the market.

Stakeholders representing the different types of demands and needs originating from a variety of users that can be human or machine, and specific to the public sector or enterprises in different verticals are arising. Resources and assets needed to meet the versatile needs are then provided by different stakeholder roles providing physical infrastructure (facilities, sites), equipment (devices, networks), data (content, context), under the regulatory framework set by the policy makers as depicted in the outer quadrangle. Demands and resources are brought together through the matching/sharing stakeholder roles including different kinds of operators (local or vertical-specific operators, fixed operators, mobile network operators, satellite operators), resource brokers, and various service/application providers such as trust/security providers.

For instance, in the future SNS ecosystem, data ownership will remain an important source of value creation and control. Therefore, creating a system that transforms how data is collected, prioritized, and shared can create strong initial controversy, e.g., through raising serious privacy concerns over location and data (even if this information will be important for several technology proposals for efficient radio systems). Furthermore, how to do business with data itself becomes a key question. The contractual policies between the actors will define the relative strengths of information and data ownership between parties, for example how the trust and ownership of information and data will be established in the autonomous smart device and service entities of the future. The well-known GDPR¹³ is one example of such policies.

Overall, the (different) stakeholder roles in future networks are seen to change compared to the current mobile business ecosystem for public wide area networks and totally new roles will emerge. It is expected that especially the drivers listed in Figure 3-1 will fundamentally change the ecosystem and open new opportunities for different kind of stakeholders in 6G. The matching and sharing of resources to meet the demands will take place through new kind of activities to ensure inclusion, sustainability and transparency. Ultimately, the emergence and shape of the new 6G ecosystem are dependent on regulations which may promote or hinder the developments.

In the following, we will touch on a few of the most important EU level acts and policies that affect the Smart Networks

¹¹ ICNIRP Guidelines for Limiting Exposure to Electromagnetic Fields (100 KHz to 300 GHz), 2020

¹² International Commission on Non-Ionizing Radiation Protection (ICNIRP): March 2020, <https://www.icnirp.org/en/differences.html>. « Differences between the ICNIRP (2020) and previous guidelines »

¹³ General Data Protection Regulation

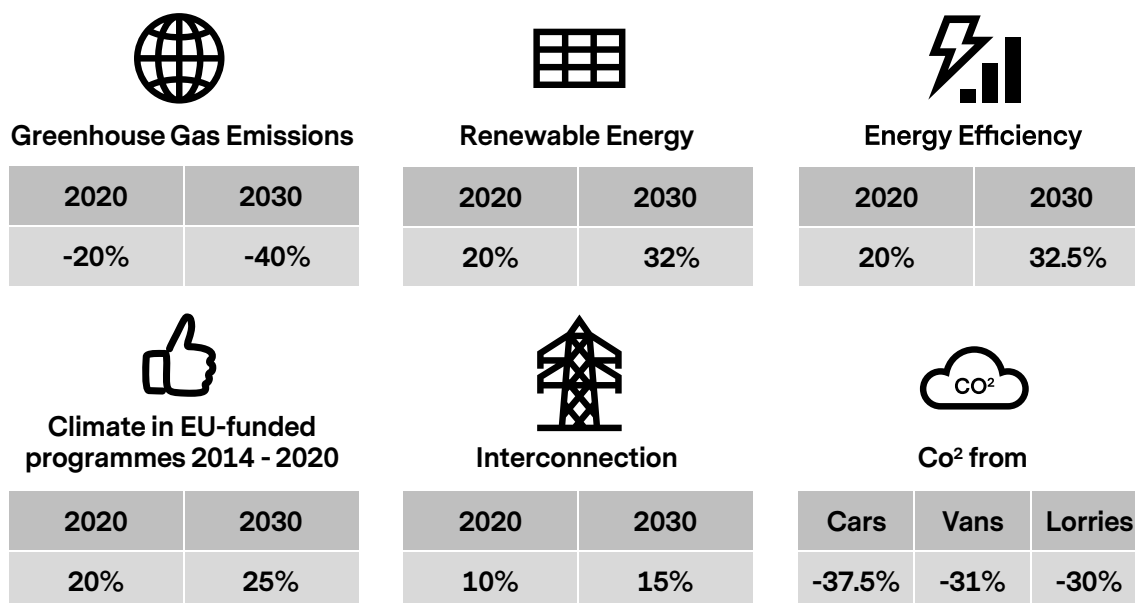

Figure 3-2. EU-Energy and Climate Targets 2018/2019 / Source: European Commission 2019¹⁴

and Services ambitions, and to which the SNS JU may provide solutions for supporting the policies.

Green Deal and REPowerEU - - The European Green Deal is effectively a response to challenges related to climate change [EC-EGD 2019]. It is also focused on a “new growth strategy that aims to transform the EU into a fair and prosperous society, with a modern, resource-efficient and competitive economy where there are no net emissions of greenhouse gases in 2050 and where economic growth is decoupled from resource use”. Smart Networks and Services will contribute significantly to the multidimensional goals of the Green Deal.

The technological revolution enabled by a myriad of technologies opened gates of green revolution transversal to all the facets of the economy and vertical domains. It is recognized that “new technologies, sustainable solutions and disruptive innovation are critical to achieve the objectives of the European Green Deal”. Smart Network and Services will enable disruptive innovation within industries, across sectors and across the single market. This will result in building new innovative value chains while increasing significantly the large-scale

The Smart Networks and Services Roadmap includes focus areas and synchronizes with the Green Deal timeline while

anticipating and reacting towards upcoming Climate Pact and other upcoming directives.

The success of the Green Deal will be measured by its implementation milestones and the impact achieved by the related contributions to each focus area [EC-EGD 2019]. During 2023-2027 time period, the **contribution of Smart Networks and Services will be multidimensional and synchronised with the timeline of the critical milestones and the legislation rollouts where appropriate and possible**. It will take all the elements of the value chains within the Partnership to make major parts of the Green Deal work.

In response to global energy market disruption caused by Russia’s invasion of Ukraine, the European Commission presented the **REPowerEU**¹⁵ Plan with two principal reasons **1) ending the EU’s dependence on Russian fossil fuels**, which are used as an economic and political weapon and cost European taxpayers nearly €100 billion per year, and **2) tackling the climate crisis**. This can be achieved through **energy savings, diversification of energy supplies, and accelerated roll-out of renewable energy** to replace fossil fuels in homes, industry and power generation.

In response to Green Deal and REPowerEU, the ICT systems by themselves need to implement energy aware designs.

¹⁴ “Fourth Report on the State of the Energy Union”, European Commission, 9 April, 2019, to be retrieved via: https://ec.europa.eu/commission/publications/4th-state-energy-union_en.

¹⁵ https://ec.europa.eu/info/strategy/priorities-2019-2024/european-green-deal/repowereu-affordable-secure-and-sustainable-energy-europe_en

This will start by **understanding the energy consumption** in end-to-end ICT services/networks. As the architecture and services of future networks will include more functions than mere communications functions, this understanding will help design mechanisms where **ICT systems themselves shall conserve energy** compared to current approaches. Furthermore, where applicable, ICT networks components can be **powered by renewable energy sources and/or energy harvesting** approaches which in part will provide resilience to the networks. Furthermore, the **efforts to engage in vertical industries** must be further intensified to allow for more efficient end-to-end services to be developed for vertical players. On a different dimension, **ICT systems will be able to synchronize** a multitude of individual micro-generators, increasing the technical solutions for power resilience, and improving overall peak energy consumption.

Chips Act¹⁶ – The challenges felt in the distribution chains for semiconductor chips, and the recent geopolitical changes, had led EU to develop a strategy to address semiconductor shortages and strengthen Europe’s technological leadership. The European Chips Act initiative plans to allocate 43 billion euros of public and private investments for chip technology development, to promote self-sufficiency and independence, given the large share of chips consumed in Europe (100 billion chips per year). The overall strategy aims to respond to the digital transformation already mentioned, with new markets for the chip industry emerging (e.g. automated cars, cloud, Internet of Things, connectivity, space, defence and supercomputers).

For SNS, the European Chips Act is essential for the development of the semiconductor solutions enabling **energy-efficient, high performance** communication systems. On the other hand, the developments brought by SNS in terms of infrastructure innovations and ecosystem transformations will open new markets for an European Chip ecosystem to thrive.

IPCEI¹⁷ – Important Projects of Common European Interest (IPCEI) are strategic instruments for the implementation of the European Union (EU) Industrial Strategy. They materialize in large-scale consortia aimed at Research and Development and the first industrial applications in strategic value chains. It is aimed at projects in any economic sector involving more than one Member State, with the potential to cre-

ate growth and employment, foster competitiveness and sustainability, and create value across the EU. In order to be eligible, projects must be co-financed by beneficiaries, ensure common benefits, and demonstrate their innovative capacity and high added value. IPCEIs make it possible to bring together knowledge, expertise, financial resources and economic actors throughout the Union, covering the whole range of critical industries in Europe.

SNS are critical to the IPCEI strategy, providing the **novel infrastructures required to more advanced value chains**, both in terms of communications and computation. IPCEIs can also be used to promote the development of an increasingly competitive ICT ecosystem in Europe.

Trustworthy AI¹⁸ – The requirements of Trustworthy AI are applicable to different stakeholders partaking in AI systems’ life cycle: developers, deployers and end-users, as well as the broader society. The below list of requirements is non-exhaustive and it includes systemic, individual and societal aspects: 1) Human agency and oversight – including fundamental rights, human agency and human oversight, 2) Technical robustness and safety – Including resilience to attack and security, fall back plan and general safety, accuracy, reliability and reproducibility, 3) Privacy and data governance – Including respect for privacy, quality and integrity of data, and access to data, 4) Transparency – including traceability, explainability and communication, 5) Diversity, non-discrimination and fairness – including the avoidance of unfair bias, accessibility and universal design, and stakeholder participation, 6) Societal and environmental well-being – including sustainability and environmental friendliness, social impact, society and democracy, and 7) Accountability – including auditability, minimisation and reporting of negative impact, trade-offs and redress.

As the complexity and dynamicity of control of future networks and services will increase beyond human capacity, the AI methods are widely considered in these contexts. Therefore, it appears that in cases where data related to humans or their context are handled, **privacy preserving AI/ML techniques** such as model based and/or distributed methods may be favored over other more classical methods.

¹⁶ https://ec.europa.eu/info/strategy/priorities-2019-2024/europe-fit-digital-age/european-chips-act_en

¹⁷ https://competition-policy.ec.europa.eu/state-aid/legislation/modernisation/ipcei_en

¹⁸ <https://digital-strategy.ec.europa.eu/en/library/ethics-guidelines-trustworthy-ai>
<https://digital-strategy.ec.europa.eu/en/policies/artificial-intelligence>
<https://digital-strategy.ec.europa.eu/en/policies/regulatory-framework-ai>



Cybersecurity Resiliency Act¹⁹ – Current ICT products are increasingly subject to successful cyberattacks, leading to explosive costs of cybercrime. Such products suffer from two major problems adding costs for users and the society: i) the low level of cybersecurity, reflected by widespread vulnerabilities; and ii) an insufficient understanding and access to information by users, preventing them from behaving adequately, using products in a secure manner. The cybersecurity resilience Act, as well as the overall efforts in security in Europe (e.g. the NIS directives) aims to ensure that manufacturers improve the security of products with digital elements since the design and development phase and

throughout the whole life cycle and ensure a coherent cybersecurity framework, enhancing the transparency of security properties of products with digital elements.

It is then essential that the communication infrastructure is able to cope with these requirements, providing the resiliency expectable for delivering a safe, easy to use, and reliable system.

¹⁹ <https://digital-strategy.ec.europa.eu/en/library/cyber-resilience-act>



4. The Smart Networks and Services Partnership

In the context of all these EC policies, the all-important communications infrastructure aspects were not forgotten. For developing a common policy for pushing European positioning, the Smart Networks and Services (SNS) Joint Undertaking was developed, establishing an alignment between European policies and industry. The SNS JU aimed to address the important policies mentioned above, but also to globally cover other important technical directions in Europe, established as:

- Europe's Digital Decade and Path to the Digital Decade Policy Programme²⁰
- EU Cybersecurity Act²¹ (Resilient Communication Privacy via Developing Proper Security Strategies).
- Data, Cloud and Edge Computing.
- High Performance Computing
- Internet of Things

The SNS Partnership targets reinforced European leadership in the development and deployment of next generation network technologies, connected devices and services, while accelerating the digitalisation of European industry and public administrations. It aims at positioning Europe as a lead market and positively impact the citizens quality of life, by supporting key Sustainable Development Goals (SDGs), boosting the European data economy, and contributing to European technological sovereignty in relevant critical supply chains, with a total of 900M€ of public investment and 900Me private funding²².

The first SNS Work Programme (WP2021-22) was targeted to progress towards the technological and business realization of the 6G vision developed notably under the 5G Infrastructure PPP and targeting massive digitalisation of societal and business processes through intelligent connectivity across the human, physical and digital world. The pre-definition of the WP2021-22 started in November 2020 and considered as key inputs the Networld 2020 SRIA 2020 "Smart Networks in the context of NGI" [SRIA 2020] and its related Annex II and the 5G-IA SNS Partnership Proposal. The definition of the WP2021-22 involved the 6G-IA Board Work Programme (WP) Sub-Group (SG) for the private side and EC Officers for the public side. The 6G-IA WP SG included specific 6G-IA Members and representatives from (SNS supporting Association) NetWorld2020, AIOTI, CISPE.Cloud and NESSI. The WP2021-22 was targeted to be as clever as possible to reach the strongest possible SNS Phase 1 Projects portfolio. The WP2021-22 definition process was also targeted to be as clear, transparent and endorsed (by the Community) as possible to ensure overall engagement and forthcoming submission of high-quality proposals with strong competition. The outcome of the definition was also targeted to serve as booster to develop the engagement from Community Members into SNS and 5G Infrastructure Association (new Members). The definition of the WP2021-22 spanned from November 2020 to November 2021, including many WP SG, WP SG-EC and EC-Member

²⁰ https://ec.europa.eu/info/strategy/priorities-2019-2024/europe-fit-digital-age/europes-digital-decade-digital-targets-2030_en

²¹ <https://digital-strategy.ec.europa.eu/en/policies/cybersecurity-act>

²² <https://digital-strategy.ec.europa.eu/en/policies/smart-networks-and-services-joint-undertaking>



States (States Representatives Group - SRG) meeting, to converge step by step the WP2021-22 definition. Specific Webinars were also organized with 5G-IA Members to interact on the WP2021-22 definition. The WP2021-22 was approved by the SNS Governing Board (GB) in December 2021 and the Call was open in January 2022.

After the WP2021-22 definition, and with 250M€ of funding already allocated, the WP2023-24 definition started in March 2022 and is completed by end 2022. The definition involved the 6G-IA Board / Work Programme (WP) Task Force (TF) for the private side and EC Officers for the public side. The 6G-IA / WP TF is including specific 6G-IA Board Members and representatives from (SNS supporting Association) NetworkEurope, AIOTI, PSCE and NESSI. The pre-definition considered as key inputs the Network 2020 SRIA 2020 and the technical components of the Strategic Research and Innovation Agenda

2022 (the annex of this SRIA). The definition also took into account the SNS Phase 1 Portfolio coverage with the first draft information available since the evaluation/selection and the SNS GB meeting organized in July 2022. Three 6G-IA Members Consultations have been organized in April-September 2022 period. Specific 6G-IA Webinars have been also organized to synchronize with 6G-IA Members on the progress of the WP definition and the analysis of the consultations answers. Many TF, TF-EC and EC-MSs (SRG) meeting have been organized since March 2022, to converge step by step the WP2023-24 definition. The WP2023-24 is targeted to be approved by the SNS GB in December 2022 and the Call to open in January 2023. It is planned that regular calls will be issued every year, with development processes similar to the one here discussed, with WPs targeted to be approved by the SNS Governing Board (GB) in December, followed by a call to open in the following January.

5. MS Initiatives

With the advent of the Smart Networks and Services, the research community started the 6G visioning, following the industrial views for the next generation networks and evolution of 5G systems. Various member states, who drafted and earlier published already national plans for 5G, are now turning their view towards 6G development, as well as strengthening the national research, development and monetization of 5G applications.

At the beginning of 2021, the EU Commission launched the first research projects targeting for the initial vision of system and technology enablers for 6G within the Horizon 2020 Framework Programme as a part of 5G Public Private Partnership (5G PPP). These projects will continue until the 2023-2024²³. For the continuity over the EU funding programs, at the end of the 2021 a new public / private joint undertaking program was agreed and started within the Horizon Europe Framework Programme, as discussed above.

In addition to the EU Commission funding, during the past year, some of the EU member states have started national initiatives, and funding allocations of research and development to 6G R&D. The national initiatives are focusing, especially, to support the evolution of 5G system and development of 5G application areas, but are also including support for more visionary research for 6G, including academic and industrial innovations.

National programs (such as “Sustainable Growth Program for Finland”²⁴) have promoted the development of 6G es-

pecially from the point of view of sustainable telecommunication and applications. As discussed, energy efficiency and sustainability are common themes for European research of future communication networks. Sustainability and greenness has been seen extremely important, not only in EU member states, but also globally (Europe, China, US, etc.). The aims include for example to enable energy efficiency, power savings and carbon neutrality in overall network system design principles, devices and software, and to enable extended life-cycle of system and energy efficient use of the mobile system resources and applications in different vertical application domains. The new innovations should be the most critical elements for green and sustainable development. The innovations for example of network openness, flexibility, security and performance, should be balanced with greenness and energy efficiency based on the actual market and use case requirements.

In the following we introduce shortly some of the started national initiatives to support 6G research and development. The information is based on publicly available information at the moment. Many other national initiatives are in different states of maturity, and during the next few years these programs will become widespread.

In Germany, the Federal Ministry of Education and Research (BMBF), launched the first German 6G research initiative already in April 2021 to support the national 6G research and development²⁵. Approximately 700M€ has been allocat-

²³ <https://5g-ppp.eu/5g-ppp-phase-3-6-projects/>

²⁴ https://julkaisut.valtioneuvosto.fi/bitstream/handle/10024/163363/VN_2021_69.pdf

²⁵ <https://www.bmbf.de/bmbf/shareddocs/pressemitteilungen/de/karliczek-6g-wird-unsere-kommu-ngstechnologie-von-ue-bermorgen.html>

ed for 6G R&D during the five years period until 2025. The main target for the first funding period is to create the basis for 6G innovation ecosystem in Germany. This includes for example establishing 6G research hubs to enable collaboration between the various research institutes and universities in preparation and carrying out the 6G mobile system research and optical fiber networks required by mobile network systems. In addition to hubs the initiative targets to establish an umbrella platform project to coordinate the activities and to support for liaison in Europe and globally as well as regulation and standardization.

France announced in July 2021 an initiative to support especially the 5G evolution, including future system research and development, boosting the national 5G and telecom network solution development, the support for the 5G use cases development for regional and industrial benefit and strengthening education²⁶. A total of 733,6 M€ of public funding was reserved for different activities for duration from 2022 to 2025. In addition to public funding, a private funding share of 969,6 M€ is expected, which enable the total of ~1700 M€ financing for 5G and 6G R&D&I. The allocated public funding for R&D during the period for future systems was 233 M€.

Finland has started the first 6G research program already in 2018 as a part of Finnish government's national spearhead program, with a national roadmap being currently under development. The 6G Flagship project have promoted the need for starting the 6G research activities from the early phases, not only nationally but also globally. The public funding for the Flagship ecosystem through Academy of Finland, Business Finland and EU for research and development until 2026 is approximately 250 M€ complemented with company funding. In addition to Academy of Finland funding for long term 6G system research, new initiatives for boosting 5G evolution and 6G research and development have been defined as joint activities between academic and research institutes and industry. The initial reservation for new 6G Bridge program by Business Finland and Ministry of Trade and Economics is approximately 25-30 M€ for first call in 2022²⁷. In addition for 6G research, additional public funding is reserved for research on quantum computing, and innovations for decarbonized and sustainable cities.

In Spain, alignments to support Spanish ecosystem for 5G / 6G with direct funding were made in 2021. The Council of Ministers approved in November 2021 more than 95 M€ to support 5G and 6G research for the first phase call of UNICO 6G R&D program. The funding support is targeted for research centres, public research foundations and Spanish public universities. In addition, it is planned to allocate funding from Recovery, Transformation and Resilience program for future communication technology research in upcoming years. In August 2022, the Spanish Government announced second phase of the UNICO 6G R&D program for years 2022-2023 including 116 M€ budget²⁸. The universities and public research centers are supported with 23 M€ especially for investments on infrastructures and equipment. In addition, 93 M€ budget is reserved for Spanish companies to develop and promote public-private collaboration and 5G evolution R&D projects in, e.g., photonics, machine learning, edge computing, RAN evolution, and privacy and security.

In addition, new funding schemes have been planned and are to be execute in various other member state countries during the upcoming years either as an extension of existing programs or as a new initiatives. For example in Austria additional funding have been released for "ICT of the Future" and "Production of the Future programs", to support excellence centers and research. In Netherlands, the topics have been identified to support economic growth, Dutch innovation and knowledge building, but official execution and budgeting has not been done yet by to date.

The positive assessments of different member states' recovery and resilience plans given by European Commission in 2021 included, e.g., support for roll-out of high-speed network infrastructures and 5G networks, as identified by the European 5G Observatory²⁹ (that provides updates on all market developments, including actions undertaken by the private and public sectors, in the field of 5G, according to its impact on the 5G Action Plan and other public policy objectives). For example, Italy's plans include fostering 1 Gbps connectivity across the country and support for extending the 5G coverage especially for 5G corridors

²⁶ https://www.economie.gouv.fr/files/files/directions_services/plan-de-relance/20210706_CP_5G.pdf

²⁷ <https://www.businessfinland.fi/49e334/globalassets/finnish-customers/news/calls/2022/call-for-ideas-20.6.2022-decarbonized-cities--6g-bridge---quantum-computing.pdf>

²⁸ https://www.lamoncloa.gob.es/serviciosdeprensa/notasprensa/asuntos-economicos/Paginas/2022/180822_ayudas-unico-6g.aspx

²⁹ <https://digital-strategy.ec.europa.eu/en/policies/5g-observatory>



along the roads with budget about €6,7 billion³⁰. Poland's RRF funding plan includes enabling the high-speed connectivity and 5G networks with €2.5 billion³¹. In addition, European Investment Bank has provided €130 million loan for Poland to build high speed fiber to home infrastructure³². In Swedish plan the €464 million RRF funding was targeted for accelerating the broadband network roll-out in sparsely populated areas³³. Based on the public information provided, it is hard to estimate what is the actual share of

infrastructure investments versus the support for R&D work from the total funds. During writing this whitepaper, it seems that the 6G R&D&I plans and roadmaps are not yet well realized in majority of member states. The actions for 5G and broadband deployment, however, support well the EU's 5G strategy in Digital Decade, aiming for full 5G deployment in all populated areas and Gigabit connectivity for all households by 2030³⁴.

³⁰ https://ec.europa.eu/info/system/files/italy-recovery-resilience-factsheet_en.pdf

³¹ https://ec.europa.eu/info/business-economy-euro/recovery-coronavirus/recovery-and-resilience-facility/recovery-and-resilience-plan-poland_en

³² <https://www.eib.org/en/press/all/2021-343-poland-eib-financing-of-pln-600-million-supports-the-roll-out-of-high-speed-internet-in-underserved-areas>

³³ https://ec.europa.eu/info/business-economy-euro/recovery-coronavirus/recovery-and-resilience-facility/recovery-and-resilience-plan-sweden_en

³⁴ <https://digital-strategy.ec.europa.eu/en/policies/5g-digital-decade>



6. 6G vision

Future SNS is expected to focus on an integrated ICT system able to address different types of applications that are only briefly envisaged today. Although there is no consensually established ideas on those new applications, commonly referred scenarios by industry include: telepresence, including surrogate robots and holography; shared cooperative environments, with high-resolution AV and VR for both gaming and professional applications; mood mediators, with automated environment monitoring and adaptation to the user; automated machines, including domestic robots and self-driving vehicles; co-bots, swarms of machines cooperating in both regular and hazardous environments; global reachability, covering the sea and skies; environment sensing and acting, covering global service intelligence provisioning with remote data collection; and body monitoring, specially to address an ageing society and internet of senses challenges. All these diverse scenarios can be looked at as ultimately addressing increasingly collaborative services³⁵, in increasingly larger areas, and with increasing reliability and (human verifiable) trust, providing the scope for the overall challenges that 6G systems will need to address, fulfilling the needs of the society in general.

With the general move towards collaborative services in the general ICT domain, the main problem is to overcome the traditional, but increasingly obsolete, separation of the entire compute-and-communicate infrastructure into separate domains (logic: network vs. application; business: telcos vs. clouds; silos: automotive vertical vs. manufacturing verti-

cal; ...) while providing better quality of service (more performance, less latency, adjustable, verifiable trustworthiness levels, etc). Chiefly, if the original Internet was about inter-networking, i.e., best effort bit transport between different networks, **future research must address inter-computing**, i.e., service execution between different systems, potentially deployed and operated between and by different stakeholders yet accounting for the respective service expectations within the whole chain. Given the diversity of both the involved stakeholders and of the provided services, this will likely imply the need to cover the whole end-to-end service provision. It will most probably require handling of end-to-end service execution aspects in dynamically composed environments, where individual components belong to different authorities, and might actually require, beyond classical technological performance indicators, to consider systemic indicators that reflect as well societal aspects.

This same trend applies to mobile communication systems, which have become a crucial part of the overall Internet ecosystem with the tremendous success of the mobile Internet (cf. smartphone revolution). Indeed, to shorten the paths (and latencies), to reduce general infrastructure involvement (better greenness, risk reduction) and to keep both operations and data local (better governance), these systems exhibit a unique positioning in terms of standardized omnipresence, best possible locality and realizations already involving both compute and networking resources. However, to achieve this target, their ongoing transformation from single authority domain, mere access

³⁵ *Creative industries (such as entertainment, theatre and artists) will be one of the sectors that will faster push the boundaries of this interplay between society and technology, and will require special attention and follow-up as drivers and thought precursors.*

networks to dynamically aggregated arbitrary service execution platforms must continue.

With more and more intelligence and computing power available per resource, in the future, the resources of these systems, configurable and orchestratable dynamically (i.e., also reprogrammable in runtime), do not have to be limited to particular predefined roles and can be used both to deploy/support new services (both network and end-user services) and to better match the requirements of services running over the infrastructure. With this however, *unlike 5G*, 6G will be not only more flexible in both its services and in its realization but will also exhibit much *higher dynamics*, in service types/loads but also in its own topology. With that higher dynamics and the seamless *co-existence of virtual and physical entities*, the currently physically separate islands of 5G and prior systems will often overlap in resources in 6G. This applies both to different domains of one single network (Terminal/RAN/Core), just as it applies to several networks (e.g. run by different MNOs) and to entirely different systems (mobile networks and clouds, mobile networks and NTN systems, etc).

Using the offered large variety of novel challenging ICT services, a massive number of devices will be served by these systems generating, exchanging and treating very large quantities of data. The infrastructure that supports society (IoT, cyber-physical systems) will be integrated with the Internet, which will help improve the effectiveness and efficiency of both. Useful insights can be generated based on the automatic analysis of all that data (e.g., using machine learning methods, ML, and artificial intelligence, AI). Beyond the analysis, AI/ML can also

be used to optimize deployment, adaptation, reconfiguration and other decisions or to create better-suited system modularizations and novel entities better suitable for the overall required processing. Hence, it is *paramount to approach AI/ML systemically to correctly assess the relevant trade-offs*: AI/ML instrumentations per se require massive data transfers, are computation-intensive and, ultimately, consume massive amounts of energy. *Relying on siloed solutions and dedicated implementations limits the usefulness of AI/ML, while it increases both its costs (resources) and the cybersecurity risks (attack surface)*.

The postulates above imply that the future network technology will have to support the general Internet economy and the particular **needs of the cyber-physical infrastructure**, like those encountered in the production industry, alike. It will have to work with virtual objects and remote objects, the density, distribution, longevity and interconnection of which in any area can vary a lot, including remote areas and/or the sea and skies or space orbits. It will then have to integrate local and remote objects and different connectivity modes seamlessly, with a diversity of connectivity technologies. It will have to handle its own constituting nodes and services of transient nature, which can disappear and reappear, possibly at a different location and in zero time, be multiplied and shrunk without notice, etc. At the same time, this future network will be expected to operate as a facility: it will be relied upon by private users, businesses, critical branches and governments. Therefore, it will have to be **resilient to failures, operational errors and security threats alike**, in a world, where autonomic operations for both services and infrastructures, and in particular AI/ML techniques, will be

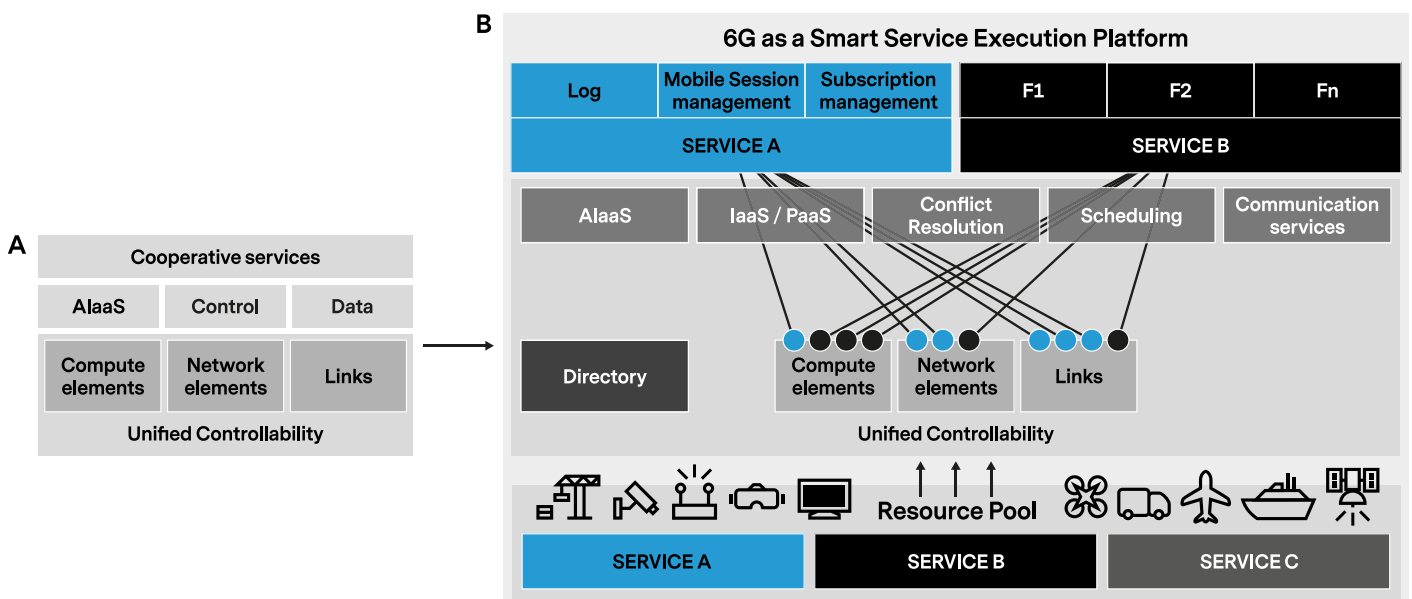

Figure 6 1: The general Smart Green Networks Concept and its projection to 6G

widely used. **Open standards** will be required, while governments will want to impose limits and regulations on the operations on all the data required to drive these new systems. In this context, overcoming the digital divide will be a key driver for technology evolution, and personal freedom and rights will need to be assured across all media.

Here, reliable and trusted flexible provisioning and elastic execution on a dynamic and changing resource pool emerge as key challenges for the future system architecture. Flexible provisioning refers to the generality of the infrastructure and its capability to onboard and execute essentially any ICT service. The generality of the infrastructure, as opposed to the reliance on service-dedicated components, is important to increase *infrastructure sustainability* over time and *degrees of freedom* for multiplexing gains. Execution elasticity refers to an efficient adaptation before, during and after the execution, i.e., in particular in runtime, and supports the selection of best suitable links, modules and more complex components, to preserve the expected service properties while limiting overprovisioning. In particular, elasticity, as the capability of adjusting resources used in service execution, is key to enable **truly green networking**, as it allows to redirect requests to resources with better ecological sustainability and to limit the overall resource footprint while preserving the service throughput. Given the resource mix, we must assume that elasticity and flexibility also apply to infrastructure resources, which can be as varied as data centers, edge nodes, flying platforms, or satellite computers. Hence, working with individual resources is limiting and not sustainable; rather, allocations and executions should refer to the resource pool as a whole. This in turn requires pervasive, resilient resource control, since without trust and reliability, the whole infrastructure cannot fulfill the expectations of either individual stakeholders (providers and consumers) or of the society at large.

Overall, we envision a Smart Green Network as a **programmable system based on a unifying controllability framework** spanning all resources a service/tenant is authorized to control, including from previously separate and heterogeneous domains, e.g., enterprise and telecom networks, virtual and physical, data centers and routers, satellites and terrestrial nodes, etc., covering a global network of networks (including the space domain). The unifying controllability framework will glue the disparate resource islands to one system of the tenant supporting smart flexible instantiation and adaptive, elastic and correct execution of any service on the resources (Figure 6-1). For 6G in particular, the resources will stem from all system players, typically from mobile network operators, but also from cloud providers, non-public network providers and might include terminals, where suitable. Interestingly, 6G will have to ar-

chitecturally embrace the fact that system resources used for service execution might, per se, be provided as services, i.e., that the service and its control in general cannot be limited to the strict boundaries of the authority domain of the service operator only nor to any particular layer. Rather, in 6G all system participants are potentially both resource providers and service consumers at once. In this situation, the properties of the service must be, in general, enforced regardless of (or even in spite of lacking) assurances at the resource layer.

Hence, the key challenges that the Unified Controllability layer must solve are: the aspects of control over multiple general-purpose, distributed, network control operating systems; the availability of powerful abstractions from resources to services; new naming schemes for virtualised resources; dynamic and automated discovery; structurally adaptive logical interconnection; multi-criteria routing in networks of different densities; (potentially intent-based) open APIs and highly configurable policies to control the resource and service access as well as dynamics; isolation of application's execution environments and performances; efficient scheduling of requests to resources; a high degree of automation and support of self-* principles (*self-driving networks*); secure and human-auditable methods to provide reliable and trusted infrastructures; and distributed yet trustworthy AL/ML instrumentations.

Overall, it is imperative to address different challenges to reach this vision:

- Sustainability – the infrastructure will need to be driven by sustainability considerations, both in its design, and in its applications, striving for implementations that will minimize the total number of units, protocols and interfaces, potentially allowing dynamic pooling of resources from diverse participating systems, devices and objects.
- Specialization – the infrastructure will need to be able to implement tailored features, while remaining flexible in terms of scalability, onboarding and function placement, offering programmable analytics and cooperative machine learning.
- High programmability – the infrastructure should offer programmability to the service layer through open interfaces, in technology-agnostic nodes potentially with cloud agnostic and micro-services approaches. Overall, it should integrate autonomics to enable self-organized, resilient programmability and elastic, correct service execution.
- Extreme connectivity – flexibly incorporating different radio technologies, including non-terrestrial networks, guaranteeing the interconnection of all types of sensing, communication and computing nodes, from low power to high-speed communications.

- Trustworthiness – providing embedded security and reliability into the whole infrastructure, for all stakeholders, with full coverage providing trusted and privacy-aware services.

Although this is a mid-term vision, it relies on already perceived trends in the industry. Many of the aforementioned aspects are currently being pursued in simpler forms inside telecom operators, which are pursuing network consolidation at the core (the integration of non-stand-

alone/standalone architectures and future B5G networks in a single seamless solution, with fully unified control, rating and billing functions) alongside the 5G deployment, given the expected gains in operation costs and improved network flexibility.

It should also be noticed that it is important that these directions are **accompanied by the appropriate economic and policy work** in future research to make way for the envisioned new services that go beyond current 5G.

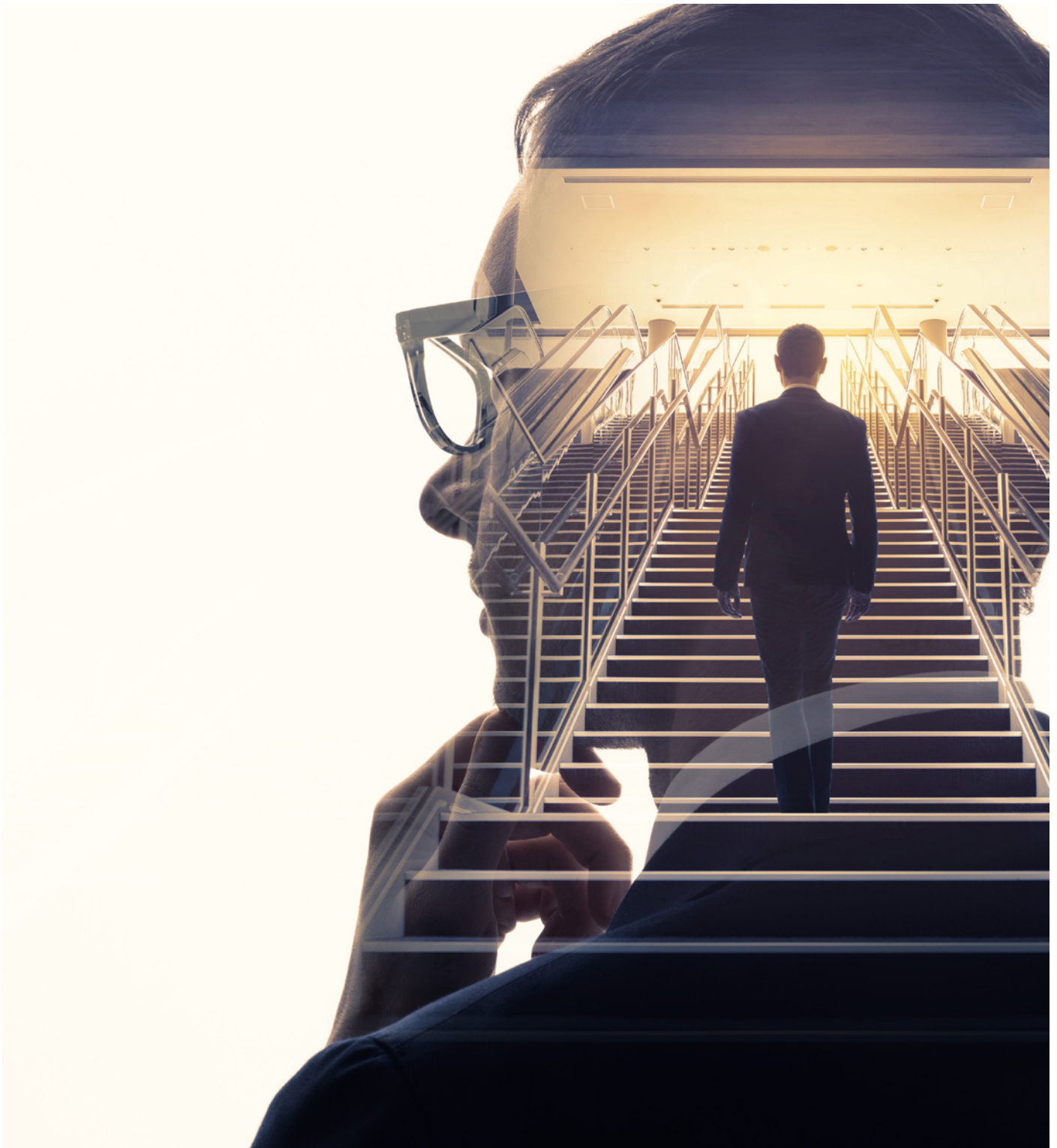

7. Technical challenges

Annex A provides an in-depth analysis of the different technical challenges that we envisaged for the upcoming future of 6G systems. Our analysis is broken in several technological domains:

- System level aspects – discussing overall considerations at system level
- System architecture – addressing overall 6G system considerations, at the network and computing levels.
- Software technologies – the challenges telecommunications poses to software development.
- Security – handling the perceived security challenges for the future.
- Radio Technologies – discusses the radio physical layer challenges
- Optical Networks – Covering the technologies centered on the backbone of the networks.
- Non-terrestrial networks – discussing satellite and similar technologies.
- Devices and Components – providing an overview of research challenges for the implementation technologies
- future emerging technologies - an overall coverage of technologies which may have deep impact in the future, but where we do not have yet clear industrial paths.

These technologies present several research challenges, which can be summarized in the following Sections. More detail information can be found in the Technical Annexes.

7.1. System level aspects

The Vision section already covers overall system perspectives. The technical chapter on System level aspects address some of the major transversal challenges deriving from this view. The evolution towards 6G has a couple of decisions to take with respect to the services that an SNS system intends to offer. One aspect is the range of possible ser-

vices that a 6G infrastructure will offer, which in essence is a reflection on the ecosystem that will realize 6G. The 6G infrastructure has to place itself somewhere on a spectrum from being a pure radio access system (unlikely, but perhaps conceivable) towards a fully integrated, general-purpose communication and service integration platform (the more ambitious, but promising, vision sponsored inside SNS and presented above). We conjecture that 6G will continue the trend set since 4G/5G to evolve from a primarily radio-oriented system towards a service-provisioning platform; it will be a goal of 6G research to find out how far to drive this development, considering tradeoffs like simplicity/complexity vs. new markets/revenue options.

Assuming that this trend will happen, **the notion of a “service” becomes much broader**. It is no longer a simple transporting-of-bits service, it is the execution of arbitrary software at arbitrary location, working on arbitrary data flows, as long as proper ownership of software and data flows, privacy safeguards, etc. are in place. To do so, the list of resources to manage becomes much wider; we need to think not only about typical communication subsystem resources (base stations, switches, routers, cables) but also about servers, storage, energy, etc. as well as about software, licenses, software and platform ownership and suitable deployment and operational models. This does complicate the picture considerably but opens the door to new technical approaches (e.g., overcoming resource silos like “edge cloud” vs. “core cloud” and thinking of a continuous set of resources instead). It further can also an entirely new type of services, e.g., a consistent interface to jointly sense data and act upon it by triggering actions in the real world.

Given the ensuing complexities of such a system, it raises the question whether the conventional system architecture ap-

proach – building an ever more complicated architecture with ever more capabilities – is indeed the right way to think about this. Instead, we postulate that it might be a promising idea to no longer think of “the” 6G system as large systems operated by a commercial entity, with simple network-user relationships, but rather to think of 6G systems, in the plural, as **systems that emerge out of the collaboration of individual networks or subsystems**. A possible option could be a recursive approach, where even two isolated handsets in communication with each other can be seen as the nucleus of a 6G network, running only those services that are inherently necessary to such a situation, covering both the communication and processing aspects. Put differently, we ask the question whether the past focus on the service interface between users and networks should be shifted towards the interface between different resource entities (including both network elements and computing nodes), with e.g. networks potentially ranging from being very simple or very complex, but still able to interact with each other in a useful and meaningful manner.

Doing that does require **rethinking a number of key service interfaces**. A key aspect will be an interface to create, manage, merge, split, extend, shrink, and destroy networks - from simple private networks to integrating private networks into public networks. Closely related to this interface is name-

space management and binding of names across different namespaces to form addresses, since information must be understood across networks. Of course, standard communication primitives need to be supported (e.g., unicast connection-oriented, congestion-controlled traffic like a TCP flow), but we also believe that it stands to reason to integrate other communication APIs deeper into a network, e.g., support for pub/sub traffic or message queues. Networks and devices will likely provide better introspection and inspection interfaces, e.g., to figure out their likely energy consumption when connecting to a particular network (as sustainability aspects will need to be considered intrinsically in the system). This should be complemented by APIs to support a wide range of cloud-style services, deploying latency- and location-aware microservice chains or network function chains inside a network at suitable locations, scaling them out or in as demanded by changes in the user population. The integration of sensing and actuation with each other (e.g., confirm that an action indeed has a desired effect by specifying how to verify that via expected sensing values) has already been mentioned; obviously, this needs to be integrated with storing and processing sensed/actuated information as well. In addition, we foresee a list of auxiliary services, negotiation and billing across multiple systems, location and time synchronization. Last, but not least, proper authentication, authorization, and accounting measures need to be in place.



7.2. System architecture

Distributed computing has taken a significant step forward with the development and utilization of the Internet in many industries, enabled through the overall TCP/IP suite, allowing for reaching any machine through a multi-tier architecture of autonomous systems (ASs). This basic principle, unchanged to this day, had to shoulder the burden of service routing, i.e., associating a request to an instance of a service name. While unchanged in principle, many things have evolved from this basic picture of Internet connectivity. In the following, we differentiate three aspects, namely the nature of communication over the Internet, the nature of services (and their relation) and the nature of provisioning in the serving endpoints that are being reached via the Internet.

The **nature of communication** over the Internet has changed significantly from the single-client-single-server model. Today, many such servers are hosted in large-scale data centres, exposing services via a data centre's internal routing mechanisms to the wider Internet – here, the client communicates to the data centre (over the Internet) rather than the server. In recent years, those PoPs have been moved closer to end users in an attempt to reduce costs (e.g., for inter-domain transfer) as well as latency (by being closer located to the relevant users), particularly for services such as over-the-top (OTT) video or social media. In essence, the nature of communication has moved from servers towards services, the realization of which, in turn, moves closer to the end-user.

When it comes to the **nature of services**, advances in software engineering broke up monolithic code blocks that served services with a single locus of consistency into smaller, independent pieces of cooperating microservices. Hence, the centralized client/server model has evolved into chains of (collaborative) transactions, with typical challenges like atomicity, combined resource management, and execution correctness of the transactions. This, in turn, has created the desire to extend the basic DNS+IP service routing in place today by network support for such chaining. This application-level trend goes hand-in-hand with the realization that a network cannot just limit itself to blindly forwarding packets; it needs to take an active role in, e.g., providing security (firewalls), assist in service routing (load balancing, redirecting), or traffic shaping. In consequence, this increasingly establishes application- and network-level services at an equal footing with utilizing the increasing in-network processing & computation capabilities. Overall, the nature of services has moved from monolithic services towards chains of collaborating microservices, at both application- and network-service level.

Along with changes in the nature of services, the third aspect are changes in the **nature of service provisioning**. While microservices (networking or application-level) can be provisioned directly on bare metal, virtualization has opened up new opportunities. The 5G community has realized the power of such added flexibility and enabled its 5G Core specifications to use service-based architecture (SBA), which adopts the micro-service model for realizing vertical industry specific control planes over a cloud-native infrastructure, within a so-called telco cloud. Service routing becomes key here for the dispatching of service request, e.g., to establish a data traffic session quickly to the right service instance in the data centre of the mobile operator. We observe that the nature of service provisioning has changed towards virtualization, for both application services and network services.

Accounting for these changes, multiple research themes, described in the technical annex in more detail, have been identified:

- **Pervasive Resilient Autonomic Resource Control** – Highly scalable, distributed, self-organizing routing protocol to provide in-band connectivity between all resources (zero-conf, zero-touch). Should work across a variety of different topologies (sparse, dense, changing), should support mobility and multi-homing of nodes and avoid to create traffic concentrations. Zero-conf and zero-touch are essential so that no configuration errors can break the connectivity, and that failures be auto-corrected. Solutions should notably feature progress as per time axis.
- **Separation of Controllability and Control** – Emergence of resource control as a separate domain from service-related control.
- **Compute-Interconnection (CIC) architectural frameworks to enable dataplane evolution that is economically and technically sustainable** – Incorporating architectural blueprints/frameworks with key roles and interfaces and economic models to show viability of new communication services
- **Runtime Compute Interconnection (resource) scheduling mechanisms that allow for broad**
- **CIC Operation and management (OAM) frameworks** – New OAM approaches that reconcile network and service operator policies while adhering to the commercial boundaries
- **Cross-flow and cross-endpoint data plane operations** – New mechanisms and protocols for cross-flow resource and timing (latency) control
- **Runtime Service Scheduling** – Protocols, algorithms, architectures and solutions for dynamic, runtime assignment of resources to tasks, such that the executing system handles each task successfully under that task's specific constraints while explicitly accounting for the re-

sources used by the solution per se and its novel, added constraints. Suitable proposals must achieve overall improvements in either resource usage (energy, capacity, etc) for the same throughput, or in terms of successful service throughput on an unchanged system. A particularly interesting approach is Runtime Compute Interconnection, meant to enrich modern communication systems with service semantics support, while continuing to adhere to net neutrality, hence leading to a service- and resource-efficient distribution of service tasks between resource endpoints.

- **Conflict Avoidance/ Resolution** – Protocols, algorithms, architectures and solutions for conflict avoidance or resolution facing concurrent, uncoordinated usage of resources, where the executing system strives to handle tasks successfully under that task's specific constraints, while the throughput of successfully executed critical tasks

(i.e., goodput) increases compared to a situation without the said mechanism in place on a fixed resource footprint.

- **Net zero (distributed) AI/ML** – Development of techniques, protocols and of a new architecture to promote the utilization of renewable energy resources (deployed and distributed all over the network, in the EU often available by energy regulation at the deep edge) for the learning process, so as to enable a reliable and robust learning, while relying on uncertain and time- varying energy resources, provide an efficient greenness-accuracy tradeoff and preserve privacy
- **Articulation of needs and provisions from the system to the user/applications** – Protocols, algorithms, architectures and solutions for user-to-system interface, i.e. exposing available resources and capabilities to the user applications and getting requirements from user applications explicitly or implicitly.



7.3. Software Technologies for Telecommunications

Software technologies are one of the fundamental enablers of telecommunication networks and they increasingly shape network architectures and capabilities. For example, 5G has adopted a service-based architecture (SBA) for its core functions providing flexibility and scalability. Standardized APIs (e.g. Network Exposure Function – NEF) have been introduced to provide applications with access to network resources and data in a controlled manner. Network slicing is a key concept of 5G, built on NFV, SDN, and the flexible SBA of the 5G core allowing the dynamic creation of multiple virtual end-to-end networks across the same physical infrastructure and offering network services tailored to specific use cases. DevOps approaches are applied to develop, integrate and deploy network services and software updates in an agile way. Open source software has become increasingly important to be witnessed for example in case of open software for the RAN³⁶. Open source has been proven to be a successful model allowing competitors to work together towards common platforms and de-facto standards not only in the telecommunication industry, but more general in software-intensive business ecosystems.

This network softwarization trend will continue. Future networks are envisioned to be built over heterogeneous federated "clouds", whose resources are homogeneously managed by a unified control and orchestration framework. This framework will form a computing continuum in which network functions and services will be created, deployed on demand, subsequently scaled, and seamlessly moved across the federated cloud infrastructure. This computing continuum will be able to optimize autonomously service performance and possibly off-load computation based on in-depth knowledge about the capabilities and resources exposed by the federated clouds. Service meshes and workloads will be based on stateless and serverless functions, microservices running in containers and virtual machines, as well as new advanced concepts that allow to optimize the use of specialized high performance resources including quantum computing resources. The concept of the computing continuum will impact architectures, interfaces, and the disaggregation of networks.

The network softwarization will also include the extensive use of artificial intelligence and machine learning models throughout the network and even at the radio level, while digital twins will potentially allow to simulate and test networks. Software-based capabilities of smart networks will

play a significant role for the commercial success of SNS ecosystems by addressing the digital needs for automation, adaptive and customized services, as well as the needs for agility in delivering complex, but reliable and trusted software and services.

The network softwarization requires research to get answers on questions such as: how to manage the lifecycle of AI/ML components and to assure access to and the trustworthiness of data required by AI/ML; how to guarantee that a self-adapting AI/ML component will behave within its design parameters; or how to engineer and integrate such a software-intensive system in general so that the growing system complexity can still be managed. It has to be explored how the software needs to be architected so that it is best adapted to the distributed 6G system and benefits most from the capabilities offered by the ICT continuum across devices, edge, and cloud. Even quantum computing resources will become available as part of the ICT continuum raising the question how to integrate and use these special compute resources in 6G. We also need to understand better how the non-functional requirements of sustainability, human-centricity, and resilience will impact the software architecture of 6G systems and applications.

The following software research themes have been identified and are further outlined in the technical annex sections:

- **AI-powered edge cloud compute continuum.** It explores the role of AI and federated learning to enable the edge for data protection, improved inference reliability, and supporting autonomous device clusters as well as the role of the network to aggregate and share insights from and among distributed IoT edge clusters. It also covers the use of AI-based cognitive capabilities to manage the distributed resources of the edge cloud compute continuum in a predictive and efficient way.
- **Automated and agile software engineering.** A key question in this area will be how future CI/CD pipelines and DevOps approaches will be designed to support a fully automated software lifecycle bundling software, AI components, APIs, and security into one development, delivery and deployment process as well as the enhanced integration with business processes on the network operator side. Also, low code platforms are considered as an easy-to-use development environment for applications and services.
- **Enablement of digital services.** This area covers approaches and software technologies supporting the creation and provisioning of SNS based services including services that can help to achieve sustainability goals of verticals.

³⁶ <https://www.o-ran.org/software>

- **Engineering complex, software-intensive, and self-adaptive SNS systems.** Managing the software complexity of a system of systems is becoming an increasingly challenging task and requires new operational concepts based on self-adaptation models and relying on AI algorithms as well as new SW engineering approaches for software intensive systems.
- **Software architectures.** This research theme explores software architectures and mechanisms that support offloading of computation-intensive tasks. Also, the use of quantum computing in the telecom context is covered in this theme: what are the telecom specific complex problems and algorithms suitable for quantum computing and how those algorithms can be implemented and integrated with classical computing.**Human centrality and digital trust.** SNS-based services should follow a service model that enhance human-centricity, meaning that services need to be trustworthy and ergonomic including easy to use and easy to access. In consequence, the development of software and services need to follow a “human-centricity-by-design” approach.
- **Digital twins in the SNS context.** Networking and the computing continuum will be important enablers providing the infrastructure and basic services required for the implementation of digital twins. Digital twins will be also used for monitoring and augmenting SNS systems.



7.4. Security

The Universal Declaration of Human Rights³⁷, Art.3 states that “Everyone has the right to life, liberty and the security of person”. By many aspects 6G Systems and Services cross security matters. This is actually the case, at least in European Fundamental Rights, for natural persons with respect to their personal data as stated in GDPR³⁸. Far beyond, 6G, following 5G enlarged scope, stands as a foundation of Digital Transformations involving natural, legal and up to national security issues. Whereas 6G is expected to be deployed in essential and critical sectors (private or public) of the society, Holistic security must be provided to mitigate inherent risks and ever growing number of Cyber-Attacks³⁹.

As a general principle, Systems & Services evolutions (Architectures, Technologies, Operations, Usages) mandates concomitant evolution of the Cybersecurity. 6G aims at being the enabler of an unprecedented number of use cases encompassing large diversity of architectures (Cellular, Cell-less, Edge, IoT, 3D, mesh, adhoc, Digital Twins, ...) with massive usage of AI (increasing the Attack Surface) and new technologies. If one consider the diversity of expectations up to Mission Critical but also Human-Centric, the Cybersecurity set of challenges can not be limited to classical hardening of some components or even obsolete perimetric and static approaches.

Last but not least, 6G is crossing multiples digital-related fields such as AI, Data, Micro electronic, Cloud, HPC, Quantum, Sustainability,...from security point of view, it results in a diversity of necessary regulations, knowledge sharing and transverse actions.

Two main aspects need to be consider in terms of security:

Intrinsic nature of Systems & Services: Holistic & Metamorphic

Basically inherited from the Middle-Age, the previous generations of cybersecurity suffer from more and more decoupling with the Systems & services evolutions. While security only makes sense from an End-to-End point of view, the challenge here is to deal with over-complex, highly distributed architectures. Multiplying fragmented multi-lateral, multi-layer, multi-party, (micro-)services “Black Boxes” perimeters with numerous interfaces and exchanges requires to re-think the **Holistic Distribution of Security** in all its phases (protection, detection, response).

³⁷ [https://undocs.org/en/A/RES/217\(III\)](https://undocs.org/en/A/RES/217(III))

³⁸ <https://eur-lex.europa.eu/legal-content/EN/TXT/PDF/?uri=CELEX:32016R0679&from=EN>

³⁹ <https://www.enisa.europa.eu/publications/telecom-security-incidents-2021>

Besides spatial distributions challenges, the transient nature of 6G Systems & Services configuration combinations is raising in turn a large set of security challenges. This requires holistic but also **adaptive security** fitting metamorphic properties of the systems. Among others, yet unsolved, challenges encompass, continuous/predictive assessment of security conditions, incremental certification, (Hybrid) AI-controlled time line of operations,...

Moving from Cloud-Native towards **AI-Native 6G** is opening a specific area for security. On the one hand the whole AI life cycle has to be secured. In particular, a direct consequence is to reinforce **data centric security** fueling 6G AI, together with xAI and assurance for models and behaviors predictability. On the other hand security will make full use of the AI power enabling enhanced 6G Cyber Threat Intelligence (i.e. OSINT for 6G), smart protection (from physical layer to services), Smart distributed and collaborative Attack Detection, Smart remediation and Response.

Security is horizontal and applicable to all Systems & Services parties. But one can wonder what is the global security level resulting from such heterogenous combination, made of more or less opaque (Black Boxes) segments. With well-known benefits (scalability, up-to-date features, consistency,...) of the XaaS paradigm, 6G should integrate **Security-as-a-Service** (SecaaS) provided by dedicated security vertical pure players.

Intrinsic needs diversity

6G is aiming at covering such a diversity of usages that it should be obvious that a “one size fit all” security model should either be too (dangerous, de facto trust in providers) basic or too (costly) high grade. It comes to the paradigm of **Differentiated Security (DiffSec)** Mimicking the multiple QoS-based attributes defining a Digital Service, Security Service Level Attribute (SSLA) should be one of them, based on Quality of Security (QoSec) criteria.

Once 6G will be capable to deliver DiffSec, users (Human or Machines) will be empowered to have a smart usage of Digital Services. Some challenges attached to this simple requirement consist in awareness of Services attributes through adhoc exposure, . request through security policies (ranging from Natural Language, Contextual specific syntax to Intent-based/semantic elicitation) and actual mapping into concrete combined provisioning some vertical applications may require formal proof).

The multiple 6G security challenges introduced above should be addressed through the following 7 areas, further detailed in the technical annex:

- **Architectures & Strategies** – Both Protection and Detection **End-to-End Security Distribution** (beyond pe-

rimetric), encompassing the evolving diversity of 6G architectures (Edge, 3D, Mesh,...). Integration of Security Services including **Security as a Service. Differentiated Security** architectures. **Cooperative Holistic Security** across domains, layers, stakeholders. As unavoidable weaknesses will remain, in particular at termination points, **Root of Trust** distribution and **BlackBoxes Tolerant** architectures.

- **Data Centric** – Data is key for privacy issues but also in control and management as fuel of AI-Native 6G. Beyond (lightweight) Post Quantum Encryption, processing of Data in 6G should be driven by dedicated approaches such as Sticky Policies (Data policy self-support), metadata, together with novel hardware architecture processing data according to their use policies.
- **Hardware and Physical layer** – 6G is bringing new hardware in the picture such as Intelligent Surfaces. More stringent requirements on Clocks for Time Sensitive Networks. Although 3D or Cell-less architectures changing the attack surface. From Trusted Execution Element on terminals, hardening of newly introduced 6G components (incl. side channel attacks), to jamming and eavesdropping attacks 6G security research landscape must embed systematically security considerations for Components and Physical layer. This should also cover the supply chain and any operations before entering in production.
- **Software & Virtualization** – Identified in 5G threat landscape as a main source of vulnerabilities Software —from Safe Source Code to the entire life cycle (incl. static/dynamic code analysis, OTA updates, Access Management & privileges) remain a strategic concern. Despite commonalities with the IT domains, 6G being more and more software predominant and disaggregated the question must be addressed with the complexity and authority fragmentation inherent to 6G. Virtualization tools and operations (OS, hyperware, APIs, slice controllers/orchestrators) are key to 6G and should participate to the Holistic approach with secured distributed interactions.
- **AI-based Operational Security** – the overall goal is the application of the Zero Touch paradigm to security. It results on multiple research direction for smart deployment of Security in such complex 6G architectures. Protection is already massively complex solving policies elicitation and combination. But Detection and response is even more challenging. 6G AI-Native should not only take benefit of atomic AI-based function (xDR) but being able to integrate it in a holistic way with all subsequent interactions between suppliers, providers, users. 6G AI-based security should also encompass Lawful Interception issues as well as Root cause analysis and identification.
- **Quantification, Evaluation** – There won't be trustworthiness if the Quantification and Evaluation are not there. As introduced above there is a need to define QoSec,

provide approaches to evaluate it and maintain this information available from service request to the decommissioning. Thus continuous assessment is a challenging objectives mixing somehow certification complexity with E2E perimeters and dynamicity. One should note that forensic, liabilities and major societal impacts depends on the future capability to evaluate the security quality (requires models, data lakes, potentially Digital Twins, friendly Hacking) and expose it to users,

- **Governance** – security is based on Standards, Open Source Communities all of it under multiple regulations. From education (Research Platforms as Cyber Range) to CTI sharing. Research actions may contribute to build a safe and secure ecosystem and make undoubtedly 6G acceptable from societal, industrial, strategic point of views.



7.5. Radio Technologies

Whereas 5G provides basic support for a multitude of services, incl. eMBB, mMTC, URLLC, etc, 6G networks are expected to deal with more challenging applications (e.g. holographic telepresence), and to meet significantly higher and more stringent requirements, such as Tbps data throughput, sub-ms air interface latency, extremely high reliability with packet error rate as low as 10^{-8} , everywhere mMTC, extreme energy efficiency, very high security, cm-level accuracy localization, etc.

One way forward to deal with these challenges is to consider more and higher electromagnetic spectrum such as THz, infrared and visible light. The centimeter and millimeter spectrum currently utilized for 5G and other legacy systems needs to be re-farmed and more efficiently reused, and co-existence issues among the relevant mobile or non-mobile systems should be carefully addressed. A scalable architecture will be beneficial to support both low and ultrahigh data rates, esp. for IoT applications. The radio building blocks (waveform, modulation and coding, non-orthogonal multiple access, full-duplex, massive MIMO (mMIMO), etc) need to be further developed to meet the 6G requirements and approach the theoretic limits. Among others, investigations are needed, e.g. for intelligent reflecting surfaces (IRS), integrated sensing and communications, random access for massive connections, wireless edge caching, etc. Moreover, machine learning (ML) and artificial intelligence (AI) as a tool has been successfully utilized in many applications. Yet, its application in radio interface design needs to be carefully studied. Specifically, for 6G air interface design, the following key radio enabling technologies should be researched, incl. (and further detailed in the technical annex).

Radio interference management

Three different aspects need to be considered.

- Spectrum re-farming and sharing:** In order to satisfy the high bandwidth demands of the upcoming 6G systems, it is crucial to reutilize the existing spectrum resources, e.g. jointly utilizing licensed and unlicensed spectra, using cognitive radio based solutions.
- Subnetwork:** In many applications, an access point controls and serves the needs of some devices next to each other, resulting in a subnetwork, and is itself a special device connected to an overlay public or private network. However, many open questions exist, e.g. spectrum allocation for subnetworks, co-existence with other subnetworks or overlay network, air interface design specific for subnetworks, integration of the subnetwork into the 5G/6G overlay-network w.r.t. architecture and protocols, etc.
- Wireless edge caching:** Caching can reduce network load and interferences, and consequently increase

spectral and energy efficiency, and decrease communication latency. But caching is usually implemented in core network, how to efficiently implement it for wireless (e.g. combining with multiuser MIMO physical layer schemes) needs to be studied.

Optical wireless communication (OWC)

Despite the small cell concept and new radio frequency spectrum allocation, the continued exponential growth in mobile traffic means that inevitably the radio frequency part of the electromagnetic spectrum may not become sufficient. Optical wireless communication (OWC) consists of infrared and visible light spectrum, which is about 2600 times the size of the entire RF spectrum of 300 GHz. Light communication complements radio frequency communications. Some further advantages of the OWC are: It can combine illumination and data communication. Off-the-shelf optical devices can be used. No multipath fading exists, etc. Main challenges include, e.g. interference mitigation to ensure that a UE can achieve high SINR; the OWC network development and integration into 6G.

mmWave and THz communication

THz (i.e. 0.1–10 THz, where 100–300 GHz are also considered as upper mmWave band) communication is envisioned as a key technology to satisfy the need for much higher data rate requirements, e.g. Tbps. As THz radio has different characteristics from the lower frequency radio, research needs to be done, from materials (e.g. graphene), to devices. Specifically for the new field “THz communication”, there exist many challenges, e.g. new THz channel models; new experimental platforms and testbeds; novel MAC protocols; modeling and mitigating non-linearities, phase noise; ADCs/DACs for tens of Giga samples/sec; efficient realizations of MIMO antenna arrays; regulation and standardization of THz bands; etc.

Massive MIMO including intelligent reflecting surfaces and cell-free massive MIMO

Massive MIMO (mMIMO) has been studied in the context of 5G. When moving to the THz band, antennas become even smaller and thousands of elements can be embedded. This leads to the so-called ultra-massive MIMO. Another way to improve wireless communication is to change propagation characteristics of the wireless channel, e.g. through intelligent reflecting surfaces (IRSs). The current cell-/network-centric approach can be changed to the user-centric one where the cluster serving a particular UE can be determined dynamically by choosing a subset of APs nearby. Its combination with mMIMO operations leads to the so-called cell-free mMIMO. In this concept, all APs are able to serve UEs cooperatively without any cell restrictions, and almost uniform services across the network can be offered. Yet, many

challenges remain, such as channel modeling of um-MIMO; feeding and control of each antenna element; real-time estimation and feedback of a large number of channel elements; space-time-frequency coding to exploit all diversities; etc.

Waveform, non-orthogonal multiple access and full-duplex

Non-orthogonal multiple access (NOMA) can result in larger achievable rates and provide means for grant-free access. Furthermore, advanced self-interference cancellation techniques can potentially double the spectral efficiency, and enable in-band full-duplex transceivers that offer a wide range of benefits, e.g., for relay, bidirectional communication, etc. In order to cope with 6G requirements and use cases, e.g. THz channel, Tbps throughput, extreme URLLC, integrated sensing and communication, etc., investigations are needed on advanced waveform and NOMA schemes, full-duplex schemes, incl. antenna and circuit design, esp. for MIMO and mMIMO.

Enhanced modulation and coding

Channel coding is regarded as one of the most complex blocks of the baseband transmission chain. Modern channel coding schemes such as Turbo, LDPC and Polar codes with excellent performance made their way into several communication standards, incl. 2G, 3G, 4G and 5G. Future new KPIs and use cases pose new requirements on codec design, so that research is needed on advanced channel coding and modulation schemes close to Shannon limit, for Tbps throughput, extreme reliability, extreme low-power consumption, as well as modulation with shaping loss removed, etc.

Integrated sensing and communication

For smart factory, V2X vulnerable road user discovery, etc, a cm-level positioning accuracy will be needed. With integrated positioning, sensing and communication, improved spectral and energy efficiency, and reduced latency become possible. Future wireless communication systems will have higher bandwidth, more antennas, denser network and D2D links, which will enable high-accuracy sensing, such as a radio positioning with cm-level accuracy. Radar can sense the environment and hence increase communication efficiency. However, the development of integrated sensing and communication poses several challenges, including integrated waveform design, integrated baseband and hardware design, sensing algorithms, multi-band sensing technology cooperation, fusion with other sensing technologies, computing power, etc.

Random access for massive connections

5G can support mMTC with some number of connected devices. For future networks, much more, i.e. thousands or mil-

lions of devices, will be connected, and very sporadic data will be generated and transmitted. How to coordinate such a network without spending the whole network resource and node energy needs to be carefully investigated.

Machine learning empowered physical layer

Machine learning (ML) is expected to redefine the classical approach in communication system design to achieve global optimization or performance improvement. 6G will be a large-scale and self-organized system that integrates terrestrial and non-terrestrial networks to provide seamless wire-

less connectivity everywhere. ML techniques may become important to improve the physical layer design and performance, in overall physical layer, channel learning, radio interface design, multi-antenna systems, and in-radio network AI computing. In addition, ML can be used to compensate losses caused by non-linear effects and other hardware impairments, optimize performance vs. resource trade-off, enhance the physical layer security by exploiting spectral and signal analysis to detect radio attacks, etc. Research is also needed on hardware architectures and solutions, e.g. for implementing real-time physical-layer ML algorithms.



7.6. Optical Networks

Within the next decade, the world will achieve an even higher level of digitalization, thus improving our quality of life and boosting the industrial productivity. We will enter a new era in which hundreds of billions of things, humans, connected vehicles, robots, drones, etc. will generate Zettabytes of digital information. Smart connectivity will be the foundation of this new digital world: Always available, intrinsically secure, flexibly scalable and upgradable, and environmentally friendly. A programmable network infrastructure will be the nervous system that the digital society, industry, and economy will heavily rely upon as it has been proved during the recent pandemic. Delivering the required performance, resilience, and security levels, while satisfying cost, energy efficiency and technology constraints, presents a formidable research challenge for the next decade. The challenges envisioned in the domain of optical networks are detailed in the annex, and this section highlights some of those challenges.

As a consequence, global data traffic in optical networks has been growing at a high and steady pace of $\times 2$ every 2-3 years over the past 15 years and there is no sign this will be slowing down. Hence networks need to urgently adapt, but not all segments will be equally affected. For the sake of efficiency and latency, data will be stored closer to the users of these data, hence metropolitan and edge optical networks will grow considerably faster than long-haul fiber networks. At the same time, cloud providers will continue to massively offload the public internet into their private intranets. Projections of future traffic predict required data rates of 10 Tb/s line interfaces and over 1 Pb/s for optical fibre systems by 2025, while optical interconnect capacities are expected to be aligned with the Ethernet roadmap of line interface speeds (~ 6.4 Tbit/s in 2030). Networks also need to provide headroom for unexpected traffic increases, as observed in several EU member states during the health crisis of 2020-2022.

New network architectures with edge clouds close to the end user and centralized clouds with flexible functional split are required. In order to enable this flexibility, **new switching paradigms are needed to connect real-time programmable optical devices in distributed architectures**. The steep learning curve in photonics integration will for example allow optical flow switching approaches, which were previously considered too costly and/or complex. This can pave the way to a new generation of switches with **optimized mix between optical and electronic processing functions**. They should be operating over multiple wavelength bands and spatial dimensions and have a smart network fabric relying on software programmability and slicing, addressing multiple protocol layers and network do-

main. This applies also to intra-DC applications, where new switching concepts mixing optical and electronic switching technologies could lead to higher performance and lower power consumption. Future switching architectures need to take the energy-efficiency of the switches itself, but also that of the network they are supporting, into account, in addition to ultra-fast switching speeds, the capability of switching on different levels of granularity and a high overall switching throughput. Another topic of interest would be **disaggregated switching platforms**.

While today's Internet is built on a best-effort traffic paradigm, an increasing number of applications require reliable end-to-end transmission with guaranteed throughput and bounded latency. Examples range from RAN transport over vehicular/robotic/industrial control to augmented/virtual/extended reality. Stringent network requirements also result from accurate positioning, navigation and timing (PNT) services. Future human-centric use cases such as the "Internet of senses" and holographic communication are expected to increase the demand for deterministic network behaviour even more. Application requirements are diverse and therefore a flexible quality-of-service (QoS) framework is necessary. While mechanisms exist to control throughput, latency, jitter and packet loss in packet-optical networks, they often provide statistical QoS only and do not guarantee a deterministic network behavior. Available timing signals rarely offer the necessary accuracy and/or reliability to allow precise time synchronization for mission critical applications. End-to-end services are often delivered over heterogeneous network infrastructure in which different QoS and traffic-engineering mechanisms are employed and need to interwork with each other. Novel solutions are needed which trade-off performance improvements against scalability limitations and implementation complexity.

Optical network automation is key to achieve operators' business goals and in supporting new complex services. Aspects related to automation must be developed in the areas of service deployment, network planning and overall network operation. Automation is critical in optical networks supporting increasing data rates given, for example, the complexity of modelling of physical impairments, or the large number of parameters and their interdependencies. Outcomes related to automation in single domains shall form the basis for more ambitious cross-domain automation (across technology layers or network segments). AI/ML solutions in support of network operations should be further developed beyond policy- / expert- / rule- based systems. Control and orchestration architectures should become increasingly modular, leveraging the flexibility of deployment in hybrid clouds, while relying

on open and standard data models, protocols, interfaces, and frameworks, including, for example, proven and mature open-source projects and initiatives.

The ever-increasing interconnectedness not only of people but also of devices starting from enormous power plants down to billions of IoT devices like sensors or appliances not only increases the dependence on the network infrastructure but also expand the threat surface and therefore the vulnerability of every individual and of society as a whole. Therefore, it is getting more important to better safeguard our network infrastructure against data leakage and unexpected service outages. The higher flexibility of optical networks, enabled through software-configurable network elements, also increases the vulnerability of such networks to various kinds of attacks and therefore security and **resilience aspects need to be part of the concepts** from the beginning, including the hardware and software layers of the network. More generally, the design of network equipment needs to employ modern security and reliability paradigms (security by design) and apply state-of-the-art software technology to foster efficient and secure implementation of increasingly complex network elements.

The focus on greener networks and processing systems, is becoming a top priority for our society. Solutions are mandatory to make both the power consumption and the footprint of the world-network infrastructures sustainable. As fibre optics and photonic devices are the key technologies underlying the worldwide telecommunication infrastructure, they will play a major role in reducing the total power consumption of the ICT. The foundation for cost- and energy-efficient systems with high reliability lies in the integration of multiple optical and electrical functions, scal-

ing down the number of high-speed interfaces between optics and electronics will reduce the power consumption of the network components. The ability to implement both high-bandwidth and lower-bandwidth interfaces in the same device, with on-the-fly software configurability, can help greatly in this regard.

Optics is an enabler for 6G, not only with respect to the new mobile transport network. Novel **optical interconnect technologies** will also play a key role in future advanced antenna systems, impacting their architectures. New advances in photonic integration open new opportunities to apply suitable combinations of optical, radiofrequency, and digital electronics to radio systems. These three application areas lead to a wide set of new challenges for optical technologies in radio access. Moreover, the evolution of **optical access technologies** has so far been driven primarily by Fiber-to-the-Home (FTTH) network architectures and services. The future evolution of optical access technologies and architectures will bring about further increased system capacities, highly flexible system and network reconfiguration, integration of optical access and RAN, meshed and resilient network topologies, co-existence of best effort and deterministic traffic, secured transmission over complex architectures, and more. Optical access technologies will be adapted to become suitable for diverse applications and network scenarios in public and private environments. They will use single- and multi-tenant business models, for vertical markets and industrial applications, for 5G and 6G mobile networks, and small intra-datacenter networks, taking advantage of their versatility of providing services in multipoint networks at the lowest possible cost while still meeting stringent QoS requirements.

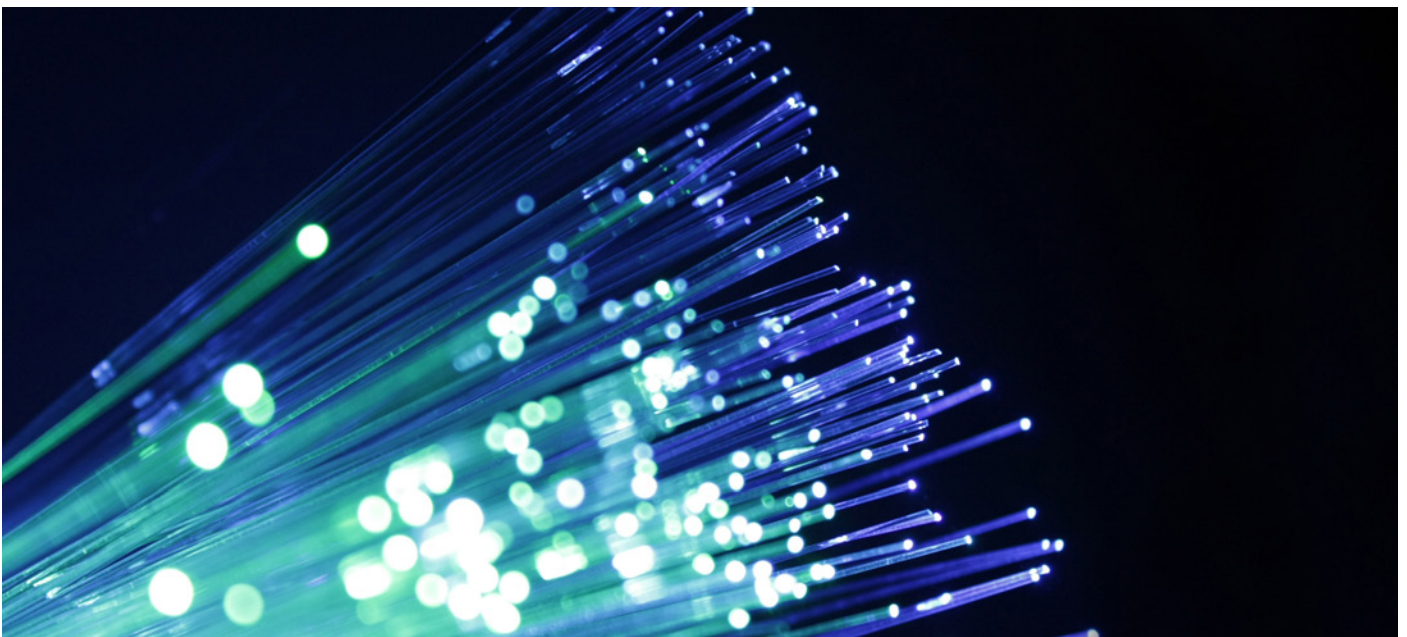

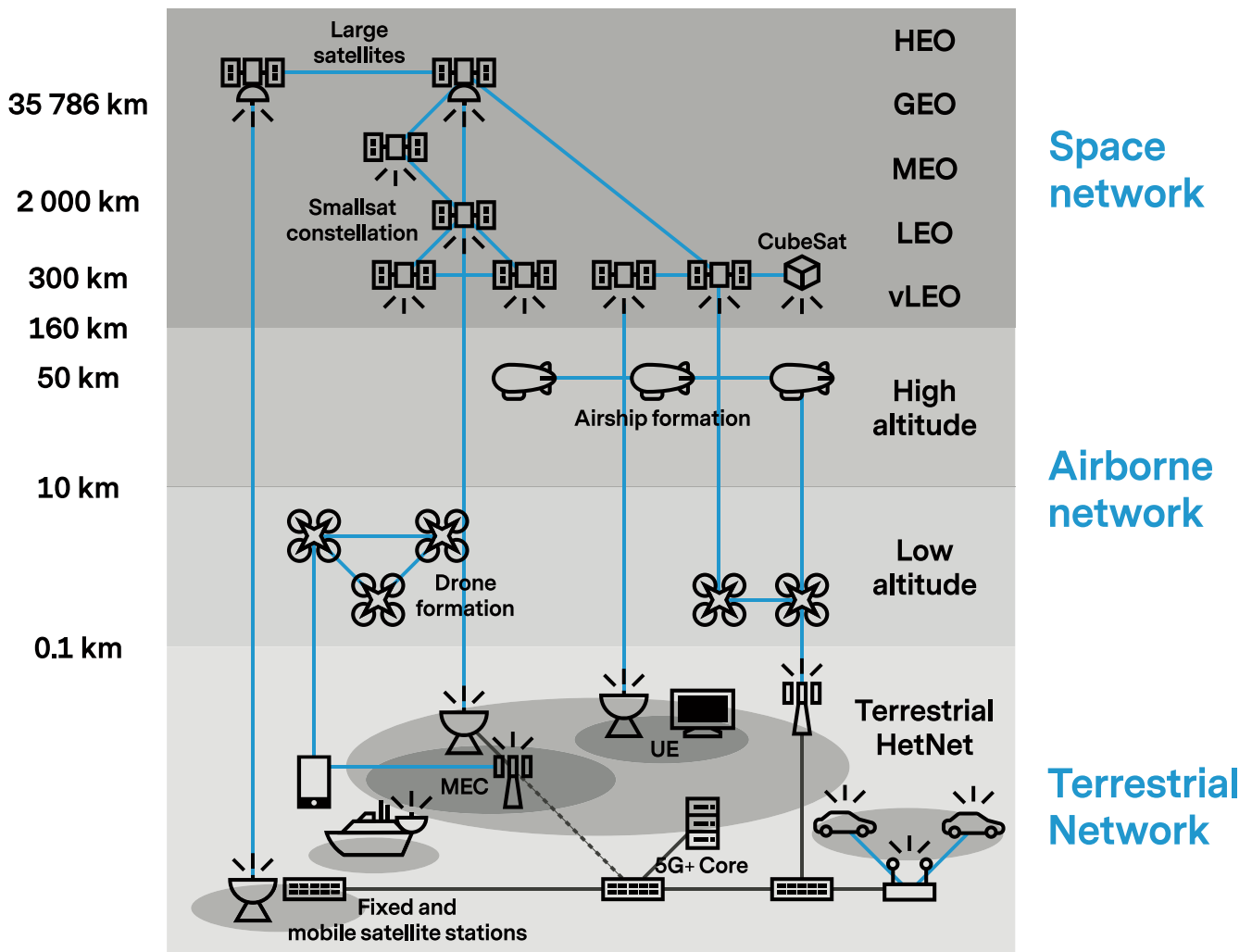
 Figure 7-1 – Network of networks⁴⁰

7.7. Non-terrestrial networks

5G has now rolled out in most developed countries in the World and we continue to see improvements and developments in the standards bodies. From 2021 to 2025 is the period in which non-terrestrial networks (NTN) including satellites will work towards 5G integration with terrestrial networks (TNs) and full commercial operation. Now is the time to start considering what techniques and technologies might feed into standardisation for 6G. The challenges posed for the NTN are here highlighted, and further discussed in the technical annex.

6G must be different from previous generations; as it must be designed to meet Global Challenges and at the same time to include the technology to support both cost-effective coverage and radically new innovative services. The

vision is of a **hybrid network of networks from short range and ultra-high capacity to widest coverage via a new space network dimension** (shown in Figure 7-1). NTN will become one of the key enablers to provide coverage and resilience in this 6G vision. NTN should be integrated from the start in 6G, rather than being bolted on as is the case with earlier generations. For satellites to play an integrated role in 5 and 6G, some **commonality of standards is required**. Until recently satellites remained outside mainstream standards bodies and had developed their own air interface standards — DVB-S which was originally based on video broadcast. More recently and seeing the advantages of integration, satellites have joined the 3GPP standards group responsible for 5G and now 6G standards. There is thus a pathway to full integration with the period to 2025 used to getting 5G

⁴⁰ M. Höyhty, M. Corici, S. Covaci and M. Guta, “5G and beyond for new space: Vision and research challenges,” ICSSC-2019, pp. 1-16, doi: 10.1049/cp.2019.1236

and satellite established and the period up until 2030 having satellite established as a unified part of 6G.

Within Non-Terrestrial Networks (NTN), satellites remain key and today's satellite communication systems have expanded from GEO's to include MEO's for regional coverage which operate with digital payloads including multiple beam antennas to provide frequency reuse and very high throughputs, approaching a Terabit/s. A major innovation has been the emergence of massive constellations of LEO satellites (Starlink and OneWeb) also offering very high throughput and additionally low latency matching the demands of 5G and potentially 6G services. For 6G we will need new and advanced techniques that enable deeper integration between satellite and terrestrial networks which are seamless from a user perspective, moving from satellite to terrestrial coverage. With the introduction of large LEO satellite constellations with high mobility this introduces new challenges ranging from intelligent and dynamic spectrum sharing to seamless handover and maintenance of QoS.

Next generations of these constellations will use optical intersatellite links (ISL's) and higher frequency bands above Ka band; Q/V and up to optical for feeder links as well as ISL's. In addition, the next generation of GEO and LEO satellites will include regenerative payloads to provide improved connectivity. Most applications are currently for backhaul or direct to fixed terminals. However, some companies are experimenting with direct to HH -UT's operating in the mobile bands (ASTmobile and Lynk), The latter require major technology advances and are likely to be a longer-term realization.

The role of satellites has traditionally been to provide coverage into regions not economic for terrestrial infrastructure and to provide resilient backup to terrestrial services. Today, NTN provides not only ubiquity and resilience, but also flexibility, efficiency, service continuity, and fast and low-cost global coverage (e.g., for IoT application). As terrestrial networks pursue lower latency service offerings, satellite constellations at very low altitude (vLEO) with Inter Satellite Links (ISL's) offer comparable and even lower latency for longer links. Thus, these systems are of interest for 5G and now inclusion in 6G. Due to restricted spectrum and satellite power, capacities have in the past been limited and hence more expensive than terrestrial. However today using frequency reuse, dynamic resource allocation and onboard processing both GEO and LEO satellites have increased to circa 1 Terabit/s and the costs of the space system have drastically reduced.

The key role of NTNs is in ubiquitous coverage, resilience, flexibility, efficiency, and continuity. However,

they are also essential in enabling other critical services such as earth resources, positioning-navigation and timing (PNT) and for continuous control and connectivity to aerial devices (UAV's) and maritime vehicles. The ultrahigh capacities needed for some 6G services will only be available on short range terrestrial connections using TeraHertz links in urban areas. A range of 6G services will be required by users travelling out of these areas and thus the pathway to 100% coverage can only be economically provided by satellite. Satellite will also be used to backhaul mobile cells in rural and remote areas or/and to provide a backup resilience. Of course, connection to ships and aircraft will necessitate satellite backhaul. Connection to premises or events can be provided quickly by satellite via small antennas.

In addition to the above it will be seen that the addition of the extra dimension of space to create a 3D network is implicit in the 6G vision and this is where satellites fit into a broader picture. As shown in Figure 7-1 this leads to the concept of a multi-layer network which adds satellites in GEO, MEO and LEO to lower altitude HAPS and even lower aerial devices such as drones. The network architecture connecting these components will be service dependent as some architectures will better suit the requirements of specific services. The network functions can also be distributed amongst the entities to optimise performance. In all cases we will have a highly integrated E2E cross network system. Also considerations regarding energy and spectrum efficiency, location sensing, carrier aggregation and advanced antenna arrays are being tackled. In other areas advances in software defined radio (SDR) and digital processing will contribute to more flexibility in radio access and in core networks. Security across the whole system will be critical and will be embedded in the design. This will require the use of intelligent firewalls, context-aware domain level protection, and advanced cryptography supported by cloud quantum computing. These and other innovations will feed into the base definitions for 6G.

As discussed in the technical annex, key Challenges for satellites in 6G will include: Unified T/NTN architecture; Full network integration of all layers in the 3D reconfigurable (SDN) Network; Direct connectivity to smart phones, outdoor and light indoor and in vehicle; Ultra Low Latency support for vertical sectors; Merging networking and computing; Integrated and flexible Air Interface for multi services; Ultra-accuracy of positioning and timing; Embedding AI in network and RAN; Providing Security across the network- elements; A new IP for space networks; New spectrum and sharing across the network components; Supporting massive IoT; and solving the problem of massive antennas in space.

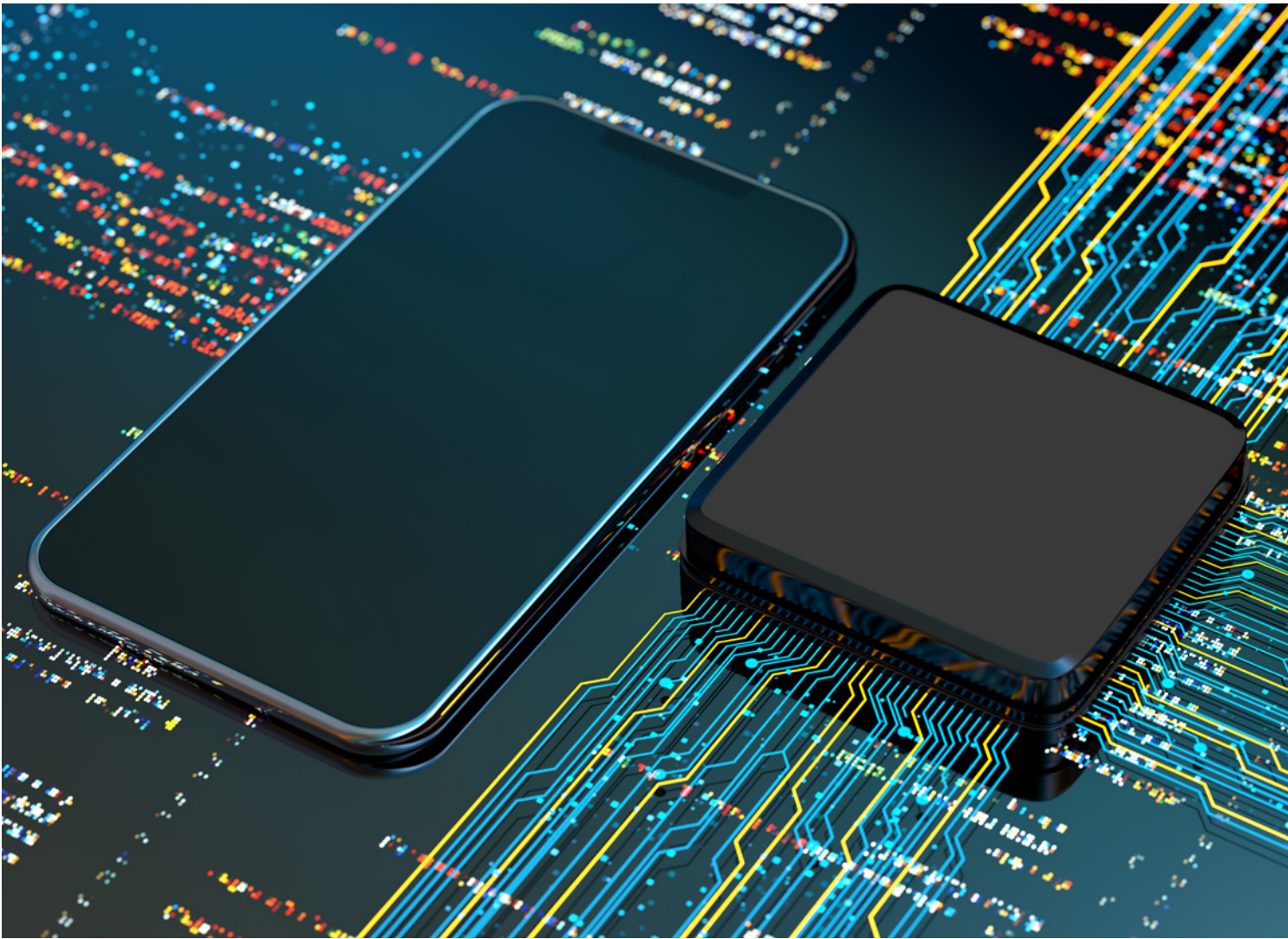

7.8. Devices and Components

Wired and wireless networks are in constant evolution with the goal of addressing all relevant societal challenges, support the digitization of the industry, improve communications devices, support new applications, support the “more AI” trend, To reach these goals, we expect future networks to support very low to very high throughputs, increase area coverage, reduce latencies, improve reliabilities, integrate artificial intelligence, support an ever-larger number of verticals.

Before delving in specific technological domains, it is crucial to consider power consumption, which is a generic problem. We are entering an era with antagonistic requirements. On the one hand, the number of devices is exploding, throughput requirements are growing for many devices and are certainly growing for the infrastructure equipments. On the other hand, the pressure to reduce the carbon footprint of the communication networks (including human and non-human user devices) has never been so high and will more than likely keep growing. Therefore, reducing the power consumption per end-to-end transmitted bit (W/bit) or per end-to-end transmitted bit and meter (W/bit/m) applies to

all areas of communications. Significant efforts are needed in this direction and the increased “cloudification” that we witness today must be exercised with caution in this context.

The requirements on the components (e.g. chips, antennas, ...) and devices (“device” is used with the meaning of “user device” in the broad sense but not “transistor device”) are very broad: they cover all aspects of infrastructure and human and non-human user device hardware and software. The following text describes the requirements of the key technological areas of future smart networks. They include different parts of the hardware including radio transceiver hardware, computing and storage, optical hardware, security and IoT. Research challenges, detailed in the technical annex, are summarized here.

Sub-10 GHz radios

Power amplifier with high output power and high power (added) efficiency are needed. A promising approach is to utilize GaN amplifiers integrated with CMOS circuits. Higher signal purity (EVM) is also needed which can be achieved by bet-

ter circuit architectures (more linear circuits, lower phase noise, better front-end modules (filters, duplexers, switches, etc...)) but also by moving the digital to IF and even RF, this requiring progress towards ADCs with higher resolutions and bandwidths ($\gg 12$ bits, up to 1 Gsps). Wider bandwidths, more aggregated channels and bands is the major way to increase throughput since spectral efficiency increase by higher order constellations or higher order MIMO starts to saturate.

Mm-wave and sub-THz radios

Requirements for this frequency range follow the same trends as sub-10GHz but the approaches are significantly different because the circuits are very different, and the semiconductor technologies are also different for the higher bands. CMOS is preferred for high volumes but not the most scaled nodes. Power amplifier with high output power and high power (added) efficiency will be possible by integrating III-V (e.g. InP) amplifiers with CMOS. Low phase noise PLLs are much more difficult to realize and this is a key limiting factor to high spectral efficiencies. DACs and ADCs with moderate resolutions and large bandwidths are needed (>8 bits, $\gg 1$ Gsps). Chips and antennas must be co-designed. A lot of innovation is expected with meta-materials, advanced PCB technologies with combinations of microstrip technologies and substrate integrated waveguide, on-chip antennas for e.g. small IoT devices.

Extreme low-power and zero-power radios

A well-known solution is wake-up radios which is already appearing in some standards. A significant improvement could be obtained with energy scavenging including thermoelectric, photovoltaic, piezoelectric, RF or wireless, wind and vibration energy harvesting. Yet another interesting approach is wireless power transfer technologies although efficiency is usually low.

In-band full-duplex technologies

In-band full-duplex can increase network capacity and reduce latencies because of the simultaneous two-way transmission. Isolation higher than 100dB is challenging and is needed in some cases, requiring a mix of antenna, RF, analog and digital co-design. Similar performances are also needed for mono-static radar modes (sensing).

Optical components and building blocks

A general trend is to use more and more coherent optics for higher efficiencies and larger throughputs. For efficient, low cost and low form-factors, a key research area is monolithic integration of photonic and electronic components. Integrating narrow linewidth laser sources and optical phase locked loops is also needed for complete system integration. Broadband signal generation and detection beyond CMOS is a general research trend. Convergence of optical and wireless will lead to innovative fronthaul archi-

tectures such as wide bandwidth Radio-over-Fiber and sigma-delta Radio-over-Fiber. Optically assisted RF is another research area for e.g. true-time-delay beamforming, frequency generation in the THz domain, time-interleaved ADCs and microwav photonic circuits in general.

CMOS scaling towards 1nm (A10) and beyond (A7, A5, ...)

CMOS scaling will continue, following Moore's law, but with new transistor topologies and lithography. Extreme UV (EUV) lithography will move to multi-patterning EUV lithography and later to high-numerical-aperture EUV lithography to support patterning of the 1nm node. In parallel, new transistor architectures will be needed. It is expected that the current FinFET architecture will be replaced by the Nanosheet, the Forksheet and eventually the Complementary FET to enter the 1nm and below nodes. Improvements are also needed in the backend of line and 3D stacking. All these technological improvements will, at a higher level, support larger functionalities in ASIC, FPGA, CPU and GPU.

Larger memories

New memory technologies are needed to enter the zettabyte and yottabyte eras by the end of the decade and to enable new and more powerful AI/ML architectures. All levels of the memory hierarchy (from registers and L1 cache to external DRAM) need further research: novel DRAM, 3D stacking and magnetic random access memories (MRAM) technologies as SRAM replacements. In particular, promising MRAM approaches are spin-transfer torque (STT)-MRAM, spin-orbit torque (SOT)-MRAM and voltage controlled magnetic anisotropy (VCMA)-MRAM). Orders of magnitude improvements (in both capacity and lifetime) are needed in storage-class memories for data servers, long-term archiving. DNA storage is an emerging and emerging technology for storage. Compute-in-Memory is a paradigm shift for AI/ML.

Security features in hardware

Critical areas for secure hardware are long-term security maintenance (how to build systems that self-maintain their security for 20+ years with minimal maintenance cost) and fail-security and survivability under major attacks (exploring new HW mechanisms that allow graceful degradation under attacks while supporting automated recovery of security while the system maintains its critical services).

IoT devices

Most of the research areas mentioned above also apply to IoT devices. A general constraint for IoT devices is the capability to integrate the complete device in a System-on-a-Chip (SoC) for power and cost performance. This can often be challenging (mix of technologies) and can be seen as a strength and opportunity for European chip manufacturers.

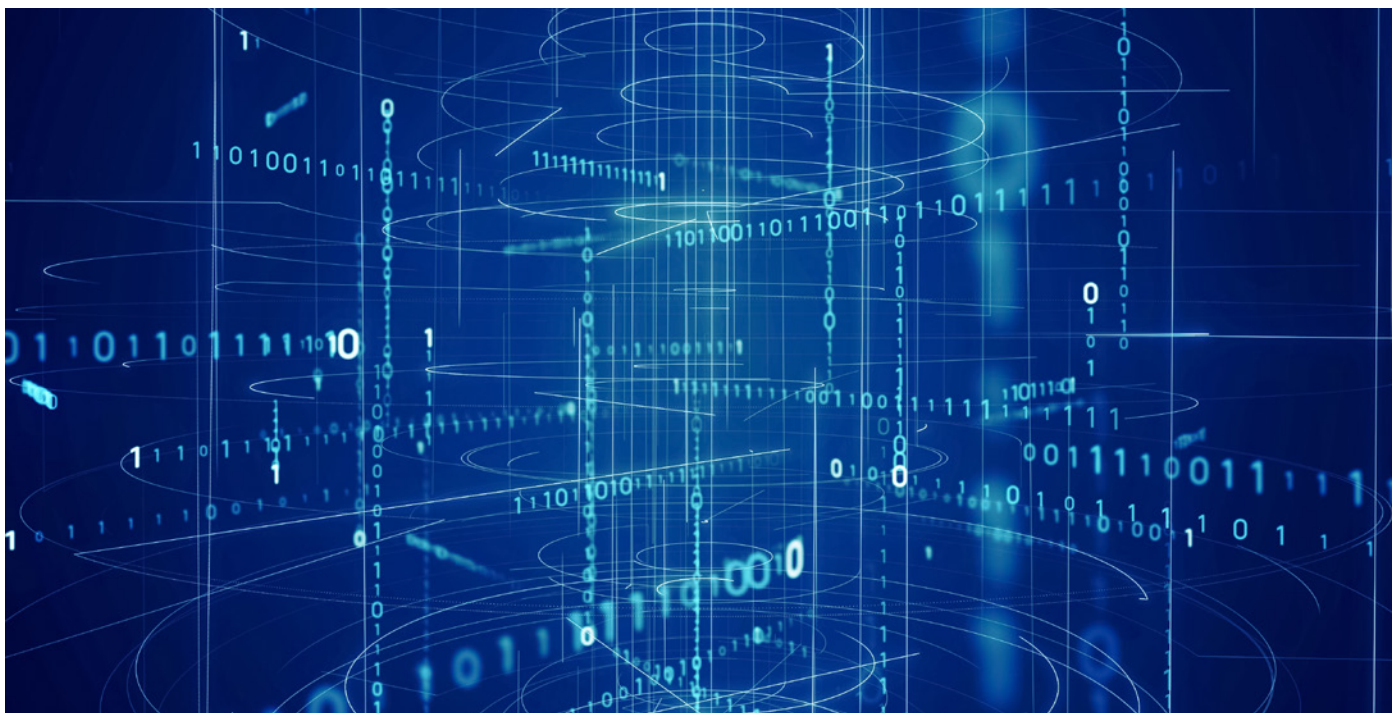

7.9. Future Emerging Technologies

The section on Future Emerging Technologies (FETs) is a collection of trends and technologies that do not fit well to, or do not impact exclusively, one of the other chapters. It is attempted to reach out for technologies beyond the current scope of available lists, such as the ETSI Technology Radar or the Gartner hype cycle. As far as meaningful FETs are presented in a storytelling fashion of user scenarios description, technology description and a view on their potential impact on the UN Sustainable Development Goals (SDGs). Each identified technology has a low Technology Readiness Level (TRL) of typically 2, which means that the technology concept has been formulated, is exiting basic research and entering the phase to prove its feasibility. *Most technologies indicated below, if reaching widespread usage, will impose changes in the overall system design, affecting most (if not all) of the previously mentioned technology trends.*

Quantum computing harnesses the collective properties of quantum states of atoms and subatomic particles, such as superposition, interference, and entanglement, to perform calculations quantum processors, which are able to perform quantum logic gates on a certain number of quantum bits (qubits). **Quantum communication** seeks to utilise quantum mechanics principles for transmission of information. Finally, **quantum networks** facilitate the transmission of information in the form of qubits, between physically separated quantum processors. Quantum networks work in a similar way to classical networks, but are better at solving certain problems. The most prominent and most advanced application of quantum properties in communications is **Quantum Key Distribution (QKD)**, which allows two communication parties to

produce a shared secret key that can be used to encrypt and decrypt communication among them. More applications have been described, like **Quantum Machine Learning** and others.

In the area of security, it is still uncertain when **scalable homomorphic encryption** will reach a maturity level that will allow wider deployment and use. Full homomorphic encryption allows computations to be carried out directly on ciphertext. The result of the computation is left in encrypted form which, when decrypted, results in an identical output to that produced had the operations been performed on the unencrypted data. This allows data to be encrypted and out-sourced to cloud environments for processing, all while encrypted. While various, usually trivial examples, have been demonstrated since decades, scalable solutions suffer from serious degradation of computing performance. Demonstrated solutions based on Trusted Execution Environments (TEEs) are vulnerable to side channel attacks.

Human centric multimodal communication endeavours to exploit (i) advances in technology such as extended reality, holography, extreme miniaturization together with (ii) increased understanding of human cognition and interfacing to all human senses. Applications of extended reality, holographic telepresence, etc. are becoming the norm in social human interaction, gaming and entertainment, as well as remote interventions in medical, manufacturing and maintenance environments. Beyond voice and simple gesture control of services the potentials allow for complex pairing or **entanglement of human interaction devices** that allow context-based transfer of communication sessions between

them, steered by human gesture or **human brain control**. Holography is currently a visual technology, but may evolve to include other senses as well. In particular **holograms** that you can **touch and smell (or robotic avatars)**, will allow remote interactions including the complex interplay of many human senses. Human augmented cognition generally focuses on the intersection of neurosciences and engineering and tries to exploit available human-machine interfaces to capture the human's cognitive state to interact in real-time with ICT systems. Through non-invasive means (EEG or ECG biosensors, Google glasses) or through implants (retina implants) the precision of capturing the cognitive state substantially increases, as increases the detail and resolution of information that could be injected into the human brain resulting in **augmented human cognition**. Despite the ethics question behind this kind of technologies, the advances in medicine and neuroscience at the border of ICT have been challenged by the questions "Restitutio ad Integrum" versus "Transformatio ad Optimum" ever since the first heart pace maker with trans-telephonic monitoring was successfully implanted in 1970. Alternative means of interaction with technologies have prompted the vision of the **disappearance of the smartphone**, which describes a state of technology advancement that allows the complete human social interaction and remote intervention by humans to be executed without the need of a smartphone, solely relying on ambient voice recognition in private and public space, in-ear headsets, and gesture control.

Digital Twin technology is a multi-disciplinary integration technology, which has emerged into the attention of industry and academia. Generally, it describes the real time integration and communication of data between a physical and a virtual artefact in both directions. It allows for rapid analysis and real-time decisions made through accurate analytics. Several enabling technologies are used to support digital twinning, such as IoT, AI and underlying infrastructures, such as 5G and 6G. However, the future network infrastructure may itself be subject to a virtual representation, whereby the borders of virtual versus physical world are fluid due to the high level of virtualisation emerging since 5G. The introduction of digital twinning has the potential to accelerate 6G innovation and experimentation in particular because the issues of scaling and evolution become essentially a matter of extension of the replicas.

Sensing of the environment is increasingly penetrating all areas of the environment where humans live and work. Sensing inside the human body is also not a new technology. Increased understanding of bio-chemical and nano-molecular phenomena prompts the description of use cases that aim to exploit this understanding. **Bio-degradable and digestible sensors** are reaching feasibility levels and are needed for ap-

plications at inaccessible places (oceans, woods, sewage), where the recovery of phased out sensors is impractical. Digestible sensors can be of benefit in care, for example when they are able to notify intake of pills. Other **chemical and biological sensors** are available in medicine the agri-food industry, typically called bio-markers, that can be used to provide indications of environmental conditions or the presence (and absence) of other necessary (or harmful) substances. The extraction of sensed information is not yet embedded in a fully automated value chain, which is intrinsic to the process, mainly because the interfacing questions to ICT are largely unsolved. Similarly in the **nano, bio-/molecular technologies and communications** world, the way of interaction is largely unsolved. Experiments have shown that nano-structures can be constructed that can be steered via electromagnetic fields. This could allow the realisation of applications in medicine for abnormality detection inside blood vessels with mobile nano-machines. Even further the scenario of "swallow your surgent" has been described in which nano machines work inside the body to locate and destroy cancer cells or repair damaged tissue.

3D printing has made substantial progress and is finding its way into printing very small structures pertinent to semiconductors as well as printing bio-materials. This allows 3D printing of bio-degradable and digestible sensors, potentially greatly simplifying the manufacturing process for these materials and structures, as well as simply printing RFID-like tags on packaging. In the large scale the evolution of 3D printing can be described such that deployment of structures like reconfigurable intelligent surfaces can be 3D printed or **3D "sprayed"** on building walls with the objective to greatly ease deployment.

The topic of sustainable ICT will be expanded to serve the full value chain, such that the **energy, greenhouse gas and resource total cost of ownership (TCO)** is calculated for all ICT equipment and services at a fine granular level and considers the extraction and use of raw material, use of purified water and cost for the retirement of equipment including waste management in the circular economy. This is a challenge that needs to be tackled at the system level for innovative communication systems to include sustainability aspects upfront. **Energy harvesting** from the environment or energy induced on demand from outside to wake up user equipment (UE) for a specific task, has been demonstrated and could lead the way to **(near)-zero energy UEs**. Important application areas are deployment of UEs in inaccessible areas and which shall be able to communicate for decades. With respect to user convenience the energy supply in notebooks and smartphones is the "last frontier" of mobile computing and communication.

8. Timeplan and deltas

Technology evolution will not happen suddenly. As the technical annex clearly represents, most of the features we expect to see in the future will be implemented gradually in the infrastructures, as innovation developments reach economical deployment. Given the complexity of the systems we envisaged, an harmonious development in several aspect is required, since improvements in a specific technology domain will enable, and will require, improvements in other technology domains. In order to provide some idea on the expectations of evolution, this section considers three technological nodes, (considering the years of 2025, 2028 and 2031) to identify what type of features are expected to be available in different domains at those times.

These metrics can be used to evaluate technology development from the SRIA point of view. Given the large scope of technologies here discussed, these metrics are multiple and reflect very different essences. There are performance indicators that are typical (and very detailed), but the increasing complexity of the SNS systems require increasingly complex metrics, across a multitude of technology domains. In fact, some of the performance indicators (the metrics themselves) will evolve during the next years.

8.1. System, architecture and software

The following metrics are related with the overall system dynamism. Future systems will be fully accountable and highly dynamic.

2025	2028	2031
Accountability of resource usage for all resources		
At least one resource (including energy) explicitly accounted for, at least 95% accuracy	At least one resource can be explicitly accounted for, across service chains, at accuracy at least 95%	All resources (including energy, carbon/greenhouse gases. Time) can be explicitly accounted for, across service chains in multiple domains, with fair distribution of resources of background loads, at accuracy at least 95%
Availability of descriptions on user populations as it evolves over time, at least 95% accuracy		
User population for at least one service	User population at least three different types of services	User population for most services

2025	2028	2031
Number of inspection/introspection interfaces / parameters that can be introspected in communication systems (NOT just individual devices)		
At least three parameters can be queried	Most parameters can be queried	All relevant parameters can be queried
Number of different deployment unit formats supported by a network		
At least support VMs, containers, and WebAssemblies	Support all network entities	Support all network entities
Ease and scope for network creation emerging out of networks, in useful time		
At least two networks can be merged and split	At least five networks can be merged and split	Arbitrary number of networks can be merged and split

Although there is an important set of issues with defining metrics for all areas, it is particularly challenging for an area as software, where there is a clear lack of understanding on adequate metrics (and its value) in the

community. Nevertheless, our concern is much more on the overall impact of software usage, than on the software metrics aspects.

2025	2028	2031
Reduction of Energy Consumption by using increased usage of software technologies in communication systems (compared with the reference of 1990)		
>23%	>28%	>33%
Speed up of the lifecycle management (LCM) of network service including service design, provisioning, deployment, and operation (compared with the reference of 2020)		
2x	5x	10x
Improvements on different characteristics of software delivery performance using a DevOps approach in a computing continuum environment		
Fulfill one parameter	Fulfill two parameters	Fulfill four parameters

These characteristics should consider:

- a. deployment frequency (how often releases and updates to production are done). Target: ability to support 4 deployments per day.
- b. lead time for changes (the time it takes to get a commit into production). Target: less than one hour
- c. change failure rate (percentage of deployments causing a failure in production). Target: maximum 15%
- d. time to restore (time it takes to recover from a failure in production). Target: less than one hour.

8.2. Security

The following metrics are related with security aspects, increasingly important for 6G networks.

2025	2028	2031
Mission-based security distribution in 6G, beyond obsolete perimetric approaches, with a reference architecture and framework for security development,		
Key proposed 6G architectures	Most 6G architectures with cooperative operations	Exhaustive applicability with Mission-Oriented applications
Level of resource segregation and security profiling in 6G architectures		
Plan-based segregation (user/control/management/service)	Flexible profiling of 6G resource as per security level or associated control	Flexible profiling of 6G resource as per security level and associated control
Secure AI for 6G, structured in a toolbox		
Recommendations for most of 6G-AI protection)	Coverage of constrained use cases	Regulation as per evolution of AI Act
Service-based architecture integrating security either as a service or as a digital service		
Available Security Service Level Attributes template for most of service delivery workflows	Digital Service life cycle integrating provisioning of Security as a Service for most common usages	International mutual recognition of Security Service Level Attributes
Integration of blackboxes and new attack surfaces in 6G conditioned by relevant mitigation strategies keeping security level		
IoT risks mitigation by means of filtering/monitoring	Most of termination points vulnerabilities mitigations	End-to-End continuum assurance through advanced strategies for most of 6G architectures
Providing matching between specific verticals and 6G security capabilities (potentially any functional and non-functional requirement expected from 6G)		
>80% of 6G applications forecast covered	>90% of 6G applications forecast covered	~100% of 6G applications forecast covered
Design and Run of HW-based security in 6G		
System Overarching with security offloading and root of trust	> 70% Applicability on 6G use cases	~100% Applicability on 6G use cases
Safe Code Life Cycle - Framework and process enabling full life cycle mastering		
Uncontrolled code ratio <10% in production	Uncontrolled code ratio <30% in production	Zero unsafe code in critical applications

8.3. Radio and NTN

The metrics related with the air interface are of a different nature. It is expected that 6G will be also defined by a different radio layer, which will be a radical step upwards over 5G. As such, more interim performance metrics are hard to

establish, since these will only be intermediate steps in research, and will never reach any type of implementation. As with other generations, 6G is expected to be a hard discontinuity in the communications radio link technology.

	5G	6G
Bandwidth	<0.5 GHz	10 GHz
Energy efficiency (NW, UE)	Qualitative	>100% gain vs IMT-2020
Experienced spectral efficiency	0.3 b/s/Hz	3 b/s/Hz
Peak data rate	20 Gb/s	1 Tb/s
User data rate	0.1 Gb/s	10 Gb/s
Area traffic capacity	10 Mb/s/m2	1 Gb/s/m2
Reliability	URLLC: >1-10-5	>1-10-8
Mobility	<500 Km/h	<1000 Km/h
U-plane latency	URLLC: <1 ms	<0.1 ms
C-plane latency	<20 ms	<2 ms
Connection density	>1 device/m2	10 device/m2
Positioning accuracy	<1 m	<1 cm

The following metrics are related with NTN. A wide range of new metrics, associated with new services will be important to consider.

	2025	2028	2031
Autonomous positioning capability	Available feature with low positioning accuracy	Available feature with good positioning accuracy	Available feature with high positioning accuracy
Service flexibility	Not achieved	Achieved with acceptable level	Achieved with good level
Support of IoT services to remote locations	Supported with relatively expensive terminals and acceptable efficiency	Supported with low-cost terminals and good efficiency	Supported with low-cost terminals, good efficiency
Communication latency	Acceptable for a restricted set of services	Acceptable for all supported services	Satisfactory for all supported services
Positioning error for the autonomous positioning service	50 meters	10 meters	2 meters

2025	2028	2031
QoS levels to maritime and aeronautical users		
Unacceptable	Acceptable	Satisfactory
Ultra-flexible offered capacity. This key value refers to the satellite fined granularity to offer the intended capacity where needed over the coverage area.		
Some of the satellite capacity remains with no clientes	Most of the terminals have access to satellite capacity	Satellites are able to reconfigure its capacity to reach all terminals needs
Unified chipset and telecom infrastructure		
Software defined radio solutions are available for low data rates	Unified hardware-RF solutions available for NTN and TN	Same equipment for NTN and TN is provided by vendors
Seamless interoperability		
Satellite access is ensured by the user with a dedicated interface	Users experience a faulty network when migrating from TN to NTN	User are not aware whether they are connected to a NTN or TN
Smartphone connectivity for voice and video		
Smartphones can only send text uplink messages	Interactive voice communication is available	Full data uplink and downlink communication takes place
User-level service level accomplishment		
99 %	99.9%	99.99%
Spectral efficiency		
uplink 0.5 - 1 bps/Hz downlink 1-3 bps/Hz	uplink 0.5 – 1.5 bps/Hz downlink 1.5 - 4 bps/Hz	uplink 1 – 3 bps/Hz downlink 1.5 - 4 bps/Hz
Terrestrial and non-terrestrial handover delay		
Few seconds to minutes	Less than a second	Perception of zero delay
Radio terminal power consumption		
26 dBm	21 dBm	18 dBm
Network Architecture		
Programmable Data Plane	Dynamic NG-RAN functional splitting	Orchestration of network slicing driven by AI

2025	2028	2031
Network Management/Orchestration		
Orchestration for converged NTN-TN Infrastructures	Unified orchestration in 3D Networks	Intent-based network orchestration
Routing in Space		
Traffic engineering and flexible IP forwarding	Semantic routing taking into consideration differentiated contexts	Service-centric routing able to support full convergence of networking and computing
Latency		
Moderate reduction for non-real time services through proper NTN layer selection	Optimized latency-driven service deployment for reduced latency services	Seamless integration with TN aiming at automatically deploying services depend on the latency requirements
Autonomous service deployment		
Reactive automatic service deployment based on user request	Proactive automatic service deployment based on user request	AI-driven multi-service deployment
Global coverage		
Ground user global coverage with Edge Computing solutions through NTN connections	In-orbit services coverage with Edge Computing Solutions through NTN connections	Joint ground and in-orbit service global coverage through integrated in-orbit and ground Edge Computing solutions
Distributed Processing		
NTN layers will be used as backup/offloading facilities when ground nodes cannot satisfy user requests	NTN layers will be integrated with TN for providing distributed processing platforms for use requests	Transparent joint NTN/TN distributed platform solution for both ground and in-orbit service request
Space In- network computing		
NTN nodes are used for remotely processing tasks	NTN and Space nodes are jointly used for remotely processing tasks	NTN and Space nodes have distributed in-network processing functions
Distributed Learning		
NTN platforms can be used as centralized nodes for data collection during distributed learning	NTN nodes can participate to distributed learning algorithms executions	NTN nodes are integrated with TN for creating a unique distributed learning environment

2025	2028	2031
Supporting critical data transmissions		
In 2025 there will not be any NTN that supports critical service	In 2028 at least emergency services from NTN to phone will be supported	In 2031 full critical services from NTN will be supported
Traffic load in secure networks		
In 2025 will not be traffic load with new paradigms of security	In 2028 50% of the traffic from NTN will support new paradigms of security	In 2031 90% of the traffic from NTN will support new paradigms of security
Revenue of companies that provide secure TN/NT		
In 2025 no revenue from new security paradigms introduced in NTN will be provided	In 2028 more than 50% of the revenues in NTN will be provided from new secure paradigms	In 2028 more than 80% of the revenues in NTN will be provided from new secure paradigms
Secrecy rate of the NTN communications		
20% increase of secrecy rate compared to not introducing them for 2025	30% increase of secrecy rate compared to not introducing them for 2028. (10% of increase respect 2025)	40% increase of secrecy rate compared to not introducing them for 2031. (10% of increase respect 2028)
Latency of NT network after introducing security constraints		
20% increase compared to not introducing new security measures for 2025	10% increase compared to not introducing new security measures for 2028 (50% of reduction)	5% increase compared to not introducing new security measures for 2031 (50% of reduction)
Recovery time after suffering an attack in an NT network		
1h of recovery time for 2025	30' of recovery time (50% of improvement) for 2028	15' of recovery time (50% of improvement) for 2031
False alarm/Detection probability of being attacked		
90% of Detection Probability of being attacked for 2025	99% of Detection Probability of being attacked (10% of improvement) for 2028	99.9% Detection Probability of being attacked (10% of improvement) for 2031

8.4. Optical

For the optical aspects, the following metrics can be considered

	Target KPI	Current 2022	Mid-term Evo ~2028	Long-term Evo ~2031	Long-term Evo ~2031
Metro/Core	Spectrum ¹	5THz	10THz	20THz	50THz
	Port speed ²	400Gb/s	1.6Tb/s	3.2Tb/s	6.4Tb/s
	Bandwidth ³	<75GHz	<300GHz	<600GHz	<1200GHz
	Line capacity ⁴	25Tb/s	100Tb/s	300Tb/s	1Pb/s
	Node capacity ⁵	150Tb/s	600Tb/s	1.8Pb/s	6Pb/s
Access	PON speeds	25Gb/s	50Gb/s	100Gb/s	>200Gb/s
	User data rate ⁶ (consumer)	~500Mb/s	~1Gb/s	>2.5Gb/s	>5Gb/s
	User data rate ⁶ (business)	~5Gb/s	~10Gb/s	>25Gb/s	>50Gb/s
	Latency ⁷	<1ms	<100µs	<10µs	<1µs
	Power consumption ⁸	100% (baseline)	40%	30%	20%
	Service provisioning	Hour	Min	Second	Sub-second
	Network operations	Operator-controlled, reactive	Intent-based, proactive	Self-diagnosing	Self-optimizing

¹ 25% CAGR, in line with conservative traffic predictions. Assumes spectrum for SMF

² Extrapolation of Ethernet roadmap

³ Using 400G DP-16QAM as baseline

⁴ 50% CAGR, in line with internet content provider traffic predictions. Assumes exploitation of frequency and space domain.

⁵ Based on degree 4 node with 50% local add/drop

⁶ 6: 6: typical user data rate, averaged over different deployment scenarios and system configurations

⁷ Excluding propagation delay

⁸ 15% reduction per Gb/s p.a., extrapolated from past transponder data



8.5. Devices and Components

For the device and component technologies, the following metrics should be used as minimum target.

2025	2028	2031
sub-10GHz radios energy efficiency		
x 2.5	x 5	x 10
sub-10GHz radios EVM		
-6 dB	-9 dB	-12 dB
mm-wave and THz radios energy efficiency		
x 4	x 8	x 16
Mm-wave and THz EVM		
-6 dB	-9 dB	-12 dB
ADCs sub-10GHz UE		
F_samp: same ENOB: +1 FoM: same (resolution improvement at constant FoM)	F_samp: x 2 ENOB: same FoM: same (larger BW at constant FoM)	F_samp: same ENOB: same FoM: divided by 2 (same perf but better FoM)
ADCs sub-10GHz BS		
F_samp: x 1.5 ENOB: same FoM: same (larger BW at constant FoM)	F_samp: x 1.5 ENOB: same FoM: same (larger BW at constant FoM)	F_samp: same ENOB: same FoM: divided by 2 (same perf but better FoM)
ADCs mm-wave and sub-THz		
F_samp: x 1.5 ENOB: +1 FoM: same (performance improvement at constant FoM)	F_samp: x 1.5 ENOB: same FoM: same (larger BW at constant FoM)	F_samp: same ENOB: same FoM: divided by 2 (same perf but better FoM)
Mm-wave and THz EVM		
-6 dB	-9 dB	-12 dB
Mm-wave and THz EVM		
-6 dB	-9 dB	-12 dB

2025	2028	2031
Ultra-low power wireless power consumption		
/ 4	/ 8	/ 16
Package loss and antenna efficiency at mm-wave and higher		
+6 dB	+9 dB	+12dB
Digital modem and DSP efficiency		
x 4	x 8	x 16



9. Conclusion

In this paper we provided the summary of European 6G research and innovation targets for upcoming years. The document provided the insight of technology research and development for society and economy in Europe, and in global perspective. In addition, we showed the alignment of EU policies and programs such as Green Deal, Chip Act, IPCEI and Trustworthy AI, as well as the several European Members State initiatives for 6G and 5G evolution R&D&I. Innovating in communication systems is critical to realize the sustainable development challenges we face, and we need to balance innovation in system flexibility, security and openness with aspects associated with sustainability (green systems, energy-efficiency) in a realistic context associated with current and future requirements.

When taking the look of emerging needs for 6G system development, we can say that the vision of 6G is formed around three main pillars, namely 1) **sustainability and energy-efficiency**, and 2) **security and trustworthiness**; 3) **performance boost**.

For sustainability, the United Nation's Sustainability Goals are driving European society development, and as a consequence, our future communication infrastructures. Sustainability must also consider economical sustainability for the telecommunication industry, meaning the sustainable business opportunities also in the long run, as well as ecological and societal sustainability. The system should be sustainable not only from energy consumption point of view but also from lifecycle of system core components, and operations point of view, an area often neglected, and that strongly depends on law and regulations. Telecommunication system sustainability needs to be verified also from economical sustainability and social sustainability point of view. The finding of balance for these

viewpoints affects also to future technology development per se.

With the increased intertwining between technology and society, the system needs to be secure and trustworthy. This means we require a communication infrastructure that is dependable, stable, secure and resilient, and provide a platform which is natively trustworthy from users and the system operators/service providers point of view and enable tailored security as a service for different operations and use cases. As the system needs to be easily manageable, there is requirement of a high trust level on the automation methods in different network and system management, which is another often neglected dimension: This could imply that, e.g., AI based decision must be explainable, or some other form of bringing human-in-the-loop should be implemented. The efficient end-to-end management of resources leads to complex system optimization problems where system global optimum cannot be found using local optimization. Moreover, sometimes the system optimization aspects are constrained by conflicting human policy aspects, that need to be properly fulfilled to satisfy economical, political, societal and regulatory requirements.

Finally, the future mobile telecommunication system's performance needs to be quantitatively better than the current one. This implies that the target key performance indicators, such as, peak data rates, latency, jitter, spectral efficiency, device density, etc., should be far better than the current 4G and 5G basic systems can provide. But furthermore, different sets of performance indicators are appearing both as a consequence of the trends above (sustainability and trustworthiness are good examples for the appearance of qualitatively different indicators) and as a consequence of the increased blending between commu-



nications and processing technologies. This implies that a new set of indicators needs to be discussed and consensual inside the community, implicitly defining the important aspects that will differentiate the future 6G networks. While traditional metrics (e.g. cell average throughput, cell peak data rate) are well defined and easy to assess in simulations and field test, for novel performance indicators the situation is not so clear yet. When considering “green systems”, end to end comparisons are still difficult to achieve, but clear and transparent methodologies will be needed to globally simultaneously assess aspects such as service requirements, energy consumption, and carbon intensity.

Many of these aspects have been touched in this SRIA, and much further technical details can be found in the accom-

panying technical annexes. The Networld Europe SRIA, including its technical annexes, presents long-term research for Europe, reflecting European policies (such as the Green Deal, the Chip Act, and the AI Act trends), and considering a diversity of key technologies important for Europe to remain in the leadership of next generation green communication infrastructures. As technology interpenetration increases, mastering these interrelations will become increasingly important to the success of research in Europe.

10. References

[EC-EGD 2019] European Commission: The European Green Deal. Communication from the Commission to the European Parliament, the European Council, the Council, the European Economic and Social Committee and the Committee of the Regions, Brussels, 11.12.2019 COM(2019) 640 final, https://ec.europa.eu/info/sites/info/files/european-green-deal-communication_en.pdf.

[SRIA 2020] Networld2020, Strategic Research and Innovation Agenda 2021-27, Smart Networks in the context of NGI, Sep 2020. <https://bscw.5g-ppp.eu/pub/bscw.cgi/d367342/Networld2020%20SRIA%202020%20Final%20Version%202.2%20.pdf>

Cite as:

Aguiar, R.L.; Bourse, D.; Hecker, A.; Huusko, J.; Pouttu, A.; Strategic Research and Innovation Agenda 2022, NetworldEurope, Dec 2022 DOI: 10.5281/zenodo.7454872



NETWORLD
EUROPE

networldeurope.eu