



D2_2a: Principles behind the FCDR effects table

Emma Woolliams, Jonathan Mittaz, Chris Merchant and Peter Harris

National Physical Laboratory and Reading University

25th August 2017



FIDUCEO has received funding from the European Union's Horizon 2020 Programme for Research and Innovation, under Grant Agreement no. 638822

1	Introduction	4
1.1	Scope.....	4
1.2	Version Control	4
1.3	Applicable and Reference Documents.....	4
1.3.1	D2-2 set of documents.....	4
1.3.2	References	4
1.4	Glossary.....	5
2	General overview	6
2.1	An uncertainty-quantified FCDR	6
2.2	Errors and uncertainties.....	7
2.3	Uncertainty analysis.....	7
2.4	Correlation: random and systematic effects	9
3	The full FCDR and the effects tables	10
3.1	What we need to know to propagate uncertainties.....	10
3.2	Establishing the FCDR starting from a measurement function.....	10
3.2.1	The measurement function	10
3.2.2	Effects.....	10
3.2.3	Three different types of error correlation to consider	10
3.2.4	The Plus Zero term	11
3.2.5	Harmonisation and the harmonisation coefficients	11
3.3	Drawing the measurement-function-centred diagram	12
3.3.1	Diagram.....	12
3.3.2	How deep should we go?.....	12
3.3.3	Similar effects, common errors and correlations between quantities in the measurement function	13
3.4	Simplifications in the presentation of the FCDR.....	14
3.4.1	Linear assumptions	14
3.4.2	Uncertainty distributions	15
3.4.3	Correlation forms.....	15
4	Error correlation form definition	15
4.1	Error correlation dimensions	15
4.2	Possible error correlation forms	17
5	The Effects table	20

5.1	Effects table overview.....	20
5.2	Correlation forms.....	21
5.3	Uncertainty	21
5.4	Sensitivity coefficients	23
5.5	Correlation between channels.....	23
5.6	Coding the effects table.....	23
6	Harmonisation and harmonisation coefficients	23
6.1	Information required for harmonisation	23
6.2	Covariance associated with the harmonisation coefficients	24
6.3	Coding information on the harmonisation coefficients.....	24
7	Using the FCDR effects table.....	25
7.1	The uncertainty associated with a single observation in a single channel at a single pixel	25
7.2	The covariance associated with observations in different channels at a single pixel	25
7.3	The uncertainty associated with observations in a single channel at different pixels	26
8	Conclusions	27
A	Appendix on errors, uncertainties and correlation	28
A.1	Errors and uncertainties.....	28
A.2	Error correlation and quantity correlation	28
A.2.1	Random errors	28
A.2.2	Structured random errors.....	29
A.2.3	Systematic errors	29
A.2.4	Error correlation and geophysical correlation	29
A.3	Type A and Type B methods for evaluating uncertainty and correlation	29
B	Appendix on error correlation and error covariance.....	30
B.1	Error correlation and covariance concepts.....	30
B.2	Information required in the FCDR.....	31
B.3	Derivation of correlation forms for spectral channels.....	31
B.3.1	Type A method to evaluate correlation	31
B.3.2	Channel-to-channel correlations	32
B.4	Pixel-to-pixel correlation forms	32
B.4.1	Type A methods	32
B.4.2	Rectangular absolute	32
B.4.3	Deriving the triangular correlation form for a simple rolling average.....	32
B.4.4	Deriving the bell-shaped correlation form for a weighted rolling average	34

B.4.5	Repeating correlation forms	38
B.4.6	The stepped triangle correlation form.....	38

1 Introduction

1.1 Scope

This document describes the FCDR effects tables being developed in the FIDUCEO project. It has the following aims:

- To describe what the effects table is, how it is to be filled in by FCDR developers and how it is anticipated to be used
- To record (in appendices) the derivation of equations for the different correlation forms

It forms the basis of the overall deliverable D2-2, and has been developed in parallel with the sensor specific partner documents describing the effects tables for each of the 4 FCDRs in the FIDUCEO project.

1.2 Version Control

Version	Reason	Reviewer	Date of Issue
1.a	Initial release	UREAD, NPL	29/8/17
1.b			
1.c			

1.3 Applicable and Reference Documents

1.3.1 D2-2 set of documents

D2-2a	Principles behind the FCDR effects table (This document)
D2-2(microwave)	Report on the MW FCDR: Uncertainty
D2-2(HIRS)	Report on the HIRS FCDR: Uncertainty
D2-2(AVHRR)	Report on the AVHRR FCDR: Uncertainty
D2-2(MVIRI)	Report on the MVIRI FCDR: Uncertainty

1.3.2 References

Allan, D, 1966, Statistics of Atomic Frequency Standards, Proceedings of IEEE, 54, 211-230

Block, T and S Embacher, 2017, CDR/FCDR File Format Specification. FIDUCEO deliverable D3.1

FIDUCEO Vocabulary: <http://www.fiduceo.eu/vocabulary>

GUM (2008): JCGM 100:2008 Evaluation of measurement data – Guide to the expression of uncertainty in measurement, Report, <http://www.bipm.org/en/publications/guides>

Hunt et al (2017): FIDUCEO report in preparation to describe the process of harmonisation

J Mittaz (2016): FIDUCEO report: “Instrument Noise characterization and the Allan/M-sample variance”.
<http://www.fiduceo.eu>

VIM (2008): JCGM 200:2008 International vocabulary of metrology - basic and general concepts and associated terms, <http://www.bipm.org/en/publications/guides>.

1.4 Glossary

AVHRR	Advanced Very High Resolution Radiometer
GUM	Guide to the expression on uncertainty in measurement
HIRS	High resolution Infra-red Radiation Sounder
FCDR	Fundamental Climate Data Record
MVIRI	Meteosat Visible and Infrared Imager
PRT	Platinum resistance thermometer
TOA	Top of atmosphere
VIM	International Vocabulary of Metrology (abbreviation from French title)

2 General overview

2.1 An uncertainty-quantified FCDR

Our FIDUCEO vocabulary defines an *uncertainty-quantified fundamental climate data record* (FCDR) as:

A record of calibrated, geolocated, directly-measured satellite observations in geophysical units (such as radiance) in which estimates of total uncertainty (or error covariance) and/or dominant components of uncertainty (or error covariance) are provided or characterised at pixel-level (and potentially larger) scales. The FCDR should be provided with all relevant auxiliary information for the data to be meaningful, including, e.g. time of acquisition, longitude and latitude, solar and viewing angles, sensor spectral response.

The FCDR is a long-term record of a geophysical quantity measured by a satellite with all the necessary information to interpret that record in a quantitative manner. FCDRs are produced as an initial step in a processing chain. They are used when they are converted into climate data records (CDRs) of higher level products, a process that can combine FCDR data values from different spectral channels and combine FCDR data values from different observational pixels.

To understand the uncertainty associated with the CDR generated from the FCDR we need to understand not only the uncertainty associated with the FCDR at the pixel level, but also the error covariance of that FCDR from pixel-to-pixel and from spectral channel to spectral channel.

In FIDUCEO we have defined a systematic method for presenting this error covariance information so that it can be used for CDR generation. The systematic approach also acts as a way of documenting the origin of uncertainties in the FCDR. The FCDR uncertainty analysis can be broken down into the following steps:

- We determine the measurement function for the FCDR which expresses the relationship between the measurand (usually pixel-level Earth radiance, reflectance or brightness temperature) and the input raw quantities used to calculate this (measured counts, calibration system radiances, gains and nonlinearity terms, correction factors).
- For each term in the measurement function we record its origin and the different uncertainty effects that influence the value obtained.
- For each uncertainty effect we evaluate an associated uncertainty and consider the correlation of an error in that effect between observational pixels, across time and across spectral bands. We use all available information to provide the most robust estimate of this uncertainty and correlation and document that evidence.
- For each uncertainty effect we fill in the FIDUCEO effects table (see Section 5) which provides a common approach to documenting the necessary information and which can be coded into the NetCDF-compliant full-FCDR.

In this document we discuss the practical implementation of each of these effects. The appendices provide some of the information behind this. We also, in Section 7, begin a discussion into how the effects tables are used in CDR generation. That is work that will continue in later stages of this project and will be later presented in D2-4.

2.2 Errors and uncertainties

A fuller introduction to errors and uncertainties is given in Appendix A. Here we review some key concepts to support the reader in understanding the rest of this document.

The International Vocabulary of Metrology (VIM 2008) defines measurement uncertainty as:

a non-negative parameter characterizing the dispersion of the quantity values being attributed to a measurand, based on the information used.

The standard uncertainty is the measurement uncertainty expressed as a standard deviation.

Measurement error is defined in the VIM as:

the measured quantity value minus a reference quantity value.

The VIM notes that this term can be used both where there is a known reference value (and thus the measurement error is known) and where the measurand is represented by a unique true quantity value, in which case the measurement error is unknown. In this paper we use the term 'error' only in the second sense: the measured value differs from the true value by an unknown error.

In Earth Observation (EO), there are similar distinctions. Sometimes it is possible to estimate the difference between the measured value and the true value, and apply an appropriate 'correction'. For example, when producing L1 products from microwave radiometers it is common to apply an 'antenna pattern correction' to reduce the influence of side-lobe sensitivity on the variation of radiance across a scan. The correction is calculated from measured behaviour (e.g. pre-flight characterisation of the antenna pattern) and assumptions (e.g. about the source spatial variation in the side lobes). It is never perfect because of errors in the measurement and the assumptions. A residual, unknown error remains after correction.

Unknown errors arise in the calibration process (whether pre-flight or on-board); often, those result in a systematic error that, in theory, could be corrected for, but practically the information for such a correction is not available. Noise is an example of an effect that cannot be corrected for, not even in principle.

Although errors are unknown, we can evaluate the uncertainty associated with the measured value. Estimating the uncertainty involves complex considerations, because any measurement is sensitive to several different sources of uncertainty, or 'effects', for example nonlinearity, non-uniformity, detector temperature sensitivity, etc. Each effect gives rise to an unknown error drawn from a probability distribution described by the uncertainty. Uncertainty analysis is the process of combining the uncertainty associated with different effects to determine the uncertainty associated with a measurand (a fuller discussion of the difference between errors and uncertainties is given in Appendix A).

2.3 Uncertainty analysis

The FIDUCEO approach to uncertainty analysis and metrological traceability is to start with the measurement function. The VIM 2008 formally defines a measurement function as:

a function of quantities, the value of which, when calculated using known quantity values for the input quantities in a measurement model, is a measured quantity value of the output quantity in the measurement model.

where,

the measurement model is the mathematical relation among all quantities known to be involved in a measurement.

Here the word “measurement” must be considered in its broadest sense and includes the concept of an indirect measurement, where an indicated quantity (e.g. a signal count) is transformed to the measurand (e.g. radiance), which is the quantity intended to be measured. Furthermore, this concept can be extended. For example, for the MVIRI FCDR we consider top-of-atmosphere reflectance as the measurand and for the microwave and thermal infrared sensors, brightness temperature is the measurand, despite the fact in all these cases the strict measurement is a count value from an input optical flux, and the instrument is calibrated to “measure” radiance.

The measurement function is defined from the measurement model which establishes the mathematical relations between the input quantities. Input quantities are, for example, the counts and the calibration coefficients. Note that this concept is also often known as the “measurement equation”. Here we use the word “function” in the most general sense. For the sensors under consideration we can explicitly write the measurement function in terms of an analytic expression, $Y = f(X_1, X_2, \dots, X_N) + 0$. In other cases, the measurement function is defined by e.g. the iterative solution of a measurement model through code.

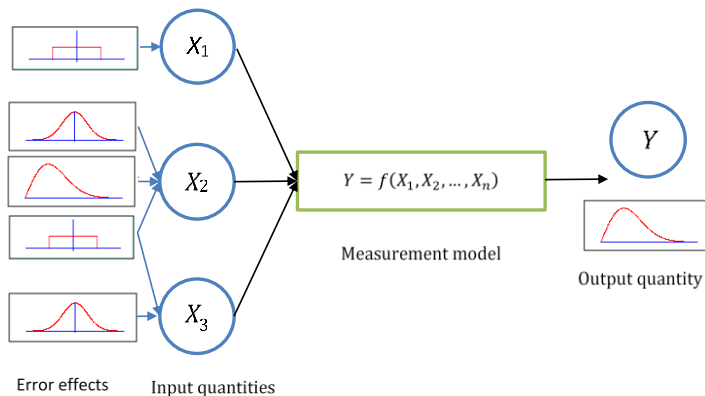

Figure 1 Conceptual process of uncertainty propagation. Here each input quantity, X_i , is sensitive to an error from one or more error effects. One error effect is shown to influence both X_2 and X_3 ; this implies that there is a common error and hence correlation between the input quantities.

In FIDUCEO we perform our uncertainty analysis by considering the different input quantities to the measurement function. Each input quantity may be influenced by one or more error effects, each of which has an associated probability distribution and our aim is to establish the probability distribution of the output quantity. This is shown schematically in Figure 1. In a processing (or metrological traceability) chain there will be a series of such combinations, where the output quantity of one stage becomes an input quantity of the next stage.

Note that we should also consider the extent to which the measurement function describes the true physical state of the instrument. We usually account for this by including a term zero. This explicitly represents effects expected to have zero mean that are not captured by the measurement function (i.e. there is an uncertainty associated with this quantity being zero). Therefore we write the measurement function as:

$$Y = f(X_1, X_2, \dots, X_N) + 0. \quad \text{Eq 2-1}$$

The Guide to the Expression of Uncertainty in Measurement, known as ‘the GUM’ (GUM, 2008), provides guidance on how to determine, combine and express uncertainty. There are two basic methods for

performing uncertainty analysis that are described by the GUM and its supplements: the analytical way using the Law of Propagation of Uncertainty and the numerical way using Monte Carlo Methods. Monte Carlo can provide more information about the shape of the output probability distribution, deals better with highly non-linear measurement models and with more complex probability distributions and can be the only option for models that cannot be written algebraically. However, due to the numerous iterations required, it is computationally expensive. Understanding the sensitivity of the output quantity to each individual input quantity is straightforward (but approximate) when using the Law of Propagation of Uncertainty; with Monte Carlo it requires separate computational runs for each input quantity in turn.

2.4 Correlation: random and systematic effects

The measured value in each pixel of an FCDR comes from a separate measurement. In transforming the FCDR to a Climate Data Record, measurements from different pixels and/or different spectral bands (channels) may be combined for a given result. Thus, the correlation between errors needs to be considered. For that, we distinguish systematic, random and structured random errors.

The term random error is used here to imply independence (strictly, we mean independent random errors), such that the error in one measured value is in no way predictable from knowledge of the error in another, even were that knowledge available.

Random effects are those causing errors that cannot be corrected for in a single measured value, even in principle, because the effect is stochastic. Random effects for a particular measurement process vary unpredictably from (one set of) measurement(s) to (another set of) measurement(s). These produce random errors which are entirely uncorrelated between measurements (or sets of measurements) and generally are reduced by averaging. (FIDUCEO vocabulary)

Systematic errors are errors that have predictable relationships from one measured value to another, and that in principle, but not in practice, could be corrected were additional information known (since the underlying effect is deterministic). Bias is a particular form of systematic error in which the error is in common between measured values, but not all systematic errors are simple biases.

Systematic effects are those for a particular measurement process that do not vary (or vary coherently) from (one set of) measurement(s) to (another set of) measurement(s) and therefore produce systematic errors that cannot be reduced by averaging. (FIDUCEO vocabulary)

Structured random errors arise from random effects where the unknown error affects multiple pixels and/or bands (channels). An example is a scanning sensor for which calibration against a target is performed once per scan. Any random error in the measured target would affect all Earth radiance pixels for which that calibration were used. Such errors are structured because there are predictable relationships between the errors in different measured values, and are random because there is no information, even in principle, that would enable the errors to be corrected (since the underlying effect is random).

Structured random means that across many observations there is a deterministic pattern of errors whose amplitude is stochastically drawn from an underlying probability distribution; “structured random” therefore implies “unpredictable” and “correlated across measurements”; ... (FIDUCEO vocabulary, excerpt)

3 The full FCDR and the effects tables

3.1 What we need to know to propagate uncertainties

In FIDUCEO we have defined an effects table (Section 5) which describes:

- the uncertainty associated with a given effect
- the sensitivity coefficient required to propagate uncertainties associated with that effect to uncertainties associated with the measurand (Earth radiance, reflectance or brightness temperature)
- the correlation structure over spatial, temporal and spectral scales for errors from this effect

This document discusses the structure of the effects tables and how the values in the effects tables are determined conceptually. A detailed discussion about the effects tables for each FCDR is given in the FCDR-specific D2-2 documents.

3.2 Establishing the FCDR starting from a measurement function

3.2.1 The measurement function

All FCDRs are calculated from a measurement function. This is an equation¹ that calculates the FCDR measurand (e.g. radiance, reflectance or brightness temperature) from raw measurement counts and calibration parameters (e.g. gains, offsets and non-linear parameters). Some of these calibration parameters may be set from pre-launch (or design) considerations, others will be established in orbit (e.g. from an on-board or vicarious calibration approach) and finally some will be established retrospectively, through harmonisation processes.

3.2.2 Effects

Our estimate or measurement of any term in the measurement function will be uncertain and thus all values used in the measurement equation will have one or more associated (unknown) errors. In establishing the FCDR we must estimate the uncertainty associated with each effect that gives rise to an error in each term in the measurement function. Almost² all quantities in the measurement equation will have at least one associated effect, some quantities will have several effects.

3.2.3 Three different types of error correlation to consider

Each effect will have an associated uncertainty and that means that it will lead to an (unknown) error. In order to use the FCDR we need to understand the correlation in three different senses:

- The error correlation between different quantities in the measurement function is needed for determining L1 radiance uncertainty. Such error correlations arise from effects in common between quantities, and where quantities are determined from a common fit to data.

¹ For all FIDUCEO FCDRs the measurement function is an equation. In principle a measurement function could be an algorithm described in code rather than as an equation.

² The exceptions are fundamental (e.g. speed of light) and mathematical (e.g. π) constants and a very small number of other terms, used as indicators/agreed references. There may be a few cases where we consider the uncertainty associated with a given quantity to be truly negligible, but such decisions should be justified.

- The error correlation between measured values in different image pixels of a given spectral band is needed to find uncertainty in results based on combining different pixels, e.g. spatial averaging.
- The error correlation between measured values in different spectral bands is needed to determine uncertainty in a multi-channel retrieval for most L2 products. Such error correlation could arise if a common calibration source is used to calibrate different channels.

These are fundamentally different types of correlation and will have to be considered separately. Error correlation between different terms in the measurement function is considered in Section 3.3.3. Error correlation between different pixels is considered in Section 5.2 and error correlation between spectral channels in Section 5.5.

3.2.4 The Plus Zero term

The measurement function includes a term + 0. This zero represents the recognition that all measurement functions are approximations to the physical process they describe. This term considers the extent to which the equality of the measurement function may not hold. For example, if the measurement function is a linear equation, the + 0 term considers the extent to which the instrument may be non-linear. Similarly, if the measurement function is a spectral integral determined numerically using a trapezium or rectangular rule, the + 0 considers the extent to which this rule acts as an approximation of the integrated quantity.

3.2.5 Harmonisation and the harmonisation coefficients

The FCDR measurement function typically contains calibration parameters that have been determined from a calibration process performed during the FCDR development. These calibration parameters generally represent physical attributes of the instrument (e.g. its nonlinearity, the in-flight degradation of mirrors, or a stray light correction) where better calibration information is available for the post-launch situation through comparisons with a reference than is available from applying the pre-flight calibration. Such calibration parameters may be used to account for an observed systematic effect that is inherent to the instrument, for example calibration drift over time, or for empirically demonstrated systematic effects (e.g. instrument temperature sensitivity) even where the exact physical cause cannot be determined.

In the FIDUCEO project, the MVIRI sensor drifts and biases are corrected by calibrating the instrument against a small number of stable ground sites whose top-of-atmosphere (TOA) radiance has been determined using a radiative transfer model. For the other FIDUCEO sensors, the recalibration is obtained using harmonisation: where match-ups³ with other sensors in the series and with a reference sensor are used to determine physical-origin calibration coefficients (the harmonisation coefficients) in the measurement function.

In all these cases a set of harmonisation/calibration parameters is determined by fitting a model to observational data. In FIDUCEO we use a_i in the measurement functions to represent these parameters. The FIDUCEO harmonisation approach requires consideration of the error correlation structure of the

³ A sensor “point” measurement that is matched with another sensor’s “point” measurement sufficiently close in space and time. In a more practical context, a match up consists of two or more sensor pixels (with optional surrounding pixels) that have been acquired at almost the same time and cover almost the same location. Time and spatial difference allowed are defined by the scientific aim. The match up data consists of all data variables at the location and all metadata for each sensor. (FIDUCEO vocabulary)

observational data. Furthermore, the different α_i terms, having been obtained from the same observational data, are usually correlated with one another⁴.

For these reasons the harmonisation coefficients are not considered in the same effects tables as other quantities in the measurement function. They are discussed in Section 6.

3.3 Drawing the measurement-function-centred diagram

3.3.1 Diagram

To describe the metrological traceability of the observations, we have formalised a diagrammatic representation in the form of a “tree” centred on the measurement function. A simplified version of the AVHRR diagram is given in Figure 2. The measurement function is placed in the centre, and for each parameter within the equation we consider the origin of uncertainties associated with that quantity. The sensitivity coefficients, expressed as partial derivatives, relate an uncertainty in one quantity to the uncertainty in the calculated quantity. At the end of each “twig” of this “tree”, there are the effects (Section 3.2.2).

3.3.2 How deep should we go?

It is often possible to “dig deeper” in the measurement function. For example with the thermal infrared and microwave FCDRs, the measurement model includes a term for the radiance of the internal warm calibration target. This is calculated from the temperature of the target. The temperature of the target is determined from the (weighted) average temperature of several onboard PRTs⁵, and their individual temperatures are determined from a signal (counts) and a polynomial that relates resistance to temperature. Thus we could write the counts and resistance polynomial for the different PRTs into the measurement model, but then the measurement model would no longer be intuitively understandable.

We therefore have to balance the need for an intuitively understandable measurement model with the desire for a rigorous and full understanding of the on-board measurement instrument and a complete uncertainty analysis. This compromise requires serious consideration. At some level, in documentation and, of course, in the processing itself, it is necessary to record the origin of each term in the measurement model and the data used in processing. This means that the sub-equations must be written out in the documentation, but not necessarily by creating a single measurement model that includes all terms.

In determining uncertainties we should also consider how instruments were calibrated. In the example given above, of the PRTs measuring the target temperature, although the equation relating PRT counts to temperature is a high-order polynomial, it would not be appropriate to estimate uncertainties in the individual coefficients of that polynomial, as these were determined originally by placing the PRT at a known temperature and observing the counts. There are therefore unknown correlations between the polynomial coefficients. It is more sensible to think about the calibration uncertainty of the PRT in kelvin.

⁴ The degree of correlation is determined during the harmonisation process. If it is extremely high it may not be meaningful to determine the two highly correlated harmonisation parameters separately and in that case the measurement equation may need reconsideration.

⁵ Platinum Resistance Thermometers

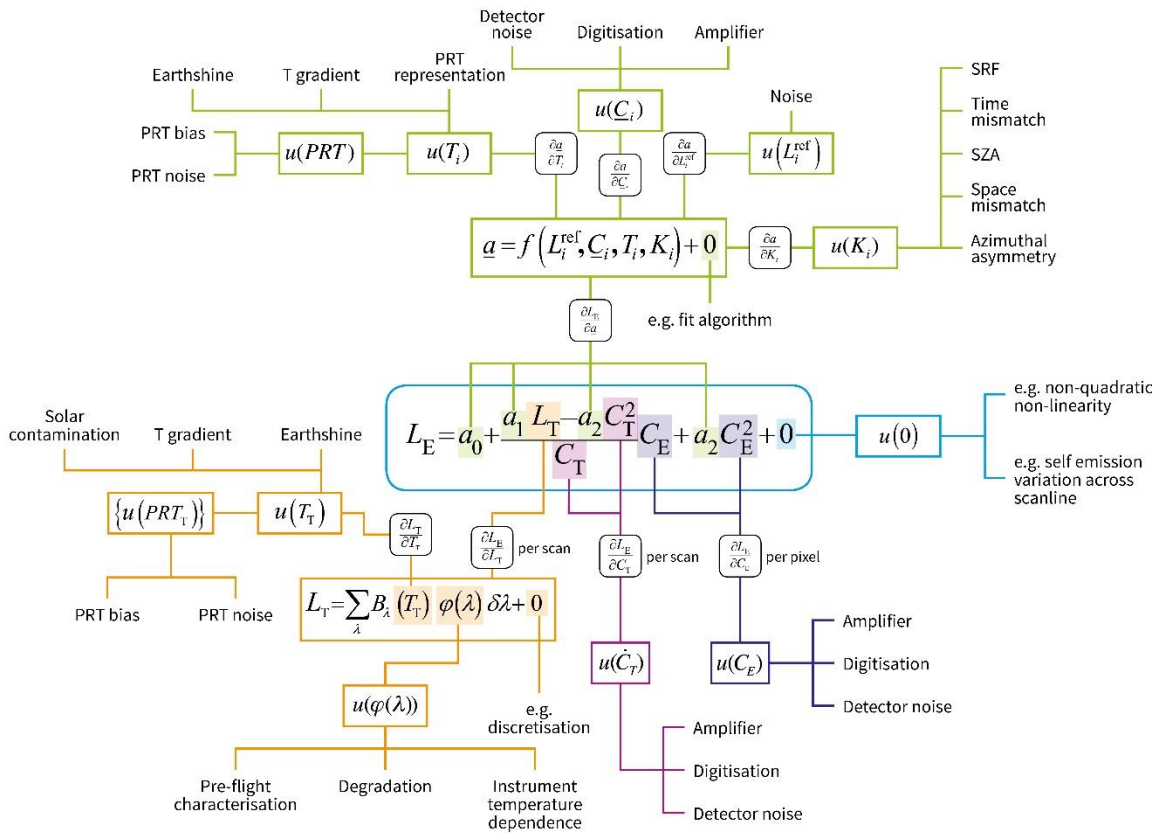

Figure 2 A simplified measurement function tree for AVHRR

3.3.3 Similar effects, common errors and correlations between quantities in the measurement function

As far as possible, the measurement-function-centred diagram should be prepared so that an effect affects only one quantity in the measurement function. We need to distinguish “similar effects” and “common errors”. For example, both the Earth count and the dark signal count (e.g. space view) will be sensitive to “detector noise”. Furthermore, because the Earth count is measuring a changing target, it may not be possible to estimate the scale of “detector noise” directly from the Earth count signal and we may use the dark signal count (which has more truly repeat measurements) to estimate the noise on both Earth and dark signals⁶. However, while this gives them a common uncertainty, this does not mean that they have a common error because the actual noise error on any one Earth count measurement will be independent of the actual noise error on any one dark signal count (see Appendix A).

Where two quantities in the measurement function rely on exactly the same instance of the same information we have a common error. This may come in artificially through the introduction of simplification quantities. For example, in the HIRS measurement function we write

$$L_E = \alpha (C_E - \bar{C}_S) + a_2 (C_E^2 - \bar{C}_S^2) - (L_{\text{self,E}}(T_{\text{inst}}) - L_{\text{self,S}}(T_{\text{inst}})) + a_4 + 0 \quad \text{Eq 3-1}$$

where α is defined by

⁶ A quantity that could be changing in time, and therefore be calculated as a function of time

$$\alpha = -\frac{\tilde{L}_{\text{IWCT}} + L_{\text{self,IWCT}}(T_{\text{inst}}) - L_{\text{self,S}}(T_{\text{inst}}) - a_2(\bar{C}_{\text{IWCT}}^2 - \bar{C}_{\text{S}}^2)}{\bar{C}_{\text{IWCT}} - \bar{C}_{\text{S}}}. \quad \text{Eq 3-2}$$

Clearly there are common quantities between α and other terms such as \bar{C}_{S} and $L_{\text{self,S}}(T_{\text{inst}})$, but we also note that this is simply a space-saving way of writing the full measurement function and such correlations are easily handled by calculating sensitivity coefficients, such as $\frac{\partial L_{\text{E}}}{\partial \bar{C}_{\text{IWCT}}}$ in full⁷.

There are some cases where such a process is more subtle. For example, in the MVIRI measurement function we have the solar zenith angle, θ , which in turn is calculated from the solar declination, the latitude and the local hour angle. Both the solar declination and the local hour angle are determined from the acquisition time and therefore any error in that acquisition time is common to both the solar declination and local hour angle. Therefore these two parameters are correlated. To avoid handling this correlation, however, we can consider the errors in the fundamental parameters – acquisition time, longitude and latitude – as the effects, and determine the sensitivity coefficient for the solar zenith angle to those three more fundamental parameters, even if computationally, and for understanding the process, it is easier to use the intermediate parameters.

Sometimes, however, it is impossible to separate the effects so that each effect affects only one quantity in the measurement function. This is the case if two quantities were determined from the same base information, for example through a fitting process, or where the explicit relationships cannot be written in full. This is most importantly true for harmonisation, which is considered separately in Section 6, but also for things such as the uncertainty associated with the spectral response function.

We do not anticipate many effects that are common to multiple terms in the measurement equation. When they arise, these can be handled by including all these terms in the description of the “affected term in the measurement function” and accounting for the multiple terms in deriving the sensitivity coefficient for that effect.

3.4 Simplifications in the presentation of the FCDR

3.4.1 Linear assumptions

The FCDR is provided in a simplified manner. Most fundamentally, we assume the applicability of the GUM Law of Propagation of Uncertainty,

$$u^2(y) = \mathbf{C} \mathbf{U} \mathbf{C}^T \quad \text{Eq 3-3}$$

where, \mathbf{C} is a (row) vector of sensitivity coefficients, $\partial f / \partial x_i$, and \mathbf{U} is an error covariance matrix for the input parameters, x_i and the relationship is given by Eq 2-1. In the special case where the input parameters (for a given pixel) are metrologically independent (have no common error effect, i.e. no error correlation), this is equivalent to a sum in quadrature of the uncertainties:

⁷ In this specific example there is also a nominal error correlation between $L_{\text{self,IWCT}}(T_{\text{inst}})$ and $L_{\text{self,S}}(T_{\text{inst}})$ because both depend on the instrument temperature. But this instrument temperature here is being used as a proxy for a more complex dependence and is taken to have no uncertainty in and of itself. See HIRS document for more details.

$$u^2(y) = \sum_{i=1}^n \left(\frac{\partial f}{\partial x_i} \right)^2 u^2(x_i). \quad \text{Eq 3-4}$$

Thus, in the metrologically independent case, the uncertainty associated with the measurand (radiance or reflectance) for that pixel can be given by adding in quadrature the uncertainty associated with each effect (Section 5.3) multiplied by the sensitivity coefficient (Section 5.4). See Section 7 for a discussion on how the uncertainty and covariance are calculated from the effects table.

The GUM discusses this Law of Propagation of Uncertainty and describes how it is based on a first-order Taylor series approximation of $Y = f(X_1, X_2, \dots, X_N)$ (Eq 2-1) about the estimates x_i of the quantities X_i . Such an approximation assumes that within the uncertainty of each input quantity the measurement function can be considered sufficiently linear. The GUM does provide guidelines on how to extend the Law of Propagation of Uncertainty to nonlinear cases⁸, but in the FIDUCEO effects tables this linear approximation is assumed.

Choices can, and should, be made to make the locally linear approximation to the measurement function implicit in Eq 3-3 as valid as possible. For example, ultimately in the FCDRs for AVHRR and HIRS we will present measured values as brightness temperatures, but the measurement function is close to linear in radiance. For this reason, we write the measurand of the measurement function for these FCDRs as radiance rather than brightness temperature.

3.4.2 Uncertainty distributions

The GUM Law of Propagation of Uncertainty summarises the probability distribution of each input quantity by its expectation and standard deviation. Such a summary may not be adequate for highly asymmetrical uncertainty distributions. See also Section 5.3.

3.4.3 Correlation forms

Real effects may have complex, or unknowable, forms of correlation. Here we make the approximation that the correlation structure can be sufficiently well represented by one of a set of standard correlation forms discussed in Section 4.

4 Error correlation form definition

4.1 Error correlation dimensions

A core concept behind the FIDUCEO FCDRs is the definition of error correlations between different observations so that this information can be used in the propagation of uncertainties to climate data records. In FIDUCEO we consider that errors may be correlated across a set of identified dimensions.

⁸ A particularly important example is for a function including $\cos(x_i)$ evaluated around $x_i = 0$ where the first order sensitivity coefficient is zero and a higher order approximation is required.

Error correlations between the same observed pixel (same time/location⁹) in different spectral bands/channels are defined separately; see Section 5.5.

For the spatial and temporal dimensions, the appropriate error correlation dimensions depend on the imaging method of the instrument.

For low Earth orbit (LEO) platforms with across-track scanning, we have concluded that the most useful error correlation dimensions are:

- Pixel-to-pixel within a scanline (from one pixel to any other pixel in the scanline)
- Scanline-to-scanline within an orbit (from one scanline to other scanlines in the orbit for a particular pixel)
- Orbit-to-orbit within a few orbits (from one orbit to the (countable) orbits immediately before/after that orbit, for the same scanline within that orbit)
- Time-to-time over a longer duration (from one week, month or year (to be defined) to other weeks, months, years; for “slow” systematic effects¹⁰)

Effects can have different correlation structures for different dimensions. For example, a calibration performed once per scanline, with some rolling average between scanlines, would yield effects that would be fully correlated (systematic) for all pixels within a scanline and would have a triangular correlation from scanline to scanline over an averaging window and would be uncorrelated (random) beyond those scanlines and from orbit to orbit.

An error in a correction such as the antenna pattern correction for microwave sensors would have a local correlation for nearby pixels within a scanline but would be random for pixels on the other side of the scan and it would be fully systematic from one scanline to the next, and from one orbit to the next for the same pixel position.

An error caused by an insufficient correction of solar radiation hitting the instrument or an on-board calibration target at a particular point in the orbit would be fully correlated for all pixels in the affected scanlines, correlated for the affected scanline range (but not to other scanlines) and would be highly correlated from one orbit to the next few orbits. It could, however, be highly variable (and to a greater or lesser degree, random) over much longer timescales as the orbital parameters drift.

For Geostationary Orbit Satellites (GEO) that take images in scanlines, the error correlation dimensions are slightly different:

- Pixel-to-pixel within a scanline (from one pixel to any other pixel in the scanline)
- Scanline-to-scanline within an image (from one scanline to other scanlines in the image for a particular pixel)
- Image-to-image within a few images (from one image to the (countable) images immediately before/after that image, for the same scanline within that image)

⁹ There are usually subtle differences in the exact spatial and temporal position of different spectral bands, for example where different spectral bands, and in some cases different spectral bands have very different spatial resolutions. In these cases, we interpret spectral error correlation as applying to pixels that are ‘near’ matches in time and space, and define ‘near’ in the accompanying documentation.

¹⁰ i.e. effects that repeat the same pattern of influence across pixels and scanlines in many orbits, but have some long-term drift

- Time-to-time over a longer duration (from one week, month or year (to be defined) to other weeks, months, years; for a 'slow' systematic effect)
- Time-to-time with a diurnal variation for effects that happen at certain solar angles

Within the FIDUCEO FCDR format we have defined attributes to represent:

- "pixel_correlation_scales"
- "scanline_correlation_scales"
- "time_correlation_scales"
- "image_correlation_scales"
- "orbit_correlation_scales"

It is not expected that all of these correlation scales would be used; in particular, it is unlikely that all three of "time", "image" and "orbit" would be used and the most appropriate one of these would be chosen.

Note further that for other sensors there may need to be other dimensions. For example for a push-broom scanner there may need to be some correlation form to represent correlations for a particular detector element or between detector elements. The "repeating rectangles" correlation form for the scanline correlation scale can be used to represent this, but it may be appropriate to consider defining a form for these cases in the future (when we have analysed such a sensor). More generally, as we investigate different sensors, the FIDUCEO error correlation dimensions may need to be expanded to include other possibilities.

4.2 Possible error correlation forms

Within any one of the dimensions described in Section 4.1, the error correlation can take different forms. This list does not attempt to describe every possible situation perfectly, but to have a menu of error correlation forms that are sufficiently close to those expected in reality that they can represent the expected error correlation in practical cases. The error correlation form describes the correlation coefficient between any two measured values in the dimension for which it is defined (section 7).

The defined error correlation forms are:

- **Random:** In this there is no error correlation with any other measured value.
- **Rectangular absolute (contains systematic):** In this the error correlation is constant for a particular range of values defined absolutely, rather than relative to the measured value. This includes the following cases:
 - Where a single measured value is used over an explicit range, e.g. where a single calibration value is used for all measurements over several scanlines, or in a particular year, and a different calibration value is used for all measurements outside that range.
 - For an effect that is fully systematic in that dimension (common to all measured values in that dimension). This is described with the dimensions $[-\infty, +\infty]$
- **Triangular relative:** In this the error correlation drops linearly (in the dimension of interest) relative to a particular measured value. This comes from a running average with constant weights. (See Appendix B.4 for an explanation of this correlation form).
- **Bell-shaped relative:** In this the error correlation drops faster than linearly (in the dimension of interest) relative to a particular measured value. This can come from:
 - A weighted running average (e.g. over neighbouring scanlines), which weights the central reading more than the others involved in the average.
 - Any other form of weighted averaging (e.g. through a spline fit in geolocation)

- Other cases where our expectation is that the correlation drops off over distance in some way.

In none of these cases is the error correlation form exactly Gaussian, but a truncated Gaussian form is a practical approximation for the Bell-shaped form, and is used. See Appendix B.4.4 for a discussion of why a truncated Gaussian is appropriate for a weighted average. What this correlation form represents is the situation where “nearby” errors are relatively highly correlated, but this correlation drops off over a distance. By defining the Gaussian width and the truncation range (beyond which there is no error correlation), it is possible to define a reasonable range of realistic correlation forms.

- **Repeating rectangles:** This comes from something for which the error correlation coefficient is constant within a small range (1 pixel or a range of pixels), then repeats on a regular cycle. It could come from a push-broom sensor where every n th scanlines are from a common detector element, or from a seasonal affect that occurs annually.
- **Repeating bell-shapes:** This is another repeating effect, but one where locally there is a drop off of correlation (partially correlated with neighbouring pixels/scanlines) which then has a repeating effect.
- **Stepped triangle absolute:** This accounts for the situation in HIRS where there is a calibration cycle, so that the instrument measures the calibration target once every 48 scanlines, and then there is a rolling average between scanlines. The correlation to neighbouring scanlines takes the form of a stepped triangle. See Appendix B.4.5 for a discussion of this correlation form.
- **Other:** Although true correlation structures may be more complicated than the ones given above, the above are sufficiently representative for the correlation structures encountered in FIDUCEO thus far. However, there may be situations where an FCDR producer needs to define a new error correlation form.

Depending on the type of error correlation form, different information is required. This is listed in Table 1, below.

Table 1 Parameters defined for different correlation forms

Correlation form	Parameters	Description
random	none required	For fully random effects there is no correlation with any other pixel
rectangle_absolute	<p>[-a,+b] (rectangle limits). Provide these per pixel/scanline/orbit as required. Allow for a way of representing</p> <p>[-∞,+∞]</p> <p>[rmax] States correlation coefficient for all pixel / scanline / orbit pixels. Default is rmax = 1 (fully correlated)</p>	<p>An effect is systematic within a range and different outside that range. For each pixel / scanline / orbit in range say number of pixels / etc either side that it shares a correlation with. For fully systematic effects notation to say “systematic with all”.</p> <p>If rmax is defined, then the correlation coefficient is one for the pixel with itself, and is rmax with all other pixels.</p>

<p>triangle_relative</p>	<p>[n] – number of pixels/scanlines being averaged in simple rolling average (should be an odd number)</p>	<p>Suitable for rolling averages over a window from $(-n-1)/2$ to $(+n-1)/2$ (i.e. for n pixels/scanlines being averaged) Assumes a simple mean, not a weighted mean.</p> <p>No rmax is needed, since it is always 1.</p>
<p>bell_shaped_relative</p>	<p>[n] – number of pixels being averaged in a weighted rolling average, from which truncation range and standard deviation for Gaussian representation follow (truncation beyond $\pm n$ pixels,</p> $\sigma = \frac{n/2-1}{\sqrt{3}}$ <p>(n should be odd)</p> <p>OR</p> <p>[n,sigma] n: truncation from $-n$ to $+n$, sigma: width of Gaussian representation</p> <p>(n should be odd)</p> <p>Typically provided once per orbit file (some further consideration needed about first/last scanlines in an orbit)</p>	<p>Suitable for rolling averages over a window from $(-n-1)/2$ to $(+n-1)/2$ (i.e. for n pixels/scanlines being averaged). Assumes a weighted mean, for any weights (and thus also includes things like spline fitting).</p> <p>Also suitable for anything else where the assumption is that “closer pixels/scanlines are more correlated than further pixels”. This can use two terms – n gives the truncation range outside which the assumption is there is no (or negligible) correlation, and sigma gives how fast the correlation drops off.</p> <p>The derivation of the width sigma to use for a weighted rolling average is given in Appendix B.4.4.</p>
<p>repeating_rectangles</p>	<p>[-a,+b,rmax,L,h,imax] per pixel/scanline/orbit etc (rmax,L,h will be same for different pixels)</p>	<p>Correlation coefficient assumed to be rmax for pixels/scanlines from $-a$ to $+b$, and h for pixels/scanlines from $L-a$ to $L+b$ and from $2L-a$ to $2L+b$ and so on ($iL-a$ to $iL+b$) for all integers i up to imax.</p>
<p>repeating_bell-shapes</p>	<p>[n,sigma,L,h, imax]</p>	<p>Correlation coefficient assumed to drop off as a truncated Gaussian for local pixels/scanlines etc in the range defined by n and a similar Gaussian with a peak of h and the same width for pixels/scanlines iL pixels apart on either side, for all integers i up to imax.</p>

Stepped_triangle_absolute	[-a,+b,n] per pixel/scanline/orbit etc (n will be same for different pixels)	The step is a rectangular absolute from -a to +b with a correlation coefficient of one, after which the correlation coefficients drops for another a+b+1 lines, and then again. n is the number of calibration windows averaged. See Appendix B.4.5
Other	A function describing the correlation	Not yet implemented.

5 The Effects table

5.1 Effects table overview

The effects table takes the form shown in Table 2.

Table 2: Table for codifying the correlation structure in L1 radiances

Table descriptor		How this is codified	Notes
Name of effect		A unique name for each source of uncertainty in a term of the measurement function	If a similar effect is present for several terms, the names should be unique, e.g. earth count noise, ICT count noise
Affected term in measurement function		Name and standard symbol of affected term	Usually an effect will only affect a single term, though there may be exceptions, see Section 3.3.3.
Instruments in the series affected		Identifier of the specific instrument / satellite platform where this effect matters	Some effects may only apply to certain instruments in an FCDR series, or may take a different correlation form for different instruments
Correlation type and form	Pixel-to-pixel [pixels]	One of the types defined in Section 4.2: provided by name	Images is for GEO satellites, Orbits for LEO satellites. Time is a more general quantity and needs an associated attribute describing the unit (e.g. day, week, month, year, epoch)
	from scanline to scanline [scanlines]		
	between images [images]		
	Between orbits [orbit]		
	Over time [time]		
Correlation scale	Pixel-to-pixel [pixels]	In units of pixels, scanlines, time or images/orbits –	See Section 3.4.2.
	from scanline to scanline		

	[scanlines] between images [images] Between orbits [orbit] Over time [time]	what is the scale of the correlation shape?	The parameters defined for the particular type and form provided here are as specified in Table 1.
Channels/bands	List of channels / bands affected	Channel names in standard form	Some effects may only affect certain channels
	Error correlation coefficient matrix	A matrix	See Section 5.5
Uncertainty	PDF shape	Functional form of estimated error distribution for the term	See Section 5.3
	units	Units in which PDF shape is expressed (units of term, or can be as percentage etc)	See Section 5.3
	magnitude	Value(s) or parameterisation estimating width of PDF	See Section 5.3
Sensitivity coefficient		Value, equation or parameterisation of sensitivity of measurand to term	See Section 5.4

5.2 Correlation forms

The correlation form will be one of the forms described in Section 4.2. The correlation scale provides the parameters needed to describe that form, see Table 1.

5.3 Uncertainty

The uncertainty (“magnitude” row) is the standard deviation of the estimated PDF of the error in the relevant term of the measurement function. It is always a standard uncertainty (one standard deviation, and never an expanded uncertainty, e.g. for $k = 2$). The uncertainty will usually have the units of the effect, although in some cases uncertainties may be expressed in percentage.

The PDF shape will be one of a defined list of shapes. As with the correlation form, the actual PDF may not fit perfectly to one of these shapes, but they are likely to be sufficiently close to most actual PDFs.

Table 3 describes common PDF shapes and what the standard uncertainty (the value in “magnitude” under uncertainty in the Effects tables) refers to.

Table 3 Parameters defined for different PDFs. For an explanation of these standard uncertainty values, see the GUM section 4.4.

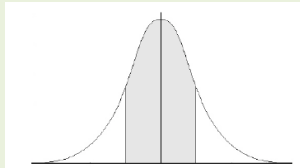
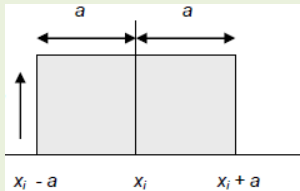
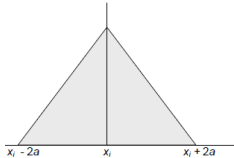
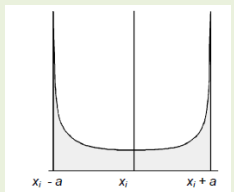
PDF shape	What is the standard uncertainty	Description
Gaussian 	$u = \sigma$	Be careful when using published literature, or a calibration certificate, to provide u . If an expanded uncertainty is quoted, then it's important to divide by k (often $k=2$ in literature).
Digitised_Gaussian	Unknown	We have not performed sufficient analysis to determine the most appropriate standard uncertainty for a digitised Gaussian. For now treat as a Gaussian, but keep this option open for the future
Rectangle 	$u = a/\sqrt{3}$ where a is the half width	Useful for when we know a quantity must be in a range $\pm a$, but it's equally likely to be anywhere in that range, e.g. digitisation
Triangular 	$u = a/\sqrt{6}$ where a is the half base	Useful for where we know there is a range a quantity is in but it's more likely to be in the middle of that range (e.g. when a quantity is the difference between two digitised values)
U-distribution 	$u = a/\sqrt{2}$ where a is the half base	Useful for where we know there is a range a quantity is in but it's more likely to be at the edges of that range (e.g. where there is a feedback loop that switches on and off and encourages drift to the two ends of a temperature range)
Other		If the PDF is not one of these, but a standard uncertainty can be provided, then this is also

		acceptable, a note should be added in documentation.
--	--	--

5.4 Sensitivity coefficients

The sensitivity coefficient translates the uncertainty associated with the effect, in the units given in the “uncertainty units” row into an uncertainty associated with the measurand (e.g. Earth radiance). Normally, this would be given by the partial derivative $\partial f / \partial x_i$, which may be best defined in terms of a chain rule (see examples in the D2-2 FCDR documents).

Note that if the uncertainty is expressed in %, this should also include multiplying the partial derivative sensitivity coefficient by the value to obtain absolute, rather than relative uncertainties.

Where the sensitivity coefficient is best expressed as an equation, this can be provided to the code as a virtual variable. In some cases it may be more efficient (or only possible) to provide a value for each pixel. There may be some occasions when the sensitivity coefficient has not been determined by analytical differentiation, for example where the form of the relationship is not known but deduced from modelling or analysis of real data (or pre-flight experimentation). In these cases the sensitivity coefficient should be provided as a value for each pixel (or scanline or orbit).

5.5 Correlation between channels

The correlation between channels is given as a correlation coefficient matrix. Note that an effect can be fully correlated between channels (were you to know the error in one channel you could predict the error in another channel) and have a different uncertainty for different channels. For example, a temperature error on an internal warm calibration target acting as a pseudo blackbody would affect all spectral channels, but would cause a larger error for shorter wavelength channels than for longer wavelength channels. This difference is handled by the sensitivity coefficient. See also Section 7.

5.6 Coding the effects table

The FIDUCEO deliverable D3.1 “CDR/FCDR File Format Specification” by Tom Block and Sabine Embacher provides information on how the FCDR effects table is coded.

6 Harmonisation and harmonisation coefficients

A discussion of the process of harmonisation is being separately prepared in a different document. This section therefore only touches on some key aspects of harmonisation.

6.1 Information required for harmonisation

Harmonisation is a process that takes in “match ups” (occasions when two satellites in the series or a satellite in the series and a reference satellite saw the same ground location at the same time, within agreed match up limits) and uses these to determine the harmonisation coefficients in the measurement function. As discussed in Section 3.2.5, these harmonisation coefficients generally refer to physical attributes of an instrument that can be better estimated from the harmonisation process than from available pre-flight or on-board calibration information and harmonisation can be considered a recalibration of the sensor.

Harmonisation requires the form of the measurement function and all the quantities within the measurement function (e.g. counts, on board calibration process values) for the sensor (or sensors¹¹) for each match-up. In addition, it is necessary to provide the harmonisation process with the error correlation structure for these quantities from match-up to match-up.

Such analysis can very much be informed by the effects tables, and more so, by the thinking behind the effects tables, but it cannot use the information in the effects tables directly. This is for two reasons:

- First, harmonisation requires raw values of the terms on the right hand side of the measurement function. In other words it requires, for example, counts and temperatures. The effects tables have sensitivity coefficients that convert to Earth radiance values. These would not be the correct sensitivity coefficients for harmonisation¹².
- Second, the correlation between two match-ups depends on how “far” apart those match ups are in all the dimensions considered in the effects table. This has to be separately considered and that information provided to the harmonisation routine.

The harmonisation software requires the input of a “W-matrix” that describes the correlation structure of the input parameters to the harmonisation process from match-up to match-up. A full description of how the W-matrix is formed is given elsewhere [Hunt et al 2017].

6.2 Covariance associated with the harmonisation coefficients

The harmonisation process provides the harmonisation coefficients and a covariance matrix for those harmonisation coefficients (i.e. the covariances between the harmonisation coefficients). Note that there will almost always be covariances between the different harmonisation coefficients. To propagate this through to the FCDR radiance values we additionally need the sensitivity coefficients of the FCDR measurand (Earth radiance) to these coefficients.

The harmonisation coefficients are always fully correlated for all measurements in a single spectral channel for a single sensor. There is also a correlation between the harmonisation coefficients of different sensors in the FCDR series that will be known from the harmonisation process.

The correlation between spectral channels due to harmonisation has not yet been considered; there will be some correlation.

6.3 Coding information on the harmonisation coefficients

In the generation of the full-FCDR, information about the harmonisation coefficients and their covariance must also be codified. This has not yet been analysed.

¹¹ Where the match-up is to the reference, the reference provides only a radiance and only the other sensor needs all the parameter values; where the match-up is sensor-to-sensor for the series of interest, then the raw count and other parameter values for both sensors are needed.

¹² In particular, if the effect is a sub-effect of a quantity in the measurement function. For example, if the PRT noise in an onboard calibration target is considered, then this will have an uncertainty in PRT counts or kelvin and the sensitivity coefficient in the effects table will convert this to Earth radiance. For harmonisation, however, we are interested in the covariance for the calibration target radiance, for which a different sensitivity coefficient is needed.

7 Using the FCDR effects table

7.1 The uncertainty associated with a single observation in a single channel at a single pixel

With the Law of Propagation of Uncertainty and its linear approximation (see Section 3.4.1), the uncertainty associated with a single observation in a single channel at a single pixel/time $L_{E,t}$ is given from the variance:

$$u^2(L_{E,t}) = \underbrace{\sum_{i=1}^n \left(\frac{\partial L_{E,t}}{\partial x_i} \right)^2 u^2(x_i)}_{\text{effects table effects}} + \underbrace{\sum_{j=1}^m \left(\frac{\partial L_{E,t}}{\partial a_j} \right)^2 u^2(a_j)}_{\text{harmonisation coefficients variance}} + \underbrace{2 \sum_{j=1}^{m-1} \sum_{k=j}^m \left(\frac{\partial L_{E,t}}{\partial a_j} \right) \left(\frac{\partial L_{E,t}}{\partial a_k} \right) u(a_j, a_k)}_{\text{harmonisation coefficients covariance}} \quad \text{Eq 7-1}$$

Here the first summation is over the n effects with an effects table, each treated as metrologically independent of each other, with uncertainty $u(x_i)$ and sensitivity coefficient $\frac{\partial L_{E,t}}{\partial x_i}$ obtained from the effects tables. The harmonisation coefficients are treated by the other two terms.

7.2 The covariance associated with observations in different channels at a single pixel

Here we make the assumption that there is negligible correlation from channel-to-channel for the error in harmonisation coefficients (the validity of this assumption needs further consideration once we have more experience with harmonisation).

See Appendix B for a detailed consideration of the error correlation.

The effects tables provide a correlation coefficient matrix, \mathbf{R} , representing, for that effect, what the correlation between channels is (in the effects table the row labelled “channels/bands: error correlation coefficient matrix”). These will usually, but not always, be either a diagonal matrix with ones down the diagonal, and zeroes elsewhere, or a matrix that is one everywhere.

The effects table (in the row “uncertainty: magnitude”) will provide the uncertainty associated with the effect quantity. For effects that are uncorrelated from channel to channel, this will be channel dependent. For effects that are correlated from channel to channel this will be the same value for each channel.

The effects table (row: sensitivity coefficient) will provide the sensitivity coefficient for the measurand (Earth radiance) with respect to the effect. This is likely to be provided as a virtual variable, in other words in the form of an equation described in code. This will almost certainly be different for the different channels.

The covariance matrix associated with observations in different channels at a single pixel is therefore given by

$$U_{\text{ch}} \equiv \begin{pmatrix} u^2(L_{E,\text{ch}1}) & u(L_{E,\text{ch}2}, L_{E,\text{ch}1}) & \cdots & u(L_{E,\text{ch}_i}, L_{E,\text{ch}1}) \\ u(L_{E,\text{ch}1}, L_{E,\text{ch}2}) & u^2(L_{E,\text{ch}2}) & \cdots & u(L_{E,\text{ch}_i}, L_{E,\text{ch}2}) \\ \vdots & \vdots & \ddots & \vdots \\ u(L_{E,\text{ch}1}, L_{E,\text{ch}_i}) & u(L_{E,\text{ch}2}, L_{E,\text{ch}_i}) & \cdots & u^2(L_{E,\text{ch}_i}) \end{pmatrix} \quad \text{Eq 7-2}$$

$$U_{\text{ch}} = \sum_{\text{effects}, i} C_i V_i R V_i C_i \quad \text{Eq 7-3}$$

where the sum is over all effects with an effects table. The rows and columns of the matrices represent the different channels. \mathbf{C}_i is a diagonal matrix with the sensitivity coefficients for that effect per channel down the diagonal and zeroes elsewhere. \mathbf{V}_i is a diagonal matrix with the uncertainties associated with the effect (in its native units, i.e. the ones in the effects table) down the diagonal and zeroes elsewhere¹³ and \mathbf{R}_i is the correlation coefficient matrix given in the effects table for channel-to-channel correlations.

For example (see also Appendix B), consider the error in the temperature of the internal warm calibration target for a thermal infrared or microwave sensor. This may have a common error, say 0.1 K, which affects all channels. For the example of a three-channel instrument, we can write, for this effect:

$$\mathbf{C}_T \mathbf{V}_T \mathbf{R}_T \mathbf{V}_T \mathbf{C}_T = \begin{pmatrix} \frac{\partial L_{E,\lambda 1}}{\partial T} & 0 & 0 \\ 0 & \frac{\partial L_{E,\lambda 2}}{\partial T} & 0 \\ 0 & 0 & \frac{\partial L_{E,\lambda 3}}{\partial T} \end{pmatrix} \begin{pmatrix} u(T) & 0 & 0 \\ 0 & u(T) & 0 \\ 0 & 0 & u(T) \end{pmatrix} \begin{pmatrix} 1 & 1 & 1 \\ 1 & 1 & 1 \\ 1 & 1 & 1 \end{pmatrix} \begin{pmatrix} u(T) & 0 & 0 \\ 0 & u(T) & 0 \\ 0 & 0 & u(T) \end{pmatrix} \begin{pmatrix} \frac{\partial L_{E,\lambda 1}}{\partial T} & 0 & 0 \\ 0 & \frac{\partial L_{E,\lambda 2}}{\partial T} & 0 \\ 0 & 0 & \frac{\partial L_{E,\lambda 3}}{\partial T} \end{pmatrix} \quad \text{Eq 7-4}$$

Considering additionally another effect, say Earth count noise, that is random from channel to channel, that would be (condensed notation for uncertainty used to save space):

$$\mathbf{C}_{CE} \mathbf{V}_{CE} \mathbf{R}_{CE} \mathbf{V}_{CE} \mathbf{C}_{CE} = \begin{pmatrix} \frac{\partial L_{E,\lambda 1}}{\partial C_E} & 0 & 0 \\ 0 & \frac{\partial L_{E,\lambda 2}}{\partial C_E} & 0 \\ 0 & 0 & \frac{\partial L_{E,\lambda 3}}{\partial C_E} \end{pmatrix} \begin{pmatrix} u_{C_{E,\lambda 1}} & 0 & 0 \\ 0 & u_{C_{E,\lambda 2}} & 0 \\ 0 & 0 & u_{C_{E,\lambda 3}} \end{pmatrix} \begin{pmatrix} 1 & 0 & 0 \\ 0 & 1 & 0 \\ 0 & 0 & 1 \end{pmatrix} \begin{pmatrix} u_{C_{E,\lambda 1}} & 0 & 0 \\ 0 & u_{C_{E,\lambda 2}} & 0 \\ 0 & 0 & u_{C_{E,\lambda 3}} \end{pmatrix} \begin{pmatrix} \frac{\partial L_{E,\lambda 1}}{\partial C_E} & 0 & 0 \\ 0 & \frac{\partial L_{E,\lambda 2}}{\partial C_E} & 0 \\ 0 & 0 & \frac{\partial L_{E,\lambda 3}}{\partial C_E} \end{pmatrix} \quad \text{Eq 7-5}$$

The resultant matrices from Eq 7-3 would be added together (along with those from other effects) as in Eq 3-4, to obtain the variance (diagonal elements) and covariance of the Earth radiance from channel to channel due to this effect.

7.3 The uncertainty associated with observations in a single channel at different pixels

A similar process is followed when considering the covariance between different pixels in an observation set. Each effect can be considered separately and be added together (the minor extension for the harmonisation coefficients has not yet been thought through, but will be later in the project).

Thus for each effect we need the matrices

- \mathbf{C}_i , which is a diagonal matrix of sensitivity coefficients for each of the pixels we're interested in. The sensitivity coefficients are determined directly from the effects table.
- \mathbf{V}_i , which is a diagonal matrix of uncertainties associated with the effect for the pixels we're interested in, which can be read directly from the effects table.

¹³ Note that this will be the same number in each diagonal element for systematic effects.

- \mathbf{R}_i , which is the correlation coefficient matrix containing the correlation coefficients associated with the effects for the pixels we're interested in.

To calculate the correlation coefficient between a pair of pixels, and hence the matrix \mathbf{R}_i , we need:

- The separation between pixels in each of the correlation dimensions
- The type of correlation in each of the correlation dimensions
- The correlation scale in the different dimensions

This will be discussed further in later work (it is the responsibility of the deliverable D2-4). As a starting point, consider two pixels in the same scanline.

- If the correlation form pixel-to-pixel is random, then the correlation coefficient is 0
- If the correlation form pixel-to-pixel is rectangular absolute, then the correlation coefficient is $\max(1 - |r|, 0)$ if they are within each other's range and 0 if they are outside each other's range
- If the correlation form pixel-to-pixel is triangular relative, then the correlation coefficient is given by a triangular function (see Appendix B.4.4).
- If the correlation form pixel-to-pixel is bell-shaped, then the correlation coefficient is approximated by the corresponding truncated Gaussian function (see Appendix B.4.4).

Note that this will be further complicated if the pixels are separated in all dimensions simultaneously and there are different correlation forms in each scanline. This will be discussed further in the future work of deliverable D2-4.

8 Conclusions

This report has discussed the nature of the effects table and how an FCDR producer should think about filling it in. We recommend starting with the measurement function diagram, considering, as far as possible, how to make the different effects metrologically independent (that is with no common error between effects). We have discussed how the effects table formally codifies the correlation information from pixel-to-pixel, from scanline-to-scanline, from orbit-to-orbit or image-to-image and over longer timescales. We've also discussed how the information is coded from channel-to-channel.

We have briefly introduced the concepts of harmonisation, which will be further developed in D2-3, and how the FCDR information will be used to determine the uncertainty between any two measured values, which will be further developed in D2-4.

Below are two appendices that further explain the concepts of errors and uncertainties (Appendix A) and that discuss the origin of the error correlation structures (Appendix B).

A Appendix on errors, uncertainties and correlation

A.1 Errors and uncertainties

The terms ‘error’ and ‘uncertainty’ are not synonyms, although they are often confused. To understand the distinction, consider the result of a measurement – the measured value. The value will differ from the true value for several reasons, some of which we may know about. In these cases, we apply a **correction**. A correction is applied to a measured value to account for known differences, for example the measured value may be multiplied by a gain determined during the instrument’s calibration, or a measured optical signal may have a dark reading subtracted. This correction will never be perfectly known and there will also be other effects that cannot be corrected, so after correction there will always be a residual, unknown **error** – an unknown difference between the measured value and the (unknown) true value.

The specific error in the result of a particular measurement cannot be known, but we describe it as a draw from a probability distribution. The **uncertainty** associated with the measured value is a measure of that probability distribution; in particular, the **standard uncertainty** is the standard deviation of the probability distribution.

Although errors are unknown, we can evaluate the uncertainty associated with the measured value. Any measurement is sensitive to several different sources of uncertainty, or ‘effects’, such as nonlinearity, non-uniformity, detector temperature sensitivity, etc. Each gives rise to an unknown error drawn from a probability distribution described by the uncertainty.

A.2 Error correlation and quantity correlation

Similarly, although the errors are unknown we can provide information on error correlation. Error correlation occurs when a specific (unknown) error is known to be the same for two different measured values. Note that only errors can be correlated. Uncertainties are never correlated, as the term “uncertainty” represents the spread of a distribution. Similarly, terms such as “systematic uncertainties” are at best shorthand for “uncertainties associated with systematic effects/errors” and at worst, confusing.

A.2.1 Random errors

The term ‘random error’ is used to imply independence, such that the error in $L_{\lambda',s',e'}$ is in no way predictable from knowledge of the error in $L_{\lambda,s,e}$, were that knowledge available.

In a laboratory, the uncertainty associated with random effects will usually be estimated from the standard deviation of repeated measured values. Some EO sensors have calibration systems that support an estimation of the magnitude of radiometric noise on similar principles, through repeated measurements of a stable calibration target. The standard deviation of measured values gives a noise estimate that is valid when viewing scene radiances similar to the calibration target radiance. Extrapolating this to other radiances (such as the ‘scene radiance’ seen when viewing the Earth) requires understanding of the physics of the sensor. A complication is that there may be insufficient repeat readings in a single calibration cycle to estimate the standard deviation reliably, especially since EO signals can be heavily digitised, and sometimes the digitisation step can be similar in magnitude to the noise.

The noise differs between channels, and may evolve over time as the instrument temperature changes, or as the instrument degrades through its mission life. Thus, the uncertainty associated with random effects may be evaluated as a time series.

A.2.2 Structured random errors

Structured random errors arise from random effects where the unknown error affects multiple pixels and/or channels. An example is a scanning sensor for which calibration against a target is performed once per scan. There is a random error in the measured target signal from sensor noise, and because the measured target signal is used to calculate the sensor gain applied to all Earth radiances within the scan line, the error introduced affects the measured radiances of all pixels in the scan line. This is a random effect (it cannot be corrected for, even in principle) that causes a fully correlated error across a set of pixels that have a known spatial structure in the image. In EO it is helpful to use this term to distinguish random errors that have predictable structure across an image.

A.2.3 Systematic errors

Systematic errors are errors that could in principle be corrected for if we had sufficient information. They include, but are not limited to, effects that are constant for a significant proportion of a satellite mission (biases). Other systematic errors vary on shorter timescales, and may be intermittent.

A.2.4 Error correlation and geophysical correlation

We have classified the effects by the correlation structure of the errors they cause. Uncertainty is neither random nor systematic, because uncertainty describes the error dispersion. Metrologists use phrases such as ‘the uncertainty associated with random effects’ when they want to describe the error correlation structure causing an uncertainty. Metrologists often avoid the word ‘error’ to bypass the confusion arising from incorrect uses ‘error’ and ‘uncertainty’ in much scientific literature. But, in reference to EO data, it is essential to distinguish correlations in measured radiances due to physical variability from correlations due to dependent errors. In this report, we therefore use the terms ‘random error’, ‘systematic error’, ‘error correlation’ and ‘error covariance’ intentionally and consistently.

A.3 Type A and Type B methods for evaluating uncertainty and correlation

“Type A” and “Type B” refer to definitions from the Guide to Uncertainty in Measurement. These are methods for evaluating uncertainties. Note that uncertainties are not classified as Type A or Type B, this represents the method for evaluating the uncertainty.

Type A is based on statistical analysis, Type B is based on expert judgement. Both types of uncertainty analysis are appropriate and a typical uncertainty analysis will use both approaches.

Type A methods use statistical observations and calculate a standard or Allan deviation to perform analysis of standard uncertainties and calculate a Pearson correlation coefficient to determine error correlation. Care must be taken to ensure that the sample is sufficiently representative of the full distribution.

Type B methods rely on other approaches, for example evaluating an uncertainty based on a simulation, or based on known limits. Type B methods are used when correlations are evaluated by considering common error effects.

B Appendix on error correlation and error covariance

B.1 Error correlation and covariance concepts

When we combine FCDR values from different pixels and/or from different spectral channels, we need to understand the covariance between the FCDR value in those pixels/channels. In FIDUCEO this is understood through the concept of effects and recorded in effects tables. We therefore are interested in knowing the covariance between the FCDR value (usually Earth radiance) in different channels / pixels due to each effect. As discussed in Section 7, this is given by equations similar to Eq 7-3 (which is for the covariance between the measured values in different channels for a single pixel). In general, the covariance matrix for the Earth radiance, due to an individual effect, i , is given by

$$U_i = C_i V_i R_i V_i C_i \quad \text{Eq 8-1}$$

where, C_i is a diagonal matrix with the sensitivity coefficients down the diagonal and zeroes elsewhere, V_i is a diagonal matrix with the uncertainties associated with the effect down the diagonal and R_i is the correlation coefficient matrix. The covariance matrix for Earth radiance due to all effects is obtained by adding up these individual effect covariance matrices (Eq 7-3).

Note 1: Covariance matrix: This covariance matrix is for the covariance of different FCDR values (e.g. Earth radiance, Earth reflectance) in different channels or in different pixels. The number of rows and columns in all the matrices in Eq 8-1 is defined by the number of pixels or channels that are being combined in the CDR generation.

Note 2: When this covariance is used in the evaluation of the uncertainty associated with a CDR, it will be multiplied by a sensitivity coefficient column vector for the sensitivity coefficients of the CDR to the individual Earth radiances (or reflectances). That would be a separate sensitivity coefficient vector to the one given here as C_i and would be the sensitivity of the CDR equation, not the FCDR equation.

Note 3: The sensitivity coefficient matrix C_i has as elements the sensitivity coefficient of the FCDR value (e.g. Earth radiance) evaluated at each pixel/channel to the effect i . These are partial derivatives and can account for the case where the effect has a full error correlation, but a different impact on different pixels or channels (see example).

Note 4: The uncertainty matrix V_i has, as elements, the uncertainties associated with the effect in native units (i.e. units of the effect, rather than units of the FCDR; the conversion is done by the sensitivity coefficients). Where an effect has a full error correlation, this uncertainty will be the same in all diagonal elements.

Note 5: The correlation coefficient matrix is the only matrix that is not diagonal in Eq 8-1. It will usually consist of 0s and 1s, representing no correlation and full correlation respectively. It will also always be symmetrical about the diagonal and the diagonal elements will always be 1.

As an example, consider the covariance matrix for different channels of a thermal infrared sensor for a single pixel due to the uncertainty associated with the temperature of an onboard calibration target. If all channels see the same target, then an error in temperature is common to all channels, but because shorter wavelengths are more sensitive to temperature than longer wavelengths, the uncertainty associated with the Earth radiance due to this effect is different from channel to channel. The effect is fully error correlated,

in the sense that if you were to know the error in one channel you would be able to predict the error in another channel perfectly, even though the error would be different.

In that thermal infrared sensor example, the covariance matrix is all 1s: the temperature error is common to all channels. The uncertainty matrix is a diagonal matrix with the uncertainty associated with temperature in kelvin in all diagonal elements (e.g. 0.1 K). The sensitivity coefficient matrix has as diagonal elements the values $\frac{\partial L_{E, \text{ch}_i}}{\partial T_{\text{IWCT}}}$. This will take a different value in each channel.

A similar expression can be formed when considering the covariance between a set of observed pixel values.

The covariance between a specific pair (j, k) of observations due to effect i , is (taking the off-diagonal element of the two-by-two covariance matrix for the pair)

$$u(L_{E,i,j}, L_{E,i,k}) = \frac{\partial L_{E,j}}{\partial x_i} \frac{\partial L_{E,k}}{\partial x_i} u(x_{i,j}) u(x_{i,k}) r(x_{i,j}, x_{i,k}) \cdot \quad \text{Eq 8-2}$$

B.2 Information required in the FCDR

In order to evaluate Eq 8-1 for a particular set of channels/pixels being combined in a CDR we therefore need the information on the uncertainty associated with the effect in its native units, the sensitivity coefficient for the FCDR measurand due to this effect for any channel or pixel and the correlation coefficient between channels/pixels.

This information is available from the effects tables. The sensitivity coefficient provided in the effects table can be evaluated for any pixel and channel. The uncertainty is given in the uncertainty row of the table. The correlation coefficient between spectral channels is given by a correlation coefficient matrix in the appropriate row of the effects table and the correlation coefficient between pixels is inferred from the correlation form and scale.

The FCDR producer therefore needs to determine the correlation coefficient matrix and/or the correlation form and scale. In the subsequent sections we discuss how this is done.

B.3 Derivation of correlation forms for spectral channels

B.3.1 Type A method to evaluate correlation

If we use a Type A method to evaluate correlation, then the correlation coefficient¹⁴ is calculated as

$$r(x, y) = \frac{\sum_{i=1}^n (x_i - \bar{x})(y_i - \bar{y})}{\sqrt{\sum_{i=1}^n (x_i - \bar{x})^2} \sqrt{\sum_{i=1}^n (y_i - \bar{y})^2}} = \frac{1}{n-1} \sum_{i=1}^n \left(\frac{x_i - \bar{x}}{s_x} \right) \left(\frac{y_i - \bar{y}}{s_y} \right) \cdot \quad \text{Eq 8-3}$$

¹⁴ This is the Pearson Correlation Coefficient and the terms have their standard meaning (see any standard statistics text book).

The final expression involves the standard deviation of the samples, i.e. s_x and s_y , which for white noise is the best estimate we have (in the absence of further information¹⁵) of the uncertainty associated with the noise.

Care must be taken in using Type A methods to ensure that we are really working out the error correlation and not just a correlation due to physical or geophysical processes. This means somehow distinguishing the error from the value, and this is only realistically possible if there is some way of independently estimating the error.

Good examples are the HIRS FCDR where this approach was used for noise on measurements of the internal warm calibration target (assumed to be stable, so that the difference from average could be considered a proxy for the error) and for the MVIRI FCDR on the geolocation error (which can be independently estimated from landmark positions).

B.3.2 Channel-to-channel correlations

In almost all cases, except for those for which a Type A method is used (Appendix B.3.1), the channel-to-channel correlation matrix will consist entirely of 0s and 1s. 0 where the error is not common between channels and one where it is. The FCDR producer must simply evaluate whether the error is common. Note the warnings that an effect can have a common uncertainty, or a similar effect, but not a common error if the error in one channel is drawn independently from a common distribution, say different channels have different amplifier noise error, even though they have the same amplifier and the same method is used to determine the uncertainty. Note also that because of the sensitivity coefficient a common error may affect the FCDR measurand differently for different channels.

B.4 Pixel-to-pixel correlation forms

B.4.1 Type A methods

It is also possible to use Type A methods (Appendix B.3.1) with pixel-to-pixel correlation. In these cases this should be used usually to define the scale of one of the standard correlation forms, e.g. a bell-shaped distribution. The effects tables do allow for an “other” correlation form to be defined should that be necessary.

B.4.2 Rectangular absolute

For a rectangular absolute correlation form, the correlation coefficient is r_{max} (usually 1) within the absolute window and 0 outside it.

B.4.3 Deriving the triangular correlation form for a simple rolling average

A simple rolling average over $n = 2m + 1$ scanlines (from m scanlines before to m scanlines after) has a correlation coefficient that takes the form of a triangle of peak 1 and full base $2n$.

¹⁵ Useful further information may include the standard deviations of these deviations over a wider temporal range. It may also be more appropriate to use the Allan Deviation (see Mittaz (2016), Allan (1966))

To derive this, we can calculate the covariance between two averages \bar{X}_i and \bar{X}_j . Note that for the purposes of this derivation we use the covariance between the averages, not the covariance between the measurand due to the quantity that is averaged.

The averages are described by

$$\bar{X}_i = \frac{1}{n} \sum_{k=i-m}^{i+m} x_k, \quad m = (n-1)/2 \quad \text{Eq 8-4}$$

So the covariance between the average centred on i and the average centred on j , Eq 8-2, is

$$u(\bar{X}_i, \bar{X}_j) = \sum_h \frac{\partial \bar{X}_i}{\partial x_h} \frac{\partial \bar{X}_j}{\partial x_h} u^2(x_h) \quad \text{Eq 8-5}$$

where the sum is over all x_h that are common between the two averages (i.e. over every common element in the averages, Eq 8-4).

All the partial derivatives are the same, $\frac{\partial \bar{X}_i}{\partial x_h} = \frac{\partial \bar{X}_j}{\partial x_h} = \frac{1}{n}$, so

$$u(\bar{X}_i, \bar{X}_j) = \frac{1}{n^2} \sum_h u^2(x_h) \quad \text{Eq 8-6}$$

If the two averages are identical, so that $i = j$, we have the standard uncertainty associated with a simple mean¹⁶:

$$u(\bar{X}_i, \bar{X}_i) = u^2(X_i) = \frac{1}{n^2} \sum_h u^2(x_h) = \frac{n}{n^2} u^2(x_h) = \left(\frac{u(x_h)}{\sqrt{n}} \right)^2 \quad \text{Eq 8-7}$$

If the two averages do not overlap, then the covariance is zero as there are no common components x_h .

If the two averages overlap partially, so that $|i - j| \leq n$, then we have $n - |i - j|$ common components. Then, we can write

$$u(\bar{X}_i, \bar{X}_j) = \frac{1}{n^2} \sum_h u^2(x_h) = \frac{n - |i - j|}{n^2} u^2(x_h), \quad \forall |i - j| \leq n \quad \text{Eq 8-8}$$

We can consider this graphically by graphing the weight of each value in each average as two rectangles. As the rectangles start to overlap, we get the overlap integral for those rectangles. This will take the form of a triangle, as given by Eq 8-8.

To get the correlation coefficient we divide by the uncertainties

¹⁶ We make the reasonable assumption that the uncertainty associated with each element within the averaging window is the same.

$$r(\bar{X}_i, \bar{X}_j) = \frac{u(\bar{X}_i, \bar{X}_j)}{u(\bar{X}_i)u(\bar{X}_j)} \quad \text{Eq 8-9}$$

where,

$$u(\bar{X}_i) = \sqrt{\sum_{k=1}^n \frac{1}{n^2} u^2(x_k)} = \sqrt{\frac{n}{n^2} u^2(x_k)} = \frac{u(x_k)}{\sqrt{n}} \quad \text{Eq 8-10}$$

And therefore

$$r(\bar{X}_i, \bar{X}_j) = \frac{u(\bar{X}_i, \bar{X}_j)}{u(\bar{X}_i)u(\bar{X}_j)} = \frac{n-|i-j|}{n^2} \frac{u^2(x_h) \sqrt{n} \sqrt{n}}{u^2(x_k)} = \frac{n-|i-j|}{n} \quad \text{Eq 8-11}$$

B.4.4 Deriving the bell-shaped correlation form for a weighted rolling average

A similar consideration can be made where the rolling averaging is a weighted rolling average, then Eq 8-4 is

$$\bar{X} = \sum_{k=i-m}^{i+m} w_k x_k, \quad m = (n-1)/2 \quad \text{Eq 8-12}$$

The partial derivatives are now different, so

$$u(\bar{X}_i, \bar{X}_j) = \sum_h w_{i,h} w_{j,h} u^2(x_h) \quad \text{Eq 8-13}$$

where $w_{i,h}$ is the weight given to x_h in the i average, and $w_{j,h}$ is the weight given to x_h in the j average.

The simplest way to evaluate this expression is to consider that in this case we need to determine the overlap integrals between the two weight functions, where the integral represents and approximation to the sum in Eq 8-13.

B.4.4.1 Overlap integral for two triangles

Consider the example of a weighted rolling average over $n = 2m + 1$ scanlines (i.e. from m scanlines before to m scanlines after each scanline). Consider the case where the weight functions are triangular, so $w_i = (m - |i|) / m^2$. The equation for a triangle centred on X_0 has the equations in Figure 3.

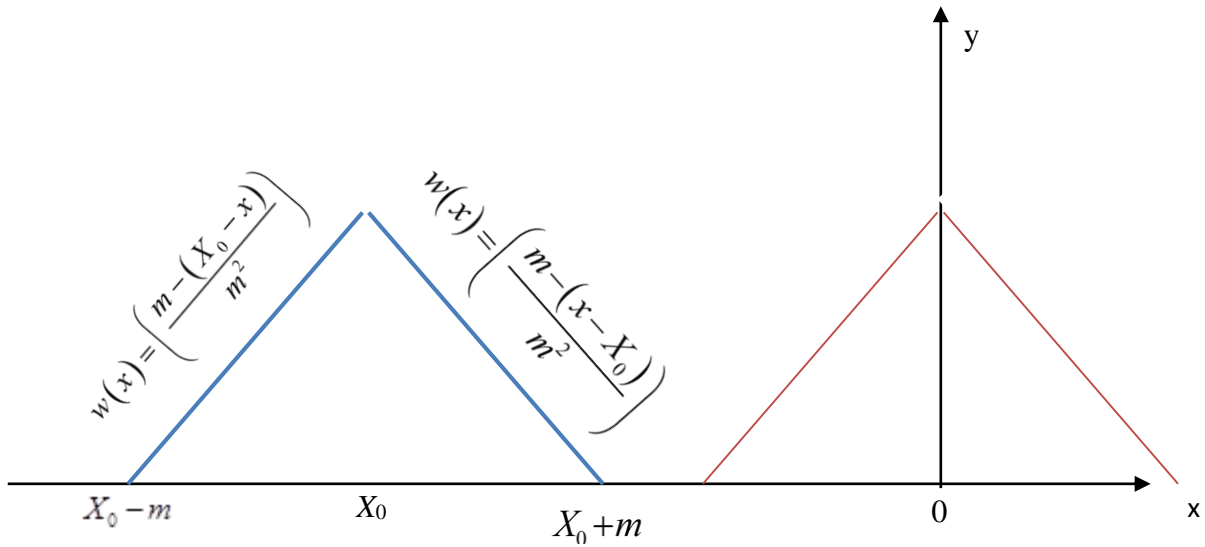

Figure 3 Equation for triangular weights

The overlap integral for two triangles will depend on the extent to which they overlap. There are six conceptual cases, given below.

B.4.4.2 Case 1: No overlap on left

This is the trivial case to the left, as shown in Figure 3. The overlap integral is clearly 0. This occurs for $X_0 < -2m$.

B.4.4.3 Case 2: Small overlap on the left

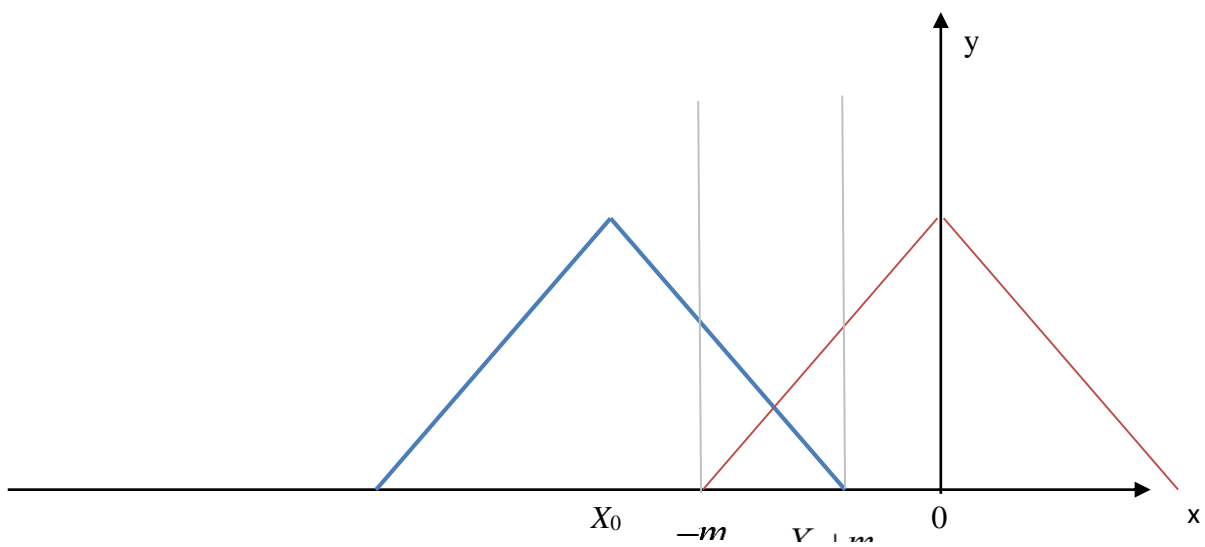

The down slope of one triangle overlaps with the up-slope of the other triangle, when $-2m \leq X_0 < m$.

We calculate the integral $z(X_0)$ as an approximation to the required summation in Eq 8-13.

$$z(X_0) = \frac{1}{m^2} \int_{-m}^{X_0+m} (m-x+X_0)(m+x) dx$$

$$= \frac{(2m+X_0)^3}{6m^2}.$$

Eq 8-14

B.4.4.4 Case 3: large overlap to the left

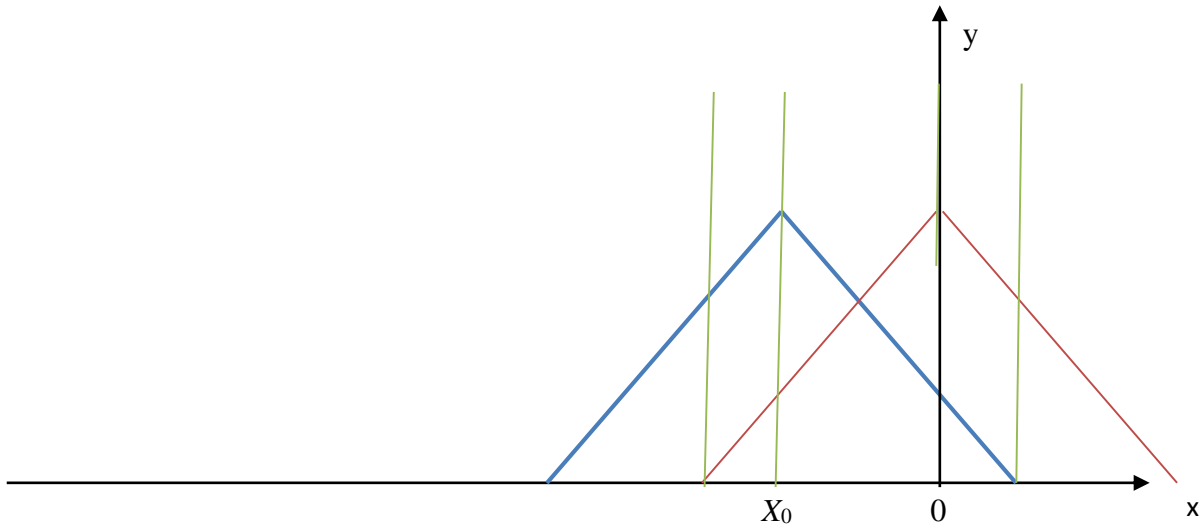

Here there are three zones:

- From $-m$ to X_0 both functions are going up
- From X_0 to 0 one function is going up and one is going down
- From 0 to X_0+m both are going down

The overlap integral is therefore the sum of these three integrals

$$z(X_0) = \frac{1}{m^2} \left[\int_{-m}^{X_0} (m-X_0+x)(m+x) dx + \int_{X_0}^0 (m-x+X_0)(m+x) dx + \int_0^{X_0+m} (m-x+X_0)(m-x) dx \right]$$

$$= \frac{1}{6m^2} \left[(2m-X_0)(m+X_0)^2 - X_0(6m^2+6mX_0+X_0^2) + (2m-X_0)(m+X_0)^2 \right]$$

$$= \frac{1}{6m^2} \left[2(2m-X_0)(m+X_0)^2 - X_0(6m^2+6mX_0+X_0^2) \right].$$

Eq 8-15

B.4.4.5 Cases 4,5 and 6

Case 4 is a large overlap to the right, Case 5 a small overlap to the right and Case 6 is no overlap to the right. These are mirror images of cases 3,2 and 1 respectively.

B.4.4.6 Overlap integral for a triangle

Bringing together all the previous discussion,

$$z(X_0) = \begin{cases} 0, & X_0 < -2m \\ \frac{(2m + X_0)^3}{6m^2}, & -2m \leq X_0 < -m \\ \frac{1}{6m^2} \left[2(2m - X_0)(m + X_0)^2 - X_0(6m^2 + 6mX_0 + X_0^2) \right], & -m \leq X_0 < 0 \\ \frac{1}{6m^2} \left[2(2m + X_0)(m - X_0)^2 + X_0(6m^2 - 6mX_0 + X_0^2) \right], & 0 \leq X_0 < m \\ \frac{(2m - X_0)^3}{6m^2}, & m \leq X_0 < 2m \\ 0, & m \geq 2m \end{cases} \quad \text{Eq 8-16}$$

If this is plotted as a function of X_0 (the distance between the centres of the two rolling averages), we get, for $m = 10$, or $n = 2m + 1 = 21$ (i.e. 21 scanlines are averaged with a weighted average), the overlap integrals shown in Figure 4.

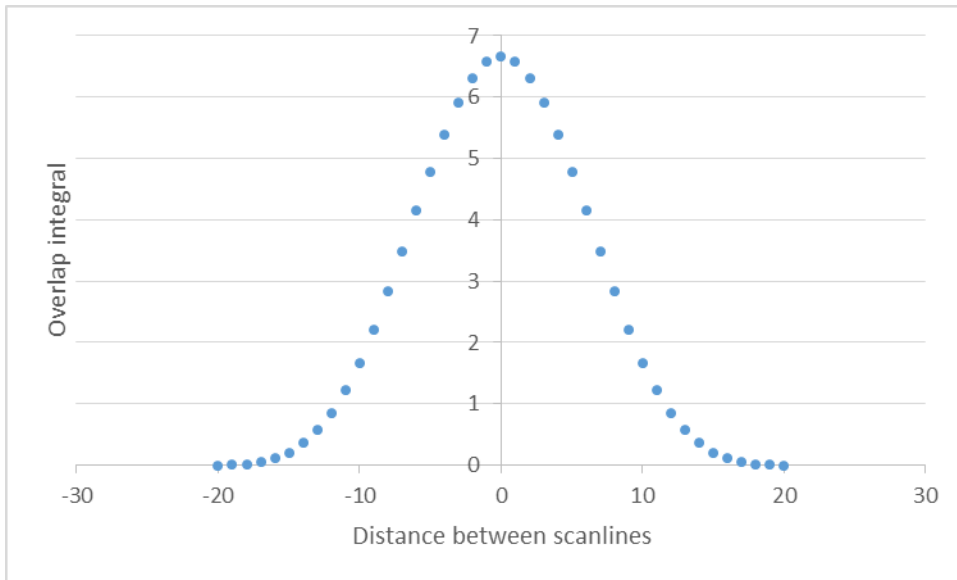

Figure 4 Overlap integral for different scanline separations between rolling averages over 21 scanlines with a triangular weighting function.

This “looks Gaussian”. Intuitively we can understand that if the weights drop off any faster than a triangle, it will look even more Gaussian. For this reason, with any weighted average, we will consider it a bell-shaped correlation form, that is approximated by a truncated Gaussian.

In order to determine the width of the Gaussian that best fits this distribution, we can calculate the variance of the function $z(X_0)$. This is given by calculating

$$\tilde{\sigma}^2 = \frac{\int x^2 z(x) dx}{\int z(x) dx} \quad \text{Eq 8-17}$$

Note, it is important to remember that $z(X_0)$ is not a probability distribution function and this variance is simply an artificial value calculated to fit a shape that is easier to calculate to this function.

The integral $\int z(x)dx$ is the sum of the integral over the six different cases in Eq 8-16. For cases 1 and 6, this is zero. For 2 and 5 it is $\frac{m^2}{24}$ and for 3 and 4 it is $\left(\frac{m^2}{4} + \frac{5m^2}{24}\right)$. Therefore the integral, $\int z(x)dx = m^2$

. Thus

$$\begin{aligned}\tilde{\sigma}^2 &= \frac{\int x^2 z(x) dx}{m^2} = \frac{1}{6m^4} \left[\int_{-2m}^{-m} x^2 (2m+x)^3 dx + \int_{-m}^0 x^2 \left(2(2m-x)(m+x)^2 - x(6m^2 + 6mx + x^2) \right) dx \right. \\ &\quad \left. + \int_0^m x^2 \left(2(2m+x)(m-x)^2 + x(6m^2 - 6mx + x^2) \right) dx + \int_m^{2m} x^2 (2m-x)^3 dx \right] \quad \text{Eq 8-18} \\ &= \frac{1}{6m^4} \left[\frac{11m^6}{30} + \frac{m^6}{6} + \frac{7m^6}{15} + \frac{7m^6}{15} + \frac{m^6}{6} + \frac{11m^6}{30} \right]\end{aligned}$$

And therefore

$$\tilde{\sigma}^2 = \frac{m^2}{3}, \quad \tilde{\sigma} = \frac{m}{\sqrt{3}}. \quad \text{Eq 8-19}$$

In other words, for a weighted rolling average over scanlines, the correlation coefficient between any two scanlines can be calculated as a truncated Gaussian where the truncation (correlation is zero) occurs for lines more than $2m = n - 1$ scanlines apart, and the Gaussian drop off has a width given by Eq 8-19.

B.4.5 Repeating correlation forms

For repeating correlation forms we can write the correlation coefficient by defining the repeated shape and the distance between repeats.

B.4.6 The stepped triangle correlation form

The stepped triangle correlation form represents the situation where there is a calibration window that is additionally smoothed with a rolling average. So, for example, in the HIRS FCDR, the calibration window is within 38 scanlines. If this were the only aspect, then the error correlation form would be “rectangular absolute” and for each scanline we would define the number of scanlines since the start of the calibration window [a] and the number of scanlines to the next calibration window [b] to say that we are fully correlated with other scanlines in the range [-a,b] and have no correlation with scanlines outside that range.

However, to reduce the effect of noise, HIRS has the additional step of creating a rolling average of calibrations from one calibration window to the next. Therefore, between calibration windows there is a triangular correlation form (Appendix B.4.3). This means that the error correlation form between this scanline and other scanlines is a “stepped triangle absolute”.

The stepped triangle absolute correlation form is shown in Figure 5. The correlation form is described for any one scanline by $-a$ and $+b$, representing the number of scanlines before and after, with which it is fully correlated. The rolling average over n calibration windows provides a triangular step. Each step has a width $a+b+1$ scanlines and the covariance between steps is given by Eq 8-8.

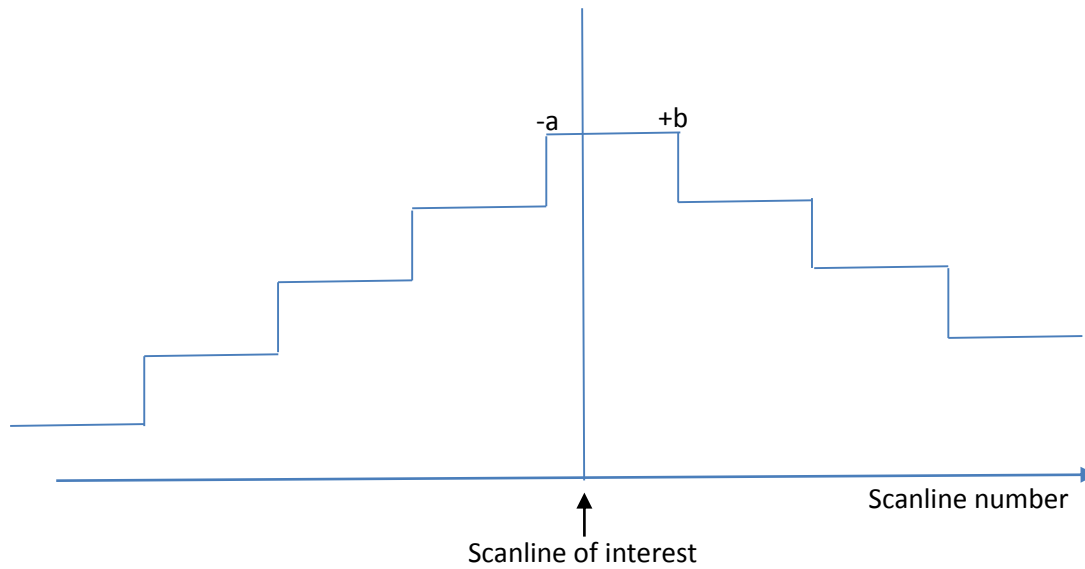

Figure 5 Representation of the stepped-triangle absolute correlation form, defined by $-a, b$ for each pixel and n overall

Thus, for a scanline i , the correlation coefficient to a scanline j is defined by:

- Define k as the number of calibration windows j is away from i .
 - If $i > j$, k is the rounded down integer of $\frac{(i-j-a)}{a+b+1} + 1$.
 - If $i < j$, k is the rounded down integer of $\frac{(j-i-b)}{a+b+1} + 1$.
- If $k \geq n$, then the correlation coefficient is 0
- If $k < n$, then the correlation coefficient is $r(\bar{X}_i, \bar{X}_j) = \frac{n-k}{n^2} u^2(x_h)$. (From Eq 8-8).