

USER'S GUIDE



Vaisala Laser Ceilometer CT25K



PUBLISHED BY

Vaisala Oyj
P.O. Box 26
FIN-00421 Helsinki
Finland

Phone (int.): +358 9 8949 1
Fax: +358 9 8949 2227

Visit our Internet pages at <http://www.vaisala.com/>

© Vaisala 2006

No part of this manual may be reproduced in any form or by any means, electronic or mechanical (including photocopying), nor may its contents be communicated to a third party without prior written permission of the copyright holder.

The contents are subject to change without prior notice.

Please observe that this manual does not create any legally binding obligations for Vaisala towards the customer or end user. All legally binding commitments and agreements are included exclusively in the applicable supply contract or Conditions of Sale.

Table of Contents

CHAPTER 1	
GENERAL INFORMATION	9
About This Manual	9
Contents of This Manual	9
Version Information	10
Related Manuals	11
Safety	11
General Safety Considerations	11
Product Related Safety Precautions	12
Safety Summary	12
Laser Safety	12
ESD Protection	15
Warranty	16
CHAPTER 2	
PRODUCT OVERVIEW	17
Introduction to CT25K Ceilometer	17
Product Nomenclature	19
CHAPTER 3	
INSTALLATION	21
Installation Procedure	21
Unloading and Unpacking Instructions	21
Foundation	22
Assembling the Unit	24
Using the Tilt Feature	27
Cable Connections	28
Grounding	31
Connection of Maintenance Terminal	31
Setting up the Connection	31
Operation	31
Startup	32
Startup Procedure	32
Mobile Operation Aspects	33
Verification of Proper Operation	34
Settings for Normal Operation	35
Factory Settings of User Programmable Parameters	35
CHAPTER 4	
OPERATION	39
Operation Modes	39
Serial Lines. Open and Closed Port	39

User Commands	41
Data Messages	45
Data Message No. 1	46
Data Message No. 2	48
Data Message No. 3	51
Data Message No. 4	52
Data Message No. 5	52
Data Message No. 6	52
Data Message No. 7	54
Status Message "S"	55
Manual Message	58
Polling Mode	58
Prevailing Parameter Settings.....	59
Manual Angle Setting	61

CHAPTER 5

FUNCTIONAL DESCRIPTION	63
Theory of Operation	63
Basic Principle of Operation	63
Practical Measurement Signal.....	63
Noise Cancellation.....	64
Return Signal Strength	65
Height Normalization	65
The Backscatter Coefficient.....	66
Extinction Normalization and Vertical Visibility.....	67
Technical Description	68
General.....	68
LIDAR Measurement.....	70
Internal Monitoring and Control	73
Module Descriptions	74
Optical Subassembly CTB22.....	74
Description.....	75
Laser Transmitter CTT21	76
Description.....	76
Laser Safety	77
Receiver CTR21	77
Optics Monitor CTL21.....	78
Board Frame DMF51	79
Processor Board DMC50B	82
Processor	83
A-to-D Converter	83
Serial Communication Ports.....	83
Technical Information	84
DC Converter DPS52	85
Ceilometer Interface Board DCT52	89
Line and Power Interface Subassembly CTP241	90
Internal Heaters Subassembly CT25039	92
Tilt Angle Sensor CT3675	94
Window Conditioner CT2614 / CT2688.....	96
Maintenance Terminal (Option).....	97
Modem DMX55 (Option).....	98
Modem DMX50 (Option).....	100
Sky Condition Algorithm	102

General.....	102
Option code.....	102
Activation.....	103
Algorithm Overview	103
CHAPTER 6	
MAINTENANCE	107
Periodic Maintenance	107
Alarms and Warnings.....	107
Window Cleaning	108
Battery Check.....	108
Storage.....	109
CHAPTER 7	
TROUBLESHOOTING	111
Normal Operation	111
Equipment.....	111
Instructions	111
Troubleshooting	115
Warnings	116
Alarms	118
Miscellaneous.....	118
Failure Diagnosis	119
CHAPTER 8	
REPAIR	121
General	121
Writing Conventions Used	121
Start-Up Procedure for Replacement (All Parts).....	122
Transmitter CTT21.....	124
Removal	124
Replacement	125
Compensation Adjustments	128
Receiver CTR21	132
Removal	132
Replacement.....	134
Coaxial Cable Replacement.....	136
Removal	136
Replacement	137
Compensation Fiber.....	138
Compensation Fiber Replacement.....	138
Optics Monitor CTL21	139
Removal	139
Replacement	140
Boards of Board Frame DMF51	141
Removing Boards.....	141
Replacing Boards	142
Parameter Settings of Ceilometer Interface Board DCT52.....	142
Line & Power Subassembly CTP241	143
Removal	143

Replacement	144
Internal Heater Subassembly CT25039 Replacement.....	145
Battery 4592 Replacement Instructions	147
Getting Help	148
Return Instructions.....	149

CHAPTER 9

TECHNICAL DATA.....	151
Specifications	151
Mechanical	151
External Connector J1 - Window conditioner	152
External Connector J2 - Power input.....	152
Output Interface.....	152
External Connector J3 - Data line	153
External Connector J4 - Maintenance Line	155
Modem Options	155
Modem Board DMX55.....	155
Modem Board DMX50.....	156
Transmitter	156
Receiver.....	157
Optical System	157
Performance	157
Environmental Conditions.....	157
INDEX	159

List of Figures

Figure 1	CT25K Ceilometer	18
Figure 2	Measurement Unit Handle.....	22
Figure 3	Foundation Construction	23
Figure 4	Mounting the Pedestal.....	25
Figure 5	Attaching the Measurement Unit and the Shield	26
Figure 6	External Connectors (bottom view)	29
Figure 7	Termination Box Wire Connections	30
Figure 8	CT25K Switches and LEDs	33
Figure 9	Operation Modes	39
Figure 10	Open and Closed Port	41
Figure 11	Typical Measurement Signal	64
Figure 12	Measurement Unit Components.....	68
Figure 13	Subassembly Interconnections.....	69
Figure 14	Block Diagram of Operational Units	71
Figure 15	Optical Subassembly CTB22 with Optics Monitor, Transmitter and Receiver Subassemblies	74
Figure 16	CTT21 Block Diagram	76
Figure 17	CTR21 Block Diagram.....	77
Figure 18	CTL21 Block Diagram	78
Figure 19	DMF51 Frame.....	80
Figure 20	DMC50B Block Diagram.....	82
Figure 21	DIP Switch Settings of the DMC50.....	85
Figure 22	DPS52 Block Diagram.....	86
Figure 23	DCT52 Block Diagram.....	89
Figure 24	CTP241 Wiring	91
Figure 25	CT25039 Wiring Diagram	92

Figure 26	CT3675 Tilt Angle Sensor	94
Figure 27	Window Conditioner CT2614 / CT2688	96
Figure 28	DMX55 Block Diagram	98
Figure 29	DMX50 Block Diagram	100
Figure 30	Board Connectors of the DMF51 Board Frame	123
Figure 31	Removing the Laser Transmitter	125
Figure 32	Adjusting the Compensation	129
Figure 33	Compensation Graph	131
Figure 34	Removing the Receiver	133
Figure 35	Removing the Optics Monitor	140
Figure 36	Boards of the DMF51 Board Frame	141
Figure 37	Removing Line and Power Interface Subassembly CTP241 ..	144
Figure 38	Internal Heater Replacement	147
Figure 39	Battery Replacement	148
Figure 40	Data Line Connection Options	154

List of Tables

Table 1	Manual Revisions	10
Table 2	Revision History	10
Table 3	Hardware History	11
Table 4	Related Manuals	11
Table 5	CT25K Ceilometer Main Parts Nomenclature	19
Table 6	Factory Parameter Settings	36
Table 7	User Level Commands	42
Table 8	Advanced Level Commands	44
Table 9	Parts List	69
Table 10	Technical Information	84
Table 11	DIP Switch Settings of the DMC50	85
Table 12	Weight Factors	103
Table 13	Bin Widths	103
Table 14	Minimum Number of Counts (Hits) for Each Layer	104
Table 15	Minimum Distance Between Different Cloud Layers	104
Table 16	Warnings	116
Table 17	Alarms	118
Table 18	Miscellaneous	118
Table 19	CT25K Ceilometr Mechanical Specifications	151
Table 20	Window Conditioner	152
Table 21	Power Input	152
Table 22	Data Line	153
Table 23	Maintenance Line	155
Table 24	Modem Board DMX55	155
Table 25	Modem Board DMX50	156
Table 26	Transmitter	156
Table 27	Receiver	157
Table 28	Optical System	157
Table 29	Performance	157
Table 30	Environmental Conditions	157

This page intentionally left blank.

CHAPTER 1

GENERAL INFORMATION

About This Manual

This manual provides information for installing, operating, and maintaining the CT25K Ceilometer.

Contents of This Manual

This manual consists of the following chapters:

- Chapter 1, General Information, provides important safety, revision history, and warranty information for the product.
- Chapter 2, Product Overview, introduces the CT25K Ceilometer features, advantages, and the product nomenclature.
- Chapter 3, Installation, provides you with information that is intended to help you install this product.
- Chapter 4, Operation, contains information that is needed to operate this product.
- Chapter 5, Functional Description, gives a functional description on the product.
- Chapter 6, Maintenance, provides information that is needed in basic maintenance of the product.
- Chapter 7, Troubleshooting, describes common problems, their probable causes and remedies, and contact information.
- Chapter 8, Repair, explains how to repair the product.

- Chapter 9, Technical Data, provides the technical data of the CT25K Ceilometer.
- INDEX

Version Information

Table 1 Manual Revisions

Manual Code	Description
U059en-1.1	CT25K Ceilometer, User's Guide
M210345en-A	CT25K Ceilometer, User's Guide (this manual)

This manual covers ceilometer CT25K in all its configurations as defined by the parts and options listed in section Chapter 2, Product Overview, on page 17, running under software revision

CT25K- 2.12

Table 2 below lists the revision history that may apply in comparison to other units in use:

Table 2 Revision History

Software Revision	Description
CT25K-1.01	First Release
CT25K-1.02	Intermediate release (not in use)
CT25K-1.03	Intermediate release (not in use)
CT25K-1.04	Production rev. 95-05-15...97-02-03
CT25K-1.04h	Special rev. with Qualimetrics and DR21 messages
CT25K-1.05	Production rev. 97-02-03...
CT25K-2.00	Production rev. 97-11-01...
CT25K-2.01	Production rev. 98-03-17...
CT25K-2.01a	Production rev. 99-02-09...
CT25K-2.02	Special rev. with higher reporting resolution
CT25K-2.02a	Special rev. with higher reporting resolution
CT25K-2.10	Special rev. with Cibus interface
CT25K-2.11	Production rev. 00-08-08
CT25K-2.12	Production rev. 02-09-19

Table 3 on page 11 lists the hardware history that may apply in comparison to other units in use:

Table 3 Hardware History

Hardware History	Description
CT25K model A	First Release
CT25K model B	Enclosure CT1669 replaced with CT15035. Model A pedestal CT2665 (Fiberglass) is option New Metal Pedestal CT25106 is standard. Line and Power Interface Subassembly CTP21 changed to CTP241. Internal Heaters Subassembly CT2690 replaced with CT25039.
CTB22	Replaces CTB21 since 97-05-26
DMC50B	Replaces DMC50A since 97-11-05
DPS52	Replaces DPS51 since 99-03-03
DCT52	Replaces DCT51 since 00-08-08
DMX55	No longer support for Bell 103 since 02-09-25

Related Manuals

Table 4 Related Manuals

Manual Code	Manual Name
U067en	CT-VIEW, User's Guide
M210310en	Termination Box, User's Guide

Safety

General Safety Considerations

Throughout the manual, important safety considerations are highlighted as follows:

WARNING

Warning alerts you to a serious hazard. If you do not read and follow instructions very carefully at this point, there is a risk of injury or even death.

CAUTION

Caution warns you of a potential hazard. If you do not read and follow instructions carefully at this point, the product could be damaged or important data could be lost.

NOTE

Note highlights important information on using the product.

Product Related Safety Precautions

The CT25K Ceilometer delivered to you has been tested for safety and approved as shipped from the factory. Note the following precautions:

WARNING

Ground the product, and verify outdoor installation grounding periodically to minimize shock hazard.

CAUTION

Do not modify the unit. Improper modification can damage the product or lead to malfunction.

Safety Summary

The following safety precautions must be observed during all phases of operation, service, and repair of this instrument.

WARNING

Failure to comply with these precautions or with specific warnings elsewhere in this manual violates safety standards of design, manufacture, and intended use of the instrument. Vaisala Oyj assumes no liability for the customer's failure to comply with these requirements.

Laser Safety

The CT25K is classified as a Class 1M laser device in accordance with International Standard IEC/EN 60 825-1. It is also classified in accordance with U.S. regulation 21 CFR 1040 as a Class 1 laser device. This means that a CT25K Ceilometer installed in a field environment with instrument covers on and pointed vertically or near-vertically poses no established biological hazard to humans.

The device is equipped with the following label:



The instrument is intended for operation in an area restricted from public access, and to be pointed vertically or near-vertically up. The following precautions are to be noted and followed during service and maintenance of the instrument.

WARNING

Never look directly into the Laser Transmitter with magnifying optics (glasses, binoculars, telescopes, etc.).

When operating, avoid looking at the ceilometer unit from the beam direction. When tilting the unit, make sure that it is not being viewed from the beam direction with magnifying optics.

Only trained personnel should perform maintenance functions. Work area access by unauthorized persons during service operations must be prevented.

WARNING

To minimize shock hazard, the instrument chassis and cabinet must be connected to an electrical ground. The instrument is equipped with a three-conductor AC power connector. The power cable must either be plugged into an approved three-contact electrical outlet or the instrument must be carefully earthed to a low-resistance safety ground.

WARNING

Do not operate the instrument in the presence of flammable gases or fumes. Operation of any electrical instrument in such an environment constitutes a definite safety hazard.

WARNING

Do not attempt internal service or adjustment unless another person, capable of rendering first aid and resuscitation, is present.

WARNING

Because of the danger of introducing additional hazards, do not install substitute parts or perform any unauthorized modification to the instrument. Return the instrument to a Vaisala office or authorized Depot for service and repair to ensure that safety features are maintained.

WARNING

Operating personnel must not remove instrument covers. Component replacement and internal adjustments must be made by qualified maintenance personnel. Do not replace components with power cable connected. Under certain conditions, dangerous voltages may exist even with the power cable removed. To avoid injuries, always disconnect power and discharge circuits before touching them.

High voltage will be readily accessible when the transmitter (CTT21) or receiver (CTR21) covers are removed and they are connected to a powered unit. High voltage is present in the Line and Power Interface Subassembly (CTP241), the Internal Heaters subassembly, the Frame (DMF51) Mother Board, and the Window Conditioners at the top of the Shield.

Transmitter (CTT21), Receiver (CTR21), and Line and Power Input Subassembly (CTP241) have the following warning label:

WARNING! HIGH VOLTAGE INSIDE THIS ENCLOSURE

Internal Heaters Subassembly can be hot and has the following warning labels:

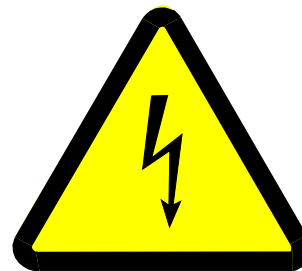

Warnings, such as the example below, precede potentially dangerous procedures throughout this manual. Instructions contained in the warnings must be followed:

WARNING

Dangerous voltages, capable of causing death, are present in this instrument. Use extreme caution when handling, testing, and adjusting.

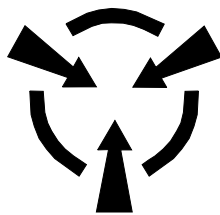
**CAUTION**

The equipment contains parts and assemblies sensitive to damage by Electrostatic Discharge (ESD). Use ESD precautionary procedures when touching, removing or inserting.

ESD Protection

Electrostatic Discharge (ESD) can cause immediate or latent damage to electronic circuits. Vaisala products are adequately protected against ESD for their intended use. However, it is possible to damage the product by delivering electrostatic discharges when touching, removing, or inserting any objects inside the equipment housing.

To make sure you are not delivering high static voltages yourself:

- Handle ESD sensitive components on a properly grounded and protected ESD workbench. When this is not possible, ground yourself to the equipment chassis before touching the boards. Ground yourself with a wrist strap and a resistive connection cord. When neither of the above is possible, touch a conductive part of the equipment chassis with your other hand before touching the boards.
- Always hold the boards by the edges and avoid touching the component contacts.

Warranty

For certain products Vaisala normally gives a limited one year warranty. Please observe that any such warranty may not be valid in case of damage due to normal wear and tear, exceptional operating conditions, negligent handling or installation, or unauthorized modifications. Please see the applicable supply contract or conditions of sale for details of the warranty for each product.

CHAPTER 2

PRODUCT OVERVIEW

This chapter introduces the CT25K Ceilometer features, advantages, and the product nomenclature.

Introduction to CT25K Ceilometer

Ceilometer CT25K measures cloud heights and vertical visibilities. The small and lightweight measurement unit suits well for mobile operation.

The CT25K Ceilometer employs pulsed diode laser LIDAR technology (LIDAR = Light detection and ranging), where short, powerful laser pulses are sent out in a vertical or near-vertical direction. The reflection of light - backscatter - caused by haze, fog, mist, virga, precipitation and clouds is measured as the laser pulses traverse the sky. The resulting backscatter profile, i.e. signal strength versus height, is stored and processed and the cloud bases are detected. Knowing the speed of light, the time delay between the launch of the laser pulse and the detection of the backscatter signal indicates the cloud base height.

The CT25K is able to detect three cloud layers simultaneously. Besides cloud layers it detects whether there is precipitation or other obstructions to vision. No adjustments in the field are needed. The embedded software includes several service and maintenance functions and gives continuous status information from internal monitoring. The software is designed to give the full backscatter profile.

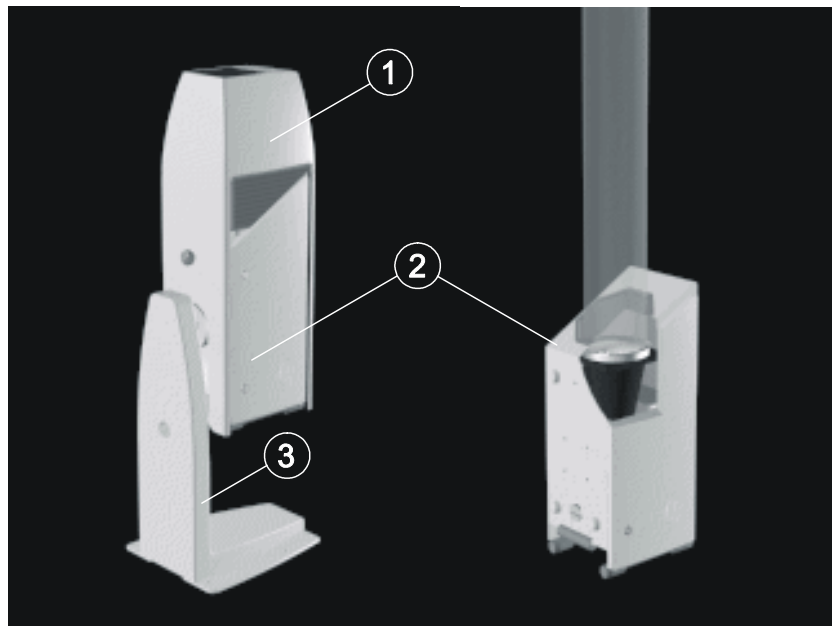

0208-065

Figure 1 **CT25K Ceilometer**

The following numbers refer to Figure 1 above:

- 1 = Shield
- 2 = Measurement Unit
- 3 = Pedestal

Product Nomenclature

Table 5 CT25K Ceilometer Main Parts Nomenclature

Code	Common Name	Description
Measurement Unit:		
CTB22	Optical Subassembly	
CTT21	Laser Transmitter	
CTR21	Receiver	
CTL21	Optics Monitor	
Frame DMF51:		
DMC50B	Processor Board	
DPS52	DC Converter	
DCT52	Ceilometer Interface Board	
DMX55 / DMX50	Modem	Optional
CTP241	Line and Power Interface Subassembly	
	No-break Battery	
CT25039	Internal Heaters Subassembly	
CT3675	Tilt Angle Sensor	
	Internal Cables etc.	
Shield:		
CT2614	Built-in Window Conditioner (warm air blower)	220 ... 240 VAC (option)
CT2688	Built-in Window Conditioner (warm air blower)	100 ... 115 VAC (option)
Pedestal:		
CT25106	Metal Pedestal (standard)	For off-shore applications it is recommended to use fiberglass pedestal CT2665.

The complete delivery also includes mating cables with connectors for power and communication, installation hardware, an Allen key, a triangle key for the Measurement Unit door and this CT25K User's Guide.

In addition, the following options may be included in the delivery:

- Maintenance Terminal (PSION Palmtop computer):
 - Connected to Measurement Unit at the external connector J4 via RS-232 interface.
- Termination Boxes (2) for Line Power CT3709 (external connector J2) and Communication Cable CT3707 (external connector J3) connections.

- Termination box with heavy duty transient protection, for power and signal, Termbox-1200.
- Tropics Window CT35043 on Measurement Unit instead of Standard Window to protect the laser from direct sun radiation.
- Optical Termination Hood CT25184 for indoor service use.
- Shock Absorber CT35022 for ship installations.
- PC Terminal cable CT35198 to connect the connector of the RS-232 port of the PC to the maintenance port
- Bird Collar CT25338 to reduce the disturbing effect of birds sitting on the ceilometer at sites with a large amount of birds.

CHAPTER 3

INSTALLATION

This chapter provides you with information that is intended to help you install this product.

Installation Procedure

Unloading and Unpacking Instructions

The CT25K is shipped in one container containing the Measurement Unit, Shield and Pedestal, and all equipment, accessories and documentation needed for carrying out the installation. Store the original packaging for possible later transport need.

For opening, the package is to be placed on a flat surface with the indicated top side up. The container is opened from the top side and the ceilometer including all other parts are carefully removed.

- Use proper gloves for protection against sharp edges, etc.
- Avoid touching the window or lens surfaces unless cleaning according to instructions.
- Maintain the integral protective caps on the unused external connectors (J3 Data line or J4 Maintenance line).
- Use the measurement unit handle for lifting and carrying. See Figure 2 on page 22.

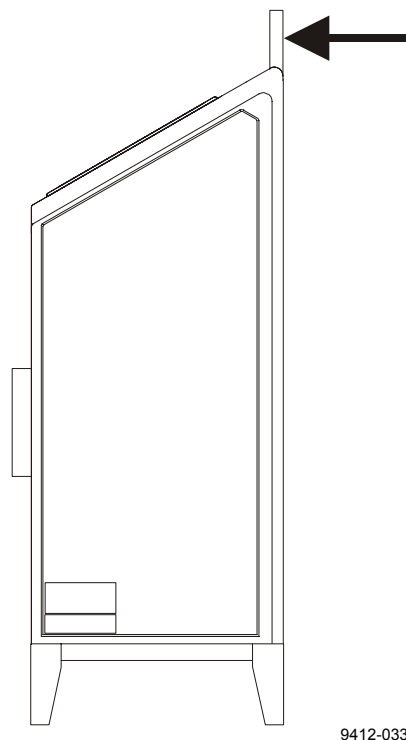
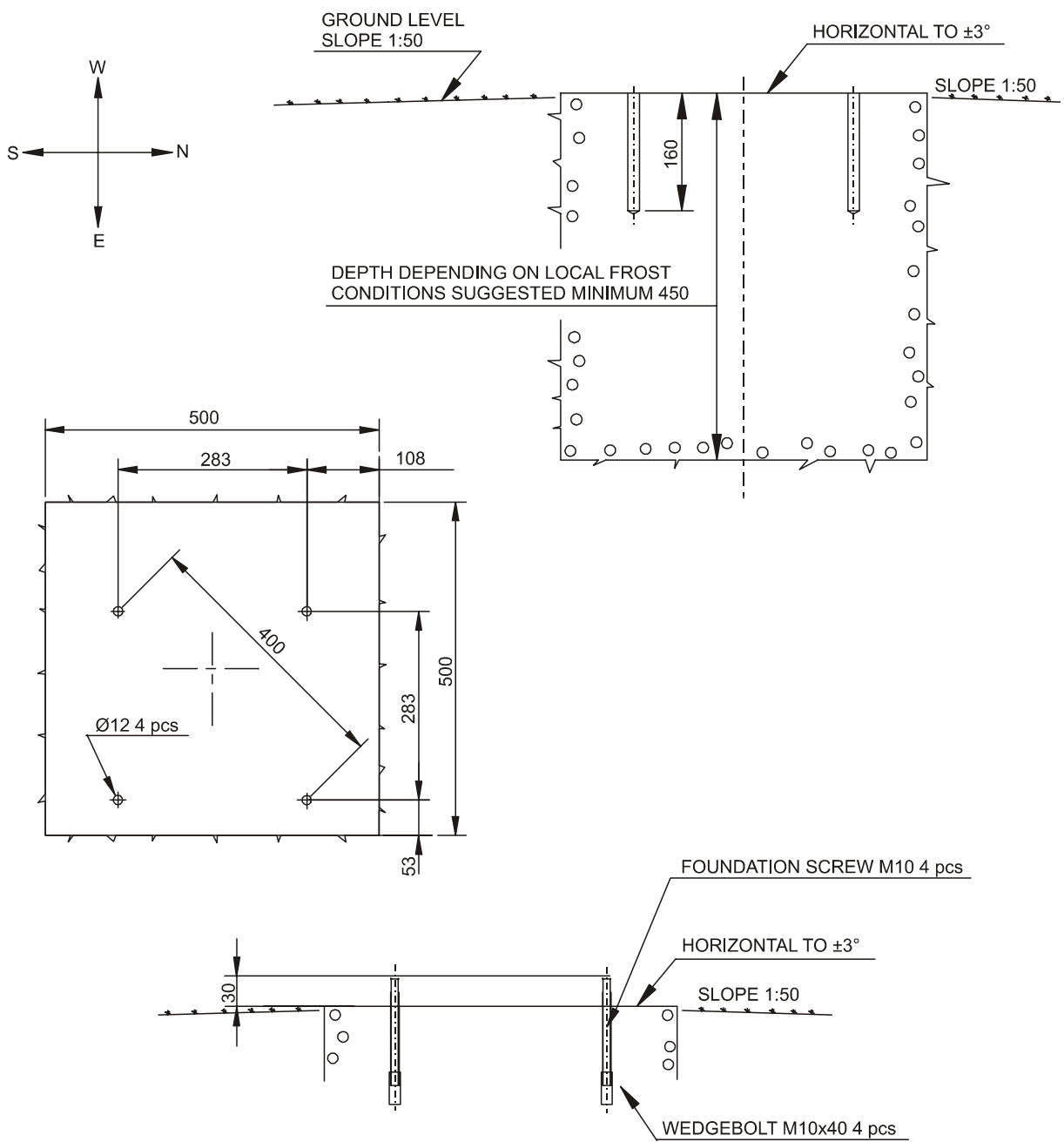

Figure 2 Measurement Unit Handle

If mishandling occurs during transit or installation, the instrument should be returned to a Vaisala office or authorized Depot for inspection.

Foundation

The standard foundation for the CT25K ground installation is a concrete foundation. The minimum dimensions suggested are presented in Figure 3 on page 23. Mounting hardware is included with the delivery.



9412-027

Figure 3 Foundation Construction

There are two alternative ways to make a foundation: to cast a new or to use an existing foundation.

- If a new foundation is laid, the M10x40 Wedge Bolts and Foundation Screws (4 each), are suggested to be cast into the concrete so that approx. 30 mm (1.25 in.) of the foundation screw threads stand above the surface.

- If an existing foundation is used, four holes of diameter 12 mm and depth 165 mm (0.5 x 6.5 in.) are drilled into the concrete. The Wedge Bolt and Foundation Screw combinations are placed in the holes, with Wedge Bolts down; the protruding threads are alternately hammered and tightened a few times so that the Wedge Bolts attach to the hole walls.

In case the CT25K replaces a CT12K Ceilometer, the existing foundation and screws can be used.

If the tilt feature will be used (see section Using the Tilt Feature on page 27), observe this in the layout of the foundation screws and pedestal placement.

Assembling the Unit

The CT25K Ceilometer is assembled in four stages:

Mount the pedestal on the foundation.

Attach the measurement unit to the pedestal.

Mount the shield on the measurement unit.

Connect the external cables.

1. Place the Pedestal on the foundation (or equivalent installation place) so that the vertical leg of the pedestal faces East in the Northern hemisphere, and West in the Southern hemisphere.

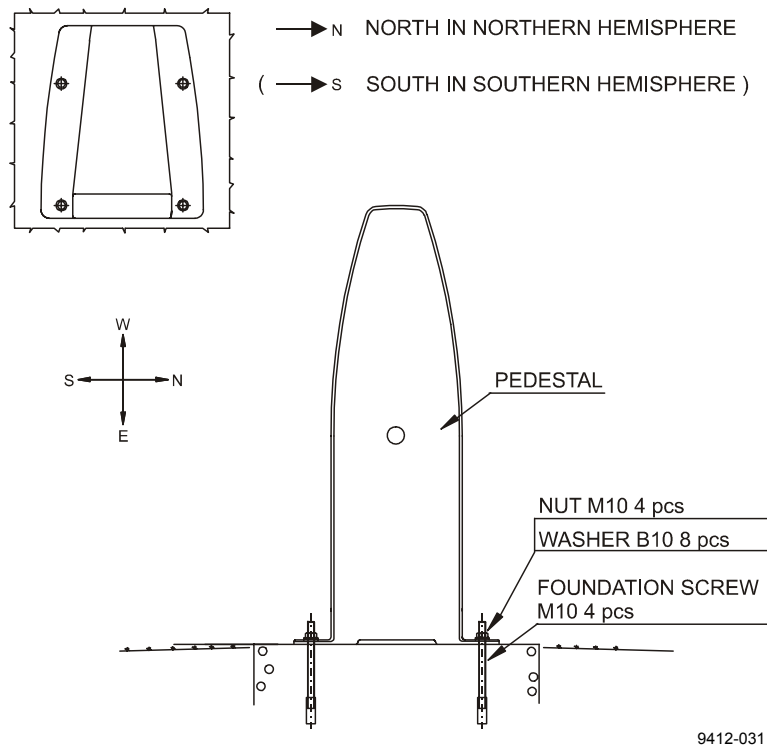
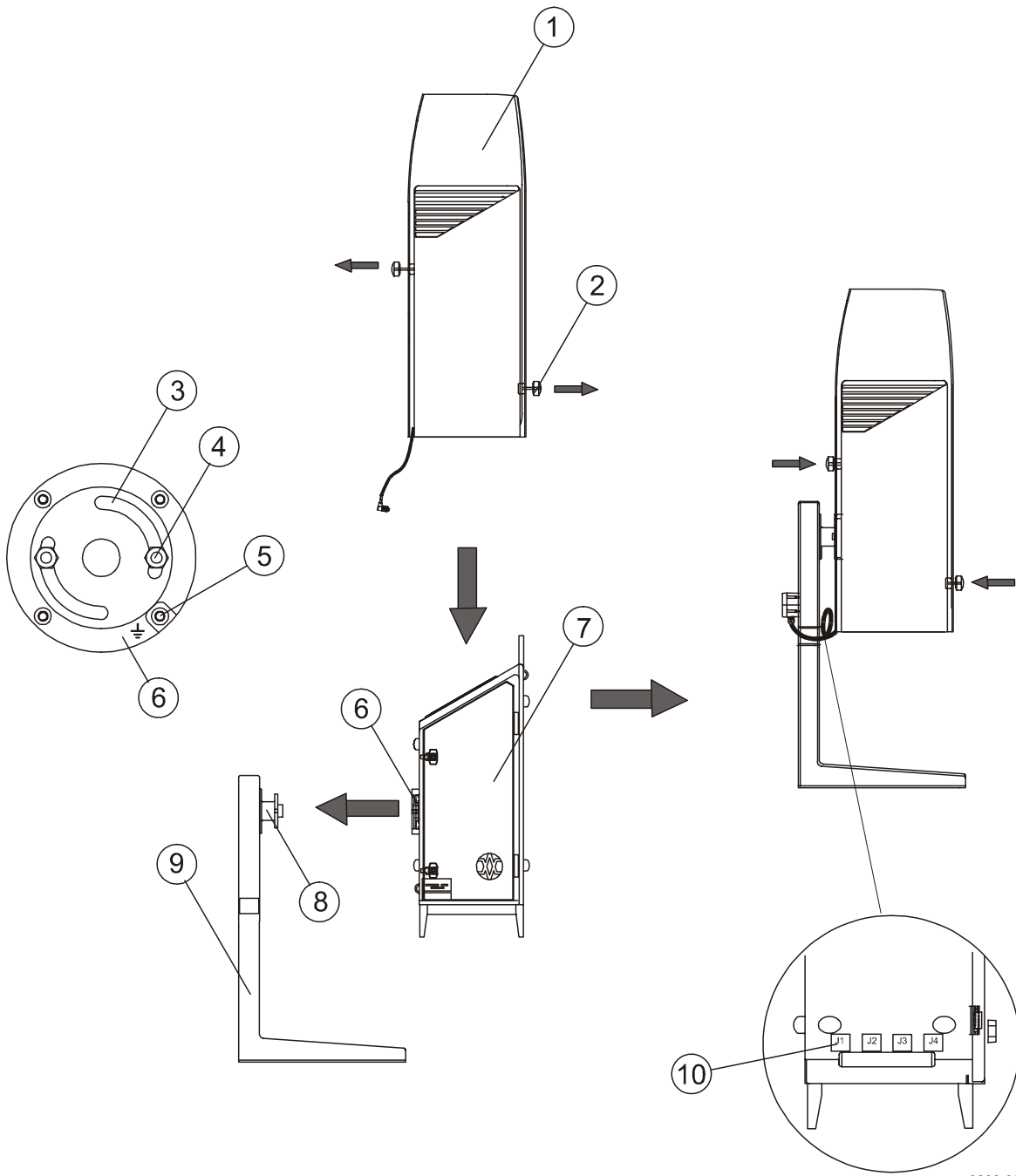

Figure 4 Mounting the Pedestal

If the tilt feature will be used (see section Using the Tilt Feature on page 27), observe this in the layout of the foundation screws and pedestal placement. Place the flat washers on the foundation screws and fix the nuts (see Figure 4 above).

2. Start mounting the measurement unit by rotating the friction ring of the flange to the position shown in Figure 5 on page 26 (the screw holes horizontally). Remove the Allen head screws (2 pcs) and flat washers. Place the measurement unit on the pedestal flange. Attach the pedestal flange to the measurement unit by the two Allen head screws with flat washers. An Allen key is included in the delivery.



0208-066

Figure 5 Attaching the Measurement Unit and the Shield

The following numbers refer to Figure 5 on page 26:

- 1 = Shield
- 2 = Knob
- 3 = Friction ring
- 4 = Flat washer
- 5 = Earth connection
- 6 = Flange (on measurement unit)
- 7 = Measurement unit
- 8 = Pedestal flange
- 9 = Pedestal
- 10 = External connector J1

3. Before placing the shield pull the knobs (pidgeon blue) on the shield outwards. Place the shield carefully on the Measurement Unit; be careful with the Window Conditioner cable. Tighten the two attachment knobs (see Figure 5 on page 26). Before connecting the Window Conditioner cable check that the voltage rating of the Window Conditioner (written at its connector) is correct. Connect the Window Conditioner cable plug of the shield to the measurement unit external connector J1.
4. Connect external cables according to section Cable Connections on page 28.

Using the Tilt Feature

The Measurement Unit and Pedestal of Ceilometer CT25K are designed so that the unit can operate in a tilted direction. The built-in tilt angle sensor CT3675 detects the tilt angle, i.e. deviation from the vertical. The tilt angle ranges from -15 to +90 degrees from vertical; the angle is positive when the measurement unit door turns towards the ground. The cosine of the tilt angle is used for automatic correction of the detected cloud base height, which enables accurate cloud base measurements also in a tilted direction.

Several advantages can be realized with the aid of this feature:

- Heavy weather conditions
 - Using a slight tilt angle for instance 15 degrees, the measurement unit window is kept better protected from precipitation, thus enhancing the performance in heavy weather conditions.
- Aircraft approaches

- The beam can be directed towards a direction, which better represents the approach of an aircraft than the straight vertical. Useful e.g. for helicopter approaches, and sites where the ceilometer cannot be located exactly at the desired spot.
- Hard target and testing purposes
 - Tilting the unit down by 90 degrees permits verification of operation against a hard target at a known distance. Useful in connection with installation and maintenance. Enables real backscatter signal detection when there are no clouds in the sky.

WARNING

Make sure that nobody is viewing the unit from the beam direction with magnifying optics.

- Maintenance
 - By tilting the unit back -15 degrees, better access is gained to the interior during maintenance.
- In the tropics
 - Between the latitudes of ± 25 degrees, where the sun can be straight above the unit, a slight tilting prevents the laser from direct sun radiation, which would otherwise destroy the laser. The other alternative is to use a tropics window on the measurement unit instead of a standard window.

As these advantages are partly contradictory and cannot or need not all be realized, the user must decide the final installation direction. In doing so, the following must be observed:

NOTE

Unless a tropics window is used, the unit must never be directed so that the sun shines directly into the optics, because the lens will focus all radiation into a very hot spot.

Cable Connections

All external connectors to the Measurement Unit are located at the bottom left edge as seen from the door direction. Figure 6 on page 29 shows the external connectors J1, J2, J3 and J4.

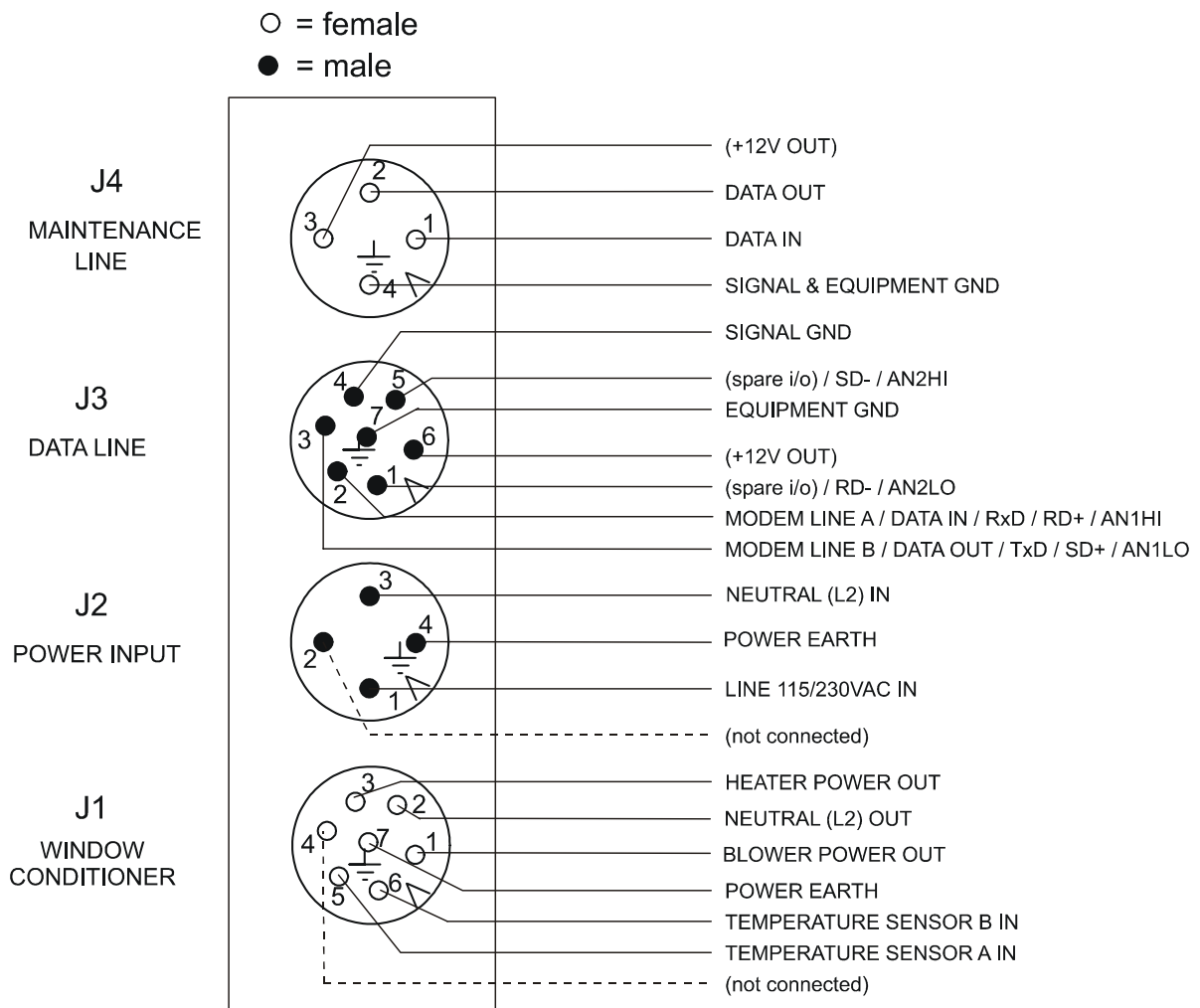

9807-046

Figure 6 External Connectors (bottom view)

- The Window Conditioner (warm air blower) mounted in the Shield is connected to J1.
- Line Power input is connected to J2.
- Remote communication is normally connected to J3.
- A local maintenance terminal, for example a laptop or a palmtop, is intended to be connected to J4. A protective cap is included for covering J4 when not in use.

External mating connectors with 2 m (7 ft.) cable are included for J2 and for J3. The power plug of the J2 cable can be cut when the unit is permanently installed at the final site.

The cables for J2 and J3 are intended to be drawn through the hole of the pedestal to the connectors. Provide sufficient slack for permitting the unit to be tilted later.

NOTE

Before connecting power check the voltage setting of the CTP241 Line and Power Interface (voltage setting shown between the switches F1 and F2, see Figure 8 on page 33).

Figure 7 below shows the connecting signal leads with optional Power and Signal Termination Boxes.

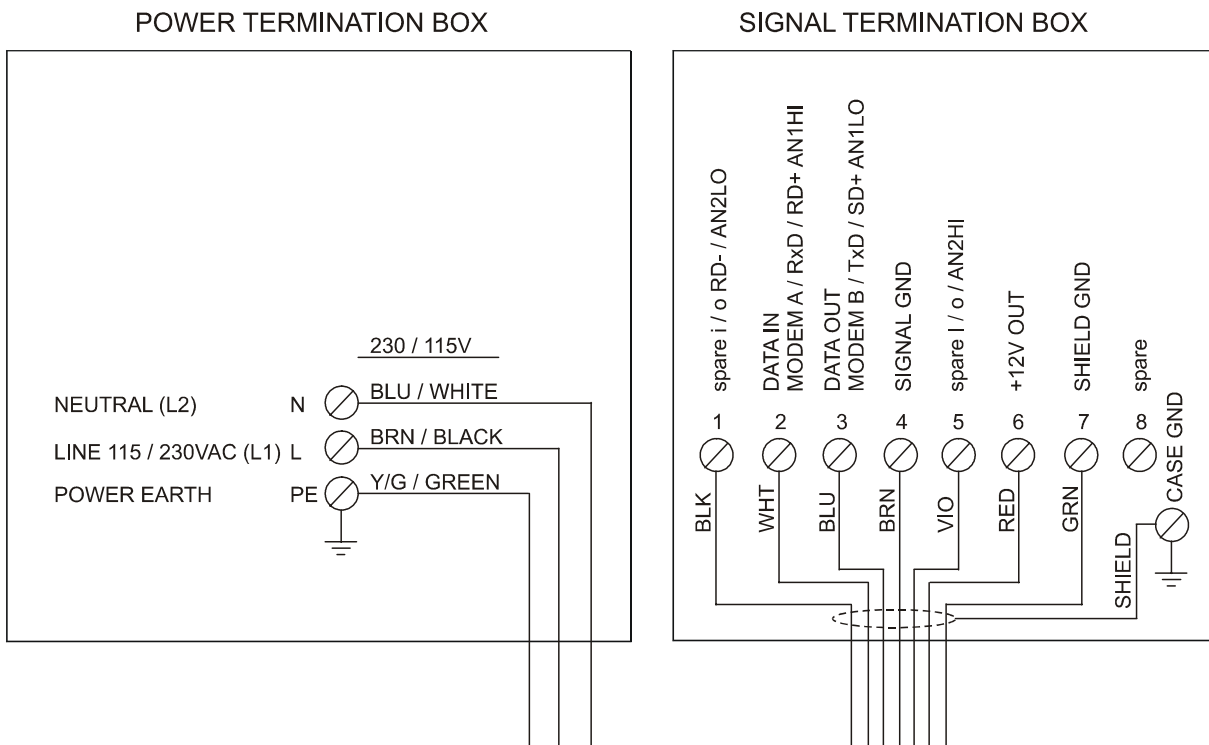

9412-037

Figure 7 Termination Box Wire Connections

Suggested wire dimensions for the external cabling are:

- Line Power Supply: 3 x 1.5 mm² (AWG 16)
- Remote Communication: Remote Communication:

NOTE

When permanent line power installation is made, the maximum size of the fuse protecting the power line is 10 A.

Grounding

The power supply connector J2 provides a standard protective ground for the instrument chassis.

The CT25K is equipped with a separate grounding screw on the measurement unit flange for external earthing (see Figure 5 on page 26).

Connection to a solid earth ground at the installation site is mandatory for adequate lightning and transient protection.

Connection of Maintenance Terminal

Any terminal or PC with serial interface and terminal emulation program can be used for operation and maintenance of the CT25K Ceilometer. A standard Maintenance Terminal option is offered including the following components:

- PSION Palmtop Computer
- RS-232 cable (CT35198)
- Technical Manuals for the Palmtop Computer

Setting up the Connection

1. Connect the RS cable to the ceilometer maintenance port (connector J4) and the terminal computer.
2. Set the following settings for the terminal:

Baud rate	2400
Data bits	7
Stop bits	1
Parity	Even
Handshake	None

Operation

Turn CT25K power on. Press ENTER. The prompt 'CT:' should appear on the screen. If not, check the cables and port settings.

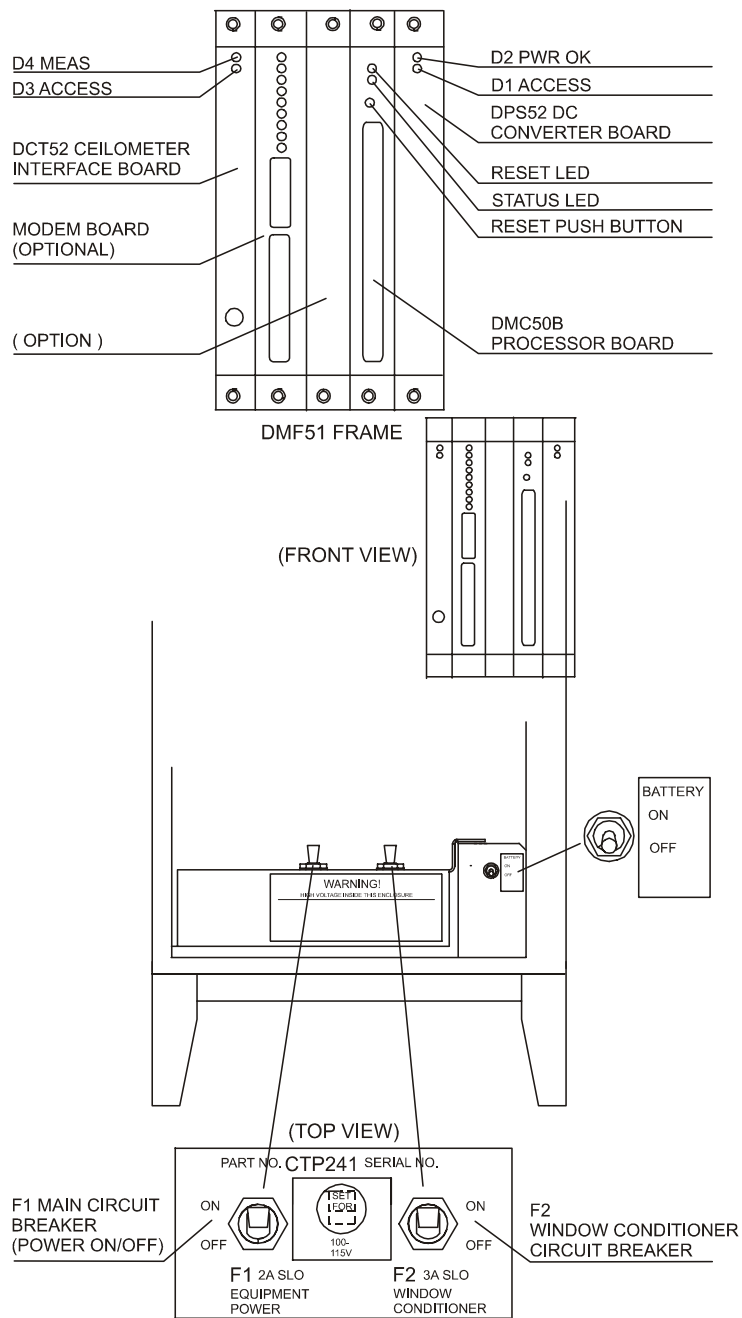

9412-036

Figure 8 CT25K Switches and LEDs

Mobile Operation Aspects

The small and lightweight CT25K Ceilometer is suitable also for mobile operation. It has a built-in 12V battery, which enables

operation without external power supply for about an hour in normal room temperature.

NOTE

For switching power to the CT25K fully OFF, turn also the Battery Switch OFF in addition to the line power switch. Having the unit ON with battery supply only will drain the battery.

NOTE

Do not attempt to carry a fully assembled unit alone. Lift the CT25K from Measurement Unit Base or Pedestal only (not from the shield). The three main parts - Measurement Unit, Shield and Pedestal - can be lifted and carried separately by one person.

Verification of Proper Operation

Proper operation of the Ceilometer can be checked with help of the maintenance terminal. Turn the power on. After 30-45 seconds ask for the status message with the command GET STATUS. Information about commands can be found in chapter 4 Operation. The message should not contain any warnings or alarms. In the opposite case see Chapter 7, Troubleshooting, on page 111.

If a solid, stable cloud base is present at a range of 1,000-5,000 ft., and no fog or precipitation is present, a quick-check of the detection and the unit sensitivity can be carried out by observing the variable SUM on the third line of data message No.2. SUM indicates the sum of detected and normalized backscatter and its value should be in the range 150...200 if parameter SCALE has the standard value 100 %. See section Data Message No. 2 on page 48 for details.

If suitable clouds are not present for proper operation verification, the unit may be tilted towards a hard target at known distance. The minimum distance to the hard target should be at least 300 meters (1,000 ft.). Unexpected behavior is not totally excluded if e.g. a strong reflector saturates the receiver.

WARNING

When tilting the unit, make sure that nobody is watching it with binoculars or other magnifying optics.

Settings for Normal Operation

Switch settings for normal operation are as follows:

Main circuit breaker F1	ON
Window conditioner circuit breaker	ON
Battery switch	ON

Data message and interface configuration and the configuration of measuring interval and transmission speed are standard factory settings. When required, the settings can be changed by giving commands with the terminal.

During the factory alignment procedure, the optical adjustments are carefully carried out to fulfill the requirements and specifications of the device. Optical adjustments have been made at factory or depot, thus there is no need to readjust in the field.

Factory Settings of User Programmable Parameters

Table 6 on page 36 shows the standard factory settings of user programmable parameters. The prevailing parameter settings can be seen by the command:

GET parameter_group

Parameter groups are displayed as bold text in Table 6 on page 36. As response to the command a list of parameters with prevailing parameter values is shown.

The standard factory-set parameter values, which may be changed by the user, are collected in the second column in Table 6 on page 36. The values displayed in the first column are factory settings that the user cannot change. For changing a value to the desired content and function, depending on the particular installation, the corresponding command is:

SET parameter_group parameter

Table 6 Factory Parameter Settings

Response to User's Menu Commands...	Standard Factory Settings of User's Menu Parameters	Notes
CEILO>get...		
...data acq		
AUTOADJUSTMENTS:	ON	
DATA-ACQ. INTERVAL:	15 SEC.	15... 120 seconds available.
RECEIVER		
GAIN:	H	
BANDWIDTH:	N	
SAMPLING RATE:	10 MHz	Constant
TRANSMITTER		
LENGTH OF PULSE:	L	
POWER OF PULSE:	188	Varies with unit, temperature, and age.
QUANTITY OF PULSES:	64K	Constant
COMPENSATION		
COARSE COMPENSATION:	13	Varies with unit and contamination.
FINE COMPENSATION:	125	Varies with unit and contamination.
...message		
MESSAGE		
ANGLE CORRECTION:	ON	Shall be ON if unit is operated tilted. May be ON even if unit is operated vertical. Option OFF will turn detected values into distances rather than heights.
HEIGHT OFFSET:	0	Insert installation height if significantly different from reference (zero) height, in reporting units.
MODE:	AUTOSEND	Option POLLING. Transmits date message only when polled.
NOISE H2 COMPENSATION:	OFF	Option: ON. Affects the visual appearance of message No. 2 graphical presentation. Selection OFF gives less noisy appearance.
PROFILE SCALE:	100 %	Scales backscatter values of message No. 2 and corresponding SUM value.
PORT:	DATA	Optional selection: MAINTENANCE.
TYPE:	MSG1	Message No. 1. Options: MSG2, MSG3, MSG6, MSG7 and Status (S).
UNITS:	FEET	Option: METERS. Note also HEIGHT OFFSET.

Response to User's Menu Commands...	Standard Factory Settings of User's Menu Parameters	Notes
WARNING DELAY:	OFF	Option ON. Sets a 5 minutes delay for warning.
...oper_mode		
OPERATION MODE:	CONTINUOUS	Option STANDBY requires command START for carrying out each cycle.
...options		
[MODEM NAME]	INSTALLED	Modem name is: DMX55 or DMX50
SKY CONDITION:	INACTIVE	ACTIVE
HUMITTER:	INACTIVE	ACTIVE
BLOWER:	ACTIVE	INACTIVE
... port		
MAINTENANCE PORT BAUDS:	2400, E71	Optional baud rates 300, 2400, 4800, 9600.
DATA PORT BAUDS:	300, E71	Optional baud rates 300, 1200, 2400, 4800, 9600. NOTE: Reverts to 300 if standard modem DMX55 is plugged in. 2400 is factory setting if this modem is not present.
MODEM:	CCITT (300) DMX50 V42 BIS MODE (1200-9600)	If modem DMX55 installed. Options: ITU-T V.21 and V23 4-wire. If modem DMX50 is installed. Options: Bell 103, Bell 212A, ITU-T V.21, ITU-T V.22, V42 MODE, V42 BIS MODE
MODEM STATUS:	ON	OFF
YOU ARE USING:	DATA PORT	Option: MAINTENANCE PORT
...unit_id		
UNIT ID:	0	Insert 1 ... 9, A ... Z if polling or message logging from several units requires separating identifiers.

This page intentionally left blank.

CHAPTER 4

OPERATION

This chapter contains information that is needed to operate this product.

Operation Modes

There are two operation modes, continuous i.e. normal and standby. Commands OPER_MODE STANDBY and OPER_MODE CONTINUOUS are used to switch between the modes. In NORMAL mode continuous measurement and message transmission occurs according to chosen parameters. In STANDBY mode the wearing parts are turned off and it can be used e.g. during periods when measurement is not needed. It allows single-cycle measurement by command START.

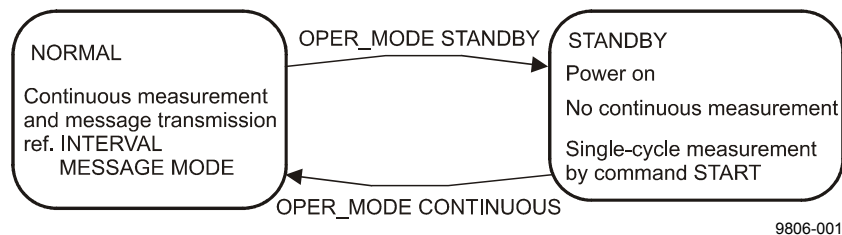

Figure 9 Operation Modes

Serial Lines. Open and Closed Port

Two serial lines are provided, termed "MAINTENANCE" (external connector J4, Line/Port A at Processor Board) and "DATA" (external connector J3, Line/Port B at Processor Board). Line B is intended to be used for measurement data communication and can be operated through modem or baseband. Line A is intended for on-site

maintenance access, and is used only baseband. However, functionally the operation of the lines is identical; the same commands, operations and messages operate through any of the lines, and the following description applies to both of them.

Factory default setting is 7 data bits, Even parity, 1 Stop bit, and for baseband lines, 2400 baud. Baud rate is selectable in the user menu.

7-bit USASCII character format is used. Letter case UPPER/lower can both be used; response will use the upper case.

Standard operation of the serial lines requires no handshake signals.

A communication port, i.e. serial line, has two internal states (Figure 10 on page 41).

CLOSED Measurement data message transmitting state. In this state messages are transmitted automatically at predetermined intervals, or as a response to a polling input string, depending on the corresponding settings. User commands are not accepted, except command OPEN, which turns the line into the OPEN state. No input is echoed but ENTER inputs are responded to by character string CT:

OPEN User dialog state. In this state the user commands are responded to. Command input is echoed. A command prompt CEILO> is displayed as an indication of readiness for command input from the user. Command line termination and command execution is by key and character ENTER = RETURN = CARRIAGE RETURN. No automatic measurement data message transmission is executed in the OPEN state. The port reverts into the CLOSED state by command CLOSE. Automatic 2-minute time-out after last character input is applied. A 2 ... 60-minute time-out may be set by command SET PORT TIME_OUT.

NOTE

Only one of the ports can be OPEN for commands at a time. Only one of the ports transmits measurement messages at a time. Additionally, in RS-485 mode a unit ID must be given with the command OPEN.

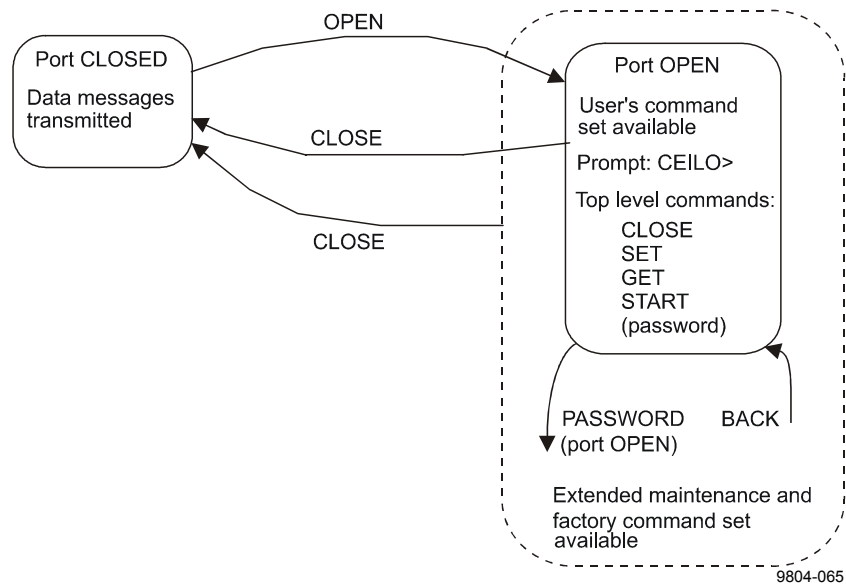

Figure 10 Open and Closed Port

User Commands

User commands, command hierarchy and description are described in Table 7 on page 42. User commands are accessible after opening the line by command OPEN (no password needed).

The command line interpreter provides interactive help support, so that the exact format of commands doesn't have to be remembered. At each level of the menu, keying ENTER first provides an output of the menu available, the second ENTER provides an eventual HELP text. Keying in a letter followed by ENTER outputs all commands with the same first letter; keying in two letters followed by ENTER outputs all commands with the same first two letters, etc.; when only the one desired command is left, then it is executed when ENTERed. This way one needs to know only approximately what one wants to do, and the system provides the necessary aid.

In addition to the user's menu and command set there is a second in-depth maintenance and service level menu and command set, which is intended for more profound system changes and diagnostics. Password for this level is "advanced". Commands on this level should be used only according to instructions described in this manual.

Table 7 User Level Commands

Command	Description
CLOSE	Release port for message transmission, i.e. abort command dialog
SET CONTROL BLOWER ON	Turn window conditioner blower on
SET CONTROL BLOWER OFF	Turn window conditioner blower off
SET CONTROL BLOWER MANUAL	Set window conditioner blower to manual control
SET CONTROL BLOWER AUTO	Set window conditioner blower to automatic control
SET CONTROL INHEATER ON	Turn internal heater on
SET CONTROL INHEATER OFF	Turn internal heater off
SET CONTROL OUTHEATER ON	Turn window conditioner heater on
SET CONTROL OUTHEATER OFF	Turn window conditioner heater off
SET DATA_ACQ INTERVAL 15...120	Set interval for measurement and message sending
SET MESSAGE ANGLE_COR ON	Cloud and vertical visibility heights (distances) in messages ARE corrected for the tilt angle.
SET MESSAGE ANGLE_COR OFF	Cloud and vertical visibility heights (distances) in messages are NOT corrected for the tilt angle.
SET MESSAGE HGTH_OFFSET -1000 ... 1000 (ft) or -304 ... 304 (m)	Height offset: Cloud and vertical visibility values are corrected by this offset value. Positive values add to, negative values subtract from measured height. Unit is m or ft as set by UNITS command.
SET MESSAGE MODE AUTOSEND	Measurement messages are transmitted automatically set by command INTERVAL.
SET MESSAGE MODE POLLING	Measurement messages are transmitted according given polling string.
SET MESSAGE PORT DATA	Message is directed to the Data port (default), non-volatile.
SET MESSAGE PORT MAINTENANCE	Message is directed to the Maintenance port, non-volatile.
SET MESSAGE PROFILE SCALE 0 ... 999	Factor for scaling the range gate data items of Message No. 2. Normal value: 100 (%).
SET MESSAGE PROFILE NOISE_H2 OFF	Range gates data is range normalized only if backscatter is contained.
SET MESSAGE PROFILE NOISE_H2 ON	Range gates data is always range normalized, even noise.
SET MESSAGE TYPE MSG1	Message No. 1 is transmitted.
SET MESSAGE TYPE MSG2	Message No. 2 is transmitted.
SET MESSAGE TYPE MSG3	Message No. 3 is transmitted.
SET MESSAGE TYPE MSG6	Message No. 6 is transmitted.
SET MESSAGE TYPE MSG7	Message No. 7 is transmitted.
SET MESSAGE TYPE STATUS	Status message is transmitted.
SET MESSAGE UNITS FEET	Reported heights unit is feet.
SET MESSAGE UNITS METERS	Reported heights unit is meters.
SET MESSAGE WARN_DELAY OFF	Warning character W is set in message immediately.
SET MESSAGE WARN_DELAY ON	Warning character W is set in message after 5 minutes delay.
SET OPER_MODE CONTINUOUS	Operation mode: Continuous measurement mode.
SET OPER_MODE STANDBY	Standby mode, no measurement unless commanded by START (initiates one cycle).
SET PORT TIMEOUT 2 ... 60	Timeout for automatic CLOSE of dialog mode. Value is minutes. Default: 2 minutes.
SET PORT MAINTENANCE BAUD B300	Set maintenance port bit rate to 300 bits/s.
SET PORT MAINTENANCE BAUD B2400	Set maintenance port bit rate to 2400 bits/s.

Command	Description
SET PORT MAINTENANCE BAUD B4800	Set maintenance port bit rate to 4800 bits/s.
SET PORT MAINTENANCE BAUD B9600	Set maintenance port bit rate to 9600 bits/s.
SET PORT DATA MODEM BELL_103	300 bits/s modem mode. Note! Requires DMX50 modem.
SET PORT DATA MODEM V21	300 bits/s modem mode.
SET PORT DATA MODEM BELL_212A	1200 bits/s modem mode.
SET PORT DATA MODEM V22	1200 bits/s modem mode.
SET PORT DATA MODEM V23_FDX	1200 bits/s, 4-wire full duplex. Note! Requires hardware configuration.
SET PORT DATA MODEM V42_NORMAL	1200 ... 2400 bits/s modem mode, with error correction (V.22bis+V.42bis).
SET PORT DATA MODEM V42_BIS	1200 ... 9600 bits/s modem mode, with error correction and data compression (V.22bis+V.42bis).
SET PORT DATA INTERFACE RS232	Use RS-232 serial line.
SET PORT DATA INTERFACE RS422	Use RS-422 4-wire serial line.
SET PORT DATA INTERFACE RS485_2W	Use RS-485 2-wire serial line.
SET PORT DATA INTERFACE RS485_4W	Use RS-485 4-wire serial line.
SET PORT DATA BAUD B300	Set data port serial line baud rate to 300.
SET PORT DATA BAUD B1200	Set data port serial line baud rate to 1200.
SET PORT DATA BAUD B2400	Set data port serial line baud rate to 2400.
SET PORT DATA BAUD B4800	Set data port serial line baud rate to 4800.
SET PORT DATA BAUD B9600	Set data port serial line baud rate to 9600.
SET UNIT_ID 0 ... Z	Unit identifier: Alphanumerical character for message and polling identification.
GET ALGORITHM	Print values of algorithm parameters.
GET DATA_ACQ	Print settings of data acquisition.
GET FACTORY	Print values of factory settings.
GET INFO	Print identifying information for this equipment configuration.
GET MESSAGE	Print message setting.
GET OPER_MODE	Print operating mode.
GET OPTIONS	Print installed modem and active options.
GET PORT	Print values of port setting.
GET STATUS	Print STATUS message.
GET UNIT_ID	Print unit identification string.
GET VALUE OTHERS ANGLE	Print value of tilt angle sensor, range -15 ... +90 degrees from vertical.
GET VALUE OTHERS POWER_OF_P	Print measured value of laser pulse power, units: mV at A-to-D converter input.
GET VALUE OTHERS RADIANCE	Print measured value of background radiance, units: mV at A-to-D converter input.
GET VALUE OTHERS WINDOW	Print measured value of window contamination monitor, units: mV at A-to-D converter input.
GET VALUE TEMPERATURE BLOWER	Print value of measured blower temperature, units: ° C.
GET VALUE TEMPERATURE CPU	Print value of measured CPU board temperature, units: ° C.
GET VALUE TEMPERATURE LASER	Print value of measured laser temperature, units: ° C.
GET VALUE TEMPERATURE LENS	Print value of measured temperature adjacent to lens, units: ° C.
GET VALUE TEMPERATURE OUTSIDE	Print value of measured outside temperature, units: ° C.

Command	Description
GET VALUE VOLTAGE BCIRCUIT	Print status of battery circuit, connected / disconnected = 1 / 0.
GET VALUE VOLTAGE BATTERY	Print value of battery voltage, approx. +13 V.
GET VALUE VOLTAGE CHARGE	Print value of battery charge voltage, approx. +13 V.
GET VALUE VOLTAGE VCA	Print value of internal raw voltage, approx. +25 V.
GET VALUE VOLTAGE PHV	Print receiver high voltage, approx. +25 V.
GET VALUE VOLTAGE PFB	Print value of receiver switcher internal feedback voltage, approx. +2 V.
GET VALUE VOLTAGE P65	Print value of transmitter high voltage, approx. +65 V.
GET VALUE VOLTAGE P18	Print value of general internal supply voltage +18 V.
GET VALUE VOLTAGE P13	Print value of receiver supply voltage +13 V.
GET VALUE VOLTAGE P12	Print value of general internal supply voltage +12.5 V.
GET VALUE VOLTAGE P5G	Print value of general internal supply voltage +5 V.
GET VALUE VOLTAGE P5R	Print value of receiver supply voltage +5 V.
GET VALUE VOLTAGE M13	Print value of receiver supply voltage -13 V.
GET VALUE VOLTAGE M12	Print value of general internal supply voltage -12.5 V.
GET VALUE VOLTAGE M5R	Print value of receiver supply voltage -5 V.
GET VALUE VOLTAGE M5G	Print value of general internal supply voltage -5 V.
GET VERSION	Print identifier for software version.
START	Start single-cycle measurement in operation mode STANBY. Refer to command SET OPER_MODE STANDBY.

Table 8 Advanced Level Commands

Command	Description
BACK	Back to normal user command set.
RESET NO	Do not reset.
RESET YES	Make full reset.
SET ALGORITHM DFAULTS	Set default algorithm parameter settings.
SET DATA_ACQ AUTOADJ ON	Data acquisition parameters are software controlled.
SET DATA_ACQ AUTOADJ OFF	Data acquisition parameters are manual controlled.
SET DATA_ACQ COMP COARSE <i>value</i>	Set internal crosstalk compensation setting coarse code value.
SET DATA_ACQ COMP FINE <i>value</i>	Set internal crosstalk compensation setting fine code value.
SET DATA_ACQ TRANSMIT POWER_OF_P <i>value</i>	Set pulse energy input code value.
SET FACTORY INLASER <i>value</i>	Set pulse energy input code value (at startup).
SET FACTORY OUTLASER <i>value</i>	Set pulse energy target value for software adjustment.
SET FACTORY RECVALUE <i>value</i>	Set receiver test reference value.
SET FACTORY WIN_CLEAN <i>value</i>	Set clean window reference value.
SET MESSAGE ANGLE_MEAS AUTO	Automatic angle measurement for angle correction.
SET MESSAGE ANGLE_MEAS MANUAL 0 ... 89	Manual angle value (degrees) for angle correction.
SET MESSAGE MANUAL_MSG "30 01000 02000 03000 12345678"	Set test message (example).
SET MESSAGE MANUAL_MSG " "	Cancel manual message.
SET MESSAGE VLIM 1 ... 100	Set vertical visibility reporting limit (%) for sky condition.
SET OPER_MODE COMP_MONIT	Run internal crosstalk compensation monitor until

Command	Description
	ESC.
SET OPTION SKY_COND ON <i>code</i>	Activate sky condition option with CPU-board specific code number.
SET OPTION SKY_COND OFF	Deactivate sky condition option.
SET OPTION HUMITTER ON	Enable humitter option.
SET OPTION HUMITTER OFF	Disable humitter option.
SET OPTION BLOWER ON	Enable blower related status and warning information, needs reset.
SET OPTION BLOWER OFF	Disable blower related status and warning information.
SET PORT MAINTENANCE PARAMS E71	Set maintenance port character frame to even parity, 7 data bits, 1 stop bit
SET PORT MAINTENANCE PARAMS N81	Set maintenance port character frame to no parity, 8 data bits, 1 stop bit
SET PORT DATA PARAMS E71	Set data port character frame to even parity, 7 data bits, 1 stop bit
SET PORT DATA PARAMS N81	Set data port character frame to no parity, 8 data bits, 1 stop bit
SET PORT DATA MODEM OFF	Switch modem off and use serial line communication
SET SW_STATUS OK	Set report / algorithm conflict status bit ok.
GET DMC_SN	Print DMC50 board serial number.
GET SW_STATUS	Print report / algorithm conflict status bit.
GET VALUE OTHERS RECVALUE	Print measured receiver test values.
GET VLIM	Print sky condition vertical visibility reporting limit (%).
STOP	Stop internal compensation routine.

Data Messages

The following standard messages are provided:

Data message No. 1, 2, 3, 6 and 7.

Status message S.

Each port can be set to transmit a specified message automatically. Alternatively the port can be set to transmit the set message only when polled by a predetermined polling string of characters, or the polling string can contain the message identification.

NOTE

All characters are 7-bit USASCII.

↵ symbolizes Carriage Return+Line Feed (2 characters) throughout this document.

Start-of-Header, Start-of-Text, End-of-Text, Carriage Return and Line Feed are non-printing characters in most practical terminal use.

Data Message No. 1

This message is intended for cloud height/vertical visibility measurement when no other measurement information is desired. The message includes the most elementary status information, which enables a host system or operator to see that no warnings or alarms are present. An example of data message no.1 is presented below:

☎CTA2010☺↓	1st line	11 char.
30 01230 12340 23450 FEDCBA98↓	2nd line	31 char.
☺↓	3rd line	3 char.

	total	44 characters

Transmission time and size :

0.18 s at 2400 baud (10-bit char.)

10.6 kbytes/h, 253 kbytes/d, 7.6 Mbytes/mo. at 4 msg./min.,
uncompressed.

Interpretation of the message is as follows :

1ST LINE

Example: ☎CTA2010☺↓

where

- ☎ = Start-of-Heading character
- CT = Ceilometers' identification string; always CT
- A = Unit number 0...9, A...Z
- 20 = Software level id 00...99
- 1 = Message number; this message is always = 1
- 0 = Spare character for future subclasses of message
- ☺ = Start-of-Text Character

2ND LINE

Example: 30 01230 12340 23450 FEDCBA98↵

where

3	= First digit of line:	Detection status as follows:
	0	No significant backscatter
	1	One cloud base detected
	2	Two cloud bases detected
	3	Three cloud bases detected
	4	Full obscuration determined but no cloud base detected
	5	Some obscuration detected but determined to be transparent
	/	Raw data input to algorithm missing or suspect
0	= Second digit of line:	Warnings and Alarm information as follows:
	0	Self-check OK
	W	At least one Warning active, no Alarms
	A	At least one Alarm active
01230	= If detection status is 1, 2 or 3:	Lowest cloud base height
	If detection status is 4:	Vertical Visibility as calculated
	If detection status is 0 or 5:	////
12340	= If detection status is 2 or 3:	Second lowest cloud base height
	If detection status is 4:	Highest signal detected
	If detection status is 0, 1 or 5:	////
23450	= If detection status is 3:	Highest cloud base height
	If detection status is 0, 1, 2, 4, 5:	////
FEDC	= Alarm (A), Warning (W), and internal status information. Each character is a	
BA98	hexadecimal representation of four bits, i.e. values between 0 and 9 are presented with respective numbers and values 10, 11, 12, 13, 14, and 15 are presented with letters A, B, C, D, E, and F, respectively. As each character represents the sum of four individual bits, the total number of bits is 32 (b00-b31), with the following breakdown and interpretation:	
F:	b31 (8000 0000)	Laser temperature shut-off (A)
	b30 (4000 0000)	Laser failure (A)
	b29 (2000 0000)	Receiver failure (A)
	b28 (1000 0000)	Voltage failure (A)
E:	b27 (0800 0000)	(spare) (A)
	b26 (0400 0000)	(spare) (A)
	b25 (0200 0000)	(spare) (A)
	b24 (0100 0000)	(spare) (A)
D:	b23 (0080 0000)	Window contaminated (W)
	b22 (0040 0000)	Battery low (W)
	b21 (0020 0000)	Laser power low (W)
	b20 (0010 0000)	Laser temperature high or low (W)
C:	b19 (0008 0000)	Internal temperature high or low (W)

	b18	(0004 0000)	Voltage high or low (W)
	b17	(0002 0000)	Relative Humidity is > 85 % (option) (W)
	b16	(0001 0000)	Receiver optical cross-talk compensation poor (W)
B:	b15	(0000 8000)	Blower suspect
	b14	(0000 4000)	(spare) (W)
	b13	(0000 2000)	(spare) (W)
	b12	(0000 1000)	(spare) (W)
A:	b11	(0000 0800)	Blower is ON
	b10	(0000 0400)	Blower heater is ON
	b09	(0000 0200)	Internal heater is ON
	b08	(0000 0100)	Units are METERS if ON, else FEET
9:	b07	(0000 0080)	Polling mode is ON
	b06	(0000 0040)	Working from battery
	b05	(0000 0020)	Single sequence mode is ON
	b04	(0000 0010)	Manual settings are effective
8:	b03	(0000 0008)	Tilt angle is > 45 degrees
	b02	(0000 0004)	High background radiance
	b01	(0000 0002)	Manual blower control
	b00	(0000 0001)	(spare)

For example, if the window is contaminated, the battery voltage is too low, the internal heater is on and units are meters, a warning is given and the second line appears as

```
0W //// //// //// 00C00300
```

3RD LINE

⊙ ↵ End-of-Text and CRLF

Data Message No. 2

Data message no. 2 contains the range and sensitivity normalized backscatter profile within a range of 0 ... 25000 ft, which makes it suitable for e.g. graphical plotting of the atmosphere.

Data resolution is 100ft = 30 m with distance, and 16 bits (four hex-ASCII characters) with signal magnitude.

NOTE

Message no. 2 should not be used with slow baud rate and short data acquisition interval; this may lead to overflow of the transmit buffer. E.g. 300 baud rate requires 45 sec. data acquisition interval with message 2. In case the buffer is filling up, the response time to user command may extend to minutes.

Measurement parameters are mostly in engineering units. Plus and minus signs are possible. Out-of-Range is indicated by slashes (/////).
 Contents:

- 100 Parameter SCALE, 100 (%) is normal (0...999 possible).
- N Measurement mode; N = Normal, (C = Close range, not available in CT25K).
- 53 Laser pulse energy, % of nominal factory setting (0 ... 999).
- +34 Laser temperature degrees C (-50 ... +99).
- 204 receiver sensitivity, % of nominal factory setting (0...999).
- 146 Window contamination, millivolts at internal ADC input (0...2500).
- +2 Tilt angle, degrees from vertical (-15 ... +90).
- 621 background light, millivolts at internal ADC input (0 ... 2500).
- LF7HN1 Measurement parameters (pulse Long/Short, freq F (const.), pulse qty 4^{7+1} , gain High/Low, bandwidth Narrow/Wide, sampling 10/20 MHz).
- 139 SUM of detected and normalized backscatter, 0 ... 999. Multiplied by scaling factor times 10^4 . At scaling factor 100 the SUM range 0 ... 999 corresponds to integrated backscatter 0...0.0999 srad^{-1} .

4TH...19TH LINE

Backscatter profile, sensitivity and range normalized, at 100 ft = 30 m resolution, normally scaled to units of $(10000 \cdot \text{srad} \cdot \text{km})^{-1}$.

Example of 8th line:

```
064FD FDFDFDFDFDFCF CFCFCFCFCFCFCFCFCFBFBFBFBFBFBFBFBFAFBFAFBFBFAFAFBFAF9FAF9J
```

where

- 064 = Is start distance (height) of line backscatter data items; decimal, unit is 100ft = 30m = 200ns (two-way).
- FDFC, FBFA, ... = Are 16 four-character data items per line, at 100ft = 30m = 200ns resolution; 16-bit HEX-ASCII; msb nibble and bit first. 2's complement. Data is range and sensitivity normalized backscatter, units $(10000 \cdot \text{srad} \cdot \text{km})^{-1}$ unless otherwise scaled by parameter SCALE.

20TH LINE

⊙⌵ End-of-Text and CRLF.

Data Message No. 3

This message contains a line which has one bit for each range gate at 100 ft resolution. It is intended for printer-type black-and-white graphical recorders such as Vaisala DR23, DD50 with printer, etc. The message is derived from Message no. 2 by setting a threshold for the range and sensitivity normalized backscatter profile and reporting signal exceeding this threshold as a 1, and otherwise as a 0. The bit line gets split into groups of four successive range gates, which are then transmitted as a string of 64 hexadecimal characters 0..F.

Message format example:

CTA2033☺↓	1st line	11 char.
30 01230 12340 23450 FEDCBA98↓	2nd line	31 char.
00002204FFFEFF8C00000000627EEFFF310000000335A0BFFFFF100000000000↓	3rd line	66 char.
☺↓	4th line	3 char.

	total 111 characters	

Transmission time and size :

0.46 s at 2400 baud (10-bit char.)

26.64 kbytes/h, 639 kbytes/d, 19.18 Mbytes/mo. at 4 msg./min.,
uncompressed.

Message interpretation:

1ST LINE

Identical to that of Message No. 1 except that the second to last digit which identifies the message number, is always 3.

2ND LINE

Identical to that of Message No. 1

3RD LINE

Example:

```
00002204FFFEFF8C00000000627EEFF310000000335A0BFFFFF1000000000000↓
```

64 hexadecimal characters 0...F, each bit in its binary format representing one of four subsequent range gates at 100 ft (30 m) resolution. Bit is set to "1" if its internal unscaled value (in units of $(10,000 \text{ km srad})^{-1}$, ref. message no. 2) exceeds $1,000 * 100/\text{SCALE}$, i.e. maximizing the value of parameter SCALE to 999 minimizes the threshold, and thus, maximizes recording sensitivity to a backscatter value of $100 / (10,000 \text{ km srad})$.

4TH LINE

Identical to the 3rd line of message no. 3.

Data Message No. 4

Data message no. 4 is not in use.

Data Message No. 5

Data message no. 5 is not in use.

Data Message No. 6

Message number 6 is similar to message number 1 but extended with a sky condition line (see section Sky Condition Algorithm on page 102). For interpretation, see section Data Message No. 1 on page 46.

Message number 6 format example:

☎CTA2060☺↓	1st line	11 char.
30 01230 12340 23450 FEDCBA98↓	2nd line	31 char.
3 055 5 170 0 /// 0 ///↓	3rd line	30 char.
☺↓	4rd line	3 char.

	total	75 characters

Transmission time and size :

total 75 characters

=> 0.31 s at 2400 baud (10 bit char.)

=> 18.0 kBytes/h, 432 kBytes/d, 12.7 MBytes/mo. at 4 msg/min,
uncompressed

Message interpretation :

LINES 1 and 2 are identical to that of Message number 1.

LINE 3

Example: 3 055 5 170 0 /// 0 ///

where

- 3 = The first number of line: detection status as follows:
 - 0 ... 8 Cloud amount of the first layer in oktas.
 - 9 Vertical visibility.
 - 1 Data missing or the ceilometer is in standby mode.
 - 99 Not enough data (after start-up).
- 055 The second number of line: Height of the 1st cloud layer (5 500 ft or 550 m depending on feet or meter selection).
- 5 The third number of line: Cloud amount of the 2nd layer in oktas.
- 170 The fourth number of line: Height of the 2nd cloud layer (17 000 ft or 1 700 m depending on feet or meter selection).
- 0 The fifth number of line: Cloud amount of the 3rd layer in oktas.
- /// The sixth number of line: Height of the 3rd cloud layer.
- 0 The seventh number of line: Cloud amount of the 4th layer in oktas.
- /// The eighth number of line: Height of the 4th cloud layer.

Status Message "S"

The Status Message displays internal monitoring of the whole unit including prevailing parameter values for voltages, receiver and transmitter, temperatures, environmental factors, and internal heating. The message is meant mainly for testing and maintenance purposes. The internal diagnostics part of the Status Message can also be displayed by giving the command GET STATUS.

An example of the status message is presented below:

	Line	Characters
☎CTA38S0☎↓	1	11
0W ///// ///// ///// 00400200↓	2	31
VOLTAGES (UNIT 0.1V) ↓	3	22
P12 125 M12 -126 P5G 54 M5G -54 VCA 225↓	4	41
P13 128 M13 -124 P5R 50 M5R -50 BAT*098↓	5	41
P18 178 PHV 2306 PFB 17 P65 674 CHA 144↓	6	41
↓	7	2
RECEIVER TRANSMITTER↓	8	27
GAIN H PLEN L↓	9	22
BAND N PQTY 64K↓	10	24
SAMP 10MHz OUT 1416mV↓	11	27
SENS OK SENS 101%↓	12	25
COMP 013 125 IN 190↓	13	24
↓	14	2
TEMPERATURES ENVIRONMENT↓	15	27
BLOWER +20C WINDOW 210mV 102%↓	16	36
CPU +34C RADIANCE +60mV↓	17	31
LASER +29C ANGLE +3DEG (M) ↓	18	35
LENS +34C HUMIDITY NONE↓	19	29
OUTSIDE +23C↓	20	14
INHEATER ON OUTHEATER OFF BLOWER OFF↓	21	39
☎↓	22	3
	-----	-----
	Total	554 characters

NOTE

An asterisk (*) in front of a variable indicates that an alarm or warning limit of that variable is exceeded. In the example above the battery voltage is too low.

(M) is shown after the ANGLE value only if the manual angle setting is used.

Interpretation of the status message is as follows:

1ST LINE

Identical to that of message no. 1 except that the second to last character which identifies the message number, is always S.

2ND LINE

Identical to that of message no. 1

LINES 3...6

Measured internal voltages in units of 0.1V, as follows:

BAT	Battery voltage, e.g.	098
CHA	Battery charge voltage, e.g.	144
VCA	Internal raw voltage, e.g.	225
PHV	Receiver high voltage, e.g.	2306
PFB	Rec. switcher feedback voltage, e.g.	17
P65	Transmitter high voltage, e.g.	674
P18	General internal supply voltage, e.g.	178
P13	Receiver supply voltage, e.g.	128
P12	General internal supply voltage, e.g.	125
P5G	General internal supply voltage, e.g.	54
P5R	Receiver supply voltage, e.g.	50
M13	Receiver supply voltage, e.g.	-124
M12	General internal supply voltage, e.g.	-126
M5R	Receiver supply voltage, e.g.	-50
M5G	General internal supply voltage, e.g.	-54

LINES 8...13

Prevailing Receiver and Transmitter settings and variables as follows:

RECEIVER	GAIN	H or L	Gain is High or Low
	BAND	N or W	Bandwidth is Narrow or Wide
	SAMP	10MHz	Sampling rate is 10 MHz
	SENS	OK	Receiver sensitivity OK compared to factory setting
	COMP	13 125	Internal crosstalk compensation setting codes, coarse (013) and fine (125)
TRANSMITTER	PLEN	L or S	Pulse length is Long or Short
	PQTY	64K	Pulse quantity is 64x1024
	OUT	1416mV	Laser pulse energy measured by Optics Monitor is 1416 mV at Monitoring A-to-D Converter input.
	SENS	101%	Measured pulse energy is 101 % of nominal value
	IN	190	Pulse energy control input code is 190

LINES 15...20

Temperature and environment variables as follows:

TEMPERATURE	BLOWER	+20C	Temperature measured at the Window Conditioner blower airfow exit, e.g. +20 deg C
	CPU	+34C	Temperature on the microprocessor (CPU) Board, e.g. +34 deg C
	LASER	+29C	Temperature measured at the laser diode, e.g. +29 deg C
	LENS	+34C	Temperature measured adjacent to the lens, e.g. +34 deg C
	OUTSIDE	+23C	Temperature measured by the external sensor (at connectors), e.g. +23 deg C
ENVIRONMENT	WINDOW	210mV 102%	Value of window contamination measurement, e.g. 210 mV, and ratio in per cent compared to factory setting, e.g. 102 %
	RADIANCE	+60mV	Value of background radiance measurement, e.g. 60 mV
	ANGLE	+3DEG	Value of tilt angle relative to vertical, e.g. +3 degrees. Positive value means that door of the unit tilts towards ground.
	HUMIDITY	NONE	(Relative Humidity in per cent inside the ceilometer if sensor is furnished)

LINE 21

Status of Internal Heater (INHEATER ON/OFF), Window Conditioner Heater (OUTHEATER ON/OFF), Window Conditioner Blower (BLOWER ON/OFF).

LINE 22

⊙↵ End-of-Text and CRLF

Manual Message

The ceilometer can be set to transmit user defined cloud heights and status information. The user can set a cloud message in the format of line 2 of any real cloud message (e.g. Msg 1). The message must be between quotation marks, see example. This message is volatile. The manual message command is behind the password "advanced". Below is an example of a manual message:

```
CEILO>advanced

PASSWORD ACCEPTED !

CEILO>set message manual_msg "30 00200 01000 05000
00000000"

MANUAL MESSAGE: 30 00200 01000 05000 00000000
```

If the given message does not have the correct format, it is not accepted and an error message will follow. To return to the normal measurement mode, give an empty string :

```
CEILO>set message manual_msg ""

MANUAL MESSAGE NOT ACCEPTED

USE FORMAT: "30 00100 02000 15000 00000000"

MESSAGE MODE IS NORMAL MEASUREMENT MODE
```

The manual message is intended for testing purposes. After reset the normal cloud detection mode takes effect.

Polling Mode

A port can be set to transmit a message only when polled by a predetermined polling string of characters. The polling string can contain the message identification.

The CT25K unit can be assigned an identification of one character digit or letter. The factory setting is 0 (zero). The polling mode is activated with the command:

```
CEILO>SET MESSAGE MODE POLLING
```

and return to normal autosend mode is done with command

```
CEILO>SET MESSAGE MODE AUTOSEND.
```

The polling string format is

<Enq> CT*Id*No ↵

where

Enq = Is character ENQUIRE = ASCII 05H = control-E.
 CT = Is fixed ceilometer identifier.
Id = Is identification character, 7-bit printable ASCII character.
No = Is optional message identifier 1, 2, 3, 6, 7, S.
 ↵ = ENTER (Carriage Return) + Line Feed.

Polling command examples :

< Enq > CT11<Enter> Message 1 from ceilometer nr.1
 < Enq > CT12<Enter> Message 2 from ceilometer nr.1
 < Enq > CT1S<Enter> Status message from ceilometer nr.1

NOTE

If the *id* character in a polling string is replaced with a blank space, all ceilometers on the line will respond. Accordingly, if *No* is a blank space, CT25K sends the default message.

Prevailing Parameter Settings

The prevailing control and parameter settings that chiefly determine operation can be seen by the following GET commands. Shown parameter values are equal to standard factory settings but may vary depending on installation in question. Operator input is marked in CAPITAL (Times) letters after the command prompt CEILO> and the Ceilometer response under the operator input as COURIER font.

In case you want to change parameter values see section Factory Settings of User Programmable Parameters on page 35 for settings of user programmable parameters.

```
CEILO>GET ALGORITHM
NOISE SCALE:          1.7
MINIMUM SUM:          30
MINIMUM EXTCO:        6.0
```

CEILO>GET DATA_AQC

AUTOADJUSTMENTS:	ON	
DATA-ACQ. INTERVAL:	15 SEC.	
RECEIVER		
GAIN:	H	*
BANDWIDTH:	N	
SAMPLING RATE:	10 MHz	
TRANSMITTER		
LENGTH OF PULSE:	L	*
POWER OF PULSE:	188	*
QUANTITY OF PULSES:	64K	
COMPENSATION		
COARSE COMPENSATION:	12	*
FINE COMPENSATION:	109	*

CEILO>GET FACTORY

FACTORY		
BEAMSPLITTER:	96%	**
IN LASER:	185	**
OUT LASER:	1200	**
COARSE COMP.:	13	**
FINE COMP.:	125	**
RECEIVER TEST VALUE:	350	**
CLEAN WINDOW:	200mV	**

CEILO>GET MESSAGE

MESSAGE		
ANGLE CORRECTION:	ON	
HEIGHT OFFSET:	0	
NOISE H2	OFF	
COMPENSATION:		
PROFILE SCALE:	100%	
PORT:	DATA	
TYPE:	MSG1	
UNITS:	FEET	
MODE:	AUTOSEND	

```
CEILO>GET OPER_MODE
OPERATION MODE:          CONTINUOUS

CEILO>GET PORT
MAINTENANCE PORT BAUDS: 2400, E71
DATA PORT BAUDS:        300, E71
MODEM:                  CCITT (300)
MODEM STATUS:           ON
YOU ARE USING:          MAINTENANCE PORT

CEILO>GET UNIT_ID
UNIT ID:                 0
```

NOTE

- * Individual values are automatically adjusted by the software.
- ** Individual original factory settings or updated original settings in conjunction with subassembly replacement.

Manual Angle Setting

The automatic tilt angle measurement can be disabled and replaced with a manual value. To set the manual angle value type :

```
CEILO>ADVANCED
PASSWORD ACCEPTED !

CEILO>SET MESSAGE ANGLE_MEAS MANUAL 5
MANUAL ANGLE: 5
```

To check the current state of tilt angle setting, get the status message :

```
CEILO>GET STATUS
VOLTAGES (UNIT 0.1V)
P12 130 M12 -122 P5G 53 M5G -54 VCA 220
P13 126 M13 -121 P5R 49 M5R -48 BAT 121
P18 176 PHV 2755 PFB 20 P65 769 CHA 121
```

RECEIVER	TRANSMITTER		
GAIN H	PLEN L		
BAND N	PQTY 64K		
SAMP 10MHz	OUT 1270mV		
SENS OK	SENS 100%		
COMP 013 125	IN 190		
TEMPERATURES	ENVIRONMENT		
BLOWER	+20C	WINDOW	200mV 100%
CPU	+32C	RADIANCE	69mV
LASER	+28C	ANGLE	+5DEG (M)
LENS	+32C	HUMIDITY	NONE
OUTSIDE	+20C		
INHEATER OFF	OUTHEATER OFF	BLOWER	OFF

(M) after the angle value indicates the use of a manual value.

CHAPTER 5

FUNCTIONAL DESCRIPTION

Theory of Operation

Basic Principle of Operation

The operating principle of the CT25K Ceilometer is based on measurement of the time needed for a short pulse of light to traverse the atmosphere from the Transmitter of the Ceilometer to a backscattering cloud base and back to the Receiver of the Ceilometer.

With the speed of light being:

$$c = 2.99 \times 10^8 \text{ m/s (= 186 000 miles per second)}$$

A reflection from 25,000 ft will be seen by the receiver after

$$t = 50.9 \text{ } \mu\text{s}$$

where c is the speed of light.

Practical Measurement Signal

Generally, particles at all heights backscatter light, and so the actual return signal may look like that shown in Figure 11 on page 64.

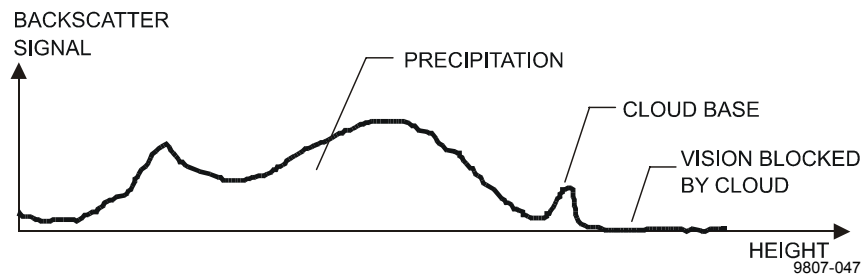

Figure 11 Typical Measurement Signal

The instantaneous magnitude of the return signal will provide information on the backscatter properties of the atmosphere at a certain height. From the return signal, information about fog and precipitation, as well as cloud, can be derived. Since fog and precipitation attenuate the light pulse, the cloud base signal will appear lower in magnitude in the return echo. However, the fog and precipitation information also provides data for estimating this attenuation and computing the necessary compensation, up to a limit.

In its normal full-range operation the CT25K ceilometer digitally samples the return signal every 100 ns from 0 to 50 μ s, providing a spatial resolution of 50 feet from ground to 25,000 feet distance. This resolution is adequate for measuring the atmosphere, since visibility in the densest clouds is in the order of 50 feet.

Noise Cancellation

For safety and economic reasons, the laser power used is so low that the noise of the ambient light exceeds the backscattered signal. To overcome this, a large number of laser pulses are used, and the return signals are summed. The desired signal will be multiplied by the number of pulses, whereas the noise, being random, will partially cancel itself. The degree of cancellation for white (Gaussian) noise equals the square root of the number of samples; thus, the resulting signal-to-noise ratio improvement will be equal to the square root of the number of samples. However, this processing gain cannot be extended ad infinitum since the environment changes. For example, clouds move.

Return Signal Strength

The instantaneous return signal strength is in general form (the Lidar equation):

$$P_r(z) = E_o \cdot \frac{c}{2} \cdot \frac{A}{z^2} \cdot \beta(z) \cdot e^{-2 \int_0^z \sigma(z') dz'}$$

where

- $P_r(z)$ = Is the instantaneous power received from distance z [W = Watt].
- E_o = Is the effective pulse energy (taking all optics attenuation into account) [J = Joule = Ws = Watt - second].
- c = Is the speed of light [m/s = meters per second].
- A = Is the receiver aperture [m²].
- z = Is the distance in question [m].
- $\beta(z)$ = Is the volume backscatter coefficient at distance z [m⁻¹srad⁻¹, srad = steradian].

$$e^{-2 \int_0^z \sigma(z') dz'}$$

Is the two-way atmospheric transmittance and accounts for the attenuation of transmitted and backscattered power by extinction at various distances (z') between transceiver and distance in question (z). The expression equals 1 in a clear atmosphere (i.e., no attenuation).

Height Normalization

Assuming a clear atmosphere, it can be seen that the power is inversely proportional to the square of the distance or height i.e., the strength of a signal from 10,000 ft is generally one-hundredth of that from 1,000 ft.

The height-square dependence is eliminated by multiplying the value measured with the square of the height (height normalization). However, noise, being height-independent from a measurement point of view, will then be correspondingly accentuated with increasing height.

The Backscatter Coefficient

The volume backscatter coefficient, $\beta(z)$, of the Lidar Equation represents the portion of light which is reflected back towards the Ceilometer from a distance z (e.g., by water droplets). It is obvious that the denser a cloud is, the stronger the reflection will be. The relationship can be expressed as:

$$\beta(z) = k \cdot \sigma(z)$$

where

k = Is a "constant" of proportionality.

$\sigma(z)$ = Is the extinction coefficient (i.e., the attenuation factor in a forward direction).

The extinction coefficient relates to *visibility* in a straightforward manner. If visibility is defined according to a 5 % contrast threshold (World Meteorological Organization definition for Meteorological Optical Range MOR, equals daylight *horizontal* visibility), then

$$\sigma = 3 / V$$

where

σ = Is the extinction coefficient

V = Is MOR visibility (5 % contrast).

The "constant" of proportionality, k , also called the Lidar Ratio, has been subjected to a lot of research. Although the Lidar Equation can be solved without knowing its value, it must remain constant with height if accurate estimates of the extinction (or visibility) profile are to be made.

It has been found that in many cases, k can be assumed to equal 0.03, tending to be lower in high humidities, to 0.02; and higher in low humidities, to 0.05. However, in e.g. precipitation of various kinds, k will have a wider range of values.

Assuming a value 0.03 (srad^{-1}) for k and visibility in clouds being in the range 15 ... 150 m (50 ... 500 ft) gives the range of value for β :

$$\beta = 0.0006 \dots 0.006 \text{ m}^{-1}\text{srad}^{-1} = 0.6 \dots 6 \text{ km}^{-1}\text{srad}^{-1}$$

Extinction Normalization and Vertical Visibility

Any fog, precipitation, or similar obstruction to vision between ground and cloud base may attenuate the cloud base signal and produce backscatter peaks that far exceed that from the cloud. Virtually any backscatter height profile is possible, up to some physical limits. To distinguish a significant cloud return signal, the attenuation of fog, precipitation, etc., has to be taken into account by normalizing with regard to extinction. The profile thus obtained is proportional to the extinction coefficient at various heights, and enables the use of fairly straightforward threshold criteria to determine what is cloud and what is not.

By assuming a linear relationship between backscatter and extinction coefficient according to the previous formula and that the ratio, k , is constant over the range observed, it is possible to obtain an extinction coefficient profile through a mathematical computation. This is also called *inverting* the backscatter profile to obtain the extinction coefficient profile, and answers the question, "What kind of extinction coefficient profile would produce the backscatter profile measured?".

No assumption as to the absolute value of the ratio, k , needs to be made if k is constant with height. The assumptions that have to be made are fairly truthful, and in any case accurate enough for the purpose of cloud detection.

Likewise, the inversion is also independent of several instrumental uncertainties including transmitted power and receiver sensitivity.

An estimate of *Vertical Visibility* can easily be calculated from the extinction coefficient profile because of the straightforward extinction coefficient-to-visibility relationship, provided that a constant contrast threshold is assumed. Visibility will simply be that height where the integral of the extinction coefficient profile, starting from ground, equals the natural logarithm of the contrast threshold, sign disregarded.

Tests and research have, however, shown that the 5 % contrast threshold widely used for horizontal measurement is unsuitable for vertical measurement if values close to those estimated by a ground-based observer are to be obtained.

The CT25K uses a contrast threshold value which, through many tests, has been found to give Vertical Visibility values closest to those reported by ground-based human observers. A wide safety margin is

obtained with regard to pilots looking down in the same conditions since the contrast objects, especially runway lights, are much more distinct on the ground.

Technical Description

General

Figure 12 below shows the internal layout of the Measurement Unit and the following Figure 13 on page 69 the subassembly interconnections. Summary of part numbers and subassemblies is listed in Table 9 on page 69. The technical description is split into subparagraphs according to Unit Block Diagram illustrated in Figure 14 on page 71. For more detailed block diagrams and descriptions, see section Module Descriptions on page 74.

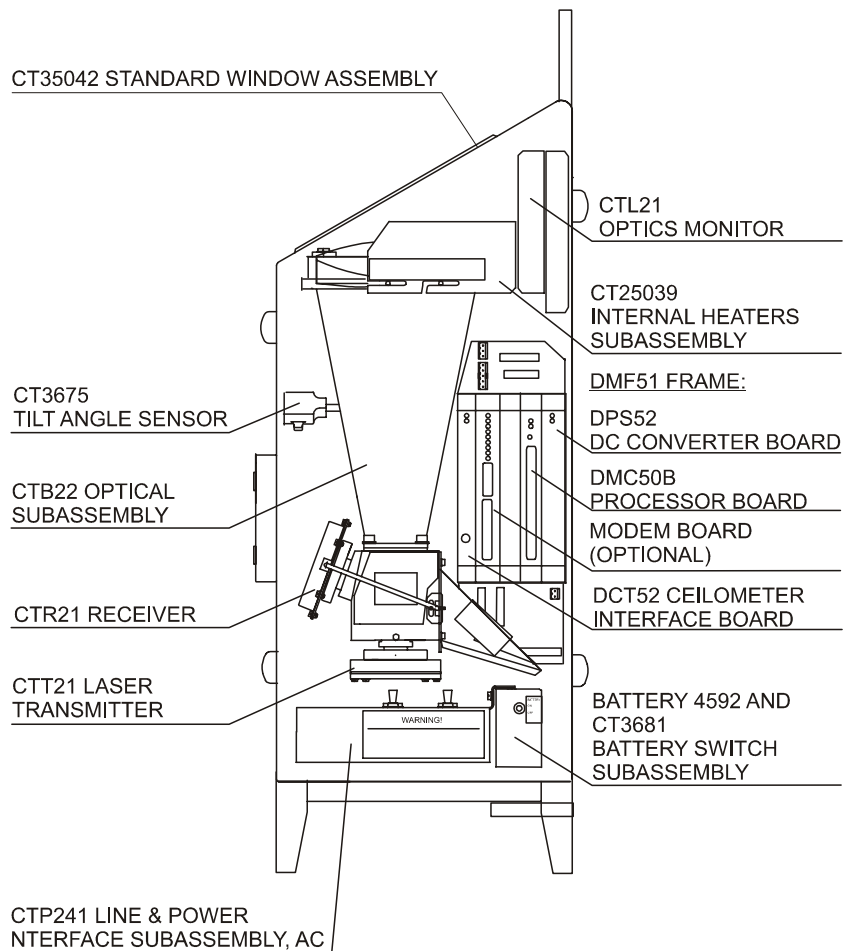

9412-035

Figure 12 Measurement Unit Components

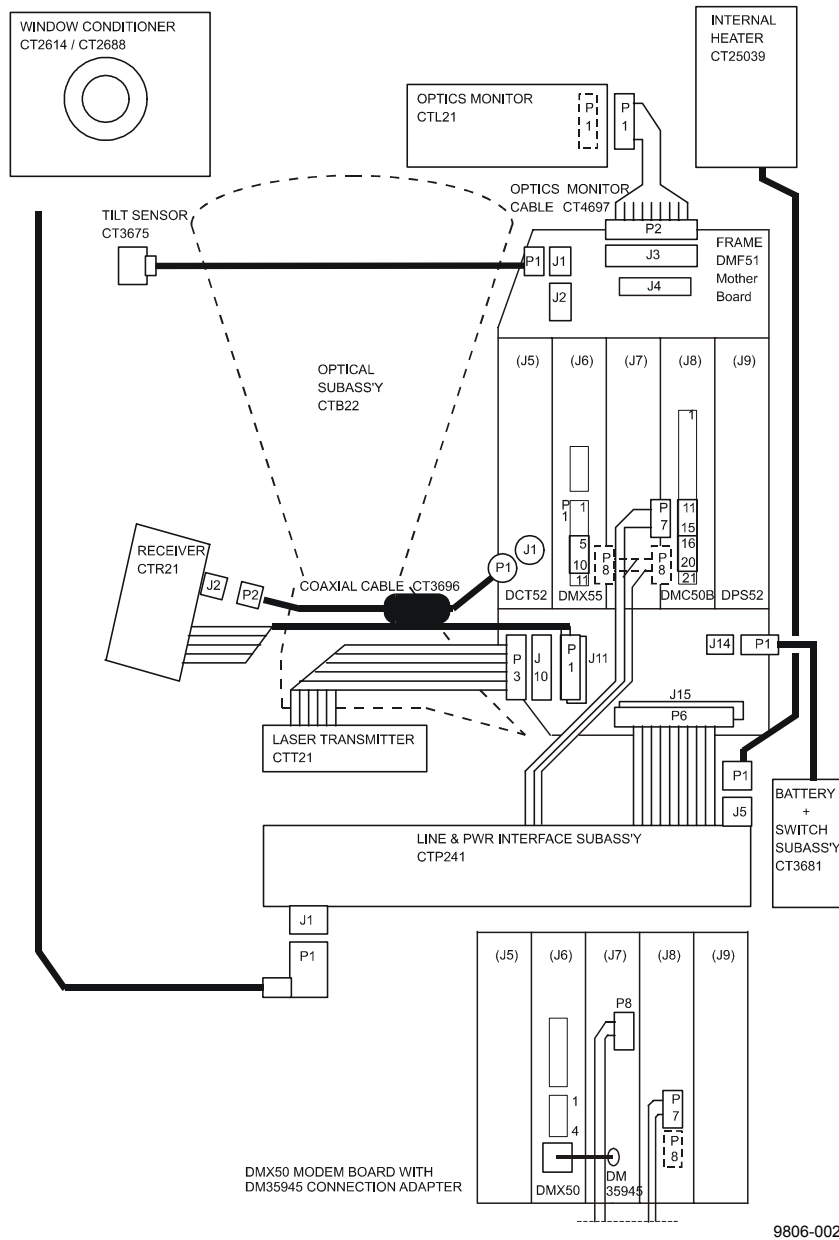

9806-002

Figure 13 Subassembly Interconnections

Table 9 Parts List

Part no.	Description	Notes
CT15035	ENCLOSURE	
CT35042	STANDARD WINDOW	
CT35043	TROPICS WINDOW	Specified at order
CTP241	LINE & PWR INTERFACE SUBASSEMBLY, AC	
4592	BATTERY	
CT25039	INTERNAL HEATERS SUBASSEMBLY	
CT3675	TILT ANGLE SENSOR	

Part no.	Description	Notes
CTB22	OPTICAL SUBASSEMBLY	
CTT21	LASER TRANSMITTER	
CTR21	RECEIVER	
CTL21	OPTICS MONITOR	
CT25015	COMPENSATION FIBER	
DMF51	BOARD FRAME	
DMC50B	PROCESSOR BOARD	
DPS52	DC CONVERTER BOARD	
DCT52	CEILOMETER INTERFACE BOARD	
DMX55	MODEM BOARD	Specified at order
DMX50	MODEM BOARD	Specified at order
DM35945	DMX50 CONNECTION ADAPTER	
CT3681	BATTERY SWITCH SUBASSEMBLY	
CT3696	COAXIAL CABLE	
CT4697	OPTICS MONITOR CABLE	
CT1679	SHIELD	
CT2614	BLOWER 230 VAC	Specified at order
CT2688	BLOWER 115 VAC	Specified at order
CT25106	PEDESTAL, metal	Specified at order
CT2665	PEDESTAL, fiberglass	Specified at order
CT3839	POWER LINE CABLE	
CT3838	DATA CABLE	
CT3709	POWER TERMINATION BOX	Specified at order
CT3707	SIGNAL TERMINATION BOX	Specified at order
TERMBOX-1200	TERMINATION BOX, POWER&SIGNAL	Specified at order
PSION	MAINTENANCE TERMINAL	Specified at order
CT35198	PC TERMINAL CABLE	Specified at order
17430	DOOR KEY SOUTHCO E3-3	
CT45155	ALLEN KEY 6mm	
CT25KWBK	WEDGE BOLT KIT	
CT25184	OPTICAL TERMINATION HOOD	Specified at order
CT35022	SHOCK ABSORBER	Specified at order
CT25338	BIRD COLLAR	Specified at order

LIDAR Measurement

Refer to block diagram in Figure 14 on page 71. Top level control resides in the software of Processor Board DMC50B. This determines what settings are to be used for the measurement. The settings are written by the software into Ceilometer Interface Board DCT52, which then carries out the actual measurement autonomously. When the measurement is complete, an interrupt is issued from the DCT52 to the DMC50B, upon which the accumulated measurement backscatter raw data profile is fetched by the DMC50B into its RAM for the algorithmic processing.

Laser pulse 100 ns
 Energy 1.6 μ J
 Repetition rate 5.57 kHz
 Number of pulses 65,536
 Measurement time 11.7 s
 Receiver on High Gain
 Bandwidth 3 MHz
 Sampling at 100 ns
 500 useful samples per laser pulse
 Measurement range 0 ... 25,000 ft. (0 ... 7.5 km)

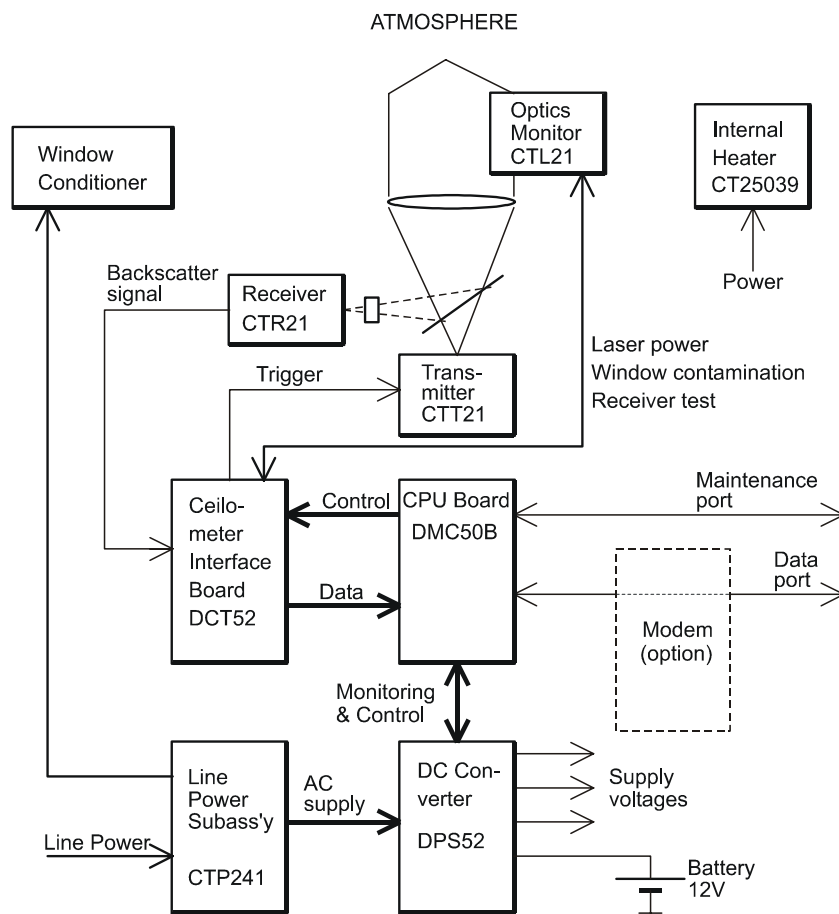

9806-003

Figure 14 Block Diagram of Operational Units

In addition, there is another mode for carrying out a simulated measurement without laser, with the Light Emitting Diode (LED) of the Optics Monitor CTL21 acting as the simulated backscatter. This mode serves for testing the whole receiver section.

When the measurement starts, the Timing and Control logic of the DCT52 starts issuing trigger pulses to the Laser Transmitter CTT21 at

the specified repetition rate. At each trigger pulse the transmitter sends out one laser pulse. This laser pulse gets collimated by the lens into a near-parallel beam of light. As this short laser beam traverses the atmosphere, particles cause scatter in the backward direction, a part of which hits the lens and gets focussed by it. The beamsplitter reflects a fixed fraction of it through the Infrared Interference Filter onto the Avalanche Photodiode (APD) of the Receiver CTR21. The Infrared Interference Filter eliminates all background light noise outside the laser wavelength band.

The APD transforms the backscatter photons into electrical current at a fixed ratio. This current gets amplified in the transimpedance-type Receiver Amplifier to a voltage, which is fed into the Flash Analog-to-Digital Converter (ADC) of the Ceilometer Interface Board DCT52. This ADC converts the analog voltage to 8-bit digital bytes at the specified sampling rate. These digital samples then get added into the First-In-First-Out (FIFO) register of the DCT52. This FIFO is cleared to all-zeroes before start; its data content is rotated so that a sample from a specific distance (specific delay time after the laser pulse launch) always gets summed into the same rotating and accumulating register location. Thus the sequential summing of new samples gradually creates a high-resolution digital image of the backscatter profile. Noise, being random, increases only in proportion to the square root of the number of samples, whilst the effective signal increases in direct proportion to the number of samples. Thus, the final digital profile will reveal properties of the atmosphere that couldn't be seen from an instantaneous signal.

At the end of the set number of pulses the DCT52 issues an interrupt to the DMC50B, upon which the software fetches the digital profile to its RAM for the algorithmic processing. After processing, the measurement result is ready for message transmission through the data link to the equipment it connects to.

In conjunction with the backscatter measurement the laser pulse energy is also measured by the Optics Monitor CTL21 photodiodes. The measured value is used by the algorithm for normalizing the profile into the right magnitude, for adjusting the laser voltage by the Digital-to-Analog Converter (DAC) placed on the DCT52, and ultimately, for warning or alarming of loss of laser power.

During the exit of the laser pulse, a small fraction of energy is also reflected back into the receiver by the optics surfaces of the unit. Due to the tremendous sensitivity of the receiver, this optical cross-talk could seriously distort the profile, and therefore it needs to be neutralized. This is done by a secondary APD, which gets its input from an optical fiber light guide placed so that it only sees the

outgoing laser pulse but not the backscatter. The two APD's are connected in a half-bridge configuration, whereby most of the optics cross-talk signal is subtracted from the measurement signal. For best possible balancing of the bridge, the compensating APD gain is under software control through the DAC of the DCT52. The backscatter measurement sampling actually starts before the launch of the laser pulse, and thus the resulting distortion is visible to the software in the raw measurement profile, and this is iteratively kept within limits.

Internal Monitoring and Control

All essential subassembly functions are monitored continuously to ensure measurement accuracy and reliability. Temperature, laser performance etc. is measured by sensors and transferred to Processor Board DMC50B, converted from analog to digital by its Monitor A-to-D Converter and further analyzed by the processor software.

Warning and Alarm limits are defined in software through parameter settings. In case a malfunction has been detected, i.e. the limits have been exceeded, the software sends warning and alarm messages which can be seen by the STATUS message (see section Status Message "S" on page 55).

Module Descriptions

Optical Subassembly CTB22

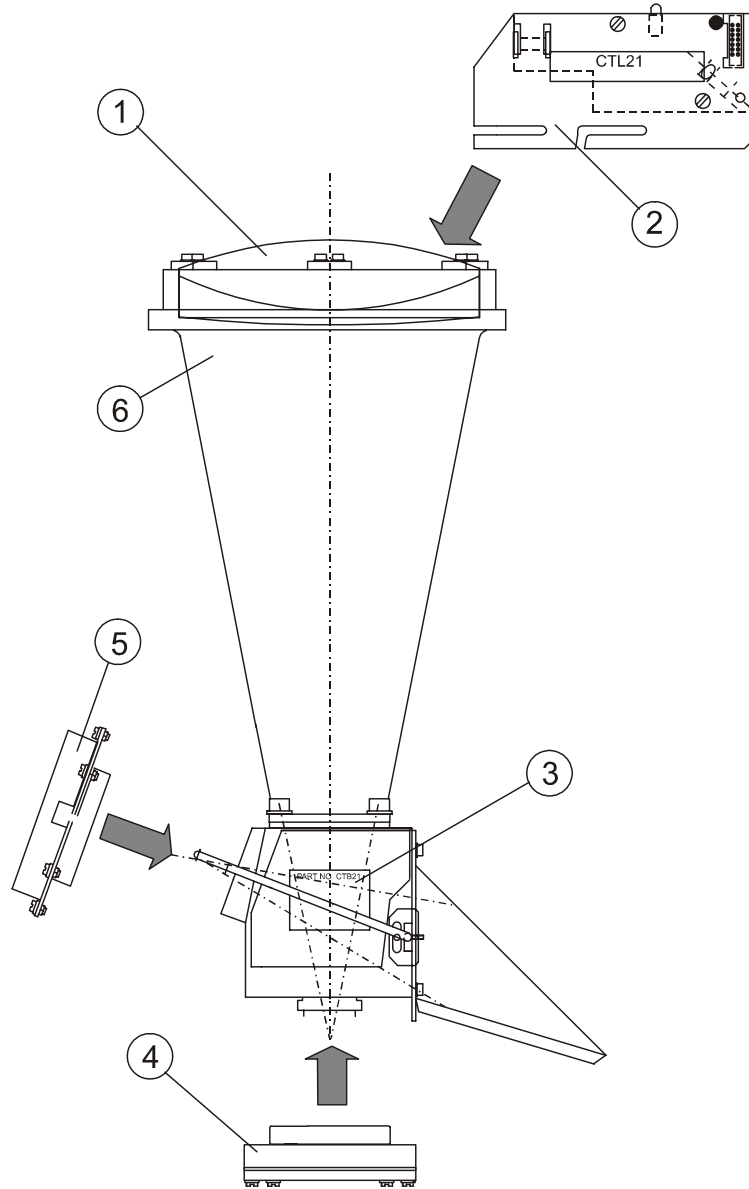

0208-067

Figure 15 Optical Subassembly CTB22 with Optics Monitor, Transmitter and Receiver Subassemblies

The following numbers refer to Figure 15 on page 74:

- 1 = Lens
- 2 = CTL21 Optics monitor
- 3 = CT3656 Compensation fiber
- 4 = CTT21 Laser transmitter
- 5 = CTR21 Receiver
- 6 = CTB22 Optical subassembly

Description

The optical subassembly consists of the following major units: the conical optical tube with fixture for the lens, a precise beam integrator block at the lower end including a beamsplitter and a narrow-band filter, and a connection flange for the laser transmitter and receiver subassemblies.

The receiver and transmitter subassemblies are factory-aligned and focused to the optimum. They can be replaced any time by new assemblies without need for readjustment. The adjustment necessary for the compensation of the optical crosstalk after replacement of the receiver or transmitter subassembly can be made by means of a graphical presentation on a maintenance terminal.

At the upper end of the optical tube is the Optics Monitor for control of the laser performance, window contamination and temperature.

Laser Transmitter CTT21

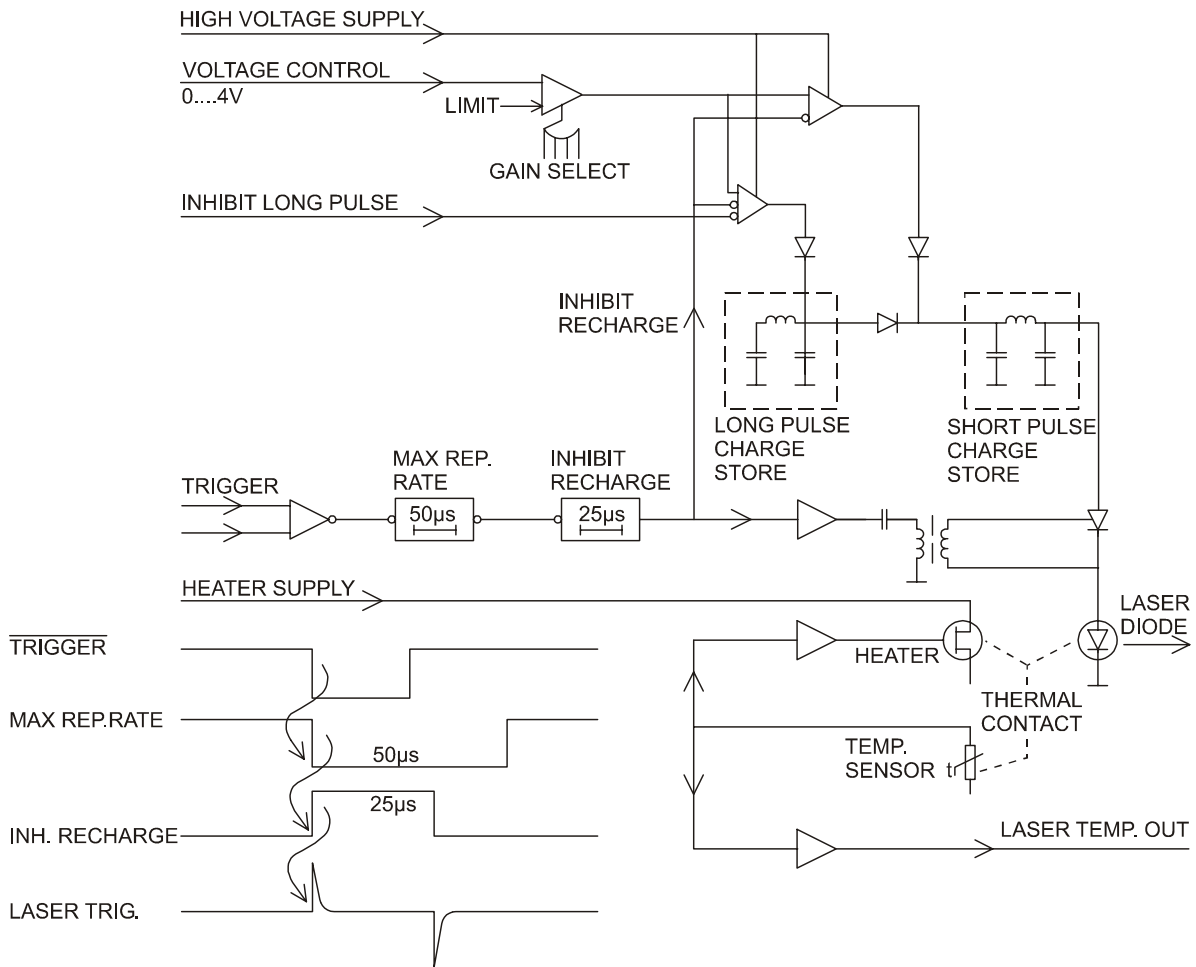

9412-058

Figure 16 CTT21 Block Diagram

Description

An unregulated supply voltage P65 is brought to the Laser Transmitter CTT21 and adjusted to a suitable level by means of an internal voltage regulator. The laser diode of the subassembly is supplied with this regulated high voltage. A trigger pulse is routed through a transformer to the trigger electrode of the switching thyristor for driving a current pulse through the laser diode. A special pulse-forming network makes this current pulse near-rectangular. A small control circuit with a temperature sensor and a heating element ensures the correct laser temperature. The laser temperature is also routed to the Ceilometer Interface Board DCT52 and Processor Board DMC50B for internal monitoring.

WARNING

Dangerous voltages are present in this instrument. Use extreme caution when handling, testing, and adjusting.

Laser Safety

To guarantee the eye safety of the laser equipment, the cable connecting the subassembly is short, permitting operation only when the installation is complete. For removing the laser transmitter subassembly, the cable between the transmitter and the laser interface board must be disconnected first.

Receiver CTR21

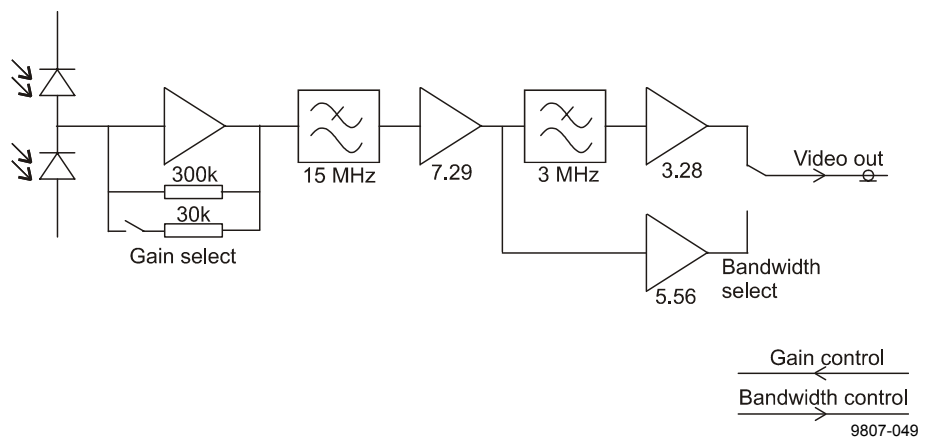

Figure 17 CTR21 Block Diagram

The Receiver subassembly CTR21 consists of two identical avalanche photo diodes (APDs). The second APD compensates most of the optical cross-talk appearing in the lens system through signal reflection by means of a half-bridge connection. The first APD receives the actual measuring signal and sends the pulse current through a transimpedance amplifier with selectable gain. At the output of this amplifier the signal is a voltage signal transferred further through a filter with a frequency limit of 15 MHz to a second signal amplifier. According to the operating mode the signal goes further to a new amplifier stage or to a combined additional filter with a frequency limit of 3 MHz and an amplifier.

The amplifier gain is selected by the system automatically so that the smallest noise signal appearing in the measurement signal is bigger than the resolution of the flash AD converter of the Ceilometer

Interface Board DCT52. The biggest measurement signal must not exceed the full measurement range of the flash AD converter. The gain control as well as the bandwidth selection are automatic and controlled by the processor software and the DCT52.

WARNING Dangerous voltages are present in this instrument. Use extreme caution when handling, testing, and adjusting.

Optics Monitor CTL21

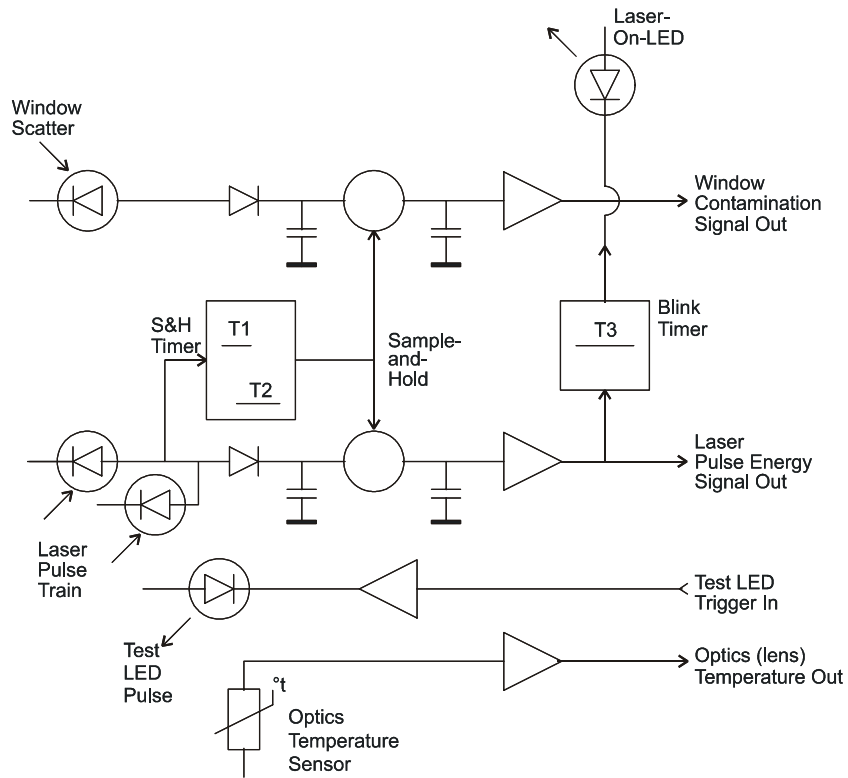

9807-048

Figure 18 CTL21 Block Diagram

The laser pulse train sent from the laser transmitter CTT21 is monitored by two PIN photodiodes. After a corresponding amplification and AD conversion on the processor board, the signal is used as a control signal for the laser output power. The pulses also give a start signal for a sample & hold circuit, which, through a further photodiode, measures the light reflected back from the window due to contamination. This signal is also transferred further to the processor board A-to-D Converter and software, to give an indication of window

contamination. A Blink Timer controls an LED indicator which indicates when the laser is switched on, i.e. sends laser pulses.

For testing of the complete receiver subsystem a short pulse is sent from a test LED in the direction of the receiver. The control signal for triggering the test LED is given from the ceilometer interface board DTC52. The optics is heated in order to protect it against condensed humidity. A temperature sensor delivers a control signal for the heating via an amplifier, processor board A-to-D Converter, and software.

Board Frame DMF51

The frame DMF51 is a subassembly into which the Processor Board DMC50B, Ceilometer Interface Board DCT52, DC Converter DPS52 and the optional modem are plugged. Its mechanical construction suits well for housing printed circuit boards. Being fully metallic, it protects the electronics against electromagnetic disturbances (see Figure 19 on page 80).

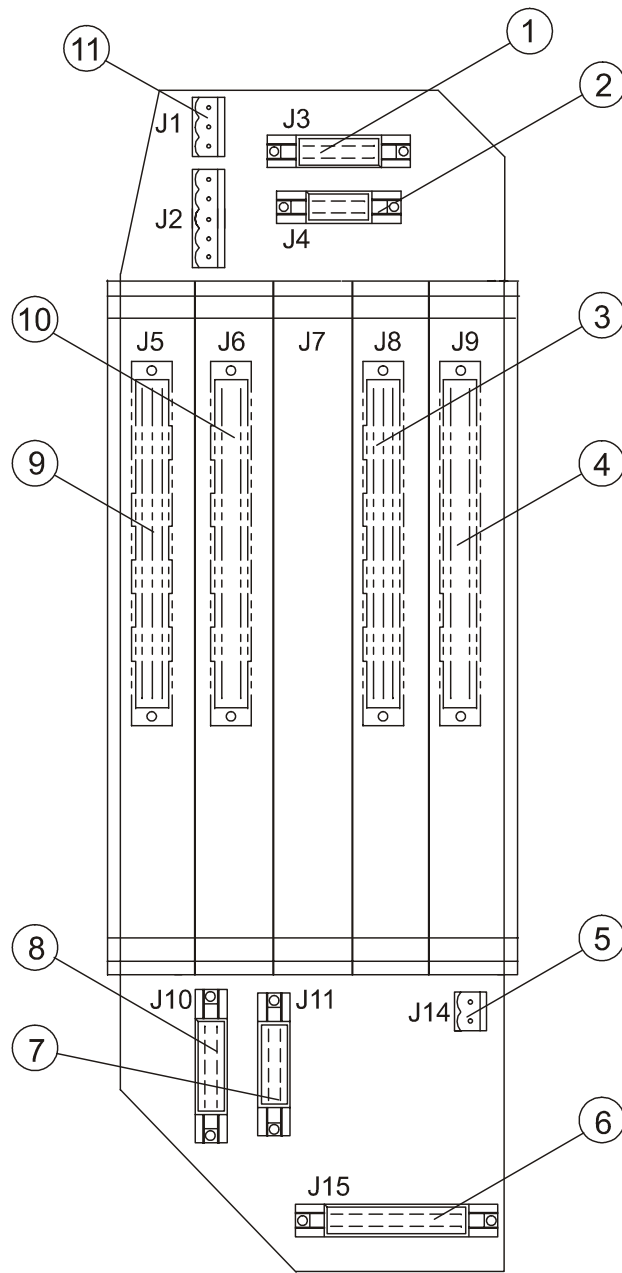

0208-068

Figure 19 DMF51 Frame

The following numbers refer to Figure 19 on page 80:

- 1 = J3 Optics monitor
- 2 = J4 Local display
- 3 = DMC50B Processor board
- 4 = DPS52 DC converter board
- 5 = J14 12V local battery
- 6 = J15 AC power interface
- 7 = J11 Receiver
- 8 = J10 Transmitter
- 9 = DCT52 Ceilometr interface board
- 10 = Modem board (optional)
- 11 = J1 Tilt angle sensor CT3675

The printed circuit boards are of size 100 x 144 mm. Each board is provided with a front panel that is securely fastened with two screws to the frame, simultaneously providing a good electrical ground connection.

The connections between the separate plug-in boards are realized by means of a motherboard and multiple board connectors.

Processor Board DMC50B

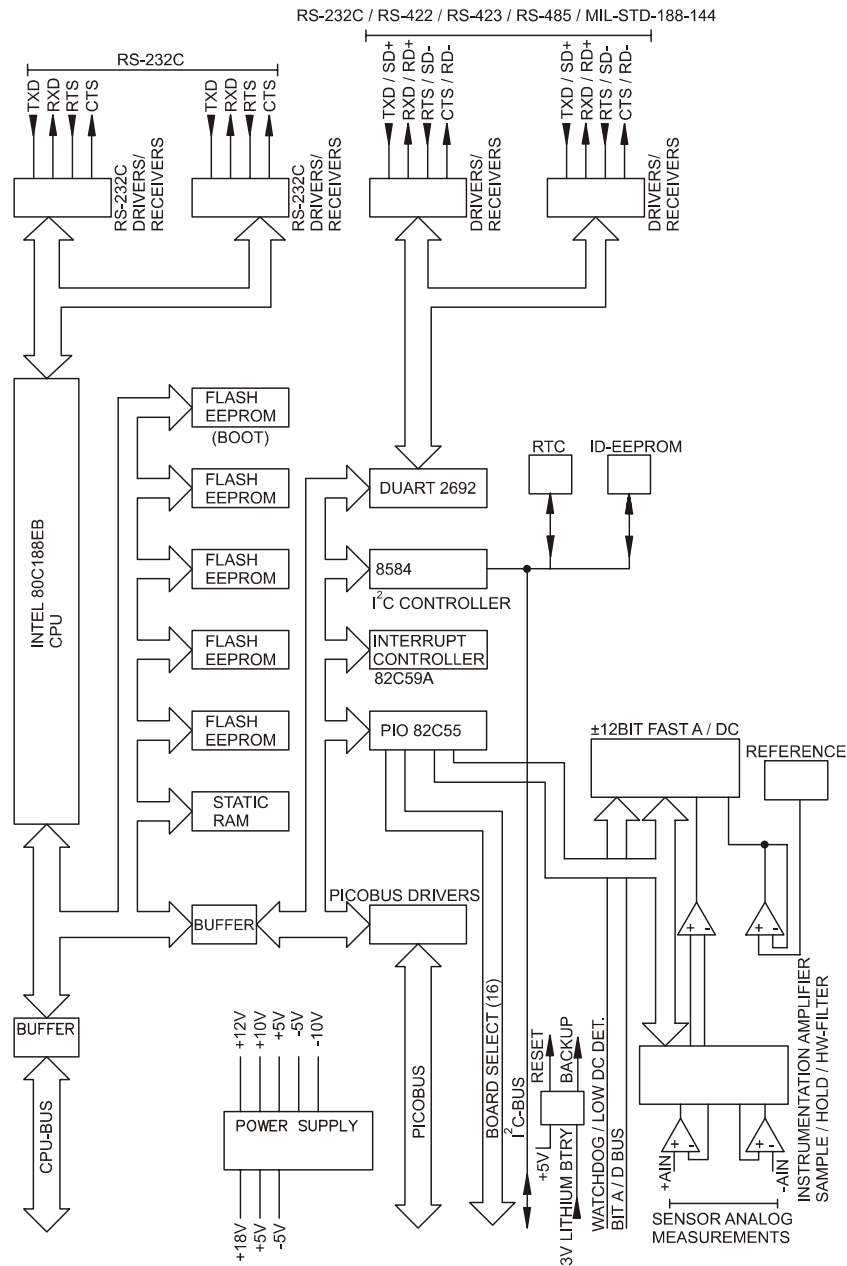

9412-083

Figure 20 DMC50B Block Diagram

The DMC50B Processor Board is the central processing unit of the CT25K. It performs the following functions:

- A-to-D conversion of signals from various internal sensors
- Data processing under a powerful real-time operating system
- Serial communication with external devices

- Internal subassembly control
- Built-in tests of the whole system

Processor

The DMC50B has a fully static 16-bit CMOS processor type 80C188EB. This processor is especially designed for very low power applications and it can be switched by software to its low power idle mode between tasks.

FLASH EEPROM memory is used as storage for the real-time operating system and application specific code files. The SRAM memory stores the variables and serves as an intermediate database.

A Watchdog timer is employed to assure a complete system reset in the event of system malfunction.

A-to-D Converter

Analog data is digitized by a fast ± 12 bit A-to-D Converter located on the DMC50B Board. The converted data is analyzed by the processor and used for various purposes, e.g. internal monitoring.

Serial Communication Ports

A UART (Universal Asynchronous Receiver-Transmitter) controls the serial communication of the system. The CT25K provides two serial communication ports, "MAINTENANCE" (external connector J4, Line/Port A at Processor Board) and "DATA" (external connector J3, Line/Port B at Processor Board). Port B is intended to be used for measurement data communication and Port A for on-site maintenance. When desired, port settings can be changed by corresponding software commands (see section Factory Settings of User Programmable Parameters on page 35 and section User Commands on page 41 for more information). The communication to the DC Converter DPS52 is carried out by I²C Bus, and to the Interface Board DCT52 by I²C Bus and by address and data busses.

The DMC50B Processor Board is built using surface mount technology on both sides, and has no jumpers or IC sockets. The DMC50B is conformal coated for harsh conditions; its temperature range extends from -50 °C to +70 °C.

The DMC50B external communication connectors are located on the front edge of the processor board. The cables can be disconnected for maintenance.

Technical Information

Table 10 Technical Information

Property	Description / Value
Processor Clock Speed	16-Bit 80C188EB, Intel 24 MHz (12 MHz Bus)
Memory FLASH EEPROM STATIC RAM	640 kB 256 kB 1 MB continuous memory addressing
A-to-D Converter Accuracy Speed Gain control Full scale ranges Filtering	± 12 Bit 0.05 % of FSR 200 μ s / Conversion Automatic and programmable ± 2.5 V, ± 250 mV, ± 25 mV, ± 7.5 mV By hardware, software or both
Serial Communication Ports Multistandard Ports	2 configurable ports to comply with: RS-232D, RS-422, RS-423, and RS-485 or MIL-STD-188-114 standards(Data Port P8, Maintenance Port P7)
Data Transfer Rate	110 to 19,200 baud 300 to 9600 baud used in CT25K. Programmable rate, frame, handshake and port standard
Electrostatic Discharge Protection	8 kV per each port pin
Overvoltage protection	Bipolar 30 A (1 ms) TRANSZORBS™
Environmental specifications Temperature Humidity Vibration Electromagnetic compatibility Conducted emissions Conducted susceptibility Conducted susceptibility Radiated emissions Radiated susceptibility	MIL-STD-810D, 501.2 & 502.2-50 °C to +70 °C MIL-STD-810D, 507.20 to 100% RH., not-condensing IEC-68-2-6 Fc 10 - 500 Hz, up to 2.2 g IEC-801-4 MIL-STD-461C, CE03 MIL-STD-461C, CS02 (power leads) IEC-801-4 (fast transient burst) MIL-STD-461, RE02 MIL-STD-461, RS03

See Figure 21 on page 85 and Table 11 on page 85 for DMC50 DIP switch settings.

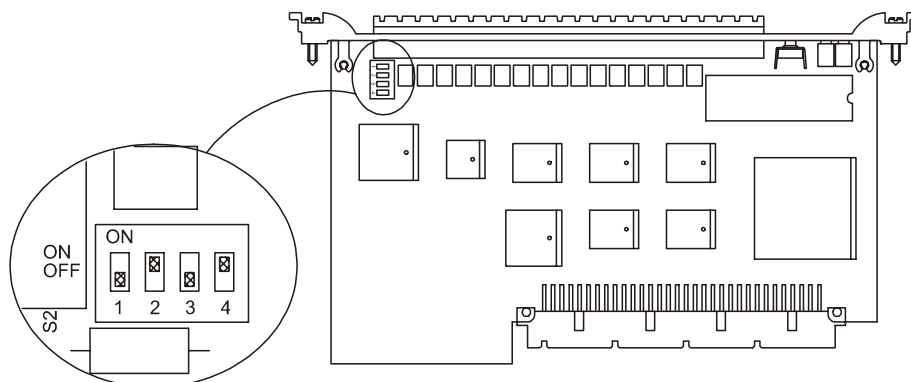

9502-042

Figure 21 DIP Switch Settings of the DMC50

Table 11 DIP Switch Settings of the DMC50

Board	Switch Position	Switch Setting	Function
DMC50	S2 - 1	OFF	Disconnect digital GND from CASE.
	S2 - 2	ON	Enable watchdog timer.
	S2 - 3	OFF	Disable download of operating system.
	S2 - 4	ON	Enable SRAM battery back-up.

DC Converter DPS52

The DPS52 DC Converter is an efficient and self-monitoring power distributor board specially designed for the CT25K. Having five independent switch-mode voltage converters the board is capable of delivering up to 20W. Figure 22 on page 86 shows the block diagram of DC Converter DPS52.

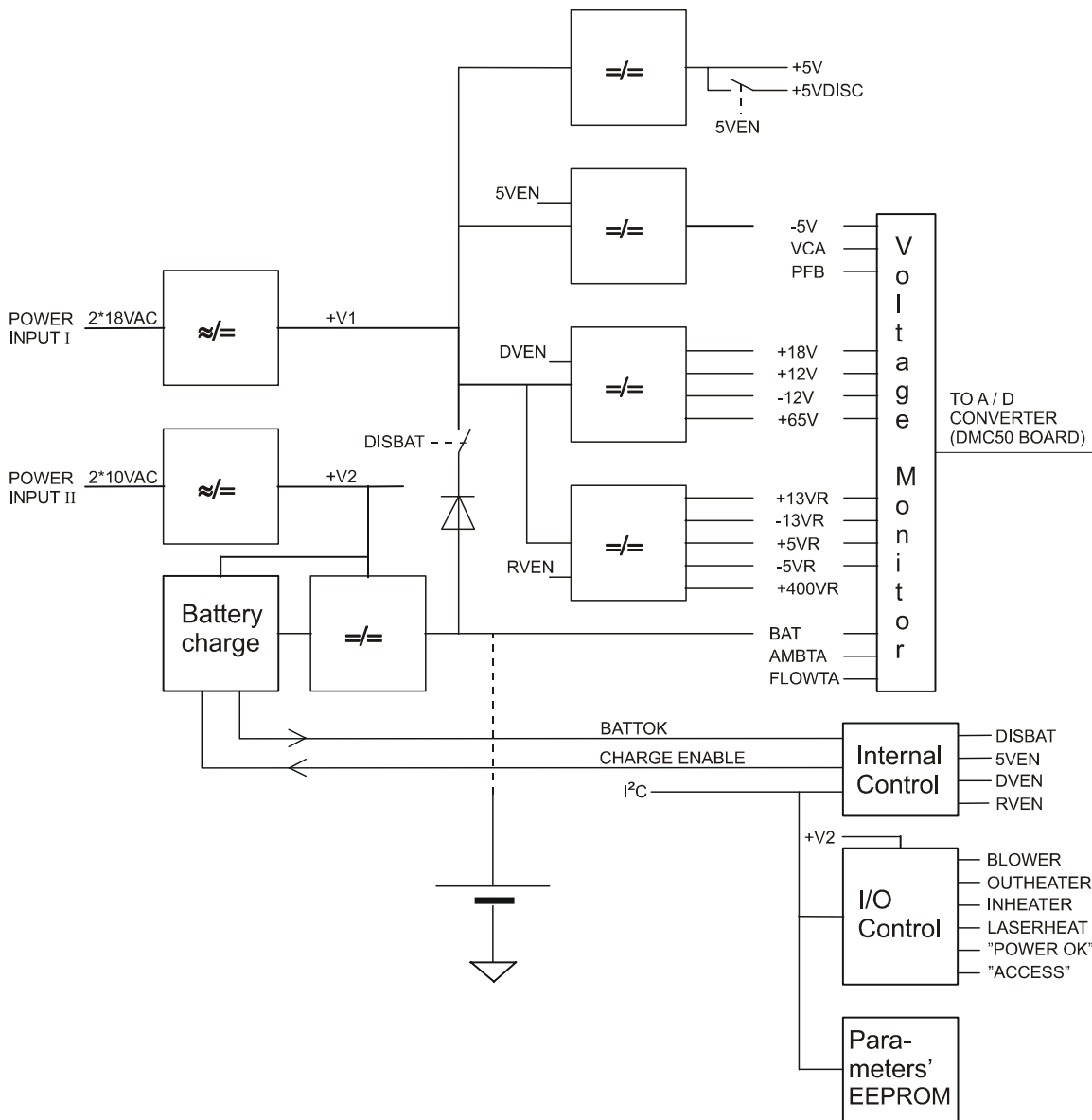

9807-050

Figure 22 DPS52 Block Diagram

Totally 13 voltages are generated within five switching circuits. One step-down switcher is reserved for both +5V and -5V outputs. One flyback switcher produces +18V for CPU, +12V, -12V for optics monitor and 65V for transmitter. Another isolated flyback switcher generates five receiver voltages +13VR, -13VR, +5VR, -5VR and +400VR.

All these voltages are normally supplied by two 18VAC windings. The second supply rectified from two 10VAC windings is reserved for internal battery charger, heating power for transmitter and inheater and outheater control relays.

All voltage and two temperature channel measurements along with several internal and external functions are controlled by a two-wire serial I²C bus.

Identification and other board specific parameters are also saved in EEPROM via this bus.

The internal battery charger keeps the sealed lead acid battery in maximum charge and ready for power back-up. The battery is charged in four phases or states:

- *trickle charge*, while battery voltage is below normal
- *bulk charge*, while battery is charged with maximum current
- *over charge*, while battery voltage is raised over its temperature compensated level
- *float charge*, charge is complete and battery voltage is floating at the temperature compensated level

LED functions

Two LEDs are located in the upper part of the front panel:

- POWER OK LED (D2) is lit when battery circuit is connected and charge is at least in bulk charge state and all voltages are ok.
- ACCESS LED (D1) is lit every two seconds indicating a voltage channel read cycle.

Internal switch settings

The following table describes the internal switch settings of DPS52. For normal operation all switches shall be OFF.

Switch position	Switch setting	Function s/w controlled	Switch setting	Function manual
S1/1	OFF	Not used	ON	Not used
S1/2	OFF	Digital/analog voltages ON	ON	Digital / analog voltages OFF
S1/3	OFF	+/-5V voltages ON	ON	+ / -5V voltages OFF
S1/4	OFF	Receiver voltages OFF	ON	Receiver voltages ON

Specifications

Input voltages:

Power inputs	Voltage ranges
I (AC)	10 ... 22VAC
I (DC)	11.5 ... 30VDC
II (AC)	9 ... 12VAC
II (DC)	9 ... 16VDC

Output voltages:

Signal name	Acceptable range (V)	Nominal current(A)
+5V	5.0 ... 5.8	0.15
-5V	-5.8 ... -5.0	0.05
+5VDISC	5.0 ... 5.8	0.45
+18V	16.0 ... 18.5	0.010
+12V	12.0 ... 13.5	0.1
-12V	-13.5 ... -11.5	0.1
+65V	60 ... 90	0.015
+13VR	12.0 ... 14.0	0.02
-13VR	-14.0 ... -12.0	0.01
+5VR	4.8 ... 5.2	0.06
-5VR	-5.8 ... -4.5	0.07
+400VR	360 ... 425	0.003
VBAT	11.5 ... 16.5	0 ... 0.5

Ceilometer Interface Board DCT52

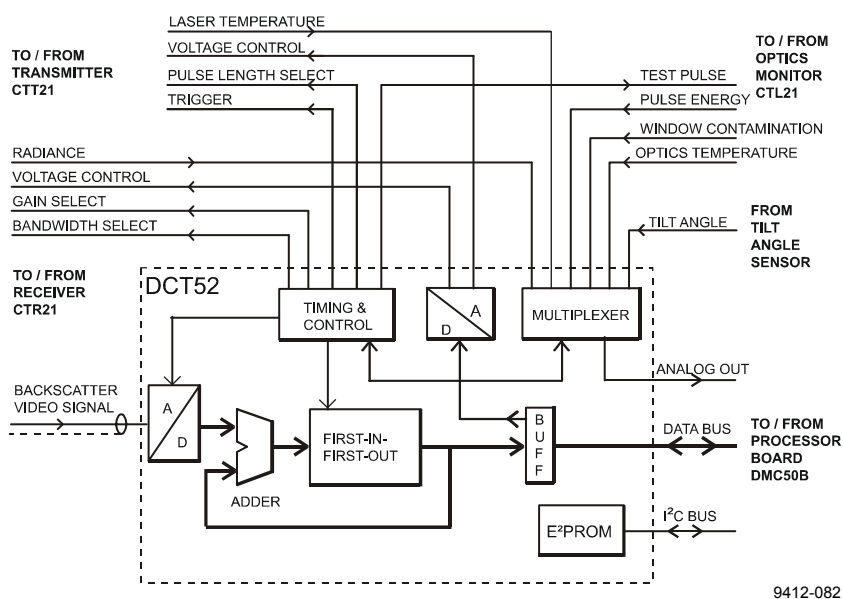

9412-082

Figure 23 DCT52 Block Diagram

The Ceilometer Interface Board DCT52 together with the Processor Board DMC50B are the main components in obtaining the LIDAR backscatter signal, controlling the laser transmitter as well as in real-time processing of the backscatter signal from the receiver as described in section LIDAR Measurement on page 70. Additionally the ceilometer interface board DCT52 contains special circuitry for the timing of all activities and a very fast flash A-to-D Converter. The backscatter signal detected by the photodiode in the receiver is sampled in real-time in this subassembly at the speed equal to that of the light beam in the atmosphere sent from the laser transmitter. All Range Gates are sampled at each laser pulse and digitized by means of the 8-bit flash A-to-D converter. They are stored in a First-In First-Out (FIFO) memory according to the height profile (see Figure 23 above).

For improving the Signal-to-Noise Ratio a large number of laser pulses is utilized and the samples are added to the FIFO memory in digital format. This way, a complete backscatter profile is then available at the end of a complete measurement cycle. The raw values are sent via a data bus directly to the Random Access Memory on the processor board to be algorithmically evaluated. A Digital-to-Analog converter outputs control signals to the laser transmitter and receiver. The D-to-A converter is also controlled through the data bus of the processor board.

A multiplexer contributes to the monitoring of different analog signals from the optics monitor, for temperature measurement of the laser and

for angle measurement of the tilt angle. Controlled by the processor, it connects the analog signals to the A-to-D converter of the processor board.

The timing and control circuit takes care of the triggering and length of the laser pulse and simultaneously for the selection of receiver gain and bandwidth. The system parameters, as they are defined in the configuration and factory settings, are stored in a special EEPROM on the DCT52 board. The data transmission to and from the EEPROM is carried out through an I²C Bus which is independent of the actual Data Bus.

Line and Power Interface Subassembly CTP241

Line AC power is connected to the Line Power and Interface Subassembly CTP241, where it gets transformed down to low-voltage AC for supplying the DC Converter DPS52. Further, the CTP241 contains relays for controlling the Internal Heater (CT25039) and the external Window Conditioner blower motor and airflow heater. Internal heating and window conditioning are under software control via DC Converter DPS52.

WARNING

Line Power and Interface Subassembly CTP241, Internal Heaters' Subassembly CT25039 and Window Conditioner CT2614 or CT2688 contain Line AC voltage, which may be lethal.

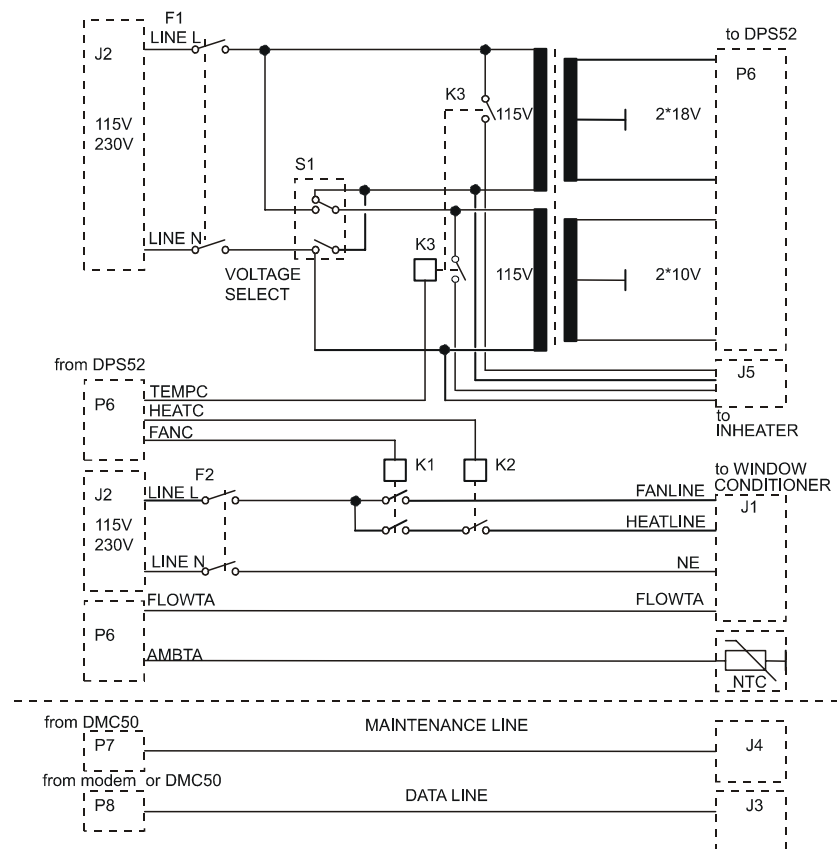

9806-004

Figure 24 CTP241 Wiring

Line voltage selection 100...115 VAC or 220...240 VAC is carried out in the CTP241 by an internal switch, the setting of which is written on the label on the subassembly. This setting also accomplishes the series vs. parallel connection of Internal Heater resistors.

NOTE

For complete power disconnection, both the main switch at CTP241 and the battery switch must be turned to position "OFF". Otherwise the unit is still supplied through the batteries and higher voltage levels inside the unit are possible although the line voltage is disconnected. For normal operation, both switches must be turned to position "ON".

Some of the electronics subassemblies are provided with integral voltage regulators, which internally regulate the actual voltage necessary for operation.

Internal Heaters Subassembly CT25039

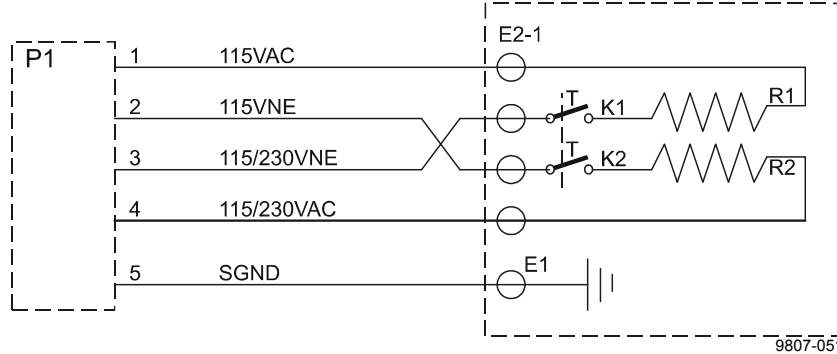

Figure 25 CT25039 Wiring Diagram

The Internal Heaters subassembly CT25039 increases the temperature in the area of the optical subassembly to prevent the lens and the measurement unit window from becoming wet or misty. At the same time it also keeps the whole interior above condensation temperature.

The heating subassembly consists of two power resistors with radiation elements made of aluminium. This provides a good thermal contact with the base plate and transmission of heat to the ambient air. Thermal switches protect the system against overheating.

At 230 V supply voltage the resistors are connected in series by the line voltage selection switch in the subassembly CTP241 and at 115 V supply voltage they are connected in parallel. A relay in the CTP241 switches power on/off under software control via DPS52.

WARNING

The heating resistors can be very hot even after the heating has been switched off! Be cautious when working in the vicinity of the heating!

Specifications:

Maximum power	180W (115VAC +15%, 230VAC +15%)
Max. surface temperature	130 °C
Heating resistors (R1, R2):	
- type	HS100
- resistance	220Ω
- power	100W

Thermal switches (K1, K2):

- switch temperature 95 ... 105 °C
- nominal current 2.5 A
- operating voltage 250 VAC

Tilt Angle Sensor CT3675

The built-in tilt angle sensor CT3675 enables accurate cloud base measurements in a tilted direction. See section Using the Tilt Feature on page 27 for information about alternatives on how to use the tilt feature.

Mounting position in vertically pointed CT25K

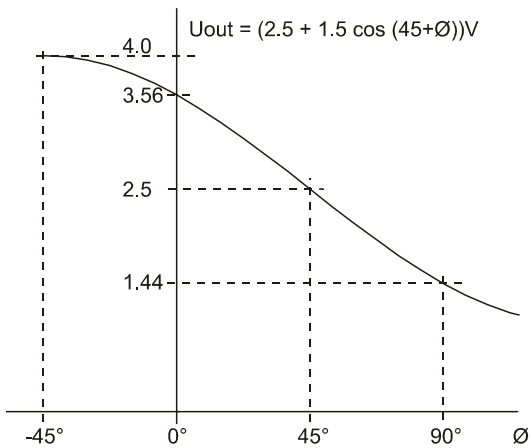
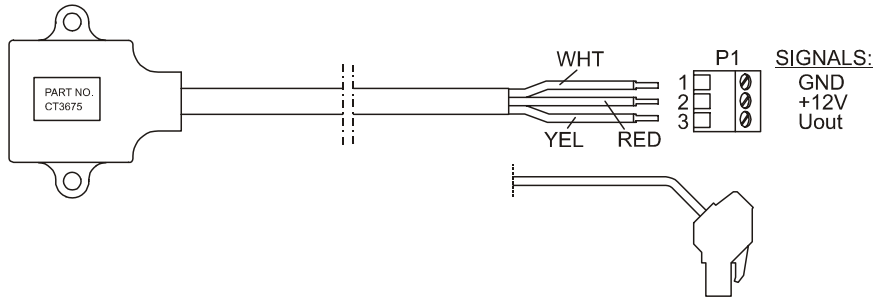
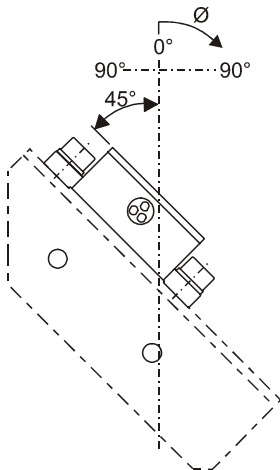

0208-069

Figure 26 CT3675 Tilt Angle Sensor

The tilt angle sensor CT3675 contains a silicon micromechanical acceleration sensor. It measures the Earth's gravitational force as projected on the ceilometer axis. Every change in its position from vertical results in a measurement signal dependent on the angle, which ranges from -15 to +90 degrees from vertical. Internal temperature compensation and linearization circuits provide high stability. The output voltage of the angle sensor is digitized through the processor board A-to-D converter and used for automatic correction calculation, which enables accurate function in a tilted direction. Automatic correction can be disabled with command SET MESSAGE ANGLE_COR OFF. Tilt angle can also be set manually, as described in section Manual Angle Setting on page 61.

Window Conditioner CT2614 / CT2688

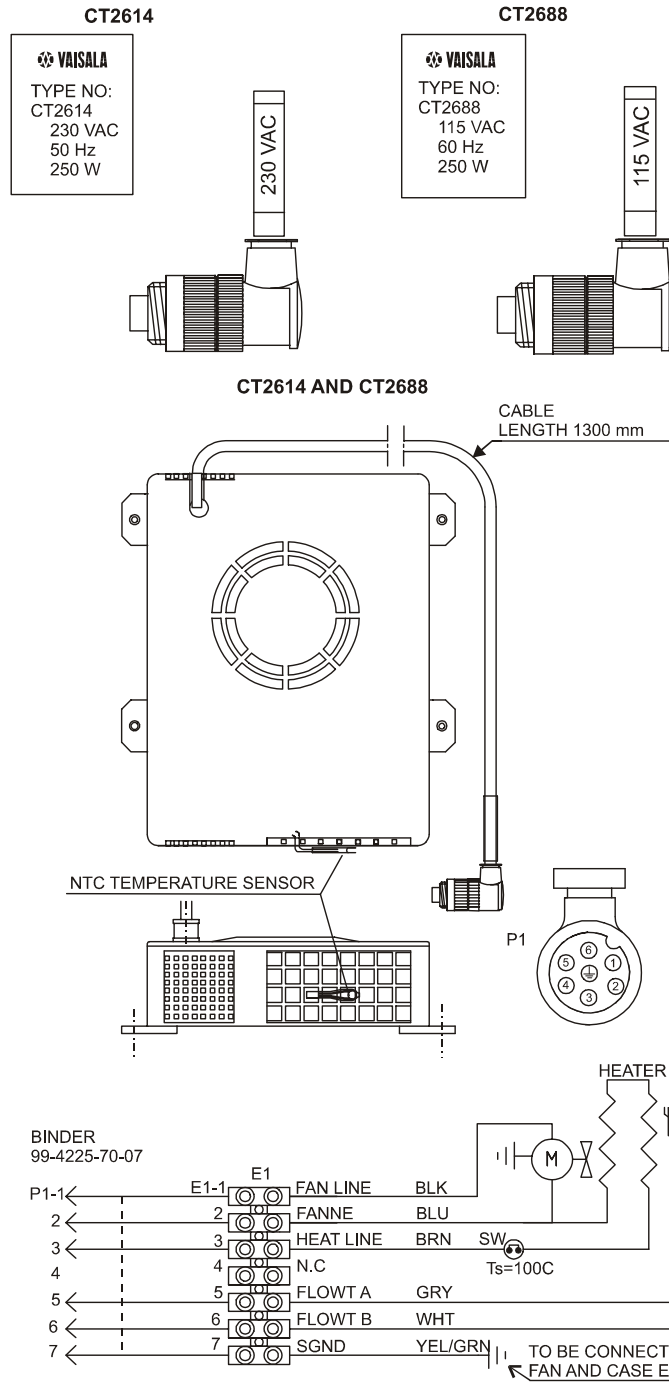

Figure 27 Window Conditioner CT2614 / CT2688

9412-086

The Window Conditioner consists of a blower motor, heating element and an NTC temperature sensor inside an enclosure. The air stream from the blower is directed across the measurement unit window for clearing it from water drops, condensed humidity, snow and particles.

The blower is automatically switched on when contamination or precipitation is detected on the window surface or when the atmospheric measurement indicates that a high risk of precipitation exists. The temperature sensor is used for determining whether the heater should be turned on or not. All of this is done under software control via DPS52 and CTP241.

Because the window of the measuring unit is declined and the blower air is directed from up to down on its surface, water drops and snow are effectively removed.

CAUTION

There are two different window conditioners for the two supply voltages 230 V and 115 V. The plug for the correct connection cable has a marking indicating its nominal voltage.

WARNING

The heating resistors can be very hot even after the heating has been switched off! Be cautious when handling in the vicinity of the heating!

Maintenance Terminal (Option)

A palmtop computer is offered as an optional light-weight maintenance terminal. It is a pocket-size terminal with high resolution display and it includes RAM and FLASHRAM for data storage. Two standard Mignon AA batteries enable operation for about 40 hours.

The palmtop is connected to the CT25K's maintenance line connector J4 with the PC Terminal Cable, CT35198.

Standard port settings are the following:

Baud rate	2400
Data bits	7
Stop bits	1
Parity	Even
Ignore parity	Yes

For further information about the terminal see manuals included in the delivery.

Modem DMX55 (Option)

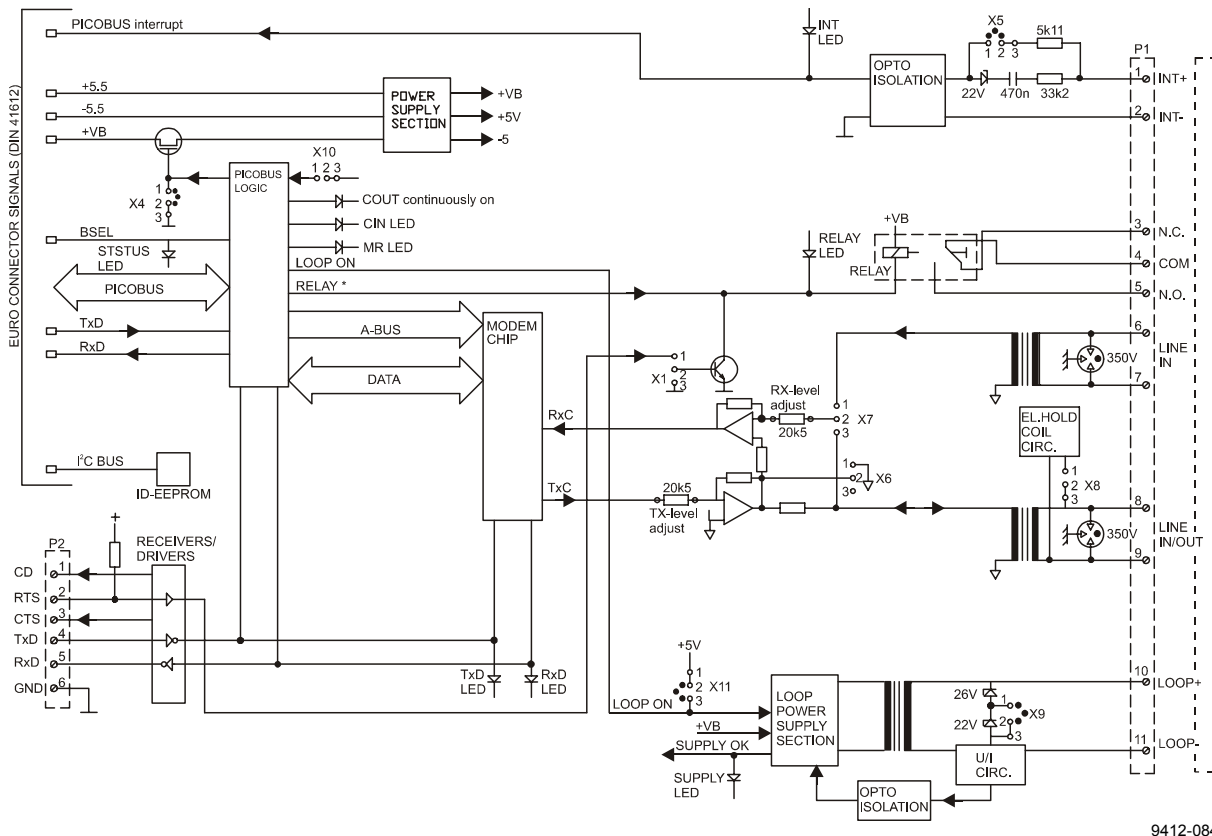

9412-084

Figure 28 DMX55 Block Diagram

Modem DMX55 is a universal modem primarily for fixed point-to-point connections. The operation mode of the modem is set at the factory. In CT25K the supported modes are V.21 and 4-wire V.23.

Safety precautions

Before delivery, the DMX55 modem is tested at the factory for operation and safety. The following safety precautions, however, must be taken into account:

WARNING

Open data lines can have a static charge. Handle the connection wires especially carefully, do not touch them during a thunderstorm. The existing voltages can be dangerous.

LED Indicators

STATUS	Modem operation status, blinking when the processor is active
INT/RI	Interrupt (Ring indicator)
COUT	Transmitting data
CIN	Receiving data
TXD	Transmitted data (data onto modem line)
RXD	Received data (data from modem line)
SUPPLY	Power supply
RELAY	Indicator relay closed
MR	Modem Ready

Connector layout

The internal signal routing of the CT25K connects the modem outputs to connector J3. For further details, refer to the wiring diagrams.

The front panel is provided with the following connections.

6-pin RS-232 Connector (P2)

1	CD	Carrier Detection
2	RTS	Request To Send
3	CTS	Clear To Send
4	TXD	Transmitted Data
5	RXD	Received Data
6	GND	Ground

11-pin Connector (P1)

1	+INT	+Interrupt
2	-INT	-Interrupt
3	N.C.	Normal Closed
4	COM	Relay Common
5	N.O.	Normal Open
6&7	LINE IN	Line In - when separate transmission and reception lines are used (4-wire connection)
8&9	LINE OUT	Line In/Out - when standard 2-wire connection is used or only Line Out at separate wire for transmission and reception
10	+LOOP	Power supply + (not used in CT25K)
11	-LOOP	Power supply - (not used in CT25K)

Modem DMX50 (Option)

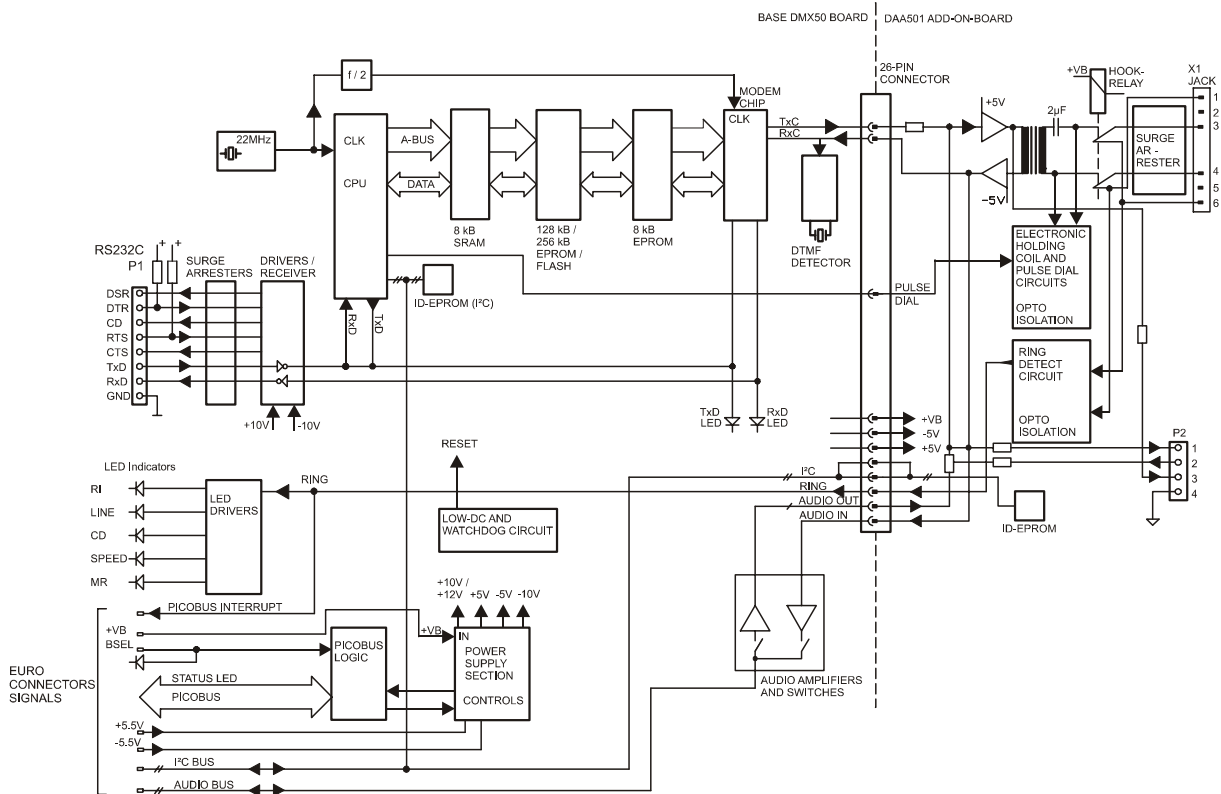

9707-011

Figure 29 DMX50 Block Diagram

Modem DMX50 is a universal modem for fixed or switched point-to-point connections. The operation mode of the modem is set at the factory.

The modem supports standards V.21, V.22, V22 bis and Bell 103 & 212.

Safety precautions

Before delivery, the DMX50 modem is tested at the factory for operation and safety. The following safety precautions, however, must be taken into account:

WARNING

Open data lines can have a static charge. Handle the connection wires especially carefully, do not touch them during a thunderstorm. The existing voltages can be dangerous.

LED Indicators

The DMX50 Modem features the following front panel LED indicators:

STATUS	Modem operation status; blinking when the processor is active
RI	Ring Indicator
LINE	Indicates that the modem is online (off-hook)
CD	Carrier Detection (is ON, when the carrier signal is received)
TXD	Transmitted Data
RXD	Received Data
SPEED	Indicates that modem line speed is 2400 bits/sec (blank when 300 to 1200 bits/sec)
MR	Modem Ready; blinking once per sec when Test Mode is active

Connector layout

DSR	Data Set Ready
DTR	Data Terminal Ready
CD	Carrier Detection
RTS	Request to Send
CTS	Clear to Send
TXD	Transmitted Data
RXD	Received Data
GND	Ground

4-pin connector:

This connector carries telephone line audio signals for special applications, and **SHALL NOT BE CONNECTED** when the DMX50 is to be used over public telephone lines.

6-pin connector:

For line connection. The attached modular telephone cable connector shall be connected to this jack.

Sky Condition Algorithm

General

The CT25K sky condition algorithm uses a time series of ceilometer data to calculate the cloud cover and the heights of different cloud layers. The algorithm is based on so-called Larsson algorithm, developed by Swedish Air Force and Swedish Hydrological Institute (SMHI), but further modified at Vaisala. The sky condition information is included in data messages 6 and 7. The algorithm updates sky condition information every five minutes, based on data gathered during the last 30 minutes. The algorithm reports up to four different cloud layers below 25000 feet.

Sky condition information can be displayed with the DD50 Digital Display.

NOTE

The CTC21 Controller Unit, DR21 Data Recorder and the CT-VIEW software version 1.05 or earlier, can NOT display the sky condition information.

Option code

The sky condition algorithm is included in the 2.01 software. The user activates the algorithm by giving an option code number to the ceilometer. The option code number is based on the DMC50B Processor Board serial number. If the CT25K ceilometer is purchased with the sky condition activated, then this is done at the factory. In case the sky condition option is purchased afterwards, the user can find out the processor board serial number by giving the following commands:

```
CT:open
CEILO>advanced
PASSWORD ACCEPTED !
CEILO>get dmc_sn
DMC SERIAL NO.: 850509 (example)
CEILO>close
```

The processor board serial number is also written on top of the microprocessor circuit, with a letter as the year code. Forward the DMC50B serial number to Vaisala. In response, Vaisala will send the option code needed, for the example below: 48612.

Activation

```
CT:open
CEILO>advanced
PASSWORD ACCEPTED!
CEILO>set option sky_cond on 48612 (example)
Code OK. Sky Condition option activated.
```

Then select the sky condition message type (msg6 or msg7) to be reported:

```
CEILO>set message type msg6
MESSAGE TYPE: 6
CEILO>close
```

NOTE

It is recommended to use a 15 or 30 seconds data acquisition interval with the sky condition option.

Algorithm Overview

The sky condition algorithm collects data for 30 minutes. All cloud heights are rounded to the nearest 50 ft or 10 m and a weight factor is assigned. Each measurement has a total weight of five which is divided between different cloud layers according to Table 12 below.

Table 12 Weight Factors

	1st layer	2st layer	3rd layer
1 layer detected	5	-	-
2 layers detected	3	2	-
3 layers detected	3	1	1

In addition, a weight factor of 2 is applied to the data collected during the last 10 minutes to make the algorithm more responsive to variations in cloudiness.

The weighted cloud hits, counts, are assigned to the cloud height categories or bins (i.e. 0 ... 100 ft, 100 ft ... 200 ft etc.). The bin width increases with the distance according to Table 13 below.

Table 13 Bin Widths

Height	Bin width
0 ... 5000 ft	100 ft
5000 ... 15000 ft	500 ft
15000 ... 25000 ft	1000 ft

The counts are summed starting from the lowest bin. The bins where the sum exceeds 1/33, 3/8, 5/8 and 7/8 of the maximum value are recorded as layer heights. The corresponding cloud amounts for these layers are 1,3,5 and 7 oktas. In addition, the minimum number of counts (hits) for each layer has to be exceeded:

Table 14 Minimum Number of Counts (Hits) for Each Layer

1st layer	17 (3.4 hits)
2nd layer	10 (2 hits)
3rd layer	25 (5 hits)
4th layer	25 (5 hits)

In case the minimum count is not exceeded in the assigned bin, the algorithm seeks three bins upwards and then three bins downwards if one of these bins has the required number of counts. However, if none of the bins contains enough counts, the original bin is used as the layer height.

If the resulted layers are close to each other, it is reasonable to combine them rather than define them as separate layers. If the distance between two cloud layers is less than the minimum distance shown in Table 15 below, the layers are combined. The height of the combined layer is that of the lower layer and the cloud amount of the combined layer is that of the upper layer.

Table 15 Minimum Distance Between Different Cloud Layers

Layer Height	Minimum Distance
< 1 000 ft	100 ft
1 000 ... 2 000	200 ft
2 000 ... 3 000	300 ft
3 000 ... 4 000	400 ft
4 000 ... 5 000	500 ft
5 000 ... 15 000	1 000 ft
15 000 ... 25 000	5 000 ft

Overcast (8 oktas) is reported if all the measurements during the last 30 minutes have a hit. Overcast height is assigned according to the bin where 14/15 of the total count value is exceeded.

However, overcast is not reported if there are "weak hits" during the latest 15 minutes period. A "weak hit" is defined as a backscatter signal which is less than 80% of the reference. The reference value depends on the previous measurements, i.e. it's a kind of sliding average value of signal strength.

Vertical visibility (VV) hits are considered as cloud hits if higher than 1500 feet. The cloud height is defined as $(VV + \text{signal range}) / 2$. Lower VV hits are assigned to a VV register. If the percentage of VV hits in the register during the last 10 minute period exceeds the VLIM parameter value (see Table 7 on page 42), the sky condition algorithm reports VV. The VV height is the average height of VV hits. Otherwise the lower hits are also considered as normal cloud hits, i.e. VV hits are assigned to cloud height categories (bins).

This page intentionally left blank.

CHAPTER 6

MAINTENANCE

This chapter provides information that is needed in basic maintenance of the product.

Periodic Maintenance

Periodic maintenance is normally limited to window cleaning. In addition, Warnings and Alarms should be checked regularly with the maintenance terminal or another terminal or PC with serial connection. See section Status Message "S" on page 55. Proper function of the Window Conditioner air blower, the only mechanically moving part, should also be checked.

Alarms and Warnings

The data message has to be checked for alarms and warnings at regular intervals. At the second character of line two there is Warning and Alarm information indicating the present status of the device as follows:

0	Self-check OK
W	At least one Warning active, no Alarms
A	At least one Alarm active

In case there is an active alarm or warning, more information is given at the end of the second line as a binary code indicating the cause. The status message gives detailed information about the failure (see section Data Messages on page 45).

Repair and service must be done according to instructions in Chapter 7, Troubleshooting, on page 111 and Chapter 8, Repair, on page 121.

Window Cleaning

The lens and window should always be clean of any dirt or particles during operation. Data messages include a warning if the window is contaminated.

After the system has detected the contamination it starts the blower, which removes contamination caused by precipitation etc.

- If the "Window Contaminated" warning does not disappear after a while the window has to be cleaned.
- To clean the window first flush it with clean water to remove coarse grains. During this operation, the enclosure door should be closed. Clean the window with a soft lint-free cloth moistened with a mild detergent. Be careful not to scratch the window surface.

The condition of the Window Conditioner air blower can be checked with the maintenance terminal connected. Give the commands:

SET CONTROL BLOWER ON

SET CONTROL BLOWER OFF

In case of malfunction the Window Conditioner has to be replaced.

The door of the measurement unit utilizes an electrically conductive rubber gasket to suppress electromagnetic radiation. When the door is opened, check that the gasket and the opposite contact surface are clean. Use wet cloth for cleaning if necessary.

Battery Check

Check the battery condition annually. If any signs of aging is observed like bulging battery case, white powder or residue near the battery vent, leaking electrolyte, corroded terminals etc. replace the battery. Lead acid batteries may age in 3 to 5 years time and result in a rupture and loss of electrolyte.

NOTE	When disposing of old batteries, be sure to do so in accordance with local environmental regulations.
-------------	---

NOTE

In freezing temperatures there is a danger of battery rupture if the battery is completely discharged. Do not store empty batteries in freezing temperatures. Replace the battery if signs of mechanical rupture are observed.

Storage

Have caps on all external connectors if stored unpacked for extended times in an unconditioned area. Also maintain a dust cover on the window during long periods of storage.

The container is suggested to be saved for future transport use. When replacing, the equipment shall be placed and padded in the same way as when initially received.

This page intentionally left blank.

CHAPTER 7

TROUBLESHOOTING

This chapter describes common problems, their probable causes and remedies, and contact information.

Normal Operation

Equipment

To establish a service connection to the CT25K you need to have a maintenance terminal which can be a palmtop computer with an RS-232 Interface or a PC with serial interface, PC Terminal Cable CT35198, and any terminal program. CT-VIEW software can be used for this purpose. Instead of maintenance connector J4 the service connection can also be made directly to the front panel of DMC50B processor board, for example with RS-cable 16385ZZ. On the DMC50B front panel the data port is marked as P8 and maintenance port as P7. Also, if you perform the operation check indoors, you need to have an Optical Termination Hood (CT25184) which absorbs the laser light that otherwise would reflect from the ceiling and possibly saturate the receiver.

Instructions

To check the normal operation of the CT25K do the following steps:

1. Clean the window carefully with a soft lint-free cloth moistened with mild detergent. Be careful not to scratch the window surface.

2. If you are indoors, put the Optical termination hood (black hat) on the ceilometer window. From the ceilometers point of view this corresponds to a clear, nighttime sky.
3. Connect the maintenance terminal to the maintenance port at the bottom of the CT25K. Turn on both the CT25K and the maintenance terminal. If you are using the palmtop or the CT-VIEW program for the first time, do the necessary installation according to the corresponding User's Guide instructions.
4. Check that the operation of the ceilometer starts normally, as follows: After power-up routines, the MEAS LED D4 (LED = Light Emitting Diode) on the DCT52 board periodically lights 12 seconds and the cycle is repeated according to the programmed data acquisition interval. In the DC Converter DPS52 Board LED D1 should be blinking yellow and LED D2 should be stable green. Also, in the Processor board LED STATUS should be blinking at a 1 second interval.
5. Get the status message as follows: Press ENTER on the maintenance terminal (PC) keyboard and a CT: prompt should appear. Give the command OPEN and press enter.

CT> OPEN ↵

A CEILO> prompt should appear. Give command GET STATUS and press enter.

CEILO> GET STATUS ↵

Status format example :

```
VOLTAGES (UNIT 0.1V)
P12 125 M12 -126 P5G 54 M5G -54 VCA 225
P13 128 M13 -124 P5R 50 M5R -50 BAT* 098
P18 178 PHV 2306 PFB 17 P65 674 CHA 144
```

```
RECEIVER          TRANSMITTER
GAIN H            PLEN L
BAND N            PQTY 64K
SAMP 10MHz        OUT 1416mV
SENS OK           SENS 101%
```

```
TEMPERATURES      ENVIRONMENT
BLOWER            +20C WINDOW      210 mV 101%
CPU               +34C RADIANCE      +60 mV
LASER             +29C ANGLE        +3 DEG
LENS              +34C HUMIDITY     NONE
OUTSIDE           +23C
```

INHEATER ON OUTHEATER OFF BLOWER OFF

NOTE

If there are variables showing xxx-values in the status message, the power up routines are not finished. Wait for a while and ask for the status again.

6. Check the status message.

All the VOLTAGES, RECEIVER and TRANSMITTER values are within predefined limits if no asterisks (*) appear. An asterisk in front of a variable indicates that an alarm or warning limit of that variable is exceeded. In the status example above, the battery voltage is too low.

Check the TEMPERATURES. The OUTSIDE temperature should be close to the environment temperature. The CPU, LASER and LENS temperatures are typically 10-15 degrees higher than the OUTSIDE temperature.

Compare the ANGLE. If the ceilometer is in a vertical position (i.e. pointing upwards) the ANGLE should be -2 ... +2 degrees.

7. Check the message line operation.

Give the commands:

SET MESSAGE PORT MAINTENANCE ↵

CLOSE ↵

The following lines should appear (example: Msg 1):

☎CTA2010☺ ↵

00 // // // // // 00000200 ↵

☺ ↵

Reading instructions for the second line, identical in all messages:

Message	0	0	////	////	////	FEDCBA98 ↵
Position	1	2	3	4	5	6

- Position 1: 0 indicates that no cloud layers are detected.
- Position 2: 0 indicates that there are no warnings or alarms, W indicates a warning and A indicates an alarm.
- Position 3 ... 5:: /////
Position 6: Alarm (A), Warning (W), and internal status information. Each character is a hexadecimal representation of four bits, altogether 32 bits, with the following breakdown. Interpretation as follows:
- F: (8000 0000) Laser temperature shut-off (A)
 - (4000 0000) Laser failure (A)
 - (2000 0000) Receiver failure (A)
 - (1000 0000) Voltage failure (A)
 - E: (0800 0000) (spare) (A)
 - (0400 0000) (spare) (A)
 - (0200 0000) (spare) (A)
 - (0100 0000) (spare) (A)
 - D: (0080 0000) Window contaminated (W)
 - (0040 0000) Battery low (W)
 - (0020 0000) Laser power low (W)
 - (0010 0000) Laser temperature high or low (W)
 - C: (0008 0000) Internal temperature high or low (W)
 - (0004 0000) Voltage high or low (W)
 - (0002 0000) Relative Humidity is > 85 %
(option) (W)
 - (0001 0000) Receiver cross-talk compensation
poor (W)
 - B: (0000 8000) Blower suspect
 - (0000 4000) (spare) (W)
 - (0000 2000) (spare) (W)
 - (0000 1000) (spare) (W)
 - A: (0000 0800) Blower is ON
 - (0000 0400) Blower heater is ON
 - (0000 0200) Internal heater is ON
 - (0000 0100) Units are METERS if ON, else FEET
 - 9: (0000 0080) Polling mode is ON
 - (0000 0040) Working from battery
 - (0000 0020) Single sequence mode is ON
 - (0000 0010) Manual settings are effective
 - 8: (0000 0008) Tilt angle is > 45 degrees
 - (0000 0004) High background radiance
 - (0000 0002) Manual blower control
 - (0000 0001) (spare)

For example, if the battery voltage is too low, a warning is given and the second line appears as

```
OW // // // // 00400200
```

In this example the internal heater is also on.

Check the operation of the window conditioner.

8. Wait until the 15 minutes start-up blowing has passed. Place a piece of white paper on the ceilometer window. Within one minute the blower should start. Remove the paper. Within one minute the blower should stop.
9. If there are clouds present, compare the ceilometer measurement with the qualified weather observer's height approximation.
10. In case there are no clouds present and if the site is suitable, do a hard target test. Turn the measurement unit 90 degrees and aim on a fixed target (wall, forest front, etc.).

NOTE

The minimum distance to a hard target should be 300 meters (1,000 ft). The backscatter signal from a hard target is very strong compared to the signal from a cloud. The receiver may saturate if the distance is too short.

CAUTION

When tilting the unit, make sure that nobody is watching it with binoculars or other magnifying optics.

Disable the automatic angle correction by giving commands :

```
CT> OPEN
```

```
CEILO>SET MESSAGE ANGLE_COR OFF
```

```
CEILO>CLOSE
```

Compare ceilometer's distance reading to a reference measurement.

Troubleshooting

The purpose of this troubleshooting is to locate the problem. If a damage is suspected in a subassembly or a board, replace it with a

spare part and send the defective part to Vaisala for repair / replacement.

NOTE

Replacements have to be done according to instructions given in the Instructions for Replacement of Parts in section 8 and are allowed for trained personnel only. As a principle, customer made repairs are restricted to replacement of subassemblies only.

Warnings

Table 16 Warnings

Status Message Info	Reason	Instructions
Window contaminated warning (Appears from time to time and lasts < 5 min).	Usually rain drops on the window.	The blower will clean the window. If clouds are detected, the height information is correct. If no clouds are detected, it is possible that high clouds are missed.
Window contaminated warning. (Continuous)	Bird droppings, leaves, dust etc. have contaminated the window.	Clean the window.
Battery low warning	The unit has been powered too long using the backup battery.	Connect the line voltage or replace the battery.
	Recharging of the battery fails.	If the battery is old, replace it. If the battery is OK, check the operation of the DPS52 DC Converter.
Laser power low warning.	Laser diode too old.	Replace Transmitter CTT21.
	Optics monitor CTL21 failure.	If you have replaced the Transmitter CTT21 and the warning did not disappear, replace the CTL21 Optics Monitor.
Laser temperature high or low warning.	Environment temperature too high.	If the environment temperature is above 60°C do not operate the ceilometer.
		Direct sunlight can burn the laser diode. Use Tropics window or turn the ceilometer away.
	Environment temperature too low.	If the environment temperature is below -50°C the heating capacity is not sufficient. Do not operate the ceilometer.
	Ceilometer is battery operated.	If the ceilometer is battery operated, all the heating functions are disabled and the unit can be operated only in temperatures above -10°C. Connect the line voltage and wait for a while.

Status Message Info	Reason	Instructions
	Heating fails.	Check the Transmitter Board (CTT21) where the heating circuitry is located. Check that the DC Converter (DPS52) supplies the current for the heating.
Internal temperature high or low warning.	Environment temperature above 60°C or below -50°C.	Do not operate the ceilometer.
Voltage high or low warning.	Line voltage is not OK.	Check that the line voltage is present and correct.
	DC Converter board DPS52 is damaged.	Check the status message. If there is an asterisk (*), the voltage exceeds the limits.
Relative humidity > 85 % warning (option).	Water has been condensed inside the ceilometer. Leakage in the enclosure or leakage in the door.	Take the ceilometer inside, open the maintenance door and let it dry in a warm air conditioned place. Condensed water on optical surface may disturb the measurement. There is a danger for short circuits.
Receiver optical cross-talk compensation poor warning.	Obstacle or dirt on the lens or on the window.	Check the optical surfaces. Clean, if contaminated.
	The compensation fiber is damaged.	When sky is clear but the GAIN is low and the PLEN is short, the fiber is most likely broken. Remove the optical fiber carefully. Place the other end near a light source. If the light is dim at the other end of the fiber, the fiber is damaged. Replace it.
	The compensation fiber is misplaced.	Do compensation adjustment following the replacement instructions (see Chapter 8, Repair, on page 121).
Blower suspect warning.	Cable is not connected.	Check that the blower cable is connected.
	Window conditioner circuit braker F2 is not ON.	Check that the window conditioner circuit braker F2 is ON.
	Line voltage level is not correct.	Check that the line voltage is present and correct.
	Blower is stuck.	Check if visible obstacles disable the blower operation.
	Blower is damaged.	Replace the blower.

Alarms

Table 17 Alarms

Problem	Reason	Instructions
Laser temperature shut-off.	Direct sunlight.	Direct sunlight can burn the laser diode. Use Tropics window or turn the ceilometer away.
	Environment temperature too high.	Do not operate the ceilometer.
Laser failure.	Laser is worn out or damaged.	Check the operation of laser transmitter CTT21 and its cable connections.
	Laser does not get electrical power.	Check from the status message if there is an asterisk (*) in front of any voltage value indicating malfunction in the DPS52 DC Converter board.
	Outgoing laser power failure.	Check that the Optics Monitor CTL21 board is not misplaced or damaged.
	INLASER setting does not function.	Check the operation of the Ceilometer Interface Board DCT51.
Receiver failure.	Loose cable connection.	Check that the cables from the receiver CTR21 and from the Optics monitor CTL21 are undamaged and connected correctly.
	Receiver test not operating.	Check that the Optics Monitor CTL21 board is not misplaced or damaged.
Voltage failure.	DC Converter board DPS52 is damaged.	Check the status message. If there is an asterisk (*), the voltage exceeds the limits.

Miscellaneous

Table 18 Miscellaneous

Problem	Reason	Instructions
DPS52 Power OK LED (D2) is not lit.	Power is not connected.	Check that both the main and the battery switches are in ON position.
		Check the presence and correctness of the line voltage. Check also that the battery is OK.
	Loose cable onnection.	Check the cable connections.
DCT52 LED D4 is not lit.	DMC50B or DCT52 is damaged.	Check from the status message if the voltages are present and correct. If yes, suspect a damage in the DMC50B or DCT52 board.

Problem	Reason	Instructions
The period of LED D4 in the DCT52 board is much shorter than the normal 15 sec. measurement interval.	Self-check not finished in 5 minutes.	Unit is unable to finish the compensation adjustment. If the unit is operated indoors use the optical termination hood. Other causes may be a dirty window or a broken compensation fiber.
Data message is missing.	Dialogue not operating.	Check the cable connections. Open the terminal program and press the ENTER key a few times. The ceilometer should respond with CT: prompt.
	Wrong communication parameters.	Check the communication parameters (number of bits, parity, etc.).
	Wrong data port.	Open the terminal program and first give OPEN command and then GET MESSAGE command. Check that the PORT is set to DATA.
	Operation mode standby.	Open the terminal program and first give OPEN command and then GET OPER_MODE command. Check that the OPERATION MODE is CONTINUOUS.
Cloud detection missing.	Alarm or warning in the data message.	Open the terminal program and first give OPEN command and then GET STATUS command. Check that there are no alarms or warnings.
	CT25K parameters are not correct.	Compare parameters with the parameters of the delivery documents.
Reduced capacity to see high clouds.	Broken or misplaced compensation fiber.	When sky is clear but GAIN is low and PLEN is short, the fiber is most likely broken. Remove the optical fiber carefully. Place the other end near a light source. If the light is dim at the other end of the fiber, the fiber is damaged. Replace it.

Failure Diagnosis

In case of malfunction do the following:

1. Check the cable connections (see section see section Cable Connections on page 28).
2. Check the presence and correctness of the line voltage.
3. Check the operation states of the LEDs in the unit (see section Startup Procedure on page 32).

4. At the data line, check that the connection and the configuration is correct (see sections Output Interface on page 152 and Cable Connections on page 28).
5. Switch on the unit (see section Startup Procedure on page 32, all switches to position ON).
6. Check the data messages by using the maintenance terminal (see section Data Messages on page 45).
7. Check the adjustment of the unit (see section Prevailing Parameter Settings on page 59).
8. Check the status message (see section Data Messages on page 45).

The diagnosis is made on the basis of the information given in the status message (see section Troubleshooting on page 115).

NOTE

Service has to be done according to instructions given in this manual and are allowed for trained personnel only. As a principle, customer made repairs are restricted to replacement of subassemblies only.

CHAPTER 8

REPAIR

General

Replacing a subassembly comes into question when there is reason to suspect that malfunction of the Ceilometer CT25K is caused by a fault in that subassembly.

CAUTION

Servicing the equipment must be performed by qualified personnel.

Writing Conventions Used

Replacement of a subassembly may require parameter settings that are specified in the description of that subassembly. The commands are expressed in this manual as follows:

COMMAND↵

where

COMMAND = Command given by the user, can consist of several command words (and parameters) e.g. GET

STATUS↵

↵ = Symbolizes pressing the ENTER key.

NOTE

All words of the commands shall be separated from each other by a space character i.e. by pressing the space bar.

Every user command must be ended by pressing the ENTER key, illustrated in this manual by ↵.

Start-Up Procedure for Replacement (All Parts)

Replacement can be done outdoors even in the presence of light precipitation but in this case take care that the removed subassembly remains dry and no water gets into the interior of the Ceilometer CT25K. However, if adjustment is needed after replacement then that must be done in clear weather conditions or indoors using the Optical termination hood (CT25184).

Before you start to remove or replace parts do as follows:

1. Open the enclosure door of the Ceilometer.
2. Turn the Circuit Breakers F1 and F2 to OFF position.
3. Turn the Battery Switch OFF.
4. Detach all cables from the external connectors J2 ... J4.

Tilting the Ceilometer unit slightly backwards gives better access to the interior. To tilt the unit, loosen the two screws of the pedestal first. Tilting backwards must not be done in rainy weather.

Clean the window by flushing it with water to remove coarse grains. During this operation, the enclosure door should be closed. Use a soft lint-free cloth moistened with mild detergent. Be careful not to scratch the window surfaces.

Check also the condition of the shield and clean it if necessary.

NOTE

Outdoor adjustments should be done in clear weather conditions (no precipitation, no fog present and no clouds below 1,000ft). Also the window must be clean. If the ceilometer is serviced indoors, or outdoors with fog or clouds below 1,000 ft present, then an **Optical Termination Hood (CT25184)** must be used to prevent the receiver from saturating from the backscatter signal. Optical termination hoods can be purchased from Vaisala .

Refer to Figure 30 below for cable connections of the subassemblies.

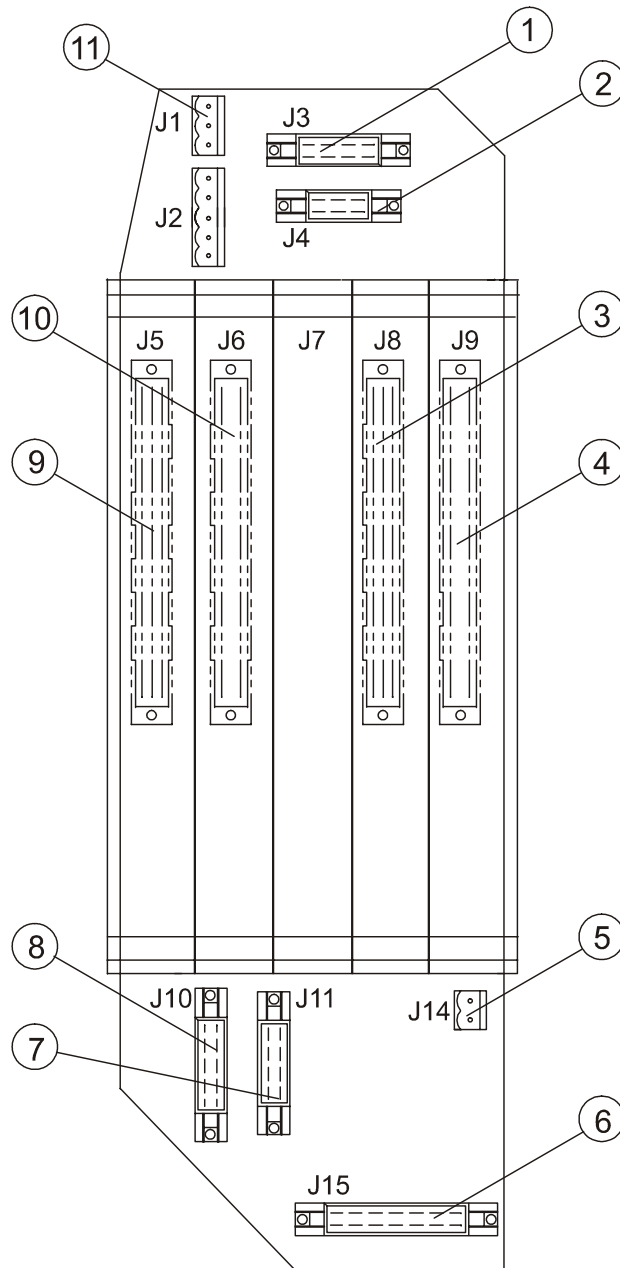

0208-068

Figure 30 Board Connectors of the DMF51 Board Frame

The following numbers refer to Figure 30 above:

- 1 = J3 Optics monitor
- 2 = J4 Local display
- 3 = DMC50B Processor board
- 4 = DPS52 DC converter board

The following numbers refer to Figure 30 above:

- 5 = J14 12V local battery
- 6 = J15 AC power interface
- 7 = J11 Receiver
- 8 = J10 Transmitter
- 9 = DCT52 Ceilometr interface board
- 10 = Modem board (optional)
- 11 = J1 Tilt angle sensor CT3675

Transmitter CTT21

Removal

WARNING

The laser diode at Laser Transmitter CTT21 emits invisible laser power which is harmful to the eye if viewed at short distance. Never remove the transmitter from its normal position without first switching both the line and the battery power off and detaching the ribbon cable of Laser Transmitter CTT21 from the Board Frame DMF51.

When there is reason to suspect malfunction of the Transmitter, turn the power off (Note Paragraph 8.3 Start-up procedure) and do as follows:

1. Detach the ribbon cable connector of the transmitter from connector J10 at the DMF51 Board Frame by pressing the latches apart. Refer to Figure 30 on page 123.
2. Loosen the attachment ring (Figure 31 on page 125) using a 2.5 mm Hexagon Key as a lever; there are holes in the attachment ring for that purpose. If the Transmitter begins to move along, stop it by hand from rotating.

NOTE

The laser diode has been centered at the factory - do not apply force to the Transmitter because it may disturb the centering. Take the Transmitter in your hand.

3. Deliver the entire Transmitter to Vaisala.

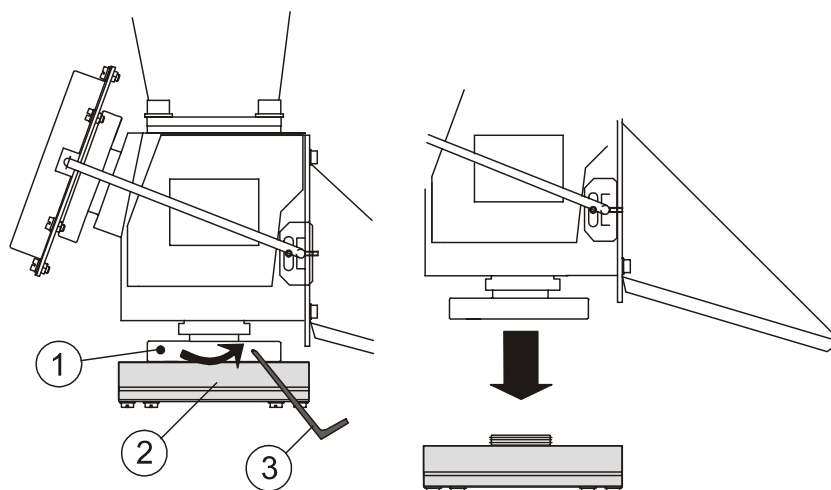

Figure 31 Removing the Laser Transmitter

The following numbers refer to Figure 31 above:

- 1 = Attachment ring
- 2 = CTT21 Laser transmitter
- 3 = Unscrew the attachment ring using 2.5 mm hex key as a lever (no screw in the hole)

Replacement

To replace a Laser Transmitter CTT21 (See section Startup Procedure on page 32.):

1. Take the Transmitter CTT21 in your hand and set it in place. Notice the right position, the ribbon cable comes out from the back side. Rotate the attachment ring (Figure 31 above) by hand and tighten it using a 2.5 mm hexagon key as a lever. If the transmitter begins to move along, carefully stop it by hand from rotating.

NOTE

Do not apply force to the transmitter itself because it may disturb the centering.

Check that the transmitter is now in the correct position, that is, the sides of the transmitter case are approx. parallel with the edges of the lower part of the Optical Subassembly. If this is not the case, loosen the attachment ring first, then correct the transmitter position and fasten as described above.

2. Attach the ribbon cable connector to the DMF51 Board Frame to connector J10. Refer to Figure 30 on page 123.
3. Connect the Power Cable and the Maintenance Terminal. Turn the power on.
4. If the transmitter has been replaced by a new one, do the following:
 - a. Open the command set by first typing OPEN↵ at the command prompt and then typing the password ADVANCED↵.
 - b. Interrupt autoadjustments with the command STOP↵

Then give the following commands

```
SET DATA_ACQ AUTOADJ OFF↵
```

Sets the autoadjustments off.

```
SET PORT TIMEOUT 20↵
```

Sets the timeout of the dialog to 20 minutes.

```
SET DATA_ACQ INTERVAL 15↵
```

Sets interval for measurement and message sending to 15 seconds.

- c. First check the prevailing settings with the command GET FACTORY↵

The value of INLASER tells the prevailing factory setting of the Transmitter Calibration Factor.

- d. Note the Calibration Factor of the transmitter (written on the subassembly). If the transmitter has been replaced and the Calibration Factor differs from the prevailing factory setting, give the new Calibration Factor value (= new factory setting) with the command:

```
SET FACTORY INLASER↵
```

and type the new Calibration Factor value ↵.

- e. Set the laser power into effect with the command SET DATA_ACQ TRANSMIT POWER_OF_P↵

and type the new value (= Calibration Factor) ↵. (The same Calibration Factor value as in step d).

- f. Wait until a few measurement cycles have been completed, and the new value has been updated in the status message. Give the command

GET STATUS↵

- g. Check from the status message under the title Transmitter that the IN value of the transmitter in question equals the Calibration Factor.

- h. Check from the status message under the title Transmitter the OUT value which tells you the measured optical power, and write it down. Give the command

SET FACTORY OUTLASER↵

and type the recent OUT value↵.

Wait again until a few measurement cycles have been completed, and the new value has been updated in the status message. Give the command

GET STATUS↵

Check from the status message that the Transmitter SENS percentage is in the range 99% ... 101%. This tells you the present measured OUT value compared to the factory setting.

- i. Check further from the status message under the title Environment the WINDOW value and write it down. Set this value as a reference value of a clean window with the command:

SET FACTORY WIN_CLEAN↵

and enter the recent WINDOW value↵.

Wait again until a few measurement cycles have been completed, and the new value has been updated in the status message. Give the command

GET STATUS↵

Check from the status message that the WINDOW value percentage is in the range 97% ... 103%. This tells you the

present measured WINDOW contamination value compared to the factory setting.

- j. Then adjust the Internal Crosstalk Compensation according to section Compensation Adjustments below.
5. Turn the power off. Then start the Ceilometer again and verify that it is operating properly.

Compensation Adjustments

Internal crosstalk compensation must be adjusted after a transmitter, a receiver or an optics monitor has been replaced or if the compensation fiber has been replaced. Adjustment should be done in clear weather conditions or indoors using the Optical termination hood (CT25184).

After the command set has been opened using the password ADVANCED give the following commands:

1. To interrupt autoadjustments give the command
STOP ↵

Then give the following commands:

```
SET DATA_ACQ AUTOADJ OFF ↵
```

```
SET PORT TIMEOUT 20 ↵
```

which set the autoadjustments off and the timeout of the dialog to 20 minutes.

2. Give values for fine and coarse compensation as follows:
SET DATA_ACQ COMP COARSE 13 ↵

```
SET DATA_ACQ COMP FINE 125 ↵
```

3. Wait until a few measurement cycles have been completed. To monitor the quality of the compensation give the command
SET OPER_MODE COMP_MONIT ↵

which gives you a graphical output as shown in Figure 33 on page 131.

In case the graph differs from the graph shown in Figure 33 on page 131, you have to adjust the Compensation light level manually. This is done via Screw B (Compensation light level

adjustment) on the receiver CTR21 using a 1.5 mm hexagon key (See Figure 32 below). Later revisions of the receiver have a 5.5 mm locking nut on screw B; if so, loosen it first. Turn the screw either clockwise or anticlockwise to optimize the form of the graph. If the peak of the graph broadens, change the direction.

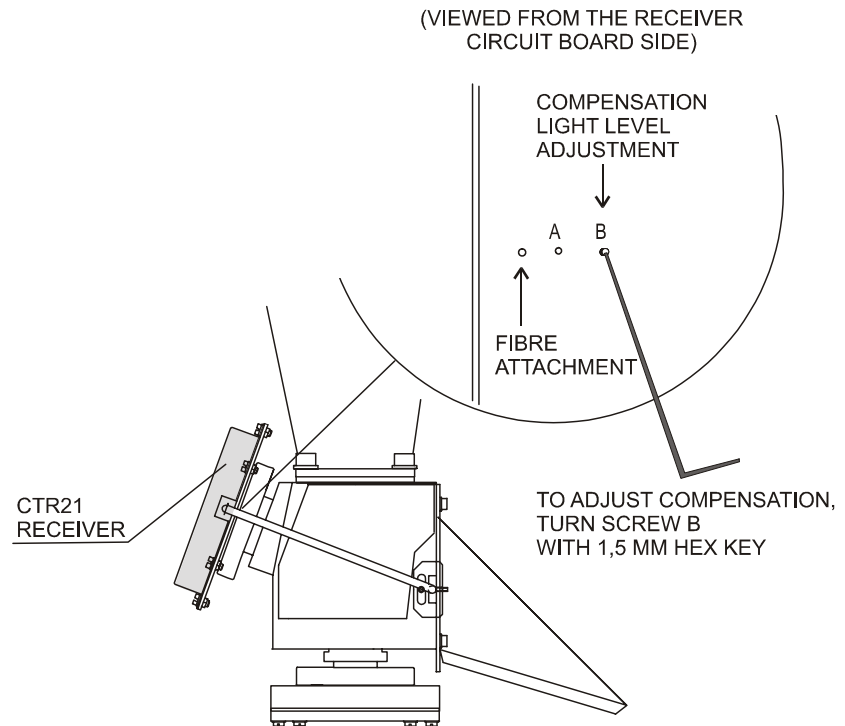

9512-014

Figure 32 Adjusting the Compensation

Adjusting should not require more than a couple of turns. The screw should not move too easily after the adjustment has been completed. If a locking nut is in place, tighten it.

In case the graph does not get optimized the following faults are possible:

The window or the lens of the ceilometer is extremely dirty.

The Optical termination hood required during the indoor adjustment is dirty or missing.

Other possible faults are the following:

Compensation Fiber itself is defective.

Receiver is damaged.

Beamsplitter at the lower end of the Optical Subassembly is broken etc.

In the latter case consult Vaisala.

4. Press the Esc key one or two times to stop the compensation monitoring.

5. Set the autoadjustments on with the following command:

```
SET DATA_ACQ AUTOADJ ON↵
```

6. Wait for some minutes. Give the command

```
GET STATUS↵
```

Check from the status message under the title Receiver that the COMP values, which are fine adjusted by the software, are close to the original 13 (Coarse) and 125 (Fine). In case either of these values has changed more than 3 steps, calculate the following sum:

$$17 \times \text{Coarse} + \text{Fine}$$

If this value remains in the range 300 ... 400, it is acceptable.

7. Wait again for at least one measurement cycle (15 seconds), and give the GET STATUS command. Check once more from the status message the Receiver COMP values. These should be the same as before, indicating that the automatic adjustment has stabilized.
8. Turn the power off and start the Ceilometer again in order to verify that the unit is operating properly.

Receiver CTR21

Removal

WARNING

Hazardous voltage 500 V is present at the Receiver and at the Board Frame DMF51. Both the line and the battery switches must be turned off before removing the Receiver.

When there is reason to suspect malfunction of the Receiver (i.e. Receiver Failure Alarm or Receiver Optical Crosstalk Compensation Poor Warning exist) follow the instructions below (First note section Start-Up Procedure for Replacement (All Parts) on page 122). In case there is reason to suspect failure in the Coaxial Cable instead of the Receiver, refer to section Coaxial Cable Replacement on page 136. In case the compensation fiber is suspected, refer to section Compensation Fiber on page 138.

1. Detach the Compensation Fiber from the receiver by loosening the screw (See Figure 34 below) with a 1.5 mm hexagon key and pulling the fiber end gently out. Do not twist the compensation fiber.
2. Detach the Receiver Ribbon Cable Connector from the connector J11 at the DMF51 Board Frame by pressing the connector latches apart. Refer to Figure 30 on page 123.
3. Detach the Coaxial Cable from the DCT52 front panel.
4. Loosen the attachment ring (See Figure 34 below) using a 2.5 mm hexagon key as a lever; there are holes in the attachment ring for that purpose. If the Receiver begins to move along, stop it by hand. The photo diode has been centered at the factory - **do not apply force to the Receiver because that may disturb the centering**. Take the receiver into your hand and detach the Coaxial Cable from it.
5. Send the defective receiver to Vaisala.

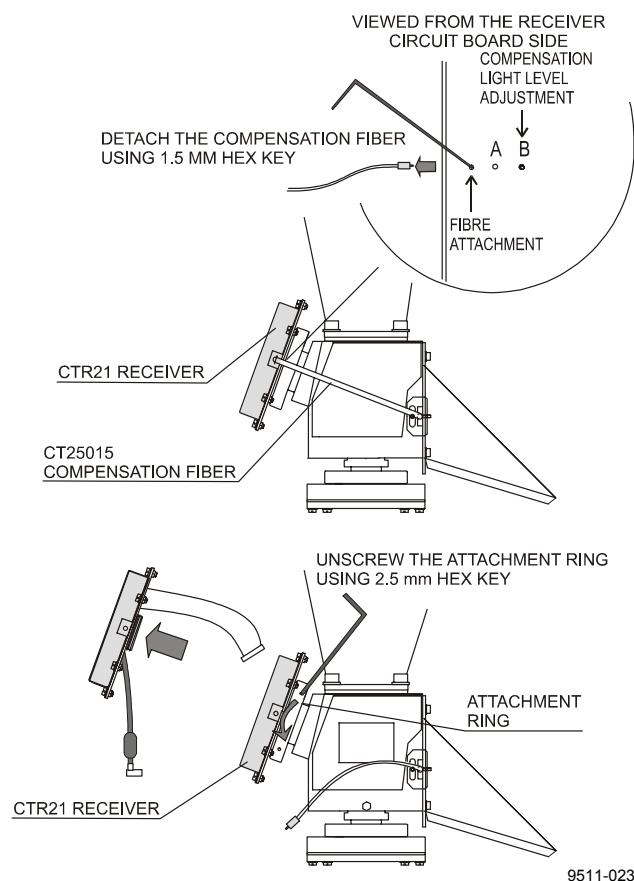

Figure 34 Removing the Receiver

Replacement

To replace Receiver CTR21 (Refer to section Start-Up Procedure for Replacement (All Parts) on page 122):

1. Attach the Coaxial Cable to connector J2 at the receiver. Note the marked ends of the cable.
2. Take the Receiver into your hand and set it in place. Note the right position, the ribbon and coaxial cables come out from the back side. Rotate the attachment ring (see Figure 34 on page 133) first by hand and then tighten it using a 2.5 mm hexagon key as a lever. If the receiver begins to move along, carefully stop that by hand.

NOTE

Do not apply force to the receiver itself because it may disturb the centering.

Check that the receiver is now in the correct position, that is, the long edges of the receiver case are approx. horizontal. If this is not the case, loosen the attachment ring first, then correct the receiver position and fasten as described above.

3. Plug the Compensation Fiber into the receiver and tighten the screw (marked Fibre attachment) with a 1.5 mm hexagon key.
4. Attach the Coaxial Cable to the J1 connector at the front panel of DCT52.
5. Attach the ribbon cable connector to DMF51 Board Frame connector J11. Refer to Figure 30 on page 123.
6. Connect the Power Cable and the Maintenance Terminal. Turn the power on.
7. If the receiver has been replaced by a new one, do the following parameter settings:
 - a. Open the command set by first typing OPEN↵ at the command prompt and then typing the password ADVANCED↵.
 - b. Adjust the internal crosstalk compensation according to section Compensation Adjustments on page 128.
 - c. Turn the power off and start the Ceilometer again in order to run the automatic receiver self-check.

- d. Open the command set by first typing OPEN↵ at the command prompt and then typing the password ADVANCED↵.
- e. Interrupt autoadjustments with the command STOP↵

Then give the following commands:

```
SET PORT TIMEOUT 20↵
```

Sets the timeout of the dialog to 20 minutes.

```
SET DATA_ACQ INTERVAL 15↵
```

Sets minimum measurement interval.

- f. Give the command GET STATUS↵

Wait until the SENS parameter under the title Receiver in the status message gets a value. It may take a couple of minutes, because the automatic receiver self-check is performed during the fourth measurement cycle.

Check that the SENS value is OK. The receiver sensitivity tells you the present measured receiver value compared to the factory setting. If the SENS value is OK, the receiver installation is ready and you can skip steps g. and h.

- g. If the SENS value is not within range, i.e. *FAIL is shown, type the following command

```
GET VALUE OTHERS RECVALUE↵
```

which prints the measured receiver test value and the value compared to the present factory setting in % on your screen. Note the RECEIVER TEST VALUE and write it down.

Then give a new receiver factory value with the command

```
SET FACTORY RECVALUE
```

and type the recent value (first value of the two, NOT the percentage) of the output RECEIVER TEST VALUE.

- h. Wait until a few measurement cycles have been completed. Give the command

GET STATUS↵

Check in the status message the SENS value, which should be OK.

8. Turn the power off. Start the Ceilometer again and verify that it is operating properly.

Coaxial Cable Replacement

In case Receiver Failure Alarm or Receiver Optical Crosstalk Compensation Poor Warning exist, the reason may be a defective Coaxial Cable instead of a Receiver.

WARNING

Hazardous voltage 500 V is present at the Receiver and at the Board Frame DMF51. Both the line and the battery switches must be turned off before removing the Coaxial Cable.

Removal

To detach the Coaxial Cable, you have to detach the receiver first as follows:

1. Detach the Compensation Fiber from the receiver by loosening the screw (See Figure 34 on page 133) with a 1.5 mm hexagon key and pulling the fiber end gently out. Take care not to twist the compensation fiber.
2. Detach the Ribbon Cable Connector of the Receiver from the connector J11 at the DMF51 Board Frame. Refer to Figure 30 on page 123.
3. Detach the Coaxial Cable from the DCT52 front panel.
4. Loosen the CTR21 Receiver attachment ring (See Figure 34 on page 133) using a 2.5 mm hexagon key as a lever; there are holes in the attachment ring for that purpose. If the Receiver begins to move along, stop it from rotating by hand.

NOTE

The photodiode has been centered at the factory - do not apply force to the Receiver because this may disturb the centering.

5. Take the receiver in your hand and detach the Coaxial Cable from the receiver.
6. If the Coaxial Cable is found defective, replace with a new one (refer to section Replacement below.)

Replacement

To replace the Coaxial Cable (see section Start-Up Procedure for Replacement (All Parts) on page 122 for replacement):

1. Attach the new Coaxial Cable to connector J2 of the receiver. Note the marked ends of the cable.
2. Take the Receiver CTR21 in your hand and set it in place. The ribbon and coaxial cables come out from the back side. Rotate the attachment ring (see Figure 34 on page 133) first by hand and then tighten it using a 2.5 mm hexagon key as a lever. If the receiver begins to move along, carefully stop it by hand from rotating.

NOTE

Do not apply force to the receiver itself because it may disturb the centering.

Check the receiver correct position, that is, the long edges of the receiver case are approx. horizontal. If this is not the case, loosen the attachment ring first, then correct the receiver position and fasten as described above.

3. Plug the Compensation Fiber into the receiver and tighten the screw (marked Fibre attachment) with a 1.5 mm hexagon key.
4. Attach the Coaxial Cable to the connector J1 at the front panel of DCT52.
5. Attach the ribbon cable connector to the DMF51 Card Cage to connector J11. Refer to Figure 30 on page 123.
6. Connect the Power Cable and the Maintenance Terminal. Turn the power on. No parameter settings are needed. Verify that the Ceilometer is operating properly.

Compensation Fiber

Compensation Fiber Replacement

The Compensation fiber is made from optical fiber. Handle the fiber with care. Don't twist. Do not allow the ends of the fiber to be contaminated by grease or dust.

When there is reason to suspect malfunction of the Compensation fiber (CT25015) do as follows: (See section Startup Procedure on page 32.)

1. Identify the black compensation fiber, which leads from the CTR21 Receiver to the Center Block of the optics tube. See Figure 32 on page 129.
2. Check with care the position and alignment of the fiber at the Center Block end: The fiber is attached with a flat metal part, which is also supplied with the new fiber. Mark the position of the edges of this part in respect to the Center Block with a pencil.
3. Open the **fiber attachment screw** at the receiver bottom (shown in Figure 32 on page 129) with a 1.5 mm hex key. Take this fiber end gently out from the receiver.
4. Open the **M3 slotted head screw** (sealed with red paint) that fixes the fiber to the Center block. Look at the replacement fiber and carefully note the shape of the end of the fiber. Take the hooked fiber end carefully out from the center block.
5. You can visually compare the old and new fibers now. If the old fiber is totally broken, no light is seen transmitted through it, when one end of the fiber is pointed towards a lamp or other light source. If there are only fractures in the fiber, the light is dim at the other end of the fiber.
6. Try to place the new fiber exactly in the same place as the original one was. Tighten the two attachment screws mentioned.
7. Perform steps 3 and 4a & 4b under the title Replacement on page 125.
8. Perform the Compensation adjustments, all steps under the title Compensation Adjustments on page 128.
9. Turn the power off. Then start the Ceilometer again and verify that it is operating properly.

NOTE

If you run into trouble performing step 8 above, such that the adjustment is not finished because screw B has already traveled all the way out from the receiver, you also have to adjust the other end of the fiber. (This can be quite laborious.) In this case follow these next steps:

10. Turn the B-screw back clockwise until it is several turns inside the threads. (Approximately in the original position).
11. Perform steps 1 ... 3 of section Compensation Adjustments on page 128 adjustments again. During step 3, however, loosen slightly the M3 slotted head screw and make very small adjustments to the position of this fiber end. The purpose of these adjustments is to increase the level of optical power that is coupled into the fiber. This effect is seen in the terminal display so that the amount of stars increases, the "empty hole" is filled and finally a case at the bottom left (or upper middle) in Figure 33 on page 131 is reached. When this is achieved, tighten the M3 slotted screw well again and make the fine adjustment with the B-screw. Secure the M3 screw with red paint. Continue to finish the replacement operation as in steps 8 and 9 above.

NOTE

The adjustments at the Center Block end must be very small (0.2 mm or so) and you have to wait a couple of seconds before the effect is seen on the terminal.

Optics Monitor CTL21

Removal

When there is reason to suspect malfunction of the Optics Monitor do as follows: (See section Start-Up Procedure for Replacement (All Parts) on page 122.)

1. Detach the ribbon cable connector from the Optics Monitor CTL21.
2. **Mark (with pencil) the position** of the CTL21 in order to replace it correctly.

3. Loosen the two screws (Figure 35 below) with a screwdriver. (The optics monitor ribbon cable remains attached to section Optical Subassembly CTB22 on page 74.)
4. Send the defective Optics Monitor to Vaisala.

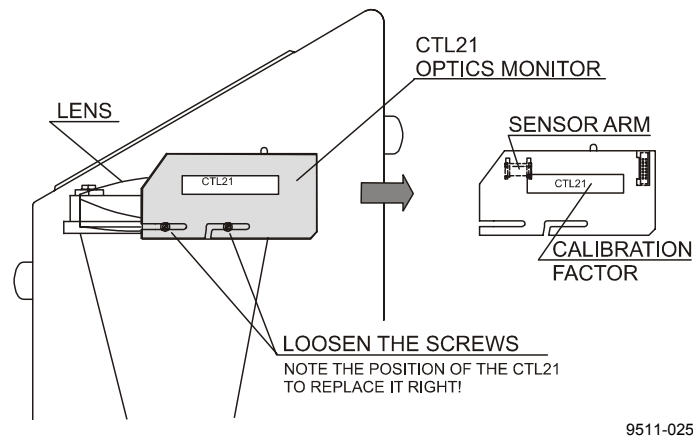

Figure 35 Removing the Optics Monitor

Replacement

To replace Optics Monitor CTL21:

1. Fasten the Optics Monitor CTL21 to the Ceilometer with two screws (Figure 35 above). The previous horizontal position of the CTL21 is a good estimate of the correct position. (The Sensor Arm of the Optics Monitor should be about in the middle of the lens.)
2. Attach the ribbon cable connector to the CTL21.
3. Connect the Power Cable and the Maintenance Terminal. Turn the power on.
4. If the Optics Monitor has been replaced or the horizontal position of it has been changed, do the following:
 - a. Do the parameter settings for the Laser Transmitter CTT21 as described in section Replacement on page 125, Steps 4 a ... j, finishing with the Internal Crosstalk Compensation (section Compensation Adjustments on page 128).
 - b. Do the parameter settings for the Receiver CTR21 as described in section Replacement on page 134, Steps 7 c ... h. It is not necessary to adjust the Internal Crosstalk Compensation again.

Boards of Board Frame DMF51

The boards of Board Frame DMF51 are shown in Figure 36 below. Replacement of boards does not require parameter settings except the Ceilometer Interface Board DCT52, the adjustments of which are described in section Parameter Settings of Ceilometer Interface Board DCT52 on page 142.

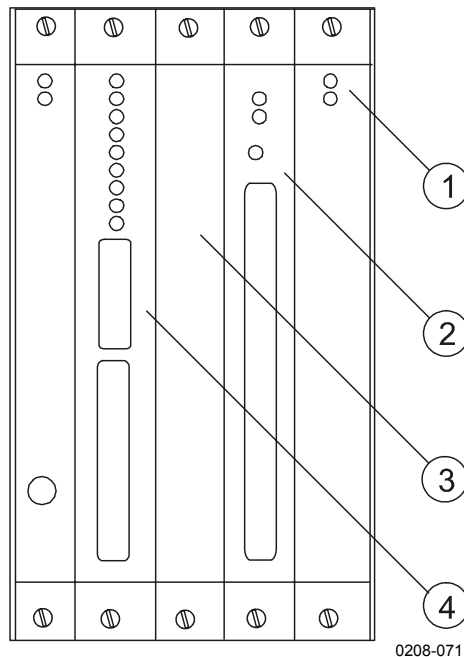

Figure 36 Boards of the DMF51 Board Frame

The following numbers refer to Figure 36 above:

- 1 = DPS52 DC Converter board
- 2 = DMC50B Processor board
- 3 = Modem board (optional)
- 4 = DCT52 Ceilometer interface board

Removing Boards

Before removing boards, note section Start-Up Procedure for Replacement (All Parts) on page 122.

1. Detach the connectors that are plugged into the board you want to remove.
2. Detach the two screws at the upper and lower end of the board front panel (Figure 36 above). Because the board frame is tightly

packed it is recommended to loosen the screws of the adjacent boards. The adjacent board may be partly pulled out to help the removal.

3. Pull the board carefully out from the slot.

Replacing Boards

1. Plug the new board carefully into the corresponding slot (Figure 36 on page 141).
2. Attach the new board with the two screws. Then plug in connectors. Cable connections were described in section Cable Connections on page 28.
3. When the Ceilometer Interface Board is replaced, the parameters need to be restored, refer to section Parameter Settings of Ceilometer Interface Board DCT52 below. The other boards of the board frame DMF51 do not need parameter settings. If the DMC50 Processor board has been replaced, the software version of the new board can be checked with the command: `GET VERSION` ↵

Parameter Settings of Ceilometer Interface Board DCT52

- a. The default baud rate for the maintenance line is 2400 Bd, 7 data bits, 1 Stop bit, Even parity. If some other baud rate was previously used with the removed DCT52, you may have to adjust your maintenance terminal to the default setting to be able to communicate with the ceilometer.
- b. Do the parameter settings for the Laser Transmitter CTT21 as described in section Replacement on page 125, Step 4. The internal Cross talk Compensation does not need adjusting in this case. Instead, give the command: `SET ALGORITHM DEFAULTS` ↵
- c. Do the parameter settings for the Receiver CTR21 as described in section Replacement on page 134, Step 7. The internal Cross talk Compensation does not need adjusting. Instead, give the command: `SET DATA_ACQ AUTOADJ ON` ↵
- d. Restore the maintenance and data line communication speed, message type, interval, units etc. as required, if defaults are not to be used.

Line & Power Subassembly CTP241

Removal

When there is reason to suspect malfunction in the Line & Power Subassembly (CTP241), do as follows:

WARNING

The Line & Power Subassembly contains dangerous voltage of 115 VAC/230 VAC. Turn the power off according to section Start-Up Procedure for Replacement (All Parts) on page 122 before you continue.

NOTE

If the Ceilometer is installed outdoors and a replacement unit is not immediately available, it is advisable either to bring the unit indoors or cover the exposed opening with tape to protect the interior against water, insects, etc.

1. If the Ceilometer is mounted on a pedestal, loosen the two attachment screws and tilt the Ceilometer to a horizontal position. If the Ceilometer is already demounted from the pedestal and brought indoors, place the unit on a table with the door upwards.
2. Remove the protective cap of the External Connector J4 (Maintenance Line), if the cap is attached. (All cables must be disconnected from the External Connectors J1 ... J4).
3. There are 6 screws at the bottom of the CT25K that are situated **around** the rectangular opening of external connectors J1 ... J4 (See Figure 37 on page 144). Loosen these screws so that they come out approx. 1 cm (do not remove them completely), releasing the flange of the CTP241.
4. Turn the ceilometer to a vertical position again.
5. Detach the Internal Heater Cable by pressing the right and left clips of the mating connector at J5 on the CTP241.
6. Disconnect the AC Power Interface Connector P6 from the Board Frame DMF51 (J15). Refer to Figure 30 on page 123.
7. Disconnect the plug-in Connectors P7 and P8 from the DMC50 Processor Board and modem, if installed.

8. Open and remove the screw and spacer that connects the CTP241 to the battery holder, see Figure 37 below.
9. Lift the left front corner of the CTP241 approx. 1 cm and pull it out.

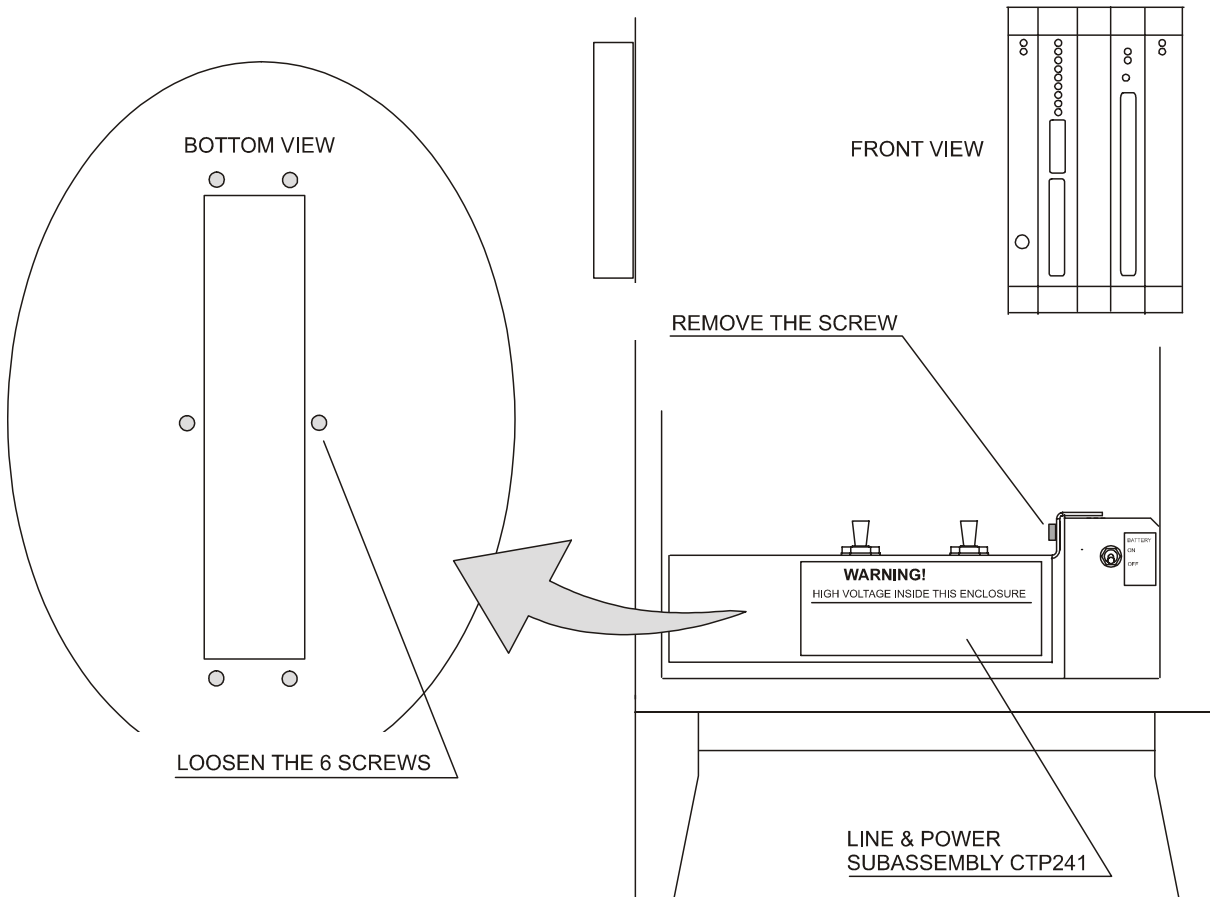

9605-023

Figure 37 Removing Line and Power Interface Subassembly CTP241

Replacement

WARNING

The Line & Power Subassembly contains dangerous voltage of 115 VAC / 230 VAC even when the Power Switch F1 is turned off. Do not connect the Power Cable to an unmounted Line & Power Subassembly.

NOTE

Before connecting power check the voltage setting of the CTP241 Line and Power Interface (voltage setting shown between the switches F1 and F2, see Figure 8 on page 33).

1. Take the CTP241 in your hand. Turn cables P6...P8 so that they stay on the cover of the subassembly. Set the CTP241 in its place.
2. Set the screw and spacer that connects the CTP241 to the battery holder in places. Tighten the screw slightly by fingers, see Figure 37 on page 144.
3. Connect the plug-in Connectors P7 and P8 to the DMC50 Processor Board and modem, if installed. See the drawing on the front panel for the correct positions.
4. Connect the AC Power Interface Connector P6 to the Board Frame DMF51 (J15). Refer to Figure 30 on page 123.
5. Plug Internal Heater cable into connector J5 on the CTP241.
6. Turn the Ceilometer to horizontal position.
7. Turn the 6 screws at the bottom of the CT25K clockwise (Figure 37 on page 144) and push then slightly until they go through the holes in the gasket of the connector flange. Then tighten the screws normally.
8. Tighten the screw that connects the CTP241 to the battery holder (Figure 37 on page 144) to normal tightness.
9. Attach the cables to External Connectors J1-J4.
10. Turn the Ceilometer to vertical position and tighten the screws of the pedestal.
11. Verify that the Ceilometer is operating properly.

Internal Heater Subassembly CT25039 Replacement

1. Remove the following connectors:
 - Optics Monitor CTL21 connector P2
 - Laser Transmitter CTT21 connector P3
 - Receiver CTR21 connector P1
 - Coaxial Cable CT3696 connector P1

2. Take a good hold on the CTB22 Optical Subassembly from the black part with one hand. Do not touch the transmitter, receiver or the black cone on the opposite side of the receiver. Open the two screws shown in Figure 38 on page 147 using a 6 mm hex key with the other hand.
3. Carefully remove the optics subassembly. Do not touch the compensation fiber. Place the optics subassembly carefully on the table so that the laser transmitter and the receiver do not touch the table.
4. Open the four nuts at the corner of the internal heater.
5. Disconnect the wires and replace the heater with a new subassembly.
6. Assemble CTB22 Optical Subassembly and cables back in their original positions.

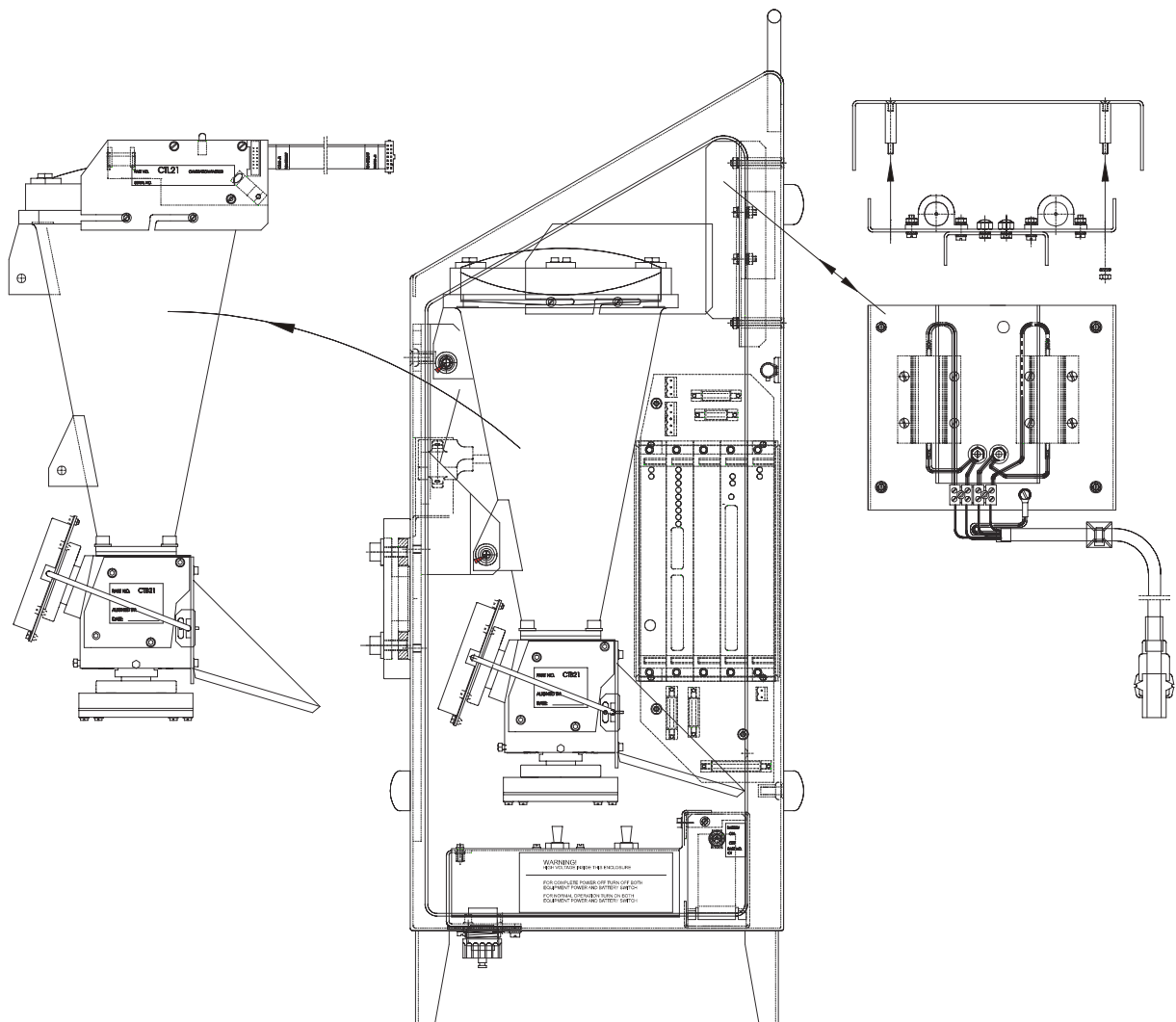

9805-011

Figure 38 Internal Heater Replacement

Battery 4592 Replacement Instructions

1. Open the screw from the battery switch subassembly front panel shown in Figure 39 on page 148 and remove the panel.
2. Pull the battery out by the plastic stripe attached around the battery. Do not pull by the battery switch connector wires.
3. Detach the red and black wires from the battery and move them to the new battery. Transfer the plastic pull-out stripe to the new battery.

- Put the battery back in its original position and close the front panel with the attachment screw.

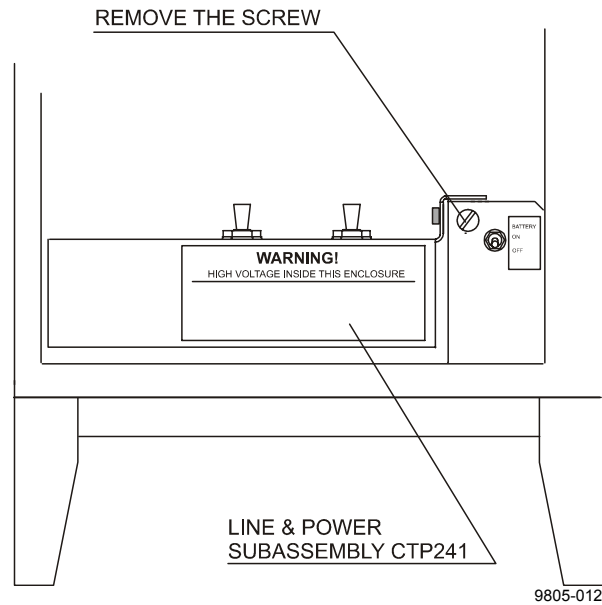

Figure 39 Battery Replacement

Getting Help

For technical questions or for comments on the manuals, contact the Vaisala technical support:

E-mail	helpdesk@vaisala.com
Telephone	+358 9 8949 2789
Fax	+358 9 8949 2790

Return Instructions

If the product needs repair, please follow the instructions below to speed up the process and avoid extra costs.

1. Read the warranty information.
2. Write a Problem Report with the name and contact information of a technically competent person who can provide further information on the problem.
3. On the Problem Report, please explain:
 - What failed (what worked / did not work)?
 - Where did it fail (location and environment)?
 - When did it fail (date, immediately / after a while / periodically / randomly)?
 - How many failed (only one defect / other same or similar defects / several failures in one unit)?
 - What was connected to the product and to which connectors?
 - Input power source type, voltage and list of other items (lighting, heaters, motors etc.) that were connected to the same power output.
 - What was done when the failure was noticed?
4. Include a detailed return address with your preferred shipping method on the Problem Report.
5. Pack the faulty product using an ESD protection bag of good quality with proper cushioning material in a strong box of adequate size. Please include the Problem Report in the same box.
6. Send the box to:
Vaisala Oyj
SWD Service
Vanha Nurmijärventie 21
FIN-01670 Vantaa
Finland

This page intentionally left blank.

CHAPTER 9

TECHNICAL DATA

This chapter provides the technical data of the CT25K Ceilometer.

Specifications

Mechanical

Table 19 CT25K Ceilometr Mechanical Specifications

Property	Description / Value
Dimensions:	
Measurement unit	760 x 280 x 245 mm (30 x 11 x 10 in.)
Height with shield and pedestal	1320 mm (52 in.)
Weight:	
Measurement unit	17 kg (37 lb.)
Shield	10 kg (22 lb.)
Metal pedestal	8 kg (17 lb.)
Fiberglass pedestal (option)	13 kg (28 lb.)
Cardboard transport container size	1170 x 740 x 430 mm (46 x 29 x 17 in.)
Cardboard transport container weight	51 kg (111 lb.)
Plywood transport container size	1240 x 760 x 450 mm (49 x 30 x 18 in.)
Plywood transport container weight	70 kg (152 lb.)

External Connector J1 - Window conditioner

Table 20 Window Conditioner

Property	Description / Value
Connector J1:	Type Binder series 693, 09-4228-00-07 (female)
Mating connector type:	Type Binder series 693, 99-4225-70-07 7-pin (male) elbow

External Connector J2 - Power input

Table 21 Power Input

Property	Description / Value
At nominal line voltage	100/115/230 V
Power consumption (typical)	
Total	365 W
Measurement unit	15 W
Internal heater	120 W
Window conditioner heater	200 W
Window blower	30 W
Frequency	45-65 Hz
Power connector (J2):	Type Binder series 693, 09-4223-00-04 4-pin (male)
Mating connector type:	Type Binder series 693, 99-4222-70-04 (female) elbow
No-break power supply	12V Sealed Lead Acid Battery, 2.1 Ah
Overvoltage Protection	Low-press filter , VDR

Output Interface

The data port can operate according to the following serial line standards :

RS-232

RS-422

RS-485, multidrop, 2-wire / 4-wire

The data port can also be operated through DMX55 and DMX50 modems.

The maintenance port is an RS-232 serial line, except when the data line is set to RS-422 or RS-485; then the maintenance line voltage levels become 0 and +5 V.

External Connector J3 - Data line

The data line is intended to be used for measurement data communication, but it can also be used with Ceilometer Maintenance Terminal, PC or other terminals.

Table 22 Data Line

Property	Description / Value
Connector (J3):	Type Binder series 693, 09-4227-00-07 7-pin (male)
Mating connector type:	Type Binder series 693, 99-4226-70-07 (female) elbow
Baud Rate:	2400 baud standard with RS-232 300, 4800 and 9600 baud available 300 bit/s with modem DMX55 2400 bit/s standard with modem DMX50 300, 1200, 2400 bit/s available Data compression allows up to 9600 bit/s throughput
Max. Distance to Operate:	300m (1000 ft) with RS-232, 1.2 km (4000 ft) with RS-422 and RS-485, all at 2400 baud with typical communication cables 16 km (10 mi) with Modem 16 km (10 mi) with Modem
Standard Character Frame:	1 Start Bit 7 Data Bits Even Parity 1 Stop Bit
Standard Character Code:	USASCII
Pin Connections:	1 RD- / AN2Lo 2 Modem Lead A / RxD / RD+ / AN1Hi 3 Modem Lead B / TxD / SD+ / AN1Lo 4 Signal Ground 5 SD- / AN2Hi 6 +12 V DC supply (200 mA max for 1 hour, 100 mA continuous, for external equipment)

Modem circuits are non-polar and symmetrical. All modem circuits are electrically floating to overvoltage protection rating (300V-500 V).

Overvoltage Protection in each circuit:	Primary Secondary	Noble Gas Surge Arrester VDRs, Transient Zener Diodes or normal Diodes
---	----------------------	--

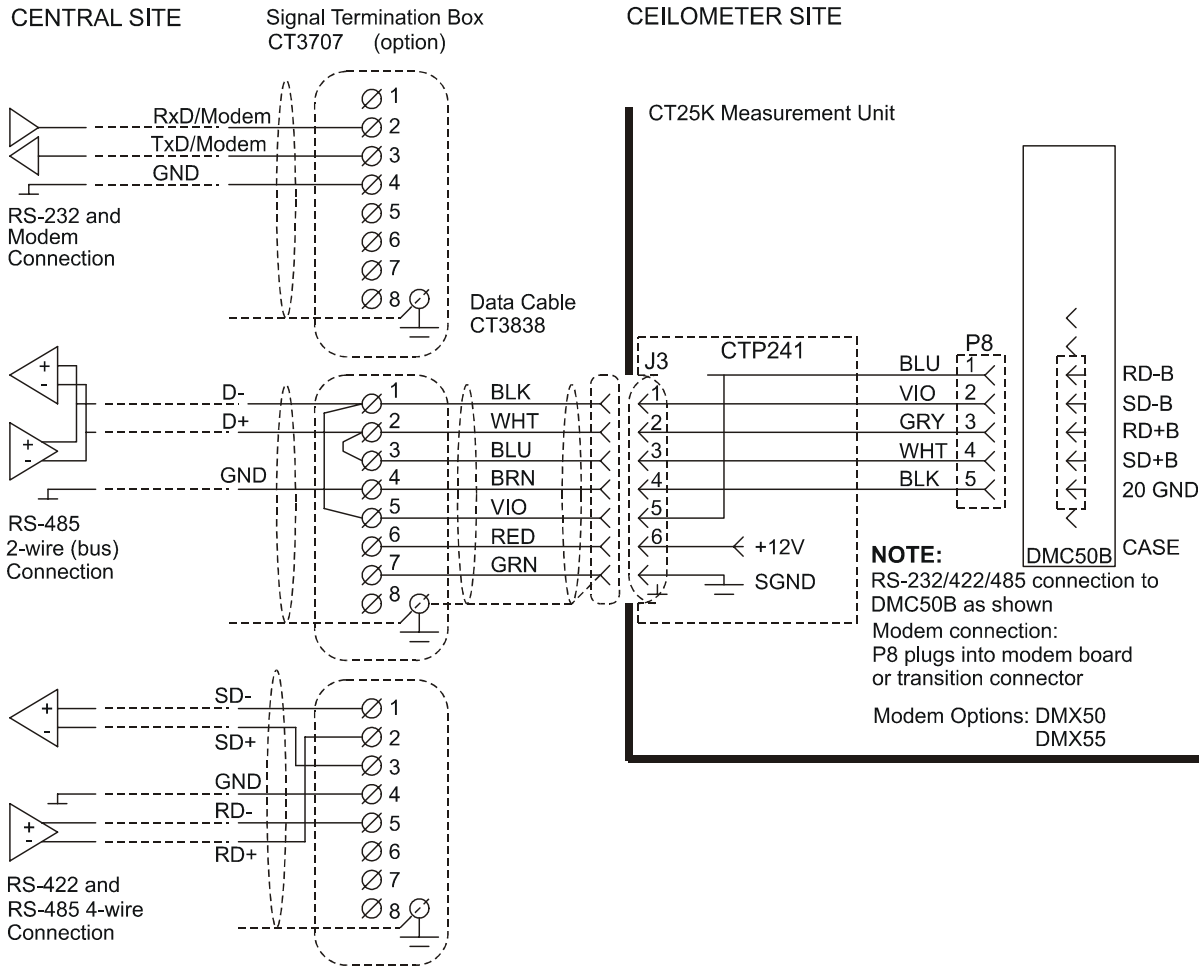

9807-045

Figure 40 Data Line Connection Options

External Connector J4 - Maintenance Line

Maintenance line is intended for on-site maintenance and can be used with Ceilometer Maintenance Terminal, PC or other terminal.

Table 23 Maintenance Line

Property	Description / Value
Connector (J3):	Type Binder series 693, 09-4224-06-04 4-pin (male)
Mating connector type:	Type Binder series 693, 99-4221-70-04 (female) elbow
Baud Rate:	2400 baud standard and default 300, 4800, 9600 baud available
Distance to Operate:	300 m (1000 ft) at 2400 baud with typical communication cables
Standard Character Frame:	1 Start Bit 7 Data Bits Even Parity 1 Stop Bit
Standard Character Code:	USASCII
Pin Connections	1 RxD / RD+ (0...5 V) 2 TxD / SD+ (0...5 V) 3 +12 V DC supply from internal battery (100 mA continuous, 200 mA max.) 4 Signal Ground / Equipment Ground
Overvoltage Protection in each circuit:	Primary Noble Gas Surge Arrester Secondary VDRs, Transient Zener Diodes or normal Diodes

Modem Options

Modem Board DMX55

ITU-T V.21 / V.23 4-wire full duplex modem interface for serial asynchronous data interchange

Table 24 Modem Board DMX55

Property	Description / Value
Data Rate:	300 bit/s (1200 bits/s V23)
Modulation method:	FSK
Signal Level:	-10 dBm (0.3 V) into 600 Ohm standard (Jumper selectable)
Max. Distance to Operate	0...16 km (0...10 miles) with 22 AWG (0.35 mm ²) unshielded twisted pair

The signal circuit is electrically floating to overvoltage protection rating (300V-500V).

Modem Board DMX50

Table 25 Modem Board DMX50

Property	Description / Value
Processor:	Intel 80C32 custom version
Modem:	Signal Processor Chip Silicon Systems SSI 73K224L
Modem standards supported:	V.21/ V.22/ V.22bis and Bell 103, Bell 212
Modulation method:	300 FSK/ 1200 DPSK/ 2400 QAM
Compression & error correction:	V. 42, V.42bis and MNP 2-5

Adaptive equalization for optimum performance over all lines.

Transmitter

Table 26 Transmitter

Property	Description / Value
Laser Source:	Indium Gallium Arsenide (InGaAs) Diode Laser
Center Wavelength:	905 ± 5 nm at 25 °C (77 °F)
Operating Mode:	Pulsed
Nominal Pulse Properties at Full Range Measurement:	
Energy:	1.6 μWs ± 20% (factory adjustment)
Peak Power:	16 W typical
Width, 50%:	100 ns typical
Repetition Rate:	5.57 kHz
Average Power:	8.9 mW (full range measurement)
Max Irradiance:	170 μW/cm ² measured with 7 mm aperture
Laser Classification:	Classified as Class 1M laser device in accordance with IEC/EN 60 825-1 Class 1 in compliance with FDA CFR 1040.10 (Subsection e,3)
Beam Divergence:	± 0.53 mrad edge, ± 0.75 mrad diagonal

Receiver

Table 27 Receiver

Property	Description / Value
Detector:	Silicon Avalanche Photodiode (APD) Responsivity at 905 nm: 65 A/W (factory adjustment)
Surface Diameter:	0.5 mm (0.02 in.)
Interference Filter:	Center wavelength 908 nm typical
50% Pass Band:	35 nm at 890-925 nm typical
Transmissivity at 905 nm:	80 % typical, 70 % minimum
Field-of-View Divergence:	± 0.66 mrad

Optical System

Table 28 Optical System

Property	Description / Value
Optics System Focal Length:	377 mm (14.8 in.)
Effective Lens Diameter:	145 mm (5.7 in.)
Lens Transmittance:	96 % typical
Window Transmittance:	98 % typical, clean

Performance

Table 29 Performance

Property	Description / Value
Measurement Range:	0...25,000 ft. (0...7.5 km)
Resolution:	50 ft
25,000 ft. Acquisition Time:	min. 15 s max. 120 s
Receiver Bandwidth:	3 MHz (-3db)

Environmental Conditions

Table 30 Environmental Conditions

Property	Description / Value
Ambient Temperature:	-50...+60 °C (-60 ...+140 °F)
Humidity:	to 100 %RH
Wind:	to 100 kt (50 m/s)
Vibration:	0.5 g 5 - 500 Hz

This page intentionally left blank.

INDEX

A		Character code	153
Alarm check	107	CLOSE command	40
Alarms		Coaxial cable	
Laser failure	118	Removal	136
Laser temperature shut-off	118	Replacement	137
Receiver failure	118	Compensation adjustments	128
Voltage failure	118	Compensation fiber	
Angle correction	36	Replacement	138
Angle measurement		Contrast threshold	67
Parameter settings	36	CPU Board	82
APD	72	CT-VIEW	111
Atmospheric transmittance	65	D	
Avalanche photodiode (APD)	72, 77	Data messages	45
Average laser power	156	Data message No. 1	46
B		Data message No. 2	48
Background light	50	Data message No. 3	51
Backscatter	17	Data message No. 4	52
Backscatter coefficient	66	Data message No. 5	52
Battery charger	87	Data message No. 6	52
Bulk charge	87	Data message No. 7	54
Float charge	87	Status message "S"	55
Over charge	87	DC Converter DPS52	85
Trickle charge	87	Internal switch settings	87
Beam divergence	156	LED functions	87
Beamsplitter	72	Output voltages	88
Bird collar	20, 70	Specifications	88
Bird droppings	116	Detector	157
Blink timer	79	Digital display DD50	102
Board frame DMF51	79	E	
Removing boards	141	EEPROM	90
Replacing boards	142	Electrostatic discharge	15
C		Environmental conditions	157
Ceilometer interface board DCT52	89	ESD	15
Centering	124, 125, 134	External connections	28
Changing a prevailing parameter value	35	External connector J1	152
		External connector J2	152

External connector J3	153	M	
External connector J4	155	Maintenance	
Extinction coefficient	66	Alarms and warnings	107
Extinction normalization	67	Battery check	108
F		Manual angle setting	61
Failure diagnosis	119	Manual message	58
Fiberglass pedestal	151	Max irradiance	156
Focal length	157	Measurement mode	50
Foundation screws	23	Measurement parameters	50
Frame DMF51	79	Measurement range	157
G		Measurement signal	63
GET		Measurement unit	68
GET ALGORITHM	59	Meteorological Optical Range MOR	66
GET DATA_AQC	60	Modem board DMX50	156
GET FACTORY	60	Modem board DMX55	155
GET MESSAGE	60	Modem DMX50	100
GET OPER_MODE	61	Connector layout	101
GET PORT	61	LED indicators	101
GET STATUS	55, 61	Safety precautions	100
GET UNIT_ID	61	Switched point-to-point connections	100
GET command	35	Technical description	100
H		Modem DMX55	98
Hard target test	115	Connector layout	99
Height normalization	65	Fixed point-to-point connections	98
I		LED indicators	99
Infrared interference filter	72	Safety precautions	98
Internal heaters subassembly CT25039	92	Technical description	98
Internal voltages	56	MOR	66
Inversion	67	Motherboard	82
L		N	
Laser	156	Narrow-band filter	75
Laser classification	156	No-break power supply	152
Laser diode	76	Noise cancellation	64
Laser safety	77	O	
Laser transmitter CTT21	76	OPEN command	40
Removal	124	Operating principle	63
Replacement	125	Operation modes	
Specifications	156	CONTINUOUS	39
Technical description	76	STANDBY	39
Letter case in commands	40	Optical cross-talk	72, 77
LIDAR	17, 70, 89	Optical filter	157
Lidar equation	65	Optical subassembly CTB22	74
LIDAR measurement	70	Optical system	157
Lidar ratio	66	Optical termination hood	20, 111, 122
Line & power subassembly CTP241	90	Optics monitor CTL21	78
Battery 4592 replacement instructions	147	Removal	139
Removal	143	Replacement	140
Replacement	144	Output interface	152
		Overvoltage protection	152, 154, 155
		P	
		Parts list	69
		Password	41

PC terminal cable	20	SUM	34, 50
Performance	157	Switch settings for normal operation	35
Pin connections	155	T	
PIN photodiodes	78	Temperature	57
Polling mode	58	Termination boxes	19
Polling string	59	Theory of operation	63
Polling string format	45	Thermal switches	92
Power and signal termination boxes	30	Tilt angle	61
Wire dimensions	30	Tilt angle sensor CT3675	94
Power consumption	152	Tilt feature	
Power disconnection	91	Hard target	28
Prevailing control and parameter settings	59	In the tropics	28
Principle of operation	63	Transimpedance amplifier	77
Processor	83	Transmitter	156
Processor board DMC50B	82	Transmitter CTT21	76
A to-D converter	83	Calibration factor	126
DIP switch settings	84	Removal	124
Processor	83	Replacement	125
Serial communication ports	83	Transportation	21
Technical information	84	Tropics window	20, 28
Pulse properties	156	Troubleshooting	
R		Alarms	118
Receiver	157	Warnings	116
Receiver CTR21	77	U	
Coaxial cable replacement	136	User commands	41
Removal	132	V	
Replacement	134	Vertical visibility	67
Specifications	157	Volume backscatter coefficient	65
Technical description	77	W	
Repetition rate	156	Warning check	107
Resolution	64, 157	Warnings	116
Return Instructions	149	Laser power low warning	116
Return signal strength	65	Laser temperature high or low warning	116
Revision history	10	Receiver optical cross-talk compensation	
S		poor warning	117
SCALE	50	Relative humidity >85% warning	117
Secondary APD	72	Voltage high or low warning	117
Serial lines	39	Window contaminated warning	116
CLOSED	40	Wavelength	156
DATA	39	Wedge bolts	23
MAINTENANCE	39	Window cleaning	108
OPEN	40	Window conditioner CT2614/CT2688	96
Service connection	111	Writing conventions	121
SET command	35	X	
Shock absorber	20	xxx-values	113
Sky condition	52, 54, 102		
Activation	103		
Option code	102		
Start up procedure for replacement	122		
Storage	109		



www.vaisala.com