

On the effects of heat and surface treatment on the fatigue performance of high-strength leaf springs

Michail Malikoutsakis^{1*}, Christos Gakias¹, Ioannis Makris¹, Peter Kinzel², Eckehard Müller³, Maria Pappa⁴, Nikolaos Michailidis⁴, and Georgios Savaidis¹

¹Aristotle University of Thessaloniki, Laboratory of Machine Elements and Machine Design, 54124 University Campus Building D, Thessaloniki, Greece

²SOGEFI suspensions heavy duty Italy SRL, 25080 Via Natonale 7, Puegnago sul Garda, Frazione Raffa, Italy

³Hochschule Bochum, 44801, Lennerhofstraße 140, Bochum, Germany

⁴Aristotle University of Thessaloniki, Physical Metallurgy Laboratory, 54124 University Campus Building D, Thessaloniki, Greece

Abstract. Leaf springs constitute the most effective suspension way of commercial vehicle axles from the cost and maintainability point of view. Especially in case of front axles, they overtake both the guidance and suspension functions, which consequently designates them as safety components, whose pre-mature failure is explicitly prohibited. The present paper deals with the fatigue performance of downsized parabolic leaf specimens made of the high-strength spring steel 51CrV4 under serial manufacturing conditions. It focuses on the influence of the major manufacturing steps, i.e. the heat treatment and the subsequently applied stress shot peening. The effectiveness of the applied heat treatment on the microstructure transformation and the extent of surface decarburization is determined by means of optical microscopy and corresponding microstructural analyses. Comprehensive series of constant amplitude fatigue tests are executed before and after the applied stress shot peening to quantify its effectiveness on the fatigue performance. The tests cover two characteristic stress ratios of operational significance with the complete range of interest being experimentally investigated. Additionally, surface residual stresses measurements together with micro- and macro-hardness and roughness values before and after stress shot peening are executed to expose the influence of each individual technological effect on the overall fatigue performance.

1 Introduction

Leaf spring-based suspension systems dominate the commercial vehicle sector since they constitute a cost-effective and maintenance-free solution for both suspending and guiding front and rear axles. On the other hand, and since their presence eliminates the need for other

* Corresponding author: mmalikou@auth.gr

components to regulate the axle travel during operation, they are considered to be safety-critical elements, whose pre-mature or uncontrolled failure should be either completely avoided or properly handled.

Even though their design and form seems fundamental and simplistic, their detailed layout and manufacturing requires high precision and closely-controlled processes, calibrated specifically for such components. In more detail, a series of sequential heat and surface treatments are imperative steps for the production of high-performance, high-strength leaf springs made mainly of the respective high-strength spring-steel alloy 51CrV4.

More specifically, the heat treatments applied during the initial stages allow for the crucial transformation of the initial raw material Pearlitic/Ferritic microstructure into an almost complete (>95%) and uniform quenched and tempered martensite, as well as the preparation of the surface to be furtherly and properly treated. The subsequent shooting of steel shots of various diameters with high velocity at the pre-stressed surface (Stress Shot Peening – SSP surface treatment) of the component's failure-critical side, ensures its superior durability performance.

The present paper is devoted to the quantitative determination of the effects of these heat and surface treatments implemented during the serial production of high-performance parabolic leaf springs, as well as their contribution to the utter fatigue life of downsized specimens under constant amplitude loading for distinctive, operational-relevant stress ratios. The investigation is further expanded to include the comparison of the serial production state with the theoretically improved state of double SSP (re-application of the SSP procedure on the specimens already undergone this procedure already once) and experimentally appraise its fatigue life increase with statistical confidence.

In order to achieve legitimate transferability to the final product, yet significantly decrease the testing time and costs of the experimental investigations, downsized leaf spring specimens were designed and manufactured according to the serial production procedures and protocols. These specimens were made of exactly the same material flat bars as the final product (dimensions acc. to EN 10091-1 [1]), underwent the same heat and surface treatments on the exact same production line, while ensuring enough parabolic (constant stress under bending) length to disengage possible fatigue related size-factors from the final evaluation.

The characteristic stress ratios of $R=0$ and $R=0.5$ were studied to cover the operational mean stress fluctuations and draw the statistically safe conclusions regarding the constant-amplitude fatigue-life S-N curves for the standardized survival probabilities of 50%, 10% and 90% and the respective resulting scatter-band. Additionally, the mean stress sensitivity factors were also resolved for the first time for this material state and loading mode.

Finally, residual stress profiles over the depth of the peened surfaces of selected specimens have been determined to acquire the actual effective stress state that will eventually lead to fatigue failure. The above assessment is supported by and supplemented with macro- and micro-hardness measurements in conjunction with roughness properties that offer an overall evaluation of the surfaces' competence and durability performance.

1.1 Design and manufacturing of downsized specimens

Besides the transferability concerns, which are mainly directed towards the adequacy of the evenly stressed parabolic length of the specimens' arms, the downsized specimens are designed in such a way to address the test rig configurations available for fatigue testing, as well as the necessity to speed up the testing process overall. Therefore, the specimens are designed to be shorter than the actual leaf spring products in order to decrease the spring travel (higher spring rate under bending) and consequently increase the testing frequency, considering the servo-hydraulic nature of the test rigs to be used.

Moreover, the manufacturing process of these pieces is by no means any different than the final product, following meticulously all the necessary procedures and treatment as the serial leaf springs. The same-day, same-batch approach adopted for the production of all 150 specimens necessary for fatigue testing, as well as metallographic and surface inspections, ensured that no batch-production effects would influence the results in any way whatsoever.

Flat bars of profile C with dimensions 90x32mm (= width x thickness) and nominal delivery conditions and tolerances according to EN 10092-1 [1] were cut into proper length pieces to produce the nominal design of the specimens shown in Figure 1. It is noted that the drawing illustrated hereby presents the specimen in the so-called “stretched” position, which is actually a position achieved after the application of a certain load depending on the clamping condition (clamped or unclamped). The physical unloaded or “out-of-the-self” condition of the spring has an arched shape, with the central clamping length area being higher than the points of contact with the supporting cylinders.

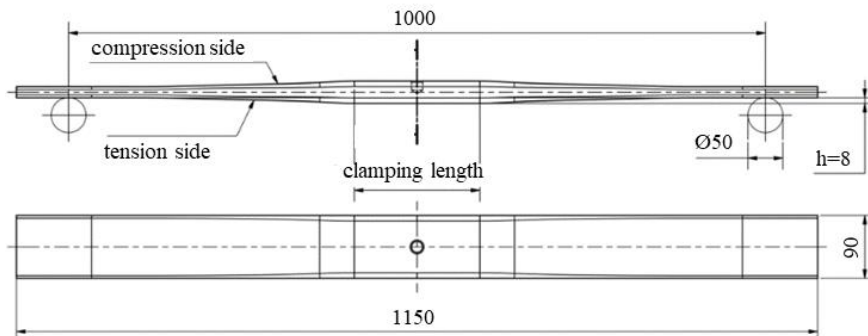

Fig. 1. Drawing of the test specimens (stretched position).

The designed leaf specimens are symmetric, i.e., the front and rear arms exhibit the same thickness distributions along their lengths, while the supporting cylinders are placed each at 500mm away from the center, leaving about 150mm of parabolic (=constant stress) length at each arm of the specimen. This length is considered adequate to incorporate all production effects and random events that might occur in the serial production line and result to the same (one to one) fatigue behaviour with the final product. It is furtherly emphasized that special attention was paid to the treatment of the profile’s round areas in order to portray realistic geometric transitions, since these areas have been proven to be prone to premature failures owed mostly to production faults but also design-related, usually overlooked mistakes.

Figure 2 presents the FE simulated stress distributions over the specimen length for both “unclamped” and “clamped” conditions for the same characteristic vertical load values. It is noted that these terms refer to the conditions at which the “clamping area” depicted in Figure 1 is either left as is, or assembled and tightened together with thick and stiff plates of the same length and larger width, using bolts with the proper pretension to force the whole “clamped” area to remain practically undeformable, respectively. Therein, the almost constant stress area length can be easily identified (around 150mm as mentioned above, i.e. from 200mm to 350mm away from center). Taking the symmetry of the front and rear arm into account, the comparison between unclamped (left side) and clamped (right side) states depicts the independence of the overall stress distribution and consequently the developed maximum stress from the spring rate.

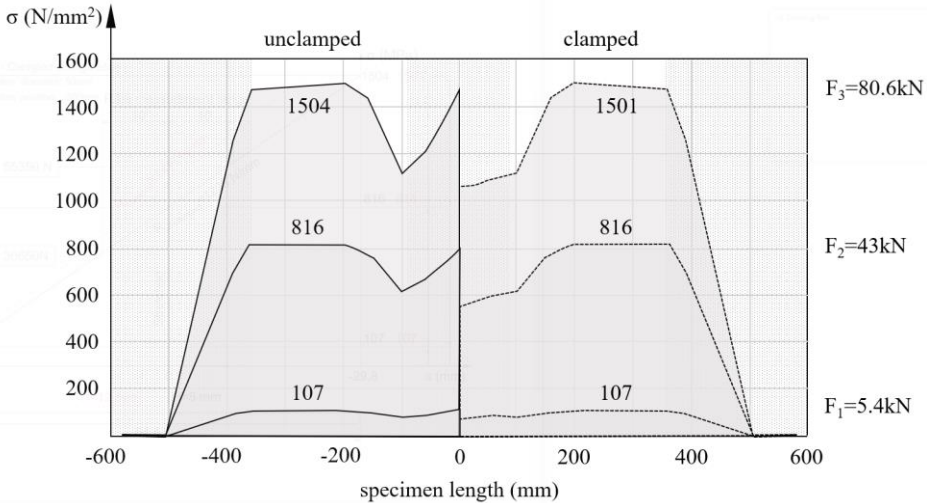

Fig. 2. Test specimens' stress distributions in the unclamped and clamped configurations.

The manufacturing process consists of the sequential cutting, forming and overall treating of the raw material flat bars with caution and precision, since failing to comply with the strict tolerance bands of any production step has a dominant impact on the durability performance of the final product. The first seven steps described in the list below result to the Heat Treated and Tapered (HTT) state of interest, while the rest four steps lead to the final product (SSP) state. It is noted that the double SSP state is achieved by repeating the tenth step prior to the finishing eleventh.

1. Cutting of the profile to proper length pieces
2. Pre-heating of the constant-thickness profile to 860°C passing through a gas-heated flame furnace to achieve the prescribed temperature over the whole piece.
3. Tapering of the pieces to the prescribed thickness distribution using CNC robotic tapering machinery.
4. Heating through a gas heated flame furnace up to 830°C for 60min.
5. Initial shape forming (bending) to acquire the basic shape of the spring (initial camber).
6. Quenching of each piece by passing it through an oil bath (at 60 to 80 °C) immediately after the initial shape forming to achieve the proper cooling gradient of max 80 deg/sec. This procedure yields the martensitic transformation and its goal is to acquire a >90% martensitic structure (typically approx. 95%).
7. Tempering of the specimens by re-heating up to up to 425°C for 90min and letting them cool down slowly into air in order to relieve all residual stresses induced by the previous processes. It is noted that an inevitable by-product of this heat treatment is the partial and layered decarburization of the surface.
8. Pre-setting (scragging) of the specimen by 3-point bending up to approx. 2300MPa to locally plastify the surface layers and prepare it for SSP. The elastic limit of the part, based on the yield strength of approx. 1440 to 1575 MPa, is now translated to >1850 MPa.
9. Pre-setting of the specimen by 3-point bending up to 1650MPa to hold this stress level for the SSP process
10. Serial Stress Shot Peening of the specimen through a Peening machine equipped with 4 turbines able to accelerate the operating mixture (sieve analysis: max. 12% of > 1.7mm

and min. 70% of >1.18mm) of S460 shots with a velocity of about 83m/sec, an Almen intensity of >0.55mm Almen A (typical values 0.65 – 0.7mm Almen A) and a coverage of >98% (acc. to the definition of SAE J 443, [2]).

11. Post-setting of the specimen by 3-point bending between the elastic limit (>1850MPa) and the scragging stress (<2300MPa) in order to evenly redistribute the favourable compressive residual stresses, without causing though their extensive relaxation. This treatment is only applied when further adjustment of the leaf height is needed for the finished product.

1.2 Surface properties

As already mentioned, the surface state characterization is based on the residual stress plots over the depth of the Stress Shot Peened surface, as well as the macro-hardness measurements and micro-hardness respective distributions which correlate the stress state with the material's strength properties. The investigation is supplemented by the roughness values that ensure the absence of surface flaws and early fatigue initiation sites owed to an improper wrinkledness.

Two specimens' surfaces, one subjected to serial and one subjected to double SSP were thoroughly investigated to determine the aforementioned states. Both samples were serially produced, meaning that there is an inevitable extent of decarburization on the surface, as a side effect of the heat treatment. The production induced Almen C intensity value is 0.2 mm and the pre-stress is around 1750 MPa, while the peening time from entering to leaving the shot peener is around 50-60 seconds with 4 turbines shooting a mass of 500 kg per turbine per minute. The measured compressive residual stress distributions are shown in Figure 3 over the depth from the surface.

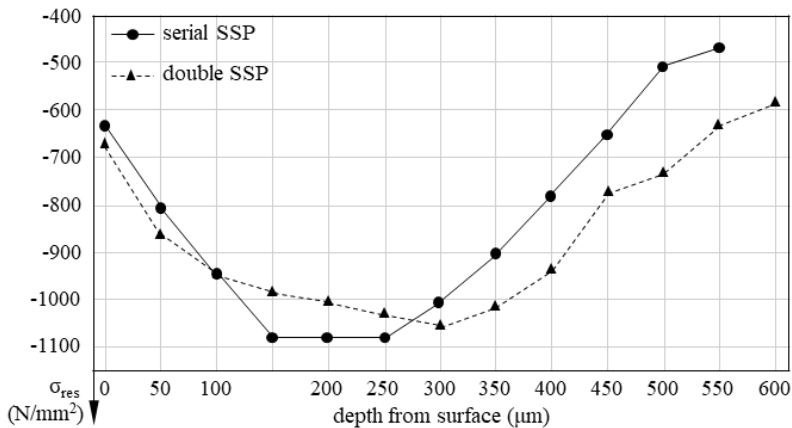

Fig. 3. Residual stress and micro-hardness distributions over depth from surface for the serial and double SSP specimens.

Both states, either serial or double SSP, seem to be almost indistinguishable concerning the aspects presented in the Figure above. Any small differences noticed may easily be attributed to the slightly higher decarburization of the optimized SSP specimen, which also agrees with the translation of the peak stress of the optimized SSP process towards a deeper region. This behaviour can be explained by the fact that less energy is required to plastify the softer surface layers in this case, leaving a larger amount of momentum to travel deeper into the material. Considering this later condition, no difference can be interpreted by the comparison of the two specimens.

The characteristic macro-hardness values ranging between the narrow band of 46 to 48 HRC is also in line with the core materials' strength measured at all three states of HTT, serial SSP and double SSP, while the roughness parameters R_a (6.5-7 μ m) and R_z (32-42 μ m) usually associated with durability, do not seem to differentiate themselves between the two peened states. It is noted that the later finding is expected since the peening conditions are identical during the second pass of the double SSP state.

2 Fatigue testing and fatigue life results

The fatigue testing was performed using servo-hydraulic test rigs specifically designed for this purpose, according to the requirements for support and loading shown in Figure 1. At least 15 to 20 tests were conducted for each state (HTT, serial SSP and double SSP) and each stress ratio ($R=0$ and $R=0.5$) giving a total of 6 fatigue live curves. The respective parameters were allocated using the typical regression statistical tools as well as the dictated minor adjustments according to experience, mainly in terms of identification of knee-points of the curves. The resulting scatter-bands reflect a typical standard deviation of fatigue tests close to $T_N=1:2$ for almost all cases between the probabilities of survival $P_s=90\%$ and $P_s=10\%$.

2.1 Fatigue testing

Figure 4 exemplarily illustrates one of the fatigue test rigs used for the experimental determination of the fatigue life curves. The supports on both sides consist of $\varnothing 50$ mm cylinders that are frequently greased to minimize friction in the contact area. The load is inserted by an actuator which is fixed to the vertical direction that pulls down either one or (in this case) two specimens simultaneously with the desired force magnitude. This way the time-related capacity of the test rig is doubled.

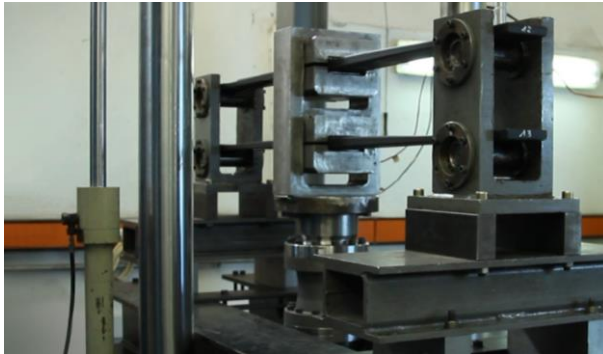

Fig. 4. Fatigue test rig for leaf specimen testing according to the drawing requirements (see Fig. 1).

2.2 Fatigue life results and mean stress sensitivity factors

Figure 5 illustrates the fatigue life results and respective S-N curves determined for each condition (HTT, Serial SSP and Optimized SSP respectively). It is noted that the results close to the fatigue limit or invalid premature fractures are excluded from further analysis through statistical tests, e.g. Dixon's Q test for outliers [3].

The S-N curve slopes, k , and the fatigue life scatter bands T_N are clearly indicated therein. It is evident that there is a noticeable knee point around $2\cdot 3\cdot 10^5$ cycles for all S-N curves at the stress ratio $R=0$, which is translated around the area of 10^5 cycles at $R=0.5$. The influence of serial SSP is clearly pronounced when compared to the HTT condition, offering a 60-70%

increase in allowable maximum stress as expected. Additionally, there is a further increase of the fatigue life between the serial and double SSP by a factor of about 1.5-2.1.

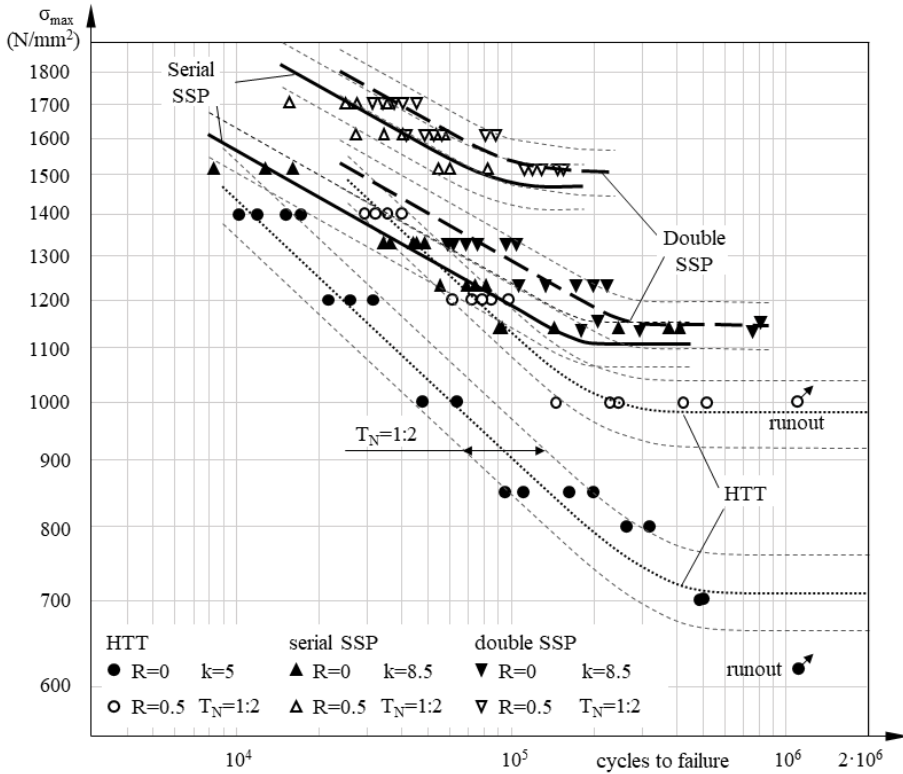

Fig. 5. Fatigue life (S-N) curves, slopes and respective scatter-bands for the HTT, serial SSP and double SSP states.

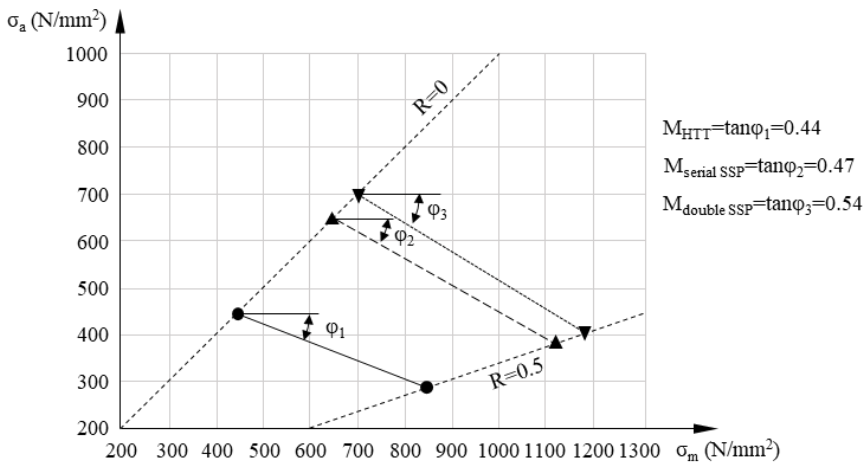

Fig. 6. Haigh diagram and mean stress sensitivity factors for the HTT, serial SSP and double SSP states, $N=10^5$ cycles.

Finally, the Haigh diagram and respective mean stress sensitivity factors are presented in Figure 6 for a design-characteristic number of cycles-to-failure $N=10^5$. Given that the slopes between R=0 and R=0.5 for each condition do not change significantly, it is deduced

that neither the mean stress sensitivity factors will exhibit deviations at different number of cycles-to-failure. Hence, the mean stress sensitivity factors determined are valid for all number of cycles in the finite fatigue life region covered here with test results. Nevertheless, it is shown that the increase in fatigue life always comes at the cost of an increased mean stress sensitivity when the three conditions are compared to each other, a finding which also agrees well with the common knowledge and experience [4].

3 Summary and conclusions

A thorough and comprehensive study of the fatigue life of leaf specimens has been carried out covering all major production stages, i.e. the HTT, serial SSP and double SSP conditions. A total of six fatigue life curves have been determined alongside all relevant statistical data able to fully describe the fatigue life behaviour for the operational-relevant stress ratios of $R=0$ and $R=0.5$. Finally, the mean stress sensitivity factors between these ratios have been also quantified.

All findings are qualitatively in line with the theoretical background, enabling the deduction of useful quantitative conclusions for the behaviour of the 51CrV4 high-strength steel alloy, which has been systematically studied for the first time hereby. The slopes and scatter-bands of the fatigue life curves also agree with the current know-how and experience, while new evidence have appeared regarding the fatigue limit positioning around the area between 10^5 and $2 \cdot 10^5$ cycles instead of the $5 \cdot 10^5$ cycles estimated until now.

The surface state (roughness and residual stress distribution) does not seem to change significantly when the peening time is doubled, but at the same time, the fatigue life is almost decisively increased. This experimental fact is attributed to the actual coverage increase of the double peening time, which when combined with the weakest-link approach, seems to leave (from a statistical point of view) less areas prone to premature failure due to inadequate residual stresses. The later deduction is actually one of the most useful and practical conclusions of the present investigation, since it indisputably demonstrates the need for the leaf spring manufacturing industry to reconsider its current practices and step towards a new equilibrium between costs and performance enhancement of its products.

This project has received funding from the Research Fund for Coal and Steel under grant agreement No 799787 (LIGHTTECH project acronym). The authors would like to gratefully acknowledge the Research Fund Coal and Steel.

References

1. EN 10092-1:2004, *Hot rolled spring steel flat bars - Part 1: Flat bars - Dimensions and tolerances on shape and dimensions*
2. SAE J2277, *Shot Peening Coverage Determination*, SAE International, 2013.
3. R. Dean and R. Dixon, *Simplified Statistics for Small Numbers of Observations*, Anal. Chem., vol. 23, no. 4, pp. 636-638, (1951)
4. W. Schütz, *Über eine Beziehung zwischen der Lebensdauer bei konstanter und bei veränderlicher Beanspruchungsamplitude*, Zeitschrift für Flugwissenschaften, vol. 15, no. 11, pp. 407-417, (1967)