



D4.2 DISCRETE EVENT SIMULATION FORMALISM FOR PRODUCTIVE, RESOURCE EFFICIENT, AND SAFE CONSTRUCTION PLANNING

[Manuel Jungmann, TUB]

@AshvinH2020 
ASHVIN H2020 Project 
www.ashvin.eu 



ASHVIN has received funding from the European Union's Horizon 2020 research and innovation programme under Grant Agreement No 958161. This document reflects only the author's view and the Commission is not responsible for any use that may be made of the information it contains.

Project Title	Assistants for Healthy, Safe, and Productive Virtual Construction Design, Operation & Maintenance using a Digital Twin
Project Acronym	ASHVIN
Grant Agreement No	958161
Instrument	Research & Innovation Action
Topic	LC-EEB-08-2020 - Digital Building Twins
Start Date of Project	1st October 2020
Duration of Project	36 Months

Name of the deliverable	Discrete event simulation formalism for productive, resource efficient, and safe construction planning
Number of the deliverable	D4.2
Related WP number and name	WP 4 Control and real-time simulation of construction
Related task number and name	T4.2 Real-time discrete event simulation
Deliverable dissemination level	PU
Deliverable due date	30-09-2022
Deliverable submission date	30-09-2022
Task leader/Main author	Manuel Jungmann (TUB)
Contributing partners	Timo Hartmann (TUB)
Reviewer(s)	Ellen Göransson, Rogier Jongeling, Philip Nathorst-Westfelt (PlanB); Christina Claeson-Jonnsson (NCC); Joan Evelyn Ongodia (TUB); Rahul Tomar (DTT)

ABSTRACT

This deliverable summarises the results of task 4.2 *Discrete event simulation formalism for productive, resource-efficient, and safe construction planning*. The purpose of this document is to explain how the developed approach can be used to apply data-driven, real-time discrete event simulation during construction execution to manage the ongoing production processes. In close alignment to three demonstration cases of the ASHVIN project, frequently used work process patterns were determined. Derived from the construction work process patterns, discrete event system specification formalisms were developed. During the production process, raw data were gathered in real-time. These collected data were analysed to gain information and knowledge by artificial intelligence about the as-built product and the as-performed process. In particular, activity durations are determined, which

are used within stochastic productivity modelling to determine suitable probability density functions. These probability density functions are input for the activity durations in the modelled discrete event simulation. The developed discrete event simulation mechanisms can account for supply-chain logistical, resource-dependent, and spatial characteristics of the respective construction site. Additionally, disturbances by weather conditions or during material deliveries can be considered. After successful calibration of the model, different construction options are compared by the data-driven discrete event simulation in consideration of Lean Construction principles according to automatically calculated productivity, resource efficiency, and safety-related key performance indicators. Thus, the improvement of future supply-chain logistics, resource allocations, and site layouts can be enabled based on current representations of construction sites as digital twins.

KEYWORDS

Digital twin, Digital twin construction, Discrete event simulation, Discrete event system specification, Real-time data

REVISIONS

Version	Submission date	Comments	Author
V0.1	04.08.2022	Draft	TUB
	02.09.2022	Review	PlanB; NCC; TUB
V0.2	16.09.2022	Revision	TUB
	24.09.2022	Final review	DTT
V1.0	30.09.2022	Submission	TUB

DISCLAIMER

This document is provided with no warranties whatsoever, including any warranty of merchantability, non-infringement, fitness for any particular purpose, or any other warranty with respect to any information, result, proposal, specification or sample contained or referred to herein. Any liability, including liability for infringement of any proprietary rights, regarding the use of this document or any information contained herein is disclaimed. No license, express or implied, by estoppel or otherwise, to any intellectual property rights is granted by or in connection with this document. This document is subject to change without notice. ASHVIN has been financed with support from the European Commission. This document reflects only the view of the author(s) and the European Commission cannot be held responsible for any use which may be made of the information contained.

ACRONYMS & DEFINITIONS

AI	Artificial intelligence
AIC	Akaike-Information Criterion
AEC	Architecture, engineering, and construction
BIC	Bayesian-Information Criterion
BIM	Building Information Modelling
CMT	Configuration management tool
CSV	Comma-separated values
DES	Discrete event simulation
DEVS	Discrete event system specification
DT	Digital twin
DTC	Digital twin construction
ECDF	Empirical cumulative distribution function
EIC	External input coupling
EOC	External output coupling
EU	European Union
GPS	Global positioning system
IC	Internal coupling
IoT	Internet of things
IMU	Inertial measurement unit
JIT	Just in time
JSON	JavaScript Object Notation
KPI	Key performance indicator
KS test	Kolmogorov-Smirnov Test
LBS	Location breakdown structure
MLE	Maximum likelihood estimation
M&S	Modelling and Simulation
PDF	Probability density function
PDSA	Plan-Do-Study-Act
PI	Performance indicator
R&D	Research and development
WBS	Work breakdown structure

wh	Working hour
----	--------------

ASHVIN PROJECT

ASHVIN aims at enabling the European construction industry to significantly improve its productivity, while reducing cost and ensuring absolutely safe work conditions, by providing a proposal for a European wide digital twin standard, an open source digital twin platform integrating IoT and image technologies, and a set of tools and demonstrated procedures to apply the platform and the standard proven to guarantee specified productivity, cost, and safety improvements. The envisioned platform will provide a digital representation of the construction product at hand and allow to collect real-time digital data before, during, and after production of the product to continuously monitor changes in the environment and within the production process. Based on the platform, ASHVIN will develop and demonstrate applications that use the digital twin data. These applications will allow it to fully leverage the potential of the IoT based digital twin platform to reach the expected impacts (better scheduling forecast by 20%; better allocation of resources and optimisation of equipment usage; reduced number of accidents; reduction of construction projects). The ASHVIN solutions will overcome worker protection and privacy issues that come with the tracking of construction activities, provide means to fuse video data and sensor data, integrate geo-monitoring data, provide multi-physics simulation methods for digital representing the behaviour of a product (not only its shape), provide evidence based engineering methods to design for productivity and safety, provide 4D simulation and visualisation methods of construction processes, and develop a lean planning process supported by real-time data. All innovations will be demonstrated on real-world construction projects across Europe. The ASHVIN consortium combines strong R&I players from 9 EU member states with strong expertise in construction and engineering management, digital twin technology, IoT, and data security / privacy.

TABLE OF CONTENTS

1	INTRODUCTION	9
1.1	Purpose and Intended Audience.....	9
1.2	Distinction from Existing Market Solutions	10
1.3	Outline	11
2	LITERATURE BACKGROUND	11
2.1	Construction Work Process Pattern	11
2.2	Modelling and Simulation	11
2.3	Discrete Event Modelling and Simulation.....	13
2.3.1	Discrete Event Simulation	13
2.3.2	Discrete Event System Specification	14
2.4	Real-Time Data and Digital Twins	16
2.5	Stochastic Modelling.....	19
2.5.1	Probability Density Functions.....	19
2.5.2	Probability Density Estimation	21
2.5.2.1	Hypothesis testing	21
2.5.2.2	Information criteria	22
2.6	Key Performance Indicators	22
2.7	Calibration.....	23
3	ASHVIN DISCRETE EVENT FORMALISMS.....	23
3.1	Overall Framework	23
3.2	ASHVIN Construction Work Process Patterns	25
3.3	Stochastic Productivity Modelling Based on Real-Time Data.....	25
3.4	Probabilistic Disturbance Modelling	28
3.5	ASHVIN Key Performance Indicators.....	28
3.5.1	Total Duration.....	29
3.5.2	Productivity Rate	29
3.5.3	Utilisation Rate of Equipment	29

3.5.4	Number of Concurrent Trades	29
3.5.5	Safety Factor	30
3.5.6	Costs for Equipment and Workers	30
3.6	Calibration of DES models	30
4	DES SUPPORTED LEAN PLANNING AND OPTIMISATION.....	32
4.1	Optimised Supply Chain	32
4.2	Optimised Resource Allocation.....	32
4.3	Optimised Site Layout	33
5	DISCRETE EVENT SIMULATION MECHANISMS	33
5.1	#4 Rinteln: Mounting of Prefabricated Columns.....	34
5.1.1	#4 Industrial building in Rinteln, Germany.....	34
5.1.2	Challenges and Rationale	34
5.1.3	Modelling of DES Mechanism.....	35
5.1.4	Real-time data collection.....	37
5.1.5	Stochastic Productivity Modelling	37
5.1.6	KPI Calculation	39
5.1.7	Calibration	40
5.1.8	DES Supported Lean Planning and Optimisation.....	41
5.2	#5 Gothenburg: Finishing Works.....	43
5.2.1	#5 Kineum Office/Hotel building in Gothenburg, Sweden.....	43
5.2.2	Challenges and Rationale	43
5.2.3	Modelling of DES Mechanism.....	44
5.2.4	Real-time data collection.....	46
5.2.5	Stochastic Productivity Modelling	46
5.2.6	KPI Calculation	47
5.2.7	Calibration	47
5.2.8	DES Supported Lean Planning and Optimisation.....	48
5.3	#6 Barcelona: Concrete Works by Crane	50
5.3.1	#6 Office building in Barcelona, Spain.....	50
5.3.2	Challenges and Rationale	51
5.3.3	Modelling of DES Mechanism.....	51
5.3.4	Real-time data collection.....	54
5.3.5	Stochastic Productivity Modelling	54
5.3.6	KPI Calculation	56
5.3.7	Calibration	56
5.3.8	DES Supported Lean Planning and Optimisation.....	58

6	DISCUSSION	60
7	REFERENCES	62

INDEX OF FIGURES

Figure 1:	Basic entities in M&S and their relationships	12
Figure 2:	Comparison of continuous versus discrete event simulation	13
Figure 3:	DEVS atomic model semantics	15
Figure 4:	Coupled DEVS model	16
Figure 5:	Digital twin concept for the construction phase	18
Figure 6:	Uniform distribution and Triangular distribution	19
Figure 7:	Normal distribution and Lognormal distribution	20
Figure 8:	Logistic distribution and Gamma distribution	20
Figure 9:	Cauchy distribution and Weibull distribution	20
Figure 10:	Two-sided hypothesis test	21
Figure 11:	Overall framework for real-time DES	24
Figure 12:	Procedure for determining PDFs	26
Figure 13:	Comparison of an ECDF and a normal distribution function	27
Figure 14:	Procedure for Wilcoxon-signed-rank test	31
Figure 15:	Visualisation industrial building in Rinteln, Germany (SN-online 2021)	34
Figure 16:	DEVS model for mounting prefabricated columns	35
Figure 17:	Time-lapsed images from Rinteln construction site (Goldbeck 2021)	37
Figure 18:	Resulting durations of the Monte-Carlo method #4 Rinteln	41
Figure 19:	Visualisation on the ASHVIN platform #4 Rinteln	43
Figure 20:	#5 Kineum building in Gothenburg, Sweden	43
Figure 21:	Coupled DEVS model for finishing works	44
Figure 22:	DEVS submodel for dry wall works	45
Figure 23:	#5 Gothenburg – Option 3 - Workspace 1 and Workspace 3 usage	49
Figure 24:	Visualisation of the DES results on the ASHVIN platform #5 Gothenburg	50
Figure 25:	Visualisation #6 Office building in Barcelona, Spain	50
Figure 26:	Coupled DEVS model for concrete works by a crane	52
Figure 27:	DEVS submodel for concrete works	53
Figure 28:	Sensor mounting on the crane hook #6 Barcelona	54
Figure 29:	Resulting durations of the Monte-Carlo method #6 Barcelona	57
Figure 30:	#6 Barcelona – Option 1– Worker usage	59
Figure 31:	#6 Barcelona – Option 2 – Construction worker and street location usage	59
Figure 32:	#6 Barcelona – Option 3 –Street location and construction worker usage	60
Figure 33:	Visualisation on the ASHVIN platform #6 Barcelona	60

INDEX OF TABLES

Table 1:	Defining basic entities in M&S and construction examples	12
Table 2:	Real-time data collection technologies (adapted by Sacks et al. 2020)	17
Table 3:	Possible errors during hypothesis testing	22
Table 4:	Comparison demonstration sites and PIs	34
Table 5:	Settings for mounting of prefabricated columns	36
Table 6:	Durations for mounting columns	37
Table 7:	Comparison of possible PDFs for the mounting activity	38
Table 8:	Resulting PDFs for the mounting activity	38

Table 9: Comparison significance level and p-value for the mounting PDF	38
Table 10: Truck delivery durations for columns.....	39
Table 11: Comparison of possible PDFs for the delivery duration of columns	39
Table 12: Resulting PDF for delivery of columns	39
Table 13: Comparison significance level and p-value for the column's delivery PDF.....	39
Table 14: Resulting durations #4 Rinteln	41
Table 15: Wilcoxon-signed-rank test result #4 Rinteln, Germany	41
Table 16: Settings for construction options in the DES tool for #4 Rinteln	42
Table 17: Results for different options #4 Rinteln	42
Table 18: Activities and trades for finishing works	45
Table 19: Possible settings for finishing activities	46
Table 20: Resulting PDFs for the finishing work activities	46
Table 21: Settings for construction options in the DES tool for #5 Gothenburg.....	48
Table 22: Results for different options #5 Gotheburg.....	48
Table 23: Settings for concrete pouring by crane activity	53
Table 24: Concrete pouring activity durations	54
Table 25: Comparison of possible PDFs for Filling operation based on full data set.....	55
Table 26: Resulting PDFs for concrete pouring operations	55
Table 27: Comparison significance level and p-value for the Filling PDF based on the whole data set.....	55
Table 28: Resulting durations #6 Barcelona	57
Table 29: Wilcoxon-signed-rank test result #6 Barcelona.....	57
Table 30: Settings for construction options in the DES tool for #6 Barcelona	58
Table 31: Results for different options #6 Barcelona	58

1 INTRODUCTION

The architecture, engineering, and construction (AEC) sector faces fundamental problems. It is characterised by flat or even falling productivity rates (EURACTIV 2019) and it is the industry with the highest number of fatal and non-fatal accidents (Eurostat 2022) during the execution phase. One reason for this is the low level of digitalisation. In general, the construction field is one of the least digitalised sectors, although it is one of the economic, social, and environmental key industries in the European Union (EU). Digitalisation is accepted as a main driver to address issues such as productivity or resource efficiency (ESCO 2021). However, the management of construction is more complex in comparison to other industries. Dynamic and laborious interactions are performed outdoors under uncontrollable external circumstances, such as changing weather conditions. Efforts to incorporate digital technologies are emerging in the European construction sector to approach current shortcomings. It is agreed among public and private stakeholders that the digital twin (DT) concept – the creation of a virtual representation of a physical asset due to real-time data collection and its analysis – will have enormous potential for the future in AEC, but its usage is still very limited (ESCO 2021). Hence, the ASHVIN research project funded by the EU aims to address the present challenges to unlock the potential and increase the usage of the DT concept within the AEC industry.

To this end, this task of the ASHVIN project focuses on real-time discrete event simulation (DES) of processes during the construction phase. Real-time DES enables the simulation of construction site activities and the evaluation of their impacts on performance indicators (PIs) for productive, resource-efficient, and safe construction works. In close alignment with demonstration cases, work process patterns were determined to develop DES mechanism models. Discrete Event System Specification (DEVS) formalisms were created to build a basis for semantic understanding of each DES model. The DES mechanisms can account for supply-chain logistical, resource-dependent, and spatial characteristics of the site and can consume real-time DT data for managing ongoing construction works. The developed ASHVIN approach is based on the interaction and exchange of various tools, methods, and the ASHVIN platform, which functions as a database. Required interactions with other tools, methods, and the ASHVIN platform are mentioned, but the description of these is outside the scope of this deliverable.

1.1 Purpose and Intended Audience

This deliverable describes the developed procedure for real-time DES of construction processes and the application of the modelled formalisms. Hence, this report aims to promote the use of digitalisation and real-time data in the construction phase. The target audience for this deliverable consists of research and development (R&D) interested parties, professionals from the AEC sector, and software developers, who plan to apply the digital twin construction (DTC) paradigm – the proactive management of ongoing construction production based on DT usage – in the future for construction management. Additionally, it is aimed at informing project managers, construction companies, and public stakeholders about the possibilities of real-time data and the DT concept. This counts as well for small and medium-sized companies, which possibly do not have the resources for comprehensive R&D activities. Overall, the

purpose of this report is to increase understanding and awareness of digitalisation and DTs in the construction phase. Thus, this work provides an incentive for public and private construction and tech companies to initiate a digitalised transformation in the AEC sector.

1.2 Distinction from Existing Market Solutions

In current construction management, there is widespread usage of traditional scheduling tools, such as Microsoft Project, Primavera P6 or Powerproject, which are based on the critical path method. Within these approaches, the user cannot explore different construction options by simulation, although simulation is an effective method for construction management by revealing impacts on key performance indicators (KPIs) (Leite et al. 2016). Thus, in the initial planning phase, shortcomings already occur, as more efficient and cost-effective options would be possible. During the construction phase, these tools are unsuitable as they are based on historical information and not on current site conditions. Thus, it is complicated to investigate resource allocations and their impacts on construction execution.

In recent years, several start-ups and construction management software products have emerged on the market that offer Internet of Things (IoT) platforms for real-time data collection and information distribution. The ALICE technologies platform (ALICE Technologies Inc. 2022) enables project managers to test possible construction options and resource allocations prior to determination of the initial schedule and during construction works to improve the planning. Flair3D (Flair 3D 2021) is an online tool for sharing DT data among stakeholders. Additionally, simulation-based 4D process visualisations are possible. VISILEAN (VisiLean 2022) offers a collaborative planning workflow based on Lean principles with BIM. Scheduling is, however, based on the traditional software mentioned above and progress or other issues have to be reported by workers using an app. This reporting procedure also applies to other recent tools such as SINC (SINC 2022). In comparison to conventional, paper-based documentation, this is an advancement, but still insufficient, if considering the possible potential due to advanced digitalisation. BUILDOTS (Buildots 2022) uses artificial intelligence (AI) for analysing real-time data from 360-degree cameras and comparing it with a BIM file to track the progress and pace of work. The progress is integrated into the traditional scheduling software. These procedures are suitable to observe progress in a percentage planned complete chart and to detect deviations from planning. However, in all existing market solutions, real-time tracking is not used for data-based information gain, such as determination of productivity rates, and no data-based control actions are executed for ongoing management of works. So far, there is no data-based, real-time construction management tool available on the market that considers the complex, dynamic interactions by stochastics. As no reliable input data for activity durations are available, simulation results in unrealistic findings and DES is not used for construction planning and scheduling in practice so far. Hence, the developed approach as a real-time, data-based DES tool for improved, stochastic construction management is the first of its kind. For efficient planning, it is important to visualise problems during production at the earliest. Therefore, the 4D process visualisation of the DES tool is a useful addition. The proposed DES method is an innovative development beyond the state-of-the-art due to real-time data collection and its usage for data-based, stochastic DES for improved construction management.

1.3 Outline

The deliverable is structured as follows: The second section provides a basis for understanding stochastic DES and its formalisms. Additionally, the topics of real-time data and the DT concept are explained. In the following section, the envisioned framework for real-time DES and the connections between the DES and other ASHVIN methods are presented. The procedures for stochastic productivity modelling and KPI calculations are clarified. In the fourth section, it is described how the developed tool can facilitate Lean Construction by improving supply chains, resource allocations, and site layouts. Afterwards, three demonstration sites and the determined work process patterns are introduced. For each of the three work process patterns, a DEVS formalism was developed, and it is demonstrated how real-time DES can support Lean planning of ongoing construction works. Finally, the main contributions of this work and their practical value for construction management are emphasised and discussed.

2 LITERATURE BACKGROUND

2.1 Construction Work Process Pattern

In the AEC industry, it is common practice to divide the whole construction process into separate construction work process patterns. Process patterns are defined by describing the sequence of several activities by a particular construction method. A construction activity aims at completing a physical component or at performing support services by resources (Halpin and Riggs 1992). These work process patterns are used for planning and scheduling of construction works. As simulation modelling is an effective method for assisting construction management (Altaf et al. 2018), templates of work process patterns can be used in construction simulation to analyse various scenarios efficiently (König et al. 2012). Different attributes, such as productivity rates, material quantities, or the number of resources can be tested in a virtual environment by using generic, reusable templates of process patterns within simulation. Hence, work process patterns facilitate standardisation and configuration of construction sequences (Larsson et al. 2016).

2.2 Modelling and Simulation

Modelling and simulation (M&S) is an acknowledged technique for solving real-world engineering problems. In general, a model is used for simulation to facilitate the decision-making process. Zeigler et al. (1976; 2000; 2018) formulated a theory for simulation that is based on the general system theory and proposed an ontological framework for M&S (Figure 1). This approach can be described as the major theory in the simulation field (Sargent 2017). The framework clarifies basic entities – an object of interest in a system – and their relationships within M&S.

The basic entities of the M&S theory are the *source system*, the *experimental frame*, the *model*, and the *simulator*. In Table 1, the entities are defined and a level of system specification – a level of knowledge regarding the system's behaviour starting at 0 – is stated. For each entity, an example regarding M&S of construction processes is provided. The *source system*, or briefly *system*, is a real or virtual environment of interest. It can be seen as a source of observable data.

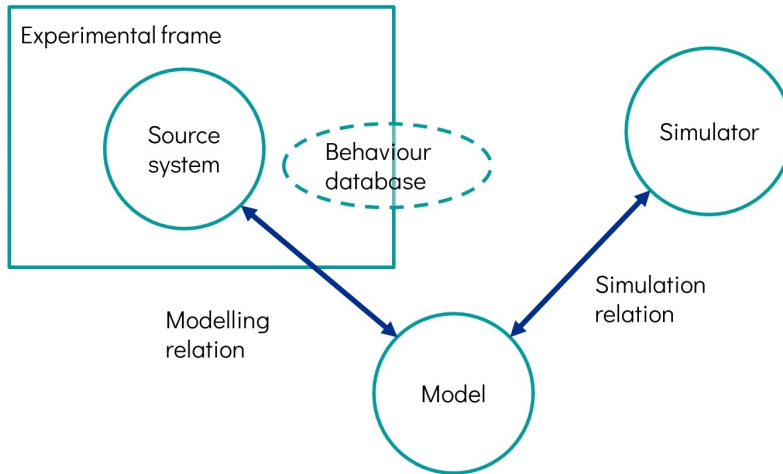

Figure 1: Basic entities in M&S and their relationships

Collected data from observation or experimentation of a *system* are called *behaviour database*. The *experimental frame* describes the *system's* conditions during observation or experimentation. Within the *experimental frame*, the matters of interest for M&S, e.g. influencing variables or outputs, can be determined. It is possible to formulate many *experimental frames* for the same *system* by choosing different influencing factors or outputs. A *model* outlines a set of instructions, rules, equations or constraints for generating input and output behaviour and can be described as a *system's* specification. A *model* receives input trajectories and generates output trajectories according to state transitions. Hence, it builds a mathematical foundation by defining an unambiguous *system's* semantics. Any computation system (e.g. a computer, human mind, etc.) can represent the *simulator* by executing a *model*. The *simulator* takes the set of instructions from the *model* and observes its behaviour.

Table 1: Defining basic entities in M&S and construction examples

Entity	Definition	Construction example	Level
Source system	Real or synthetic source of data	Physical construction site	0
Behaviour database	Collection of gathered data	Data collection during construction execution such as sensor data etc.	1
Experimental frame	Specification of system's specification during observation or experimentation	Specifications of number of resources or outputs such as duration etc.	3 and 4
Model	Instructions for generating data	DES model in computer software (e.g. in R)	3 and 4
Simulator	Computational device for generating system's behaviour	Computer	4

The basic interrelationships among entities are the *modelling relation* and the *simulation relation*. The *modelling relation* investigates whether a *model* is a valid representation of a *system*. The *simulation relation* defines the correct simulation of a *model* by a *simulator*.

2.3 Discrete Event Modelling and Simulation

2.3.1 Discrete Event Simulation

DES is a method for simulating real-world events in a virtual environment. Therefore, it presents a cost-effective and risk-free technique to model and analyse the effects of different management decisions on complex problems in an efficient way (Wainer 2009). Within DES, the process of listed, separated events is simulated over time. The system's state – representation of variables to describe the system's status related to the study's objectives – changes according to the occurrence of discrete events instead of continuously (Figure 2). The main outputs of a DES are duration and resource usage. As DES models and simulates processes, it is the appropriate simulation method, if focussing on operational level and management of complex construction interactions (Martinez 2010; Bokor et al. 2019).

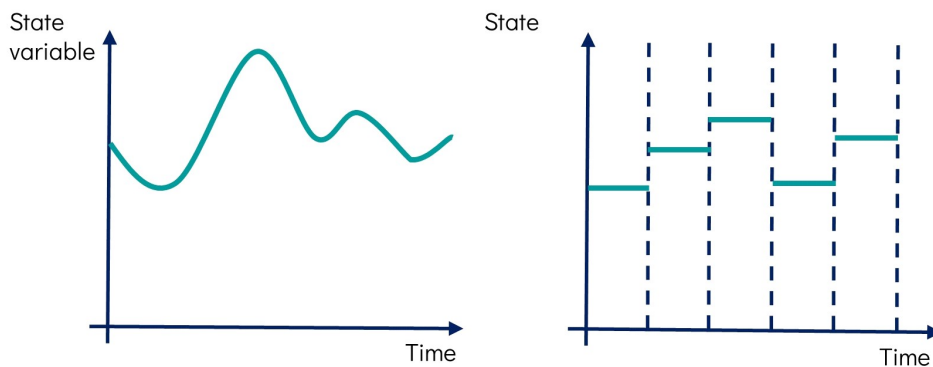

Figure 2: Comparison of continuous versus discrete event simulation

DES progresses for an event according to an activity duration and required resources are seized in the system. If needed resources are already seized for another activity, the activity has to wait in a queue for resources' release. DES can model either deterministic or stochastic systems (Behzadan et al. 2015). Stochastic approaches are the superior choice to present real-world simulations, as deterministic systems cannot consider randomness within simulation. Within the stochastic approach, activity durations are provided as probability density functions (PDFs) and the simulator chooses a variate accordingly. Thus, the occurrence of real-life dynamics can be modelled within DES. Additionally, it is possible to consider risks and uncertainties by stochastics for investigation of what-if analyses. The simulation finishes if no further events remain on the list, an end time is stated or a determined number of events have been simulated.

Construction works are frequently executed outdoors under uncontrollable conditions and are influenced by dynamics during execution, risks, and uncertainties. Changing weather conditions, congestion during material deliveries or other unpredictable events can affect the sequence of construction processes. Therefore, the application of DES is expedient for construction management by imitating construction operation sequences and resource allocations due to stochastics (Liu et al. 2015). DES has seldom been used in the AEC industry so far, although the benefits of the method are recognised (Behzadan et al. 2015; Abdelmegid et al. 2020; Rashid and Louis 2022).

2.3.2 Discrete Event System Specification

It is the first step of each M&S approach in construction research and practice to acquire knowledge about the logic and the sequence of activities (AbouRizk et al. 2011). Formalisms help decision-makers to understand how entities function and interact in DES of construction processes (Behzadan et al. 2015). However, formalisms are skipped regularly in all fields which results in invalid models (Wainer 2009). Therefore, research efforts regarding DES formalisms are essential for the application of DES in construction management (Abbasi et al. 2020).

Formalisms define the model of the M&S framework and can be understood as detailed definitions of systems' semantics. They describe simulation models by mathematical expressions and provide a basis for information exchange. Mapping the development of an idea helps to understand a system's complexities (Zeigler et al. 2018). Formal modelling enables improved verification, reuse, modification, and testing (Wainer 2009).

A widely used simulation formalism theory is DEVS originating from Zeigler (Zeigler 1976; Zeigler et al. 2000; 2018). DEVS is accepted within the model-based simulation research community (Zeigler 2011; Wainer and Mosterman 2016). The DEVS approach with ports based on Zeigler et al. (2000; 2018) is an advanced technique of the classic DEVS (Zeigler 1976), as a multitude of input and output ports can be established. In general, DEVS can consist of atomic and coupled models. Semantics of atomic models are defined in the basic formalism as

$$M = \langle X, Y, S, \delta_{int}, \delta_{ext}, \Lambda, ta \rangle$$

where

$X = \{(p, v) \mid p \in IPorts, v \in X_p\}$ is the set of input events, where $IPorts$ represents the set of input ports and X_p represents the set of values for the input ports;

$Y = \{(p, v) \mid p \in OPorts, v \in Y_p\}$ is the set of output events, where $OPorts$ represents the set of output ports and Y_p represents the set of values for the output ports;

S is a set of states;

$\delta_{int} : S \rightarrow S$ is the internal state transition function;

$\delta_{ext} : Q \times X \rightarrow S$ is the external transition function where

$$Q = \{(s, e) \mid s \in S, 0 \leq e \leq ta(s)\} \quad \text{is the total state set and}$$

e is the time elapsed since last transition;

$\Lambda : S \rightarrow Y$ is the output function; and

$ta : S \rightarrow \mathbb{R}_{0, \infty}^+$ is the time advance function;

with

$Q := \{(s, e) \mid s \in S, 0 \leq e \leq ta(s)\}$ is the set of total states.

Figure 3 displays an atomic DEVS model. At any given time, the system is in state $s \in S$. If no external event occurs, the DEVS model will stay in state s for time $ta(s)$. The time advance function ta can take any real value between 0 and ∞ . If $ta(s) = 0$, it is called a transient state, so that no external event can intervene. In the latter case, if $ta(s) = \infty$, s is in a passive state unless an external event interrupts it. When $ta(s)$

expires, the system outputs the value $\lambda(s)$ through a port $y \in Y$ and changes its state to $\delta_{int}(s)$. A transition due to time consumption stated by $ta(s)$ is termed as an internal transition. If an external event $x \in X$ occurs before expiration time, it is called external transition. The system changes to $\delta_{ext}(s, e, x)$, where s is the current state, x is the occurred external event as input, and e is the elapsed time the system is in the state due to x . Internal and external transitions proceed the system to a new state s' with resting time $ta(s')$.

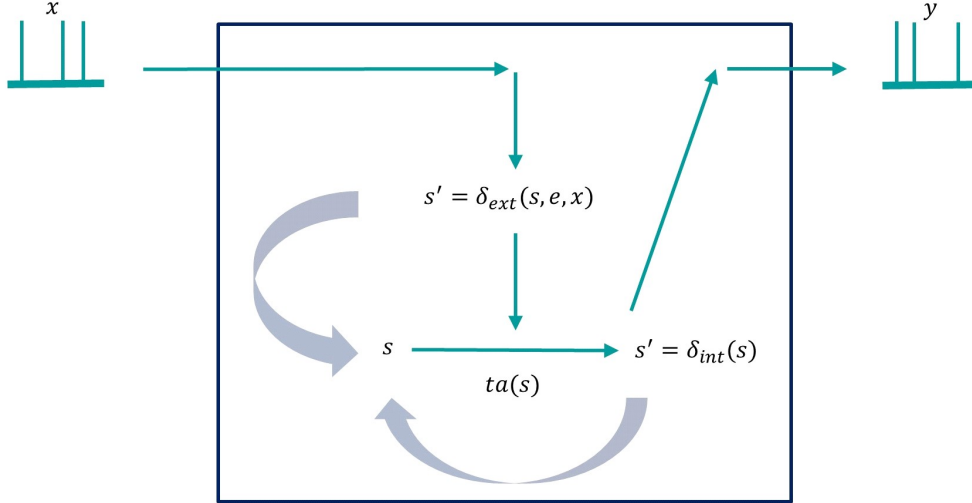

Figure 3: DEVS atomic model semantics

A coupled model consists of several atomic or coupled submodels and is formally defined in DEVS by

$$CM = \langle X, Y, D, M_d \mid d \in D, EIC, EOC, IC, select \rangle$$

where

$X = \{(p, v) \mid p \in IPorts, v \in X_p\}$ is the set of input events, where $IPorts$ represents the set of input ports and X_p represents the set of values for the input ports;

$Y = \{(p, v) \mid p \in OPorts, v \in Y_p\}$ is the set of output events, where $OPorts$ represents the set of output ports and Y_p represents the set of values for the output ports;

D is a set of components names;

M_d is a DEVS basic (i.e. atomic or coupled) model;

EIC is the set of external input couplings, $EIC \subseteq \{((Self, in_{self}), (j, in_j)) \mid in_{self} \in IPorts, j \in D, in_j \in IPorts_j\}$;

EOC is the set of external output couplings, $EOC \subseteq \{((i, out_i), (Self, out_{self})) \mid out_{self} \in OPorts, i \in D, out_i \in OPorts_i\}$;

IC is the set of internal couplings, $IC \subseteq \{((i, out_i), (j, in_j)) \mid i, j \in D, out_i \in OPorts_i, in_j \in IPorts_j\}$; and

$select$ is the tiebreaker function, where $select \subseteq D \rightarrow D$, such that nonempty subset E , $select(E) \in E$.

Figure 4 illustrates an example of a coupled DEVS model with the components A1, A2, and A3. A1, A2, and A3 are separate basic models. This means that they can be either

atomic or coupled models. The three basic models are interconnected by internal couplings (ICs). The output of the previous basic model functions as an input for the subsequent model. Hence, the output port of the previous basic model is connected to the input port of the subsequent basic model. The whole system has a general input port, which is connected to the input port of the first model. This is the external input coupling (EIC). The output of the last model's port functions as the external output coupling (EOC).

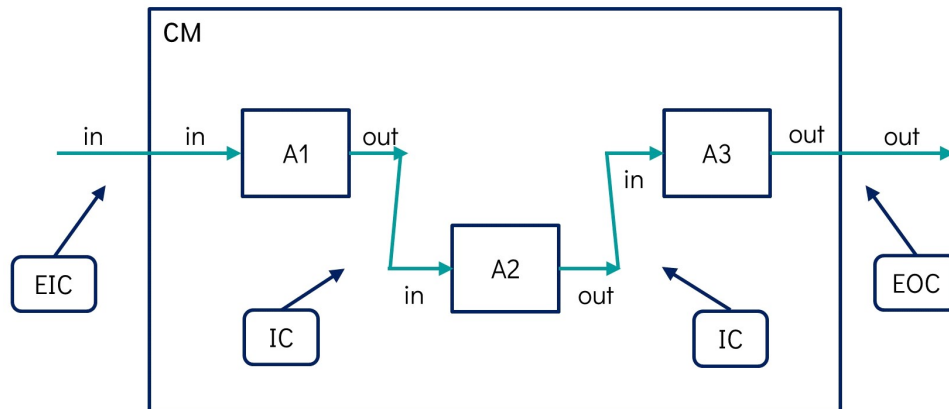

Figure 4: Coupled DEVS model

2.4 Real-Time Data and Digital Twins

The most influential aspects for the reliability of DES and its results are the input parameters, especially the provided activity durations (Banks et al. 2010). So far, static inputs are used for DES of construction processes, although DES enables inclusion of the dynamics during execution (Behzadan et al. 2015). The currently used inputs are based on empirical data or experience, which forms a barrier for large-scale usage of DES in the AEC sector (Lee et al. 2013). Each construction site has unique characteristics, which have to be noted within construction planning and scheduling. So far, some degree of adaptability has been considered in planning (Gao et al. 2014; Akhavian and Behzadan 2015), but when taking the complexity and differences between construction projects into account, conventional approaches are unsuitable to handle dynamic events and produce unrealistic results (Akhavian and Behzadan 2014; Abbasi et al. 2020). Deviations from initial planning occur regularly and schedules have to be revised according to current site conditions. Effective construction management requires the determination of deviations from the initial planning as early as possible (Seppänen et al. 2015) and information exchange among stakeholders (Hartmann et al. 2009). Detailed information about current site conditions and processes allows for production control and management actions (Roberts and Golparvar-Fard 2019). Thus far, deviations from initial planning and scheduling are stated delayed as no reliable, continuous control method is applied. There is a large gap between the ability of existing information systems and the potential benefits due to technological developments (Hartmann et al. 2009). Therefore, control actions are performed regularly too late to achieve the project's aims. To address this shortcoming, collecting real-time data automatically during construction works and gaining knowledge regarding current site processes is required (Akhavian and Behzadan 2013; Rashid and Louis 2022). This procedure provides meaningful input parameters

for DES models. Continuous data collection during construction execution and updates of input parameters are needed (Lee et al. 2013). Using data effectively for information gain to optimise construction operations is the next innovation challenge in the AEC industry (Bilal et al. 2016; ESCO 2021). Analysing resources during activities on construction sites by data enables improvements in productivity, resource-efficiency, safety, and quality of construction works (Wang et al. 2017; Cheng et al. 2018). In the past, data gathering of construction activities was time-consuming, labour-intensive, and error-prone (Xue et al. 2021). Due to current advancements in technology and automation such as the IoT – the connection of physical things, such as sensing devices or platforms, via internet for data exchange – real-time data collection is simplified. However, usage of technologies such as IoT is not widely adopted yet in the AEC sector as conventional approaches are still applied (ESCO 2021). Table 2 outlines key technologies for real-time data collection during construction works.

Table 2: Real-time data collection technologies (adapted by Sacks et al. 2020)

Technology	Hardware	Application
Electronic location and distance measurement	Laser scanning	Record current state of construction
Global positioning system (GPS)	GPS trackers	Equipment tracking; worker tracking; safety
Computer vision	Video, images	Production progress; safety
Audio and sonar	Microphones	Equipment function and usage
Tag identification systems	Radio-frequency identification, barcodes	Material tracking; worker tracking
Communication networks	Wi-Fi, ultra-wideband	Material tracking; worker tracking
Smart sensors and sensor networks	Velocity, acceleration, temperature, strain; IoT, edge computing	Equipment tracking; monitor construction quality; monitor safety

Collecting real-time data by different technologies on construction site enables to create a DT. The DT concept is still in its initial stage in the AEC industry and especially during the construction phase, the concept is rarely applied (Akanmu and Anumba 2015; Khajavi et al. 2019; Sacks et al. 2020; Deng et al. 2021), although it is expected that DTs promote smart construction (Jiang et al. 2021). According to Tao et al. (2019) a DT in the AEC industry is based on three key elements: the physical system, the digital model, and bidirectional links between both parts for data, information, and knowledge exchange based on advanced analytics technologies such as M&S, machine learning, and more. Collected data have to be analysed to update the digital model according to the physical system. As a DT must be used for a specific target service (Jiang et al. 2021), it is crucial to determine its purpose prior to its implementation (Brilakis et al. 2019). Therefore, the target service is another essential element of a DT.

A DT of a construction site can be used to manage construction processes. The use of a DT during construction for managing proactively ongoing production processes

while considering aspects such as Lean Construction is referred to as DTC. The physical system is the built asset, a construction site in the real world. The digital part is the digital model of the physical system. Data are gathered on the physical part, the behaviour database according to M&S, by data collection technologies and sent via internet to an IoT platform. The gathered data are used to gain project status information about the as-performed process and as-built product by AI. Additionally, the data and information, such as productivity rates, can be stored on a database for usage in future construction projects. Thus, the digital model must be regularly updated and can be used to compare the project status information with the intended as-planned process and the as-designed product. The results of the comparison are called project status knowledge (Sacks et al. 2020). Hereafter, the updated digital model can be used by M&S, such as DES, to test different future construction possibilities based on updated real-time data. This data-based information and knowledge can form the basis for planning meetings. The data, information, and knowledge exchanges enable proactive decision-making based on calculated KPIs according to the representation of the construction site as a DT. Figure 5 visualises the DT concept for the construction phase. The entire approach is based on the Plan-Do-Study-Act (PDSA) cycle for production management (Demming 1993). Due to the continuous data collection on site, it is aimed to learn and improve ongoing production processes.

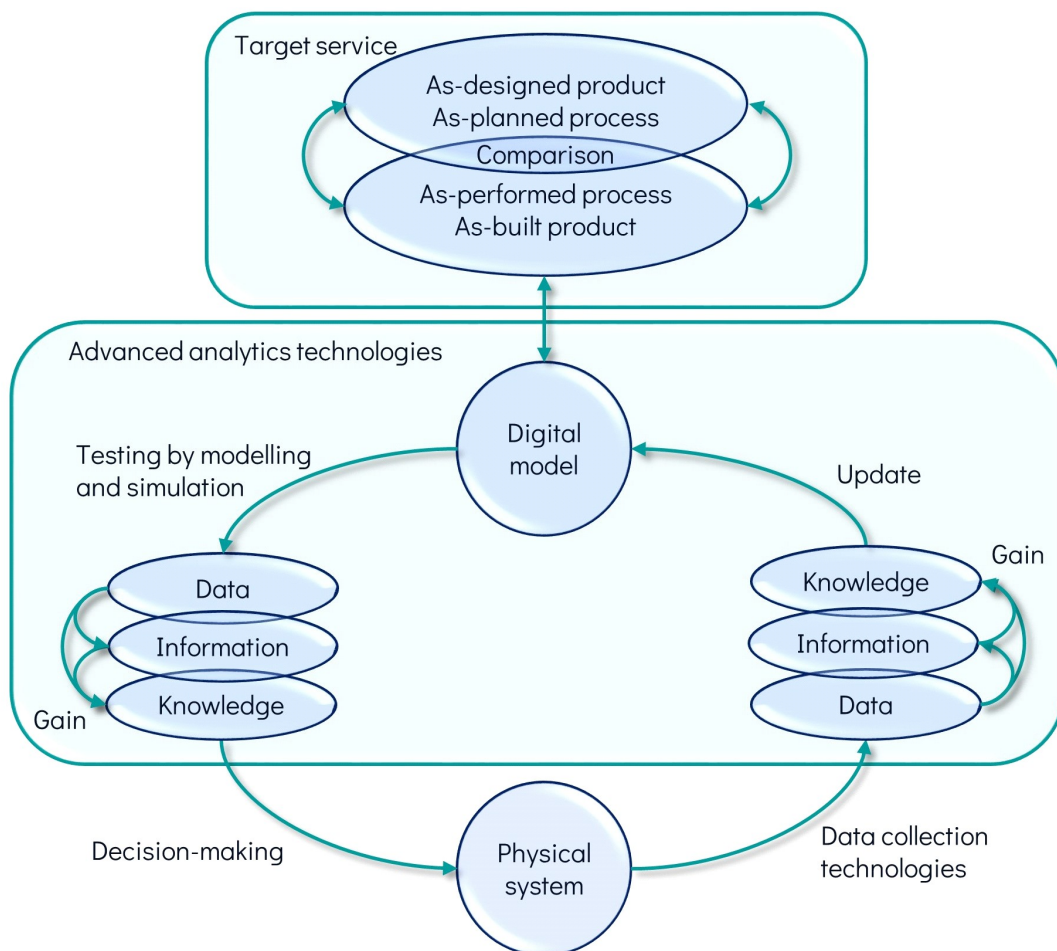

Figure 5: Digital twin concept for the construction phase

Research for real-time data collection and its automated linkage to DES is required (Alvanchi et al. 2021), as constant data-based updates of models during execution are essential for reliable decision-making (Rashid and Louis 2022). Due to continuous data collection in real-time, data-based activity durations can be determined and used subsequently for more meaningful simulations of construction processes. The seamless integration of real-time data enables data-driven DES and leverages technologies' possibilities.

2.5 Stochastic Modelling

2.5.1 Probability Density Functions

For stochastic DES, PDFs have to be provided as activity duration inputs. PDFs can be described as real-valued distributions of continuous variables. Probability distributions have different shapes and are described by appropriate parameters. Each continuous probability distribution can take an infinite number of possible values, but according to the PDF, a likelihood is provided that a variate falls within a certain range of values.

Hereafter, the within this deliverable, investigated probability distributions are described briefly and possible PDFs are visualised exemplary. The related parameters for each PDF are mentioned at the bottom of the visualisations. The uniform distribution is a symmetric PDF and is defined by a minimum and a maximum value. There is an equal probability for each value to occur between the bounds. The triangular distribution is described by the minimum, the mode, and the maximum. The corresponding distribution builds a triangle with these three points (Figure 6).

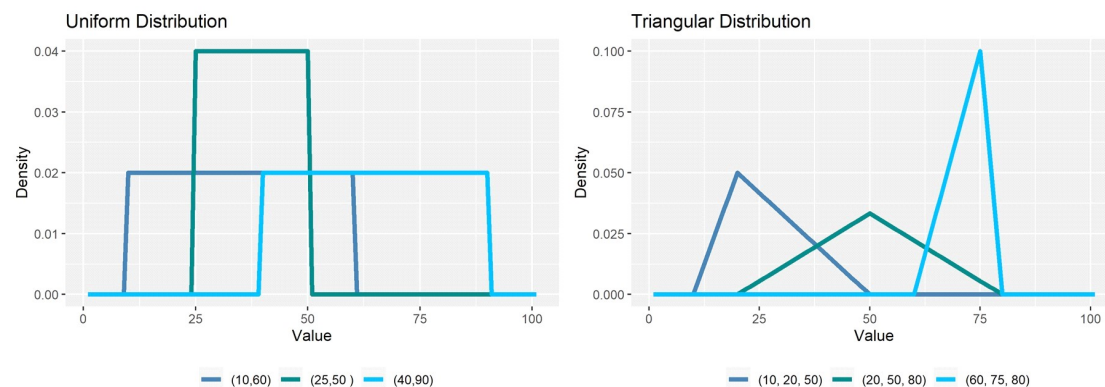

Figure 6: Uniform distribution and Triangular distribution

The normal distribution is a symmetric distribution defined by the mean, which is also the median and the mode, and a standard deviation. The higher the value of the standard deviation, the flatter and wider the curve. The lognormal distribution is a right skewed distribution and is characterised by the parameters mean log and standard deviation log. If the logarithm of the values of a lognormal distribution is taken, it results in a normal distribution. In reverse, if taking the exponential function of the values of a normal distribution, it results in the lognormal distribution (Figure 7).

The logistic distribution's shape resembles the normal distribution, but the tails are more emphasised. The logistic distribution is characterised by location and scale. The location determines the shift of the distribution and the scale is responsible for the spread of a distribution. The gamma distribution is characterised by the parameters'

shape and scale. It models the sum of exponentially distributed random variables (Figure 8).

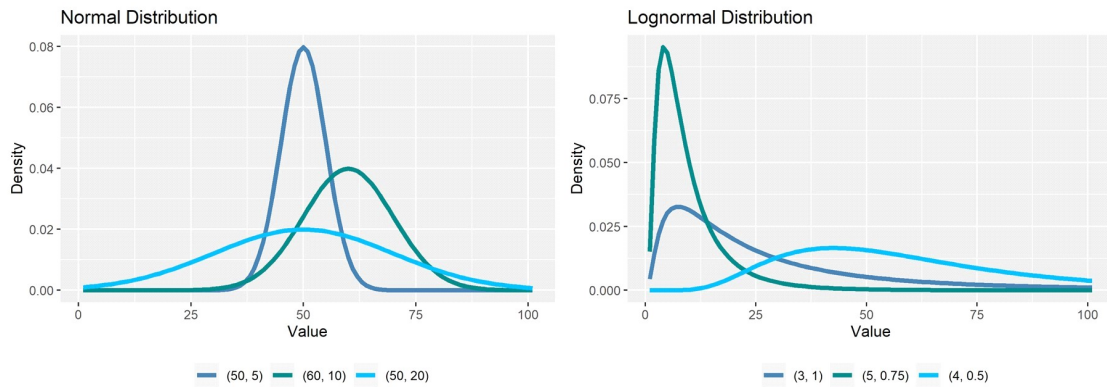

Figure 7: Normal distribution and Lognormal distribution

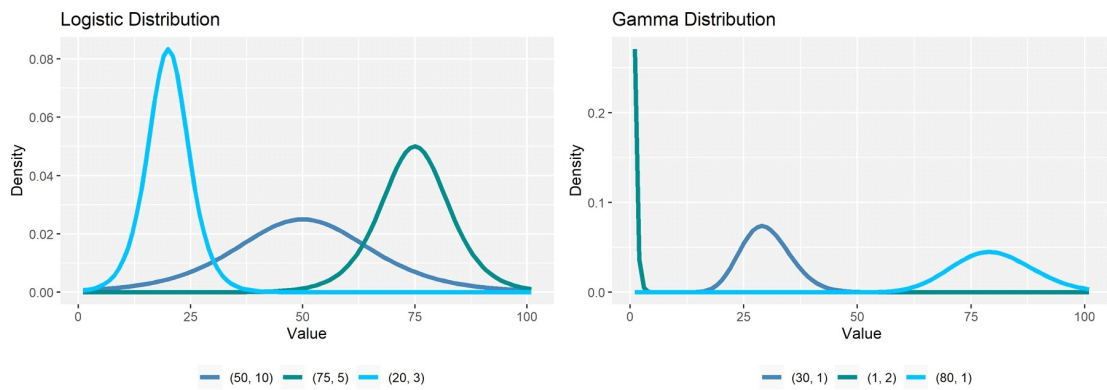

Figure 8: Logistic distribution and Gamma distribution

The Cauchy distribution is also described by the parameters' location and scale. It is similar to the normal distribution and the logistic distribution, but has a stronger kurtosis in comparison to the other distributions. The Weibull distribution is characterised by the parameters shape and scale. According to the parameters, it resembles the normal distribution or an exponential function. The Weibull distribution can represent left- and right-skewed data and is versatile useable due to its flexibility (Figure 9).

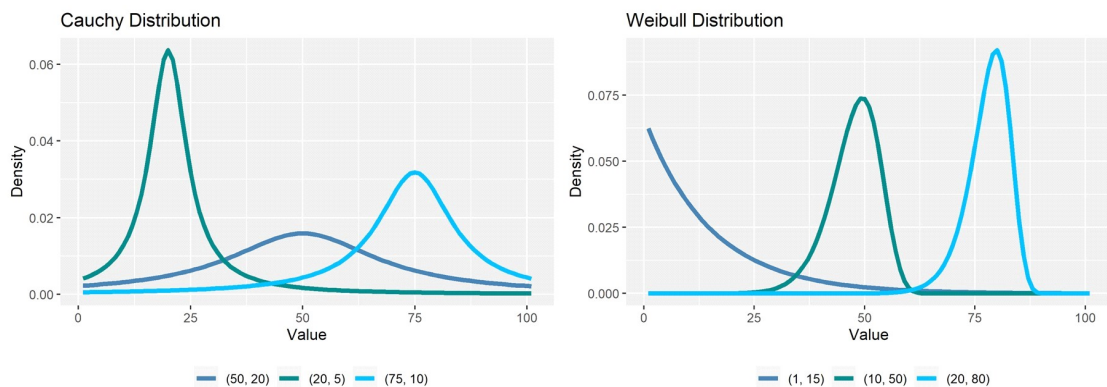

Figure 9: Cauchy distribution and Weibull distribution

For a deeper understanding of possible PDFs' characteristics see Thomopoulos (2018).

2.5.2 Probability Density Estimation

Probability density estimation is the procedure to determine suitable PDFs according to sample data. As possible PDFs never represent data exactly, the most suitable PDF has to be determined. For each possible distribution, the corresponding parameters have to be determined by maximum likelihood estimation (MLE) according to independent and identically distributed sample data. Within the MLE method, the likelihood function is maximised so that the input data x_i from n observations originate most probably from the PDF according to the determined parameters (Delignette-Muller and Dutang 2015). Subsequently, the PDFs are compared by one-sample Goodness-of-Fit techniques to determine the most suitable PDF. Goodness-of-Fit is a statistical method to investigate how well a distribution fits a given data set. In general, Goodness-of-Fit techniques can be distinguished into hypothesis tests and information criteria. It is recommended to apply several Goodness-of-Fit statistics simultaneously to a sample data set as each method can be unsuitable in some cases (Vincent 1998).

2.5.2.1 Hypothesis testing

Hypothesis tests calculate the difference between an empirical cumulative distribution function (ECDF) based on sample data and possible PDFs. If a PDF is determined by MLE, the actual hypothesis test has to be executed. The hypothesis test is a method of statistical inference to determine whether the model, the determined PDF, is a suitable representation of the sample data. A one-sample null hypothesis H_0 tests whether the sample with a size n of empirical data X comes from a PDF F_0 according to an in advanced stated significance level α and whether H_0 can be retained or has to be rejected. The null hypothesis H_0 assumes that the sample data of the ECDF $F_X(x)$ come from the determined PDF. If H_0 is not rejected, it does not mean that H_0 is true. This verifies only that there is not sufficient evidence against H_0 . Otherwise, the hypothesis H_0 is rejected for the two-sided alternative hypothesis H_1 , that n empirical data X do not come from the PDF F_0 . The alternative hypothesis H_1 detects a difference between the possible PDF and the sample data. Figure 10 depicts the concept of a two-sided hypothesis test.

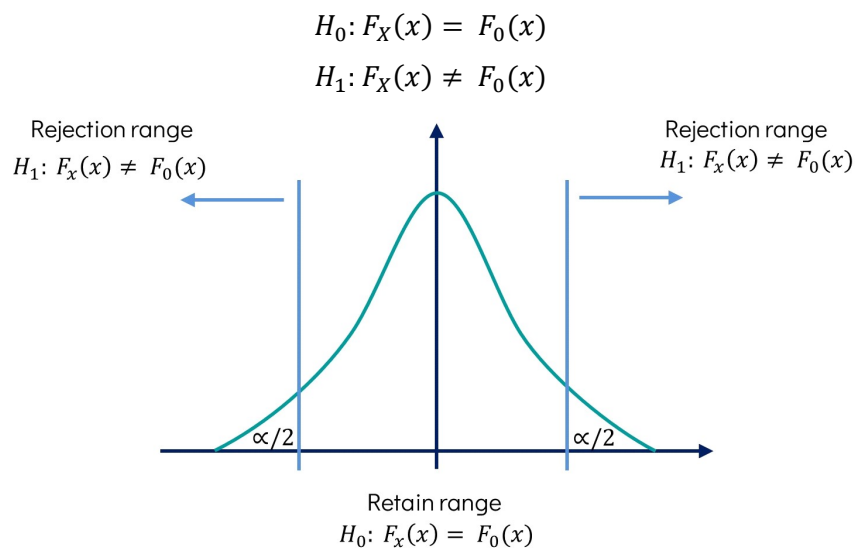

Figure 10: Two-sided hypothesis test

As only sample data are used for investigation, it is possible that the made decision is incorrect. Within hypothesis testing two possible errors could occur (Table 3). The significance level α is a fixed probability, which rejects H_0 , although it is in fact true. The significance level α stands for the type I error or false positive. A type II error occurs, also called β or false negative, if a false H_0 is not rejected.

The risks of errors can never be completely avoided, but increasing the sample size can reduce the probability of occurrence. A β error is influenced by the significance level α , as a lower significance level increases the risk of a beta error and vice versa. In the end, if a decision is made, it can be stated that the results are statistically significant at the significance level α .

Table 3: Possible errors during hypothesis testing

	H_0 is true	H_0 is false
Do not reject H_0	Correct decision	Type II error (β)
Reject H_0	Type I error (α)	Correct decision

As a next step, the p-value has to be calculated. The p-value corresponds to the probability of observing sample data at least as extreme as the actually obtained test statistic. In Figure 10, the p-value represents the two areas limited by the cross of the distribution and the x-axis and the vertical, light blue lines. Thus, the p-value provides a quantitative strength of evidence against the null hypothesis (Biau et al. 2010). The p-value calculation is based on α , n , the determined PDF, and the respective hypothesis test. The lower the p-value, the more unlikely the null hypothesis is. If the calculated p-value is below the in advance stated α , the null hypothesis must be rejected. Formally it can be described as:

$$\text{Do not reject } H_0, \text{ if } p > \alpha$$

$$\text{Do reject } H_0, \text{ if } p \leq \alpha$$

2.5.2.2 Information criteria

Information criteria estimate the information loss by a possible PDF according to the n sample data of a variable X . Information criteria compare only different, possible PDFs among each other for model selection and do not inform about the general quality of a model. Therefore, the hypothesis test does not have to be executed for information criteria. In general, it can be stated that information criteria are superior to hypothesis tests for the analysis of data in complex settings and are more powerful in exploratory data analysis where little a priori knowledge is available (Burnham and Anderson 2002).

2.6 Key Performance Indicators

The AEC industry and the execution of works have enormous impacts on economic, ecological, and social aspects. Construction processes are dynamic and difficult to predict. Many stakeholders with different intentions participate during the construction process. Therefore, a successful construction is ambiguous (Chan and Chan 2004). KPIs are used to determine goals for construction projects. It is important to state KPIs in advance. Well-defined KPIs help to estimate and measure the performance of construction progress. Additionally, KPIs support the control of processes and demonstrate gaps in construction planning. Within simulation, KPIs can be estimated

prior to construction execution and form the basis for the subsequent decision-making process.

2.7 Calibration

Calibration is the comparison of investigation values with known values. For M&S, this means the comparison of the simulated model results with the system. Thus, it is aimed to minimise the deviation of the simulated results from the real data, although it has to be considered that no model is able to completely represent a real system. Due to calibration, validation of a model can be achieved. Validation ensures that a model is an accurate representation of the system. By validation, confidence can be gained that the outputs of the model are useable for inferences regarding the real system under study. Validation is one of the most important and difficult tasks for model developers (Banks et al. 2010). A three-step process is widely accepted in research and practice for the validation of computer simulation models (Naylor and Finger 1967).

1. Step: Model validation

The first step is to observe the real system. Derived from the observations, a reasonable model that mimics the processes can be created. The model has to be improved continuously during development by calibration.

2. Step: Validation of model parameters

Model input parameters have to reflect reality. The input parameters, such as activity durations, can be derived from the collected data by applying AI in the form of data mining. The procedure during data collection could be recorded by video to validate the inputs.

3. Step: Input-output result comparison of the model and the real system

The final test of the model is the comparison of the model's prediction with the real system. Thus, the model's credibility can be derived. The model can be described as an input-output converter. Input parameters are used in the model, which converts these inputs to result outputs. If input parameters, such as activity durations, are changed, the model's result should represent the effects in the real system under similar circumstances.

3 ASHVIN DISCRETE EVENT FORMALISMS

3.1 Overall Framework

An overall framework for executing real-time DES of construction works was developed (Figure 11). First, a repetitive construction work process pattern has to be determined as the source system in close alignment with the demonstration case. In particular, repetitive processes are of interest as it is possible to continuously learn from the execution and apply this knowledge for the management of ongoing works. During construction execution of these work process patterns, real-time raw data are gathered by data collection technologies and sent via internet to the ASHVIN platform, which is developed in T1.1, to store the data in a database (Teodorović et al. 2020). Subsequently, data fusion and mining processes are applied to the collected data to derive information, i.e. activity durations, and store them on the ASHVIN platform. Afterwards, calibration has to be executed for the results of the data mining by comparing the determined durations with real values to obtain valid results. These

processes are described in D3.1 and D3.3 according to the respective data collection technology.

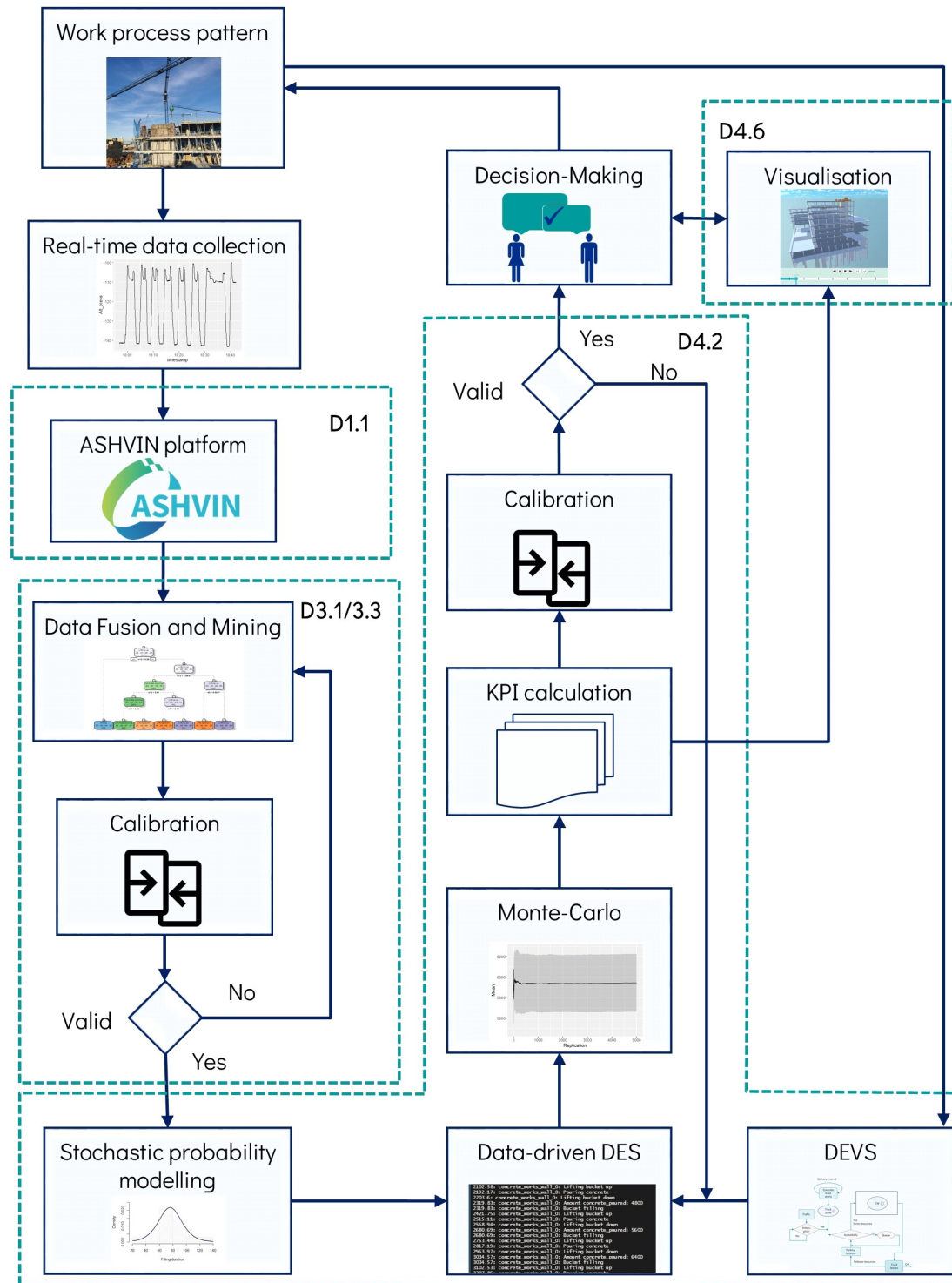

Figure 11: Overall framework for real-time DES

The resulting activity durations derived from the raw data are used for stochastic productivity modelling. Goodness-of-Fit is applied to determine suitable PDFs as production rates according to the sample data, the activity durations. Additionally, risks

during construction execution can be considered in the DES by probabilistic disturbance modelling. The determining of the PDFs could either be applied in addition to the processes described in D3.1 or D3.3, or another method for calculating the PDFs by accessing the activity durations on the ASHVIN database could be invented. This could be executed by edge computing to only save the activity durations and not the complete set of raw data on the database.

Based on the construction work process pattern, the DEVS formalism is created. Subsequently, the DES mechanism is derived from the DEVS in R software. The construction works can be structured by a work breakdown structure (WBS) and a location breakdown structure (LBS) according to Lean Construction as described in D4.3. Thus, there is a list of events that can be simulated by DES. The determined PDFs can be used by a random sampling approach as input parameters for stochastic, data-driven DES. Therefore, in T1.4 an API is proposed to access the PDFs on the ASHVIN platform for the DES. Because of the stochastic approach, the Monte-Carlo method has to be applied to receive reliable results. Within the DES model, PIs for productive, resource-efficient, and safe construction works are calculated, which were determined in D4.1 (Łukaszewska et al. 2021a). The DES model must be calibrated by comparing the resulting durations of the Monte-Carlo method with a real value to ensure the model's validity. If the calibration results in invalidation, the DES model has to be revised.

After successful validation of the model, the developed DES tool can be used to test different construction possibilities by changing supply chain logistics, resource allocations, and site layouts according to the respective construction site. Additionally, external conditions such as weather forecasts can be incorporated into the model to consider its impacts on construction execution. The PIs are calculated automatically for each option. These PIs form the basis for the decision-making process during the management of ongoing construction works. The results of the DES are provided as JavaScript object notation (JSON) files to the digital twin platform. The DES tool is combined with the configuration management tool (CMT), which is developed in T4.6, on the ASHVIN platform for visualisation purposes. Visualisations of the construction sequences support communication and understanding among stakeholders. When the project partners decide on a construction option, the works are executed accordingly and the whole procedure is repeated.

3.2 ASHVIN Construction Work Process Patterns

In ASHVIN, different construction work process patterns are determined in close alignment with the demonstration cases. It was aimed at choosing activities that are frequently used on construction sites. Thus, the reusability of the developed DES tool is ensured for future construction projects.

3.3 Stochastic Productivity Modelling Based on Real-Time Data

The determined activity durations based on real-time data are used within Goodness-of-Fit methods to approximate suitable PDFs as input parameters for stochastic DES of construction processes. The Kolmogorov-Smirnov test (KS test) and the chi-square test are the most common Goodness-of-Fit hypothesis tests, but the first one is more precise in comparison to the latter (Massey 1951). The Cramér-von Mises test and the Anderson-Darling test are in many cases even more powerful than the KS test. The

Anderson-Darling test gives more weight to the tails of distributions in comparison to other statistics, as it emphasises the tails and the main body of a distribution equally. If risks have to be considered, the Anderson-Darling test is of particular relevance (Stephens 1986).

The Akaike information criterion (AIC) and the Bayesian information criterion (BIC) are well-known information criteria and the usage of both is advisable. AIC predicts very well for a large sample size and can be considered as an approximately unbiased estimator for predicting accuracy (Bandyopadhyay and Forster 2011). The calculation of AIC and BIC is similar, but BIC aims to simplify the complexity of models by preventing overfitting (Delyette-Muller and Dutang 2015).

For all Goodness-of-Fit statistics, a low result is favoured as thus the PDFs reflect the collected data better. The following five Goodness-of-Fit methods were chosen to determine suitable PDFs:

- KS test (Hypothesis test)
- Cramér-von Mises test (Hypothesis test)
- Anderson-Darling test (Hypothesis test)
- AIC (Information criterion)
- BIC (Information criterion)

The general procedure for determining suitable PDFs as input parameters for DES by Goodness-of-Fit is presented in Figure 12. The steps 4. to 7. have to be executed only for the three hypothesis tests.

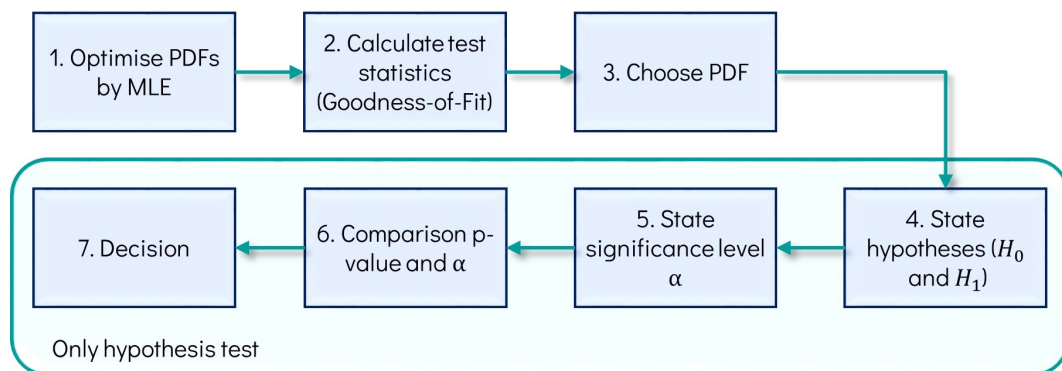

Figure 12: Procedure for determining PDFs

1. Optimise PDFs by MLE

For each of the presented distributions in section 2.5.1, the respective parameters have to be identified by optimisation through MLE according to the provided sample data – the determined activity durations of the construction activities.

2. Calculate test statistics (Goodness-of-Fit)

As a next step, the test statistics for the five Goodness-of-Fit measures have to be calculated. The possible PDFs are compared within the hypothesis tests with the sample data. The hypothesis tests take n empirical data of a variable X and sort them in ascending order to determine the ECDF $F_X(x_i)$. The created ECDF is compared to the possible PDF. The value of the possible PDF at x_i is calculated by $F_0(x_i)$. For each

$i = 1, \dots, n$ the largest vertical difference (D^-/D^+) between the ECDF and the possible PDF is calculated for the KS test (Figure 13).

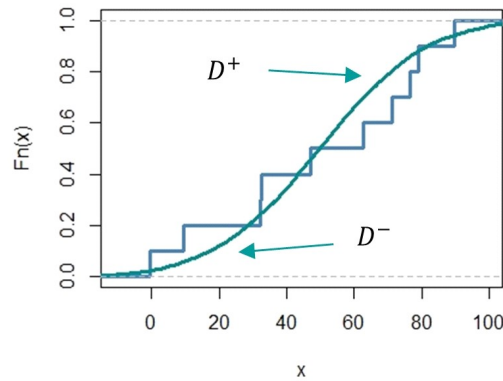

Figure 13: Comparison of an ECDF and a normal distribution function

The Cramér-von Mises test and the Anderson-Darling test are quadratic statistics as the distance between the ECDF and the possible PDF is squared. The calculation of both test statistics is similar distinguishing only by a different weighting function.

The information criteria AIC and BIC are based on the likelihood function. To avoid model complexity and overfitting, the number of parameters is considered as a penal term within the calculation (Delignette-Muller and Dutang 2015). On the one hand, it aims to achieve a high likelihood value for good model adjustment. On the other hand, as complex models with a high number of k achieve good adjustments, the number of parameters should be restricted to avoid too complex models. The BIC is calculated similar to the AIC, but the penal term has a higher influence for larger sample sizes.

3. Choose PDF

According to the results of the five test statistics, the PDF with the lowest results has to be chosen. If not all five test statistics prefer the same PDF, an overall ranking is calculated. For each test statistic a ranking for the PDFs is created. Finally, the rankings are summed up and divided by five, as there are five different Goodness-of-Fit statistics. Hence, the PDF with the best overall ranking can be chosen.

4. State hypotheses (H_0 and H_1) only for hypothesis test

The null hypothesis H_0 assumes that the determined activity durations X come from the determined PDF F_0 derived from the Goodness-of-Fit statistics. The alternative hypothesis H_1 supposes that the sample data, the activity durations, are not originated from the determined PDF.

$$H_0: F_X(x) = F_0(x)$$

$$H_1: F_X(x) \neq F_0(x)$$

5. State a significance level α .

6. Comparison significance level α and p-value

The p-value must be calculated for each hypothesis test separately. A detailed explanation of the p-value calculation for the KS test can be found in Marsaglia et al. (2003) and for the Cramér-von-Mises test and the Anderson-Darling test in Braun (1980). Subsequently, the calculated p-value is compared with the stated significance level α . If the p-value is equal or below the significance level, the null hypothesis has

to be rejected. Otherwise, if the p-value is above the significance level, it can be retained.

7. Decision

According to the results from the p-value calculation, it can be determined whether the null hypothesis has to be rejected or whether it can be retained. If the null hypothesis is not rejected, the determined PDF can be used as input for the activity duration in the data-driven DES.

3.4 Probabilistic Disturbance Modelling

As construction is executed outside under uncontrollable circumstances, risks can occur that disturb the construction process. For successful construction execution, it is necessary to identify causes of possible interruptions and to address these in planning. Besides poor coordination and improper planning, weather conditions and material shortages are determined as the main causes of construction delays (Durdyev and Hosseini 2020).

The AEC sector is one of the most sensitive industries according to adverse weather conditions (Alshebani and Wedatta 2014). Heavy wind or precipitation can lead to construction interruption, as for instance crane works have to be stopped because of safety aspects. In general, it is assumed that frequency and intensity of climate change will accelerate in the future (Moda et al. 2019). Therefore, it is beneficial to include weather forecasts into construction planning and the DES to circumvent the possible resulting shortcomings by adaptation of work coordination. Weather forecasts can be integrated, for instance as a comma-separated value (CSV) file containing hourly values, in the DES tool. Hence, the DES stops the construction process, if inappropriate conditions for execution are predicted.

The presence of materials is essential for constructing a physical facility. If a material shortage arises due to delayed material delivery, an interruption of construction processes occurs. To consider the risk of material shortage, the delivery period of material can be included in the DES tool. Data regarding the delivery durations of material can be collected and used for PDF calculations as described in section 3.3. The resulting PDFs for the delivery duration can be used as input parameters in the DES to determine suitable departure times for delivery vehicles.

3.5 ASHVIN Key Performance Indicators

The application of real-time DES for construction management enables improved construction planning and control of site activities by considering supply-chain logistic, resource-dependent, and spatial characteristics. For comparison and evaluation of construction possibilities, within D4.1 a set of KPIs for productive, resource-efficient, and safe construction works were defined (Łukaszewska et al. 2021a). Each KPI consists of several PIs. In the following sections, the relevant PIs and their calculations for the application of real-time DES of construction processes are explained. As the whole simulation is based on stochastic values, the Monte-Carlo method is applied to get reliable results. Therefore, for all PIs the median value according to the results of the Monte-Carlo method is chosen.

3.5.1 Total Duration

The construction duration is a crucial factor for the planning of sequences by DES and, thus, the total duration was added as a PI, although not listed in D4.1. The total construction duration is simulated automatically within the DES tool according to the input settings.

3.5.2 Productivity Rate

Productivity is a decisive factor for evaluating the success of construction projects. In general, productivity can be defined as the relationship between the produced output – e.g. the material quantity – and the used input – e.g. invested time by workers and equipment. The focus lies on the evaluation of efficiency and not the quality of executed works. The productivity rate is defined as:

$$\text{Productivity rate} = \frac{\text{Output}}{\text{Input}} = \frac{\text{Amount material}}{\text{whs}} \quad (1)$$

In the construction industry, the output is the amount of achieved work such as the quantity of poured concrete or number of mounted components. The productivity rate can be calculated for construction workers and equipment. Hence, the summed working hours of the resources – active and idle time – are taken as input, respectively for workers or the construction equipment.

3.5.3 Utilisation Rate of Equipment

Within the construction industry, much equipment is needed for a long time during construction works. However, heavy equipment is used inefficiently and, thus, overall construction productivity is influenced negatively (Slaton et al. 2020). The utilisation rate indicates the ratio of equipment being actively used to the total available time. Suboptimal coordination of works or allocation of resources results in idle times, which leads to higher costs. Furthermore, machines cause emissions which have negative ecological impacts on the environment.

The utilisation rate for construction equipment is calculated by summing up the active time for each heavy equipment divided by the sum of the active and idle time. Hence, the utilisation rate can be in a range from 0 to 100 %.

$$\text{Utilisation rate}_{\text{Construction equipment}} = \frac{\sum_{i=1}^n \text{Active time construction equipment}_i}{\sum_{i=1}^n \text{Active time} + \text{idle time construction equipment}_i} \quad (2)$$

3.5.4 Number of Concurrent Trades

Construction works are executed on a workspace frequented by several trades. Therefore, workers from different disciplines and equipment are moving on the construction site simultaneously. The occurrence of different trades at the same time on the same or adjacent area can lead to conflicts on construction site. The execution of works can be delayed due to hindrance among the trades and this can lead to hazardous situations for workers.

The PI number of concurrent trades is calculated by checking if different trades are working simultaneously on the same workspace. Within the DES tool, the period of stay at a location is simulated for all trades. Hence, it can be calculated how long several trades are located at the same workspace by the following equation:

$$\text{Concurrent trades} = \sum_{i=1}^n \text{Duration trade}_i \text{ at workspace}_i \quad (3)$$

, if number of trades at a defined workspace ≥ 2 .

3.5.5 Safety Factor

Due to a high number of equipment and workers on site executing different activities simultaneously, construction sites have dynamic properties. These entail high-risk and hazardous situations and complicate safety planning for construction works. It is aimed at reducing the probability of the occurrence of hazardous situations on construction sites to avoid accidents.

The safety factor is calculated context-specific for the work process patterns. For work process patterns, which require crane usage, the influence of wind during lifting activities is considered. The maximal allowed wind speed for crane operations can be dependent on national regulations or manufacturer recommendations. 20 m/s is a default value, but even if there is wind below 20 m/s it can lead to hazardous situations (Jin et al. 2020). Therefore, the time is calculated, when the crane is in an active state and the wind speed is in a certain determined range starting at a caution value, but the crane works do not have to be stopped because of exceeding a critical maximum value.

$$\text{Safety factor}_{Crane} = \sum_{i=1}^n \text{Activity time crane}_i \quad (4)$$

, if caution value \leq wind speed $<$ maximum value

3.5.6 Costs for Equipment and Workers

Costs are a central point within construction planning and can be a decisive aspect whether construction projects will be executed. The costs for equipment and workers during execution take a significant proportion of total construction costs. Circumstances such as suboptimal allocation of resources, idle times of machines or wrong delivery times of materials entail high, superfluous costs. By appropriate planning of construction works, the allocation of resources and supply chain can be optimised and, thus, the costs for resources can be reduced.

The costs for construction equipment and workers are calculated by summing up the active and idle time for each resource and multiplying it with the respective costs for the resources according to the demonstration site location.

$$\begin{aligned} \text{Total costs}_{\text{Equipment and worker}} &= \text{Costs for construction equipment}_i \\ &* \left(\sum_{i=1}^n \text{Active time} + \text{idle time}_{\text{equipment}_i} \right) \\ &+ \text{Costs for construction worker}_i \\ &* \left(\sum_{i=1}^n \text{Active time} + \text{idle time}_{\text{worker}_i} \right) \end{aligned} \quad (5)$$

3.6 Calibration of DES models

Within this deliverable, the focus is on step three of the calibration procedure presented in section 2.7. It is the testing of a model's overall validity by comparison with the

system according to M&S. The total duration resulting from the DES can be compared with the real duration of construction works in a distribution free hypothesis test. As stochastic DES is applied for calculation of the duration, the Monte-Carlo method has to be executed. The mean can be distorted by outliers and is, therefore, inappropriate for skewed distributions, whilst the median is more robust to outliers.

A two-sided hypothesis test has to be executed for the comparison of the real value and the model's median. The Wilcoxon-signed-rank test is a statistical hypothesis test, which can be used for the comparison of a fixed value – system's real value – and a sample's median – the results of the simulated model. It was proven in a multitude of simulation studies that the Wilcoxon-signed-rank test has greater statistical power and creates more statistically significant results in comparison to the widespread Student's t-test (Blair and Higgins 1980). The Wilcoxon-signed-rank test assumes symmetry around the median, although it does not demand a normal distribution. However, as the Monte-Carlo method is applied within the DES, the results tend to a normal distribution according to the central limit theorem. The general procedure for execution of the Wilcoxon-signed-rank test is based on Hollander et al. (2013) and can be described as follows (Figure 14):

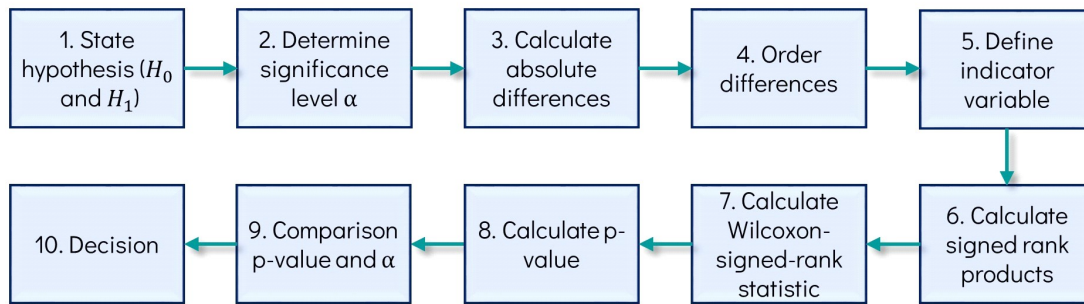

Figure 14: Procedure for Wilcoxon-signed-rank test

1. A null hypothesis and an alternative hypothesis have to be stated. The null hypothesis H_0 assumes that there is no significant difference between the median of the simulated data set and the real value. The alternative hypothesis H_1 rejects the null hypothesis and assumes a difference between the values:

$$H_0: \tilde{x}_1 = \tilde{x}_2$$

$$H_1: \tilde{x}_1 \neq \tilde{x}_2$$

with \tilde{x}_1 as the median of the DES and \tilde{x}_2 as the real duration.

2. State of the significance level α .
3. The calculation of the absolute values $|Z_i|, \dots, |Z_n|$ by the difference of the real duration \tilde{x}_2 and the n samples from the data set X_i, \dots, X_n .
4. Ordering the differences $|Z_i|, i = 1, \dots, n$ from smallest to largest.
5. Definition of the indicator variables $\psi_i, i = 1, \dots, n$, where

$$\psi_i = f(x) = \begin{cases} 1, & \text{if } Z_i > 0, \\ 0, & \text{if } Z_i < 0, \end{cases}$$

6. The calculation of the positive signed rank products $R_1\psi_1, \dots, R_n\psi_n$, where its value is equal to zero if Z_i is negative and equal to the rank $|Z_i|$ when Z_i is positive.

7. Calculation of the Wilcoxon- signed-rank statistic T as the sum of the positive-signed ranks by the following equation:

$$T = \sum_{i=1}^n R_i \psi_i. \quad (6)$$

8. Calculation of the p -value by an algorithm as described in Bauer (1972).
9. Comparison of the p -value to the determined significance level α . If the p -value results in higher value than the determined significance level α , the null hypothesis cannot be rejected. If the p -value is lower or equal to the significance level α , the null hypothesis has to be rejected.

Do not reject H_0 , if $p > \alpha$

Do reject H_0 , if $p \leq \alpha$

10. A decision has to be taken according to the comparison of the significance level and the p -value. If the equality of the real duration and the median cannot be rejected, the model is validated.

4 DES SUPPORTED LEAN PLANNING AND OPTIMISATION

4.1 Optimised Supply Chain

Supply chain management is still inefficient in the AEC sector (Heaton et al. 2022). In the construction industry, the supply chain consists of the following activities: procurement of raw materials, transformation of materials into finished products, and the distribution of these products to customers or construction sites (Ganeshan and Harrison 1995). The focus in the DES is on the distribution of construction components to the site. This phase is an essential aspect within construction planning, as, on the one hand, storage space is limited on construction sites and oversupplied material can lead to overcrowded sites. On the other hand, if the material is not delivered in a timely manner, idle time occurs for resources.

Thus far, there is limited communication and information exchange regarding the supply chain during the construction phase (Dallasega et al. 2018). To optimise the sequence of construction works, real-time DT data of ongoing processes and conditions on site are required. Based on this real-time information, the material deliveries can be adjusted to avoid idle time for resources and overcrowded sites. In the DES tool, it is possible to test different delivery options for optimising sequences. The change of the delivery interval, the quantity of delivered material or the delivery duration can be simulated in the DES tool to predict the respective impacts on the PIs.

4.2 Optimised Resource Allocation

In this deliverable, the term resource includes construction workers and equipment. The number of resources is limited on construction sites and efficient allocation is essential for project success regarding duration, costs, and productivity. Efficient management of resources can have further advantages such as positive environmental effects due to optimised usage of machines. However, the distribution of resources over time and locations is especially challenging during repetitive construction activities (Ungureanu et al. 2019). One shortcoming in current practice is that many different trades and subcontractors are involved in construction execution

(Dave et al. 2016) and there is a lack of coordination among the different trades (Dave et al. 2015). Therefore, appropriate resource allocation is an essential aspect within construction planning as resource flow is one of the most important flows within construction management (Koskela 1999).

Within the DES tool, it is possible to test different resource allocations on site and investigate the impacts on the PIs. The PDFs can be seen as productivity rates of the resources and if more resources are provided in the DES tool, works are executed faster. In general, a trade-off between the number of resources and the time to complete activities exists up to a turning point where additional resources hinder the execution (Ng et al. 2013). Additionally, the number of construction equipment has to match the number of workers, as executed works by equipment requires support by workers. Continuous workflows for all trades can be planned by the DES tool to prevent idle time.

4.3 Optimised Site Layout

The available space on construction sites is often limited and usually time pressure occurs during construction works. The coordination of different trades is complicated because of the dynamic interactions on sites, the complexity of activities, and the simultaneous construction executions. Time-space conflicts can occur, if at least two activities are executed on the same workspace during a certain time period (Akinci et al. 2002). These time-space conflicts are the major hindrance for executing works in a timely manner. A well-planned site layout improves construction productivity, reduces costs, and cares for the overall safety of workers during execution (RazaviAlavi and AbouRizk 2021).

The DES tool can be used to divide the construction site into different workspaces according to a LBS. For each workspace the needed information such as material quantity or constraints such as maximum possible activities on a workspace has to be stated. Thus, if planning with different workspaces, several trades can work simultaneously without conflicts on a construction site and execution can be accelerated. Thus, different site layouts and their impacts on the KPIs can be compared.

5 DISCRETE EVENT SIMULATION MECHANISMS

In alignment with the demonstration sites #4, #5, and #6 of the ASHVIN project (Łukaszewska et al. 2021b), work process patterns were determined and DEVS formalisms were created accordingly. Based on the patterns and the DEVS, stochastic DES mechanisms were modelled in R software for developing the DES tool. Within the DES tool, the defined PIs from section 3.5 are calculated automatically by the described equations. Table 4 presents a comparison of the developed PIs and the investigation of these on the chosen demonstration sites. During the construction works on demonstration site #5 in Gothenburg, no heavy construction equipment is used. Therefore, the utilisation rate for each trade was investigated instead of that for the equipment.

Table 4: Comparison demonstration sites and PIs

	#4 Rinteln	#5 Gothenburg	#6 Barcelona
Total duration	✓	✓	✓
Productivity rate	✓	✓	✓
Utilisation rate of equipment	✓	✓	✓
Number of concurrent trades	×	✓	×
Safety factor	✓	×	✓
Costs for equipment and resources	✓	✓	✓

5.1 #4 Rinteln: Mounting of Prefabricated Columns

5.1.1 #4 Industrial building in Rinteln, Germany

The demonstration site in Rinteln, Germany, is an industrial building with an area of almost 30,000 m² and a height of 12 meters (Figure 15). The building consists of two connected halls and is used for production. The building was mainly constructed of prefabricated components such as concrete columns or sandwich panels.



Figure 15: Visualisation industrial building in Rinteln, Germany (SN-online 2021)

5.1.2 Challenges and Rationale

The AEC sector strives to use prefabricated components and to standardise construction execution (Lu et al. 2018). It is estimated that the European market size for prefabricated buildings will rise from 24 \$ billion in 2020 to 32 \$ billion in 2026, yielding an increase of more than 30 % (Research and Markets 2021). Due to prefabrication, components are constructed in plants and delivered to construction sites, where they only have to be mounted. This procedure relocates the majority of works from construction site, where several uncertainties, such as changing weather conditions, can occur, to a controlled environment in plants. It is assumed, that the usage of prefabricated components can overcome several shortcomings in current construction practice. For instance, the prefabrication method reduces storage space on site, leads to less construction waste, and ensures safer working conditions for workers (Lu et al. 2018). However, construction by prefabrication requires a higher

demand for planning work. Thus, for this demonstration site, the work process pattern of *construction by prefabricated columns* was chosen. Timely delivery of prefabricated columns and coordinated delivery intervals are essential for successful construction execution. The prefabricated columns are delivered by trucks. Afterwards, the columns are mounted on their corresponding positions by construction workers and a mobile crane. It is aimed to enable a just in time (JIT) delivery to minimise storage space on construction site and achieve a continuous workflow for all resources.

5.1.3 Modelling of DES Mechanism

The DEVS formalism for the work process pattern *mounting of prefabricated columns* by a mobile crane is depicted in Figure 16.

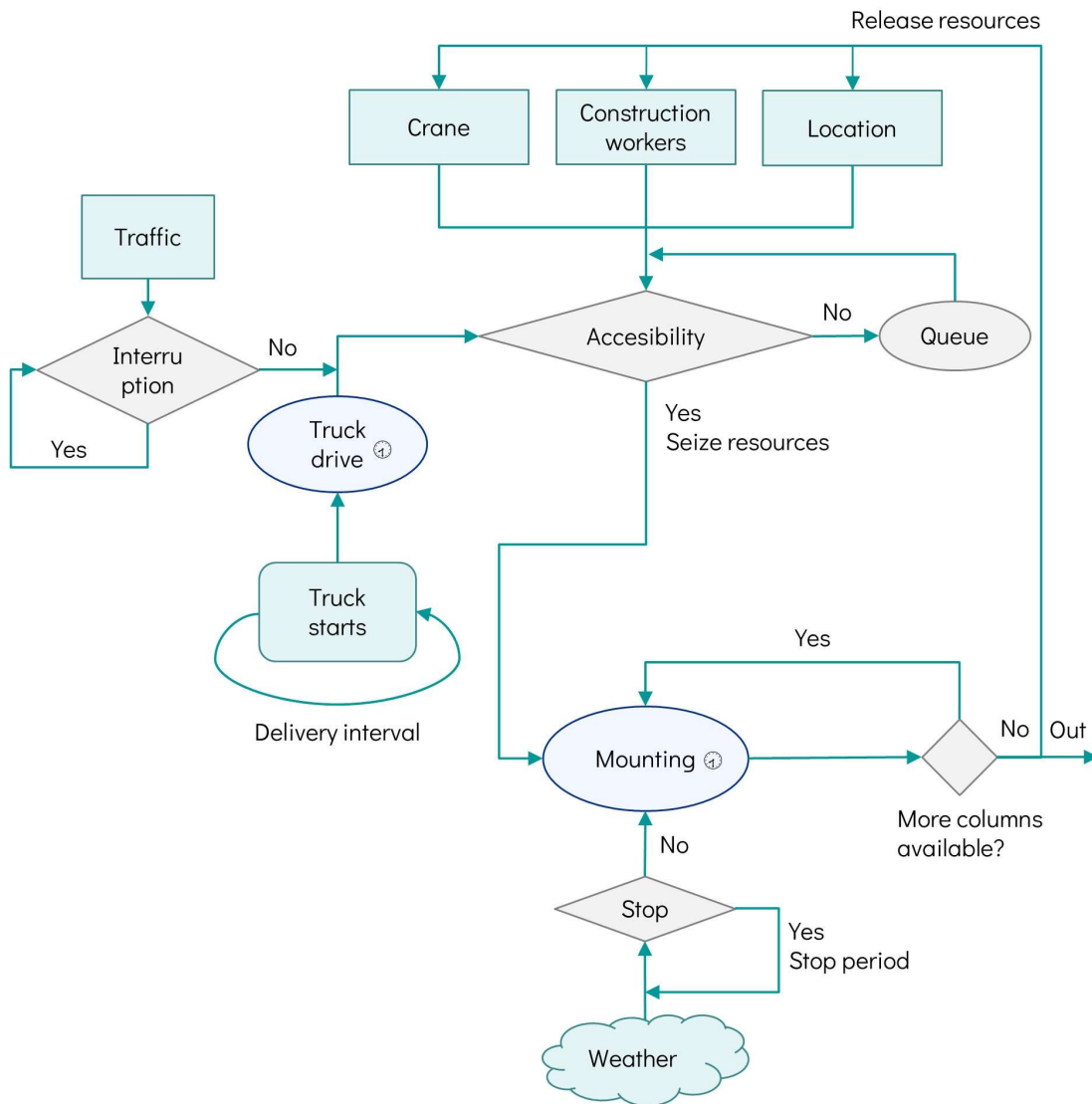

Figure 16: DEVS model for mounting prefabricated columns

The model simulation begins with a truck’s start for delivering columns according to determined departure times and delivery intervals. During the drive, the *delivery* duration is influenced by traffic. When the truck arrives at the construction site, the resources *mobile crane*, *construction workers*, and the *location* have to be available. If resources are already seized for another activity, the following *mounting* activity has to

wait in a queue. If the resources are available, they can be seized and the *mounting* activity can start. The *mounting* activity proceeds for the duration of the provided PDF and is repeated according to the number of columns on a truck. If all columns are mounted, the truck can leave and its position and the resources are released. The whole procedure is influenced by external weather conditions. For safety reasons, the *mounting* activity has to stop, if there is heavy wind.

$$MPC = \langle X, Y, D, M_{MPC} \mid d \in D, EIC, EOC, IC, select \rangle$$

$$X = \{ (in, v) \mid in \in IPorts, v \in \mathbb{R} \};$$

$$Y = \{ (out, v) \mid in \in OPorts, v \in \mathbb{R} \};$$

$$D = \{ Truck\ drive, Mounting \}$$

$$M_{MPC} = \{ M_{Truck\ drive}, M_{Mounting} \}$$

$$EIC \subseteq \{ ((Truck\ start, out), (Truck\ drive, in)); ((Traffic, out), (Truck\ drive, in)); ((Weather, out), (Mounting, in)) \}$$

$$EOC \subseteq \{ ((Mounting, out), (Self, out)) \}$$

$$IC \subseteq \{ ((Truck\ drive, out), (Mounting, in)) \}$$

$$select = \{ Truck\ drive, Mounting \}$$

Within the DES tool, several changes can be made in the settings to test different construction options (Table 5). The total number of columns, the columns per delivery, and the delivery interval have to be determined. Additionally, the number and costs of different resources can be changed. It is also possible to modify the PDFs for the activity durations in the DES tool. Weather forecasts can be included. A risky wind speed boundary and the maximum allowed wind speed are further setting options.

Table 5: Settings for mounting of prefabricated columns

Delivery	Setting	Resources	Setting	Weather	Setting
Total columns	Number	Construction worker	Number	Weather forecast	Table
Columns per delivery	Number	Mobile Crane	Number	Risky wind speed	Number
Delivery interval	PDF/ Number	Maximum cranes	Number	Maximum wind speed	Number
Activity	Setting	Costs per worker	Number		
Delivery	PDF	Costs per crane	Number		
Mounting	PDF				

5.1.4 Real-time data collection

During the entire construction execution, real-time data were gathered by a high-definition webcam. The camera was fixed next to the construction site and pointed at the site to have a broad overview of construction processes. Time-lapsed images were taken every ten minutes and uploaded via internet on the platform (Figure 17). It was consistently possible to access the images on the platform.



Figure 17: Time-lapsed images from Rinteln construction site (Goldbeck 2021)

5.1.5 Stochastic Productivity Modelling

The durations for the activity of mounting columns are based on the time-lapsed images. Therefore, the mounting durations result in ten-minute steps. Overall, two weeks were analysed. In the first week, 53 columns were mounted and in the second week 43 columns (Table 6).

Table 6: Durations for mounting columns

Activity	First week durations [minutes]	Second week durations [minutes]
Mounting	20, 10, 10, 10, 10, 10, 20, 20, 20, 20, 20, 10, 10, 10, 10, 10, 20, 30, 30, 10, 20, 20, 10, 20, 20, 20, 20, 20, 20, 10, 10, 10, 10, 20, 20, 10, 20, 10, 10, 10, 20, 10, 20, 20, 10, 20, 10, 20, 10, 20, 10, 20, 10, 20, 20, 10, 10, 10, 10	20, 20, 30, 20, 10, 10, 10, 10, 10, 10, 20, 20, 20, 30, 10, 10, 10, 10, 10, 20, 20, 10, 10, 10, 10, 10, 20, 20, 20, 10, 10, 10, 10, 20, 20, 20, 20, 10, 10, 10, 10, 20, 20, 10, 10, 10, 20, 20, 20, 10, 10, 10, 10, 20, 20, 10, 10, 10, 10

For the activity durations in Table 6, the in section 2.5.1 presented PDFs were optimised by MLE to determine respective parameters. The Goodness-of-Fit results for the whole dataset are presented in Table 7 for some of the investigated PDFs. As the different Goodness-of-Fit methods prefer different PDFs, the total ranking was calculated. It can be determined that the Weibull distribution has the lowest overall ranking and fits best according to the sample data.

The PDFs were determined for the activity durations based on the input data from the first week and based on both weeks. The resulting PDFs and their corresponding parameters are shown in Table 8.

Table 7: Comparison of possible PDFs for the mounting activity

Test statistic	PDF				
	Normal	LogNormal	Gamma	Logistic	Weibull
KS test	0.348	0.357	0.356	0.328	0.337
Cramér-von Mises test	2.294	2.511	2.446	2.241	2.171
Anderson-Darling test	13.276	14.617	14.284	12.894	12.458
AIC	613.066	593.013	597.464	620.531	606.899
BIC	618.195	598.142	602.593	625.660	612.028
Total ranking	3.8	3.8	3.6	3.4	2.4

Table 8: Resulting PDFs for the mounting activity

	First week	Two weeks
PDF	Weibull (2.973, 17.393)	Weibull (2.803, 16.904)

After finding suitable PDFs, the two-sided hypothesis tests were executed according to the number of observations and at a significance level of 0.05, as it is the most commonly used value for the significance level (Craparo 2007). For each of the three hypothesis tests, the p-values were computed according to the determined PDFs (Table 9). The p-values are below the significance level and the null hypothesis cannot be retained. The reason for this is the time-lapsed images, which were taken every ten minutes and provide vague durations. Thus, the input durations for determining the PDF have a discrete nature, but the PDFs assume continuous distributions.

Table 9: Comparison significance level and p-value for the mounting PDF

Test statistic	Result	p-value	Retain
KS test	0.337	$7.16 e^{-06}$	×
Cramér-von Mises test	2.171	$4.34 e^{-06}$	×
Anderson-Darling test	12.458	$6.25 e^{-06}$	×

However, as the aim of this approach is to use PDFs as activity durations to consider the variability during construction execution, the identified PDF of the whole data set was tested for the DES model calibration.

The data for the delivery duration of the trucks were collected by Google Maps. The location of the factory for the columns and the construction site were known. As no data could be collected by tracking the trucks, the delivery times from the factory to the construction site was checked several times between 7:00 a.m. and 3:00 p.m. on weekdays. The durations according to Google Maps are shown in Table 10. There is one outlier, as there was an accident on the motorway and the drive takes significantly longer.

Table 10: Truck delivery durations for columns

Activity	Durations [minutes]
Delivery	75, 75, 75, 75, 75, 76, 76, 76, 73, 78, 78, 75, 75, 75, 75, 75, 73, 78, 74, 75, 75, 79, 79, 75, 76, 77, 77, 90

For the delivery durations, PDFs were optimised by MLE. The Goodness-of-Fit results are presented in Table 11 for some of the investigated PDFs. The different Goodness-of-Fit techniques preferred different PDFs. Hence, the ranking for each PDF was calculated and the logistic distributions performs best (Table 12).

Table 11: Comparison of possible PDFs for the delivery duration of columns

Test statistic	PDFs				
	Normal	LogNormal	Logistic	Cauchy	Weibull
KS test	0.247	0.241	0.241	0.342	0.305
Cramér-von Mises test	0.530	0.489	0.304	0.674	0.912
Anderson-Darling test	3.020	2.776	1.781	4.014	4.873
AIC	145.992	142.697	132.240	119.360	167.684
BIC	148.657	145.362	134.905	122.025	170.348
Total ranking	4.4	2.4	1.4	3.6	6.2

Table 12: Resulting PDF for delivery of columns

Whole data set	
PDF	Logistic (75.772, 1.230)

Afterwards, the two-sided hypothesis test has to be executed to check whether the PDF can be retained at a significance level of 0.05. The calculated p-values for the three hypothesis tests are shown in Table 13. For all three tests, the p-value is above the significance level and, thus, the PDF for the delivery duration can be retained.

Table 13: Comparison significance level and p-value for the column's delivery PDF

Test statistic	Result	p-value	Retain
KS test	0.241	0.077	✓
Cramér-von Mises test	0.304	0.131	✓
Anderson-Darling test	1.781	0.122	✓

5.1.6 KPI Calculation

For the process pattern mounting of prefabricated columns, the productivity rate is calculated by dividing the number of mounted columns by the product of the number of resources and the total construction duration. The productivity rate can be calculated for the mobile cranes and the construction workers separately.

$$Productivity\ rate_{Crane} = \frac{Output}{Input} = \frac{Number\ mounted\ columns}{Total\ duration * n_{Crane}} \quad (7)$$

$$Productivity\ rate_{Worker} = \frac{Output}{Input} = \frac{Number\ mounted\ columns}{Total\ duration * n_{Worker}} \quad (8)$$

The utilisation rate for the mobile cranes is calculated by adding the active usage time of all *cranes* up divided by the total duration when they are requested, i.e. the sum of the active and idle time for all machines.

$$Utilisation\ rate_{Crane} = \frac{\sum_i^n (Active\ time\ crane_i)}{\sum_i^n (Active\ time\ crane_i + Idle\ time\ crane_i)} \quad (9)$$

The safety factor during the mounting of prefabricated columns considers risky weather conditions. The simulation stops construction operations, if a wind speed of 20 m/s is detected. If the wind speed is in the range of 10 to 19.99 m/s and construction works are executed, the duration is calculated as risk time.

$$Safety\ factor = \sum_i^n Active\ time\ crane_i\ during\ risky\ wind \quad (10)$$

if 10 m/s ≤ wind speed < 20 m/s

The costs for equipment and workers are calculated by multiplying the total duration in hours with the number of different resources and costs for each resource per hour. Resources were construction workers and cranes. Costs of 36.60 €/h (Eurostat 2021) were provided for the construction workers and 100 €/h for the crane according to a discussion with the site manager of the construction company. Supply costs were neglected in the calculation, but could be added if preferred.

$$Total\ costs = Total\ duration\ [h] * (n_{Worker} * Costs\ worker/h + n_{Crane} * Costs\ crane/h) \quad (11)$$

5.1.7 Calibration

For calibration, the DES was repeated 2,000 times for mounting 96 columns by one crane and the help of three construction workers. The determined Weibull PDF was used as the duration for the mounting activity. The delivery of the columns was excluded in the DES, as these values were not recorded during construction works. In Figure 18, the mean duration of the construction works in relation to the number of replications is displayed. The standard deviation is marked as light grey. It can be detected that 2,000 replications are sufficient as no significant variations occur after around 800 replications. In the following, six outliers were removed by the boxplot approach. This results in the durations in Table 14. The median and the mean have a similar duration to the real value of 1,440 minutes. The deviations of the minimum and maximum and the first quartile and third quartile are similar so that symmetrical results can be detected. There is a small shift to the higher values detectable. The standard deviation is around 55 minutes.

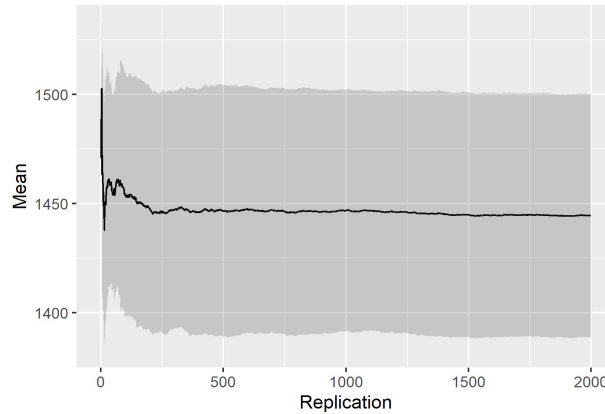

Figure 18: Resulting durations of the Monte-Carlo method #4 Rinteln

Table 14: Resulting durations #4 Rinteln

	Duration [minutes]
Minimum	1,290
First quartile	1,401
Median	1,442
Mean	1,443
Third quartile	1,483
Maximum	1,604
Standard deviation	55
Real duration	1,440

Afterwards, the two-sided hypothesis test was executed for the hypotheses:

$$H_0: \tilde{x}_1 = \tilde{x}_2$$

$$H_1: \tilde{x}_1 \neq \tilde{x}_2$$

with \tilde{x}_1 as the median of DES after 1,994 replications and \tilde{x}_2 as the real duration of the construction works with 1,440 minutes. 0.05 was chosen as the significance level. The resulting p-value for the Wilcoxon signed-rank test is 0.081. Thus, the null hypothesis cannot be rejected and the model is validated (Table 15).

Table 15: Wilcoxon-signed-rank test result #4 Rinteln, Germany

p-value	α	Retain
0.081	0.05	✓

5.1.8 DES Supported Lean Planning and Optimisation

The DES tool was applied for the planning of mounting 70 columns for the second hall as intended according to the master schedule. The delivery and mounting durations are based on the PDFs determined in section 5.1.5. Therefore, different delivery intervals and different resource allocations were tested as construction options within the DES tool. It has to be considered that the construction site is an open field. Hence, there are no space restrictions. As the construction works were planned for the

summer, there were no interruptions due to external weather conditions. The different settings for the construction options are presented in Table 16.

Table 16: Settings for construction options in the DES tool for #4 Rinteln

	Option 1	Option 2	Option 3	Option 4
Columns per delivery	2	4	4	8
Delivery interval	60	60	90	60
Number cranes	1	1	2	2
Number construction workers	3	3	6	6

For each possible option, the DES was repeated 1,000 times. The resulting PIs for each option are listed in Table 17. Option 4 leads to the lowest construction duration as more resources are provided in comparison to Option 1 and Option 2. Additionally, Option 4 results in low costs. Only for Option 2 a bit lower cost incurs. The reason is the high resource efficiency for the resources in both options. Hence, no idle time occurs as these two options achieve an efficiency of almost 100 %. According to the DES, Option 2 results in higher productivity as fewer resources were provided. Option 3 has the lowest productivity and resource efficiency results. In addition, this option leads to the highest costs. The reason is a suboptimal supply chain as much idle time occurs for the resources. It depends on the project manager which aspects are preferred. If a quick execution is required, a second crane must be used on site and more columns must be supplied per delivery as considered in Option 4. However, if there is no time pressure, Option 2 offers an even more efficient and a cheaper alternative. In general, it can be detected that the DES tool supports planning by optimising supply chain and resource allocations for the mounting of columns.

Table 17: Results for different options #4 Rinteln

PI	Option 1	Option 2	Option 3	Option 4
Duration [min]	2,146	1,155	1,632	626
Productivity _{Worker} [column/wh]	0.65	1.17	0.42	1.06
Productivity _{Crane} [column/wh]	1.94	3.5	1.25	3.18
Resource efficiency _{Crane} [%]	50,87	97.65	34.27	96.70
Total cost [€]	7,553	4,196	11,749	4,616
Safety	0	0	0	0

If the project managers decide on a construction option based on the DES tool, the results of the sequences are transferred as a JSON file to the ASHVIN platform. In combination with the CMT tool, the designed model can be compared to the built model. This simplifies comparison of as-designed with as-built status. The visualisation of the model on the ASHVIN platform is presented in Figure 19.

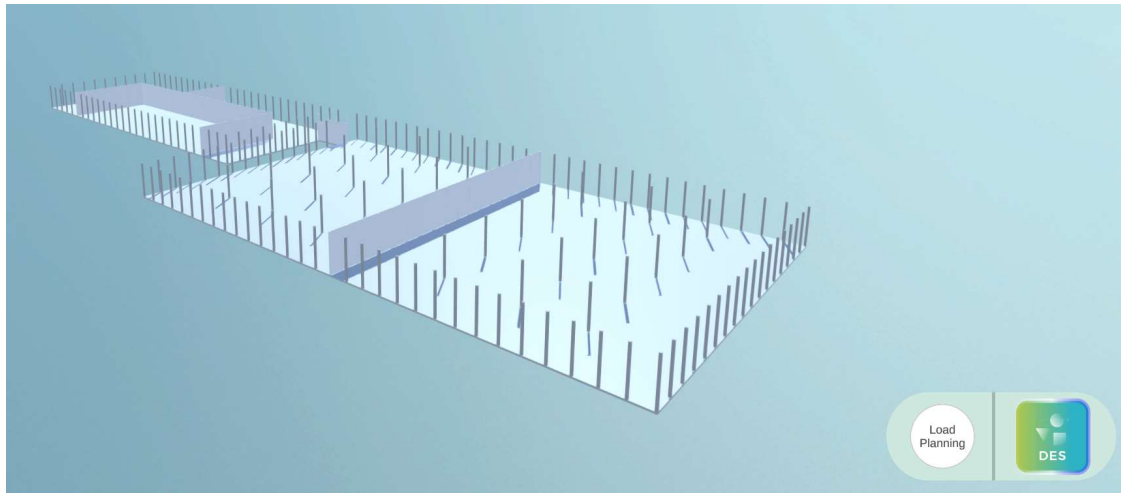

Figure 19: Visualisation on the ASHVIN platform #4 Rinteln

5.2 #5 Gothenburg: Finishing Works

5.2.1 #5 Kineum Office/Hotel building in Gothenburg, Sweden

The high-rise building Kineum is located in Gothenburg, Sweden, and has 27 floors with a height of 110 meters (Figure 20). It will be used as an office and hotel building. The whole building has a total floor area of around 30,000 m² and the area for each floor differs between 960 and 1,400 m².



Figure 20: #5 Kineum building in Gothenburg, Sweden

5.2.2 Challenges and Rationale

The Kineum building has the same or similar floor plans on many floors and for the finishing works the same activities have to be executed on each floor. During finishing works many different trades are working simultaneously on one floor. Therefore, coordination of the different trades is essential for successful execution to avoid time-space conflicts. Because of the repetitive nature of the finishing works and the large size of the floor area, the DT concept can be applied to achieve continuous improvement of ongoing works. A pull planning process according to Lean Construction principles can be applied to the different trades' workflows. Hence, for this demonstration site, the finishing works were chosen as a work process pattern.

5.2.3 Modelling of DES Mechanism

Figure 21 illustrates the DEVS formalism for the work process pattern *finishing works*. The DEVS is a coupled model consisting of nine atomic models for the nine different activities. For each activity, the respective workspace and the related trades have to be available to start. PDFs are provided as activity durations. If the workspace or the trade are occupied, the relevant activity has to wait in a queue until resources are released. Furthermore, the previous activity has to finish its work as otherwise the workspace would be still occupied. It has to be considered that the previous trade clears the workspace. The first activity is the *dry wall construction on one side* by dry wall constructors. Hereafter, *ventilation*, *plumbing*, and *electricity* are installed in the wall by HVAC, plumbing, and electrical trades. Afterwards, the dry wall constructor has to set the *second dry wall* and the *ceiling* followed by the *painting* activity executed by the painter trade. The *floor* activity is executed by floor layer trade and, finally, the *doors* are mounted by carpenters. In general, the whole procedure can be applied to different workspaces so that works are executed simultaneously.

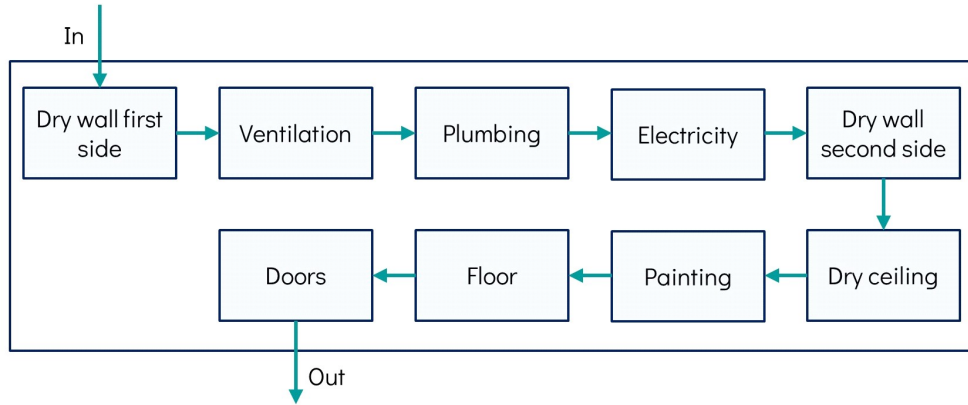

Figure 21: Coupled DEVS model for finishing works

$$CFW = \langle X, Y, D, M_{PPC} \mid d \in D, EIC, EOC, IC, select \rangle$$

$$X = \{ (in, v) \mid in \in IPorts, v \in \mathbb{R} \};$$

$$Y = \{ (out, v) \mid in \in OPorts, v \in \mathbb{R} \};$$

$$D = \{ \text{Dry wall first side, Ventilation, Plumbing, Electricity, Dry wall second side, Dry ceiling, Painting, Floor, Doors} \}$$

$$M_{MFW} = \{ M_{\text{Dry wall first side}}, M_{\text{Ventilation}}, M_{\text{Plumbing}}, M_{\text{Electricity}}, M_{\text{Dry wall second side}}, \\ M_{\text{Dry ceiling}}, M_{\text{Painting}}, M_{\text{Floor}}, M_{\text{Doors}} \}$$

$$EIC \subseteq \{ ((\text{Self}, in), (\text{Dry wall first side}, in)) \}$$

$$EOC \subseteq \{ ((\text{Doors}, out), (\text{Self}, out)) \}$$

$$IC \subseteq \{ ((\text{Dry wall first side}, out), (\text{Ventilation}, in)); ((\text{Ventilation}, out), (\text{Plumbing}, in)); \\ ((\text{Plumbing}, out), (\text{Electricity}, in)); ((\text{Electricity}, out), (\text{Dry wall second side}, in)); \\ ((\text{Dry wall second side}, out), (\text{Dry ceiling}, in)); ((\text{Dry ceiling}, out), (\text{Painting}, in)); \\ ((\text{Painting}, out), (\text{Floor}, in)); ((\text{Floor}, out), (\text{Doors}, in)) \}$$

$$select = \{ \text{Dry wall first side, Ventilation, Plumbing, Electricity, Dry wall second side, Dry ceiling, Painting, Floor, Doors} \}$$

For each of the nine atomic models, a DEVS submodel was created. The structure for all nine DEVS submodels is the same. The differences are the activities and the trades. As an example, the atomic model for the activity dry wall first side is presented (Figure 22).

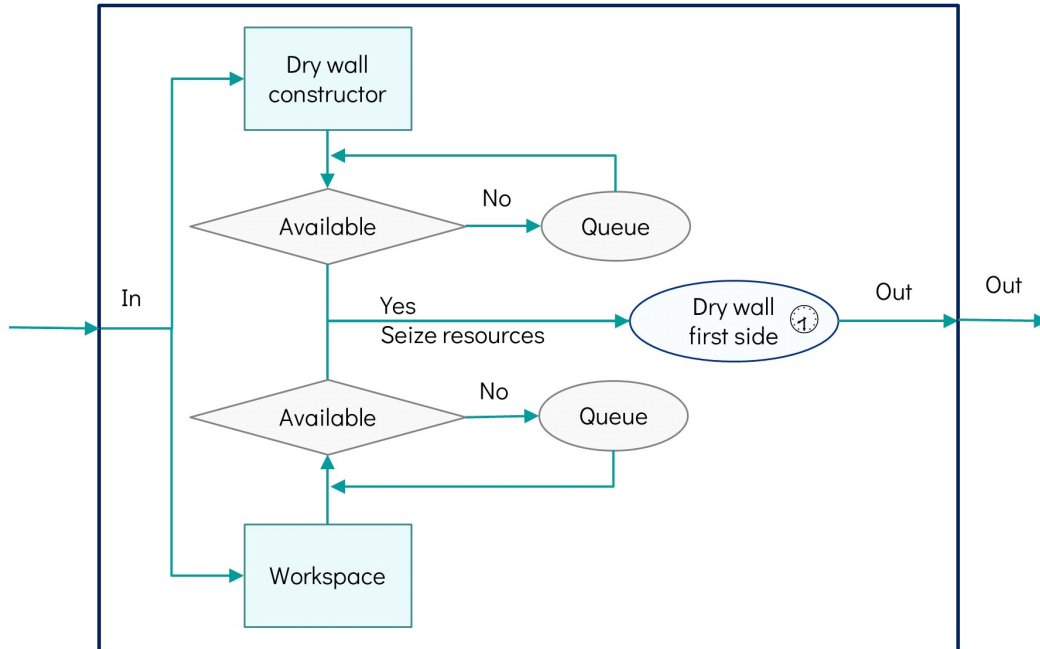

Figure 22: DEVS submodel for dry wall works

The different activities executed by different resources are listed in Table 18. Each of these activities is based on an atomic model such as in Figure 22.

Table 18: Activities and trades for finishing works

Activity	Trade
Dry wall first side	Dry wall constructor
Ventilation	HVAC
Plumbing	Plumbing
Electricity	Electrician
Dry wall second side	Dry wall constructor
Dry ceiling	Dry wall constructor
Painting	Painter
Floor	Floor layer
Door	Carpenter

Within the DES tool, several settings can be made for the finishing works (Table 19). For each trade, the number of resources and average cost per worker have to be stated. For the activity durations, PDFs can be modified. Additionally, the whole construction site can be divided into several workspaces. Material quantities for each workspace and the number of possible simultaneous works of a trade at a location must be input.

Table 19: Possible settings for finishing activities

Activity	Setting	Resource	Setting	Workspace	Setting
Dry wall first side	PDF	Dry wall constructor	Number	Number workspaces	Number
Ventilation	PDF	HVAC	Number	Maximum simultaneous works	Number
Plumbing	PDF	Plumbing	Number	Size dry walls [i]	Number
Electricity	PDF	Electrician	Number	Size ceiling [i]	Number
Dry wall second side	PDF	Painter	Number	Size painting [i]	Number
Dry ceiling	PDF	Floor layer	Number	Size floor [i]	Number
Painting	PDF	Carpenter	Number	Doors [i]	Number
Floor	PDF	Costs per worker	Number		
Door	PDF				

5.2.4 Real-time data collection

For this demonstration site, no data could be collected. If real-time data can be collected in the future, it will be possible to incorporate them into data-driven PDFs. For such a work process pattern, the recording of images at a certain interval would be expedient. Thus, the processes of different trades can be tracked and possible time-space conflicts among trades can be detected.

5.2.5 Stochastic Productivity Modelling

The productivity rates are based on the schedule provided by the construction company. Within the schedule, the planned working hours for each activity are provided. The material quantities were derived from the 3D Building information modelling (BIM) file. For the dry wall works and the three wall installations, the wall size was selected from the BIM file as a reference value. For the ceiling works the area for dry construction was calculated. This excludes staircases or storage rooms. The painting area includes the dry walls and solid walls. For the floor layer activity, the floor size was derived. Additionally, the number of doors was determined. For each activity, a normal distribution with no deviation is assumed. The mean duration is calculated by dividing the material quantities by the total activity duration in hours. The provided durations, the material quantities, and the resulting PDFs are indicated in Table 20.

Table 20: Resulting PDFs for the finishing work activities

Operation	Working duration [hours]	Material	PDF
Dry wall first side	498	2,486 m ²	Normal (0.200, 0)
Ventilation	368	2,486 m ²	Normal (0.148, 0)
Plumbing	70	2,486 m ²	Normal (0.028, 0)
Electricity	70	2,486 m ²	Normal (0.028, 0)

Operation	Working duration [hours]	Material	PDF
Dry wall second side	410	2,486 m ²	Normal (0.165, 0)
Dry ceiling	160	963 m ²	Normal (0.166, 0)
Painting	220	5,272 m ²	Normal (0.042, 0)
Floor	395	1,120 m ²	Normal (0.353, 0)
Doors	120	72 pieces	Normal (1.667, 0)
Total	2,311		

5.2.6 KPI Calculation

For the demonstration site in Gothenburg, the productivity rates for each trade are calculated during the execution of the finishing works. The productivity rate is calculated for each trade by dividing the material quantity by the total duration each trade is demanded on site multiplied by the number of resources.

$$\begin{aligned}
 \text{Productivity rate trade}_i &= \frac{\text{Output}}{\text{Input}} \\
 &= \frac{\text{Material quantity}_i}{\sum_i^n (\text{Active time trade}_i + \text{Idle time trade}_i) * n_i}
 \end{aligned} \quad (12)$$

As no heavy construction equipment is used for these activities, the resource efficiency is calculated for each trade by dividing the active time through the whole time the trade is demanded on site.

$$\text{Resource efficiency trade}_i = \frac{\sum_i^n (\text{Active time trade}_i)}{\sum_i^n (\text{Active time trade}_i + \text{Idle time trade}_i)} \quad (13)$$

Furthermore, the time is calculated when two or more trades work at the same workspace by:

$$\begin{aligned}
 \text{Duration concurrent trades} &= \sum \text{Duration} \\
 &, \text{if number of trades at a workspace} \geq 2.
 \end{aligned} \quad (14)$$

The total costs are calculated by multiplying the active and idle duration for each trade with the number of resources per trade. For each worker, general costs of 37.30 €/h were provided (Eurostat 2021), yielding daily costs of 298.40 €/day.

$$\begin{aligned}
 \text{Total costs} &= \sum_i^n ((\text{Active time trade}_i + \text{Idle time trade}_i) * n \text{ trade}_i) \\
 &* \text{Costs worker/day}
 \end{aligned} \quad (15)$$

5.2.7 Calibration

For this demonstration site, the Monte-Carlo method and the Wilcoxon-signed-rank test were not executed, as the DES is not based on collected real-time data. The activity durations were derived from the provided schedule and only normal distributions with no deviations were assumed. The resulting total duration of the DES is 2,311 hours. This is the same value as the planned duration in the schedule. Hence, the DES model can be seen as calibrated.

5.2.8 DES Supported Lean Planning and Optimisation

The DES tool was used for the planning of the finishing works on the 16th floor of the KINEUM building. The DES was simulated in whole days instead of hours as a daily planning process is more reasonable for the determined planning horizon. The hours are divided by eight working hours and rounded up. Hence, there are even small buffers, for the case a trade progresses slowly. Three different options with different resource allocations and several workspaces are compared (Table 21). The activity durations are based on section 5.2.5.

Table 21: Settings for construction options in the DES tool for #5 Gothenburg

	Option 1	Option 2	Option 3
Workspaces	1	3	3
Number dry constructor	4	4	10
Number HVAC	4	4	8
Number plumbing	2	2	1
Number electrician	2	2	1
Number painter	4	4	2
Number floor layer	4	4	5
Number carpenter	2	2	4

The results of the DES are presented in Table 22. For Option 1, all trades have a continuous workflow besides the dry constructors, as there is only one workspace. After the dry constructors install the first dry wall side, they have to wait for the inner wall installations until they can continue with the second side and the ceiling. Thus, only the dry constructors spend around 33 % of the time waiting and are not used efficiently. For all options, the occurrence of different trades on one workspace was prevented in the DES.

Table 22: Results for different options #5 Gotheburg

PI	Option 1	Option 2	Option 3
Duration [days]	155	87	59
Productivity _{Dry constructor} [m ² /wh]	1.84	2.58	2.01
Productivity _{HVAC} [m ² / wh]	3.38	2.88	2.99
Productivity _{Plumbing} [m ² / wh]	31.08	8.18	28.25
Productivity _{Electrician} [m ² / wh]	31.08	8.18	31.08
Productivity _{Painter} [m ² / wh]	1.77	6.34	19.38
Productivity _{Floor layer} [m ² / wh]	1.4	1.13	1.17
Productivity _{Carpenter} [pieces/wh]	0.3	0.17	0.225
Resource efficiency _{Dry constructor} [%]	67	100	86
Resource efficiency _{HVAC} [%]	100	93	100
Resource efficiency _{plumbing} [%]	100	32	91

PI	Option 1	Option 2	Option 3
Resource efficiency <i>Electrician</i> [%]	100	32	100
Resource efficiency <i>Painter</i> [%]	100	35	94
Resource efficiency <i>Floor layer</i> [%]	100	77	80
Resource efficiency <i>Carpenter</i> [%]	100	59	80
Number of concurrent trades [days]	0	0	0
Total costs [€]	209,477	224,994	205,598

For Option 2, the whole floor was divided into three workspaces of similar sizes. The resource allocation was not changed. Within the second Option, the total construction duration can be decreased significantly as construction works can be executed simultaneously on several workspaces. The trade dry constructor is used much more efficiently compared to Option 1. However, for the remaining trades, more idle time occurs according to the DES. Hence, in Option 3, three workspaces are kept and the resource allocations were changed. The third Option leads to the fastest construction execution and is still the cheapest option due to the overall efficient use of the different workers. All trades have an efficiency of more than 80 %. For some trades higher efficiencies can be achieved in Option 1. But it has to be considered that this is a forward planning and deviations from this schedule will occur. Therefore, small buffers in the schedule can be seen as useful to avoid conflicts among different trades. As can be detected in Figure 23, for the first workspace, no idle time occurs within Option 3. Only for the second and the third workspace brief idle times can occur according to the DES of Option 3. However, if the planning is adjusted on a weekly basis according to the Last Planner® System, the works can be adapted more flexible to avoid these short idle times. Overall, it can be stated that continuous workflows can be achieved and the site is used more efficiently by the application of the DES tool.

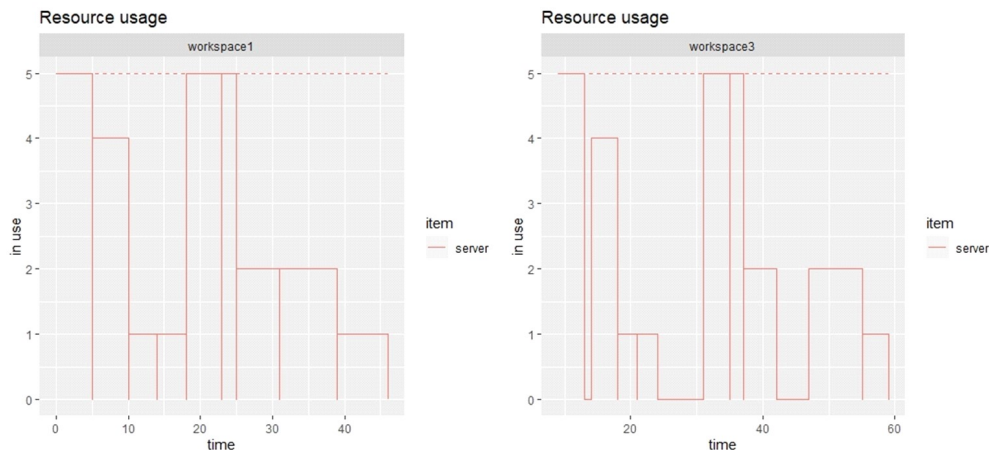

Figure 23: #5 Gothenburg – Option 3 - Workspace 1 and Workspace 3 usage

The results of the chosen option are provided as JSON files to the CMT tool. Hence, the sequence of construction works can be visualised for improved understanding and communication among the trades. Each activity a certain colour is assigned and the different workspaces are marked in the appropriate colours the duration a trade stays at the location according to the DES tool (Figure 24). Thus, the flow of the different

trades over the various workspaces can be displayed over time. If there would be a potential conflict among trades for a workspace, this would be easily detectable. The users of the tool can use a time scroll bar for navigation to analyse the planned construction execution.

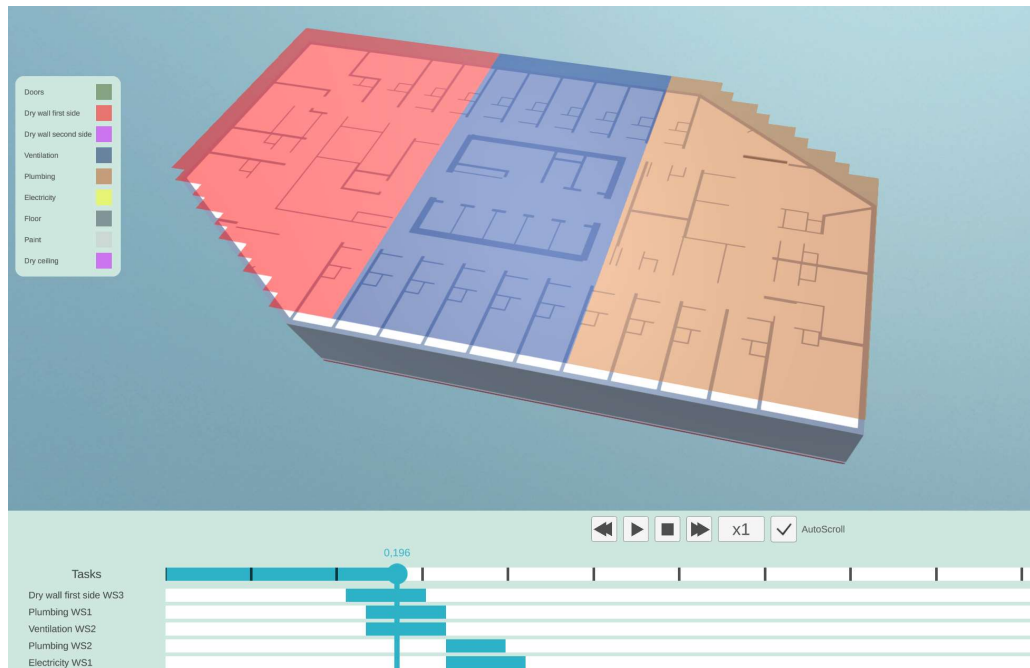

Figure 24: Visualisation of the DES results on the ASHVIN platform #5 Gothenburg

5.3 #6 Barcelona: Concrete Works by Crane

5.3.1 #6 Office building in Barcelona, Spain

Demonstration site #6 is the construction of an office building located in the urban area of Barcelona (Figure 25). The shell construction consists of reinforced concrete with long-spanned slabs. The building is shaped like a U and has seven floors with an area of around 16,524 m². Due to execution of the works within a dense urban area, the construction site has limited space for equipment and vehicles to deliver material.



Figure 25: Visualisation #6 Office building in Barcelona, Spain

5.3.2 Challenges and Rationale

As densification of cities is a current topic, the efficient usage of limited construction space in urban areas is needed. Construction works require the usage of heavy equipment such as cranes. Cranes take a crucial part on construction sites by moving materials and effect project costs and duration significantly (Peng et al. 2018). Due to limited space, the risk of hazardous situations rises as several activities occur simultaneously next to each other with no distance between them. Additionally, there is not much space on the streets as usual traffic takes place and should be interrupted as little as possible. It was detected that the duration between leaving the concrete mixing plant and start of the curing process should not surpass a duration of 1.5 hours, as the quality of concrete decreases afterwards significantly (Lin et al. 2010). Thus, the coordination of material deliveries should be on time to minimise disturbances.

Based on these aspects, for this demonstration site, the work process pattern of *concrete works executed by a tower crane* was chosen. Ready mixed concrete was delivered in certain intervals to the construction site by trucks. Subsequently, the concrete was poured into formwork by a tower crane. This was a repetitive process until the concrete mixer truck was empty. Subsequently, when the empty concrete mixer truck left, the next truck could arrive to start the repetitive process again.

5.3.3 Modelling of DES Mechanism

For the work process pattern of concrete pouring by a tower crane, the coupled DEVS framework is displayed in Figure 26. The concrete works executed by crane are considered as a separate DEVS submodel (Figure 27). The model begins the simulation with the *delivery* of concrete by a truck. During the delivery, *traffic* can affect the delivery duration, which can be provided by a PDF. A certain delivery interval can be stated. If the truck arrives at the construction site, a parking position on the street has to be available. Afterwards, the *concrete pouring* process can start. Thus, the resources crane, crane operator, and construction workers must be available and the pouring location has to be free. If these resources are seized or the location is occupied, the simulation cannot proceed and the activity has to wait in a queue. If the resources are available, the concrete process can be started. This repetitive process consists of four operations – *filling*, *lifting up*, *pouring*, and *lifting down* – which will be repeated until the concrete truck is empty. Afterwards, the truck can leave. If the next truck arrives, the concrete process begins again. The whole process is influenced by weather conditions. The coupled concrete works formalism is defined as:

$$CCW = \langle X, Y, D, M_{PPC} \mid d \in D, EIC, EOC, IC, select \rangle$$

$$X = \{ (in, v) \mid in \in IPorts, v \in \mathbb{R} \};$$

$$Y = \{ (out, v) \mid in \in OPorts, v \in \mathbb{R} \};$$

$$D = \{ Truck\ drive, CW \}$$

$$M_{PPC} = \{ M_{Truck\ drive}, M_{CW}, M_{Truk\ leaves} \}$$

$$EIC \subseteq \{ ((Truck\ start, out), (Truck\ drive, in)); ((Traffic, out), (Truck\ drive, in)) \}$$

$$EOC \subseteq \{ ((CW, out), (Self, out)) \}$$

$$IC \subseteq \{ ((Truck\ drive, out), (CW, in)) \}$$

$select = \{Truck\ drive, CW\}$

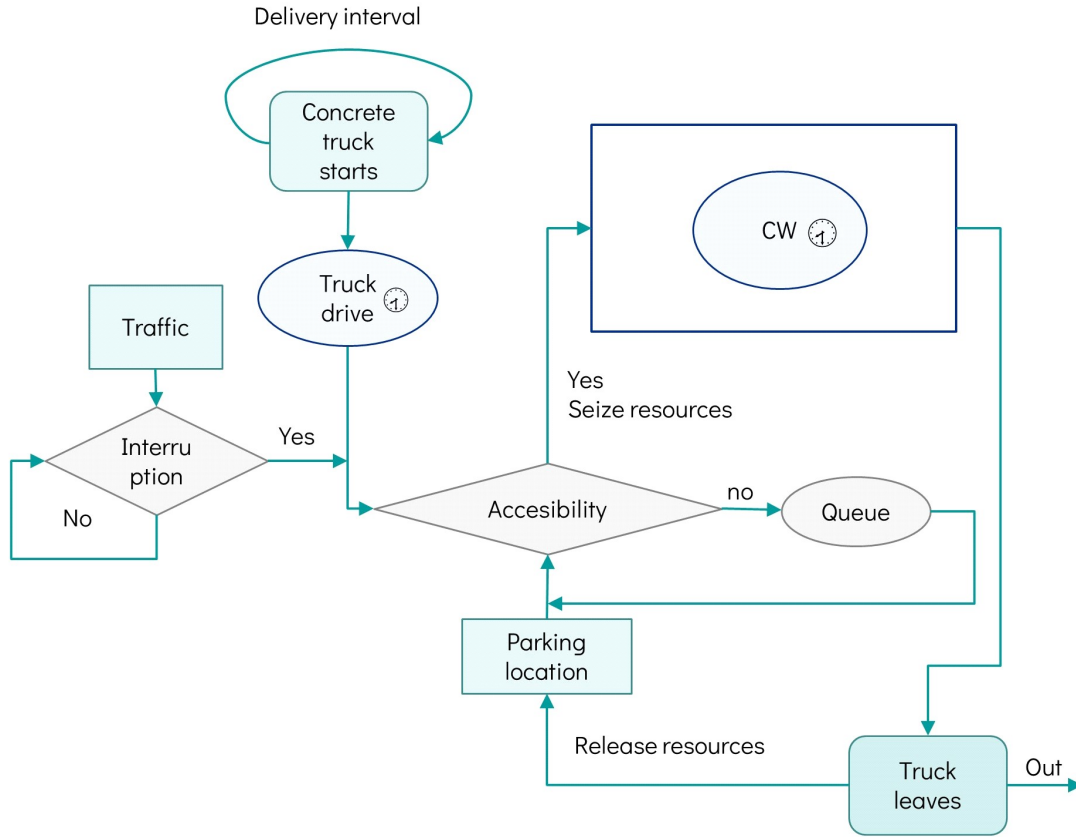

Figure 26: Coupled DEVS model for concrete works by a crane

The DEVS formalism for the submodel of concrete works is described as:

$$CW = \langle X, Y, D, M_{CW} \mid d \in D, EIC, EOC, IC, select \rangle$$

$$X = \{ (in, v) \mid in \in IPorts, v \in \mathbb{R} \};$$

$$Y = \{ (out, v) \mid in \in OPorts, v \in \mathbb{R} \};$$

$$D = \{ Filling, Lifting\ up, Pouring\ concrete, Lifting\ down \}$$

$$M_{CW} = \{ M_{Filling}, M_{Lifting\ up}, M_{Pouring\ concrete}, M_{Lifting\ down} \}$$

$$EIC \subseteq \{ ((Truck\ out), (Filling, in)); ((Weather, out), (Filling, in)) \}$$

$$EOC \subseteq \{ ((Pouring\ concrete, out), (Self, out)) \}$$

$$IC \subseteq \{ ((Filling, out), (Lifting\ up, in)); ((Lifting\ up, out), (Pouring\ concrete, in)); ((Pouring\ concrete, out), (Lifting\ down, in)); ((Lifting\ down, out), (Filling, in)) \}$$

$$select = \{ Filling, Lifting\ up, Pouring\ concrete, Lifting\ down \}$$

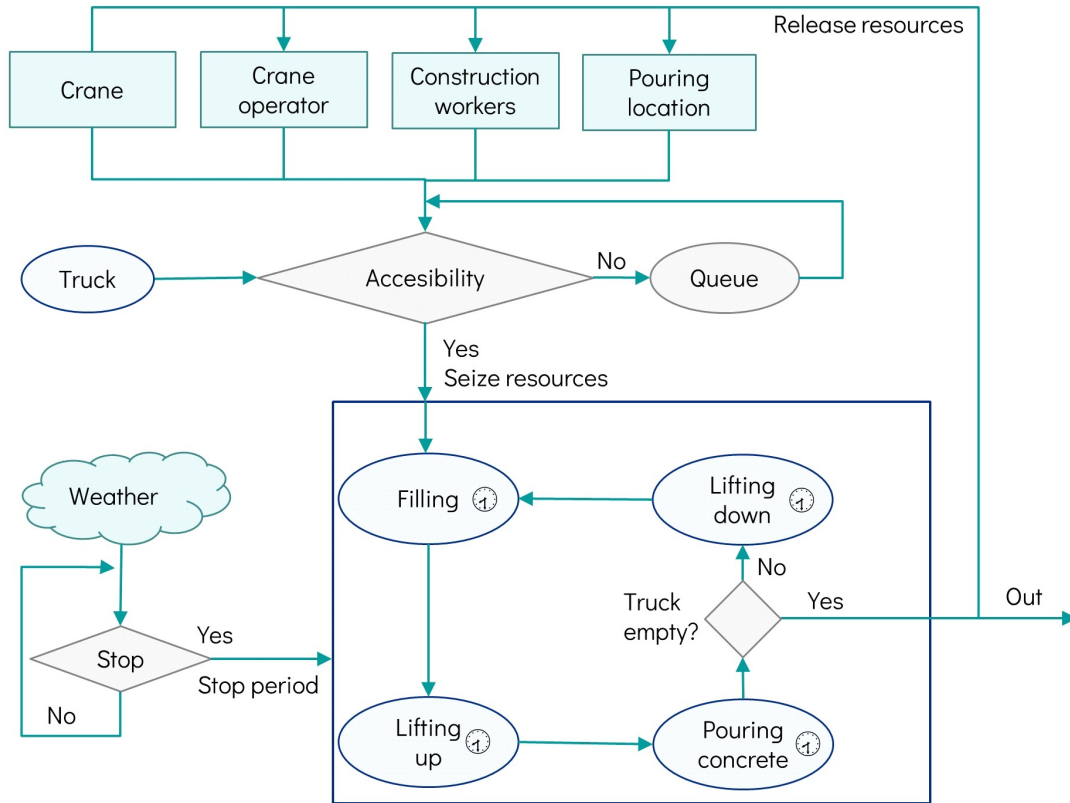

Figure 27: DEVS submodel for concrete works

The number and costs of resources can be changed in the tool, i.e. construction workers, cranes, crane operators, workspaces, and the parking locations for trucks. The PDFs for each activity have to be stated as well. Additional inputs are the total concrete volume, the capacity of the truck, the capacity of the concrete bucket, and the delivery interval. Furthermore, a weather forecast, a risky wind speed boundary, and the maximum allowed wind speed can be entered into the tool (Table 23).

Table 23: Settings for concrete pouring by crane activity

Delivery	Setting
Total volume concrete [litres]	Number
Capacity truck [litres]	Number
Capacity bucket [litres]	Number
Delivery interval	PDF / Number
Operation duration	Setting
Delivery	PDF
Filling	PDF
Lifting up	PDF
Pouring	PDF
Lifting down	PDF

Resources	Setting
Construction workers	Number
Cranes	Number
Crane operators	Number
Concrete location	Number
Truck location	Number
Costs per worker	Number
Costs per crane	Number
Weather	Setting
Weather forecast	Table
Risky wind speed	Number
Maximum wind speed	Number

5.3.4 Real-time data collection

At this demonstration site, movement crane data were collected by sensors. Different sensors were mounted on a crane hook during the concrete pouring process (Figure 28). The mounted WTGAHRS2 sensor is a combination of an inertial measurement unit (IMU), a GPS tracker, and a barometer. Thus, three-axis acceleration and velocity by the IMU, longitude/latitude/altitude by the GPS tracker, and height by the barometer could be collected. The combined sensors were connected to an ESP32 microcontroller to send the collected data via internet to the ASHVIN platform or to save it on a memory card. Additionally, the IMU sensor WT901, which has integrated Wi-Fi, was mounted.



Figure 28: Sensor mounting on the crane hook #6 Barcelona

5.3.5 Stochastic Productivity Modelling

Collected movement data of crane operations were analysed by data mining to extract the durations of each repetition of each operation (Table 24). The data fusion and mining process is described in D3.3. For the first truck, each operation was repeated nine times and for the second truck, each operation was repeated eight times, except lifting down, which was repeated only seven times as the concrete process was finished and the bucket was not lifted down again.

Table 24: Concrete pouring activity durations

Operation	First truck	Second truck
Filling [seconds]	36, 103, 77, 73, 81, 92, 91, 73, 90	131, 65, 58, 72, 62, 68, 84, 49
Lifting up [seconds]	124, 82, 114, 99, 111, 104, 119, 93, 43	99, 93, 85, 95, 98, 123, 79, 90
Concrete pouring [seconds]	37, 112, 58, 59, 57, 68, 83, 50, 240	89, 33, 30, 65, 42, 26, 337, 72
Lifting down [seconds]	90, 108, 91, 96, 76, 98, 101, 70, 108	84, 76, 99, 110, 99, 101, 105

According to the different operation durations, for each of the possible PDFs the respective optimal distribution parameters were determined by MLE. The resulting PDFs according to determined parameters are used for Goodness-of-Fit statistics to determine the most suitable PDF. As an example, the comparison of possible PDFs

for the operation *Filling* is displayed in Table 25 based on the whole data set of both trucks. It can be clearly detected that the Logistic distribution fits best according to the provided data.

Table 25: Comparison of possible PDFs for Filling operation based on full data set

Test statistic	PDFs				
	Normal	LogNormal	Logistic	Cauchy	Weibull
KS test	0.118	0.112	0.092	0.097	0.137
Cramér-von Mises test	0.031	0.037	0.017	0.028	0.048
Anderson-Darling test	0.241	0.265	0.145	0.240	0.337
AIC	155.942	155.947	155.232	158.810	156.642
BIC	157.609	157.614	156.899	160.477	158.308

Afterwards, for each operation suitable PDFs were identified according to the data-based durations. It was distinguished between the durations of the first concrete delivery and the whole data set. The resulting PDFs and their parameters are presented in Table 26.

Table 26: Resulting PDFs for concrete pouring operations

Operation	First concrete truck	Two concrete trucks
Filling	Logistic (81.87, 9.33)	Logistic (75.89, 11.45)
Lifting up	Logistic (102.30, 12.19)	Weibull (6.37, 104.39)
Concrete pouring	Log normal (4.28, 0.51)	Log normal (4.19, 0.66)
Lifting down	Weibull (9.58, 98,32)	Weibull (10.26, 99.53)

After finding suitable PDFs, the two-sided hypothesis tests were executed by the p-value approach according to the number of observations and for a significance level of 0.05. Therefore, for each of the three hypothesis tests, the p-values were computed according to the determined PDFs. Again, an example is presented for the operation *Filling* based on the whole data set (Table 27). The results of the respective computed p-values are above the significance level of 0.05 and the null hypothesis cannot be rejected.

Table 27: Comparison significance level and p-value for the Filling PDF based on the whole data set

Test statistic	Result	p-value	Retain
KS test	0.092	0.999	✓
Cramér-von Mises test	0.017	0.999	✓
Anderson-Darling test	0.145	0.999	✓

The hypothesis tests by the p-value approach were executed for each of the determined PDFs from Table 26. Thus, it was possible to determine that for all PDFs

the null hypothesis can be retained and the final PDFs can be used as input parameters for activity durations within the DES tool.

5.3.6 KPI Calculation

The productivity rate is calculated by multiplying the number of resources with the total duration as input and the quantity of poured concrete as output. On the one hand, the productivity of cranes is calculated. On the other hand, the productivity of construction workers is investigated.

$$Productivity\ rate_{Crane} = \frac{Output}{Input} = \frac{Quantity\ poured\ concrete}{Total\ duration * n_{Crane}} \quad (16)$$

$$Productivity\ rate_{Worker} = \frac{Output}{Input} = \frac{Quantity\ poured\ concrete}{Total\ duration * n_{Worker}} \quad (17)$$

The utilisation rate of equipment is calculated by the summed usage time of cranes divided by the total duration of planned construction works multiplied by the number of cranes.

$$Utilisation\ rate = \frac{\sum_i^n (Active\ time\ crane_i)}{Total\ duration * n_{Crane}} \quad (18)$$

The safety factor considers wind conditions during crane operations. Hazardous situations can occur, if there is wind during crane operations. Thus, the risk duration is calculated when wind is in the range between 10 to 19.99 m/s according to input weather forecasts and construction works are executed at this time.

$$Safety\ factor = Duration\ risky\ wind\ speed * Activity\ time\ crane\ during\ risky\ wind \\ if\ 10\ m/s \leq wind\ speed < 20\ m/s$$

The personnel costs for equipment and workers were calculated by multiplying the total duration in hours with the number of different resources and costs for each resource per hour. Resources were construction workers, cranes, and crane operators. According to Eurostat (2021) the average cost per construction worker per hour for a construction company in Spain are 22.80 €. The assumed cost for a crane per hour was 85 €. Establishment costs were not considered as these expenses would occur independently of the operation duration.

$$Total\ costs = Total\ duration\ [h] * (n_{Worker} * Costs\ worker/h + n_{Crane} * Costs\ crane/h) \quad (19)$$

5.3.7 Calibration

For calibration, the observed construction process was modelled in a stochastic DES. The PDFs based on the whole data set were used as input parameters in the DES model. The DES simulation was repeated 5,000 times in a Monte-Carlo method. The results for the mean durations according to the number of repetitions can be seen in Figure 29. After 1,000 repetitions, there is no big deviation from the mean. Thus, the results can be seen as meaningful. The real duration of construction works was measured on site and is equal to 5,932 seconds or 98:52 minutes. The standard deviation is marked as the light grey area around the mean.

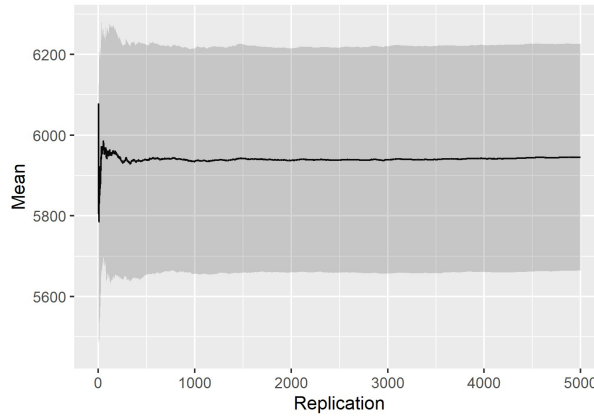

Figure 29: Resulting durations of the Monte-Carlo method #6 Barcelona

Due to the outlier detection by the boxplot approach, 61 durations were removed. Hence, the data set contained 4,939 durations, resulting in the durations shown in Table 28. The mean and the median are very close to the real duration, differing only by a few seconds. The standard deviation is around 277 seconds.

Table 28: Resulting durations #6 Barcelona

Duration [s]	
Min	5,198
First quartile	5,750
Median	5,926
Mean	5,939
Third quartile	6,113
Max	6,670
Standard deviation	277
Real	5,932

Afterwards, the two-sided hypothesis test was executed for the hypotheses:

$$H_0: \tilde{x}_1 = \tilde{x}_2$$

$$H_1: \tilde{x}_1 \neq \tilde{x}_2$$

with \tilde{x}_1 as DES model's median of 5,926 seconds and \tilde{x}_2 as the real duration of 5,932 seconds. For testing the hypothesis, the Wilcoxon-signed-rank test was executed at a significance level of 0.05. The resulting p-value is 0.741, which is above the advanced determined significance level (Table 29). Thus, the null hypothesis cannot be rejected and the model is validated.

Table 29: Wilcoxon-signed-rank test result #6 Barcelona

p-value	α	Retain
0.741	0.05	✓

5.3.8 DES Supported Lean Planning and Optimisation

During data collection, three walls have been concreted. Walls of the same size had to be concreted afterwards on the opposite side. Therefore, two deliveries of fresh concrete by trucks were needed. The DES tool can support the planning process for determining the punctual delivery of concrete by trucks to avoid idle time. The three walls have a total volume of 15.479 m³ according to the Revit file. 17 buckets of concrete have to be poured into the formwork. As no data regarding the delivery duration were collected, only an arrival time was assumed within the usage of the DES tool. The actual simulation starts, when the first truck arrives, as the resources can execute other works in advance. After starting the pouring process, the resources are seized until the whole pouring process is finished. Regarding the weather conditions, no disruptions are considered as in reality. The different options were simulated with 2,000 replications and their impacts regarding the PIs were compared. Because of space restrictions, the minimum number of resources was assumed within the DES, i.e. one crane, one crane operator, and four construction workers. Two construction workers fill the concrete from the truck into the bucket and two construction workers pour the concrete into the formwork and vibrate it. Due to the limited construction space, an increase of the resources is not possible. Hence, the difference between the options is the delivery interval. In reality, the second truck arrived 115 minutes after the first, which led to an idle time of around one hour for the workers and the crane. Three different options with a delivery interval of 60, 30, and 50 minutes were compared to the real execution (Table 30).

Table 30: Settings for construction options in the DES tool for #6 Barcelona

	Observed	Option 2	Option 3	Option 4
Delivery interval [minutes]	115	60	30	50
Number cranes	1	1	1	1
Number crane operators	1	1	1	1
Number construction workers	4	4	4	4

The resulting PIs for the different options are presented in Table 31. The observed option is based on the execution during data collection.

Table 31: Results for different options #6 Barcelona

PI	Observed	Option 1	Option 2	Option 3
Duration [seconds]	9,676	6,377	5,918	5,937
Productivity _{Worker} [m ³ /wh]	1.03	1.55	1.55	1.55
Productivity _{Crane} [m ³ /wh]	5.16	7.74	7.74	7.74
Resource efficiency crane [%]	61.03	92.58	100	100
Total cost [€]	597	398	398	398
Safety	0	0	0	0

Option 1 leads to significant improvements in comparison to the actual execution as the second truck arrives already after 60 minutes and the idle time for the crane and construction workers can be reduced. Thus, all PIs are influenced positively. However, idle time still occurs for the resources. Exemplary resource usage of construction workers for all 2,000 replications is presented in Figure 30. After the first truck is empty, a short idle time occurs at around 3,000 seconds. The usage of the crane would look the same as the resources are used in combination.

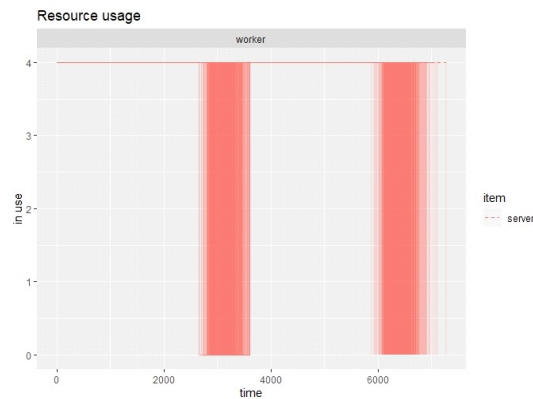

Figure 30: #6 Barcelona – Option 1– Worker usage

The second Option, a delivery interval of 30 minutes, improves the resource efficiency of the crane and construction workers as they are used 100 % of the time. Hence, it can be stated that no idle time for the resources occurs and continuous workflows can be enabled (Figure 31). However, the trucks accumulate on the streets and congestion arises for 20 to 30 minutes as the second truck arrives early.

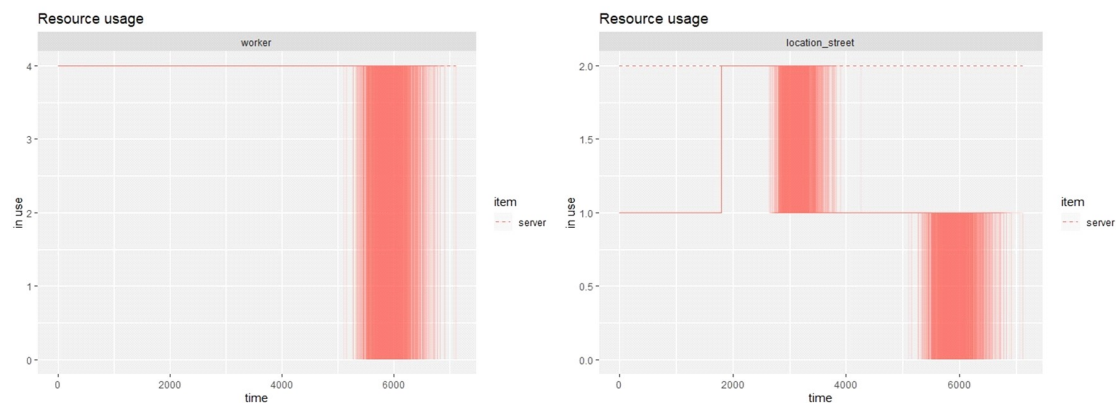

Figure 31: #6 Barcelona – Option 2 – Construction worker and street location usage

Option 3, a delivery interval of 50 minutes, has the same resulting PIs as Option 2, besides a few seconds longer construction duration. However, the truck deliveries are better coordinated and only in some replications a brief overlap of the two trucks occur on the streets (Figure 32). Nevertheless, the resources have continuous workflows. In some replications, there is a brief idle time, which does not influence the PIs negatively. Based on the DES tool, a delivery interval of around 50 minutes would optimise the construction execution. All stated PIs would be influenced positively and continuous workflows can be enabled. Nonetheless, congestion on the street can be avoided. The supply chain and the site layout can be improved significantly by applying the DES tool.

Within this example only the arrival of two trucks was simulated, but if considering a higher demand of concrete for construction, the positive effects will increase. As the exact arrival time is influenced by several factors such as traffic during the delivery and cannot be determined on point, the guideline to arrive 50 minutes after the arrival of the previous truck is a reasonable decision.

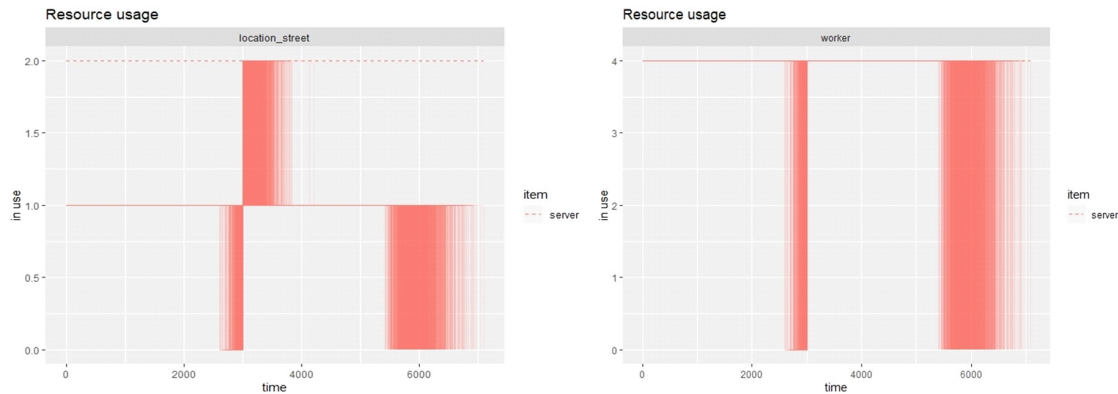

Figure 32: #6 Barcelona – Option 3 –Street location and construction worker usage

The results of the chosen construction option are provided as a JSON file to the ASHVIN platform for visualisation (Figure 33). Within the CMT tool, the comparison as-designed versus as-built can be compared in a split screen. On the one half of the screen the as-designed building process is depicted, as on the other half the as-built construction process is contrasted. Thus, the visualisations support comparison and understanding for project managers.

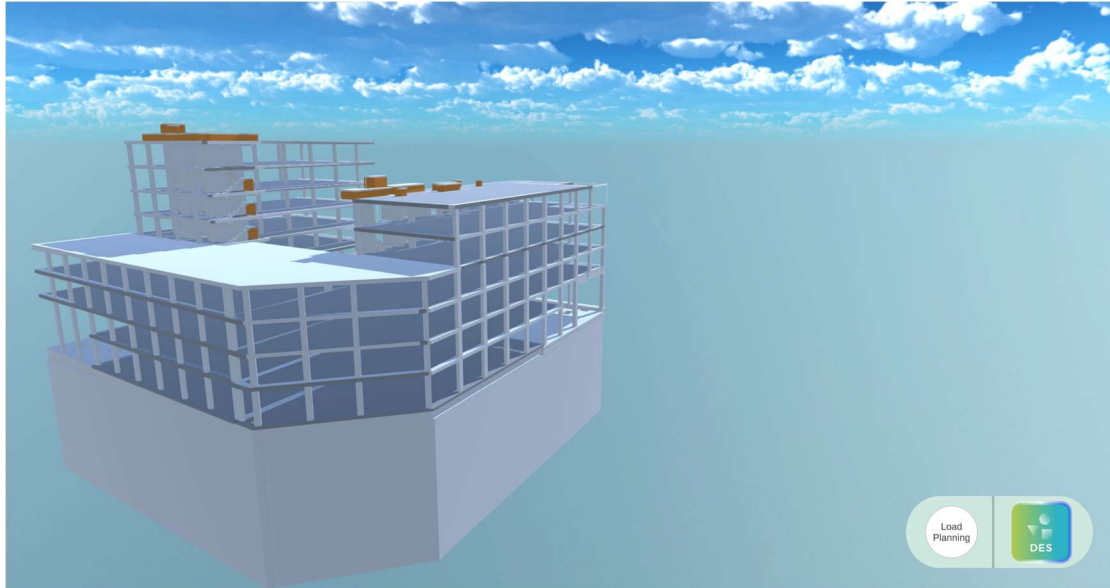

Figure 33: Visualisation on the ASHVIN platform #6 Barcelona

6 DISCUSSION

Within this deliverable, the potential of DTC is presented. In close alignment with the demonstration sites, various work process patterns were identified. Real-time data were collected during construction execution to gain knowledge about the as-performed process. This information can be used for management of ongoing

construction works by stochastic DES. With the help of the DES tool, the planning of construction works can be improved by applying Lean Construction principles. The construction works are structures by LBS and WBS according to T4.3. Supply chain by JIT delivery, resource allocations by providing continuous workflows, and site layouts due to simultaneous execution can be optimised due to the usage of the DES tool. This enables a more productive, resource-efficient, and safer construction execution. The DES tool can be used in planning meeting such as proposed by the Last Planner® System – a method for Lean Construction implementation (Ballard 2000). The Last Planner® System suggests holding weekly project meetings to analyse the executed work and adjust the workflow of construction works for the ongoing works according to Demming's PDSA cycle for continuous improvement of management processes (1993). Thus far, the discussions in planning meetings are based on paper-based, outdated documents (olde Scholenhuis et al. 2016) or subjective experiences of different stakeholders. Collecting real-time data on a construction site can provide accurate information about past activities and current site conditions (Hartmann 2021). Thus, meaningful and effective decisions can be made for the management of construction works based on reliable real-time data. It can be stated that this research presents the applicability of DTs within the construction phase and promotes research in the field of digitalisation and usage of DTC.

This research has some limitations. For the demonstration site in Gothenburg, Sweden, it was not possible to collect real-time data. Hence, for the finishing works process pattern, the PDFs are based on assumptions. The collection of real-time data is essential for the reliability of the DES tool. Nevertheless, this deliverable demonstrates the use of DES for finishing works planning. In a similar case study in Sweden, it was detected that the real duration of dry wall works differs by around 40 % from the average productivity standard determined by the Swedish union (Brosque et al. 2020). In general, it would be expedient for the future to continuously collect data from the start of construction until the end, like it was done on demonstration site #4 in Rinteln, Germany. Further aspects, which can be incorporated into the DES in the future, could be the experience or physical fatigue of construction workers. Additionally, it would be beneficial to collect data during material deliveries. It would be a straightforward way to gain insights regarding delivery durations and to use this information for improved management of construction works.

Within real-time DES, the focus is on the management of ongoing construction processes. But it is the duty of project leaders to manage not only the construction processes but the product itself as well (Hartmann et al. 2009). The DT concept enables to collect data regarding the as-built product and, thus, the quality of executed works can be investigated. E.g. the condition of the poured concrete on the demonstration site in Barcelona, Spain, was investigated by sensors and handled in the MatchFEM tool which will be described in D5.2. This emphasises the high-quality approach of the ASHVIN project for improved construction management based on real-time data.

7 REFERENCES

- Abbassi, S., Taghizade, K., and Noorzai, E. (2020). BIM-based Combination of Takt Time and Discrete Event Simulation for Implementing Just in Time in Construction Scheduling under Constraints. *Journal of Construction Engineering and Management*, 146 (12), 04020143-2.
- Abdelmegid, M. A., González, V. A., Poshdar, M., O'Sullivan, M., Walker, C. G., and Ying, F. (2020). Barriers to adopting simulation modelling in construction industry. *Automation in Construction*, 111, 103046.
- Akanmu, A. and Anumba, C. J. (2015). Cyber-physical systems integration of building information models and the physical construction. *Engineering, Construction and Architectural Management*, 22 (5), pp. 516-535.
- Akhavian, R., and Behzadan, A. H. (2013). Knowledge-based simulation modeling of construction fleet operations using multimodal-process data mining. *Journal of Construction Engineering Management*, 139 (11), 04013021.
- Akhavian, R., and Behzadan, A. H. (2014). Evaluation of queuing systems for knowledge-based simulation of construction processes. *Automation in Construction*, 47, pp. 37-49.
- Akhavian, R., and Behzadan, A. H. (2015). Construction equipment activity recognition for simulation input modelling using mobile sensors and machine learning classifiers. *Advanced Engineering Informatics*, 29, pp. 867-877.
- Akinci, B., Fischer, M., Levitt, R., and Carlson, R. (2002). Formalization and Automation of Time-Space Conflict Analysis. *Journal of Computing in Civil Engineering*, 16 (2), 124.
- ALICE Technologies Inc. (2022). <https://www.alicetechnologies.com/home>.
- Alshebani, M. N., Wedawatta, G. (2014). Making the Construction Industry Resilient to Extreme Weather: Lessons from Construction in Hot Weather Conditions. *Procedia Economics and Finance*, 18, pp. 635-642.
- Altaf, M. S., Bouferguene, A., Liu, H., Al-Hussein, M., and Yu, H. (2018). Integrated production planning for a pnaelized home prefabrication facility using simulation and RFID. *Automation in Construction* 85, pp. 369-383.
- Alvanchi, A., Baniassadi, F., Shahsavari, M, and Kashani, H. (2021). Improving materials logistics plan in road construction projects using discrete event simulation. *Engineering Construction & Architectural Management*, 28 (10), pp. 3144-3163.
- Ballard, G. (2000). *The Last Planner System of Production Control* (Dissertation). University of Birmingham, Birmingham, UK.
- Bandyopadhyay, P. S. and Forster, M. R. (2011). Philosophy of Statistics: An Introduction, In: Bandyopadhyay, P. S. and Forster, M. R. (editors), *Philosophy of Statistics*, Oxford: North Holland, pp. 1-52.
- Banks, J., Carson II, J. S., Nelson, B. L., and Nicol, D. M. (2010). *Discrete-Event System Simulation*, 5th edition, New Jersey: Pearson Education Inc.
- Bauer, D. F. (1972). Constructing Confidence Sets Using Rank Statistics. *Journal of the Statistical Association*, 67 (339), pp. 687-690.
- Behzadan, A. H., Menassa, C. C., and Pradhan, A. R. (2015). Enabling real time simulation of architecture, engineering, construction, and facility management (AEC/FM) systems: a review of formalism, model architecture, and data representation. *Journal of Information Technology in Construction*, 20, pp. 1-23.
- Biau, D. J., Jolles, B. M., and Porcher, R. (2010). P value and the Theory of Hypothesis Testing: An Explanation for new Researchers. *Clinical Orthopaedics and Related Research*, 468 (3), pp. 885-892.
- Bilal, M., Oyedele, L. O., Qadir, J., Munir, K., Ajayi, S. O., Akinade, O. O., Owolabi, H. A., Alaka, H. A, and Pasha, M. (2016). Big Data in the construction industry: A review of present status, opportunities, and futures trends. *Advanced Engineering Informatics*, 30 (3), pp. 500-521.

- Blair, R. C. and J. J. Higgins. (1980). A comparison of the Power of Wilcoxon's Rank-Sum Statistic to that of Student's t Statistic Under Various Nonnormal distributions. *Journal of Educational Statistics* 5 (4), pp. 309-335.
- Bokor, O., Florez, L., Osborne, A., and Gledson, B. J. (2019). Overview of construction simulation approaches to model construction processes. *Organization, Technology and Management in Construction*, 11, pp. 1853-1861.
- Braun, H. (1980). A Simple Method for Testing Goodness of Fit in the Presence of Nuisance Parameters. *Journal of the Royal Statistical Society*, 42 (1), pp. 53-63.
- Brilakis, I., Pan, Y., Borrmann, A., Mayer, H.-G., Vos, C., Pettinato, E., and Wagner, S. (2019). Built Environment Digital Twinning, Report for the International Workshop on Built Environment Digital Twinning.
- Brosque, C., Skeie, G., Örn, J., Jacobson, J., Lau, T., and Fischer, M. (2020). Comparison of Construction Robots and Traditional Methods for Drilling, Drywall, and Layout Tasks. *International Congress on Humam-Computer Interaction, Optimization and Robotic Applications (HORA)*, pp. 1-14.
- Buildots (2022). <https://buildots.com>.
- Burnham, K. P. and Anderson, D. R. (2002). *Model Selection and Multimodel Inference: A Practical Information-Theoretic Approach*, 2nd edition, New York: Springer.
- Chan, A. P. C. and Chan, A. P. L. (2004). Key performance indicators for measuring construction success. *Benchmarking: An International Journal* Vol. 11 No.2, pp. 203-221.
- Cheng, C. F., Rashidi, A., Davenport, M. A., Anderson, D. V., and Sabillon, C. (2018). Software and hardware requirements for audio-based analysis of construction operations.
- Craparo, R. M. (2007). Significance level. In: Salkind, N. J. (editor), *Encyclopedia of Measurement and Statistics*. Vol. 3, Thousand Oaks: SAGE publications, pp. 889-891.
- Dallasega, P., Rauch, E., and Linder, C. (2018). Industry 4.0 as an enabler for proximity for construction supply chains: A systematic literature review. *Computers in Industry*, 99, pp. 205-225.
- Dave, B., Hämäläinen, J.-P., Kemmer, S., Koskela, L., and Koskenvesa, A. (2015). Suggestions to Improve Lean Construction Planning. In: *Proceedings of the 23rd Annual Conference of the International Group for Lean Construction*, pp. 193-202.
- Dave, B., Kubler, S., Främpling, K., and Koskela, L. (2016). Opportunities for enhanced lean construction management using Internet of Things standards. *Automation in Construction* 61, pp. 86-97.
- Delignette-Muller, M. L., and Dutang, C. (2015). Fitdistrplus: An R package for Fitting Distributions. *Journal of Statistical Software*, 64 (4), pp. 1-34.
- Demming, W. E. (1993). *The New Economics for Industry, Government, Education*. Second edition. Massachusetts Institute of Technology Press.
- Deng, M., Menassa, C.C., and Kamat, V. R. (2021). From BIM to digital twins: A Systematic review of the evolution of intelligent building representations in the AEC-FM industry. *Journal of Information Technology in Construction*. 26, pp. 58-83.
- Durdyev, S., and Hosseini, M. R. (2020). Causes of delays on construction projects: a comprehensive list. *International Journal of Managing Projects in Business*, 13 (1), pp. 20-46.
- EURACTIV, Digitising the EU's construction industry, Manifesto Report 6, Jan.-Mar. 2019.
- European Construction Sector Observatory (ECSO). (2021). Digitalisation in the construction sector – Analytical Report.
- Eurostat (2021). Labour cost levels by NACE Rev. 2 activity, https://ec.europa.eu/eurostat/databrowser/view/lc_lci_lev/default/table?lang=en.
- Eurostat (2022). Fatal and non-fatal accidents at work by NACE section, EU, https://ec.europa.eu/eurostat/statistics-explained/index.php?title=Accidents_at_work_statistics#Analysis_by_activity.
- Flair 3D (2021). <https://flair3d.com>.

- Gao, T., Ergan, S., Akinci, B., Garrett, J.H. (2014). Proactive productivity management at job sites: understanding characteristics of assumptions made for construction processes during planning based on case studies and interviews. *Journal of Construction, Engineering and Management*, 140 (3), 4013054.
- Ganeshand, R. and Harrison, T. P. (1995). *An Introduction to Supply Chain Management*.
- Goldbeck (2021). Goldbeck Webcam: <https://goldbeck444.hi-res-cam.com>.
- Halpin, D. W. and Riggs, L. S. (1992). *Planning and Analysis of Construction Operations*. New York: John Wiley Inc. & Sons, Inc.
- Hartmann, T., Fischer, M., and Haymaker, J. (2009). Implementing information systems with project teams using ethnographic-action research. *Advanced Engineering Informatics* 23, pp. 57-67.
- Hartmann, T. (2021). Virtual construction with digital twins – The key for leanly planned complex construction systems. *Kongress Zukunft Bau Wien, Vienna Austria*.
- Heaton, R., Martin, H., Chadee, A., Milling, A., Dunne, S., and Borthwick, F. (2022). The Construction Materials Conundrum: Practical Solutions to Address Integrated Supply Chain Complexities. *Journal of Construction Engineering and Management* 148 (8), 04022071.
- Hollander, M., Wolfe, D. A., and Chicken, E. (2013). A Distribution-Free Signed Rank Test (WILCOXON). In: *Nonparametric Statistical Methods*, 3rd edition, New Jersey: John Wiley & Sons Inc., pp. 40-55.
- Jiang, F., Ma, L., Broyd, T., and Chen, K. (2021). Digital twin and its implementation in the civil engineering sector. *Automation in Construction*, 130, 103838.
- Jin, L., Liu, H., Zheng, X., and Chen, S. (2020). Exploring the Impact of Wind Loads on Tower Crane Operation. *Mathematical Problems in Engineering*, 2807438.
- Khajavi, S. H., Motlagh, N., H., Jaribion, A., Werner, L.C., and Holmstrom, J. (2019). Digital twin: vision, benefits, boundaries, and creation for buildings. *IEEE Access*, 7, pp. 147406–147419.
- König, M., Koch, C., Habenicht, I., and Spieckermann, S. (2012). Intelligent BIM-Based Construction Scheduling using Discrete Event Simulation, in: *Proceedings of the Winter Simulation Conference 2012*, pp. 1-12.
- Koskela, L. J. (1999). Management of production in construction: a theoretical view. In: *7th Annual Conference of the International Group for Lean Construction*, pp. 241–252.
- Larsson, J., Lu, W., Krantz, J., and Olofsson, T. (2016). Discrete Event Simulation Analysis of Product and Process Platforms: A Bridge Construction Case Study. *Journal of Construction Engineering and Management*, 142 (4), 4015097.
- Lee, S., Behzadan, A., Kandil, A. and Mohamed, Y. (2013). Grand Challenges in Simulation for the Architecture, Engineering, Construction, and Facility Management Industries. *ASCE International Workshop on Computing in Civil Engineering*, pp. 773-785.
- Leite, F., Cho, Y. K., and Behzadan, A. H. (2016). Visualization, Information Modeling and Simulation: Grand Challenges in the Construction Industry. *Journal of Computing in Civil Engineering*, 30 (6), 04016035.
- Lin, P. C., Wang, J., Huang, S. H., and Wang, Y.-T. (2010). Dispatching ready mixed concrete trucks under demand postponement and weight limit regulation. *Automation in Construction*, 19, pp. 798-807.
- Liu, H., Altaf, M. S., Lei, Z., Lu, M., and Al-Hussein, M. (2015). Automated production planning in panelized construction enabled by integrating discrete-event simulation in BIM. *Conference: The Canadian Society for Civil Engineering 5th International/11th Speciality Conference*.
- Lu, W., Chen, K., Xue, F., and Pan, W. (2018). Searching for an optimal level of prefabrication in construction: An analytical framework. *Journal of Cleaner Production* 201, pp. 236-245.
- Łukaszewska, A., Giluń, M., Bąk, M., Johansson, F., Jongeling, R., Tomar, R., Claeson-Jonsson, C., Jungmann, M., Campos, J., Gonçalves, J., Papanikolaou, V., Chacon, R., and Ungureanu, L. (2021a). D4.1 A set of KPIs to plan and monitor productive, resource efficient, and safe construction sites.
- Łukaszewska, A., Jongeling, R., Tomar, R., Claeson-Jonsson, C., Jungmann, M., Campos, J., Gonçalves, J., Papanikolaou, V., Chacon, R., García Carrera, D., Ramonell, C., Posada, H., Ungureanu, L., Skaric Palic, S., Stipanovic, I., and Krenn, B. (2021b). D.7.1 ASHVIN technology demonstration plan.

- Marsaglia, G., Tsang, W. W., and Wang, J. (2003). Evaluating Kolmogorov's Distribution. *Journal of Statistical Software*, 8 (18), pp. 1-4.
- Martinez, J. C. (2010). Methodology for Conducting Discrete-Event Simulation Studies in Construction Engineering and Management. *Journal of Construction Engineering and Management*, 136 (1), pp. 3-16.
- Massey Jr., F. J. (1951). The Kolmogorov-Smirnov test for goodness of fit. *Journal of the American statistical Association*, 46 (253), pp. 68-78.
- Moda, H. M. and Minhas, A. (2019). Impacts of Climate Change on Outdoor Workers and Their Safety: Some Research Priorities. *IJERPH*, 16, 3458.
- Naylor, T. H. and Finger, J. M. (1967). Verification of Computer Simulation Models. *Management Science*, 14(2), pp.: B92-B106.
- Ng, T., Zheng, D. X. M., and Xie, J. Z. (2013). Allocation of resources through a pull-driven approach. *Construction Innovation*, 13 (1), pp. 77-79.
- olde Schultenhuis, L. L., Hartmann, T., and Dorée, A. G. (2016). 4D CAD Based Method for Supporting Construction Coordination of Urban Subsurface Utility Projects. *Automation in Construction* 62, pp. 66-77 (2016).
- Peng, B., Flager, F. I., and Wu, J. (2018). A method to optimize mobile crane and crew interactions to minimize construction cost and time. *Automation in Construction*, 95, pp. 10-19.
- Rashid, K. M. and Louis, J. (2022). Integrating Process Mining with Discrete-Event Simulation for Dynamic Productivity Estimation in Heavy Civil Construction Operations. *Algorithms*, 15, 173.
- RazaviAlavi, S., and AbouRisk, S. (2021). Construction Site Layout Planning Using a Simulation-Based Decision Support Tool. *Logistics*, 5, 65.
- Research and Markets (2021). Report: Prefabricated Building Market in Europe – Industry Outlook and Forecast 2021-2026.
- Roberts, D., and Golparvar-Fard, M. (2019). End-to-end vision-based detection, tracking and activity analysis of earthmoving equipment filmed at ground level. *Automation in Construction*, 105, 102811.
- Robinson, S. (2005). Discrete-event simulation: from the pioneers to the present, what next?. *Journal of the Operational Research Society*, 56 (6), pp. 619-629.
- Sacks, R., Brilakis, I., Pikas, E., Xie, H. S., and Girolami, M. (2020). Construction with digital twin information systems. *Data-Centric Engineering*, 1, E14.
- Sargent, R.G. (2017). A perspective on fifty-five years of the evolution of scientific respect for simulation. In: *Winter Simulation Conference 2017*, pp. 3–15.
- Seppänen, O, Modrich, R.-U., and Ballard, G. (2015). Integration of Last Planner System and Location-Based Management System. In: *Conference 23rd Annual Conference of the International Group of Lean Construction*, Perth, Australia, pp. 123-132.
- Sherafat, B., Ahn, C. R., Akhavian, R., Behzadan, A. H., Golparvar-Fard, M., Kim, H., Lee, Y.-C., Rashidi, A., and Azar, E. R. (2020). Automated Methods for Activity Recognition of Construction Workers and Equipment: State-of-the-Art Review. *Journal of Construction Engineering and Management*, 146 (6), 03120002.
- SINC Business Corporation (2022). <https://sinc.business>.
- Slaton, T., Hernandez, C., and Akhavian, R. (2020). Construction activity recognition with convolutional recurrent networks. *Automation in Construction*, 113, 103138.
- SN-online (2020). Schaumburger Nachrichten: <https://www.sn-online.de/lokales/schaumburg/rinteln/hier-entstehen-in-rinteln-neue-arbeitsplaetze-und-millionen-pizzakartons-IMZCTXRLMX7SQXGA4UY6MPDPTE.html>.
- Stephens, M. A. (1986). Tests based on EDF Statistics, In: D'Agostino, R. B. and Stephens, M. A. (editors), *Goodness-of-Fit Techniques*, New York: Marcel Dekker Inc., pp. 97-194.
- Tao, F., Sui, F., Liu, A., Qi, Q., Zhang, M., Song, B., Guo, Z., Lu, S. C. Y., and Nee, A. Y. C. (2019). Digital twin-driven product design framework. *International Journal of Production Research*, 57 (12), pp. 3935-3953.

- Teodorović, M., Hartmann, T., Tomar, R., Koulalis, I., Pridmore, J., Gavin, K., and Chacón, R. (2020). D1.1 Launch Version of the ASHVIN Platform.
- Thomopoulos, N. T. (2018). *Probability Distributions*. Cham, Switzerland: Springer.
- Ungureanu, L., Hartmann, T., and Serbanoiu, I. (2019). Quantitative lean assessment of line of balance schedules` quality. *Engineering, Construction and Architectural Management*, 26 (2), pp. 224-244.
- VisiLean (2022). <https://visilean.com>.
- Wainer, G. A. (2009). *Discrete-Event Modeling and Simulation: A Practitioner's Approach*, Boca Raton: CRC Press.
- Wainer, G.A., Mosterman, P.J. (2016). *Discrete-Event Modeling and Simulation: Theory and Applications*. CRC Press.
- Wang, D., J. Chen, D. Zhao, F. Dai, C. Zheng, and X. Wu. (2017). Monitoring workers' attention and vigilance in construction activities through a wireless and wearable electroencephalography system. *Automation in Construction*, 82, pp. 122–137.
- Winge, S., Albrechtsen, E., Arnesen, J. (2019). A comparative analysis of safety management and safety performance in twelve construction projects. *Journal of Safety Research*, 71, pp. 139-152.
- Xue, J., Hou, X., and Zeng, Y. (2021). Review of Image-Based 3D Reconstruction of Building for Automated Construction Progress Monitoring. *Applied Sciences*, 11(17), 7840.
- Zeigler, B. P. (1976). *Theory of Modelling and Simulation*. New York: Wiley-Interscience.
- Zeigler, B. P., Praehofer, H., and Kim, T. G. (2000). *Theory of Modelling and Simulation*, 2nd ed. New York: Academic Press.
- Zeigler, B. P. (2011). Foreword. In: Wainer, G. A. and Mostermann, P. J. (editors), *Discrete-Event Modelling and Simulation Theory and Applications*, Boca Raton: CRC Press.
- Zeigler, B. P., Muzy, A., and Kofman, E. (2018). *Theory of Modeling and Simulation*, 3rd edition, Academic Press.