

Fuzzy membership functions tuning for speed controller of induction motor drive: performance improvement

Nabil Farah¹, Md Hairul Nizam Talib², Zulkifilie Bin Ibrahim³, Qazwan Abdullah⁴, Ömer Aydoğdu⁵,
Jurifa Mat Lazi⁶, Zm Isa⁷

^{1,2,3,6,7}Fakulti Kejuruteraan Elektrik, Universiti Teknikal Malaysia Melaka, Malaysia

^{4,5}Faculty of Engineering and Natural Sciences, Konya Technical University, Turkey

⁷Fakulti Teknologi Kejuruteraan Elektrik, Universiti Malaysia Perlis, Perlis, Malaysia

Article Info

Article history:

Received May 9, 2021

Revised Jun 19, 2021

Accepted July 29, 2021

Keywords:

FLC

Fuzzy logic

IM

Membership functions

MFs tuning

Performance improvement

ABSTRACT

Fuzzy logic controller (FLC) has gained high interest in the field of speed control of machine drives in both academic and industrial communities. This is due to the features of FLC of handling non-linearity and variations. FLC system consists of three main elements: scaling factors (SFs), membership functions (MFs), and rule-base. Fuzzy MFs can be designed with different types and sizes. For induction motor (IM) speed control, (3x3), (5x5) and (7x7) MFs are the most used MFs sizes, and normally designed based on symmetrical distribution. However, changing the width and peak position of MFs design enhance the performance. In this paper, tuning of MFs of FLC speed control of IM drives is considered. Considering (3x3), (5x5) and (7x7) MFs sizes, the widths and peak positions of these MFs are asymmetrically distributed to improve the performance of IM drive. Based on these MFs sizes, the widths and peak positions are moved toward the origin (zero), negative and positive side that produces a controller less sensitive to the small error variations. Based on simulation and performance evaluations, improvement of 5% in settling time (T_s), 0.5% in rise time and 20% of steady-state improvement achieved with the tuned MFs compared to original MFs.

This is an open access article under the [CC BY-SA](https://creativecommons.org/licenses/by-sa/4.0/) license.



Corresponding Authors:

Nabil Farah and M. H. N Talib

Fakulti Kejuruteraan Elektrik

Universiti Teknikal Malaysia Melaka

Jalan Hang Tuah Jaya, 76100 Durian Tunggal, Melaka, Malaysia

Email: nabil-farah11@hotmail.com, hairulnizam@utem.edu.my

1. INTRODUCTION

Induction motor (IM) mainly converts electrical energy into mechanical energy and intensively being used in various industrial and residential applications [1], [2]. This is due to its rugged construction, robust operation, and cheap cost. IM control firstly was achieved based on V/F control method [3], then vector control method was introduced as an advanced IM drive technique that allows stator flux and electromagnetic torque decoupling [4], [5]. Vector control enables IM drive to be controlled like separately excited DC machines with fast transient response and good steady-state performance [6]. There are two types of vector control namely: indirect field oriented control (IFOC) and direct torque control (DTC). FOC works by decoupling stator currents into flux and torque (d-q axis) components, and control them independently [7]-[9]. While DTC works based on a predefined switching table to generate switching pulses [10]. Besides vector control methods, model predictive control (MPC) has been recently proposed with a simple design, multi variables control, fast transient behavior and handling non-linearity restrictions [11]-[13].

Speed control is one of the main element of IM drive which need to be controlled effectively to obtain good performance. For decades, proportional integral (PI) controller has been the choice for speed control of IM drive due to its design simplicity and ability to obtain a fast dynamic response with appropriate tuning [14], [15]. However, due to the nature of PI with fixed gains, the drive performance can be degraded in case of parameters change, speed variations, and load disturbance [16]. Thus, a more robust controller is required that can adapt to changes in the drive system [17]. Fuzzy logic controller (FLC) has been proposed as an intelligent speed controller due to its ability to handle system non-linearity, parameter changes, and speed variations [18], [19]. The significant features of FLC tend to make it a better alternative for PI controller in vector control of IM drives [17]. The operational structure of FLC implies its ability to work in a similar way to human decision-making [20]. FLC speed controller consists of two inputs and one output variables, each variable is mapped with membership functions to cover its range. Fuzzy rule-base then constructed based on expert system knowledge to decide the fuzzy output based on the current inputs [21]. Normally, FLC parameters including scaling factors (SF), membership functions (MF), and rule-base are designed based on nominal operating conditions of the motor [22]. But, if the motor operates far away from the nominal operating conditions, FLC parameters might not be adequate to keep the good performance of the motor drive [23], [24]. To solve this issue, various tuning methods were proposed to update the FLC parameters in accordance to any system changes [25], [26]. Self-tuning mechanism to tune the scaling factors of FLC were proposed in different literature including [22], [25], [27]. Moreover, FLC rule-base modification and simplification to maintain good drive performance in all conditions have been discussed in [26], [28]-[31]. Besides, fuzzy MFs play important role in shaping the output performance of the drive system. MFs can be in different shapes and sizes such as triangular, trapezoidal shapes, and (3x3), (5x5), (7x7) sizes. Triangular and trapezoidal MFs shapes are most commonly used due to less computational burden [32], also (3x3,5x5,7x7) MFs sizes are the most standard MFs sizes for speed control of induction motor, increasing the number of MFs beyond this does not show any significance [17], [33]. Normally, MFs are designed based on equally distributed ranges, but for performance enhancement, MFs can be distributed asymmetrically based on the application requirements. Thus, FLC MFs tuning and adjustment have been discussed in [32], [34], [35] to improve the performance of IM drives. In many literature, normally the width and position of the MFs are symmetrically designed. However, effectively changing the width and peak position of the MFs can enhance the performance of the IM drives. A study in [36] has tuned the width of 7x7 MFs for IM drive and showed enhanced performance compared to the original symmetrical MFs. However, the study focused on tuning the width of 7x7 MFs only. There is lack of studies of investigating the significance of tuning MFs on the IM drive performance with detailed analysis and different MFs sizes.

In this study, a detailed investigation of the effects of tuning MFs on the performance of IM drive considering different MFs sizes will be presented. Three different MFs (3x3, 5x5, and 7x7) sizes will be tuned by changing their widths and peak positions for performance improvement. The three MFs sizes will be asymmetrically distributed by moving their peak positions and widths toward the zero (origin), negative and positive side, thus obtaining a robust controller less sensitive to the small error variations. The MFs tuning process along with performance comparisons and analyses with the original MFs will be presented. This is validated by performing simulation testing using Matlab/Simulink based on Indirect FOC of IM drive. The rest of the paper is organized as follow: section 2 presents the mathematical modelling of IM, section 3 discusses FLC speed control design, section 4 discusses FLC MFs tuning, section 5 discusses simulation result and analyses and lastly section 6 outlines the findings and outcomes achieved.

2. INDUCTION MOTOR MODELLING

A dynamic model of a machine must be accurately obtained in order to design an effective drive system. Such a model can be derived employing two-axis theory (d-q) of electrical machines. There are different reference frames which can be used to model the IM such as stationary, rotary, or synchronous reference frames [37], [38]. According to the equivalent circuit of IM as shown in Figure 1, the voltage quantities can be expressed as follow:

$$V_{ds} = R_s i_{ds} + \frac{d\phi_{ds}}{dt} - \omega_e \phi_{qs} \quad (1)$$

$$V_{qs} = R_s i_{qs} + \frac{d\phi_{qs}}{dt} + \omega_e \phi_{ds} \quad (2)$$

$$V_{dr} = R_r i_{dr} + \frac{d\phi_{dr}}{dt} - (\omega_e - \omega_r) \phi_{qr} \quad (3)$$

$$V_{qr} = R_r i_{qr} + \frac{d\phi_{qr}}{dt} + (\omega_e - \omega_r) \phi_{dr} \quad (4)$$

Besides, the Flux equations can be expressed as:

$$\varphi_{ds} = L_{ls}i_{ds} + L_m i_{dr} \tag{5}$$

$$\varphi_{qs} = L_{ls}i_{qs} + L_m i_{qr} \tag{6}$$

$$\varphi_{dr} = L_m i_{ds} + L_{lr}i_{dr} \tag{7}$$

$$\varphi_{qr} = L_m i_{qs} + L_{lr}i_{qr} \tag{8}$$

where V_{sd} , \bar{V}_{sq} are the stator voltages; i_{ds} , i_{qs} , i_{dr} , i_{qr} are the d and q axis stator current and rotor currents. φ_{ds} , φ_{qs} , φ_{dr} , φ_{qr} are the stator and rotor flux. R_s , R_r are the stator and rotor resistances. L_{ls} , L_{lr} denotes stator and rotor inductances, whereas L_m is the mutual inductance.

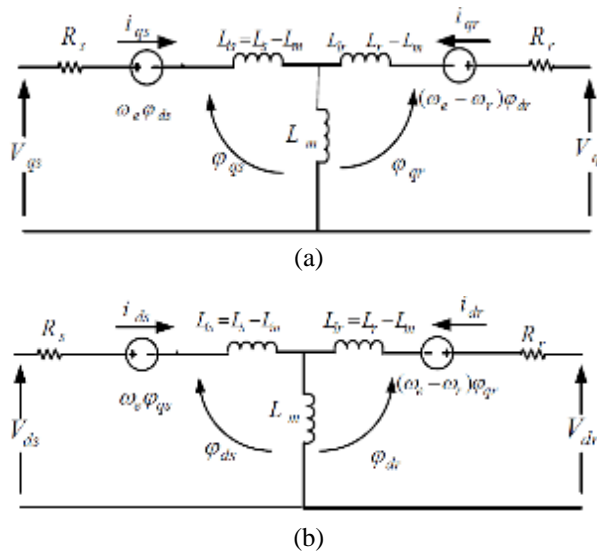

Figure 1. Dynamic or d-q equivalent circuit of induction machine; (a) q-axis circuit; (b) d-axis circuit

For a singly-fed machine, such as cage motor, $V_{dr} = V_{qr} = 0$. The rotor speed ω_r cannot normally treat as a constant. It can be related to torque as:

$$T_e = T_L + J \frac{d\omega_m}{dt} = T_L + \frac{2}{p} J \frac{d\omega_m}{dt} \tag{9}$$

where T_L = load torque, J =rotor inertia, and ω_m = mechanical speed.

Indirect FOC is based on projections where a three-phase time-invariant and speed-dependent system is transformed into a two-coordinate, d-q time-invariant system which is similar to the DC motor principle [39]. By representing the IM model in a rotating synchronous reference frame, the torque component represented by i_{qs} and flux component represented by i_{ds} , the voltage equations are:

$$\frac{d\varphi_{dr}}{dt} = -\frac{1}{\tau_r} \varphi_{dr} + (\omega_e - \omega_r)\varphi_{qr} + \frac{L_m}{\tau_r} i_{ds} \tag{10}$$

$$\frac{d\varphi_{qr}}{dt} = -\frac{1}{\tau_r} \varphi_{qr} - (\omega_e - \omega_r)\varphi_{dr} + \frac{L_m}{\tau_r} i_{qs} \tag{11}$$

$\varphi_{rq} = 0$ and $\varphi_{rd} = \varphi_r$ when the rotor flux is locked to the d-axis, hence yielding the new expression,

$$\varphi_r = \frac{L_m}{\tau_r s + 1} i_{ds} \tag{12}$$

$$(\omega_e - \omega_r) = \omega_{sl} = \frac{L_m i_{sq}}{\tau_r \phi_r} \tag{13}$$

With $\tau_r = \frac{L_r}{R_r}$ is the rotor time constant. According to (12), the value of the rotor flux, ϕ_r is driven by stator flux direct axis current i_{ds} . The electrical torque of the motor can be as expressed in the (14).

$$T_e = \frac{3 P L_m^2}{2 L_r} \phi_{dr} i_{qs} \tag{14}$$

IM drive-based IFOC consists of an IM model, fuzzy logic speed controller, phase transformation, hysteresis current controller (HCC), and three-phase voltage source inverter (VSI). The overall IM drive system incorporating IFOC is depicted in Figure 2. The IM drive works by firstly measuring the rotor speed and stator currents, then fed the signals to the speed controller as well as current control so switching signals can be generated through hysteresis current control (HCC) to control the VSI which produces 3-phase voltage to operate the motor.

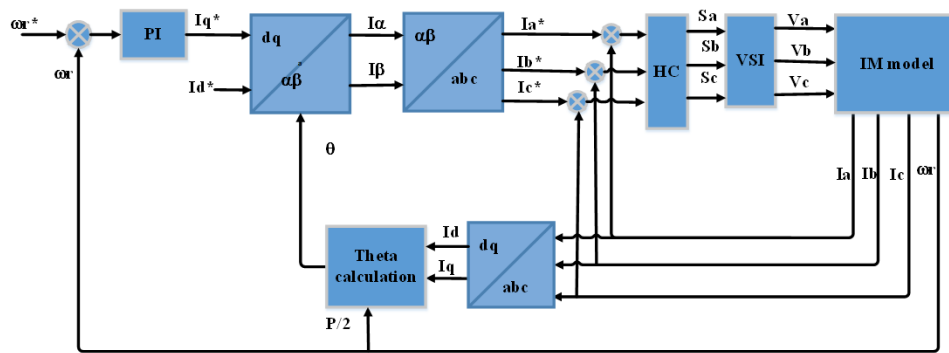

Figure 2. Overall block diagram of IM drive system

3. FUZZY LOGIC SPEED CONTROLLER

Fuzzy logic controller (FLC) is an intelligent control technique that can emulate the way of human-decision making. FLC speed controller has three main elements, scaling factors (SF), rule-base, and membership functions (MFs). The architecture of FLC consists of three operational tasks which are pre-processing, processing, and post-processing. In the pre-processing stage, the input linguistic variables are converted (fuzzified) into fuzzy variables through input MFs, this called fuzzification. In the processing, the fuzzy rules are executed to produce fuzzy output. In the post-processing stage, the output fuzzy variable is converted (defuzzified) into a linguistic variable through output MFs [40], [41]. The structure of the FLC speed controller with two inputs (e , Δe) and one output (Δu) Figure 3.

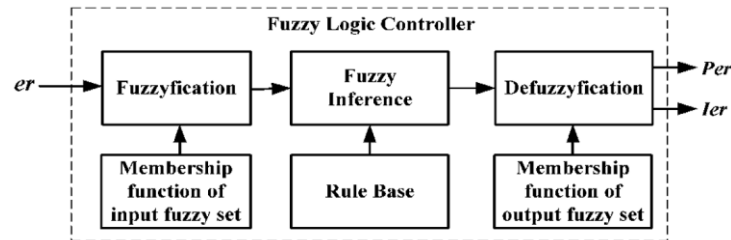

Figure 3. Fuzzy logic block diagram

3.1. Scaling factors (SFs)

Scaling factor (SF) is a parameter gain used to adjust the value of the fuzzy variable into a normalized range. FLC speed controller has three SFs, speed error SF (G_e), change of speed error SF (G_{ce}), and change of output SF (G_{cu}). The values of SFs are pre-calculated based on the nominal condition of the motor. The value of G_e for 2hp IM with the parameters can be calculated based on the rated speed. The rated

speed of the motor is 1430 rpm and considering forward and reverse operation, it will be multiplied by constant 2 [28]:

$$G_e = \frac{1}{|2\omega_{e\max}|} = \frac{1}{2 \times 1430} = 0.00034 \tag{15}$$

The value of G_{ce} can be calculated using the maximum torque equation [42], however, in this paper, the value of G_{ce} , as well as the value of G_{cu} , are set to ideal value (1) and maintain constant for all simulation. Besides, SFs values can be obtained by a self-tuning mechanism that can compute the value automatically during the operation. Many studies have proposed a self-tuning mechanism particularly for output SF (G_{cu}) due to its significance on performance [22], [25], [43], [44].

3.1.1. Rule-base

A fuzzy rule-base is a set of IF-THEN statements used to decide the output fuzzy state based on its input state [45], [46]. Considering FLC speed control with two inputs (e , Δe) and one output (Δu), the rule-base in the form:

$$Rule_n = IF\ e\ is\ A_n\ And\ \Delta e\ is\ B_n\ Then\ \Delta u\ is\ C_n$$

Where, n is the number of rules, A , B , and C are the membership function names which can be replaced by the negative large (NL), negative medium (NM), negative small (NS), zero (ZE), positive small (PS), positive medium (PM) and positive large (PL). There three different standard rule-base FLC for speed control of IM drive [33] which are 9-rule (3x3MFs), 25-rule (5x5MFs), and 49-rule (7x7MFs). The rule-base is selected based on engineering knowledge and system-expert, rule base of 3x3, 5x5 and 7x7 FLC are in Tables 1, 2, and 3 [45], [47].

Table 1. 3x3 MFs rule-base

		NL	ZE	PL
	e			
Δe	NL	NL	NL	ZE
	ZE	NL	ZE	PL
	PL	ZE	PL	PL

Table 2. 5x5 MFs rule-base

	E	NL	NS	ZE	PS	PL
	Δe					
	NL	NL	NL	PS	NS	ZE
	NS	NL	NS	NS	ZE	PS
	ZE	NL	NS	NS	PS	PL
	PS	NS	ZE	ZE	PS	PL
	PL	ZE	PS	PS	PL	PL

Table 3. 7x7 MFs rule-base

	e	NL	NM	NS	ZE	PS	PM	PL
Δe								
	PL	ZE	PS	PS	PL	PL	PL	PL
	PM	NS	ZE	PS	PM	PL	PL	PL
	PS	NS	NS	ZE	PS	PS	PL	PL
	ZE	NL	NM	NS	ZE	PS	PM	PL
	NS	NL	NL	NS	NS	ZE	PS	PS
	NM	NL	NL	NL	NM	NS	ZE	PS
	NL	NL	NL	NL	NL	NS	NS	ZE

3.1.2. Membership functions

Membership functions (MFs) are a graphical representation of the range of the fuzzy variable. It divides the range into different widths based on the number of MFs being used. In terms of MFs shape, there are different types of MFs including triangular, trapezoidal, sigmoidal, Gaussian, Z-shape, and S-shape MFs [48]. The most commonly used MFs in FLC speed control are triangular and trapezoidal MFs due to their high

accuracy and less computational complexity compared to other MFs [32], [36]. In this research, only triangular MFs will be considered and the center of gravity (CoG) algorithm is used as the fuzzification technique. There are three popular triangular MFs sizes namely; 3x3, 5x5, and 7x7 MFs. If the width and position of these MFs are symmetrically designed, their shape will be as shown in Figure 4. As can be seen in Figure 4, the width and position of MFs are symmetrical in which the width between each MF is equally distributed. The current shape of MFs is referred as the standard MFs, but effectively changing the width and peak position of MFs may lead to enhancing the performance of the drive system. Therefore, tuning MFs can be done with asymmetrical distribution of the width and peak position of MFs which will be discussed in the next section.

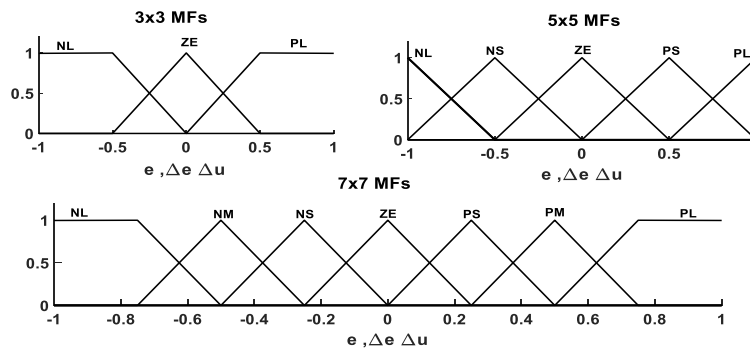

Figure 4. FLC MFs of inputs and output for 3x3, 5x5, and 7x7 sizes

4. MEMBERSHIP FUNCTIONS TUNINGS

The width and position of the membership functions are normally symmetrically designed. In order to improve the dynamic performance of the IM drive, the width and peak position of the MFs can be changed. The speed error MFs are adjusted to enhance the drive performance particularly in the proximity of the origin point. Considering 3x3 MFs and adjusting the width and peak position of NL and PL toward ZE for input fuzzy error (e) and changing the width of ZE for input change of error (Δe) and change of output (Δu) as shown in Figure 5.

In addition, changing the peak values positions of the error (e) MFs (PL, NL) toward the negative side and narrowing down the width of ZE will produce a speed controller highly sensitive to small error negative variation. Also, change of error (Δe) and change of output (Δu) can be adjusted by changing the peak position of PL toward the positive side, NL toward the negative side, and narrowing down the width of ZE for both. The tuned 3x3 MFs for error (e), change of error (Δe), and change of output (Δu) are shown in Figure 5.

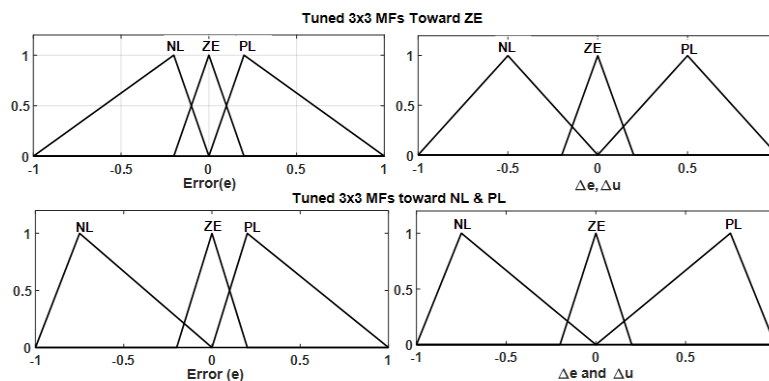

Figure 5. Tuned 3x3 MFs toward, ZE and (PL, NL) for error, change of error and change of output fuzzy

Considering 5x5 MFs and adjusting the width and changing the peak values position of the MFs (NS, PS) to the ZE side for error (e) and narrowing down the width of ZE for both error (e), change of error (Δe) and change of output (Δu). This can enhance the effectiveness of the speed response with a faster dynamic response and smaller overshoot. Apart from that, changing the peak values position of the MFs (NS,

PS) to the NL side for error (e), changing the peak values and position of the MFs ((NS) toward the NL and (PS) toward (PL) for change of error (Δe) and change of output (Δu) and narrowing down the width of ZE for both error (e), change of error (Δe) and change of output (Δu). This can also improve the dynamic response of the system. The tuned 5 x 5 MFs of error (e), change of error (Δe), and change of output (Δu) are presented in Figure 6 for MFs tuned to ZE and MFs tuned to (NL, PL).

Similarly, for 7x7 MFs the peak position of MFs (NM, NS, PS, and PM) can be shifted toward zero and MFs (ZE) width can be narrowed down in order to produce effective speed control with faster transient response and stable steady-state response. In addition, the peak positions of the peak position of MFs (NM, NS, PS, and PM) can be shifted toward NL for error (e), while the MFs (NM, NS) can be shifted toward NL and (PS, PM) toward PL for change of error (Δe) and change of output (Δu). The width of ZE is narrowed down in both cases to make the speed controller highly sensitive to small speed variations. The adjusted 7x7 MFs for error (e), change of error (Δe), and change of output (Δu) toward ZE and (NL, PL) are shown in Figures 7.

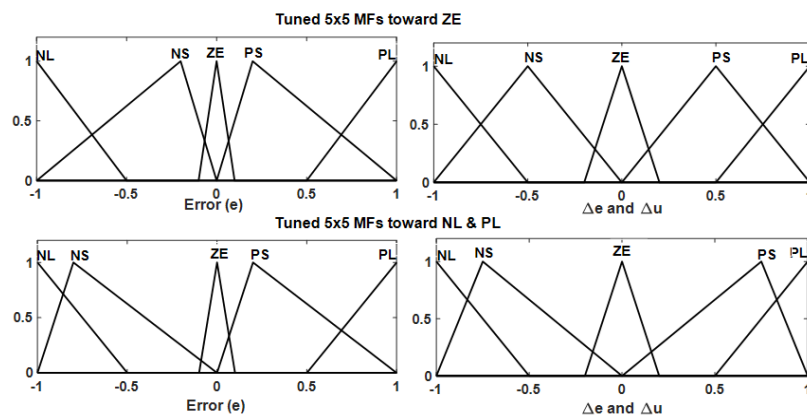

Figure 6. Tuned MFs toward ZE and (PL, NL) for error, change of error, and output fuzzy

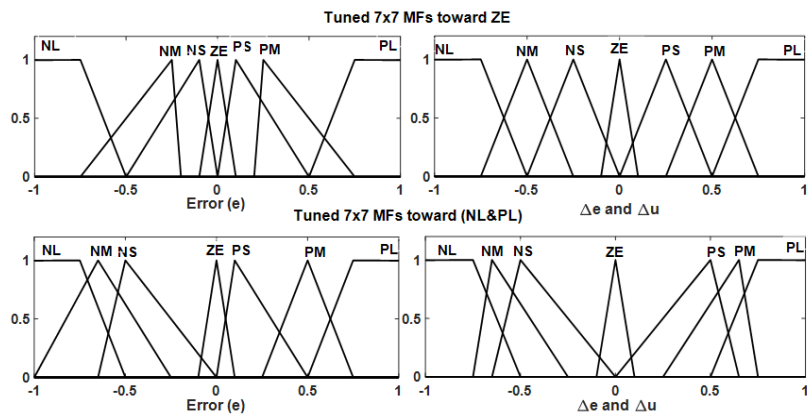

Figure 7. Tuned 7x7 MFs toward, ZE and (PL, NL) for error, change of error and change of output fuzzy

5. RESULTS AND DISCUSSIONS

In order to validate the effectiveness and workability of the adjusted MFs, an induction motor drive based on indirect field-oriented control (IFOC) is considered to conduct simulation analyses. An IM drive system is designed based on 2hp IM (parameters Table 4) in MATLAB/Simulink with FLC speed control using fuzzy logic toolbox. Performance analysis is conducted considering three different types of MFs (3x3, 5x5, and 7x7) and comparing them with proposed tuned MFs. Similar machine and simulation parameters are considered for both original and tuned MFs in order to make a fair comparison. The performance comparisons are done in terms of speed, current, and torque responses. For all the waveforms, a step of forward speed (1400rpm) is applied at (0.5s) and rated torque (10 Nm) is applied at (1.5s), then reverse speed (-1400rpm) is applied at (3s). The proposed tuned MFs show improved dynamic performance compared to the original MFs in terms of transient response, overshoot, and steady-state response.

Considering 3x3 MFs, the speed performance comparison of original MFs (FLC-9), Tuned MFs toward ZE (FLC-9-MF1), and tuned MFs toward, NL for error, NL, and PS for change of error and change of output (FLC-9-MF2) are shown in Figure 8 (a). As can be seen from the speed response, FLC-9-MF1 shows a faster response with almost zero overshoot during forward and reverse speed operations. However, FLC-9-MF2 shows a faster response with little overshoot during forward speed operation but records slow response during reverse (negative) speed operations. This because MF2 is tuned toward the NL side which makes the speed controller more sensitive to negative speed variations. To reduce the effects of high sensitivity toward negative speed variations, only MFs for error shifted toward the NL side, while for change of error and change of output MFs were tuned toward NL and PL side accordingly. In addition, both FLC-9-MF1 and FLC-9-MF2 have shown superior performance over the original MFs (FLC-9) during forward speed operations and during load disturbance. Apart from this, the stator phase a current and electromagnetic torque responses are shown in Figures 8 (b) and (c). Both tuned MFs showed good performance over the original MFs.

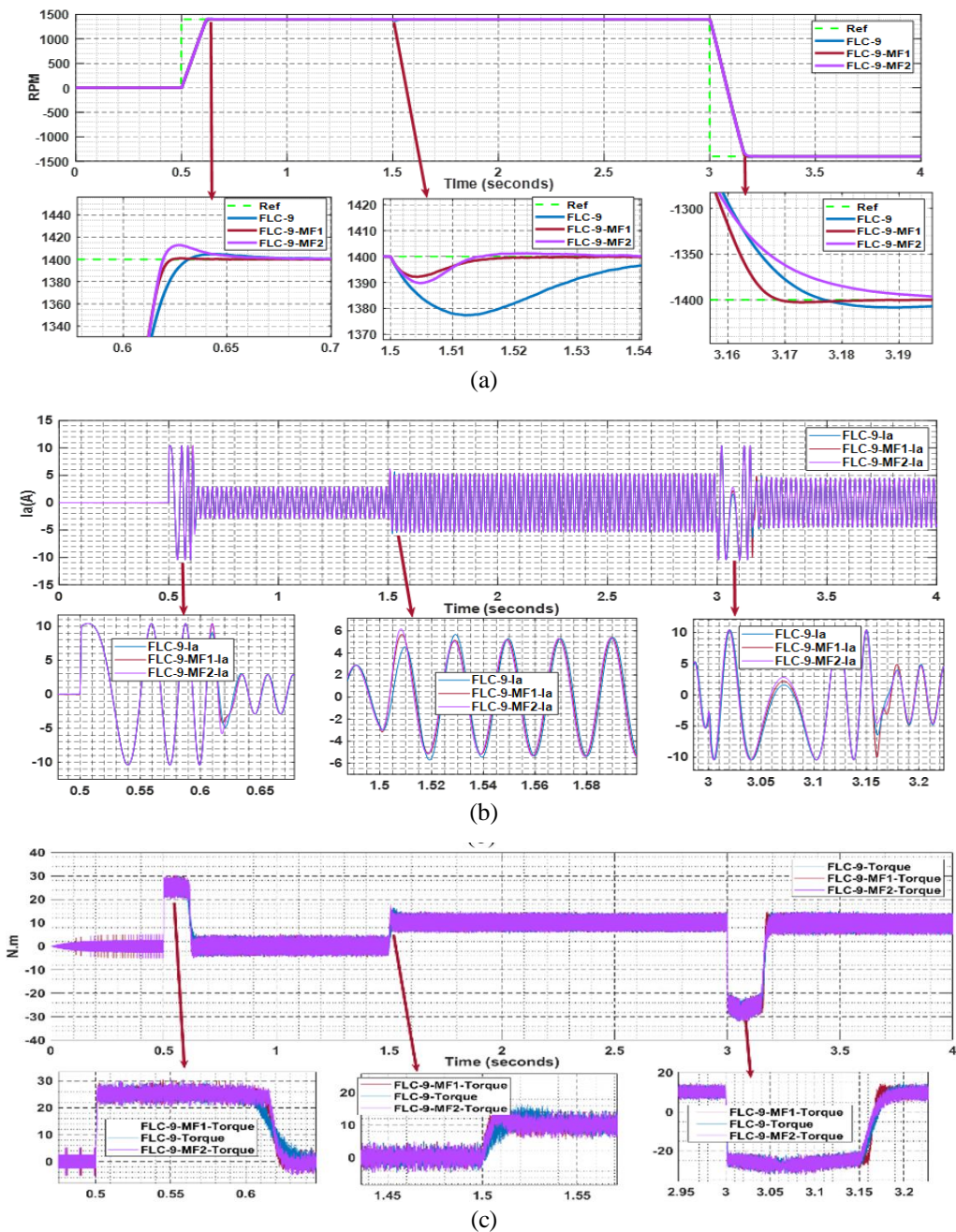

Figure 8. These figures are: (a) speed performance, (b) stator phase A current, and (c) torque response of original and tuned 3x3 MFs

Table 4. Induction motor parameters

Parameter	Value	Parameter	Value
Rated Voltage (V_s)	380 Vac	Stator Resistance (R_s)	3.45 Ω
Poles (P)	4	Rotor Resistance (R_r)	3.6141 Ω
Fundamental Frequency (F_s)	50Hz	Stator Inductance (L_s)	0.3246 H
Rated Speed (ω_s)	1430 rpm	Rotor Inductance (L_r)	0.3252 H
Maximum speed (ω_{max})	1500 rpm	Magnetizing Inductance (L_m)	0.3117 H
Rated current (i_s) / (i_{FL})	4.62 A / 6.4A	Inertia (J)	0.02 kgm^2
Rated Torque (T_e)	10 N.m	Viscous Friction (B)	0.001Nm/(rad/s)

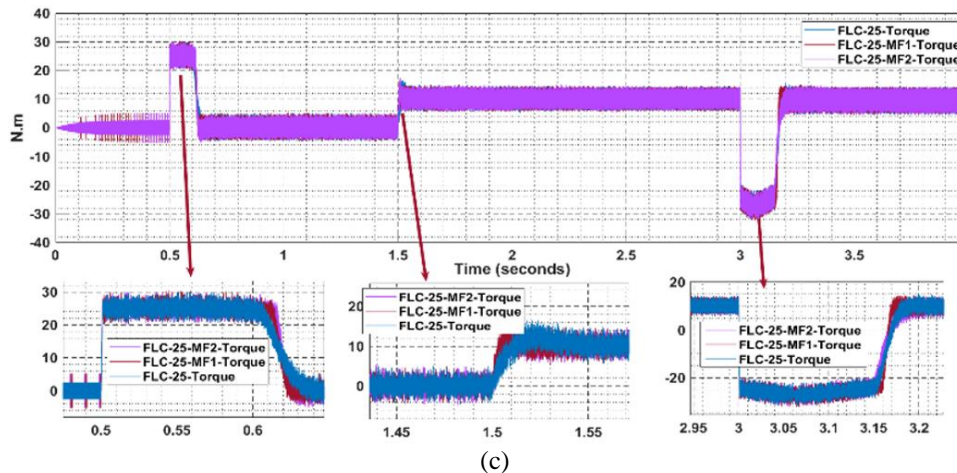
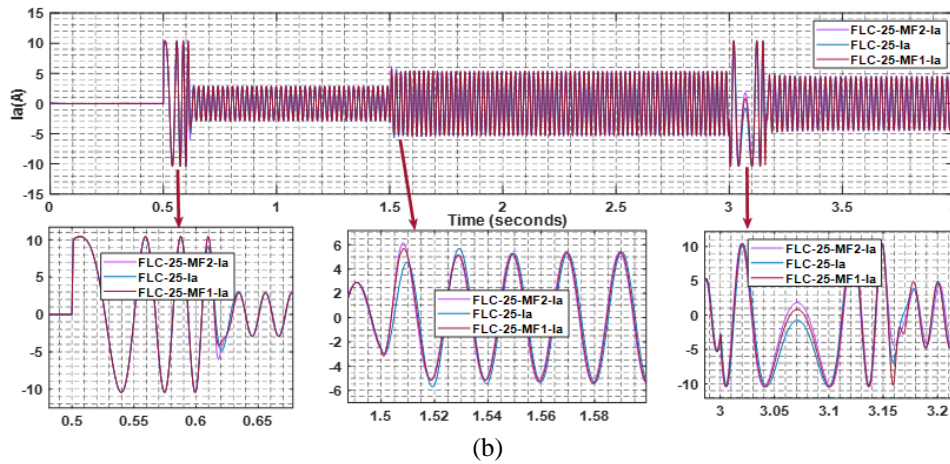
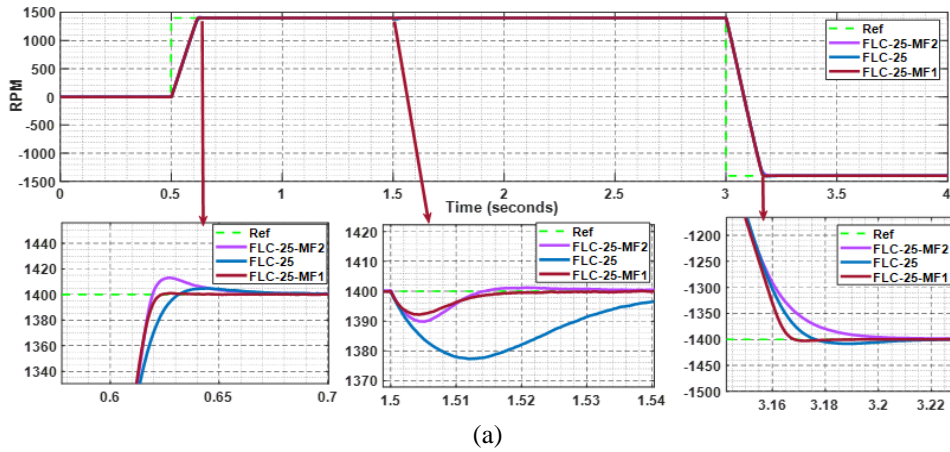

Figure 9. These figures are (a) speed performance, (b) stator phase A current, (c) torque response of original and tuned 3x3 MFs

In addition, the original and tuned MFs 5x5 showed similar performance as MFs 3x3 in which the tuned MFs produced good responses compared to original MFs. Figure 9 (a) shows the speed performance comparison of original and tuned MFs 5x5, while Figures 9 (b) and 9 (c) present the performance comparison of the stator phase (A) stator current and electromagnetic torque responses. As for 7x7 MFs, the tuned MFs showed improved performance over the original MFs in terms of fast dynamic response, stable steady-state response, and good load disturbance rejection. The speed performance comparison of original and tuned 7x7 MFs is presented in Figure 10 (a), while the stator current and torque response are shown in Figures 10 (b) and 10 (c).

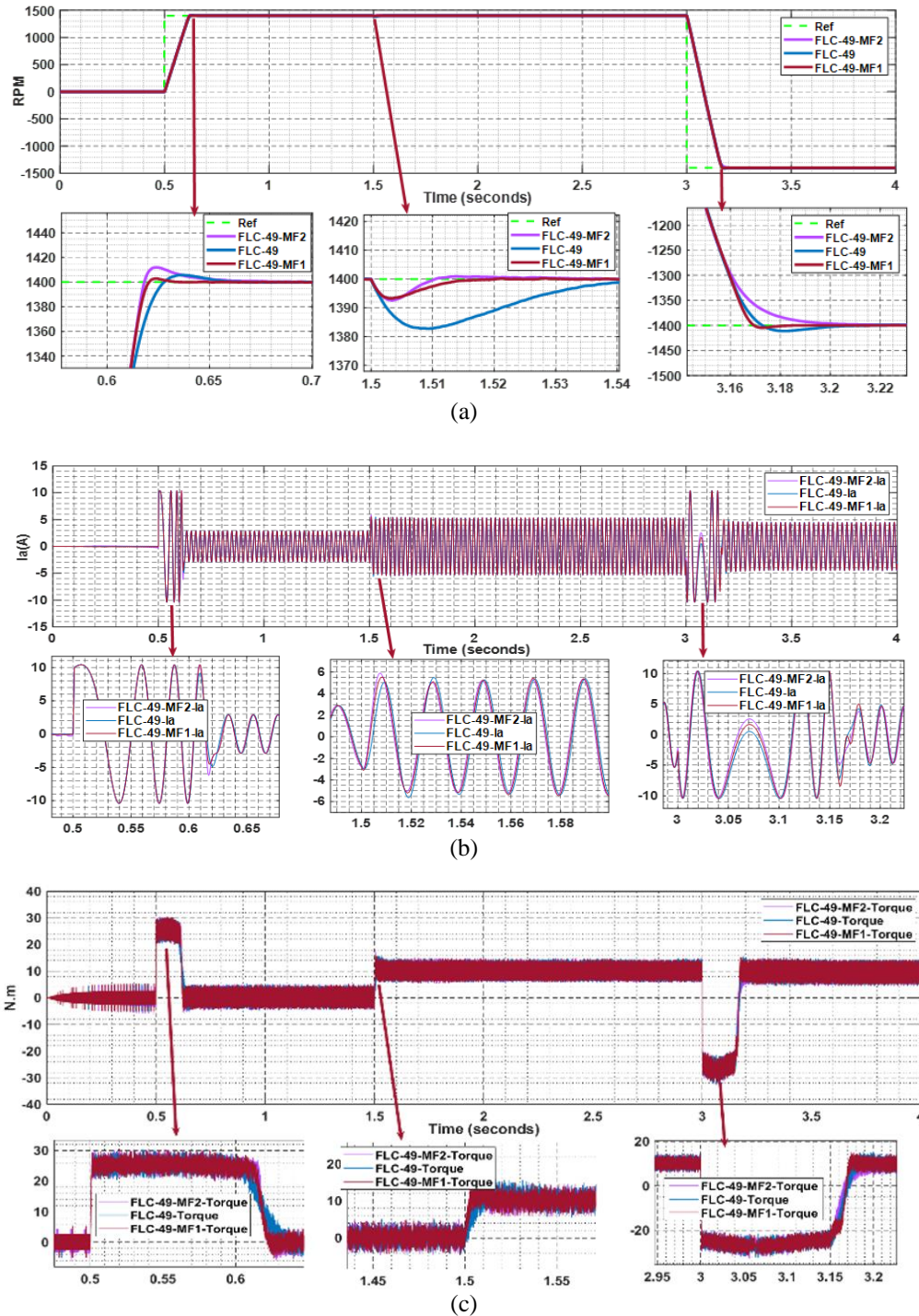

Figure 10. These figures are (a) speed performance, (b) stator phase A current, (c) torque response of original and tuned 3x3 MFs

In order to emphasize the superiority of tuned MFs over original MFs for IM drives, numerical comparisons between them are conducted in terms of rise time (T_r), settling time (T_s), overshoot (OS) and torque ripples. The numerical analyses of original MFs and tuned MFs are shown in Table 5 for 3x3 MFs, 5x5 MFs and 7x7 MFs. Based on the obtained numerical results of all properties, it is observed that, tuned MFs have improved the performance for all three MFs sizes (3x3), (5x5) and (7x7). The settling time (T_s) has improved with tuned MFs compared to the original MFs with 5% for 3x3 MFs, 3.48% for 5x5 MFs and 3.68% for 7x7 MFs. Besides, the overshoot (OS) has improved with 80.6% for 3x3 MFs, 78.52% for 5x5 MFs and 50% for 7x7 MFs. The torque ripples have improved with around 20% for all three MFs types. Original and tuned 7x7 MFs have bigger overshoot but smaller settling and rise time than 3x3 and 5x5 MFs, this because 7x7 MFs cover bigger error range and to reduce the overshoot, MFs of Δe and Δu have to be tuned more toward zero, but this will increase the settling time, thus must maintain balance between overshoot and settling time, where smaller settling time of (0.1152s) was obtained with minimum overshoot of 0.2063% of the tuned 7x7 MFs. In summary, it is proven that, tuning the MFs by effectively changing their distributions enhanced the performance of IM drive during the dynamic and steady-state operations.

Table 5. Numerical comparison of tuned and original MFs

Property Method	(T_s) seconds	(T_r) seconds	OS (%)	T-ripple
3x3 MFs	0.1243	0.0940	0.3469	2.7493
Tuned 3x3 MFs	0.1181	0.0936	0.0673	2.1746
5x5 MFs	0.1203	0.0940	0.3469	2.6203
Tuned 5x5 MFs	0.1161	0.0931	0.0745	2.1398
7x7 MFs	0.1196	0.0935	0.4125	2.5351
Tuned 7x7 MFs	0.1152	0.0921	0.2063	2.1138

6. CONCLUSION

Induction motors have various range of applications and their control systems are getting great attention from researchers and industries, due to their simple and rugged construction and less maintenance. A motor control system implies controlling the speed, torque, current, and/or flux of the motor. Speed control is normally achieved with a conventional controller like PI controller. But, for more adaptive control, fuzzy logic controller (FLC) is used that can handle non-linearity, parameters change, and speed variations. FLC comprises scaling factors, membership functions (MFs), and rule-base. Fuzzy MFs can have different shapes and sizes depending on the system requirements. Also, the widths and peak positions of MFs can be distributed symmetrically or asymmetrically. In this study, asymmetrical distribution of MFs widths and peak positions is considered based on three different MFs sizes (3x3, 5x5, and 7x7). For each MF size, two different distributions are considered as MFs distributed toward the origin (zero), MFs distributed toward the negative and the positive sides. These MFs distributions (tuned MFs) for each MF size 3x3, 5x5, and 7x7 are simulated based on IM drive system and compared with original MFs. Performance comparisons between original MFs and tuned MFs in terms of dynamic and steady-state characteristics. Based on, the simulation and numerical results, tuned MFs have improved the dynamic response compared to the original MFs with 5%, 3.48% and 3.68% settling time improvement and 80.6%, 78.52% and 50% overshoot improvement for 3x3, 5x5 and 7x7 MFs respectively. Also, the steady state response with tuned MFs has improved compared to the original MFs, where around 20% torque ripple improvement was recorded for all three MFs types.

ACKNOWLEDGEMENTS

The authors would like to gratefully acknowledge the funding support provided by Universiti Teknikal Malaysia Melaka (UTeM) and the Ministry of Education Malaysia under the research grant No: FRGS/1/2020/TK0/UTEM/02/45.

REFERENCES

- [1] R. Parekh, "AC induction motor fundamentals," *Microchip Technology Inc*, no. DS00887A, pp. 1-24, 2003.
- [2] T. Sadeq, C. K. Wai, E. Morris, Q. A. Tarboosh, and O. Aydogdu, "Optimal Control Strategy to Maximize the Performance of Hybrid Energy Storage System for Electric Vehicle Considering Topography Information," *IEEE Access*, vol. 8, pp. 216994-217007, 2020, doi: 10.1109/access.2020.3040869.
- [3] V. Kumar, S. S. Kumar, and K. Reddy, "Implementation of Scalar Control Technique in SVPWM Switched Three-Level Inverter Fed Induction Motor Using DSP Controller," *International Journal of Power Electronics and Drive Systems*, vol. 1, no. 2, p. 83, 2011, doi: 10.11591/ijpeds.v1i2.98.

- [4] T. H. dos Santos, A. Goedtel, S. A. O. da Silva, and M. Suetake, "Scalar control of an induction motor using a neural sensorless technique," *Electric power systems research*, vol. 108, pp. 322-330, 2014, doi: 10.1016/j.epr.2013.11.020.
- [5] J. Papazian, J. Rognon, D. Roje, and P. Delbosc, "From scalar control to space vector control: Functions and limitations of the different elements," in *IAS'95. Conference Record of the 1995 IEEE Industry Applications Conference Thirtieth IAS Annual Meeting*, 1995, vol. 3: IEEE, pp. 1944-1950.
- [6] S. S. Biswas, "Basics of Vector Control of Asynchronous Induction Motor and Introduction to Fuzzy Controller," in *Artificial Intelligent Techniques for Electric and Hybrid Electric Vehicles*, 2020, pp. 241-258, doi: 10.1002/9781119682035.ch14.
- [7] J. Bocker and S. Mathapati, "State of the art of induction motor control," in *2007 IEEE International Electric Machines & Drives Conference*, 2007, vol. 2: IEEE, pp. 1459-1464, doi: 10.1109/IEMDC.2007.383643.
- [8] R.-J. Wai and K.-M. Lin, "Robust decoupled control of direct field-oriented induction motor drive," *IEEE Transactions on Industrial Electronics*, vol. 52, no. 3, pp. 837-854, 2005, doi: 10.1109/TIE.2005.847585.
- [9] Y. Zhang, J. Zhu, Z. Zhao, W. Xu, and D. G. Dorrell, "An improved direct torque control for three-level inverter-fed induction motor sensorless drive," *IEEE transactions on power electronics*, vol. 27, no. 3, pp. 1502-1513, , 2010, doi: 10.1109/TPEL.2010.2043543.
- [10] J.-D. Tan, S.-P. Koh, S.-K. Tiong, K. Ali, and A. Abdalla, "Fuzzy Logic Enhanced Direct Torque Control with Space Vector Modulation," *Indonesian Journal of Electrical Engineering and Computer Science*, vol. 11, no. 2, 2018, doi: 10.11591/ijeecs.v11.i2.pp704-710.
- [11] R. M. Kennel, M. Kazmierkowski, J. Rodriguez, and P. Cortes, "Predictive control in power electronics and drives," in *2008 IEEE International Symposium on Industrial Electronics*, 30 June-2 July 2008 2008, pp. 1-90, doi: 10.1109/ISIE.2008.4677323.
- [12] Y. Zhang and H. Yang, "Model Predictive Torque Control of Induction Motor Drives With Optimal Duty Cycle Control," *IEEE Transactions on Power Electronics*, vol. 29, no. 12, pp. 6593-6603, 2014, doi: 10.1109/TPEL.2014.2302838.
- [13] N. Farah, Md H. N. Talib, Z. Ibrahim, Q. Abdullah, and Ö. Aydoğdu, "Analysis and investigation of different advanced control strategies for high-performance induction motor drives," *TELKOMNIKA Telecommunication Computing Electronics and Control*, vol. 18, no. 6, pp. 3303-3314, 2020, doi: 10.12928/telkomnika.v18i6.15342
- [14] M. Chebre, A. Meroufel, and Y. Bendaha, "Speed control of induction motor using genetic algorithm-based PI controller," *Acta Polytechnica Hungarica*, vol. 8, no. 6, pp. 141-153, 2011.
- [15] H.-B. Shin, "New antiwindup PI controller for variable-speed motor drives," *IEEE Transactions on industrial electronics*, vol. 45, no. 3, pp. 445-450, 1998, doi: 10.1109/41.679002.
- [16] R. Arulmozhiyal and K. Baskaran, "Implementation of a fuzzy PI controller for speed control of induction motors using FPGA," *Journal of Power Electronics*, vol. 10, no. 1, pp. 65-71, 2010, doi: 10.6113/JPE.2010.10.1.065.
- [17] Z. Ibrahim and E. Levi, "A comparative analysis of fuzzy logic and PI speed control in high-performance AC drives using experimental approach," *IEEE Transactions on Industry Applications*, vol. 38, no. 5, pp. 1210-1218, 2002, doi: 10.1109/TIA.2002.802993.
- [18] Y. Tang and L. Xu, "Fuzzy Logic Application for Intelligent Control of a Variable Speed Drive," *IEEE Transactions on Energy Conversion*, vol. 9, no. 4, pp. 679-685, 1994, doi: 10.1109/60.368341.
- [19] Z. Mekrini and B. Seddik, "Fuzzy logic application for intelligent control of an asynchronous machine," *Indonesian Journal of Electrical Engineering and Computer Science*, vol. 7, no. 1, pp. 61-70, 2017, doi: 10.11591/ijeecs.v7.i1.pp61-70.
- [20] F. A. Lootsma, *Fuzzy logic for planning and decision making*. Springer Science & Business Media, 2013.
- [21] M. N. Uddin, T. S. Radwan, and M. A. Rahman, "Performances of fuzzy-logic-based indirect vector control for induction motor drive," *IEEE Transactions on Industry applications*, vol. 38, no. 5, pp. 1219-1225, 2002, doi: 10.1109/TIA.2002.802990.
- [22] N. Farah *et al.*, "A Novel Self-Tuning Fuzzy Logic Controller Based Induction Motor Drive System: An Experimental Approach," *IEEE Access*, vol. 7, pp. 68172-68184, 2019, doi: 10.1109/ACCESS.2019.2916087.
- [23] N. Farah, M. Talib, Z. Ibrahim, J. Lazi, and M. Azri, "Self-tuning Fuzzy Logic Controller Based on Takagi-Sugeno Applied to Induction Motor Drives," *International Journal of Power Electronics and Drive Systems*, vol. 9, no. 4, p. 1967, 2018, doi: 10.11591/ijpeds.v9n4.pp1967-1975.
- [24] K. Zeb, Z. Ali, K. Saleem, W. Uddin, M. A. Javed, and N. Christofides, "Indirect field-oriented control of induction motor drive based on adaptive fuzzy logic controller," *Electrical Engineering*, vol. 99, no. 3, pp. 803-815, 2017, doi: 10.1007/s00202-016-0447-5.
- [25] M. A. Mannan, "A Fuzzy Logic Controller with Tuning Output Scaling Factor for Induction Motor Control Taking Core Loss into Account," *International Journal of Intelligent Systems and Applications in Engineering*, vol. 2, no. 3, pp. 46-50, 2014, doi: 10.18201/ijisae.25215.
- [26] M. Ismail, M. Talib, Z. Ibrahim, J. M. Lazi, and Z. Rasin, "Experimental simplified rule of self tuning fuzzy logic-model reference adaptive speed controller for induction motor drive," *Indonesian Journal of Electrical Engineering and Computer Science*, vol. 20, no. 3, pp. 1653-1664, 2020, doi: 10.11591/ijeecs.v20.i3.pp1653-1664.
- [27] N. Farah, M. Talib, Z. Ibrahim, M. Azri, and Z. Rasin, "Self-tuned output scaling factor of fuzzy logic speed control of induction motor drive," in *2017 7th IEEE International Conference on System Engineering and Technology (ICSET)*, 2017: IEEE, pp. 134-139, doi: 10.1109/ICSEngT.2017.8123434.
- [28] M. Talib, Z. Ibrahim, Z. Rasin, J. M. Lazi, and S. M. Isa, "Simplified self-tuning Fuzzy Logic Speed controller for induction motor drive," in *2016 IEEE International Conference on Power and Energy (PECon)*, 2016: IEEE, pp. 188-193, doi: 10.1109/PECON.2016.7951557.

- [29] Q. A. Tarbushomer Aydogdu, N. Farah, A. Salh, and N. Cankaya, "Review and investigation of simplified rules fuzzy logic speed controller of high performance induction motor drives," *IEEE Access*, vol. 8, pp. 49377-49394, 2020, doi: 10.1109/ACCESS.2020.2977115.
- [30] Z. Ibrahim, S. M. Isa, J. M. Lazi, and M. H. N. Talib, "Simplified fuzzy logic speed controller for vector controlled permanent magnet synchronous motor drives," *International Review of Electrical Engineering*, vol. 8, no. 1, pp. 104-113, 2013.
- [31] B. Kumar, Y. Chauhan, and V. Shrivastava, "Performance Evaluation of Reduced Rule Base Fuzzy Logic Controller for Indirect Vector Controlled Induction Motor Drive," in *Proc. 4th International Conference on Computer Simulation and Modeling*, 2012, pp. 81-86.
- [32] J. Zhao and B. K. Bose, "Evaluation of membership functions for fuzzy logic controlled induction motor drive," in *IEEE 2002 28th Annual Conference of the Industrial Electronics Society. IECON 02*, 2002, vol. 1: IEEE, pp. 229-234, doi: 10.1109/IECON.2002.1187512.
- [33] F. Betin, D. Pinchon, and G.-A. Capolino, "Fuzzy logic applied to speed control of a stepping motor drive," *IEEE Transactions on Industrial Electronics*, vol. 47, no. 3, pp. 610-622, 2000, doi: 10.1109/41.847902.
- [34] J. Zhao and B. K. Bose, "Membership function distribution effect on fuzzy logic controlled induction motor drive," in *IECON'03. 29th Annual Conference of the IEEE Industrial Electronics Society (IEEE Cat. No. 03CH37468)*, 2003, vol. 1: IEEE, pp. 214-219, doi: 10.1109/IECON.2003.1279982.
- [35] J. G. Monicka, N. G. Sekhar, and K. R. Kumar, "Performance evaluation of membership functions on fuzzy logic controlled ac voltage controller for speed control of induction motor drive," *International Journal of Computer Applications*, vol. 13, no. 5, pp. 8-12, 2011, doi: 10.5120/1778-2451.
- [36] Z. Salleh, M. Sulaiman, and R. Omar, "Tuning fuzzy membership functions to improve performance of vector control induction motor drives," *Journal of Telecommunication, Electronic and Computer Engineering (JTEC)*, vol. 8, no. 2, pp. 1-4, 2016.
- [37] G. Abad, J. Lopez, M. Rodriguez, L. Marroyo, and G. Iwanski, *Doubly fed induction machine: modeling and control for wind energy generation*. John Wiley & Sons, 2011, doi: 10.1002/9781118104965.
- [38] A. P. Mark, R. Vairamani, and G. C. R. Irudayaraj, "Mathematical modeling and analysis of different vector controlled CSI fed 3-phase induction motor drive," *Journal of Applied Mathematics*, vol. 2014, 2014, doi: 10.1155/2014/623982.
- [39] M. Masiala, B. Vafakhah, J. Salmon, and A. M. Knight, "Fuzzy self-tuning speed control of an indirect field-oriented control induction motor drive," *IEEE Transactions on Industry Applications*, vol. 44, no. 6, pp. 1732-1740, 2008, doi: 10.1109/TIA.2008.2006342.
- [40] W. J. Kickert and E. H. Mamdani, "Analysis of a fuzzy logic controller," in *Readings in Fuzzy Sets for Intelligent Systems*: Elsevier, 1993, pp. 290-297.
- [41] Y. Bai and D. Wang, "Fundamentals of fuzzy logic control-fuzzy sets, fuzzy rules and defuzzifications," in *Advanced Fuzzy Logic Technologies in Industrial Applications*: Springer, pp. 17-36, 2006, doi: 10.1007/978-1-84628-469-4_2.
- [42] M. Talib *et al.*, "An improved simplified rules Fuzzy Logic Speed Controller method applied for induction motor drive," *ISA Transactions*, 2020, doi: 10.1016/j.isatra.2020.05.040.
- [43] R. K. Mudi and N. R. Pal, "A robust self-tuning scheme for PI-and PD-type fuzzy controllers," *IEEE Transactions on fuzzy systems*, vol. 7, no. 1, pp. 2-16, 1999, doi: 10.1109/91.746295.
- [44] A. Pal and R. Mudi, "Self-tuning fuzzy PI controller and its application to HVAC systems," *International journal of computational cognition*, vol. 6, no. 1, pp. 25-30, 2008.
- [45] B. Kumar, Y. K. Chauhan, and V. Shrivastava, "Efficacy of different rule based fuzzy logic controllers for induction motor drive," *International Journal of Machine Learning and Computing*, vol. 2, no. 2, p. 131, 2012, doi: 10.7763/IJMLC.2012.V2.101.
- [46] N. Farah, M. Talib, Z. Ibrahim, Z. Rasin, and Z. Rizman, "Experimental investigation of different rules size of fuzzy logic controller for vector control of induction motor drives," *Journal of Fundamental and Applied Sciences*, vol. 10, no. 6S, pp. 1696-1717, 2018.
- [47] L. Zhen and L. Xu, "Fuzzy learning enhanced speed control of an indirect field-oriented induction machine drive," *IEEE Transactions on Control Systems Technology*, vol. 8, no. 2, pp. 270-278, 2000, doi: 10.1109/87.826798.
- [48] O. A. M. Ali, A. Y. Ali, and B. S. Sumait, "Comparison between the effects of different types of membership functions on fuzzy logic controller performance," *International Journal of Emerging Engineering Research and Technology*, vol. 3, no. 3, pp. 76-83, 2015.