

# Explorative Studies of an Innovative Superconducting Gantry

M. G. Pullia<sup>1</sup>, M. Donetti, E. Felcini, G. Frisella, A. Mereghetti, A. Mirandola, A. Pella, S. Savazzi, CNAO Foundation, Pavia, Italy  
 L. Dassa, M. Karppinen, D. Perini, D. Tommasini, M. Vretenar, CERN, Geneva, Switzerland  
 C. Kurfürst, M. T. F. Pivi, M. Stock, EBG MedAustron, Wr. Neustadt, Austria  
 E. De Matteis, S. Mariotto<sup>2</sup>, M. Prioli, L. Rossi, INFN–Milano, LASA Laboratory, Segrate, Italy  
 L. Sabbatini, A. Vannozzi, INFN–LNF, Frascati, Italy  
 L. Piacentini, A. Ratkus, T. Torims, J. Vilcans, Riga Technical University, Riga, Latvia  
 E. Benedetto, SEEIIST, Geneva, Switzerland

<sup>1</sup>marco.pullia@cnao.it, <sup>2</sup>also at University of Milan, Milan, Italy

## Abstract

The Heavy Ion Therapy Research Integration plus (HITRI<sup>plus</sup>) is an European project that aims to integrate and propel research and technologies related to cancer treatment with heavy ion beams. Among the ambitious goals of the project, a specific work package includes the design of a gantry for carbon ions, based on superconducting magnets. The first milestone to achieve is the choice of the fundamental gantry parameters, namely the beam optics layout, the superconducting magnet technology, and the main user requirements. Starting from a reference 3 T design, the collaboration widely explored dozens of possible gantry configurations at 4 T, aiming to find the best compromise in terms of footprint, capital cost, and required R&D. We present here a summary of these configurations, underlying the initial correlation between the beam optics, the mechanics and the main superconducting dipoles design: the bending field (up to 4 T), combined function features (integrated quadrupoles), magnet aperture (up to 90 mm), and angular length (30° – 45°). The resulting main parameters are then listed, compared, and used to drive the choice of the best gantry layout to be developed in HITRI<sup>plus</sup>.

## Clinical Requirements

Extensively discussed with medical physicists and doctors at CNAO and MedAustron:

- the beam with the largest magnetic rigidity is  $^{12}\text{C}^{6+}$  at 430 MeV per nucleon kinetic energy, corresponding to 6.62 Tm and 31 cm of range in water;
- the scanned area shall be as large as possible, indicatively 350 mm × 350 mm, at least 200 mm × 300 mm. The minimum scanning speed shall be 20 m/s;
- the minimum beam sizes at the isocenter shall be 8 mm and 12 mm (FWHM) at the minimum energy;
- a source-to-axis distance (SAD) of at least 2 m – 2.5 m;
- possibly 360° rotation, minimum 220°;
- volumetric imaging at the isocenter.

## Assumptions

- scanning magnets located downstream of the last bending section, to relax constraints on the aperture of the SC magnets;
- 4 T SC dipoles, corresponding to a bending radius of 1.65 m for  $^{12}\text{C}^{6+}$  at 430 MeV per nucleon. Depending on the optics, a quadrupole field may be necessary: this would be obtained by an asymmetric arrangement of the coils. The magnet aperture should be 70 mm – 90 mm. The maximum ramp rate  $\dot{B}$  should be 0.4 T/s;
- achromatic optics solutions at the isocentre, implying that the spot size and position at the isocentre is independent of the beam momentum distribution;
- beam dimensions at the isocentre independent of the gantry angle of rotation. This implies that either a “rotator” is installed upstream of the gantry or that the incoming beam is round.

## Costs

- total cost of gantry estimated, based on the experience of the teams responsible for the development of the different aspects of the gantry design;
- total cost estimation considers: magnets, power supplies, ancillary systems, rotation mechanics and building (only gantry room);
- for the same range of rotation angle, the cost of the two selected layouts differ by not more than 10%; moreover, the difference in total cost between the two layouts in the 220° and 360° configurations is about 15%.

## Layout Exploration

Key gantry parameters among different layouts (numbered from 1 to 10) and optics. The required magnet aperture when matching with varying MF for a given value of input  $\beta$  function or when varying the input  $\beta$  function for a given value of MF are indicated. The results in the table consider a parallel-to-point matching method but for layouts 3, 4, 7 and 10, for which point-to-point matching is performed.

| Layout                              | 1               | 2                | 3                  | 4                | 5               | 6                | 7                | 8                | 9                | 10               |
|-------------------------------------|-----------------|------------------|--------------------|------------------|-----------------|------------------|------------------|------------------|------------------|------------------|
| <b>Geometry Parameters</b>          |                 |                  |                    |                  |                 |                  |                  |                  |                  |                  |
| Length [m]                          | 12.9            | 14.05            | 11.7               | 13.2             | 10.4            | 14.2             | 14.2             | 13.5             | 14.05            | 14.2             |
| Radius [m]                          | 6.4             | 5.75             | 5.75               | 7.3              | 6               | 5.55             | 5.55             | 5.25             | 5.75             | 5.1              |
| After last bending [m]              | 4               | 3.5              | 3.5                | 4                | 3.6             | $\beta^a$        | $\beta^a$        | $\beta^a$        | 3.5              | $\beta^a$        |
| SC dipoles: N × angle               | 7 × 30°         | 4 × 45°          | 7 × 30°            | 9 × 30°          | 9 × 30°         | 4 × 45°          | 4 × 45°          | 4 × 45°          | 4 × 45°          | 4 × 45°          |
| SC dipole families                  | 3               | 1                | 3                  | 3                | 9               | 1                | 1                | 1                | 2                | 2                |
| Quadrupoles: NC/SC                  | 0/6             | 5/4              | 0/6                | 6/2              | 0/2             | 6/4              | 6/4              | 5/4              | 5/4              | 0/8              |
| <b>Aperture [mm]</b>                |                 |                  |                    |                  |                 |                  |                  |                  |                  |                  |
| var. MF, $\Delta p/p = 0.1\%$       | 90 <sup>b</sup> | 70               | 90 <sup>b</sup>    | 90               | 70 <sup>b</sup> | 70               | 90               | 70               | 93               | 90               |
| var. $\beta$ , $\Delta p/p = 0.1\%$ | 90              | 70               | 93                 | 90               | 70              | 70               | 90               | 70               | 96 <sup>c</sup>  | 90               |
| var. MF, $\Delta p/p = 1\%$         | 90 <sup>b</sup> | 163 <sup>c</sup> | 105 <sup>b,c</sup> | 174 <sup>c</sup> | 90 <sup>b</sup> | 156 <sup>c</sup> | 111 <sup>c</sup> | 162 <sup>c</sup> | 120 <sup>c</sup> | 165 <sup>c</sup> |
| var. $\beta$ , $\Delta p/p = 1\%$   | 90              | 168 <sup>c</sup> | 111 <sup>c</sup>   | 129 <sup>c</sup> | 93              | 168 <sup>c</sup> | 123 <sup>c</sup> | 165 <sup>c</sup> | 135 <sup>c</sup> | 165 <sup>c</sup> |

<sup>a</sup>Distance between the last bending section and the isocentre smaller than 3 m.

<sup>b</sup>Nested SC elements.

<sup>c</sup>Magnet aperture beyond the allowed range (i.e. 70 mm – 90 mm).

## Selected Layouts

**Layout 1** It allows transporting beams with a 1% beam momentum spread, in the scenario for which the input  $\beta$  functions are varied; SC dipoles of 30°.

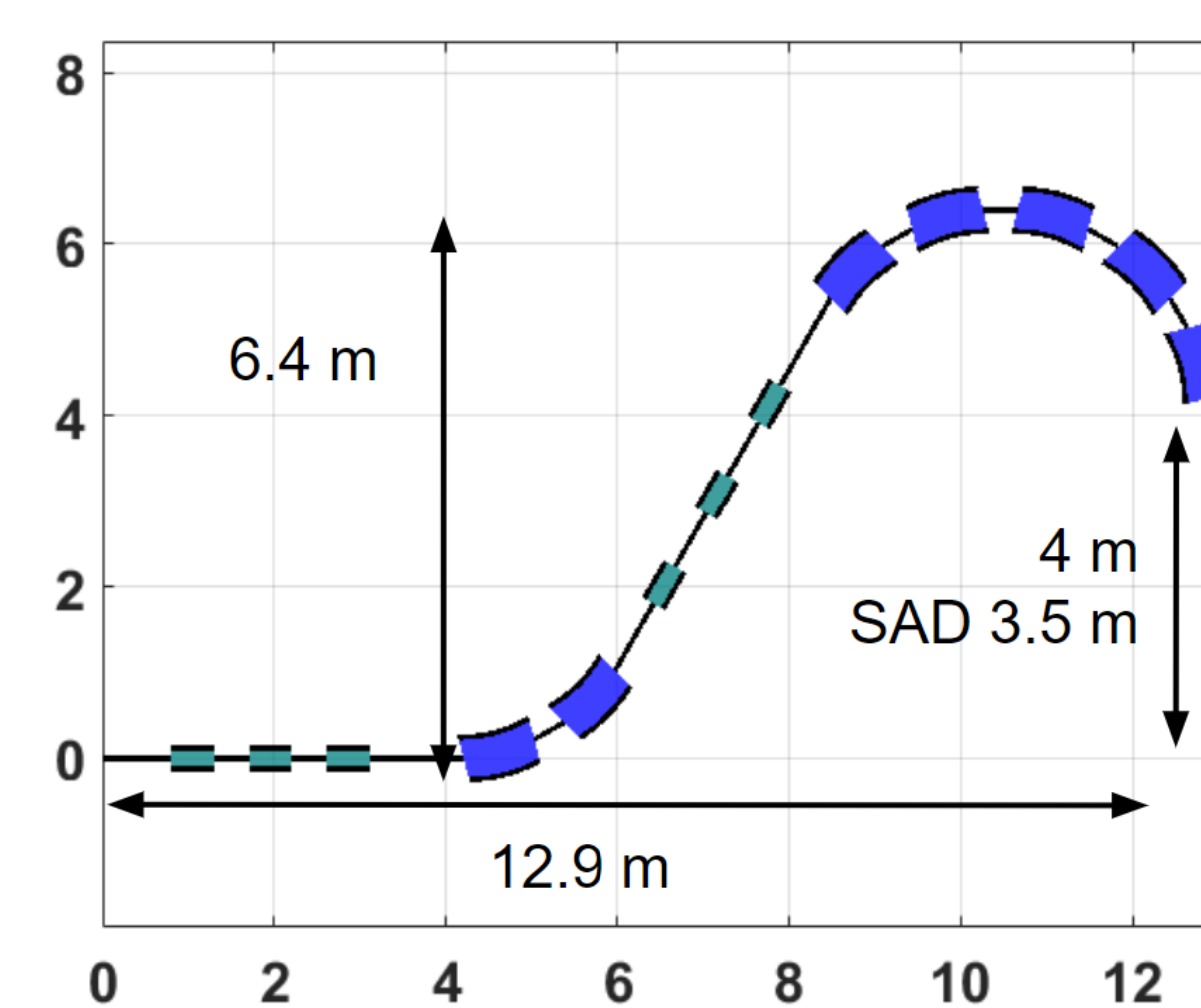

**Layout 2** It allows working with a beam momentum spread of 0.1%, in the scenario for which the MF is varied for the same  $\beta$  functions; SC dipoles of 45°.

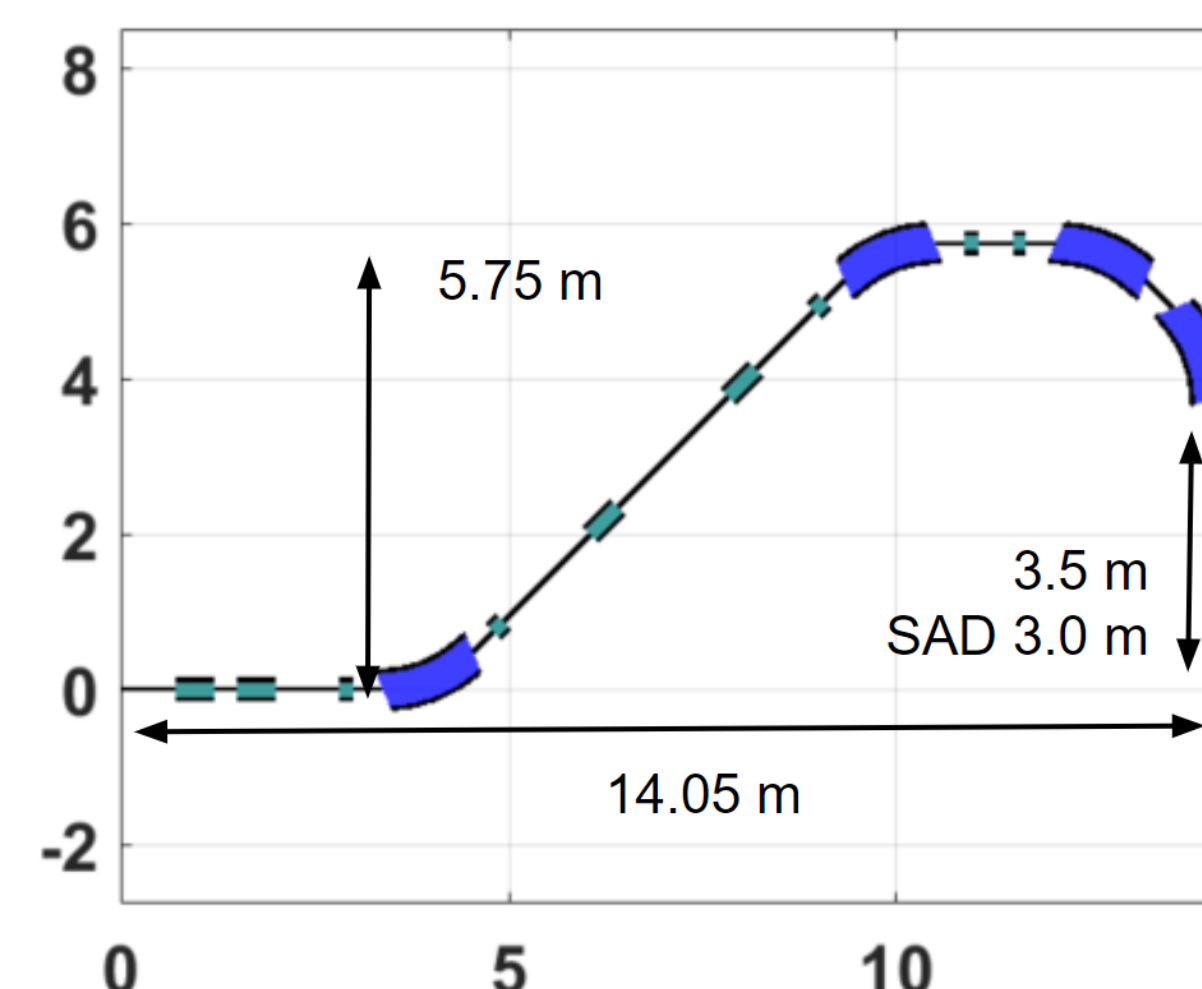

## Mechanical Layouts

**Balanced SIGRUM** Balanced structure with side supports; motor and gearbox mounted on the axis. Treatment angle range: ±110°; total rotating mass: 70 t.

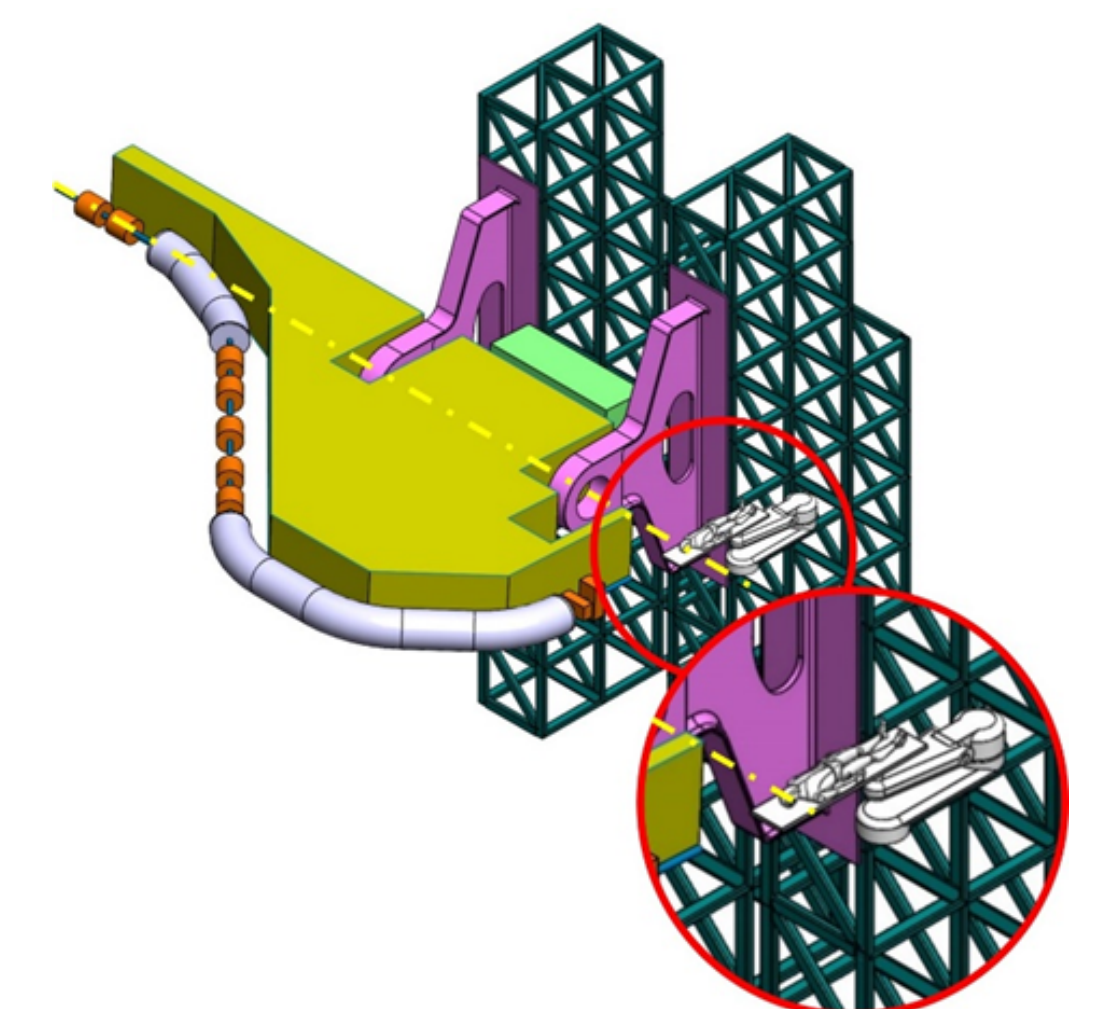

**Full Turn Gantry** Balanced structure with ground supports; motor drives off-axis friction rollers. Treatment angle range: ±180°; total rotating mass: 120 t.

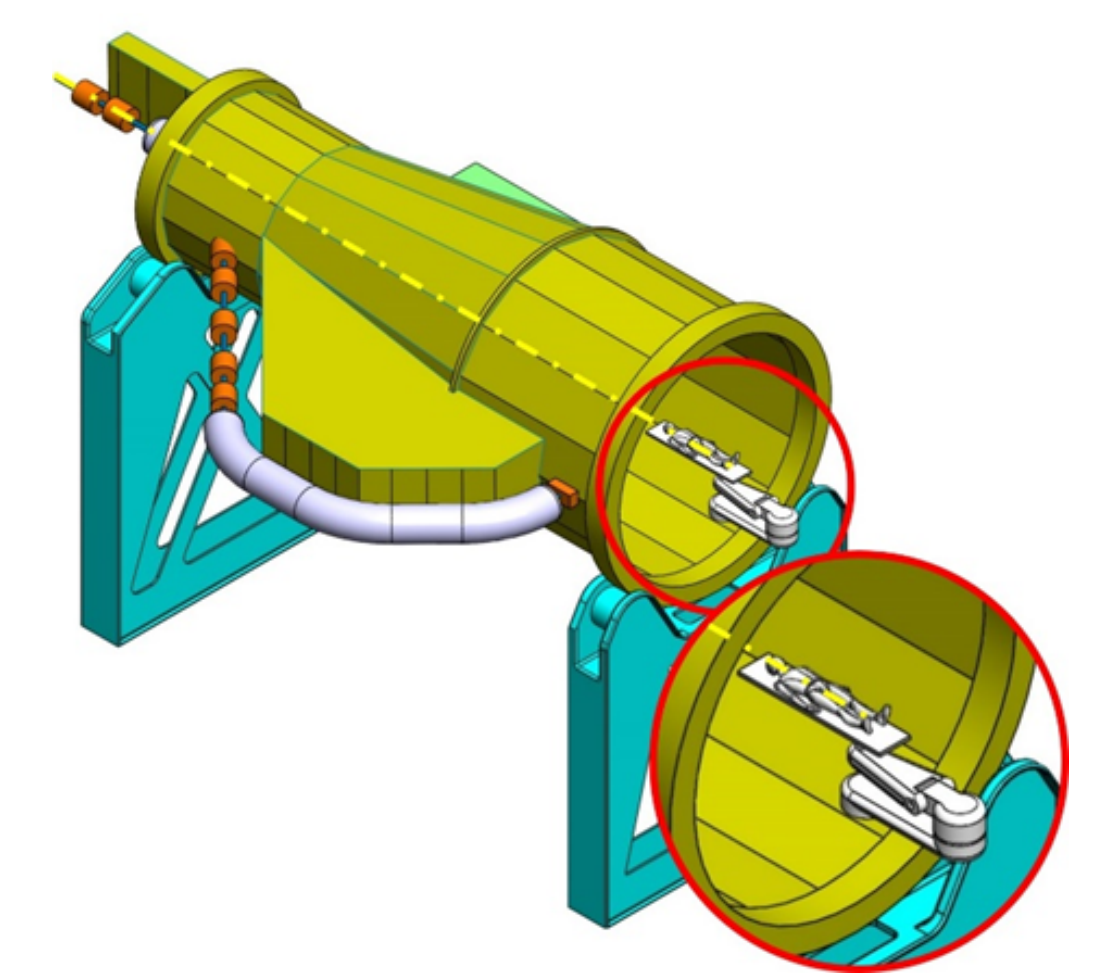

**HITRI**<sup>plus</sup>  
 Heavy Ion Therapy Research Integration



This project has received funding from the European Union's Horizon 2020 research and innovation programme under grant agreement No 101008548