



Smart attendance system using RFID and Wi-Fi module

Indrayudh Bandyopadhyay^{1, *}, Sayan Chakraborty², Arindam Pyne³

¹Dept. of Electrical Engineering, St. Thomas' College of Engg. & Tech., Kolkata, India.

²School of Illumination Science, Engineering and Design, Jadavpur University, Kolkata, West Bengal, India.

³Dept. of Power Engineering, Jadavpur University, Kolkata, West Bengal, India.

Received: 08 April 2022

Accepted: 25 April 2022

Published Online:

16 May 2022

© The Author(s) 2022

ABSTRACT

The combination of Electrical Engineering (EE) and Information Technology (IT) has played a significant role in developing several aspects in academic and professional sectors such as student or employee monitoring. It is a critical subject to track and to manage employee attendance in work places urging employees to attend on time to increase efficiency of work, so is at schools or colleges for students. Hence, an attendance system can be useful to reduce administrative complexity and cost. The conventional pen-paper based attendance system is not absolutely flawless. In this paper we have designed an attendance system using RFID and Wi-Fi Module. Radio Frequency Identification (RFID) is an extensive application to yield maximum advantage of this technology with minimal effort for management and attendance monitoring. But it is hard to keep track of every individual only through monitoring. At such times we need an online solution. We have used Node MCU for this purpose. It is a complete and self-contained Wi-Fi network solution that can carry software applications as a stand-alone device or connected with a microcontroller.

Keywords

Pen-paper based Attendance System, Radio Frequency Identification (RFID), MFRC522, Wi-Fi module, Node MCU, ESP8266

Heading Editor: Satheesh Kumar

Address Correspondence to E-mail: ayudh.indra@gmail.com

I. INTRODUCTION

Attendance monitoring is an indispensable part of any institute or office. Monitoring of attendance helps increasing quality outcome, be it an educational institute or be it an office. The pen-paper based manual attendance system had too many fallacies. Moreover, it had a possibility of manipulation of the original data. So, we have tried to make an automatic attendance system that would be to some extent free from some of the drawbacks of the pen-paper based attendance system.

The system works in two parts.

- 1) Attendance Marking.
- 2) Attendance Storing.

In writing [1], model structure of microcontroller based participation framework utilizing RFID and GSM has been exhibited. The RFID kit that has been used in this project, i.e. – MFRC522 module kit contains one RFID scanner and one RFID card or RFID tag. The card can be used as an employee ID card or student ID card [2]. The RFID scanner is placed at the main entrance. Whenever the person enters from the main entrance, he/she has to scan her card and the corresponding attendance with Entry time is marked. The same thing one has to do while leaving the premises to mark the Exit time. However, for student attendance system the later part may not be necessary. Now, the attendance storing process via Wi-Fi can be done in two ways.

- 1) Using Local Server and MFRC522 and ESP8266 connected in same Wi-Fi network.
- 2) Using a website which is accessible via Internet.

A database is created in both the cases which contain the employee/student details along with their corresponding RFID card address. Whenever a card is scanned the corresponding attendance is marked and stored in the database.

II. LITERATURE SURVEY

Now in the era of digital and smart technologies manual operation of attendance system is gradually becoming obsolete. The traditional pen-paper based attendance system is being digitalized and automation of the system is being incorporated.

Several research works have been done and many types of system have been proposed. MD Asdaque Hussain, Komirisetty Venkata Naga Krishna, Ramanulla Lakshmi Chandana, Velivela Krishna Chaitanya described a system where attendance is tracked using RFID and GSM. An SMS alert is sent to the students' parent's mobile whose attendance is missing and is supposed to be present. T.S. Lim, S.C. Sim, M.M. Mansor proposed an automatic attendance system which used RFID. This system is connected to computer by RS232 or Universal Serial Bus (USB) and store the attendance taken inside database. An alternative way of viewing the recorded attendance is by using HyperTerminal software. Another attendance system was proposed by Rasika Naik, Maumita Mal, Shweta Koli, Aakash Karnani, Bhavesh Chetwani. In order to make attendance system automatic, remove chance of proxy attendance they have used a terminal fingerprint acquisition module and attendance management module in computer which is configured with the Zigbee module as the transmitter and receiver node. This system has a ARM processor LP2128 which is the main component of it. All the other interfaces of the system are connected to it. Divyansh Methi, Abhishek Chauhan, Divyanshu Gupta has developed an attendance system which used face recognition technique to mark attendance. This attendance system was mainly developed to track student attendance. The image is captured through a high definition camera. Faces of students are detected, segmented and stored for verification with database. After the successful match of faces, the attendance is marked by itself. Hasan U. Zaman, et al. also presented an idea on RFID based attendance system which is very simple in design, inexpensive and portable. Another type of attendance system was developed by Benfano Soewito, et. al. which used Voice Recognition and fingerprint on smart phone. This system is integrated with payroll system by which accounting department can easily calculate and report the salary included the overtime cost.

III. OBJECTIVE OF THE SYSTEM

The management of attendance record is one of the basic and crucial processes in any organization [3]. Among several objectives of making such an attendance system, the primary one is to make the attendance system digital and automatic to make it error free. This attendance system saves time. There is no place for human manipulation of the original data [4]. This attendance system has an in-built real time clock. The total attendance of a person for a particular period, day by day entry time and exit time is available altogether in excel format which is very useful for analysis purpose. Unlike other digital attendance systems available, this attendance system is less costly, more compact, design is simple [5].

IV. STUDY ON SYSTEM ARCHITECTURE

A. Basics on RFID

RFID is the acronym for Radio Frequency Identification. RFID system consists of three main parts.

- 1) RFID reader or scanner
- 2) RFID card or RFID tag
- 3) A computer to run software to interface above two [6]

The RFID card or tag contains electronically stored information in it. The scanner uses electromagnetic waves to read the data or information from the card or tag [7]. Now here comes a question how the tags receive energy to interact with the scanner. The tag can be Passive, Semi Passive, and Active depending on the source of power supply. Passive tags take energy from a nearby tag’s interrogative radio wave. Semi-passive tags contain a battery power supply for specific electronic circuits within the tag, but the communications interface circuitry is powered by the wireless link. Active tags have local power source, for example - a battery [6]. Fig.1 shows the block diagram showing working of RFID

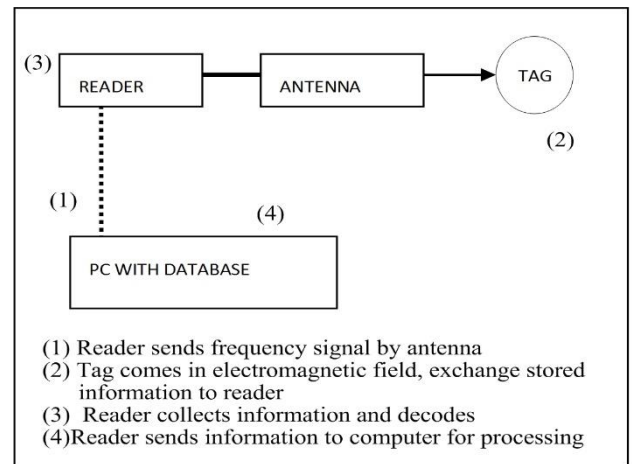

Fig.1 Block diagram showing working of RFID [8]

B. Study on ESP 8266

ESP8266 is a low-cost Wi-Fi microchip with TCP/IP stack and 32 bit Microcontroller capability. ESP8266 contains a built-in 32-bit low-power CPU, ROM and RAM [9]. It is a complete and self-contained Wi-Fi network solution that can carry software applications as a stand-alone device or connected with a microcontroller. This microchip, along with the microcontroller connects to a Wi-Fi network and interacts with other devices connected to it. This microcontroller can be programmed with several IDEs. The most commonly used one is Arduino IDE. ESP8266 works with a voltage of 3.3 Volt. It has total of 30 pins, 15 pins each on 2 sides. The Fig. 2 shows the pin configuration of ESP8266.

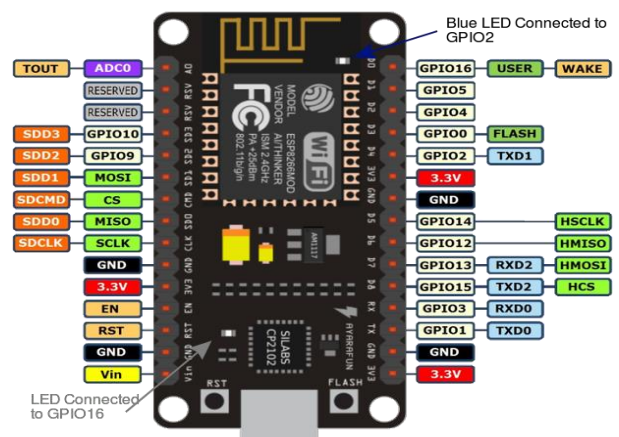

Fig. 2 Pin configuration of ESP8266 [10], [11]

This microcontroller connects to the Wi-Fi and transfers the data or information to server. This server can either be a Local Server or a Remote server or Global server [12]. If a local server is used then the server PC which has to be a Laptop only and desktops cannot be used in this case, and the microcontroller must be connected to the same Wi-Fi network and cannot be accessed through LAN or Internet. Else if a Remote Server is used then the server PC and the microcontroller can be connected in different network and the data is accessible through LAN or Internet also.

V. METHODOLOGY

The initialization and installation of the system is done by Hardware Installation and Software Installation separately.

A. Hardware Installation

The hardware connections can be made in a Bread board or in Vero board by connecting the junctions using Jumper cables. The primary hardware components used are ESP8266 or Wi-Fi module and RFID kit and it is shown in Fig. 3.



Fig. 3 Photograph of ES8266 and RFID Scanner used

The ESP8266 board along with the library is added to the Arduino IDE software. The connection between the Node MCU and RFID is shown in Fig. 4. The diagonal view of the system is shown in Fig. 5.

RFID Pin	ESP8266 Pin
SDA	D8
SCK	D5
MOSI	D7
MISO	D6
IRQ	No connection
GND	GND
RST	D3
3.3V	3.3V

Fig. 4 Pin connection of RFID scanner and ESP8266

After connections have been made, proper Wi-Fi settings are programmed and Port selection is done in the Arduino IDE.

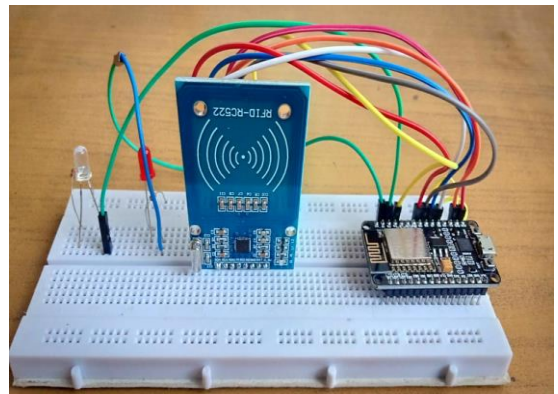

Fig. 5 Photograph of Diagonal view of the system

B. Software Installation

As discussed earlier the software part of the system mainly used in Date transfer from the RFID scanner to the server along with creation of the database. In this part comes the creation and utilization of either a Local Server or a Global Server.

A local server is created using Wamp Server software [13]. This software is configured using the IP address of the ESP8266 which is connected to the same Wi-Fi network in which the server PC is connected. The data, transferred by Node MCU via Wi-Fi to the server, can be accessed by that PC only. If the server PC is changed, the new PC has to have Wamp Server software installed in it. The new PC has to be configured again from beginning.

Now, if a Global server is used, a website domain is purchased and a website and web server is designed. The rest of the configuration process is almost same just the IP addresses is changed. The main reason of using a Remote server or a Global server is that the Wi-Fi module and the server PC need not to be connected in the same Wi-Fi network. Any particular PC can be used as a server PC and most importantly, it can be accessed through LAN apart from Wi-Fi network, which is a limitation in case of using a Local Server. Global servers are useful in case of student attendance monitoring. If a student scans his ID card in the school, his or her parent can track the attendance from their PC or smart phone.

Now, apparently here comes a question of security and privacy of the data if the website can be accessed through internet and if anybody has an access to it. For that purpose, the website has to be password protected so that authorized persons only have access to it. Moreover, the access to the website is public and the access to the server is doubtlessly private. So, the data is not that much vulnerable as it appears to be. Well, password protection of the website is a matter of future research. The top view of the system is shown in [Fig. 6](#).

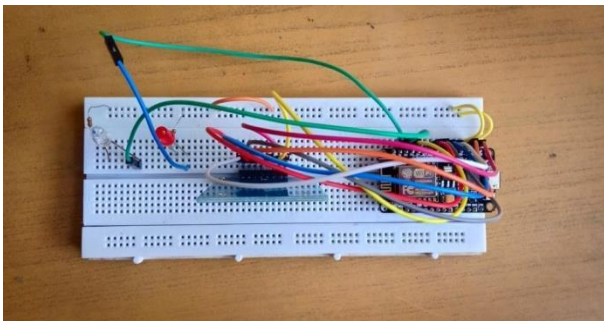

Fig. 6 Photograph of Top view of the system

A step-by-step installation of the system can be shown diagrammatically. The following [Fig. 7](#) depicts the same.

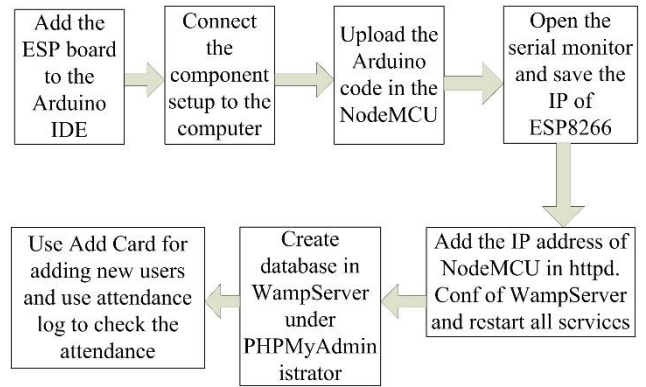

Fig. 7 Flow of the System implementation

VI. OUTPUT

From scanning the card to marking the attendance the entire system works is a compact flowchart [14] Output is the main reason for developing such a system and the basis on which we can evaluate the usefulness of the application. Smart Attendance system has been developed to show the report of attendance maintaining by the employees. The output will show daily, weekly, monthly report and consolidate report generated date, time to our end user. The report can even be converted to excel sheet if we want. The entire system has been made Wi-Fi enabled therefore the process will be fast and accurate than the conventional method. The user just needs to scan their ID cards which are the RFID cards to the reader and their attendance will automatically get saved in the database. The local server webpage output screen is shown in [Fig. 8](#).

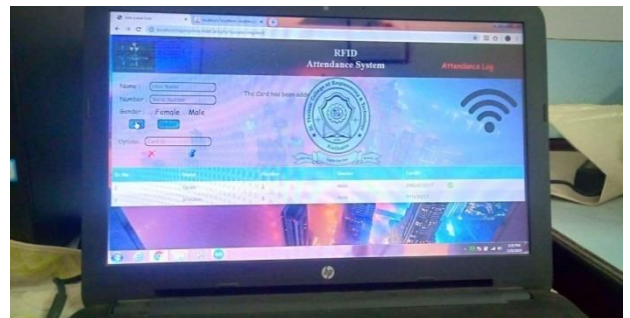

Fig. 8 Photograph of Local Server webpage Output screen

The database will show the time of arrival and departure and the employee id as a part of convenience. They can check their attendance records by visiting the website in case of Global Server and for Local server they can check it by showing their ID cards to the authorized person. Fig. 9 shows the output screen showing names of candidates of marked attendance.

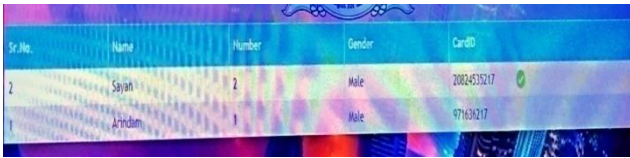

Fig. 9 Magnified view of output screen showing names of candidates of marked attendance

VII. RESULT ANALYSIS

A further analysis on the system output has been done to check the accuracy of the system. While a person enters in the premises, he scans his ID card. The “in time” is set at 10.00 a.m., which is supposed to be the scheduled entering time to the premises. It is seen from the excel sheet data of one day that the persons scanning their cards before 10.00 a.m. has been marked as “Arrived on time” in the server. And the person scanning their cards at 10.01 a.m. has been marked “Arrived late” in the server. The Fig. 10 has been prepared on the basis of the above data to see number of persons entering on time. Similar graphs can be prepared for a monthly basis or even yearly basis to monitor whether any person is consecutively being late in office or any student is regularly being irregular in classes.

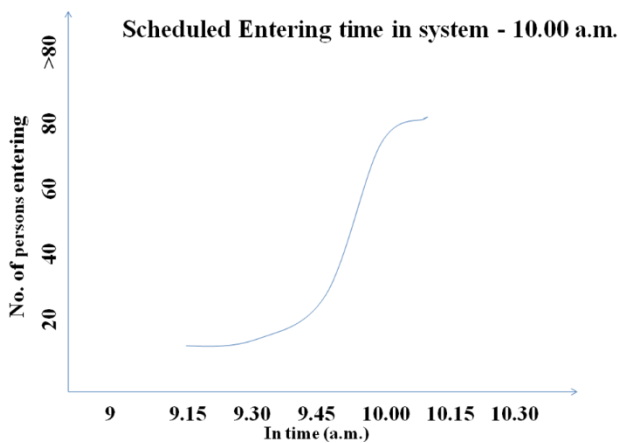

Fig. 10 Graph showing number of persons entering on time

Similar phenomenon happens while leaving the office too. If somebody leaves the office before time, “Left Early” is recorded in server; otherwise “Left on time” is recorded. Fig. 11 is prepared according the data available. From the graph it can be interpreted whether any person is regularly leaving the office before scheduled time and neglecting his work. However, this facility is not so very useful for student attendance monitoring.

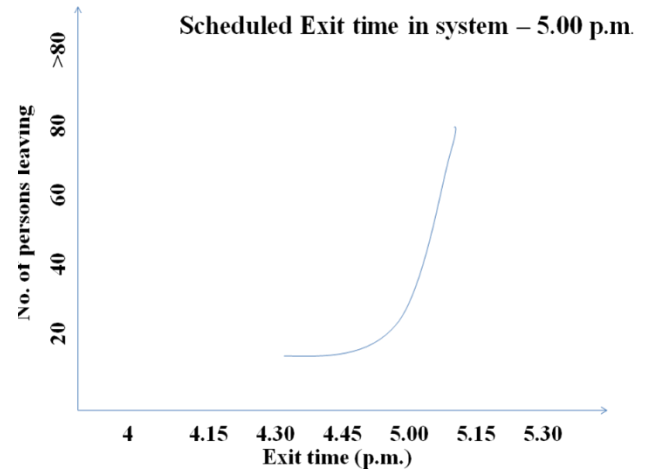

Fig. 11 Graph showing number of persons leaving on scheduled time

VIII. CONCLUSION AND FUTURE WORK

This application holds a huge scope of future enhancement and modification. Like in [15] voice recognition technique has been used, instead of that we can install a voice announcement system in this project. So whenever you logs in a message like “your attendance has been logged in or card is invalid” will be announced. A LCD screen can be installed with the system to display a message same as the voice announcement. Password protection of the website for Global server will be major incorporation to this system. Even person specific web account can be created so that one person can view his attendance records only and not of others’, to increase privacy of the data for Remote servers. So, in conclusion we have developed a smart attendance system which is Wi-Fi enabled that will help the authorities of private sector or organizations even government sectors to maintain the security and integrity of its vital data like employee attendance, office hours of employees etc., as the data is immediately transferred to a server thus getting saved

into a database. The authorities need not to worry about data getting misplaced or misused which will in terms help the organizations to build a better work ethics.

REFERENCES

- [1] MD Asdaque Hussain, Komirisetty Venkata Naga Krishna, Ramanulla Lakshmi Chandana, Velivela Krishna Chaitanya “An Efficient and Smart Attendance Management System”, International Journal of Innovative Technology and Exploring Engineering(IJITEE),ISSN:2278-3075, Volume 8, Issue 7, May, 2019.
- [2] T.S. Lim, S.C. Sim, M.M. Mansor “RFID based attendance system”, [IEEE Symposium on Industrial Electronics & Applications](#), 2009.
- [3] Rasika Naik, Maumita Mal, Shweta Koli, Aakash Karnani, Bhavesh Chetwani “Smart Attendance Management System (SAMS)”, Journal of Emerging Technologies and Innovative Research, , Volume 3, Issue 2, Feb 2016.
- [4] Divyansh Methi, Abhishek Chauhan, Divyanshu Gupta “Attendance System Using Face Recognition”,International Journal of Advanced Research in Science, Engineering and Technology, Volume 4, Issue 5, May 2017.
- [5] Hasan U. Zaman, [Jannatul Siffat Hossain](#), Tasnim Tamanna Anika, Deboshree Choudhury “RFID based attendance system”, 8th International Conference on Computing, Communication and Networking Technologies (ICCCNT), 2017.
- [6] S.Poonkothai, M.Pradeep, V.Vandhana “RFID based Academic Assessment Automation System”,International Journal of Advanced Research in Science, Engineering and Technology, Volume 3, Issue 10, October 2016.
- [7] https://en.wikipedia.org/wiki/Radio-frequency_identification.
- [8] Leandre Nsengumuremyi, Addepalli Sardhak, Vivek V “Smart Id Card System using RFID Technology” , International Journal for Research in Applied Science & Engineering Technology (IJRASET), Volume 6 Issue 5, May 2018.
- [9] Manan Mehta “ESP 8266: A Breakthrough In Wireless Sensor Networks And Internet of Things”, International Journal of Electronics and Communication Engineering & Technology (IJECET), Volume 6, Issue 8, Aug 2015.
- [10] [Ping Tan,Han Wu,Peng Li,He Xu](#) “Teaching Management System with Applications of RFID and IoT Technology”, Educ. Sci., Volume 8, Issue 1, Feb 2018
<https://doi.org/10.3390/educsci8010026>
- [11] <https://circuits4you.com/2017/12/31/nodemcu-pinout/>.
- [12] <https://devdojo.com/articles/local-vs-remote-servers>.
- [13] Wang Nina “Building the WAMP Platform”, Bachelor’s Thesis, Information Technology, Mikkeli University of Applied Sciences, May 2011.
- [14] Prof. K.K. Pandey, Snehal Shivaji Dumbre, Ketaki Arvind Kulkarni, Janhavi Raju Raikar, Vrushali Nandkumar Uplekar “RFID Based Smart Attendance System”, International Journal for Research in Applied Science & Engineering Technology (IJRASET), Volume 6 Issue 5, May 2018.
- [15] [Benfano Soewito, Ford Lumban Gaol, Echo Simanjuntak, Fergyanto E. Gunawan](#) “Smart mobile attendance system using voice recognition and fingerprint on smartphone”, [International Seminar on Intelligent Technology and Its Applications \(ISITIA\)](#), IEEE, 2016.