

# HyDelta

## **WP 1B Gas stations**

D1B.3b (question 212) – Explosion (preliminary work plan)

Status: final

## Document summary

### Corresponding author

Corresponding author(s)	Suzanne van Greuningen (MSc) Michiel van der Laan (MSc) Sander van Woudenberg (MSc)
Affiliation	KIWA Technology BV
E-mail address	<a href="mailto:Suzanne.van.greuningen@kiwa.com">Suzanne.van.greuningen@kiwa.com</a> <a href="mailto:Michiel.van.der.laan@kiwa.com">Michiel.van.der.laan@kiwa.com</a> <a href="mailto:Sander.van.woudenberg@kiwa.com">Sander.van.woudenberg@kiwa.com</a>

### Document history

Version	Date	Author	Affiliation	Summary of changes
1	09-02-2022	Sander van Woudenberg	KIWA Technology BV	First draft; concept
2	02-03-2022	Sander van Woudenberg	KIWA Technology BV	Second draft; processing comments
3	11-04-2022	Sander van Woudenberg	KIWA Technology BV	Third draft; processing comments

### Dissimilation level

Dissimilation level		
<b>PU</b>	Public	X
<b>R1</b>	Restricted to <ul style="list-style-type: none"> <li>- Partners including Expert Assessment Group</li> <li>- Other project participants including Sounding Board</li> <li>- External entity specified by the consortium (please specify)</li> </ul>	
<b>R2</b>	Restricted to <ul style="list-style-type: none"> <li>- Partners including Expert Assessment Group</li> <li>- Other project participants including Sounding Board</li> </ul>	
<b>R3</b>	Restricted to <ul style="list-style-type: none"> <li>- partners including Expert Assessment Group</li> </ul>	

### Document assessment

Partner	Name
Kiwa Technology BV	Rob van Aerde/ Sander van Woudenberg
Enexis	Raymond van Hooijdonk/ John Voogt
Rendo	Johan Jonkman
Alliander	Peter Verstegen
Stedin	Ricardo Verhoeve
Gasunie	Steffen Elgersma
NBNL, Gasunie, Kiwa, DNV, TNO and NEC	HyDelta Supervisory Group

## Executive summary

The starting point in the transition from natural gas to hydrogen is the need for the distribution and use of hydrogen to be at least as safe as natural gas. This document describes a literature review on realistic scenarios for the occurrence of flammable gas mixtures in and around gas stations. After completing the literature review, attention turned to the question of how to gain a better insight into these realistic scenarios, to the probability of the occurrence of flammable gas mixtures (in gas stations) and also to the hazardous situations that might arise as a result. This document is part research report (Section 4, literature review) and part research proposal (Section 5 et seq.). The first three sections are of a general nature and introduce readers to both the literature review and the research proposal.

The object of the process outlined above is to answer the following question: ‘How probable is the occurrence of an explosion in or close to a gas station?’. In other words, the probability of ignition and, as such, the occurrence of a hazardous situation (a flash fire, fire or explosion) too. The ultimate aim is to formulate recommendations for follow-up actions like follow-up research or the amendment of standards.

The objective of the research is to gain an insight into the distribution pattern of natural gas and hydrogen in the event of a leak in a gas station and also into the risk (probability and impact) that arises if an ignition source with sufficient ignition energy is added. This objective will be achieved by answering the following sub-questions:

1. Which scenarios in which a flammable mixture occurs in a gas station are realistic? <sup>1</sup>
2. Which impact needs to be taken into consideration in these scenarios? <sup>2</sup>

An inventory has been made of the information available from national and international research on explosions in gas stations for natural gas and hydrogen and from research on ignition sources. It reveals that much research has been done on the explosion behaviour of gas stations and the ignition potential of the equipment commonly used. However, the parameters used in the explosion behaviour studies are different to the parameters applicable in realistic scenarios. The leak sizes in most studies conducted previously were chosen with the object of facilitating an explosive gas-air mixture, in order to study the effects of explosions of gas cabinets. The focus was not on proving that the leak sizes chosen were in fact realistic or on performing tests with realistic leak sizes. Also, much research on ignition sources did not involve the ignition sources likely in the vicinity of a gas station (for example, a hair dryer or a bread toaster). This proposal has been written on the basis of the useful information obtained from these research projects. The results obtained from the literature review are described in Section 3.

The research described in this proposal consists of the following three steps:

---

<sup>1</sup> Section 6.2 describes the relevant parameters.

<sup>2</sup> The objective of the research described in the research proposal is to qualitatively describe this impact. The research data obtained must be sufficient to facilitate quantitative analyses (including calculations on issues like pressure waves and heat radiation) in follow-up research, if required

1. Identify realistic scenarios in which ignition/explosion situations could arise in or near gas stations/gas cabinets.

This will be done by organising an expert meeting in which all of the various relevant parameters are discussed. These parameters will include realistic leak sizes, weather conditions and potential ignition sources.

2. Perform Computational Fluid Dynamics (CFD) calculations.

In this step, leaks in gas stations will be modelled on the basis of the scenarios identified in Step 1. Calculations will be performed for each scenario, to establish whether and where an ignitable gas mixture will occur. One advantage of CFD calculations in comparison with practical tests is their ability to dictate specific scenarios, making it possible to manipulate input parameters to compare specific interests (wind speed and wind direction, for example). This facilitates the formulation of a shortlist of worst-case (or most-probable-case) scenarios to be tested. CFD calculations also make it possible to maintain the stability of parameters that are difficult to control during testing (wind speed and wind direction, for example). This improves the certainty of the outcomes of these calculations, particularly the probability of the occurrence of an ignitable mixture. This method also enables researchers to study the build-up of gas concentrations in and around a gas station or gas cabinet.

3. Experiments.

A shortlist of CFD calculation outcomes, including the worst-case scenario, will be verified by simulating the conditions modelled in a controlled experiment. An ignition source with sufficient ignition energy will be added to gain an insight into whether or not the mixture will actually ignite in the situations modelled and what the consequences are if it does.

## 1 Table of contents

Document summary .....	2
Executive summary .....	3
1. Background.....	6
2. Introduction.....	7
3. Objective.....	8
4. Literature review .....	9
4.1 Research on the probability of explosion/ignition.....	9
4.2 Research on the consequences of explosion/ignition.....	12
4.3 Research on relevant variables .....	14
4.4 Conclusions from the literature review.....	15
5. Suggestions for research .....	16
5.1 Options .....	16
5.1.1 Option A: model gas outflow (CFD).....	16
5.1.2 Option B: modify gas-station designs.....	16
5.1.3 Option C: practical tests .....	16
5.2 Recommendation .....	17
6. Proposal for a research design .....	18
6.1 Objective.....	18
6.2 Approach .....	18
6.3 Result to be delivered .....	22
6.4 Schedule .....	22
7 References.....	23

## 1. Background

As part of research question 212, HyDelta looked at the ventilation and explosion of housings for gas pressure regulating stations. At an early stage in this research, the decision was made to handle the ventilation and explosion components separately. For the ventilation component, measurements were performed on a  $\frac{1}{2}$ -m<sup>3</sup> cabinet and a 4-m<sup>3</sup> cabinet station to identify how the ventilation in these housings works with natural gas and hydrogen and various leaks. For the explosion component, the original plan was to select one housing, create a representative leak in it and then see whether the leak could lead to an ignition or explosion.

However, the approach above will not yield the insight required. The way in which it is possible to implement this approach and the impact it has depends on a whole range of different factors. For this reason, the decision was made, in consultation with the steering group, to start by studying the extent to which the explosion of housings for use in gas distribution has already been studied in other research programmes. This information and a literature review were then used to identify the specifics important for research on explosions. A plan of work was then written, plus a plan of action on further research on the subject of explosions. A number of options were put forward, including research to study gas outflow aided by finite element methods (CFD), changes to the housing design (to eliminate the accumulation of gas concentrations in the cabinet) and the performance of practical tests.

This document describes the literature review on realistic scenarios for the occurrence of flammable gas mixtures in and around stations. Attention then turns to how to gain a better insight into these realistic scenarios on the one hand and the probability of the occurrence of flammable gas mixtures (in gas stations) and the hazardous situations that might arise as a result on the other hand. As such, this document is part research report (Section 4, literature review) and part research proposal (Section 5 et seq.). The first three sections are of a general nature and introduce readers to both the research and the research proposal.

## 2. Introduction

The starting point in the transition from natural gas to hydrogen is the need for the distribution and use of hydrogen to be at least as safe as natural gas.

The objective of the research is to answer the following question: 'How probable is the occurrence of an explosion?'. In other words, the probability of ignition and, as such, the occurrence of a hazardous situation (a flash fire, fire or explosion) too. A flammable gas-air mixture will only occur if a leak is big enough for this to happen. A leak can lead to the accumulation of gas concentrations in the housing and then ignition - if an ignition source is present. If a mixture ignites, this could lead to a flash fire, fire or even an explosion.

The presence of a flammable mixture and an effective ignition source are the two preconditions for the possible occurrence of a hazardous situation. Ignition will only actually happen if the ignition source has sufficient ignition energy and is located in the vicinity of the flammable mixture. Whether or not a flammable mixture is able to develop depends on many factors: the type of gas, cabinet configuration (shape and content), cabinet location, gas pressure, ventilation (surface area and location), leak (hole surface area, flow rate and geometry), cabinet orientation relative to wind direction and weather conditions like temperature, wind direction and wind speed. All these factors influence the probability of the creation of a flammable mixture. Added to this, the development of the ignition response (an explosion, flash fire or fire) is not possible to manage or control. Besides managing the various factors, the order of magnitude is an important matter to take into account.

### 3. Objective

The objective of this research is to gain an insight into the distribution pattern of natural gas and hydrogen in the event of a leak in a gas station and also into the risk (probability and impact) that arises if an ignition source with sufficient ignition energy is added.

The insights obtained will be used to develop a risk analysis in which a comparison is made between the situation for natural gas and hydrogen. This objective will be achieved by answering the following sub-questions:

1. Which scenarios in which a flammable mixture occurs in a gas station are realistic?
2. Which impact needs to be taken into consideration in these scenarios?

The ultimate aim is to formulate recommendations for follow-up actions like follow-up research or the amendment of standards.



## 4. Literature review

In the past, Kiwa did research on the ATEX zoning of gas stations for natural gas. The objective of this research was to study the impact of ventilation and gain an indication of situations in which ignition could happen. The English national Hy4heat and H21 research programmes included research on explosions involving hydrogen too. The reports containing relevant information (relevant to some extent) are summarised below. These are then categorised into research on the consequences of explosion/ignition, research on the probability of explosion/ignition and research on relevant variables.

### Standards

- NEN 1059; 2019

### Hy4heat

- Gas Ignition and Explosion Data Analysis (202/1) [1]
- Ignition Potential Testing with Hydrogen and Methane (2021) [2]

### H21

- WBS3 Ignition Potential Testing (2021) [3]
- WBS4 Explosion Severity (2021) [4]

### Kiwa

- *Zonering gasstations bij bovenventilatie*, Van der Laan and Pulles (2016) [5]
- *Zonering van gasstations, fase 2*, Van der Laan and Pulles (2017) [6]
- *Ontsteekbaarheid waterstof-luchtmengsels* (2020) – Liander
- 1000 stations – NEN
- *Methaanemissie* - Netbeheer Nederland

The content of the research above will be discussed briefly in the subsections below.

### 4.1 Research on the probability of explosion/ignition

#### **NEN 1059**

Subsection 7.3.7 of NEN 1059, the standard for gas stations, focuses on the subject of ventilation. The inside of a gas cabinet must be ventilated to dilute any leakage gas and, by doing this, protect individuals who enter the station and limit the explosion risk in the station.

Amongst other things, this standard describes the need to protect ventilation openings from obstructions and the insertion of objects. Both of the above can be achieved by a so called labyrinth layout, or by protecting them with double plating or double gratings with mutually offset openings. The gap width of these openings may not be any less than 1 cm and no more than 2 cm.

Zoning and ignition sources are covered indirectly in Subsection 7.3.11 of the standard. This states the following:

- “The installation space in which a gas pressure regulating system is located is classified as hazard zone 1 or hazard zone 2 if it can be demonstrated that the ventilation rate in the installation space is more than 5 h<sup>-1</sup> (classification in accordance with NEN-EN-IEC 60079-10-1).
- An installation space may be classified as a non-hazardous area (NHA) if a gas leak with an opening of no more than 1 mm<sup>2</sup> at prevailing pressure in normal operating conditions is unable to create an explosive gas-air mixture in a quantity that is hazardous. See Appendix E.”

Appendix E of NEN 1059 (2019) identifies the situations in which an installation space can be deemed to be a non-hazardous area:

- “An installation space may be classified as a non-hazardous area (NHA) if a gas leak from a leak-hole size of no more than 1 mm<sup>2</sup> at prevailing pressure in normal operating conditions is unable to create an explosive gas-air mixture in a quantity that is hazardous.”
- “If the total surface area of the ventilation openings are as referred to in E.3, the installation space may be deemed to be a non-hazardous area (NHA).”

### **Gas station zoning with top ventilation & Gas station zoning – phase 2**

The research projects conducted by Kiwa for the purpose of the NEN 1059, as commissioned by Gasunie, focused on identifying the effectiveness of top ventilation and cross ventilation in non-accessible cabinet stations and cabinets [5] [6].

This was done by conducting practical tests in the open air with cabinet stations of ½ m<sup>3</sup> and 2 m<sup>3</sup>. Both research projects looked at the leak size. The research carried out in 2016 proceeded on the basis of a leak opening of 1 mm<sup>2</sup> at a pre-pressure of 4 bar and 6 bar. This resulted in leaks of 3 m<sup>3</sup><sub>n</sub>/h and 4.6 m<sup>3</sup><sub>n</sub>/h respectively. By varying the ventilation (top, top & bottom) and also the orientation in respect of wind direction (+90°, +45°, 0°, -45°, +90°), researchers sought to identify when a certain ignition source (in the form of flares around a cabinet) causes a gas to ignite. All tests were conducted with a leak size of 1 mm<sup>2</sup>, wind speeds lower than 2 m/s (which corresponds with wind force 2) and an outdoor temperature of between 5°C and 20°C.

The tests conducted in 2016 (Phase 1) showed that, both in the event of cross ventilation and top ventilation alone, fires and explosions can happen even if ventilation openings are in compliance with the standard and leaks foreseen in the standard. In virtually all of the tests, leaks were such that the gas concentration in the housing exceeded the upper flammability limit (UFL, approximately 15 vol% natural gas in air).

The results above were discussed in the norm committee, after which further research was done on leaks that actually occur in gas stations. Measurement data was suggested, to ascertain the maximum size of the leaks encountered. This showed that the leaks chosen in the research conducted in 2016 (3 m<sup>3</sup><sub>n</sub>/h and 4.6 m<sup>3</sup><sub>n</sub>/h) do not occur in practice. The maximum leak found to have been measured reliably was 0.6 m<sup>3</sup><sub>n</sub>/h. For this reason, additional measurements were carried out in 2017 with leaks of 0.5 m<sup>3</sup><sub>n</sub>/h and 1 m<sup>3</sup><sub>n</sub>/h; this is research phase 2. Although tests measured flammable (100% LFL) gas mixtures near the ventilation openings multiple times, there were no fires or explosions.

The research projects above also revealed that temperature, wind direction and wind speed have a major influence on the distribution behaviour of the gas in question. Distribution is chaotic, even at low wind speeds (see Figure 1). It was not possible to check these weather influences via the test apparatus.

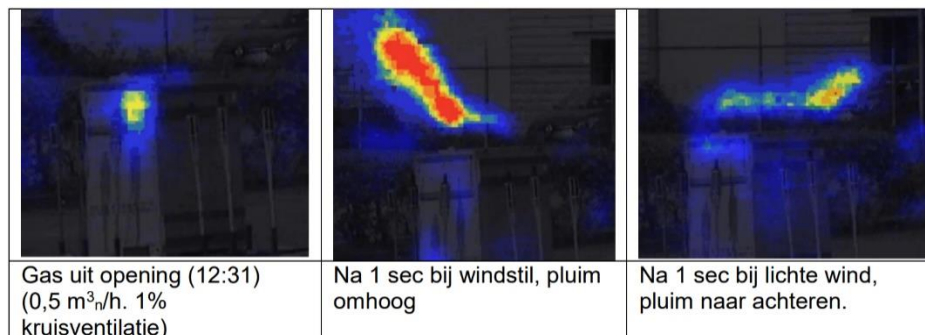

Figure 1. Non-uniform distribution of gas around the cabinet and the cabinet station.

### 1000 stations

At the time of writing this report (January 2022), research commissioned by the NEN 1059 standard committee was being conducted on gas concentrations (natural gas) in gas stations. In this research, the maximum concentration of gas in the vicinity of ventilation openings was being measured in 1,000 district stations in the field. The results of this research are expected later this year.

### Methane emission

From the point of view of methane emissions, research commissioned by Netbeheer Nederland is also seeking to identify indicators for the mean gas-leak size in gas stations. The European indicator currently applicable is 924 m<sup>3</sup> of natural gas (this is 751 m<sup>3</sup> of methane) per station per year, or 105 litres of natural gas per hour [7]. This indicator is based on a small, outdated set of measurements taken at a number of German district stations. Preparations are underway for further research to establish reliable Dutch emission factors, including emission factors for gas stations. Identifying the mean leak size will make it easier to estimate methane emissions. However, a mean does not provide any information about the biggest leak probable. Having said this, it is possible that some of the same information sources can be used to determine the mean leak and the biggest leak probable.

## 4.2 Research on the consequences of explosion/ignition

### Gas ignition and explosion analysis (Hy4Heat, 2021) - literature review

The objective of this literature review was to identify factors that influence the consequences of an ignition of (0-25 vol%) of natural gas and hydrogen. The results were used to ascertain whether the situations studied could be extended to cover situations in the built environment.

The explosion tests in the literature reviewed were carried out in various areas. For example: a Fire Investigation Box, a garage and a 25-m<sup>3</sup> housing where both the volume of the containment as well as the ventilation are considered a variable. Apart from these two variables, other variables like gas pressure, weather conditions or leak sizes (used in each explosion test) were not specified.

An explosive mixture was deliberately created and ignited in certain spaces, after which overpressures were measured and analysed. An explosive environment was deliberately created in this research. However, the scope of this research did not extend to the extent to which the explosive mixture studied could actually occur (in practice). As such, the realistic parameters to be determined in the follow-up research described in this document (parameters for the leakage flow rate, amongst other things) are not possible to deduce from this English research. No consideration was given to factors like wind speed or temperature either.



*Figure 2. A housing from the Hy4Heat report entitled 'Gas ignition and explosion analysis' (2021).*

### WBS4 Explosion Severity (H21, 2021)

This research focused on analysing the consequences of explosions in various gas stations for hydrogen. The development of pressure waves and the damage caused by explosions were particularly key. Practical outdoor tests were used to test the impact of explosions on gas stations of different sizes in England.

An explosive environment was deliberately created in this research. The leaks simulated for the explosion tests had a diameter of 3-13 mm, because of which very big leakage flow rates were generated. This led to high concentrations of hydrogen and the certainty of an explosive mixture in the cabinets. The ‘temperature’, ‘wind-direction’ and ‘wind-speed’ environmental variables were measured but not included in the analysis of the results. The scope of this research project did not extend to the extent to which the explosive mixture studied could actually occur (in practice). As such, the realistic parameters to be determined in the follow-up research described in this document (parameters for the leakage flow rate, amongst other things) are not possible to deduce from this English research.



30



*Figure 3. Exploding cabinet station from H21 report ‘Evaluation of Experimental Data from Phase 1B – WBS4 Explosion Severity’ (2021).*

### 4.3 Research on relevant variables

#### **The flammability of hydrogen-air mixtures (2020) – commissioned by Liander**

In this research, Schlieren technology was used to identify the flammability of hydrogen-air mixtures with different ignition sources and gas concentrations. Hydrogen concentrations of 4 vol%, 6 vol%, 8 vol% and 10 vol% were exposed to a glow plug, a piezoelectric element, a light switch, a doorbell and a cigarette.

It was found that the way in which the ensuing ignition developed was independent of the ignition sources used. It is determined instead by the concentration of gas (4-6 vol% nothing, 8 vol% gentle, directed upwards; 10 vol% faster, turbulent, in every direction). A cigarette lacks the ignition energy necessary to ignite a mixture of 10 vol% hydrogen.

#### **Ignition Potential Testing with Hydrogen and Methane (Hy4Heat, 2021)**

This research studied the probability of the ignition of hydrogen-air mixtures via domestic appliances. The results obtained were compared with the probability of the ignition of methane-air mixtures. Researchers attempted to ignite hydrogen and methane concentrations of 5.90 vol%, 8.9 vol%, 17.8 vol%, 26.6 vol% and 29.6 vol% via sources like a hair dryer, a microwave, different types of bulb and a ventilator.

The above resulted in a table of domestic appliances that may or may not cause specific gas-air mixtures to ignite. Almost all hydrogen ignitions started at the very lowest concentrations and ignition was occasionally slow to start. The diffusion of the gas-air mixture in an appliance is probably the controlling factor here.

#### **WBS3 Ignition Potential Testing (H21, 2021)**

This is the same type of research as that conducted in the Hy4Heat programme [2], but it tested different ignition sources. Hydrogen and methane in concentrations of 5.9 vol%, 8.9 vol%, 17.8 vol%, 26.6 vol% and 29.6 vol% were exposed to an ignition source like a mobile phone, cigarette, static electricity, the sparks from grinding tools or a starter motor.

This resulted in a table of appliances that do or do not cause various gas-air mixtures to ignite. With the exception of the starter motor, the following applied for all of the appliances: (1) Ignition occurred at the lowest concentrations or (2) none of the mixtures ignited. The time necessary to reach the ignition source in the appliance adds a time dependence to ignition. Results for the starter motor were mixed, probably due to its analog nature and the time the mixture needs to reach the starter motor.

#### 4.4 Conclusions from the literature review

To summarise, much research has been done on the ignition behaviour of natural gas and hydrogen, whether or not leading to an explosion. However, this research does not substantiate the probability of a situation in which ignition could actually occur. The leak sizes from studies that looked at the consequences of explosions do not reflect values that are realistic in the field. A leak size of 1 mm<sup>2</sup> was maintained in the studies on the zoning of cabinet stations and cabinets, as specified in NEN-1059:2019. Here too, the question is whether this is a representative size. Additional measurement data to be carried out on leakage flow rates from the field as part of the '1000 stations' research will provide more guidance.

The *"Zonering gasstations bij bovenventilatie"* and *"Zonering van gasstations, fase 2"* research projects reveal the distribution behaviour of gas when gas leaks are created on the basis of definitions that include some degree of realism. The major influence of wind speed and wind direction became clear in particular. Both of these factors are difficult or impossible to control. It is important to make good choices in the practical tests proposed to ensure that the results obtained are realistic.

A burning cigarette may be the most realistic of the ignition sources tested. However, to test the probability of ignition as envisaged, the ignition source must be an accurate, fixed variable, such as the flares used in research on the zoning of gas stations [5] [6].

## 5. Suggestions for research

The first challenge in respect of tests on explosions/ignitions in gas stations is to formulate realistic values for input parameters: the leakage flow rate, wind speed, wind direction and temperature. It is critical to design (practical) tests in which weather influences can be controlled effectively. The three tests below are suggestions for research; each has its own methods, advantages and disadvantages.

### 5.1 Options

#### 5.1.1 Option A: model gas outflow (CFD)

This involves modelling the distribution behaviour of gas aided by finite element methods, using simulation software like Ansys or Start CCM+. The objective is to build a mathematical model of a gas pressure regulating station and its environment. The gas station is a detailed model of the housing and ventilation ducts and the content of the station: the circumference of components like the filter housing, the regulator and the connecting pipework. The environment around the station is modelled as a grid from which fresh air (wind) is supplied and towards which the leakage gas can distribute itself. In CFD calculations, the temperature of the environment and also the wind direction and wind speed can all be specified. In the housing, gas (natural gas or hydrogen) is then injected via a leak. This makes it possible to show the following:

1. The occurrence of a gas-air mixture, whether or not flammable;
2. The distribution of the gas-air mixture in and around the cabinet station.

In CFD calculations, the temperature of the environment and also the wind direction and wind speed can all be specified. Because of this, a test matrix can be modelled with different variables that can be used to draw up a shortlist of realistic and critical values as input for practical tests.

CFD calculations make it possible, based on the energy level required for the ignition source, to model the distribution pattern of gas-air mixtures both inside and outside the housing. These distribution patterns can be depicted in the form of iso contours, but many different visualisation options are possible in the software used. For each set of input parameters, they show where gas mixtures are created at a concentration of, 10% LEL and 100% LEL, for example, and also stoichiometric gas-air mixtures.

No provision has been made to model the impact of ignition (pressure waves and heat intensity, for example), if any. This is a separate calculation. However, the data obtained can be used to perform a calculation of this nature in any follow-up research.

#### 5.1.2 Option B: modify gas-station designs

When modifying gas-station designs, the intention will be to remove the possibility of ignition by influencing the gas outflow point (which can be achieved by placing a high pipe on the housing, for example). The effectiveness of new or modified designs would then be possible to test in practice.

This approach removes the probability of ignition, because of which temperature, wind direction and wind speed no longer play a crucial, influencing role. It is advised not to study this option further because the present research focuses on existing (not modified) gas stations. However, design modification could be the consequence if this research shows that the stations are not suitable.

#### 5.1.3 Option C: practical tests

This would involve the performance of research identical to the practical tests done for the research on the zoning of gas stations for natural gas. Although temperature, wind direction and wind speed



cannot be controlled, shielding might minimise their influence. A hydrogen tracer that facilitates visualisation with a camera has not been found yet.

## 5.2 Recommendation

Based on the advantages and disadvantages of the three options set out above, it is advised to start with research A: modelling situations to arrive at a shortlist of values for the practical tests. This will make it possible to show which scenarios ought to be tested in practice and gain a sense of the influence that the significant variables have. The data obtained will facilitate a targeted decision to do just a limited number of tests. These tests could be carried out in the field (Option C) to ascertain whether practice does actually support theory. Before modelling or doing the practical tests, the input parameters for realistic scenarios will need to be defined. A suggested research design is elaborated on below.

## 6. Proposal for a research design

### 6.1 Objective

The objective of this research is to gain an insight into the distribution pattern of natural gas and hydrogen in the event of a leak in a gas station and also into the risk (probability and impact) that arises if an ignition source with sufficient ignition energy is added. The insights obtained will be used to develop a risk analysis in which a comparison is made between the situation for natural gas and hydrogen.

### 6.2 Approach

It is proposed that the research consist of a combination of Option A (modelling) and Option C (practical tests). Activities are also being planned to identify the input parameters necessary. In outline, the research proposed will consist of the following phases:

#### Phase 1. Identify realistic scenarios in which an ignition/explosion could happen.

It is not possible to arrive at an exhaustive list of realistic and hazardous scenarios from the research projects cited in this document; it appears that this is difficult to do. If a task seems too big to handle, it often helps to break it down into smaller pieces. It is also beneficial to seek out ways to collaborate with others, to utilise each other's knowledge as much as possible.

Given the reasons above, it is proposed to organise a workshop in which possible realistic scenarios are discussed per parameter. The following questions will be covered in this workshop:

- What do we mean by a 'realistic' scenario?
  - o Where does it lie between "This has never happened yet, but we can imagine it happening" and "This happens on a daily basis"? In preparation for the workshop, Kiwa will carry out an analysis on the basis of the Nestor database to gain an insight into incidents involving gas flow at gas stations;
  - o Could the term 'realistic' be replaced with a quantitative risk? For example, via a requirement from a standard or the risk matrices for the network;
  - o Which gas-flow-related risks and control measures apply at gas stations? To answer this question, the bowtie gas stations will be used as a guide during the workshop.
- Scenario parameters:
  - o What is a 'realistic' leak size? (for example, a hole size of 1 mm<sup>2</sup> (NEN 1059), 1 m<sup>3</sup>/h (Phase 2 of research by NEN/Kiwa), other insights?) How often does this leak size occur? (hour/year/station);
  - o What is the worst weather situation possible? How often does this weather situation happen? (hour/year/station). In preparation for the workshop, Kiwa will ascertain which weather-situation-related assumptions are included in the existing calculation method;
  - o What is the worst (poorest-ventilating) housing? Which station types do the network operators use and how big is the population per type?
  - o Which ignition source is the most realistic? (suggestion: a burning cigarette). How often would this be in the vicinity of the ventilation opening of a station? (hour/year/station);
  - o Which ignition source is most realistic in combination with an ignition energy that is sufficient to cause a hydrogen mixture to ignite? (suggestion: loitering youths or

hooligans with fireworks). How often could they be in the vicinity of the ventilation opening of a station? (hour/year/station);

- Which scenarios will be chosen to research further with CFD calculations or practical research? (objective: thorough research, bearing in mind the cost aspect).
- Other questions:
  - How will the risk analysis be developed and which level of detail will be pursued?
  - Which possibilities are there to reduce the effects of a fire or explosion (for example, extra ventilation or an explosion hatch) and how feasible would they actually seem to be? (note: this information is not necessary for the models or the practical test. However, it may yield useful information for later recommendations).

It is recommended that a discussion document on the parameters above is prepared prior to the workshop above. The object of this discussion document will be to support discussion during the workshop. Its contents will include assumptions about weather situations in existing calculation models and illustrations of existing ventilation ducts in stations. If new information emerges about realistic leak sizes in stations between the writing of this document and the actual workshop, it will be logical to include this information in the discussion document.

The workshop is not expected to resolve all of the various uncertainties. The expectation is that the answers to many questions will be no more than estimates, but that it will be possible to define scenarios after this workshop. The outcomes of the workshop will be set out in a report.

#### Phase 2 – modelling (previously referred to as: Option A)

In this phase, CFD calculations will be used to model the scenarios defined in Phase 1. It is not currently possible to estimate how many scenarios there will be or the extent to which it will be possible to model and calculate all of the various scenarios. Individual scenarios could also require more than just one calculation. This could be the case, for example, if the wind direction or the exact location of a leak in the station cannot be determined in advance and the object of modelling is to show in which detailed situations an ignitable mixture will or will not occur. The number of scenarios to be calculated will be determined in consultation with the guidance group. Models and calculations will be prepared per scenario, with the object of answering the following questions:

- Will an ignitable mixture occur in this scenario (outside the housing) and what are the contours of this mixture? Or: in which detailed situations will an ignitable mixture occur in this scenario?
- What will the consequences of ignition be (how big will the pressure wave be)?
- After which changes to this scenario will an ignitable mixture no longer be the case? (for example: if the leak is factor x smaller than assumed. This could be valuable input for any standards).

#### Phase 3. Practical research

Both CFD calculations and practical tests have their strengths and weaknesses. The advantage of CFD calculations is that they make it easy to calculate (a whole range of) different scenarios. Also, it is necessary to understand which processes and parameters play a role before a good model is possible. These two factors ensure that calculations are able to provide an extensive insight.

The advantage of practical tests is that they are less subject to so-called 'unknown-unknowns'. However, in practice, it will be impossible to eliminate unknown phenomena, or seemingly unimportant parameters, that do not form part of a CFD model. Therefore, practical tests are a more

precise approximation of reality. However, (destructive) practical tests have a limited ability to test different parameters and are also subject to a number of practical challenges (safety, control, logistics, measurement accuracy and timing, etc.).

The object of the practical tests is to validate or modify the outcomes of the CFD modelling and calculations. We propose the following set of parameters:

- Stations:  $\frac{1}{2}$ -m<sup>3</sup> cabinet. Type according to scenario (“the poorest ventilating, often used”);
- Location of leak in the cabinet: worst-case according to CFD;
- Leak size: accumulation:
  - o First test: leak size that is safe according to calculation. If no explosion, then:
  - o Leak size in line with the scenario defined. If no explosion, then:
  - o Increase gradually by 25%.
- Ignition sources: ignition source with sufficient ignition energy (accurate ignition source);
- Wind speed: must be controlled, but this will almost impossible in an outdoor environment.  
Options:
  - o Shield the test location from wind as much as possible (for example, via sea containers in which a sheltered environment can be created);
  - o Accept wind as a given. Measure wind direction and speed and, after testing, use as input in the CFD models for verification purposes.
- The following must be measured:
  - o Hydrogen flow;
  - o Wind speed and direction;
  - o Pressure-wave explosion;
  - o Video (visual and gas camera).

The relevant consequences will be noted and described in each test (for example: no ignition, fire or explosion).

The Twente Safety Campus would seem to be the most suitable location.

## Schematic representation of apparatus

The apparatus is shown schematically in figure 2 below. It consists of the following components:

1. Gas bottles containing hydrogen and methane;
2. A Mass Flow Controller (MFC) to create a leak with a controlled flow rate;
3. A remote switch for glow plugs and ignition sources around the gas station;
4. A gas supply hose from the gas bottles, via the MFC, under/through the container to a leak inside the gas station;
5. Sea containers around the station to avoid the influence of wind and manage risks for the environment;
6. The gas station in which there is a leak;
7. A weather station for the wind and temperature in the containers (to be replaced after each explosion);
8. A pressure indicator (PI) to register the shock wave (in the possession of the Twente Safety Campus);
9. A video camera and gas camera on a raised plateau outside the containers.

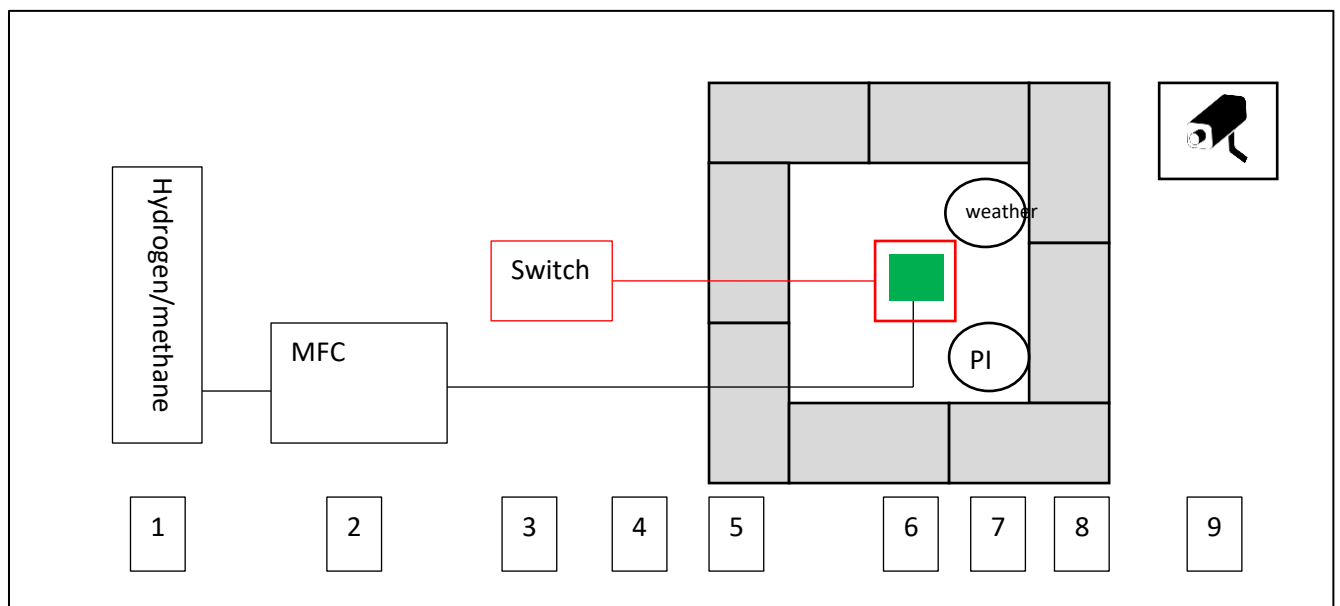

Figure 2. Schematic representation of test apparatus (top view)

### 6.3 Result to be delivered

The report to be delivered will contain the following components:

1. A description of the realistic scenarios possible when a leak occurs in a gas station, including the quantitative parameters used as input for the CFD calculations;
2. A report on the CFD calculations, plus the relevant starting points, figures and conclusions;
3. A report on the practical tests;
4. Conclusions in which the risks are described and a comparison made between the risks of leakage presented by natural gas and hydrogen (risk analysis);
5. Recommendations for follow-up actions. For example, follow-up research and amendments to standards.

### 6.4 Schedule

It is expected that it will take a total of 32-36 weeks to implement research projects A and C, depending on the various steps and the consultation structure.

## 7 References

- [1] N. Hardy, P. McLaughlin, J. Thomas en G. Orr, „Gas Ignition and Explosion Data Analysis,” Hy4Heat, Kiwa Gastec, 2021.
- [2] R. C. RobCrewe, M. Johnson en D. Allason, „Ignition Potential Testing with Hydrogen and Methane,” Hy4Heat, GL Industrial Services UK Ltd., 2020.
- [3] C. Waghorn, A. Phillips en M. Acton, „Evaluation of Experimental Data from Phase 1B Data from Phase 1B – WBS3 Ignition Potential,” Northern Gas Networks, H21, Northern Gas Networks, 2020.
- [4] C. Robinson, M. Johnson en M. Acton, „Evaluation of Experimental Data from Phase 1B – WBS4 Explosion Severity,” DNV GL Oil & Gas, H21, Northern Gas Networks, 2020.
- [5] K. Pulles en M. van der Laan, „Zonering gasstations bij bovenventilatie GT-160124,” Kiwa Technology, 2016.
- [6] K. Pulles en M. van der Laan, „Zonering van gasstations, fase 2 - GT 170233,” Kiwa Technology, 2017.
- [7] DBI, „Methane Emission Estimation Method for the Gas Distribution Grid (MEEM),” DBI, 2018.