

# Thermodynamics of Two-phase Liquid-Liquid Distribution of Metal Complexes Studied by the AKUFVE-Technique

JAN RYDBERG

Department of Nuclear Chemistry, Chalmers University of Technology, Fack, S-402 20 Goteborg 5, Sweden

After pointing out the importance to industrial chemistry of the particular research area, the thermodynamics of solvent extraction is discussed, particularly with reference to the theory of regular solutions. The experimental problem of determining  $\Delta H$  and  $\Delta S$  for the distribution of uncharged metal complexes between two immiscible solvents is indicated. The application of the AKUFVE-technique will be shown to be very useful; the AKUFVE is a new semi-automatic device for rapid and accurate collection of solvent extraction data.

The chemical forces involved in solvent extraction are quite weak, and  $\Delta H$  and  $\Delta S$  thus rather small. The experimental data must therefore be interpreted with great care and supporting information collected from solubility, vapor pressure, structural and other studies. Values of  $\Delta H$  and  $\Delta S$  for the distribution of metal acetylacetonates between different organic solvents and aqueous solutions of varying ionic strength will be given and commented upon.

## Scope of the problem

About 100 years ago it was discovered that under certain conditions metals could be extracted from their aqueous solutions into organic solvents. Because different metals showed different extractabilities, the technique of solvent extraction was found to be very effective for separating metals. Solvent extraction has therefore become extensively used in analytical chemistry, and several textbooks have been written thereabout.

In the 1950's solvent extraction came into practical use, first for the production of very pure uranium.<sup>1</sup> Since then numerous industrial solvent extraction processes have been designed and successfully put into operation for the production of other metals, as well as pure acids.<sup>2</sup> Some of the processes are of very large scale, e.g. the extraction of 60,000 tons of copper per year in Zambia.<sup>3</sup> At the present solvent extraction is entering a new promising field: the recovery of metals and acids from industrial waste streams.<sup>4</sup>

All these applications have of course led to extensive research on solvent extraction.<sup>5</sup> The extraction phenomenon *per se*, that is the distribution of the metal between the two liquid phases as a function of chemical variables, have in most cases been explained by assuming the formation of a number of distinctive metal complexes. However, the information gained so far is not sufficient for prediction of extraction behaviour in new systems, although from solubility

parameter<sup>6</sup> data some good predictions can be made for the distribution of one specific metal complex between a series of similar solvents.<sup>7</sup>

One area which has been almost devoid of research is the thermodynamics of solvent extraction. Still it is a field of both practical and theoretical importance.

The practical importance stems from the fact that most literature information has been gained at ambient laboratory temperature, or at 25°, while in the industry the process streams often have quite different temperatures. Because the distribution coefficients (defined as the concentration of the metal in all species in the organic phase divided by its concentration in all species in the aqueous phase;  $D = [M]_{org}/[M]_{aq}$ ) often are very temperature dependent, the temperature dependency of the extraction process, which is to be incorporated into the industrial process flow, must be known in order to optimize the process.<sup>8</sup>

The theoretical interest is due to the fact that the forces involved in the distribution of the metal complex are both very weak and complicated, and therefore not so well known, although the effects on the distribution ratio are very large. For example, a change in the distribution ratio of a factor of two involves an energy change in the system of only 1.7 kJ/mole (or 0.4 kcal/mole). In addition to semi-weak chemical interactions like electron donor-acceptor reactions, also hydrogen bonding, dipole and dispersion forces are involved. Very little is known about

enthalpy and entropy changes in distribution reactions, and the connection between such thermodynamic data and the specific type of interaction. The purpose of our approach is to investigate if systematic determinations of  $\Delta H$  and  $\Delta S$  in distribution equilibria can throw more light upon the particular interactions, which govern the distribution constants of the complexes. It may in this context be mentioned that these weak interactions obviously also are of great importance *in vivo*.

The reason why information on thermodynamics of solvent extraction is almost nil, is at least partly due to experimental difficulties. The straight-forward approach with calorimetric measurements is not so easy to carry out in a two-phase liquid-liquid system; for example gas volumes must be avoided. Further, several different equilibria are involved in the distribution experiments (stepwise metal complex formation, protonation of the ligand in the aqueous phase, etc.), each equilibria contributing to the heat change. Because some of the equilibria involve ionic or covalent bonding in the aqueous phase, with enthalpy values at least 10 times larger than for the van der Waals interactions involved in the distribution of the uncharged metal complex, it will be difficult from calorimetric measurements to single out the heat contribution from the distribution step only.

A further complication with calorimetric experiments is that they require macroscopic amounts of the reacting species. Unfortunately, most metal complexes of the kind considered here are only sparingly soluble in organic solvents.

The other technique to establish  $\Delta H$  and  $\Delta S$  is to determine the temperature dependence of the free energy change ( $\Delta G$ ) of the distribution only. This can be done if the proper conditions are chosen, as shall be described in detail below. With radioactive isotopic tracer for the metal, the distribution of the metal is rather easily measured. Still such experiments are rather laborious, because it is necessary to investigate the system over a sufficiently large range of concentrations in order to establish the various metal species involved in the reaction. Adding that such dependencies must be measured at various temperatures in order to obtain  $\Delta H$  and  $\Delta S$  for the reactions, the amount of labor may become prohibitively high, using present conventional test-tube technique.

Fortunately, this may no longer be so. Through the introduction of the AKUFVE-technique,<sup>9</sup> the

experiments may be speeded up by a factor of 100 or so. The precision in the measurements is also improved. To take full advantage of this technique, the chemical equilibria must be reached quite rapidly (within a few seconds), and the solute concentration in each phase measured radiometrically.

We have limited our research to uncharged complexes between metal ions and organic ligands, mostly of the chelate type. This simplifies the experimental technique, but still gives quite a variability among solute and solvents that can be investigated. In this paper experimental data will only be presented for acetylacetone and its uncharged complexes with Cu(II), Zn(II), Co(III), Th(IV) and Np(IV).

In most of these metal complexes, the central atom is fairly well shielded from the solvent, which mainly 'sees' the organic surface. The forces between the complex and its environment remains in the outer adjacent portions, which can be varied in many ways. For example, in the series  $ZnA_2$ ,  $CoA_3$ , and  $NpA_4$ , where A is acetylacetone, the molar volume increases, while at the same time the structures for the complex changes from tetrahedral to octahedral to antiprismatic (or dodecahedral). By substitution in A, e.g. to form benzoylaceton, dibenzoylmethan, etc., further changes are introduced in the solute. There is hardly any limit to the kinds of interactions which may be brought about through introduction of reactive groups containing O, N, Cl, etc. in the ligand.

In our experiments trace metal concentrations are used as far as possible. The advantage of this is that changes in the metal distribution will not influence the material balance for other reagents, and thus the activity factors of each phase can be kept constant, at least in the first approximation.

In the following we shall analyze the problem in more detail, and report the results so far collected.

#### The distribution equilibrium<sup>10</sup>

The uncharged metal complex  $ML_z$  is formed in a step-wise manner in the aqueous phase from the metal ion  $M^{z+}$  and the singly charged ligand ion  $L^-$ . The equilibrium constants for the reactions are

$$\beta_n = [ML_n]/[M][L]^n \quad (1)$$

omitting ionic charges. The complex which can be extracted into an organic solvent, is  $ML_z$ , while the coordinatively saturated complex with respect to the

ligand is  $ML_n^{z-n}$ . The equilibrium for the distribution of the uncharged complex between the organic and aqueous phases is given by



$$\lambda_z = [ML_z]_{org}/[ML_z]_{aq} \quad (2)$$

Brackets are used to indicate concentrations, and index *org* and *aq* to which phase the uncharged species belong ; all charged species are assumed to be in the aqueous phase ; charge and index is then omitted. The measured distribution of the metal between the two solvents is

$$D = [M]_{org}/[M]_{aq} \quad (3)$$

where  $[M]_{org}$  and  $[M]_{aq}$  refers to all metal species in each phase. From these equations one finds that the distribution ratio of the metal must be

$$D = \lambda_z \beta_z [L]^z \frac{\sum_0^N \beta_n [L]^n}{\beta_0} \quad (4)$$

With tracer concentrations of the metal, the free ligand concentration,  $[L]$ , in the aqueous phase

depends on its protonation in the aqueous phase (acid diss. consta.  $k_a$ ) and the distribution of HL between the two phases (dist. const.  $k_d$ ). Thus

$$[L] = k_a k_d^{-1} [HL]_{org} [H]^{-1} \quad (5)$$

Thus  $D$  will depend only on the concentration of the reagent HL in the organic phase, and the pH of the aqueous phase, in a first approximation.

Fig. 1 shows how  $D$  varies with  $[H]$  and  $[HL]_{org}$  for the systems Cu(II)- and Zn(II)-acetylacetonate in 1 M NaClO<sub>4</sub>/benzene. It can be shown from eqn. 4 that on the plateau  $z=n$ , i.e. both the organic and aqueous phases are completely dominated by the uncharged complex  $ML_z$ , and the  $D$ -value is thus equal to  $\lambda_z$ . Thus in this concentration region of  $[H]$  and  $[HL]_{org}$ , the temperature dependence of  $D$  is also the temperature dependence of  $\lambda_z$ . Small changes in  $[H]$  and  $[HL]$  caused by the temperature dependence of  $k_w$  (the ionic product of water), and of  $k_a$  and  $k_d$  will in the plateau region not influence on  $\lambda_z$ , as long as  $ML_z$  dominates both phases. In calorimetric measurements these changes would contribute to

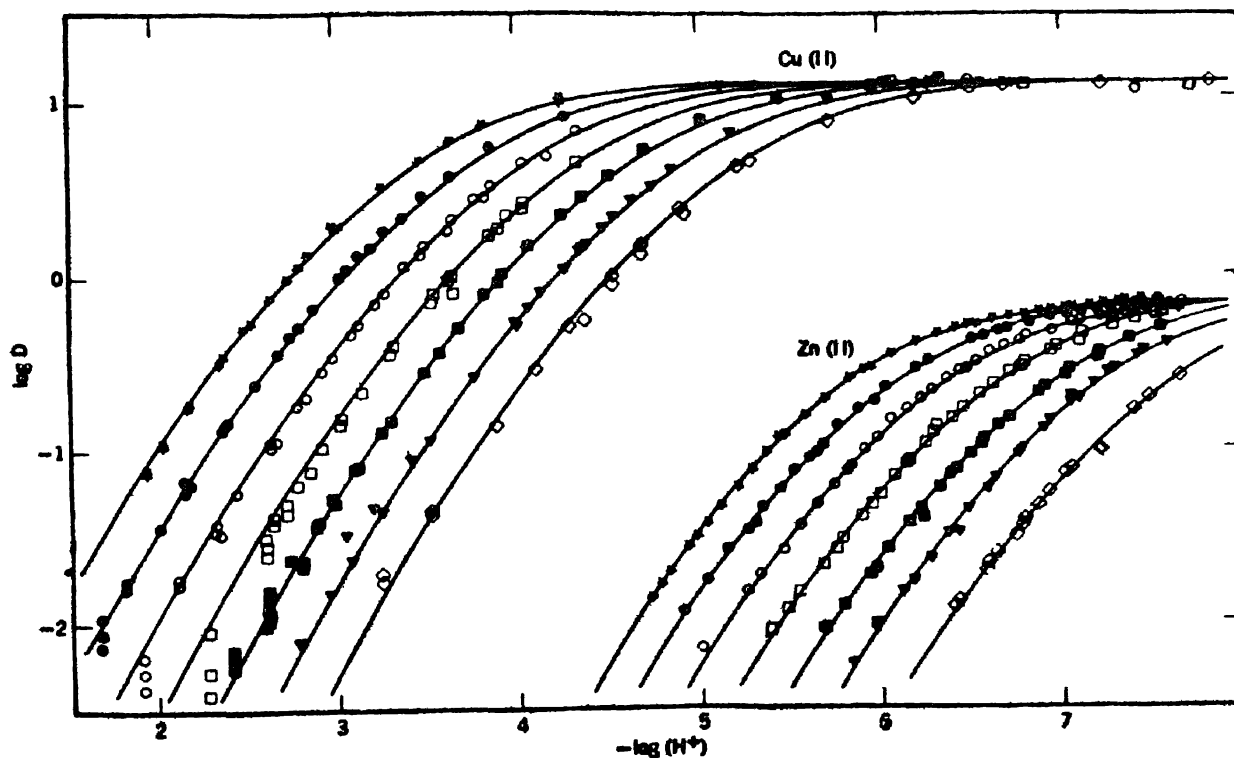

Fig. 1. The distribution  $D$  of Cu(II) and Zn(II) between benzene and 1M NaClO<sub>4</sub> as a function of hydrogen ion and acetylacetonate concentration at 25°C.

	Cu(II)	Zn(II)		Cu(II)	Zn(II)		Cu(II)	Zn(II)		Cu(II)	Zn(II)
(★) $[HAA]_{aq} = 46.2mM$		80.0mM	(O)	12.5	22.3	(■)	3.3	5.8	(◁)	0.9	1.7
(●)	24.3	42.9	(□)	6.4	11.4	(▼)	1.7	2.9			

the total heat change. Thus this particular technique enables us to selectively study  $\lambda_z$  (T). It should be clear from this discussion that it is not necessary to know the  $\beta_n$ -values or their temperature dependence, in order to determine  $\Delta H$  and  $\Delta S$  for reaction I. The approach to and achievement of the plateau requires some experimental work; this is much facilitated by the AKUFVE-technique.

For our purpose, a somewhat more accurate treatment of the distribution equilibrium must be made, where the activities are considered: The solute  $ML_z$  must be in equilibrium with the same gas-phase regardless of whether it is dissolved in water or in organic solvents. Thus we can write that

$$P_{ML_z}(g) = \kappa_{org} \{ML_z\}_{org} \quad (6a)$$

$$P_{ML_z}(g) = \kappa_{aq} \{ML_z\}_{aq} \quad (6b)$$

where  $\kappa_{org}$  and  $\kappa_{aq}$  are two constants, and  $\{ \}$  indicates activity. Using the assumption of equal partial pressure we can combine these equations, which gives the relation

$$[ML_z]_{org}/[ML_z]_{aq} = \kappa_{aq}/\kappa_{org} = \text{const.} \quad (7)$$

By choosing an infinitely dilute solution as our standard state, we can assume that Henry's law will hold at the standard state, and we can define the activity factors as

$$f_{org} = \{ML_z\}_{org} / [ML_z]_{org} \quad (8a)$$

$$f_{aq} = \{ML_z\}_{aq} / [ML_z]_{aq} \quad (8b)$$

Thus we obtain the following relation between the activity coefficients and our measured  $\lambda_z$

$$\lambda_z = \frac{[ML_z]_{org}}{[ML_z]_{aq}} = \frac{\{ML_z\}_{org}}{\{ML_z\}_{aq}} \cdot \frac{f_{aq}}{f_{org}} = \frac{\kappa_{aq}}{\kappa_{org}} \cdot \frac{f_{aq}}{f_{org}} \quad (9)$$

From this equation it is clear that variations in  $\lambda_z$  for a given solvent pair must be caused by variations in the ratio between the activity coefficients. It is obvious that we never can determine  $f_{aq}$  or  $f_{org}$  separately from distribution experiments. Still we want to compare  $f_{org}$  for different solvents. We can then make the arbitrary decision that  $f_{org}$  is equal 1 in n-hexane, as we expect very little interaction between  $ML_z$  and this solvent, and  $f_{aq}$  can also be assumed as 1 in very dilute aqueous solutions. Thus we may compute the constant  $\kappa_{aq}/\kappa_{n\text{-hexane}}$ . We may then assume  $\kappa_{aq}/\kappa_{org} = \kappa_{aq}/\kappa_{n\text{-hexane}}$  in all 'ideal' organic solvents, i.e. in all n-hexane-like solvents. Table 2 shows values of our standard activity factors for several solvents and metal acetyl-

acetates. These values can be correlated to the difference in solubility parameters between  $ML_z$  and solvent, as is discussed in section 5.

### Species in the two phases

We shall assume that the aqueous neutral metal complex is coordinatively saturated, assuming a maximum coordination number of C, and in addition hereto surrounded by a sheet of orientated water molecules. These outer molecules may be considered as being in a second coordination sphere, although they should not be regarded as what is usually called outer-sphere complexes. We will indicate this fully coordinated solvate by the symbol  $ML_zB_t[Aq]$ , where B may be water, or any kind of neutral adduct filling the inner coordination sphere. Under all circumstances the orientation of water around the mainly organic surface of the metal complex, probably increases the water-water interaction ('hydrophobic bonding') and must be taken into account in the thermodynamic studies. If L is monodentate and  $B=H_2O$ , then  $z+t < C$ ; for bidentate ligands (most of our cases) one has  $C > 2z+t$ .

The corresponding species in the organic phase is  $ML_zB_t[Org]$ , where Org represents molecules of the organic bulk phase (the solvent or diluent). B may be  $H_2O$ , Org or HL. With non-polar solvents without ability to form hydrogen bonds, it is reasonable to neglect [Org]. Doing this, the distribution equilibrium studied is

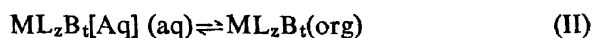

Our metal acetylacetonate complex ( $CuAA_2$ ,  $ZnAA_2$ ,  $CoAA_3$ ,  $ThAA_4$  and  $NpAA_4$ ) shall all be assumed to be coordinatively saturated, the coordination numbers being 4, 4, 6, 8 and 8, respectively, according to available data.  $AA^-$  is here bidentate. For the  $CuAA_2$  and  $ZnAA_2$  complexes this is a little bit doubtful, because both exhibit sometimes a coordination number of 5, or even 6, with regard to some ligands.<sup>11</sup> We will tentatively assume that the distribution reaction taking place in our system is approximately well described by

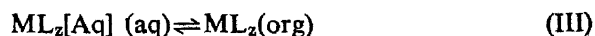

The reaction may occur in two steps:

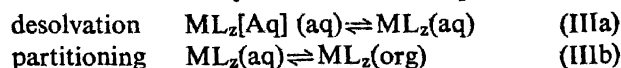

The desolvation involves a breaking down of the aqueous solvation sphere (the hydrophobic bonding) around the complex before it crosses the interface. If the metal complex also contains coordinated water,

$ML_z(H_2O)_i[Aq]$ , the coordinated water may or may not (dehydration in the later case) accompany the complex into the organic phase

On purpose we have been vague about what happens in the organic phase, partly because this is what we want to learn about, and we do not want to be prejudiced. However, it also leaves open an interesting possibility. Assume in reaction IIIb that  $ML_z$  is coordinatively unsaturated. When it enters the organic phase it meets a new, much less polar world, which, however, also invites to new interactions. The geometrical structure may then undergo a change as a consequence of this. It is known for example that the actinide(IV) tetra-acetylacetonates form two solid 8-coordinated structures. The energy difference between these structures is very small, and of the same order of magnitude as van der Waals interaction<sup>12</sup>. Different structures are crystallized out of different solvents, clearly indicating a solvent influence on the structure<sup>13</sup>. The same seems to be the case for  $CuAA_2$  and  $ZnAA_2$ <sup>11</sup>.

One may question to what extent it is possible to distinguish between the two steps in reaction III. Definitely, the ionic strength in the aqueous phase must be involved in reaction IIIa. The importance of reaction IIIa should also come out from a variation of the size of the complex, because the orientated water sheet must be proportional to the surface area of the complex. A volume effect will appear in reaction IIIb, because the solubility is considered to be related to the molar volume of the complex, as will be discussed in section 5. A variation of organic solvent can only influence reaction IIIb, at least as long as its solubility in the aqueous phase can be neglected. By a proper choice of experiments it may be possible to attribute the observed effects to a particular type of reaction.

### Born-Haber cycle for solvent extraction

Using the model outlined above, we can design a Born-Haber cycle, which is useful for evaluating  $\Delta H$  (and  $\Delta S$ ) for the distribution equilibrium.

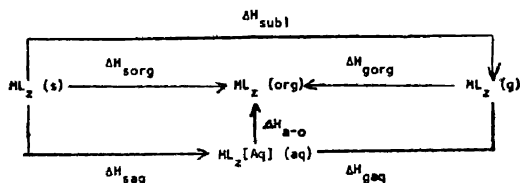

$$\text{Obviously } -\Delta H_{a-o} = \Delta H_{sorg} + \Delta H_{saq} \quad (10a)$$

$$= -\Delta H_{gorg} + \Delta H_{gaq} \quad (10b)$$

$$\Delta H_{subl} = \Delta H_{gorg} + \Delta H_{sorg} \quad (11a)$$

$$= \Delta H_{gaq} + \Delta H_{saq} \quad (11b)$$

The cycle contains 6 unknowns. However, from the heat of solutions,  $\Delta H_{sorg}$  and  $\Delta H_{saq}$ , the parameter we are primarily interested in,  $\Delta H_{a-o}$ , is obtainable from eqn 10a; the lattice energy involved (which is equal to  $\Delta H_{subl}$ ) cancels in the equation. The other relations are of interest as a crosscheck if  $ML_z$  is stable in the gas phase, this is the case for many metal acetylacetonates, which have appreciable vapor pressures already at moderate temperatures<sup>11</sup>.

This will not alleviate the need for independent  $\Delta H_{a-o}$  determinations from liquid-liquid distribution data, one reason being the need for good  $\Delta S$ -values. Further if the heat of solution is studied calorimetrically with 'dry' solvents, the influence of dissolved organic in water, and vice versa, in the liquid-liquid distribution experiments will show up by comparison. Other effects, which have been overlooked may also show up. Finally, as pointed out before, many of the metal complexes are sparingly soluble in organic solvents and water, thus making it difficult to accurately determine  $\Delta H_{saq}$  and  $\Delta H_{sorg}$  calorimetrically. Of the two steps, reaction IIIa, is expected to be accompanied by a large (positive) entropy change but not reaction IIIb, except for the entropy of dilution.

### Thermodynamics of the distribution equilibria

$$\text{From thermodynamics one has} \\ -RT \ln 10 \log \lambda_z = \Delta H - T \Delta S \quad (12)$$

where the enthalpy and entropy changes refer to reaction 1. Applying the theory of regular solutions,<sup>6</sup> one finds for dilute solutions of mixtures of low miscibility<sup>7a, b</sup> that

$$\Delta S = \Delta S_{reg} = -R \cdot V_z (V_{org}^{-1} - V_{aq}^{-1}) \quad (13)$$

and

$$\Delta H = \Delta H_{reg} = V_z (\delta_{aq} + \delta_{org} - 2\delta_z) \\ (\delta_{aq} - \delta_{org}) \quad (14a)$$

or

$$\Delta H = \Delta H_{reg} = V_z [(\delta_z - \delta_{aq})^2 \\ - (\delta_z - \delta_{org})^2] \quad (14b)$$

where  $V$  is the molar volume, and  $\delta$  the solubility parameter of the metal complex, the aqueous and organic solvent molecules (index  $z$ ,  $aq$  and  $org$ , respectively). The solubility parameter is defined as square root of the specific cohesion energy,  $\Delta E_v/V$  where  $E_v$  is the heat of evaporation at constant volume. These relations indicate that  $\lambda_z$  may be calculated from known values of  $V$  and  $\delta$ , such

values are readily available.<sup>6, 14, 15</sup> However, the expressions (13) and (14) are based on a number of approximations :

The entropy of mixing is ideal : When a solute dissolves (expands) into the solvent it is assumed to become randomly distributed, and not enter into any ordered interchange with the solvent molecules. This leads to the entropy increase in eqn. (13). This simple situation does not hold for all solutes and solvents, and particularly not for the aqueous phase, (cf. species in the two phases) which itself is ordered.<sup>16</sup> Thus it may be reasonable to add an excess entropy term  $\Delta S_{\text{exc}}$ , so that

$$\Delta S = \Delta S_{\text{obs}} = \Delta S_{\text{reg}} + \Delta S_{\text{exc}} \quad (15)$$

This relation is of interest when observed  $\Delta S$ -values are available.

It has become practice to compare  $\lambda_z$  -values, with one solvent as a reference, and from such comparisons calculate  $\delta$  values. Under such conditions combining eqns. (12), (13) and (14b)<sup>7a</sup>

$$RT \ln \frac{\lambda_z}{\lambda_z^I} = V_z [ (\delta_z - \delta_{\text{org}}^I)^2 - (\delta_z - \delta_{\text{org}})^2 ] + \frac{RT}{V_z} \left( \frac{1}{V_{\text{org}}} - \frac{2}{V_{\text{org}}^I} \right) \quad (16)$$

where prime values refer to the reference solvent. Siekiński used this expression to calculate  $\delta$  values for germanium tetrahalides from measurements of distribution between 18 organic solvents and water. A similar approach by Wakabayashi et al.<sup>7b</sup> was used for the distribution of  $\beta$ -diketones. Extending this comparison to metal chelates and chelating agents (HL) Omori et al.<sup>7b</sup> derived the relation

$$\log \lambda_z = \frac{V_z}{V_{\text{HL}}} \log k_d + \text{const.} \quad (17)$$

For  $\text{ScAA}_3$  a plot of  $\log \lambda_3$  against  $\log k_d$  gave a slope of 2.9 ( $=V_z/V_{\text{HL}}$ ) for 17 different organic solvents. Similarly, Liljenzin and Stary<sup>18</sup> obtained a slope of 4 for  $\text{NpAA}_4$  in 4 different solvents.

The solubility parameter concept uses the assumption that for each kind of molecule one single kind of internal property is responsible for all interactions of this molecule with its surroundings. However, it is well known, for example, that polar molecules may induce dipoles in molecules, between which only

dispersion forces exists. It has therefore been suggested that the solubility parameter should be expressed as a sum of different interactions :<sup>14</sup>

$$\delta^2 = \delta_{\text{dis}}^2 + \delta_{\text{pol}}^2 + \delta_{\text{hyd}}^2 \quad (18)$$

where  $\delta_{\text{dis}}$  refer to London dispersion interaction, dipole interaction and hydrogen bonding. Hanson<sup>14</sup> has shown that theoretical estimates of  $\delta_{\text{pol}}$  and  $\delta_{\text{hyd}}$  can be well correlated with experimental results. The concept has been found very useful for describing hundreds of systems.<sup>15</sup>

## Experimental technique

### 1. Chemicals

All chemicals have been of p.a. quality. For all metals so far investigated by us (Cu, Zn, Th and Np), radioactive tracers have been used, although the total metal (radioactive plus stable isotopes) concentration usually has been about  $10^{-4}$  M. At lower metal concentrations interfering phenomena begin to occur like surface adsorption, etc. The metal concentration has always been much lower than the total ligand concentration.

### 2. AKUFVE

Most distribution experiments have been carried out in a AKUFVE equipment, see Fig. 2.<sup>17</sup> In the AKUFVE the two phases are thoroughly contacted in the mixture, and then separated in the continuous liquid flow centrifuge. The phases leaving the centrifuge are very free from entrainments, usually better than 99.99 % pure.<sup>9</sup> These clean phases pass detectors for on-line measurements of the radioactive metals (sampling, and off-line measurements are occasionally used), glass electrodes, etc., and then, via heat-exchangers, back to the mixing chamber. The composition of the mixture is varied through additions of reagents to the mixing chamber. The temperature is varied through the heat exchangers, which are connected to thermostates. The temperature is measured in the mixing chamber ; the temperature in the whole system departs with  $<0.5^\circ$  from that of the mixing chamber.

The collected information (radioactivity of each phase, pH, temperature, etc.) is collected every minute on the data logger. The data logger is connected on-line to a Honeywell H-316 computer for direct plotting of the distribution ratio  $\log D$  against the

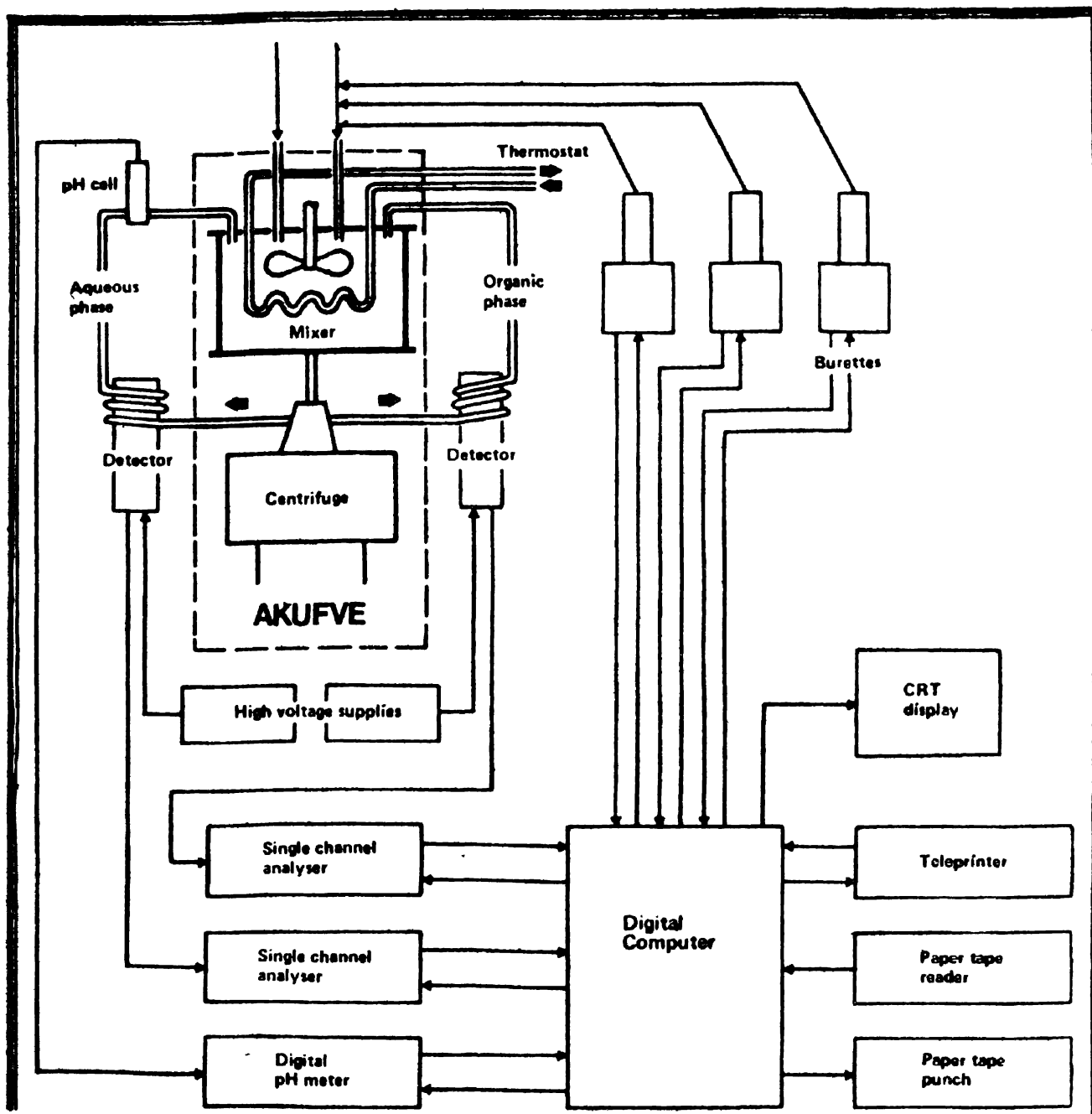

Fig. 2. Schematic diagram of the AKUFVE wet system (upper part) and connections for data treatment<sup>17</sup>.

variable of interest (ionic strength,  $pH$ ,  $\log [L^-]$ , temperature, etc.) on a display unit.

With this arrangement many hundred points can be collected, the data treated and the results plotted every day.

#### Effect of ionic strength

The distribution of  $ZnAA_2$  between benzene and water containing 0.1–2.6  $M NaClO_4$  was measured at different temperatures ( $10^\circ-45^\circ$ ). The composition of the organic phase varies slightly with the change

in aqueous ionic strength. It has been found by Johansson and Rydberg<sup>9a</sup> that  $k_d$  for acetylacetone goes from 5.8 to 4.8 when the  $\text{NaClO}_4$  concentration in the aqueous phase is increased from 0.1 to 1.0  $M$  (a 'salting-in' effect). However, this is not sufficient to account for the  $\log \lambda_z$  ( $\mu$ ) dependency. Further, the same authors found no temperature dependency of  $k_d$  for HAA, except for  $\text{CHCl}_3$ .

In table 1,  $\log \lambda_z$  is given as a function of  $[\text{NaClO}_4]$  at 25°. A plot of  $\log \lambda_z$  against  $[\text{NaClO}_4]$  gives a straight line; the scatter of points around this line slightly decreases when  $\log \lambda_z$  is plotted against concentration of 'free water',  $[\text{H}_2\text{O}]$ , assuming that each  $\text{NaClO}_4$  coordinates 4 water molecules,<sup>5,p.33</sup> see Fig. 3. Only 'free water' can form a hydrogen bonded sheet round the metal complex in the water phase. A decrease in available water will shift reaction IIIa to the right, leading to an increased  $\lambda_z$ -value as observed.

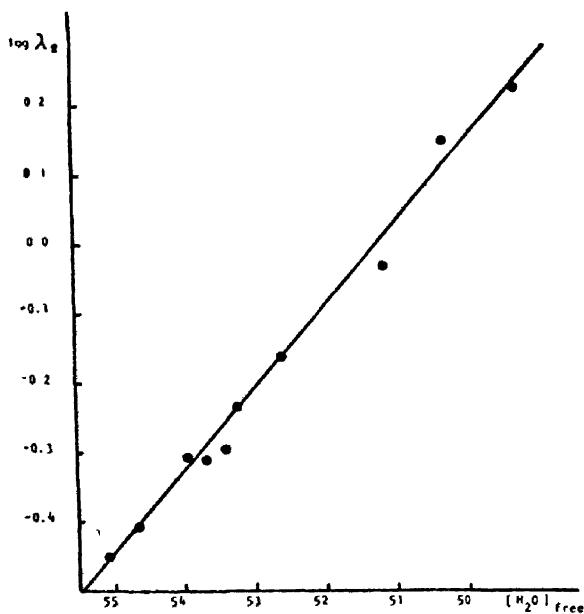

Fig. 3. Equilibrium constant ( $\lambda_z$ ) for the distribution of  $\text{ZnAA}_2$  between benzene (originally 0.25  $M$  in HAA, equal phase volumes) and  $\text{NaClO}_4$  as a function of calculated concentration of free water; 25°C.

Although  $\Delta H/T\Delta S$  varies regularly with  $[\text{NaClO}_4]$  (as a consequence of the change in  $\log \lambda_z$ ), see Table 1, the accuracy in the measurements are not good enough to unequivocally establish trends in  $\Delta H$  and  $\Delta S$ . The average thermodynamic values are  $\Delta H=49 \pm 2 \text{ kJ/mole}$  and  $T\Delta S=49 \pm 2 \text{ kJ/mole}$ ; the data only indicated that  $\Delta H$  changes less than  $\Delta S$ . It is interesting to note that the energy required to break

a water hydrogen bond is  $\Delta H \sim 10 \text{ kJ.mole}^{-1}$  and  $T\Delta S \sim 11 \text{ kJ.mole}^{-1}$ .<sup>16</sup>

TABLE 1—DISTRIBUTION CONSTANTS ( $\lambda_z$ ) AND ENTHALPY/ENTROPY ( $\Delta H/T\Delta S$ ) FOR THE PARTITION OF  $\text{ZnAA}_2$  BETWEEN BENZENE (originally being 0.25  $M$  in HAA) AND  $\text{NaClO}_4$ , AT 25°.

$[\text{NaClO}_4]_{\text{aq}}$	$\log \lambda_z$	$\Delta H/T\Delta S$
0.109	-0.450	1.050
0.306	-0.407	1.046
0.604	-0.310	1.036
0.805	-0.295	1.033
0.927	-0.232	1.027
1.000	-0.207	1.026
1.198	-0.160	1.019
1.926	-0.003	1.000
2.210	0.151	0.797
2.647	0.229	0.972

#### Influence of solvent

In table 2,  $\lambda_z$ -values are given for the extraction of  $\text{ZnAA}_2$  and  $\text{NpAA}_4$  from 1  $M$   $\text{NaClO}_4$  into different solvents. It is seen that  $\lambda_z$  does not vary regular either with the solubility parameter values (letter order a-i) or the dielectric strengths (figure order 1-10) of the organic solvents. This is also understandable, because the solvents belong to different classes, namely rather inert solvents only exhibiting dispersion forces (a, c and e), solvents which are basic and contain donor electrons (b, d and j), solvents which may interact through easily available  $\pi$ -electrons (f, g and h), and solvents which have an 'acid' hydrogen available for hydrogen bonding (i). In the table, the solvent have been grouped together accordingly. It is seen that the interaction parameter,  $\log f_{\text{org}}$ , in all groups increases with increasing solubility parameter  $\delta_{\text{org}}$ . This shows the importance of the solubility parameter concept, but also indicates a necessity for improvements, in which the different types of interactions are sorted out. Attempts to apply the three dimensional solubility parameter of Hansen<sup>14</sup> did not give a satisfactory explanation of the results in Table 2.



TABLE 2—APPARENT ACTIVITY FACTORS FOR ACETYLACETONATO-METAL COMPLEXES  $MAA_z$  IN DIFFERENT ORGANIC SOLVENTS, NORMALIZED TO  $f_{n\text{-hexane}}=1$ ; SEE EQUATION (9)

Solvent	dielectric constant $\epsilon$	Solubility parameter $\sigma_{\text{org}}$	ZnAA <sub>2</sub>		NpAA <sub>4</sub>	
			log $\lambda_z$	log $f_{\text{org}}$	log $\lambda_z$	log $f_{\text{org}}$
n-hexane	1.88 (1)	7.27 (a)	-1.276	0.0	0.537	0.0
cyclohexane	2.02 (2)	8.20 (c)	-1.162	0.114	0.812	0.275
carbontetrachloride	2.23 (3)	8.65 (e)	-0.388	0.888	2.68	2.14
dibutylether	3.08 (7)	7.6 (b)	-1.041	0.235		
hexone	13.11 (9)	8.57 (d)	-0.147	1.129	1.23	0.69
benzotrile	25.2 (10)	11.09 (j)	0.214	1.480		
xylene	2.57 (6)	8.80 (f)	-0.471	0.805		
toluene	2.38 (5)	8.91 (g)	-0.389	0.887		
benzene	2.23 (3)	9.16 (h)	-0.207	1.069	3.45	2.91
chloroform	4.81 (8)	9.57 (i)	0.834	2.110		

In Fig. 4 log  $\lambda_{\text{ZnAA}_2}$  is plotted against log  $k_d$  for HAA. All points are distributed around a straight line, as is expected from eqn. 17. From the slope  $V_z/V_{\text{HL}}$  equal to 1.52, one calculates the molar volume of ZnAA<sub>2</sub> to 156 with a value of 102 for HAA.<sup>7b</sup>

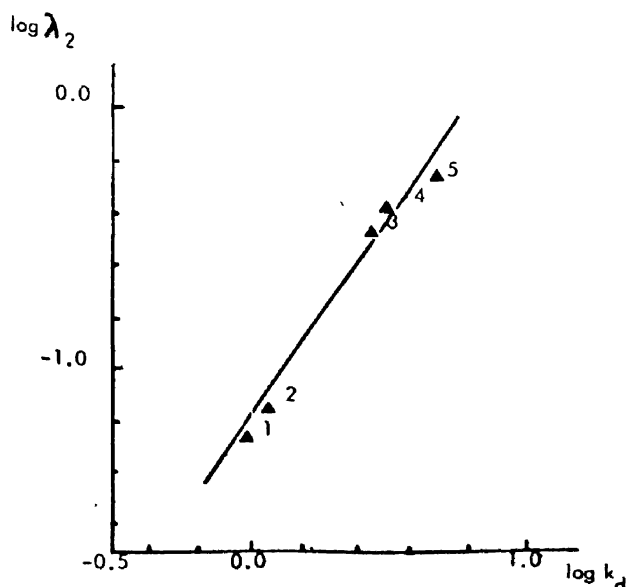

Fig. 4. Log  $\lambda_z$  (for ZnAA<sub>2</sub>) as a function of log  $k_d$  (for HAA) for various solvents and 1 M NaClO<sub>4</sub>. 1. n-hexane, 2. cyclohexane, 3. xylene, 4. Carbontetrachloride, and 5. benzene.

This is considerably lower than the value of 172 obtained by Mitchell and Banks<sup>7c</sup> for CuAA<sub>2</sub>. We have therefore also plotted log  $\lambda_{\text{CuAA}_2}$  against log  $k_d$  using our data in table 3. From that plot  $V_{\text{CuAA}_2}$  becomes 167, in good agreement with the value 172,<sup>7c</sup> although our extractions are carried out from 1 M NaClO<sub>4</sub> as compared to the 0.1 M acetate buffer used by Mitchell and Banks.

In Table 3,  $\Delta H$  and  $T\Delta S$  are given for the extraction of CuAA<sub>2</sub> and ZnAA<sub>2</sub>. These values are obtained from  $\lambda_z$  temperature dependency measurements, as indicated in Fig. 5. The deviations in  $\Delta H$  and  $T\Delta S$  are quite great within each group. A general tendency is that  $\Delta H \approx T\Delta S$ , except for CHCl<sub>3</sub>, and that  $T\Delta S$  is less for the solvent groups, which are expected to interact with the solute, i.e. for the electron-donor solvents and CHCl<sub>3</sub>. The interaction leads to a solvation of the solute; i.e. increased ordering and thus lower  $T\Delta S$ . While the decrease in  $T\Delta S$  leads to higher  $\lambda_z$ , the corresponding increase in  $\Delta H$  compensates in the other direction.

A calculation of  $\Delta H$  and  $T\Delta S$  with eqns. (13) and (14b) for the distribution of CuAA<sub>2</sub> between CCl<sub>4</sub> and water yields  $\Delta H$  45, and  $T\Delta S$  27 kJ.mole<sup>-1</sup>,

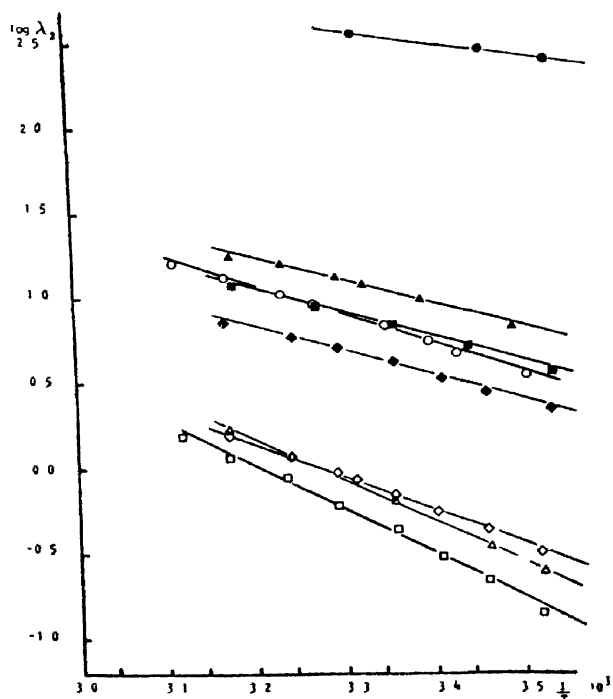

Fig. 5. Equilibrium constant ( $\lambda_2$ ) for the distribution of  $\text{CuAA}_2$  (filled symbols) and  $\text{ZnAA}_2$  (open symbols) between various organic solvents (originally 0.25 M in HAA ; equal phase volumes) and 1 M  $\text{NaClO}_4$  as a function of temperature. Chloroform  $\bullet$ , benzene  $\Delta$ , toluene  $\blacksquare$ , and methyl-isobutylketone  $\square$ .

TABLE 3—DISTRIBUTION CONSTANTS AND THERMODYNAMIC DATA FOR THE EXTRACTION OF  $\text{CuAA}_2$  AND  $\text{ZnAA}_2$  FROM 1 M  $\text{NaClO}_4$  INTO VARIOUS SOLVENTS, ORIGINALLY 0.25 M IN HAA (equal phase volumes) AT 25°.  $\Delta H$  AND  $T\Delta S$  IN  $\text{kJ}\cdot\text{mole}^{-1}$ .

Solvent	$\text{ZnAA}_2$			$\text{CuAA}_2$		
	$\log \lambda_2$	$\Delta H$	$T\Delta S$	$\log \lambda_2$	$\Delta H$	$T\Delta S$
n-hexane	-1.28	45	38			
cyclohexane	-1.16	55	48	-0.04	27	26
carbontetrachloride	-0.39	51	49	0.85	27	32
dibutylether	-1.04	51	45			
hexone	-0.15	37	36	0.62	28	32
benzonitrile	0.21	35	36			
xylene	-0.47	44	41			
toluene	-0.39	50	48	0.86	29	34
benzene	-0.21	47	46	1.04	26	32
chloroform	0.83	33	38	2.54	14	28

which shall be compared with the measured values 27 and 32, respectively.

Equations (14) and (16) have been used to calculate  $\delta_{\text{aq}}$  with reference to n-hexane. The large variations obtained in table 4 indicate that the approach is unsatisfactory. We are therefore considering alternative approaches to the problem.

#### Influence of structure on $\Delta H$ and $\Delta S$ .

Some thermodynamic constants are given in table 5 for the extraction of acetylacetone and metal acetylacetonates from 1 M  $\text{NaClO}_4$  into various solvents. It is noted that both  $\Delta H$  and  $\Delta S$  are positive for all metal complexes. Then  $\Delta H$  opposes the reaction (spontaneous for  $G < 0$ ), while  $\Delta S$  enhances the extraction out of the aqueous phase into the organic solvent. The data are too meager to make possible any further general conclusions. From the previous discussion (section 5) it should also be clear that the  $\Delta H$ -values may consist of three parts, one each for dispersion, dipole and hydrogen bonding interactions.

The large negative  $\Delta H$  for the extraction of acetylacetone into  $\text{CHCl}_3$  has been explained by Johansson and Rydberg<sup>9a</sup> as being due to a hydrogen bond formation between the solute and solvent.

$\text{CuAA}$  has basically a 4-coordinated planar structure with a slight tendency to coordinate another one or two molecules perpendicular to the plane, forming octahedron. Using eqn. 13 one finds  $T\Delta S$  about 19  $\text{kJ}\cdot\text{mole}^{-1}$  for the three solvents  $\text{CCl}_4$ ,  $\text{C}_6\text{H}_6$  and  $\text{CHCl}_3$ , which differs considerably from the observed values. The much smaller  $\Delta H$  for  $\text{CHCl}_3$ , as compared to the two other solvents, favours the extraction of  $\text{CuAA}_2$ . It seems reasonable to believe that the slightly acid  $\text{CHCl}_3$  interacts through its hydrogen with the partly exposed basic oxygens of the acetylacetone molecules. One may thus assume a mild solvation of  $\text{CHCl}_3$  to  $\text{CuAA}_2$  perpendicular to the coordination plane.

$\text{ZnAA}_2$  is reported to be tetrahedral in many solvents. However, it is also generally believed that in polar solvents  $\text{ZnAA}_2$  attains a 5-coordinated structure, while it may polymerize (probably to a trimer) in non-polar solvents. This influence of the solvent is reflected in the low  $\Delta H$  value in  $\text{CHCl}_3$  as compared to the less polar solvents. Using a molar volume of 156  $\text{cm}^3$  one obtains  $T\Delta S$  about 18  $\text{kJ}\cdot\text{mole}^{-1}$  for all 4 solvents. Subtracting this

TABLE 4—CALCULATED SOLUBILITY PARAMETERS FOR WATER,  $\delta_{aq}$  USING DIFFERENT ORGANIC SOLVENTS AS REFERENCE AND VOLUME OF 142 CM<sup>3</sup> FOR ZnAA<sub>2</sub>

Organic phase	Solubility parameter		Organic phase	Solubility parameter			
	$\delta_{org}$	$\delta_{aq}$ (calc.)		$\delta_{org}$	$\delta_{aq}$ (calc.)		
(a) n-Hexane	(a)	7.27	ref.	(d) Hexone	(e)	8.65	354.42
	(b)	7.6	15.02		(f)	8.9	47.14
	(c)	8.2	12.15		(g)	8.91	21.31
	(d)	9.58	16.63		(h)	9.16	21.08
	(e)	8.65	18.33		(i)	9.57	39.02
	(f)	8.9	19.76		(j)	11.09	21.70
	(g)	8.91	17.72	(e) Carbontetrachloride	(f)	8.9	7.22
	(h)	9.16	19.01		(g)	8.91	7.88
	(i)	9.57	19.98		(h)	9.16	6.31
	(j)	11.09	20.14		(i)	9.57	19.66
(b) Dibutylether	(c)	8.2	10.13		(j)	11.09	18.28
	(d)	8.58	17.18	(f) Toluene	(g)	8.91	8.83
	(e)	8.65	26.96		(h)	9.16	6.87
	(f)	8.9	20.56		(i)	9.57	35.14
	(g)	8.91	18.40		(j)	11.09	20.71
	(h)	9.16	19.76	(g) Xylene	(h)	9.16	30.13
	(i)	9.57	18.79		(i)	9.57	51.45
(c) Cyclohexane	(j)	11.09	20.62		(j)	11.09	21.79
	(d)	8.58	21.30	(h) Benzene	(i)	9.57	63.54
	(e)	8.65	74.92		(j)	11.09	21.55
	(f)	8.9	32.48	(i) Chloroform	(j)	11.09	16.41
	(g)	8.91	21.80	(j) Benzonitril			
	(h)	9.16	21.17				
	(i)	9.57	33.83				
	(j)	11.09	21.75				

value from those in table 5 gives a  $T\Delta S_{exc}$  of 20, 31, 31 and 20 for the four solvents, respectively. This difference may be attributed to structural ordering in the organic phase, around the zinc complex. However, more data are needed before more definitive conclusions can be drawn.

The considerable difference between the CuAA<sub>2</sub> complexes can be due to the planar structure of the CuAA<sub>2</sub>, which invites coordination with the solvent more than the tetrahedral ZnAA<sub>2</sub>; thus a lower  $\Delta H$  for the CuAA<sub>2</sub> extraction. However, this is contradictory to the results for CoAA<sub>3</sub>, which has

TABLE 5—DISTRIBUTION CONSTANTS ( $k_d$  for HAA and  $\lambda_2$  for  $ML_2$ ) AND CORRESPONDING THERMODYNAMIC CONSTANTS FOR THE DISTRIBUTION OF GIVEN SOLUTE BETWEEN DIFFERENT SOLVENTS AND 1 M  $NaClO_4$ .  $\Delta H$  AND  $T\Delta S$  ARE GIVEN IN  $KJ. MOLE^{-1}$ , 25°.

Solvent		n-hexane	carbontetrachloride	benzene	chloroform
dielectric const.		1.88	2.23	2.28	4.80
polarizability $\times 10^{24}$		11.9	10.6	10.4	8.5
solubility parameter		7.27	8.65	9.16	9.57
<hr/>					
HAA, $k_d$		0.9	2.9	4.6	23
CuAA <sub>2</sub> , $\lambda_2$			7.1	10.9	350
ZnAA <sub>2</sub> , $\lambda_2$		0.05	0.41	0.62	6.82
CoAA <sub>3</sub> , $\lambda_3$			34	109	
ThAA <sub>4</sub> , $\lambda_4$		25		315	350
NpAA <sub>4</sub> , $\lambda_4$		3.4		2800	
<hr/>					
HAA	$\Delta H$		0	0	-11
	$T\Delta S$			2.7	4.5
<hr/>					
CuAA <sub>2</sub>	$\Delta H$		27	26	14
	$T\Delta S$			32	32
<hr/>					
ZnAA <sub>2</sub>	$\Delta H$	45	51	49	33
	$T\Delta S$	38		49	49
<hr/>					
CoAA <sub>3</sub> (ref. 20)	$\Delta H$		27	23	
	$T\Delta S$			11	11
<hr/>					
ThAA <sub>4</sub>	$\Delta H$	79			
	$T\Delta S$		83		
<hr/>					
NpAA <sub>4</sub>	$\Delta H$	72			
	$T\Delta S$		75		

an octahedral structure, and thus is more similar to ZnAA<sub>2</sub> than to CuAA<sub>2</sub>. An important point may be that ZnAA<sub>2</sub> is less coordinatively saturated than CuAA<sub>2</sub> and CoAA<sub>2</sub>. In the water it probably forms a monohydrate, and the large  $\Delta H$  for the extraction may be caused by the energy required for dehydration. This would also lead to a larger  $T\Delta S$  value.

The actinide tetra-acetylacetonates exhibit much larger  $\Delta H$  and  $T\Delta S$  values than the other metal

complexes. This may partly be due to their larger molar volumes, which is 408 cm<sup>3</sup> for NpAA<sub>4</sub>,<sup>18</sup> and probably even larger for ThAA<sub>4</sub>.<sup>19</sup> From eqn. 13 a  $T\Delta S$  value of 48 kJ.mole<sup>-1</sup> is calculated for NpAA<sub>4</sub>.

#### Acknowledgement

The author is indebted to this helpful co-workers civ. ing. B. Allard, dr. S. Andersson, fil. kand. S. Johnsson and doc. J. O. Liljenzin.

References

1. See ref. in S. AHRLAND, J. O. LILJENZIN and J. RYDBERG, *Comprehensive Inorganic Chemistry* (Eds. J. C. Bailar, et al.) Vol. 5, p. 545, Pergamon Press 1973.
2. J. RYDBERG, *Modern Kemi* 1971, nr. 4.
3. *Eng. Min. J.* 1973, July, p. 21.
4. (a) A. AUE, L. SKJUTARE, G. BJORLING, H. REINHARDT and J. RYDBERG, *Proc. Int. Solv. Extr. Conf. Soc. Chem. Ind.*, London, 1971, p. 447.
- (b) J. RYDBERG, H. REINHARDT, B. LUNDEN and P. HAGLUND, *Int. Symp. Hydrometallurgy* (Eds. D. J. I. Evens and R. S. Shoemaker), Am. Int. Mining, Metall. Petr. Eng., New York 1973.
- (c) A. FLETCHER, *Chem. Ind.* 1973, May, p. 414.
5. Y. MARCUS and S. KERTES, *Ion Exchange and Solvent Extraction*, Wiley-Interscience 1969.
6. J. H. HILDEBRAND and R. L. SCOTT, *The Solubility of Nonelectrolytes*, New York 1950.
7. (a) S. SIEKIERSKI, *J. Inorg. Nuclear Chem.* 1962, **24**, 205 ; *ibid.*, 1963, **25**, 1351.
- (b) T. WAKAHAYASHI, S. OKI, T. OMORI and N. SUZUKI, *J. Inorg. Nuclear Chem.*, 1964, **26**, 2255 ; T. Omori, *et. al. ibid.*, p. 2265 ; S. Oki, *et. al. ibid.*, 1965, **27**, 1141.
- (c) J. W. MITCHELL and C. V. BANKS, *J. Inorg. Nuclear Chem.* 1969, **31**, 2105.
8. Cf. R. TREYBAL, *Liquid Extraction*, 2. ed., McGraw Hill Book Co., New York 1963.
9. (a) J. RYDBERG. *Acta Chem. Scand.*, 1969, **23**, 1947 ; H. REINHARDT and J. RYDBERG, *ibid.* 2773 ; C. ANDERSSON, S. O. ANDERSSON, J. O. LILJENZIN, H. REINHARDT and J. RYDBERG, *ibid.*, 2781 ; H. JOHANSSON and J. RYDBERG, *ibid.*, 2797.
- (b) J. RYDBERG, H. REINHARDT and J. O. LILJENZIN, *Ion Exchange and Solvent Extraction* (Eds. J. A. Marinsky and Y. Marcus) Vol. 3, p. 111, Marcel Dekker Inc., New York 1973.
10. E.g. (a) F. V. C. ROSSOTTI and H. ROSSOTTI, *The Determination of Stability Constants*, McGraw Hill Book Co., New York 1961.
- (b) M. T. BECK, *Chemistry of Complex Equilibria*, Van Nostrand, London 1970.
11. D. P. GRADDON, *Coord. Chem. Rev.*, 1969, **4**, 1.
12. J. L. HOARD and J. V. SILVERTON, *Inorg. Chem.*, 1963, **2**, 235 and 243.
13. B. ALLARD, *Acta Chem. Scand.*, 1972, **26**, 3492.
14. (a) C. HANSEN and K. SKAAUP, *Dansk kemi* 1967, **48**, 81.
- (b) C. M. HANSEN, *Ind. Eng. Chem. Res. Dev.* 1969, **8**, 2.
15. J. H. MEYER ZY BEXTER, *Farbe und Lack*, 1972, **73**, 813.
16. G. E. WALRAFEN, in *Hydrogen-Bonded Solvent Systems*, (Eds. A. K. Covington and P. Jones), Taylor and Francis Ltd., London 1968, p. 9.
17. (a) J. O. LILJENZIN, *Kem. tidskr.*, 1970, **7**, 14
- (b) S. A. ANDERSSON and D. R. SPINK, *Can Res. Dev.*, 1971, Nov./Dec. 16.
18. J. O. LILJENZIN and J. STARY, *J. Inorg. Nuclear Chem.* 1970, **32**, 1357.
19. B. ALLARD, 8, Nordic Structural Chem. Meeting, Bergen 1973.
20. P. D. HOPKINS and B. E. DOUGLAS, *Inorg. Chem.*, 1964, **3**, 357.