

See discussions, stats, and author profiles for this publication at: <https://www.researchgate.net/publication/358769340>

MDIW-13: New Database and Benchmark for Script Identification

Article in *Multimedia Tools and Applications* · February 2022

CITATIONS

0

READS

43

6 authors, including:



Miguel A. Ferrer

Universidad de Las Palmas de Gran Canaria

304 PUBLICATIONS 4,047 CITATIONS

[SEE PROFILE](#)



Abhijit Das

Thapar University

63 PUBLICATIONS 603 CITATIONS

[SEE PROFILE](#)



Moises Diaz

Universidad de Las Palmas de Gran Canaria

98 PUBLICATIONS 1,423 CITATIONS

[SEE PROFILE](#)



Aythami Morales

Universidad Autónoma de Madrid

200 PUBLICATIONS 2,531 CITATIONS

[SEE PROFILE](#)

Some of the authors of this publication are also working on these related projects:



Application of the Lognormal Model to the Vocal Tract Movement [View project](#)



sclera biometrics [View project](#)

[Click here to view linked References](#)

MDIW-13: New Database and Benchmark for Script Identification

Miguel A. Ferrer¹, Abhijit Das², Moises Diaz³, Aythami Morales⁴,
Cristina Carmona-Duarte⁵, Umapada Pal⁶

¹Instituto Universitario para el Desarrollo Tecnológico y la Innovación en Comunicaciones,
Universidad de Las Palmas de Gran Canaria, Campus de Tafira, Las Palmas de Gran Canaria, Spain,
ORCID number: 0000-0002-2924-1225, email: miguelangel.ferrer@ulpgc.es,

²Griffith University, Gold Coast, Queensland, Australia and Information Sciences institute,
University of Southern California, USA, ORCID number: 0000-0002-6793-0582, email:
abhijit.das@griffithuni.edu.au

³Instituto Universitario para el Desarrollo Tecnológico y la Innovación en Comunicaciones,
Universidad de Las Palmas de Gran Canaria, Campus de Tafira, Las Palmas de Gran Canaria, Spain,
ORCID number: 0000-0003-3878-3867, email: moises.diaz@ulpgc.es

⁴Universidad Autonoma de Madrid, Spain, ORCID number: 0000-0002-7268-478, email:
aythami.morales@uam.es

⁵Instituto Universitario para el Desarrollo Tecnológico y la Innovación en Comunicaciones,
Universidad de Las Palmas de Gran Canaria, Campus de Tafira, Las Palmas de Gran Canaria, Spain,
ORCID number: 0000-0002-4441-6652, email: cristina.carmona@ulpgc.es

⁶Computer Vision and Pattern Recognition Unit, Indian Statistical Institute, Kolkata, India, ORCID
number: 0000-0002-5426-2618, email: umapada@isical.ac.in

Corresponding author: Miguel A. Ferrer (e-mail: miguelangel.ferrer@ulpgc.es)

ABSTRACT

Script identification is a necessary step in some applications involving document analysis in a multi-script and multi-language environment. This paper provides a new database for benchmarking script identification algorithms, which contains both printed and handwritten documents collected from a wide variety of scripts, such as Arabic, Bengali (Bangla), Gujarati, Gurmukhi, Devanagari, Japanese, Kannada, Malayalam, Oriya, Roman, Tamil, Telugu, and Thai. The dataset consists of 1,135 documents scanned from local newspapers and handwritten letters and notes from different native writers. Further, these documents are segmented into lines and words, comprising a total of 13,979 and 86,655 lines and words, respectively, in the dataset. Easy-to-go benchmarks are proposed with handcrafted and deep learning methods. The benchmark includes results at the document, line, and word levels with printed and handwritten documents. Results of script identification independent of the document/line/word level and independent of the printed/handwritten letters are also given.

KEYWORDS: Document analysis, script identification, optical character recognition, handcrafted features for script identification, deep learning for script identification, Multi-script database.

DECLARATIONS

Funding: This study was funded by the Spanish government's PID2019-109099RB-C41 research project and European Union FEDER program/funds.

Conflicts of interest/Competing interests: Not applicable

Availability of data and material: A database. The full database will be freely available after the acceptance of the manuscript. Samples of the database (roughly 5% of the database) are available at: [Database Sample](#)

Code availability: Not applicable

Authors' contributions: Miguel A. Ferrer: Database preprocessing, script identification based on LBP features and wrote the paper with input from all authors, Abhijit Das: Database collection, preprocessing and script identification based on dense multi-block LBP features, Moises Diaz: Database preprocessing and script identification based on Quad-Tree Histogram templates, Aythami Morales: script identification based on deep learning, Cristina Carmona-Duarte: database preprocessing, Umapada Pal: Conceived of the presented idea and database collection. All authors discussed the results and contributed to the final manuscript.

1. INTRODUCTION

With the ever-increasing demand for the creation of a digital world, many Optical Character Recognition (OCR) algorithms have been developed over the years. A script can be defined as the graphic form of the writing system used to write a statement. The availability of large numbers of scripts makes the development of a universal OCR a challenging task. This is because the features needed for character recognition are usually a function of structural script properties and the number of possible classes or characters. The extremely high number of available scripts makes the task quite daunting, and as a result, most OCR systems are script-dependent [1].

The approach for handling documents in a multi-script environment is divided into two steps: first, the script of the document, block, line, or word is estimated, and secondly, the appropriate OCR is used. This approach requires a script identifier and a bank of OCRs, at a rate of one OCR per possible script.

Many script identification algorithms have been proposed in the literature. A survey published in 2010 with a taxonomy of script identification systems can be found in [2]. A more recent global study on state-of-the-art script identification can be found in [3]. Instead, the survey in [4] is focused on Indic Scripts. These surveys report novel performances of script identification methods based on pattern recognition strategies.

Script identification can be conducted either offline, from scanned documents, or online if the writing sequence is available. Identification can also be classified either as *printed* or *handwritten*, with the latter being the more challenging. Script identification can be performed at different levels: page or document, paragraph, block, line, word, and character. An example for Indic scripts is given in [5].

As it is similar to any classical classification problem, the script identification problem is a function of the number of possible classes or scripts to be detected. Furthermore, any similarity in the structure of scripts represents an added challenge. If two or more scripts are very similar, then the identification complexity increases. For example, the Kannada and Telugu scripts are very similar and thus, lend themselves to confusion in many cases. Although documents with two scripts represent the most common problem, documents with three and more scripts can also be found [6].

A unified approach based on local patterns analysis was proposed in [7] for script identification at line level and improved in [8] for word level. It was applied to video frames in

1
2
3
4
5 [9]. In these cases, histograms of local patterns are used as features describing both the direction
6 distribution and global appearance of strokes. In a further step, Neural Networks have
7 demonstrated their capacity to extract highly discriminant features from images when enough
8 data is available. Consequently, Neural Networks with Deep Learning have been explored in
9 many tasks that involve document analysis. Specifically, in [10], the authors proposed a
10 Discriminative Convolutional Neural Network (DCNN). Their approach combines deep
11 features obtained from three convolutional layers. Their results, which registered performance
12 gains of over 90% in a database with 13 scripts, demonstrate the feature extraction capacity of
13 DCNN for script identification tasks.

14
15 Other approaches have explored similar or optimized architectures like Discriminative CNN
16 [10]. An example is given in [11], where the authors stated that addressing the script
17 identification problem with state-of-the-art Convolutional Neural Network (CNN) classifiers is
18 not straightforward, as they fail to address some key characteristics of scripts, e.g., their
19 extremely variable aspect ratio. Instead of resizing input images to a fixed aspect ratio, the
20 authors of [11] proposed a patch-based classification framework to preserve discriminative
21 parts of the image. To this end, they used ensembles of conjoined networks to jointly learn
22 discriminative stroke-part representations and their relative importance in a patch-based
23 classification scheme.

24
25 CNNs have further been applied to handwritten script recognition, as proposed in [12]. In that
26 work, an architecture composed of two convolutional layers was employed. The results in a
27 database containing 5 scripts demonstrate the potential of CNNs in either handwritten or printed
28 text. Recurrent Neural Networks (e.g., Long Short-Term Memory Networks) have been
29 explored in the context of Arabic [13] and Indic [14] script identification. These network
30 architectures allow capturing sequential information and achieving state-of-the-art
31 performance. Also, a combination of individually trainable small CNNs with modifications in
32 their architectures was used in [15] for multi-script identification.

33
34 Further, the authors in [16] introduced the extreme learning machine (ELM) technique, which
35 generalizes the performance of neural networks. The authors studied this technique on 11
36 official Indic scripts and observed significant results when the sigmoidal activation function
37 was used.

38
39 The power of CNN was also evidenced in [12] to identify Chinese, English, Japanese,
40 Korean, or Russian scripts. The authors also evaluated whether the texts were handwritten or
41 machine-printed and obtained excellent performances.

42
43 In summary, while most works claim identification rates exceeding 92%, each work,
44 however, uses different datasets with different script combinations. Therefore, it is difficult to
45 carry out a fair comparison of these different approaches. Moreover, the databases employed
46 in related studies usually include two to four scripts. A few actually include an even higher
47 number of scripts. The most popular scripts are Latin, Indian, Japanese and Chinese, with
48 Greek, Russian and Hebrew also featuring here and there [2]. A common database allowing a
49 fair comparison of different algorithms would thus be desirable.

50
51 While building a dataset used to be a costly endeavor, it has become much simpler and easier
52 today, even though the task remains arduous and laborious. For instance, documents from
53 different scripts can be generated using the Google Translate application, as in [8], for example.
54 However, in this case, the font, size and background of the generated document will be the
55 same, which is unrealistic.

56
57
58
59
60
61
62
63
64
65



Fig 1. Samples of newspapers used for the dataset

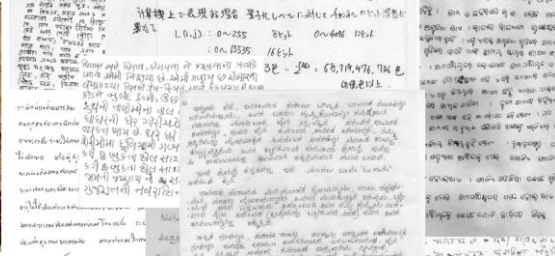

Fig 2. Samples of handwritten documents used for the dataset

To alleviate this drawback, this paper aims to offer a database for script identification, which consists of a wide variety of some of the most commonly used scripts, collected from real-life printed and handwritten documents. Further, along with the database, its benchmarking with texture-based features and deep learning are also showcased. The printed documents in the database were obtained from local newspapers and magazines, and therefore, comprise different fonts and sizes and cursive and bold text. A sample of the newspapers used can be seen in Fig 1. The handwritten part was obtained from volunteers from all over the world, who scanned and shared their manuscripts. A few samples of the handwritten documents can be seen in Fig 2.

The following three benchmarks of this database are provided for script identification using different handcrafted features: Local Binary Pattern [17], Quad-Tree Histogram of Templates [18], and Dense Multi-Block Local Binary templates with a Support Vector Machine as a classifier [19]. These script identifiers were used in a document analysis context in [4] and [5]. A benchmark with Deep Learning techniques is also included in our study to demonstrate the usefulness of this database to train deep models.

As a summary, the contributions of the work are listed as follows:

1. A freely accessible multi-script database towards script identification called MDIW-13 (Multi-script Document Identification in the Wild. Number 13 refers to the number of scripts in the dataset).
2. The database provides the possibility of handwritten and printed script identification.
3. The database allows script identification at document, line, and word levels.
4. The database enables cross-training, e.g., train with printed and test with handwriting; train with lines and test with words, among others.
5. A benchmark with different standard parameters and classifiers is given for the sake of comparison.

1.1 PREVIOUS WORKS ON PUBLIC DATABASES

The research community is interested in script identification as it can help in different document analysis tasks, such as OCR, handwriting recognition, document analysis or writer identification [20]. However, the number of script identification databases available is limited, so there is a significant need for publicly available databases.

Regarding the number of scripts, size, and availability of datasets for script identification, the most popular public databases contain only Roman and Arabic scripts. An example include the database of the Maurdor project [21], which is contemporary to the MALIS-MSHD [22]. Other ones can be also used for script identification although they are devised for writer recognition [23]. Also exist databases of printed script [24]. Roman, Bengali and Devanagari databases were compiled in [25]. The authors proposed bi-script and tri-script word-level script identification benchmarks studying the performances in several classifiers. The literature also considers databases with peculiar scripts, which have not been thoroughly investigated in handwriting. An example can be seen in [26], where an Indic database includes the Meitei

TABLE 1
SUMMARY OF PUBLIC SCRIPT IDENTIFICATION DATABASES (H&P = HANDWRITTEN AND PRINTED SAMPLES)

Ref.	H&P	#scripts	#language	#words	#docs
[21]	Yes	2	3	-	2.5K
[22]	No	2	2	-	1.2K
[23]	No	2	2	-	1K
[24]	Yes	2	2	-	5K
SIW[27]	No	13	13	13K	7.7K
[28]	No	11	22	19K	1.5K
[41]	No	3	4	5.6K	-
[42]	No	4	4	104K*	0.7K
Our MDIW	Yes	13	13	87K	1K

H&P: Handwritten and Printed documents.
*word/subword

Mayek script. The SIW-13 [27] is a script identification benchmark with ten different scripts composed of printed text obtained from natural scene images. SIW-13 consists of 10 scripts, including English, Greek, Hebrew, Russian, Arabic, Thai, Tibetan, Korean, Kannada, Cambodian, Chinese, Mongolian, and Japanese. Also, in [28] is found PHDIndic_11, a publicly available dataset focused on 11 official Indic Scripts, which are used in the 22 official languages in India. Previous existing databases are summarized in Table 1.

The database built in this work, named Multi-script Documents In the Wild (MDIW-13), represents a step forward in the field of script identification, with 13 scripts and over 87,000 handwritten and printed words. The main difference between our work and existing databases lies in a large number of scripts employed in the proposed dataset. Some of these 13 scripts are pretty similar, whereas others are somewhat different. Also, some of them can be found in real applications in countries like India, where many Indian and even non-Indian scripts can be found in border control, access, courier companies, or document analysis. This property makes the MDIW-13 database more versatile and interesting in Indic environments. Furthermore, MDIW-13 is composed of text extracted from documents, which is carefully preprocessed to eliminate covariates from background and acquisition protocols.

Another contribution of this paper is to provide a benchmark with well-known and easy to replicate script identifiers. In this case, the benchmark leads to studying the performance impact when the training set uses words or lines or pages or a combination of all three. This kind of experiment is a possibility offered by MDIW-13.

The rest of this paper is organized as follows: Section 2 describes the database and its different features. While Section 3 describes the proposed script identifiers for benchmarking purposes, Section 4 gives the benchmarking design and experiment results. Section 5 closes the paper with a discussion and a conclusion.

2 MDIW-13: A DATABASE FOR SCRIPT IDENTIFICATION

The proposed database consists of printed and handwritten samples from a total of 113 documents, which were scanned from local newspapers and handwritten letters and notes. From these documents, a total of 13,979 lines and 86,655 words from 13 different scripts were extracted. The database is offered with the raw data from direct digitalization and after the preprocessing carried out here. This database can be freely downloaded for research purposes.

2.1 MAIN CHALLENGES IN DATA COLLECTION

Probably, the main challenge in this work was to obtain the data, especially from newspapers, because of the wide variety of scripts involved.

It is possible that some documents for each script could contain some sort of watermark owing to the fact that each document came from a different original native location. This poses a risk

TABLE 2
DATABASE FIGURES

Script	Abbrev	Handwritten			Printed		
		Docs	Lines	Words	Docs	Lines	Words
Arabic/Per	<i>Arab</i>	48	621	3940	51	1082	6202
Bengali	<i>Ban</i>	67	1486	9320	51	466	2557
Gujarati	<i>Guj</i>	3	41	181	32	384	2211
Gurmukhi/ Punjabi	<i>Gurm</i>	6	111	700	115	1062	9104
Devanagari	<i>Hind</i>	21	230	1457	47	397	2782
Japanese	<i>Jap</i>	20	121	441	80	559	1814
Kannada	<i>Kan</i>	15	377	1995	53	582	2157
Malayalam	<i>Mal</i>	12	211	719	70	706	4320
Oriya	<i>Ori</i>	50	1136	7847	42	548	2309
Roman	<i>Rom</i>	90	750	4308	56	961	7627
Tamil	<i>Tam</i>	14	276	1430	46	301	2118
Telugu	<i>Tel</i>	10	154	801	49	483	2126
Thai	<i>Tha</i>	26	473	4472	61	461	3717
Total:		382	5987	37611	753	7992	49,044

Docs: number of documents; Lines: number of lines; Words: number of words

of the document watermark, rather than the script, being recognized, which could be the case with a deep learning-based classifier.

Segmenting text from the backgrounds of some documents was challenging. Even with state-of-the-art segmentation techniques used, the result was unsatisfactory and included a lot of salt and pepper noise or black patches, or some parts of the text were missing.

To avoid these drawbacks and provide a dataset for script recognition, all the documents were preprocessed and given a white background, while the foreground text ink was equalized. Furthermore, all documents were manually examined. Both original and processed documents are included in the database.

To conduct experiments on script recognition at different levels (i.e., document, line and word), each document was divided into lines and each line into words. In this division, a line is defined as an image with two or more words, and a word is defined as an image with two or more characters. It is worth highlighting that the whitespaces were unaltered in any case since the importance of their use in script identification.

In the following subsections, specific challenges in digitalizing both printed and handwritten documents are highlighted.

2.1.1 MAIN CHALLENGES IN DIGITALIZING PRINTED DOCUMENTS

The part of the database from printed documents was acquired from a wide range of local newspapers and magazines to ensure that the samples would be as realistic as possible. The newspaper samples were collected mainly from India (as a wide variety of scripts are used there), Thailand, Japan, the United Arab Emirates, and Europe. A few examples of the printed documents used are shown in Fig 1. The database includes 13 different scripts: Arabic, Bengali, Gujarati, Gurmukhi, Devanagari, Japanese, Kannada, Malayalam, Oriya, Roman, Tamil, Telugu, and Thai.

The newspapers were scanned at a 300 dpi resolution. Paragraphs with only one script were selected for the database (paragraph here means the headline and body text). These paragraphs included multiple fonts, letter styles with italics or bold formats. Nevertheless, some newspapers mix different scripts in the same text. For instance, an Arabic number or a Latin character could be found in a Devanagari script. In these cases, it was tried not to mix those scripts in a single part of the database.

Further, it was tried to ensure that all the text lines were not skewed horizontally. All images were saved in *png* format, using the *script_XXX.png* naming convention, with *script* being an abbreviation or memo for each script, and *XXX*, the file number starting at 001 for each script.

1
2
3
4
5
6
7
8
9
10
11
12
13
14
15
16
17
18
19
20
21
22
23
24
25
26
27
28
29
30
31
32
33
34
35
36
37
38
39
40
41
42
43
44
45
46
47
48
49
50
51
52
53
54
55
56
57
58
59
60
61
62
63
64
65

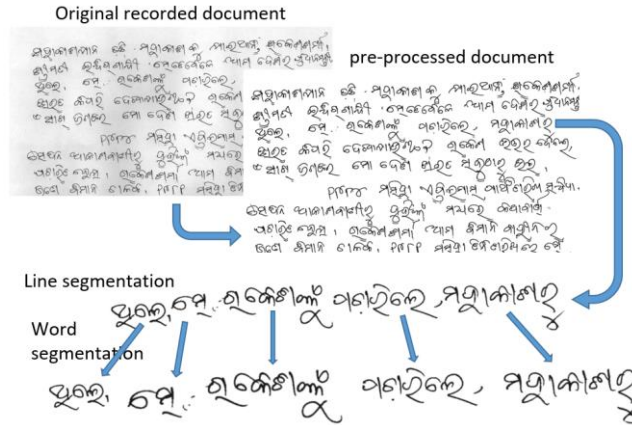

Fig 3 Pre-processed database and line and word segmentation

The scripts, abbreviations, and the number of documents for each script are illustrated in Table 2. Further information about the dataset can be found in Tables A1, A2 and A3 in the Annexes.

2.1.2 MAIN CHALLENGES IN DIGITALIZING HANDWRITTEN DOCUMENTS

Similarly to the printed part, the handwritten database also included 13 different scripts: Persian as Arabic, Bengali, Gujarati, Punjabi, Gurmukhi, Devanagari, Japanese, Kannada, Malayalam, Oriya, Roman, Tamil, Telugu and Thai.

To collect them, several invitations were sent to several native researchers and colleagues from different countries, who were capable of writing documents in their respective scripts, asking for handwritten letters. Each volunteer wrote a document with their pen and with no restrictions on the paper type used. Next, they digitized these documents on unspecified devices and without the limitation of scanning settings, such as resolution, and then sent them to us by e-mail. Consequently, the documents had large ink, sheet and scanner quality variations. All these uncontrolled conditions meant constructing a database as close to the wild as possible. Note that the Roman sheets came from the IAM handwritten database [29]. Some examples are shown in Fig 2. The scripts, abbreviations and the number of documents for each script are shown in Table 2.

2.2 BACKGROUND AND INK EQUALIZATION

Due to the broad quality range of the documents, a two-step preprocessing was performed. In the first step, images are binarized by transforming the background into white, while in the second step, an ink intensity equalization is performed.

Because the background texture, noise, and illumination conditions are primary factors that degrade document image binarization performance, an iterative refinement algorithm was used to binarize [30]. Specifically, the input image is initially transformed into a Bhattacharyya similarity matrix with a Gaussian kernel, which is subsequently converted into a binary image using a maximum entropy classifier. Then a run-length histogram is used to estimate the character stroke width. After noise elimination, the output image is used for the next round of refinement, and the process terminates when the estimated stroke width is stable. However, some documents are not correctly binarized, and in such cases, a manual binarization is performed using local thresholds. All the documents were reviewed, and some noise was removed manually.

1
2
3
4
5
6
7
8
9
10
11
12
13
14
15
16
17
18
19
20
21
22
23
24
25
26
27
28
29
30
31
32
33
34
35
36
37
38
39
40
41
42
43
44
45
46
47
48
49
50
51
52
53
54
55
56
57
58
59
60
61
62
63
64
65

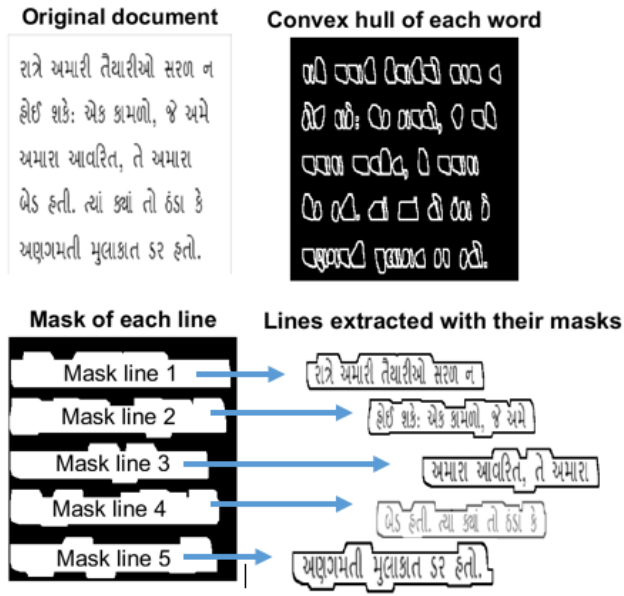

Fig 4 Line detection procedure

Sometimes, collaborators made mistakes during the writing of the letter. Such mistakes resulted in blurred handwriting with scribbles in some parts of the letters which were identified and repaired by adding white boxes to these scribbled parts of the documents.

For ink equalization, an ink deposition model proposed in [31] was used. All the black pixels on the binarized images were considered ink spots and correlated with a Gaussian width of 0.2 mm. Finally, the image was equalized to duplicate fluid ink, as in [32]. The result can be seen in Fig 3.

2.3 TEXT LINE SEGMENTATION

For the lines from a document to be segmented, they must be horizontal; otherwise, a skew correction algorithm must be used [17].

For line segmentation, each connected object/component of the image is detected, and its convex hull obtained, as shown in Fig 4. The result is dilated horizontally in order to connect the objects belonging to the same line (see Fig 4) and each connected object is labelled. The next step is a line-by-line extraction, performed as follows:

1. Select the top object of the dilated lines and determine its horizontal histogram.
2. If its histogram has a single maximum, then it should be a single line, and the object is used as a mask to segment the line (see Fig 4).
3. If the object has several peaks, it is assumed that there are several lines. To separate them, the following steps are followed:
 - a. The object is horizontally eroded until the top object contains a single peak.
 - b. The new top object is dilated to recover the original shape and is used as a mask to segment the top line.
4. The top line is deleted, and the process is repeated from step 1 to the end.

This automatic segmentation procedure was initially used. Later, each line was manually examined. Any lines that had been wrongly segmented were manually repaired. The lines were saved as image files and named using the *script_xxx_yyy.png* format, where *yyy* is the line number, *xxx* is the document number and *script* is the abbreviation for the script, as previously mentioned. Fig 3 presents an example of a segmented line for handwriting. These images are saved in grayscale format. The number of lines per script can be seen in Table 2.

2.4 WORD SEGMENTATION

The words were segmented from the lines in two steps, with the first step being completely automatic. Each line was converted to a black and white component, a vertical histogram was obtained, and points where the value of the histogram was found to be zero were identified as the gaps or the intersection. Gaps wider than one-third of the line height were labelled as word separations.

In the second step, failed word segmentations were manually corrected. Each word was saved individually as a black and white image. The files were named using the *script_xxx_yyy_zzz.png* format, with *zzz* being the word number of the line *script_xxx_yyy*. For instance, a file named *roma_004_012_004.png* contains the black and white image of the fourth word on the 12th line of the 4th document in Roman script. An example of the segmentation result can be seen in Fig 3. The number of words per script is shown in Table 2.

In Thai and Japanese, word segmentation is conducted heuristically because their lines consist of two or three long sequences of characters separated by a greater space. This is because there is generally no gap between two words in these scripts, and contextual meaning is generally used to decide which characters comprise a word. Since no contextual meaning is applied in the current database, the following approach for pseudo-segmentation of Thai and Japanese scripts was used: for each sequence of characters, the first two characters are the first pseudo-word; the third to the fifth characters are the second pseudo-word; the sixth to the ninth characters are the third pseudo-word, and so on, up to the end of the sequence.

It should be noted that in this work, our intention is not to develop a new line/word segmentation system. Only a simple procedure is used to segment lines and words in a bid to build our database. In this way, a semi-automatic approach is worked out, with human verification and correction in the case of erroneous segmentation.

3 SCRIPT IDENTIFIERS

For database benchmarking, an automatic script identifier is required. For a more general benchmarking of the database, up to four automatic script identifiers are used. The two firsts are based on the classical feature-classifier structure, and the last two are based on deep learning. Our motivation in defining the benchmarks is that they are easy to replicate by third parties, allowing them to establish a baseline in these three cases. To this aim, the systems are accessible in several toolboxes under different programming languages.

In feature-classifier script identifiers, the script feature extractors used in this section are based on local patterns. Specifically, we used Local Binary Patterns (LBP) [17], Quad-Tree histograms [18], and Dense Multi-Block LBPs [19]. Such features can be seen as constituting a unifying approach, thus bringing together the traditional appearance and structural approaches. When these techniques are applied to black and white images, local patterns can be considered as the concatenation of the binary gradient directions. The histogram of these patterns contains information on the distribution of the edges, spots, and other local shapes in the script image, which can be used as features for script detection. The following section describes the features used for script identification. The classifier used for script identification, which is a Support Vector Machine (SVM) [33], is also described.

For script identification based on deep learning, two popular state-of-the-art image recognition architectures based on Convolutional and Residual layers are used for benchmarking.

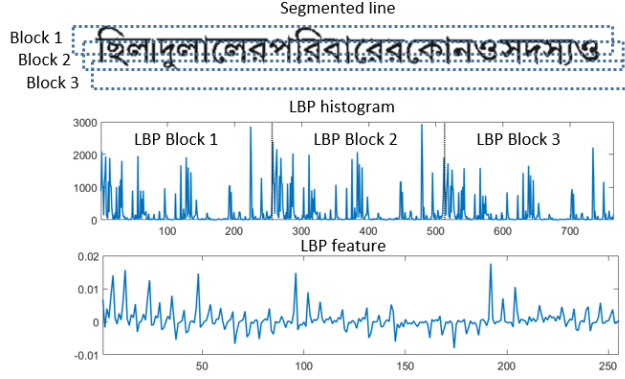

Fig 5. LBP features for script identification

3.1 LOCAL BINARY PATTERNS FOR SCRIPT DETECTION

Local Binary Patterns: The original LBP [17] operator labels the pixel of an image by thresholding the 3×3 neighborhood around each pixel and concatenating the results binomially to form a number. Assume that a given image is defined as $I(Z) = I(x, y)$. The LBP operator transforms the input image to $LBP(Z)$ as follows:

$$LBP(Z_c) = \sum_{p=0}^7 s(I(Z_p) - I(Z_c)) \cdot 2^p, \quad (1)$$

where $s(l) = \begin{cases} 1 & l \geq 0 \\ 0 & l < 0 \end{cases}$ is the unit step function and $I(Z_p)$ is the 8-neighborhood around $I(Z_c)$.

LBP feature: The $LBP(Z)$ code matrix contains information about the structure to which the pixel belongs – a stroke edge, a stroke corner, a stroke end and so on. It is assumed that the distribution of these structures defines the script. The distribution is obtained as the histogram of the $LBP(Z)$, named h_{LBP} . As the histogram is a function of the size of the image, it is normalized as $hn_{LBP} = h_{LBP}/\text{sum}(h_{LBP})$. The length of this vector is 255 since the LBP value for the background is discarded.

The problem with the histogram is that it leads to a loss of spatial distribution of the structures. To include the spatial distribution in the LBP feature, the image is divided into a number of zones so as to calculate the histogram in each zone as a vector hn_{LBP} , and then concatenating them. After several experiments were conducted, and a range of smaller and larger zone sizes were tested, the best performance was obtained when dividing the lines and words into three equal horizontal regions, which overlapped by 30%. Thus, the vector $H_{LBP} = [hn_{LBP}^1, hn_{LBP}^2, hn_{LBP}^3]$ of 765 components was worked out.

Finally, this vector of size 765 was reduced to 255 by calculating the DCT of H_{LBP} and by selecting from the second to the 256th component. This new vector is the LBP feature used to identify scripts in the cases of lines and words. An example of this procedure is illustrated in Fig 5.

In the case of a full document with several lines, the LBP features of all the lines were combined at the score level.

3.2 QUAD-TREE HISTOGRAM OF TEMPLATES FOR SCRIPT DETECTION

In this section, it is proposed a new and efficient feature for script identification. It is based on a quad-tree computation of the Histogram of Templates (HOT). It was introduced for signature verification in [18]. Specifically, this feature is an extension of the HOT, which is introduced to highlight local directions.

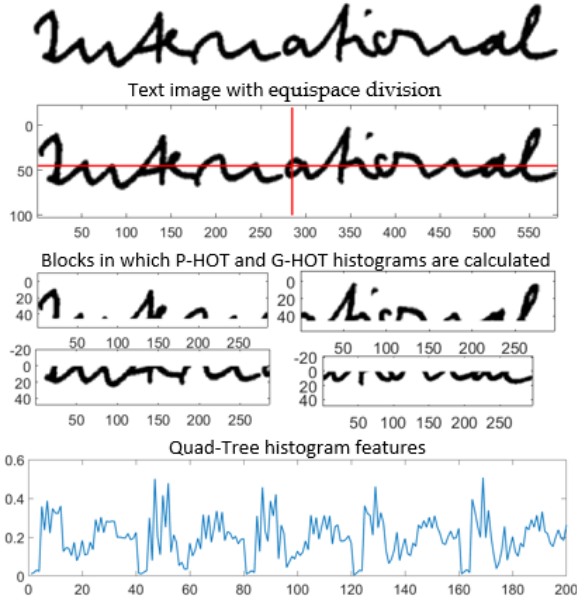

Fig 6. Quad-Tree Histogram for script identification

The implementation of the HOT employs a set of 20 templates to describe the segment orientations by comparing the positional relationship between a pixel and its neighborhood references. Specifically, a sliding window covering 3×3 pixels is applied to the text image to count the number of pixels that fit this template. The resulting counts constitute the histogram of the templates. In [18], HOT is computed by considering the pixel and gradient information. This vector is calculated in the following steps:

1. Pixel information-based HOT (P-HOT). There are 20 possible templates, and each template corresponds to a possible combination of adjacent pixels Z_1 and Z_2 with pixel $Z = (x, y)$. For each template and pixel Z , if the grey value $I(Z)$ is greater than the grey value of the two adjacent pixels $I(Z_1)$ and $I(Z_2)$, then add 1 to the value of this template. The vector of the tally of these 20 templates is termed a histogram of templates, which is the feature vector.
2. Gradient information-based HOT (G-HOT): For each template, if the gradient magnitude $Mag(Z)$ of a pixel $Z = (x, y)$ is greater than the gradient magnitude of the two adjacent pixels, i.e., Z matches the condition $Mag(Z) > Mag(Z_1) \wedge Mag(Z) > Mag(Z_2)$, then add 1 to the value of this template. There are 20 possible combinations of adjacent pixels Z_1 and Z_2 for each pixel Z , and so there are 20 templates. Similar to P-HOT, the vector of the tally of the 20 templates is known as the gradient histogram of templates, which acts as the feature vector.

The HOT template consists of the 20 values of the P-HOT feature concatenated with the 20 values of the G-HOT feature, for a total of 40 values. To facilitate the verification process, after the HOT calculation for each region, it is performed an L2 normalization on the 40 values of the HOT to scale in the margin between 0 and 1.

The quad-tree structure considers the spatial property of a local shape by dividing it into four cells at different levels. The center of gravity of the pixels is assigned to the center of the equi-mass partition. This overcomes empty computing cells, especially at deeper levels. Therefore, HOT is locally computed at each level of the quad-tree structure, while the whole image feature is obtained by concatenating all local HOT features.

Heuristically, it was used the HOT features at the first and second quad-tree levels. There is the full image at the first level, while at the second, there are four partitions. Hence, there are 5

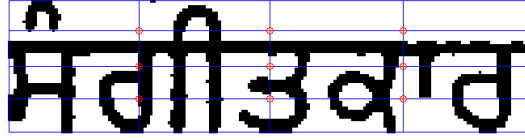

Fig 7. Example of the 12 overlapped patches on a word; Red circles: patch centers

HOT features, which run to a 200-dimensional feature vector. An example of this procedure is shown in Fig 6.

3.3 SCRIPT FEATURES BASED ON DENSE MULTI-BLOCK LBP FEATURES

Dense Multi-Block LBPs (D-LBP) are new features that have recently been proposed for script identification. They are based on a spatial pyramidal architecture of the multi-block LBP (MBLBP) histograms proposed in [34].

Specifically, an image I of n_x rows and n_y columns, at level $l = 1, 2, \dots, L$, is divided into N_l^x by N_l^y patches of height h_l and width w_l . The patches are uniformly distributed in the image. For each patch, the histogram of MBLBP descriptors at s different scales is worked out. The feature consists of all the concatenated histograms, which result in a feature of dimension $\sum_{l=1}^L 256 s N_l^x N_l^y$.

In our case, for script identification, it is heuristically defined $L = 2$ and $s = 4$. At the first level, $N_1^x = 1$, $N_1^y = 1$, $h_1 = n_x$ and $w_1 = n_y$; at the second level, $N_2^x = 3$, $N_2^y = 3$, $h_2 = n_x/2$ and $w_2 = n_y/2$, and so the 9 (3×3) patches are 25% overlapped. Hence, the final feature vector dimension is 10,240. An example of the distribution of the patches is shown in Fig 7 for a Gurumukhi word. This feature vector was implemented using the Scenes/Objects classification toolbox freely available in the Matlab central files exchange.

3.4 CLASSIFIER

A Support Vector Machine (SVM) was used as a classifier because of the large dimension of the feature vectors. An SVM is a popular supervised machine learning technique that performs an implicit mapping into a higher dimensional feature space. This is the so-called kernel trick. After the mapping is completed, the SVM finds a linear separating hyperplane with maximal margin to separate data from this higher dimensional space.

Least Squares Support Vector Machines (LS-SVM) are reformulations of standard SVMs which solve the indefinite linear systems generated within the latter. Robustness, sparseness, and weightings can be imposed on LS-SVMs where needed, and a Bayesian framework with three levels of inference is then applied [33].

Although new kernel functions are being proposed, the most frequently used kernel functions are the linear, polynomial, and Radial Basis Function (RBF). The present study uses the RBF kernel for LBP and Quad-Tree features and a linear kernel for Dense LBP.

SVM or LS-SVM makes a binary decision, while, in this study, multi-class classification for script identification is carried out by adopting one-against-all techniques. Grid searches were carried out on the hyper-parameters in 2-fold cross-validation to select the parameters in the training sequence.

3.5 DEEP NEURAL NETWORK ARCHITECTURES

Deep Neural Networks have demonstrated their potential in many computer vision tasks when sufficient data is available. They are proposed to evaluate the usefulness of this new database in training deep learning architectures. The more than 30K labelled words included in this database constitute a valuable new resource for the scientific community.

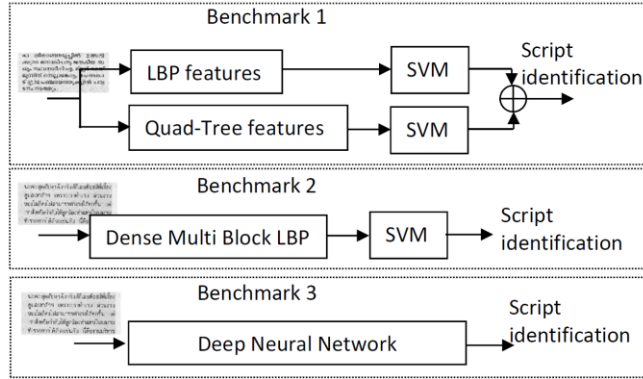

Fig 8. Benchmarks constructed in the paper

Our experiments employed two popular state-of-the-art Convolutional Neural Networks architectures based on VGG [35] and ResNet¹ [36] models. These architectures have been chosen as examples of data-driven learning models employed in image classification challenges. During the last decade, Deep Convolution Neural Networks has boosted the performance of Computer Vision applications, including text classification [37][38]. The VGG architecture used in our experiments is based on the traditional 2D convolutional layers. The ResNet model improves the traditional convolutional architectures introducing the residual connections between convolutional layers (i.e., shortcuts between layers). The residual connections improve the training process of the network, providing higher performance. The visual information of the strokes such as directionality, curvature, frequency, or density is critical to classify the different scripts. In both cases (VGG and ResNet), the 2D convolutional filters learned during the trained process present a great capacity to model such visual patterns.

Each input image is subsampled at the preprocessing step into 60×60 -pixel sub-images using a sliding window (50% overlap). In order to improve the generalization capability of the model, data augmentation techniques are applied (shear, zoom, width, and height shift).

The first architecture evaluated is a VGG architecture. This network is composed of two convolutional layers followed by one fully connected layer with dropout (0.25) and 13 units (softmax activation). The ReLU (Rectified Linear Unit) activation function was used in all hidden layers and a max-pooling layer with a filter size of 2×2 after each convolutional layer. The first convolutional layers have 32 filters of size 3×3 and stride 1, and the second convolutional layer has 64 filters of 3×3 . This network comprises more than 3M parameters.

The second architecture is a Residual Neural Network architecture. This network comprises three convolutional blocks and a dense output layer (13 output units and softmax activation). The first convolutional block is composed of a convolutional layer (64 filters of size 7×7), and a 3×3 max pool layer (stride 2). The second and third blocks consist of identity and convolutional blocks. Our identity block includes a series of three convolutional layers with a bypass connection between the input of the identity block and the output of the third convolutional layer. The second convolutional block includes three convolutional layers (64, 64, and 256 filters of size 1×1 , 3×3 , and 1×1 respectively), a convolutional layer shortcut (128 filters of size 1×1), two identity blocks (64, 64, and 256 filters of size 1×1 , 3×3 , and 1×1 respectively) without the bypass connection. The third block has three convolutional layers (128, 128, and 512 filters of size 1×1 , 3×3 , and 1×1 respectively); and three identity blocks with this same series of filters per convolution. Batch normalization and a ReLU activation

¹Both models are provided together with the MIDW-13 database.

TABLE 3
NUMBER OF DOCUMENTS, LINES AND WORDS FOR TRAINING

Script	Abbrev	Handwritten			Printed		
		Docs	Lines	Words	Docs	Lines	Words
Arabic/Per	<i>Arab</i>	5	88	570	14	256	1996
Bengali	<i>Ban</i>	3	55	401	27	234	1608
Gujarati	<i>Guj</i>	2	32	144	22	190	1229
Gurmukhi/ Punjabi	<i>Gurm</i>	4	88	560	39	468	3629
Devanagari	<i>Hind</i>	15	184	1165	33	215	1706
Japanese	<i>Jap</i>	4	96	352	64	447	1451
Kannada	<i>Kan</i>	3	122	872	38	302	1183
Malayalam	<i>Mal</i>	9	168	575	26	314	2370
Oriya	<i>Ori</i>	3	49	333	25	348	1660
Roman	<i>Rom</i>	9	83	558	14	244	1574
Tamil	<i>Tam</i>	3	150	873	36	240	451
Telugu	<i>Tel</i>	3	123	640	32	264	1261
Thai	<i>Tha</i>	4	158	1828	27	194	1856
Total:		67	1396	8871	397	3716	21974

Docs: number of documents; Lines: number of lines; Words: number of words

function after each convolutional layer were employed. This network comprises more than 1.5M parameters.

The following are the implementation details of the training for both architectures: batch size of 128, Adam optimizer with a 0.001 learning rate, random initialization of the weights, and a number of epochs equal to 30 and 10 for handwritten and printed samples, respectively (printed models converge faster than handwritten ones). Both VGG and ResNet models were trained from scratch (i.e. we have not used pre-trained models). The architectures (i.e., number of layers, number of neurons per layer, activation functions) and the hyperparameters (i.e., optimizer, batch size, epochs, etc...) presented in this work are the results of several experiments. We have prioritized the configuration with the best performance and a lower number of parameters (i.e., fewer layers and neurons) during the experimentation. Furthermore, we have discarded the use of pre-trained models to guarantee a fair comparison between benchmarks (i.e., the same data was used to train all three benchmarks).

4 BENCHMARKING: EXPERIMENTS

The benchmarking consists of classification experiments with the above-described techniques to estimate the script of a given document or line or a word among those included in the dataset. It should be borne in mind that the present benchmark attempts to measure the reach and range of the database built with well-known state-of-the-art classifiers and that it is not aimed to propose a new script identifier.

Three different benchmarks were constructed for this estimation. The first one uses a classifier based on a score level combination of LBP and Quad-Tree features. The second one is based on Dense Multi-Block LBP features. It is worth pointing out that the combination of these two systems improves the performance by about 10%. Finally, the third is constructed with two popular Deep Neural Network architectures (DNN). The three benchmarks are illustrated in Fig 8.

4.1 TRAINING SEQUENCES

Defining the training sequences is paramount for a fair comparison of results. Thus, the classifiers for each printed and handwritten document script should be trained as similarly as possible.

However, a database of handwritten or printed documents is inherently unbalanced because each of its constituent documents contains a different number of lines, the lengths of the lines are different, and the word sizes differ between the scripts. Therefore, training each classifier with a similar number of documents, lines, or words does not guarantee equality of training or the fair comparison of results.

Consequently, instead of training each classifier with a given number of documents, lines, or words, it was decided to train them with a similar number of pixels. In this way, one classifier was trained with 100 images and other with 150 because the training images of the second classifier contain less text than those of the first classifier.

In analyzing the database, it was heuristically decided to train each classifier with several images whose accumulated number of pixels would be approximately 2M. The numbers of documents used to train each classifier are shown in Table 3. This training sequence breaks down into the following proportions: 21.03% of handwritten words, 21.82% of handwritten lines, and 15.06% of handwritten documents. In the printed dataset, it was assumed a training scenario with 51.06% of documents, 45.2% of lines, and 45.85% of printed words. Therefore, there is room for a statistically meaningful test. Further information about the training partition of the dataset can be found in Tables A4, A5, and A6 in the Annexes.

To ensure experimental repeatability, it was predetermined training and test sequences. The training images appeared first and in numerical order (e.g., the first 18 Devanagari handwritten documents or the first 256 Arabic printed lines, or the first 1608 Bengali printed words, etc.), and the rest of the images were used for testing.

Therefore, there were the next six training sequences: printed documents, printed lines, printed words, handwritten documents, handwritten lines, and handwritten words. Similarly, there were the following six testing sequences: printed documents, printed lines, printed words, handwritten documents, handwritten lines, and handwritten words. The twelve sequences were disjointed. It should also be noted that all the experiments reported were separately tested with these testing sequences.

TABLE 4
DESCRIPTION OF THE TASKS PER BENCHMARK

	Training with:
Task 1 (one classifier per type of image and script)	Handwritten docs
	Handwritten lines
	Handwritten words
	Printed docs
	Printed lines
Task 2 (one classifier for handwritten and another for printed per script)	Printed words
	Handwritten docs, lines and words
Task 3 (a single classifier per script)	Printed docs, lines and words

4.2 DESCRIPTION OF THE TASKS

Each benchmark was evaluated by performing three tasks, which depend on the different training sequences and are summarized in Table 4. The test sequence is the same for each task, which is composed of six different data types: printed documents, printed lines, printed words, handwritten documents, handwritten lines, and handwritten words. These were the remaining specimens of the database, which were not used in training, as shown in Table 3.

TASK 1: This task aims to study the behavior of the database at the document, line, and word levels [39] for printed and handwritten documents separately. Hence, each classifier is oriented to a specific type of document (document, line, or word and printed or handwritten) per script.

Evaluation protocol of task 1: It requires as many classifiers as scripts and type of image: document, line, and word in both printed or handwritten modality. Also, as the database includes handwritten and printed specimens, the total number of classifiers used in this task is $13 \times 3 \times 2 = 78$. These have been individually trained with the number of images indicated in Table 3. Once the remained images are tested, a 13×13 confusion matrix is worked out with the performances given in percent (%) of each type of image per script. Then, the final identification performance is obtained as the average of the main diagonal of the performances in percentage.

TASK 2: This task aims to study the database behavior when the script classifier is oriented to being printed or handwritten, regardless of the type of document. Consequently, the training of a particular classifier will include documents, lines, and words of a specific script and type of document: printed or handwritten.

Evaluation protocol of task 2: In this task, each classifier was trained with three training sequences of handwritten or printed documents for each script. In total, $13 \times 2 = 26$ classifiers were trained. It should be noted that the training words belong to the training lines, which in turn correspond to the training documents. The trained classifiers were tested with the six types of testing images, regardless of their type and modality. Then 13×13 confusion matrices were obtained in each case for each script, which were averaged in the same terms as in Task 1. Following the same strategy as task 1, the main diagonal values were averaged from the script confusion matrices to obtain the final performance.

TASK 3: The goal of this task is to study the database behavior independently of the input to the script classifier. This can be a printed or handwritten document or line or word.

TABLE 5
HIT RATIO OF EACH SCRIPT IDENTIFIER IN BENCHMARK 1

Train with	Test with					
	Handwritten			Printed		
	Docs	Lines	Words	Docs	Lines	Words
Task 1						
Handwritten docs	79.30%	16.96%	5.58%	22.75%	7.02%	4.85%
Handwritten lines	60.83%	87.04%	54.52%	19.66%	25.02%	11.11%
Handwritten words	48.09%	88.50%	84.02%	37.36%	33.04%	26.69%
Printed docs	35.03%	37.09%	31.57%	90.73%	78.48%	41.40%
Printed lines	21.02%	16.14%	18.90%	45.51%	94.41%	77.17%
Printed words	17.83%	23.76%	30.73%	44.94%	94.46%	86.36%
Task 2						
Handwritten docs, lines and words	81.21%	92.49%	83.10%	35.67%	32.09%	26.63%
Printed docs, lines and words	35.35%	34.10%	36.97%	88.20%	94.55%	86.55%
Task 3						
Printed and Handwritten docs, lines and words	79.62%	91.96%	83.08%	89.33%	94.71%	87.52%

Evaluation protocol of task 3: It requires 13 classifiers, one per script, which are trained with all types of documents, both printed and handwritten. After the testing, the final performance is obtained in the same terms as tasks 1 and 2.

5 EXPERIMENTAL RESULTS

In this section, different benchmark results are provided to get the comparative idea of different results obtained from our experiments.

5.1 BENCHMARK 1: HANDCRAFTED FEATURE COMBINATION (LBP+QUAD-TREE)

In the present benchmarking, the classifier combines two script identifiers at the score level. The first script identifier is based on LBP features and a Support Vector Machine, while the second relies on Quad-Tree features and a Support Vector Machine. The score level combination is carried out, weighting each score at 50%. The following are the three experiments conducted in this benchmarking.

For task 1, there are six options in the training and six options in the test, which comes to a tally of 36 different experiments shown in Table 5. Their Cumulative Matching Curves (CMC) are depicted in Fig 9.

As expected, the performance with printed text was better than that with handwritten text, probably because of the lower variability in the printed text. Also, the line-based test offered the best performance, possibly because lines contain enough information laid out in a straightforward structure. Indeed, for the printed and handwritten document cases, the classifiers trained with words work better with lines than words. This could be because line features are more stable than word features.

There is a significant decrease in the hit ratio when the training and testing images do not belong to the same case. For this reason, it was decided to train the classifier with documents, lines, and words (task 2) to build a classifier more robust to the input type: document or line or word.

In the case of task 2, according to the evaluation protocol, 12 results were obtained and are given in Table 5, while the CMC curves are shown in Fig.9.

1
2
3
4
5
6
7
8
9
10
11
12
13
14
15
16
17
18
19
20
21
22
23
24
25
26
27
28
29
30
31
32
33
34
35
36
37
38
39
40
41
42
43
44
45
46
47
48
49
50
51
52
53
54
55
56
57
58
59
60
61
62
63
64
65

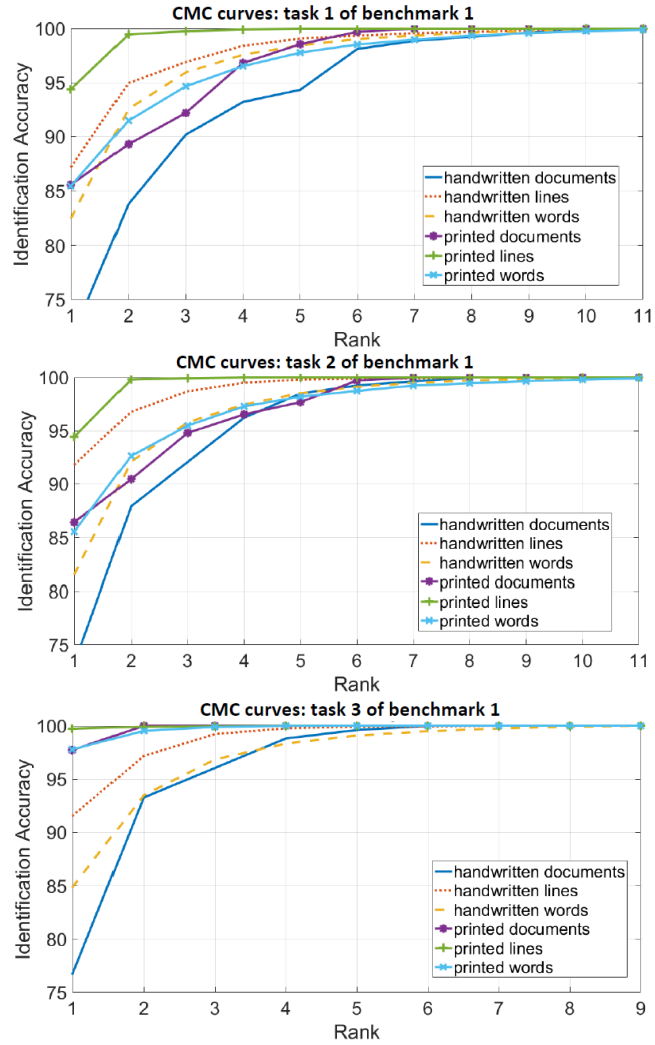

Fig 9 CMC curves of the three tasks of Benchmark 1. These CMC curves correspond to the results in bold in Table 5.

On average, the result of the second experiment, i.e., the procedure for training a classifier for printed and handwritten text, including all documents, lines, and words from the training sequence, gives a better performance than for the first experimental protocol. Similar to the first experiment, the best results were obtained when testing with lines.

Moving on to task 3, the six results of the six experiments carried out, are given in Table 5, and the CMC curves are shown in Fig.9.

Similar trends are found in the results: the best result is obtained at the line level, while printed text outperforms the handwritten scenario.

A confusion matrix is shown in Table 6. The main confusions seen here are between Kannada and Telugu, Telugu and Bengali, Gujarati and Thai, and Oriya and Bengali, as shown in Fig.10.

TABLE 6
 CONFUSION MATRIX OF BENCHMARK 1
 TASK 3 IN THE CASE OF HANDWRITTEN LINES IN %

	Arab	Ban	Guj	Gurm	Hind	Jap	Kan	Mal	Ori	Rom	Tam	Tel	Tha
Arab	99.44	0.00	0.00	0.19	0.00	0.00	0.00	0.00	0.00	0.37	0.00	0.00	0.00
Ban	0.49	89.24	0.00	2.17	0.07	0.77	0.00	0.00	5.24	1.68	0.07	0.28	0.00
Guj	0.00	0.00	33.34	0.00	0.00	0.00	0.00	11.11	0.00	0.00	22.22	11.11	22.22
Gurm	0.00	0.00	0.00	71.43	28.57	0.00	0.00	0.00	0.00	0.00	0.00	0.00	0.00
Hind	0.00	2.04	0.00	0.00	95.92	0.00	2.04	0.00	0.00	0.00	0.00	0.00	0.00
Jap	0.00	0.00	0.00	0.00	0.00	96.00	0.00	4.00	0.00	0.00	0.00	0.00	0.00
Kan	0.00	0.00	0.00	0.00	0.00	0.00	94.13	0.78	0.00	0.00	2.74	2.35	0.00
Mal	0.00	0.00	0.00	0.00	0.00	0.00	6.97	90.70	2.33	0.00	0.00	0.00	0.00
Ori	0.18	5.52	0.00	0.46	0.00	0.18	1.84	0.09	89.16	1.10	0.46	1.01	0.00
Rom	1.05	0.15	0.15	0.00	0.15	0.15	0.00	0.30	0.15	97.75	0.00	0.15	0.00
Tam	0.00	0.00	0.00	0.00	0.00	0.00	0.00	3.97	0.00	0.00	96.03	0.00	0.00
Tel	0.00	0.00	0.00	0.00	0.00	0.00	6.45	0.00	0.00	0.00	0.00	93.55	0.00
Tha	0.00	0.00	0.00	0.00	0.00	0.00	0.32	4.76	0.00	0.00	0.00	6.98	87.94

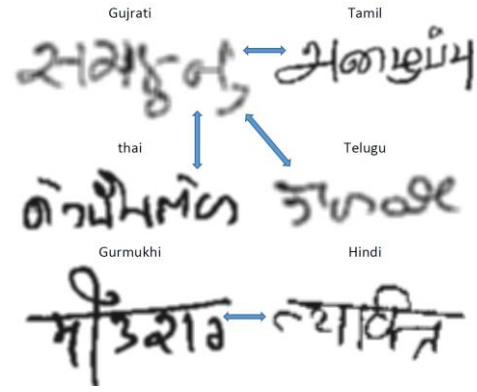

Fig 10 Samples of the most confused scripts in Benchmark 1, Task 3. Arrows mean most common confusion

TABLE 7
 HIT RATIO OF EACH SCRIPT IDENTIFIER IN BENCHMARK 2

Train with	Test with					
	Handwritten			Printed		
	docs	lines	words	docs	lines	words
Task 1						
Handwritten docs	82.01%	20.54%	7.46%	26.67%	10.04%	7.11%
Handwritten lines	65.93%	89.78%	59.25%	23.44%	21.02%	9.01%
Handwritten words	69.92%	89.89%	88.01%	36.15%	34.64%	21.67%
Printed docs	32.23%	38.45%	36.78%	89.23%	80.99%	47.83%
Printed Lines	26.78%	19.01%	17.89%	47.04%	95.51%	79.83%
Printed words	19.81%	28.90%	31.72%	49.67%	96.11%	88.06%
Task 2						
Handwritten docs, lines and words	83.27%	93.45%	86.51%	39.89%	34.70%	29.04%
Printed docs, lines and words	37.65%	35.16%	39.78%	90.23%	95.25%	89.33%
Task 3						
Printed and Handwritten docs, lines and words	80.90%	92.33%	86.71%	91.23%	96.70%	88.01%

5.2 BENCHMARK 2: HANDCRAFTED FEATURE (DENSE MULTI-BLOCK LBP)

The second benchmark uses an SVM classifier with Dense Multi-Block LBP features. The three experiments performed in the previous benchmark were repeated in this one. All results from the second benchmark are highlighted in Table 7.

Regarding task 1, and similarly to the previous Benchmark 1, the performance with printed text was better than with handwritten text because of the lower intra-class variability in the printed text. Moreover, the performance at the line level was more accurate than at the document and word levels. Besides, in the cross-document scenario, a similar pattern with Benchmark 1 can be seen. On the other hand, the best results were obtained when training with printed and tested with handwritten text. Overall, better results were achieved by Benchmark 2 versus Benchmark 1.

In task 2, a similar pattern of results was found to those of Benchmark 1; and the results achieved in the scenario mainly were better than those in Benchmark 1.

TABLE 8
HIT RATIO OF EACH SCRIPT IDENTIFIER IN BENCHMARK 3 - RESNET MODEL

Train with	Test with					
	Handwritten			Printed		
	docs	lines	words	docs	lines	words
Task 1						
Handwritten docs	78.43%	47.54%	39.49%	27.14%	28.96%	27.87%
Handwritten lines	47.41%	89.92%	71.68%	33.02%	30.09%	29.35%
Handwritten words	47.38%	87.91%	87.72%	42.17%	48.63%	43.75%
Printed docs	18.19%	29.01%	25.55%	93.55%	95.64%	85.16%
Printed Lines	19.88%	30.82%	28.08%	91.28%	99.53%	95.67%
Printed words	18.02%	29.67%	30.56%	90.28%	96.81	96.46%
Task 2						
Handwritten docs, lines and words	86.24%	92.48%	89.14%	52.58%	52.02%	45.61%
Printed docs, lines and words	21.49%	36.87%	30.93%	96.84%	99.82%	98.57%
Task 3						
Printed and Handwritten docs, lines and words	29.26%	40.04%	34.20%	96.48%	99.78%	99.09%

Similar to the two previous sets of experiments, in the third task of Benchmark 2, a similar pattern was found, with better accuracy than in Benchmark 1.

5.3 BENCHMARK 3: DEEP NEURAL NETWORKS

The third benchmark was carried out with the above-mentioned DNN architectures. For a fair comparison, it was repeated the experimental protocol proposed for the previous benchmarks. All the results obtained for this third benchmark are included in Table 8. The ResNet architecture clearly outperforms the VGG architecture with a performance improvement of 2-4% and 10% for printed and handwritten samples, respectively. The rest of the analysis will be focused on the performance of the ResNet model.

Task 1 with Deep Neural Networks showed a very competitive performance for printed samples. The results obtained outperformed the first benchmarks for printed data. As in previous experiments, lines showed the best performance, followed by words and documents. When large databases are available, deep representations are capable of achieving almost 99% accuracy for printed patterns.

The performance obtained for handwritten samples was similar to the first experiments with the Benchmarks 1 and 2. The gap between the performance obtained for printed samples and handwritten samples is caused by the large intra-class variability of the writers. The Deep Neural Networks are unable to reach a good generalization because of this larger variability. There is room for improvement and training deep representations capable of dealing with writer variability is a key challenge in this area. The MDIW-13 provides an extensive database to train and evaluate these models.

TABLE 9
 COMPARISON OF HIT RATIO FOR VGG AND RESNET ARCHITECTURES IN BENCHMARK 3.
 ACCURACIES ARE OBTAINED AVERAGING THE RESULTS MARKED WITH BOLD FONT IN TABLE 8

	Task 1		Task 2		Task 3	
	Handwritten	Printed	Handwritten	Printed	Handwritten	Printed
VGG	77.69%	94.06%	79.36%	94.82%	27.64%	94.74%
ResNet	85.35%	96.51%	89.28%	98.41%	34.50%	98.45%

For the second task, Deep Neural Networks achieved the best performances with printed samples. Once again, the performance obtained for handwritten samples was poor in comparison with the other two benchmarks. The more significant number of samples used here produced a slight improvement for printed samples.

In task 3, unlike the above benchmarks, the results in the printed case were not improved and produced a clear drop in performance in the handwritten case. These results suggest that handwritten and printed models should be trained separately for Deep Neural Networks. As commented before, writer variability is not well modelled by the DNN. Therefore, it is clear that the training strategy depends on the classifier and the features in comparing the three benchmarks.

Finally, Table 9 compares the performance achieved by the two Deep Neural Network architectures evaluated. The Hit Ratio for each task and type of sample was obtained by averaging the Hit Ratios obtained when the training and test samples belong to the same class (e.g., handwritten documents). The results averaged in Table 9 correspond to the average of the results highlighted with bold font in Table 8. The results show the superior performance of the ResNet architecture with performance improvement of around 10% for handwritten experiments and 2-4% for experiments with printed samples. These results encourage us to find new Deep Neural Network architectures capable of modelling the variability in handwritten classification.

5.4 DISCUSSION

Globally speaking, this paper aimed to introduce a new multi-script database that allows the development of new algorithms, applications, and a simple and easy-to-go benchmark to facilitate the comparison.

The benchmarking reveals some new possibilities of using the database. For instance, the division in documents, lines, and words enables the training of a script model with a level, for instance, lines, and testing at other levels, for instance, words. The results obtained show that the technology requires improvements due to the lack of generalization of the identifiers when moving the test from one level, e.g. words, to another, e.g. documents.

Furthermore, the benchmarking highlight an interesting direction when training the model with images from all the levels and testing with images of different levels. Furthermore, the model with the best identification rates at the three levels in the three conducted experiments is the model trained with documents and lines plus words. It suggests that general identifiers at the three levels are possible and how to train them in practical applications. Even if the lines are obtained from the documents and the words from the lines or an artificial line or document are build up from words or lines.

Instead, a global model for printed and handwritten is still far from reasonable results, mainly in the case of deep learning, at least with the well-established classifiers used in this work.

Regarding the benchmark, the idea of a simple and easy-to-go benchmark to facilitate the comparison has its limitations. To this aim, training and testing set as functions to calculate the parameters and implement the classifiers have been defined. It leads to repeatability research since the used methods are easy to find in scientific free software packages. From now

1
2
3
4
5 onwards, developing new state-of-the-art script identifiers and improving database partition
6 is a task done by the researcher enticed by this new public database. Further works should be
7 done to explore novel data-driven learning frameworks. This research line includes novel
8 architectures as well as new learning frameworks, including synthetic data to improve the
9 generalization capacity of the models (e.g., Generative Adversarial Networks or Variational
10 Autoencoders). Obviously, this database can also be enlarged with new scripts and more
11 samples from the scripts to make it more appealing.
12

13 14 15 **6 CONCLUSION** 16

17 A new dataset (MDIW-13) for script identification, including printed and handwritten
18 documents for free distribution, is introduced in this paper. The handwritten part was collected
19 from letters or notes developed by volunteers living in the native zones where scripts were
20 gathered. These volunteers scanned their documents and sent them in by e-mail. The printed
21 samples were obtained from local newspapers and magazines and contain different fonts and
22 sizes and cursive and bold text. The printed documents were scanned at 300dpi.
23

24 Because the database targeted script identification tasks, the document background was
25 converted to white, and the text ink equalized to avoid watermarks due to the local paper or ink
26 textures, which could bias the results of a script identifier. This procedure was manually
27 monitored.
28

29 MDIW-13 allows experiments with script identification at different levels (e.g., document,
30 lines, and words). To this aim, the lines of each document were extracted from the documents
31 and the words from the lines.
32

33 Three benchmarks were conducted. The first one relies on local descriptors such as LBP and
34 Quad-Tree histograms with an SVM. The second one is based on Dense Multi-Block LBPs,
35 and produces excellent results due to their multi-scale and denser spatial description. The third
36 benchmark is based on two Deep Neural Network architectures. The benchmark includes
37 results at the document, line, and word levels, in addition to providing results at the handwritten
38 and printed levels. Finally, they give results of a script identifier independent of the handwritten
39 or printed text level at play.
40

41 It is expected that this new multi-script database will elicit new script identifiers, open the
42 door to developing new problems like challenges in writer dependent or independent script
43 identification challenges with the handwritten part of the dataset, artistic multi-character script
44 identification [40], or advanced algorithms for segmenting handwritten and printed-based
45 images and allow new insights into script identification. The different scenarios in the present
46 study, including handwritten and printed samples, reveal numerous challenges. The results
47 reported for the three benchmarks could serve as a baseline for further research in script
48 identification.
49

50 Future work with this database might include but is not limited to: i) the analysis of hybrid
51 models based on both statistical approaches and deep features; ii) the use of novel architectures
52 (e.g., CNN-LSTM, VAE) to incorporate context in the learning process of visual features; iii)
53 the application of domain adaptation techniques to employ pre-trained models that take
54 advantages of embedding spaces learned from similar domains (e.g., text classification).
55
56
57
58
59
60
61
62
63
64
65

ANNEXES

TABLE A.1
DATABASE STATISTICS AT DOCUMENT LEVEL

Script abrev	Handwritten						Printed					
	NumDoc	NumPix	AvgNumPix	StdNumPix	MinNumPix	MaxNumPix	NumDoc	NumPix	AvgNumPix	StdNumPix	MinNumPix	MaxNumPix
Arab	48	16364808	340934	140942	24741	692100	51	7673662	150464	79869	53637	365978
Ban	67	57354267	856034	258275	269796	1408974	51	3527860	69174	32182	15288	147683
Guj	3	1112702	370901	26643	346901	399570	32	2798190	87443	65878	23870	390789
Gurm	6	3190761	531794	304299	21977	818942	115	9653569	83944	76390	21154	476005
Hind	21	4078695	194224	180115	9463	526492	47	2887991	61447	44688	13356	214140
Jap	20	9366326	468316	136807	292364	724561	80	2367889	29599	13560	9069	71639
Kan	15	5676355	378424	284863	160551	864733	53	3170929	59829	33427	14487	192797
Mal	12	1952046	162671	157549	25357	457572	70	4273222	61046	35702	12074	198668
Ori	50	45562745	911255	260843	319114	1416357	42	3338941	79499	94056	10581	483419
Rom	90	22377054	248634	82037	59977	490772	56	11527272	205844	106145	56905	478682
Tam	14	9345399	667529	130809	435632	870280	46	1075869	23388	18041	3090	84282
Tel	10	9165463	916546	633586	236418	1965304	49	3181893	64937	45549	14928	232850
Tha	26	14004980	538653	102752	342289	685656	61	4402236	72168	61943	24270	445787
Total	382	199551601	506609	207655	9463	1965304	753	59879523	80675	54418	3090	483419

Numdoc: Number of documents. NumPix: Total number of pixels in the documents. AvgNumPix: Averaged number of pixels per document.
StdNumPix: Standard deviation of the number of pixels per document. MinNumPix: Minimum number of pixels in a document. MaxNumPix: Maximum number of pixels in a document

TABLE A.2
DATABASE STATISTICS AT LINE LEVEL

Script abrev	Handwritten						Printed					
	NumLines	NumPix	AvgNumPix	StdNumPix	MinNumPix	MaxNumPix	NumLines	NumPix	AvgNumPix	StdNumPix	MinNumPix	MaxNumPix
Arab	621	13276894	21380	9549	2887	98922	1082	7336656	6781	1854	1766	11895
Ban	1486	51832253	34880	8973	5590	63786	466	3549672	7617	5202	2336	70654
Guj	41	302810	7386	2777	4031	13424	384	4464622	11627	20822	1916	191531
Gurm	111	1368759	12331	4631	1673	19407	1062	9461641	8909	9475	2453	34604
Hind	230	1858972	8082	4542	1106	20159	397	3510591	8843	7755	2344	80344
Jap	121	968815	8007	5076	1735	29604	559	2215839	3964	991	1311	10639
Kan	377	5105947	13544	5223	2834	29903	582	3933958	6759	10509	2012	190604
Mal	211	2398611	11368	5075	1849	22886	706	3967304	5619	1895	1181	11749
Ori	1136	41062961	36147	8607	6875	66079	548	3163802	5773	2921	2447	43399
Rom	750	18868245	25158	6906	7916	46564	961	10348478	10768	3423	2259	15838
Tam	276	3553407	12875	3947	2720	24200	301	2193811	7288	2958	977	20873
Tel	154	2283067	14825	5947	2781	25639	483	3766077	7797	9809	2065	134336
Tha	473	6658573	14077	4989	2886	25598	461	4288718	9303	2487	3608	18001
Total	5987	149539314	16928	5865	1106	98922	7992	62201169	7773	6162	977	191531

NumLines: Number of lines. NumPix: Total number of pixels in the lines. AvgNumPix: Averaged number of pixels per line.
StdNumPix: Standard deviation of the number of pixels per line. MinNumPix: Minimum number of pixels in a line. MaxNumPix: Maximum number of pixels in a line

TABLE A.3
DATABASE STATISTICS AT WORD LEVEL

Script abrev	Handwritten						Printed					
	NumWords	NumPix	AvgNumPix	StdNumPix	MinNumPix	MaxNumPix	NumWords	NumPix	AvgNumPix	StdNumPix	MinNumPix	MaxNumPix
Arab	3940	13464275	3417	742	2233	7363	6202	6356966	1025	310	373	2833
Ban	9320	44844887	4812	2061	1239	21767	2557	3364773	1316	1273	389	42379
Guj	181	259737	1435	622	349	3321	2211	4151893	1878	3607	379	56110
Gurm	700	1346638	1924	884	529	6184	9104	8123326	892	556	155	4233
Hind	1457	1317882	905	579	204	5087	2782	3157311	1135	1556	333	33827
Jap	441	1084912	2460	1721	536	14947	1814	1770894	976	326	342	2545
Kan	1995	4809571	2411	1201	501	7576	2157	3550616	1646	2565	442	61944
Mal	719	2410708	3353	1808	572	11309	4320	3425423	793	283	333	2451
Ori	7847	38539556	4911	2210	1480	20991	2309	2988126	1294	791	395	13818
Rom	4308	16591698	3851	2000	758	16830	7627	9692418	1271	690	338	4687
Tam	1430	3443374	2408	1115	619	8534	2118	7201309	3400	3099	353	33514
Tel	801	2036423	2542	1282	448	8404	2126	3654671	1719	2269	371	42535
Tha	4472	5914351	1323	730	348	6846	3717	3948106	1062	470	322	3345
Total	37611	136064012	2750	1304	204	21767	49044	61385832	1416	1369	155	61944

NumWords: Number of words. NumPix: Total number of pixels in the words. AvgNumPix: Averaged number of pixels per word.
StdNumPix: Standard deviation of the number of pixels per word. MinNumPix: Minimum number of pixels in a word. MaxNumPix: Maximum number of pixels in a word

TABLE A.4
TRAINING STATISTICS AT DOCUMENT LEVEL

Script abrev	Handwritten						Printed					
	NumDoc	NumPix	TrainDoc	%TrainDoc	NumTrainPix	%NumTrainPix	NumDoc	NumPix	TrainDoc	%TrainDoc	NumTrainPix	%NumTrainPix
Arab	48	16364808	5	10,42%	2420784	14,79%	51	7673662	14	27,45%	2117246	27,59%
Ban	67	57354267	3	4,48%	3120881	5,44%	51	3527860	27	52,94%	2018089	57,20%
Guj	3	1112702	2	66,67%	765801	68,82%	32	2798190	22	68,75%	2074532	74,14%
Gurm	6	3190761	4	66,67%	2471223	77,45%	115	9653569	39	33,91%	2044016	21,17%
Hind	21	4078695	15	71,43%	2010846	49,30%	47	2887991	33	70,21%	2107547	72,98%
Jap	20	9366326	4	20,00%	2101719	22,44%	80	2367889	64	80,00%	1906104	80,50%
Kan	15	5676355	3	20,00%	2169454	38,22%	53	3170929	38	71,70%	2025503	63,88%
Mal	12	1952046	9	75,00%	1389695	71,19%	70	4273222	26	37,14%	2010067	47,04%
Ori	50	45562745	3	6,00%	2559961	5,62%	42	3338941	25	59,52%	2279637	68,27%
Rom	90	22377054	9	10,00%	2060441	9,21%	56	11527272	14	25,00%	2241415	19,44%
Tam	14	9345399	3	21,43%	2277994	24,38%	46	1075869	36	78,26%	910447	84,62%
Tel	10	9165463	3	30,00%	2589472	28,25%	49	3181893	32	65,31%	2041792	64,17%
Tha	26	14004980	4	15,38%	2288212	16,34%	61	4402236	27	44,26%	2204803	50,08%
Total	382	199551601	67	17,54%	28226483	14,14%	753	59879523	397	52,72%	25981198	43,39%

Numdoc: Number of documents. NumPix: Total number of pixels in the documents. TrainDoc: Number of documents in the training set
%TrainDoc: Percentage of documents in the training. NumTrainPix: Number of pixels in the training. %NumTrainPix: Percentage of pixels in the training

TABLE A.5
TRAINING STATISTICS AT LINE LEVEL

Script abrev	Handwritten						Printed					
	NumLines	NumPix	TrainLines	%TrainLines	NumTrainPix	%NumTrainPix	NumLines	NumPix	TrainLines	%TrainLines	NumTrainPix	%NumTrainPix
Arab	621	13276894	88	14,17%	2010497	15,14%	1082	7336656	256	23,66%	2005281	27,33%
Ban	1486	51832253	55	3,70%	2026720	3,91%	466	3549672	234	50,21%	2000904	56,37%
Guj	41	302810	32	78,05%	260126	85,90%	384	4464622	190	49,48%	2002409	44,85%
Gurm	111	1368759	88	79,28%	1121767	81,96%	1062	9461641	468	44,07%	2004257	21,18%
Hind	230	1858972	184	80,00%	1489073	80,10%	397	3510591	215	54,16%	2006034	57,14%
Jap	121	968815	96	79,34%	821819	84,83%	559	2215839	447	79,96%	1796251	81,06%
Kan	377	5105947	122	32,36%	2002821	39,23%	582	3933958	302	51,89%	2003321	50,92%
Mal	211	2398611	168	79,62%	1888048	78,71%	706	3967304	314	44,48%	2003869	50,51%
Ori	1136	41062961	49	4,31%	2030372	4,94%	548	3163802	348	63,50%	2005057	63,37%
Rom	750	18868245	83	11,07%	2001798	10,61%	961	10348478	244	25,39%	2009359	19,42%
Tam	276	3553407	150	54,35%	2004029	56,40%	301	2193811	240	79,73%	1697694	77,39%
Tel	154	2283067	123	79,87%	1700793	74,50%	483	3766077	264	54,66%	2002136	53,16%
Tha	473	6658573	158	33,40%	2018174	30,31%	461	4288718	194	42,08%	2003650	46,72%
Total	5987	149539314	1396	23,32%	21376037	14,29%	7992	62201169	3716	46,50%	25540222	41,06%

NumLines: Number of lines. NumPix: Total number of pixels in the lines. TrainLines: Number of lines in the training set
%TrainLines: Percentage of lines in the training. NumTrainPix: Number of pixels in the training. %NumTrainPix: Percentage of pixels in the training

TABLE A.6
TRAINING STATISTICS AT WORD LEVEL

Script abrev	Handwritten						Printed					
	NumWords	NumPix	TrainWords	%TrainWords	NumTrainPix	%NumTrainPix	NumWords	NumPix	TrainWords	%TrainWords	NumTrainPix	%NumTrainPix
Arab	3940	13464275	570	14,47%	2000893	14,86%	6202	6356966	1996	32,18%	2001192	31,48%
Ban	9320	44844887	401	4,30%	2003873	4,47%	2557	3364773	1608	62,89%	2000563	59,46%
Guj	181	259737	144	79,56%	224064	86,27%	2211	4151893	1229	55,59%	2001494	48,21%
Gurm	700	1346638	560	80,00%	1103880	81,97%	9104	8123326	3629	39,86%	2000388	24,63%
Hind	1457	1317882	1165	79,96%	996000	75,58%	2782	3157311	1706	61,32%	2000318	63,36%
Jap	441	1084912	352	79,82%	928975	85,63%	1814	1770894	1451	79,99%	1420649	80,22%
Kan	1995	4809571	872	43,71%	2000559	41,60%	2157	3550616	1183	54,84%	2000213	56,33%
Mal	719	2410708	575	79,97%	1870088	77,57%	4320	3425423	2370	54,86%	2000079	58,39%
Ori	7847	38539556	333	4,24%	2001919	5,19%	2309	2988126	1660	71,89%	2000920	66,96%
Rom	4308	16591698	558	12,95%	2002681	12,07%	7627	9692418	1574	20,64%	2000076	20,64%
Tam	1430	3443374	873	61,05%	2001245	58,12%	2118	7201309	451	21,29%	2011290	27,93%
Tel	801	2036423	640	79,90%	1511017	74,20%	2126	3654671	1261	59,31%	2000984	54,75%
Tha	4472	5914351	1828	40,88%	2000091	33,82%	3717	3948106	1856	49,93%	2000011	50,66%
Total	37611	136064012	8871	23,59%	20645285	15,17%	49044	61385832	21974	44,80%	25438177	41,44%

NumWords: Number of words. NumPix: Total number of pixels in the words. TrainWords: Number of words in the training set
%TrainWords: Percentage of words in the training. NumTrainPix: Number of pixels in the training. %NumTrainPix: Percentage of pixels in the training

REFERENCES

1. Narang SR, Jindal MK, Kumar M (2019) Drop flow method: an iterative algorithm for complete segmentation of Devanagari ancient manuscripts. *Multimed Tools Appl* 78:23255–23280. <https://doi.org/10.1007/s11042-019-7620-6>
2. Ghosh D, Dube T, Shivaprasad AP (2010) Script Recognition—A Review. *IEEE Trans Pattern Anal Mach Intell* 32:2142–2161. <https://doi.org/10.1109/TPAMI.2010.30>
3. Ubul K, Tursun G, Aysa A, et al (2017) Script Identification of Multi-Script Documents: a Survey. *IEEE Access* 1–1. <https://doi.org/10.1109/ACCESS.2017.2689159>
4. Obaidullah SM, Santosh KC, Das N, et al (2018) Handwritten Indic Script Identification in Multi-Script Document Images: A Survey. *Int J Pattern Recognit Artif Intell* 32:1856012. <https://doi.org/10.1142/S0218001418560128>
5. Obaidullah SM, Santosh KC, Halder C, et al (2019) Automatic Indic script identification from handwritten documents: page, block, line and word-level approach. *Int J Mach Learn Cybern* 10:87–106. <https://doi.org/10.1007/s13042-017-0702-8>
6. Pal U, Chaudhuri BB (2004) Indian script character recognition: a survey. *Pattern Recognit* 37:1887–1899. <https://doi.org/10.1016/j.patcog.2004.02.003>
7. Ferrer MA, Morales A, Pal U (2013) LBP Based Line-Wise Script Identification. In: 2013 12th International Conference on Document Analysis and Recognition. IEEE, pp 369–373
8. Ferrer MA, Morales A, Rodriguez N, Pal U (2014) Multiple Training - One Test Methodology for Handwritten Word-Script Identification. In: 2014 14th International Conference on Frontiers in Handwriting Recognition. IEEE, pp 754–759
9. Sharma N, Pal U, Blumenstein M (2014) A study on word-level multi-script identification from video frames. In: International Joint Conference on Neural Networks. IEEE, pp 1827–1833
10. Shi B, Bai X, Yao C (2016) Script identification in the wild via discriminative convolutional neural network. *Pattern Recognit* 52:448–458. <https://doi.org/10.1016/j.patcog.2015.11.005>
11. Gomez L, Nicolaou A, Karatzas D (2017) Improving patch-based scene text script identification with ensembles of conjoined networks. *Pattern Recognit* 67:85–96. <https://doi.org/10.1016/j.patcog.2017.01.032>
12. Feng Z, Yang Z, Jin L, et al (2017) Robust shared feature learning for script and handwritten/machine-printed identification. *Pattern Recognit Lett* 100:6–13. <https://doi.org/10.1016/j.patrec.2017.09.016>
13. Ahmad R, Naz S, Afzal MZ, et al (2017) KHATT: A Deep Learning Benchmark on Arabic Script. In: 14th IAPR International Conference on Document Analysis and Recognition (ICDAR). IEEE, pp 10–14
14. Tripathi R, Gill A, Tripathi R (2017) Recurrent neural networks based Indic word-wise script identification using character-wise training. *arXiv Prepr arXiv170903209*
15. Ukil S, Ghosh S, Obaidullah SM, et al (2019) Improved word-level handwritten Indic script identification by integrating small convolutional neural networks. *Neural Comput Appl*. <https://doi.org/10.1007/s00521-019-04111-1>
16. Obaidullah SM, Bose A, Mukherjee H, et al (2018) Extreme learning machine for handwritten Indic script identification in multiscript documents. *J Electron Imaging* 27:1. <https://doi.org/10.1117/1.JEI.27.5.051214>
17. Mäenpää T, Pietikäinen M (2005) Texture Analysis with Local Binary Patterns. In: *Handbook of Pattern Recognition and Computer Vision*. WORLD SCIENTIFIC, pp 197–216
18. Serdouk Y, Nemmour H, Chibani Y (2017) Handwritten signature verification using the quad-tree histogram of templates and a Support Vector-based artificial immune classification. *Image Vis Comput* 66:26–35. <https://doi.org/10.1016/j.imavis.2017.08.004>
19. Paris S, Gloti H (2010) Pyramidal Multi-level Features for the Robot Vision@ICPR 2010 Challenge. In: 20th International Conference on Pattern Recognition. IEEE, pp 2949–2952
20. Halder C, Obaidullah SM, Santosh KC, Roy K (2018) Content Independent Writer Identification on Bangla Script: A Document Level Approach. *Int J Pattern Recognit Artif Intell* 32:1856011. <https://doi.org/10.1142/S0218001418560116>
21. Brunessaux S, Giroux P, Grilheres B, et al (2014) The Maurdor Project: Improving Automatic Processing of Digital Documents. In: 2014 11th IAPR International Workshop on

- 1
2
3
4
5 Document Analysis Systems. IEEE, pp 349–354
- 6 22. Djeddi C, Gattal A, Souici-Meslati L, et al (2014) LAMIS-MSHD: A Multi-script Offline
7 Handwriting Database. In: 14th International Conference on Frontiers in Handwriting
8 Recognition. IEEE, pp 93–97
- 9 23. Maadeed S Al, Ayouby W, Hassaine A, Aljaam JM (2012) QUWI: An Arabic and English
10 Handwriting Dataset for Offline Writer Identification. In: International Conference on
11 Frontiers in Handwriting Recognition. IEEE, pp 746–751
- 12 24. Jaiem FK, Kanoun S, Khemakhem M, et al (2013) Database for Arabic Printed Text
13 Recognition Research. In: Petrosino A (ed) Image Analysis and Processing -- ICIAP 2013.
14 Springer Berlin Heidelberg, Berlin, Heidelberg, pp 251–259
- 15 25. Singh PK, Sarkar R, Das N, et al (2018) Benchmark databases of handwritten Bangla-Roman
16 and Devanagari-Roman mixed-script document images. *Multimed Tools Appl* 77:8441–
17 8473. <https://doi.org/10.1007/s11042-017-4745-3>
- 18 26. Inunganbi S, Choudhary P, Manglem K (2020) Meitei Mayek handwritten dataset:
19 compilation, segmentation, and character recognition. *Vis Comput.*
20 <https://doi.org/10.1007/s00371-020-01799-4>
- 21 27. Shi B, Yao C, Zhang C, et al (2015) Automatic script identification in the wild. In: 13th
22 International Conference on Document Analysis and Recognition (ICDAR). IEEE, pp 531–
23 535
- 24 28. Obaidullah SM, Halder C, Santosh KC, et al (2018) PHDIndic_11: page-level handwritten
25 document image dataset of 11 official Indic scripts for script identification. *Multimed Tools*
26 *Appl* 77:1643–1678. <https://doi.org/10.1007/s11042-017-4373-y>
- 27 29. Martin U-V, Bunke H The IAM-database: an English sentence database for offline
28 handwriting recognition. *Int J Doc Anal Recognit* 5:39–46
- 29 30. Hung C-S, Ruan S-J (2016) Efficient adaptive thresholding algorithm for in-homogeneous
30 document background removal. *Multimed Tools Appl* 75:1243–1259.
31 <https://doi.org/10.1007/s11042-014-2366-7>
- 32 31. Ferrer MA, Diaz-Cabrera M, Morales A (2015) Static Signature Synthesis: A Neuromotor
33 Inspired Approach for Biometrics. *IEEE Trans Pattern Anal Mach Intell* 37:667–680.
34 <https://doi.org/10.1109/TPAMI.2014.2343981>
- 35 32. Franke K, Rose S Ink-Deposition Model: The Relation of Writing and Ink Deposition
36 Processes. In: 9th International Workshop on Frontiers in Handwriting Recognition. IEEE,
37 pp 173–178
- 38 33. Suykens AK, Van Gestel T, De Brabanter J (2002) Least Squares Support Vector Machines.
39 World Scientific Publishers, Singapore
- 40 34. Chan C-H, Kittler J, Messer K (2007) Multi-scale Local Binary Pattern Histograms for Face
41 Recognition. In: Lee S-W, Li SZ (eds) *Advances in Biometrics*. Springer Berlin Heidelberg,
42 Berlin, Heidelberg, pp 809–818
- 43 35. Simonyan K, Zisserman A (2014) Very Deep Convolutional Networks for Large-Scale
44 Image Recognition. <http://arxiv.org/abs/1409.1556>
- 45 36. He K, Zhang X, Ren S, Sun J (2015) Deep Residual Learning for Image Recognition.
46 <http://arxiv.org/abs/1512.03385>
- 47 37. Conneau A, Schwenk H, Barrault L, Lecun Y (2016) Very Deep Convolutional Networks for
48 Text Classification. <http://arxiv.org/abs/1606.01781>
- 49 38. Bakkali S, Ming Z, Coustaty M, Rusinol M (2020) Visual and Textual Deep Feature Fusion
50 for Document Image Classification. In: 2020 IEEE/CVF Conference on Computer Vision
51 and Pattern Recognition Workshops (CVPRW). IEEE, pp 2394–2403
- 52 39. Obaidullah SK, Santosh KC, Halder C, et al (2017) Word-Level Multi-Script Indic
53 Document Image Dataset and Baseline Results on Script Identification. *Int J Comput Vis*
54 *Image Process* 7:81–94. <https://doi.org/10.4018/IJCVIP.2017040106>
- 55 40. Ghosh M, Obaidullah SM, Santosh KC, et al (2018) Artistic Multi-character Script
56 Identification Using Iterative Isotropic Dilation Algorithm. In: International Conference on
57 Recent Trends in Image Processing and Pattern Recognition, Springer, Singapore. pp 49–62
- 58 41. Obaidullah SM, Halder C, Das N, Roy K (2015) A Corpus of Word-Level Offline
59 Handwritten Numeral Images from Official Indic Scripts. In: Proceedings of the
60
61
62
63
64
65

1
2
3
4
5
6
7
8
9
10
11
12
13
14
15
16
17
18
19
20
21
22
23
24
25
26
27
28
29
30
31
32
33
34
35
36
37
38
39
40
41
42
43
44
45
46
47
48
49
50
51
52
53
54
55
56
57
58
59
60
61
62
63
64
65

42. International Conference on Computer and Communication Technologies., pp 703–711
Alaei A, Pal U, Nagabhushan P (2012) Dataset and Groundtruth for Handwritten Text in
Four Different Scripts. Int J Pattern Recognit Artif Intell 26:1253001.
<https://doi.org/10.1142/S0218001412530011>