

# Internet-of-Things based Smart Home Automation System using Android Phone

Salman Iqbal<sup>1</sup>, Zubair Sharif<sup>1,2</sup>, Malik Ali Shahid<sup>1</sup>, and Muhammad Zahid Abbas<sup>1</sup>

<sup>1</sup> Department of Computer Sciences, COMSATS University Islamabad, Vehari Campus, Pakistan

<sup>2</sup> Department of Computer and Information Sciences (CIS), Universiti Teknologi PETRONAS (UTP), Perak, Malaysia

Correspondence Author: Zubair Sharif (zbrsharif@gmail.com)

Received October 26, 2021; Revised November 20, 2021; Accepted November 29, 2021

## Abstract

A smart home automation system can be greatly advantageous for energy saving and management where it not only helps to save money but can be highly beneficial for the environment. It offers optimum consumption of the home resources but also leads to higher comfort and conveniences for the users and residents. Further integration of Internet of Things (IoTs) services by embedding intelligence into sensors and actuators and connecting them smartly are gaining great popularity to enhance the comfort and quality of life. Thus, by considering the IoTs importance for smart homes, this paper presents a flexible and low-cost home automation system using various sensors to control and monitor commonly used home appliances and devices where IP connectivity is provided to access and manage them remotely. For this purpose, an Android-based app is developed which can be installed on any smartphone in order to monitor and control the devices from any location. The evaluation of the integrated sensors with the devices and switches shows that the system can offer great automation to achieve the idea of smart homes.

**Index Terms:** Home Automation, Smart Home, Internet of Things, Raspberry pi, Android Application.

## I. INTRODUCTION

This decade has been characterized by a tremendous interest in sensors and sensor networks. Where it is predicted that billions of devices would be connected to the internet to communicate in some fashions. Considering the recent progress of Internet of Things (IoTs), 'Insider Intelligence' expects that 64 billion devices will be connected on the planet by 2025 [1] and [2]. The major devices include, but are not limited to, smart appliances (air conditioners, refrigerators, washers, ovens etc.), safety and security systems (sensors, cameras, monitors, etc.), and other smart homes energy equipment, like actuators, thermostats, and smart lighting.

These physical devices that are being connected to the internet are helping to accelerate the development of the IoTs and further due to their importance, these are becoming a mandatory part of our lives as well. A vibrant society deals with diversified information where safe, economic, comfortable and convenient life has become ideal for every member and family. The wide range of IoT-based applications are improving our quality of lives in many ways where Home Automation (HA) is one of them. HA is an advanced way of life based on wireless sensors and other recent technologies that modifies our homes to perform different sets of tasks remotely and automatically whenever these are required. Based on the current success of IoTs and HA systems, once a dream is slowly but steadily becoming a reality. Focusing on its

worth and future demands, it is expected that the IoT market has touched \$40 billion by 2020 [3-5].

The modern houses and offices are automated through the IoTs by using the internet that can help to control the home appliances considering the environment and human presence and requirements. The user commands over the internet and other communication technologies are passed through the set of modems and other devices. Although a range of wireless sensors are already available, many manufacturers are still developing more sophisticated HA devices adequately. These devices include smart plugs, outlets, smart temperature thermostats, home energy monitors, smart vents to adjust the inside ventilation and environment. The beauty of HA is not only that it can manage and control the things remotely, e.g., through smart phone but also helps to reduce the operating costs and conserves energy. Moreover, this application can be ideal for elderly and the persons with disabilities. They can be helpful for caregivers and institutional care providers in order to offer quality of life.

### A. Major Applications of Home Automation

After the necessary discussion, here some questions arises, i.e., what are the major applications under HA where IoTs can be implemented?; more specifically, what can be automated?

In the following, some of the key applications are listed which has been discussed by researchers [6] and [7]. These applications are playing a critical role to accomplish the idea of HA:



i. Lighting:

Firstly and most common thing that comes to mind is the home lighting that can be scheduled to turn on/off. Even it is possible to adjust their intensity according to the requirements and outside environment [8].

ii. Heating, Ventilation, and Air Conditioning (HVAC):

Although, the facility to control the room thermostat remotely is already available as the manufacturers of many appliances are providing this. However, in the near future the IoTs can make a thermostat intelligent enough that it can recognize when someone is leaving or coming back to home and then accordingly these will operate the appliances. Further, it can notice or recognize the residents' certain actions e.g., sleeping routines, showering, exercising routines, so the home temperature and environment can be adjusted accordingly [9].

iii. Doors/Windows:

Doors and windows play the most critical role to isolate the inside and the outside environment, thus by controlling these entry points, the outside effect can be minimized. For example, doors should be open only when someone enters/leaves the room, the same idea can be implemented in the car garage. While windows shutters can be adjusted considering the outside light and temperature, even can be closed completely in case of raining [10].

iv. Safety/Security:

Monitoring human activities especially at the main gate and room entrances can play a vital role for the home security and can be achieved efficiently by using the IoTs. Not only security, but safety, like detection of fire, smoke, water or any unwanted material is highly important for the safety of the home residents. Based on received information the automatic safety alarms can react to minimize the loss or damage. This safety and security system can even be more helpful for the aged and handicapped peoples that can react or control the devices during any critical situation [11].

v. Lawn/Gardening:

Not only rooms and inside environment, but IoTs can make our lawns, gardens even indoor plants smarter. For example, a sensor can be placed in a plant pot or soil which can detect the level of dryness and based on that it can trigger the motor used to irrigate the plant(s) [12] and [13].

vi. Environment or Resident Specific Routines:

Other than the above-mentioned common applications, HA can reach to further levels where the devices can be controlled based on specific routines. For example, music can be on/off or even its volume can be adjusted considering the residents' routines. Similarly, morning or evening routines can be defined to adjust the windows shutters or water heater of the bathroom [14].

*B. Issues and Challenges*

Integration of various types of devices and their sub-systems especially when they belonged to different

vendors is not a simple task [15] and [16]. This can be one of the major challenges among many other factors which can lead to several issues that must be considered whenever developing a HA system. Hence, it is necessary to address and determine suitable control and processing capabilities to manage the whole system.

Firstly, the reliability of internet connectivity is a major requirement, as still its connectivity is unpredictable in many cases and regions. Further, experts should develop the system by considering the dependability of all sensors and devices. For this purpose, the collection of data and its use should be efficient enough as along as this data, personal or inside information can be leaked. Here it is important to mention that, to achieve the goal of 'connected home', many professionals like electrician, civil engineer, gasman, locksmith etc., can be involved. Hence, they need to transform their business and skills according to market demands. All these professionals not only must have complete idea about the connected devices but also consider the standardization when connecting the devices which are designed by different vendors. Considering the past, it has been seen that usually, the solutions of smart home devices come with frequent updates or patches that are not always fully reliable.

## II. EXISTING SOLUTIONS

The use of IoTs to control and monitor home appliances in smart homes is becoming a leading research area with the passage of time [17-19]. Not only for electricity saving and convenience purposes, but these applications are also becoming highly attractive for the elderly and persons with disabilities [20]. Researches based on home automated systems in order to control the home devices without any physical connections are discussed by some researchers [21]. Some of them are based on Dual Tone Modulated Frequency (DTMF) and some are using bluetooth technologies. Where DTMF has the issue of Public Switched Telephone Network (PSTN) channel for communication and the Bluetooth has the issue of short-range communication.

IoT has a crucial part known as 'Smart House' or HA, where IP address is assigned to each thing and can be observed and examined whenever needed from anywhere. For many years home appliances helped regarding light up and other simple appliances control. For converting the ideas into real world, technology is controlling smartly the home appliances [22]. HA can rule how and when a device will respond and act. It provides a fully controlled, convenient and money saving environment. Further, it can also be helpful in escaping the users from any sort of disaster and unpredicted happenings at the home. For this purpose, users can control the devices according to their desired requirements by using Bluetooth connected systems or the Android applications [23].

An IoT-based system using low cost power, solo computing platform is designed by investigators [24]. Here by using the virtual buttons and sliding switches, user can control and observe the devices at home. Even these can be operated with the help of text and voice commands. A project based on 'Arduino' and 'Android' smart phones with low Wi-Fi cost for smart home is proposed by scholars [25]. This allows the user to control

the devices of the home by using Wi-Fi. Further in this system some sensors were used to detect the motion and temperature. This system helped in minimizing the electricity bills by controlling the home appliances anytime. Moreover, this system also enhances home security by controlling the home appliances using android cell phones. Login security through eye or fingerprint can also be used in order to provide the better control. A trusted face database is used in this system to detect the intruder or false alarm [26].

A system to connect some bulbs with the help of the IoTs is proposed. Where the two advantages of this system are; the accessing and monitoring of smart homes can be done easily and the other one is helping the persons with disabilities. Further changes can be made by considering the future requirements by adding controlling units for dealing with the real time conditions. In addition, a real time system based on HA is proposed [27]. This is productive to control the commonly used home appliances with the help of sensors.

Further, in order to improve the home security, authors applied a system in which they used a camera for clicking the pictures to provide information to the owner about who entered the room [28]. Similarly, to provide the security, some security sensors were used in a system already proposed to enhance the home security and the advantage of this system is it is cost effective [29].

Using the 'RESTful' services and less cost a smart system for monitoring and controlling using the android phones is proposed by researchers [30]. The designed system provides communication and controlling between home appliances and the remote users through Wi-Fi. Further 3G or 4G can also be used to the control system if the Wi-Fi is unavailable.

Data transfer between devices and controllers is carried out using one or more communicating technologies. These are GSM, Wi-Fi, ZigBee, or Ethernet. ZigBee and Bluetooth are normally used to send and manage the data at home and to maintain communication among sensors and the CPU. These data transfer technologies are renowned for their ease of implementation and low power usage [31] and [32].

The 'Blue Tooth 4.0' protocol is used to provide communication among users and smart devices. Users can control remotely these devices with the help of their mobile phones or tablets. The only drawback with Bluetooth technology is that the device(s) can only be handled from a short distance [33-35].

To save household energy the authors presented a system, through the implementation of some sensors. For example, temperature, motion detecting, and luminance sensors are used (with the help of an algorithm) to conserve the energy from different home appliances like lights, fans, and air conditioners etc [36].

Further, authors designed a localized architecture to control the home's inside temperature and the environment automatically. The advantage of this system is that the new services can be added to their designed system [37].

### III. PROPOSED SYSTEM

Learning from the literature review, and considering all the above discussed issues, we proposed an adaptable, standalone, and low-cost home controlling and monitoring system. The system is flexible enough as the other equipment can be included depending on the user requirements. The overall structure consists of various relay modules, controllers, Raspberry Pi, and various sensors.

The list of major equipment is provided below:

- Raspberry Pi
- Air Sensor
- Light Sensor
- Smoke Detecting Sensor
- PIR (Passive Infrared Sensor)
- Hall Effect Sensor
- Android Application

The basic purpose to utilize the Passive Infrared (PIR) sensor and Hall Effect sensor is to monitor the various activities whenever these are required. These 'activity monitoring sensors' are deployed at the entrances and exits to and from the home spaces and the rooms. Further, this 'activity monitoring' can be helpful in detection and dealing with any sort of intrusion or suspicious activities.

To make these equipment operational, an android based application is developed which enhances the system functionality. The important thing about the system is that it can be customized in different ways in order to accommodate various scenarios and requirements with minimum re-coding and design.

#### A. Major System Components

The proposed system is composed of the following four major components:

1. Controller (Raspberry pi)
2. Sensors
3. Home Devices or Appliances
4. Android Application

A block diagram about the system representation is provided in Figure 1, while a general sketch regarding the equipment and its connectivity is illustrated in Figure 2. Both of these figures shows that how these components are interconnected in order to make the indoor environment smarter. Among these components, the control process starts from the android application (discussed in the Android Application Section) which is the main point from where the user can interact and control the whole system. This interface, at one side interacts with the user/resident while at the same time it communicates with a microcontroller (i.e., Raspberry Pi) which is installed behind the wall board. This microcontroller is the centralized component that interacts with both, installed sensors and home appliances. It attains environment parameters from the sensors like temperature, light intensity, smoke etc. as input to know the current indoor conditions. Based on the received values and to achieve the required conditions,

Raspberry Pi will send instructions to the appliances like AC, fan even window curtains, while various power relays are included to switch ON/OFF the devices for this purpose.

Other than monitoring and controlling the devices and environment, the system is also capable to inform the owner(s) on their mobile phone via SMS or call to alert them, if necessary.

Same way it can be followed whenever any kind of unauthorized movement is detected.

A complete flow chart of the android application along with available options and how it navigates from screen to screen is available in Figure 3.

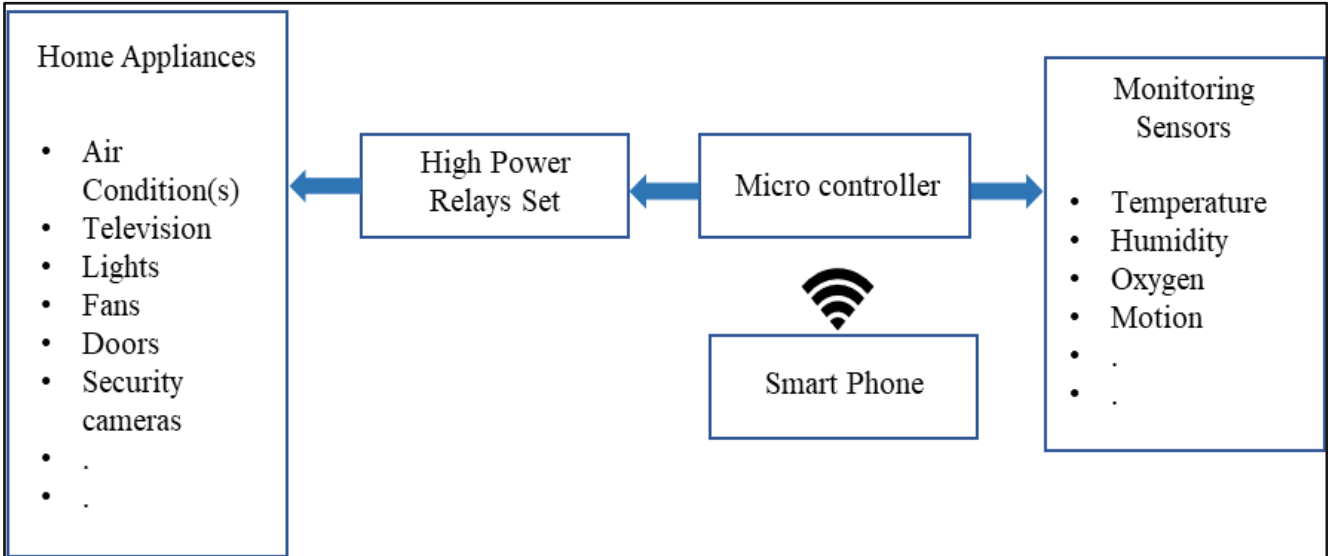

Figure 1: Block Diagram of Proposed System

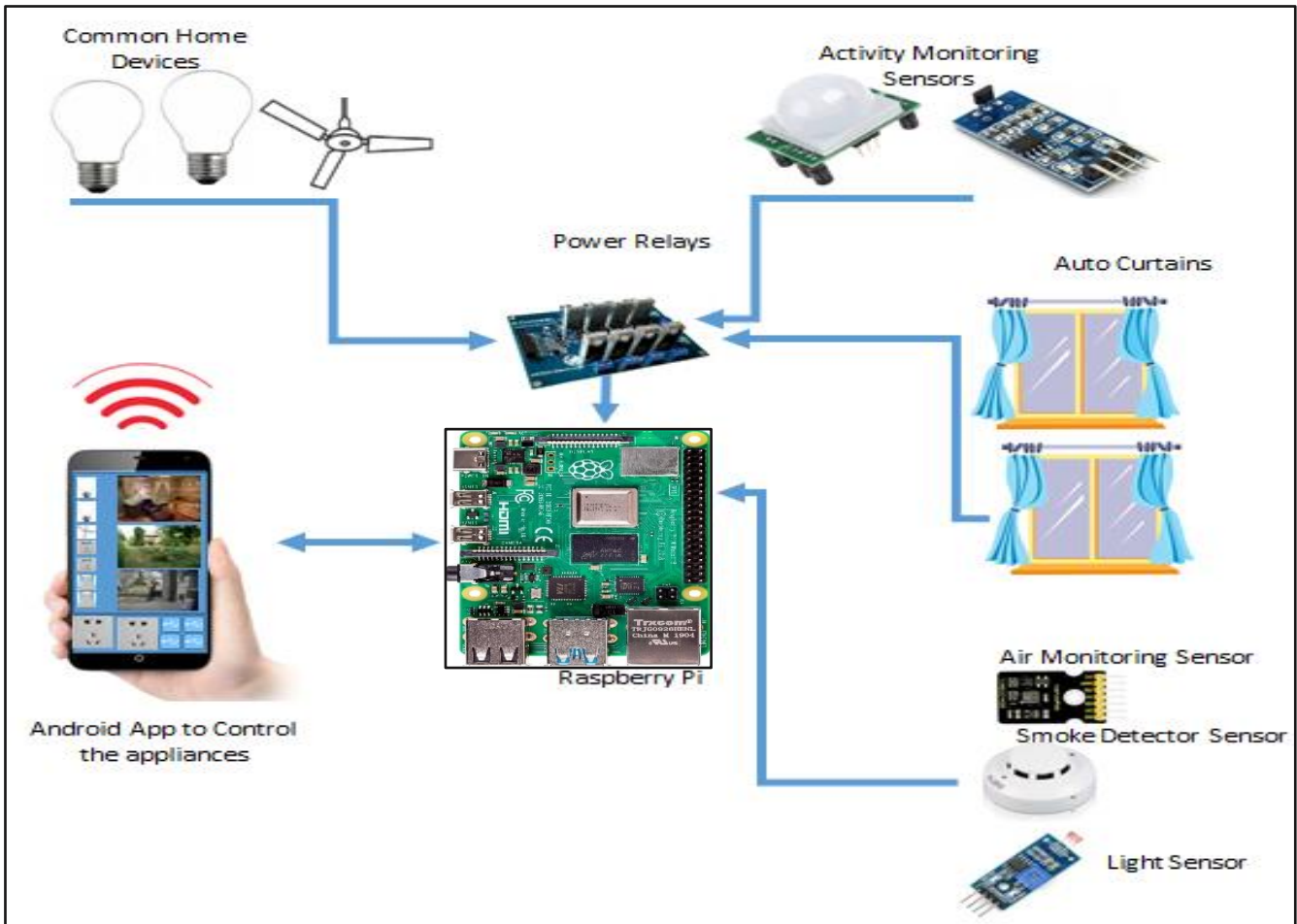

Figure 2: Possible Sketch of Equipment used and Connected for HA

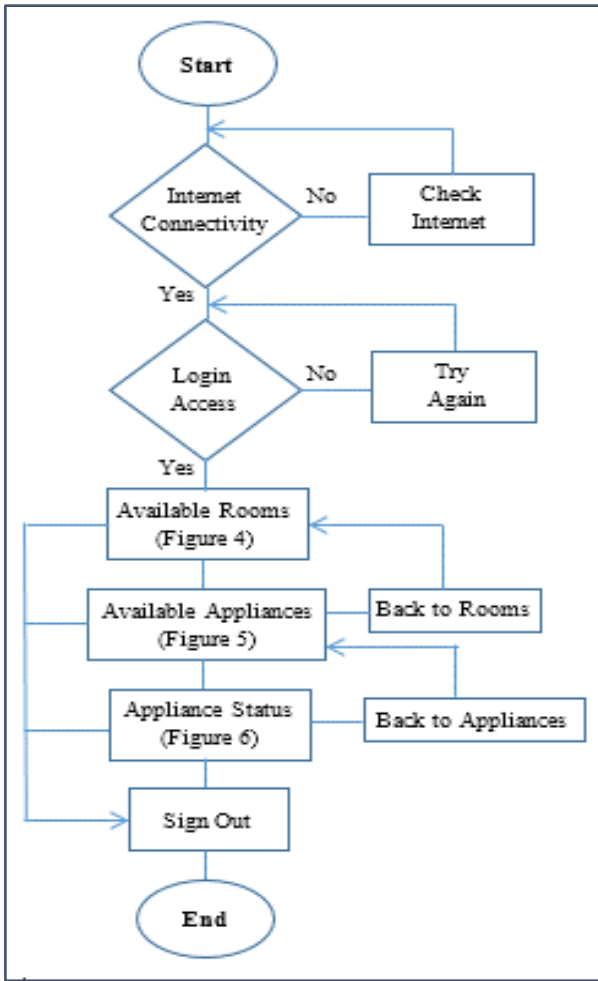

Figure 3: Flow Chart for the Developed System considering the Android Application

#### IV. RESULTS AND DISCUSSION

##### A. Android Application

When the user or resident selects the application, it first asks to authenticate. If the user is authorized, then he/she will be navigated to the main screen as shown in Figure 4. On this screen, all the rooms are available where the devices are installed and can be controlled from here. Hence a user can select any desired room. After selecting the desired room, all the devices of that room will be shown on the next screen as shown in Figure 5. While the user can select any device from here along with all actions that are available like, fan speed or AC temperature etc. For this, some devices carry more options like operating intensity along room environment e.g., current temperature while for few others have simple options like ON and OFF. For instance, when the user selects the light 1 then the next screen will appear as depicted in Figure 6. Here user can switch ON/OFF the light 1. Further, considering the relevant information like time, the system can ON/OFF the lights automatically at a specific time unless we disable this functionality. Other than this, the activity sensors can be helpful to switch ON/OFF the lights during any period of day or night. The retrieved information from activity sensors will also be helpful to control the lighting systems.



Figure 4: Main Screen of the Developed Application

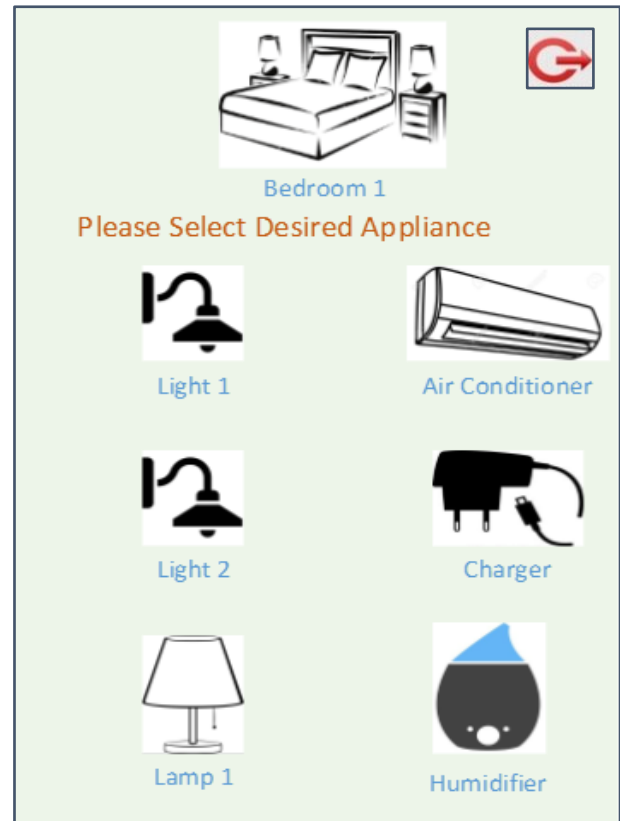
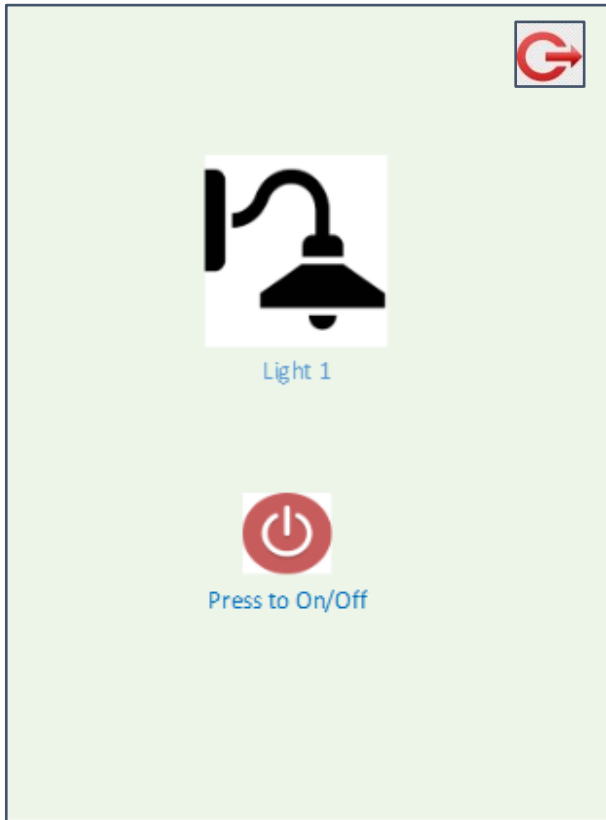

Figure 5: Various Options of Devices in a Selected Room





**Figure 6:** Possible Options to Control a Specific Device/Appliance

### B. Challenges During Application Development

It is common that home devices or appliances almost at every home are not only of several types but made by multiple manufacturers. Now, there should be one application but not many to deal with all of them. Based on the fact, developing an application for HA system comes not only with a range of technical issues but must consider security challenges as well. It must be remembered that always a risk factor is involved as whenever sending or sharing the home's inside information on the internet. A careful assessment of all the technicalities of appliances as well as security concerns is of great significance as it can share your status and presence to some unwanted or unauthorized hands, e.g., how many thermostats are at your home, when you are usually at home or away etc. Thus our developed single application efficiently deals with the mentioned situations.

### C. What is Achieved

- Smart use of home appliances.
- There is no need of replacement of the existing appliances because changes are only made in the control unit.
- Energy saving, as appliances are used whenever required and how much required ultimately reduces the electricity cost.
- Detection of smoke or fire.
- The activity monitoring sensors can be highly helpful to maintain the home or building security.
- The system can alert the house owner or residents about any unwanted activity.

- Environment friendly

## V. CONCLUSION

The developed system utilizes the IoT-based communication features to connect and control the home appliances remotely. For this purpose, different components like sensors, raspberry pi, and commonly used home appliances are considered. As the designed system is user friendly and makes the home environment more comfortable. An android based application is developed to make the system functional, by using that a user can access and control all home appliances through the touchscreen commands. The system and application are adaptable (flexible) enough as the modifications can be made like new appliances, features or new rooms can be added/remove according to the residents' requirements.

## VI. FUTURE RECOMMENDATION

As a future work, we are planning to extend the working area and features of the system, as well as adding more options in the application. After introducing new features, the system will cover other than rooms like lawn and garden, which facility is not available yet.

## Acknowledgment

The authors would like to thank COMSATS University Islamabad, Vehari Campus for all the support provided to accomplish this research work.

## Authors Contributions

Zubair Sharif contribution to this study was the concept, and correspondance. Salman Iqbal performed, data collection, supervision and methodology. Malik Ali Shahid performed the data compilation and validation. Muhammad Zahid Abbas contributed in project administration, and paper writing.

## Conflict of Interest

There is no conflict of interest between all the authors.

## Data Availability Statement

The testing data is available in this paper.

## Funding

This research was supported by the Higher Education Commission (HEC), Pakistan.

## References

- [1] Yassine, A., Singh, S., Hossain, M. S., & Muhammad, G. (2019). IoT big data analytics for smart homes with fog and cloud computing. *Future Generation Computer Systems*, 91, 563-573.
- [2] Li, M., Gu, W., Chen, W., He, Y., Wu, Y., & Zhang, Y. (2018). Smart home: architecture, technologies and systems. *Procedia computer science*, 131, 393-400.
- [3] Geraldo Filho, P. R., Villas, L. A., Gonçalves, V. P., Pessin, G., Loureiro, A. A., & Ueyama, J. (2019). Energy-efficient smart home systems: Infrastructure and decision-making process. *Internet of Things*, 5, 153-167.
- [4] Hui, T. K., Sherratt, R. S., & Sánchez, D. D. (2017). Major requirements for building Smart Homes in Smart Cities based on

- Internet of Things technologies. *Future Generation Computer Systems*, 76, 358-369.
- [5] Sharif, Z., Jung, L. T., Razzak, I., & Alazab, M. (2021). Adaptive and Priority-based Resource Allocation for Efficient Resources Utilization in Mobile Edge Computing. *IEEE Internet of Things Journal*.
- [6] Abro, G. E. M., Shaikh, S. A., Soomro, S., Abid, G., Kumar, K., & Ahmed, F. (2018, August). Prototyping IOT Based Smart Wearable Jacket Design for Securing the Life of Coal Miners. In *2018 International Conference on Computing, Electronics & Communications Engineering (iCCECE)* (pp. 134-137). IEEE.
- [7] Ahmed, S. U., Khalid, H., Abro, G. E. M., & Farooqui, M. Z. Intelligent Skin Doctor Using Deep Learning.
- [8] Sivagami, P., & Swaroopan, N. J. (2020). Smart methodology for performance improvement of energy sources for home application. *Microprocessors and Microsystems*, 74, 103042.
- [9] Guo, X., Shen, Z., Zhang, Y., & Wu, T. (2019). Review on the application of artificial intelligence in smart homes. *Smart Cities*, 2(3), 402-420.
- [10] Vishwakarma, S. K., Upadhyaya, P., Kumari, B., & Mishra, A. K. (2019, April). Smart energy efficient home automation system using iot. In *2019 4th international conference on internet of things: Smart innovation and usages (IoT-SIU)* (pp. 1-4). IEEE.
- [11] Mocrii, D., Chen, Y., & Musilek, P. (2018). IoT-based smart homes: A review of system architecture, software, communications, privacy and security. *Internet of Things*, 1, 81-98.
- [12] Zaidan, A. A., Zaidan, B. B., Qahtan, M. Y., Albahri, O. S., Albahri, A. S., Alaa, M., ... & Lim, C. K. (2018). A survey on communication components for IoT-based technologies in smart homes. *Telecommunication Systems*, 69(1), 1-25.
- [13] Uddin, M. A., Ayaz, M., Mansour, A., Sharif, Z., & Razzak, I. (2021). Cloud-connected flying edge computing for smart agriculture. *Peer-to-Peer Networking and Applications*, 1-11.
- [14] Ghayvat, H., Mukhopadhyay, S., Shenjie, B., Chouhan, A., & Chen, W. (2018, May). Smart home based ambient assisted living: Recognition of anomaly in the activity of daily living for an elderly living alone. In *2018 IEEE international instrumentation and measurement technology conference (I2MTC)* (pp. 1-5). IEEE.
- [15] Hong, A., Nam, C., & Kim, S. (2020). What will be the possible barriers to consumers' adoption of smart home services?. *Telecommunications Policy*, 44(2), 101867.
- [16] Ayaz, M., Ammad-Uddin, M., Sharif, Z., Mansour, A., & Aggoune, E. H. M. (2019). Internet-of-Things (IoT)-based smart agriculture: Toward making the fields talk. *IEEE Access*, 7, 129551-129583.
- [17] Hafidh, B., Al Osman, H., Arteaga-Falconi, J. S., Dong, H., & El Saddik, A. (2017). SITE: The simple Internet of Things enabler for smart homes. *IEEE Access*, 5, 2034-2049.
- [18] Abbas, M. Z., Abu Baker, K., Ayaz, M., Mohamed, H., Tariq, M., Ahmed, A., & Faheem, M. (2018). Key factors involved in pipeline monitoring techniques using robots and WSNs: Comprehensive survey. *Journal of Pipeline Systems Engineering and Practice*, 9(2), 04018001.
- [19] Abbas, M. Z., Bakar, K. A., Ayaz, M., & Mohamed, M. H. (2018). An overview of routing techniques for road and pipeline monitoring in linear sensor networks. *Wireless Networks*, 24(6), 2133-2143.
- [20] de Oliveira, G. A. A., de Bettio, R. W., & Freire, A. P. (2016, October). Accessibility of the smart home for users with visual disabilities: an evaluation of open source mobile applications for home automation. In *Proceedings of the 15th Brazilian symposium on human factors in computing systems* (pp. 1-10).
- [21] Herrero, S. T., Nicholls, L., & Strengers, Y. (2017). Smart home technologies in everyday life: do they address key energy challenges in households?. *Current Opinion in Environmental Sustainability*, 31, 65-70.
- [22] Wu, S., Rendall, J. B., Smith, M. J., Zhu, S., Xu, J., Wang, H., ... & Qin, P. (2017). Survey on prediction algorithms in smart homes. *IEEE Internet of Things Journal*, 4(3), 636-644.
- [23] Krishna, V., & Bose. (2020). *Emerging Research in Data Engineering Systems and Computer Communications*. Springer Singapore.
- [24] Hamdan, O., Shanableh, H., Zaki, I., Al-Ali, A. R., & Shanableh, T. (2019, January). IoT-based interactive dual mode smart home automation. In *2019 IEEE international conference on consumer electronics (ICCE)* (pp. 1-2). IEEE.
- [25] Jabbar, W. A., Alsibai, M. H., Amran, N. S. S., & Mahayadin, S. K. (2018, June). Design and implementation of IoT-based automation system for smart home. In *2018 International Symposium on Networks, Computers and Communications (ISNCC)* (pp. 1-6). IEEE.
- [26] Somani, S., Solunke, P., Oke, S., Medhi, P., & Laturkar, P. P. (2018, August). IoT based smart security and home automation. In *2018 Fourth International Conference on Computing Communication Control and Automation (ICCUBEA)* (pp. 1-4). IEEE.
- [27] Baloch, W., Shanker, B., & Ghulamani, S. (2016). 2 Controlling Self-Directed Vehicle via Webpage using Raspberry Pi Lighttpd Webserver. *Sir Syed University Research Journal of Engineering & Technology*, 6(1), 4-4.
- [28] Brundha, S. M., Lakshmi, P., & Santhanalakshmi, S. (2017, August). Home automation in client-server approach with user notification along with efficient security alerting system. In *2017 International Conference On Smart Technologies For Smart Nation (SmartTechCon)* (pp. 596-601). IEEE.
- [29] Vikram, N., Harish, K. S., Nihaal, M. S., Umesh, R., & Kumar, S. A. A. (2017, January). A low cost home automation system using Wi-Fi based wireless sensor network incorporating Internet of Things (IoT). In *2017 IEEE 7th International Advance Computing Conference (IACC)* (pp. 174-178). IEEE.
- [30] Piyare, R. (2013). Internet of things: ubiquitous home control and monitoring system using android based smart phone. *International journal of Internet of Things*, 2(1), 5-11.
- [31] Al-Kuwari, A. M. A., Ortega-Sanchez, C., Sharif, A., & Potdar, V. (2011, May). User friendly smart home infrastructure: BeeHouse. In *5th IEEE International Conference on Digital Ecosystems and Technologies (IEEE DEST 2011)* (pp. 257-262). IEEE.
- [32] Al-Kuwari, M., Ramadan, A., Ismael, Y., Al-Sughair, L., Gastli, A., & Benammar, M. (2018, April). Smart-home automation using IoT-based sensing and monitoring platform. In *2018 IEEE 12th International Conference on Compatibility, Power Electronics and Power Engineering (CPE-POWERENG 2018)* (pp. 1-6). IEEE.
- [33] Singh, H., Pallagani, V., Khandelwal, V., & Venkanna, U. (2018, March). IoT based smart home automation system using sensor node. In *2018 4th International Conference on Recent Advances in Information Technology (RAIT)* (pp. 1-5). IEEE.
- [34] Kazi, R., & Tiwari, G. (2015). IoT based Interactive Industrial Home wireless system, Energy management system and embedded data acquisition system to display on web page using GPRS, SMS & E-mail alert. In *2015 International Conference on Energy Systems and Applications* (pp. 290-295). IEEE.
- [35] Ali, Z. A., & Jabeen, B. (2019). Prototyping Non-holonomic Hovercraft for Path Planning and Obstacle Avoidance. *Sir Syed University Research Journal of Engineering & Technology*, 9(1).
- [36] Lohan, V., & Singh, R. P. (2019). Home automation using internet of things. In *Advances in Data and Information Sciences* (pp. 293-301). Springer, Singapore.
- [37] Mainetti, L., Mighali, V., & Patrono, L. (2015, May). A location-aware architecture for heterogeneous building automation systems. In *2015 IFIP/IEEE International Symposium on Integrated Network Management (IM)* (pp. 1065-1070). IEEE.