

# Helping Hand for Un sighted People-Acousticsight

Abarna M, Jane Lourde Teresha A, Devisri R, Maithreyini M, V. Kumar Chinnaiyan

**Abstract**—Technology is best when it brings people together. Today technology plays a vital role in humanity. Also applied science can make the impossible possible. The proposed project aims to show equality in the safe navigation of visually impaired people just like a normal person. The project aims to help the secure guidance of humans with bad eyesight. This system support the sole in attaining the landing place, leading them across the way and alert them about the barrier that are expected in their path through the vibration and generate simulated speech output through headset. Therefore, this technology hold back them from striking the barrier. It add on value to conventional canes with barrier predicting, preventing human from accident and reducing difficulties in navigation. An ultrasonic sensor is execute to determine the distant of obstacles from the person. It is a Raspberry Pi based platform that is used to alert the person of impending obstacles. Also can create the place for all other components and it has functioning code. Here, a vibration motor is used to warn the person from the collision. Combined with the role of guiding, it also has aid preventing plan in case of emergency. The GPS is included to find the location of person and the location is sent to the person's family through the notification by means of Blynk app. Accordingly, The project convince the visually impaired people can travel alone without getting fear or accidents at the moment.

**Keywords:** Visually impaired, sensing, vibration motor, barrier prediction.

## I. INTRODUCTION

The positive thinker sees the invisible, feels the intangible, and achieves the impossible. Calm mind brings strength and self-confidence so that's important for good health. A healthy body is unavoidable to continue any function. For someone with standard health conditions, things are almost easy to people who are having a disability. They meet various problems like social, physical and mental threats. Disable people are always depends a other person to carry out their own routines. Particularly unsighted people meets many issues. It is estimated that 2850lakhs individuals are visually challenged over the globe, 390 lakhs relate to the completely loss of vision list and 2460lakhs have low eyesight over the planet. As growing technology have given many results for

**Revised Manuscript Received on September 25, 2020.**

\* Correspondence Author

**Abarna M\***, electrical and electronics engineering department, of the KPR institute of engineering and tecnology ,arasur [abarnamurugesan99@gmail.com](mailto:abarnamurugesan99@gmail.com)

**Jane Lourde Teresha** electrical and electronics engineering department, of the KPR institute of engineering and tecnology ,arasur, [janeamulraj@gmail.com](mailto:janeamulraj@gmail.com)

**Maithreyini M** , electrical and electronics engineering department, of the KPR institute of engineering and tecnology ,arasur [maithumadhavan@gmail.com](mailto:maithumadhavan@gmail.com)

**Devisri R** , , electrical and electronics engineering department, of the KPR institute of engineering and tecnology ,arasur [devisriraghunadhan@gmail.com](mailto:devisriraghunadhan@gmail.com)

blind people. About 90% of the world's visually impaired live in low-income spaces. 82% of humans living with bad eyesight are aged 50 years and above. They are meets many issues over the life span. And the major problem is getting fear of lost or collision in the street while crossing the road. For the purpose of decreasing their struggling level dependence level, that's why we proposed the system "Acoustic sight", to fulfill the basic need of visually challenged people. The objective of the proposed project is to explore the growth of navigation support for blind people. It is a node Micro Controller Unit based platform that is used to warn the person of the impending barriers. It is compact and provide info to the users about barriers through synthetic speech output.. In order to we are using the raspberry pi to find exactly what obstacle is existing and aware about the same to the user through the headset. The migration trouble of blind i.e. barrier in their way are predicted by using ultrasounds and vibrators. Asymmetrically, so as to cut back migration troubles of the people needed viewpoint. Electronic device like ultrasonic sensor and vibratory motor alertness individually. Technique which is used for sound propagation to migrate, communicate, with or predict obstacle and its send back as a biofeedback besides to this, in case of emergency regarding to the persons health or manual location, at tiny push button is put up on the system which when the button is pressed it sense a warning message together with the users location to his or her friends and families who are prefixed. During cases of emergency, it promote immediate communication to the users family without delay with the help of Blynk android software which transfers the emergency notification through the raspberry pi's modules Wi Fi module and GSM. The GPS is included to track the location users. The warning message with location is sent to the contact who are connected with the raspberry pi by means of Blynk app. Programing is done to predict the fair of the object forth coming in the way. Analytical limit for the fair between obstacles and user, if the distance is above the analytic level discontinue vibration is employed and continues vibrations for obstacles below analytic level. Therefore, the proposed system Acoustic sight secure a prominent result in supporting the visually impaired aged people who lack proper eyesight and also in the health maintenance sector, making a globe a better place to live in. [1] Humans having low vision problem will find it difficult while traveling alone on the roads to recognize what obstacles is present in front of users. This may cause a large difficulties. The smart stick uses infrared sensor to identify staircases and two ultrasonic sensors to locate somewhat present before the user.



## Helping Hand for Un sighted People-Acousticsight

Alert messages are provide and vibration motor is also stand up work by the microprocessors when an object is found on the way.[2] The difficulty level of blind people has been replaced by this smart walking canes. It uses Arduino UNO, LCD display, voltage regulator, voice repetition module and the two sensors. This smart cane has Arduino UNO and it gives accurate calculation immediately without any delay. On order to, ultrasonic sensor measured the distance between the object and smart walking canes. Infrared sensor will be used for predicting the barrier in the right and left side, which is of small range. The motive for switch IR sensor is to decrease the estimating difficulties that is come upon while using too many ultrasonic sensor. The user can attain the goal through the aid of voice repetition. [3] The acoustictactile vision system uses ultrasonic distance finder. This sixth tactile system in order to permit the user to walk through out the entrance and transmit with the body in an inherent and user-site even without sight in a friendly manner and allow the person to move around without vision. [4] An Arduino Nano based object detecting smart canes for visually challenged people, which support a blind people by identify the barriers using Ultrasonic sensors and android mobile application. It can apprise the blind person about the environment& present condition of the way where he/she is walking. [5] The electronic canes like command is used by the unsighted user. A button that can be pressed with the thumb that allows the unsighted user to send a general notification on a saved mobile number for help.

### II. PROBLEMSTATEMENT

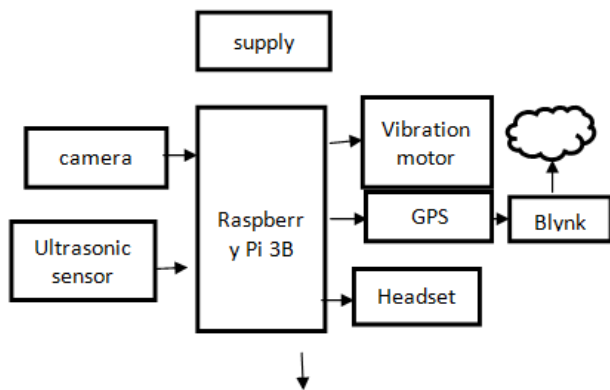

After all, the technology has succeed to a huge develop the devices helping the unsighted people hasn't grow to help the people living in median way of life. Yet experimentation is close to get the aiding devices that can be provide by everyone. The tool for the person with poor vision are expensive and the median living people can't offer such tool. So, we planned to create an reasonable and systematic tool with improvement in leading in their path. There are set of troubles come across by the visually impaired people in bringing out their routine works especially while walking alone. In this rapid world and enlarge traffic, there are many probabilities of them facing with accidents or confusing with the upcoming object present on their way. In this work the smart cane used for aiding is replaced by a tool that warn the use rof the impending object by means of vibration and synthetic speech output of obstacles present before them. In case of emergency, the tool promotes the notification

immediately and the message is sent to the friends or families along with the location through Blynk app where the person is being blocked all the sides..The projects help in the independent migration of the visually impaired person along with a backup protection that calls for the aid of the person's connection during emergency conditions due to anxious circumstances, and health problems.

### III. PROPOSED SYSTEM

The technique publish aims comes up with guidance to the unsighted people. In this tool we are using various electronic components aiming to accomplish the aiding process. The ultrasonic sensor which plays the vital role of determine the far between the object and the person. The signal from the sensor are given to the Raspberry Pi, which makes the vibrating motor to vibrate based on the distance from the object according to the program that is fed into it. The supply to the entire system is given with the help of light weight power bank. The speech output is produced through headset and it is used to let them now about the object that are present on the way by means of image processing. Image processing is a method to perform some analytical function and operating of a compute image, especially with the aim of improve the quality of image. The output that we get after the image processing is a framework or some apprise image or video. For the sake of reasonable price of the raspberry pi, it is presence used for image and video processing. The speech output is build extra precise by the use of raspberry pi which determines the what exact obstacle is present and it is let them now through the headset. When the person needs some human aid a button is put up in the tool which when pressed, sense the user location to the friend or families how are connected to the raspberr y pi. The specific feature is achieved by the use of Blynk app and GPS. Blynk app is the most popular IoT platform to connect device to the cloud, created app to control them and to handle install s at a sale is done by Blynk app and the GPS is used to track the user location during emergency. Whenever the button is pressed raspberr y pi get this to work to send the notification to the family or friends, when the person blocked all the sides or need some human support This particular features is attain by the use of GPS ULTRASONIC SENSOR---Ultrasonic sensors offer the ability t0compute the far between the obstacle and alone. It carry out this task over the use of ultrasonic waves. The ultrasonic waves or ultrasound waves are the terms used to describe elastic waves with frequencies greater than 20,000 Hertz. Some species like a Palawan swiftlet is float always inside in the darkness of river cave. They are use this methodology for the migration as they are nocturnal and flash cannot be possibly used. The same concept is recruit in these sensors where in here they support in the migration of the visually impaired. It calculate the distance between the object present on their way and the person. This is same as the function of a stereoscopic sonar that is used to determine the depth of objects undersea.





**Fig. 2. Ultrasonic Sensor.**

VIBRATION MOTOR--- Vibration motor have been around 1960s. In 1990's people were needed the vibra-call in their cell phones that is the reason they were invented the vibration motor. Especially, Pan cake vibration motors are the widely used ones as they are compact and trouble free. This type of motors are easy to be suited into all kind of system as they need exterior moving parts. It also have sticking support that would be possible to be easily fixed to any surface. They have interior H-circuitry. Here it is present as a means to alert the person ready for if the ultrasonic sensor has predicted an object within a specific distance.



**Fig. 3. Vibration Motor.**

3. GLOBAL POSITIONING SYSTEMS-- Here GPS included with the aim of detecting the location of the person, such that it can be send the notification to the user's pre-decided friends or families when the person is found in any emergency conditions. It performs on the method of trigonometry. It can detect the location from the range determine to the satellites. It measures the far between the satellite and device by transmitting the location along with the satellite at the speed of light and finally ends up when the calculation has done. Thus, the exact position is obtained.



**Fig. 4. GPS.**

4. RASPBERRY PI-- Raspberry pi 3B has various benefits like it is reasonable pricebut still works as a tiny computer. It is just like a debit card and so it is movable. It makes smooth the work and it create a principles in studyingdifferent computer languages. It can be switch PCor TV as well. It can work like a hard drive because of memory card inserted in the raspberry pi. Here raspberry pi is mainly used to find out exactly



**Fig. 5. RASPBERRY PI.**

what kind of obstacles is present based on the image from the camera. It delivers the information a headset to the user.

5. IMAGE PROCESSING –Theimage processing is a lengthy process which is illustrate by the following divisions. They are

- Detection–Notice the objects that are visible by this technique..
- Figure keenness and reconstructing - To builda wellfigure.
- Image rectifier–Look out for the image of appeal.
- computation of model – Determinedifferentthing in an image.
- Image identification – Differentiate the obstacles in an image.

At first, the camera caught the image, when the image processing is finished and the output is given to text to speech synthesizer. Then the voice playback output is given to visually impaired peoplevia the headset.

#### IV. RESULTS

The differentsolution of the proposed model are shown below:



**Fig.10. shows the heartbeat rate of the sole.**



## Helping Hand for Un sighted People-Acousticsight



**Fig.11.** The warning notification that has been sent to the user's pre-decided families.

### V. CONCLUSION

In the fast moving world everybody meets their own space of freedom and this is also relevant for the visually disabled people. The need that has been developed between the common person and the unsighted person is remarkable and can be decreased or even get rid of it this need can be satisfied with the help of this tool. So that, our project Acoustic sight will support the visually challenged people to a huge level come up with the need level of space, guiding in navigation, warning the user's families or friends by tracking the location through the app and much more. This will surely meet the basic required of unsighted people. The app growth will be an helping hand for the unsighted people. Therefore, a project will be useful in the health management production modern world everyone needs their own space of

### REFERENCES

1. Alessio Carullo and Marco Parvis (2001) 'An Ultrasonic Sensor for Distance Measurement in Automotive Applications', IEEE Sensor Journal, Vol. 1.
2. K.Gopala Krishnan, C.M.Porkodi, and K.kanimozhi (2013) 'Image Recognition for Visually Impaired people By Sound', International conference on Communication and Signal Processing, Vol. 39, pp. 943-946.
3. Shashank Chaurasis and K.V.N.Kavitha (2014) 'An Electronic Walking Stick for Blinds', International Conference on Information Communication and Embedded Systems(ICICES).
4. Sung Jae Kang, Young Ho, Kim, In Hyuk Moon (2001) 'Development of an Intelligent Guide-stick for the Blind, Seoul of Korea, IEEE International Conference on Robotics & Automation Vol. 4.
5. N.Mahumad, R.K. Saha, R.B. Zafar, M.B.H. Bhuiyan and S.S.Sarwar (2014) 'Vibration and Voice Operated System for Visually Impaired Person', International Conference on Informatics Electronics & Vision (ICIEV) IEEE, pp. 1-5.

### AUTHORS PROFILE



**Dr. V. Kumar Chinnaiyan** M.E., Ph.D. received his M.E. (Power Electronics and Drives) and Ph.D. degrees from PSG College of Technology (PSGCT), Coimbatore. His Ph.D. work is in the area of power quality improvement in multilevel inverters. He was a Best Outgoing Student in his PG programme. He has the industrial experience of around three years as testing and commissioning engineer for LV/HV switch gear and power converters. He is in the teaching profession since 2001. He completed two consultancy project and a sponsored project as Principal Investigator funded by Department of Science and Technology, Government of India, New Delhi, in the domain of Multilevel Inverters and Power Quality Issues. He is an Editorial Board Member and reviewer for many reputed Journal

Publishing houses such as Elsevier Publications, Springer Publications, Taylor & Francis Publications and Medwell publications. He is an active member in IEEE, ISTE and IE(I).



**Abarna M**, pursuing IV year Bachelor degree in Electrical and Electronics Engineering at KPR Institute of Engineering and Technology, Coimbatore, India.



**Jane Lourde Teresha A**, pursuing IV year Bachelor degree in Electrical and Electronics Engineering at KPR Institute of Engineering and Technology, Coimbatore, India.



**Maithreni M**, pursuing IV year Bachelor degree in Electrical and Electronics Engineering at KPR Institute of Engineering and Technology, Coimbatore, India.



**Devisri R**, pursuing IV year Bachelor degree in Electrical and Electronics Engineering at KPR Institute of Engineering and Technology, Coimbatore, India.