

A Surveillance System for Air Pollution Monitoring-Warning

S. Aghalya

Abstract: Air Pollution is growing rapidly and it has become a major concern in every part of the world. It leads to health problems of the entire population. This demands the requirement of Air pollution monitoring system. An IOT based Air pollution monitoring system is developed which monitors air quality and environmental parameters such as Temperature and Humidity over a web server using internet. The concept of IOT helps to access data from any part of the globe. Sensors are used to monitor the harmful gases. The presence of harmful gases above a particular limit can lead to severe health issues and accidents. A threshold is set for pertinent sensors from which we can acknowledge the rise in the gas levels. An email is sent to the respective users when the values exceed the threshold as an alert.

Keywords : Air pollution, IOT sensors, Web server, Internet, humidity and Temperature.

I. INTRODUCTION

Air pollution has become a major concern in every part of the world. A lot of gaseous pollutants is released with the increasing number of vehicles and industries in urban areas. It leads to health problems like lung infection, Heart problems and asthma. The atmosphere is exposed to different types of gas emissions called as primary pollutants. They undergo chemical reaction and form secondary pollutants. In recent times, outdoor air quality has been improved. Every person is exposed to indoor air pollution inside a building. It is due to various factors like poor ventilation, chemicals in cleaning materials, heat and some building materials. This demands the requirement of Indoor Air Quality (IAQ) Monitoring system. Researchers have done the work for monitoring various environmental parameters such as temperature, humidity, carbon monoxide, but only a small attention is given to the measurement of the particular matter. To address this issue, a system consisting of a Microcontroller unit along with the gas sensors and temperature and humidity sensor has been developed in this work.

II. LITERATURE REVIEW

Snehal V, Priya [1] proposed a hierarchy system that includes three levels, device level, connection level and system level. Each level has been designed to do a certain task and the efficacy is certain. These levels are used to provide several services at a real time basis. These layers can communicate with one another wirelessly or through wired means. According to **Krithika R [2]**, the pollution levels of various gases in a particular area are measured by positioning the sensors in that area. The main server is uploaded with these collected pollution levels for further analysis.

Yao-Hua Ho, Hu Cheng Lee, Hsuan-Chon Hu [3] proposed a system to measure temperature, humidity and concentration levels of gases by using sensors. The collected data are uploaded to the information system for further analysis.

Ashfaqur Rahman, Kay Hu [4] proposed a pollution monitoring system in both indoor and outdoor environments to measure gas levels, temperature, humidity and light intensity. They presented a wireless sensor network based system. In this work, a set of sensors is used at each node and it is connected to the central monitoring system.

Gagan Parmar, Sagar [5] developed a prototype model for monitoring the concentration levels of various air pollutant gases using sensors. The data can be collected and sent to Raspberry pi based webserver for display.

Shete, Agrawal S [6] presented the framework to monitor the environment of the city. They used the low cost Raspberry pi system. In this work, they used sensors to measure the parameters such as carbon monoxide, carbon dioxide, temperature and pressure.

Marinov, Marin B [7] proposed a system consisting of a microcontroller unit for monitoring the parameters of the environment with the help of atmospheric sensors and gas sensors. For real time monitoring of the parameters, the sensors are placed in different places. The data is gathered and displayed on the city map.

III. MOTIVATION

We live in a contemporary world where we are surrounded by perilous gas emissions and other factors which adds up to it. Millions of people are being affected by these emissions. Countries like India and China excogitated ideas such as car-pooling and odd-car concept which was a big backfire. Factors such as vehicular emissions, coal mining, carbon consumption led to augmented pollution. Contemplating to all these above factors and to retrospect with the Paris Climate Change summit, there's been few initiatives taken by bourgeois people but there hasn't been any significant advancement or improvement. So, we came up with an idea through which people can acknowledge the pollution levels in an intangible fashion through digital means. This would help people know the amount of damage it inconspicuously inflicts on our environment. The cardinal objective of this work is to excogitate a simple, low-cost and low maintenance air pollution system. Since six billion people have access to their mobile phone and internet, everyone can check for pollution control levels by opening their website or mobile applications.

Revised Manuscript Received on November 01, 2020.

S. Aghalya, Department of Electronics and Communication Engineering,

IV. PROPOSED SYSTEM

Basically, the idea is to place the transmitter which is the Node-MCU concealed in a box like structure on traffic light posts at the main centres of the city. The transmitter can be powered from the electrical connections of the light post or a solar chip can be fitted on the transmitter. These, are really good power sources for the transmitter but if we want something more efficient, reliable and low-cost, we can go for 3V coin cell. They are predominantly used in many IoT and industry 4.0 applications.

The objective of the proposed work is to sense the harmful toxic gases. The proposed system consists of a Node MCU, gas sensors namely: MQ2, MQ7, MQ8, MQ135 and Keyes DHT11 Temperature and Humidity sensor as shown in Figure 4.1. The sensing unit is used to monitor air pollution. The sensors MQ2, MQ7, MQ8 and MQ135 are analog sensors. They are used to measure oxygen, carbon monoxide, hydrogen and carbon dioxide. The DHT11 is the low cost digital temperature and humidity sensor. It produces digital output. The Node MCU includes firmware which runs on the ESP8266 Wi-Fi.

ESP8266 Node MCU consists of a microcontroller unit and a Wi-Fi transceiver. It has 11 General Purpose Input/output (GPIO) pins, voltage regulator, ADC and Micro-USB port. It can be programmed like any other Arduino or other microcontroller. It also has Wi-Fi transceiver on the top. It can be connected to Wi-Fi network, internet, web server, smart phone etc [8].

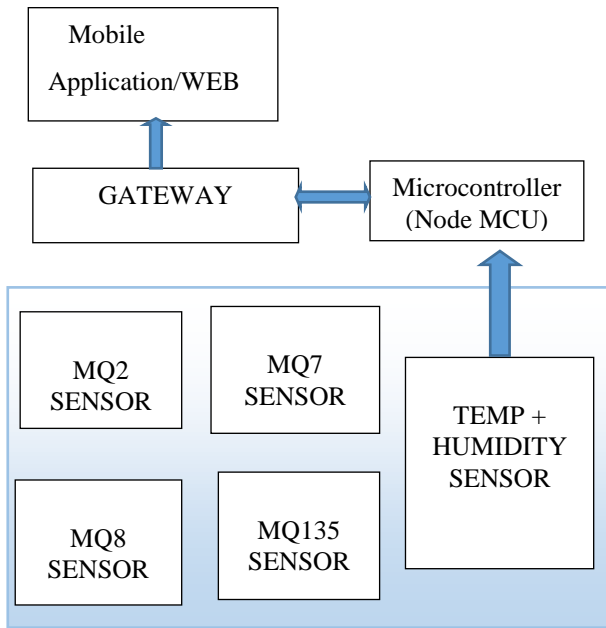

Figure 4.1 Proposed Architecture

The receiving station can be situated somewhere in the centre of the city. The Micro-controller gathers the sensor outputs and sends these data to the computer. Then the data is uploaded to the cloud data set. The cloud consists of a past history of air concentration levels. All the uploaded data are available in the database management system of the centralized warehouse. All collected data is available along with the area code and time stamp, so that it is easy to analyse the pollution levels of different areas. A threshold is set for pertinent sensors from which we can acknowledge the rise in

the gas levels. An email is sent to the respective users when the values exceed the threshold as an alert

V. RESULTS AND DISCUSSION

The perilous gases are sensed and detected on a real time basis. The gases are sensed and accessed through a website which displays the pertinent statistics. The proposed work is used to measure the air quality in different areas. In this work, an experimental setup is developed to measure the gases, temperature and humidity. The data collected from the sensors can be accessed by authorized persons. A threshold is set for pertinent sensors from which we can acknowledge the rise in the gas levels. An email is sent to the respective users when the values exceed the threshold as an alert.

Table 5.1 sensor accuracy

S.no	Sensor accuracy		
	Monitor parameter	Range	Accuracy
1	Oxygen	0-100ppm	±0.2%
2	Carbon Monoxide CO	0-1000 ppm	<5%
3	Carbon di oxide CO2	0-200 ppm	10%
4	Hydrogen H	0-1000 ppm	5%

Table 5.2 Obtained readings:

S.no	parameter	Readings	
		Range	
		Morning	Evening
1	Oxygen	56ppm	47ppm
2	Carbon Monoxide CO	130 ppm	360ppm
3	Carbon di oxide CO2	20 ppm	58ppm
4	Hydrogen H	12 ppm	35ppm

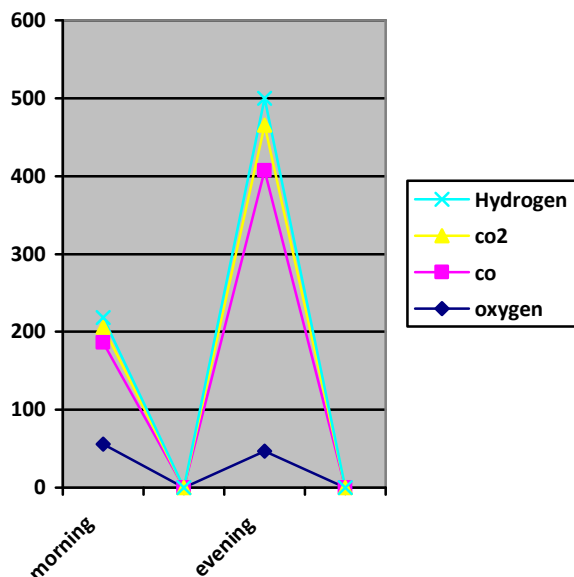

AUTHORS PROFILE



S.Aghalya, works as Professor in the Department of Electronics and Communication Engineering in St Joseph's College of Engineering, Chennai. She got her Ph.D from Anna University, Chennai. Her area of interest includes Mobile Networks, Embedded Systems and Digital Image Processing.

VI. CONCLUSION

An air pollution monitoring system using Raspberry-pi and IOT is developed in this work. It can monitor the levels of pertinent gases and hence can prevent ruinous accidents. Raspberry pi which is known as a single-board computer, controls the entire process. The entire process is connected to internet using Wi-Fi module. The safety of workers in industries can be ensured by using wearable technology. The proposed air monitoring system supports a new technology and it is used to overcome the problems of highly polluted areas. The system also has a feature which enables the people to monitor the pollution level on their mobile phone using the application.

REFERENCES

1. Snehal v, priya "design and implementation of real time geographic pollution monitoring system ", *international conference of computation, power and energy, 2015*
2. krithika.r, a.umamakeswari "cost pollution control and air quality monitoring system using raspberry pi for internet of things", *international conference on energy, communication, data analytics and soft computing (icecds), 2017*
3. ling-juh chen, senior member, ieee, yao-hua ho, hu-cheng lee, hsuan-cho wu, hao-min liu, hsin-hung hsieh, yu-te huang and shih-chun candice lung "an open framework for participatory pm2.5 monitoring in smart cities", *ieee world automation congress, 2012*.
4. ke hu, ashfaque rahman s, hari bhrugubanda and vijay sivaraman "machine learning based metropolitan air pollution estimation from fixed and mobile sensors", *ieee international conference on machine learning and applications, 2018*.
5. Gagan parmar, sagar lakhani "an iot based low cost air monitoring system", *ahilya university, indore, 2017*
6. Shete, rohini, and sushma agrawal. "iot based urban climatemonitoring using raspberry pi", *ieee international conferencein communication and signal processing (iccsp)*, pp. 2008-2012, 2016.
7. Marinov, marin b., ivan topalov, elitsa gieva, and georgi nikolov,"air quality monitoring in urban environments", *39th ieee international spring seminar in electronics technology (isse)*, pp. 443-448, 2016.
8. <https://esp8266-shop.com/product/nodemcu-esp8266-esp-12e/>