

Estimation of Glucose Levels in Blood Sample using A Biosensor

G Manmadha Rao, Gade Chaitanya Prasad, K. Pavani, S Lakshaman Rao, B Prasanna Kumar

Abstract: This paper discusses about estimation of glucose concentration in blood using a Triple pole Complementary split ring resonator (TP-CSRR) antenna. Glucose concentration in blood is the direct indicator of Diabetes disease. The designed microstrip antenna operates in range of 2-5 Ghz and has a resonance frequency of 3.35 Ghz when simulated. When the antenna is excited, blood acts as dielectric load to it. Hence the glucose concentration of blood affects the resonant frequency and amplitude at resonant frequency of the s_{21} parameter of the antenna. Using this information, we can estimate the glucose concentration of blood sample. Debye model was used to model the blood. It is effective in detecting glucose concentration of Type-2 diabetes (70-120 mg/dL). The amplitude sensitivity is 0.58 dB/(mg/ml) and frequency sensitivity is 583 Mhz/(mg/ml).

Keywords: Complementary Split Ring Resonator, Debye Model, Permittivity, Hyperglycemia.

I. INTRODUCTION

Diabetes is a growing disease across the world [2]. With changing lifestyles this disease is spreading its arms into the younger generation too, taking a toll to their happiness. Over 422 million are suffering from diabetes across the world and the rate at which the numbers are rising is baffling. Diabetes is considered as metabolic disorder of hormone insulin production by pancreas gland. This hormone helps cells absorb glucose in blood. So, due to lack of this hormone the glucose level in blood rises making it an apt indicator to test for.

The blood glucose concentration is clinically measured to in mg/dL units i.e., milligrams of glucose in per deciliter of blood sample. In fasting glucose concentration of 100-125 mg/dL is considered normal and more than 126 mg/dL is considered as Hyperglycemia. A concentration less than 100 mg/dL is considered as Hypoglycemia and this too need medical attention.

Manuscript received on May 21, 2021.

Revised Manuscript received on May 27, 2021.

Manuscript published on May 30, 2021.

* Correspondence Author

G Manmadha Rao, Department of Electronics and Communication Engineering, Anil Neerukonda Institute of Technology and Sciences, Vishakapatnam (Andhra Pradesh), India.

Gade Chaitanya Prasad*, Department of Electronics and Communication Engineering, Anil Neerukonda Institute of Technology and Sciences, Vishakapatnam (Andhra Pradesh), India.

K. Pavani, Department of Electronics and Communication Engineering, Anil Neerukonda Institute of Technology and Sciences, Vishakapatnam (Andhra Pradesh), India.

S Lakshaman Rao, Department of Electronics and Communication Engineering, Anil Neerukonda Institute of Technology and Sciences, Vishakapatnam (Andhra Pradesh), India.

B Prasanna Kumar, Department of Electronics and Communication Engineering, Anil Neerukonda Institute of Technology and Sciences, Vishakapatnam (Andhra Pradesh), India.

The current prevalent method of glucose testing involves BGL measurements and can't be used to test the glucose levels in live time. Making Glucose concentration testing easier and chemical free is an hour of need with rising number of patients. The test must be made easier. This paper is one step towards that attempt.

The primary objective of this antenna is to detect blood glucose level around 80-180 mg/dL. The dielectric permittivity of blood changes with varying glucose levels. This blood acts as a dielectric load to the antenna and causes change in amplitude at resonance frequency of s_{21} . The blood container shown in figure is made of Pexaglass material and it along with blood in it acts as dielectric load. The paper organized as follows: Chapter 2 discusses about proposed biosensor and its measurements. Chapter 3 extensively tells how blood was modelled using the Debye model and MATLAB code to find the blood concentrations where we need it. Chapter 4,5,6 discusses about the Performance and sensitivity calculation of the given sensor and we conclude the paper in chapter 7.

II. PROPOSED BIOSENSOR

A. Background

Various sensors have been used in the literature to detect the change in permittivity constant of a material [4]. Patch antennas, Ring antennas, Split ring Resonators were discussed in the literature out of which CSRR was found to be most effective and sensitive. So, we choose to use TP-CSRR in this paper [1].

The design parameters have been optimized for maximum sensitivity of glucose detection.

B. Design

The Triple Pole Complementary Split Ring Resonators (TP - CSRR) were carved on the upper face of FR4 substrate ($\epsilon_r = 4.4$, tangent loss=0.02) and length and breadth is shown in the above table. A glass container is height of height 2.6mm and glass thickness 0.3mm is placed over the TP-CSRR antennas to act as load to the antenna. A blood material is of dielectric permittivity and tangent loss described vividly in next section. It was excited and then s_{11} parameter sweep was used to determine the resonant frequency and amplitude at resonant frequency was used to determine the glucose concentration.



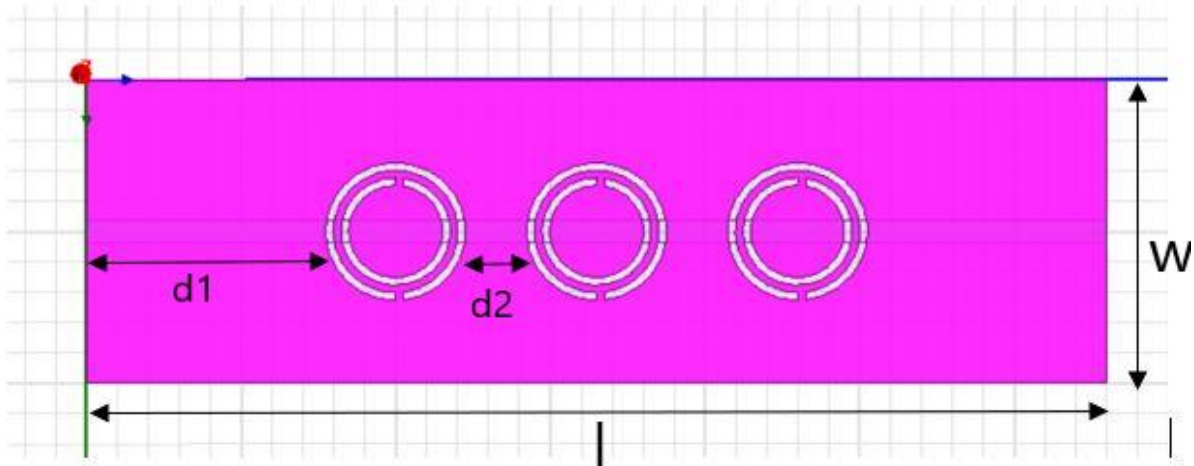

Figure I: CSRR antenna design with labels

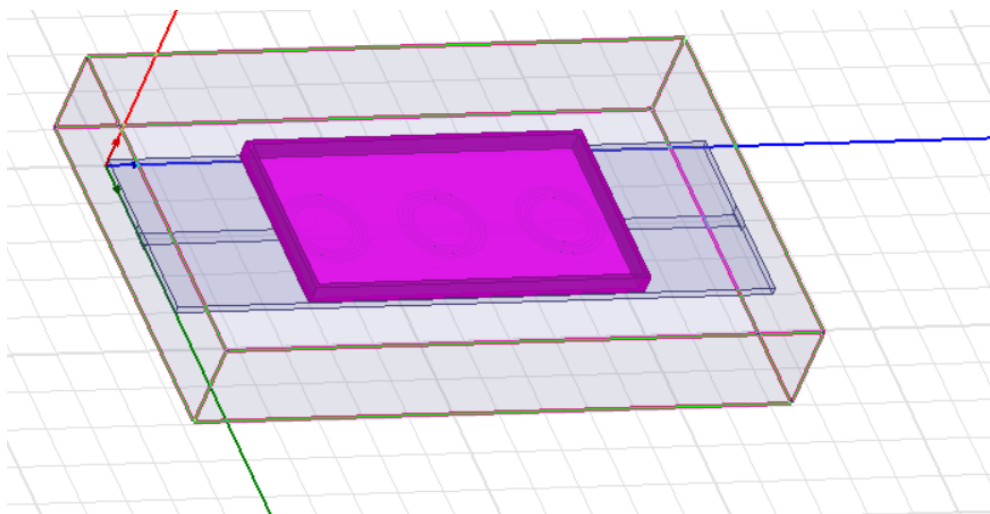

Figure II: Container to accommodate blood sample

C. Design Parameters

Table I: Values of Design parameters

Design parameter	Value (in mm)
Width (w)	20
Length (l)	66
Thickness of substrate(h)	0.8
Slot inner radius (rin)	4.04
Slot outer radius (rout)	4.54
Slot width (s)	0.5
d1	15.46
d2	3.92

III. DEBYE MODEL

Debye model is used to simulate the blood by the following relation [3]. This was published by Peter Debye in the 19th century. According to this model the permittivity of blood is dependent on the frequency(ω). The relative permittivity can be estimated using three parameters which are static permittivity at lower frequencies, the permittivity at higher frequencies and the relaxation time of the medium. For aqueous solution with a solute and solvent this can further be extended using the concentration of the solute(q), which is glucose here.

$$\epsilon_r(\omega, q) = \epsilon_\infty(q) + \frac{\epsilon_{stat}(q) - \epsilon_\infty(q)}{1 + j\omega T(\omega)}$$

Equation I: This equation relates relative permittivity of blood in terms of frequency and glucose concentration

Where each denotes the following,

$$\epsilon_r(q) = 5.38 + 30 \cdot 10^{-3} \cdot q$$

$$\epsilon_{stat}(q) = 80.63 - 0.207 \cdot 10^{-3} \cdot q$$

$$T(q) = 9.68 + 0.23 \cdot 10^{-3} \cdot q \text{ (ps)}$$

IV. SIMULATION PERFORMED

The above-mentioned antenna was designed and blood was defined as a material as described in the Debye model. Then s21 parameter's plot was obtained for various glucose concentrations as shown in Figure 3. To do a comparative study we plotted them in the same graph. The four different plots are corresponding four different concentrations. We can clearly see that the antenna is frequency sensitive as well as amplitude sensitive to the change in glucose concentration.



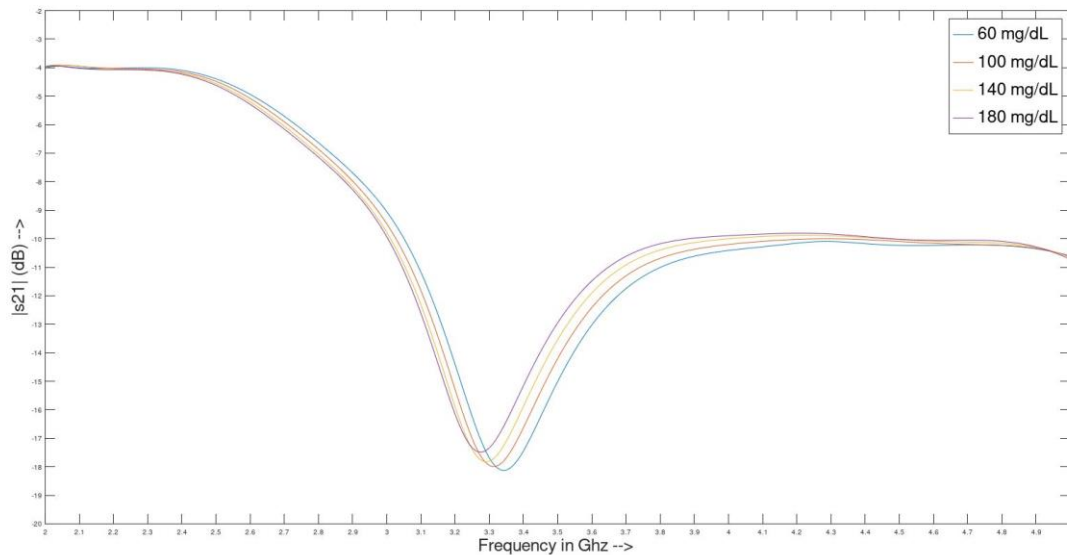

Figure III: s21 parameter plot for four different concentrations

V. OBSERVATIONS

By observing the above, we can note the following values to understand the relation between them.

Table II: Resonant Frequency and their amplitudes at Resonant Frequency Corresponding to concentrations

Concentration (mg/dL)	Resonant Frequency (Ghz)	Amplitude at Resonant Frequency(dB)
60	3.34	-18.1219
100	3.31	-17.9947
140	3.29	-17.8272
180	3.27	-17.4859

VI. RESULTS

When antenna's s21 parameters are obtained with blood with various glucose concentration as load. The above clearly shows us the that the s21 parameter plot varies according to the concentration of the glucose levels in the blood. The Frequency sensitivity of the antenna is 0.0583 Ghz/(mg/ml) and the amplitude sensitivity is 0.53 dB/(mg/ml). So, this difference in s21 parameter can be used to know the glucose concentration in blood.

VII. CONCLUSION

This paper designed and proposed a novel microwave biosensor that is used to measure the glucose concentration in blood in 2-5 Ghz band. A microwave Transmission line was used to excite the TP-CSRrs. This sensor has achieved an Amplitude sensitivity of 0.53 dB/(mg/ml) and frequency sensitivity of 538 Mhz/(mg/ml). To implement a real sensor a micro strip antenna must be printed and it can be analyzed using vector network analyzer (VNA). When an unknown blood sample is loaded onto the glass container its resonant frequency and amplitude at resonant frequency would help us determine the glucose concentration in blood by comparing them with previously obtained data given in Table II.

ACKNOWLEDGMENT

Our sincere Thanks to our department of Electronics and Communications, Anil Neerukonda Institute of Technology and Sciences for giving us a change to pursue this project. Our Heartfelt Thanks to Dr. Manmadha Rao Sir for being our Project Guide. Our Sincere thanks to College management for providing us with this opportunity.

REFERENCES

1. "Non-Invasive Real-Time Monitoring of Glucose Level Using Novel Microwave Biosensor Based on Triple-Pole CSRR". IEEE Transactions on Biomedical Circuits and Systems (Volume: 14, Issue: 6, Dec. 2020).
2. WHO, "WHO World Health Day 2016_WHO calls for global action to halt rise in and improve care for people with diabetes.pdf," World Health Org., Geneva, Switzerland, *Tech. Rep.*, 2016.
3. "Microwave-Based Noninvasive Concentration Measurements for Biomedical Applications". IEEE Transactions on Microwave Theory and Techniques (Volume: 61, Issue: 5, May 2013)
4. "Noninvasive blood glucose measurement using microwave resonators" IEEE trans. Antennas propag., vol. 51, no. 10, pp. 2572–2581, oct. 2003.
5. "Design and analysis of split ring resonator based microstrip patch antenna for x-band applications". ICTACT journal on microelectronics, January 2019, volume: 04.

AUTHORS PROFILE



Dr. G Manmadha Rao, completed Ph.D in RADAR, M.E in Electronic Instrumentation and B.E. degree in Electronics and Communication Engineering from College of Engineering; Andhra University in 2014, 2003 and 1998 respectively. He is in teaching profession for more than 18 years. Presently he is working as Professor in the Department of Electronics and Communication Engineering, Anil Neerukonda Institute of Technology and Sciences, Visakhapatnam, Andhrapradesh, India. He has published 37 research papers in various national and international conferences and Journals. He also published two books; Pulse and Digital Circuits and Pulse and Digital Circuits for JNTUK with Pearson Education in 2010 and 2012 respectively.

Estimation of Glucose Levels in Blood Sample using A Biosensor



Mr. Gade Chaitanya Prasad, is pursuing B.Tech. fourth year in Electronics and Communication Engineering from Anil Neerukonda Institute of Technology and Sciences, Vishakapatnam, Andhra Pradesh..



Ms. K. Pavani, is pursuing B.Tech. fourth year in Electronics and Communication Engineering from Anil Neerukonda Institute of Technology and Sciences, Vishakapatnam, Andhra Pradesh.



Mr. B Prasanna Kumar, is pursuing B.Tech. fourth year in Electronics and Communication Engineering from Anil Neerukonda Institute of Technology and Sciences, Vishakapatnam, Andhra Pradesh.



Mr. S LakshmaRao, is pursuing B.Tech. fourth year in Electronics and Communication Engineering from Anil Neerukonda Institute of Technology and Sciences, Vishakapatnam, Andhra Pradesh.