

Evaluation and Implementation of Different Digital Schemes for FSO Channel

Ritu Namdeo¹, and Dr. Swapnil Nema²

¹Global Nature Care Sangathan's Group of Institutions, Jabalpur, MP, India

²Global Nature Care Sangathan's Group of Institutions, Jabalpur, MP, India

Abstract— Free space optical communication is becoming an increasingly important technology for the wireless market since it introduces a higher data transmission rate and large bandwidth. In this work, we have compared DPSK and OQPSK systems. Several measurements were performed including Bit Error Rate (BER) curves for optimum reception, eye diagram with the variation of input signal and distance of medium for each of the systems. Recent digital fiber optic communication systems address modulation and detection techniques for high spectral efficiency and robustness against transmission impairments. The proposed objective of this project is to design studies and analyze the simulation model of a Digital fiber Communication System using Opti system 7.0. The main objective of this work is to analyze different approaches to mitigate the FSO channel impairments influencing the transmission limitations in Optical Communication. Two modulation formats viz., Differential Phase Shift Keying (DPSK) and Offset Quadrature Phase Shift Keying (OQPSK) have been considered in the present analysis focusing on theoretical considerations, mathematical modelling and computer simulations. The major focus is to analyze, evaluate and characterize different types of optimal encoding schemes to infer the system design parameters in order to achieve an optimum performance.

Keywords— DPSK, OQPSK, RZ, NRZ, BER, FSO, ASE, SMF and DCF.

I. INTRODUCTION

The exponentially increasing demand for the channel capacity in long-haul high-speed transmission systems has pushed the fiber optic communication technology to adopt free space communication system as a viable solution. To maximize the performance of such optical networks, suitable system design strategies to optimize the parameters related to data transmission within the FSO channel characteristics becomes a critical area of research [4]. The phenomenal increase in the ever-growing internet traffic has led to an aggressive demand for higher transmission

bandwidth, and thereby resulting in a dramatic growth of broadband networks. The drive for higher capacity, better flexibility and enhanced functionality has been further expedited due to the emergence of real-time interactive multimedia applications involving enormous data exchange.

The data volume is ever growing and such crucial messages need to be transmitted over global distances in the fraction of a second. This calls for a responsive, secure and bandwidth efficient supporting network to facilitate end-to-end transmission of data/messages of any conceivable size encountered in real-life communication.

Optical communication systems, use light as the carrier of information and optical fiber as the information transmission medium with a capability to transmit high data rates over long distance. However, the main challenge is to increase the bandwidth-distance product of fiber link by researching the mitigation approaches to resolve the intrinsic impairments of fiber channel, i.e., attenuation, dispersion and nonlinearities [1].

II. ADVANCED MODULATION FORMATS

The dramatic development in fiber optic communication is fueled primarily by two reasons: lowering the cost of the transmitted bandwidth and meeting the insatiable demand of increased bandwidth. To cope with the expected bandwidth demand in the near future, new technologies have to be researched, developed and subsequently deployed in long-haul transmission systems. However, as each modulation format exhibits specific features (e.g. Receiver sensitivity, implementation cost/complexity, tolerance to impairments, it becomes a crucial task to characterize an optimal modulation scheme for a particular application. Innumerable factors are to be considered to select an appropriate modulation format, such as-

- Tolerance to interference;

- Improvement attained in bandwidth;
- Ease of implementation.

III. MOTIVATION

One of the important challenges in optical communication systems brought by EDFAs is the expansion of long-haul communication link up to transoceanic distances. However, a new problem results the high optical power levels available from EDFAs makes system performance more vulnerable to various nonlinear effects. In optical communication systems, the input signal to the fiber is usually a composite optical signal modulated with information bit streams. When all the input signal frequencies interact due to fiber nonlinearities, the output bit stream may behave in a complicated way resulting in adverse effects on system performance due to pulse shape and spectrum distortion.

Taznoon Nisar Khajwal published an article in the new year 2020, in which he told many advantages of Free Space Optical Communication. To use all these terms, it would be very beneficial to include various digital formats with FSO. Additionally, there are some weaknesses in conventional optical fiber cables. So, we want to use different digital formats with FSO.

IV. SURVEY

Nobuhiko Kikuchi et al [2], the optical multilevel modulation is one of the attractive candidates to significantly increase the channel bit rate and total capacity of future optical fiber communications. In high-speed optical fiber transmission like 10 Gsymbol/s, the number of signal levels per one symbol is conventionally limited to four (two bits per symbol), for example, as in the differential quaternary phase-shift keying (DQPSK). In order to further increase signal levels, simultaneous modulation of amplitude and phase, that is, amplitude- and phase- shift keying (APSK) is very attractive way to go. One of the issues for the implementation of the multilevel modulation is the bulky transmitter and receivers, which can be significantly improved in future by the development of integrated optical components. As examples of such components, integrated DQPSK modulators based on semiconductor and Lithium Niobate technologies are reported [2].

Gabriel Charlet et al [3], has presented recent progresses observed in the field of modulation formats used for 40 Gb/s optical transmission. As several

applications are targeted, several modulation formats appear as good candidates for industrialization and field deployment. Amplitude, phase and polarization coding are now envisaged in optical transmissions to maximize the system performance. Due to technological constraints, this method has not yet been used 40 Gb/s and the possibility to do it at relatively short term is question- able. Another drawback of the solution is the optical transmission regime where high-accumulated dispersion is encountered. This leads to a large impact of nonlinearities. The single channel impairments can be partially compensated but the WDM impairments seem also severe and cannot be compensated easily [3].

Hanane Alifdal et al [5], has shown that using a technique based on OQPSK modulation can improve system performances. They have tested this technique for different values of the injected power into the optical fiber, and we have compared the results with the conventional system. These results have demonstrated the effectiveness of this method in the way that it can improve the OSNR and BER at the receiver [5]. S.M. Usha et al [6], Low power modulators are most efficient for wire- less communication; the conventional OQPSK modulator consumes more power and area.

V. PROPOSED WORK

Taznoon Nisar Khajwal et al [7], Free space optical communication is one of the best technologies that have number of advantages such as high data rate, rapid ability to increase, free license spectrum and simple deployment. Opti system will allow the design and analysis of these systems become quickly and efficiently.

A. Simulation Set-Up

The PSK Transmitter consists of a PRBS Generator, CW LASERs, Data Modulators, Filters and the Optical Multiplexer. The PRBS generator generates bit sequences at the rate of about 40 Gbps with 27-1 bit. The emission frequencies of CW LASER are equally spaced and are in the range of 193.1 THz. Extinction ratio of MZM is set at 30 dB. The operating wavelengths are as defined by ITU- T standards. The modulated output optical signal is fed into the single mode fiber. The model in Opti System takes into account the unidirectional signal flow. The noise figure of the amplifiers is constant and set to 6 dB. Attenuation of the channel is considered as 0.5 dB.

In the Receiver the signal is detected by PIN detector,

passed through the low pass filter and regenerator. Optical demodulator used low pass filter with filter parameters: 3 dB cut off frequency. The filter parameters have been optimized to give the best result. The optical signal from each port is then passed through PIN photodiode whose reference frequency is 193.1 THz. An electrical low pass Bessel filter follows the PIN photodiode whose cut-off frequency is determined by the modulation used and is optimized at 40 GHz with order 3. Thereafter, 3R regenerator is used to regenerate an electrical signal connected directly to the BER analyzer which is used as a visualizer to generate graphs and results such as eye diagram, BER, Q value, eye opening etc.

Differential Phase Shift Keying (DPSK)

In DPSK, the phase of the modulated signal is shifted relative to the previous signal element for low voltage. If voltage is high then phase is changed. In DPSK the input sequence of binary bits is modified such that the next bit depends on the past bit. In DPSK, the phase of the modulated signal is shifted relative to the previous signal element for low voltage. If voltage is high then phase is changed. In DPSK the input sequence of binary bits is modified such that the next bit depends on the past bit.

Let,

$d(t) = \text{input binary sequence}$

$b(t) = \text{present symbol}$

$b(t-t_b) = \text{past symbol}$

According to definition,

$b(t) = d(t) - b(t-t_b) \dots (1)$

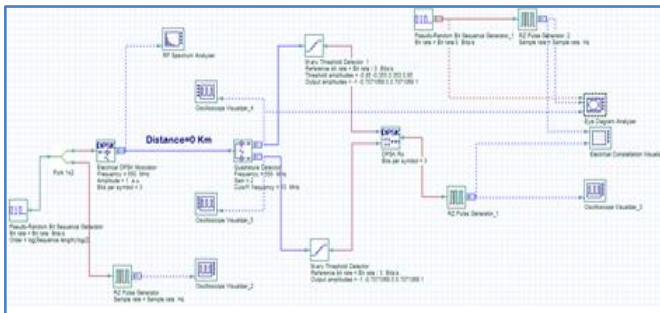

Figure 1: DPSK Electrical Modulation in Opti system 7.0

In the proposed method there may be three methods to modulate the DPSK Signal:

DPSK Electrical. First the DPSK Signal generated electrically and then it is sent via electrical channel. Figure 2

shows the results of BER for 30.375 Mbps as a function of the average received power.

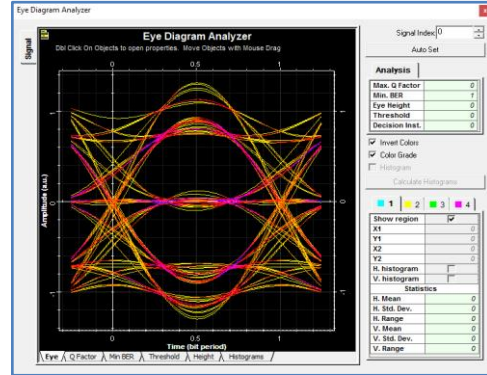

Figure 2: DPSK Electrical Eye diagrams

DPSK Optical. In this method, the signal is optically modulated DPSK format and then transmitted via Optical fiber cable. Figure 3 shows the results of BER for 40 Gbps as a function of the average received power.

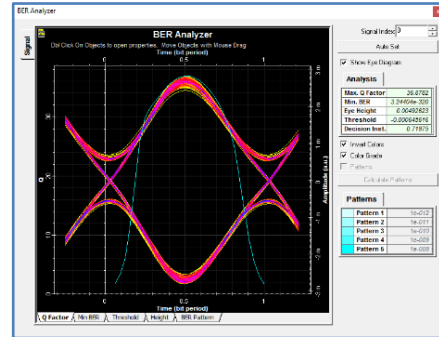

Figure 3: DPSK Optical Eye diagrams

DPSK FSO. In this method, the signal is optically modulated DPSK format and then transmitted via infrared link in free space. Figure 4 shows the results of BER for 40 Gbps as a function of the average received power.

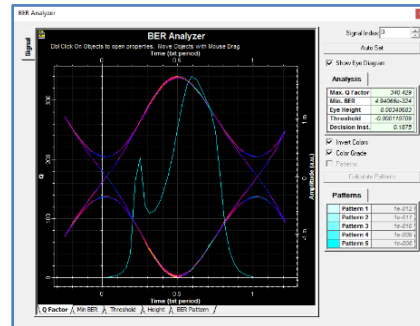

Figure 4: DPSK FSO Eye diagrams

Offset QPSK

If two or more bits are combined in a symbol, then the signal frequency f_b is reduced. This will reduce the transmission bandwidth. In QPSK, two successive bits are combined and make a group. This combination of two bits creates four symbols. When the symbol is changed to next symbol the phase of the carrier is changed by $\pi/2$ Radian or 90° .

Table 1: The Simulated Sensor Host Network

SN	Input successive bits	Symbol	Phase shift in career
1	-1	-1	$5\pi/4$ or -135
2	-1	1	$7\pi/4$ or -45
3	1	-1	$3\pi/4$ or $+135$
4	1	1	$\pi/4$ or $+45$

The OQPSK modulation is a PSK modulation, using two bits per symbol and a delay of one bit in the quadrature signal. Offset Quadrature phase shift referred to as OQPSK. In OQPSK the maximum phase shift is about $\pm 90^\circ$. In this modulator after splitting the bit stream in to odd and even, one-bit stream is made offset by 1-bit period with respect to the other [6].

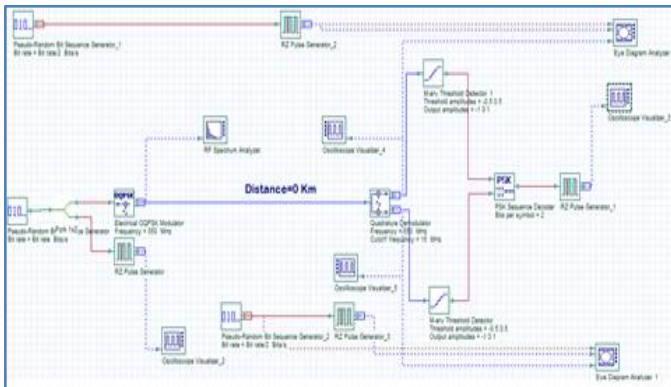

Figure 5: OQPSK Electrical Modulation in Opti system 7.0

In the proposed method there may be three methods to modulate the OQPSK Signal:

OQPSK Electrical. First the OQPSK Signal generated electrically and then it is sent via electrical channel. Figure 6 shows the results of BER for 30.375 Mbps as a function of the average received power.

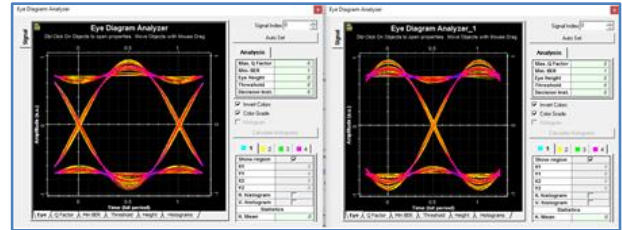

Figure 6: OQPSK Electrical In-phase and quadrature phase Eye diagrams

OQPSK Optical. In this method, the signal is optically modulated OQPSK format and then transmitted via Optical fiber cable. Figure 7 shows the results of BER for 40 Gbps as a function of the average received power.

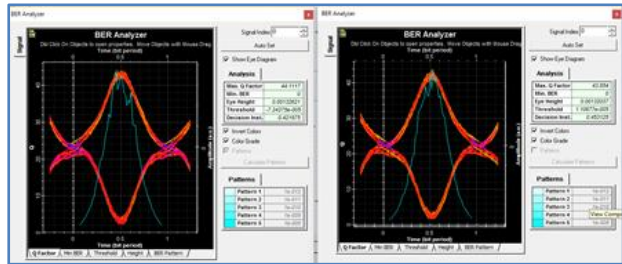

Figure 7: OQPSK Optical In-phase and quadrature phase Eye diagrams

OQPSK FSO. In this method, the signal is optically modulated OQPSK format and then transmitted via infrared link in free space. Figure 8 shows the results of BER for 40 Gbps as a function of the average received power.

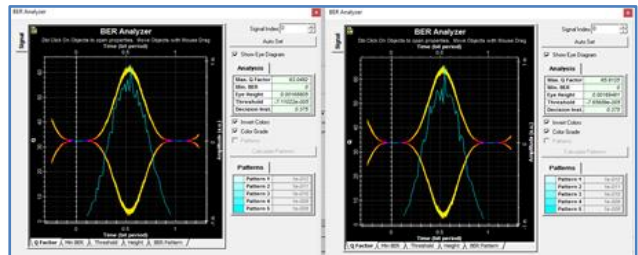

Figure 8: OQPSK FSO In-phase and quadrature phase Eye diagrams

VI. RESULT AND COMPARISONS

Now, we will make a detailed comparison between DPSK and an OQPSK. Table 2 displays the measured parameters for both DPSK modulation and OQPSK modulation techniques. In general; a minimum acceptable

BER rate is about 10^{-9} [8].

Table 2: Parameters of different Digital Formats

Modulation Format	DPSK			OQPSK					
	Electrical	Optical	FSO	Electrical		Optical		FSO	
				I	Q	I	Q	I	Q
Bit rate (bps)	30.375 Mbps	40 Gbps	40 Gbps	30.375 Mbps		40 Gbps		40 Gbps	
Sample Rate (Hz)	19.44 GHz	1280 GHz	1280 GHz	19.44 GHz		1280 GHz		1280 GHz	
Sequence length (bits)	256 bits	128 bits	128 bits	256 bits		256 bits		256 bits	
Samples/bit	64	32	32	64		32		32	
Number of samples	16384	4096	4096	16384		8192		8192	
frequency (Hz)	550 MHz	193 THz	193 THz	550 MHz		193 THz		193 THz	
Gain (dB)	2 dB	5 dB	2 dB		5 dB		
Bits per symbol	32	32	32	32		32		32	
Cutoff Frequency (Hz)	10 MHz	10 MHz	10 MHz	10 MHz		10 MHz		10 MHz	
Input power (W)	4mW	4mW	4mW			4mW		4mW	
wavelength (nm)	1550 nm	1550 nm		1550 nm		1550 nm	
distance (KM)	0 km	60 km	60 km	0 km		12 km		60 km	
Attenuation (dB/Km)	0	0.2	0.2	0		0.2		0.2	
Q- Factor	0	36.0093	88.689	0	0	33.966	36.1928	15.7604	16.5866
Eye Height (a.u.)	0	0.0049397	0.000210345	0	0	0.0010685	0.0010681	9.0292e-005	9.1999e-005
Bit Error Rate	1	4.94066e-324	4.94066e-324	1	1	3.5219e-253	3.9359e-287	2.91076e-56	4.34697e-62

VII. CONCLUSIONS

Low power modulators are most efficient for wireless communication; the conventional OQPSK modulator consumes more power and area [6]. If the power factor is more important, then we will give priority to DPSK because OQPSK is more power consumer. We had assumed about 0 distance in DPSK Electrical modulation, so BER=1 was getting. There is an ideal condition which is practically difficult to meet. In DPSK Optical modulation, we have used two types of optical cables - Single Mode Fiber and Double Mode Fiber. Distance of Single Mode Fiber is 10 km and distance of two Double Mode Fibers is 25-25 km separately. The total distance is 60 km. This is an optimum value. By increasing the distance beyond this, BER starts to

disturb. This means that no more distance can be taken after this. Therefore, it is mandatory to install the Regenerators.

For ideal condition, 0 km distance has been taken in DPSK electrical format. A distance of 60 km was then taken in single-mode and dual-mode fibers with an Attenuation value of 0.2 dB/km, which is also the default value. When free space communication is used the Quality Factor for the same bit error rate increased from 36.0093 to 88.689. Subsequently, when used OQPSK, the distance achieved is only 12 kilometers. If taking more distance, the quality factor will be reduced to 0. Hence, 12 kilometers is the optimal distance. When free space communication is used to transmit OQPSK, it increased the distance to 60 kilometers. On doing this, the Quality Factor did not 0, but it is

definitely reduced. This means that, OQPSK received much less Quality Factor compared to the DPSK, when making distance in free space communication. From the table above it is clear, that free space communication is a better option than optical fiber to take advantage of OQPSK.

References

- [1] A. R. Chraplyvy and R.W Tkach, What is the Actual Capacity of Single-Mode Fibers in Amplified Lightwave Systems, IEEE Photonics Technology Letters, Volume 5 (1993), 666-668.
- [2] N. Kikuchi, Amplitude and Phase Modulated 8-ary and 16-ary Multilevel Signaling Technologies for High-Speed Optical Fiber Communication, SPIE Proceedings, Volume 6021 (2005), 17-18.
- [3] Gabriel Charlet, Progress in Optical Modulation Formats for High-Bit Rate WDM Transmissions, IEEE Journal of Selected Topics in Quantum Electronics, Volume 12 (2006), 469-483.
- [4] Abu Bakar Mohammad, Optimization of FSO System in Tropical Weather using Multiple Beams, Proc. of 2014 IEEE 5th International Conference on Photonics (ICP), Volume 5 (2014), 109-112.
- [5] Hanane Alifdal, Farid Abdi and Fouad Mohammed Abbou, Performance Analysis of an 80Gb/s WDM System using OQPSK Modulation under FWM Effect and Chromatic Dispersion, IEEE Transaction, (2017).
- [6] S. M. Usha and H. B. Mahesh, Low Power and Area Optimized Architecture for OQPSK Modulator, IEEE Transaction, (2019), 123-126.
- [7] Taznoon Nisar Khajwal, Performance Analysis of FSO-SISO and FSOWDM Systems under Different Atmospheric Conditions, 7th International Conference on Signal Processing and Integrated Networks (SPIN), (2020), 312-316.
- [8] Shaina, and Amit Gupta, Comparative Analysis of Free Space Optical Communication System for Various Optical Transmission Windows under Adverse Weather Conditions, Twelfth International Multi-Conference on Information Processing, (2016), 99-106.