

**IEEE**  
**COMCAS2021**



INTERNATIONAL CONFERENCE ON MICROWAVES, COMMUNICATIONS,  
ANTENNAS, BIOMEDICAL ENGINEERING & ELECTRONIC SYSTEMS

**1-3 November 2021**

David Intercontinental Hotel  
Tel Aviv, Israel

# The Filtered Gaussian Primitive Diamond Channel

ASIF KATZ



# The Filtered Gaussian Primitive Diamond Channel

ASIF KATZ<sup>(1)</sup>, MICHAEL PELEG<sup>(1),(2)</sup> AND SHLOMO SHAMAI<sup>(1)</sup>

TECHNION-ISRAEL INSTITUTE OF TECHNOLOGY<sup>(1)</sup>, RAFAEL LTD<sup>(2)</sup>

IEEE COMCAS, 1-3 NOVEMBER 2021, TEL AVIV, ISRAEL



# Outline

---

- Introduction
- Relaying
- Diamond primitive relay channel
- The information bottleneck problem
- Relaying over frequency dependent channels - Extending the water pouring approach
- Oblivious diamond relay channel
- Non-oblivious diamond relay channel
- Time-sharing and superposition approaches
- Optimal solution properties and rate comparison
- Conclusions and outlook

# Introduction

Communication systems requirements:

- Higher communication capacity
- Higher spectral efficiency
- Lower power consumption
- Resource pooling
- Scalability

Modern and future communication system infrastructure:

- Central unit (CU)** - performing signal processing and control
- Remote radio heads (RRH)** - performing the radio frequency (RF) functions of amplification, reception and basic signal processing, denoted in our work as “Relays”.

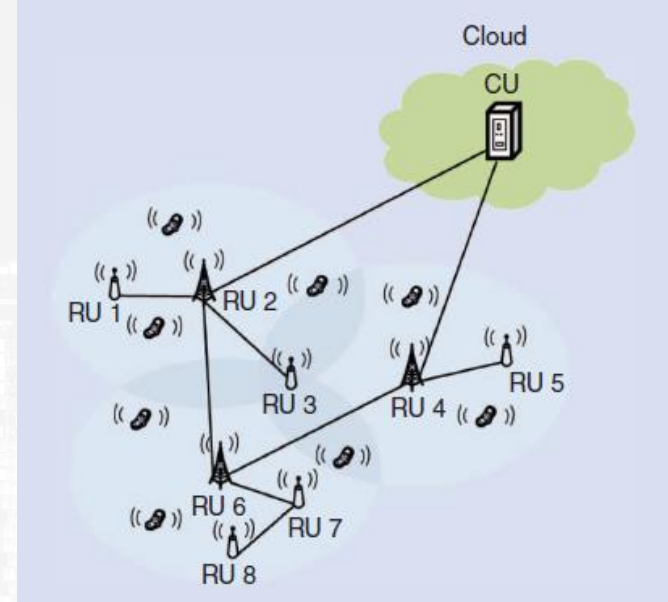

# Relaying

The Relays and the CU are connected by digital links which may be optical fiber links, digital RF links (for example: Common Public Radio Interface (CPRI)) or internet-based systems.

We distinguish between two relay cases:

**Oblivious relay** - there is no a priori knowledge of the modulation or the coding at the relay, thus the relaying system is universal and can serve many diverse users and operators.

**Non-oblivious relay** - there is a priori knowledge at the relay, thus the relay can decode the message.

# Diamond primitive relay channel

- We investigate the **uplink** using the case of **Gaussian channel** with identical frequency response of the channels from X to Y.
- Y is encoded to Z at the relay, which is then sent to the destination with a rate limited ideal fronthaul link.
- **Oblivious relay** - compress and forward (CF) method is used, using **joint decompression/decoding** (equivalent to optimized **Wyner-Ziv** compression). We use Gaussian-distributed transmission symbols which are optimal at high fronthaul bitrates.
- **Non-oblivious relay** - we use the decode and forward (DF) method.

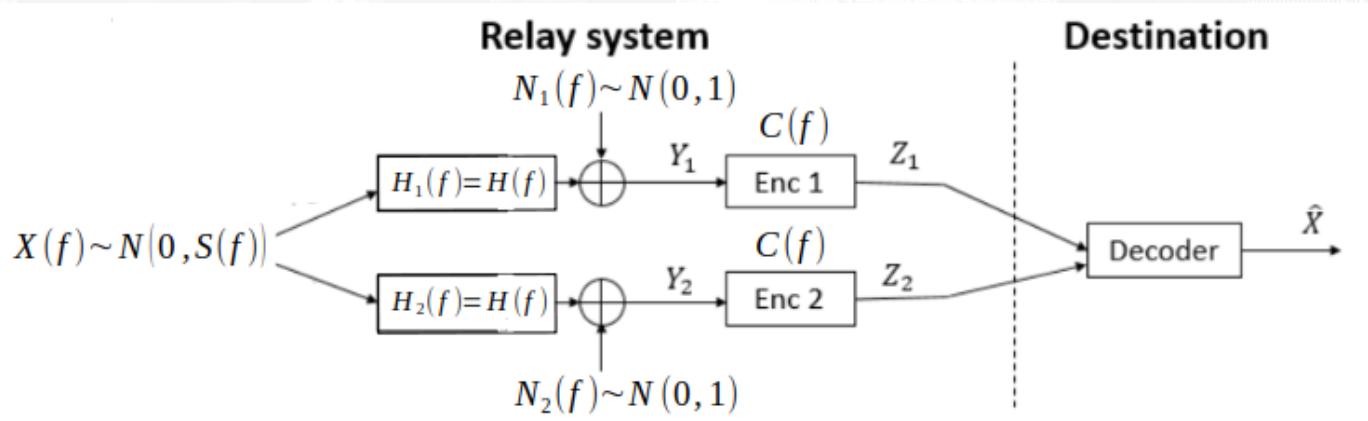



# The information bottleneck problem

The information bottleneck [Tishby-Pereira-Bialek, 1999] adds a rate constraint to the known AWGN channel model, which is necessary in order to evaluate CRAN performance with rate constrained fronthaul digital links.

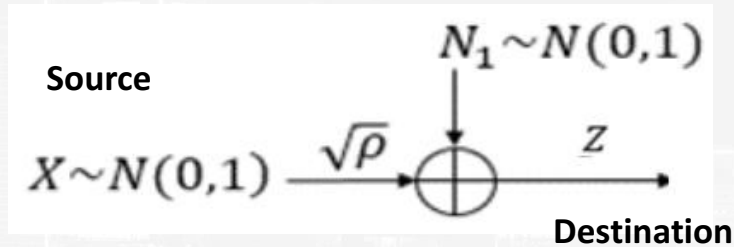

$$I(X; Z) = \frac{1}{2} \log_2(1 + \rho)$$

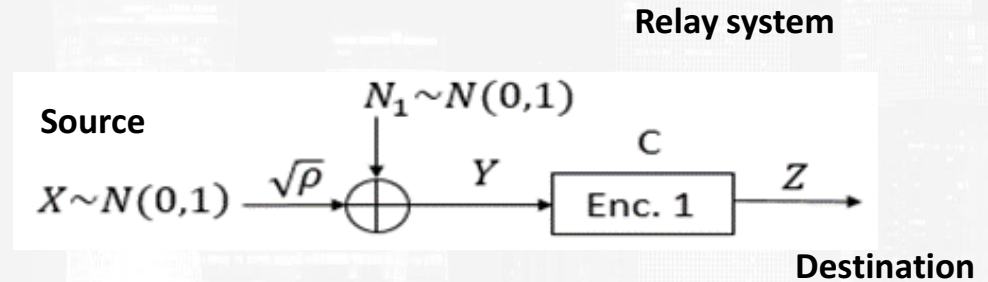

=

≤

# Water pouring

Water pouring is a known result of frequency-dependent rate optimization under power constraint. This result was shown in [Shannon, 1949].

However, in the bottleneck problem a rate constraint is also needed.

This requires a more general water pouring approach.

$$\begin{aligned} & \max_{S(f), C(f)} \int_0^W I(f, S(f), C(f)) df \\ & \text{s.t. } \int_0^W S(f) df \leq P, \int_0^W C(f) df \leq C \end{aligned}$$

$$\begin{aligned} & \max_{S(f)} \int_0^W I(f, S(f)) df \\ & \text{s.t. } \int_0^W S(f) df \leq P \end{aligned}$$

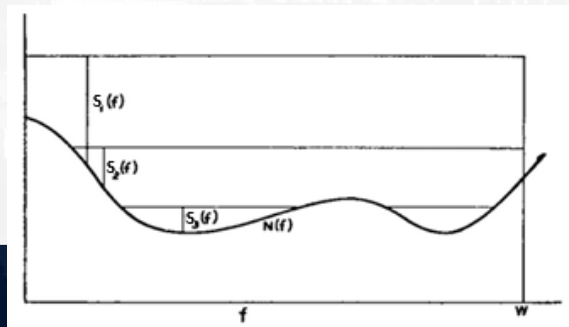



# Relaying over frequency selective channels - Generalized water pouring approach

$\frac{1}{2}C(f)$  – rate allocation

$S(f)$  – power allocation

$H(f)$  – channel response (flat for each  $df$ )

$$\text{SNR}(f) = S(f) |H(f)|^2$$

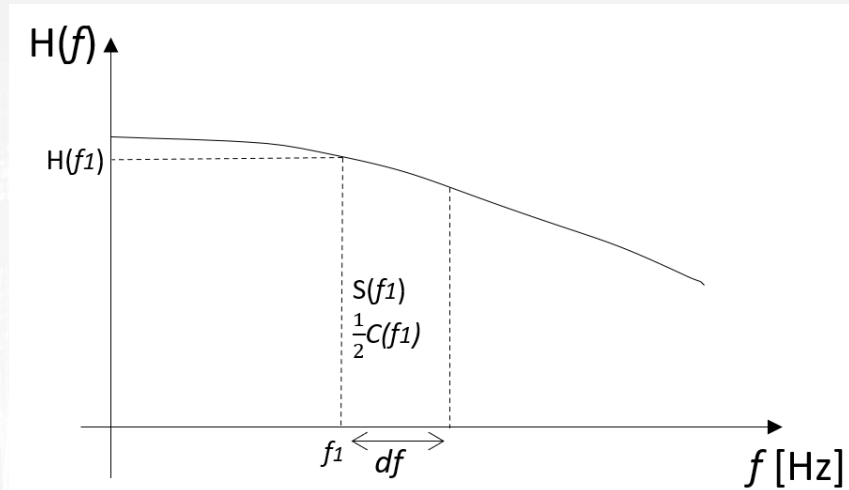

- By **Nyquist**, for a channel with bandwidth  $df$  and **no interference**, the maximal symbol rate equals  $2df$ .
- We assign a rate of  $0.5C(f)$  bits per channel use so the total rate in each band equals  $C(f)$ .
- In the Gaussian model the different bands are independent.

# Oblivious relay - information bottleneck for the diamond relay communication channel

For the **discrete-time real gaussian signal** over oblivious diamond relay gaussian channel, optimal solution was shown in [Sanderovich-Shamai-Steinberg-Kramer, 2008].

$$\text{SNR} = P_{CF}$$

$$\text{Fronthaul rate} = C_{CF} \text{ [bits/channel use]}$$

$$R_{CF} = \frac{1}{2} \log_2 \left[ 1 + 2P_{CF} \cdot 2^{-4C_{CF}} \cdot \left( 2^{4C_{CF}} + P_{CF} - \sqrt{P_{CF}^2 + (1 + 2P_{CF}) \cdot 2^{4C_{CF}}} \right) \right]$$

# Oblivious diamond relay communication channel

**Optimal solution** was derived in [Katz-Peleg-Shamai, COMCAS 2019] by choosing the solution where the function is in a concave region and using grid search method.

The optimal solution allocates zero power and rate for certain frequencies, so it **concentrates power and rate** allocation in the best frequencies. This was also shown for the single relay channel in [Homri-Peleg-Shamai, 2018].

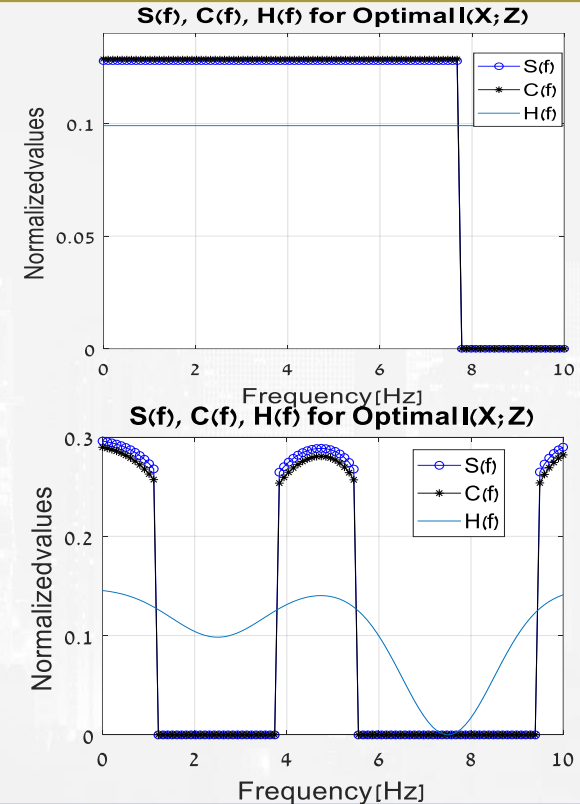

## Non-oblivious diamond relay communication channel

Non-oblivious diamond relay Gaussian channel optimal solution is the known broadcast channel capacity with  $\text{SNR}_1 = \text{SNR}_2 = P_{DF}$  :

$$R_{DF} = \frac{1}{2} \log_2(1 + P_{DF}) [\text{bits/channel use}]$$

Each relay transmits half of the message, therefore the required fronthaul rate is:

$$C_{DF} \geq \frac{R_{DF}}{2} = \frac{1}{4} \log_2(1 + P_{DF}) [\text{bits/channel use}]$$

# First approach - Time-sharing

We want to use time sharing with both CF and DF.

In the first phase, both relays use DF over time  $T_{DF}$  with power  $P_{DF}$  and fronthaul rate  $C_{DF}$ .

In the second phase both relays use CF over time  $T_{CF}$  with power  $P_{CF}$  and fronthaul rate  $C_{CF}$ .

The time allocation is done according to the total average power and rate constraints.

$$R_{TS} = T_{DF} \cdot R_{DF}(P_{DF}) + T_{CF} \cdot R_{CF}(P_{CF}, C_{CF})$$

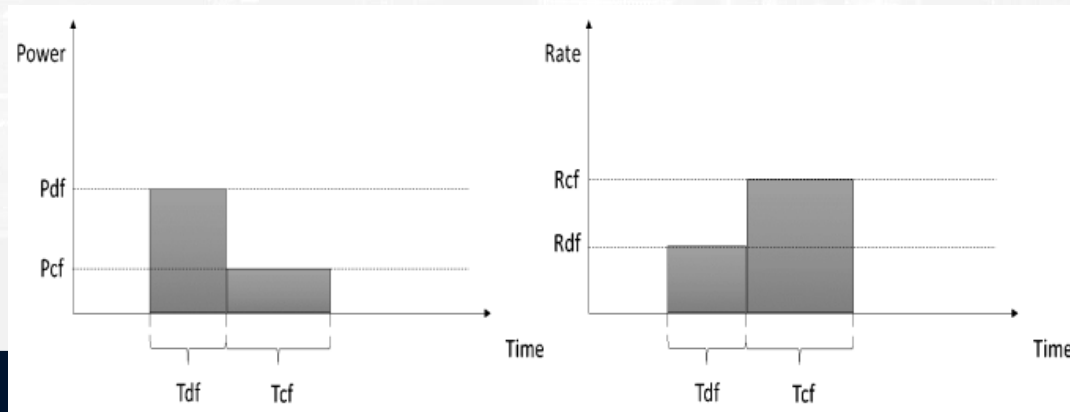

## Second approach - Superposition coding

Transmit DF symbol along with CF letter.

$$Y_i = X_{DF} + X_{CF} + N_i$$

DF symbol will be decoded at the relay and then transmitted to the destination.

It will then be subtracted from the relay input, so the remaining CF symbol with the channel noise will next be transmitted to the destination.

CF symbol will be decoded from the information received from both relays.

In this scheme CF operation will remain the same.

DF operation is affected from the CF symbol which acts as an additional noise to the relay decoder.

$$R_{SPC} = R_{DF} \left( \frac{P_{DF}}{1 + P_{CF}} \right) + R_{CF}(P_{CF}, C_{CF})$$



# Optimality of time-sharing over superposition coding

- For our system, we proved that the superposition coding optimal solution is:  $\max\{R_{DF}, R_{CF}\}$
- Time-sharing has equal or better performance than CF only and DF only.
- Time-sharing has equal or better performance than superposition coding, so it is superior in our case.
- Therefore, we use time-sharing approach with our calculation.

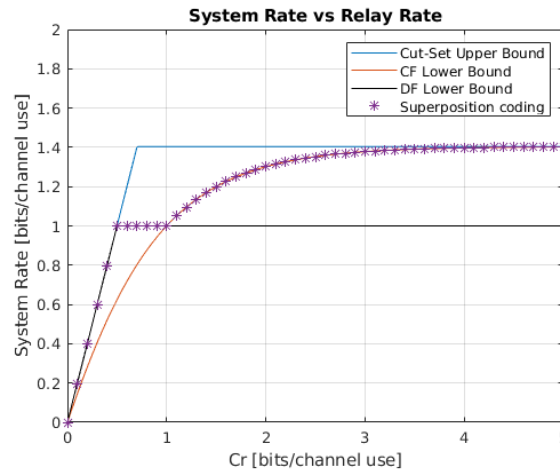

# Time-sharing system performance for flat frequency channel response

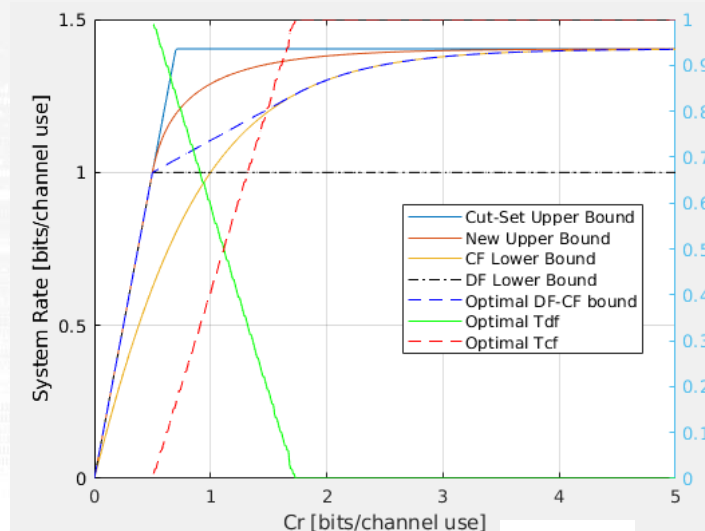
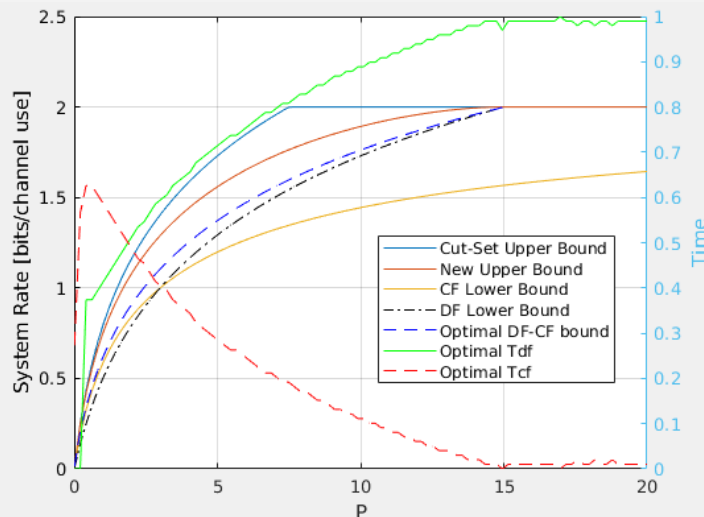

Low SNR – CF is preferred.  
As the SNR increases, DF is added in order to increase the system rate

Low relay rate – DF is preferred.  
As the relay rate increases, CF is added in order to increase the system rate

# Time-sharing system performance for frequency selective channel response

We found the optimal frequency dependent allocation of powers and relay bitrates. The domain is divided into 3 regions:

- The first region with low filter values has no allocation
- Second region has only DF allocation
- Third region has only CF allocation

Between the regions there are points of time sharing, either partly DF or time sharing between CF and DF.

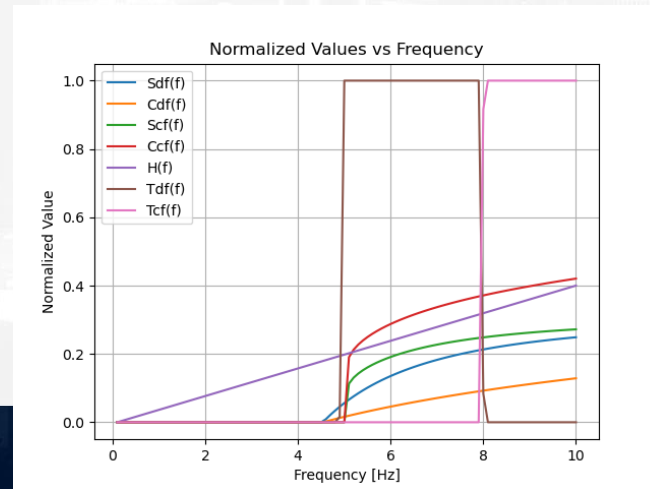
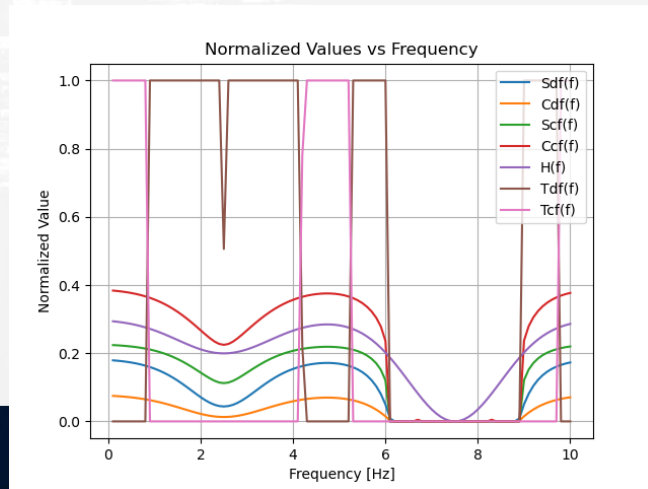

# Optimal solution properties

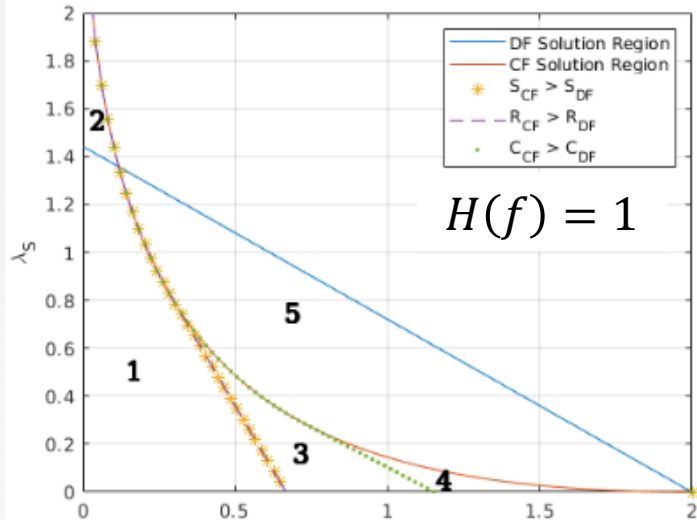

- 1) The region where both CF and DF are allocated and CF has higher power, channel rate and relay rate.
- 2) In this region only CF can be allocated,
- 3) Here CF has higher relay rate.
- 4) DF has higher power, channel rate and relay rate.

5) Only DF is allocated.

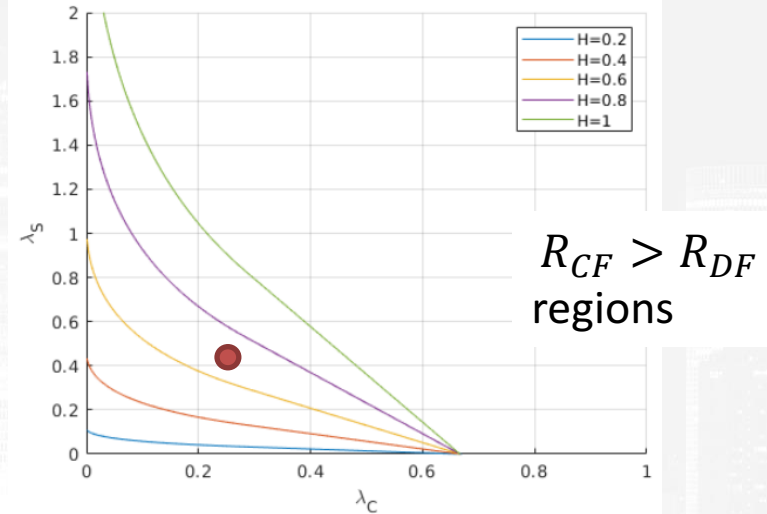

The optimal  $(\lambda_C, \lambda_S)$  defines a filter value  $H(f) = H_{TH}$  such that:

$H(f) > H_{TH}$  - CF is allocated

$H(f) < H_{TH}$  - DF is allocated

# System rate comparison

The system rate results in [bits/sec] for  $P=100$ [W] and  $C=9$ [bits/sec] are summarized in the following table:

Case	Oblivious Independently encoding	Oblivious CF	Oblivious Collaborative encoding	DF and CF time-sharing	Oblivious CF $C=\infty$
Frequency flat filter	13	15.3	16.4		43.9
Frequency dependent filter	6.5	6.9	8.1	7.5	10.4

# Conclusions and outlook

---

We extended known optimized relaying results over frequency flat channels to **frequency-selective** channels.

We studied the combination of CF and DF by superposition in the same time and frequency resource as the classical scheme used for broadcast channels and proved that this approach yield no improvement over time-sharing.  
Therefore, time-sharing is the **superior** approach in our case.

We found the optimal DF-CF time-sharing frequency dependent allocation of powers and relay bit rates. We investigated this solution properties and compared its performance to the oblivious processing.

For future work we suggest to examine whether binning can improve the achievable rates, which is an open problem also in the discrete time primitive diamond channel.



**Thank you!**

# References

- S.H. Park, O. Simeone, O. Sahin, and S. Shamai, "Fronthaul compression for cloud radio access networks: Signal processing advances inspired by network information theory," *IEEE Signal Processing Magazine*, vol. 31, no. 6, pp. 69–79, November 2014.
- D. Camps-Mur et al., "5G-XHaul: A Novel Wireless-Optical SDN Transport Network to Support Joint 5G Backhaul and Fronthaul Services," in *IEEE Communications Magazine*, vol. 57, no. 7, pp. 99-105, July 2019.
- N. Tishby, F. C. Pereira, and W. Bialek, "The information bottleneck method", in Proc. 37th Annual Allerton Conf. on Comm., Control, and Computing, , pp. 368-377, 1999.
- I. E. Aguerri, A. Zaidi, G. Caire, and S. S. Shitz, "On the capacity of cloud radio access networks with oblivious relaying," *IEEE Transactions on Information Theory*, vol. 65, no. 7, pp. 4575-4596, 2019.
- A. Winkelbauer and G. Matz, "Rate-information-optimal Gaussian channel output compression," 2014 48th Annual Conference on Information Sciences and Systems (CISS), 2014, pp. 1-5.
- C. E. Shannon, "Communication in the Presence of Noise," in Proceedings of the IRE, vol. 37, no. 1, pp. 10-21, Jan. 1949.
- A. Homri, M. Peleg and S. Shamai (Shitz), "Oblivious Fronthaul-Constrained Relay for a Gaussian Channel", *IEEE Trans. on Communications*, vol. 66, no. 11, November 2018, pp. 5112-5123.
- A. Sanderovich, S. Shamai (Shitz), Y. Steinberg and G. Kramer, "Communication via decentralized processing", *IEEE Trans. Information Theory*, vol. 54, no. 7, pp. 3008-3023, July 2008.
- A. Katz, M. Peleg and S. Shamai (Shitz), "Gaussian Diamond Primitive Relay with Oblivious Processing," 2019 IEEE International Conference on Microwaves, Antennas, Communications and Electronic Systems (COMCAS).
- A. Katz, M. Peleg and S. Shamai (Shitz), "The Filtered Gaussian Primitive Diamond Channel", arXiv:2101.09564 (2021).