

# Failure Prediction of Wind Turbine using Neural Network and Operation Signal



Dong Hwa Kim, Young Sung Kim

**Abstract-** This paper deals with a novel prediction method for wind turbine by using neural network and operating data. As wind turbine transfer wind energy to electrical power energy, its structure has rotation part that capture wind energy, mechanical part, and electrical part that convert from mechanical rotation to electrical energy. Its working environmental situation is so bad like high mountain, sand desert, and offshore to capture good wind situation. Therefore, its control and monitoring should have high reliability for long terms during operation because its maintenance and repairing is very difficult and economically high cost. As wind turbine system is composed of three parts, there are many components that should be monitored to failure. This paper suggests neural network and operation data-based prediction method that can predict components' failure through data comparison and neural network's training function with easy expression of 'Yes' or 'No' for operator.

**Keyword:** Wind turbine, Monitoring, Neural network, Prediction

## I. INTRODUCTION

Currently, many policies, scientists, and engineers have been interesting in research motivation wind of turbine because of energy issues and environmental problems [1, 2].

Wind turbine system have large rotors and energy converter that run under wind condition (direction and speed) and weather environments (weather, dust, cold and hot, storm, land and offshore, and etc.). So, its control and monitoring technology has been required reliability for maintenance free and lower cost operation. Traditionally, monitoring system for many components including sensor signal failure has been using sensor-based mechanical system. However, it is limited in overall system's fault tolerance monitoring because wind turbine system has many components in nacelle including turbine and tower, and sensors. Additionally, almost cases, WTEP (Wind Turbine Electric Power system) are located in mountain and offshore to receive strong wind energy. Therefore, it makes difficult maintenance and operation. That is, wind turbine monitoring and controller design systems should be reliable for long term during operation [1-6].

Because WTEP is composed of many components such as mechanical part, electric components, sensor, and converters, its dynamic system has strong multivariable and highly nonlinear behavior. However, it is required strong safety and reliability for running over a wide range from bottom to up. Herein, we need to introduce advanced control and monitoring to achieve efficiency and low cost for operation [9].

For highly reliability and maintenance free, prediction method is needed but it is difficult only using the traditional method. Therefore, recently, AI based advanced prediction methods such as machine learning (or deep learning), AI based optimization algorithms (neural network, fuzzy, bacterial foraging, particle swarm optimization, and etc.) have been attention [5, 22, 25, 29].

Monitoring method of wind turbine can be approached by using only signal situation but it is available by using control method. So, we had better understand control system of wind turbine.

This paper provides fault tolerance prediction method by neural network and operation data of control system. This paper has two steps: First step is data (signal point) selection for the input of neural network; Second step is the design of neural network structure. The neural network of this paper compares operation data (signal) of control system used as one of many inputs to others used as reference input (estimation value). The resultant value produces 'Yes' or 'No' signal to announce for operator's failure easy understanding. It means that this paper's idea is unique.

## II. LITERATURE REVIEW OF WIND TURBINEMONITORING

Ref. [6] provides model for specified control. This paper's key is to offer high-reliability solution for control in simulator.

Ayse et al [7] suggests sensor-based validation and fault detection of wind turbine. Temperature sensor for the SCADA is used for monitoring system.

Ref. [8] offers the modelling aspects for power system operators. This paper also mentions model structure for the stability of wind turbine.

This paper [9] shows fault tolerant tracking using robust estimation and compensating to sensor and actuator simultaneously.

Francesco et al [10] studies to the wind turbine generator fault diagnosis method through SCADA system for the healthy condition of wind turbine of Italy.

This paper [11] studies the thermal behavior condition of gear of wind turbine.

Manuscript received on November 16, 2021.

Revised Manuscript received on November 29, 2021.

Manuscript published on November 30, 2021.

\* Correspondence Author

**Dr. Dong Hwa Kim\***, Researcher, Seoultech NDT Research Center, Seoul National University of Science & Technology, South Korea. E-mail: koreahuca@gmail.com

**Young Sung Kim**, Seoultech NDT Research Center, Seoul National University of Science & Technology, South Korea. E-mail: youngsk@seoultech.ac.kr.

©The Authors. Published by Blue Eyes Intelligence Engineering and Sciences Publication (BEIESP). This is an open access article under the CC BY-NC-ND license (<http://creativecommons.org/licenses/by-nc-nd/4.0/>)

## Failure Prediction of Wind Turbine using Neural Network and Operation Signal

For that, this paper uses a detailed information of wind turbine gear box and the temperature data of SCADA for fault condition detection.

Ref. [12] presents condition monitoring method using SCADA. This paper uses 5MW wind turbine model for study.

Kevin et al [13] shows identifying method automatically for fault using SCADA. However, it is not research for monitoring system.

This paper [14] deals with predictive maintenance method to improve wind turbine reliability using SCADA.

Wenxian Yang et al [15] research the quantitative assessment of the health condition of a turbine under varying operational conditions. They conduct both laboratory and site verification tests.

This paper [16] deals with deep learning-based faults about component under operation condition using SCADA.

Vasishtha et al [17] provides noise signal condition by AE when wind turbine operations. This paper uses between 20Hz and 10KHz as signal.

This paper [18] focuses on AE based-monitoring under different wind turbine condition. For this, this paper uses k-means clustering algorithm for data getting.

This paper [19] presents review of many research papers. It deals with AE, AI including. This paper is review paper. So, there is no research material.

This paper [20] suggests remote monitoring method based on AE as well as development of software for automated statistical processing of AE data.

Ref. [21] illustrates monitoring system of wind turbine using wavelet method.

Ref. [22] provides an overview of the predictive maintenance frameworks.

This paper [23] deals with the failure prediction of wind turbine system using SCADA. This paper suggests forecasting method of temperature condition of wind turbine gear box.

This paper [24] illustrates bearing fault diagnostics method using deep learning. First, this paper reviews briefly the conventional machine learning for bearing fault applications. And then, this paper reviews various deep learning theories for bearing fault diagnostics.

Ref. [25] offers simulation process for wind turbine noise using ANFIS under Matlab/Simulink.

This paper [26] introduces only power prediction method by neural network. However, it is not including component failure.

### III. DYNAMIC MODEL OF WIND TURBINE SYSTEM FOR COMPONENT IDENTIFICATION

#### A. The Behavior of the Wind Turbine System

##### Betz's law for Wind Turbine and Wind Energy

This paper uses Betz model approach for input of the wind turbine model to describe prediction system.

The wind turbine is a driving system that conversion the kinetic energy of wind into mechanical energy as shown in Figure 1.

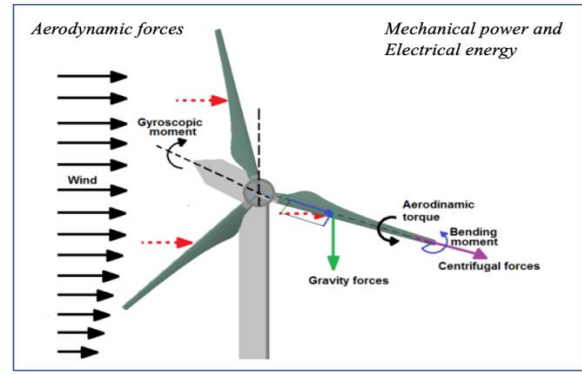

Figure. 1a. The basic model of wind turbine [27, 28]

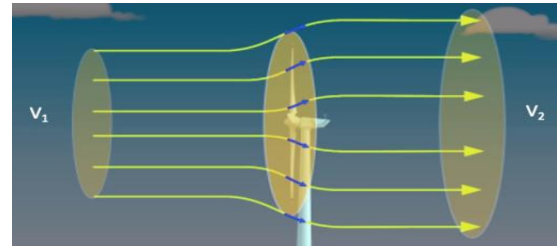

Figure. 1b. Betz flow tube law for wind turbine power generation [27, 28]

By Betz law as shown in Figure 1b, the mechanical power by wind turbine is defined as the equivalent surface to the active surface  $S$  of the wind turbine:

$$P_r = \frac{1}{2} \sigma S V^3 = \frac{1}{2} \pi \sigma R^2 V^3 C_p(x_1, x_4, V). \quad (1)$$

When this paper uses air density  $\sigma = 1.225 \text{ kg/m}^3$ , the value of equation (1) for the specified value is given by

$$P_m = \frac{16}{27} P_r = 0.59 P_r. \quad (2)$$

Equation (2) means that the maximum energy by wind turbine cannot exceed 59% of the wind kinetic energy. That is, a wind generator can never exceed 59% of the kinetic energy of wind. Therefore, the theoretical maximum power coefficient is defined by

$$\Phi_p^{max}(\mu, \varphi) = \frac{P_m}{P_v} = \frac{2P_m}{\sigma S V^3} \leq 0.59. \quad (3)$$

Where, the blade tip speed to wind speed (speed ratio)  $\mu$  can be defined as

$$\mu = \frac{R S_{rot}}{V_v}. \quad (4)$$

$S_{rot}$  is rotational speed before gear box. Maximum power is determined by coefficient  $\Phi_p^{max}$  that represents aerodynamic efficiency of wind turbine. It is determined the characteristics of the turbine. This coefficient is characterized by the speed ratio  $\mu$  and the blade angle  $\varphi$ .

In Figure 1b, when the first step of rotor speed  $V_1$ , the rotor downstream speed  $V_2$ , the average speed  $V$ , and the air density  $\sigma$  are defined, the power conversion is given by  $C_p$ , which is wind turbine efficiency.

That is,  $C_p$  is the actual electric power ratio generated by wind turbine.

*Wind Turbine modeling*

The wind turbine converts the kinetic energy of the wind into torque by rotation of rotor as shown in Figure 2. Where, three factors (radius of the wind generator R, rotational speed  $S_{rot}$ , the maximum power coefficient  $\Phi_p^{max}$ ) determine the ratio of energy conversion. That is, mechanical power is determined by the air density, the rotor's sweeping area, and the wind speed. Air density and wind speed are determined from weather condition.

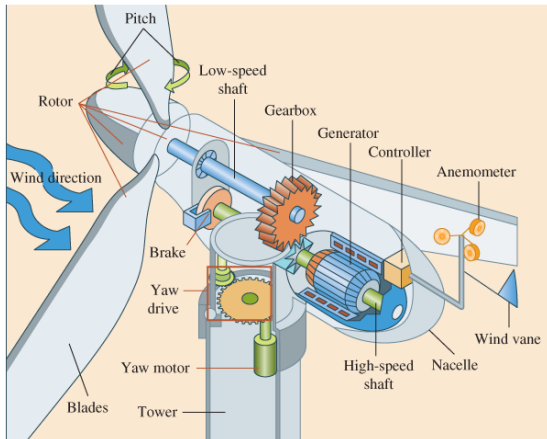

**Figure. 2. Wind turbine structure for modeling [28, 29, 50]**

The power coefficient is specific to each wind turbine based on parameters measured under the designed wind turbine. Therefore, the power coefficient is defined by the following equation [1,2,3, 27, 28] as shown in Figure 2 and equation (5):

$$\Phi_p^{max}(\mu, \varphi) = 0.5176 \left( \frac{116}{\mu_i} - 0.4\varphi - 5 \right) e^{-\frac{21}{\mu_i}} + 0.0068\mu$$

$$\frac{1}{\mu_i} = \frac{1}{\mu + 0.08\varphi} - \frac{0.035}{\varphi^3 + 1}$$

(5)

Using Figure 2 and equation (1) and equation (5), power coefficient can be summarized as

$$\Phi_p^{max}(\mu, \varphi) = \frac{P_m}{P_v} = \Phi_p(\mu, \varphi) \frac{1}{2\sigma\pi R^2 v_i^3}$$

(6)

Because the gear box strongly links between the turbine and the generator, it should adapt from the fastest speed of the generator to the slowest of the turbine. Therefore, it is modeled by the two following equations [1, 27, 28]:

$$S_{rot}^{max}(\mu, \varphi) = \frac{P_{ave}}{G_v}$$

(7a)

$$\Phi_p^{max}(\mu, \varphi) = \frac{P_{ave}}{G_v}$$

(7b)

By using inertial, the generator shaft is modeled by the following equation:

$$J \frac{dS_{rot}}{dt} - \Sigma C = T_{tor} - C_{fir}$$

$$C_{fir} = f S_{rot}$$

(8)

Where, J is the total inertia,  $C_{fir}$  is viscous frictional torque.

The total torque ( $T_{tor}$ ) which equals the superposition of the generator and electromagnetic torques is defined as

$$J \frac{dS_{rot}}{dt} + f S_{rot} = S_{rot} = C_{fir} - C_{em}$$

(9)

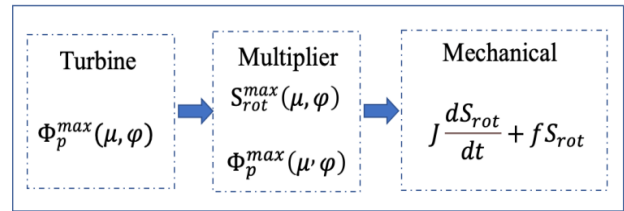

**Figure. 3. Wind turbine modeling structure [3, 5]**

Figure 3 shows that wind turbine has many parameters such as turbine parameter, generator parameter, generator parameter. to monitor and control.

Usually, the wind speed is not uniform across the rotor plane and when instantaneous wind fields are analyzed near the rotor plane, the wind input varies in space and time over the rotor plane itself. The deviations of the wind speed from the nominal wind speed across the rotor plane.

*Pitch System Modeling of Wind Turbine*

The pitch model can be expressed by simply. However, this paper illustrates by using the state space model of the pitch for monitoring easily, which system is given as [10, 11];

$$\begin{bmatrix} \dot{\theta} \\ \dot{\theta} \end{bmatrix} = \begin{bmatrix} 0 & 1 \\ -\omega_n^2 & -2\xi\omega_n \end{bmatrix} \begin{bmatrix} \theta \\ \dot{\theta} \end{bmatrix} + \begin{bmatrix} 0 \\ \omega_n^2 \end{bmatrix} \theta_r$$

(14a)

$$y = \begin{bmatrix} 1 & 0 \\ 0 & 1 \end{bmatrix} \begin{bmatrix} \theta \\ \dot{\theta} \end{bmatrix}$$

(14b)

and its response is defined by 2<sup>nd</sup> system;

$$\frac{\theta(s)}{\theta_r(s)} = \frac{\omega_n^2}{s^2 + 2\xi\omega_n(s) + \omega_n^2}$$

(15)

where  $\omega_n$  is the frequency ration and  $\xi$  is damping ratio and  $\theta(s)$  and  $\theta_r(s)$  are pitch angle and the reference of pitch angle signal. The equation (15) means that the pitch angle system of wind turbine can be expressed by 2nd system response. By using equation (15), we can analyze and simulate the characteristics of pitch angle system like the general automatic control system. Therefore, it is quite important to find what modelling and control aspects will be useful to have an efficiency and reliability. Consequently, a proper mathematical expression method of wind energy conversion leads to the control and monitoring system design and we must recognize the importance of control and monitoring strategy. Herein, this paper suggests on neural network and operation data-based monitoring approach.



## B. State Equation of Wind Turbine Dynamic Model

The state expression of the model is shown in the form as follows [7,8]:

$$\dot{X} = A(x) + B(u) = \begin{bmatrix} A_1 \\ A_2 \\ A_3 \\ A_4 \end{bmatrix} + \begin{bmatrix} 0 \\ 0 \\ 0 \\ B_4 \end{bmatrix} u. \quad (10)$$

Where, state vector  $\dot{X}$ , input vector  $u$ , system vector  $A(x)$  are given as:

$$X = [\alpha, \beta, \gamma, \delta]^T, \quad u = \delta_i. \quad (11)$$

$$A(x) = \begin{bmatrix} P(x_1, x_4) - \frac{x_1 D_s}{J_r} - \frac{x_2 D_s}{N_g J_r} + \frac{x_3 K_s}{J_r} - \frac{x_3 K_s}{J_r} \\ \frac{(x_1, D_s)}{N_g J_g} - \frac{x_2 D_s}{N_g^2 J_g} + \frac{x_3 K_s}{N_g J_g} - \frac{T_g}{J_g} \\ X_1 - \frac{x_2}{N_g} \\ -\frac{1}{t_i} X_4 \end{bmatrix} \quad (12)$$

$$B = \begin{bmatrix} 0 \\ 0 \\ 0 \\ \frac{1}{t_i} \end{bmatrix}. \quad (13)$$

This state equation can be used signal failure status of components of wind turbine. When we use this state equation, we can see clearly relation between components and link status of all component parameters and find out which component signal failure.

## IV. FAILURE PREDICTION BY NEURAL NETWORK AND OPERATION DATA

Figure 4 and Figure 5 show a novel method to predict failures of wind turbine system described in this paper.

This paper suggests the two steps for failure prediction: First step is parameter decision and second step is neural network design.

### A. Parameter Selection

This paper selects the parameter mechanical data (shaft speed, pitch angle variation), the wind data (wind speed, wind direction, air density), and reference data to monitor as shown in Figure 5a. Reference data can offer many references value, which is depending on designer's decision, to monitor. However, this paper uses only pitch angle reference data to simulate.

### B. Design of Neural Network Structure

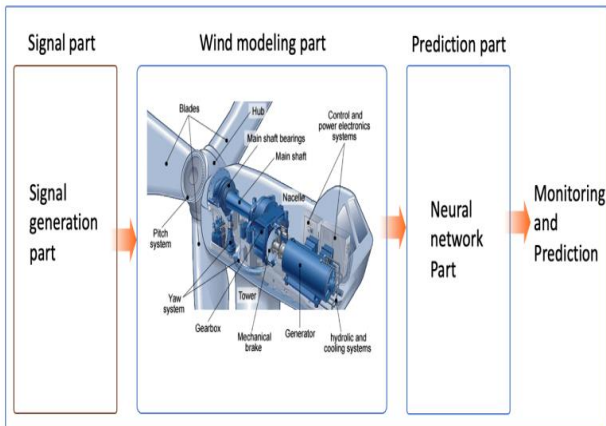

Figure 4a. Wind structure for prediction by NN

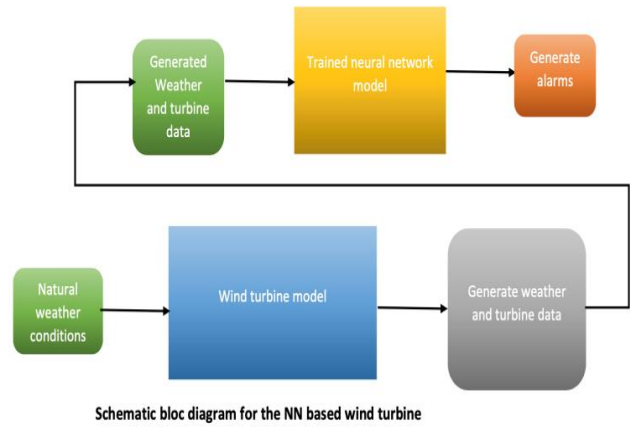

Figure 4b. Prediction signal procedure of neural network for Wind structure

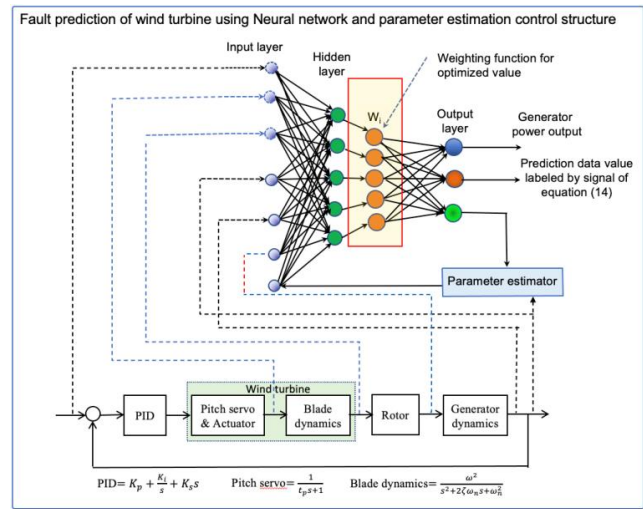

Figure 5a. The neural network structure for prediction

The structure of neural network used in this paper is as shown in Figure 5a. To train this neural network, firstly, we should decide input of neural network. This paper uses mechanical parameters (pitch and actuator error), generator parameter (electrical power, frequency) parameter estimator (wind data, generator final produce value, neural network data) from control system. Second step is to design neural network which input is useful to monitor and how many hidden layer, and what output is better to monitor as shown in Figure 5a. Item of input used in this paper for input of neural network as shown Figure 5a.

This paper uses 40 hidden neurons, with logsig-trainlm and purelin training functions, the data acquired for this training is as shown in Figure 5a.

Final outputs (or target) of neural network are: True or false (Logical 1 and 0 outputs) for failure/fault scenarios predictions and the predicted power out.

This paper adjusts training gain of neural network till summarized error reaches signal through MAE (Root Mean Square) as shown in equation (14).

$$MAE = \frac{1}{n} \sum_{i=1}^n |x_i - \bar{x}| \quad (14)$$

Figure 5b shows the training process of neural network under Matlab tool.

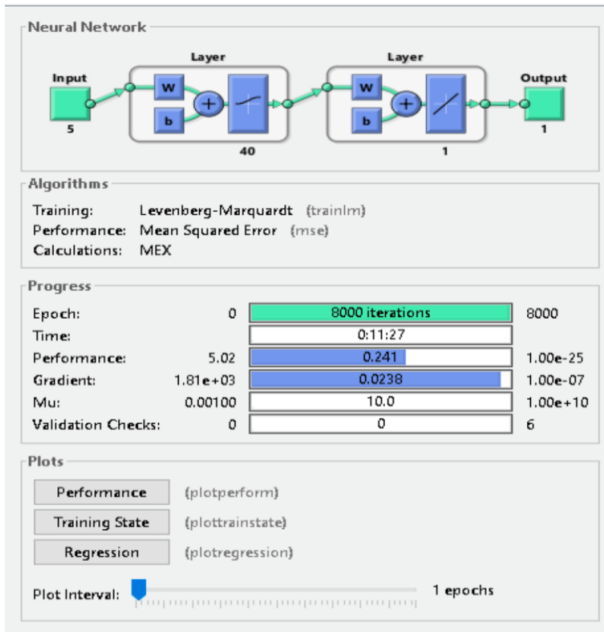

Figure 5b. The neural network structure of Matlab

V. SIMULATION AND RESULTS

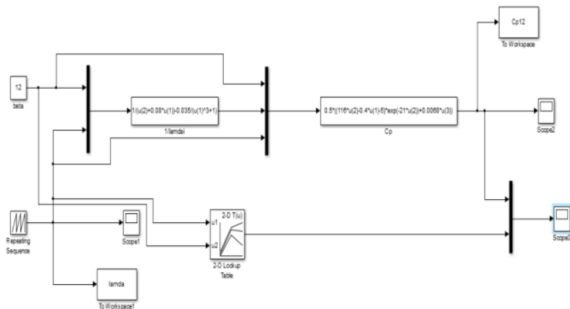

Figure 6. The Simulink structure of aerodynamic model built based on Figure 2b and Figure 3

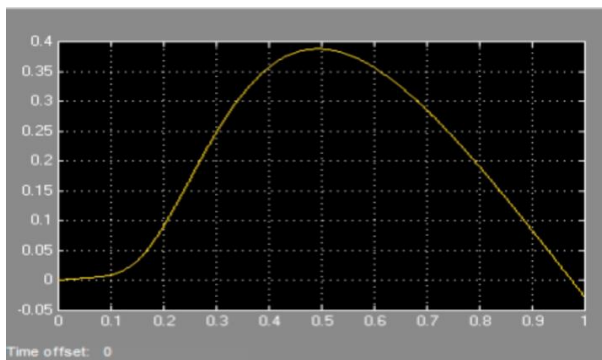

Figure 7. The curve of  $C_p$  to pitch angle=2

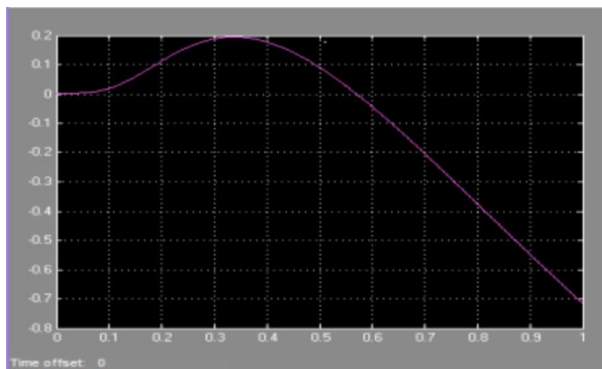

Figure 8. The curve of  $C_p$  to pitch angle=12

This paper suggests and simulates the structure a novel methodology to predict using neural network and operation data.

Figure 6 is Simulink structure built from Figure 2b and Figure 3. Figure 7 and 8 shows the curve to variation of  $C_p$  used equation described in section III.

Figure 9 and 10 represents the data of the different yield graphs when we change pitch angle and speed ratio. We change the value of inputs of beta where pitch angle= 2,4,6,8,10,12. We introduce the different values of  $C_p$  as shown in the Figure 10.

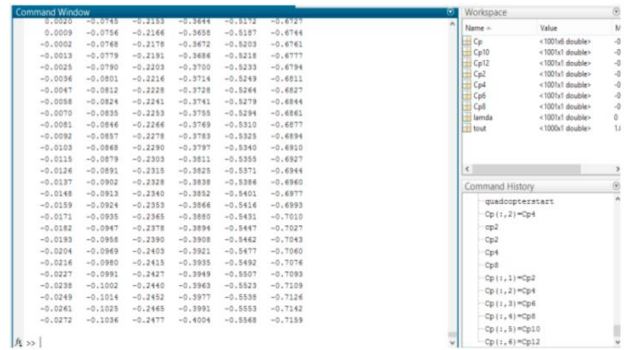

Figure 9a. The data of speed ratio and  $C_p$ .

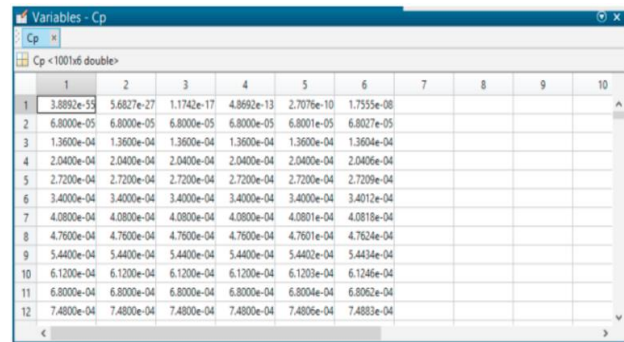

Figure 9b. The data of speed ratio and  $C_p$ .

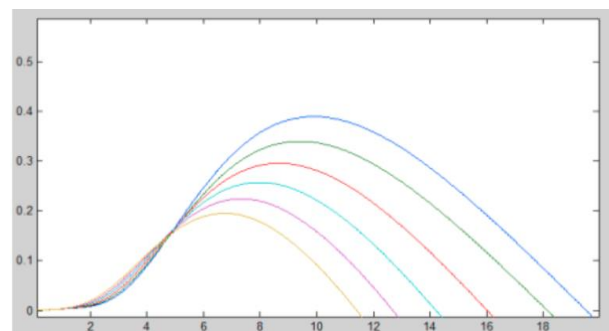

Figure 10. Power coefficient vs. speed ratio for different pitch angle ( $\delta$ )

In Figure 10, there are several curves distinguished depends on speed ratio and pitch angle but this paper focuses on the one curve with the highest peak. This curve is shown by Power coefficient vs. speed ratio for different pitch angle ( $\delta$ ). It means that when we change pitch angle, we can obtain the maximum power of wind energy.

Figure 11 illustrates the curve of real time wind speed and Figure 12 shows mechanical speed (turbine speed).

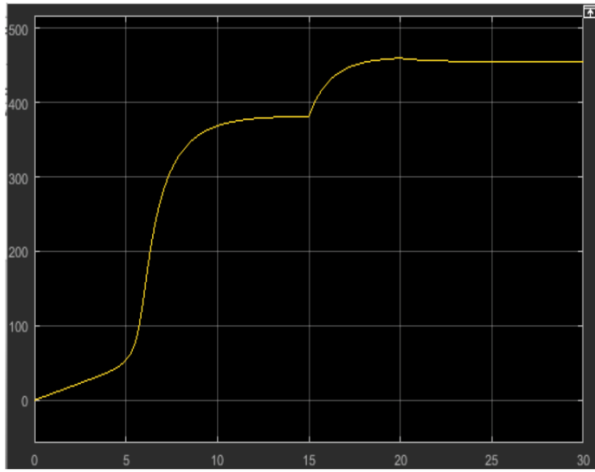

Figure 11. The curve of real time wind speed (m/s)

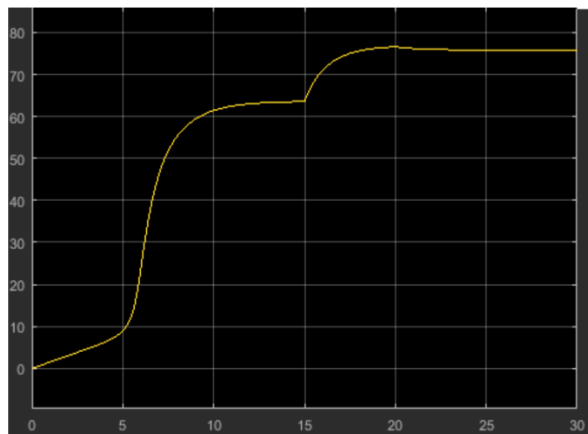

Figure 12. The curve of turbine speed (mechanical speed) m/s

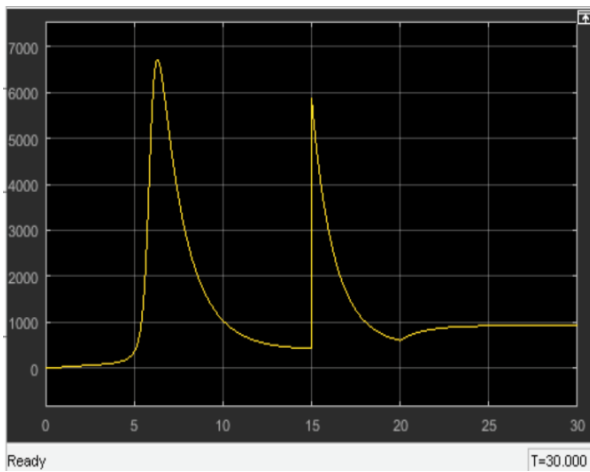

Figure 13. Power produced by wind turbine (MW)

Figure 13 represents the power produced by wind turbine system used in this paper. The corresponding results of the mechanical speed show that the variations of the mechanical are adapted to the variation to wind speed. It means that wind energy transfers to mechanical power well but it shows a relatively slow response with respect to its variations (which validate the Betz law).

Figure 11-13 shows well this paper's model value for training data of Figure 5 has proper value.

Figure 14 shows the overall Simulink structure of prediction system including neural network built in this paper.

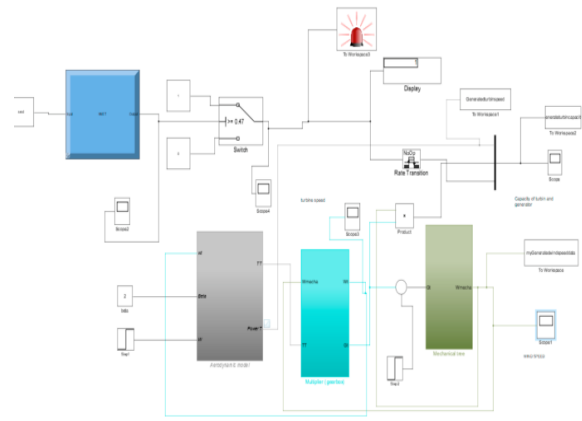

Figure 14. The overall Simulink Structure of Prediction System Including Neural Network

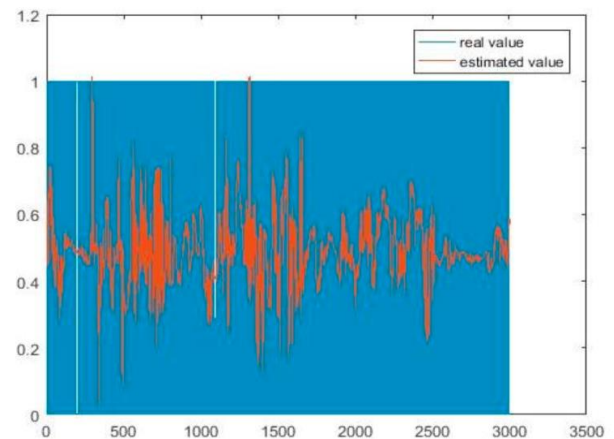

Figure 15. The training process of the neural network of Figure 5

Figure 15 shows training shape of neural network of Figure 5. Figure 16 presents signal status of failure produced by neural network and Figure 17 shows logic table of failure prediction signal produced equation (14). As we can see from Figure 17, signal classifies as digital of 'Yes' or 'No' and signal lamp to express easily.

## VI. CONCLUSION

This paper proposes prediction method to components failure of wind turbines using the neural network and operation signal of control system.

By using available operation data (signal), the neural network trains to make predictions that reflect what normal operating condition of turbine would be useful, which input of the neural network depends on wind situation as shown in Figure 5a.

In case of monitor system, we can monitor system by using data and signal for system fault but we can do it by using control signal.

Especially, when we can estimate parameter of control system, it is quite good to monitor because we can find fault status of control signal. That is this paper's final purpose to obtain better monitoring system.

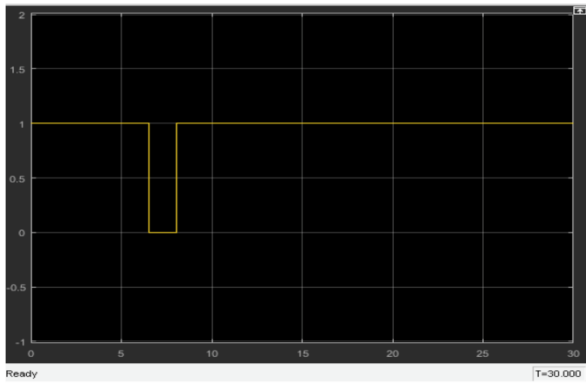

Figure 16. Alarm signal by the neural network

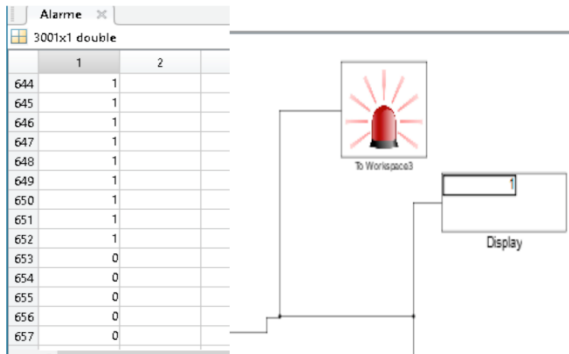

Figure 17. Actual signal and data variation of prediction system by the neural network

There are many components in wind turbine such as sensors, actuators, converter, mechanical driver, computer, software, and others. Additionally, wind turbine sites locate in long distance and offshore. Therefore, its maintenance and operating trust system are quite important to make an efficiency. That is, the reliability of wind turbine should be assumed for the energy conversion capacity and clean energy uses. By taking into account this importance for wind turbines and operating system, this paper studies prediction system that control engineering and monitoring are more competitive and effective through neural network training of operation data. The prediction should produce announcement on what the channel (component) is abnormal behavior of wind turbine at an instant time and this prediction is compared to the actual measured value to trust operating system. However, operator cannot measure during operation easily because of difficult environment of wind turbine. If there are some differences in the data of prediction system as neural network input, it means the measured value is out of the normal operating range or system and it can be a potentially fault. The alerts generation module of neural network designed of this paper is available to express how much the measured value is deviating from the predicted normal behavior and then generates alerts to announce the operator something might be wrong.

**ACKNOWLEDGEMENT**

This works was supported by the National Research Foundation of Korea (NRF) grant funded by the Korea government (MSIT) (No. 2021056145). Author thanks to support of Korea government (MSIT).

**REFERENCES**

1. Ayman A. Nada, Ali S. Al-Shahrani, "Shape Optimization of Low Speed Wind Turbine Blades using Flexible Multibody Approach," Energy Procedia 134, 577–587, 2017.
2. Mahmoud Huleihil and Gedalya Mazor, " Wind Turbine Power: The Betz Limit and Beyond," Additional information is available at the end of the chapter <http://dx.doi.org/10.5772/52580>, 2012.
3. Ioan CURTU et al, "ANALYSIS OF WIND TURBINE BLADES FROM LIGNOCELLULOSIC COMPOSITES SUBJECTED TO STATIC BENDING," ONLINE ISSN 2069-7430 ISSN-L 1841-4737, PRO LIGNO Vol. 11 N° 4 2015 [www.proligno.ro](http://www.proligno.ro) pp. 157-164.
4. Liu, G. P., & Daley, S., "Optimal-tuning PID controller design in the frequency-domain with application to rotary hydraulic systems," Control Engineering Practice, 7, pp. 821–830, 1999.
5. Dong Hwa Kim, Jin Ill Park, "Intelligent PID Controller Tuning of AVR System Using GA and PSO," IEEE 2005 Intelligent computing, Lecture Notes in Computer Science Proceeding of Springer (SCI), Aug. 23-26, 2005.
6. Silvio Simani\*, Stefano Alvisi, Mauro Venturini, " Overview of Modelling and Control Strategies for Wind Turbines and Hydroelectric Systems: Comparisons and Contrasts," 20944/preprints201708.0034.v1.
7. Ayse Gokcen Kavaz and Burak Barutcu, " Fault Detection of Wind Turbine Sensors Using Artificial Neural Networks," Journal of Sensors Volume 2018, Article ID 5628429, 11 pages, 2018.
8. Altin, Müfit; Hansen, Anca Daniela; Gökso, Ömer; Cutululis, Nicolaos Antonio; Sørensen, Poul Ejnar, "Wind Turbine and Wind Power Plant Modelling Aspects for Power System Stability Studies," Wind energy Grid-Adaptive Technologies 2014, 20–22 October, 2014.
9. Lei Wang et al, "Active Fault-Tolerant Control for Wind Turbine with Simultaneous Actuator and Sensor Faults," Complexity Volume 2017, Article ID 6164841, 11 pages, <https://doi.org/10.1155/2017/6164841>.
10. Francesco Castellani, " SCADA Data Analysis Methods for Diagnosis of Electrical Faults to Wind Turbine Generators," Appl. Sci. 2021, 11, 3307. <https://doi.org/10.3390/app11083307>.
11. B. Corley, J. Carroll, A. McDonald, "Fault detection of wind turbine gearbox using thermal network modelling and SCADA data," Journal of Physics: Conference Series 1618 (2020) 022042 doi:10.1088/1742-6596/1618/2/022042.
12. Francesc Pozo et al, "Wind Turbine Condition Monitoring Strategy through Multiway PCA and Multivariate Inference," Energies 2018, 11, 749; doi:10.3390/en11040749.
13. Kevin Leahy et al, "A Robust Prescriptive Framework and Performance Metric for Diagnosing and Predicting Wind Turbine Faults Based on SCADA and Alarms Data with Case Study," Energies 2018, 11, 1738; doi:10.3390/en11071738.
14. Yingying Zhao et al, "Fault Prediction and Diagnosis of Wind Turbine Generators Using SCADA Data," Energies 2017, 10, 1210; doi:10.3390/en10081210.
15. Wenxian Yang et al, "Wind turbine condition monitoring by the approach of SCADA data analysis," Renewable Energy 53 (2013) 365e376.
16. Joyjit Chatterjee, "Temporal Causal Inference in Wind Turbine SCADA Data Using Deep Learning for Explainable AI," Journal of Physics: Conference Series 1618 (2020) 022022 doi:10.1088/1742-6596/1618/2/022022.
17. Vasishta Bhargava et al, "Acoustic Emissions from Wind Turbine Blades," J. Aerosp. Technol. Manag., São José dos Campos, v11, e4219, 2019.
18. Jialin Tang et al, "A Pattern Recognition Approach to Acoustic Emission Data Originating from Fatigue of Wind Turbine Blades," Sensors 2017, 17, 2507; doi:10.3390/s17112507.
19. Yasir Hassan Ali et al, "Acoustic Emission Signal Analysis and Artificial Intelligence Techniques in Machine Condition Monitoring and Fault Diagnosis: A Review," Jurnal Teknologi · June 2014.
20. Dimitrios Papasalouros et al, "Acoustic Emission Monitoring of Composite Blade of NM48/750 NEG-MICON Wind Turbine," J. Acoustic Emission, 31 (2013).
21. Simon J. Watson et al, "Condition Monitoring of the Power Output of Wind Turbine Generators using Wavelets," IEEE Transactions on Energy Conversion · October 2010.

22. Yasir Saleem Afridi et al, "Artificial Intelligence Based Prognostic Maintenance of Renewable Energy Systems: A Review of Techniques, Challenges, and Future," 04 2021.
23. Haroon Rashid et al, "Anomaly Detection of Wind Turbine Gearbox based on SCADA Temperature Data using Machine Learning," [oi:10.20944/preprints202101.0356.v1](https://doi.org/10.20944/preprints202101.0356.v1).
24. Shen Zhang, "Deep Learning Algorithms for Bearing Fault Diagnostics – A Comprehensive Review," 02 2020.
25. Shahaboddin Shamsirband et al, "Adaptive Neuro-Fuzzy Methodology for Noise Assessment of Wind Turbine," PLOS ONE, July 2014 | Volume 9 | Issue 7 | e103414.
26. Ziqiao Liu et al, "Wind Power Plant Prediction by Using Neural Networks," NREL Report, 2012.
27. Mahmoud Huleihil and Gedalya Mazor, "Wind Turbine Power: The Betz Limit and Beyond," INTECH, Book, Ch 1, 2012.
28. Ayman A. Nada et al, " shape optimization of Low Speed Wind Turbine Blades using Flexible Multibody Approach," Energy Procedia 134 (2017) 577–587.
29. Dong Hwa Kim, "Advanced Lecture for PID Controller of Nonlinear System in Python", IJRTE (ISSN 2277-3878). Vol-9 Issue-6, pp. 20-29, March 2021. It will be appeared in the journal website between 30 March 2021 to 05 April 2021 (Scopus).

**Table- I: Description**

Symbol	Description
$\alpha$	Speed of low-speed shaft
$\beta$	Generator speed
$\gamma$	Twist angle
$\delta$	Pitch angle
$\delta_i$	Pitch angle control
$t_i$	Time constant of the pitch actuator
$T_g$	Generator torque
$J_g$	Generator inertia
$J_r$	Low speed shaft inertia
$N_g$	Gear ration
$D_s$	Drive train damping
$K_s$	Spring constant
R	Rotor radius
$\sigma$	Air density
V	Wind speed
$C_p$	Power conversion coefficient

### AUTHORS PROFILE



**Dr. Dong Hwa Kim** Science, Interdisciplinary Graduate School of Science and Engineering (AI Application for Automatic control), TIT (Tokyo Institute of Technology), Tokyo, Japan. He worked ever at the Hanbat National University (Dean, S. Korea), He has experience in many Universities, overseas as Prof. Electrical Power and Control Eng. Adama Science and Tech. Uni. Ethiopia. Vietnam TDT

(Director, establish Korea Expert Center), Mongolian University (Dean, Graduate school). He had ever work as NCP of EU-FP7 (EU-Framework Program, ICT). He had keynote speak at several international conferences and Universities. He has 200 papers in Journal and conferences. He was editor of IJCIR (International Journal of Computational Intelligence) and He is reviewing IEEE and other's Journal.

Home page: [www.worldhumancare.wixsite.com/kimsite](http://www.worldhumancare.wixsite.com/kimsite)

Research citations: [https://www.researchgate.net/profile/Dong\\_Kim53](https://www.researchgate.net/profile/Dong_Kim53)



**Prof. Dr. Young Sung Kim** Professor in the NDT Research Center, Seoul National University of Science and Technology (Seoultech). He worked at Graduating School of Nanoscience, Information, Design and Engineering in Seoultech. His research interest in Material and Nano-Micro Technology. E-mail: [youngsk@seoultech.ac.kr](mailto:youngsk@seoultech.ac.kr).