

Step-Up Dc-Dc Converter for Pv Cell

Mohd Abdul Kareem, Naveen Kumar.D, N Bheemaiah, B Pallavi

Abstract: Paper In modern trend renewable energy sources has taken vast place in power generation. out of all renewable energy sources solar power generation source has high efficiency. in our paper we have using a converter which step up the power generation through photo voltaic cell. Coupled inductor topology not step up input but also provides uninterrupted power supply to load. This type of system is used in island applications. Voltage developed by photo voltaic cell is 15v which is step up to 220V using our proposed converter with power of 100W, this converter provide output which is fifteen times of input. This converter is transformer less and has negligence losses therefore it is DC-DC converter used for DC applications and for Ac applications by connecting an inverter to it.

Keywords: PV module, Continuous Conduction Mode (CMM), DC-DC Converter, CIMP technique, Active switch.

I. INTRODUCTION

In recent years, there has been Associate in Nursing upsurge of interest in star electrical phenomenon (PV) energy systems in each business and domain. In typical PV power generation systems, many electrical phenomenon panels are connected nonparallel Associate in nursing parallel to create an array and feed energy to one centralized electrical converter or to a number of parallel 'string' inverters. An alternate approach is to use Associate in Nursing AC module, that could be a combination of 1 PV panel and one power acquisition unit, to feed power directly into the grid. The advantages of Associate in Nursing AC module primarily based system over systems supported centralized electrical converter or parallel string inverters are as follows:

- 1) The maximum power point (MPP) of each panel can be tracked individually, thereby increasing the utilization of the whole PV system;
- 2) Detrimental effects due to shading and module mismatches are not present.
- 3) Potential arcing problems due to DC system wiring are fully avoided.

However, associate AC module based mostly system includes a few issues conjointly, as well as potential reduction in system potency and potential boost within the overall system price thanks to the employment of many low power inverters. bigger maintenance might also be needed, although overall irresponsibleness may very well improve thanks to the employment of many parallel inverters. Among the variability of circuits and management strategies that are

developed for the AC module application, the fly-back DCM (discontinuous conductivity mode) electrical converter is one among the favored topologies due to its simplicity and potential low price. The element count is low and also the electrical converter needs solely a straightforward management theme.

A. Photovoltaic Technology

Photovoltaic is that the field of technology and analysis associated with the devices that directly convert daylight into electricity. The photovoltaic cell is that the elementary building block of the electrical phenomenon technology. star cells area unit product of semiconductor materials like element. one in all the properties of semiconductors that produces them most helpful is that their conduction might simply be changed by introducing impurities into their Bravais lattice [1].

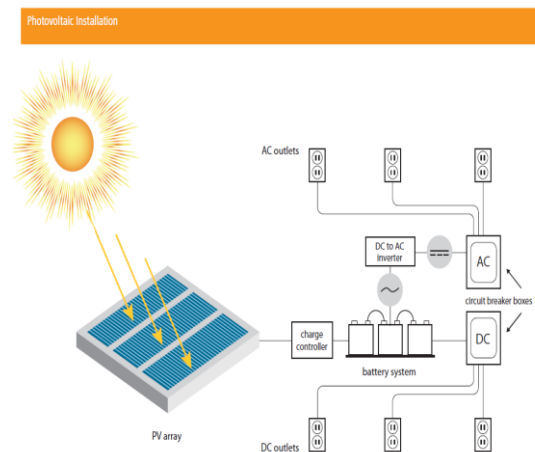

Figure1: photovoltaic installation

II. PROPOSED CONCEPT

Photo voltaic power generation system is more efficient system which is most used in distribution system. PV cell is made up of semiconductor devices which has ability to generate electricity by absorbing photons of sun light and releasing free electrons in it. PV cell always produces DC current which is pulsating in nature. MPP (maximum peak point) vary from 15V to 40V based on temperature of sunlight. Power generated by each PV panel is from 100W to 300W. Constant voltage produced by PV cell is step up using converter which utilizes coupled inductor topology. High dc supply is given to inverter which converts DC to AC, inverter has IGBT switches which are controlled control circuit. Output of inverter is either use to run ac appliances or supply power to grid. Floating active switch is used in our system which is used for two purposes, firstly active switch is used for our smooth operation of converter and make user safety when system is off load [2]. Users touch terminals of converter they may get the shock therefore active switch off the circuit from input and user is safe.

Revised Manuscript Received on February 25, 2020.

* Correspondence Author

Mohd Abdul Kareem*, Electrical and Electronics Engineering Department Siddhartha Institute of Technology & Sciences, Hyderabad Telangana , India. Email: abdulkareemshah@gmail.com

D Naveen Kumar & N Bheemaiah, Electrical and Electronics Engineering Department Siddhartha Institute of Technology & Sciences, Hyderabad Telangana , India. Email: bheem26@gmail.com

B Pallavi, Electrical and Electronics Engineering Department Stanley College of Engineering and Technology for Women, Hyderabad Telangana , India. Email: bpallavi.17@gmail.com

Step-Up Dc-Dc Converter for Pv Cell

Main Features of DC-DC Converter

1. High change in magnitude of output gain
2. No isolation is needed
3. High safety for operating people

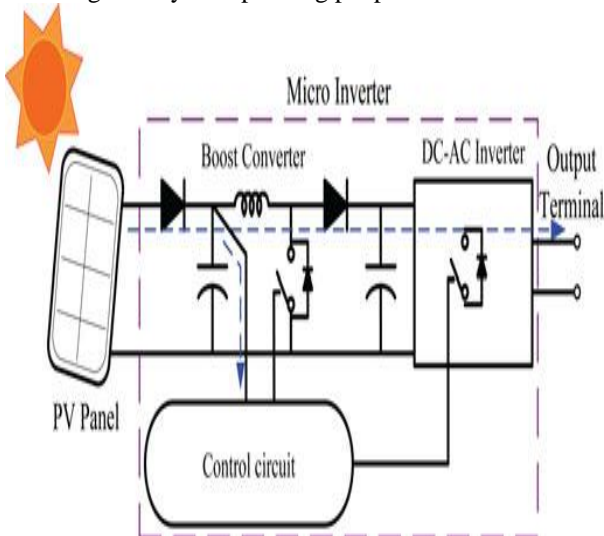

Figure2: Potential difference on the output terminal of non floating switch Micro inverter

III. OPERATING PRINCIPLES OF THE PROPOSED CONVERTER

Simplified circuit is shown in figure 3. Coupling inductor T consists of 2 separate magnetizing inductances Lk1 and Lk2. these inductors release and absorb energy based on switch S1 and other elements of circuit.

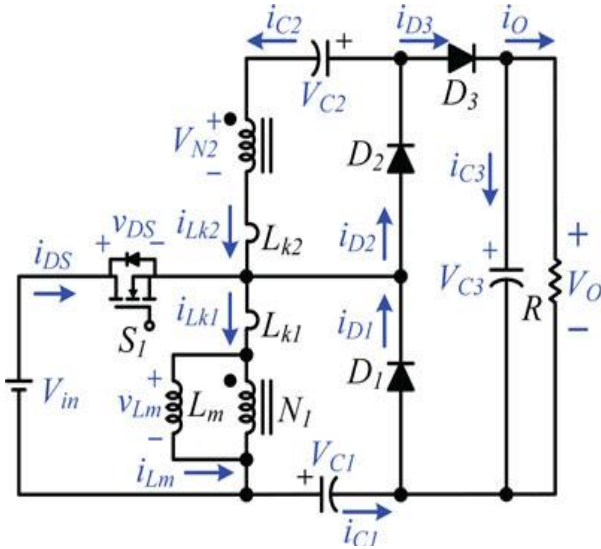

Figure3: Polarity definitions of voltage and current in proposed converter

1. All components are ideal except coupled inductor T. parasitic effect and closed switch resistance is neglected at on instance.
2. Voltage across C1 and C3 is assumed constant
3. ESR of C1 and C3 is neglected
4. Continuous Conduction Mode is discussed in detail

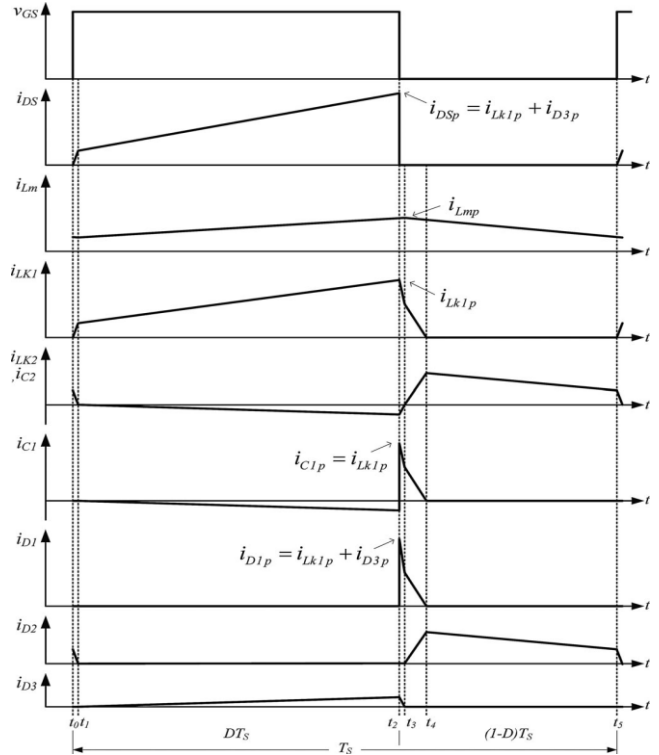

Figure4: Some typical waveforms of proposed converters at CCM operation

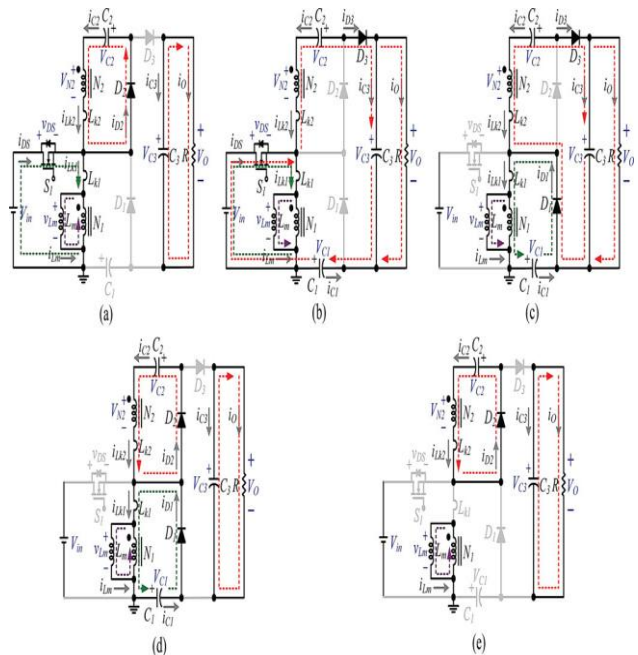

Figure5: CCM operation modes

IV. STEADY-STATE ANALYSIS OF PROPOSED CONVERTERS

A CCM Operation

$$v_{Lm} = V_{in} (1)$$

$$V_{N2} = nV_{in} (2)$$

During mode IV

$$v_{Lm} = -VC1 (3)$$

$$v_{N2} = -VC2 (4)$$

Apply volt-second balance on the magnetize inductor L_m yields

$$\int_0^{DTS} (V_{in}) dt + \int_{DTS}^{(D+DL)TS} (-V_{c1}) dt = 0 \quad (5)$$

$$\int_0^{DTS} (nV_{in}) dt + \int_{DTS}^{(D+DL)TS} (-V_{c2}) dt = 0 \quad (6)$$

From which the volt across capacitors C_1 and C_2 are obtained as follows:

$$V_{c1} = DV_{in}/(1-D) \quad (7)$$

$$V_{c2} = nDV_{in}/(1-D) \quad (8)$$

During mode II, the output voltage

$$V_o = V_{in} + V_{N2} + V_{C2} + V_{C1} \text{ becomes}$$

$$V_o = V_{in} + nV_{in} + nDV_{in}/[1-D] + DV_{in}/[1-D] \quad (9)$$

The DC voltage gain M_{CCM} can be found as follows:

$$M_{CCM} = (V_o/V_{in}) = (1+n)/(1-D) \quad (10)$$

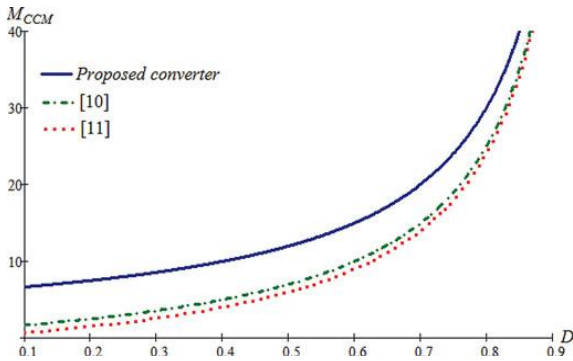

Figure6: Voltage gain as a function of the duty ratio of the proposed converter

All of them are operating under the same conditions: CCM and $n = 5$. During CCM operation, the voltage stresses on S_1 and $D_1 \sim D_3$ are given as

$$V_{DS} = V_{D1} = (V_{in}/1-D) \quad (11)$$

$$V_{D2} = (nV_{in}/1-D) \quad (12)$$

$$V_{D3} = (1+n)V_{in}/1-D \quad (13)$$

B BCM Condition

When the proposed device is operating in boundary conduction mode (BCM), the voltage gains of CCM and DCM operation are equal.

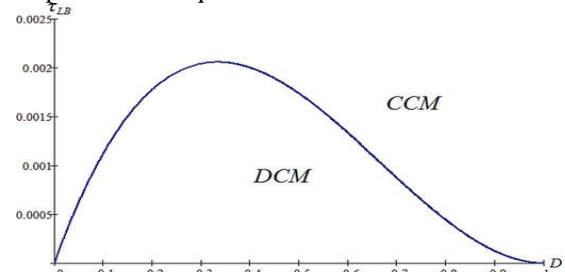

Figure7: Boundary condition of τ_{LB} of proposed converter under $n = 5$

$$T_{LB} = D(1-D)^2/[2(1+n)^2] = D/[2(M_{CCM})^2] \quad (32)$$

The curve of τ_{LB} is plotted in Fig. 10. Once the τ_{Lm} is higher than boundary curve τ_{LmB} , the proposed converter operates in CCM.

The voltages across circuit elements are given along with the currents in the Fig. 11 below.

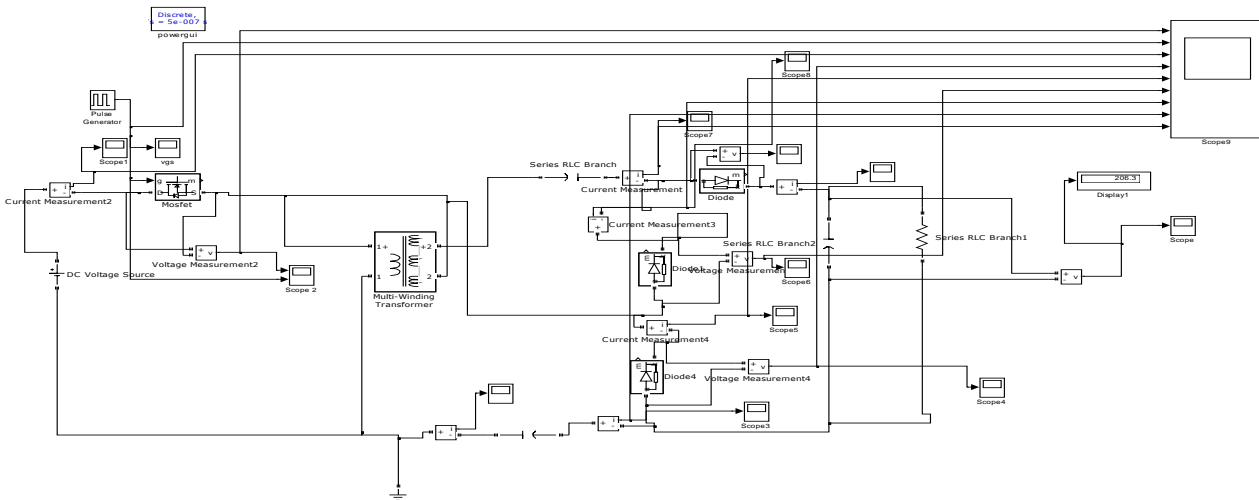

Figure8 : Simulation Circuit

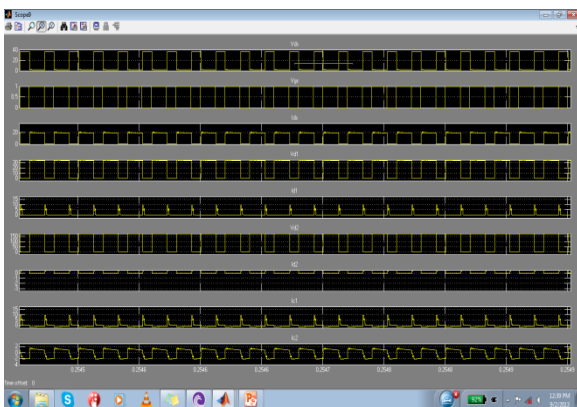

Figure9: Voltages and currents across elements

The output voltage across the proposed converter is given in the Figure10 below.

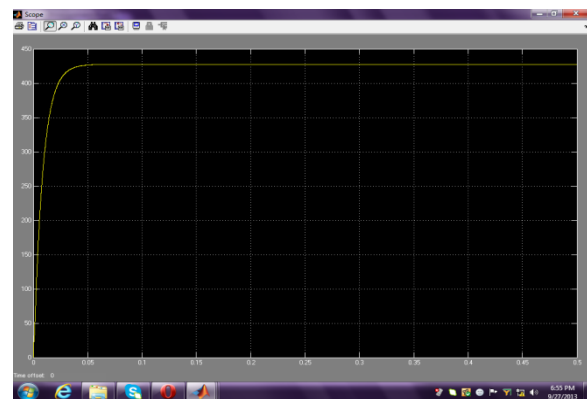

Figure10: Output voltage across proposed converter

V. CONCLUSION

Energy of an recycled inductor is utilized in order to increases the output voltage. Capacitors and diodes provides proper path to leakage current of a coupled inductor. Capacitors store energy in an electric field which it is charge energy during sudden change in voltage. Ron on state resistance of switch is neglected because of very less value. Output voltage of a converter is fifteen times input voltage.

REFERENCES

1. K.-C. Tseng, C.-C. Huang, W.Y. Shih A high step-up converter with a voltage multiplier module for a photovoltaic system IEEE Trans. Power Electron, 28 (6) (2013), pp. 3047-3057
2. E.H. Ismail, M.A. Saffar, A.J. Fardoun A family of single-switch PWM converters with High Step-Up Conversion Ratio IEEE Trans. Cir. and Sys., 55 (4) (2008), pp. 1159-1171 Abbreviations and Acronyms

AUTHORS PROFILE



Mohd Abdul Kareem working Associate Professor, Siddhartha Institute of Technology and Sciences, his area of interest is FACTS, Power converters, Electric Drives. He has published 8 paper's in international journal. He has 8 years of teaching experience.



Naveen Kumar.D working as an Associate Professor, Siddhartha Institute of Technology and Sciences, his area of interest is Power Systems, Renewable Energy Systems



N Bheemaiah working as an Assistant Professor, Siddhartha Institute of Technology and Sciences, his area of interest is Power Converters, Electric Drives.



B Pallavi working as an Assistant Professor, Stanley College of Engineering and Technology for Women, her area of interest is Power Converters, FACTS controllers, Electric Drives