

A New Vertical Tail Design Procedure for General Aviation and Turboprop Aircraft

F. Nicolosi, P. Della Vecchia, D. Ciliberti

University of Naples “Federico II”
Dept. of Industrial Engineering
Aerospace Division

<http://ewade2013.AircraftDesign.org>
<http://dx.doi.org/10.5281/zenodo.546414>

Research motivation

- Tail plane design needs an accurate determination of stability derivatives
- Semi-empirical methods are based on obsolete geometries (NACA '30s to '50s)
- Discrepancies between methods USAF DATCOM and ESDU
- Develop a new reliable procedure for turboprop and commuter airplanes

Effect of the horizontal stabilizer position

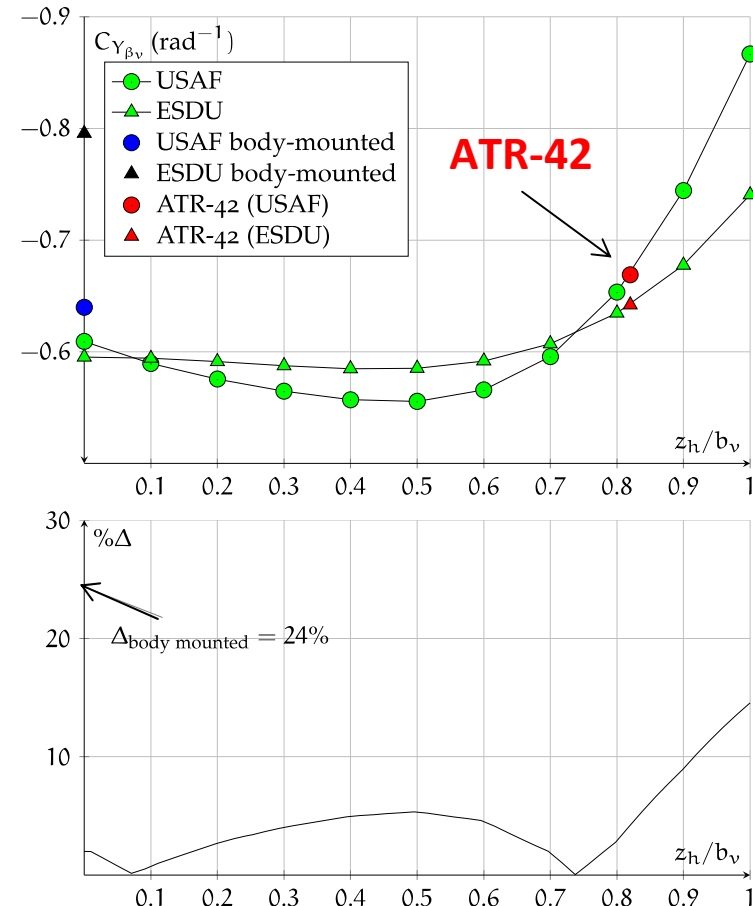

Research motivation (continued)

USAF DATCOM and ESDU procedures for the evaluation of directional static stability derivatives are mainly based on these geometries!

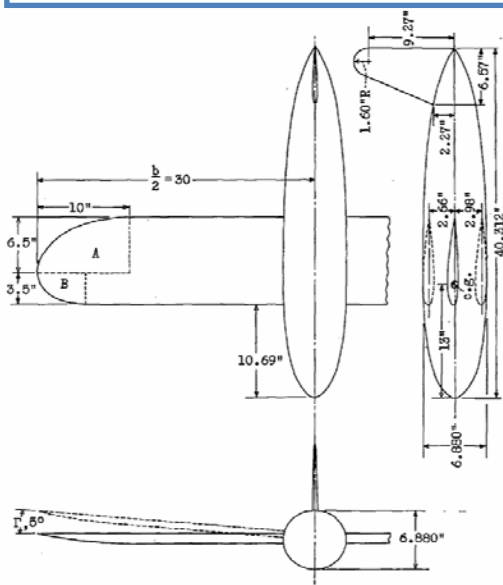

Geometry for the investigation on wing position in fuselage

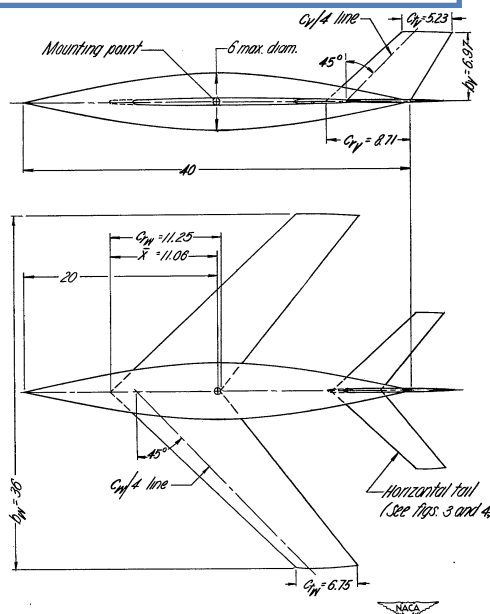

Geometry for the investigation on tail-body interaction

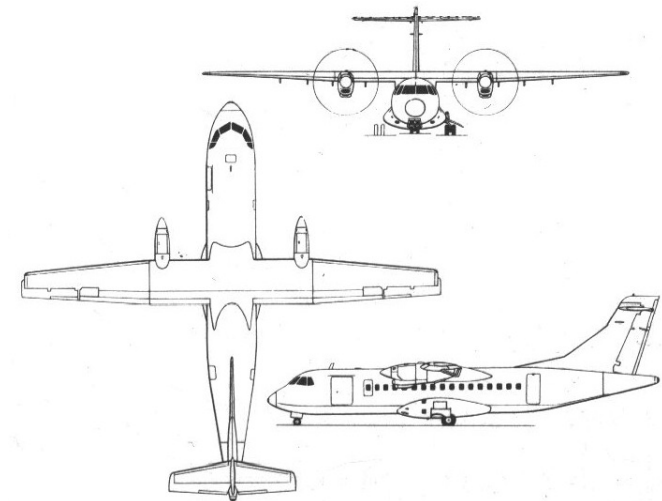

Actual geometries
ATR-42

USAF DATCOM approach

$$C_{L\alpha} = \frac{2\pi A}{2 + \left[\frac{B^2 A^2}{\kappa^2} \left(1 + \frac{\tan^2 \Lambda_{c/2}}{B^2} \right) + 4 \right]^{1/2}}$$

VT effective aspect ratio, sweep angle, Mach number

$$A_{v\text{eff}} = \frac{A_{v(f)}}{A_v} A_v \left[1 + K_{vh} \left(\frac{A_{v(hf)}}{A_{v(f)}} - 1 \right) \right]$$

$$C_{Y\beta} = -k_v C_{L\alpha v} \left(1 + \frac{d\sigma}{d\beta} \right) \eta_v \frac{S_v}{S}$$

$\left(1 + \frac{d\sigma}{d\beta} \right) \eta_v =$ Sidewash (Wing effect)

$$= 0.724 + 3.06 \frac{S_v/S}{1 + \cos \Lambda_{c/4}} + 0.4 \frac{z_w}{z_f} + 0.009A$$

TProp values (ATR-72):

$S_v/S = 0.25, A = 12$

High wing = 1.04

Low wing = 1.44

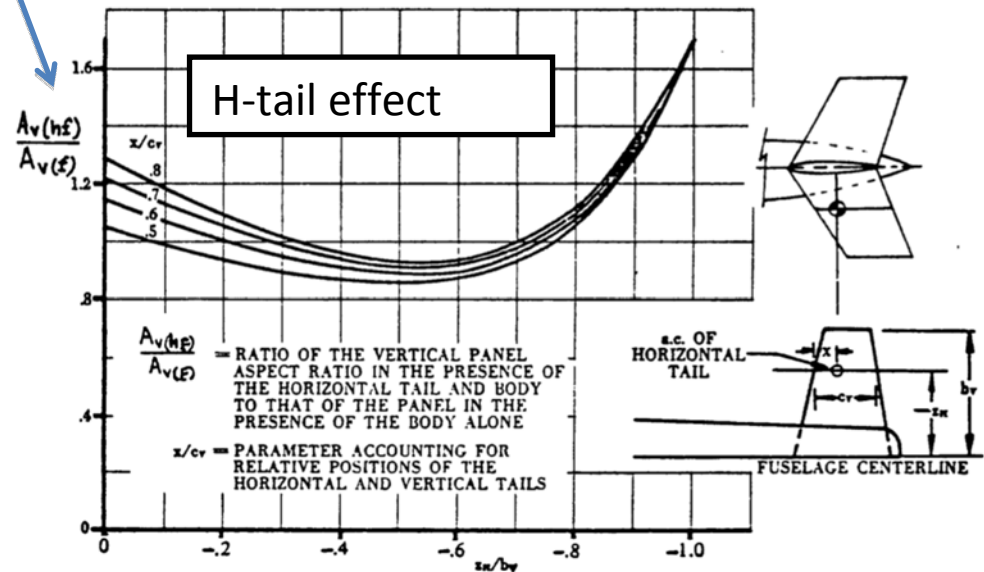
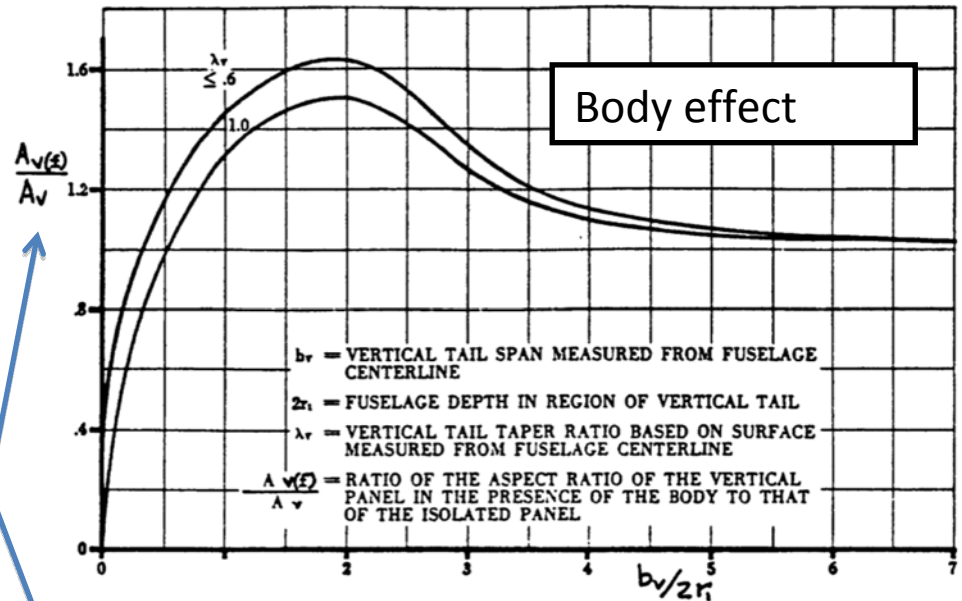

Star-CCM+

CAD import

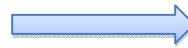
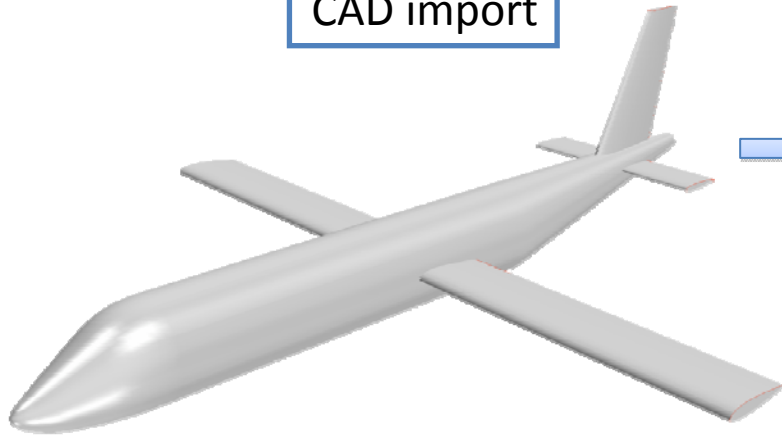

Mesh generation

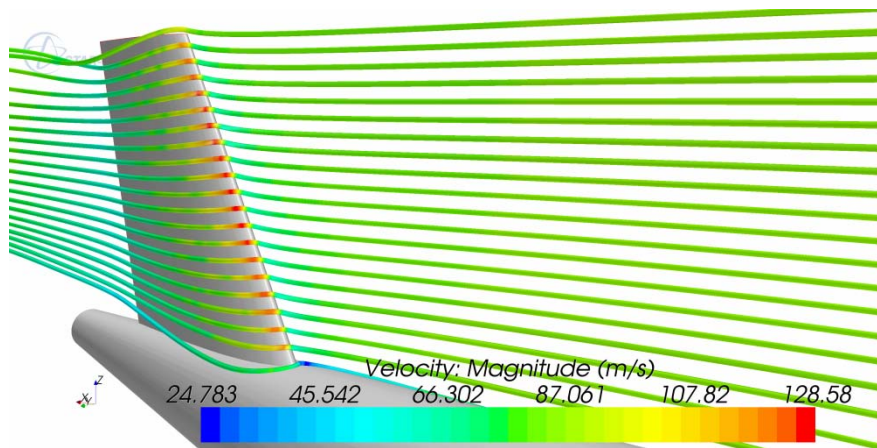
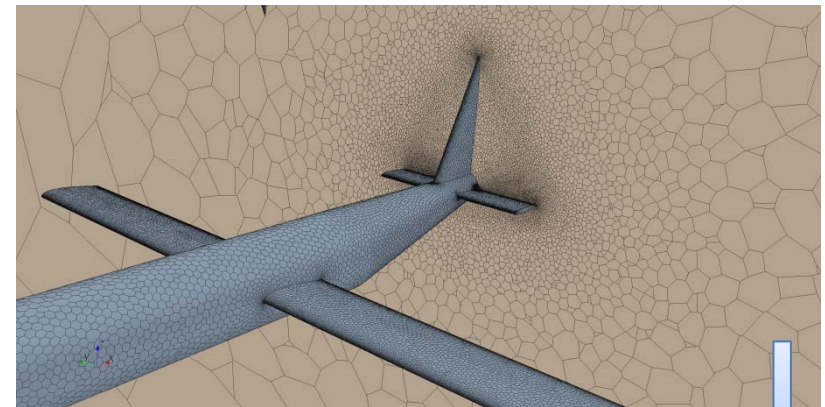

Post-process



Analysis

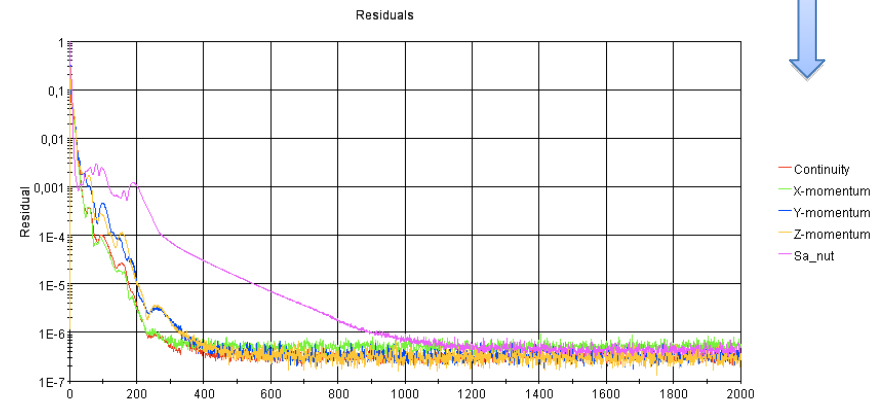

Computing Grid

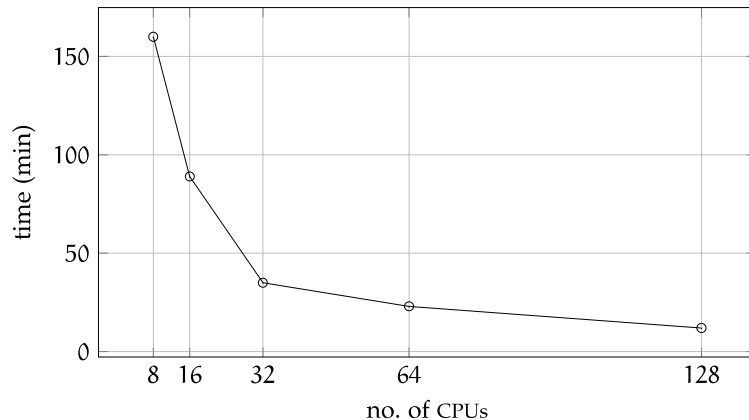

(a) Linear plot.

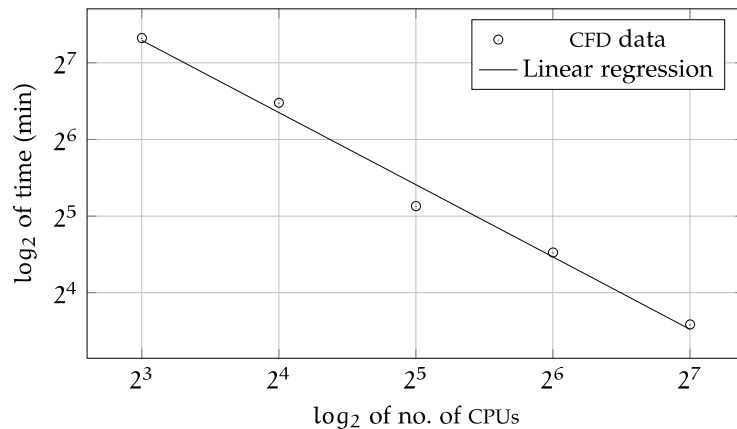

(b) Logarithmic plot.

SCoPE

- University's cluster grid
- Up to 128 CPUs for a single run
- Advice: 1 CPU every 250000 cells
- CPU time (no mesh generation):
 - minutes for partial configurations
 - hours for complete airplane



Convergence

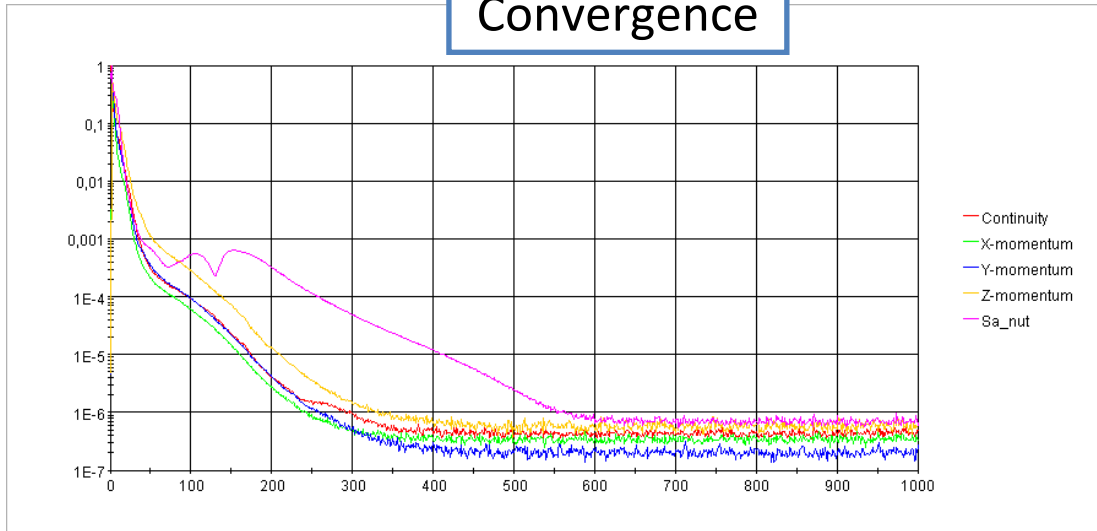

Reports Plot

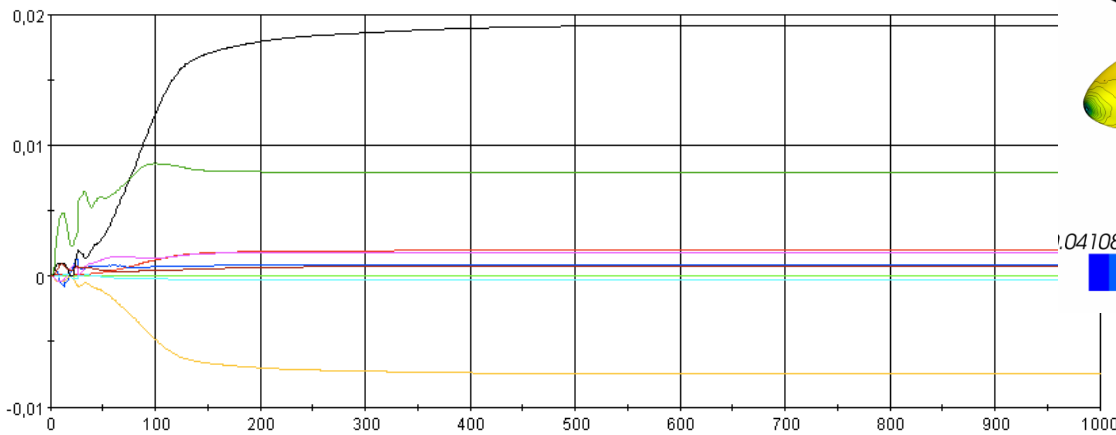

— CL Fin Monitor — CL Fus Monitor — CL Wing Monitor — CN Fin Monitor — CN Fus Monitor — CN Wing Monitor — CY Fin Monitor — CY Fus Monitor — CY Wing

NACA Test cases

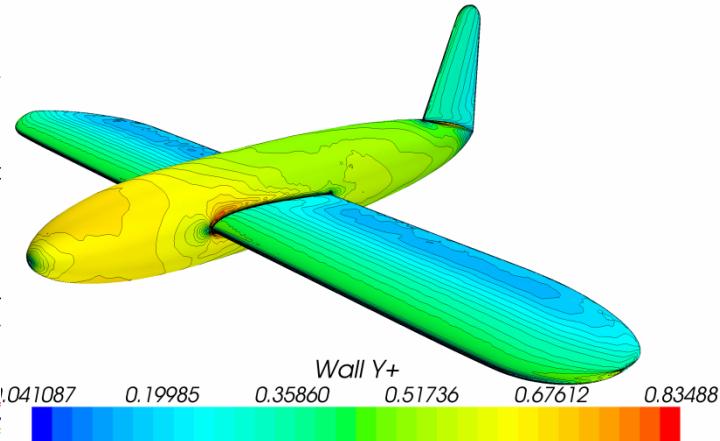
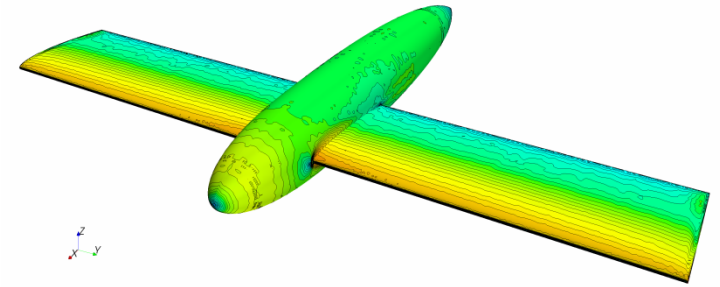
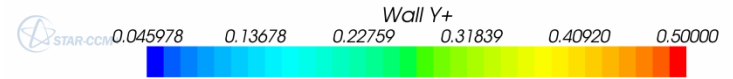

Check of convergence

1. Residuals
2. Aerodynamic coefficients
3. Wall y^+

Test cases – NACA 540

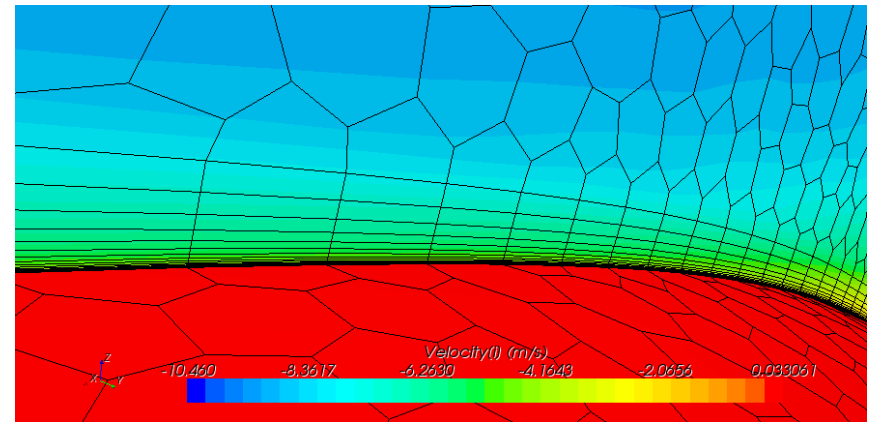
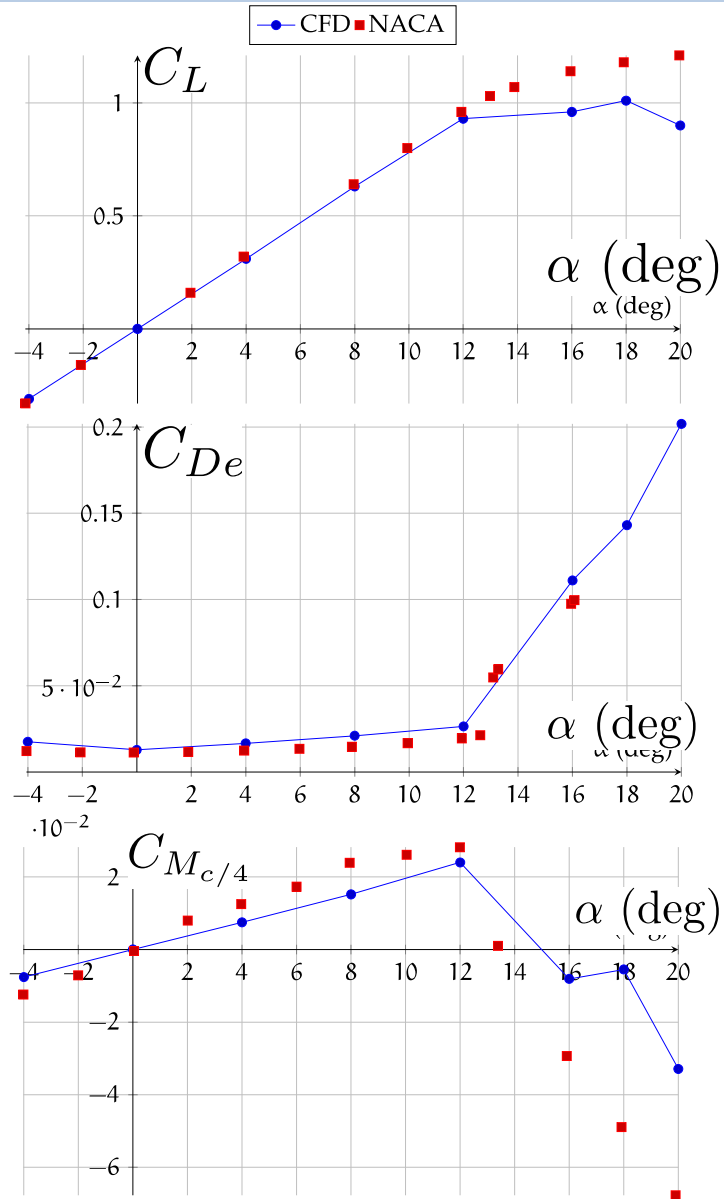
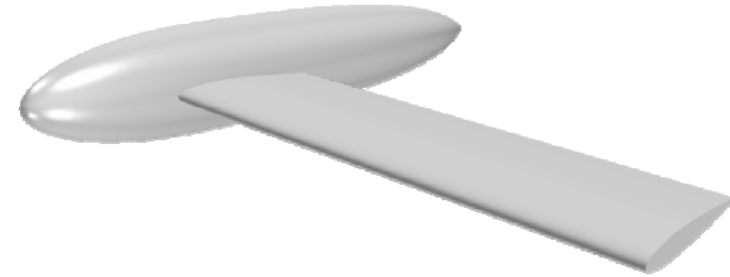

Longitudinal test case
 $A = 6$ $Re = 3\,100\,000$
 no. of cells $\approx 1\,000\,000$

Test cases – NACA 730

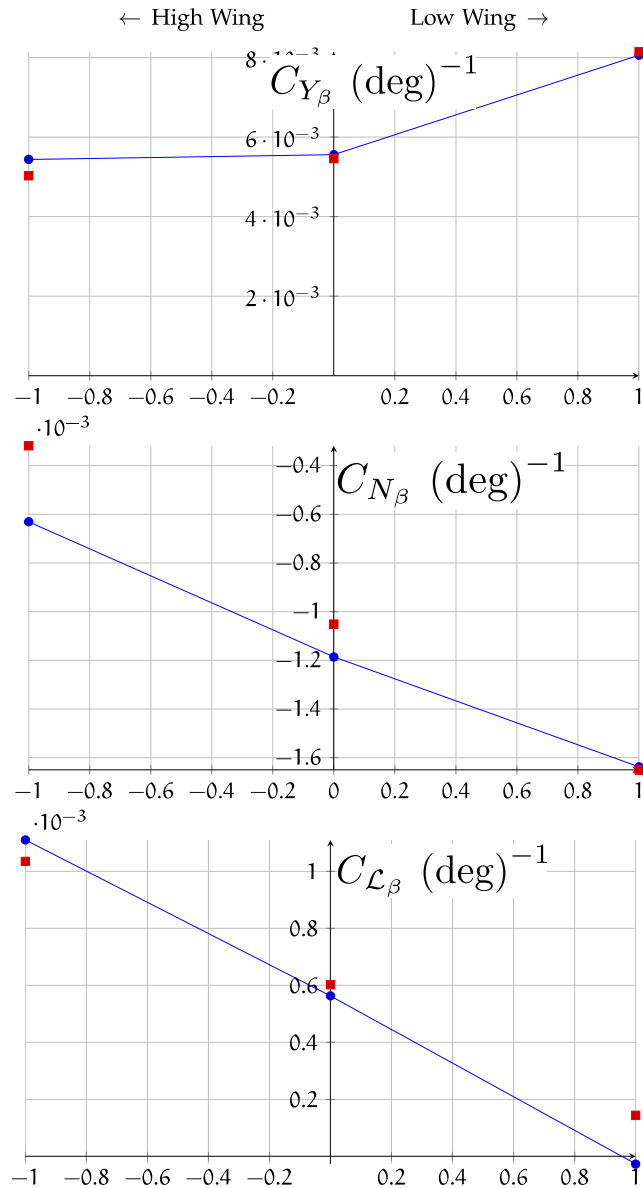
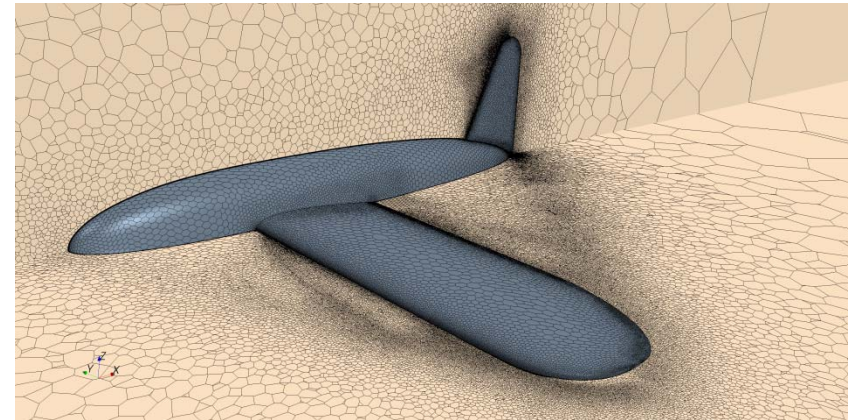
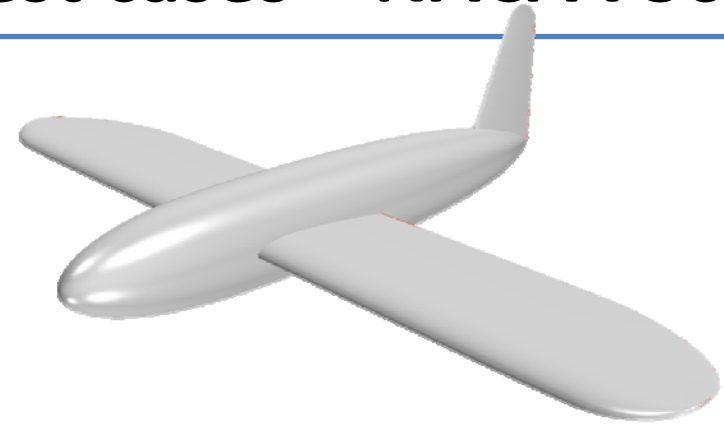

Directional test case
 $\alpha = 0^\circ$ $\beta = 5^\circ$ $Re = 609\,000$
 no. of cells $\approx 5\,000\,000$

Test cases – NACA 1049

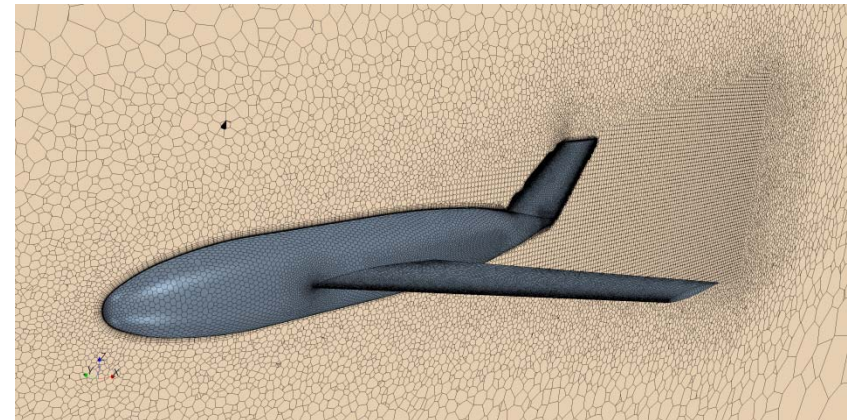
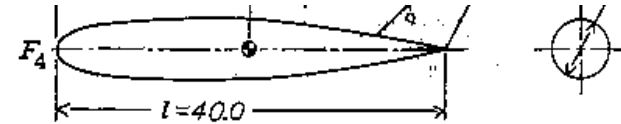
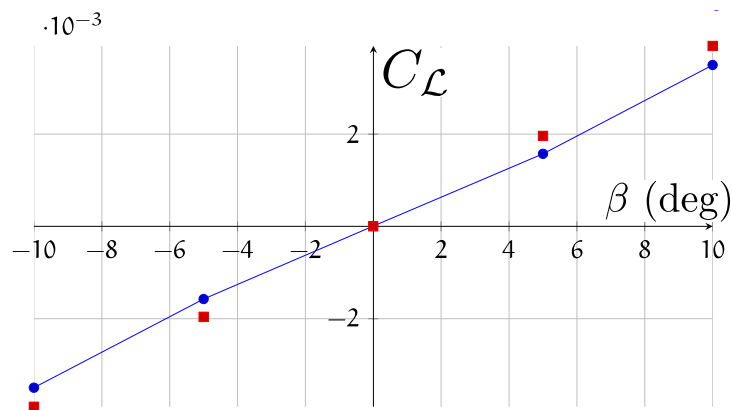
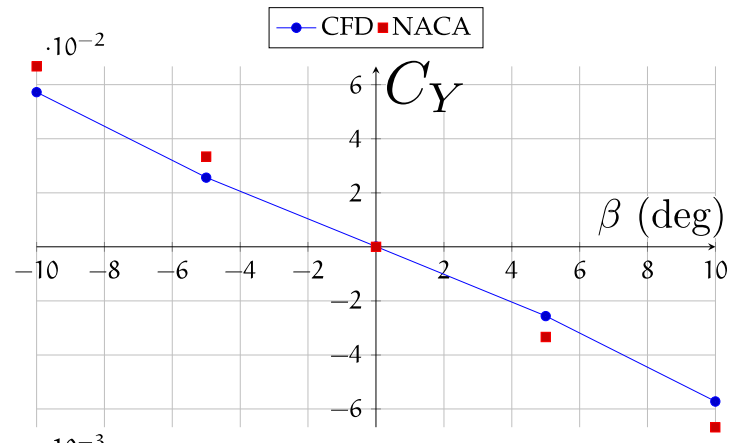

Directional test case

$$\alpha = 0^\circ \quad \beta = -10^\circ \text{ to } 10^\circ$$

$$Re = 710\,000$$

no. of cells $\approx 4\,000\,000$

Development of a new approach

Based on the aerodynamic interference effects highlighted by semi-empirical methodologies, for a typical configuration, the same effects have been investigated through a parametric CFD analysis.

Analysis of:

- Isolated vertical tail (effect of the VT aspect ratio and sweep angle)
- VT-body interference (effect of VT/body relative size)
- Wing sidewash effects (difference between high and low wing position)
- Horizontal tail effects (tailplane position, i.e. body-mounted vs. T-tail, and size)
- Separate effects estimation for control derivative



Many configurations have been investigated with a modular model, to provide a new approach to preliminary tailplane design.

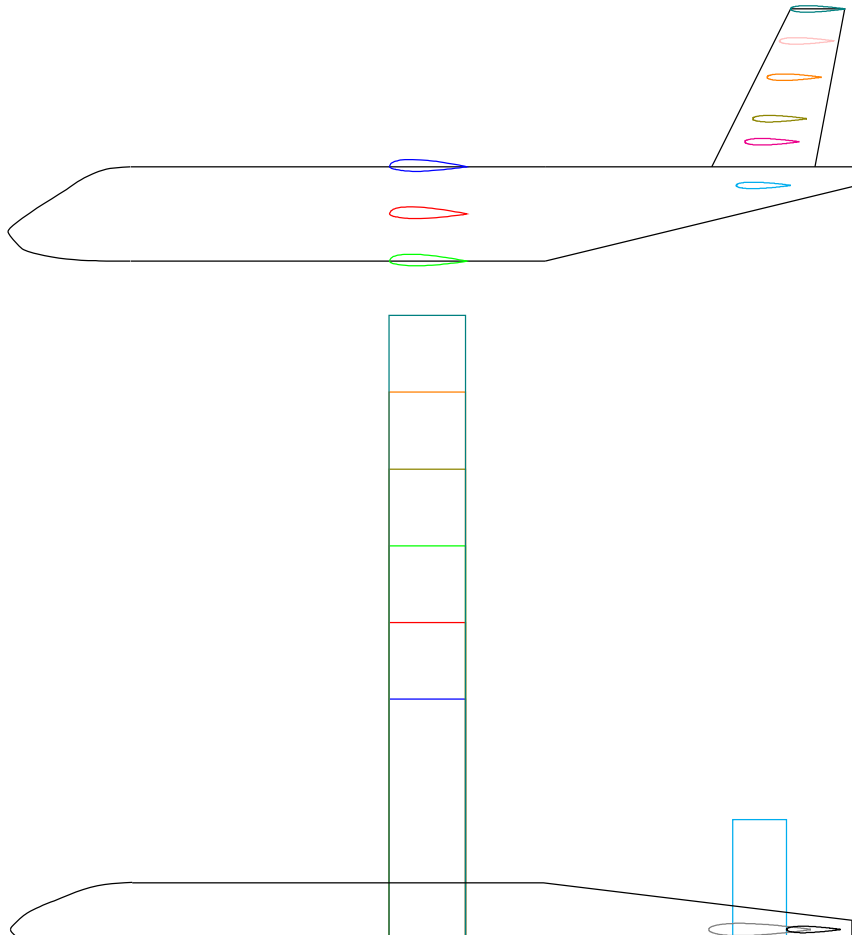

Table 8
Fuselage parameters.

	l_f/d_f	l_n/l_f	l_c/l_f	x_{wLE}/l_f
ATR-72	10.3	1.3	3.2	0.41
NGTP-5	9	1.3	3.3	0.47
CFD model	9	1.3	3.3	0.45

Table 9
Vertical tailplane parameters.

	A_v	λ_v	Δ_{vLE}	Δ_{vTE}	S_v/S	x_{vLE}/l_f	V_v
ATR-72	1.56	0.61	32°	17°	0.20	0.83	0.098
NGTP-5	1.43	0.63	29°	15°	0.24	0.85	0.110
CFD model	Variable	Variable	30°	15°	Variable	Variable	Variable

Table 10
Horizontal tailplane parameters.

	A_h	λ_h	Δ_{hLE}	Δ_{hTE}	S_h/S	x_{hLE}/l_f	V_h
ATR-72	4.1	n.a.	n.a.	n.a.	0.18	n.a.	0.19
NGTP-5	4.1	n.a.	n.a.	n.a.	0.25	n.a.	0.19
CFD model	4.1	0	0°	0°	Variable	Variable	Variable

Vertical tail planform effects on lift curve slope

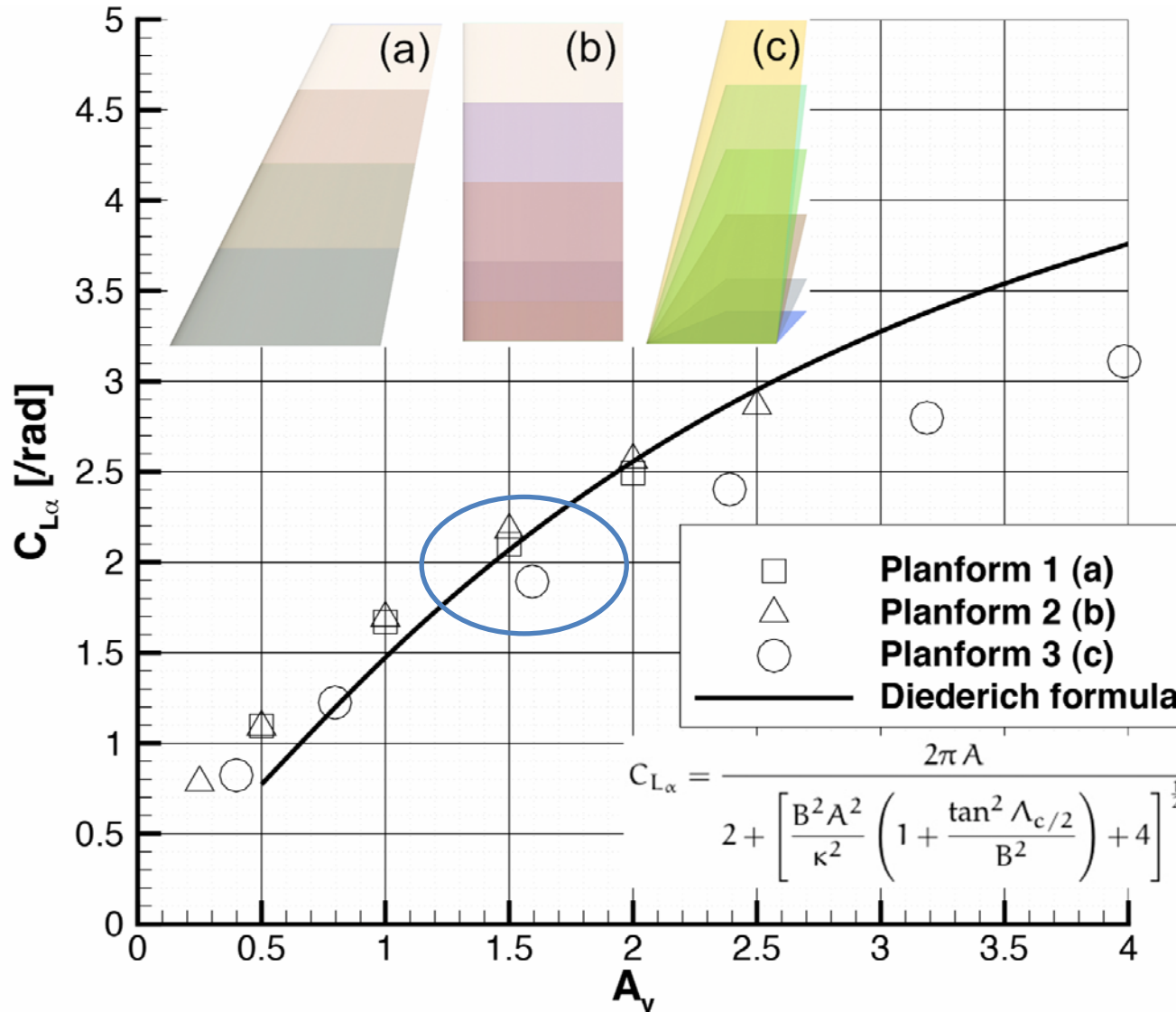

Typical values

$A_v = 1.5$

$\Lambda_v = 30^\circ$

$dC_{L\alpha} / dA_v \approx 1$

$$C_{L\alpha} = \frac{2\pi A}{2 + \left[\frac{B^2 A^2}{\kappa^2} \left(1 + \frac{\tan^2 \Lambda_{c/2}}{B^2} \right) + 4 \right]^{1/2}}$$

Configurations involved in the fuselage-tail investigation

The effect of the fuselage is measured by the ratio between the vertical tail sideforce coefficients of the body-vertical configurations and those of the same vertical tail planforms previously analysed.

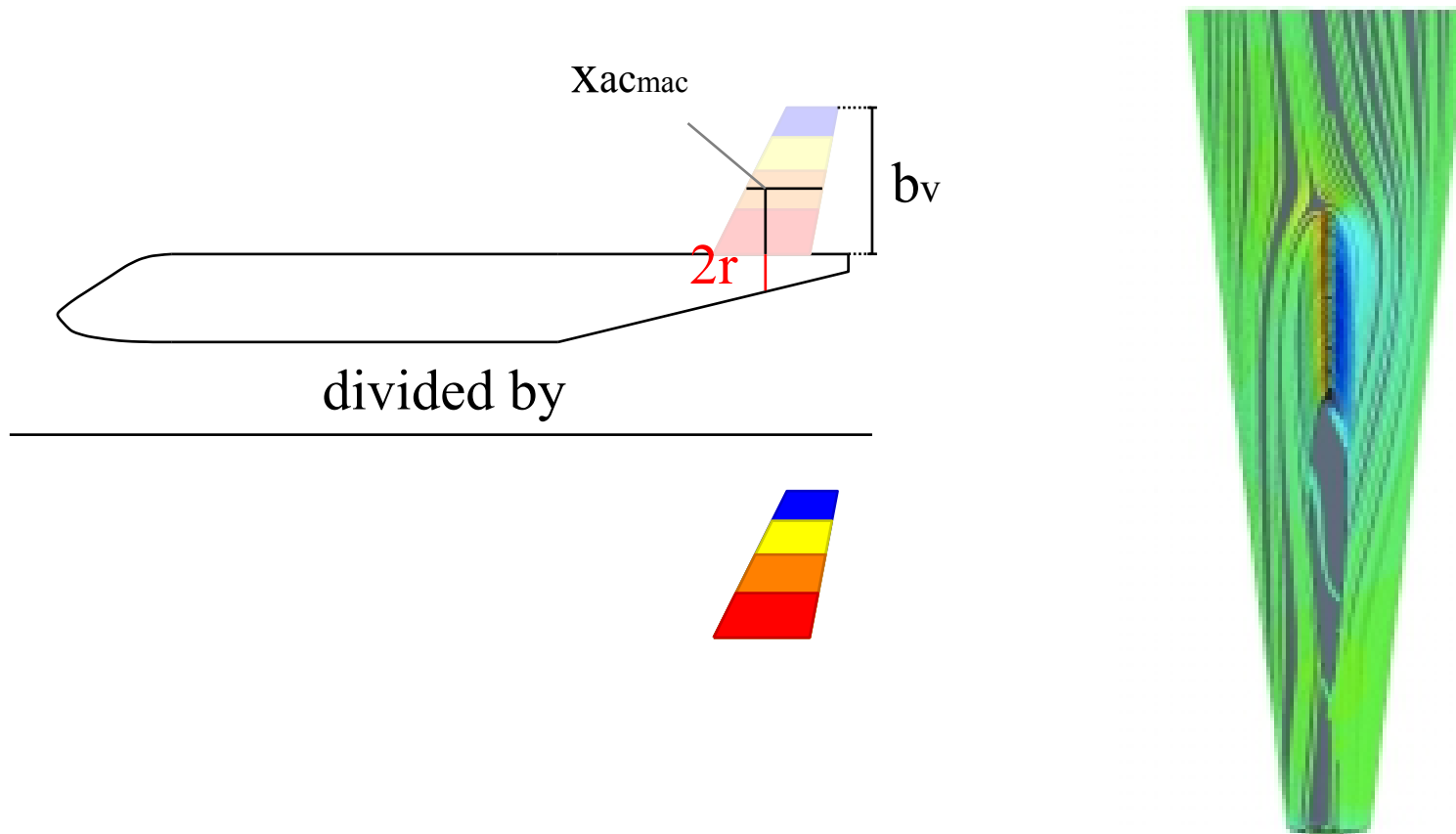

Fuselage effect K_F

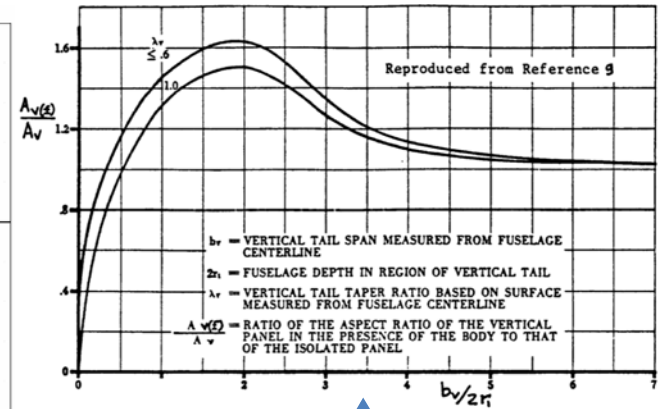
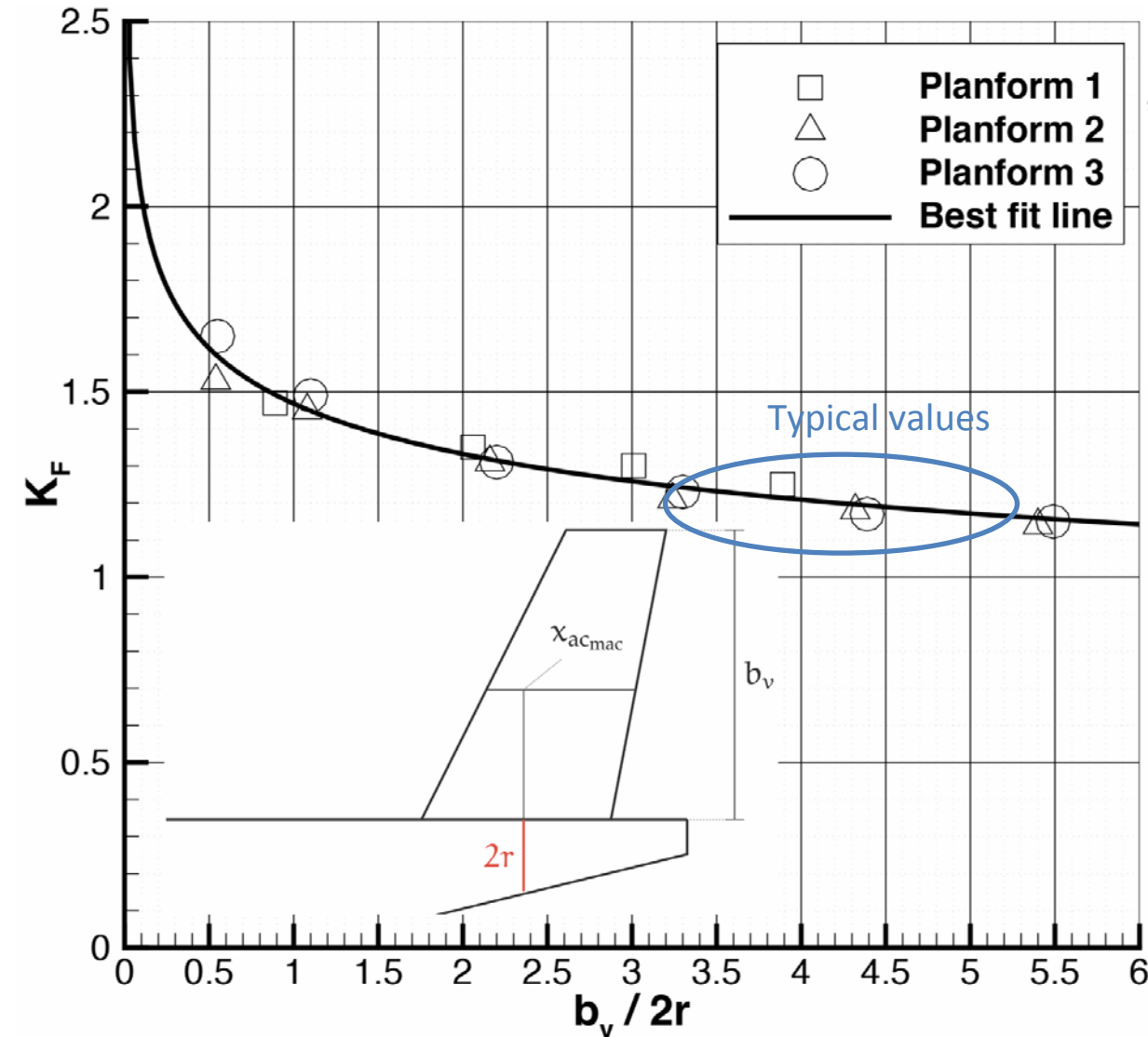

↑
USAF DATCOM

Configurations involved in the wing-body-tail investigation

Straight wings of different aspect ratio (6 to 16) in three fuselage positions (high, mid and low) have been considered. Two vertical tailplane aspect ratio (1 and 2) are considered.

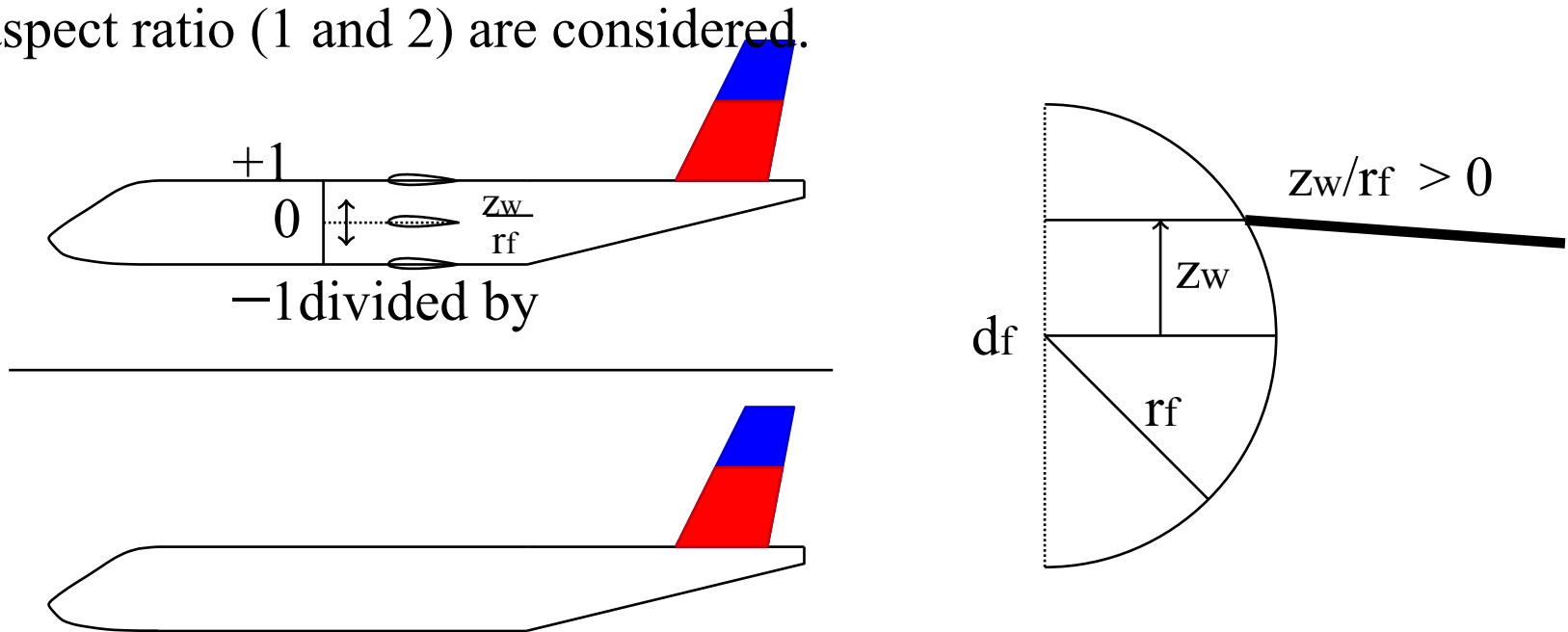

Wing effect K_w

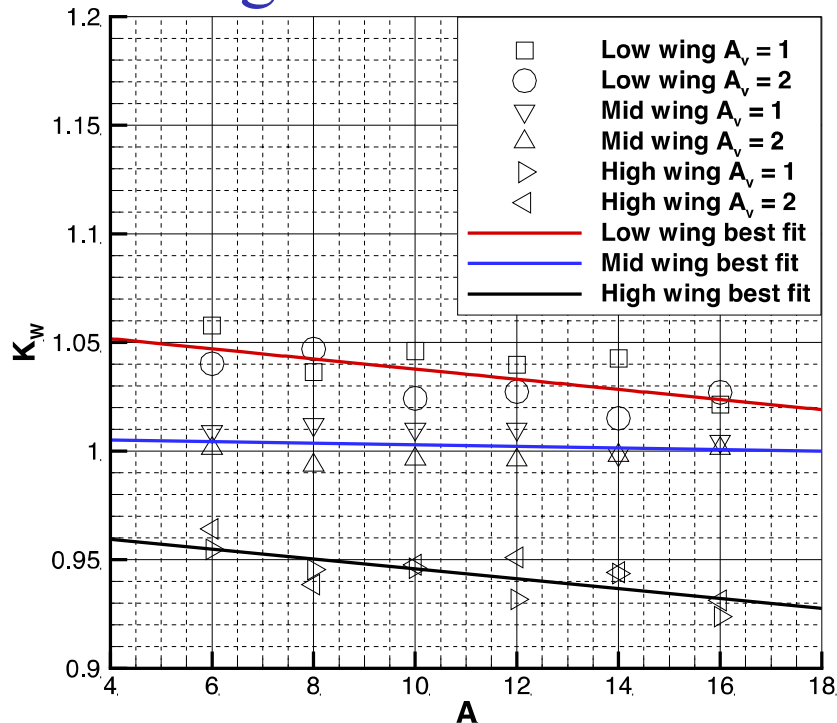

Primary effect (wing position)

Influence on angle of sideslip and dynamic pressure at VT root

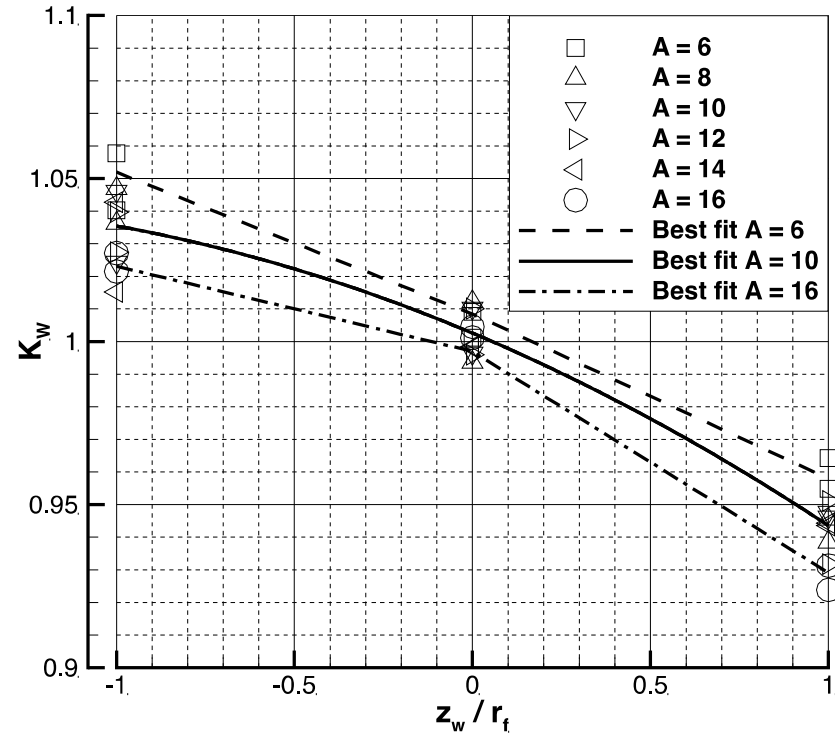
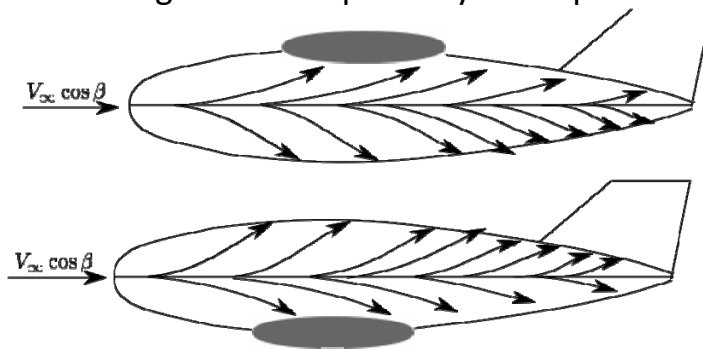

Secondary effect (wing AR)

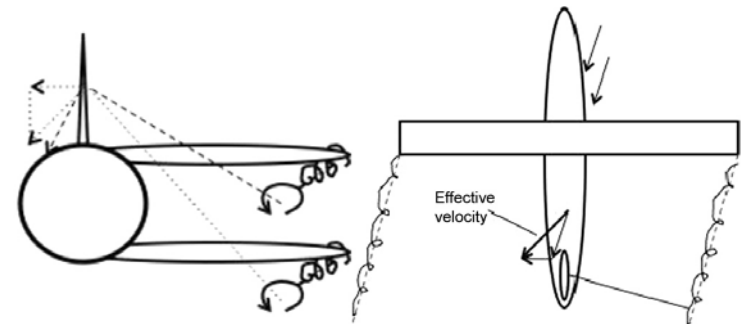

Wing-body sidewash

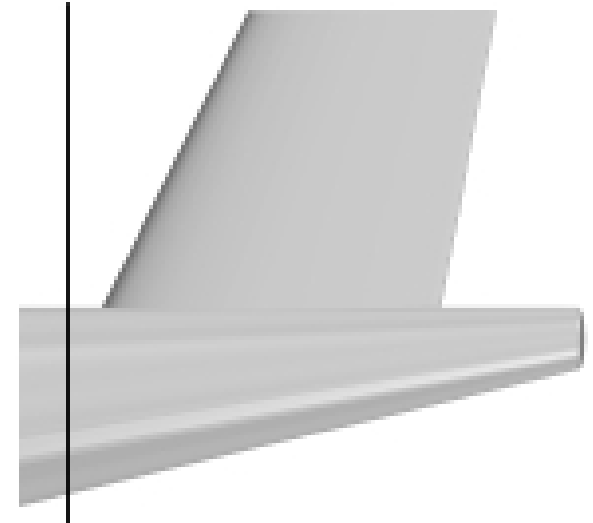
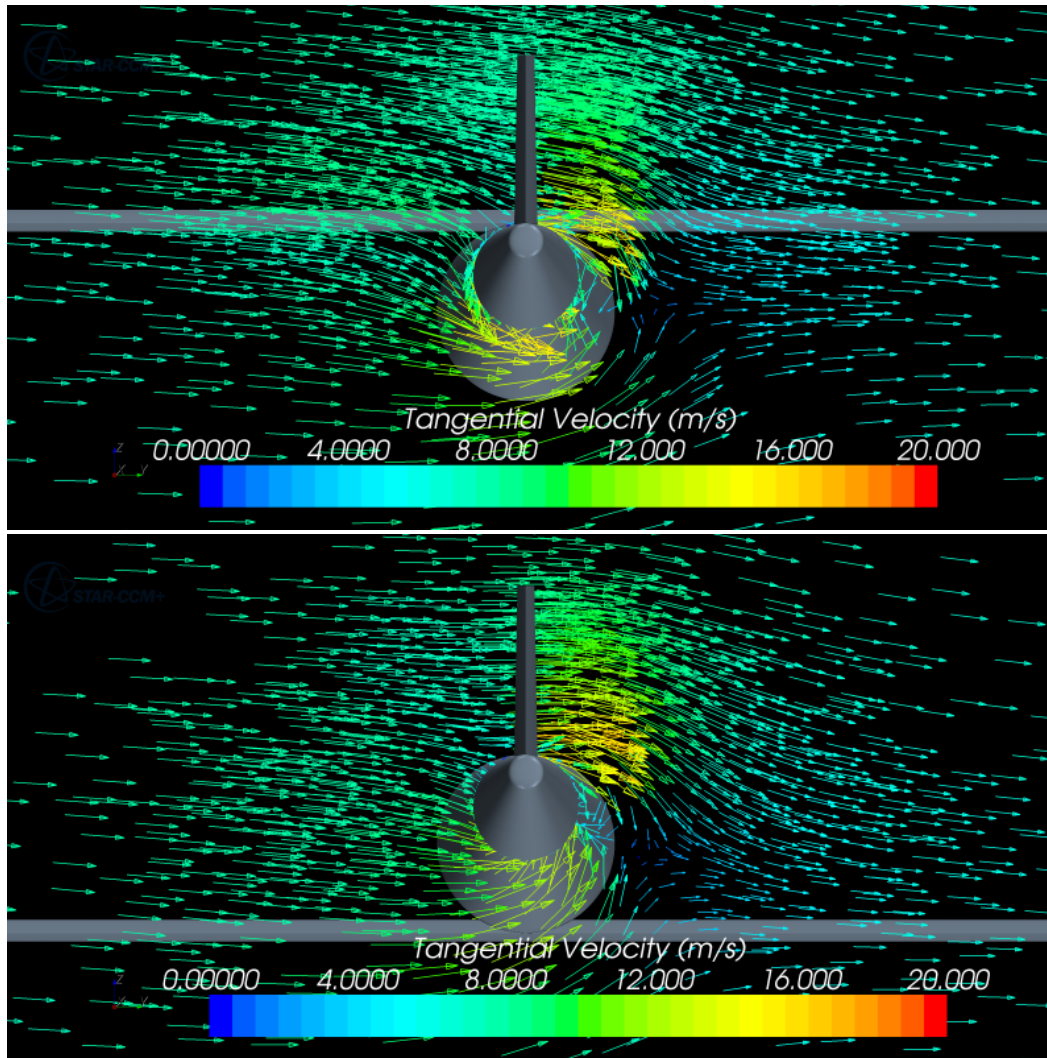

$$A = 10$$

$$A_v = 1$$

$$\beta = 5^\circ$$

Cross-wind direction \rightarrow

Horizontal tailplane effect

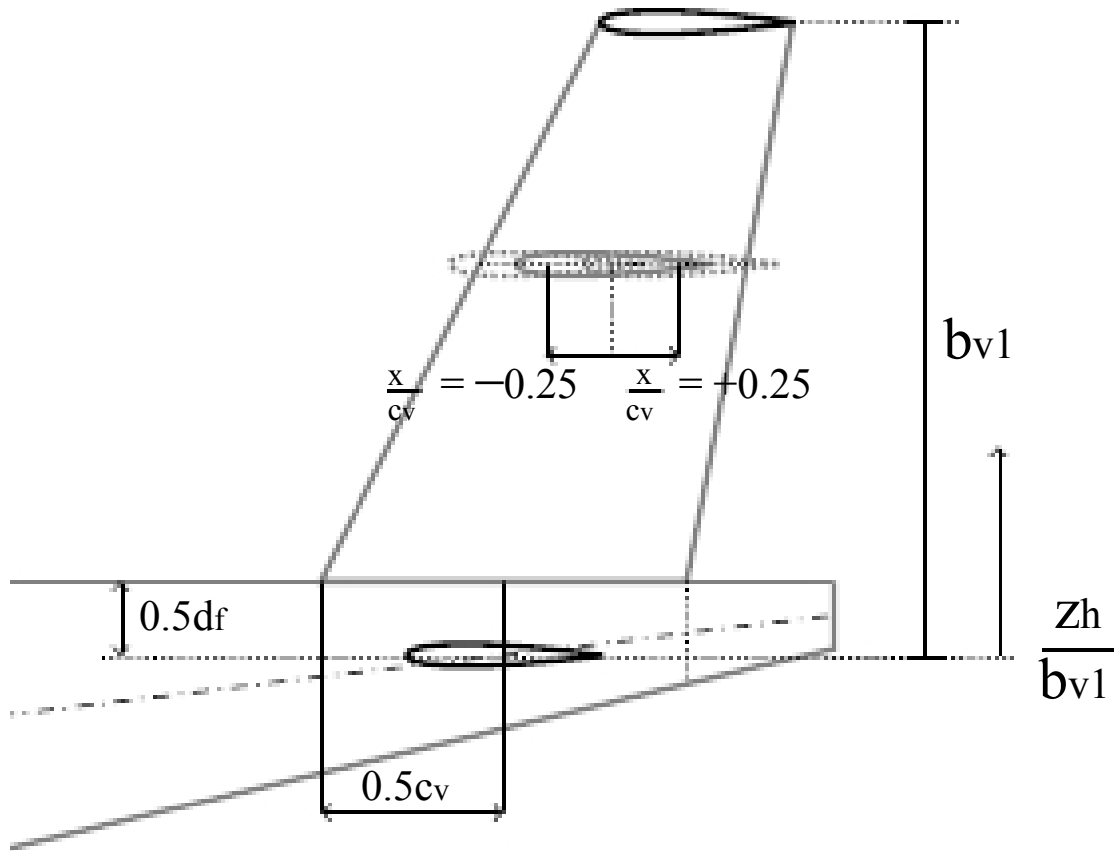

Configurations analysed

- 1 straight horizontal tail
- 6 spanwise positions
- 3 chordwise positions
- 3 vertical tail's aspect ratios

Wing position (high/low) is **not** important (verified)

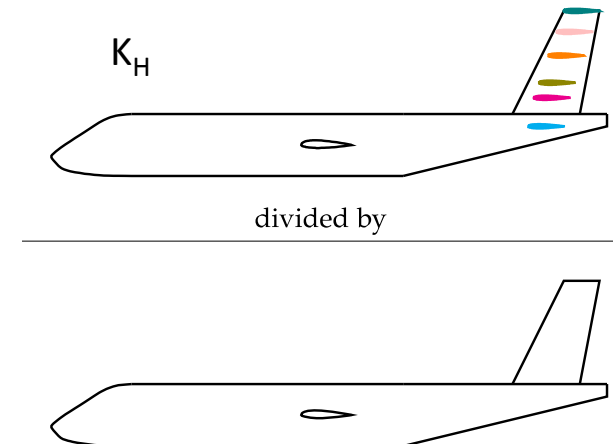

Horizontal tailplane effect K_H

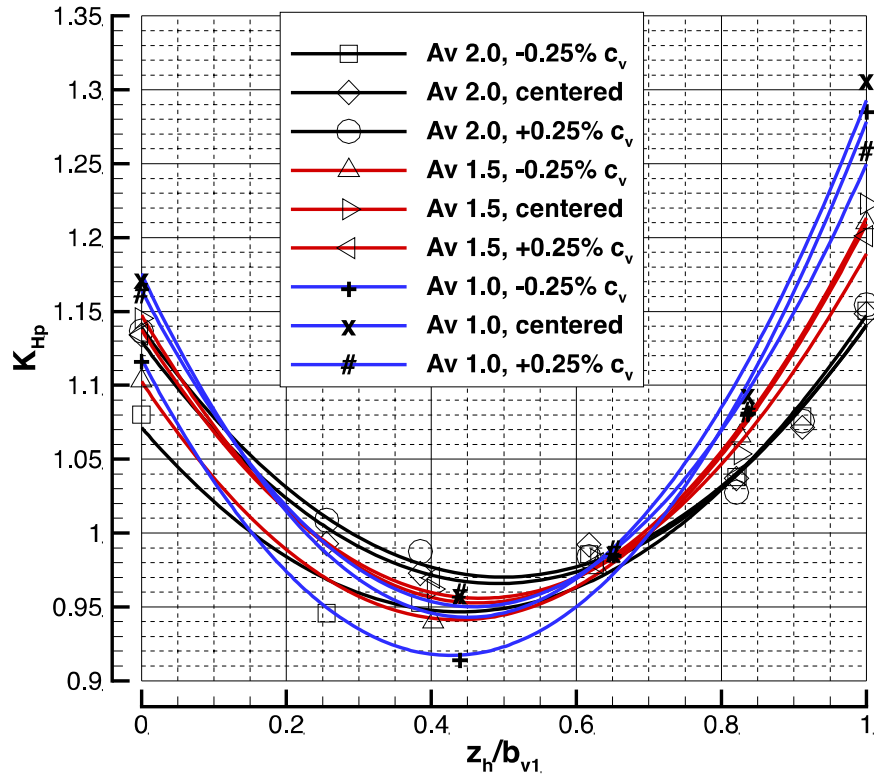

Position effect

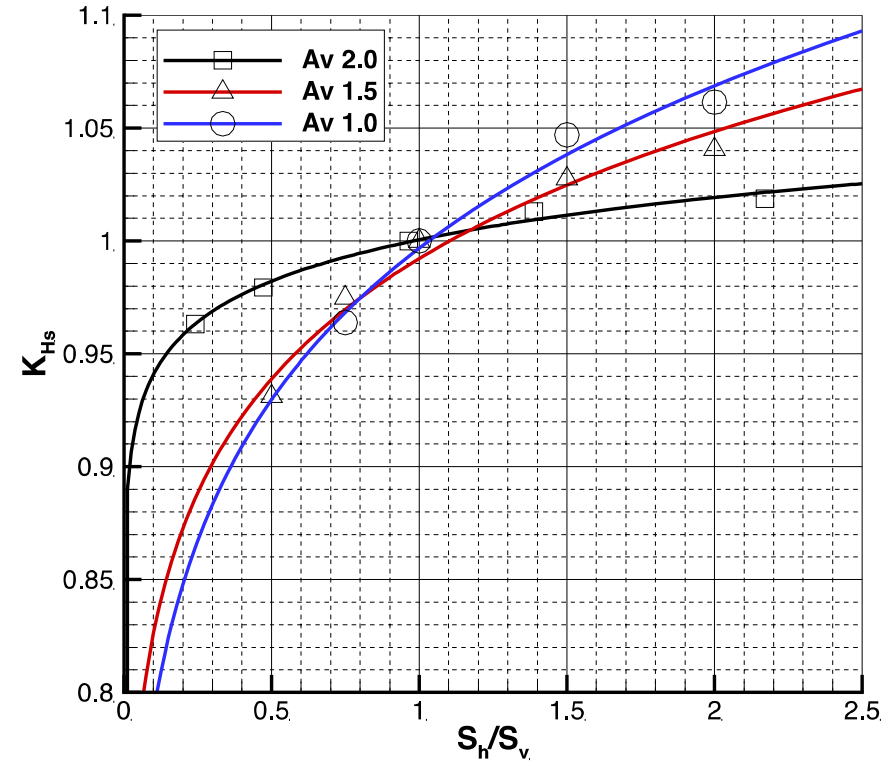

Size effect

$$K_H = 1 + K_{Hs} (K_{Hp} - 1)$$

T-tail configuration

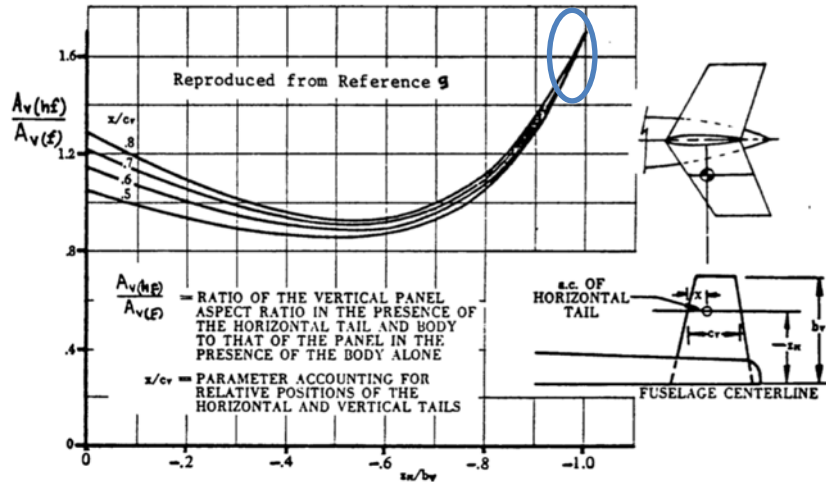

A_v	$C_{Y_v}(BVH)$	$C_{Y_v}(BV)$	ratio
1.0	0.0253	0.0194	1.30
1.5	0.0394	0.0322	1.22
2.0	0.0521	0.0451	1.15

In this approach the increase of VT effectiveness for T-tail configuration is much lower than USAF DATCOM prediction.

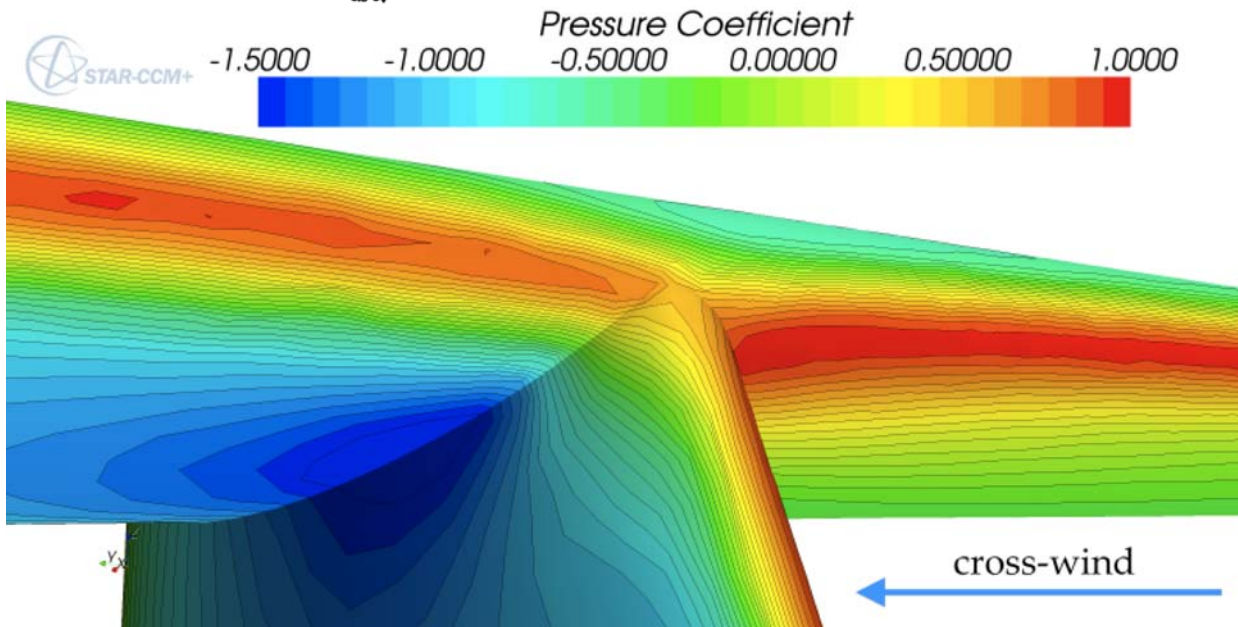

Directional control derivative

$$C_{Y_v} = C_{Y_{\beta v}} \beta + C_{Y_{\delta r}} \delta_r$$

$$C_{n_{\delta r}} = -C_{Y_{\delta r}} (I_v \cos \alpha + z_v \sin \alpha) / b$$

$$C_{Y_{\beta}} = -k_v C_{L_{\alpha v}} \left(1 + \frac{d\sigma}{d\beta} \right) \eta_v \frac{S_v}{S}$$

$$C_{Y_{\delta r}} = C_{L_{\alpha v}} (A_{\text{veff}}) \tau K_{\eta} \frac{S_v}{S}$$

USAF DATCOM

The aerodynamic interference effects due to fuselage and horizontal tail are considered to be the same for both derivatives (stability and control).

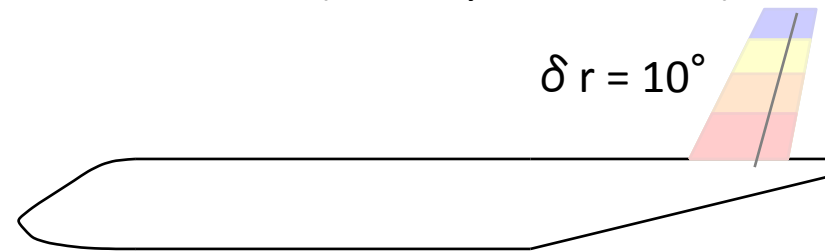

divided by

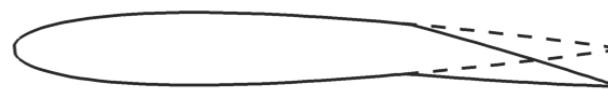

$\delta_r = 10^\circ$

Our approach:

$$C_{Y_{\beta v}} = f(K_F, K_W, K_H)$$

$$C_{Y_{\delta r}} = f(K_{\delta r})$$

Investigation on rudder deflection's effects

A_v	$b_v/2r$	$C_{YV}(V)$	$C_{YV}(BV)$	BV/V
1.0	2.06	0.0303	0.0348	1.15
1.5	3.01	0.0505	0.0563	1.12
2.0	3.89	0.0682	0.0751	1.10

$\beta = 0^\circ$
 $\delta r = 10^\circ$

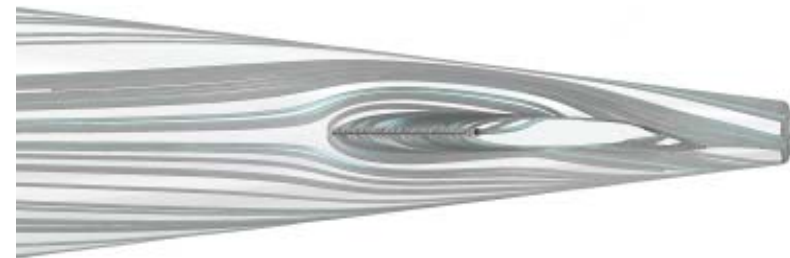
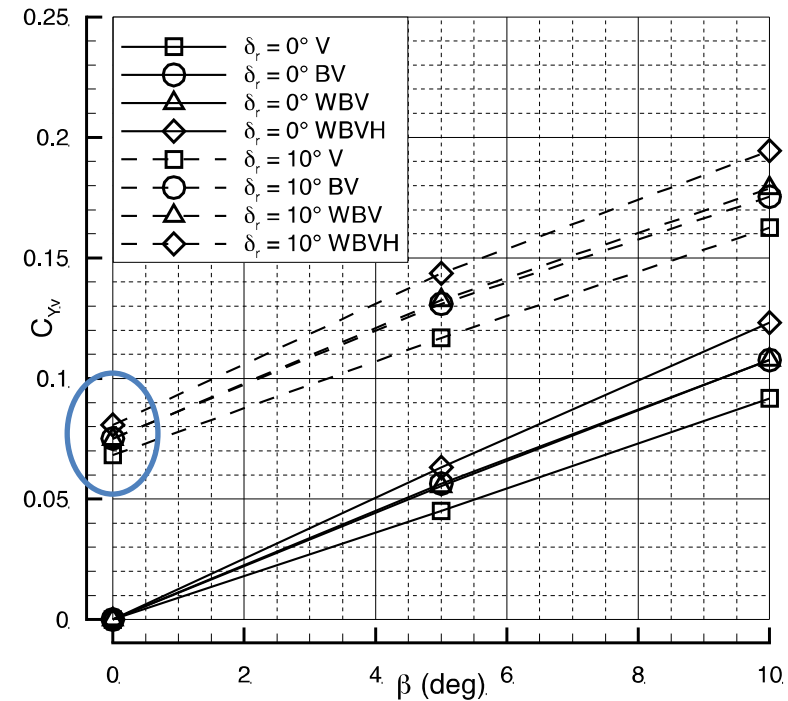
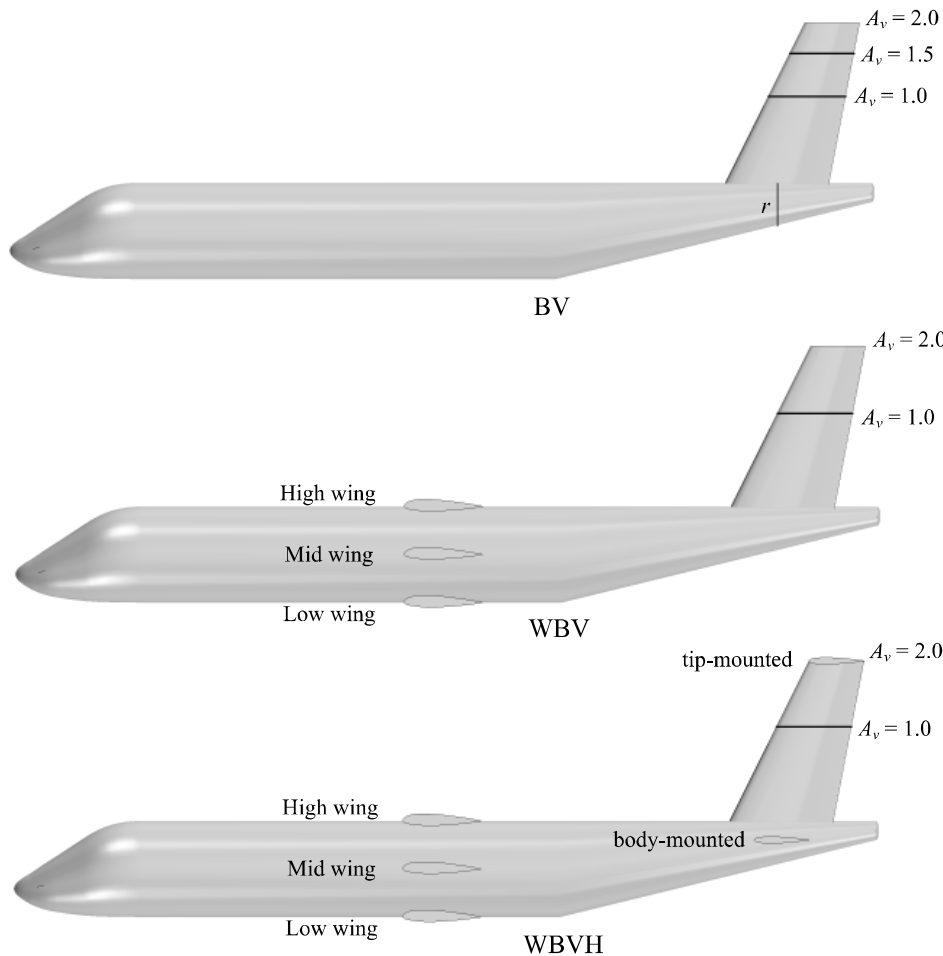

Vertical Tail Stability and Control

Evaluation of the vertical tail contribution to aircraft directional stability and control. Developed with more than 200 CFD simulations. Valid in subsonic incompressible flow at low angles of incidence and sideslip.

$$C_{Y_v} = C_{Y_{\beta_v}} \beta + C_{Y_{\delta_r}} \delta_r$$

where

$C_{Y_{\beta_v}}$ directional stability derivative,
 β sideslip angle,
 $C_{Y_{\delta_r}}$ directional control derivative,
 δ_r rudder's deflection angle.

Directional stability

The interference effects previously evaluated are now combined.

$$C_{Y_{\beta_v}} = K_F K_W K_H C_{L_{\alpha_v}} \frac{S_v}{S}$$

where

K_F	fuselage effect,
K_W	wing effect,
$K_H = 1 + K_{H_s} (K_{H_p} - 1)$	horizontal tailplane effect,
K_{H_p}	horizontal tailplane position effect,
K_{H_s}	horizontal tailplane size effect,
$C_{L_{\alpha_v}} = f(A_v, \Lambda_v, M)$	Helmholtz-Diederich formula.

The new approach for directional control derivative

$$C_{Y_{\delta_r}} = K_{\delta_r} C_{L_{\alpha_v}} \alpha_{\delta} \frac{S_v}{S}$$

3D rudder effectiveness
(estimated on the isolated vertical tail)

$$K_{\delta_r} = \left[1 + \frac{K_F - 1}{2.2} \right] \cdot \begin{cases} 1.07, & \text{if horizontal tail is body-mounted,} \\ 1.33 - 0.9A_v & \text{for T-tail configurations.} \end{cases}$$

Body effect is the reduced to
the half of that one previously
investigated in sideslip

Example of application

Tecnam P2012

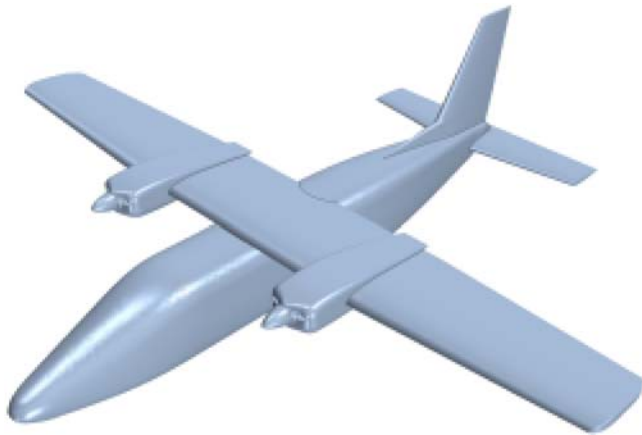

Δ from CFD

New meth	5.0 %
USAF	34.0 %
ESDU	8.8 %

$C_{L\alpha_v}$		2.160 rad ⁻¹
K_F		1.260
K_W		0.953
K_{Hp}		1.139
K_{Hs}		1.022
K_H		1.142
$K_F K_W K_H$		1.371
$C_{Y_{\beta_v}}$	New meth	0.358 rad ⁻¹
$C_{Y_{\beta_v}}$	USAF	0.249 rad ⁻¹
$C_{Y_{\beta_v}}$	ESDU	0.410 rad ⁻¹
$C_{Y_{\beta_v}}$	CFD	0.377 rad ⁻¹

Conclusion

A new procedure to evaluate the aerodynamic interference of airplane's components on the vertical tailplane has been proposed. It has been developed by solving Navier-Stokes equations in a fully turbulent subsonic flow regime on more than 200 regional turboprop aircraft configurations, with the aim to bring CFD into aircraft preliminary design.

Features of the new procedure:

- Based on actual turboprop aircraft geometries
- Low data scatter among configurations
- Simplicity of the approach

Drawbacks:

- Extendable to commuters or jet airplanes?
- No engine, dihedral, wing sweep, flaps or propeller effects considered
- **To do: wind tunnel tests**