

A Late Jurassic salamander (Amphibia: Caudata) from the Morrison Formation of North America

S. E. EVANS^{FLS}^{1*}, C. LALLY¹, D. C. CHURE², A. ELDER² and J. A. MAISANO³

¹*Department of Anatomy and Developmental Biology, University College London, Gower Street, London, WC1E 6BT, UK*

²*United States Parks Service, Dinosaur National Monument, Jensen, UT 84035, USA*

³*Department of Geological Sciences, University of Texas at Austin, Austin, TX 78712–1100, USA*

Received February 2004; accepted for publication November 2004

Despite some remarkable recent discoveries, the Mesozoic fossil record of salamanders remains limited, particularly for the Jurassic. Here we describe the first articulated salamander skeleton from the Jurassic of Euramerica, recovered from Upper Jurassic deposits of the Morrison Formation, Dinosaur National Monument, USA. The specimen was studied using both conventional methods and high-resolution computed tomography. It shows a combination of primitive and derived character states that distinguish it from all known Mesozoic salamanders and which permit the erection of a new genus and species, *Iridotriton hechti*. The derived states (including the presence of spinal nerve foramina in the tail) suggest a position on the stem of the Salamandroidea. Together with microvertebrate material from Britain, Portugal, and North America, this specimen confirms the presence of both stem- and crown-group salamanders in Euramerica from the Middle Jurassic (Bathonian) onwards, paralleling their evolution in Central and eastern Asia. This, in turn, provides qualified support for the current vicariance model of salamander evolution whereby basal caudates on an undivided Laurasian plate became separated into two populations by the incursion of the Turgai Sea in the Middle Jurassic, yielding Cryptobranchoidea in Asia and Salamandroidea in Euramerica. © 2005 The Linnean Society of London, *Zoological Journal of the Linnean Society*, 2005, 143, 599–616.

ADDITIONAL KEYWORDS: biogeography – computed tomography – evolution – Lissamphibia – phylogeny – skeleton – Urodela.

INTRODUCTION

Salamanders and their immediate relatives (Caudata) are traditionally grouped with other living amphibians (frogs, caecilians) in the Lissamphibia (e.g. Milner, 1988; McGowan & Evans, 1995; Ruta, Coates & Quicke, 2003) although the monophyly of the latter clade has been questioned (e.g. Carroll & Holmes, 1980; Laurin & Reisz, 1997). Patterns of relationship within and between component clades are also strongly debated, with morphology generally placing frogs and caudates as sister taxa (e.g. Milner, 1988; Laurin & Reisz, 1997; Ruta *et al.*, 2003; but see Bolt, 1991), whereas molecular analysis supports a relationship between caudates and caecilians (e.g. Larson, 1991; Hedges & Maxson, 1993; Hay *et al.*, 1995; Feller & Hedges, 1998). Clearly, more information is needed

about the early fossil record of each clade. Stem-frogs are known from the Early Triassic of Madagascar (e.g. Rage & Roček, 1989) and Poland (Evans & Borsuk-Bialynicka, 1998), but caecilians are not recorded before the Early Jurassic of North America (Jenkins & Walsh, 1993), and caudates are first described from the Middle Jurassic of Central Asia (Nessov, 1981, 1988; Nessov *et al.*, 1996), Britain (Evans, Milner & Mussett, 1988; Evans, 1992; Evans & Milner, 1994; Evans & Waldman, 1996), and, putatively, China (Gao & Shubin, 2003; but see Discussion). *Triassurus* (Ivachnenko, 1978) is a possible salamander from the Upper Triassic of Uzbekistan, but the specimen is apparently larval and of uncertain systematic position (Estes, 1981).

Caudata are essentially a Laurasian group with limited extensions into Gondwana. Milner (1983) argued that a pan-Laurasian ancestral group of stem-caudates became subdivided when an incursion of the

*Corresponding author. E-mail: ucgasue@ucl.ac.uk

Turgai Sea separated Asia and Euramerica in the Middle Jurassic. Each population then gave rise to one of the two major caudate clades, Cryptobranchioidea (in Asia) and Salamandroidea (in Euramerica).

To date, the first attributable salamandroids are of Early Cretaceous age: *Apricosiren* (Berriasian, England; Evans & McGowan 2002); indet. taxa (Berriasian, England; Ensom, Evans & Milner, 1991; Evans & McGowan, 2002); *Hylaebatrachus* (Hauterivian, Belgium; Dollo 1884); indet. taxa (Hauterivian-Valanginian, England; Milner & Evans 1998); *Valdotriton* (Barremian, Spain; Evans & Milner, 1996); *Galverpeton* (Barremian-Aptian, Spain; Estes & Sanchíz, 1982), an undescribed perennibranchiate form (Barremian, Spain; Evans *et al.*, 1995), and *Prosiren* (Aptian/Albian, USA; Estes, 1969. Note, however, that Estes incorrectly combined the real salamander vertebrae of *Prosiren* with the jaws of the noncaudate *Albanerpeton*; Fox & Naylor, 1982). Of these Euramerican taxa, the most completely known is *Valdotriton*, a stem-salamandroid (Evans & Milner, 1996). Fragmentary remains from the Middle Jurassic of Britain ('Salamander B'; Evans & Milner, 1994) and the Late Jurassic of North America (Evans & Milner, 1993) have suggested that derived salamanders were present in Euramerica before the Cretaceous, but discussion has been constrained by the limitations of the material (isolated vertebrae, pieces of jaw).

In recent years, the Rainbow Park microsite at Dinosaur National Monument, Utah, has yielded two blocks with articulated salamander skeletons, both from the Upper Jurassic Brushy Basin Member of the Morrison Formation. The two blocks carry specimens representing two distinct taxa. One taxon (represented by several entwined partial skeletons) is currently being studied by Bruce Naylor and James Gardner at the Royal Tyrrell Museum, Drumheller, Canada. The second taxon is described here.

Institutional acronym used in this paper: DINO, US National Parks Service, Dinosaur National Monument.

GEOLOGY AND MATERIALS

The Brushy Basin Member of the Morrison Formation at Dinosaur National Park, Utah, is best known for its macrovertebrate (dinosaur) remains but has begun to yield a valuable assemblage of small vertebrates including frogs (Henrici, 1998), lizards (Evans & Chure, 1998a, b), sphenodontians (Fraser & Wu, 1998), mammals (Engelmann & Callison, 1998), and salamanders. Fortunately the Morrison Formation in this region contains volcanic ash layers that have yielded isotopic ages ($^{40}\text{Ar}/^{39}\text{Ar}$). These consistently place the Brushy Basin Member between 150.3 ± 0.3 Myr (base) and 148.1 ± 0.5 Myr (top) (Kowallis *et al.*, 1998). It is thus Kimmeridgian or early Titho-

nian in age (according to the timescale of Gradstein *et al.*, 1995).

Although fragmentary salamander material (a femur, *Comonecturoides marshi* Hecht & Estes, 1960; partial vertebrae and other elements; Estes, 1981; Evans & Milner, 1993) has already been described from the Morrison Formation (Quarry 9, Como Bluff), the specimens are difficult to classify. The new specimens from Dinosaur National Monument currently represent the earliest known articulated material from Euramerica. The specimen described here, DINO 16453 (Fig. 1), is in two parts: 16453a (Fig. 2) carries the bulk of the skeleton, preserved in dorsal view, whereas 16453b (Fig. 3) is a partial counterpart bearing vertebrae, girdle and hind limb elements in ventral view.

METHODOLOGY

The specimen was prepared mechanically as far as practicable, but cracks in the undersurface as well as the compression and superimposition of many bones (e.g. in the skull, forelimbs) preclude full exposure. To compensate, the main block (DINO 16453a) was scanned at the High-Resolution X-ray Computed Tomography Facility at The University of Texas (Austin), Geological Sciences, and then digitally reconstructed (Figs 4, 5, http://digimorph.org/specimens/Iridotriton_hechti). The resulting data set consists of 378 slices taken along the long axis of the specimen, each slice 62 μm thick, with an interslice spacing of 62 μm and an in-plane resolution of 38 μm per pixel. Visualizations were generated using VGStudioMax 1.1 (Volume Graphics, Heidelberg). This imaging technique has provided new information, particularly with respect to the limb skeleton, pectoral girdle, and the underside of the skull. However, not all details could be fully resolved because DINO 16453a consists of a small, delicate skeleton in a relatively large block of matrix that could not be further trimmed because of deep internal cracks (as revealed by the scan). The presence of the broad matrix rim surrounding the specimen limits the resolution of very small structures (e.g. delicate teeth) and of superimposed or adjacent bones where there is little or no matrix between them.

SYSTEMATIC PALAEOONTOLOGY

LISSAMPHIBIA HAECKEL, 1866

CAUDATA SCOPOLI, 1777

URODELA DUMÉRIL, 1806

NEOCAUDATA CANNATELLA & HILLIS, 1993

FAMILY INDET.

IRIDOTRITON GEN. NOV.

Generic diagnosis: as for *Iridotriton hechti*, the only species.

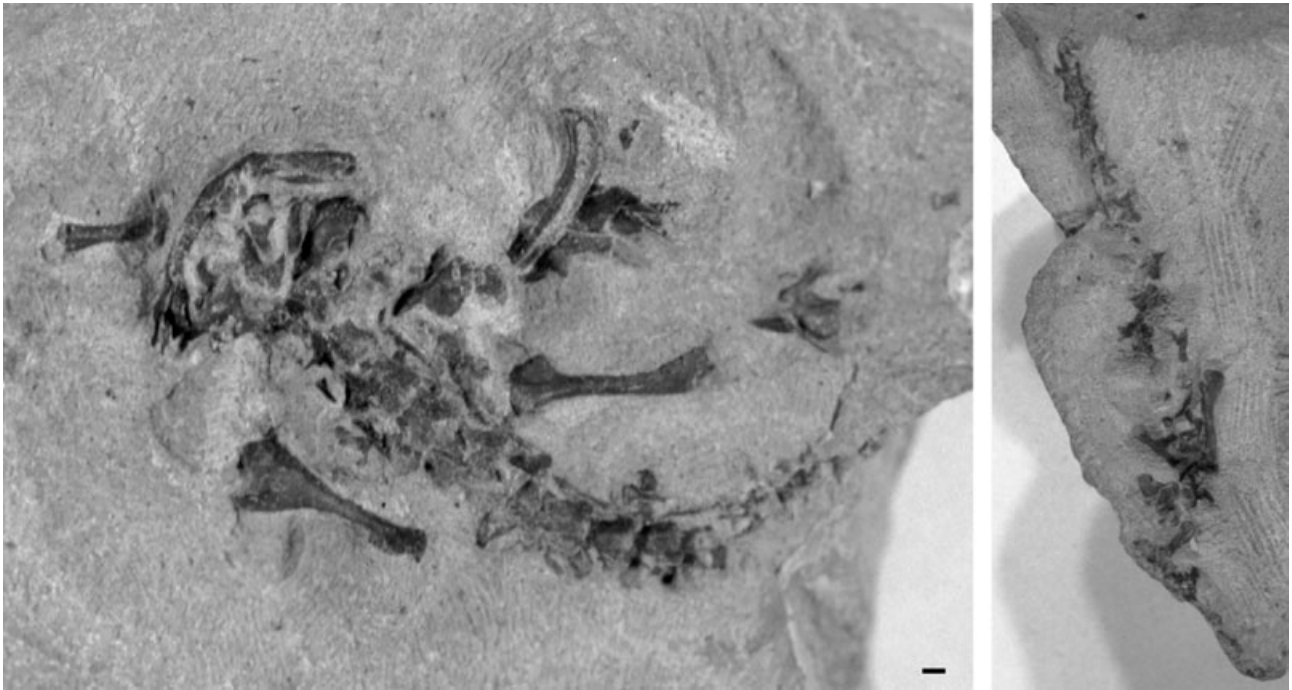

Figure 1. *Iridotriton hechti* gen. et sp. nov., holotype. Main figure (left) DINO 16453a; adjoining figure (right), DINO 16453b. Scale bar = 1 mm.

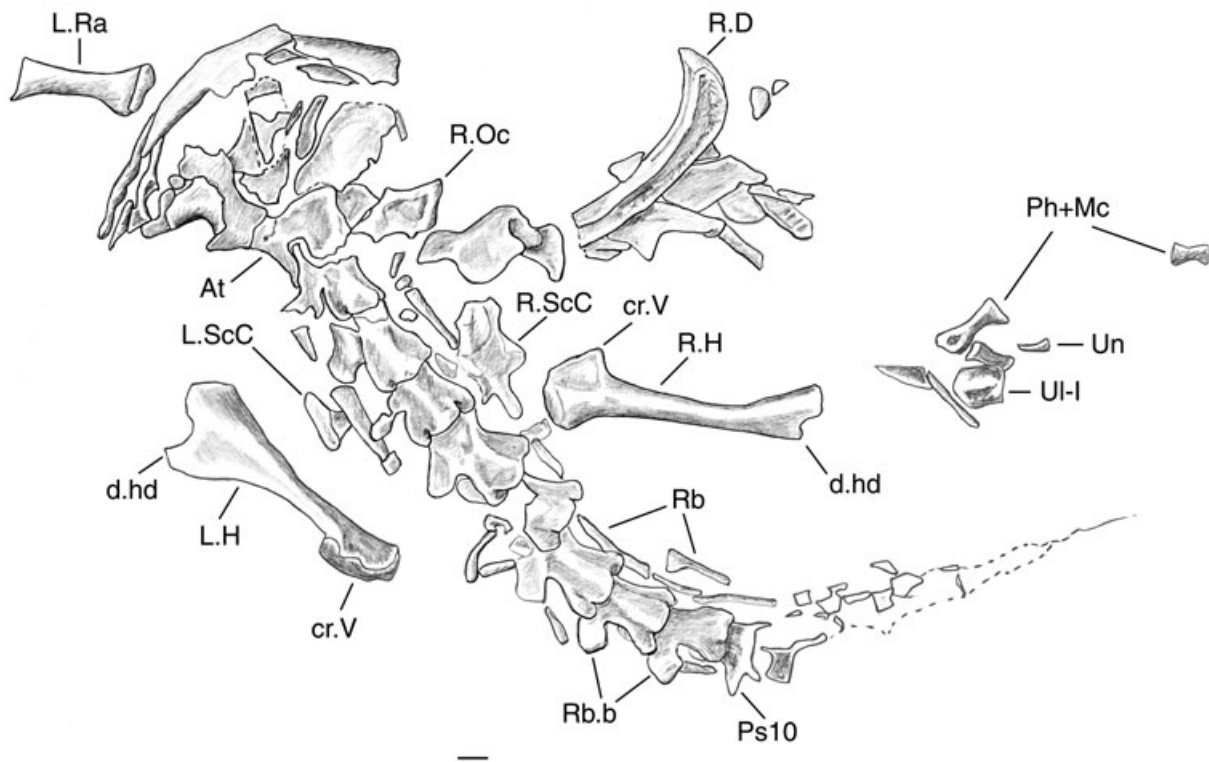

Figure 2. *Iridotriton hechti* gen. et sp. nov., DINO 16453a. Abbreviations: At, atlas; cr.V, crista ventralis humeri; d.hd, distal head of humerus; L.H, left humerus; L.Ra, left radius; L.ScC, left scapulocoracoid; Ph + Mc, phalanges and metacarpals; Ps, presacral vertebra; Rb, rib; Rb.b, rib-bearer; R.D, right dentary; R.H, right humerus; R.Oc, right otic capsule; R.ScC, right scapulocoracoid; UI-I, fused ulnare and intermedium; Un, unguial phalanx. Scale bar = 1 mm.

Type species: Iridotriton hechti gen. et sp. nov.

Derivation of generic name: from the Greek *Iris*, meaning rainbow, an allusion to the Rainbow Park microsite, and *Triton*, a newt.

IRIDOTRITON HECHTI SP. NOV.

Derivation of specific name: in honour of the late Max Hecht, one of the first authors to describe salamander material from the Morrison Formation.

Holotype: DINO 16453a, b, parts of a single skeleton missing only small skull bones, digits and the distal tail.

Locality: Dinosaur National Monument, Rainbow Park microsite (Dinosaur National Monument no. 96), Utah, USA (detailed locality data is held in the records at the Monument).

Horizon: Brushy Basin Member of the Morrison Formation, Upper Jurassic (c. 150–148 Myr; Kowallis *et al.*, 1998; Kimmeridgian or early Tithonian).

Specific diagnosis: a small (snout–sacrum length c. 55 mm) fully metamorphosed salamander distinguished by the following combination of characters: thin unsculptured skull bones; a fully open Meckelian fossa in the dentary; premaxilla with wide, short alary process having angled lateral edge; prootic, opisthotic and exoccipital form a single unit, although sutural lines separate the opisthotic from the other bones; stapes free; parasphenoid without internal carotid foramina, narrower anteriorly than posteriorly; an estimated 16 postatlantal presacral vertebrae; simple ectochordal vertebral centra, with small anterior basapophyses but no ventromedian keel; atlas shorter than succeeding vertebrae; spinal nerve foramina in atlas and in tail vertebrae; co-ossified scapula and coracoid, with narrow, waisted scapula and large, heavily ossified coracoid plate perforated by supraco-racoid foramen; strongly built forelimbs (relatively massive humerus with deep crista ventralis humeri and expanded distal head); radius with expanded distal head; well-ossified tarsus and carpus including fusion of ulnare and intermedium; rib-bearers with conjoined heads throughout the column.

Remarks: *Iridotriton* differs from the stem-caudates *Karaurus*, *Kokartus* and *Marmorerpiton* in lacking any trace of sculpture on the skull bones, and in having spinal nerve foramina in both the atlas and caudal vertebrae. It resembles the Chinese salamanders *Chunerpeton* (Gao & Shubin, 2003), *Jeholotriton* (Wang, 2000a), *Laccotriton* (Gao & Shubin, 2001), *Liaoxitriton* (Dong & Wang, 1998; Wang, 2004) and *Sinerpeton* (Gao & Shubin, 2001) in having conjoined surfaces on the rib-bearers and retaining a separate

angular in the jaw, but differs from *Sinerpeton* and *Laccotriton* in lacking a separate coronoid, and from all five Chinese taxa in having a much more massive humerus. *Iridotriton* further differs from *Chunerpeton* in prefrontal shape (shorter and squarer in *Chunerpeton*), squamosal shape (waisted below dorsal head in *Chunerpeton*), and the ossification of the tarsals and carpals (unossified in *Chunerpeton*). It differs from the Cretaceous *Valdotriton* (Evans & Milner, 1996) in having a broad rather than spike-like alary process of the premaxilla, a dentary with an open rather than anteriorly closed Meckelian groove, and conjoined rather than double-headed rib-bearers; and differs from *Valdotriton*, *Prosiren*, and *Apricosiren* (S. E. Evans, pers. observ.) in lacking ventromedian keels on the presacral centra. The Cretaceous *Hylaeobatrachus* is perennibranchiate (Estes, 1981) whereas *Iridotriton* is metamorphosed. The Cretaceous Spanish *Galverpeton* (Estes & Sanchíz, 1982) is based on a single trunk vertebra distinguished by the presence of a spinal nerve foramen and strong lateral crests, both of which are absent in the Morrison form. *Ramonellus* from the Early Cretaceous of Israel (Nevo, 1964; Nevo & Estes, 1969) differs in being very long-bodied (at least 34 presacrals) and in having a long retroarticular process on the lower jaw. Generic distinction for *Iridotriton* is therefore defensible.

Comonecturoides marshi Hecht & Estes, 1960, was described from the Morrison Formation at Quarry 9, Como Bluff, on the basis of a single isolated femur and, though clearly caudate, is a *nomen dubium* since it is restricted to an indeterminate type (Evans & Milner, 1993). The holotype femur is slightly smaller than that of *Iridotriton*, has a less projecting trochanter, and a less compressed proximal head.

Description

The specimen (DINO 16453a, b) is preserved in articulation and includes much of the skull, the complete presacral axial skeleton, the sacrum, a small set of postsacrals, and parts of the girdles and the limbs. The skull, forelimbs, and anterior presacral series (DINO 16453a) are preserved in dorsal view, but the posterior presacral region and left hind limb are on a small block (DINO 16453b) detached during collection and prepared in ventral view. The specimen is generally well preserved in three dimensions, with the vertebrae fully articulated, but there has been some disarticulation of the limbs and girdles and of parts from the right side of the skull roof and jaws. It is not possible to get an accurate measurement of the snout–sacrum length, but comparison of humeral and femoral lengths with those of similarly proportioned modern analogues suggests a snout–sacrum length of 50–60 mm, and a total length (with tail) of between 80

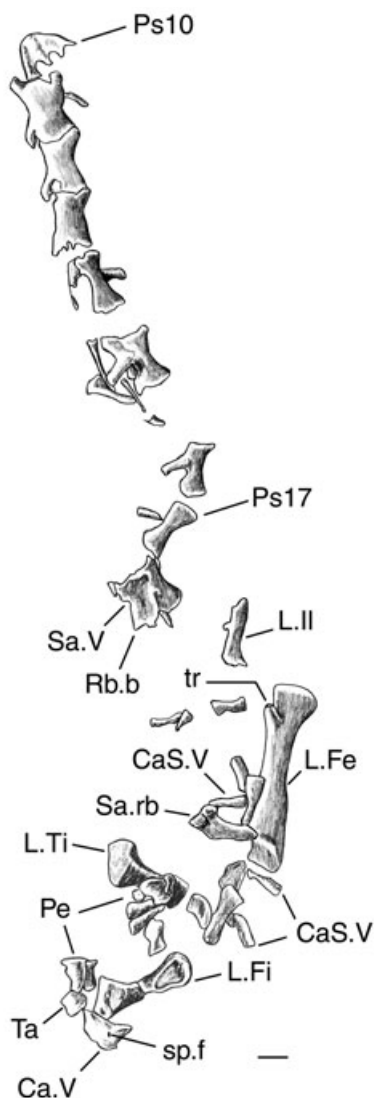

Figure 3. *Iridotriton hechti* gen. et sp. nov., DINO 16453b. Abbreviations: CaS.V, caudosacral vertebra; Ca.V, caudal vertebra; L.Fe, left femur; L.Fi, left fibula; L.II, left ilium; Pe, elements of pes; Ps, presacral vertebra; Rb.b, rib-bearer; Sa.rb, sacral rib; Sa.V, sacral vertebra; sp.f, spinal nerve foramen; Ta, tarsal; L.Ti, left tibia; tr, trochanter. Scale bar = 1 mm.

and 100 mm overall. Despite this small size, the specimen appears to represent a metamorphosed individual (dermal roofing bones ossified and in position; squamosal full size, all bones of lower jaw ossified, dorsal process of maxilla ossified, vomer fully formed, otic capsule complete and stapes ossified: Rose, 2003).

Figures 1–3 show the specimen as preserved on the blocks, but the description that follows also relies on the digital reconstructions from computed tomography (Figs 4, 5).

The skull

The posterior part of the skull aligns with the vertebral column, but the more anterior half, including the jaws, has rotated to the right (Fig. 6). Despite this, the bones of the left side are roughly *in situ* (but telescoped) whereas those of the right have been displaced out to the side of the specimen. A majority of the skull elements can be identified but some of the small bones (lacrimals and septomaxillae, if present) cannot be recognized.

Premaxilla: both bones are preserved, the left *in situ* and the other displaced and rotated to the right of the specimen. They show an elongated maxillary process that either abuts or underlaps the maxilla. The alary process (processus dorsalis) of the left premaxilla is damaged but the right is complete. It is short, broad, and asymmetric, with a strong lateral angle. A premaxillary tooth count is not possible.

Maxilla: the left bone is also *in situ* and essentially complete except for the medial edge of its dorsal (facial) process. The bone has an elongate premaxillary process, a short dorsal process, and a slender posterior process. The right bone is adjacent to the right premaxilla but has been rotated so that its lingual surface is exposed. The teeth are damaged and no tooth count is possible.

Nasal: a probable right nasal lies adjacent to the dorsal process of the right premaxilla. It appears to be divided into two parts by a deep cleft (though this could be an artefact of breakage). Division would imply paired nasal anlagen that are in contact posteriorly (as in the Cretaceous *Valdotriton*; Evans & Milner, 1996). There is a bone of similar size behind the left premaxilla, but the details are obscured.

Prefrontal: a single slender element lies adjacent to the dorsal process of the left maxilla. The identification of this bone as a prefrontal relies on its position to one side of the midline and its posteriorly tapering shape. It is closely similar to the same element in the extant *Cryptobranchus* and the hynobiid *Onychodactylus* (S. E. Evans, pers. observ.), and to the reconstructed shape of the Cretaceous *Valdotriton* (Evans & Milner, 1996). The bone is damaged in the midsection but the intervening impression suggests that this is a single bone and there is no trace of any groove or foramen for the lacrimal duct. No lacrimal has been recognized in *Iridotriton*, but given the telescoping of individual elements, and the various small unidentified elements within the skull mass, we cannot determine whether a lacrimal was present or absent.

Frontals: the left bone is represented by a thin plate deep to the left prefrontal and overlying the left parietal. It is long and relatively narrow, but shows no

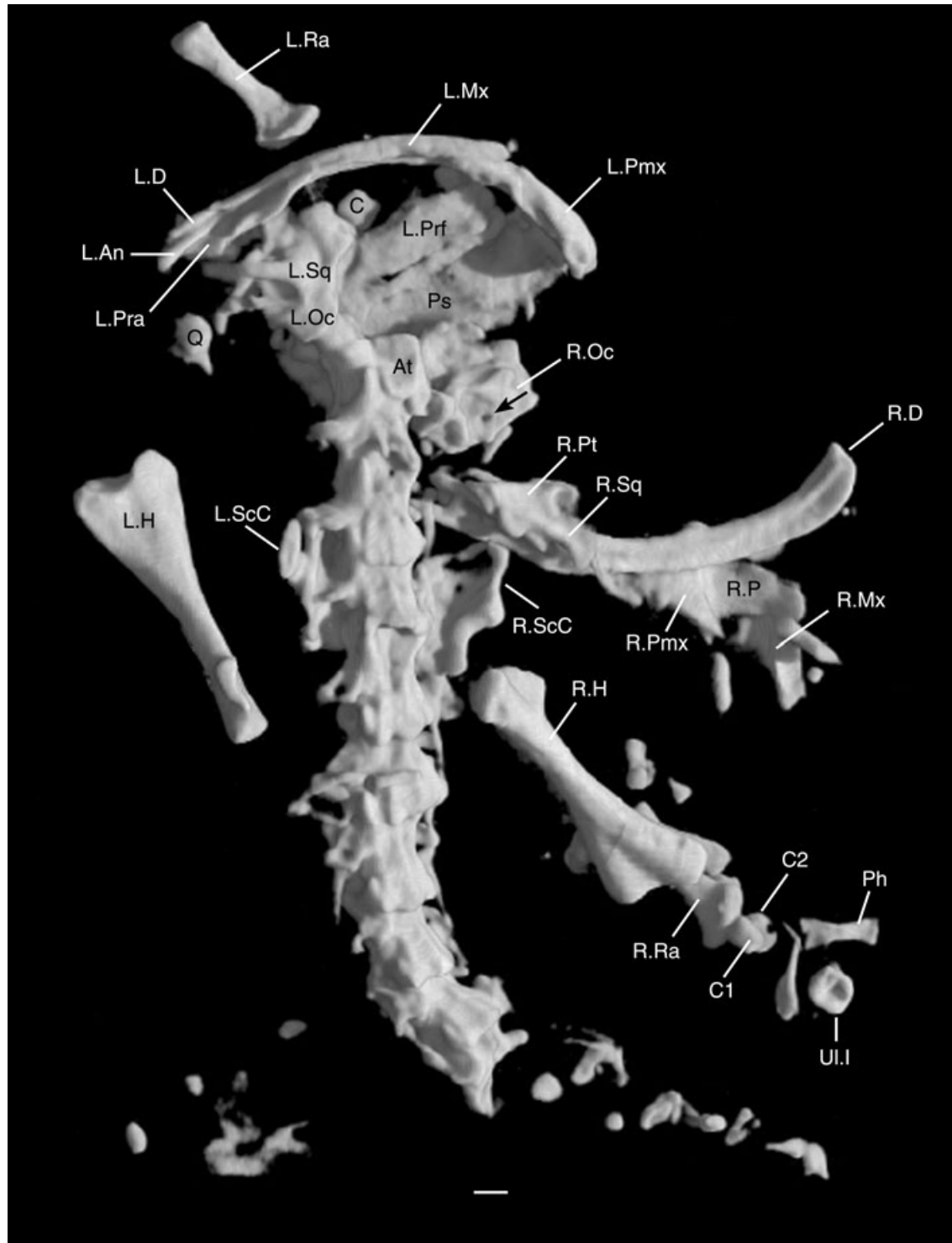

Figure 4. *Iridotriton hechti* gen. et sp. nov., DINO 16453a, digital reconstruction of dorsal surface based on high-resolution computed tomography. *Abbreviations:* At, atlas; C, C1-2, carpals; L.An, left angular; L.D, left dentary; L.H, left humerus; L.Mx, left maxilla; L.Oc, left otic capsule; L.Pmx, left premaxilla; L.Pra, left prearticular; L.Prf, left prefrontal; L.Ra, left radius; L.ScC, left scapulocoracoid; L.Sq, left squamosal; Ph, phalanx; Ps, parasphenoid; Q, quadrate; R.D, right dentary; R.H, right humerus; R.Mx, right maxilla; R.Oc, right otic capsule (small arrow points to foramen for endolymphatic duct); R.P, right parietal; R.Pmx, right premaxilla; R.Pt, right pterygoid; R.Ra, right radius; R.ScC, right scapulocoracoid; R.Sq, right squamosal; Ul.I, fused ulnare and intermedium. Scale bar = 1 mm.

trace of sculpture and provides no detail of articular surfaces for adjacent bones. The right bone has not been identified with confidence. It may be a partially obscured flat bone, the edge of which is exposed between the left margin of the parasphenoid and the left prefrontal. The frontals appear to have been slightly narrower than the parietals, but of similar length.

Parietals: the left parietal partially underlies the left frontal and prefrontal. The right has been carried out with other bones of this side and lies between the right premaxilla, maxilla, and dentary, extending under the last of these bones for a short distance. The bone is rectangular with at least one (anterior or posterior) straight margin. It is certainly not acutely tapered at either end and therefore probably did not extend far forward under the frontal. Neither parietal is sculptured.

Squamosal: the left bone is *in situ*, overlapping the braincase medially and the pterygoid distolaterally. It is roughly triangular, broad dorsally and tapers at its ventral tip. The posterior margin is curved. As preserved, the squamosal contacts only the braincase and not the parietal. The right element has not been identified with certainty, but it may be represented by a curved flange underlying the right pterygoid (?R.Sq, Fig. 6).

Vomer: this lies beneath the left jaw symphysis (visible only on the digital reconstructions; V in Fig. 5). If it is the left element, then it is *in situ* relative to the left dentary, but since the skeleton has partially disarticulated, the two bones have rotated to the left of the frame. The anterior margin [now directed to the left of Fig. 5 (= right side of body)] has two short surfaces meeting at a slight angle; presumably these met the premaxilla and maxilla. The lateral margin (now at the top) is embayed by the choana and then flares out lateral to it to form a postchoanal flange. The medial margin (now at the bottom) is strongly oblique suggesting the presence of an anterior palatine fontanelle.

Behind it, the posteromedial border (facing to the right of the figure) is relatively long and straight. Teeth are not visible, but this is probably an artefact of the resolution of the high resolution X-ray scanner, because dentary teeth are visible on the specimen but not on the scans (CT slices and reconstructions). An alternative explanation would be that this is the right bone, either turned 180° on its long axis so that the dorsal surface is exposed, or reversed so that the wider edge, now posterior, met the jaw margin, with the bone narrowing posteriorly (a better match for that of primitive living salamanders like cryptobranchids and hynobiids, S. E. Evans, pers. observ.). Conceivably, it

could be the left element, rotated both anteroposteriorly and dorsoventrally. No other bone shows such a radical displacement, but the vomers could have been seriously disrupted when the jaws were disarticulated and rotated outwards.

Pterygoid: the left pterygoid is largely obscured by the overlying squamosal in dorsal view, and by parts of the braincase ventrally. A distinct blade, presumably the posterolateral pterygoid process, extends ventrally beyond the squamosal and quadrate towards the lower jaw, whereas a more fragmentary process is directed anteriorly. From the underside of the specimen (digital reconstructions, Fig. 5), the bone appears more complex, and the medial surface was probably concave, but it is neither large nor strongly expanded. The right pterygoid may be represented by the irregular bone mass adjacent to the right otic elements. It is clearly bent in more than one plane, and curves around the edge of the mandible. Overlying it on the underside is a small, unidentified bony plate that also overlaps the jaw.

Parasphenoid: this has a long parallel-sided anterior rostrum that is overlapped ventrally by the vomer. Posteriorly, at the level of the braincase, the bone expands slightly to overlap the otic capsules, although there are no strong alae and no visible perforations for the internal carotid arteries. Dorsally, the parasphenoid forms the right boundary of the skull mass, and its dorsal surface is concave.

Quadrate: visible on the digital reconstructions as a small dense mass of bone displaced to the left side of the skull.

Braincase: in salamanders, this has two principal components: the sphenethmoid (= orbitosphenoid; Trueb, 1993) that underlies the frontal and attaches to the dorsal margin of the parasphenoid rostrum, and the otic capsule made up of the prootic, opisthotic, and exoccipital, or some combination of these three elements (Trueb, 1993). The sphenethmoid seems to be represented in *Iridotriton* by a long narrow element wedged between the skull roof (left frontal) and the parasphenoid rostrum on the left side (Fig. 5). It is perforated by a small foramen (perhaps for a branch of the ophthalmic division of the trigeminal nerve; Francis, 1934) and has a larger posterior notch for the optic nerve (these structures lie to the left and right of 'Sp', respectively, in Fig. 5, and are seen most clearly if the digital reconstructions are rotated).

The otic capsule is preserved on both sides of the skull. Its components are fused into a relatively large, rounded structure that extended beyond the confines of the parietal table. On the left side, the exoccipital is roughly *in situ* against the atlantal cotyle, although it has rotated laterally so that the exoccipital condyle

has disarticulated from the atlas. The otic capsule continues forward as a single unit into the prootic, with the squamosal overlapping the lateral and dorsolateral surfaces but not reaching the level of the parietal.

Seen in ventral view (Fig. 5), the otic capsule surrounds a rather bulbous vestibular cavity. The fenestra ovalis opens ventrolaterally and contains fragments of bone that probably pertain to the stapes. On the right side of the skull, the otic capsule is displaced and has rotated slightly. The opisthotic component is united with the exoccipital and prootic, but is delimited by sutures (although these must be at least partially closed as there is no displacement). Dorsally, the opisthotic (right otic capsule, Fig. 4) exposes a small distinct foramen (small arrow, Fig. 4) that opens from the inside of the vestibular cavity. This foramen is presumably for the endolymphatic duct (Francis, 1934).

Mandible

The left mandible is in articulation with, and largely obscured by, the maxilla and premaxilla of that side. The right mandible is displaced and exposed in lingual view to the side of the specimen.

The dentary has a narrow but relatively deep terminal symphysis and a long, but very narrow, Meckelian sulcus that is open throughout its length. The alveolar margin is separated from the subdental ridge by a deep groove, so that the tooth-bearing part of the jaw forms a rather shallow margin along the dorsal edge of the dentary. It bears a row of around 40 slender pedicellate teeth, but the tooth crowns are not clearly preserved in any position. On both sides, the dentary extends to the posterior end of the mandible, bracing the accessory bones from the labial side.

Between the rear of the dentary and the maxilla on the left side there are two distinct anteroposteriorly directed structures (Figs 4, 6). The more laterally placed of these is a narrow lamina with a thickened margin. It corresponds in structure and position to the angular in the living *Cryptobranchus* and hynobiids. The more medial structure has a dorsally expanded anterior coronoid process and a posterior edge that curves medially. It then continues ventrolaterally into a flange-like blade that lies parallel to the posterior pterygoid lamina. This is the prearticular-coronoid. On the right mandible, the angular is *in situ* at the rear of the bone, whereas the slender anterior tip of the prearticular is visible within the posterior half of the Meckelian canal (Fig. 5).

Axial skeleton

The axial skeleton is preserved in two parts. In 16453a (Figs 2, 4, 5), the atlas is preserved *in situ*. Following

it are eight complete vertebrae, fragments of a ninth (Ps 10, Fig. 2), and then impressions and fragments of a further four. Specimen 16453b (Fig. 3) preserves eight presacral vertebrae followed by a sacral, at least three caudosacrals, and one further isolated caudal. It is difficult to be certain of the relationship of the two blocks, but it seems likely that the first vertebrae preserved on 16453b (Ps10, Fig. 3) is part of the last vertebra on block 16543a, with the vertebrae following on 16453b responsible for the impressions on 16453a. Under this interpretation, there were a total of 17 presacrals. There may have been more, but there cannot have been fewer.

Atlas: this is preserved in dorsal and left lateral views but is otherwise obscured by the bones around it. Thus the presence of the interglenoid tuberosity cannot be confirmed, although, judging from the other features of the skeleton, it is likely to have been present in a caudate of this grade. The atlas is slightly shorter than the vertebra following it, and had a low neural arch with a midline crest but no spine, and a convex posterior margin. Anteriorly, the left cotyle remains in articulation with the exoccipital condyle. In lateral view, however, crushing obscures the detail. There is certainly at least a notch in the anterior margin of the atlas for the first spinal nerve (between the cotyle and the anterodorsal margin of the arch, Fig. 6), but whether it was a fully enclosed foramen or not is impossible to judge.

Postatlantal presacral vertebrae: the first eight postatlantal vertebrae have low neural arches with a middorsal keel and short horizontal spines that were directed posteriorly and were probably completed in cartilage (judging by the pitted distal tips). Ventrally, the centrum is rounded with no midline keel and only small anterior basapophyses. The centra form weak amphicoelous cylinders that probably developed ectochordally. There is no evidence of spinal nerve foramina in trunk vertebrae. The zygapophyses are strong and horizontal, whereas the rib-bearers are long and directed posterolaterally. On each, the dorsal and ventral rib facets have coalesced to form a single head, although there is a slight waisting of the surface in more posterior vertebrae. The ribs themselves are certainly single-headed and relatively long (equal or nearly equal to the length of the centrum). Most are very gracile, but the second and third postatlantal vertebrae bear more robust ribs for the support of the pectoral girdle. The centra of the posterior presacrals (16453b, Fig. 3) are also simple and spool-like, with neither median keels nor prominent basapophyses. At most, there is a slight bilateral thickening of the surface in the region of the basapophyses. The rib-bearers become weaker towards the sacrum.

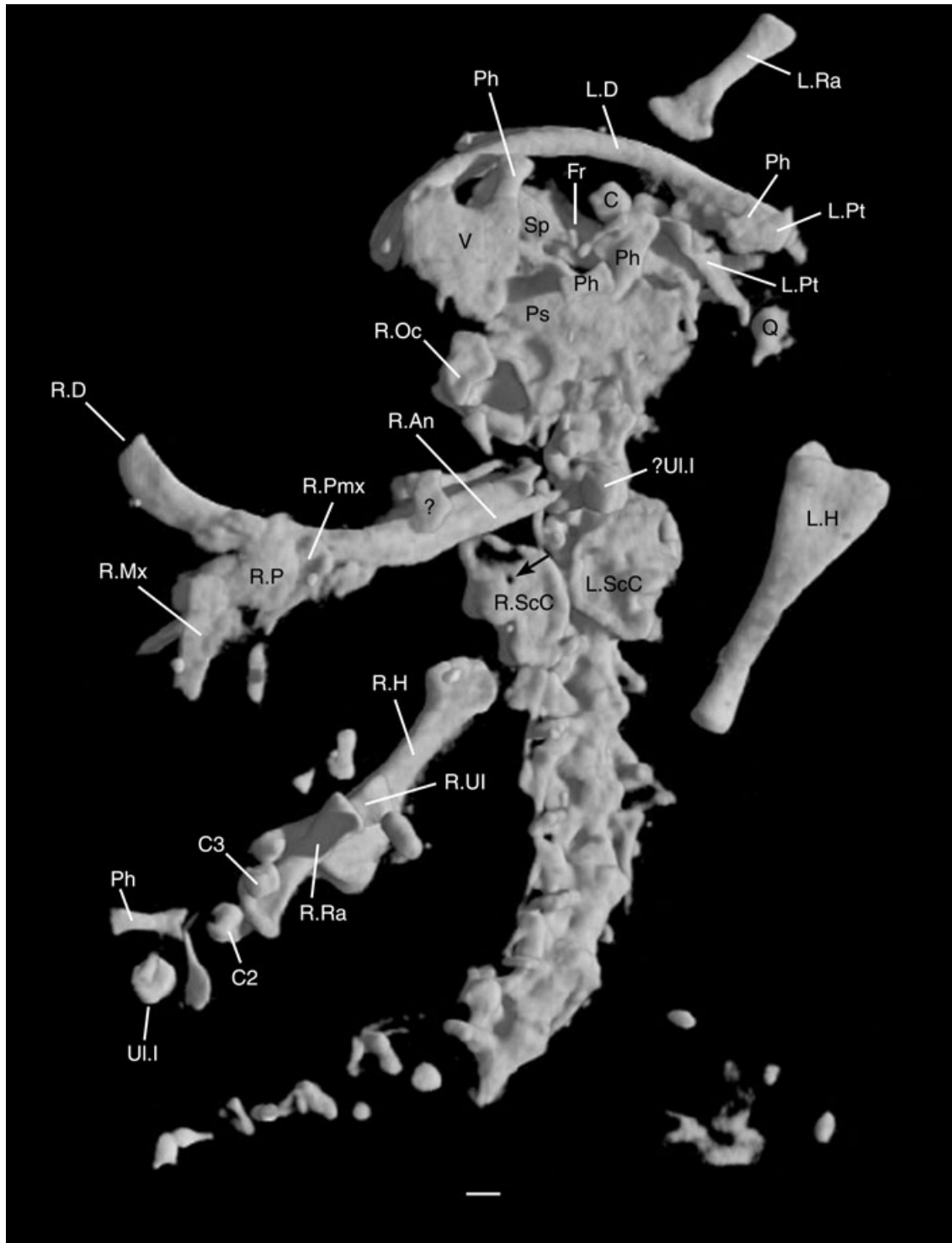

Figure 5. *Iridotriton hechti* gen. et sp. nov., DINO 16453a, digital reconstruction of ventral surface of specimen based on high-resolution computed tomography. *Abbreviations:* C, C2-3, carpals; Fr, frontal; L.D, left dentary; L.H, left humerus; L.Pt, parts of left pterygoid; L.Ra, left radius; L.ScC, left scapulocoracoid; Ph, phalanges; Ps, parasphenoid; Q, quadrate; R.An, right angular; R.D, right dentary; R.H, right humerus; R.Mx, right maxilla; R.Oc, right otic capsule; R.P, right parietal; R.Pmx, right premaxilla; R.Ra, right radius; R.ScC, scapulocoracoid (small arrow points to supracoracoid foramen); R.UI, right ulna; Sp, sphenethmoid; UI.I, fused ulnare and intermedium; V, vomer; ? unidentified fragment. Scale bar = 1 mm.

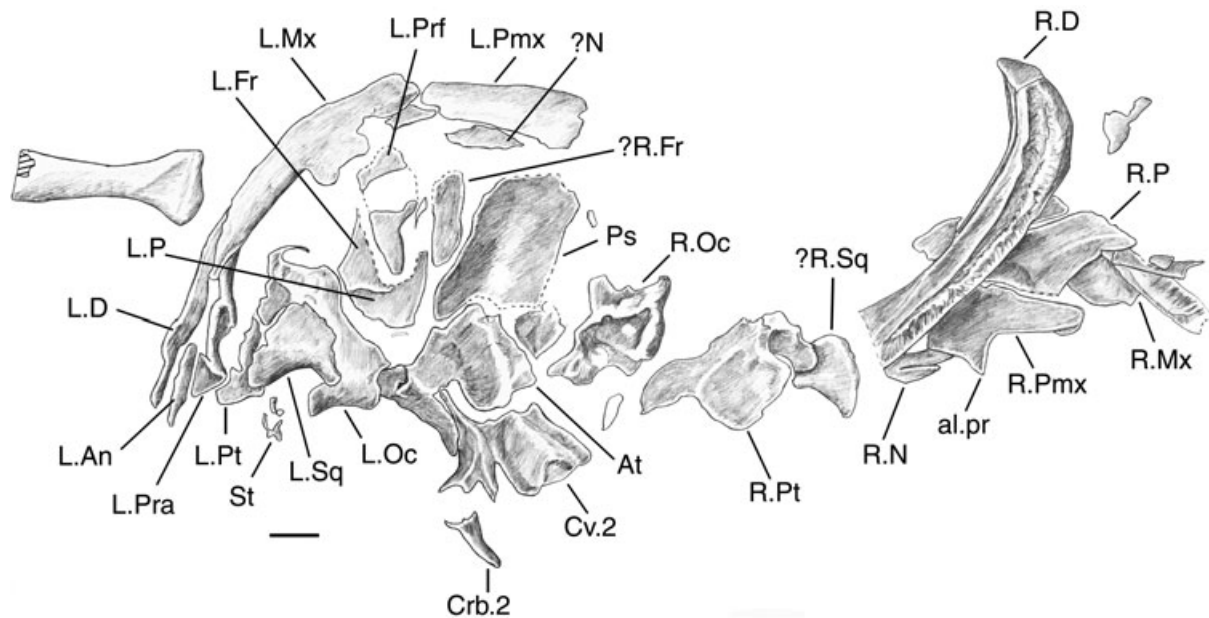

Figure 6. *Iridotriton hechti* gen. et sp. nov., DINO 16453a. Skull region, as exposed. *Abbreviations:* al.pr, alary process of premaxilla; At, atlas; Crb.2, rib of second vertebra; Cv.2, second vertebra; L.An, left angular; L.D, left dentary; L.Fr, left frontal; L.Mx, left maxilla; L.Oc, left otic capsule; L.P, parietal; L.Pmx, left premaxilla; L.Pra, left prearticular; L.Prfr, left prefrontal; L.Pt, left pterygoid; L.Sq, left squamosal; N, possible left nasal; Ps, parasphenoid; R.D, right dentary; ?R.Fr, possible right frontal; R.Mx, right maxilla; R.N, right nasal; R.Oc, right otic capsule; R.P, right parietal; R.Pmx, right premaxilla; R.Pt, right pterygoid; ?R.Sq, possible right squamosal; St, stapes. Scale bar = 1 mm.

Sacral vertebra: the sacral is separated from the last trunk vertebra and has rotated slightly, probably because of its relatively massive rib-bearers and the influence of the pelvic girdle and hind limb. The sacral ribs themselves have disarticulated and one is visible beside the femur.

Caudosacral vertebrae: behind the sacral vertebra and under the pelvic region, there are three caudosacral but they are preserved only in ventral view and yield little detail – except for the presence of rib-bearers and free ribs similar to those of the last trunk vertebrae.

Caudal vertebrae: one isolated caudal is preserved at the edge of the block (Fig. 7). This small vertebra has no spine and weak zygapophyses, but preserves a spinal nerve foramen in its posterior half.

Pectoral girdle and forelimb

Scapulocoracoid: the right and left scapulocoracoids are *in situ*, but partially obscured by the overlying vertebrae and ribs. They are therefore most clearly seen in the digital reconstructions (Figs 4, 5). The scapula and coracoid form a single ossification. The coracoids are robust semicircular plates that curve under the axial skeleton and are each perforated by a single supracoracoid foramen (clearest on the right, Fig. 5).

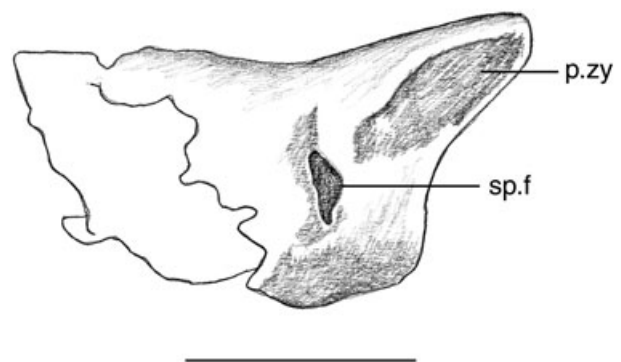

Figure 7. *Iridotriton hechti* gen. et sp. nov., DINO 16453b. Detail of caudal vertebra with spinal nerve foramen. *Abbreviations:* p.zy, posterior zygapophyses; sp.f, spinal nerve foramen. Scale bar = 1 mm.

There is no coracoid incisure and the two plates were almost in contact medially.

The scapula component is clearly visible in dorsal view (Fig. 4, left side) and is small in relation to the coracoid. The upper margin is straight and the anterior and posterior margins are strongly curved so that the narrow scapular blade is strongly waisted at its junction with the coracoid. The top of the blade is broken away on the right side. As preserved, the glenoid

is posterolateral in position, and deep, with its long axis orientated dorsoventrally. This suggests a degree of dorsoventral movement for the large humerus, as occurs in some modern salamanders in slow-gait terrestrial locomotion (Evans, 1946). Among modern salamander scapulocoracoids examined, the morphology of *Iridotriton* most closely resembles that of the terrestrial *Ambystoma* (S. E. Evans, pers. observ.).

Humerus: both humeri are preserved. The proximal and distal heads are at roughly 90° to one another, and the distal head is relatively massive compared to the slender humeral shaft. The proximal end bears an expanded crista ventralis humeri but no crista dorsalis. At the distal end, the condyles for articulation with the radius and ulna are not ossified, and it is clear from the embayed shape of the distal end that it bore a large cartilaginous joint surface.

Radius and ulna: the left radius lies adjacent to the left maxilla (Figs 2, 4, 5), whereas the right radius and ulna are visible only on the digital reconstructions (Figs 4, 5). Both bones have relatively narrow shafts and expanded ends, although the ulna is the more gracile element. They are roughly half the length of the humerus (R/H = 53%).

Carpus and manus: wrist and manus elements are preserved on both sides, but are disarticulated. There is one isolated carpal, probably from the left side, just behind the left dentary (Fig. 5). On the right side, three carpal elements are clearly preserved (digital reconstructions, Figs 4, 5), three (C1–3, Figs 4, 5) lie clustered around the distal ends of the ulna and radius, whereas a single, slightly larger element (Ul.I) is positioned further distally, close to a phalanx. This large rounded element has a small central perforation and matches the fused ulnare + intermedium of living salamanders (Francis, 1934; S. E. Evans, pers. observ.).

According to Francis (1934) the short canal marks the line of fusion between the two bones and conveys the perforans carpi artery (a second similar element lies in front of the left scapulocoracoid, Fig. 5). The three smaller carpals cannot be identified with any confidence. In the extant *Salamandra* (Francis, 1934), there are four ossified carpals in addition to the ulnare-intermedium: a centrale, a basale commune (representing a fusion of the first two distal carpals), and then a basale 3 and a basale 4, although more elements occur in some taxa.

Of the three distal elements in *Iridotriton*, C1 is the smallest and may be a basale; C2 is strongly concave along its long axis and could be a centrale. C3 is more cylindrical, with a small constriction around the midpoint. It is either another basale, or possibly a basale commune. If this latter is correct, then the carpal structure of *Iridotriton* (fused ulnare-intermedium,

large basale commune, small number of well ossified distal carpals/centrale) would be relatively derived. The phalangeal formula cannot be reconstructed: none of the digits is complete on the right side, and the phalanges of the left manus are scattered amongst the bones of the skull. Overall, however, the forelimb is robust and strongly ossified.

Pelvic girdle and hindlimb

Parts of the left hind limb and girdle are preserved but disarticulated.

Ilium: the left ilium is seen in medial view thus obscuring the structure and size of the acetabulum. The bone is small in comparison to the femur (although this is exaggerated in Fig. 3 by the edge-on view) and quite gracile. There is no trace of either ischiadic plate and these are presumably deep in the matrix (although this second block was not scanned).

Femur: this is of similar length to the humerus, but less robust. The proximal and distal heads are somewhat compressed and there is a distinct projecting proximal trochanter.

Tibia and fibula: as in the forelimb, the epipodials are short and stout, with the tibia the more robust of the two elements.

Tarsus and pes: a small number of scattered bones of the foot (metatarsals and short phalanges) are also preserved. The elements of the pes are larger and longer than those of the manus but the phalangeal formula cannot be reconstructed. There is one element beside the caudal vertebra that may be a tarsal.

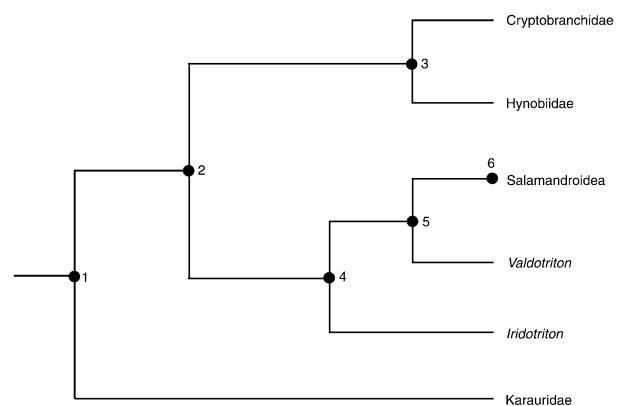

Figure 8. Phylogenetic tree showing suggested relationship of *Iridotriton* within Caudata. Node 1: Caudata; Node 2: Urodela (minimally ch. 9–12 in *Iridotriton*, see text); Node 3: Cryptobranchioidea; Node 4: stem-salamandroids (minimally ch. 15 in *Iridotriton*); Node 5: unnamed clade (Evans & Milner, 1996; ch. 1, 3–4); Node 6: Salamandroidea (minimally ch. 8).

DISCUSSION

PHYLOGENETIC POSITION

Relationships amongst extant salamanders

Under traditional classifications (e.g. Estes, 1981; Duellman & Trueb, 1986; Milner, 1988) nine or ten clades of living salamanders are recognized: Cryptobranchidae, Hynobiidae, *Dicamptodon*, Rhyacotritonidae, Sirenidae, Amphiumidae, Proteidae, Salamandridae, Ambystomatidae, and Plethodontidae. There is a general agreement that Cryptobranchidae and Hynobiidae (if monophyletic) are grouped within the Cryptobranchioidea (Larson & Dimmick, 1993; Cryptobranchiformes of Milner, 2000) and that most or all of the remainder fall within a second supergroup, the Salamandroidea (Larson & Dimmick, 1993; Salamandriiformes of Milner, 2000).

Sirenidae are problematic and there is disagreement as to whether these taxa should be regarded as aberrant, but derived, salamandroids (e.g. Estes, 1981) or as members of a primitive clade that is the sister group to Cryptobranchioidea + Salamandroidea (Neocaudata; Larson & Dimmick, 1993). Milner (1983, 1988, 2000) supported the outgroup position of sirenids, as did Duellman & Trueb (1986, albeit with some reservation), Larson & Dimmick (1993), Hedges & Maxson (1993), and Hay *et al.* (1995).

Trueb (1993: fig. 6.9) presented a tree derived from unpublished work by R. Cloutier in which sirenids are nested well within salamandroids as the sister group of plethodontids (with salamandrids, ambystomatids, and proteids + amphiumids as successive outgroups). Most recently, the analysis of Gao & Shubin (2001) also nested sirenids within salamandroids, as a sister group to proteids and, in one tree, to amphiumids. However, the pedomorphic specializations of each of these three families may be distorting the result.

On the relationships of the remaining groups, there is little consensus. *Dicamptodon* and rhyacotritonids have been variously considered as primitive (Duellman & Trueb, 1986) or derived, with *Dicamptodon* frequently classified with ambystomatids (e.g. Estes, 1965; Larson & Dimmick, 1993; Milner, 2000; Gao & Shubin, 2001; but see Hedges & Maxson, 1993), and rhyacotritonids with plethodontids and amphiumids (e.g. Milner, 1983, 2000; Hillis, 1991; Hedges & Maxson, 1993; Gao & Shubin, 2001; combined consensus).

Proteids are variously placed as primitive (Milner, 1983; Duellman & Trueb, 1986; Hillis, 1991); in a clade with salamandrids, ambystomatids and *Dicamptodon* (Larson & Dimmick, 1993); or with *Dicamptodon* alone (Hay *et al.*, 1995); whereas salamandrids and ambystomatids are sometimes linked (e.g. Milner, 1983, 2000; Larson & Dimmick, 1993; Gao & Shubin, 2001) and sometimes not (Hay *et al.*, 1995). Milner (1983) and Hillis (1991) had ambystomatids as the sis-

ter group of salamandrids, whereas Duellman & Trueb (1986) placed ambystomatids as the sister group of plethodontids, and the molecular analysis of Hay *et al.* (1995) found no link between any of the three.

For the purposes of this discussion, however, the intricacies of crown-group relationships are not important, except with respect to *Dicamptodon*, since the latter shows a number of primitive characters (separate angular and prearticular, spinal nerve foramina only in atlas and tail) whose significance and polarity are affected by its position in the phylogeny. The same applies to sirenids.

The position of Iridotriton

Iridotriton shows a combination of primitive and derived characters that permit some discussion of its phylogenetic position:

1. Premaxillae separate, broad with strong but short alary process that did not make a major contribution to the dorsal roof. This is the condition in karaurids and in some primitive members of both cryptobranchoids and salamandroids (hynobiids, cryptobranchids, *Dicamptodon*). Most salamandroids show a more derived condition in which the alary process is longer and meets the frontals.
2. Maxilla with relatively short dorsal process. This is a primitive character found in karaurids, cryptobranchoids and *Dicamptodon* (Trueb, 1993).
3. Premaxilla with alary process that must have abutted the nasal rather than overlain it, as in karaurids. Many cryptobranchoids also have a short dorsal process, as does *Dicamptodon* amongst salamandroids. This is undoubtedly a primitive trait. In derived caudates, the long dorsal process separates the right and left nasals in the midline. In the Early Cretaceous *Valdotriton* (Evans & Milner, 1996), a long dorsal process partly divides the two nasal anlagen of each side.
4. Separate prearticular and angular bones in the lower jaw, but no free coronoid. The possession of separate prearticular and angular bones is a primitive character found in karaurids (Estes, 1981), basal Chinese salamanders (Gao & Shubin, 2001), and cryptobranchoids. In salamandroids and stem-salamandroids (*Valdotriton*), the bones are fused into a single compound prearticular element. A separate coronoid bone is found in sirenids (Estes, 1965; Trueb, 1993) and also in proteids, as well as some fossil salamanders (*Sinerpeton*, *Laccotriton*) considered either basal (Gao & Shubin, 2001) or cryptobranchoid (Wang, 2000b).
5. Free ribs on at least the anteriormost three caudals. Their presence on anterior caudal verte-

- brae is a primitive trait, although Gao & Shubin (2003) cite the reduction in number of these ribs to 2–4? as a derived cryptobranchid character. In *Iridotriton*, only three anterior caudals are preserved.
6. Prefrontal present, slender and elongate. Since the dorsal process of the maxilla is short, it is likely to have contacted only the prefrontal and not the frontal. This is the primitive condition (Gao & Shubin, 2001; supplementary data, character 33) found in karaurids and many extant salamanders. Exceptions include *Cryptobranchus*, in which the frontals extend forward between the prefrontals to meet the maxilla, and some plethodontids where the prefrontal is lost.
 7. Vomer large, with choanal notch and evidence of median palatine fenestra. A short broad vomer is a primitive feature found in karaurids, primitive Chinese salamanders (*Sinerpeton*, *Laccotriton*; Gao & Shubin, 2001) and some members of both major extant lineages (e.g. cryptobranchids, *Dicamptodon*). In more derived taxa, there is a tendency toward posterior elongation of the vomer over the parasphenoid (Trueb, 1993). In conjunction with the latter condition, there is a change in the pattern of the vomerine tooth row from essentially transverse (either immediately behind the premaxillary row, e.g. *Cryptobranchus*; or midway through the vomer, e.g. *Valdotriton*) to longitudinal. The left vomer of *Valdotriton* is visible in the digital reconstructions at the front of the palate. It is short but the tooth row cannot be seen, presumably because the teeth were small and below the resolution of the scan (individual tooth positions are also not visible on the dentary in the scans, but are visible under the microscope).
 8. ?Paired nasal anlagen. Living salamanders vary as to whether they possess one or two nasal anlagen on each side of the skull midline. Two anlagen are generally considered to be primitive (e.g. Larson, 1991; Larson & Dimmick, 1993; Trueb, 1993). In some hynobiids (e.g. *Ranodon*, *Salamandrella*), these anlagen lie medial and lateral to the alary process of the premaxilla (Rose, 2003). This appears also to be the condition in cryptobranchids, but Rose (2003) argues that the lateral anlage has actually expanded into the region medial to the alary process in this group. According to Larson (1991) and Larson & Dimmick (1993), some salamander taxa retain only the medial anlage (e.g. sirenids), some the lateral anlage (most salamandroids), and some (e.g. *Rhyacotriton*, *Necturus*) lose the nasal completely. *Valdotriton* retains paired anlagen, conjoined posteriorly, and the same condition may have been present in *Iridotriton*.
 9. Gracile skull bones without sculpture. Fully metamorphosed karaurid salamanders like *Karaurus* (Ivachnenko, 1978) and *Marmorerpeton* (Evans & Waldman, 1996) have thick, heavily sculptured skull roofing bones, not unlike those of ancestral temnospondyls. In most derived caudates, as in *Iridotriton*, the skull bones are thin with little, if any, sculpture.
 10. Triangular squamosal, wider dorsally than ventrally, meets braincase but not parietal and is essentially mediolateral in orientation. The articulation with the braincase leaves a gap between the squamosal and parietal that permits the adductor muscles to pass back across the braincase, lengthening their action (Estes, 1981). The squamosal of karaurids shows the primitive condition. It has a thick, geometric dorsal portion that abuts the parietal, leaving no space for the muscles (adductor mandibulae internus, pseudotemporalis superficialis portion; Carroll & Holmes, 1980).
 11. No evidence of a quadratojugal in the cheek region. Karaurids primitively retain this element (Ivachnenko, 1978; Estes, 1981) but it is lost in crown-group salamanders.
 12. Notochordal ectochordal vertebrae. This is a primitive character within postkaraurid salamanders where the vertebrae are formed from membrane bone. Karaurids have heavily ossified vertebrae that appear to have an endochondral component (S. E. Evans, pers. observ.).
 13. Scapulocoracoid a single ossification, small low scapula and large coracoid plate. This is a problematic character. Sirenids have separate scapula and coracoid ossifications, and this has been regarded as a primitive character (Duellman & Trueb, 1986) supporting the placement of sirenids outside the cryptobranchoid-salamandroid node (e.g. Milner, 1988, 2000; Larson & Dimmick, 1993). However, as stem-frogs (*Triadobatrachus*, *Czatkobatrachus*; Borsuk-Bialynicka & Evans 2000) and stem-salamanders (*Marmorerpeton*, S. E. Evans, pers. observ.) have a single scapulocoracoid plate, the sirenid condition is likely to be secondarily derived, not primitive.
 14. Single-headed or conjoined ribs on most vertebrae. Karaurid salamanders have two headed ribs and this primitive condition is retained in salamandroids. In most cryptobranchoids (but see Milner, 2000) the two heads have coalesced into a single rib facet and this is often regarded as a derived character state of the group (Duellman & Trueb, 1986; Larson & Dimmick, 1993). The distribution pattern, however, may be more complex than that because rib-bearers with conjoined surfaces are present in both *Iridotriton* and a small sala-

mander ('salamander B') from the Middle Jurassic locality of Kirtlington in Oxfordshire, England (Evans *et al.*, 1988; Evans & Milner, 1994), neither of which shows other cryptobranchoid characters (other than primitive states). Most of the rib-bearers also have conjoined heads in a second Kirtlington caudate, 'salamander A', that appears to be a paedomorphic karaurid. Further work is needed on the developmental history of this trait, but the evidence suggests that it is not uniquely cryptobranchoid.

15. At least one caudal vertebra with spinal nerve foramina. This is a character formulated by Edwards (1976), and discussed by several later authors (e.g. Larson & Dimmick, 1993). In the primitive tetrapod condition, the spinal nerves emerge intervertebrally, but some salamanders have the spinal nerves emerging through the body of the vertebra itself (intravertebral). Karaurids show the primitive condition. In cryptobranchoids, the only nerve emerging intravertebrally is that of the atlas (see above), making the possession of this atlantal foramen a defining character of crown-group urodeles. Within salamandroids, *Dicamptodon* and *Rhyacotriton* have spinal nerve foramina in the tail, but there are notches in the sacral, and larger notches in caudosacrals suggesting that the spinal nerve has already moved from its intervertebral position. The Cretaceous *Valdotriton* also has spinal nerve foramina in at least the anterior caudal vertebrae, but not in the postatlantal presacrals. In more derived salamandroids (ambystomatids, plethodontids, salamandrids), spinal nerve foramina also exist in the trunk vertebrae – creating an apparent trend towards greater numbers of these foramina (Duellman & Trueb, 1986). However, proteids lack any spinal nerve foramina behind the atlas (primitive or derived?), whereas sirenids have them almost throughout the body. If sirenids are genuinely basal, then this implies either that foramina evolved independently within the group, or that trunk foramina are primitive rather than derived, with varying patterns of loss. Under the traditional view (e.g. Larson & Dimmick, 1993; Milner, 2000), the presence of spinal nerve foramina in the tail of *Iridotriton*, but not the trunk, places it in a similar position (with respect to this character) as *Valdotriton*. However, if the character is unstable, this feature may be phylogenetically uninformative.
16. Parietals broad, midline contact, short. The parietals are not fully exposed, but they are relatively simple rectangular bones with a midline contact. It is unlikely that they were strongly overlapped by the frontals (as, for example, in cryptobran-

chids). Short parietals are found in most extant salamanders. The cryptobranchoid condition is derived.

17. Otic capsule fully ossified with exoccipital and prootic forming strong mass; opisthotic appears conjoined but with a visible suture. The bones of the otic capsule are separate in cryptobranchoids and sirenids, but also in some living salamandroids, including *Dicamptodon*, *Rhyacotriton*, and amphiumids (Trueb, 1993). In proteids, as in *Iridotriton*, the opisthotic is discrete from the combined prootic/exoccipital (although conjoined in *Iridotriton*) whereas all three bones are fused in ambystomatids, salamandrids, plethodontids and, apparently, the Early Cretaceous *Valdotriton*. Whether or not this is a phylogenetically useful character remains to be seen; it may simply vary with levels of ossification in different caudate lineages.
18. Parasphenoid without internal carotid foramina. Internal carotid foramina are present (the primitive condition) in the lateral alae of the parasphenoid in karaurids, cryptobranchoids, and *Dicamptodon*; they are absent in sirenids, *Valdotriton* and most salamandroids (plethodontids, salamandrids, some ambystomatids) (Trueb, 1993).
19. Carpals and tarsals ossified, with a compound ulnare + intermedium. The carpus of *Iridotriton* may have been relatively derived with a small number of large robust elements. The ulnare and intermedium had certainly fused. This compound ulnare + intermedium appears to be a derived character of salamandroids (Shubin, Wake & Crawford, 1995).
20. Unfused margins of the Meckelian fossa behind the symphysis. In most salamanders, the Meckelian fossa is closed for at least some distance behind the symphysis, but the polarity of the character is not clear. This may be an autapomorphy of *Iridotriton*.

Recent hypotheses of caudate relationships (e.g. Duellman & Trueb, 1986; Milner, 1988; Evans & Milner, 1996; Gao & Shubin, 2001, 2003) provide a basis for discussion of the position of *Iridotriton*, using the characters listed above.

Iridotriton shares a number of primitive features with basal caudates, including karaurids, some cryptobranchoids, and some salamandroids (ch. 1–7). However, known karaurids differ from urodeles (= crown-group caudates) in several important features, notably: heavy cranial sculpture; the absence of an adductor groove on the squamosal or between it and the parietal; the retention of a quadratojugal; heavily built vertebrae, with a possible endochondral

component; and the absence of a spinal nerve notch or foramen in the atlas (*Marmorerpeton*, Evans *et al.*, 1988; condition uncertain in *Karaurus* and *Kokartus*). A tuberculum interglenoideum is absent in *Marmorerpeton*, but apparently present in *Kokartus*.

Iridotriton resembles urodeles in all of these characters for which it can be coded (ch. 9–12). It has a spinal nerve foramen or notch in the atlas, but the polarity of the latter character is somewhat problematic. Although stem-salamanders lack this feature, a foramen is present in basal members of two other lissamphibian groups (caecilians; Evans & Sigogneau-Russell, 2001. Albanerpetontids; Estes, 1981) and there is a notch for the spinal nerve in the atlas of the stem-frog *Czatkobatrachus* (Evans & Borsuk-Białynicka, 1998). This suggests the absence of a foramen in karaurids might be a peculiarity of that group, rather than a primitive character state. Nonetheless, the combination of other features (ch. 9–13) allows placement of *Iridotriton* on at least the urodelan stem.

As outlined above, the position of sirenid salamanders (stem or crown) is problematic, and this affects the polarity of characters such as the co-ossification of the scapulocoracoid (ch. 13: Milner, 1983; Larson & Dimmick, 1993) and the presence and distribution of spinal nerve foramina (ch. 15: Edwards, 1976). This makes it difficult to assess the relative positions of sirenids and *Iridotriton*.

Most current classifications (e.g. Milner, 1988, 2000; Larson & Dimmick, 1993) separate crown-group urodeles into two major clades: the Cryptobranchoidea (cryptobranchids and hynobiids) and the Salamandroidea (all other salamanders). There is some debate as to the monophyly of Cryptobranchoidea and of Hynobiidae (e.g. Trueb, 1993), although recent work by Gao & Shubin (2001, 2003) found support for the clade.

Cryptobranchoid salamanders are mostly characterized by the retention of primitive characters, including: low alary processes of the premaxillae and paired nasal anlagen; retention of a separate angular and prearticular in the lower jaw; and absence of a spinal nerve foramen in any postatlantal vertebra. The one frequently cited derived skeletal character is the coalescence of the rib-bearers into a single-head (ch. 14), but this is problematic, and one hynobiid (*Onychodactylus*; Okajima, 1908 in Milner, 2000) reportedly has double-headed rib-bearers.

Salamandroids are characterized by the fusion of the prearticular and angular into a single element, the presence of a single nasal anlage, and of spinal nerve foramina in at least some of the caudal vertebrae (extending to the trunk in derived clades, but lost secondarily in proteids, Edwards, 1976; Good & Wake, 1992). The presence of spinal nerve foramina in the tail of *Iridotriton* (ch. 15) supports its placement

within salamandroids, as do the imperforate parasphenoid (ch. 18) and the fused ulnare + intermedium (ch. 19).

The most completely known early Euramerican salamander, in terms of well-preserved specimens, is the Early Cretaceous *Valdotriton* (Evans & Milner, 1996) from the Barremian locality of Las Hoyas, Spain. *Valdotriton* has caudal spinal nerve foramina and a single prearticular-angular bone, although the nasal anlagen are not fully fused. For this reason, it was placed on the salamandroid stem (Evans & Milner, 1996). It thus provides a reference point for *Iridotriton*. Like *Valdotriton*, *Iridotriton* may have had paired nasal anlagen connected posteriorly (ch. 8), but unlike *Valdotriton*, the alary process of the premaxilla is short and the prearticular and angular were separate. The balance of characters therefore suggests a position for *Iridotriton* within salamandroids, but on the stem below *Valdotriton*.

BIOGEOGRAPHY

According to the vicariance model proposed by Milner (1983), caudates arose within a united Laurasian landmass. Subdivision of that landmass left two stem-caudate populations, providing the ancestral stock of cryptobranchoids in Asia and of salamandroids in Euramerica. At the time Milner's paper was written, the Jurassic and Early Cretaceous record of caudates was extremely poor. It has improved over the last two decades but, with the notable exception of the Late Jurassic *Karaurus* (Kazakhstan; Ivachnenko, 1978), all demonstrably Jurassic salamander material recovered has been fragmentary (Hecht & Estes, 1960; Evans *et al.*, 1988; Evans, 1992; Evans & Milner, 1994; Evans & Waldman, 1996). In addition, most Middle and Late Jurassic specimens described to date are referable to the stem-caudate group Karauridae (*Karaurus* [Ivachnenko, 1978], Kazakhstan. *Kokartus* [Nessov, 1981, Nessov *et al.*, 1996], Kirghizia. *Marmorerpeton* [Evans & Waldman, 1996; Evans *et al.*, 1988], UK, Portugal. Kirtlington 'salamander A' [Evans, 1992; Evans & Milner, 1994; Evans & Waldman, 1996; indet. material, Estes, 1981], USA). Under Milner's (1983) vicariance model, this suggests a rather slow diversification within the new Asian and Euramerican landmasses.

Gao & Shubin (2001) offered an alternative biogeographical hypothesis on the basis of two new Chinese fossil salamanders, *Laccotriton* and *Sinerpeton*, reportedly of Late Jurassic age. Preliminary analyses placed both taxa on the caudate stem above karaurids (but see Wang, 2000b). Arguing that all known Jurassic taxa (i.e. the new genera and the karaurids *Karaurus* and *Kokartus*) were Asian (and primitive), Gao & Shubin (2001) proposed an Asian origin for Caudata.

This implied that caudates reached Euramerica from Asia only after the reestablishment of a land route in the late Early Cretaceous, as manifested by the appearance of genera like *Valdotriton* in the Barremian of Spain (Evans & Milner, 1996).

However, the Asian origin hypothesis set aside the Middle and Late Jurassic record of caudates in Euramerica (Hecht & Estes, 1960; Estes, 1981; Evans *et al.*, 1988; Evans, 1992; Evans & Milner, 1994; Evans & Waldman, 1996). Furthermore, the reported Late Jurassic age of *Laccotriton* and *Sinerpeton* is based on an Early Tithonian date for the underlying Zhangjiakou Formation (Gao & Shubin, 2001). More detailed geological work (Davis *et al.*, 2001) has given an Early Cretaceous age to these beds, making *Sinerpeton* and *Laccotriton* roughly contemporaneous with the Hauterivian-Barremian (Zhou, Barrett, & Hilton, 2003; Wang, 2004) salamanders of the Jehol biota (?cryptobranchoids *Liaoxitriton*; Dong & Wang, 1998. *Jeholotriton*; Wang, 2000a), and with European salamanders of the same age (Dollo, 1884; Evans *et al.*, 1995; Evans & Milner, 1996; Milner & Evans, 1998).

More recently, Gao & Shubin (2003) described a superb collection of articulated salamanders (*Chunerpeton tianyiensis*) from the Jiulongshan Formation of Inner Mongolia, China, which they date as Middle Jurassic (Bathonian) in age. They place *Chunerpeton* firmly within crown-group Cryptobranchidae, a position requiring an early divergence of cryptobranchids and hynobiids (if the latter are monophyletic; Trueb, 1993), perhaps before the initial separation of Euramerica and Asia. However, there are again concerns with respect to the age of the Jiulongshan Formation (Zhonghe Zhou & Yuan Wang, pers. comm. to Evans, September 2003), and the beds may be considerably younger than Middle Jurassic. Thus the early stages of cryptobranchoid evolution are still obscure, but there is no evidence that the caudate record of Asia predates that of Euramerica.

Fragmentary crown-group salamander material (*Kiyatriton*) has also recently been described from the Aptian-Albian of Western Siberia (Averianov & Voronkevich, 2002), but it is not assignable beyond Urodela *indet.*

If we are correct in our attribution of *Iridotriton* to the salamandroid stem, then it provides qualified support for Milner's (1983) vicariance model because it extends the history of the clade in Euramerica back into the Late Jurassic. However, additional material and further analyses are required to establish the rate and pattern of diversification more fully, and more detailed studies of the Chinese salamanders (e.g. Dong & Wang, 1998; Wang, 2000a, b, 2004) are needed to determine their affinities.

In fact, *Iridotriton* may not be the earliest stem-salamandroid. Isolated jaws, atlantes, and postatlan-

tal trunk vertebrae of another small salamander are known from the Middle Jurassic British locality of Kirtlington, although they have been discussed in the literature only as 'Salamander B' (Evans & Milner, 1994; Evans & Waldman, 1996). The bones of this small salamander are very gracile. There is a fully developed tuberculum interglenoideum on the atlas, although this element is notched for the spinal nerve, rather than perforate. The presacral vertebrae resemble those of *Iridotriton* in having conjoined rib-bearers, but the caudals are unknown.

LIFESTYLE

Iridotriton is surprisingly robust for its size, with full ossification of the limb elements including the carpals and tarsals (often remaining unossified in living and fossil taxa), but not the joint surfaces of the long bones. The pectoral girdle is extensively ossified with strong coracoid plates that probably approached one another, or met, in the ventral midline. The humerus is relatively massive, with a greatly expanded distal head and strong proximal crests. The trunk is short and the tail lacks any development of tall neural or haemal spines. All these features argue for a predominantly terrestrial salamander with powerful limbs and a wide, shallow head. The teeth are numerous and very small, indicating a microphagous diet.

ACKNOWLEDGEMENTS

We owe a debt of gratitude to the High Resolution X-ray Computed Tomography Facility at UT Austin for scanning the specimen (especially Matt Colbert and Tim Rowe), and to the NSF who funded the scan. Thanks also to Scott Madsen (Dinosaur National Monument) for the initial mechanical preparation of the specimen; to Dr Jim Gardner (Royal Tyrrell Museum, Canada) for information about the second Morrison taxon; to Drs Barry Clarke (Zoology Department, The Natural History Museum) and Helen Chatterjee (Grant Museum, UCL) for the loan of comparative salamander material; to Drs Zhonghe Zhou and Yuan Wang (Institute of Vertebrate Palaeontology and Palaeoanthropology, Beijing) for information on the dating of Chinese deposits; and to Jane Pendjiky (Anatomy, UCL) for help in the preparation and labelling of electronic images. Drs Jim Gardner and Andrew Milner reviewed an earlier version of the manuscript and we thank them for their helpful comments.

REFERENCES

- Averianov AO, Voronkevich AV. 2002.** A new crown-group salamander from the Early Cretaceous of Western Siberia. *Russian Journal of Herpetology* **9**: 209–214.

- Bolt JR. 1991.** Lissamphibian origins. In: Schulze H-P, Trueb L, eds. *Origins of the higher groups of tetrapods*. Ithaca, NY: Comstock Publishing, 194–222.
- Borsuk-Białynicka M, Evans SE. 2002.** The scapulocoracoid of an Early Triassic stem-frog from Poland. *Acta Palaeontologica Polonica* **47**: 79–96
- Cannatella DC, Hillis DM. 1993.** Amphibian relationships: phylogenetic analysis of morphology and molecules. In: Cannatella DC, Hillis DM, eds. Amphibian relationships. Phylogenetic analysis of morphology and molecules. *Herpetological Monographs* **7**: 1–7.
- Carroll RL, Holmes R. 1980.** The skull and jaw musculature as guides to the ancestry of salamanders. *Zoological Journal of the Linnean Society* **68**: 1–40.
- Davis GA, Zheng Y, Wang C, Darby BJ, Zhang C, George G. 2001.** Mesozoic tectonic evolution of the Yanshan fold and thrust belt, with emphasis on Hebei and Liaoning provinces, northern China. *Geological Society of America, Memoir* **194**: 171–197.
- Dollo L. 1884.** Note sur le batracien de Bernissart. *Bulletin du Musée Royal d'Histoire Naturelle de Belgique* **3**: 85–96.
- Dong Z, Wang Y. 1998.** A new urodele (*Liaoxitriton zhongjiani* gen. et sp. nov.) from the Early Cretaceous of Western Liaoning Province, China. *Vertebrata Palasiatica* **36**: 159–172 [In Chinese with an English summary].
- Duellman WE, Trueb L. 1986.** *Biology of amphibians*. New York: McGraw-Hill.
- Edwards JL. 1976.** Spinal nerves and their bearing on salamander phylogeny. *Journal of Morphology* **148**: 305–328.
- Engelmann GF, Callison G. 1998.** Mammalian faunas of the Morrison Formation. In: Carpenter K, Chure DJ, Kirkland JI, eds. The Upper Jurassic Morrison Formation: an interdisciplinary study. Part 1. *Modern Geology* **23**: 343–380.
- Ensom PC, Evans SE, Milner AR. 1991.** Amphibians and reptiles from the Purbeck Limestone Formation (Upper Jurassic) of Dorset. *Contributions to the Paleontological Museum, University of Oslo* **364**: 19–20.
- Estes R. 1965.** Fossil salamanders and salamander origins. *American Zoologist* **5**: 319–334.
- Estes R. 1969.** Prosirenidae, a new family of fossil salamanders. *Nature* **224**: 87–88.
- Estes R. 1981.** Gymnophiona, Caudata. In: Wellnhofer P, ed. *Handbuch der Paläoherpelologie* 2. Stuttgart: Gustav Fischer.
- Estes R, Sanchiz B. 1982.** Early Cretaceous lower vertebrates from Galve (Teruel), Spain. *Journal of Vertebrate Paleontology* **2**: 21–39.
- Evans FG. 1946.** The anatomy and function of the forelimb in salamander locomotion. *Anatomical Record* **95**: 257–281.
- Evans SE. 1992.** Small reptiles and amphibians from the Forest Marble (Middle Jurassic) of Dorset. *Proceedings of the Dorset Natural History and Archaeological Society* **113**: 201–202.
- Evans SE, Borsuk-Białynicka M. 1998.** A stem-frog from the Early Triassic of Poland. *Acta Paleontologica Polonica* **43**: 573–580.
- Evans SE, Chure DJ. 1998a.** Morrison lizards: structure, relationships and biogeography. In: Carpenter K, Chure DJ, Kirkland JI, eds. The Upper Jurassic Morrison Formation: an interdisciplinary study. Part 1. *Modern Geology* **23**: 35–48.
- Evans SE, Chure DJ. 1998b.** Paramacelodid lizards from the Jurassic Morrison Formation at Dinosaur National Monument, Utah. *Journal of Vertebrate Paleontology* **18**: 99–114.
- Evans SE, McGowan G. 2002.** An amphibian assemblage from the Purbeck Limestone Group. *Special Papers in Paleontology* **68**: 103–119.
- Evans SE, McGowan G, Milner AR, Sanchiz B. 1995.** Amphibians. In: Melendez MN, ed. *Las Hoyas. A lacustrine Konservat-Lagerstätte, Cuenca, Spain*. Madrid: Ediciones Universidad Complutense de Madrid, 51–53.
- Evans SE, Milner AR. 1993.** Frogs and salamanders from the Upper Jurassic Morrison Formation (Quarry Nine, Como Bluff) of North America. *Journal of Vertebrate Paleontology* **13**: 24–30.
- Evans SE, Milner AR. 1994.** Middle Jurassic microvertebrate assemblages from the British Isles. In: Fraser NC, Sues H-D, eds. *The shadow of the dinosaurs: Early Mesozoic tetrapods*. Cambridge: Cambridge University Press, 303–321.
- Evans SE, Milner AR. 1996.** A metamorphosed salamander from the Early Cretaceous of Las Hoyas, Spain. *Philosophical Transactions of the Royal Society of London B* **351**: 627–646.
- Evans SE, Milner AR, Mussett F. 1988.** The earliest known salamanders (Amphibia, Caudata): a record from the Middle Jurassic of England. *Geobios* **21**: 539–552.
- Evans SE, Sigogneau-Russell D. 2001.** A stem-group caecilian (Amphibia: Lissamphibia) from the Lower Cretaceous of Morocco. *Palaeontology* **44**: 259–273.
- Evans SE, Waldman M. 1996.** Small reptiles and amphibians from the Middle Jurassic of Skye, Scotland. In: Morales M, ed. *The Continental Jurassic. Museum of Northern Arizona Bulletin* **60**: 219–226.
- Feller AE, Hedges SB. 1998.** Molecular evidence for the early history of living amphibians. *Molecular Phylogenetics and Evolution* **9**: 509–516.
- Fox RC, Naylor BG. 1982.** A reconsideration of the relationships of the fossil amphibian *Albanerpeton*. *Canadian Journal of Earth Sciences* **19**: 118–128.
- Francis ETB. 1934.** *The anatomy of the salamander*. Oxford: Clarendon Press.
- Fraser NC, Wu X-C. 1998.** Sphenodontians from the Brushy Basin member of the Morrison Formation in Dinosaur National Monument. In: Carpenter K, Chure DJ, Kirkland JI, eds. The Upper Jurassic Morrison Formation: an interdisciplinary study. Part 1. *Modern Geology* **23**: 17–34.
- Gao KQ, Cheng ZW, Xu X. 1998.** First report of a Mesozoic urodele from China. *Chinese Geology* **1998** (1): 40–41 [In Chinese].
- Gao KQ, Shubin NH. 2001.** Late Jurassic salamanders from northern China. *Nature* **410**: 574–577.
- Gao K, Shubin NH. 2003.** Earliest known crown-group salamanders. *Nature* **422**: 424–428.
- Good DA, Wake DB. 1992.** Geographic variation and speciation in the torrent salamanders of the genus *Rhyacotriton*

- (Caudata: Rhyacotritonidae). *University Of California Publications in Zoology* **126**: 1–91.
- Gradstein FW, Agterberg FP, Ogg JJ, Hardenbol J, Van Veen P, Thierry J, Huang Z. 1995.** A Triassic, Jurassic and Cretaceous time scale. In: Berggren WA, Kent DV, Aubry MP, Hardenbol J, eds. *Geochronology time scales and global stratigraphic correlation*. Society for Sedimentary Geology Special Publication 54, 95–126.
- Hay JM, Ruvinsky I, Hedges SB, Maxson LR. 1995.** Phylogenetic relationships of amphibian families inferred from DNA sequences of mitochondrial 12S and 16S ribosomal RNA genes. *Molecular Biology and Evolution* **12**: 928–937.
- Hecht MK, Estes R. 1960.** Fossil amphibians from Quarry Nine. *Postilla* **46**: 1–19.
- Hedges SB, Maxson IR. 1993.** A molecular perspective on lissamphibian phylogeny. In: Cannatella DC, Hillis DM, eds. *Amphibian relationships. Phylogenetic analysis of morphology and molecules*. *Herpetological Monographs* **7**: 27–42.
- Henrici AC. 1998.** New anurans from the Rainbow Park microsite, Dinosaur National Monument, Utah. In: Carpenter K, Chure DJ, Kirkland JI, eds. *The Upper Jurassic Morrison Formation: an interdisciplinary study. Part 1. Modern Geology* **23**: 1–16.
- Hillis DM. 1991.** The phylogeny of amphibians: current knowledge and the role of cytogenetics. In: Green DM, Sessions SK, eds. *Amphibian cytogenetics and evolution*. London: Academic Press, 7–32.
- Ivachnenko M. 1978.** Urodeles from the Triassic and Jurassic of Soviet Central Asia. *Palaeontologicheskii Zhurnal* **1978**: 84–89 [In Russian].
- Jenkins FE, Walsh DM. 1993.** An early Jurassic caecilian with limbs. *Nature* **365**: 246–250.
- Kowallis BJ, Christiansen EH, Deino AL, Peterson F, Turner CE, Kunk MJ, Obradovich JD. 1998.** The age of the Morrison Formation. In: Carpenter K, Chure DJ, Kirkland JI, eds. *The Upper Jurassic Morrison Formation: an interdisciplinary study. Part 1. Modern Geology* **22**: 235–260.
- Larson A. 1991.** A molecular perspective on the evolutionary relationships of salamanders. *Evolutionary Biology* **25**: 211–277.
- Larson A, Dimmick WW. 1993.** Phylogenetic relationships of the salamander families: an analysis of congruence among morphological and molecular characters. In: Cannatella, DC, Hillis, DM, eds. *Amphibian relationships. Phylogenetic analysis of morphology and molecules*. *Herpetological Monographs* **7**: 77–93.
- Laurin M, Reisz RR. 1997.** A new perspective on tetrapod phylogeny. In: Sumida SS, Martin KLM, eds. *Amniote origins. Completing the transition to land*. San Diego: Academic Press, 9–59.
- McGowan G, Evans SE. 1995.** Albanerpetontid amphibians from the Cretaceous of Spain. *Nature* **373**: 143–145.
- Milner AC, Evans SE. 1998.** First report of lizards and amphibians from the Wealden (Lower Cretaceous of England). In: Lucas SG, Kirkland JI, Estep JW, eds. *Lower and Middle Cretaceous terrestrial ecosystems*. *New Mexico Museum of Natural History and Science* **14**: 173–176.
- Milner AR. 1983.** The biogeography of salamanders in the Mesozoic and early Caenozoic: a cladistic-vicariance model. In: Sims RW, Price JH, Whalley PES, eds. *Evolution, time and space: the emergence of the biosphere*. London: Academic Press, 431–468.
- Milner AR. 1988.** The relationships and origin of living amphibians. In: Benton MJ, ed. *The phylogeny and classification of the tetrapods*, vol. 1. *Amphibians, reptiles, birds*. Systematics Association Special Volume 35a. Oxford: Clarendon Press, 59–102.
- Milner AR. 2000.** Mesozoic and Tertiary Caudata and Albanerpetontidae. In: Heatwole H, Carroll RL, eds. *Amphibian Biology*, Vol. 4. *Palaeontology*. Chipping Norton, New South Wales: Surrey Beaty, 1413–1444.
- Nessov LA. 1981.** Cretaceous salamanders and frogs of Kizylkum Desert. *Academy of Sciences of the U.S.S.R. Zoological Institute Proceedings* **101**: 57–88 [In Russian].
- Nessov LA. 1988.** Late Mesozoic amphibians and lizards of Soviet Middle Asia. *Acta Zoologica Cracovienska* **31**: 475–486.
- Nessov LA, Fedorov PV, Potanov DO, Golovyeva LS. 1996.** The structure of the skulls of caudate amphibians collected from the Jurassic of Kirgizstan and the Cretaceous of Uzbekistan. *Vestnik Sankt-Petersburgskogo Universiteta, Geologia* **7**: 3–11 [In Russian].
- Nevo E. 1964.** Fossil urodeles in early Lower Cretaceous deposits of Makhtesh Ramon, Israel. *Nature* **201**: 415–416.
- Nevo E, Estes R. 1969.** *Ramonellus longispinus*, an early Cretaceous salamander from Israel. *Copeia* **1969**: 91–123.
- Rage J-C, Roček Z. 1989.** Redescription of *Triadobatrachus massinoti* (Piveteau, 1936) an anuran amphibian from the Early Triassic. *Palaeontographica* **A206**: 1–16.
- Rose CS. 2003.** The developmental morphology of salamander skulls. In: Heatwole H, Davies M, eds. *Amphibian biology*, Vol. 5. *Osteology*. Chipping Norton, New South Wales: Surrey Beaty, 1686–1783.
- Ruta M, Coates MI, Quicke DLJ. 2003.** Early tetrapod relationships revisited. *Biological Reviews* **78**: 251–345.
- Shubin N, Wake DB, Crawford AJ. 1995.** Morphological variation in the limbs of *Taricha granulosa* (Caudata: Salamandridae): evolutionary and phylogenetic implications. *Evolution* **49**: 874–884.
- Trueb L. 1993.** Patterns of cranial diversity among the Lissamphibia. In: Hanken J, Hall BK, eds. *The skull, Vol. 2. Patterns of structural and systematic diversity*. Chicago: The University of Chicago Press, 255–343.
- Wang Y. 2000a.** A new salamander (Amphibia: Caudata) from the Early Cretaceous Jehol Biota. *Vertebrata Palasiatica* **38**: 100–103.
- Wang Y. 2000b.** Amphibians in the Jehol Biota from North-eastern China. *Vertebrata Palasiatica* **38** (Suppl.): 32–33.
- Wang Y. 2004.** A new Mesozoic caudate (*Liaoxitriton dao-hugoensis* sp. nov.) from Inner Mongolia, China. *Chinese Science Bulletin* **49**: 858–860.
- Zhou Z, Barrett PM, Hilton J. 2003.** An exceptionally preserved Lower Cretaceous ecosystem. *Nature* **421**: 807–814.