

# Practical applications of IIF

As a building block towards a digital National Collection

*Webinar 2, 11 June 2021*

## IIF all the things

*What goes into providing IIF for millions of items? Or even a National Collection? Tom Crane looks at large-scale IIF implementation, with particular focus on Wellcome Collection.*

*Tom Crane*

*Technology Director, Digirati*

[cultural-heritage.digirati.com](http://cultural-heritage.digirati.com)

*@tomofthenehill*

# Most Manifests are built by machines

- There are 100s of millions of digital objects represented by Manifests.
- As most of these are books, there are **billions** of Canvases.

METS  
MARC  
CIDOC-CRM  
DUBLIN CORE  
Etc  
Etc  
Etc



EWART'S LINEN FACTORY, BELFAST, 24-08-1914



National Library of Ireland  
Public Domain



Photos: Christy Henshaw

# The era before IIF... c. 2012

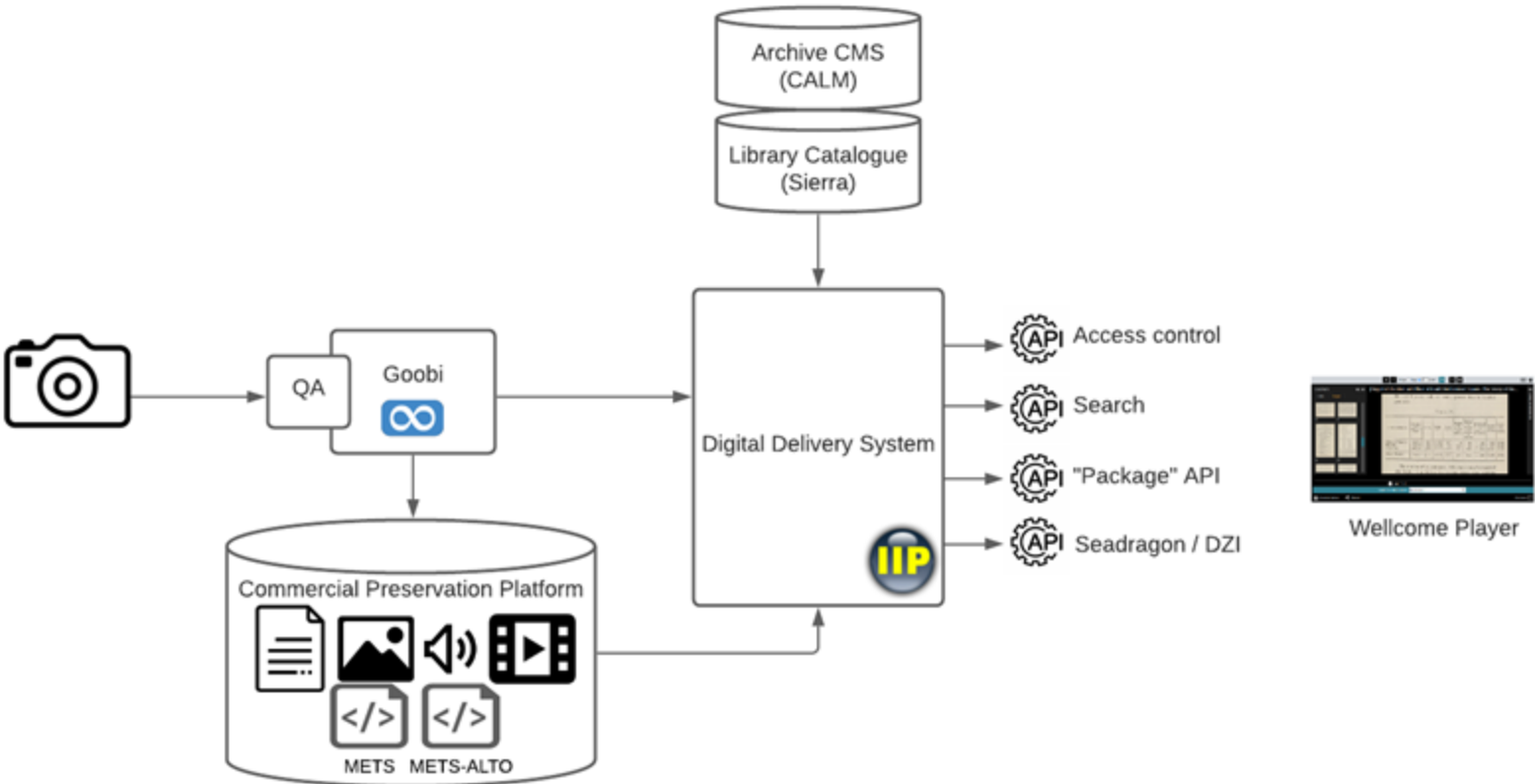

# Shiny IIF Overcoat

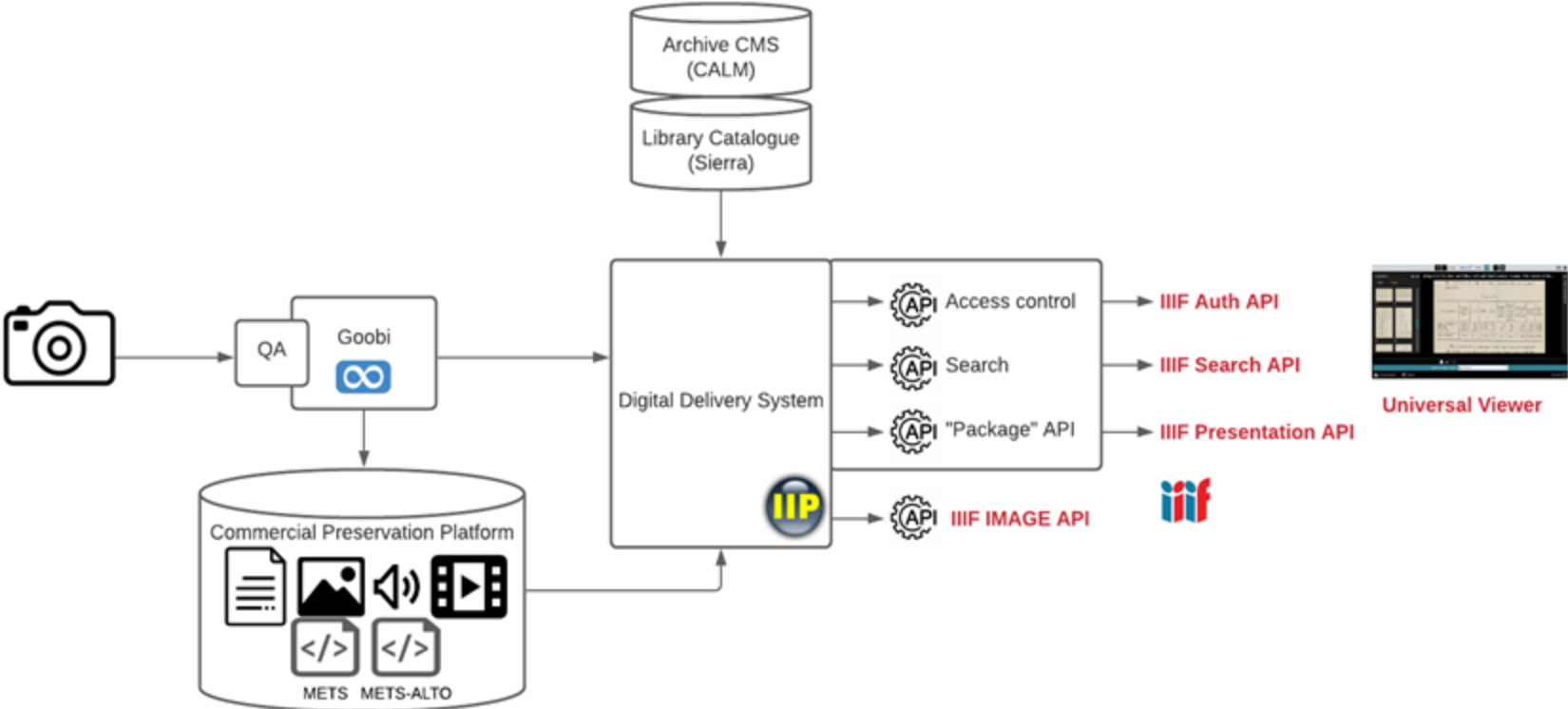

# DLCS - Asset Delivery as a commodity service

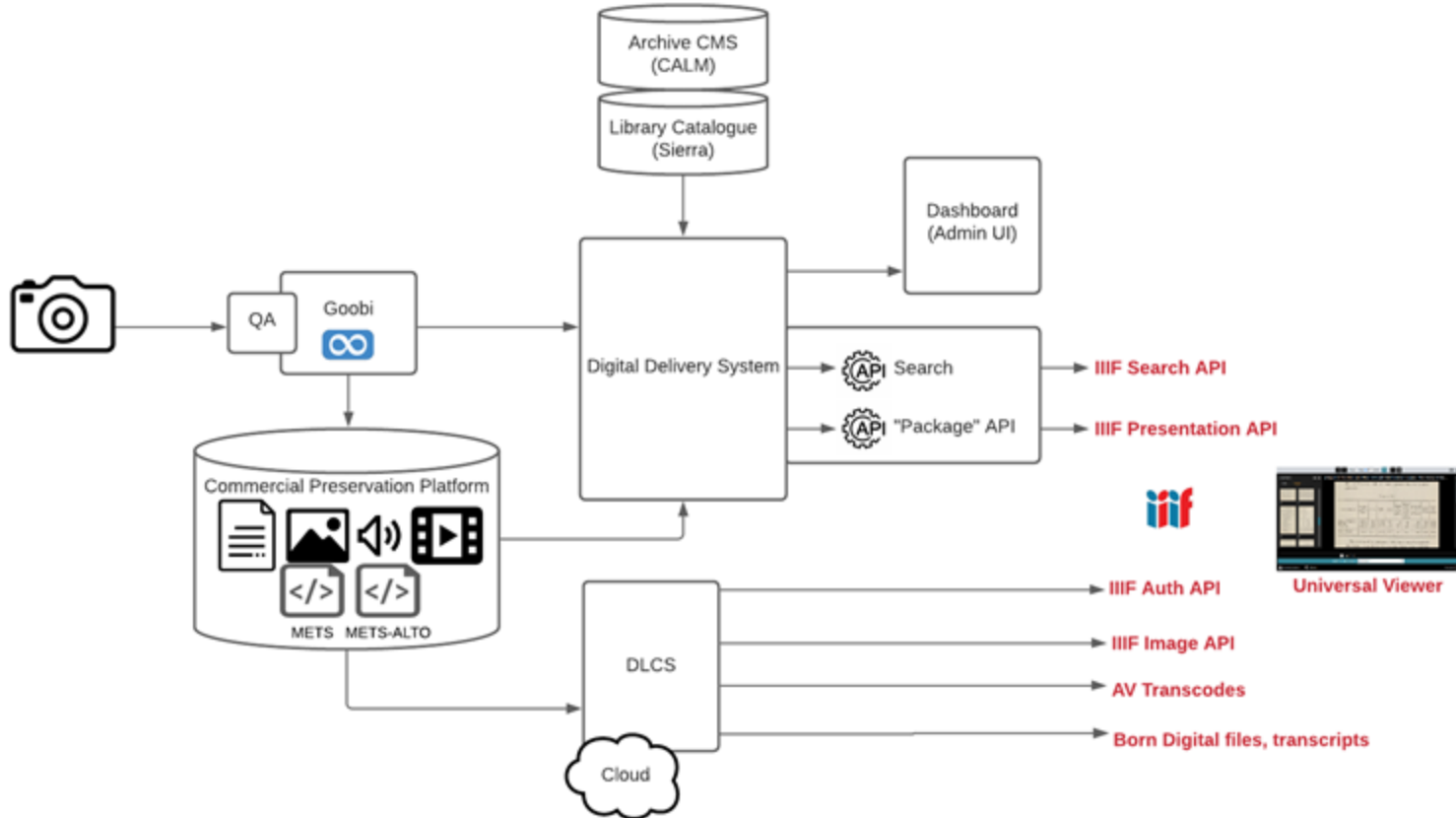

# New Storage Service

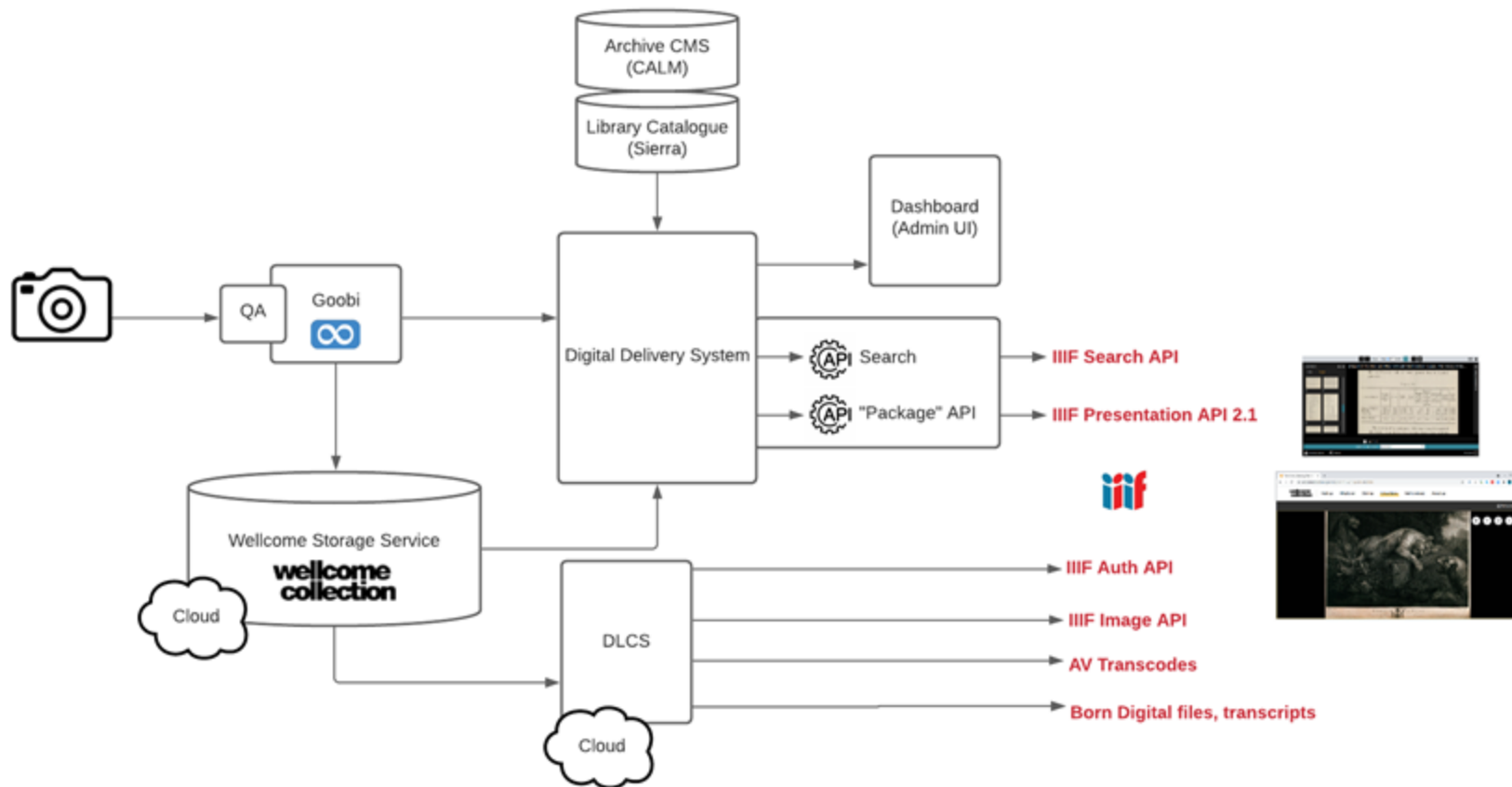

# Cloud everything, and IIF 3

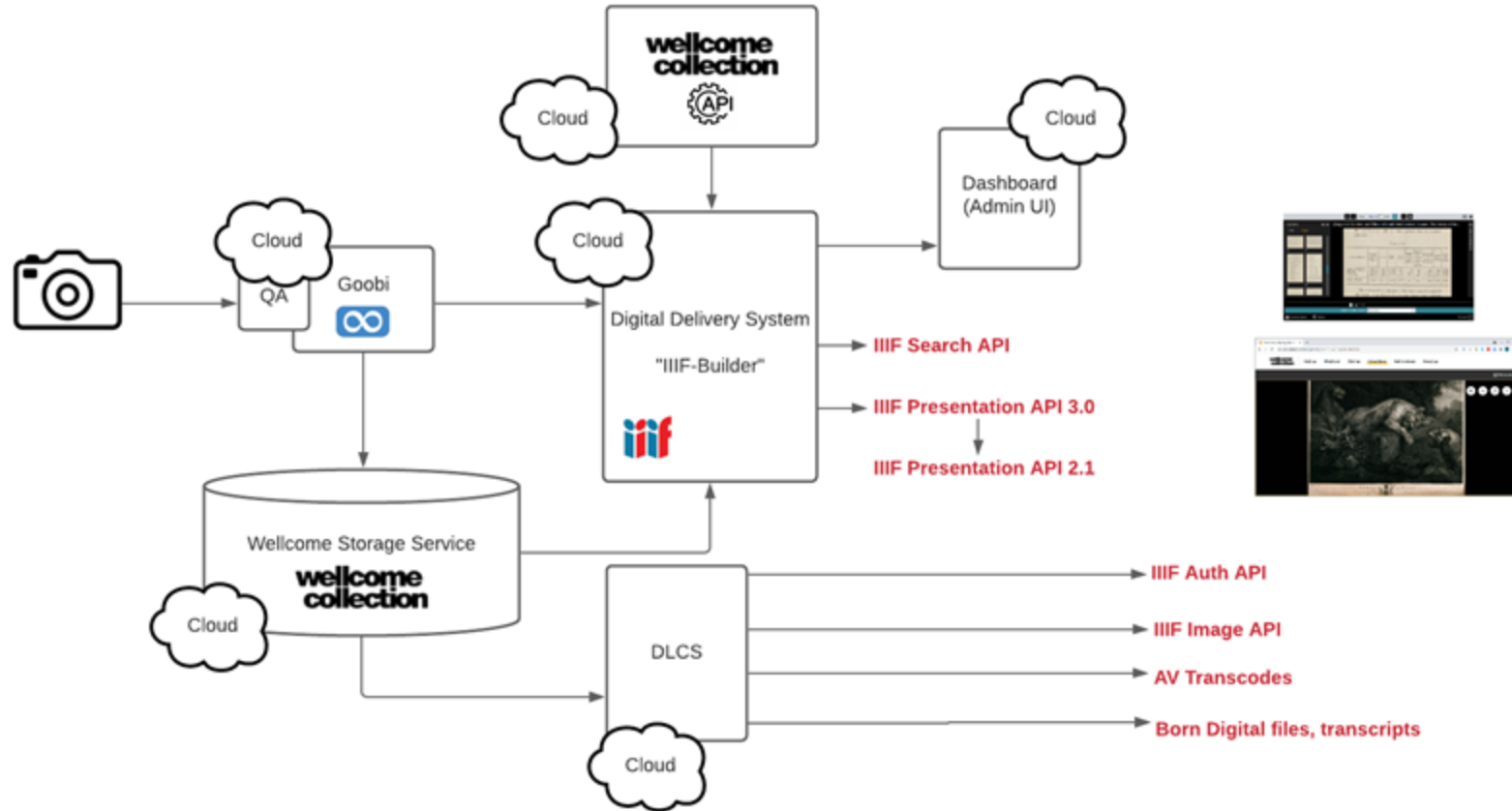



## DLCS - Asset Delivery as a commodity service

- Tell me about an image and I will provide a IIIF Image API service for it
- Tell me about an AV resource and I will provide web-friendly derivatives for it
- I can provide the IIIF Authentication API for all these resources
- I can do this for other types of file too, where a derivative is not needed - like PDFs

Space 20: Dixons 1985 · D · x Universal Viewer x +

portal.dics.digirati.io/spaces/details/20

The Portal Search Sign out

- Home
- Queue
- Spaces
- Storage
- Origins
- Access control
- Named queries
- Users
- API Keys

## Space 20: Dixons 1985

Space is IIF Manifest

[IIF Manifest](#) [Universal Viewer](#)

n1	Name
0	<a href="#">01.jpg</a>

Recent

- Home
- Desktop
- Documents
- Downloads
- Music
- Pictures
- Videos
- Rubbish Bin
- Other Locations

Home git tomcrane dixons1985 jpg



01.jpg 02.jpg 03.jpg 04.jpg

05.jpg 06.jpg 07.jpg 08.jpg

09.jpg 10.jpg 11.jpg 12.jpg

13.jpg 14.jpg 15.jpg 16.jpg

# Isn't that an easier way to make a manifest?

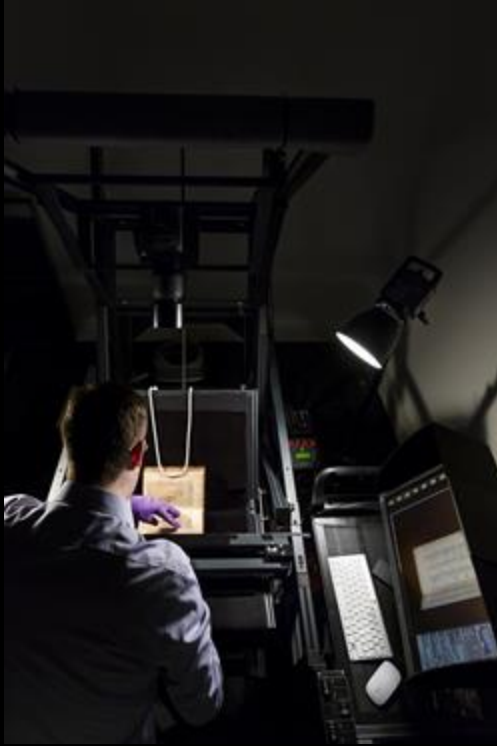

The screenshot shows a web browser window with the URL `portal.dcs.gtritec.com/spaces/Details/9`. The page title is "Space 9: drop-test-1". The interface includes a sidebar with navigation options: Home, Queue, Space, Storage, Origins, Access control, Named queries, Users, and API Keys. The main content area features a "Space is IP Manifest" section with a table of manifests. The table has columns for "id", "Name", and "Created", and a "Table Order" button. The table contains four rows of data:

id	Name	Created	Table Order
0	<a href="#">00.jpg</a>	04/09/2021 16:43:16	⏪ ⏩ ⏴ ⏵
1	<a href="#">13m7MAGu7uL.jpg</a>	04/04/2021 07:55:49	⏪ ⏩ ⏴ ⏵
2	<a href="#">atb.jpg</a>	04/04/2021 07:40:06	⏪ ⏩ ⏴ ⏵
3	<a href="#">BMC_20110211_144766.jpg</a>	04/04/2021 08:05:22	⏪ ⏩ ⏴ ⏵



# Observability and instrumentation

Home Workflow Jobs Queue Status Types Stop DLCS Queue: 0

## b19991903 - [U.S. House Science and Astronautics Committee - International Science Policy]

Archive (image/jpeg)

- Work page
- View v2 in Library UV
- View v2 in Mirador
- View v3 in current UV
- View v3 in Mirador
- IIIF Validator

Catalogue API  
Encore record

DLCS Preview Manifest  
DLCS Preview Manifest in UV  
IIIF Manifest (preview)  
IIIF Manifest (live)

Permitted operations:  
- currentViewAs.jpg  
- wholeImageLowResAs.jpg  
- wholeImageHighResAs.jpg  
- entireDocumentAsPdf

Storage Manifest  
 Storage Map (versions)  
 METS file

Mods: Requires registration 1

### Jobs

- Goobi Call Info
- Simulate Goobi Call
- 04/08/2021 04:29:24 88
- Force Reingest

88 assets of type image/jpeg

Order	Label	Dimensions	Access	ALTO	DLCS	
1	-	2327 x 3567	Requires registration		b19991903_JDW_02_17_0027_001.jp2	
2	-	3255 x 2549	Requires registration		b19991903_JDW_02_17_0027_002.jp2	
3	-	3255 x 2549	Requires registration		b19991903_JDW_02_17_0027_003.jp2	
4	-	3255 x 2549	Requires registration		b19991903_JDW_02_17_0027_004.jp2	
5	-	3255 x 2549	Requires registration		b19991903_JDW_02_17_0027_005.jp2	
6	-	3255 x 2549	Requires registration		b19991903_JDW_02_17_0027_006.jp2	
7	-	3255 x 2549	Requires registration		b19991903_JDW_02_17_0027_007.jp2	
8	-	3256 x 2549	Requires registration		b19991903_JDW_02_17_0027_008.jp2	
9	-	3256 x 2549	Requires registration		b19991903_JDW_02_17_0027_009.jp2	
10	-	3256 x 2549	Requires registration		b19991903_JDW_02_17_0027_010.jp2	
11	-	3256 x 2549	Requires registration		b19991903_JDW_02_17_0027_011.jp2	
12	-	3256 x 2549	Requires registration		b19991903_JDW_02_17_0027_012.jp2	
13	-	3256 x 2549	Requires registration		b19991903_JDW_02_17_0027_013.jp2	
14	-	3256 x 2549	Requires registration		b19991903_JDW_02_17_0027_014.jp2	
15	-	3256 x 2549	Requires registration		b19991903_JDW_02_17_0027_015.jp2	
16	-	3256 x 2549	Requires registration		b19991903_JDW_02_17_0027_016.jp2	
17	-	3255 x 2549	Requires registration		b19991903_JDW_02_17_0027_017.jp2	
18	-	3255 x 2549	Requires registration		b19991903_JDW_02_17_0027_018.jp2	
19	-	3255 x 2549	Requires registration		b19991903_JDW_02_17_0027_019.jp2	
20	-	3255 x 2549	Requires registration		b19991903_JDW_02_17_0027_020.jp2	
21	-	3255 x 2549	Requires registration		b19991903_JDW_02_17_0027_021.jp2	
22	-	3255 x 2549	Requires registration		b19991903_JDW_02_17_0027_022.jp2	
23	-	3255 x 2549	Requires registration		b19991903_JDW_02_17_0027_023.jp2	
24	-	3255 x 2549	Requires registration		b19991903_JDW_02_17_0027_024.jp2	

# Why do all this?

Mainly for the publisher to use the material themselves

- Probably in one “canonical” way

- But then later, in more specific additional ways

Then for other people to use it, with or without the knowledge of the publisher

- By making derived presentations - mashups, visualisations, creative reuse, reinterpretation

- Or for taking it into other IIF-compatible software

  - for crowdsourcing

  - for research purposes

And perhaps, contributing to aggregators like Europeana or DPLA; other environments for Discovery and exploration

And perhaps, a **National Collection**



[Home](#)

[About](#)

[Contribute](#)

[Help](#)

## Advanced Search

Title

Creator

Year From:

Year To:



Publisher

Place of publication

Required formats

- Plain Text
- IIIF
- ALTO-XML
- PDF
- TEI

Search



[Home](#)

[About](#)

[Contribute](#)

[Help](#)

## Advanced Search

[Edit search](#)

### [Piff! Paff! Pouf!: A Musical Cocktail](#)

Jean Schwartz , Stanislaus Stange , William Jerome Shapiro, Remick 1904

Internet Archive Books

Download: [PDF](#) [IIIF](#) [Plain-text](#)

### [The Cocktail Party December 1st-4th 19??](#)

Internet Archive Books

Download: [PDF](#) [IIIF](#) [Plain-text](#)

### [The cocktail book : a sideboard manual for gentlemen.](#)

Knowles, Frederic Lawrence John Macqueen London 1902

Wellcome Collection

Download: [PDF](#) [IIIF](#) [Plain-text](#)

### [Recipe book of the Wyche family containing culinary, medical and miscellaneous recipes](#)

National Library of Scotland

Download: [PDF](#) [IIIF](#)



The cocktail book : a sideboard manual for gentlemen.

Knowles, Frederic Lawrence, 1869-1905.

Date 1902

[Catalogue details](#) →

[Licence and credit](#) >

[Contents](#) >

Search within this item  
angostura bitters



60 results

2 instances found on image 21 / 80 (page 7)

...ing is necessary as regards the Bitters, in consequence of the unscrupulous way in which these have been imitated, [see also the original Dr. Sager's Angostura Bitters](#) ... [Angostura Bitters](#) that the delicious flavour and tonic properties of the well-made cocktail are due. Cocktails: "syrup" referred to in many of the "Vr" receipts is a...

1 instance found on image 23 / 80 (page 9)

... handy, as it saves the trouble of dissolving the sugar, it will keep good for any length of time. Absinthe Cocktail. Use Mixing Glass. THREE dashes [Angostura bitters](#), three VI" dashes syrup; one pony absinthe. Fill with ice, mix well, and strain into a cocktail glass. Armour Cocktail. Use Mixing Glass. THREE d...

### Gin Cocktail—Tom.

*Use Mixing Glass.*

THREE dashes [Angostura bitters](#); one small lump sugar; one portion Tom gin. Fill with ice, mix, and strain into a cocktail glass.

### Gin Cocktail—Old-fashioned Tom.

MAKE the same as an Old-fashioned Holland Gin Cocktail, using Tom in the place of Holland gin.

### Harvard Cocktail.

*Use Mixing Glass.*

ONE dash syrup; three dashes [Angostura bitters](#); one-half Italian vermouth; one-half brandy. Fill with ice, mix, and strain into a cocktail glass, then fill with seltzer and serve quickly.





# What does this all mean for a digital National Collection?

**Assumption:** IIF is the means by which National Collection objects are distributed to user interfaces

- Which means contributors have to provide it
- Some of this activity HAS to be specific to the publisher - it's their stuff, they have to arrange and describe it, link it to sensible descriptive metadata
- *Some* of it can use common tools, services, platforms, libraries

## Big IIIF costs money

- Institutions that have large digital workflows already can add bespoke and appropriate IIIF creation to those workflows.
- Organisations and individuals with a handful of objects can create manifests by hand, host them on GitHub.
- What's the answer for orgs with a few hundred or a few tens of thousands of things?

III F is only an answer to part of it

- Deep-zoom is nice, but...

III F is only an answer to part of it

- Deep-zoom is nice, but
- Having Manifests is more important than having deep-zoom, but...

IIIF is only an answer to part of it

- Deep-zoom is nice, but
- Having Manifests is more important than having deep-zoom, but
- Having Manifests is no good if a National Collection has no means of discovering them, and...

IIIF is only an answer to part of it

- Deep-zoom is nice, but
- Having Manifests is more important than having deep-zoom, but
- Having Manifests is no good if a National Collection has no means of discovering them, and
- A National Collection can't do much with those Manifests without a scheme to organise them by, and...

## IIIF is only an answer to part of it

- Deep-zoom is nice, but
- Having Manifests is more important than having deep-zoom, but
- Having Manifests is no good if a National Collection has no means of discovering them, and
- A National Collection can't do much with those Manifests without a scheme to organise them by, and
- It's no good to humans without a lot of user research and design, some of which informs what that scheme, or schemes, might be

# Thank you!

These slides: [bit.ly/tanc-tc2](https://bit.ly/tanc-tc2)

Tom Crane

Technology Director, Digirati  
[cultural-heritage.digirati.com](https://cultural-heritage.digirati.com)

[@tomofhernehill](#)

A bit more reading on the IIF Universe

[Beyond the Viewer: fragments and links in annotation space](#)