

EMPIR 17NRM03 EUCoM
Seminar 29.06.2021, online

Application and results

Session 3

Josef Frese, Ulrich Neuschaefer-Rube, Markus Bartscher
Department 5.3 Coordinate Metrology
Working Group 5.34 “Multisensor Coordinate Metrology”

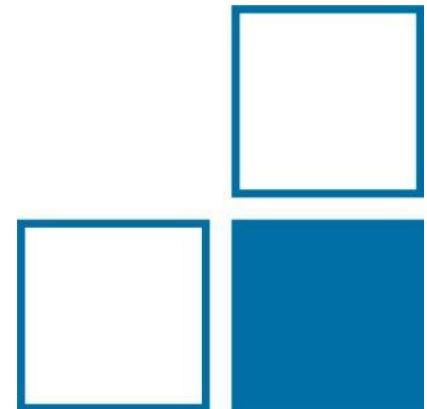

- **Part 1: Round Robin**
 - Scope of the validation study

- **Part 2: Reference standards & Measurements**
 - Selection criteria
 - Reference standards
 - Measurement strategies

- **Part 3: Implementing the new methods**
 - Software tools to calculate EUCoM measurement uncertainties

- **Part 4: Results**

- **Conclusion & Outlook**

Part 1: Round Robin



- **OBJECTIVE:**
 - Collect many and diverse datasets for method validation

- **Some constraints**
 - Each participant had to measure at least...
 - 1 **prismatic** standard
 - 1 **freeform** standard

- **Not a traditional round robin**
 - Not about the best possible measurement / low uncertainty
 - Instead: Different uncertainties or measurement “qualities”
 - Calibration / reference data was provided by consortium members
 - All data was shared openly

■ Participants

- 14 partners
 - Different labs
 - Different CMMs (with different accuracy)

■ Unexpected hurdles

- Brexit
 - Added a “surprise” customs border
- COVID-19 pandemic
 - Lock-downs restricting lab access and slowing work



Original source: Wikimedia commons

Outcome

- Collected 30+ complete datasets
- More than originally planned
- Every partner was able to contribute at least one dataset
- Archived data will be made available after the project

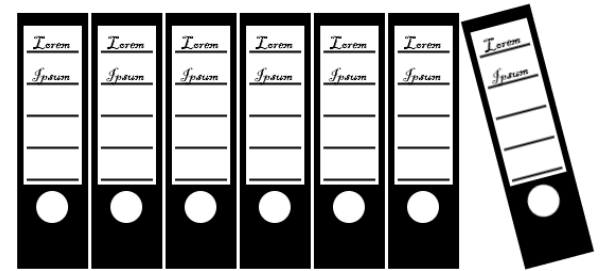

A “complete” partner dataset comprises:

- Five repeat measurements
- Measurement in four orientations (for method A)
- Sphere and gauge block measurement (for method A)
- Point clouds and vectors (for method B)

→ This equates to hundreds of measurements

→ Lots of raw data available for EUCoM and future research

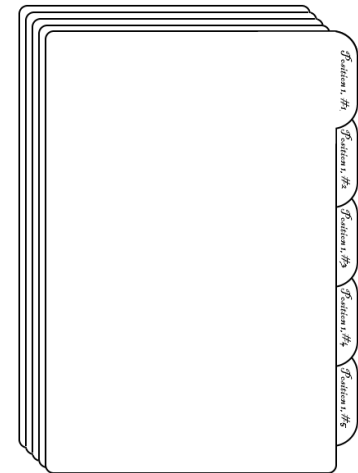

Part 2: Reference standards & Measurements

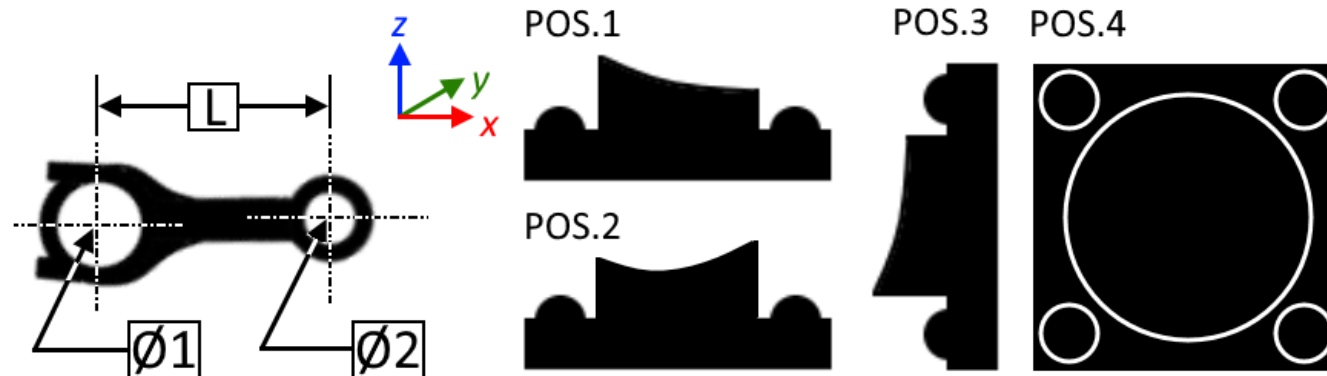

- **PROJECT REQUIREMENT:**
 - One prismatic and one freeform reference standard

- **Additional requirements (defined during the selection process):**
 - Size range: 100 - 500 mm (~300 mm)
 - Use a larger CMM volume to magnify uncertainties (e.g. positioning)

 - At least five different measurand types
 - General method demonstration
 - Representative sample of “common” measurands

 - At least some industrial workpieces
 - Avoid using only “research artefacts”
 - EUCoM is intended for industry application

■ An aside about the artefact types

■ Prismatic artefacts:

- Based on standard geometries
 - Spheres, cylinders, planes ...
- Easy to describe
 - Simple mathematical models
 - Usually just a few parameters
- Geometries and measurands are well-defined (including normals)
 - Diameter, parallelism, ...

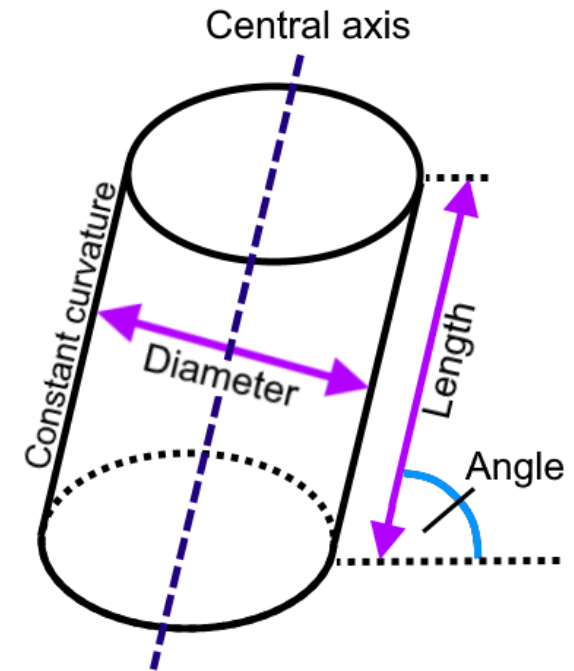

Freeforms artefacts

- No standard models for freeforms/sculptured surfaces
- Description by model approximations
 - E.g. splines, rarely a parameterised equation ($f(x,y,z)$)
 - Parameters are hard to define
 - Models are often limited to a small region of a surface
- “Complete” measurement requires high point density
 - Reliance on prior knowledge (e.g. normals)
 - Result may be affected by quality of prior knowledge
- Evaluation is less straight-forward
 - E.g. comparing profiles or points
 - Feature-based registration becomes more difficult
 - Much easier to register based on simple features like spheres, flat planes

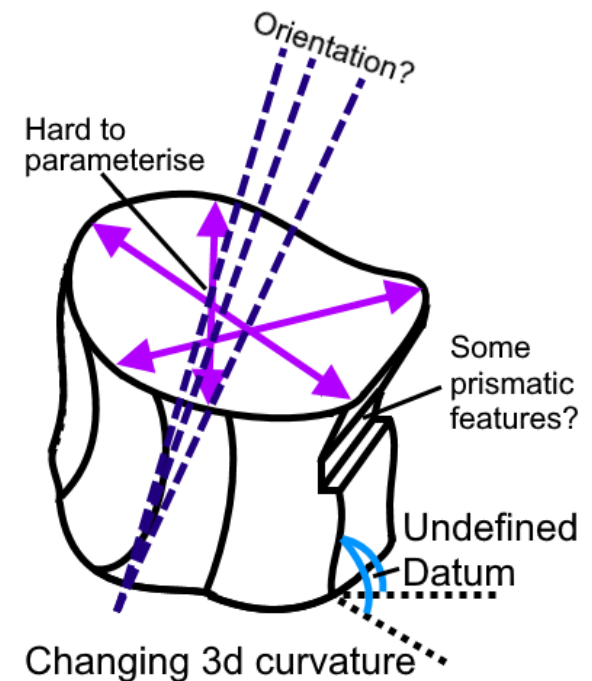

■ Why is this distinction important?

- Freeforms have a number of advantages over prismatic designs:
 - Enable more compact or efficient designs, e.g. merging several functions in one part
 - Relevant to manufacturing industries, e.g. automotive, medical, optics



■ Evaluation strategies for freeforms can be very different

- Need to demonstrate that EUCoM methods also work for freeforms
- Can't be limited to prismatic

■ Six reference standards were selected

- 3x prismatic
- 3x freeform
- Broad range of measurands
- Greatly improved flexibility in planning during the pandemic

■ Pandemic problems

- The first lockdown hit towards the end of the calibration phase
- Some reference standards became inaccessible
- Calibrations and / or measurements couldn't be completed



Multi-feature check (MFC)

- Designed as reference standard for CMMs
- 50 features, 19 measurand types to choose from
→ Plenty of variety
- Two specimens were circulated
- One was of “lower quality” due to age and wear

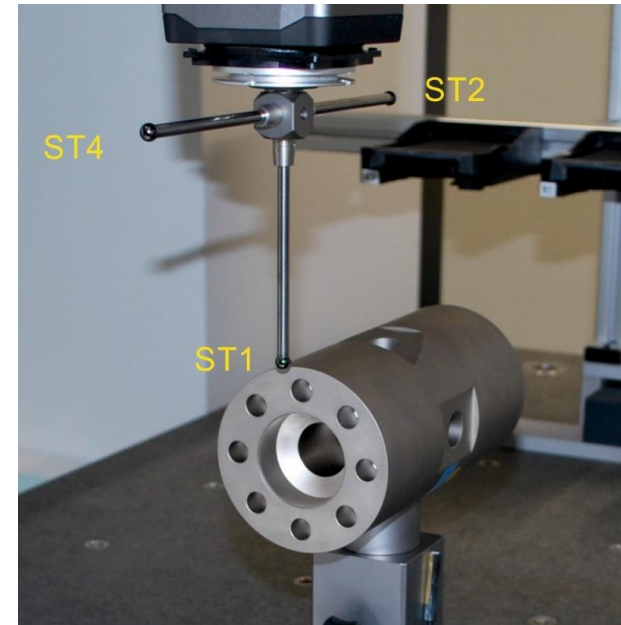

*Multi-feature check
(200 x 100 mm l x d)*

Measurands:

- Selected features to cover form, dimensions and positioning
- 17 measurements chosen
- Wanted to avoid overloading this standard with too many tasks

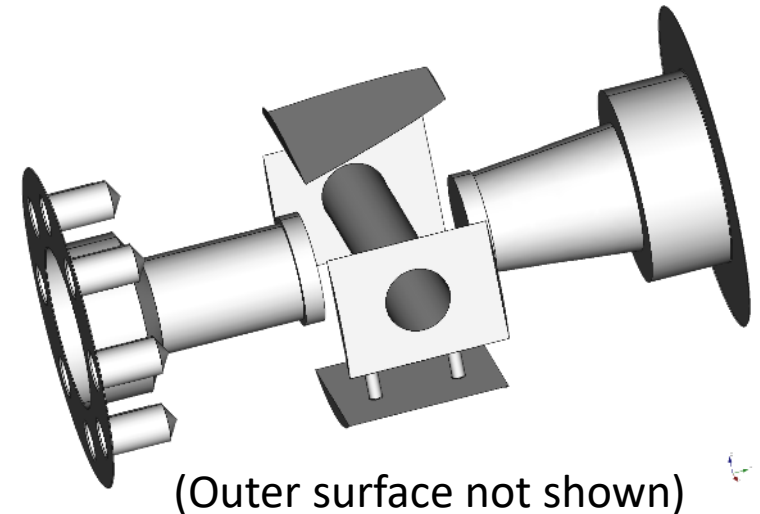
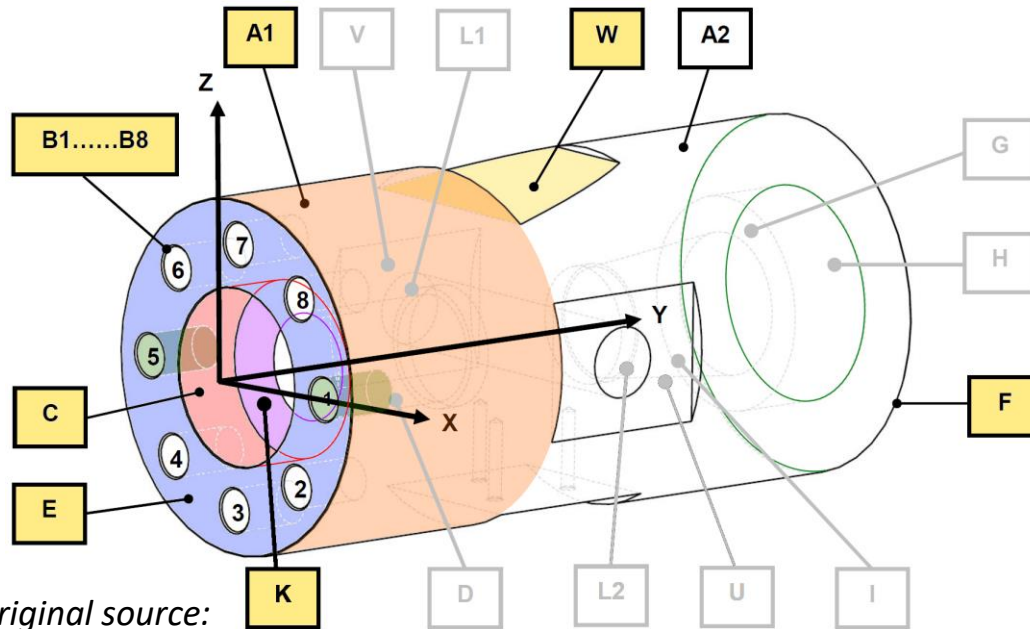

Original source:
eumetron

Name	Geometry	Measurands
A1	External cylinder	surface straightness, roundness, cylindricity, diameter
B1, B5	Two internal cylinders	distance between holes
C	Internal cylinder	diameter and form, perpendicularity to E, concentricity, radial and total radial runout to A1
E, F	Two planes	flatness, distance, parallelism
K	Internal cone	diameter, cone angle, parallelism to A2
W	Inclined plane	Angularity to A1

■ Connecting rod

- Manufactured part
- Chosen for its simplicity
- Measurands
 - Cylinders, diameters and distance
 - Parallelism between cylinder axes
 - Orthogonality of cylinders to plane 1

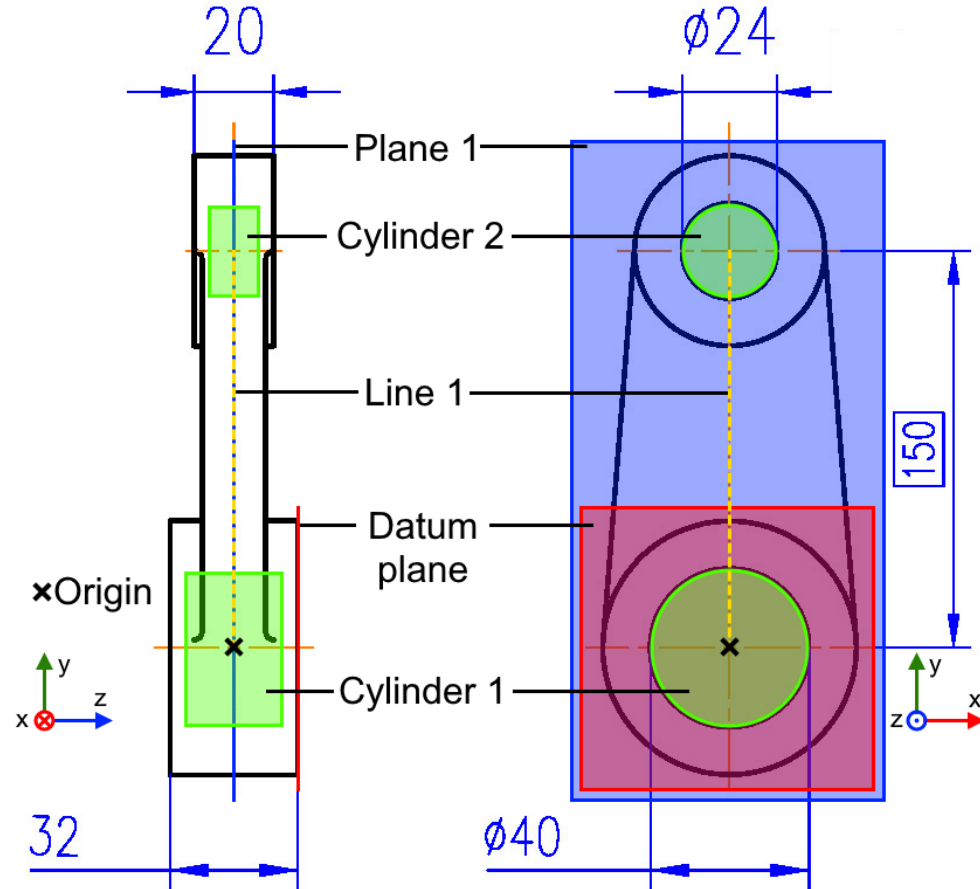

Source: CMI

Hyperbolic Paraboloid

- Freeform test object for CMMs
- Includes reference spheres for registration
- Mathematically defined freeform surface
- Surface is sampled in a regular grid (52 points)
- Point by point comparison

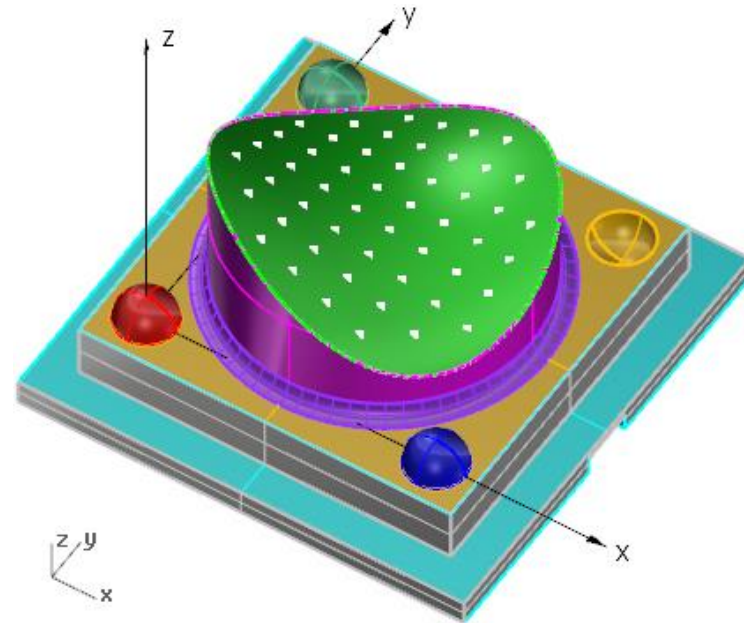
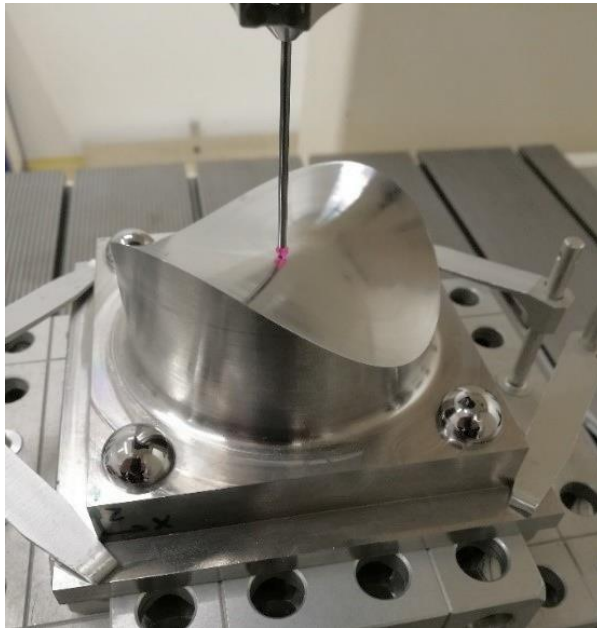

Hyperbolic paraboloid (100x100x60 mm) Source: CMI

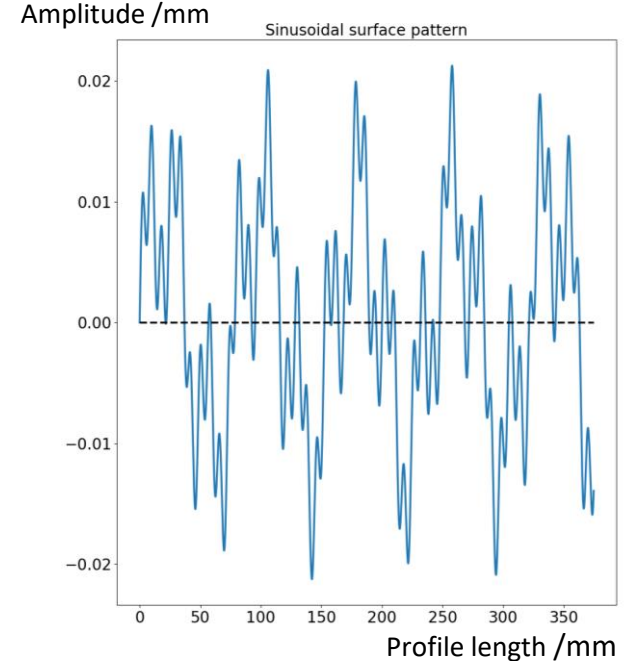
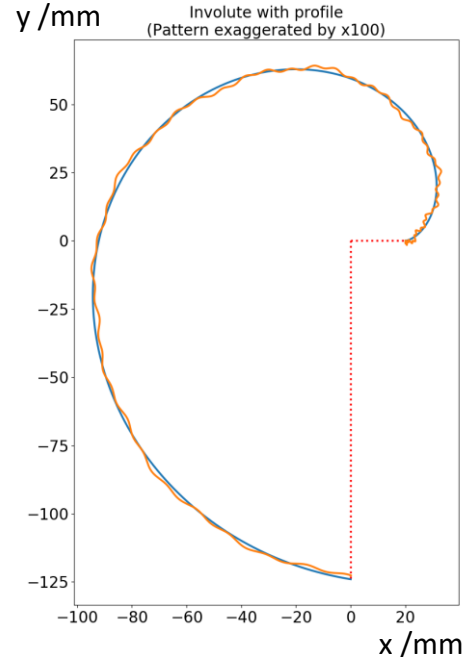

■ Involute gear

- Gear measurement test object repurposed as a “simple” 1d freeform
- Two versions:
 - Smooth involute
 - Involute with superimposed sinusoid

Part 3: Implementing the new methods

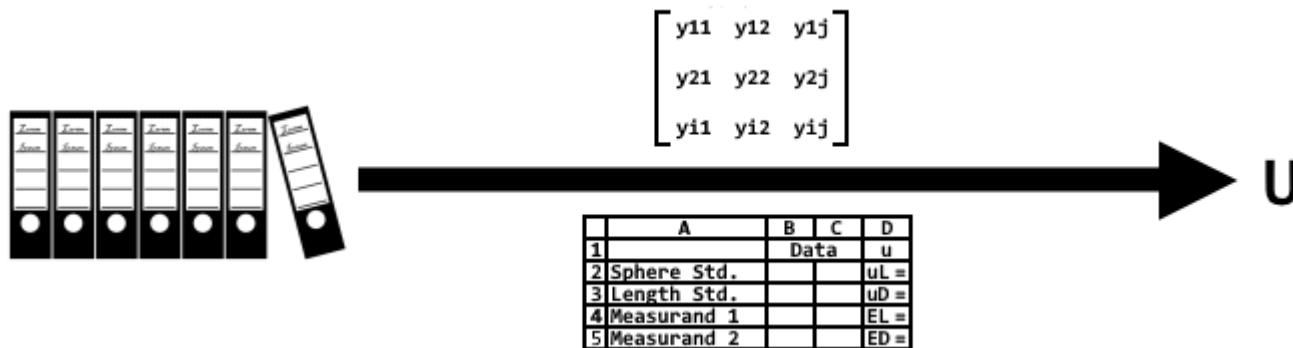

- **Tool creation**
 - One template for each reference standard
 - Object-specific
 - Designed and tested by one participant
 - Same templates used by all participants

- **Tool sharing**
 - Avoids inconsistencies from implementation differences
 - Numerical differences between software kits
 - Programming errors and other human factors

 - Tools are designed for more accessibility
 - Understandable not just to the developer
 - Every consortium member needs to be able to use it

 - Common data input and results formats

- **Excel spreadsheets (.xlsx)**
 - Data is pasted into the correct cells
 - Length and sphere standards
 - Repeat run and orientation results
 - Some additional settings controlled by cell entry
 - e.g., coverage factor, stylus type
 - Results displayed in the spreadsheet

- **Prime developer: CMI**
 - Includes a “manual” page
 - No expensive software licenses required
 - Very accessible to casual users
 - Easy to modify and adapt to new workpieces

Measurement data

Reference data

U_A

$E_{N,R}$

CONNECTING ROD MEASUREMENT																										
Coverage factor k	2	Cycle 1				Cycle 2				Cycle 3				Cycle 4				Cycle 5				Measurement value	Expanded combined standard uncertainty	Calibrated value	Uncertainty of calibrated value	En number
Measured feature		11 y	12 y	13 y	14 y	21 y	22 y	23 y	24 y	31 y	32 y	33 y	34 y	41 y	42 y	43 y	44 y	51 y	52 y	53 y	54 y	y	U	y ref	U ref	En
Circle 3 diameter	2.5.1	50.6079	50.6090	50.6082	50.6079	50.6080	50.6089	50.6082	50.6079	50.6079	50.6090	50.6083	50.6079	50.6079	50.6090	50.6083	50.6079	50.6079	50.6090	50.6083	50.6079	50.608 26	0.001 42	50.607 21	0.000 55	0.69
Circle 4 diameter	2.5.1	19.0152	19.0165	19.0153	19.0152	19.0152	19.0164	19.0153	19.0153	19.0153	19.0165	19.0152	19.0152	19.0152	19.0164	19.0153	19.0153	19.0153	19.0164	19.0152	19.0152	19.015 54	0.001 46	19.015 38	0.000 52	0.11
Centre 3 - Centre 4 distance	2.5.2	140.0067	140.0061	140.0068	140.0064	140.0068	140.0062	140.0068	140.0064	140.0068	140.0062	140.0066	140.0063	140.0066	140.0061	140.0066	140.0063	140.0066	140.0063	140.0066	140.0062	140.006 46	0.001 32	140.006 42	0.000 64	0.03
Axis 1 - Axis 2 parallelism	2.5.3	0.0055	0.0055	0.0056	0.0057	0.0055	0.0056	0.0056	0.0057	0.0055	0.0056	0.0055	0.0055	0.0055	0.0055	0.0055	0.0055	0.0055	0.0055	0.0055	0.0057	0.005 56	0.001 30	0.001 79	0.000 70	2.55
Cylinder 1 diameter	2.5.4	50.6127	50.6128	50.6121	50.6131	50.6126	50.6129	50.6124	50.6128	50.6126	50.6129	50.6124	50.6131	50.6125	50.6130	50.6123	50.6132	50.6126	50.6129	50.6125	50.6129	50.612 71	0.001 37	50.611 33	0.000 65	0.91
Cylinder 2 diameter	2.5.4	19.0284	19.0292	19.0280	19.0290	19.0285	19.0291	19.0279	19.0288	19.0285	19.0291	19.0278	19.0290	19.0284	19.0290	19.0278	19.0286	19.0286	19.0290	19.0277	19.0288	19.028 56	0.001 44	19.025 22	0.000 62	2.14

$$U = k \sqrt{E_L^2 + E_D^2 + E_{D,Loc}^2 + \frac{u_{rep}^2}{n_1} + \frac{u_{geo}^2}{n_2} + u_L^2 + u_D^2 + u_{D,Loc}^2}$$

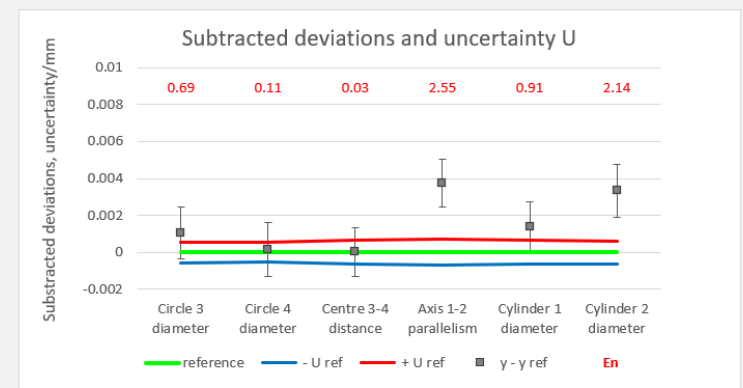
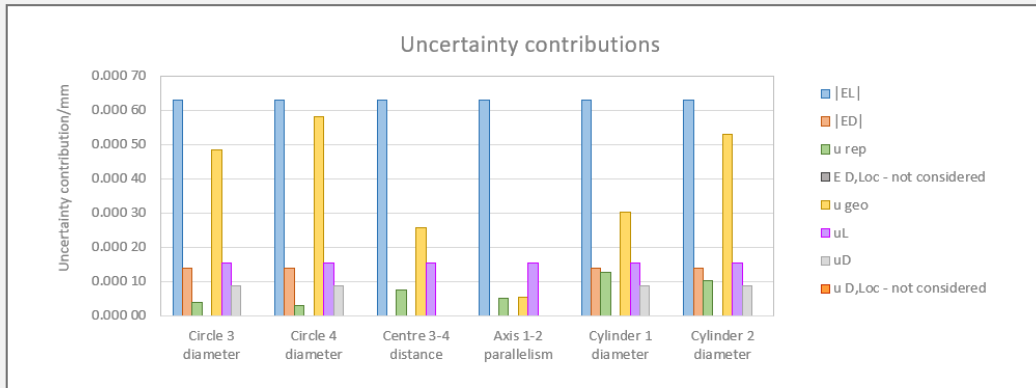

Data input and results in the connecting rod template

■ MatLab scripts

- Uses input templates similar to Method A workbooks
 - measured values
 - point clouds
 - vectors

■ Prime developer: NPL

- Uses MatLab due to matrix operations needed for evaluation
- Adept users can adapt the code
 - E.g. translation into other languages

- **Tools will be publicly available**

- **The original data will also be available**

- **ERGO:**

- **Users can adapt existing templates to new workpieces**
 - Easiest way to try out these methods
 - Build a template for your workpiece and compare to it other uncertainty estimates

- **Users can develop their own software**
 - Use the original tools and data as a reference
 - Compare your own results obtained from the same data
 - Validate your implementation

Part 4: Results

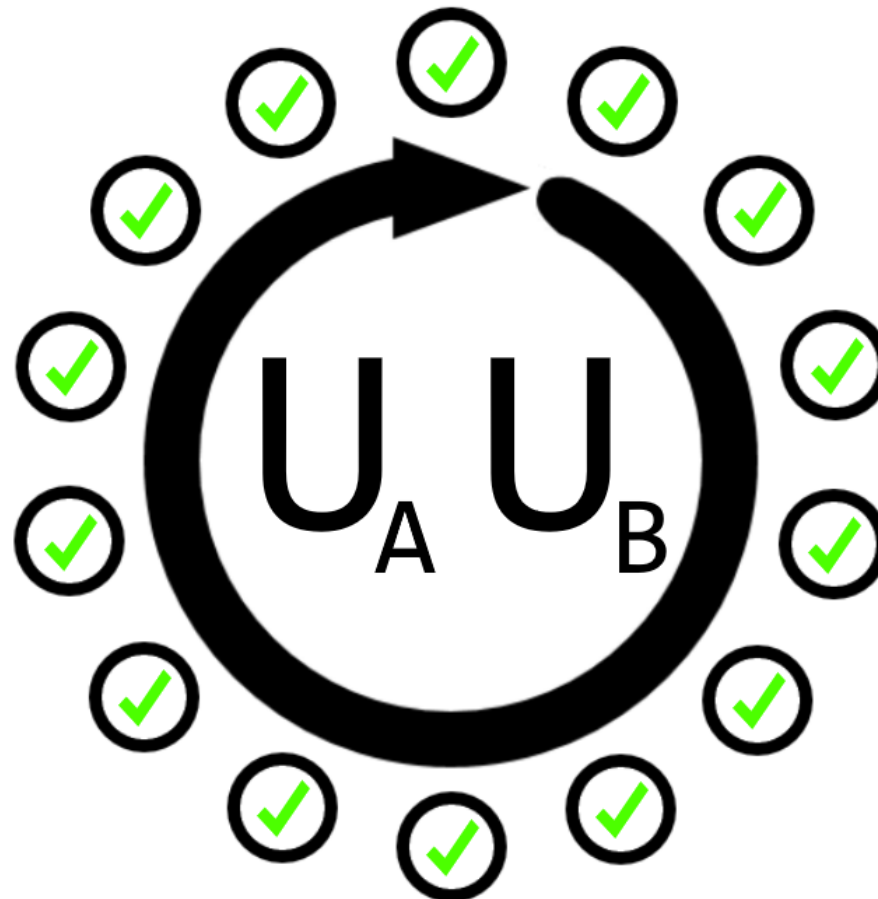

- **All data sets were evaluated**
 - Results were collected and compared
 - In parts this is still on-going

- **Evaluated data:**
 - EUCoM method uncertainties U_A, U_B
 - Reference uncertainty U_{ref}
 - Reference uncertainty was based on established methods
 - Reference methods selected by the partners responsible for calibration

■ Use of proficiency testing for comparisons:

- Normalised Error (ISO 17043)

$$E_N = \left| \frac{x_{meas} - x_{ref}}{\sqrt{U_{meas}^2 + U_{ref}^2}} \right|$$

- Pass-criterion: $E_N \leq 1$
- Calculated for each measurand separately

■ Limitations:

- Can't be used to spot overestimated U values
- Measured values must be independent
- Compared uncertainties must use the same confidence level
 - E.g. $k = 2$ or confidence-level 95%

Comparison to the reference value

- $E_{N,R}$
calculated with either U_A or U_B and U_{ref}
- Check conformity of EUCoM uncertainties with other methods

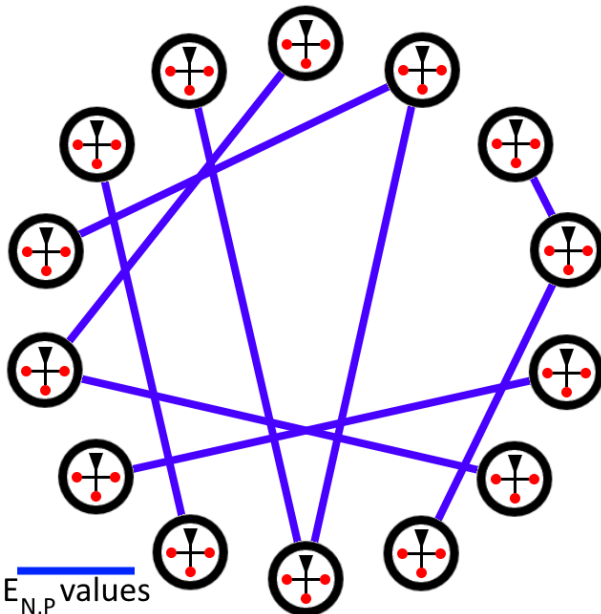
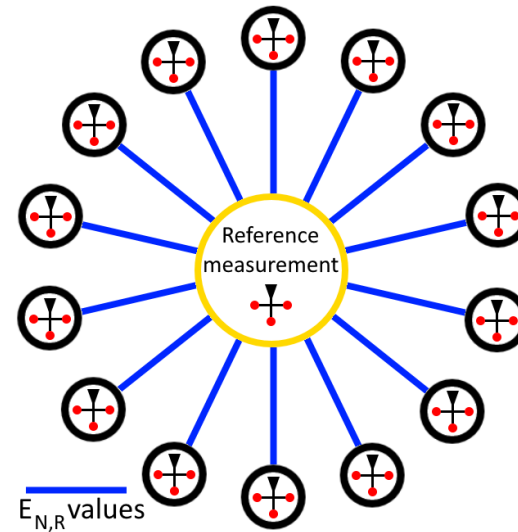

Comparison of paired values

- $E_{N,P}$
- Pair up measurements and test them against each other
- In effect: each partner provides reference values for the next
- Check internal consistency of uncertainties – Method self-test

- **Method A vs. Method B**
 - Check whether the two estimates agree

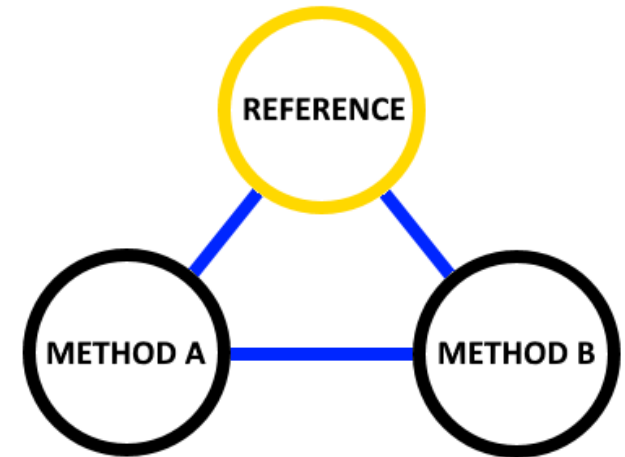

■ Connecting rod, method A

- Noteworthy:
- No obvious inconsistencies of U_A within each partner measurement
- No obvious inconsistencies across the board
- Some U_A are similar to U_{ref} (from VCMM)



Method A Expanded measurement uncertainties

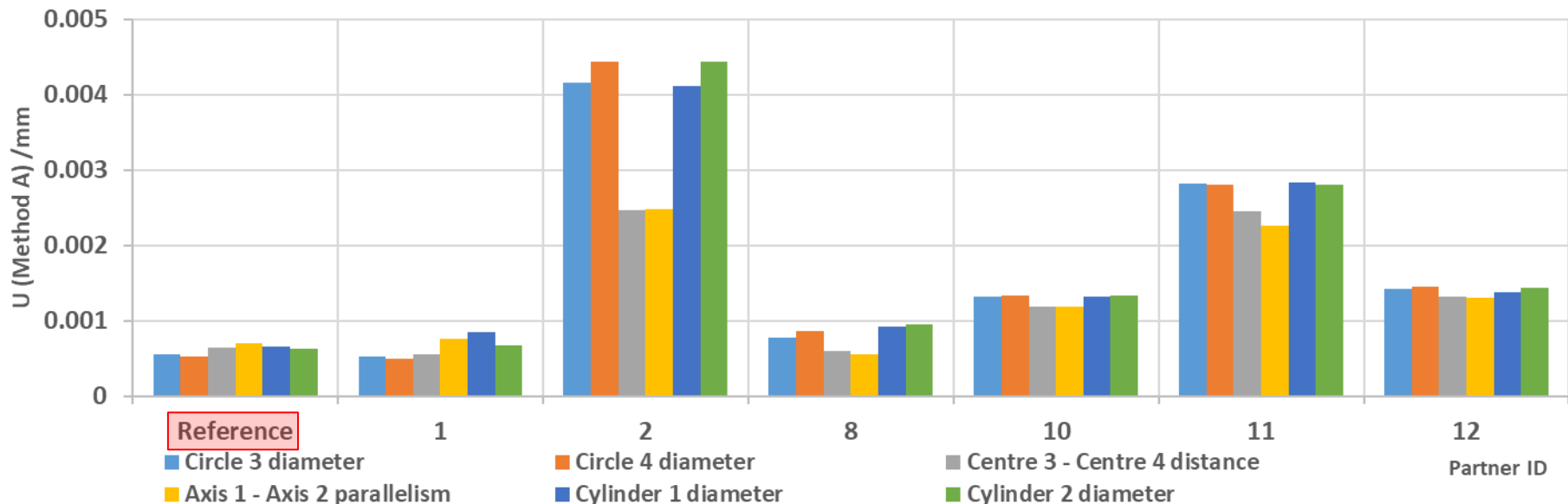

Connecting rod, method A

- Same data, looking at features
- Differences between measurements more visible – “Low quality” measurements were planned for
- Also some very good results compared to U_{ref}



Method A Expanded measurement uncertainties

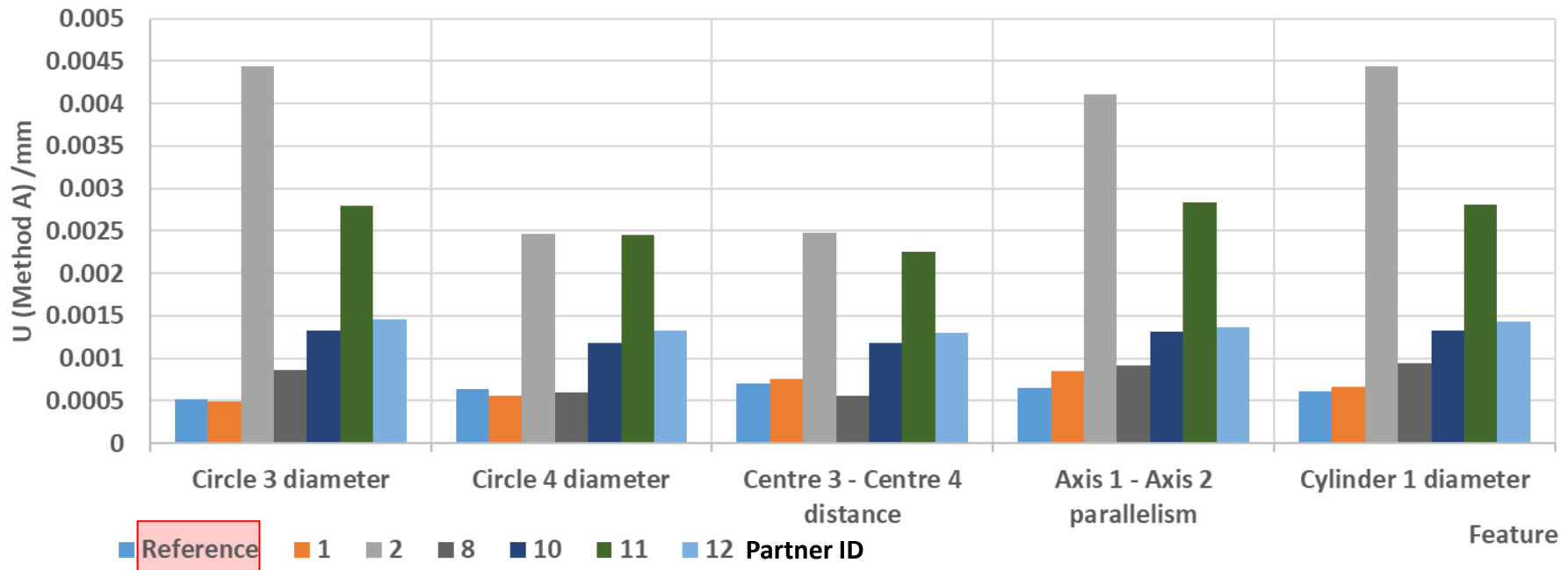

Connecting rod, method A

- Normalised error based on the reference
- Roughly half the population exceeds maximum



Method A, $E_{N,R}$

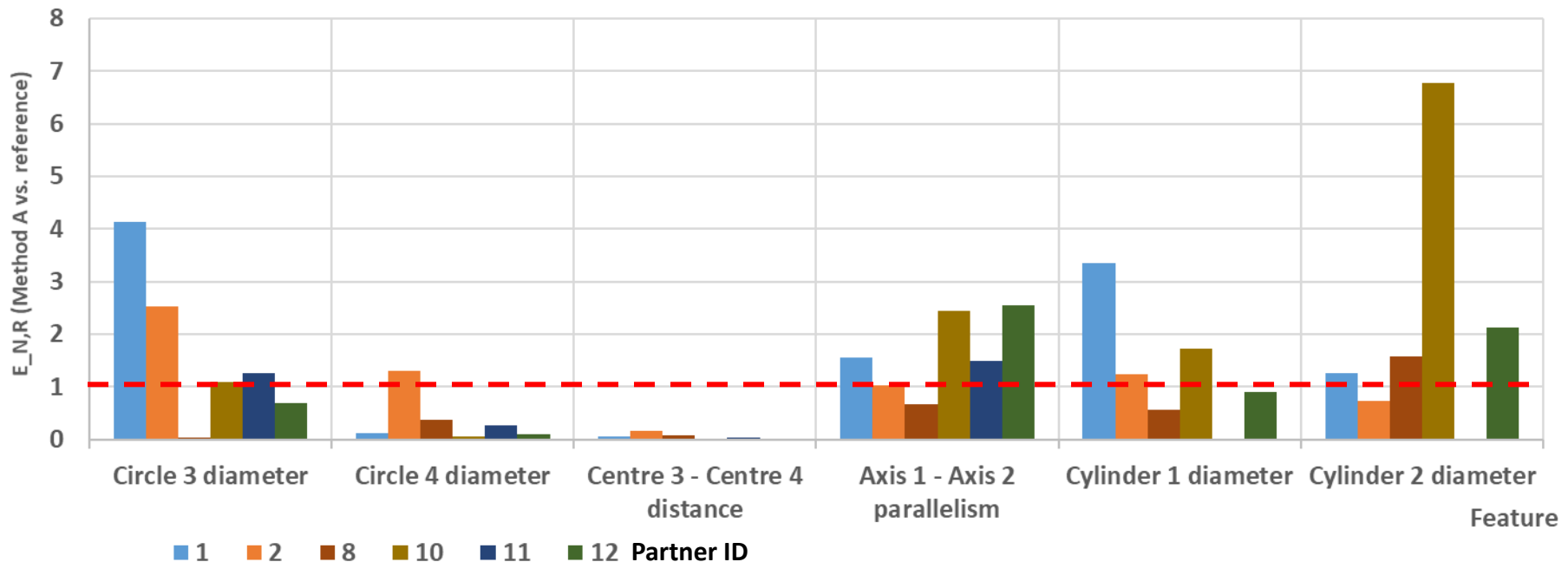

■ Connecting rod, method A

- Normalised error based on the reference
- Again several limit violations
 - Possible issue with the artefact along the route
 - Reference re-verification or further analysis needed
 - Otherwise issue with Method A



Method A, E_{N,P}

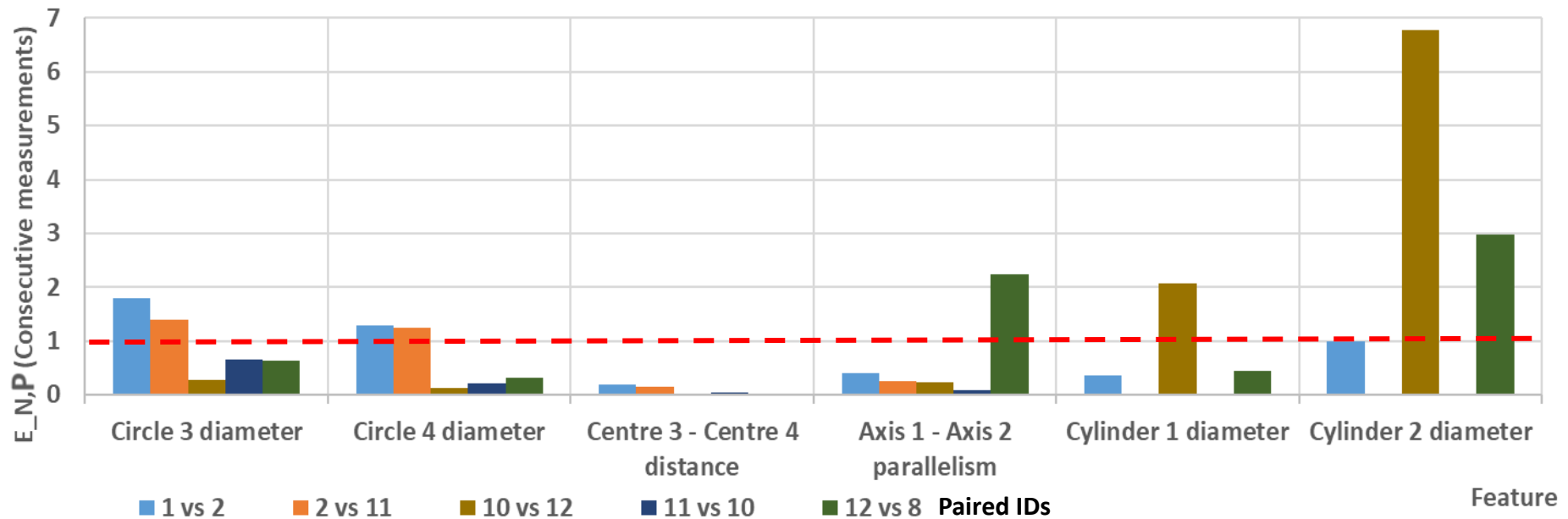

Hyperbolic paraboloid, method A

- Illustrates method A
 - Variability of U_A
 - Dominant contribution u_{geo} (probe)
- U_A is the result of processing a lot of real measurement data
- U_{ref} is a “traditional” estimate
 - Uses U_{max} for all points, hence constant



Method A Expanded measurement uncertainties

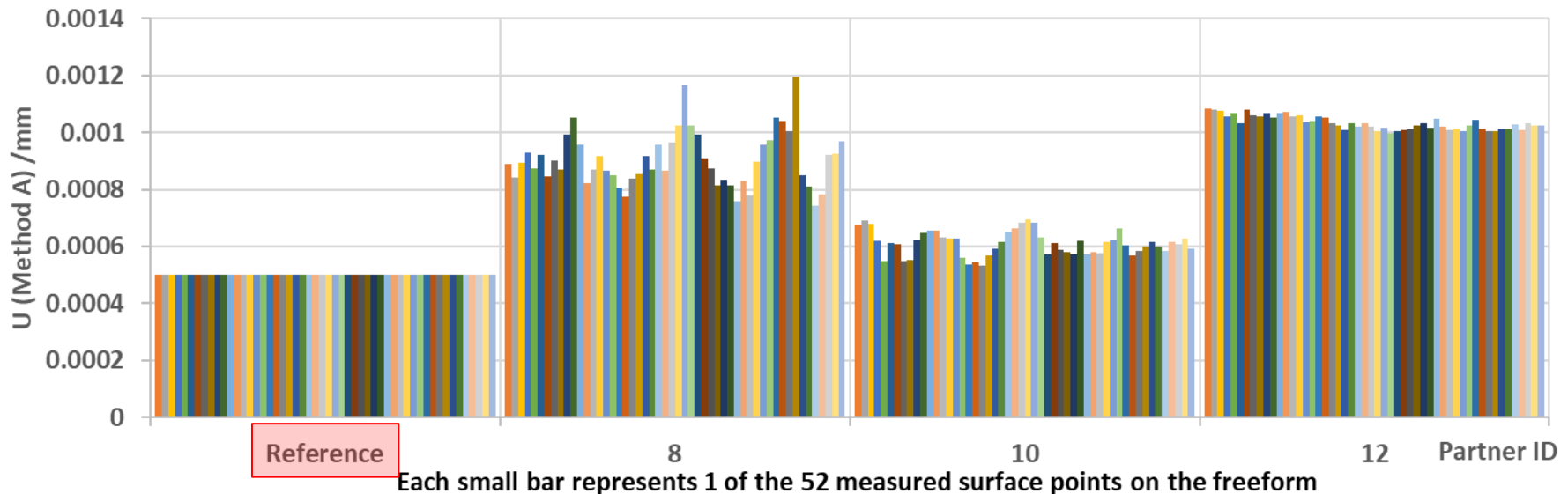

Hyperbolic paraboloid, method A

- Preliminary result
 - Probable evaluation error in one data set (excluded from E_N chart)
 - Doesn't affect U_A s
- Otherwise low E_N s, few violations
 - 2 / 104 values
 - Promising outcome (VCMC requires 95% agreement)

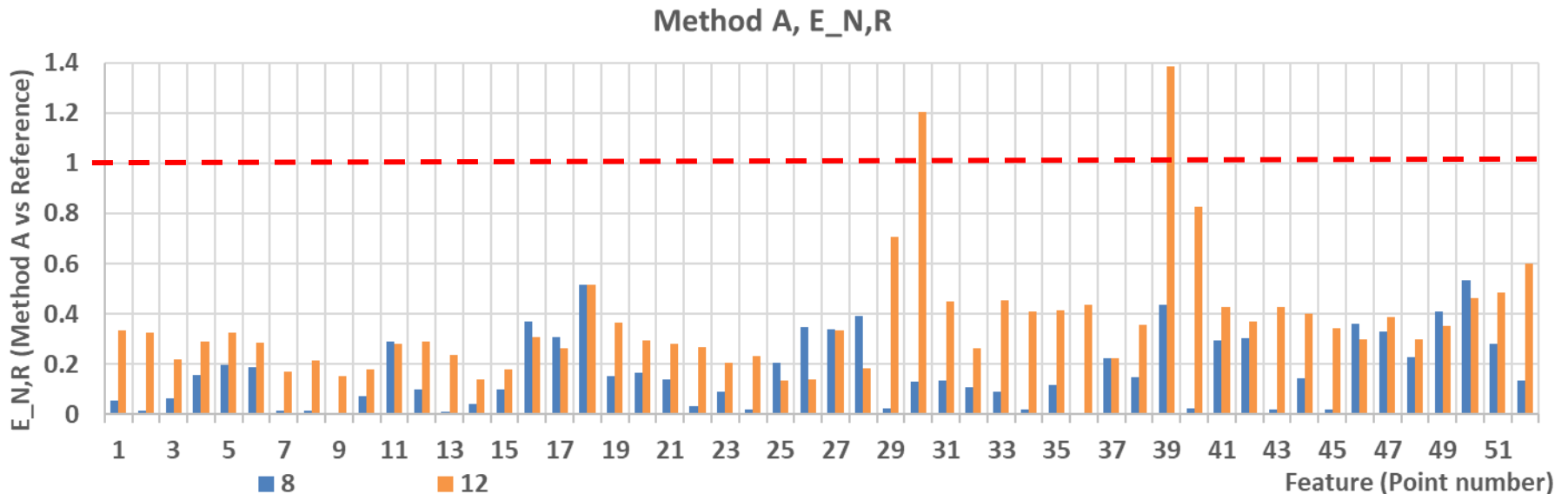

- **Method A results are ambiguous**
 - Can't say for certain whether it **does** or **does not** work, yet

- **In favour:**
 - Consistent U_A
 - U_A s don't vary greatly within a single measurement
 - Little or no dependency on the feature being considered
 - Differences between measurements are to expected
 - As conditions change, so does U
 - Hardware, environment, ...
 - Comparable uncertainties
 - By itself, U_A often agrees reasonably well with U_{ref}

- **Against:**
 - Proficiency testing says “no” ...
 - A significant fraction of measurements fail the test
 - Not necessarily due to method A but it's hard to tell

- **EUCoM has created a generous data trove**
 - Different artefacts and measurands

- **EUCoM will provide the tools to apply the new uncertainty estimates**
 - The templates are a good starting point for customised software

- **Method validation still on-going/pending**

- **Method A is a practical approach to measurement uncertainty**
 - Feed it with a lot of measurement data to get an estimate
 - Avoids modelling and best-guess values
 - Modelling can be difficult
 - Some assumptions might be “uncomfortable”

- **Results are still being added to the evaluation**
- **An analysis of method B will be added**

- **Intercomparison between new methods**
 - Method A vs. method B
- **Meta-analyses**
 - Usefulness of different orientations (Method A)
 - Identify key uncertainty contributors (u_{rep} , ...)
 - Correlating method A results with CMM “accuracy” where possible

- **All tools and data will be made public**
 - Anonymous data (of course)
 - Ideal conditions for you to try out these methods yourself

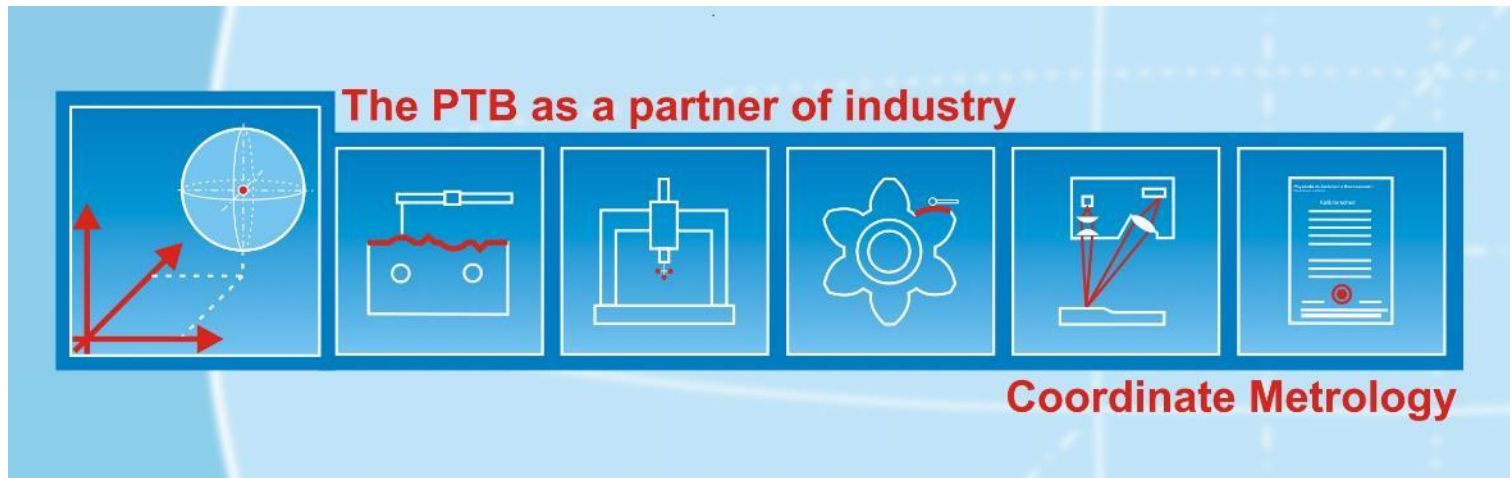

Thank you for your attention!



U. Neuschaefer-Rube, M. Bartscher, J. Frese
Physikalisch-Technische Bundesanstalt
Coordinate Metrology Department
Multisensor-Coordinate Metrology



Tel.: +49 531 592-5311

E-Mail: ulrich.neuschaefer-rube@ptb.de

Web: www.ptb.de/cms/en/ptb/fachabteilungen/abt5/fb-53/ag-534.html



The EMPIR initiative is co-funded by the European Union's Horizon 2020 research and innovation programme and the EMPIR Participating States

This project has received funding from the EMPIR programme co-financed by the Participating States and from the European Union's Horizon 2020 research and innovation programme.