

LMU • Institut für Vorderasiatische Archäologie • Elisa Roßberger



eHeritage 11/2020 – 10/2023

# Bilder neu verknoten. Building an “Annotated Corpus of Ancient West Asian Imagery: Cylinder Seals” (ACAWAI-CS)

Elisa Roßberger (Vorderasiatische Archäologie),  
Anna Kurmangaliev (Vorderasiatische Archäologie), Nathan Morello (Assyriologie),  
Hanieh Arjomand-Fard (IT), Matan Atad (Machine Learning/AI)

Anna Schellkopf (Archäologie), Elena Sher (Alter Orient)

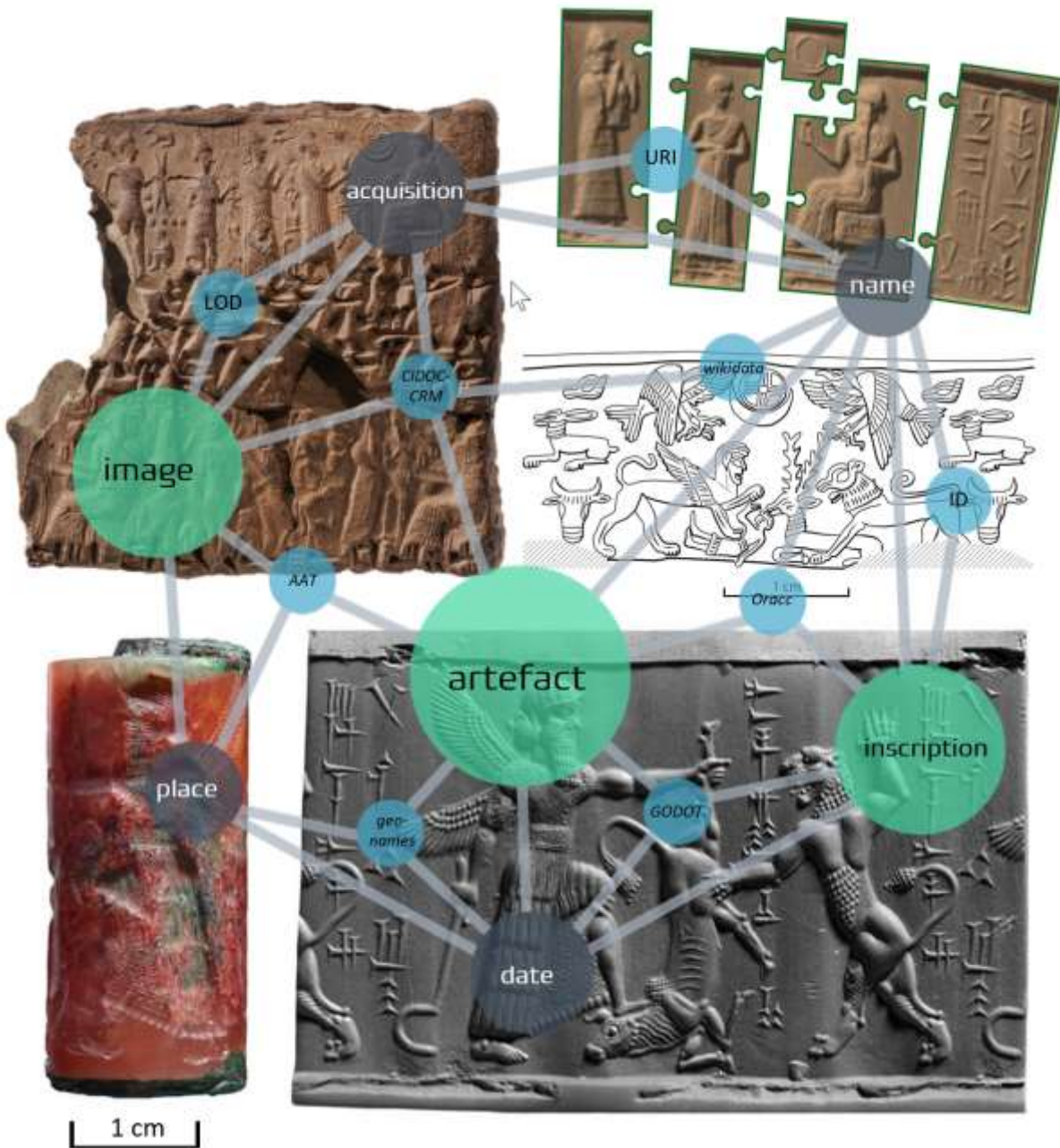

**FAIR** Data Principles (**F**indable, **A**ccessible, **I**nteroperable, **R**eusable)

**Linked Open Data**  
(unique identifier, norm data, RDF, SPARQL, controlled vocabularies)

**Semantic Web**, Knowledge Graph

Seals connected **people**, **things** and **places**.

Their use created a **dense network** of personal/corporate identities and liabilities.

The challenge of **multimodality!**

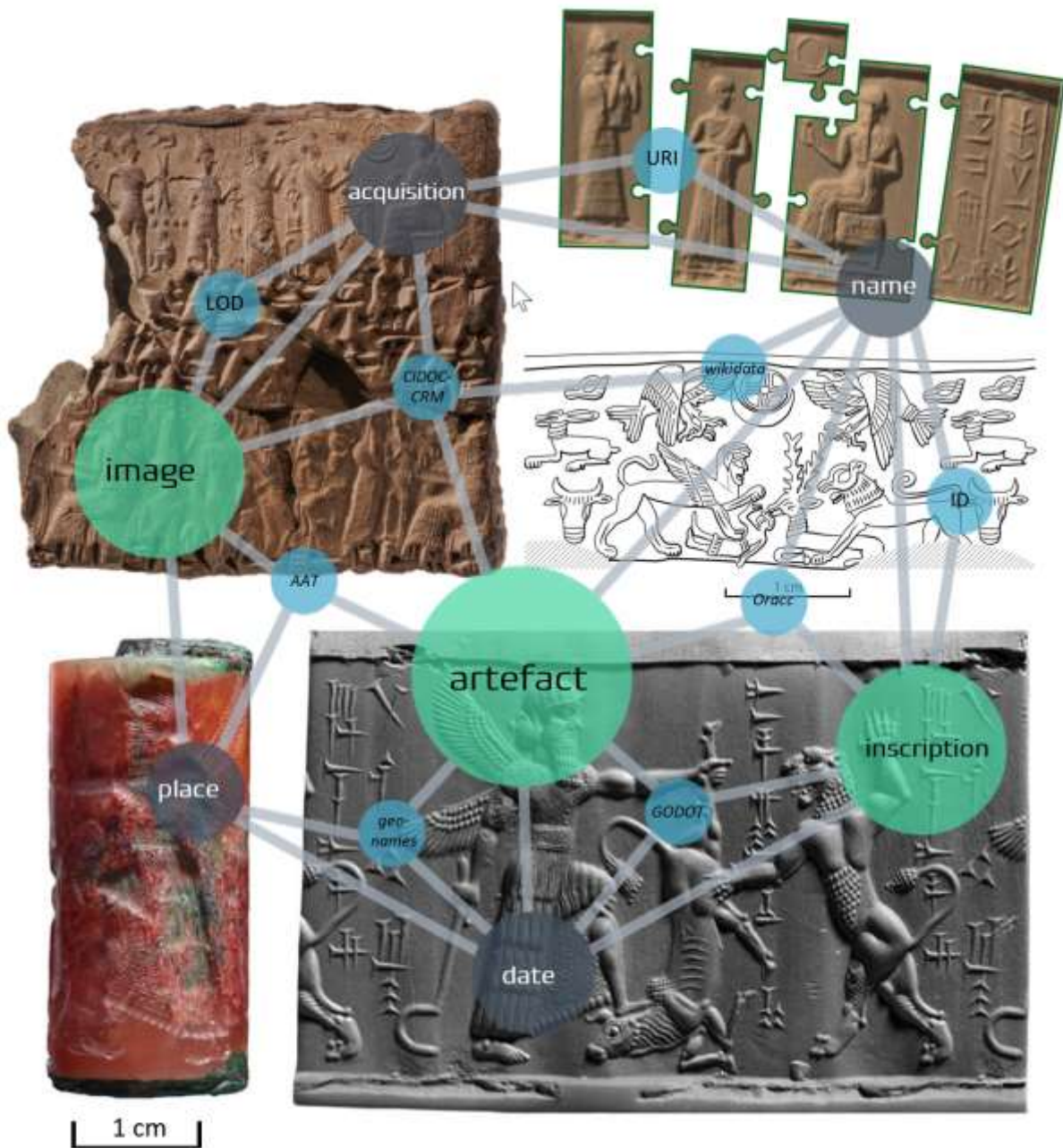

**Collaborative work**  
**interdisciplinary team**  
 no final product

IT-Gruppe Geisteswissenschaften

NFDI4culture

AK Digitale Kunstgeschichte



Tel Shimron (Middle Bronze Age II)

1 cm



Tablet in envelope (Ur III)



Envelope from Iščali and sealed tablet from Ur (Old Babylonian), sealing (Ur-III)

# Disparity of knowledge



550 129509



551 108785



553 132531



554 89713



555 21210



557 129524



558 89432

553. BM 132531 (1959.4.11, 2)

A god in a flouced robe, with his hair in a fish-tail, with hands clasped, faces the god with extended arm who wears a flouced robe; the king with a mace faces the suppliant goddess before whom are a hedgehog above a goat which sits up on its haunches and looks back over its shoulder towards the left.

x- <sup>du</sup> ?	... dunum,
dumu ir- <sup>d</sup> suen	son of Warad-Sin,
ir- <sup>d</sup> ne-eri <sub>11</sub> -gal	servant of Nergal.

Line 1 : the first sign has been obscured by a human head cut over it (proportionately larger than the other heads on the seal); the second sign <sup>du</sup>, is inscribed in reverse; the third sign <sup>nu</sup> is cut over an erasure and has been recut as a fly.

Haematite; chipped. 2.5 x 1.2 cm.

Miss M.R.F. Ready Bequest.

554. BM 89713 (25.5.3, R.169)

The god with extended arm, wearing a flouced robe, faces a robed god(?) with one hand raised, with a star between them; a deity in a flouced robe, with hands clasped, faces a god in a flouced robe. There is a line border round the bottom of the seal.

Haematite; chipped. 1.8 x 0.7 cm.

Rich Collection.

Cullimore, no. 130.

Collon 1986, 197

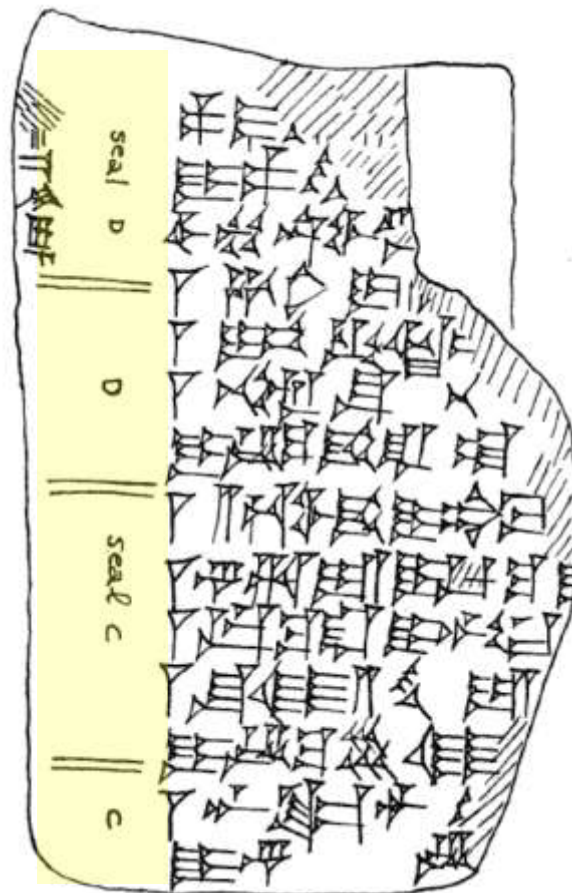

Greengus 1979, pl. XIX no. 35

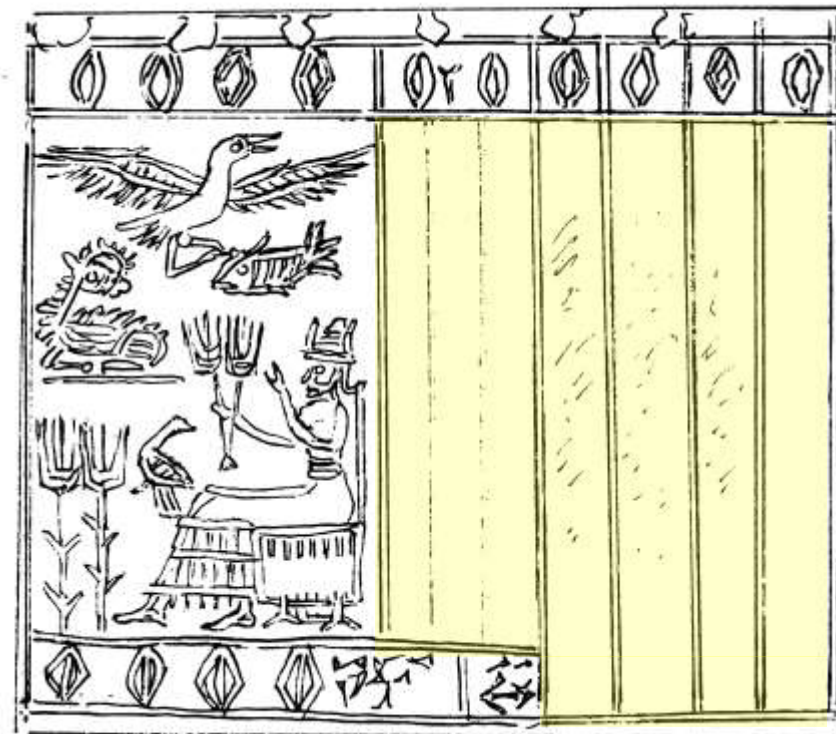

Stiehler-Alegria Delgado 1996, Nr. 175

# ACAWAI-CS Corpus

**DigANES 2017–2018**  
5.400 seals (physical/virtual)  
2.200 sealed artefacts  
14.000 picture elements

**since 11/2020**  
+ 1.000 seals  
+ 800 sealed artefacts  
+ 8.000 picture elements  
+ 1.200 inscriptions  
(legends/captions)

**until 10/2023**  
c. 25.000 seals

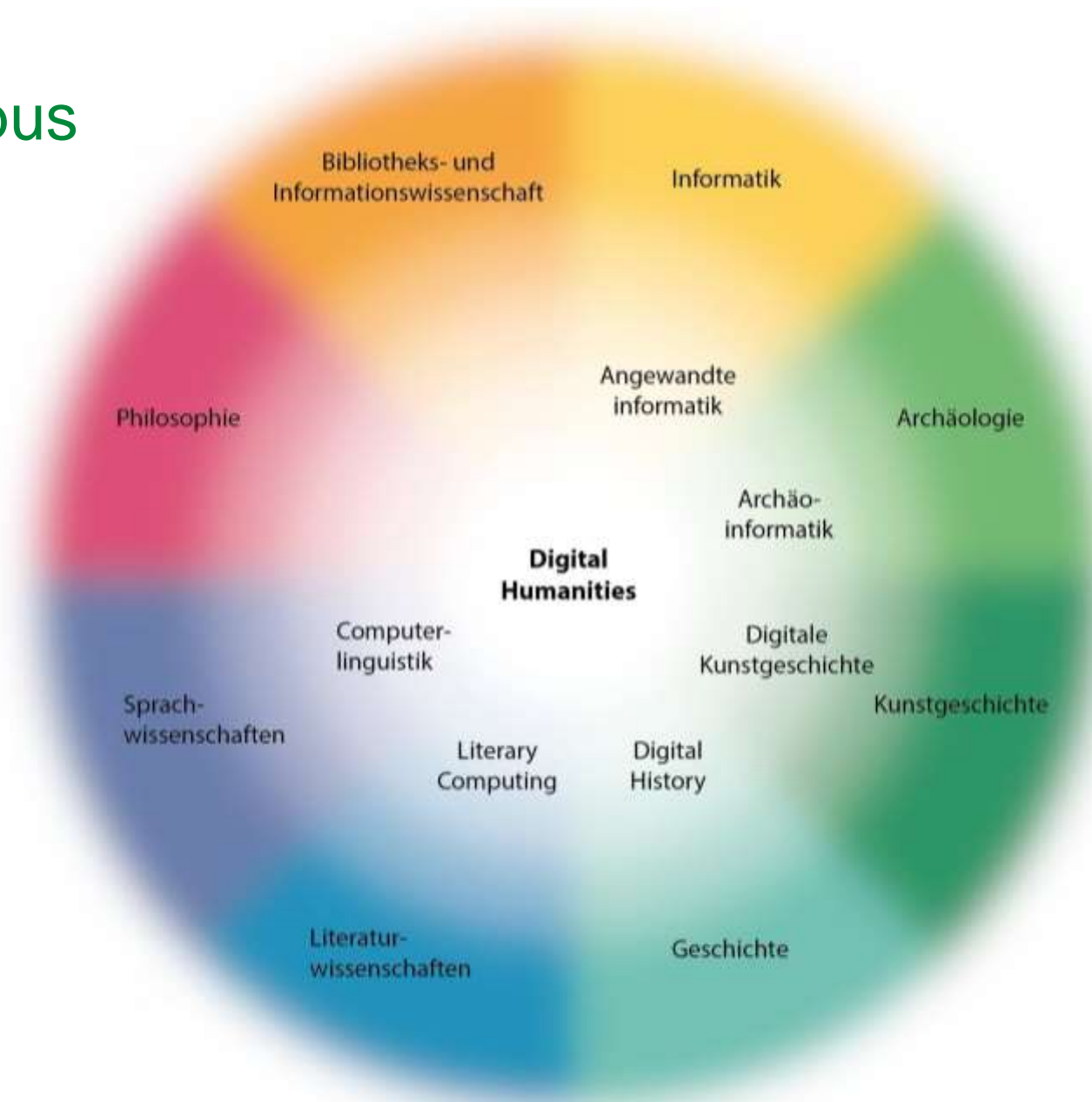

Graphik: P. Sahle, DARIAH-DE Working Papers Nr. 1. Göttingen: GOEDOC 2013

**catalogues** (Blocher 1992; al-Gailani Werr 1986, Stein 1993, Colbow 2002, 1995, Herbordt 1992, Fügert ....)

**museum collections**  
(VAM Berlin, BM)

**online projects**  
(Diyala Archaeological database; Ur online...)

ACAWAI-CS

# Data Ontology (based on CIDOC-CRM)

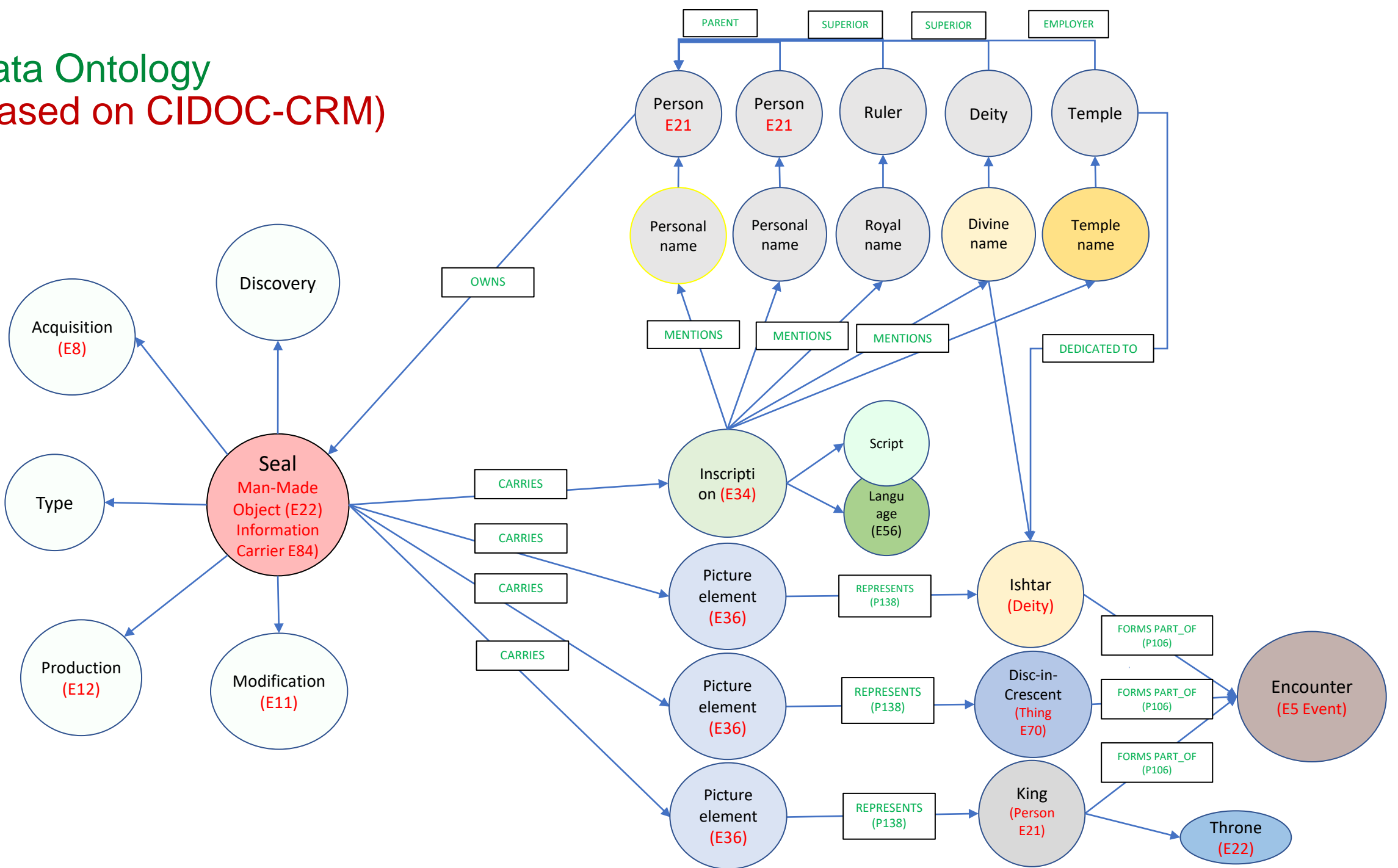

# Data Ontology (based on CIDOC-CRM)

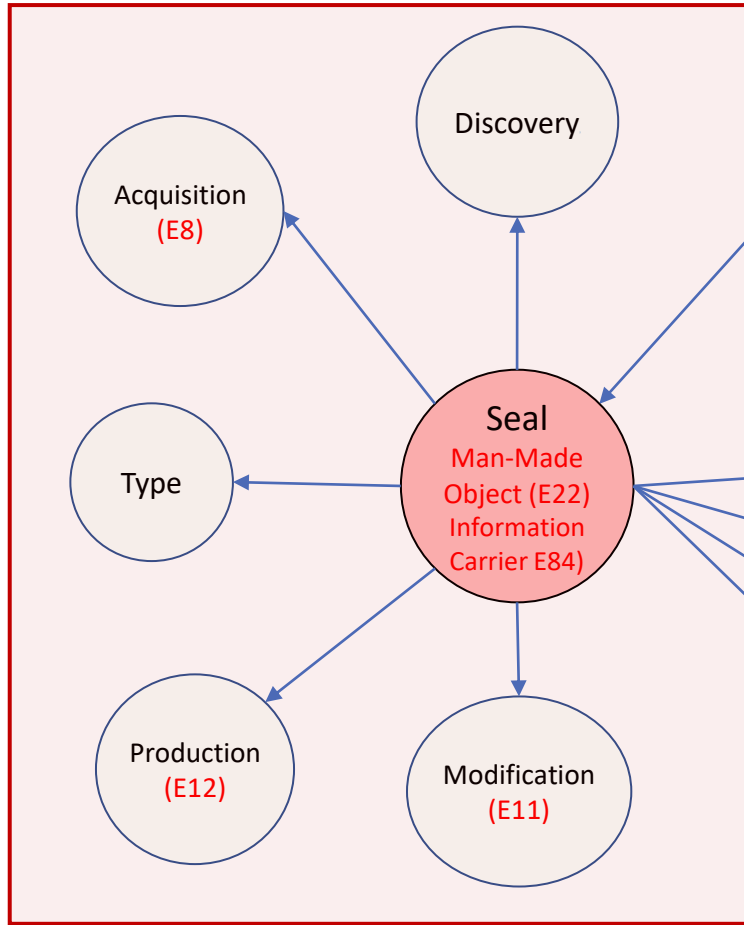

**ARTEFACT**

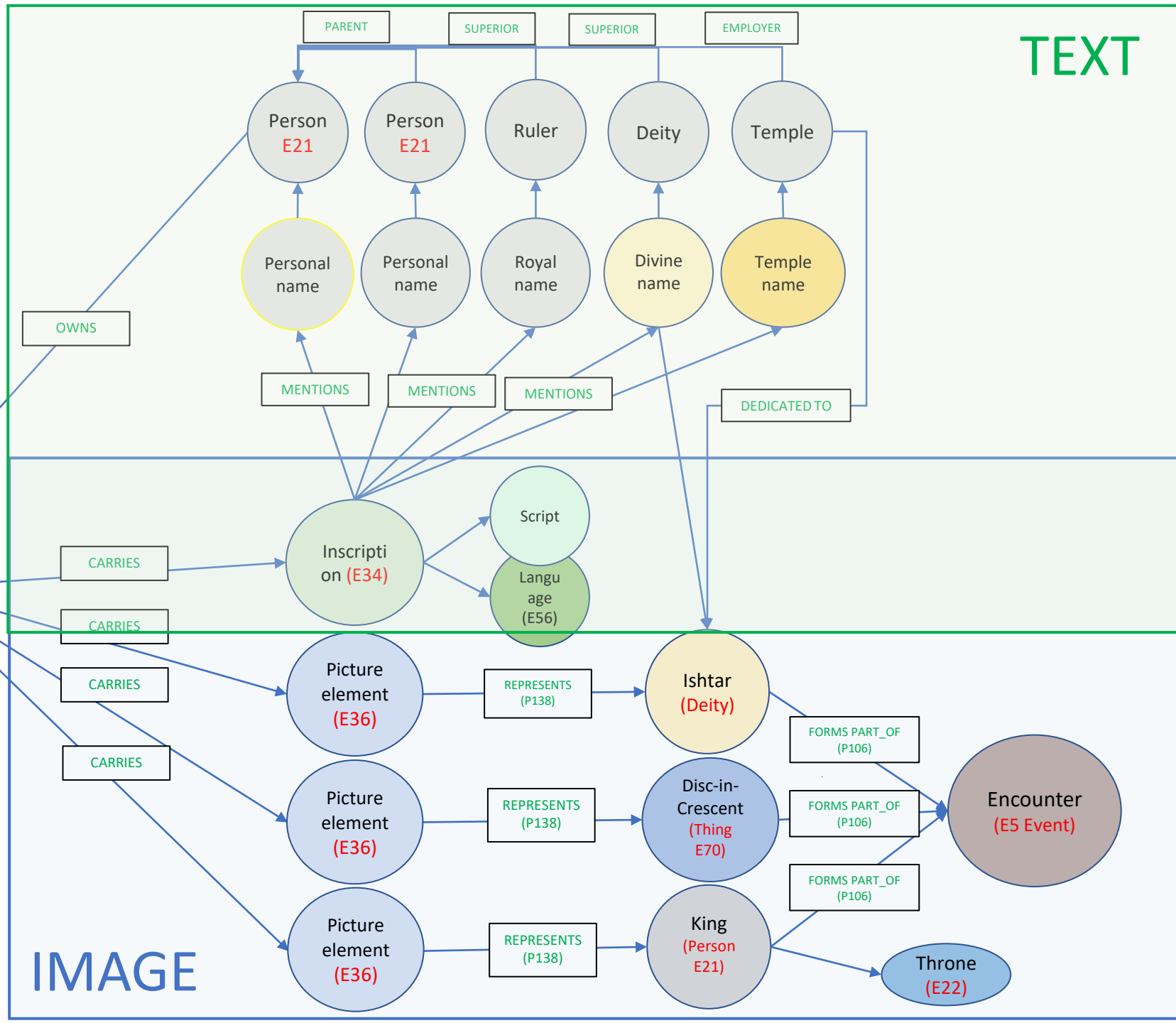

**TEXT**

**IMAGE**



# IMAGE

photo /drawing of modern /ancient seal impression

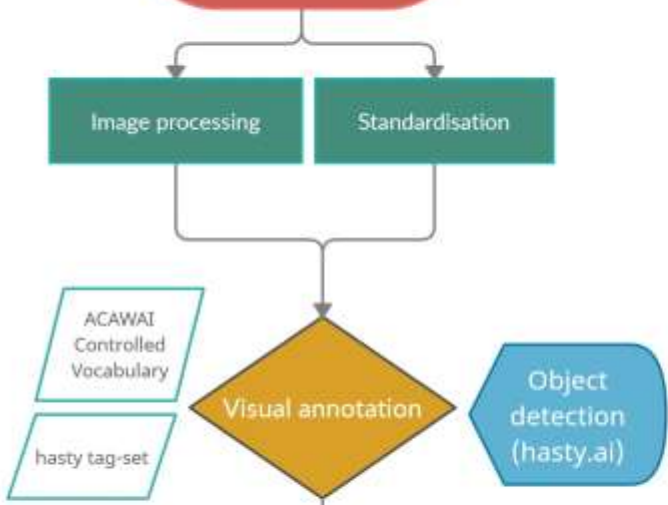

# TEXT

transliteration of seal inscription or seal impression caption

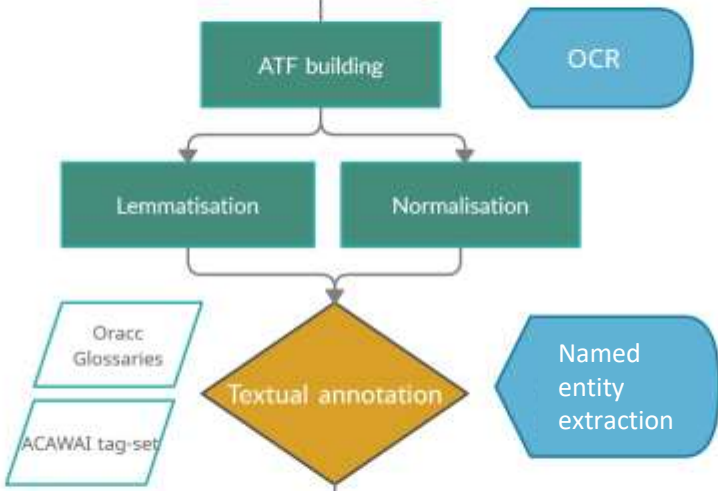

catalogue data / object and findspot information

# ARTEFACT

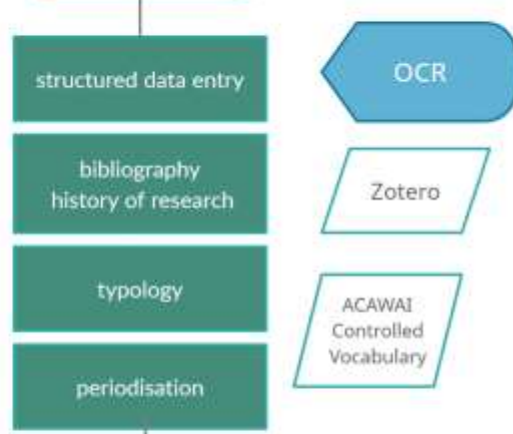

# ACAWAI-CS Workflow

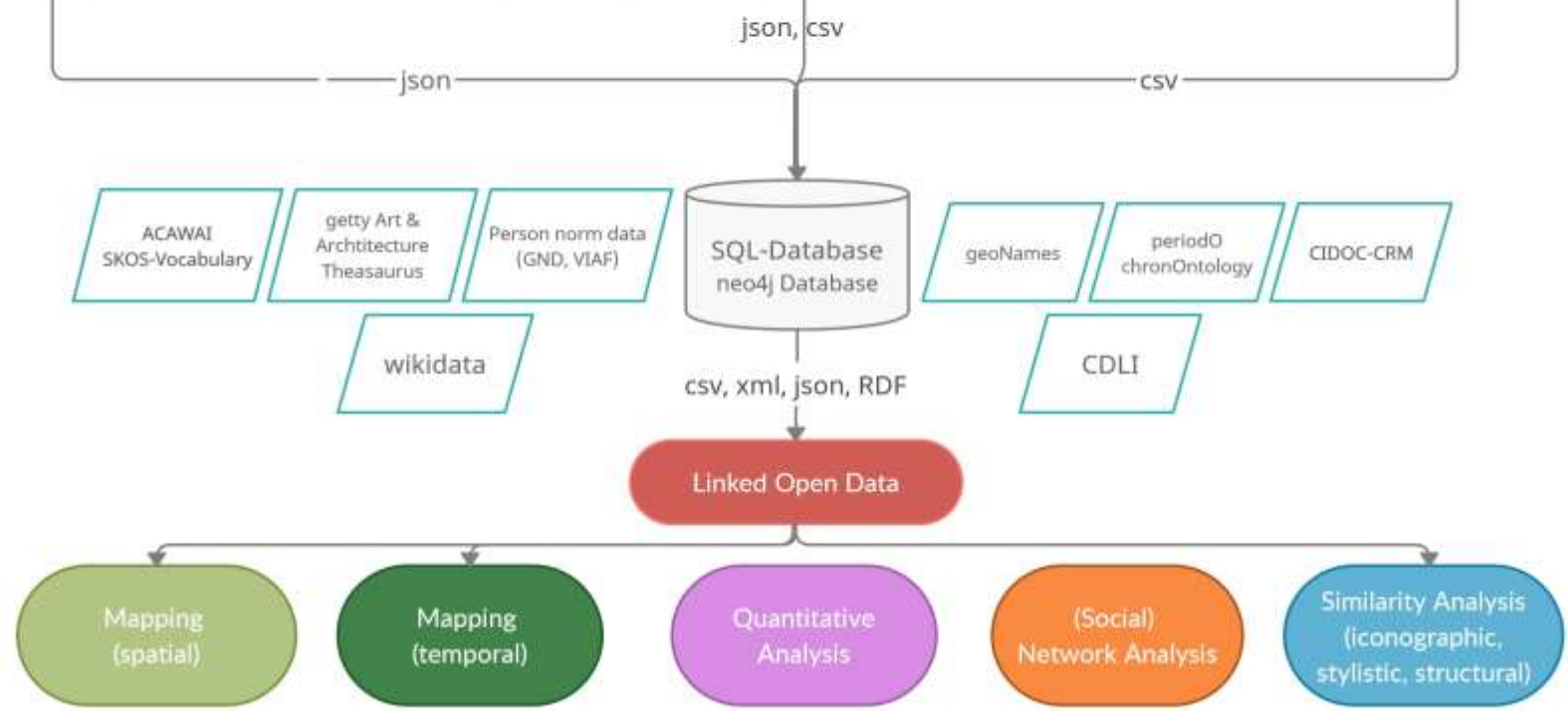

# Data Management: Relational database model (mySQL)

## SQL (Structured Query Language)

- free open-source programming language
- standard database language that is used to create, maintain and retrieve relational databases
- integrates with many database management systems

## relational database model:

- data is structured in interrelated tables (columns and rows)
- data is addressed by unique identifiers
- tables are related to each other: one-to-one, one-to-many, many-to-many (1:1, 1:n, n:1; n:m)
- data-import & export



## table seal

sealID	type	collection_no
1	cylinder	BM 82435
2	cylinder	BM 82451

## table jointBibliographySeal

publID	cat_no	biblID	sealID
publ1	220	bibl1	seal1
publ2	26	bibl1	seal2
publ3	182a	bibl2	seal2

## table bibliography

biblID	autor	year
1	Blocher	1992b
2	Gailani Werr, al- 1988	1988

# Data Management: Relational database model (mySQL)

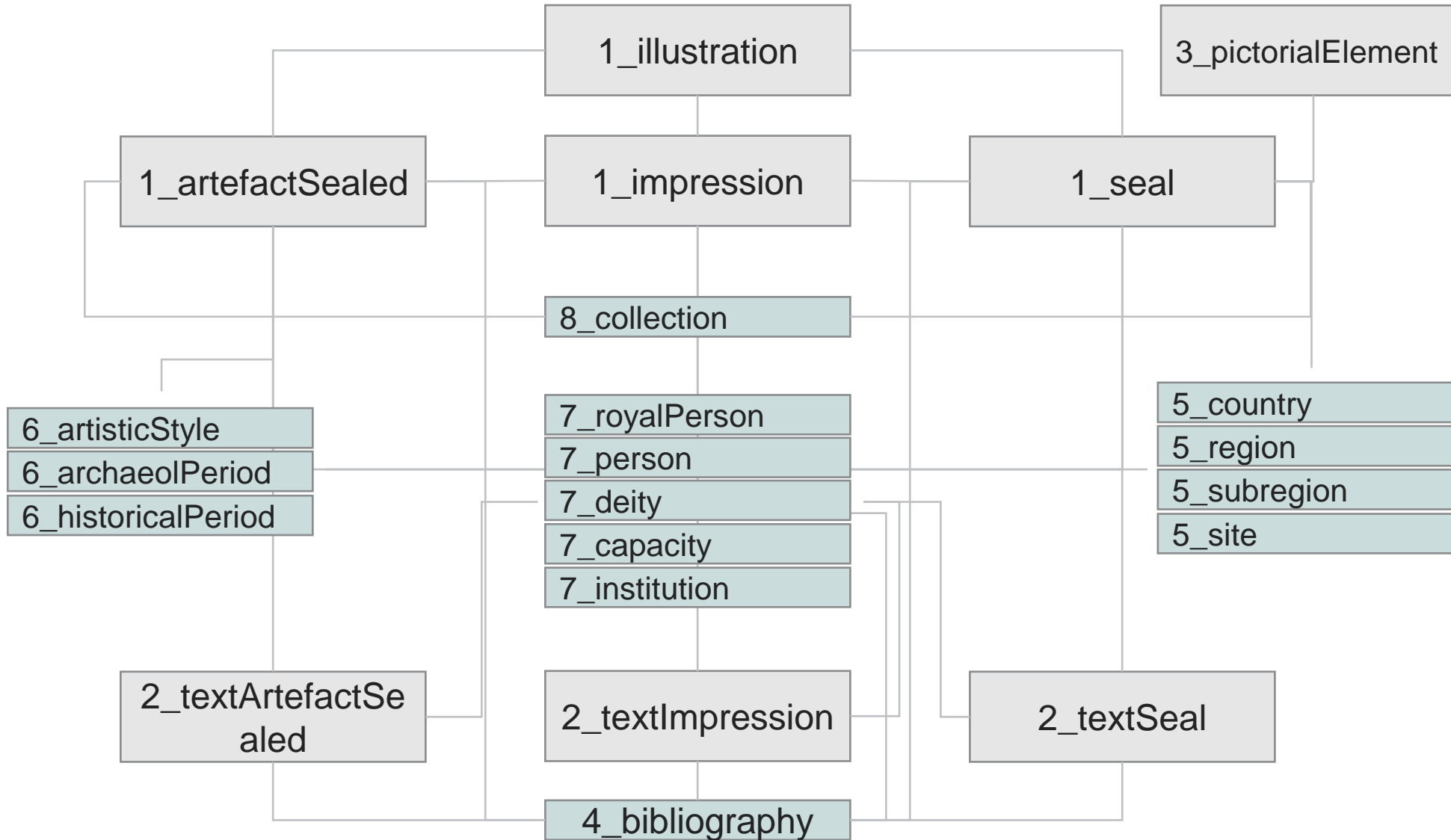

5_site
<b>siteID</b>
site_name
site_ancient
site_modern
latitude
longitude
<b>wikidata</b>
<b>DAI_gazetteer</b>
<b>geonames</b>
<b>pleiades</b>
<b>subregionID</b>
<b>regionID</b>
<b>countryID</b>
comments

# Data Management: Relational database model (mySQL)

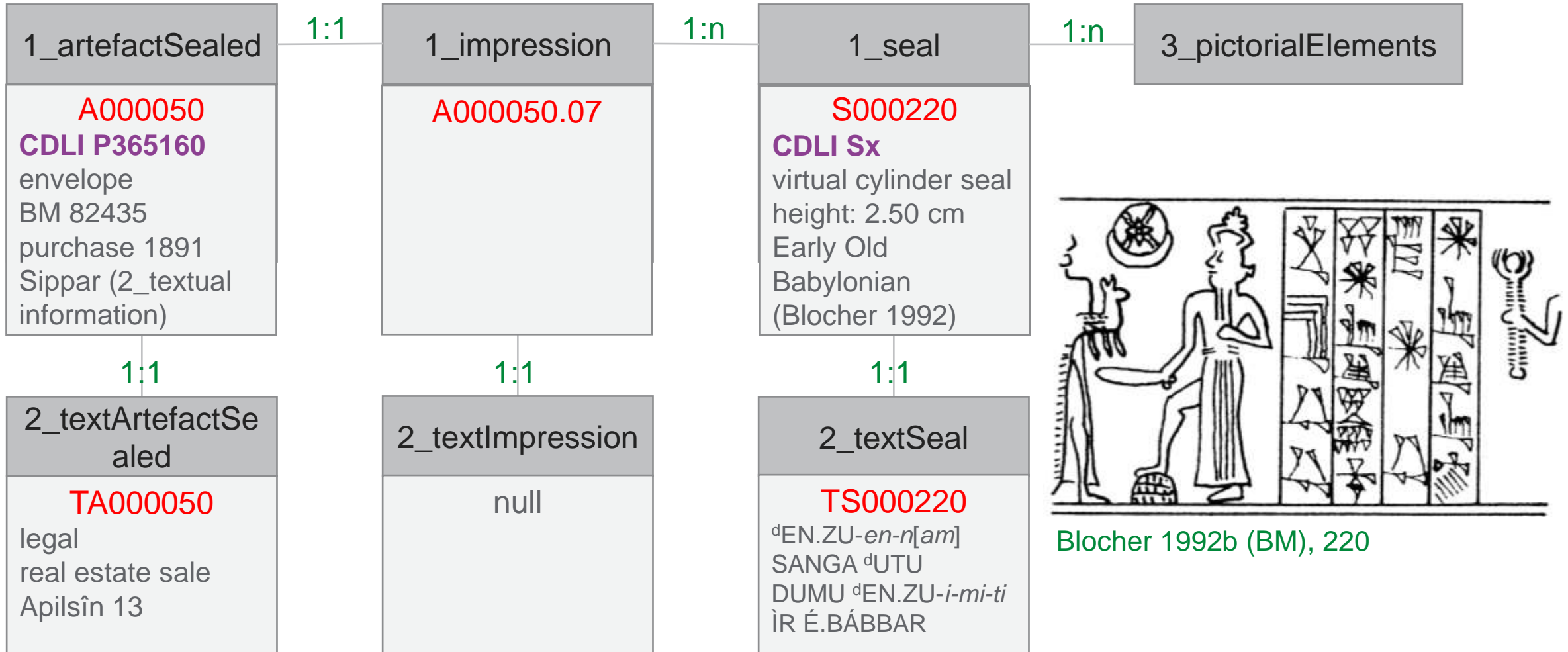



# Data Management: Graph database model (neo4j)



Blocher 1992b (BM), 220

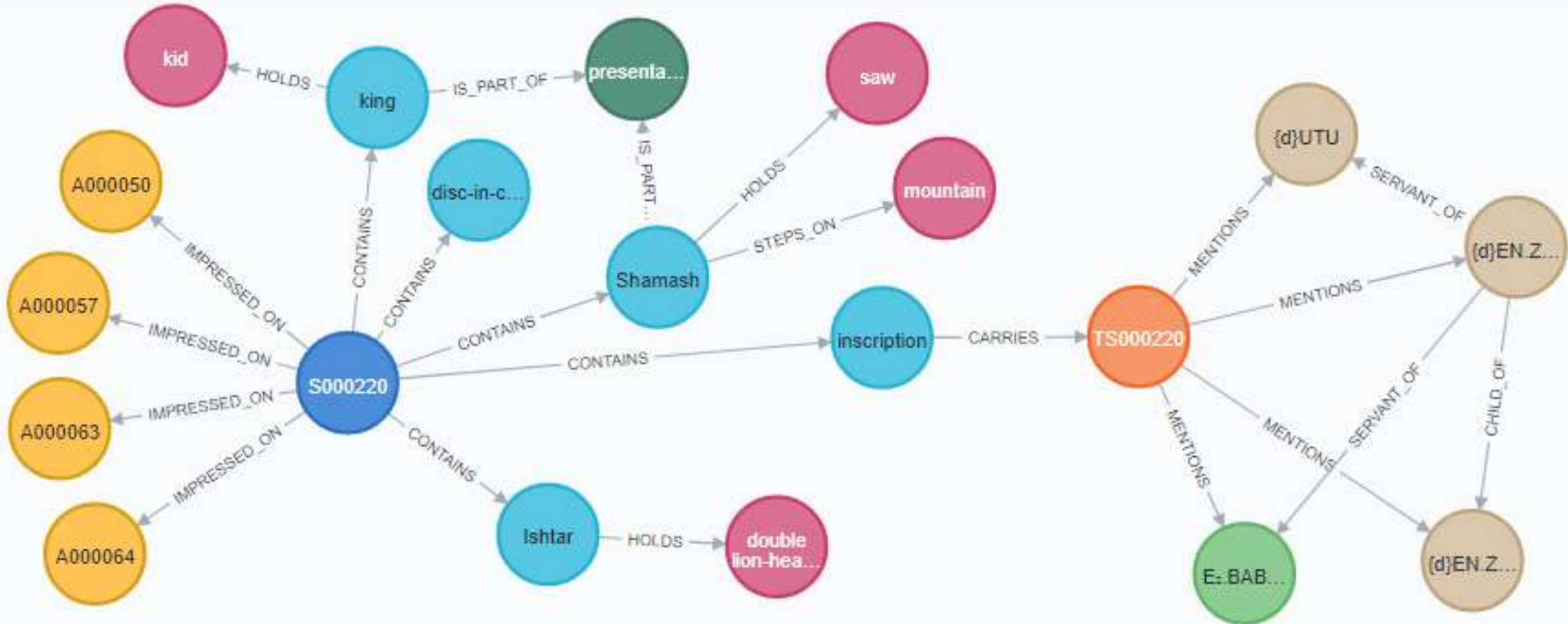

# Data Management: Graph database model (neo4j)

<id>: 77509

**classification:** deity **gender:** male **name:** Shamash **posture:** stepping on  
**gesture:** holding sth **body\_orientation:** profile left **face\_orientation:** profile  
left **beard:** long beard **hairstyle:** tied-up **headdress:** horned headdress  
**garment:** long open skirt **cloth:** striped



Blocher 1992b (BM), 220

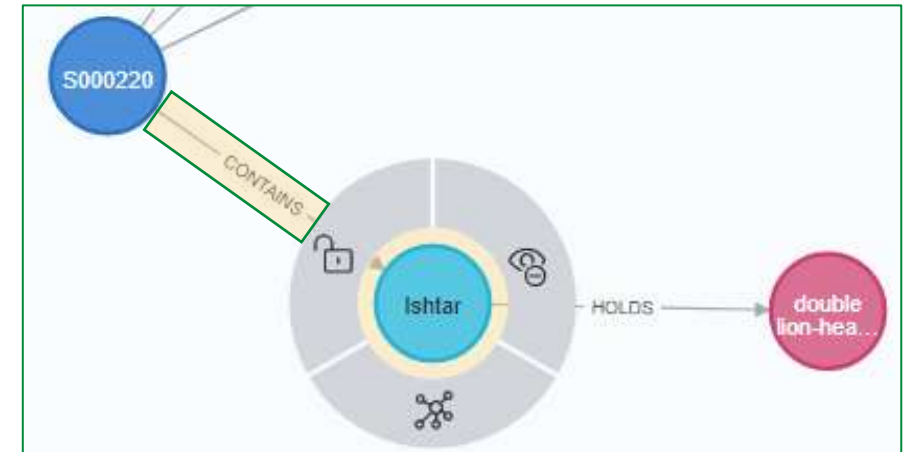
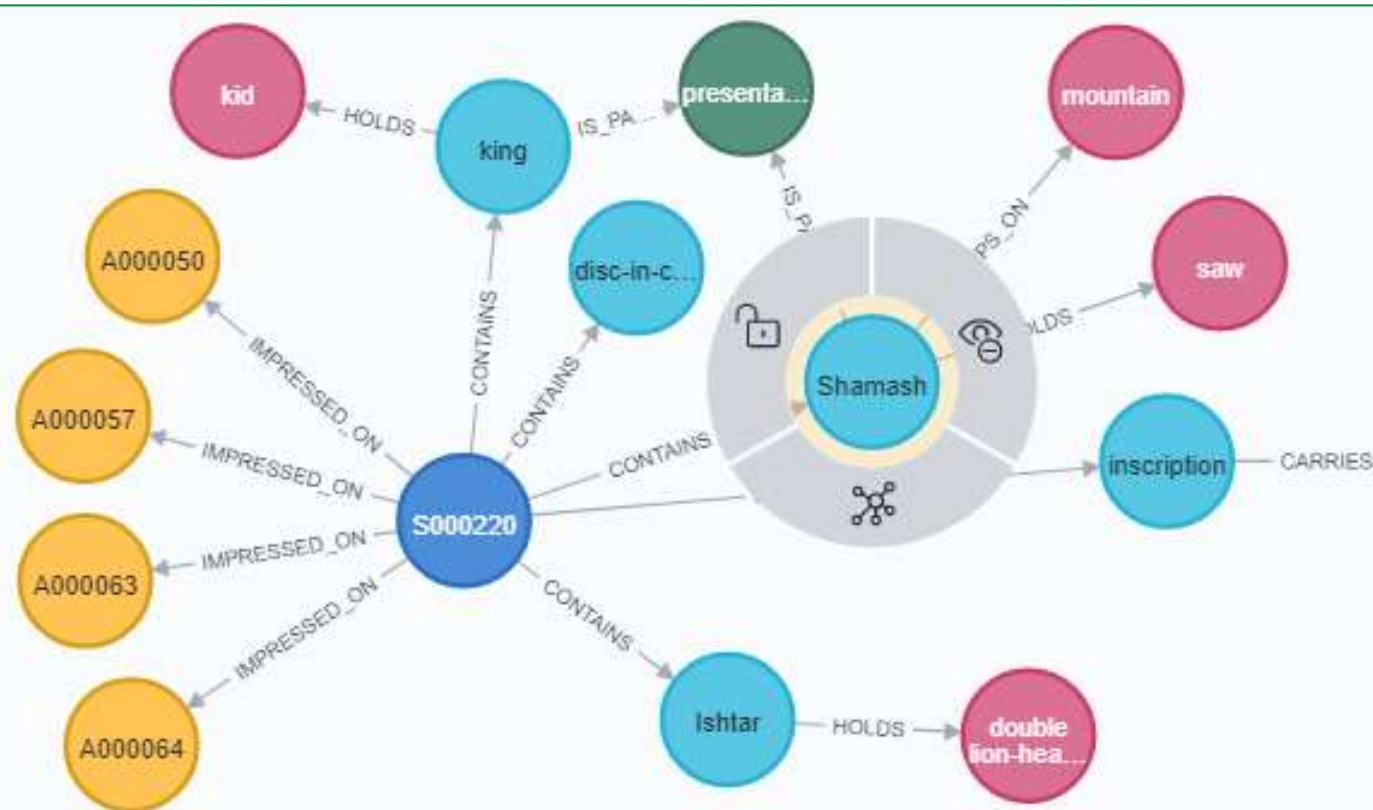

<id>: 57301

**relation\_property:** probable identification

<id>: 77511

**classification:** deity **gender:** female **name:** Ishtar  
**gesture:** holding sth **body\_orientation:** profile left

# Data Management: Graph database model (neo4j)

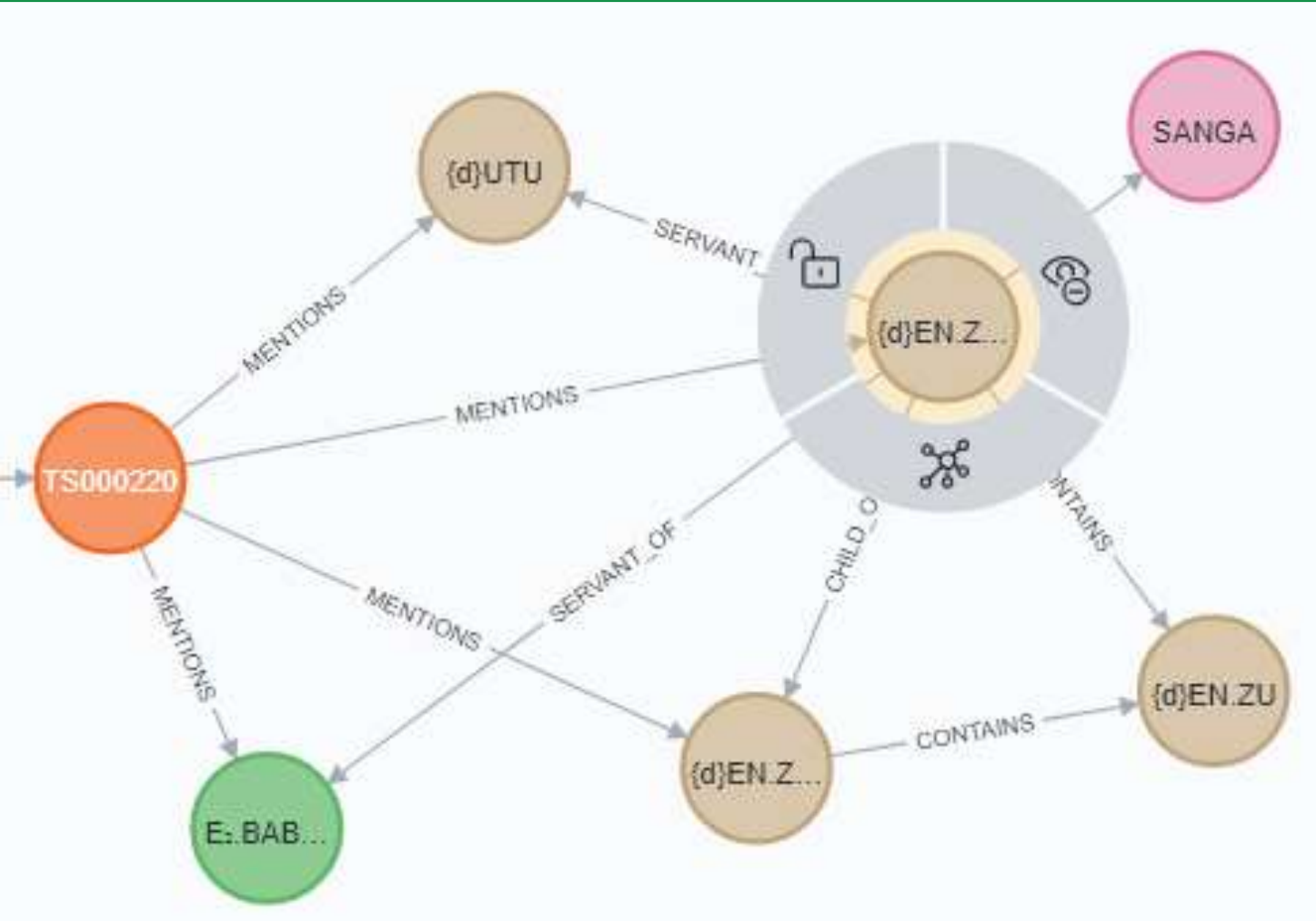

- Dealing with uncertainties
- Capturing complex relationships
- Social Network Analysis
- Interoperability with semantic web ontologies (CIDOC-CRM) and vocabularies (schema.org) organized in triple-stores (RDF, wikidata) with SPARQL as query language

## Transliteration:

<sup>d</sup>EN.ZU-*en-n[am]*  
 SANGA <sup>d</sup>UTU  
 DUMU <sup>d</sup>EN.ZU-*i-mi-ti*  
 ÌR É.BÁBBAR

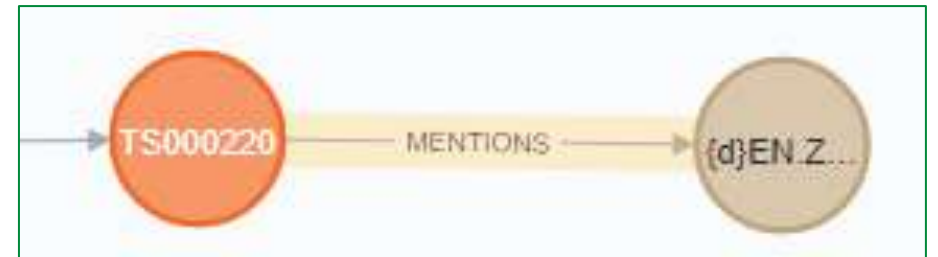

**<id>:** 77513

**classification:** person **gender:** male **name:** <sup>d</sup>EN.ZU-*en-n[am]* **capacity:** SANGA <sup>d</sup>UTU

**<id>:** 57326

**relation\_property:** seal owner



# Annotation 1: Visual components

## Object Detection with Machine Learning

- Neural Networks suppress human capabilities in **Object Detection** tasks
- Able to **generalize from examples**

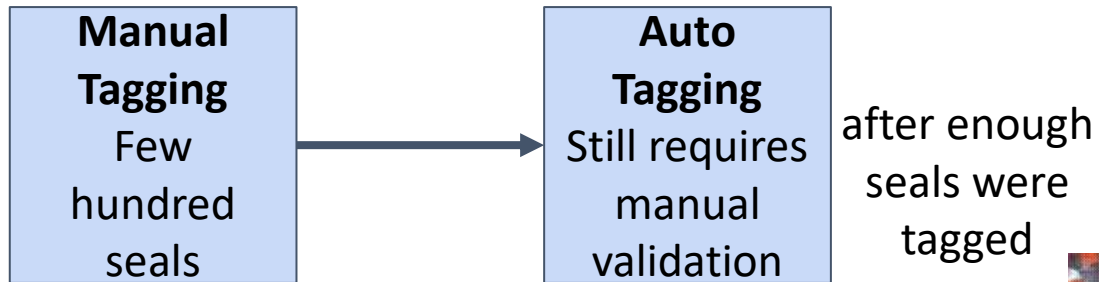

# Annotation 1: Visual components

## Challenges of cylinder seal dataset

- Preservation condition
- Style differences



cross: 97%

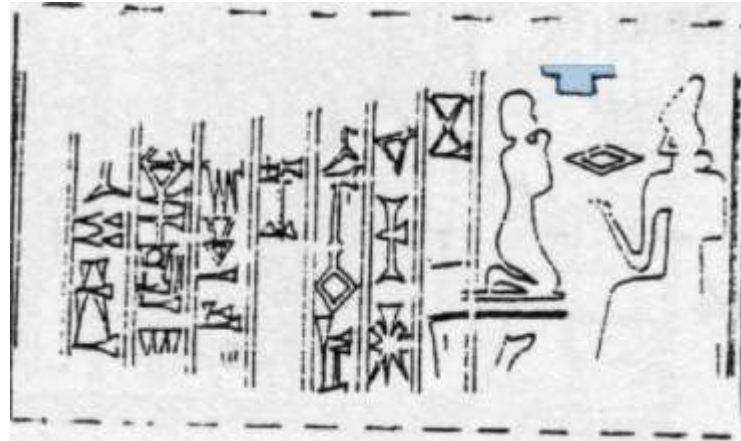

cross: 6%

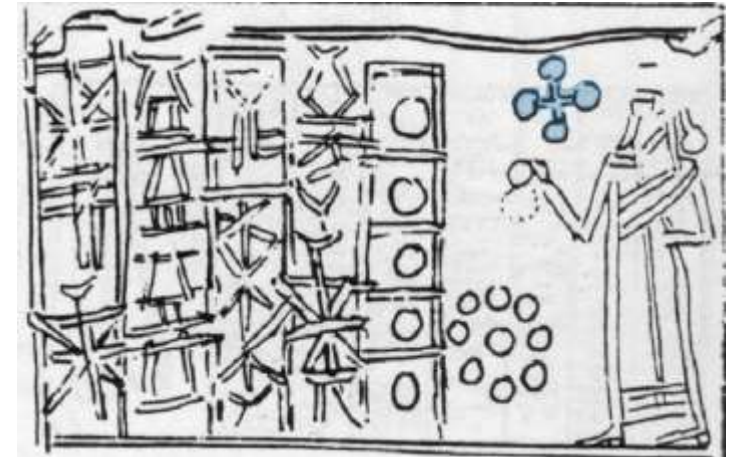

cross: 25%

# Annotation 1: Visual components. Object detection with



1 label selected

Class prediction:

[Annotation](#) [Help](#)

LABEL CLASSES + ▾

LABEL ATTRIBUTES + ▾

IMAGE TAGS ▾

HISTORY ▾

# Annotation 1: Visual components. Class attributes with



The screenshot displays the Hasty annotation tool interface. The central workspace shows an ancient Egyptian drawing with several colored bounding boxes: a light blue box around a figure, a purple box around a column of hieroglyphs, a light blue box around a smaller figure, and a light blue box around a circular symbol. The left sidebar contains a vertical menu with categories: SERVICES, AI ASSISTANTS (with sub-items AL, OD, IS, SES, BTI), and MANUAL TOOLS. The right sidebar contains controls: 'Class prediction' (toggle on), 'Annotation' (selected) and 'Help' buttons, 'LABEL CLASSES' and 'LABEL ATTRIBUTES' sections with expand/collapse arrows, 'Attribute prediction' (toggle on), 'No labels selected' text, and 'IMAGE TAGS' and 'HISTORY' sections with expand/collapse arrows.

# Annotation 1: Visual components

## Limitations

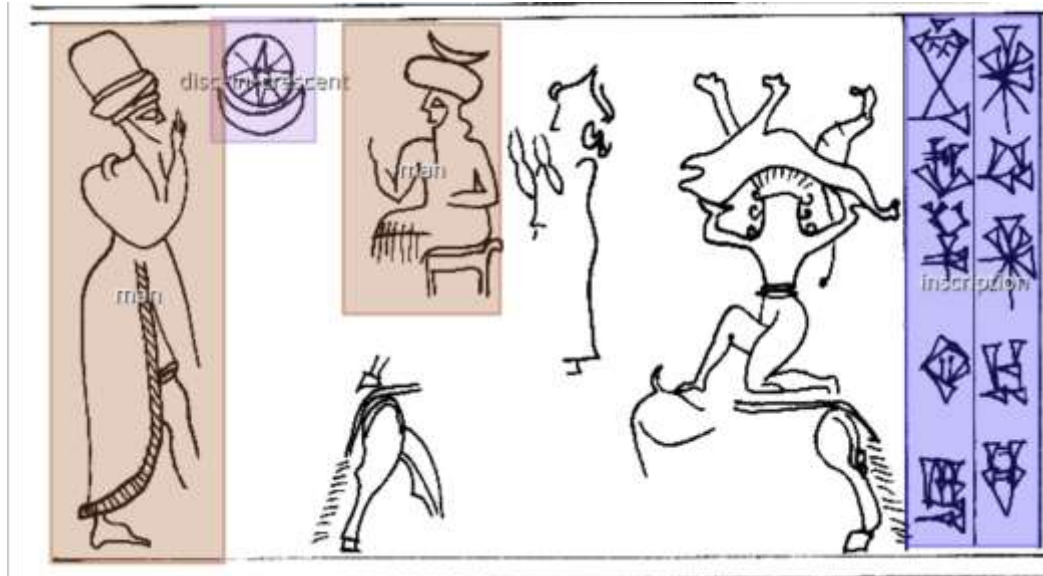

Different region (Tell Leilan, Syria)

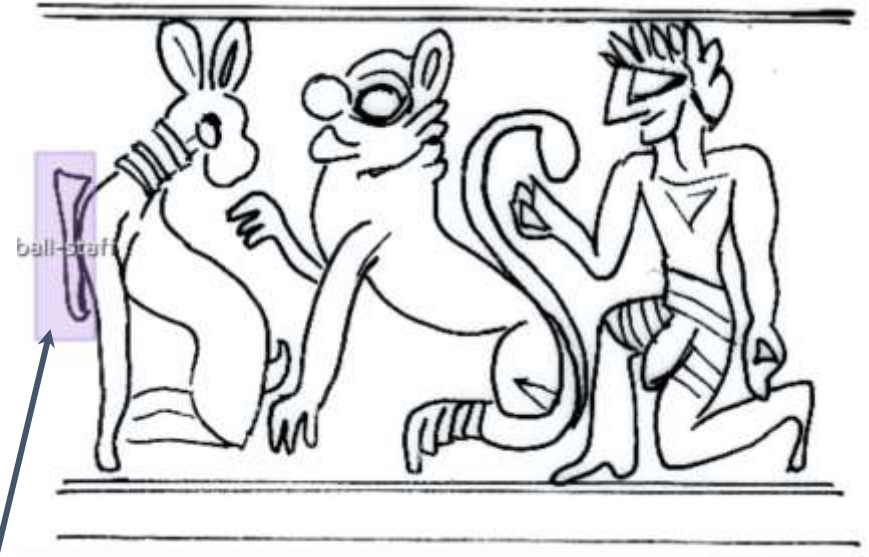

Not explainable, requires review

































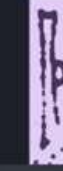

Not a "ball-staff"!

# Manual Review- Class “ball-staff”

Manual review for: ACAWAI-CS - Drawings

Capacity (%) 40 51 annotations found

Items per page 60

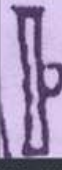
 Annotation 6d0d0f22-11fb-4c76-a65b-fe907bb99c12 Class: ball-staff	 Annotation 702d31b3-0687-4e00-80b4-c3707e9d020e Class: ball-staff	 Annotation 7778315c-bd42-47a9-893d-5a920715c957 Class: ball-staff	 Annotation 1ac885da-9539-4c76-bf31-c5d6848743e0 Class: ball-staff	 Annotation 4db1e66b-a751-41ee-8b55-90f1494a0e0d Class: ball-staff	 Annotation a1e9c714-82a5-41b9-8040-2ef23694bdbc Class: ball-staff	 Annotation 983507dc-3ad0-47e7-9fd3-c67504002492 Class: ball-staff	 Annotation 20a2578-d51e-411f-be37-4bc108c7f516 Class: ball-staff	 Annotation 7de9d879-a623-4884-9409-5646e406f6f8 Class: ball-staff
 Annotation be9630b6-5cb7-4919-9e06-d6425bc47b0 Class: ball-staff	 Annotation 0994aa3c-943b-47ae-a7d7-9a1c11fa15ba Class: ball-staff	 Annotation 1e02d3be-ee9a-415f-a957-b5f1649f42a4 Class: ball-staff	 Annotation dd07ea95-4c42-4323-b97b-48582550862f Class: ball-staff	 Annotation a9b1060e-2df3-4b1e-bae0-e5893c2bf6e1 Class: ball-staff	 Annotation a8bfc6b8-27de-4ae2-957f-463531e85e70 Class: ball-staff	 Annotation 510698a4-418d-400f-abd9-0f75fef62e43 Class: ball-staff	 Annotation 745a616c-2572-4996-86f1-b0073act01ff Class: ball-staff	 Annotation 91643cae-7a69-4f83-96fa-fd7192b8e1c7 Class: ball-staff
 Annotation eelb5278-8668-4811-b596-99d56306a2f6 Class: ball-staff	 Annotation 346a8608-9d8e-42cb-b717-fcaef1efeb69 Class: ball-staff	 Annotation 1923d650-9002-4e51-bf53-fd1cef32e944 Class: ball-staff	 Annotation 7757a08a-1891-46cd-bdb7-d05c906d2b05 Class: ball-staff	 Annotation 9d84af0f-8a53-446c-8555-aae1e7277c1a Class: ball-staff	 Annotation e8ec592a-df55-4d32-a77d-aaef6c01dc Class: ball-staff	 Annotation 6121245e-d224-4849-ab15-662bf6a11188 Class: ball-staff	 Annotation f2b00fed-34cc-4067-a583-5606b24aa2e8 Class: ball-staff	 Annotation f6bec3de-cde4-46bd-9b04-7786ae6556c8 Class: ball-staff
 Annotation d2b30b0d-ba36-4f0b-bbce-8533373523b1 Class: ball-staff	 Annotation 1ca86764-63d8-4174-a1d1-02c6b05ca750 Class: ball-staff	 Annotation 67d8ff13-f83e-402f-bd11-64a273d08560 Class: ball-staff	 Annotation ec620d08-2fc9-4177-94a3-117227f07ce5 Class: ball-staff	 Annotation 8212aa82-90f4-4545-9afa-2038c7f961da Class: ball-staff	 Annotation 595bffa1-9fb7-4d63-9e3c-22b18838879b Class: ball-staff	 Annotation 1500df42-2d43-483c-b787-cf46b6539f3 Class: ball-staff	 Annotation 2a720c7a-f1e9-48fb-83d9-a6447861ecb1 Class: ball-staff	 Annotation 3b00042a-0b16-40f2-97e7-cc3506533ab Class: ball-staff

# Output

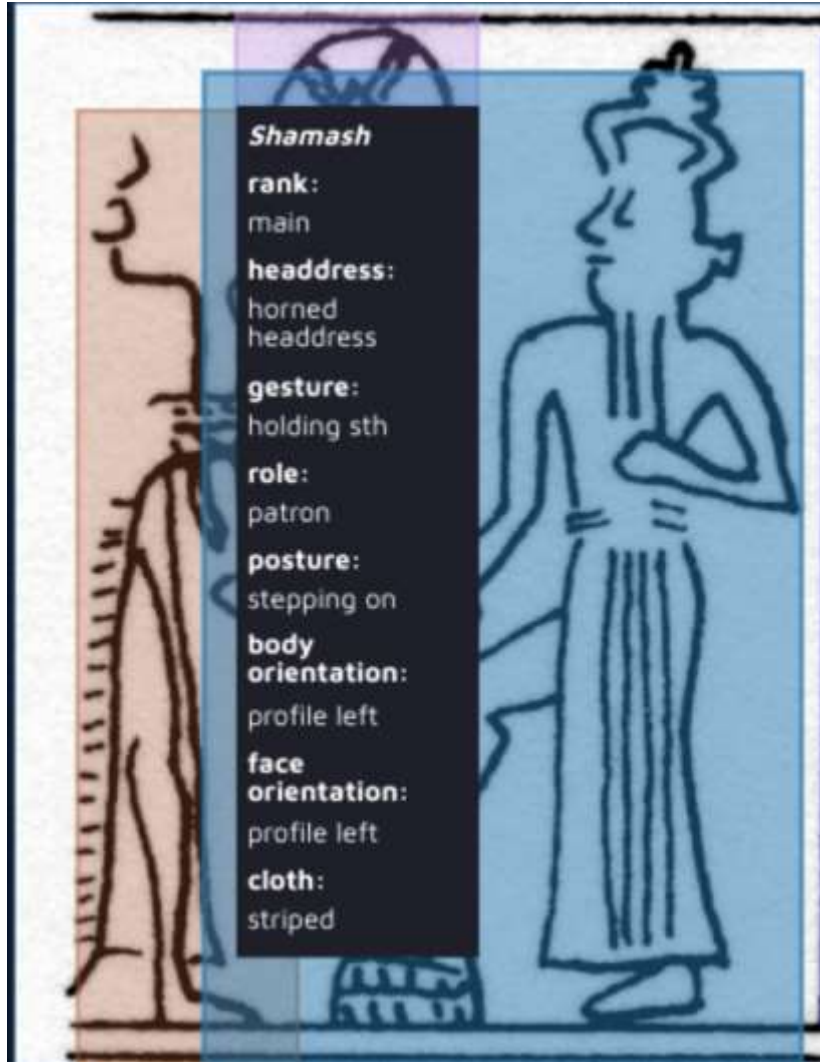

```
1698 "image_id": "1062a7f1-f04f-45e6-80f2-be378349df32",  
1699 "width": 2095,  
1700 "height": 1228,  
1701 "image_name": "Blocher 1992b,220.jpg",  
1702 "labels": [  
1703   {  
1704     "id": "19b788f5-54cb-434e-a706-b4d23f426510",  
1705     "class name": "Shamash",  
1706     "bbox": [  
1707       217,  
1708       79,  
1709       907,  
1710       1223  
1711     ],  
1712     "attributes": {  
1713       "role": [  
1714         "patron"  
1715       ],  
1716       "cloth": "striped",  
1717       "rank": "main",  
1718       "posture": "stepping on",  
1719       "gesture": [  
1720         "holding sth"  
1721       ],  
1722       "headdress": "horned headdress",  
1723       "body orientation": "profile left",  
1724       "face orientation": "profile left"  
1725     }  
1726   },
```

Coordinates indicate spatial relations between picture elements

# Annotation 2: Textual components

```

#P481311 = T000103 (P481311)
#project: acawai
#atf: use unicode
#atf: lang akk
#atf: use math
#atf: use legacy
1. [a]-bu-wa-qar
#lem: +Abuwaqar[]PNS

2. [DU]MU DUG-i-i-[i]-šu
#lem: mār[son]N: +Tāb-ilišu[father of Abuwaqar]PNS

3. DAM.[GĀR]
#lem: tamkāru[merchant]N

4. IR (d)[x]
#lem: warad[servant]N: u

@translation labeled on project
@(1 - 4) Abuwaqar, son of Tāb-ilišu, merchant, servant of x
    
```

## Lemmatizing in Oracc

Oracc Search: P481311 (j=η sz=š s,=š t,=t 0-9=0-9; '=alef)

6 Texts [6 matches] English only

MHET 2/1, 054 [Litigation]

Names

- MHET 2/1, 054
  - 1. [a]-bu-wa-qar
  - 2. [DU]MU DUG-i-i-[i]-šu
  - 3. DAM.[GĀR]
  - 4. IR (d)[x]

Numbers

- CDLI P481311
- BM 017050
- MHET 2/1, 054

View

- Catalogue entry
- Print text

Details

ACAIAI : The Annotated Corpus of Ancient West Asian Imagery: Cylinder Seals



*tamkāru* [MERCHANT] (N) 11 instances

Written forms: DAM.GĀR.

Normalized forms: tamkāru (DAM.GĀR).

1. merchant (11x/100%)

### Glossaries

<b>Akkadian</b>	Summaries	Letter by Letter	One Big File
Proper Nouns	Summaries	Letter by Letter	One Big File
Celestial Names	Summaries	Letter by Letter	One Big File
Divine Names	Summaries	Letter by Letter	One Big File
Ethnic Names	Summaries	Letter by Letter	One Big File
Month Names	Summaries	Letter by Letter	One Big File
Object Names	Summaries	Letter by Letter	One Big File
People	Summaries	Letter by Letter	One Big File
Places	Summaries	Letter by Letter	One Big File
Temples	Summaries	Letter by Letter	One Big File
Watercourses	Summaries	Letter by Letter	One Big File
Sumerian	Summaries	Letter by Letter	One Big File



## Additional tags for Social Network Analysis?



## Oracc - Tags

N, V, AJ, CNJ...

PN

CN

DN

EN

MN

ON

GN/EN

GN

TN

WN

## Glossaries

Akkadian	Summaries	Letter by Letter	One Big File
Proper Nouns	Summaries	Letter by Letter	One Big File
Celestial Names	Summaries	Letter by Letter	One Big File
Divine Names	Summaries	Letter by Letter	One Big File
Ethnic Names	Summaries	Letter by Letter	One Big File
Month Names	Summaries	Letter by Letter	One Big File
Object Names	Summaries	Letter by Letter	One Big File
People	Summaries	Letter by Letter	One Big File
Places	Summaries	Letter by Letter	One Big File
Temples	Summaries	Letter by Letter	One Big File
Watercourses	Summaries	Letter by Letter	One Big File



&P365160 = **A000050** (Blocher 1992b,219-220)

- #project: acawal
- #atf: use unicode
- #atf: lang akk
- #atf: use math
- #atf: use legacy

@tablet  
 @seal 1  
 #TA000050.01  
 1. KIŠIB a-ḫu-ši-na

@seal 2  
 \$ (uninscribed seal; caption)  
 #TA000050.02  
 1. KIŠIB {d}UTU-na-šir

@seal 7  
 #TS000220  
 1. {d}EN.ZU-en-n[am]  
 2. SANGA {d}UTU  
 3. DUMU {d}EN.ZU-i-mi-ti  
 4. ÌR É.BÁBBAR

IDS

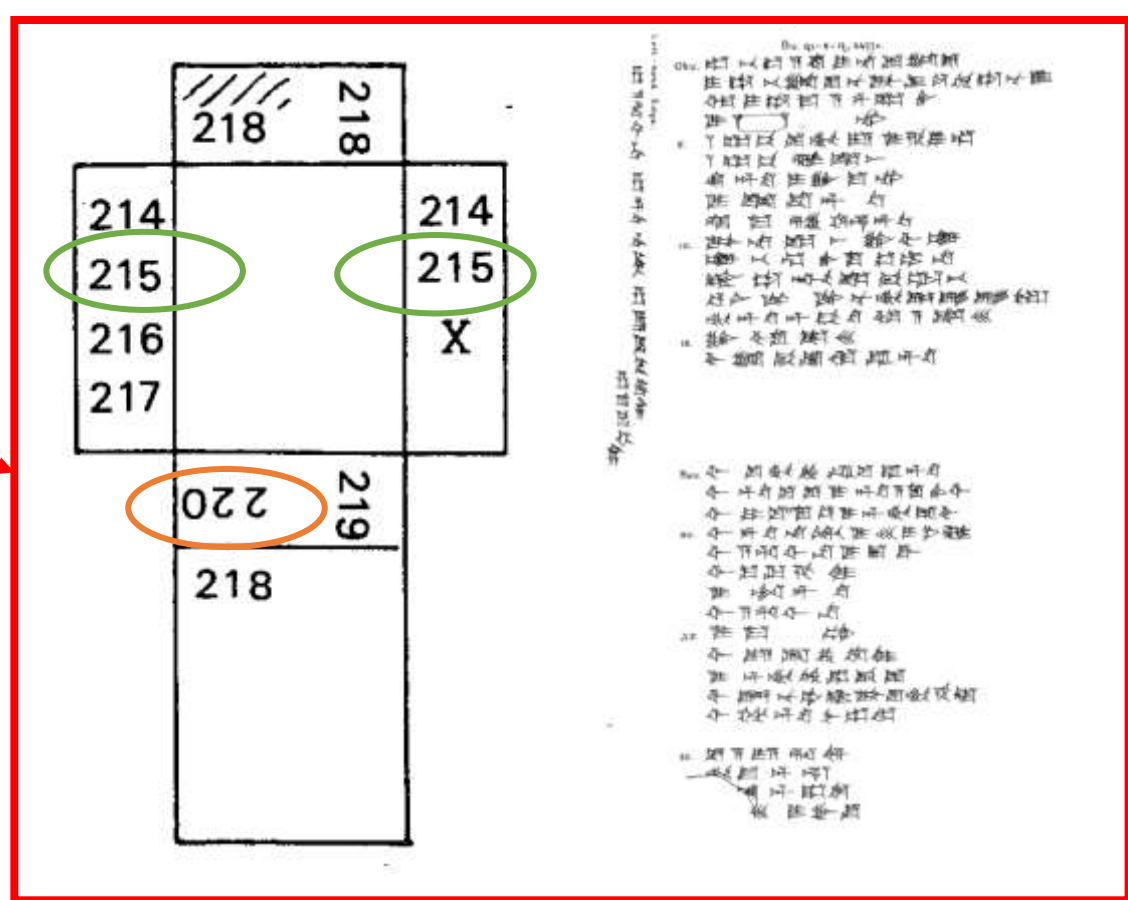

&P365160 = **A00050** (Blocher 1992b,219-220)

#project: acawai  
#atf: use unicode  
#atf: lang akk  
#atf: use math  
#atf: use legacy

@tablet  
@seal 1  
#TA00050.01

1. KIŠIB a-ḥu-ši-na

@seal 2  
\$ (uninscribed seal; caption)  
#TA00050.02

1. KIŠIB {d}UTU-na-šir

@seal 7  
#TS000220

1. {d}EN.ZU-en-n[am] **seal owner**  
2. SANGA {d}UTU  
3. DUMU {d}EN.ZU-i-mi-ti  
4. ÌR É.BÁBBAR

IDS

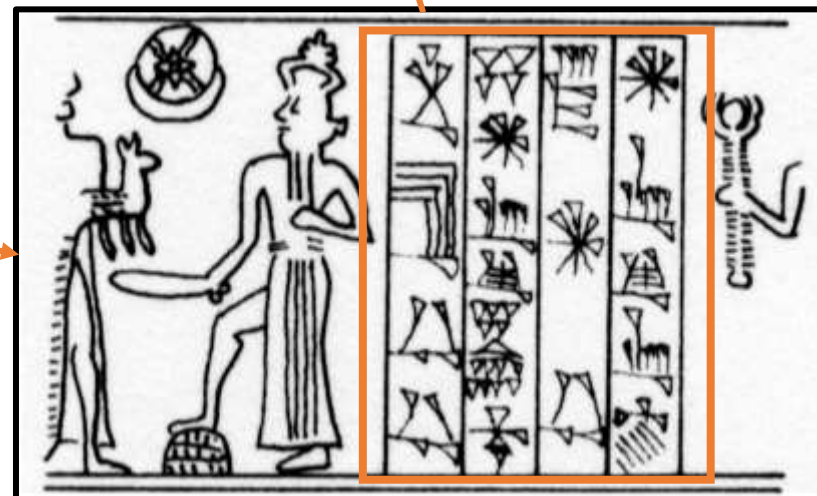
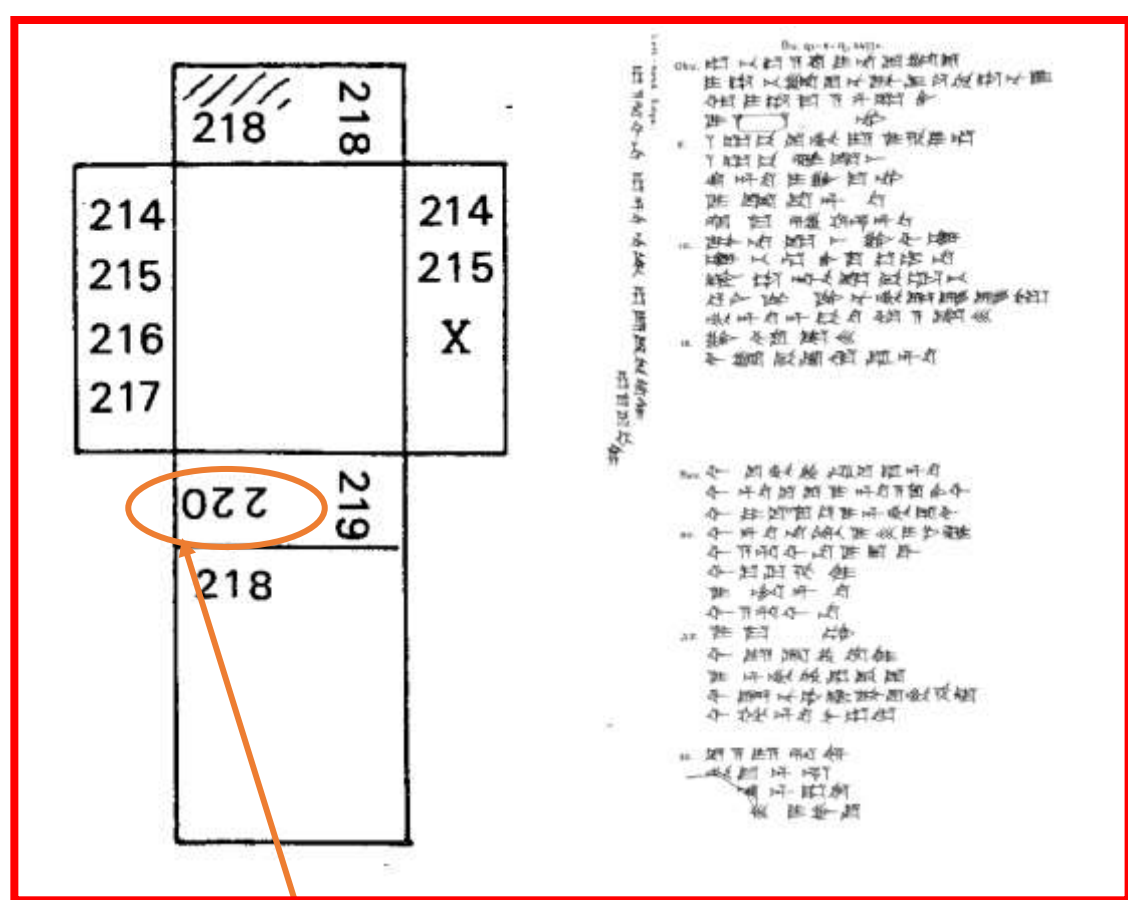

&P365160 = A00050 (Blocher 1992b,219-220)

#project: acawai  
#atf: use unicode  
#atf: lang akk  
#atf: use math  
#atf: use legacy

@tablet  
@seal 1  
#TA00050.01

1. KIŠIB a-ḫu-ši-na

@seal 2  
\$ (uninscribed seal; caption)

#TA00050.02

1. KIŠIB {d}UTU-na-šir  
seal user

@seal 7  
#TS000220

1. {d}EN.ZU-en-n[am]  
2. SANGA {d}UTU  
3. DUMU {d}EN.ZU-i-mi-ti  
4. ÌR É.BÁBBAR

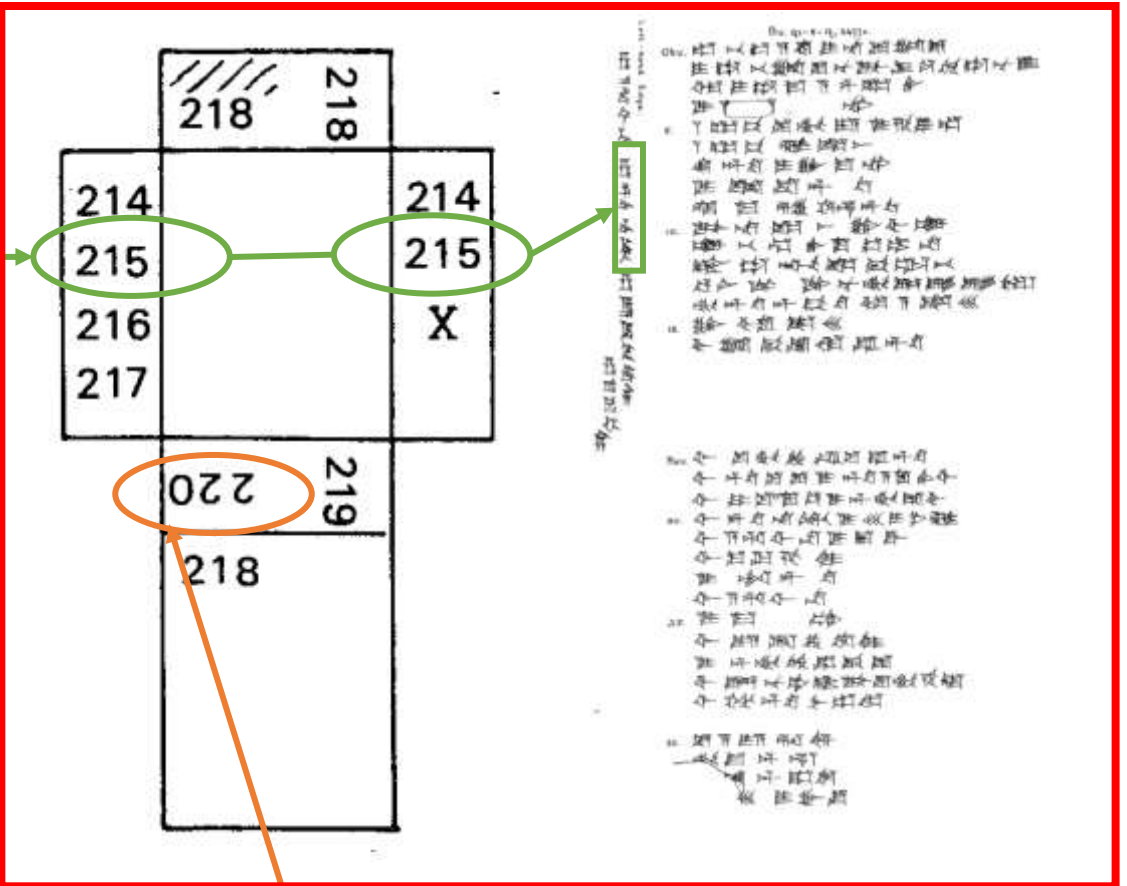
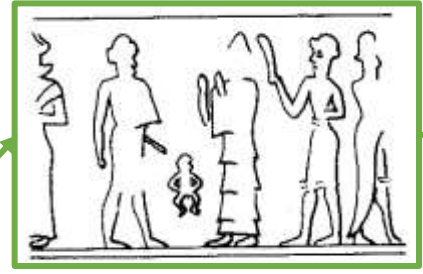

IDS



&P365160 = **A000050** (Blocher 1992b,219-220)

#project: acawai  
#atf: use unicode  
#atf: lang akk  
#atf: use math  
#atf: use legacy

@tablet  
@seal 1  
#TA000050.01  
1. KIŠIB a-ḫu-ši-na

@seal 2  
\$ (uninscribed seal; caption)  
#TA000050.02  
1. KIŠIB {d}UTU-na-šir

seal user

@seal 7  
#TS000220  
1. {d}EN.ZU-en-n[am]  
2. SANGA {d}UTU  
3. DUMU {d}EN.ZU-i-mi-ti  
4. ÌR É.BÁBBAR

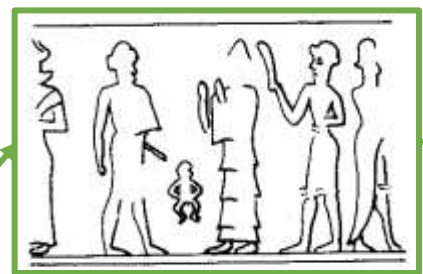

218	218	
214		214
215		215
216		X
217		
	219	
	220	
	218	

218 219 220

IDS



&P365160 = A000050 (Blocher 1992b,219-220)

#project: acawal  
#atf: use unicode  
#atf: lang akk  
#atf: use math  
#atf: use legacy

@tablet  
@seal 1  
#TA000050.01

1. KIŠIB a-ḥu-ši-na

@seal 2  
#TA000050.02

1. KIŠIB {d}UTU-na-šir

@seal 7  
#TS000220

seal inscription

IDS

Virtual Seal

Physical Seal

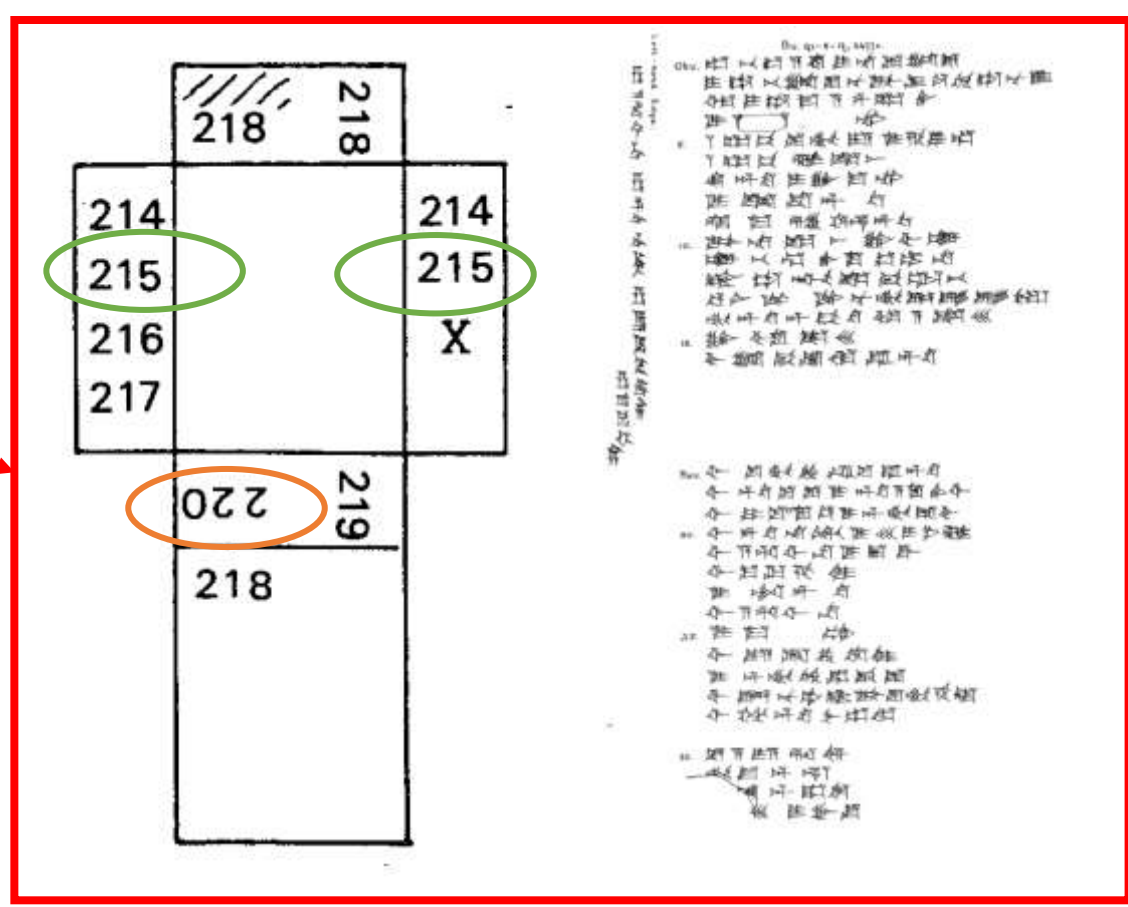

- 1. {d}EN.ZU-en-n[am]
- 2. SANGA {d}UTU
- 3. DUMU {d}EN.ZU-i-mi-ti
- 4. ÌR É.BÁBBAR

&P365160 = A000050 (Blocher

1992b,219-220)

#project: acawai

#atf: use unicode

#atf: lang akk

#atf: use math

#atf: use legacy

@tablet

@seal 1

#TA000050.01

1. KIŠIB a-ḫu-ši-na

#lem: kunukku[seal]N; Aḫušina[PN]

@seal 2

#TA000050.02

1. KIŠIB {d}UTU-na-šir

#lem: kunukku[seal]N; +šamaš-

našir[PN]š

@seal 7

#TS000220

1. {d}EN.ZU-en-n[am]

2. SANGA {d}UTU

3. DUMU {d}EN.ZU-i-mi-ti

4. ÌR É.BÁBBAR

1	Seal owner	[da]-da	Dada
2	Seal owner's profession	DAM.GAR <sub>3</sub>	merchant
3	Seal owner's patronymic/gender	DUMU/DUMU.MÍ du-du	son of Dudu
4	Seal owner's subordination/gender	ARAD/GÉME {d}nin-šubur	servant of the goddess Ninšubur

Set of rules



Script

NODE NAME: "Daughter"  
 LINE #: ANY  
 KEY WORDS: ["DUMU.MÍ",  
 "DUMU.MI2", "DUMU.MI2" ...]  
 NEXT NODE: "Parent"

Gender: "Female"

NODE NAME: "Son"  
 LINE #: ANY  
 KEY WORDS: ["DUMU", "A", ...]  
 NEXT NODE: "Parent"

Gender: "Male"

NODE NAME: "Parent"  
 LINE #: ANY  
 KEY WORDS: []  
 NEXT NODE: "Parent Profession"

Parent: "{d}EN.ZU-i-mi-ti"

NODE NAME: "Profession"  
 LINE #: ANY  
 KEY WORDS: ...  
 NEXT NODE: ..





&P365160 = A000050 (Blocher

1992b,219-220)

#project: acawai

#atf: use unicode

#atf: lang akk

#atf: use math

#atf: use legacy

@tablet

@seal 1

#TA000050.01

1. KIŠIB a-ḫu-ši-na

#lem: kunukku[seal]N; Aḫušina[PN]

@seal 2

#TA000050.02

1. KIŠIB {d}UTU-na-šir

#lem: kunukku[seal]N; +Šamaš-našir[PNŠ]

@seal 7

#TS000220

1. {d}EN.ZU-en-n[am]

2. SANGA {d}UTU

3. DUMU {d}EN.ZU-i-mi-ti

4. ÌR É.BÁBBAR

1	Seal owner	[da]-da	Dada
2	Seal owner's profession	DAM.GAR <sub>3</sub>	merchant
3	Seal owner's patronymic/gender	DUMU/DUMU.MÍ du-du	son of Dudu
4	Seal owner's subordination/gender	ARAD/GÉME {d}nin-šubur	servant of the goddess Ninšubur

Set of rules

@seal 7

#TS000220

1. {d}EN.ZU-en-n[am]

2. SANGA {d}UTU

3. DUMU {d}EN.ZU-i-mi-ti

4. ÌR É.BÁBBAR

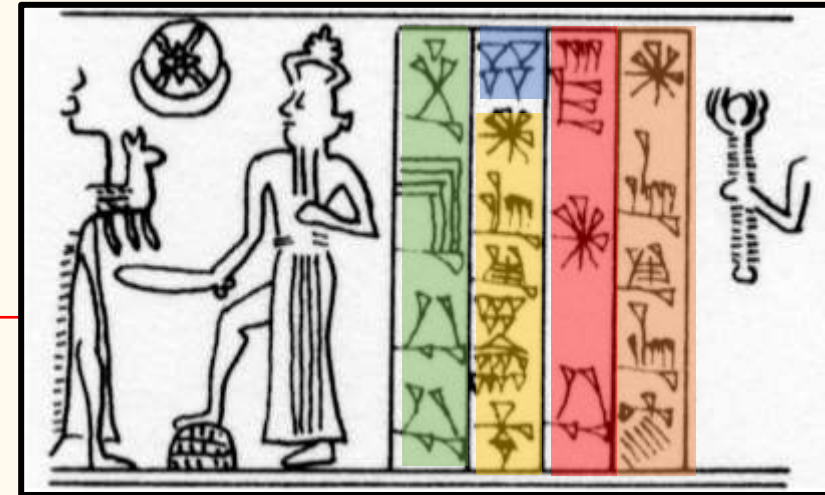

text-id	sealOwner	gender	parent	capacity	specification	superior
TS000219	{d}EN.ZU-en-nam	Male	{d}EN.ZU-i-mi-ti	SANGA	{d}UTU	É.BÁBBAR

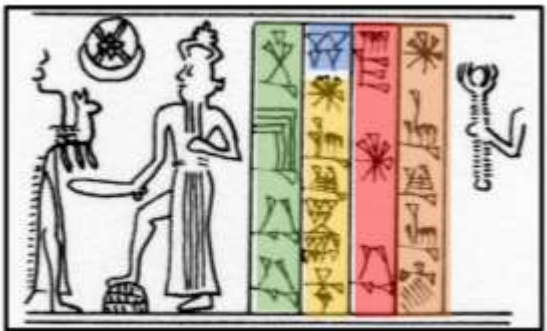

@seal 7  
#TS000220

- 1. {d}EN.ZU-en-n[am]
- 2. SANGA {d}UTU
- 3. DUMU {d}EN.ZU-i-mi-ti
- 4. ĩR É.BÁBBAR

text-id	sealOwner	gender	parent	capacity	capacity specification	superior
TS000219	{d}EN.ZU-en-nam	Male	{d}EN.ZU-i-mi-ti	SANGA	{d}UTU	É.BÁBBAR



```
@sense PN 1
@end entry

+@entry Sin-bel-ili [1] PN
@form {d}EN.ZU-be-el-i3-li2 %akk $Sin-bel-ili
@sense PN 1
@end entry

@entry Sin-ennam [1] PN
@form {d}EN.ZU-en-nam %akk $Sin-ennam
@sense PN 1
@end entry

@entry Sin-eribam [1] PN
@form {d}EN.ZU-e-ri-ba-am %akk $Sin-eribam
@sense PN 1
@end entry

@entry Sin-eriš [1] PN
@form {d}EN.ZU-URU %akk $Sin-eriš
@form {d}EN.ZU.URU4 %akk $Sin-eriš
@sense PN 1
@end entry

@entry Sin-gamil [1] PN
@form {d}EN.ZU-ga-mil %akk $Sin-gamil
@form {d}EN.ZU-ga-mi-il %akk $Sin-gamil
```

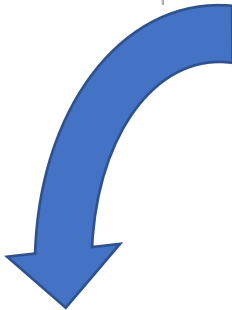

text-id	sealOwner	sO_POS	gender	parent	sOP_POS	capacity	capacity_specification	superior	sOS_POS
TS000219	Sin-ennam	PN	Male	Sin-imitti	PN	šangû (priest)	Šamaš	Ebabbar	TN

# Overview & Connections

## Counting divine names in seal inscriptions

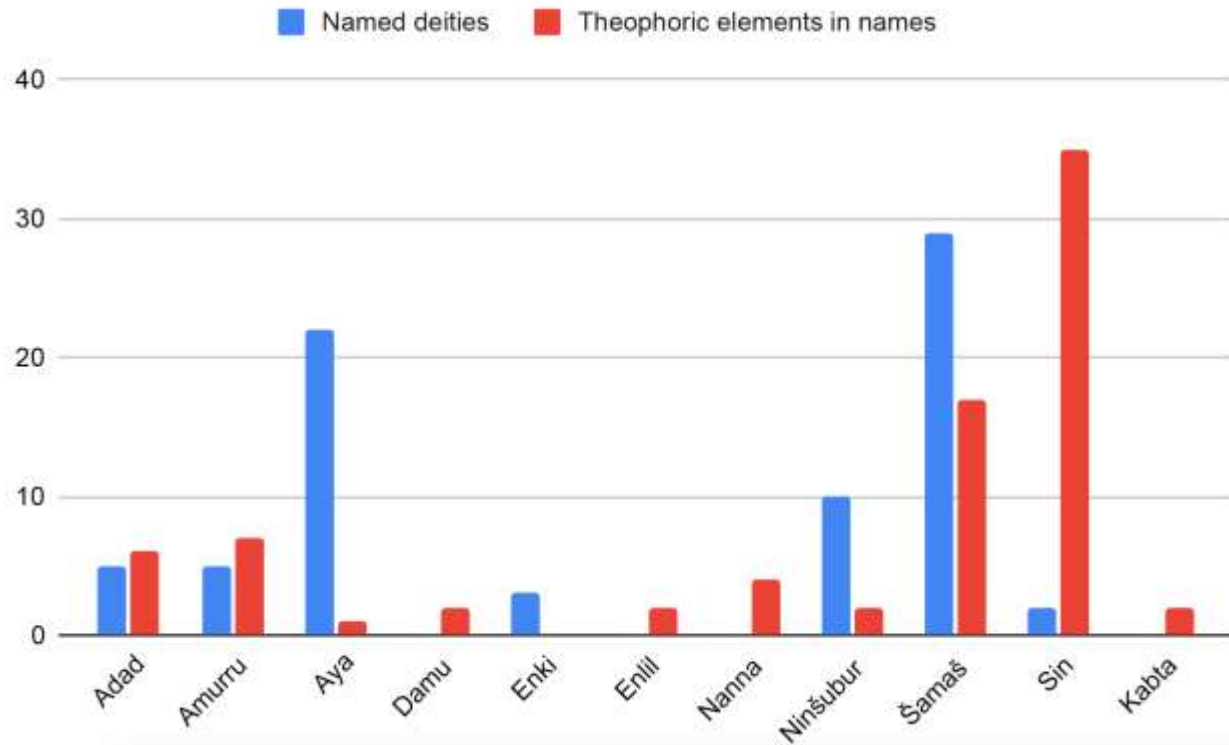

(total: 223)

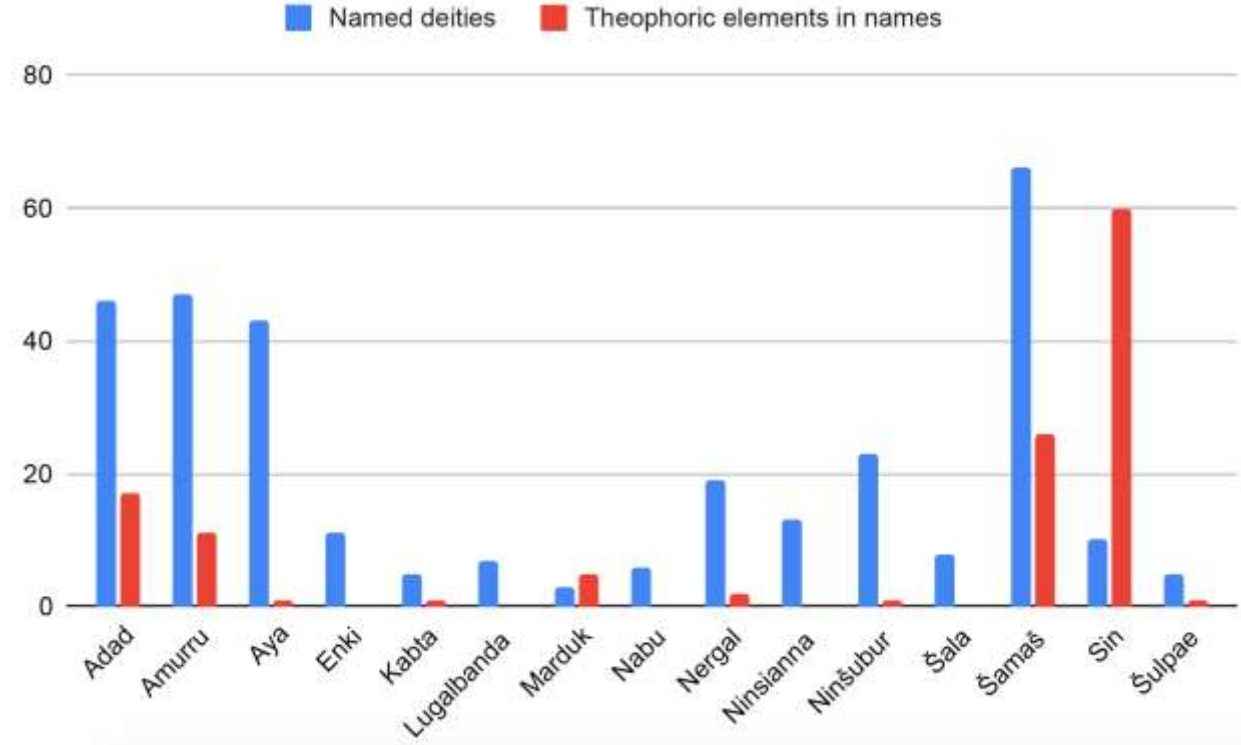

Collon, Dominique 1986. *Isin-Larsa and Old Babylonian Periods*. Catalogue of the Western Asiatic seals in the British Museum. Cylinder Seals 3. London.

Blocher, Felix 1992. *Siegelabrollungen auf frühaltbabylonischen Tontafeln in der Yale Babylonian Collection*. Münchener Vorderasiatische Studien 9. München and Wien.

# Overview & Connections

## Superiors named in the inscriptions

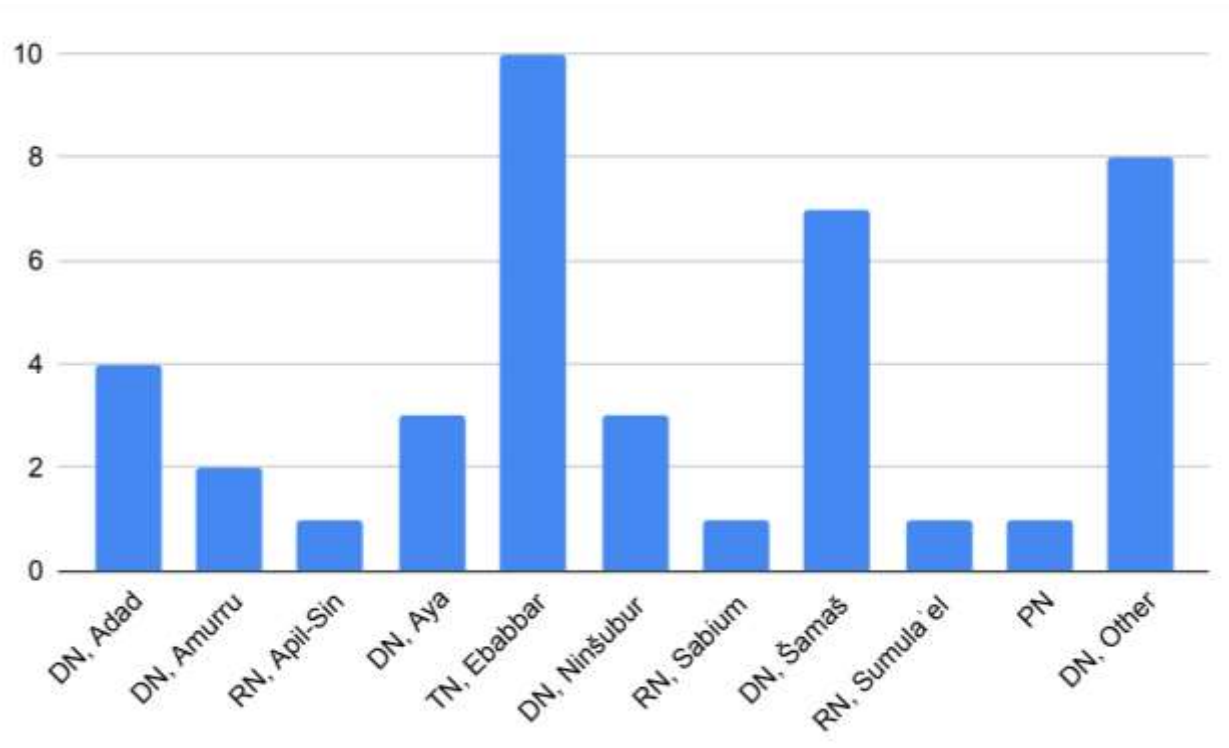

## Divine figures depicted

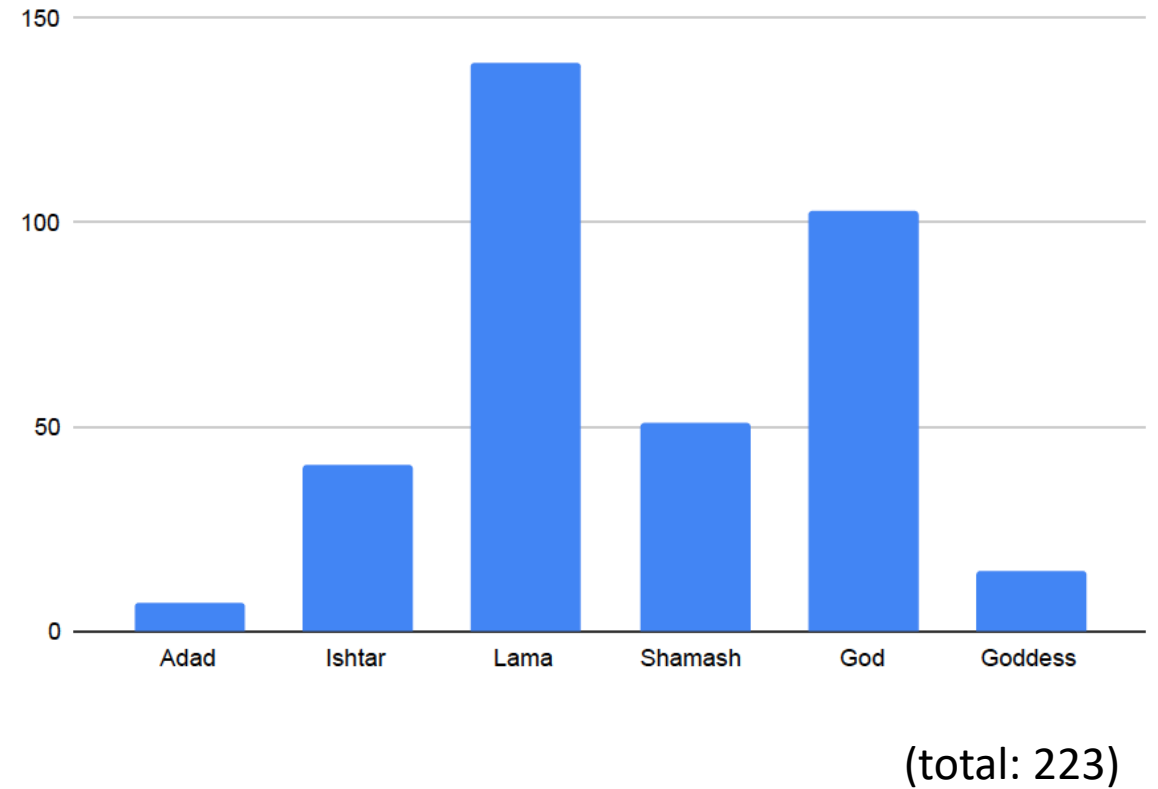

Blocher, Felix 1992. *Siegelabrollungen auf frühaltbabylonischen Tontafeln in der Yale Babylonian Collection*. Münchener Vorderasiatische Studien 9. München and Wien.

# Quantitative analysis

Interspersed visual elements in Old Babylonian seals

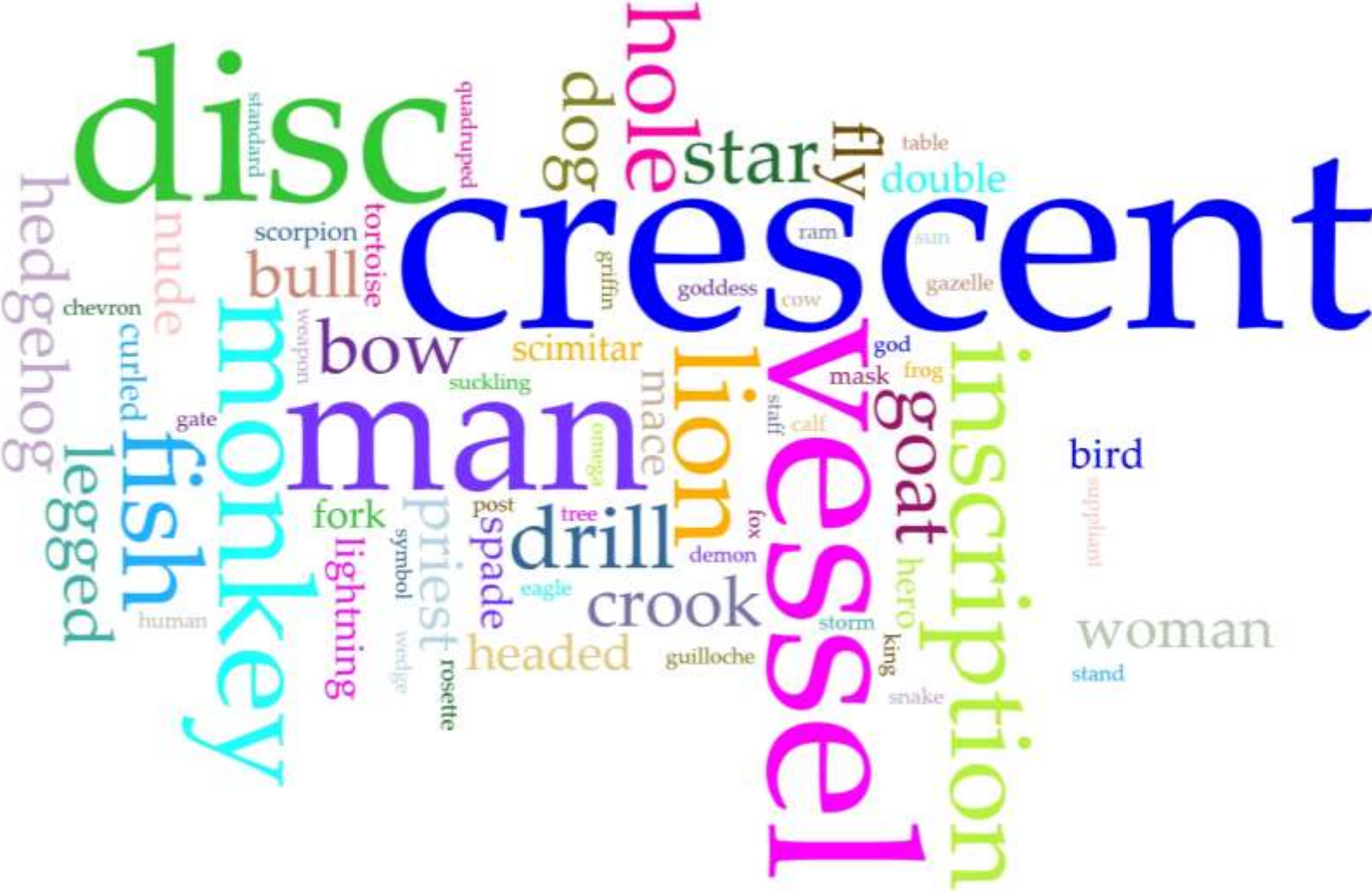

# Overview & Connections

<https://visualisierung.smb.museum/>

## VISUELLE EXPLORATION ZWEIER MUSEALER SAMMLUNGEN

Basierend auf Daten der Staatlichen Museen zu Berlin zeigt die Visualisierung über 5000 ausgewählte Objekte aus dem Bestand der Alten Nationalgalerie und dem Museum Europäischer Kulturen. Die Sammlungsobjekte—von Miniaturgemälden über Fotografien bis zu Alltagsgegenständen—eint der Entstehungszeitraum des 19. Jahrhunderts.



In der Wolke werden die Objekte nach Bildinhalten und Titelangaben algorithmisch angeordnet, so dass ähnliche Objekte nahe beieinander und unterschiedliche weiter auseinander liegen. Zur Orientierung sind die Gruppierungen mit Stichwörtern versehen, die händisch hinzugefügt wurden.

Zoomen Sie mit dem Touchpad oder Scrollrad in die Wolke hinein oder klicken Sie auf ein Stichwort oder Bild, um näher an die Objekte heranzukommen. Klicken und ziehen Sie den Hintergrund, um den Sichtbereich zu verschieben. Klicken Sie auf ein Objekt, um dessen Titel sowie besonders ähnliche Objekte durch Hervorhebung angezeigt zu bekommen. Klicken Sie auf den Titel des Objekts, um in die Pfadansicht zu gelangen.



In der Pfadansicht werden jene Objekte in einer Liste angezeigt, die einem ausgewählten Objekt ähneln oder einer Suchanfrage entsprechen. Die Ausschläge des Fadens zwischen den Objekten zeigen die abnehmende Ähnlichkeit an: Je größer der Ausschlag, desto weiter entfernt und somit unähnlicher ist das nächste Objekt zum oben ausgewählten Objekt.

Die Visualisierung entstand in enee

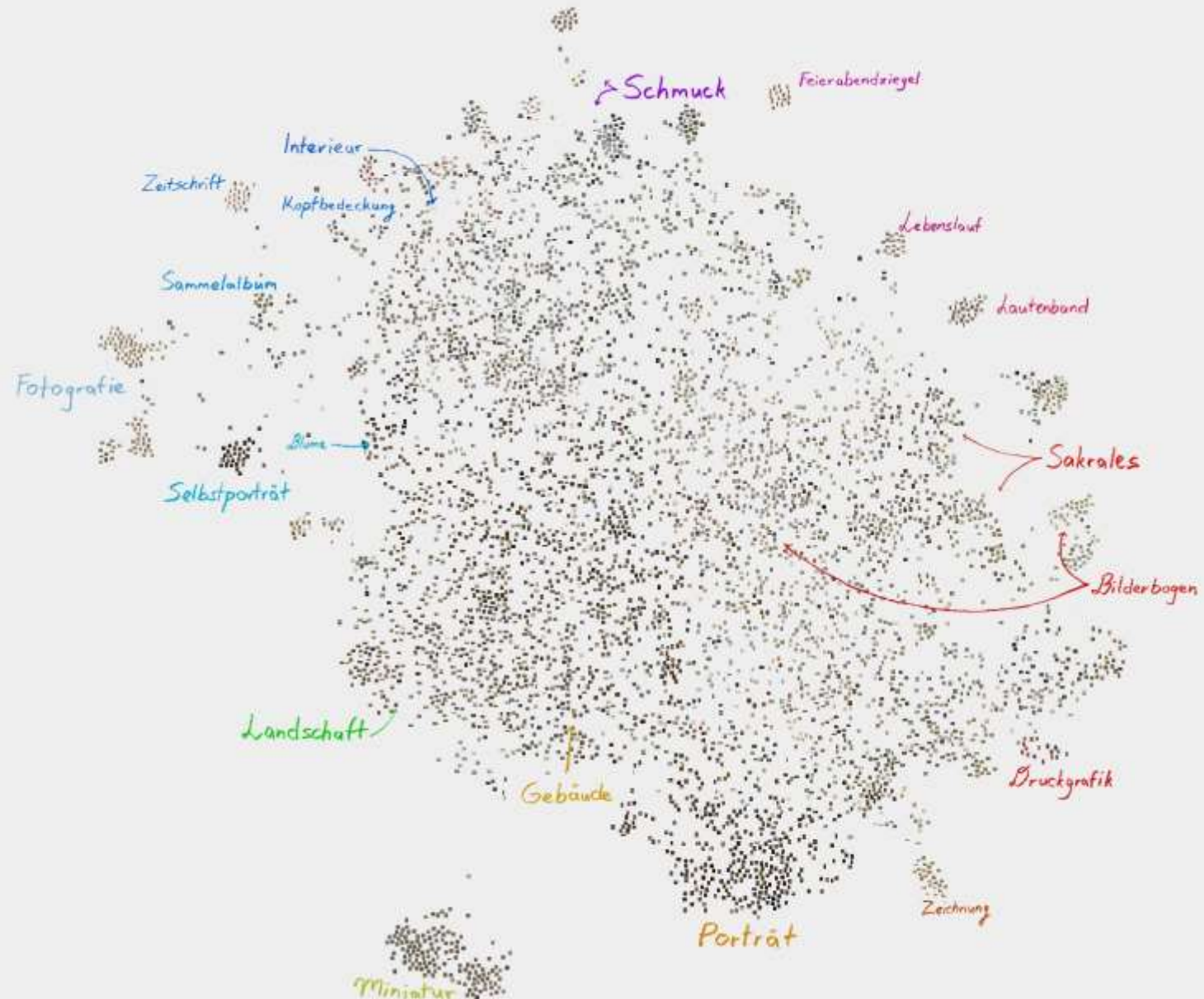

# Overview & Connections

<https://vikusviewer.fh-potsdam.de/fw4/vis/>

## VERGANGENE VISIONEN AUS DER FEDER VON FRIEDRICH WILHELM IV.

Die Visualisierung zeigt den Bestand historischer Zeichnungen von Friedrich Wilhelm IV. entlang einer thematischen und zeitlichen Einordnung.



Die **Stichwörter** stellen die häufigsten Themen in den Zeichnungen Friedrich Wilhelms IV dar. Klicken Sie auf die Stichwörter, um die Auswahl der Zeichnungen thematisch einzugrenzen.



Die **Zeichnungen** sind entlang einer Zeitleiste entsprechend ihrer Entstehungsjahre positioniert. Unter den Jahreszahlen befinden sich weitere historische und biographische Informationen.

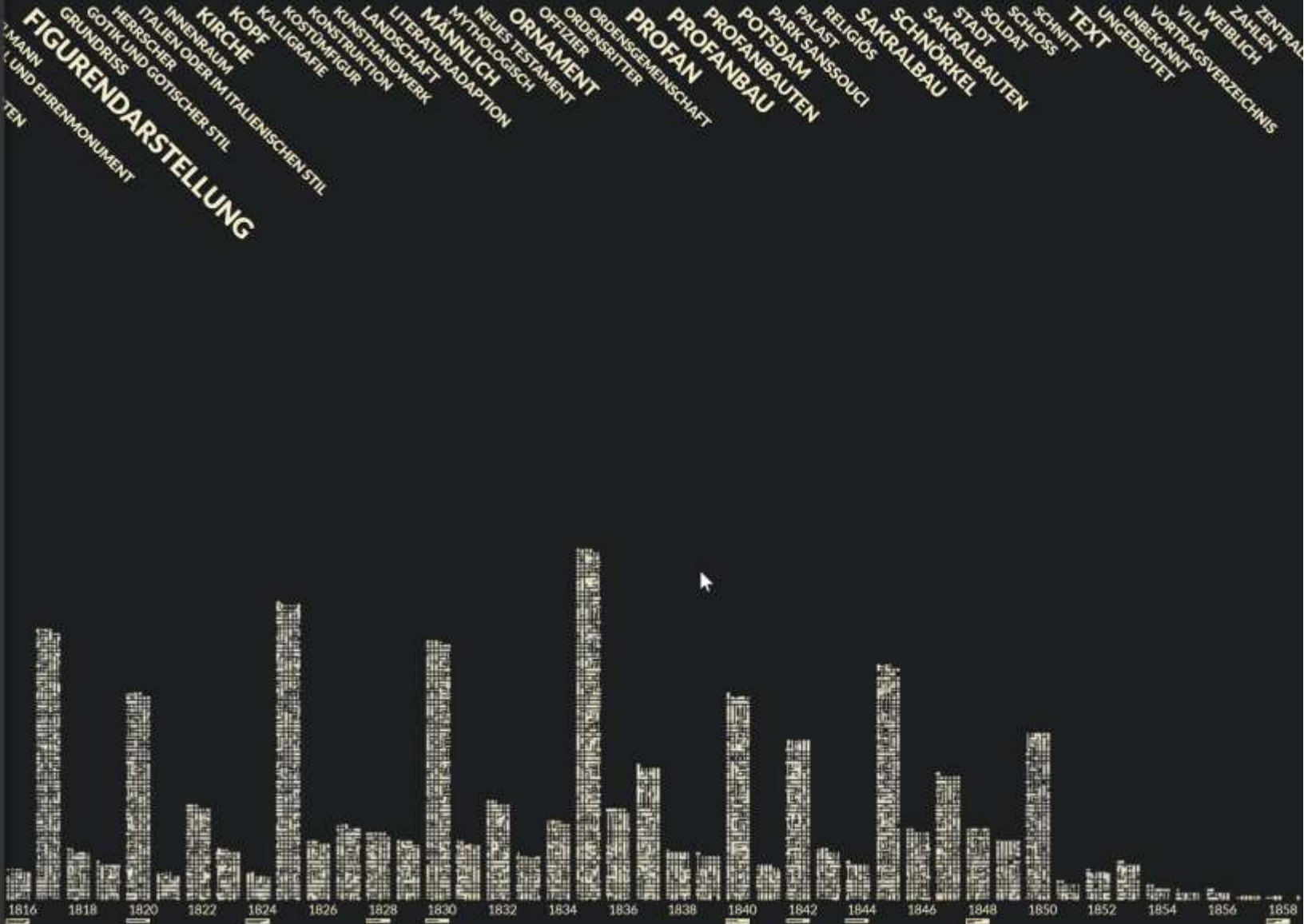

<https://uclab.fh-potsdam.de/coins/>

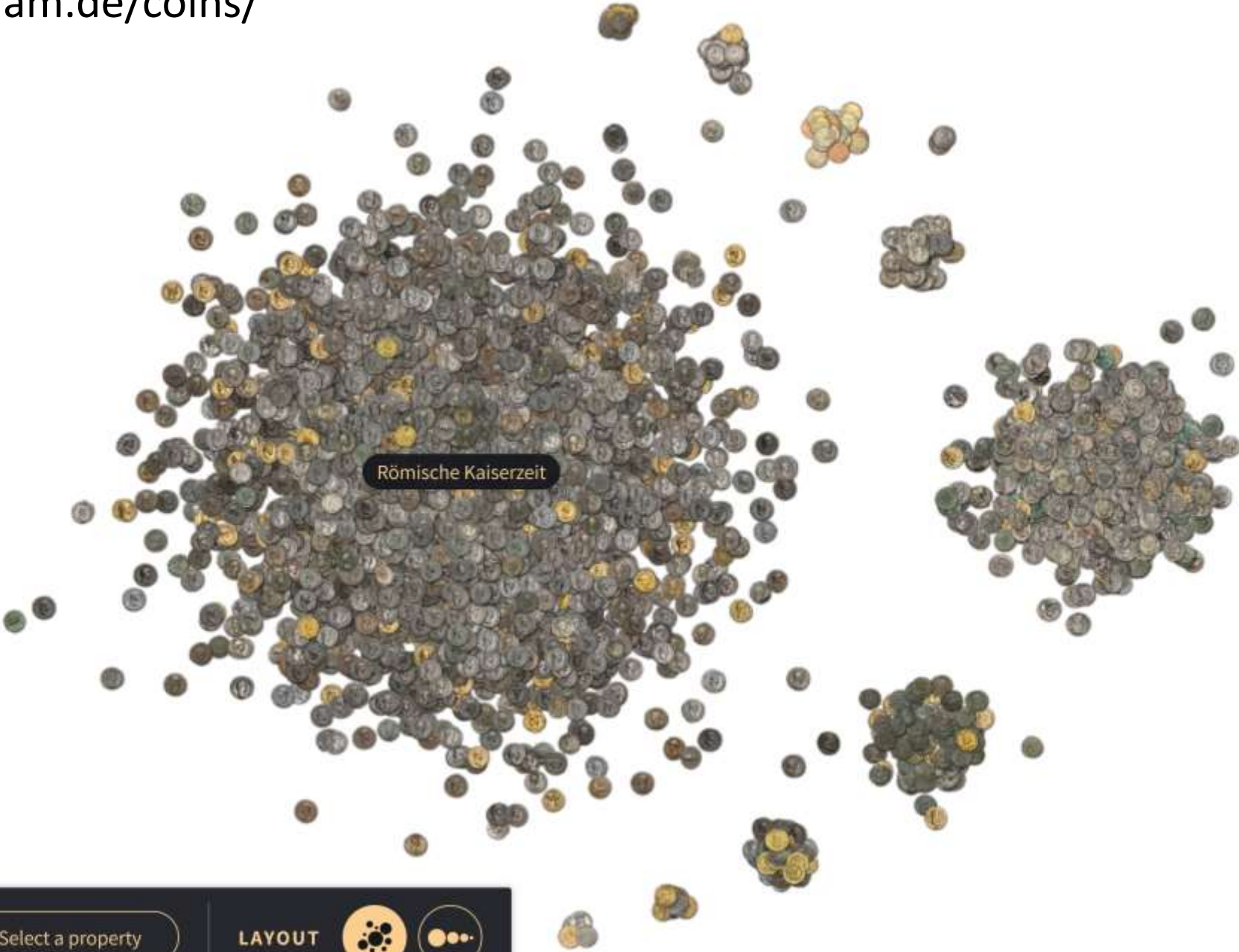

ORDER BY



Period



AND

Select a property

LAYOUT





# Network analysis with Gephi

## Combat scenes



al-Gailani Werr 1988, XXIV; 1 (167)

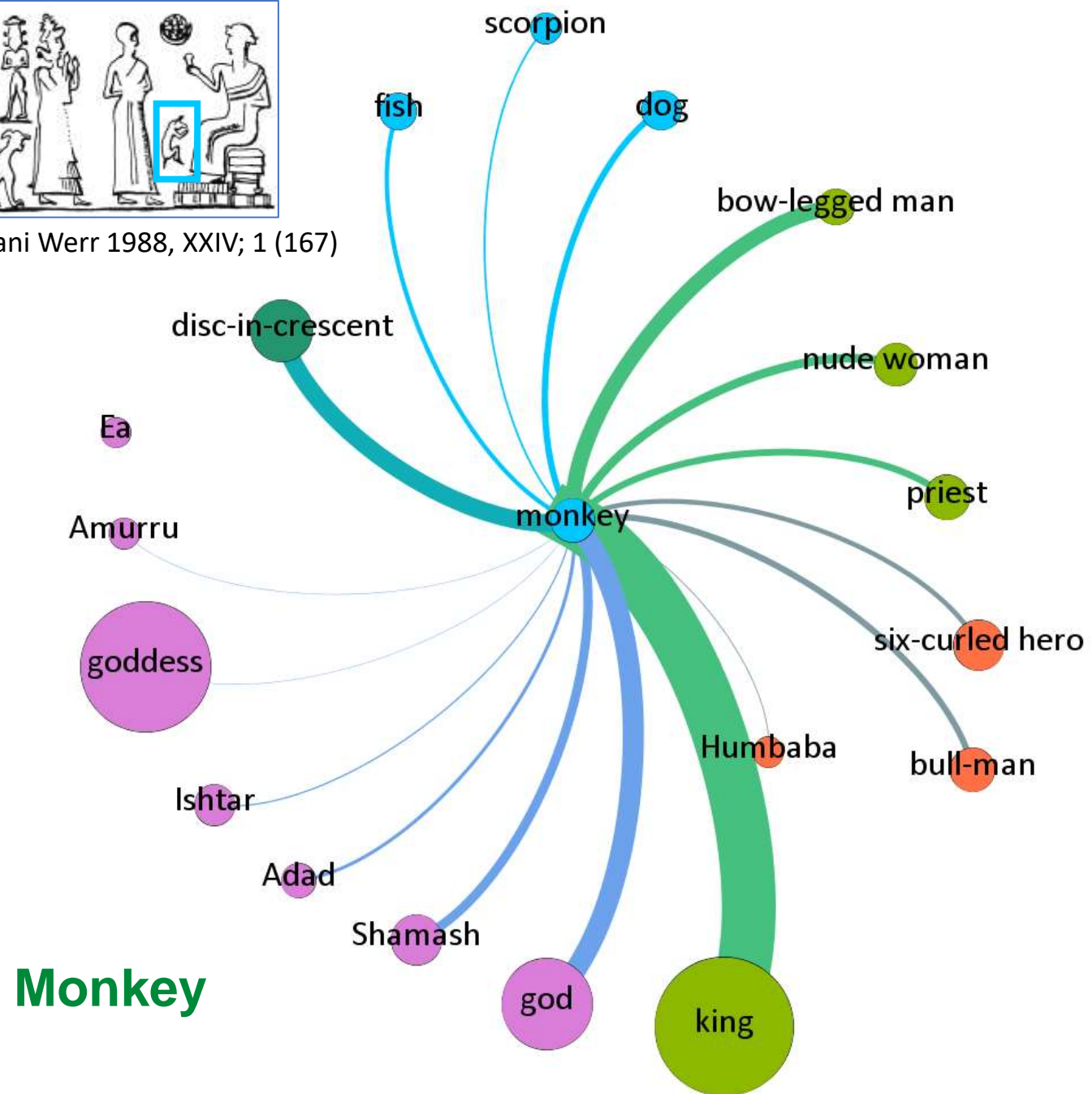
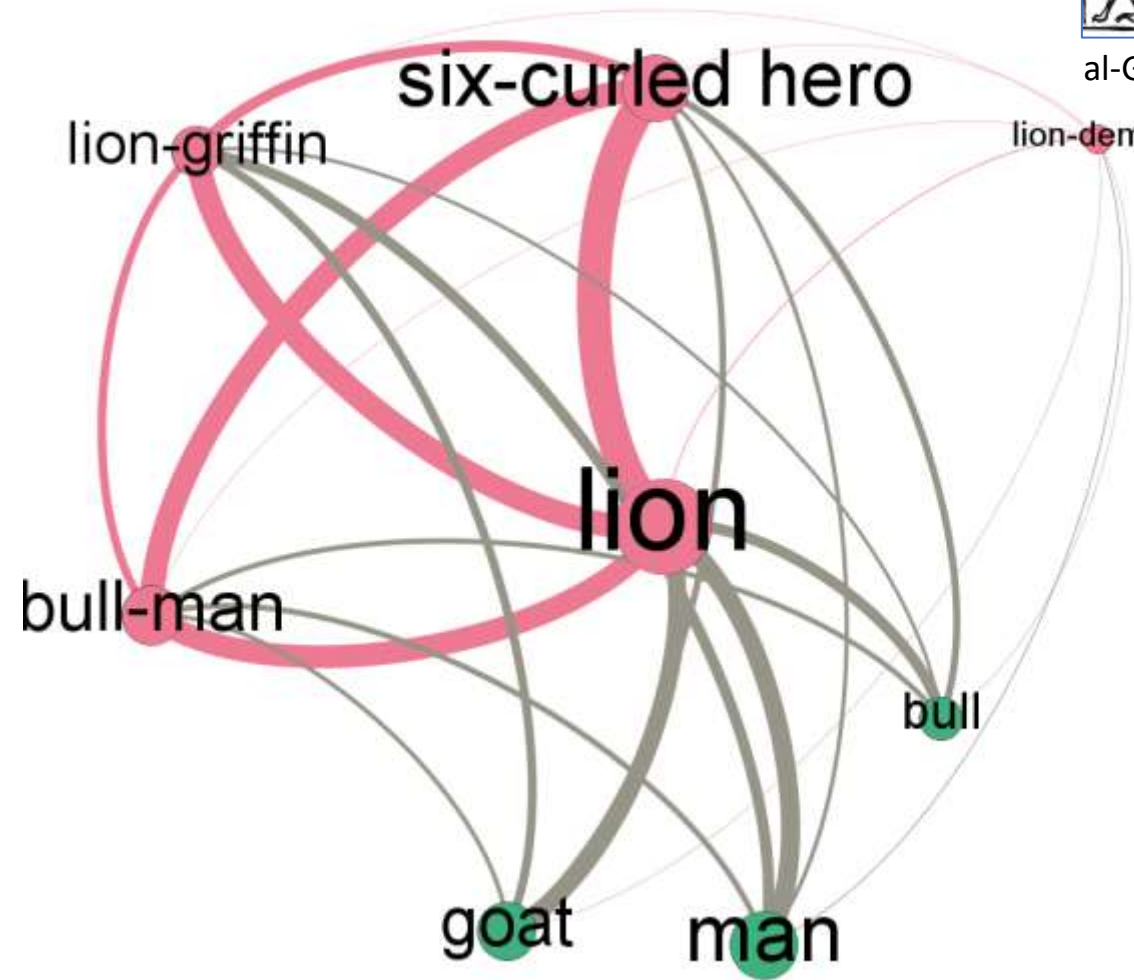

# Mappings

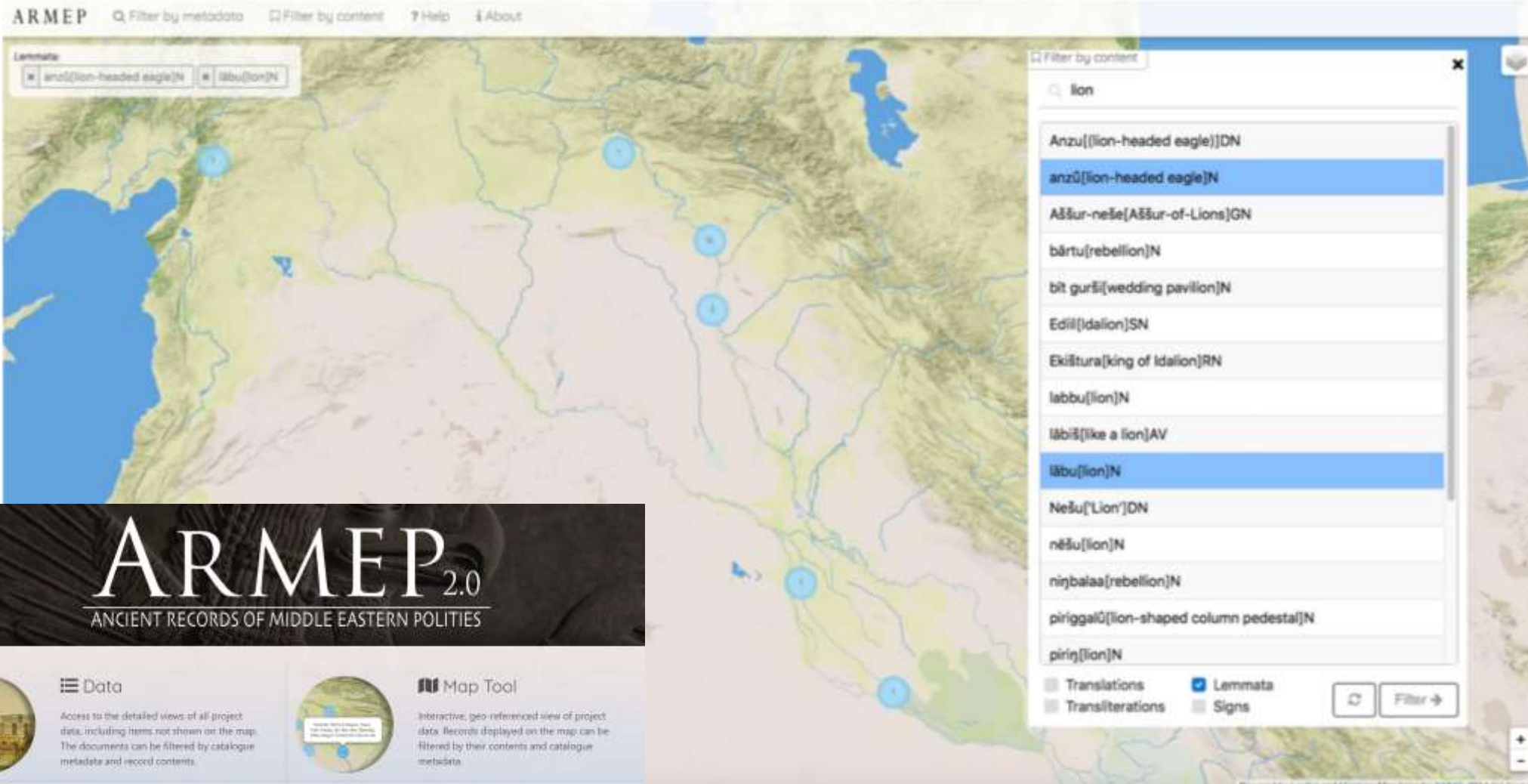

The screenshot shows the ARMEP web application interface. At the top, there are navigation links: "ARMEP", "Filter by metadata", "Filter by content", "Help", and "About". Below the navigation is a search bar with the text "Lemmata" and two dropdown menus containing "anzu[lion-headed eagle]N" and "läbu[lion]N". The main area is a map of the Middle East with several blue circular markers. On the right side, a "Filter by content" panel is open, showing a search for "lion". The results list includes: Anzu[([lion-headed eagle])DN], **anzû[lion-headed eagle]N**, Aššur-neše[Aššur-of-Lions]GN, bārtu[rebellion]N, bit guršî[wedding pavilion]N, Edii[Idalion]SN, Ekištura[king of Idalion]RN, labbu[lion]N, läbiš[like a lion]AV, **läbu[lion]N**, Nešu[‘Lion’]DN, nēšu[lion]N, niṅbaiaš[rebellion]N, piriggaš[lion-shaped column pedestal]N, and piriṅ[lion]N. At the bottom of the filter panel, there are checkboxes for "Translations", "Lemmata" (checked), "Transliterations", and "Signs".

**ARMEP<sub>2.0</sub>**  
ANCIENT RECORDS OF MIDDLE EASTERN POLITIES

- Data**  
Access to the detailed views of all project data, including items not shown on the map. The documents can be filtered by catalogue metadata and record contents.
- Map Tool**  
Interactive, geo-referenced view of project data. Records displayed on the map can be filtered by their contents and catalogue metadata.
- Documentation**  
Documentation of the REST - API along with an illustrated usage guide of the ARMEP interface and its core functionalities.
- About**  
ARMEP is a collaboration between LMU Geschichte and LMU Center for Digital Humanities. The dataset is derived from the Open Richly Annotated Coreform-Corpus.

<https://www.armep.gwi.uni-muenchen.de/#map>  
D. & T. Englmeier, J. Novonty, K. Radner (Oracc, MOCCI)

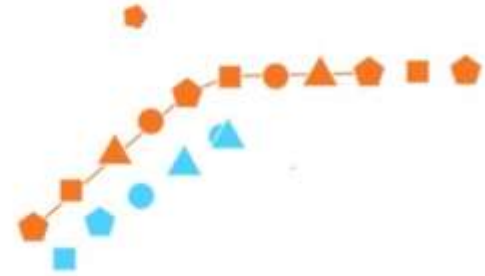
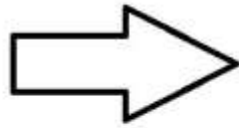
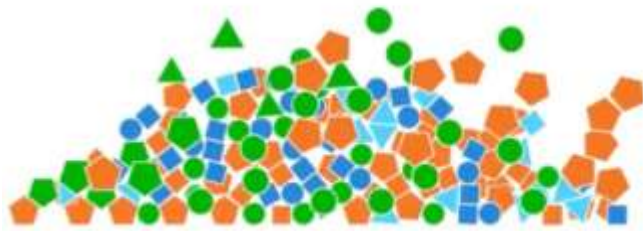

LMU • Institut für Vorderasiatische Archäologie • Elisa Roßberger



## Annotated Corpus of Ancient West Asian Imagery: Cylinder Seals (ACAWAI-CS)

A fantastic world of micro-pics — cut into stone, rolled onto clay, ready for Digital Humanities!



Objectives



Sources

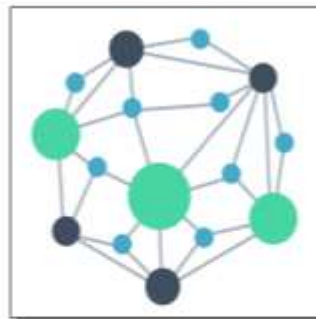

Approach



Blog



About