

DOI:

ABSTRACT

This paper presents overview on methods which is used for locating faults on the HVDC transmission lines. Different methods like Distance Protection Method, Discrete Fourier Transform (DFT), Hilbert-Huang Transform Method, Independent Component Method, Fuzzy Logic Method, Wavelet Transform (WT), Natural Frequency Method, Artificial Neural Network (ANN) etc are used. This paper provides the description of all methods.

KEYWORDS: Discrete Fourier Transform (DFT), Hilbert-Huang Transform Method, Wavelet Transform (WT), Artificial Neural Network (ANN).

INTRODUCTION

The number of high-voltage direct current (HVDC) systems is increasing rapidly throughout the world due to their advantages in long distance and large capacity power transmission, Fast and Flexible Control, Lower losses and asynchronous interconnections. These advantages make HVDC system more attractive than the HVAC system. The fault taking place on HVDC transmission Lines may Cause the instability of the power system and lead to a large economic loss. Quickly indentifying the faults can prevent the destruction of power system stability [1]. Distance relaying Principle, due to their high speed fault clearance compared with the over current relays is a widely used protective scheme for the protection of HVDC transmission line. A distance relay estimates the electrical distance to the fault and compares the result with given threshold, which determines the protection zone [2].

The traditional protection system for the HVDC transmission line often uses the voltage and its change rate to detect a ground fault in the dc line. But it is sensitive to fault impedance. With the rapid advance of microelectronics technology and microcomputer protections, traveling wave theory has been implemented and adopted in HVDC transmission lines successfully. But it has disadvantages such as it is easily affected by noise, difficulty in accurate detection of wave head, requirement of complex and expensive equipments cannot be implemented automatically by computers, vulnerable to interference of external signals etc [1]. Modern numerical relays generally use discrete Fourier transform for extracting the fundamental component from the post fault signals consisting of fundamental as well as non-fundamental frequency signals [3].

The synchronized measurement technology emerged as a promising prospect in achieving real time protection with global positioning system (GPS). The phasor measurements units (PMU) are the most widely used synchronized measurement devices for power system applications, whose measurements are synchronized with respect to a GPS clock and PMU based fault locators are more accurate than the methods based on unsynchronized phasors. There is a need for the measuring algorithms that have the ability to adapt dynamically to the system operating conditions such as changes in the system configuration, source impedances and fault resistances. Keeping this in view the intelligent techniques are under investigation to increase reliability, speed and accuracy of existing system based on Artificial Neural Network (ANN), Fuzzy Logic and Wavelet Methods [6].

EXISTING METHOD

Different researchers are used different methods in this era and gets different result. Following are the some methods which are used in the existing system.

2.1 Distance Protection Method

The proposed method is based on the frequency dependent nature of the line parameters. Hence, by considering frequency dependent parameter line model transformation matrix is separated into two parts (1) Constant parameter model known as distributed parameter model (2) Compensation matrix consisting of frequency dependent parameters [2].

Determination of fault location is necessary to distinguish whether the fault is internal or external to protection zone, especially for the end zone faults. Therefore, in distance protection some degree of measurement error is acceptable as relay will operate only when the fault lies in the protection zone and if the measured fault distance is not more than the setting distance. The condition for protection method to operate correctly is that the measurement error in the location of fault should be less than the difference between the fault distance and setting distance that is given as, $E_m < |I_f - I_{set}|$ (1)

where, E_m is the measurement error, I_f and I_{set} is the fault distance and the setting distance respectively.

This method is based on the accuracy of calculation of setting point voltage and current using frequency dependent parameter model. It reduces the error in the measurement of distance to a greater extent for far end faults.

2.2 Discrete Fourier Transform (DFT)

DFT Algorithm The most commonly used method of calculating phasors from sampled data is that of Discrete Fourier Transform (DFT). It is performed by the implementation of following equation,

$$X_k = \frac{\sqrt{2}}{N} \sum_{n=0}^{N-1} X(n) e^{-\frac{j2\pi kn}{N}} \dots\dots\dots(2)$$

In this equation, 'X' is the phasor of a signal, 'k' is the order of harmonic, 'x' is the instantaneous value of sinusoidal signal such as voltage and current, 'n' is the nth sample of data window and 'N' is the number of samples in data window. Recursive implementation of DFT is a more computationally efficient method which computes the estimated phasor recursively by adding the contribution made by the new sample, and subtracting the contribution made by the oldest sample. Phasor Measurement Units, which are being deployed on power systems as a measurement tool in many countries, use recursive DFT algorithm [3].

2.3 Hilbert-Huang Transform Method

Hilbert Huang transform is a new signal processing method, which has. By using Hilbert Huang can adapt decomposition in the time domain according to the signal itself. There is no function and decomposition scale selection problem. The Hilbert Huang transform can be applied to the travelling wave protection of a high-voltage direct current transmission; by analyzing the wave form, combined with comprehensive criterion such as the low voltage DC lines, it forms a new scheme of DC transmission line travelling wave protection. the EMD decomposition should consider the envelope fitting problems on the endpoint and decomposition, which should be improved by the algorithm; and we should use cubic spline interpolation to fit and extreme mirror continuation to eliminate endpoint effects [4,5].

2.4 Independent Component Method

Independent component analysis is a kind of high efficient blind source separation method that is developed gradually in recent years. The independent component analysis has been widely used in the feature extraction and the speech recognition aspects due to the little requirement of the environment and the target. we can use Fast Independent Component analysis to blind separate the DC voltage and DC current signal that are measured by multi-channels so that the system fault source signal is restored, and the key feature of this method can effectively extract the fault. Due to Independent component analysis algorithm, we can process the current signal of DC transmission lines after fault, then decompose the current characteristic signal, and finally detect the time of the initial Bob and the second arrive Bob measurement point and polarity relationship, so we can realize fault location. The constraints of an independent component method mainly require that source signals are independent each other, and there is a Gaussian signal at most [4].

2.5 Natural Frequency Method

Since DC transmission line is only a route, and thus we can extract a natural frequency method to realize fault locations. It proposes that there is a mathematical relationship between the fault travelling wave spectrum of transmission line and the fault distance, and a fault travelling wave spectrum can be used to realize a fault location.

Based on travelling wave natural frequency range of the principle component, this method isn't restricted by the Bob recognition; using transient voltage information after the line occurred in fault, through the spectrum analysis, we can get the natural frequency of the travelling wave principle component, and we can realize a fault location. Using the data on both ends of the line, the Pronny algorithm is utilized to extract the wave natural frequency; we can't use line parameters to calculate the wave velocity, but we can realize a precise fault location. Integration testing model decomposition is used to extract the high frequency component of the wave, identify the Bob and extract the precise time parameter, and finally solve the problem of wave velocity selection [4].

2.6 Artificial Neural Network

The reach accuracy of an electromechanical, static or a microprocessor based distance relay is affected by different fault conditions and network configuration changes. So ANN techniques are under investigation over the past 15-20 years, which can adapt dynamically to the system operating conditions at a high speed. The ability of ANN to learn by training any complex input/output mapping and recognize the noisy patterns gives them the powerful property of pattern recognition and classification. ANNs can solve the overreach and the under reach problems which are very common in the conventional distance relay design. ANN utilizes samples of currents and voltages directly as inputs without computation of phasors and related symmetrical components. Various kinds of neural network such as multi-layer perceptron (MLP), recurrent, radial basis function (RBF), probabilistic neural network etc. are being applied for fault classification and fault location. These are designed by different training algorithms like back propagation, orthogonal least square, extended kalman filter etc. The use of ANNs can extend the first zone of distance relays and enhance system security. For selecting the appropriate network configurations, the performance criteria are fault tolerance, minimal response time and generalization capabilities. ANN approach has been used to improve some of the standard functions used in protection of transmission lines. They have been related to fault direction discrimination, fault detection and classification, distance protection, improvements in fault distance computation, protection of series compensated lines, adaptive distance protection and adaptive reclosing [6,7].

To make the ANN responsive to time varying voltage and current waveforms different types of recurrent networks were considered that allow the hidden units of the network to see their own previous output, so that the subsequent behavior can be shaped by previous response. Such an Elman recurrent network designed to act as the fault direction detection module of a transmission line. Further development is the concept of supervised clustering to reduce the number of iterations in the learning process of multi layer feed forward networks. It is observed that the ANN based distance relays need much larger training sets and hence the training of these networks is time consuming and further research work shall produce a hardware realization with proper modification in the learning methodology and preprocessing of input data that would improve the learning rate performance, efficiency and the reliability many folds. Presently research efforts are in the direction of evolutionary computational techniques such as genetic algorithms (GA) for determining the neural network weights and thereby avoid training of ANN [8].

2.7 Fuzzy Logic Method

Zadeh introduced the concept of fuzzy set theory in 1965 for dealing with uncertain and ambiguous properties of events (Zadeh, 1965). It was introduced in power system networks to solve uncertainty problems that arise due to the continuously varying power system parameters. The key benefit of fuzzy logic is that its knowledge representation is explicit, using simple "IFTHEN" relations. The fuzzy set theory is used for fault type identification on a transmission line. These algorithms are fairly accurate only under certain assumptions of fault distance, pre-fault power flow, fault resistance and line length [6].

Design of a fuzzy logic controller does not need an accurate mathematical model of the system under consideration. A qualitative knowledge about the system behavior is adequate to design a fuzzy logic controller to achieve a desired control objective. In addition, it is easy to add expert / heuristic knowledge about the system behavior in the controller structure. Moreover, the performance of a fuzzy logic controller is not significantly affected due to changes in system operating conditions and parameters. The output of Fuzzy Logic Controller can be utilized to modulate the power order of the DC control, which in turn modulates the DC power. The stabilizing control is implemented through large signal modulation of power in response to a control signal derived from the AC system variables. The effectiveness of the control can be enhanced by increased overload rating of the converters which permit short-term overloads [9].

In fuzzy logic based protection system, accuracy cannot be guaranteed for wide variations in system conditions. So consequently a more dependable and secure relaying algorithm during real time implementation is needed for classifying the faults under a variety of time-varying network configurations. The fuzzy-neuro approaches are

sensitive to system frequency changes and require large training sets and a large number of neurons affecting their accuracy and speed in protecting large power networks [10].

2.8 Wavelet Transform

Wavelet analysis is a relatively new signal processing tool and is applied recently by many researchers in power system due to its strong capability of time and frequency domain analysis [11].

The definition of continuous wavelet transform (CWT) for a given signal $x(t)$ with respect to a mother wavelet $\phi(t)$ is,

$$CWT(a,b) = \frac{1}{\sqrt{a}} \int_{-\infty}^{\infty} X(t) \phi\left(\frac{t-b}{a}\right) dt \quad (3)$$

Where a , is the scale factor and b is the translation factor. For CWT, t , a , b are all continuous. Unlike Fourier transform, the wavelet transform requires selection of a mother wavelet for different applications. One of the most popular mother wavelets for power system transient analysis found in the literature is Daubechies's wavelet family. In the new scheme, the db5 wavelet is selected as the mother wavelet for detecting the short duration, fast decaying fault generated transient signals.

The application of wavelet transform in engineering areas usually requires discrete wavelet transform (DWT), which implies the discrete form of t , a , b eqn. The representation of DWT can be written as:

$$DWT(m,n) = \frac{1}{\sqrt{a_0^m}} \sum_k X(k) \phi\left(\frac{k - nb_0 a_0^m}{a_0^m}\right) \quad (4)$$

Where original a and b parameters in equation are changed to be the functions of integers m , n . k is an integer variable and it refers to a sample number in an input signal. A very useful implementation of DWT, called multiresolution analysis, is demonstrated in Fig. below. The original sampled signal $x(n)$ is passed through a high pass filter $h(n)$ and a low pass filter $l(n)$. Then the outputs from both filters are decimated by 2 to obtain the detail coefficients and the approximation coefficients at level 1 (D1 and A1). The approximation coefficients are then sent to the second stage to repeat the procedure. Finally, the signal is decomposed at the expected level.

Figure 1: Idea of wavelet multi-resolution analysis

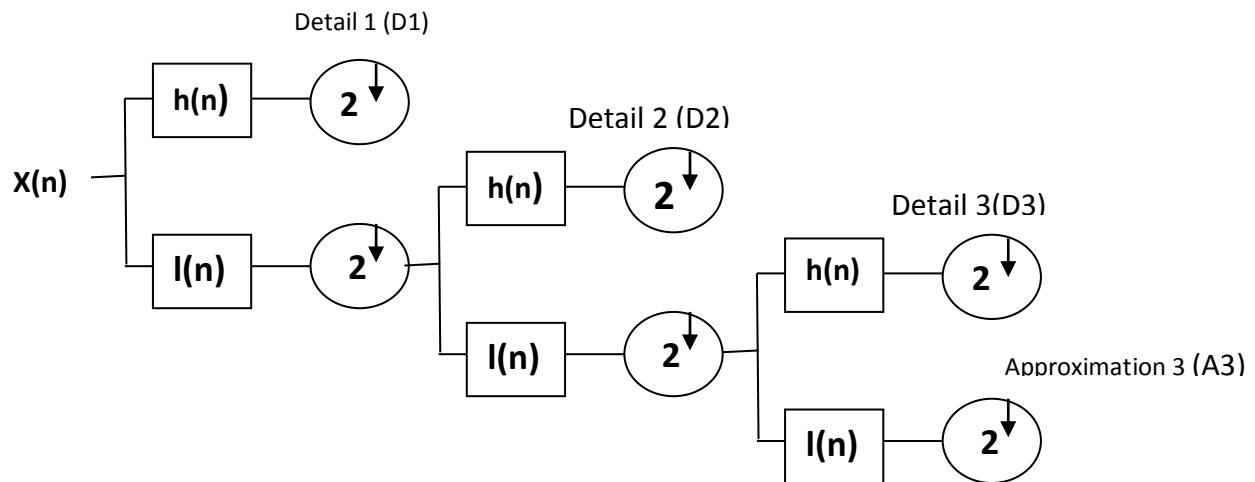

In the case shown in Fig.(1), if the original sampling frequency is F , the signal information captured by D1 is between $F/4$ and $F/2$ of the frequency band. D2 captures the information between $F/8$ and $F/4$. D3 captures the information between $F/16$ and $F/8$, and A3 retains the rest of the information of original signal between 0 and $F/16$. By such means, we can easily extract useful information from the original signal into different frequency bands and at the same time the information is matched to the related time period. An example, given in Fig., illustrates the procedure. The original signal is one cycle of a post-fault current signal, as shown in Fig. We use db5 wavelet to make a 5 level decomposition. The reconstructed versions of each detail and the approximation are shown in Fig. The information of original signal is clearly represented at each frequency band. The original signal can be

reconstructed by adding up those wavelet signals at the same sample point. The wavelet tool box in MATLAB provides a lot of useful techniques for wavelet analysis.

CONCLUSION

In the HVDC system, long-distance transmission and complex environment are the main factors which are responsible for fault occurrence. Hence the Transmission Line Protection is must be done to stop the faults occurs in the HVDC system. This paper provides the overview of different methods used by the different researchers.

REFERENCES

- [1] Zheng Xiao-Dong, Tai Neng-Ling, James S. Thorp, and Yang Guang-Liang, "A Transient Harmonic Current Protection Scheme for HVDC Transmission Line", IEEE TRANSACTIONS ON POWER DELIVERY, VOL.27,NO.4,OCTOBER2012.
- [2] Ruchita Nale & Suresh Babu, "Distance Protection of HVDC Transmission Line with Novel Fault location technique", IJRET,2014.
- [3] V.S.Kale , S.R.Bhide & P.P.Bedekar, "Comparison of Wavelet Transform and Fourier Transform based methods of Phasor Estimation for Numerical Relaying", International Journal of Advances in Engineering Sciences Vol.1, Issue 1,2011.
- [4] LIANG Wen-li and SHANG Li-qun," The Review of High Voltage DC Transmission Lines Fault Location", International Journal of Computer, Consumer and Control (IJ3C), Vol. 3, No.4, 2014.
- [5] Jing Liu, Jiandong Duan, Hailong Lu and Yuanbing Sun, "Fault Location Method Based on EEMD and Traveling-Wave Speed Characteristics for HVDC Transmission Lines", Journal of Power and Energy Engineering, 2015.
- [6] Kola Venkataramana Babu, Manoj Tripathy and Asheesh K Singh," Recent techniques used in transmission line protection: a review", International Journal of Engineering, Science and Technology, Vol. 3, No. 3, pp. 1-8, 2011.
- [7] Sanjay Kumar K , Shivakumara Swamy.R and Dr. V. Venkatesh, "Artificial Neural Network Based Method for Location and Classification of Faults on a Transmission Lines", International Journal of Scientific and Research Publications, Volume 4, Issue 6, June 2014.
- [8] Anamika Yadav and A.S. Thoke, "ANN Based Directional Fault Detector/Classifier for Protection of Transmission Lines", International Journal of Computer Science and Information Technologies, Vol. 2 (5) , 2011.
- [9] M. Sarvi and M. Keshmiri, "A Fuzzy-PD Controller to Improve the Performance of HVDC System", World Appl. Sci. J., 22 (9): 1210-1219, 2013.
- [10]Uma Vani Marreddy , Ramana Rao P.V. and Jayaram Kumar S.V.," Fuzzy Logic Controller for Enhancement of Transient Stability in Multi Machine AC-DC Power Systems", IACSIT International Journal of Engineering and Technology, Vol.2, No.5, October 2010.
- [11]MukeshThakre, Suresh Kumar Gawre & Mrityunjay Kumar Mishra, "Distribution System Faults Classification And Location Based On Wavelet Transform", International Journal on Advanced Computer Theory and Engineering, 2319 – 2526, Volume-2, Issue-4, 2013.