

JEL Classifications: M 11, Q 56

Sviatoslav KNIAZ

Doctor of Economic Sciences, Professor

Lviv Polytechnic National University, Lviv, Ukraine

ORCID: <http://orcid.org/0000-0002-7236-1759>

Olha ZAIATS

PhD, Associate Professor

Lviv State University of Internal Affairs, Lviv, Ukraine

ORCID: <http://orcid.org/0000-0003-2872-5567>

Oksana SHAYDA

PhD, Associate Professor

Lviv Polytechnic National University, Lviv, Ukraine

ORCID: <http://orcid.org/0000-0003-1666-0436>

Tetyana DANKO

PhD, Associate Professor

Lviv Polytechnic National University, Lviv, Ukraine

ORCID: <http://orcid.org/0000-0001-7342-4830>

Natalia BAIDALA

PhD, Associate Professor

Lviv Polytechnic National University, Lviv, Ukraine

ORCID: <http://orcid.org/0000-0002-3272-9600>

Nina MEREZHKO

Doctor of Technical Sciences, Professor

Kyiv National University of Trade and Economics, Kyiv, Ukraine

ORCID: <http://orcid.org/0000-0003-3077-9636>

Oleh KOTSIUMBAS

PhD, Associate Professor

Lviv Polytechnic National University, Lviv, Ukraine

ORCID: <http://orcid.org/0000-0002-6590-4022>

Halyna LEMA

PhD, Associate Professor

Lviv Polytechnic National University, Lviv, Ukraine

ORCID: <http://orcid.org/0000-0001-5298-7693>

Iryna PROTYSYK

PhD, Associate Professor

Lviv Polytechnic National University, Lviv, Ukraine

ORCID: <http://orcid.org/0000-0002-6370-1344>

Olesya HOLOVINA

PhD, Associate Professor

Odessa State Environmental University, Odessa, Ukraine

ORCID: <http://orcid.org/0000-0002-1391-5731>

DEVELOPMENT OF ENVIRONMENTAL MANAGEMENT SYSTEM BY INDUSTRIAL ENTERPRISES

Annotation. *The article reveals the essence of methodological and applied recommendations for the development of environmental management systems of industrial enterprises. As a result of the study, the structure of the environmental management system is clarified, alternative options for modeling the development of this system are considered, and the stages of formation of the environmental potential of the enterprise are highlighted.*

Keywords: *system, development, environmental activities, environmental potential, environmental needs of society, environmentally friendly products.*

1. Introduction

Over the past few decades, the relevance of implementing the sustainable development concept provisions has been constantly increasing. The goals declared by the concept oblige industrial enterprises to be responsible to a society and future generations for the impact on the environment, the rational use of natural resources, as well as the safety of goods offered on the market. Since environmental problems are global in nature, despite the fact that not all industrial enterprises are large business structures and operate in limited, local areas, all of them are obliged to develop environmental management systems. Because of the instability of the external environment and the increasing challenges, environmental management system environmental activities require a regular improvement. To accomplish this task, the managers of these enterprises must have a high level of personal and corporate responsibility for approved decisions. An important aspect of the effectiveness of management and engineering decisions in the field of environmental protection is also the awareness of management entities, their creativity and willingness to innovate. These factors recognize the environmental potential of the enterprise and its role in meeting public environmental needs.

2. Review of previous studies

Among the modern researches devoted to problems of developing management systems of the enterprise environmental protection activity, it is advisable to allocate some vectors. The first is the research, in which the enterprise is considered as an element of the sustainable development system, which requires permanent adaptation to the environment [1], as well as the construction of the management system that would ensure only those changes that do not harm future generations [2]. The second is the research, which focuses on the enterprise social responsibility [3], in particular, the corporate, environmental one [4]. In this direction it is necessary to allocate the scientific works devoted to such problems as: search of balance between the managing subjects' satisfaction of economic interests [5] and the society ecological needs [6]; ecological risks [7], ecological safety [8, 9] and administrative and legal mechanisms of its providing [10]. The third is the research, in which the society environmental needs are considered in the context of a separate consumer niche [11]. It is about environmental challenges for economic entities [12], as an objective circumstance that requires

technological innovation [13] and environmental management systems improvement [14], in particular, the systems' development through the use of universally recognized, transparent mechanisms [15]. This group of studies should include the works in which environmentally friendly products are considered as a competitive advantage [16]. Among these and other scientific works [17–35], the structure of environmental management systems of enterprises is considered only in fragments, which is the reason for the imperfection of their development models in the context of the concept provisions of the sustainable development.

3. Purpose, objectives and research methods

The article's purpose is to form methodological and applied recommendations for developing environmental management systems of enterprises (EMSE). It is necessary: to clarify the EMSE structure (while doing this task a rigid structural scientific methodological approach and method of synthesis are applied); to consider alternative options for modeling the EMSE development and allocate the stages of forming the enterprise ecological potential as a set of features that are the basis for the EMSE development (while doing this task a systemic process scientific methodological approach as well as a set theory tools, in particular the set of Zermelo-Fraenkel axioms are applied).

4. Results and discussion

4.1. The EMSE structure

The EMSE is an open, artificial, managed system. Its formation is based on the organizational, individual and collective goals of the management entities, which are consistent with social needs, based on the concept provisions of the sustainable development. This system is aimed at achieving the positive dynamics of indicators characterizing the industrial enterprises influence on the environment as well as a level of the ecological purity offered to the market products. The conducted researches allowed allocating the EMSE components, namely, subjects and objects of the system, the purposes and methods of their implementation. Figure 1 shows the relationships between these components. In using the EMSE development, the system objectives are constantly updated taking into account the changing of the internal and external environment conditions of the industrial enterprise. That is, they, as EMSE in the whole, are cyclical. The EMSE full cycle covers the stages of forming and implementing its goals.

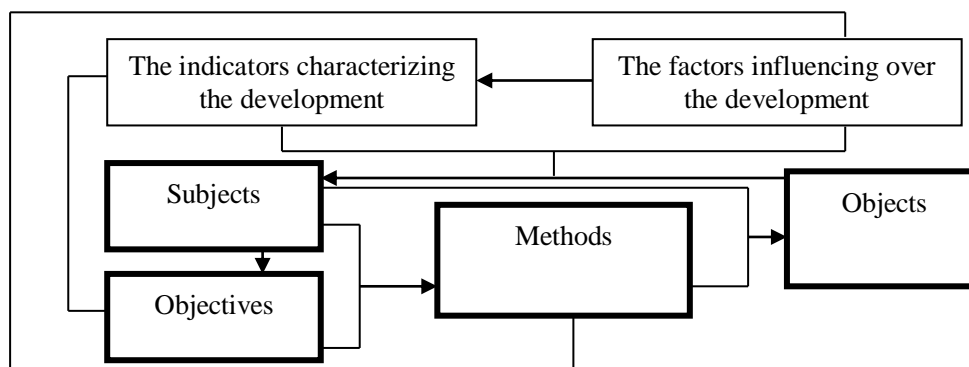

Figure 1. The EMSE development system

After achieving the set goals, the new ones are set, that is, the cycle begins again. The cyclicity of meeting the public needs for a clean environment, as well as environmentally friendly products can be represented as follows:

$$\begin{aligned} \dots \rightarrow r_1^- \rightarrow M \rightarrow N \supset \begin{bmatrix} r_1^- \\ m_1 \end{bmatrix} \rightarrow i_1 \rightarrow K \rightarrow r_1^+ \rightarrow M \rightarrow N \rightarrow r_2^- \rightarrow \\ \rightarrow M \rightarrow N \supset \begin{bmatrix} r_2^- \\ m_2 \end{bmatrix} \rightarrow i_2 \rightarrow K \rightarrow r_2^+ \rightarrow M \rightarrow N \rightarrow r_3^- \rightarrow \dots, \end{aligned} \quad (1)$$

where r_1^+ , r_2^+ – are the society met environmental needs, including the consumers of environmentally friendly products at the first and second cycle stages; r_1^- , r_2^- – are the society unmet environmental needs, including consumers of environmentally friendly products at the first and second cycle stages; M – the methods of identifying the society environmental needs, including the consumers of environmentally friendly products at the first and second cycle stages; m_1 , m_2 – the elements of the research methods of the society environmental needs, including the consumers of environmentally friendly products at the first and second cycle stages; N – the market segment investigated by an industrial enterprise; i_1, i_2 – the information obtained as a result of studying the society unmet environmental needs, including the consumers of environmentally friendly products at the first and second cycle stages; K – the development and implementation of the solutions aimed at meeting the society identified environmental needs, including the consumers of environmentally friendly products at the first and second cycle stages.

Researching the society local environmental needs in the region the enterprise is located, as well as showing the market segment, on which the industrial enterprise is oriented, reveal a certain dissatisfied need r_1^- . The upper negative index indicates that the EMSE is open in this case. Given this, in the marketing research of the society environmental needs, including the consumers of environmentally friendly products, the thorough processing of information received and developing the ways of meeting the identified needs. When the enterprise is already ready to meet the need r_1^- and implements the certain management and engineering solutions to transform r_1^- into r_1^+ , the EMSE is closed informatively relative to the external environment. The information closure is temporary and fragmentary. On the one hand, the enterprise in order to protect intellectual property rights and avoid premature leakage of confidential information implements the measures aimed at strengthening the information security, and, on the other hand, begins an advertising campaign aimed at informing the society and potential consumers on: the planned environmental measures; the newly created, or modified improved environmentally friendly goods; the relevance of meeting the identified needs; cooperates with business

partners to perform certain engineering and technological operations on outsourcing terms.

An industrial enterprise that offers a certain product to the market for a long time, as a rule, knows its market segment well, so the identifying of the consumers' unmet needs of a traditional product is quite problematic. In most cases, manufacturers through establishing the mechanism of the customer warranty and service receive information on the sold products shortcomings and work to eliminate them. The studies have shown that increasing the level of the products environmental cleanliness known on the market does not provide a rapid increase in its sales volumes, but in the long term forms a stable positive image for the manufacturer and eventually turns into its competitive advantage.

Thus, if the enterprise based on the marketing study was able to obtain the information on the unmet environmental need by society and consumers, then it is a consequence of creating a new market research method and a new cycle prerequisite, a cycle in the development by the EMSE enterprise. This happens in the cases of replacing the traditional materials with the new environmentally friendly ones or in the case of applying the new production technologies that are safer for the environment and consumers. That is, applied in a certain combination, the research methods and the obtained information generate a new production factor. In the conditions of permanent strengthening the society informatization level, the information is one of the most important production factors. This factor peculiarity is that its importance depends on the participation of business entities in the analysis of the environment they are located in, as well as in the activity of the subjects' information impact on the environment. As a result of transforming the input information into the output one by an industrial enterprise, the changes occur in their internal and external environments. This process is subject to the principle of maximum mutual information [17]. Its essence can be formulated as follows -the changes in the enterprises' markets depend on quantitative and qualitative parameters, as well as input and output data flows in the EMSE. In formalized form this principle is written as follows:

$$I(R_a, R_b) = \max_{R_a, R_b}, \quad (2)$$

where, R_a – the input data flows in EMSE; R_b – the output data flows in EMSE.

Returning to the above mentioned cycle of meeting the society environmental needs and consumers' needs in the environmentally friendly goods on the markets by enterprises (1), it is possible to demonstrate in what way the conditions, causes and consequences of the EMSE development interact on the basis of the principle of maximum information interaction. Thus, r_1^-, r_2^- and i_1, i_2 are the conditions for the EMSE development that are equivalent to R_a , that is, $r_1^-, r_2^- \wedge i_1, i_2 \square R_a$. In its turn, $K \wedge r_1^+, r_2^+$ correlate with each other as a cause and sequence of the impact of the outgoing data flows on the EMSE development, that is $K \square R_b \rightarrow r_1^+, r_2^+$.

The concept of “maximum mutual information” is quite conditional, since

the information volume and quality are limited by the resources that represent the technology of obtaining information, as well as by the uncertainty of changing the consumer needs nature [17]. Given these maximization circumstances of the information on which the EMSE development depends, the Langrangian method can be written

$$L(R_a, R_b) = I(R_a, R_b) - \sum_{i=1}^n \lambda_i Z_i(R_a, R_b) = \max_{R_a, R_b}; Z_i(R_a, R_b) \leq \text{const}(i = 1, 2, \dots, n);$$

$$L(R_a, R_b) = H(R_a) - H\left(\frac{R_a}{R_b}\right) - \sum_{i=1}^n \lambda_i Z_i \vee L(R_a, R_b) = H(R_b) - H\left(\frac{R_b}{R_a}\right) - \sum_{i=1}^n \lambda_i Z_i, \quad (3)$$

where L – the construction function through a certain variation principle of the motion equation describing the EMSE development; λ_i – the indefinite Lagrangian multiplier; Z_i – the limitation of information by resources; $H(R_a), H(R_b)$ – the unconditional entropy of the society environmental needs and consumers' needs in environmentally friendly goods; $H(R_a / R_b), H(R_b / R_a)$ – the conditional entropy of the society environmental needs and consumers' needs in environmentally friendly goods.

Entropy, as a measure of the environment uncertainty in which the EMSE is located, is directly related to the concept of “evolution interval” (cycle duration). This concept is a set of time periods that cover the time of the EMSE formation, the time of its stationary state (the state of using the system by users), as well as of destructing the system.

The EMSE formation time includes the discharge interval from the working tool consumption environment, the assimilation interval of the means of identifying demand and ways of its satisfaction, and the interval of the solutions formation and implementation to meet the society identified environmental needs and the consumers' needs in environmentally friendly products. Regarding the elimination interval of the EMSE restrictions, it provides for dissimulating the established research method of the changes nature in the society environmental needs and the consumers' needs for environmentally friendly products in a particular market segment. Including the new methods of identifying social needs and consumer demand in the system and excluding the old methods lead to a change in the entropy system, which is inherently an organizationally open state of the system. As a consequence, in the EMSE evolution process there is a periodic opening and closing the system, the transition from unstable to stable state and Vice versa [17].

4.2. The alternative options of modeling the EMSE development and allocating the formation stages of the enterprise ecological potential as a set of opportunities which are a basis for the EMSE development

Within the EMSE a large number of processes are implemented, which is essentially a set of technologies of implementing the management and engineering functions of environmental planning, its organization, motivating the management subjects to timely and full implementating the set goals, as well as their control

and regulation. The constituent elements of any technological process in the EMSE are the management and engineering operations, the implementation of which in a certain sequence is the technology of implementing the specific management functions, which are interconnected by linear and functional relationships. Constructing the systems that would fully reflect these relationships is almost impossible because of the number of relationships, as well as their instability due to tactical, in particular, the operational intervention of industrial managers in implementing the management and engineering processes. In modern conditions, the competition achievement only through the price policy is impossible, it is also necessary to adapt timely to changes in the external environment. This rapid response can be achieved by: identifying the key processes that occur inside the EMSE; describing the processes with a unified language; identifying the bottle-necks in the management and engineering processes; optimizing the processes of improving their manageability, avoiding the unnecessary operations. In fact, in the EMSE the optimization process of the management and engineering processes is constant and endless. The introduction of the new scientific, technical and methodological developments, the creative approaches in management allows us to constantly improve the EMSE development level.

ISO 9000: 2000 defines the process – it is the activities that interact and depend on each other, transform input into output and are valuable to consumers. Within this definition, “process” can be understood as a direct activity for the implementation of which certain types of resources (human, financial, material, information, etc.) are used to convert the input elements into the output ones. A process includes one or more related procedures or functions that jointly implement a task. One of the most important steps to improve the manageability of transformations in the EMSE is the identification of the management and engineering processes. To solve the problem of managing the EMSE formation, modeling of this process was used. Modeling allows you: to get a simple and clear description of the business processes on the model “as is”; to determine the current problems that exist in the business processes; to identify the ways to overcome existing problems and build a model “to be”; to offer the priority directions of the transition from the model “as is” to the model “to be” based on the analysis of the built model's advantages and disadvantages.

The EMSE model is formed with using AllFusion Process Modeler (BPWin) – a software product that is one of the generally accepted standards of structural description of processes. This program implements SADT (Structured Analysis & Design Technique), which allowed building a simplified model of complex business processes in the framework of the EMSE system. The key element of any SADT model is the SA block shown in Fig. 2. SA-block is designed to reflect the action, function or process in which the input by a mechanism (a performer) turns into the output under the controlled influence of management and engineering solutions that accompany the EMSE development.

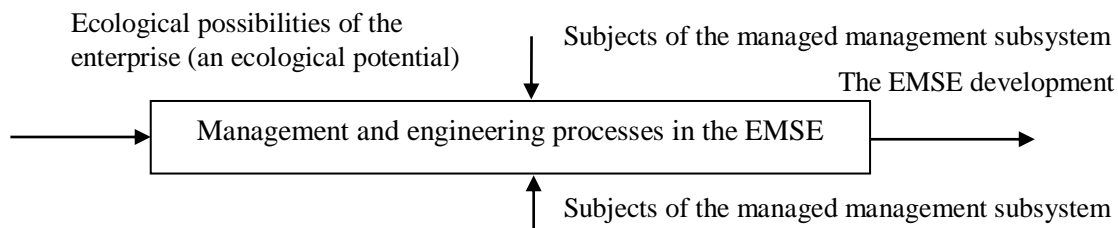

Figure 2. SA-block of the EMSE model

The EMSE model built according to the scheme “as is” is shown in Fig. 3. The given model abstractly describes the inputs, outputs and the mechanism of managing the processes in the EMSE. Briefly, this model can be described as follows: the usage of the enterprises' opportunities is a process in which, under the influence of the society environmental needs and market conditions, pursuing their local goals, enterprises carry out economic activities, as a result a certain structure of the EMSE is formed. The studies have shown that the process of the EMSE development is a set of the stages identifying and meeting the society environmental needs and consumers' needs for environmentally friendly products, which can be implemented both during the production and sale of these products (that is, coincide with it in time), and during the market research and interaction with the existing and potential consumers, holding the negotiations with potential buyers, etc.

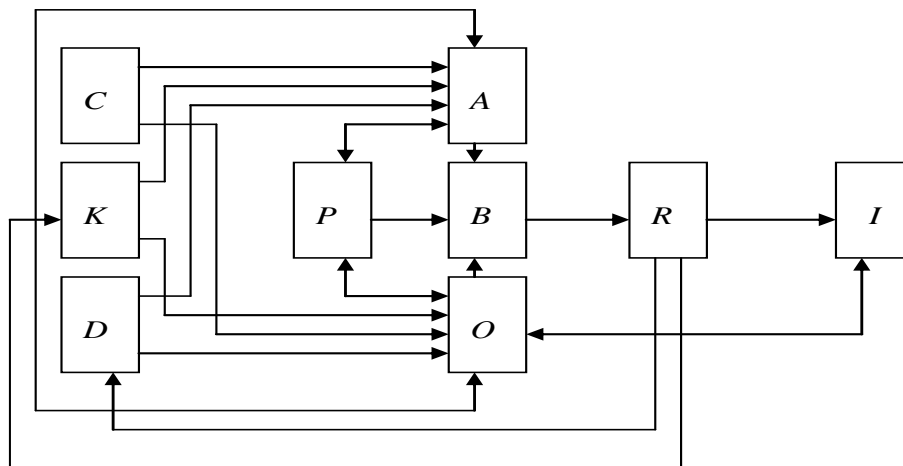

Figure 3. Model of the EMSE development according to the scheme “as is”.

The conventional signs: *A* – the management subsystem subjects of the EMSE development; *B* – the business processes in the EMSE development system; *C* – the system objectives; *D* – the state controlling the environmental measures development and the environmental protection activities; *I* – the local social formations in the region the plant is located, including the consumers of the enterprise production; *K* – the market conditions; *R* – the flow providing the enterprise through the usage of the environmental opportunities; *O* – the subjects of the controlled management subsystem; *P* – the ecological opportunities of the enterprise.

After identifying the demand nature, the next stage is to find the best model of meeting it. The environmentally friendly goods become one of the elements of the EMSE when the enterprise has already overcome the engineering and technological barriers and achieved the quality and price competitive advantages on the market. The main drawback of the EMSE development process on the model “as is” is the lack of causal links between the implemented management and engineering processes and the actions of the other subjects of business relations, which is associated with the decentralization of the EMSE usage. Given this drawback, a model of using the ecological potential according to the scheme “to be” is constructed (Fig. 4). The key difference between the schemes of the models “as is” and “to be” is a set of the factors that are taken into consideration by industrial enterprises, in particular, it is about consistency of choice of ways of implementing the set managerial and engineering-technological goals on the basis of the results of the EMSE development.

The concepts of the EMSE development implemented in many economically developed countries have been successful through the practical implementing the so-called “partnership model”, which involves a certain democratization of environmental policy formation by legitimizing certain forms of lobbying the industrial enterprises' interests at different government levels. The studies have shown that the most common of them is the industry clustering.

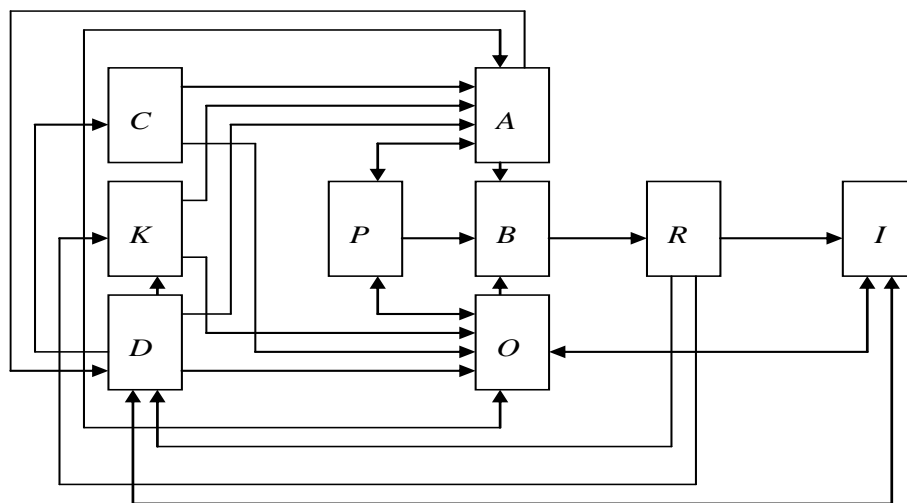

Figure 4. Model of the EMSE development according to the scheme “to be”.

In France, the UK, Canada the industry clusters relying on the current system of the government preferences, lobby for signing individual bills, approving the state programs and government decisions that affect the market situation. It inevitably affects the EMSE objectives nature and leads to partnerships between enterprises and public administration in the optimizing direction of meeting the society environmental needs and consumers' needs for environmentally friendly products.

Partnership involves the coordination of short-, medium-, and long-term interests of partner enterprises, taking into account the state's interests. Based on

the analysis of the world experience among the vectors of the EMSE development are: increasing the share of producing environmentally friendly products; diversifying the nomenclature and assortment of environmentally friendly products offered to the market; the usage of new technologies as a factor in reducing environmental pollution both during production and its processing and disposal.

Thus, the EMSE development covers two stages (Fig. 5). At the first stage, combining the disparate environmental opportunities of the enterprise (A_x, B_y, C_z, D_n, I_m) takes place in the EMSE ($\cup P_e$), and at the second one, joining the new environmental opportunities by the production enterprise (x, y, z, n, m), consisting of the sets' combination $\cup P_e'$ with the existing EMSE. $\cup P_e'$ arises owing to the development of $\cup P_e$. As a result of joining the components $\cup P_e'$ to $\cup P_e$ a new set of its components is formed – $\cup P_e''$. The formation process of the EMSE shown in Fig. 5 is solved from the progressive development position, because after the occurrence $\cup P_e$ the process of joining the new components to the existing EMSE is considered, but it is obvious that through the irrationality of the enterprise management subjects' decisions or due to the appearance of force majeure or other objective circumstances the operating $\cup P_e$ can provide for a regressive development. In this case, from the point of view of set theory, the changes in the potential of the EMSE will have the allocation pattern, i. e. the phenomenon of reducing environmental opportunities will take place in the enterprise. It is obvious that such a destructive experience should be investigated for the factors that predetermine the regressive development, as well as developing the methods for their consideration by the management subjects.

In Fig. 5 the selection stage of the components from a set $\cup P_e$ is unpredictable, as the strategic and tactical management of ecological potential even in the conditions of pessimistic development of events is focused on progressive development.

It is necessary to recognize that the level of rational using the company's environmental potential will be high provided that the company's managers permanently have complete and reliable information about the factors' list and nature that affect the company's environmental potential. Taking this into account, the further research should be carried out in the direction of forming the algorithmic environmental monitoring systems that would perform the functions of processing and classifying the studied factors based on the cluster analysis, and also allow building dendrites to identify the relationships between the factors. Note, that in this case, it is about the technical environmental monitoring systems that focus exclusively on the technical indicators.

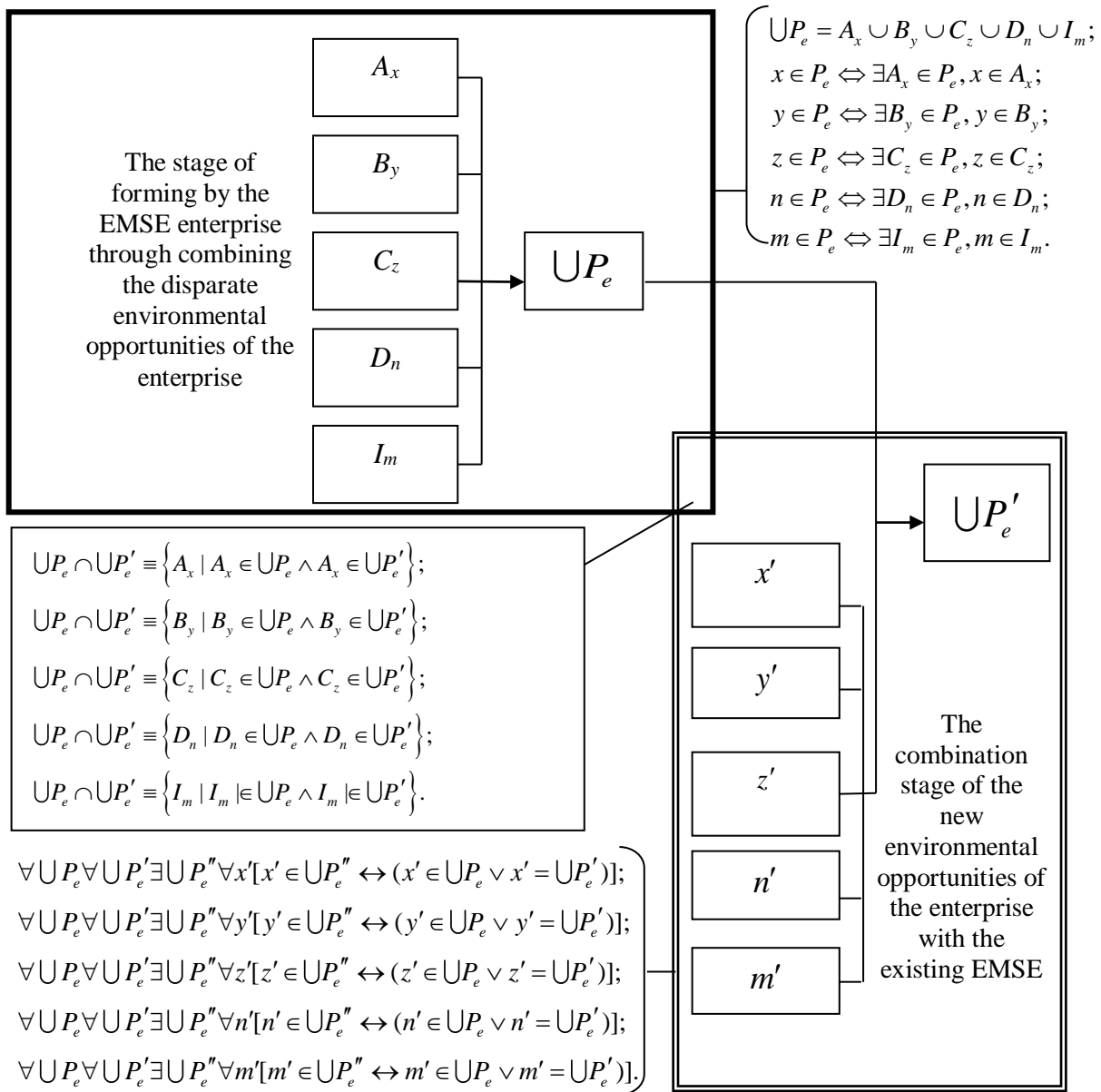

Figure 5. The formation stages of the enterprise ecological potential.

The conventional signs: one stroke indicates the new elements attached to the existing EMSE; two strokes indicate the set of the elements attached to the existing EMSE.

These systems are surely to include the factors that reflect changes in demand and supply for eco-products, as well as trends in forming the public opinion about certain phenomena that relate to the environmental safety. The availability of such environmental monitoring systems will contribute to the validity of management decisions that are aimed at ensuring the expected parameters of the enterprise's environmental management system development.

5. Conclusions

- among the EMSE structural elements, the engine of its functioning is the management subjects. It is the management subjects who establish the whole systems and choose the methods to achieve them. Given that, the values of the management subjects determine the meeting level of the society environmental needs, including the meeting of the consumers' needs in environmentally friendly goods;
- since industrial enterprises are a component of the sustainable development system, then the EMSE built by them are permanently exposed to the external environment. In its turn, the response level of an industrial enterprise to the external challenges largely depends on its environmental potential;
- the enterprise's ecological potential is the enterprise opportunities set for meeting the society ecological needs and also meeting the consumers' needs in environmentally friendly goods on the basis of the EMSE development based on the concept provisions of the sustainable development;
- the EMSE development sign is an increase in the enterprise environmental potential.

References

1. Wiesner, R., Chadee, D., & Best, P. (2017). Managing Change Toward Environmental Sustainability: A Conceptual Model in Small and Medium Enterprises. *Organization & Environment*, 31(2), 152–177. doi: <https://doi.org/10.1177/1086026616689292>.
2. Lesníková, P., & Schmidtová, J. (2019). Environmental Management in the Context of Corporate Sustainability Concept. *System Safety: Human - Technical Facility - Environment*, 1(1), 352–362. doi: <https://doi.org/10.2478/czoto-2019-0045>.
3. Todaro, N. M., Daddi, T., Testa, F., & Iraldo, F. (2019). Organization and management theories in environmental management systems research: A systematic literature review. *BUSINESS STRATEGY & DEVELOPMENT*, 3(1), 39–54. doi: <https://doi.org/10.1002/bsd2.77>.
4. Tan-Mullins, M., & Mohan, G. (2012). The potential of corporate environmental responsibility of Chinese state-owned enterprises in Africa. *Environment, Development and Sustainability*, 15(2), 265–284. doi: <https://doi.org/10.1007/s10668-012-9409-x>.
5. Yasnolob, I. et al. (2019). The Formation of the Efficient System of Ecological Enterprise. *Journal of Environmental Management and Tourism*, 9(5), 1052–1061. doi: [https://doi.org/10.14505/jemt.9.5\(29\).17](https://doi.org/10.14505/jemt.9.5(29).17).
6. Zhang, H., & Jiang, N. (2019). Discussion on Environmental Protection and Enterprise Economic Development. *IOP Conference Series: Earth and Environmental Science*, 242, 052004. doi: <https://doi.org/10.1088/1755-1315/242/5/052004>.
7. Kosyakova, I. V. (2019). *The Impact Of Environmental Risks On The Management Of Industrial Enterprises*. doi: <https://doi.org/10.15405/epsbs.2019.03.163>.
8. Cherchyk, L. (2019). Environmental security in the system management of the enterprise. *Economic Journal of Lesia Ukrainka Eastern European National University*, 1(17), 55–61. doi: <https://doi.org/10.29038/2411-4014-2019-01-55-61>.
9. Fang, K., Wei, Q., & Logan, K. K. (2017). Protecting the Public's Environmental Right-to-Know: Developments and Challenges in China's Legislative System for EEID, 2007-2015. *Journal of Environmental Law*, 29(2), 285–315. doi: <https://doi.org/10.1093/jel/eqx014>.

10. Kniaz, S., Pavlenko, E., Rubel, O., & Zavnerchik, O. (2018). FUNDING MECHANISMS FOR IMPLEMENTATION OF MARINE STRATEGY FRAMEWORK DIRECTIVE: EU EXPERIENCE. *Financial and Credit Activity: Problems of Theory and Practice*, 4(27), 341–348. doi: <https://doi.org/10.18371/fcaptp.v4i27.154215>.
11. Laroche, M., Bergeron, J., & Barbaro-Forleo, G. (2001). Targeting consumers who are willing to pay more for environmentally friendly products. *Journal of Consumer Marketing*, 18(6), 503–520. doi: <https://doi.org/10.1108/eum0000000006155>.
12. Martin, J.-L., Maris, V., & Simberloff, D. S. (2016). The need to respect nature and its limits challenges society and conservation science. *Proceedings of the National Academy of Sciences*, 113(22), 6105–6112. doi: <https://doi.org/10.1073/pnas.1525003113>.
13. Cao, X., Deng, M., Song, F., Zhong, S., & Zhu, J. (2019). Direct and moderating effects of environmental regulation intensity on enterprise technological innovation: The case of China. *PLOS ONE*, 14(10), e0223175. doi: <https://doi.org/10.1371/journal.pone.0223175>.
14. Malik, C., & Singhal, N. (2017). Consumer Environmental Attitude and Willingness to Purchase Environmentally Friendly Products: An SEM Approach. *Vision: The Journal of Business Perspective*, 21(2), 152–161. doi: <https://doi.org/10.1177/0972262917700991>.
15. Pacana, A. (2019). Analysis of the Design and Implementation Phase of ISO 14001 Environmental Management Systems in Manufacturing Enterprises. *System Safety: Human - Technical Facility - Environment*, 1(1), 391–397. doi: <https://doi.org/10.2478/czoto-2019-0050>.
16. Tezer, A., & Bodur, H. O. (2019). The Greenconsumption Effect: How Using Green Products Improves Consumption Experience. *Journal of Consumer Research*. doi: <https://doi.org/10.1093/jcr/ucz045>.
17. Havrylov, E. V, Dmytrychenko, M. F., & Dolya V. K. ta in. (2005). *Osnovy teorii i upravlinnya* (Kyiv: Znannya Ukrainy).
18. Babych, M., Korobka, S., Skrynkovskyy, R., Korobka, S., & Krygul, R. (2016). Substantiation of economic efficiency of using a solar dryer under conditions of personal peasant farms. *Eastern-European Journal of Enterprise Technologies*, 6(8(84)), 41–47. doi: <http://dx.doi.org/10.15587/1729-4061.2016.83756>.
19. Lozovan, V., Dzhala, R., Skrynkovskyy, R., & Yuzevych, V. (2019). Detection of specific features in the functioning of a system for the anti-corrosion protection of underground pipelines at oil and gas enterprises using neural networks. *Eastern-European Journal of Enterprise Technologies*, 1(5(97)), 20–27. doi: <http://dx.doi.org/10.15587/1729-4061.2019.154999>.
20. Lozovan, V., Skrynkovskyy, R., Yuzevych, V., Yasynskiy, M., & Pawlowski, G. (2019). Forming the toolset for development of a system to control quality of operation of underground pipelines by oil and gas enterprises with the use of neural networks. *Eastern-European Journal of Enterprise Technologies*, 2(5(98)), 41–48. doi: <http://dx.doi.org/10.15587/1729-4061.2019.161484>.
21. Yuzevych, L., Skrynkovskyy, R., Yuzevych, V., Lozovan, V., Pawlowski, G., Yasynskiy, M., & Ogirko, I. (2019). Improving the diagnostics of underground pipelines at oil-and-gas enterprises based on determining hydrogen exponent (PH) of the soil media applying neural networks. *Eastern-European Journal of Enterprise Technologies*, 4(5(100)), 56–64. doi: <http://dx.doi.org/10.15587/1729-4061.2019.174488>.
22. Yuzevych, L., Yankovska, L., Sopilnyk, L., Yuzevych, V., Skrynkovskyy, R., Koman, B., Yasinska-Damri, L., Heorhiadi, N., Dzhala, R., & Yasynskiy, M. (2019).

Improvement of the toolset for diagnosing underground pipelines of oil and gas enterprises considering changes in internal working pressure. *Eastern-European Journal of Enterprise Technologies*, 6(5(102)), 23–29. doi: <http://dx.doi.org/10.15587/1729-4061.2019.184247>.

23. Kniaz, S., & Heorhiadi, N. (2016). Structure, possibilities and prospects of the development of virtual economy and creative industries. *Actual Problems of Economics*, 183(9), 346–351.

24. Popova, N., Kataiev, A., Skrynkovskyy, R., & Nevertii, A. (2019). Development of trust marketing in the digital society. *Economic Annals-XXI*, 176(3-4), 13–25. doi: <https://doi.org/10.21003/ea.V176-02>.

25. Kniaz, S., & Luchko, H. (2015). Current state and problems in derivatives market functioning in Ukraine. *Actual Problems of Economics*, 168(6), 347–354.

26. Kniaz, S., & Kosovska, V. (2015). Grounding the need for transfer system development between industrial enterprises. *Actual Problems of Economics*, 170(8), 16–23.

27. Skrynkovskyy, R. (2008). Investment attractiveness evaluation technique for machine-building enterprises. *Actual Problems of Economics*, 7(85), 228–240. URL: <http://www.scopus.com/inward/record.url?eid=2-s2.0-77952681437&partnerID=MN8TOARS>.

28. Skrynkovskyy, R. M. (2011). Methodical approaches to economic estimation of investment attractiveness of machine-building enterprises for portfolio investors. *Actual Problems of Economics*, 118(4), 177–186. URL: <http://www.scopus.com/inward/record.url?eid=2-s2.0-84930489016&partnerID=MN8TOARS>.

29. Yuzevych, V., Skrynkovskyy, R., & Koman, B. (2018). Intelligent Analysis of Data Systems for Defects in Underground Gas Pipeline. *2018 IEEE Second International Conference on Data Stream Mining & Processing (DSMP)*. doi: <https://doi.org/10.1109/dsmp.2018.8478560>.

30. Yuzevych, L., Skrynkovskyy, R., & Koman, B. (2017). Development of information support of quality management of underground pipelines. *EUREKA: Physics and Engineering*, 4, 49–60. doi: <https://doi.org/10.21303/2461-4262.2017.00392>.

31. Kniaz, S. (2015). Transfer potential for innovative development of industrial and trade organizations. *Actual Problems of Economics*, 169(7), 57–64.

32. Heorhiadi, N., Bets, M., & Fedorchak, O. (2016). Optimal investment portfolio formation at Ukrainian stock market. *Actual Problems of Economics*, 182(8), 361–371.

33. Yuzevych, V., Klyuvak, O., & Skrynkovskyy, R. (2016). Diagnostics of the system of interaction between the government and business in terms of public e-procurement. *Economic Annals-XXI*, 160(7-8), 39–44. doi: <https://doi.org/10.21003/ea.v160-08>.

34. Heorhiadi, N., Druhov, O., Vilhutska, R., Bets, M., & Stoianovskyy, A. (2018). Organizational development in banks management systems. *Banks and Bank Systems*, 13(3), 1–11. doi: [https://doi.org/10.21511/bbs.13\(3\).2018.01](https://doi.org/10.21511/bbs.13(3).2018.01).

35. Kniaz, S. (2015). The essence of eco-economic, tourism eco-information systems and the interrelation between them. *Actual Problems of Economics*, 171(9), 280–285.