

# Thin-Layer Drying Characteristics and Modelling of Instant Coffee Solution

Apolinar Picado, Ronald Solís, Rafael Gamero

**Abstract**—The thin-layer drying characteristics of instant coffee solution were investigated in a laboratory tunnel dryer. Drying experiments were carried out at three temperatures (80, 100 and 120 °C) and at an air velocity of 1.2 m/s. Drying experimental data obtained are fitted to six (6) thin-layer drying models using the non-linear least squares regression analysis. The acceptability of the thin-layer drying model has been based on a value of the correlation coefficient that should be close to one, and low values for root mean square error (*RMSE*) and chi-square ( $\chi^2$ ). According to this evaluation, the most suitable model for describing drying process of thin-layer instant coffee solution is the Page model. Further, the effective moisture diffusivity and the activation energy were computed employing the drying experimental data. The effective moisture diffusivity values varied from  $1.6133 \times 10^{-9}$  to  $1.6224 \times 10^{-9}$  m<sup>2</sup>/s over the temperature range studied and the activation energy was estimated to be 162.62 J/mol.

**Keywords**—Activation energy, Diffusivity, Instant coffee, Thin-layer models.

## I. INTRODUCTION

INSTANT or soluble coffee is an invention of the early twentieth century and nowadays it plays an important role besides other preparation techniques due to easy handling and longer durability [1]. Instant coffee is produced from roasted and ground coffee beans. The ground beans are extracted with hot water to recover the coffee flavour and aroma [2]. The coffee extract is then dried to produce instant coffee powder; after which it can be rehydrated.

Drying process is a major step in food processing. This step is crucial since it will dictate the final quality of the heat-sensitive foods. The most common drying methods for instant coffee production are spray drying and freeze-drying. Freeze-drying leads to the best product quality in terms of aroma recovery but requires a huge amount of investment and operating costs. Spray drying stands out due to high production capacities at low energy costs but it results in a higher thermal impact on the product, which may lead to lower product qualities.

A. Picado is with the Dept. of Technology and Pre-Engineering, Keiser University - Latin American Campus, San Marcos 45000, Nicaragua (e-mail: apolinar.picado@keiseruniversity.edu).

R. Solís was with the Faculty of Chemical Engineering, National University of Engineering (UNI), Managua 11127, Nicaragua (e-mail: rsolism@yahoo.com).

R. Gamero is with the Faculty of Chemical Engineering, National University of Engineering (UNI), Managua 11127, Nicaragua (e-mail: rafael.gamero@fiq.uni.edu.ni).

Studies focusing on the coffee behaviour during the drying process have been reported by several researchers. For instance, Corrêa *et al.* [3] studied the drying characteristics and kinetics of coffee berry under the drying temperatures of 40, 50 and 60 °C. Further, Corrêa *et al.* [4] observed the moisture sorption isotherms and isosteric heat of sorption of coffee in different processing levels. Ciro-Velásquez *et al.* [5] performed a numerical simulation of thin-layer coffee drying by control volumes employing air temperatures of 40, 50 and 60 °C. Burmester *et al.* [1] investigated the instant coffee production by vacuum belt drying and it was found that by optimised process parameters instant coffee can be produced. Muhindong and Rahman [6] evaluated the behaviour of Arabica coffee (*Coffea arabica* L.) bean during the single-layer drying process under several levels of drying air velocity. To our knowledge, there is no information in the literature about thin-layer models for the convective drying of instant coffee.

The purpose of this study was to investigate the drying characteristics of instant coffee solution, as well as the suitability of several empirical and semi-empirical models available in the literature in defining the thin-layer drying characteristics of instant coffee solution. The effective moisture diffusivity at various temperatures and activation energy were estimated.

## II. MATERIALS AND METHODS

### A. Material

Instant coffee used in the experiments was a commercial instant coffee manufactured by Café Soluble, S.A., Nicaragua. The instant coffee solution was formulated by mixing 3 g of instant coffee powder (having a moisture content of 6.5% on a wet basis) with 7 mL of water at 22 °C. The moisture content of the resulting instant coffee solution was 72% on a wet basis [7].

### B. Experimental Apparatus

A schematic arrangement of the experimental apparatus is shown in Fig. 1. The equipment may be divided into four main sections as follows: gas supply and dehumidification section, heating section, drying chamber, and analysing equipment. The blower (B) supplies a gas flow—a broad range of flow rates are possible by changing the rpm setting through the frequency inverter (FI). The air passes through an adsorption column (AC) containing a dehumidificant (i.e. silica gel) to obtain a process air of low humidity content (less than 1.0 % relative humidity) measured by a hygrometer. The air velocity

is measured by an anemometer. After dehumidification, the air is pre-heated with electrical resistance (ER) heaters of up to 2 kW each. Temperature is controlled by means of a temperature controller (TC) that supplies heat by means of an electrical resistance heater as its final control element. Before entering the drying chamber a static mixer homogenises temperature by mixing the gas. The sample is put in a sample holder (SH) inside the drying chamber and is supported on a

weighing balance (WB) through an oil-sealed shaft. The cross-sectional area and depth of sample holder are 30.65 mm × 109.8 mm and 3 mm, respectively. The drying chamber has a uniform cross-sectional area of 90 mm × 110 mm. The sample's weight history is recorded on a computer (C). It is possible to take a reading every 12 seconds [8].

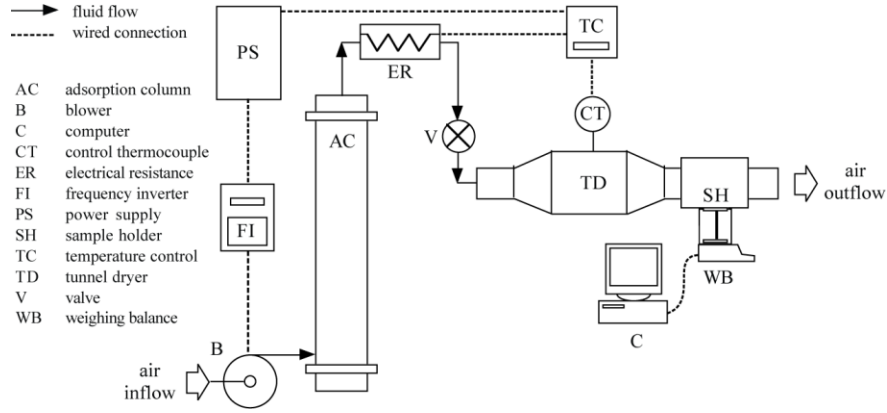

Fig. 1 A schematic diagram of a tunnel drying system.

### C. Experimental Procedure

The experiments were performed at an air velocity of 1.2 m/s and at three temperatures: 80, 100 and 120 °C. Before starting an experiment, the apparatus was run for at least half an hour to obtain steady-state conditions. The sample was loaded evenly in the sample holder, which covered the whole drying area as a thin-layer. The sample holder was put into the tunnel dryer. The drying time and mass of the sample were recorded. The test was stopped until the mass was invariable. After drying by the apparatus above, the sample was further dried in an oven at 105 °C for 24 hours to determine its oven-dry mass ( $m_d$ ). The initial mass, drying mass and oven-dry mass were determined with a precise analytical balance. All the drying experiments were performed in triplicate. Post-processing of these data yields the drying kinetics [8].

### D. Mathematical Modelling of Drying Curves

The moisture content of drying sample at time  $t$  can be transformed to be moisture ratio ( $MR$ ):

$$X_t = \frac{m_t - m_d}{m_d} \quad (1)$$

$$MR = \frac{X_t - X_{eq}}{X_0 - X_{eq}} \quad (2)$$

where  $X_t$ ,  $m_t$  and  $m_d$  are moisture content at any time (kg water/kg dry matter), mass of sample at any time (kg) and

absolute dried mass of sample (kg), respectively.  $MR$ ,  $X_0$  and  $X_{eq}$  are moisture ratio (dimensionless), initial moisture content (kg water/kg dry matter) and equilibrium moisture content (kg water/kg dry matter), respectively.

The drying rate ( $N_v$ ) of instant coffee solution is calculated employing the following equation:

$$N_v = \frac{1}{A_s} \left( \frac{X_{t+dt} - X_t}{dt} \right) \quad (3)$$

where  $N_v$  is drying rate (kg water/m<sup>2</sup>·s),  $X_{t+dt}$  is moisture content at  $t+dt$  (kg water/kg dry matter),  $t$  is the drying time (s),  $dt$  is time increment (s) and  $A_s$  is drying area (m<sup>2</sup>).

The drying data obtained are fitted to six (6) thin-layer drying models detailed in Table I using the non-linear least squares regression analysis. Regression analysis is performed using MatLab's Curve Fitting Tool. Generally, the coefficient of correlation ( $r$ ) is the primary criterion for selecting the best model to describe the drying curve and the highest  $r$  value is required. In addition to  $r$ , the root mean square error ( $RMSE$ ) and chi-square ( $\chi^2$ ) are used to determine the best fit. The highest  $r$  and the lowest  $\chi^2$  and  $RMSE$  values required to evaluate the goodness of fit. These statistical values can be calculated as follows [8-9]:

$$r = \frac{N \sum_{i=1}^N MR_{pred,i} MR_{exp,i} - \sum_{i=1}^N MR_{pred,i} \sum_{i=1}^N MR_{exp,i}}{\sqrt{\left( N \sum_{i=1}^N MR_{pred,i}^2 - \left( \sum_{i=1}^N MR_{pred,i} \right)^2 \right) \left( N \sum_{i=1}^N MR_{exp,i}^2 - \left( \sum_{i=1}^N MR_{exp,i} \right)^2 \right)}} \quad (4)$$

$$\chi^2 = \left[ \sum_{i=1}^N (MR_{\text{exp},i} - MR_{\text{pred},i})^2 \right] (N - w)^{-1} \quad (5)$$

$$RMSE = \left[ \frac{1}{N} \sum_{i=1}^N (MR_{\text{exp},i} - MR_{\text{pred},i})^2 \right]^{1/2} \quad (6)$$

where  $MR_{\text{exp},i}$  is the  $i$ th experimental moisture ratio,  $MR_{\text{pred},i}$  is the  $i$ th predicted moisture ratio,  $N$  is the number of observations and  $w$  is the number of constants within the thin-layer drying model.

TABLE I  
THIN-LAYER DRYING MODELS [9]

Number	Model	Model equation
1	Lewis	$MR = \exp(-kt)$
2	Page	$MR = \exp(-kt^n)$
3	Modified Page	$MR = \exp(-kt)^n$
4	Henderson & Pabis	$MR = a \exp(-kt)$
5	Logarithmic	$MR = a \exp(-kt) + c$
6	Demir	$MR = a \exp[-(kt)^n] + b$

Model constants can be obtained by performing multiple regression analysis. These drying models are relatively easy to use in multiple regression analysis, because they could be linearised. However, some models must be solved with non-linear regression techniques and it is too hard to find the solutions to such non-linear models if there are many constants [8].

#### E. Determination of Effective Moisture Diffusivity

Fick's second law of diffusion equation was used to fit the experimental drying data for the determination of effective moisture diffusivity coefficients.

$$\frac{\partial X}{\partial t} = D_{\text{eff}} \frac{\partial^2 X}{\partial z^2} \quad (7)$$

The solution of diffusion (7) for slab geometry is solved by Crank [10] and assumed uniform initial moisture distribution, negligible external resistance, constant diffusivity and negligible shrinkage:

$$MR = \frac{8}{\pi^2} \sum_{n=1}^{\infty} \frac{1}{(2n-1)^2} \exp\left(\frac{-(2n-1)^2 \pi^2 D_{\text{eff}} t}{4H^2}\right) \quad (8)$$

where  $D_{\text{eff}}$  is the effective moisture diffusivity ( $\text{m}^2/\text{s}$ ),  $H$  is the half-thickness of samples (m) and  $n$  is a positive integer. Only the first term of (8) can be used for long drying times [9].

$$MR = \frac{8}{\pi^2} \exp\left(-\frac{\pi^2 D_{\text{eff}} t}{4H^2}\right) \quad (9)$$

The slope is determined by plotting  $\ln(MR)$  against time ( $t$ ) according to (9).

$$\text{Slope} = \frac{\pi^2 D_{\text{eff}}}{4H^2} \quad (10)$$

$D_{\text{eff}}$  mainly varies with internal conditions, such as the temperature of the product, the moisture content and the structure. This is harmonious with the assumption of the thin-layer concept.

#### F. Computation of Activation Energy

The dependence of the effective moisture diffusivity on the temperature is generally described by the Arrhenius equation:

$$D_{\text{eff}} = D_0 \exp\left(-\frac{E_a}{R(T + 273.15)}\right) \quad (11)$$

where  $D_0$  is the pre-exponential factor of Arrhenius equation ( $\text{m}^2/\text{s}$ ),  $E_a$  is the activation energy (kJ/mol),  $R$  is the universal gas constant (kJ/mol·K) and  $T$  is the temperature ( $^{\circ}\text{C}$ ).

### III. RESULTS AND DISCUSSION

#### A. Experimental Observations

During the experimental runs, as soon as the instant coffee solution sample is exposed to the drying air a semi-solid layer is observed on the surface of the sample. As the evaporation progresses the layer grows thicker showing solid-like characteristics as the liquid is evaporated, thus resulting in an instant coffee solution crystallised over the entire sample holder. The extent to how much this layer influences the evaporation will partly depend on how fast it thickens, since the liquid must now diffuse through it to reach the side of the layer exposed to the air (gas-layer interface). The formation of this layer becomes an additional resistance to mass transfer during evaporation.

#### B. Drying Characteristics

The variation of moisture ratio with drying time at air temperatures of 80, 100 and 120  $^{\circ}\text{C}$  for instant coffee solution and at an air velocity of 1.2 m/s are shown in Fig. 2. The moisture ratio of the instant coffee solution samples decreased continually with drying time. As expected, an increase in the drying air temperature reduces the time required to reach any given level of moisture ratio since the heat transfer increases. This can be explained by increasing temperature difference between the drying air and the product and the resultant liquid migration.

Drying rate was estimated based on (3) and its changes with moisture ratio are as shown in Fig. 3. An important influence of air drying temperature on drying rate is observed in the curves. As expected, an increase in the drying air temperature increases the drying rate because higher air temperature causes a higher reduction of moisture content – in other words, at high temperatures the transfer of heat and mass is high and liquid loss is excessive. As can

be seen from Fig. 3, three (3) drying rate periods (i.e. warm-up period, constant rate period and falling rate period) were observed in the drying of instant coffee solution for various drying temperatures (80, 100 and 120 °C) and at an air velocity of 1.2 m/s. These results are in good agreement with earlier observations of various products [9].

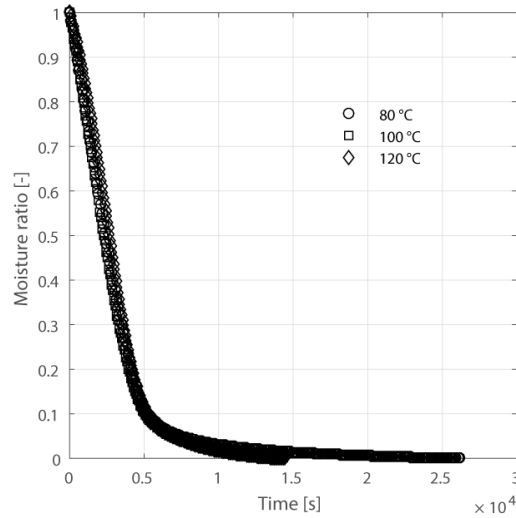

Fig. 2 Drying curves for various temperatures at an air velocity of 1.2 m/s.

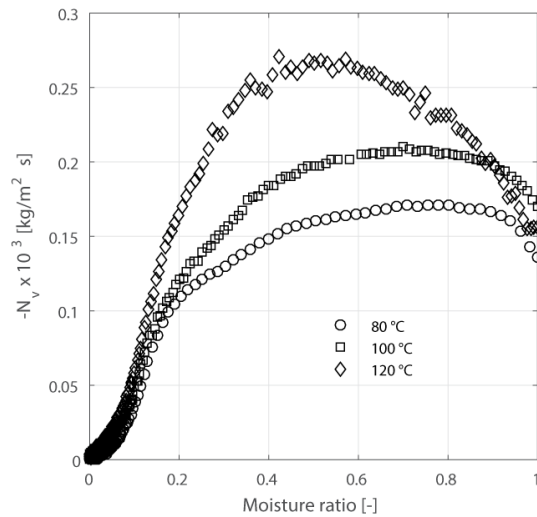

Fig. 3 Drying rate curves for various temperatures at an air velocity of 1.2 m/s.

For the drying experiments, the critical moisture content and the maximum drying rate were determined at the point in which the drying rate started to decrease (i.e. at the beginning of falling rate period). The critical moisture contents were 1.4, 1.3 and 1.1 kg/kg for 80, 100 and 120 °C, respectively. In this study, the equilibrium moisture content was calculated by employing GAB isotherm equation with parameters determined by Alves and Robin [11].

### C. Fitting of Drying Curves

The drying data obtained from the experiments were fitted by six (6) thin-layer drying models reported in Table I. The results of statistical analysis on the thin-layer drying models are given in Tables II-IV. The best model describing the thin-layer drying characteristics of instant coffee solution was chosen as the one with the highest  $r$  and the lowest  $RMSE$  and  $\chi^2$ . The results showed that the Page model exhibited the best fit to drying experimental data.

The Page model exhibits a better suitability with the experimental data not only because of the lower number of coefficients, but also due to the form of the model equation [8]. As known, the Page model is widely used as the basis

for most semi-theoretical thin-layer models [9]. Additionally, the Page model has been adopted as a standard by ASABE in thin-layer modelling of agricultural and biological products [12].

TABLE II  
RESULTS OF STATISTICAL ANALYSIS FOR THE DRYING TEMPERATURE T = 80 °C

Model	Coefficients	<i>r</i>	<i>RMSE</i>	$\chi^2$
Lewis	$k = 0.0003419$	0.9905	0.03144	9.8884 E-4
Page	$k = 1.827 \text{ E-}5, n = 1.36$	0.9980	0.01453	2.1112 E-4
Modified Page	$k = 0.02144, n = 0.01595$	0.9905	0.03151	9.9295 E-4
Henderson-Pabis	$k = 0.0003789, a = 1.116$	0.9944	0.02430	5.9050 E-4
Logarithmic	$k = 0.0003815, a = 1.116,$ $c = 0.002129$	0.9944	0.02429	5.9000 E-4
Demir	$k = 0.00644, a = 1.117,$ $b = 0.003109, n = 0.05952$	0.9944	0.02436	5.9331 E-4

TABLE III  
RESULTS OF STATISTICAL ANALYSIS FOR THE DRYING TEMPERATURE T = 100 °C

Model	Coefficients	<i>r</i>	<i>RMSE</i>	$\chi^2$
Lewis	$k = 0.000364$	0.9889	0.04087	1.6705 E-3
Page	$k = 1.732 \text{ E-}5, n = 1.375$	0.9991	0.01146	1.3144 E-4
Modified Page	$k = 0.00599, n = 0.06064$	0.9888	0.04095	1.6771 E-3
Henderson-Pabis	$k = 4.039 \text{ E-}4, a = 1.124$	0.9941	0.03005	9.0297 E-4
Logarithmic	$k = 3.847 \text{ E-}4, a = 1.129,$ $c = -0.01578$	0.9946	0.02861	8.1829 E-4
Demir	$k = 0.005851, a = 1.129,$ $b = -0.0158, n = 0.06575$	0.9946	0.02867	8.2180 E-4

TABLE IV  
RESULTS OF STATISTICAL ANALYSIS FOR THE DRYING TEMPERATURE T = 120 °C

Model	Coefficients	<i>r</i>	<i>RMSE</i>	$\chi^2$
Lewis	$k = 3.252 \text{ E-}4$	0.9792	0.06020	3.6242 E-3
Page	$k = 2.538 \text{ E-}6, n = 1.594$	0.9988	0.01441	2.0774 E-4
Modified Page	$k = 7.471 \text{ E-}4, n = 0.4356$	0.9792	0.06033	3.6393 E-3
Henderson-Pabis	$k = 3.747 \text{ E-}4, a = 1.172$	0.9886	0.04473	2.0004 E-3
Logarithmic	$k = 3.455 \text{ E-}4, a = 1.182,$ $c = -0.02896$	0.9902	0.04178	1.7446 E-3
Demir	$k = 9.233 \text{ E-}4, a = 1.182,$ $b = -0.02913, n = 0.3739$	0.9902	0.04187	1.7532 E-3

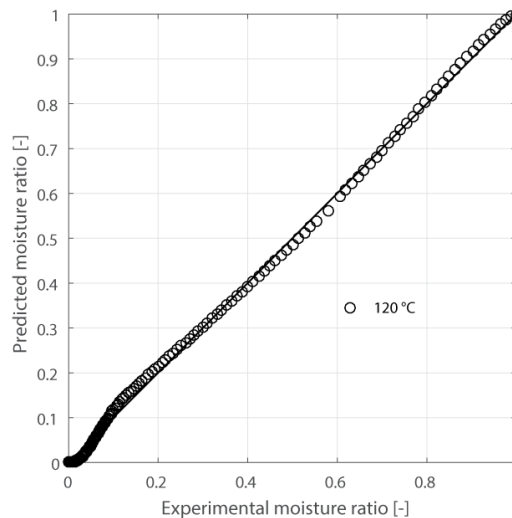

Fig. 4 Comparison of the experimental and predicted moisture ratios at a temperature of 120 °C and at an air velocity of 1.2 m/s.

In this study, the validation of the Page model has also been confirmed by comparing the predicted moisture ratios to the experimental values at a temperature of 120 °C (see Fig. 4). The predicted data is banded around the straight line that showed the suitability of the Page model in describing the drying characteristics of the thin-layer instant coffee solution. Similar results have been reported for other food materials [8].

#### D. Effective Moisture Diffusivity

The values of effective moisture diffusivity were calculated using (11). The  $D_{eff}$  values were varied in the range of  $1.6133 \times 10^{-9}$  to  $1.6224 \times 10^{-9}$  m<sup>2</sup>/s from 80 to 120 °C and at an air velocity of 1.2 m/s. It was observed that  $D_{eff}$  values increased with increasing drying temperature. When samples were dried at higher temperature, increased heating energy would increase the activity of water molecules leading to higher moisture diffusivity [13]. Similar results have been reported for other food materials [9].

#### E. Activation Energy

A plot of  $\ln(D_{eff})$  against  $1/(T + 273.15)$  gave a straight line ( $r^2 = 0.9999$ ), which is shown in Fig. 5. The slope ( $-E_a/R$ ) of the straight line was obtained and by using the Arrhenius relationship, the activation energy was obtained to be 162.62 J/mol. Similar values have been reported for other food materials [9].

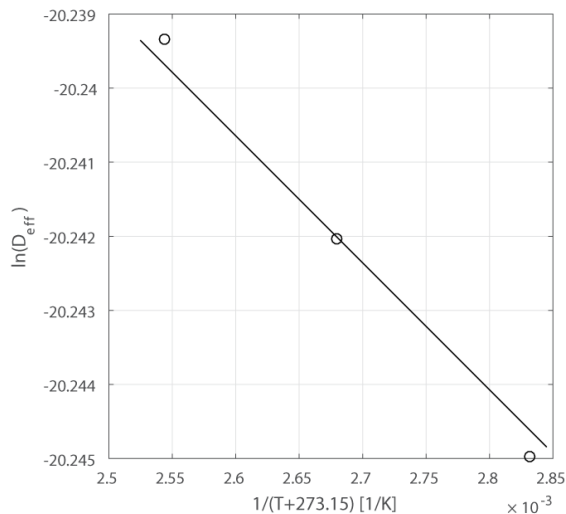

Fig. 5 The relationship of  $\ln(D_{eff})$  and  $1/(T + 273.15)$  at an air velocity of 1.2 m/s.

Semi-theoretical and empirical models, such as Page model, provide adequate representation of experimental results although the parameters of these models have not physical meaning. Semi-theoretical and empirical models do not need assumptions of material properties that from

practical point of view is very important. Therefore, these models give usually good results for engineering application. Semi-theoretical and empirical models, however, frequently did not allow the simulation of experiments carried-out under different conditions to those used to identify the model parameters.

#### IV. CONCLUSIONS

The drying temperatures were found to have a considerable effect on the moisture loss rates of the instant coffee solution. Drying process showed three (3) drying rate periods under all the studied temperatures. The effective moisture diffusivity ranged from  $1.6133 \times 10^{-9}$  to  $1.6224 \times 10^{-9}$  m<sup>2</sup>/s. The activation energy required to move the water out from the instant coffee solution during the drying process was found to be 162.62 J/mol. Under the evaluated experimental conditions, the Page model provided the best representation of thin-layer drying characteristics of instant coffee solution.

#### ACKNOWLEDGMENTS

The authors gratefully acknowledge the financial support provided by the Swedish International Development Cooperation Agency (Sida).

#### REFERENCES

- [1] K. Burmester, A. Pietsch and R. Eggers, "A basic investigation on instant coffee production by vacuum belt drying," *Procedia Food Sci.*, vol. 1, pp. 1344-1352, 2011.
- [2] Coffeeandhealth.com, 'All about coffee', 2011. [Online]. Available: <http://www.coffeeandhealth.org/all-about-coffee/instant-coffee/>. [Accessed: 9-Jul-2017]
- [3] P.C. Corrêa, O. Resende and D.M. Ribeiro, "Drying characteristics and kinetics of coffee berry," *Revista Brasileira de Produtos Agroindustriais*, vol. 8, pp. 1-10, 2006.
- [4] P.C. Corrêa, A.L.D. Goneli, P.C.A. Junior, G.H.H. de Oliveira and D.S.M. Valente, "Moisture sorption isotherms and isosteric heat of sorption of coffee in different processing levels," *Int. J. Food Sci. Technol.*, vol. 45, pp. 2016-2022, 2010.
- [5] H.J. Ciro-Velásquez, L.C. Abud-Cano and L.R. Pérez-Alegría, "Numerical simulation of thin layer coffee drying by control volumes," *DYNA*, vol. 77, pp. 270-278, 2010.
- [6] J. Muhidong, A. Rahman and Mursalim, "The effect of air flow rate on single-layer drying characteristics of Arabica coffee," *Int. Food Res. J.*, vol. 20, pp. 1633-1637, 2013.
- [7] E. Narváez and R. Solís, "Design of an experimental plant for instant coffee drying in closed-cycle," Diploma Thesis, Faculty of Chemical Engineering, National University of Engineering (UNI), Managua, Nicaragua, 2001.
- [8] R. Mendieta, M. Haerinejad and A. Picado, "Determination of suitable thin-layer drying models for brewer's yeast (*Saccharomyces cerevisiae*)," *Nexo*, vol. 28, pp. 58-66, 2015.
- [9] Z. Erbay and F. Icier, "A review of thin layer drying of foods: theory, modeling, and experimental results," *Crit. Rev. Food Sci. Nutr.*, vol. 50, pp. 441-464, 2009.
- [10] J. Crank. *The Mathematics of Diffusion*; Oxford University Press: Oxford, 1975.
- [11] R.M.V. Alves and M.R. Bordin, "Estimativa da vida útil de café solúvel por modelo matemático," *Food Sci. Technol.*, vol. 18, pp. 19-24, 1998.

- [12] ASABE, "Thin-layer drying of agricultural crops," ASABE Standard ANSI/ASAE S448.2., American Society of Agricultural and Biological Engineers, 2014.
- [13] H.W. Xiao, C.L. Pang, L.H. Wang, J.W. Bai, W.X. Yang and Z.J. Gao, "Drying kinetics and quality of Monukka seedless grapes dried in air-impingement jet dryer," *Biosyst. Eng.*, vol. 105, pp. 233-240, 2010.