

Aggregative mathematical model for the functioning of the monitoring system and warning of troops about emergencies at potentially dangerous objects

Volodymyr Kotsiuruba ^{*A}; Aleksii Blekot ^A;
Volodymyr Koval ^B; Evgen Levischenko ^B

^{A*}Corresponding author: Doctor of Technical Sciences, Professor, Honored Inventor of Ukraine, Professor of the Department,
e-mail: kotcuru@ukr.net, ORCID: 0000-0001-6565-9576

^ANational Defence University of Ukraine named after Ivan Cherniakhovskiy, 28, Povitroflotsky Ave., Kyiv, Ukraine

^BMilitary Scientific Directorate of the General Staff of the Armed Forces of Ukraine, 28, Povitroflotsky Ave., Kyiv, Ukraine

Received: December 02, 2020 | Revised: December 17, 2020 | Accepted: December 31, 2020

DOI: 10.5281/zenodo.4482723

Abstract

The article proposes an aggregate mathematical model for the functioning of monitoring the system and warning of troops (forces) about emergencies at potentially dangerous objects. The main purpose of monitoring the system and warning troops (forces) about emergencies at potentially dangerous objects is to ensure the survivability and preservation of the capabilities of troops (forces). To build an adequate aggregative mathematical model of the relationship between the system and military formations, it is necessary to assess the effectiveness of monitoring and warning capabilities, the state of readiness of military units due to accidents and emergency situation, the availability of resources and so on. The proposed model is endowed with general characteristics, but in the absence of a certain set of interacting external factors, it can be easily transformed into a model of an effective system for facilities after some research.

Key words: system, dangerous, aggregative, model, military.

Introduction

An analysis of the current military and political situations in recent years clearly shows that military conflicts have become increasingly combined (“hybrid”), as they integrate various forms and methods to use military forces in “traditional” war, internal armed conflicts, information warfare, terrorism, and organized crime, etc (Analychna dopovid; Tkach I. M., 2018; Karpenko, N., 2020). The history of local wars and armed conflicts suggests that industrial, energy, transport and military potentially hazardous facilities (hereinafter – the Facilities) with the

beginning of the armed confrontation can be destroyed both intentionally and unintentionally. With a significant number of facilities located in Ukraine (Informatsiini materialy; Duz-Kriatchenko O. P., 2015), it may be necessary to establish an effective monitoring and early warning system to warn military forces of emergencies at potentially hazardous facilities (hereinafter – the System). Making progress towards this goal it requires the development of an appropriate mathematical model for the System, and this confirms the relevance of this topic.

Material and methods

General approaches and aspects used to build such a system for facilities are discussed in a number of scientific papers (Stryzhevskiy V. V., 2007; Grechaninov V. F.; Mykhailova A. V., 2020; Bondar O. I., 2019). These works discuss only

certain processes applied in monitoring and warning of emergencies at facilities, but they are fragmented and do not allow to assess the impact on the implementation of combat capabilities. Using this approach, a number of challenges arise

in assessing potential models for implementing such a system at facilities. Therefore, the aim of the article is to develop an aggregative

mathematical model of the system to be used at facilities as an appropriate subsystem to ensure the use of military capabilities.

Results and discussion

The system to be used at facilities in relation to the higher-level system is a subsystem. Key military capabilities that take advantage of this system at facilities include firepower, maneuverability and strike capabilities (Sharyi V. I., 2000; Buslenko N. P., 1973).

This system is a multilayered system where the lower echelon has the appropriate monitoring and early warning capabilities to warn the military of emergencies at the facilities, and the upper echelon is dedicated to command and control (C2) to ensure the collection of information on emergencies at the facilities, provide analysis, assessment, and decision-making on the use of military forces in the event of accidents (emergency situation), and disseminate alerts.

For the upper echelon, the key role of the System is to ensure survivability and protection of military capabilities (Sharyi V. I., 2000). Depending on the chosen architecture of the system, it can perform various monitoring and notification functions, which can be presented as an unregulated flow of events, most of which are random. In such circumstances, the performance evaluation of such a system requires the use of a number of indicators that represent the various characteristics of the system, which is a complex organizational and technical system.

To build an adequate aggregative mathematical model of the relationship between the system and military formations, it is necessary to assess the effectiveness of monitoring and warning capabilities, the state of readiness of military units due to accidents and emergency situation, the availability of resources and so on.

Analysis of some well-known methods applied in aggregative mathematical modeling of complex systems shows that the most appropriate method for modeling of this category system is an aggregative modeling tool [9]. In addition, we do not have generally

accepted rules that are designed to optimally decompose any complex system, and allow all components of the system to be defined as individual aggregates. There is an assumption that progress towards this goal requires creativity and a high level of professionalism.

Since the key role of the system at facilities is to provide opportunities for the use of military capabilities in the event of accidents (emergency situation), individual aggregates (units) of the system should be considered as system components that are suitable for autonomous, theoretical and experimental research, and their links to other parts are clear and easily imaginable as a finite set of independent routes for the transmission of impacts applicable for modeling:

Unit A_e – external exposure (environment, enemy, Facilities, etc.);

Unit A_r – readiness of military units in emergency situations;

Unit A_c – control processes;

Unit A_s – facilities status assessment;

Unit A_{aw} – emergency alert and warning.

A unit is a facility characterized by its internal status $Z(t)$, input signal $x(t)$, control signal $g(t)$, output signal $y(t)$, and transition operators for H statuses and G outputs.

$$Z(t + 0) = H\{t, Z'(t + 0), g(t), x(t)\}, \quad (1)$$

Where, H – state operator; t – time parameter of operation for the monitoring system of conditions and warning of an emergency situation on potentially dangerous objects; $Z'_{(t+0)}$ – original condition monitoring system and emergency warning; $g(t)$ – output; $x(t)$ – input signal.

In turn, the output operator determines the output signal, which depends on the unit internal status and unit control signal

$$y(t) = \begin{cases} G\{t, Z(t), g(t)\}, & Z(t) \subset Z_g^\omega \\ 0, & Z(t) \notin Z_g^\omega \end{cases} \quad (2)$$

Where, G – signal output operator; Z_g^ω is the

set of unit internal statuses that issue output signals; $Z(t)$ – the current dynamic internal state of the monitoring and warning system.

The moment t_i for the release of the next non-empty output signal is determined by the operator

$$t_i = G\{t_i, Z(\tau), g(\tau), x(\tau)\},$$

$$t_{i-1} < \tau \leq t_i, \tag{3}$$

where, τ – the actual fixed time of the control signal; t_{i-1}, t_i are adjacent elements to the sequentially ordered in time moments when unit issues output signals.

In addition, the aggregate system model for the facilities can be represented as the structure shown in the figure below.

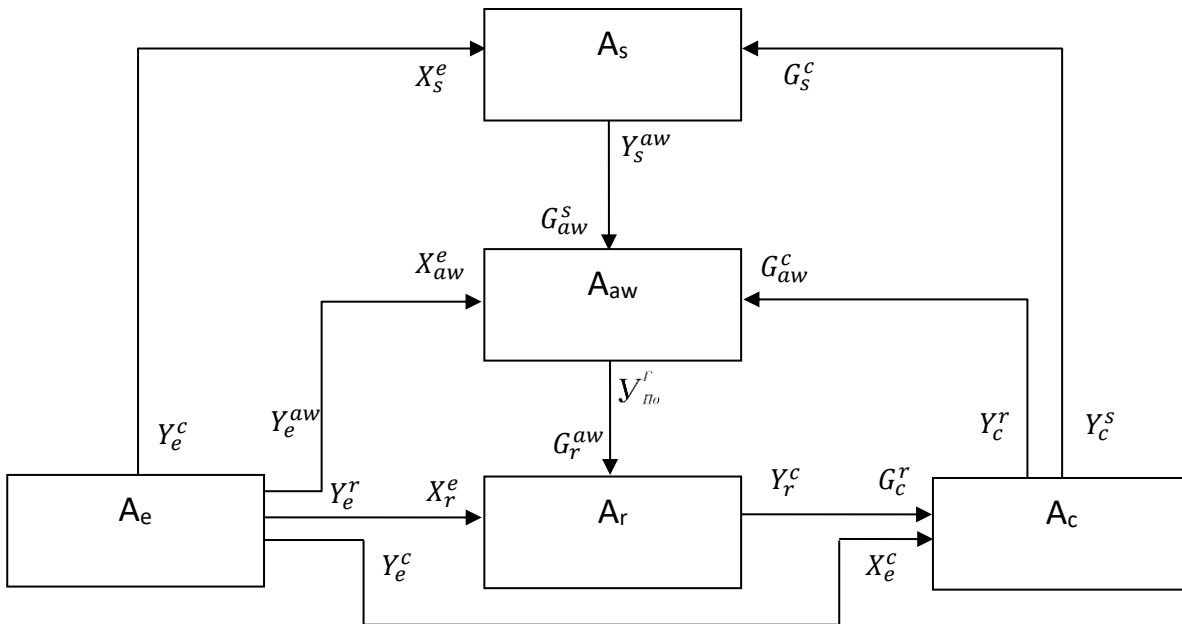

Figure – Structure of the aggregate mathematical model for the facilities

The aggregative system model for facilities can be considered as a set of relevant facilities. Given the provisions set out in (Buslenko N. P.,

1973), each facility needs to identify a number of performance indicators that meet the required variables (requirements) in the ratio:

$$W_r = F[B_1(t), B_2(t), \dots, B_j(t), \dots, B_{j^*}(t)], t \in (0, T), \tag{4}$$

where $B_j(t) = [\beta_{j1}(t), \beta_{j2}(t), \dots, \beta_{j\nu}(t)]$ is a vector of variables that characterize the ability of the j -facility to use its capabilities as part of the assigned forces;

$j \in (1, j^*)$ is a serial number of the j -facility as part of the assigned forces;

T – is the time period in question;

ν – is the number of variables that identify the combat power (firepower, maneuverability and strike capabilities) of the assigned forces before their mission.

In the shown aggregative model of external exposure, the status of assigned forces during potential accidents at facilities, control,

monitoring, and *emergency alerts* are set by the respective units $A_e, A_r, A_c, A_s, A_{aw}$ and the defined program.

Changes made in the variables of the model units are based on the lessons from combat operations, tactical exercises and the environment, which is simulated for the use of the system at facilities. The processes which are simulated in the model can be reproduced by entering the appropriate indicators or can be generated by sensors of random numbers provided that the change in variables influenced by external and internal random factors is known.

Conclusions

The proposed aggregate mathematical model encompasses possible effects of the system on military capabilities at facilities, reveals its major components, which are subject to autonomous, theoretical and experimental research. The proposed model is endowed with general characteristics, but in the absence of a

certain set of interacting external factors, it can be easily transformed into a model of an effective system for facilities after some research. Further research may be based on the continuous improvement approach to be applied in justifying a cost-effective System design.

References

- Analitichna dopovid do shchorichnoho Poslannia Presydena Ukrainy do Verkhovnoi Rady Ukrainy "Pro vnutrishnie ta zovnishnie stanovyshe Ukrainy v 2018 rotsi" 2018. S. 516–517. Available from: <http://www.niss.gov.ua/articles/3143/>.
- Bondar O. I., Mashkov O. A., Hannenko S. O., Zhukauskas S. V., Nihorodova S. A. Otsinka mozhyvosti vykorystannia kosmichnykh aparativ dlia provedennia ekolohichnoho monitorynhu: zb. tez dop. VI vseukr. zizdu ekolohiv z mizh. uchastiu VNTU. Vinnytsia, 2019. S.103.
- Buslenko N. P., Kalashnikov V. V., Kovalenko I. N. Lektsii po teorii slozhnykh system. *Sovetskoe radio*, 1973. s. 440.
- Duz-Kriatchenko O. P. Osnovy strategii natsionalnoi bezpeky ta oborony derzhavy: pidruchnyk / O.P. Duz-Kriatchenko, Rusnak I.S, Punda Yu. B., V.P. Hryshchenko, P.M. Hrytsai, V. M. Hudym, Yu. H. Danyk, V. I. Yefimenko ta in. Kyiv: NUDU, 2015. 620 s.
- Grechaninov V. F. Rekomendatsii shchodo funktsionuvannia yedynoi derzhavnoi systemy tsyvilnoho zakhystu v umovakh (persha redaktsiia) / V. F. Hrechaninov /Ukr. nauk.-doslid. in-t tsyvil. zakhystu. Available from: <http://undiczs.dsns.gov.ua/files/2016/8/30>.
- Informatsiini materialy do 5-richchia vid pochatku zbroinoi ahresii Rosiiskoi Federatsii proty Ukrainy. URL: <https://uinp.gov.ua/informaciyni-materialy/viyskovym/do-5-richchya-vid-pochatku-zbroynoyi-agresiyi-rosiyskoyi-federatsiyi-proty-ukrayiny>
- Karpenko, N., & Tkach, I. (2020). Geopolitical perspectives of the triangle "Kyiv – Minsk – Nur-Sultan", situated on the Chinese "Silk Road" under the "American umbrella". *Political Science and Security Studies Journal*, 1(1), 55–60. Available from: <https://doi.org/10.5281/zenodo.4284602>
- Mykhailova A. V. Systema monitorynhu ta poperedzhennia pro nadzvychaini sytuatsii v zoni provedennia operatsii obiednanykh syl: dys.kand.tekh.nauk: 21.02.03. Kyiv, 2020. 236 s.
- Sharyi V. I., Nevolnichenko A. I. Problematyka keruvannia sferoiu voiennoi bezpeky. Nauka i oborona. Kyiv, 2000. № 1. S. 16–21.
- Stryzhevskiy V. V., Muzychenko D. P. Nadzvychaini sytuatsii pryrodnoho ta tekhnogenogo kharakteru. Uchast formuvan sukhoputnykh viisk zbroinykh syl Ukrainy u likvidatsii naslidkiv nadzvychainykh sytuatsii pryrodnoho ta tekhnogenogo kharakteru: Navch. posib. Kyiv : NAOU, 2007. 58 s.
- Tkach I. M. Conceptual principles of military and economic security of the state: monograph. Kyiv, 2018. 312 p.