

60 GHz Microstrip Van Atta Arrays for Millimeter Wave Identification and Localization

K. Trzebiatowski¹, M. Rzymowski², *Member, IEEE*, L. Kulas³, *Senior Member, IEEE*, and K. Nyka⁴, *Senior Member, IEEE*
Department of Microwave and Antenna Engineering,
Faculty of Electronics, Telecommunications and Informatics, Gdansk University of Technology
Gdansk, Poland

¹kamil.trzebiatowski@pg.edu.pl, ²mateusz.rzymowski@pg.edu.pl, ³lukasz.kulas@pg.edu.pl, ⁴krzysztof.nyka@pg.edu.pl

Abstract—In this paper performance comparison of co-polarized and cross-polarized microstrip Van Atta arrays working in the 60 GHz frequency range is presented. They can be treated as simple chipless RFID tags with frequency response based identification. Tags with three different nominal resonance frequencies of 57, 62 and 67 GHz are designed by scaling optimized base model. Designed 62 GHz co-polarized and cross-polarized arrays with four interconnected pairs of elementary antenna arrays have small dimensions of 20 x 18 mm and 36 x 23 mm, and exhibit RCS levels of -20 and -22 dBsm, respectively. The influence of number of interconnected antennas on the radar cross-section (RCS) of the tag is investigated. Frequency responses of the tags are also examined and compared for both types of tags with 0.80 GHz (co-polarized) and 2.10 GHz (cross-polarized) 3 dB bandwidth of the RCS response at 60 degree interrogation angle.

Keywords—Van Atta array, retrodirective array, radar cross-section (RCS), chipless radio-frequency identification (RFID), millimeter wave identification (MMID), localization

I. INTRODUCTION

Millimeter wave identification systems (MMID) are developed as an extension of radio frequency identification systems (RFID) to the bands above 20 GHz, notably the unlicensed 60 GHz ISM band [1]. The advantages of using millimeter waves lie in broader available bandwidth, lower interferences from other signal sources (as these bands are rarely occupied) and smaller possible sizes of the readers and RFID tags. They can also provide increased precision of RFID localization systems due to small wavelength and more directive antennas [2][3].

The major factor in any RFID system is the cost of tags. They usually have to be as cheap as possible yet with the increase of frequency to the millimeter wave range the production costs rise quickly due to the need of more sophisticated integrated circuits embedded in the tag. For this reason chipless MMID tags are proposed as an alternative solution lacking any integrated chips thus reducing production costs significantly [3][4].

The challenge with chipless tags is to establish a way to store information and to allow reader to retrieve it without the use of integrated circuits. This capability is achieved by encoding information in the tag's reflection characteristics [4] usually measured by the radar cross-section (RCS) parameter. The RFID tag is interrogated by the reader and the backscattered signal is altered according to data stored in the tag, for example the information can be embedded in the frequency

response [4]. An implementation example [4] presents a tag which comprises interconnected receiving and transmitting antennas with a number of resonators coupled with the interconnecting lines. The data bits are stored in the presence or absence of resonance peaks at predefined frequency positions. This simple tag uses only one receiving and one transmitting antenna which makes such a disadvantage that the reflectivity of the tag is very much dependent on the angle of incidence.

To overcome the limitations related to narrow interrogation angle and low reflection coefficient, Van Atta arrays were proposed [5]-[7] which re-radiate incident waves back in the direction of their arrival independently of the angle of incidence. For this reason a high level of RCS with small variations in a wide angle of interrogation can be obtained. Typical Van Atta arrays reflect waves preserving their polarization but in [6] a millimeter wave planar Van Atta array is proposed that changes polarization of a reflected signal to orthogonal. This feature allows for increasing signal-to-clutter-interference-ratio [6] of the signal received by the reader as the unwanted reflections from the tag's environment are usually co-polarized. The disadvantage of this solution is that the reader has to use two orthogonally polarized antennas or a single antenna with switchable polarization.

Both aforementioned types of Van Atta arrays can be used in chipless RFID systems yet the literature lacks any comparison of their characteristics, especially in the 60 GHz band proposed for MMID systems. Passive co-polarized Van Atta array designed for this band was presented in [7] but no comparable simulation or measurement results were provided and to the best of the authors' knowledge the concept of cross-polarized microstrip Van Atta arrays was not investigated in this band before. Therefore, in this paper we present comparison of the design and performance of co-polarized and cross-polarized one-dimensional microstrip Van Atta arrays with different spectral signatures in the 60 GHz band. Tags are designed for use in millimeter wave localization and object classification systems.

II. VAN ATTA ARRAY DESIGN

The design of two different types of microstrip Van Atta arrays is presented. The tags are designed to be fabricated on a flexible RT/duroid 5880 substrate having a relative permittivity of 2.20, low loss tangent of 0.001 and thickness of 0.127 mm.

A. Co-polarized Array

The proposed co-polarized Van Atta array is composed of N pairs of interconnected linear arrays as shown in Fig. 1. A single linear array consists of four series-fed square microstrip patches. The patch sizes D and spacing between them L_y are chosen to achieve single array's input impedance of about 50 Ohm at the resonance frequency.

This work was supported in part by the AFARCLOUD Project through the ECSEL Joint Undertaking (JU) under grant agreement No 783221 and in part by the European Union's Horizon 2020 research and innovation programme and Austria, Belgium, Czech Republic, Finland, Germany, Greece, Italy, Latvia, Norway, Poland, Portugal, Spain, Sweden.

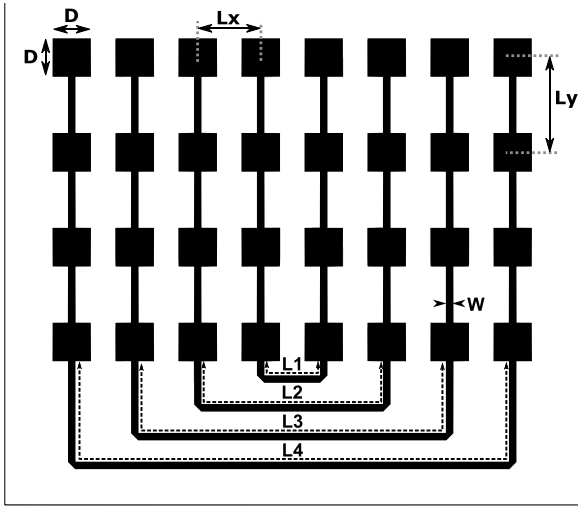

Fig. 1. Co-polarized Van Atta array with $N = 4$ pairs of interconnected linear arrays; see text and Table I for explanations.

The arrays are spaced by L_x from each other and are interconnected by microstrip lines of width W and length L_n ($n = 1.. N$). The lengths of the subsequent interconnecting lines differ in multiples of guided wavelength λ_g so all the arrays are fed in-phase.

The final dimensions were optimized using Global Response Surface Method available in Altair FEKO environment. The target function was to maximize monostatic radar cross-section level over the $(-60^\circ, 60^\circ)$ angle range of incident wave direction. Optimization was performed for the array with resonance frequency equal to 62 GHz and $N = 4$ pairs of interconnected linear arrays. Two other versions of the array for the frequencies of 57 GHz and 67 GHz were obtained by rescaling original design with respect to the change of wavelength. The final dimensions of co-polarized Van Atta arrays are presented in Table I.

TABLE I. DIMENSION VALUES OF THE DESIGNED CO-POLARIZED VAN ATTA ARRAY

Dimension	Value	Description
λ_0	at 57 GHz	5.263 mm
	at 62 GHz	4.839 mm
	at 67 GHz	4.478 mm
		Wavelength in free space
λ_g	$0.7522 \lambda_0$	Guided wavelength
D	$0.405 \lambda_g$	Size of a patch antenna
L_x	$0.5 \lambda_0$	Spacing of linear antenna arrays
L_y	λ_g	Spacing of microstrip patches in a linear array
L_1	λ_g	Length of the first interconnecting line
L_n	$(2n-1) \lambda_g$	Length of the n -th interconnecting line
W	0.30 mm	Width of the microstrip line

B. Cross-polarized Array

The cross-polarized array, presented in Fig. 2, is designed in a similar manner to the co-polarized one. The main difference is that the interconnections are made to change polarization of re-emitted electromagnetic wave to orthogonal [6].

The array consists of N pairs of microstrip arrays spaced by L_x from each other, counting the self-connected center array as one pair. A single array comprises four microstrip

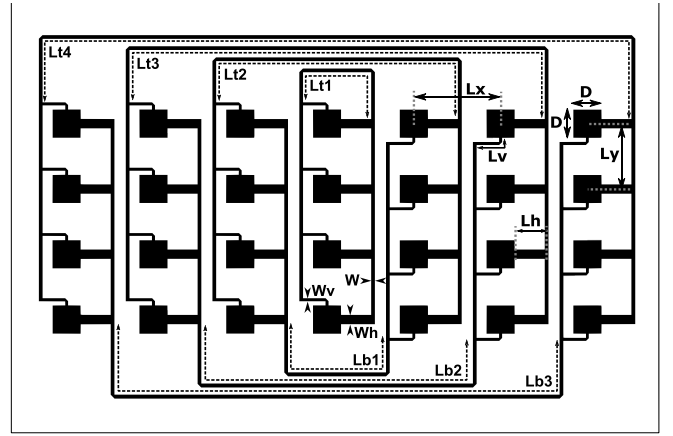

Fig. 2. Cross-polarized Van Atta array with $N = 4$ pairs of interconnected linear arrays; see text and Table II for explanations.

patches with distance L_y between them and side length D that can be fed from two orthogonal sides. For this reason a single array has two opposite polarization ports that can be used to excite two orthogonal modes. The side feed lines have widths of W_h and W_v , and lengths of L_h and L_v , equal to about $\lambda_g/2$. The input impedance of a patch is transformed through these lines to the main feed lines of width W (for both polarization cases) which connects the four patches. As a result, the array, as seen from a single polarization port, works similarly to the series-feed one used in the co-polarized tag.

The interconnecting lines join opposite polarization ports of two arrays to obtain cross-polarized reflection response. There are N lines interconnecting the arrays from the top with lengths L_m and $(N-1)$ from below with lengths L_{bn} . The patches on the right have vertical feed ports at the bottom edge so the lengths L_{bn} are increased by half-wavelength compared to L_m to ensure that all arrays are excited in-phase [6].

The optimization procedure and the design of three tags with different resonance frequencies were carried out like in the co-polarized tag case. The final dimensions of cross-polarized Van Atta arrays are presented in Table II.

TABLE II. DIMENSION VALUES OF THE DESIGNED CROSS-POLARIZED VAN ATTA ARRAY

Dimension	Value	Description
λ_0	at 57 GHz	5.263 mm
	at 62 GHz	4.839 mm
	at 67 GHz	4.478 mm
		Wavelength in free space
λ_g	$0.7522 \lambda_0$	Guided wavelength
D	$0.427 \lambda_g$	Size of a patch antenna
L_x	λ_0	Spacing of linear antenna arrays
L_y	λ_g	Spacing of microstrip patches in a linear array
L_v	$0.446 \lambda_g$	Vertical feed microstrip line length
L_h	$0.497 \lambda_g$	Horizontal feed microstrip line length
L_m	$2 \lambda_g + 3(n-1) \lambda_g$	Top interconnecting lines length
L_{bn}	$2.45 \lambda_g + 3(n-1) \lambda_g$	Bottom interconnecting lines length
W	0.195 mm	Microstrip patch feed line width
W_v	0.150 mm	Vertical feed microstrip line width
W_h	0.50 mm	Horizontal feed microstrip line width

III. NUMERICAL RESULTS

Numerical simulations were carried out in the Altair FEKO environment. In the beginning, the impact of a number of interconnected linear array pairs (N) on the monostatic radar cross-section characteristics is investigated for both the co-polarized and cross-polarized Van Atta arrays as shown in Fig. 3 and Fig. 4.

It can be seen that RCS of a tag rises with N at a cost of increasing the ripple level. The gains from increasing N (in terms of the RCS level) are smaller as the size of the tag becomes bigger due to the fact that the interconnecting lines become longer and losses in them become more significant. This effect is especially visible in the cross-polarized array which has almost twice as many lines as the co-polarized tag. Another consequence of increasing the tag's number of interconnected antennas is the increase of the 3 dB angular range of the radar cross-section.

Sizes of the tags corresponding to the values of N are presented in Table III. The cross-polarized tags are bigger than co-polarized ones for the same number of interconnected array pairs due to higher distances between elementary arrays (L_x) which are needed to make place for orthogonal interconnections.

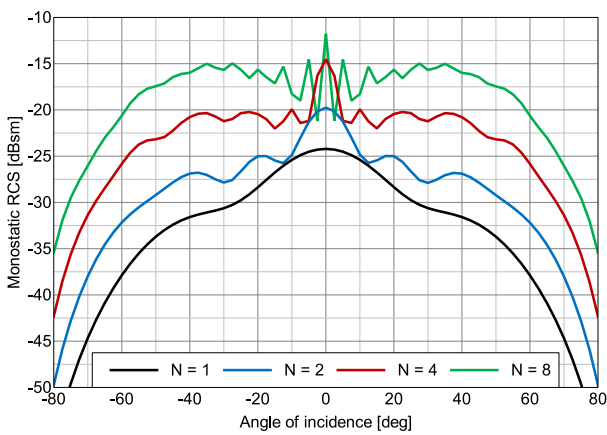

Fig. 3. Impact of number N of linear pair arrays on the RCS characteristic for co-polarized array with nominal resonance frequency of 62 GHz.

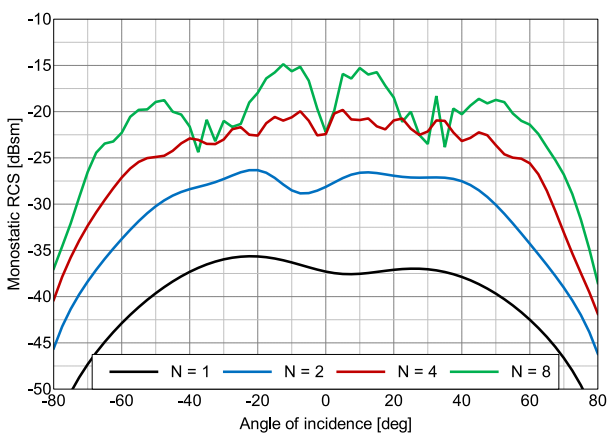

Fig. 4. Impact of number N of linear pair arrays on the RCS characteristic for cross-polarized array with nominal resonance frequency of 62 GHz.

TABLE III. SIZES OF THE INVESTIGATED ARRAYS

N	Co-polarized tag size (62 GHz)	Cross-polarized tag size (62 GHz)
1	7 mm x 15 mm	6 mm x 17 mm
2	10 mm x 16 mm	16 mm x 20 mm
4	20 mm x 18 mm	36 mm x 23 mm
8	40 mm x 23 mm	75 mm x 27 mm

Further examinations were performed using four-pair Van Atta arrays. The responses of both types of Van Atta arrays at the resonance frequency are compared in Fig. 5. As one can see, the co-polarized array's characteristic is more rippled than the cross-polarized one. Also, it has a slightly higher average RCS level and a visible peak for orthogonal incidence. The angular ranges are similar for both arrays with the cross-polarized tag's RCS being about 20 degrees wider due to lower ripples.

The frequency responses of designed Van Atta arrays were also investigated. Two spectral responses of the cross-polarized tags are presented in Fig. 6 with visible resonances at the design frequencies. It can be seen that responses from both tags have similar shapes for both plotted angles of incidence, so identification could be possible in the wide range of incident angles. The 3 dB bandwidth of RCS level is rather large and approximately equals 2 GHz.

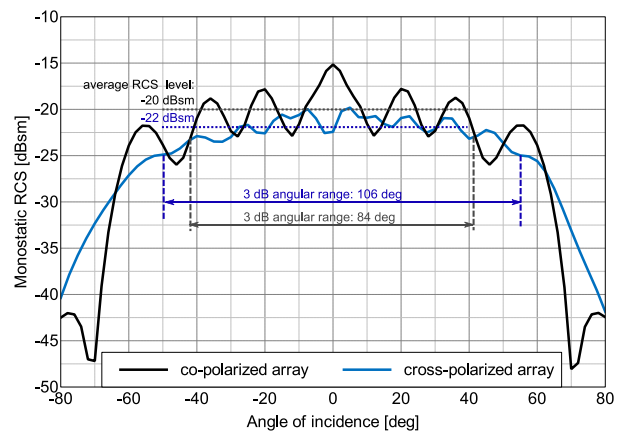

Fig. 5. Comparison of RCS of co-polarized and cross-polarized arrays with 62 GHz nominal resonance frequency ($N = 4$)

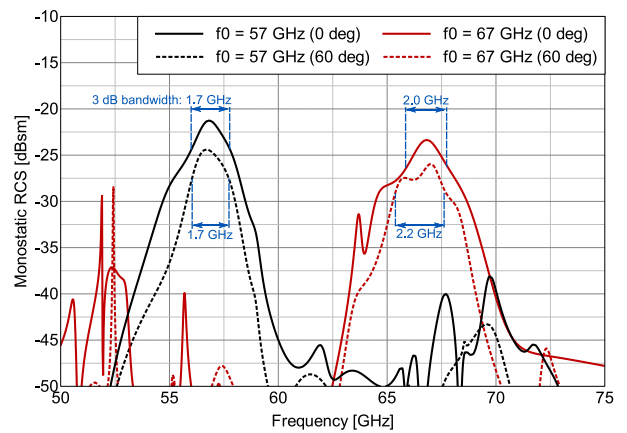

Fig. 6. Frequency responses of cross-polarized arrays ($N = 4$) with nominal resonance frequencies f_0 of 57 and 67 GHz for angle of incidence equal to 0 and 60 degrees.

The co-polarized arrays' frequency responses are shown in Fig. 7 for tags with design resonance frequencies of 57 GHz and 62 GHz. The shifts from nominal frequencies are visible as the arrays were optimized using infinite substrate approximation and the final simulations are performed with a finite substrate model. Comparison of frequency responses for both types of arrays is presented in Fig. 8. Table IV contains summary of simulated basic parameters of the co-polarized and cross-polarized tags.

The co-polarized tag has a very different response to the cross-polarized one when the angle of incidence is normal to the surface of the array. It is almost equal to that of a flat conducting plate (with the size equal to the size of the tag) except for a resonance minimum near the design frequency. This effect does not occur with the cross-polarized tags as it is caused by co-polarized reflection from the tag's ground plane. The characteristics of both types of the tags are similar to each other for the angles of incidence different from 0 degrees. The RCS response at the angle equal to 60 degrees is close for both the co-polarized and cross-polarized tags at their resonance frequencies except for the fact that the co-polarized arrays exhibit narrower frequency response compared to the cross-polarized arrays, as they have 3 dB RCS bandwidth of about 1 GHz.

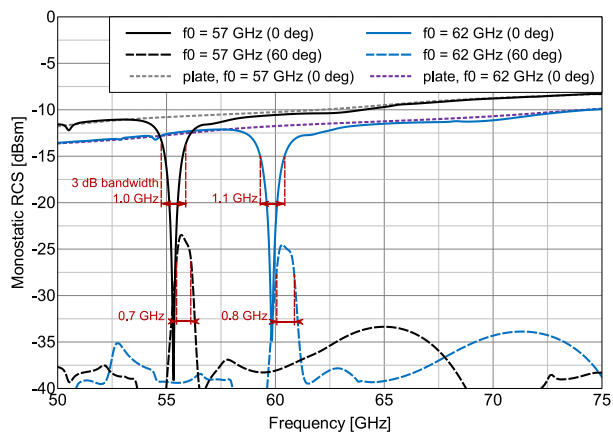

Fig. 7. Frequency responses of co-polarized arrays ($N = 4$) with nominal resonance frequencies f_0 of 57 and 62 GHz for angle of incidence equal to 0 and 60 degrees compared to RCS of flat conducting plates with sizes equal to sizes of the tags.

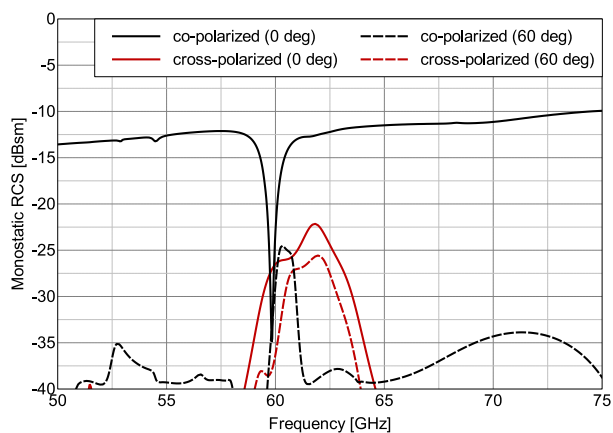

Fig. 8. Comparison of frequency responses of co-polarized and cross-polarized arrays ($N = 4$) with nominal resonance frequency of 62 GHz for angle of incidence equal to 0 and 60 degrees.

TABLE IV. SIMULATED PARAMETERS OF THE DESIGNED TAGS ($N = 4$, $F_0 = 62$ GHz)

Parameter	Co-polarized array	Cross-polarized array
Maximum RCS value [dBsm] at resonance frequency	-15.2	-19.9
Average RCS value [dBsm] calculated in the $(-40^\circ, 40^\circ)$ angle range	-20	-22
RCS ripple level [dB] in the $(-40^\circ, 40^\circ)$ angle range	5	2.5
3 dB RCS angular range [deg] at resonance frequency	84	106
3 dB RCS bandwidth [GHz] at 0 deg	1.1	1.8
3 dB RCS bandwidth [GHz] at 60 deg	0.8	2.1
Tag size [mm x mm]	20 x 18	36 x 23

IV. CONCLUSION

In this work, co-polarized and cross-polarized 60 GHz Van Atta arrays for chipless millimeter wave identification and localization are presented and their characteristics in terms of angle and frequency responses are compared. Both types of chipless tags have their advantages. Co-polarized tags exhibit greater RCS with smaller physical dimensions as well as narrower frequency response which can be positive when there is a need for a large number of different frequency signatures. Cross-polarized arrays can be read or localized from a wider range of angles due to the more uniform RCS characteristic. On the other hand, both tags have disadvantages: the reflections from the array's surrounding are co-polarized and can interfere with the co-polarized tag's response whereas the cross-polarized tags need a RFID reader than can work with two orthogonal polarizations. Compared to the arrays working in lower frequency ranges, designed tags exhibit similar characteristics and RCS levels with much smaller physical sizes.

The next stage of the presented works is to manufacture the designed Van Atta arrays and measure their characteristics in a millimeter wave anechoic chamber to confirm conclusions presented in this paper. Tests in a real reflective environment are also to be performed. These experimental results will be presented at the conference.

ACKNOWLEDGMENT

The authors would like to thank the Academic Computer Centre in Gdansk, Poland (TASK) where all the calculations were carried out.

REFERENCES

- [1] P. Pursula et al., "Millimeter-wave identification—A new short-range radio system for low-power high data-rate applications," in *IEEE Trans. Microw. Theory Techn.*, vol. 56, no. 10, pp. 2221-2228, Oct. 2008.
- [2] R. Miesen et al., "Where is the tag?," in *IEEE Microw. Mag.*, vol. 12, no. 7, pp. S49-S63, Dec. 2011.
- [3] R. Anee and N. C. Karmakar, "Chipless RFID tag localization," in *IEEE Trans. Microw. Theory Techn.*, vol. 61, no. 11, pp. 4008-4017, Nov. 2013.
- [4] S. Preradovic and N. C. Karmakar, "Chipless RFID: Bar code of the future," in *IEEE Microw. Mag.*, vol. 11, no. 7, pp. 87-97, Dec. 2010.
- [5] E. Sharp and M. Diab, "Van Atta reflector array," in *IRE Trans. Antennas Propag.*, vol. 8, no. 4, pp. 436-438, July 1960.
- [6] J. G. D. Hester and M. M. Tentzeris, "Inkjet-printed flexible mm-wave van-atta reflectarrays: A solution for ultralong-range dense multitag and multisensing chipless RFID implementations for IoT smart skins," in *IEEE Trans. Microw. Theory Techn.*, vol. 64, no. 12, pp. 4763-4773, 2016.
- [7] V. F. Fusco, D. Salameh, and T. Brabetz, "Integrated antennas for millimeter-wave asset tracking," in *Proc. IEE Semin. Integr. Miniaturized Antenna Technol. Asset Tracking Appl.*, Jan. 2000.