

“© 2020 IEEE. Personal use of this material is permitted. Permission from IEEE must be obtained for all other uses, in any current or future media, including reprinting/republishing this material for advertising or promotional purposes, creating new collective works, for resale or redistribution to servers or lists, or reuse of any copyrighted component of this work in other works.”

Traceable Characterization of Low Power Voltage Instrument Transformers for PQ and PMU Applications

G. Crotti*, A. Delle Femine[✉], D. Gallo[✉], D. Giordano*, C. Landi[✉], P.S. Letizia^{*†} and M. Luiso[✉]

^{*}Istituto Nazionale di Ricerca Metrologica (INRiM), Torino, Italy

[✉]Dept. of Engineering, University of Campania “Luigi Vanvitelli”, Aversa (CE), Italy

[†]Politecnico di Torino, Torino, Italy
p.letizia@inrim.it

Abstract — Diffusion of digital technologies in transmission and distribution substations is fostering utilization of low power instrument transformers for use in metering, protection, as well as in monitoring and control applications. From the metrological point of view, new reference systems and procedures are needed to ensure traceable measurement, in particular when these low power sensors are coupled with phasor or power quality measurement unit, to identify their uncertainty contribution in the evaluation of the output parameters. In this scenario, a reference set-up for the characterization of voltage sensors with analog or digital output is described. First examples of characterization of a low power voltage transformer in presence of dynamic and power quality signals are shown.

Index Terms — Low power instrument transformer, power grid, power quality, phasor measurement unit, uncertainty.

I. INTRODUCTION

Implementation of digital technologies in transmission and distribution substations is fostering the use of a new generation of voltage and current sensors, which can be used for metering purposes as well as for monitoring grid conditions and quality of the transferred power. From the metrological point of view, new reference systems and procedures are needed to ensure accurate and traceable measurement in particular when these sensors are coupled with phasor measurement units (PMU) or power quality measurement units (PQMU), to identify their uncertainty contribution in the evaluation of the output quantities. In the following, activity developed within the EMPIR 17IN06 Future Grid II project is described, which focuses on features and performance of a modular generation and measurement reference set-up for the characterization under static and dynamic conditions of low power voltage instrument transformers (LPVT) with analog or digital output.

II. MEASUREMENT SETUP

A. Measurement Setup Description

A laboratory system for the performance evaluation of LPVTs with analog and digital output by comparison with a reference sensor is developed (Fig. 1), starting from the one described in [1]. The system is based on a National Instruments

(NI) PCI extension for instrumentation (PXI) platform. Different test waveforms are generated by an arbitrary waveform generator (AWG), (16 bit, ± 12 V, 200 MHz), and then amplified to provide high voltage waveforms up to ± 30 kV with frequency spectrum up to 20 kHz. The generated voltage is measured by a 30 kV reference divider built and characterized at INRIM [1]. The reference and test signals are acquired by a comparator that includes a NI compact data acquisition system (cDAQ) with various acquisition modules (from ± 0.5 V to ± 425 V). The software for data processing and instrument control is developed in LabVIEW[®]. A large variety of signals can be generated, such as sinusoidal, fundamental plus one or N harmonics, amplitude and phase modulated signals, frequency ramps, PQ events from database or user simulated. The 10 MHz PXI clock is used as a reference clock for AWG phase locked loop (PLL) circuitry and can also be employed to obtain the master time base of the comparator device. This clock can be substituted by the one from the NI 6683H synchronization module, which can provide synchronization to absolute time via global positioning system (GPS), IEEE 1588, inter-range instrumentation group B (IRIG-B), or pulse per second (PPS).

B. Measurement Setup Characterization

The reference resistive-capacitive voltage divider has been calibrated at power frequency by comparison with a standard voltage transformer (VT) at $U_r=20/\sqrt{3}$ kV, obtaining a scale factor (SF) of 10169.44 V/V ± 0.55 V/V (95 % level of confidence, as all the uncertainties given in the following).

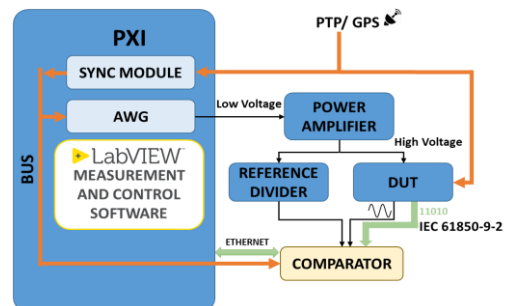

Fig. 1. Laboratory reference system: block diagram

Table I: Frequency Ramp test results

Measured Quantities	Mean Values	Standard Deviation	Limits for M class PMU
Ratio Error (%)	0.054	$5 \cdot 10^{-4}$	-
Phase Error (mrad)	7.45	0.010	-
TVE (%)	0.75	0.0011	1
FE (mHz)	0.0038	0.0027	5
RFE (mHz/s)	0.19	0.025	100

As regard the phase error, after correction of the systematic error, an uncertainty of $56 \mu\text{rad}$ is estimated. Linearity of the divider is within $\pm 75 \mu\text{V/V}$ from 1 kV to 30 kV. Frequency response is flat within $200 \mu\text{V/V}$ from 150 Hz to 9 kHz.

As regard the acquisition system, characterisation carried out with compensation of the systematic errors by channel swapping, gives uncertainties within $1 \mu\text{V/V}$ and $0.5 \mu\text{rad}$ for the ratio and phase error measurement respectively, when two channels of NI cDAQ 9239 ($\pm 10 \text{ V}$, 24 bit, 50 kHz) are used with comparable input voltage amplitudes. As to the generation system, the maximum difference in the Total Harmonic Distortion (THD) of input and output signals of the divider, measured up to 5 kHz, is lower than $3 \cdot 10^{-6}$.

III. MEASUREMENT SCENARIO

To evaluate the possible errors introduced by a LPVT when used to reduce voltage upstream a PMU or a PQMU, the same voltage signal is applied to the reference sensor and the LPVT under test. Their outputs are acquired by the comparator (Fig. 1) and processed by two identical and ideal devices, simulated by software, which implement PQMUs or PMUs algorithms. In case of PQMUs, the output quantities of the reference and test measurement path are the root mean square (rms) values refreshed each half-cycle; from these data, the parameters of interest for PQ events are evaluated. For the PMU tests, the outputs are the synchrophasors, from them ratio and phase error of the sensor are evaluated as well as others quantities as defined in [2], including total vector error (TVE), frequency error (FE) and rate of change of frequency error (RFE).

IV. TESTS DESCRIPTION AND EXPERIMENTAL RESULTS

As a first application of the developed measurement setup, the performances of a commercial gas-insulated divider are investigated. The device under test has a measuring range of $\pm 45 \text{ kV}$, rated SF of 10000 V/V, 1 MHz bandwidth and 0.2 % rated accuracy. The performance of the sensor is evaluated under two test conditions. First, a frequency ramp (FR) test for PMU dynamic compliance verification [2] is performed. The applied waveform is generated according to:

$$v_{FR}(t) = \sqrt{2} U \cos(2\pi f_0 t + \pi R_f t^2) \quad (1)$$

where U and f_0 are the rms voltage and the rated frequency, while R_f is the frequency ramp rate. For the considered test we set $U = 20/\sqrt{3} \text{ kV}$, $f_0 = 50 \text{ Hz}$, $R_f = 1 \text{ Hz/s}$ and the investigated ramp ranges from (50 to 55) Hz. Twenty segments of 5 s were acquired at 50 kHz; the synchrophasors are estimated via the interpolated discrete Fourier transform on an observation

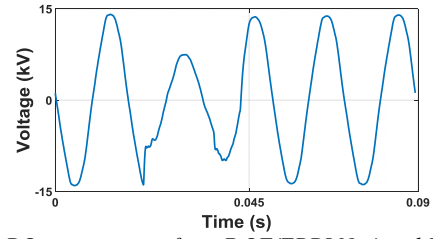

Fig. 2: PQ event extract from DOE/EPRI National Database.

interval of four cycles of the fundamental frequency with a reporting rate of 50 Hz. The FR test results are shown in Table I where they are compared with the limits stated for the M class PMUs. As regard the FE and RFE, mean values are far below the limits required by [2], while the TVE of the LPVT cannot be considered negligible with respect to the maximum error prescribed for the M class PMU. As a second example, a time-varying PQ disturbance (Fig. 2) from a database repository of power system events [3] is scaled to have a fundamental component amplitude $U_r = 20/\sqrt{3} \text{ kV}$ and reproduced by the reference set-up. The PQ event is classified as a voltage dip, so the residual voltage (U_{res}) and the dip duration t_{dip} are evaluated. According to [4], t_{dip} threshold is set to 90% of U_r , while the hysteresis is set to $2\% \cdot U_r$. The duration of the selected dip is 20 ms and its residual voltage is about 50% of U_r . As to the measured t_{dip} , no difference is detected between the reference value and the one from the LPVT. The relative deviation between the U_{res} provided by the LPVT and the reference one is equal to 0.21%. This deviation is quite close to the LPVT rated accuracy and, if compared to prescription for PQ measurement instruments, its absolute value is about half of the uncertainty required for class A instrument [4].

V. CONCLUSION

A measurement set-up for the evaluation of the error contribution of LPVTs when they are included in PMU/PQ measurement chains has been presented. First applications show that it can be used to verify the performance of LPVTs in presence of frequency ramps and actual voltage dips. As a future work, the use of the measurement system will be extended to characterization of different typologies of LPVTs, including those with digital output, in presence of disturbances with frequency spectrum up to 9 kHz.

ACKNOWLEDGEMENT

This project has received funding from the EMPIR programme co-financed by the Participating States and from the European Union's Horizon 2020 research and innovation programme.

REFERENCES

- [1] Cataliotti A. *et al.*, "Compensation of Nonlinearity of Voltage and Current Instrument Transformers", IEEE Trans. Instrum. Meas. IM, Vol. 68, No. 5, pp 1322-1332, May 2019.
- [2] IEEE Std C37.118.1-2011, pages 1– 61, Dec 2011
- [3] <https://pqmon.epri.com>
- [4] IEC 61000-4-30, Electromagnetic compatibility (EMC), 2015.