

Power Flow and Loss Analysis of Three Induction Motor Operating at Different Slip Conditions

P. Selvaraj, T. Muthukumari, Shaik Rafi Kiran*

*Department of Electrical and Electronics Engineering, Jeppiaar Institute of Technology,
Tamil Nadu, India*

**Corresponding Author*

E-Mail Id: selvaraj790518@gmail.com

ABSTRACT

In all type of industries Electric motors are used as main Electrical loads .It consumes more electrical energy .Hence it is important to ensure that these motors have been operated with minimum Power loss. During operating conditions of three phase induction motors, more factors are responsible for the reduction of motor performance characteristics .In three phase induction motor for a given out put power(provided by the manufactures), current drawn from the supply varies with respect to load conditions. This change in current makes the considerable change in air gap power, mechanical power, stator and rotor copper losses; by accurate calculation of various losses we can predict and obtain the required Efficiency of three phase induction motors. In this paper different losses were calculated for various Motor output power. From the obtained parameters Graphical representations of induction motor we can easily understand the importance of air gap power and mechanical power developed. Simulation of induction motor using MATLAB has been performed, the obtained results are presented.

Keywords: *Induction motor, slip, losses*

INTRODUCTION

Induction motor, recently many improvements have been made in the construction of induction of induction motors and more types of three phase and single phase induction motors have been developed. These motors are also called asynchronous motors .Various parts of three phases induction motor is shown in figure 1.since the speed is less than the rated speed. Due to its simple, rugged and easy construction .induction motor also has excellent operating characteristics .these motors are familiar in industrial use [1]. In general 80% of the induction motors are poly phase induction motors, the remaining motors are single phase type induction motors. When the three phase stator windings are energized with the three phase balanced AC supply, the rotating flux wave will be produced .If the rotating flux links with the rotating rotor

conductors. Three phase EMF will be generated .Due to the short circuited rotor conductors, the current will flows in the closed path which is known as rotor current. Interaction of the rotor flux with the stator flux produces rotor torque. This developed torque rotates the rotor in the direction of rotating magnetic field. Let n be the speed of rotor flux and n_s be the speed of the stator flux. The value of n is always less than n_s .

The relative speed is given by

$$n_s - n = n_{slip} \quad (1)$$

$$f_2 = (\text{Poles} \times \text{relative speed}) / 120 \quad (2)$$

$$f_2 = P \times s \times n_s / 120 \quad (3)$$

$$f_2 = s f \quad (4)$$

From the above equation it is clear that the rotor frequency is slip times the stator flux frequency[2].. The change in rotor frequency for various values of slip is given in table 1. Change in slip speed for various values of slip is given in table 2

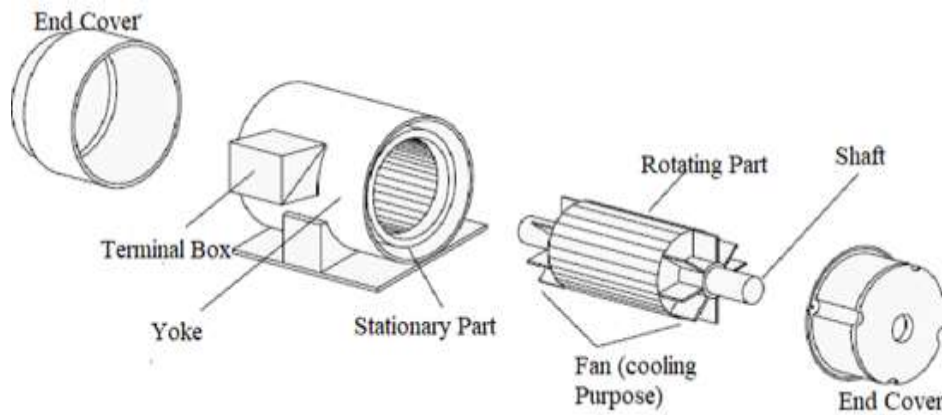

Fig. 1: Three Phase Induction Motor.

Table 1:

S.NO	Slip (s)	Stator flux frequency (f)	Rotor frequency (f ₂)
1	0.1	30	3
2	0.3	35	10.5
3	0.5	40	20
4	0.7	45	31.5
5	0.9	50	45

Table 2:

S.NO	Slip (s)	ns	n	ns-n
1	0.1	900	810	90
2	0.3	1050	735	315
3	0.5	1200	600	600
4	0.7	1350	405	945
5	0.9	1500	150	1350

LOSSES AND EFFICIENCY

In case of small size motors, we can calculate the efficiency using direct load test. This method is not suitable for large size motors [3]. Various types of losses in 3 phase induction motors are fixed losses,

Copper losses and stray losses.

Fixed Losses

These losses mainly consists of core losses, bearing friction loss, brush friction loss (wound rotor motors), windage loss [8]. In general these losses are constant does not vary with load. However, friction losses slightly vary over the working range, these losses can be assumed to be constant[4].

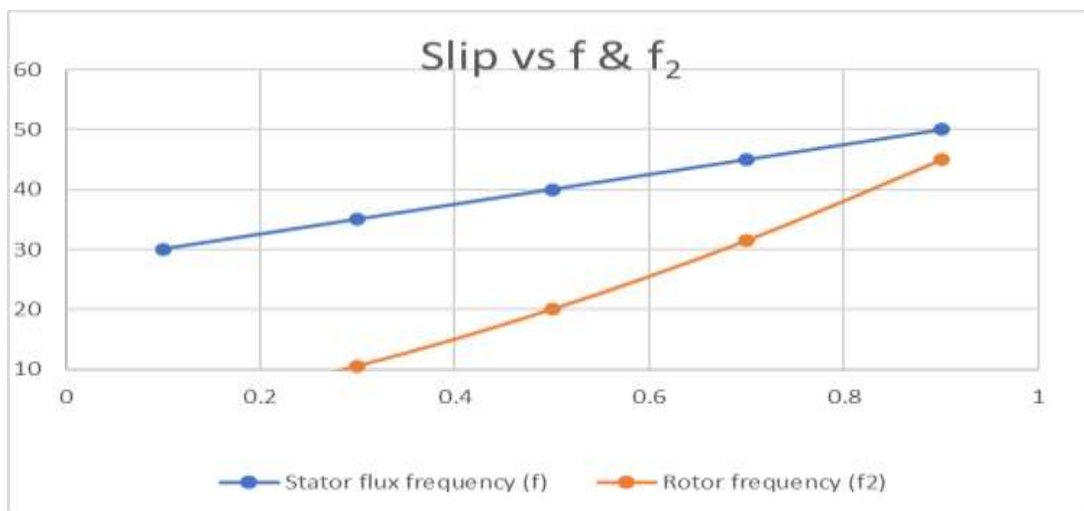

Fig. 2: Slip Versus Frequency

STRAY LOAD LOSSES

Stray losses occur in the core and also in the conductor [9]. These losses cannot be

calculated exactly. Final efficiency can be calculated by reducing 0.5% from the actual efficiency value.

Table 3

S.NO	Output (w)	Mechanical Power Developed(w)	Rotor copper losses(w)
1	50	100	33
2	100	150	49
3	150	200	59
4	200	250	65
5	250	300	81

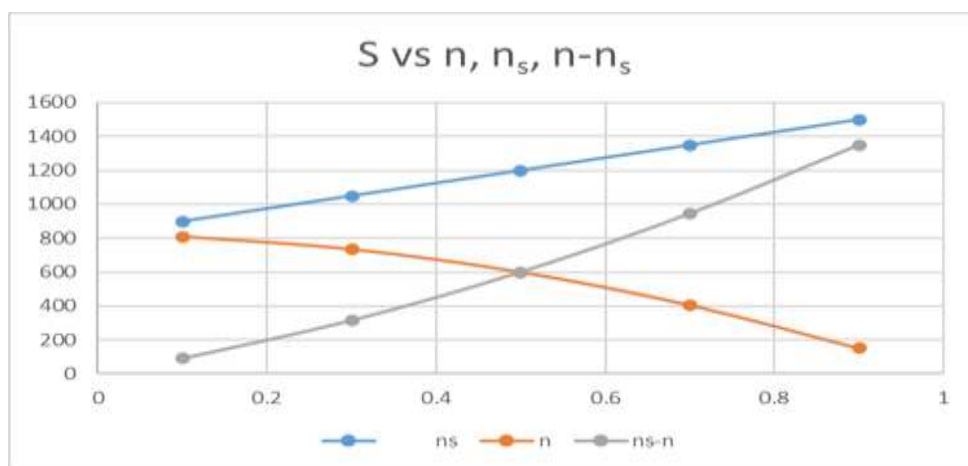

Fig. 3: Slip Versus Speed

COPPER LOSSES

These losses are classified into two types namely stator copper loss and rotor copper loss, brush contact losses (wound rotor). If we know the stator and rotor resistance, copper losses can be easily calculated[5]. Total copper losses can be calculated using blocked rotor test. Rotor copper losses can be calculated by subtracting stator copper losses from the total copper losses. Change in rotor copper losses for various outputs are given in table 3

INFLUENCES OF AIRGAP AND STATOR SLOTS

If the supply voltage is constant, the air gap of the flux remains constant[6]. Change in total power output for different outputs are given in table 4. If we increase the air gap length for the purpose of maintaining air gap flux constant. The magnetizing current should be increased. These increasing in magnetizing current leads to reducing no-load and full load power factor

Table 4:

S.NO	Output (w)	Air gap Power Developed(w)	Total Power Input(w)
1	50	103	153
2	100	155	205
3	150	206	256
4	200	258	308
5	250	309	359

INFLUENCE OF ROTOR RESISTANCE ON STARTING TORQUE

We know that the starting torque of poly

phase motors are directly proportional to the rotor resistance to obtain the high starting torque we can connect the external resistance with the rotor circuit through

slip rings[6].One of the main drawback of connecting resistance value in the rotor circuit is more rotor copper loss and less efficiency. Different rotor slots are shown in figure 5 Figure 5 shows the To avoid this we dis connect the rotor resistance in

case of wound type rotor[7].In squirrel cage type induction motors ,since the rotor conductors are permanently short-circuited can use some special type rotor bars and rotor arrangements to achieve the high starting torque.[10]

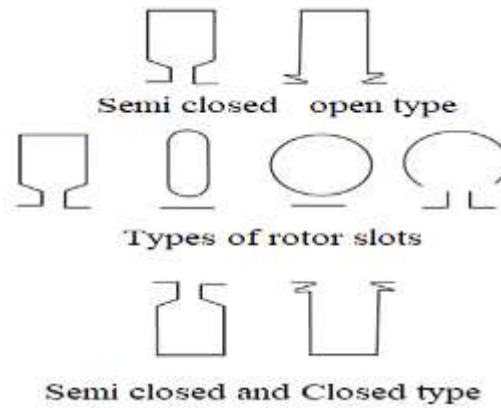

Fig. 4: Rotor Slots.

Torque developed =(Mechanical Power developed)/(Mechanical angular velocity of the rotor)

$$T_d = P_{md} / \omega_r \quad (5)$$

since

$$P_{md} = (1-S) P_g \quad (6)$$

$$\omega_r = (1-S) \omega_s \quad (7)$$

$$T_d = ((1-S)P_g) / ((1-S)\omega_s) = P_g / \omega_s \quad (8)$$

$$P_c / P_m = S / (1-S) \quad (9)$$

$$P_m = ((1-S)P_c) / S \quad (10)$$

$$\text{Stator copper loss } P_{sc} = 3I^2R_1 \quad (11)$$

$$\text{core loss } P_{core} = 3E^2G_c \quad (12)$$

$$\text{Air Gap Power} = P_{ag} = P_{in} - P_{sc} - P_{core} \quad (13)$$

RESULTS

Three phase induction motor is simulated using MATLAB Simulink software .the various results obtained are shown in this section

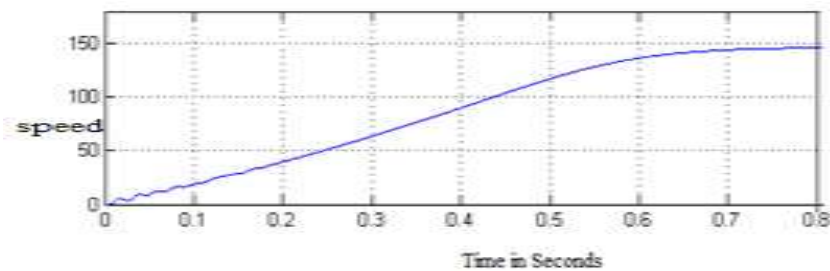

Fig. 5: Variation in Speed.

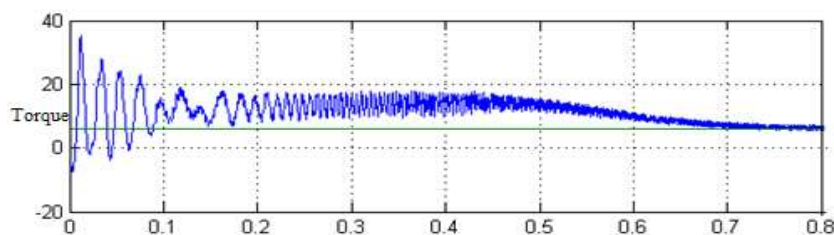

Fig. 6: Variation in Torque.

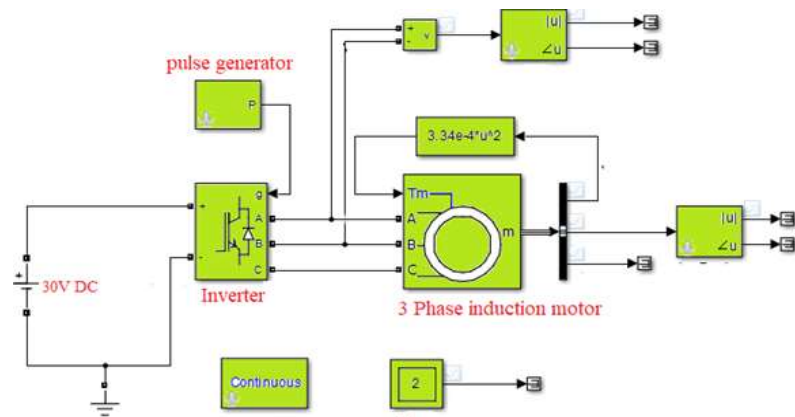

Fig. 7: Matlab Simulink Diagram.

Out put power vs Mech Power Developed & Rotor copper Loss

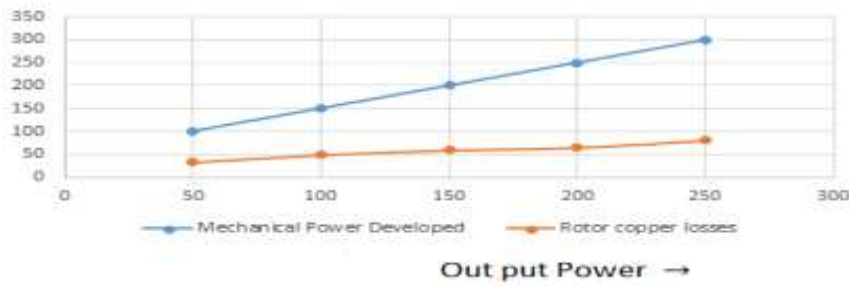

Fig. 8: Copper Losses Versus Output Power.

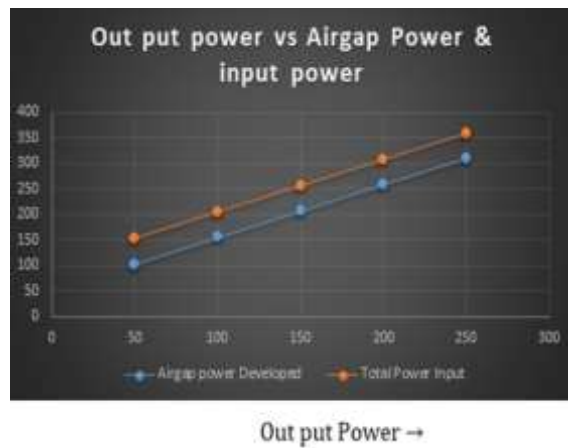

Fig. 7: Variations in Air gap Power & Input Power.

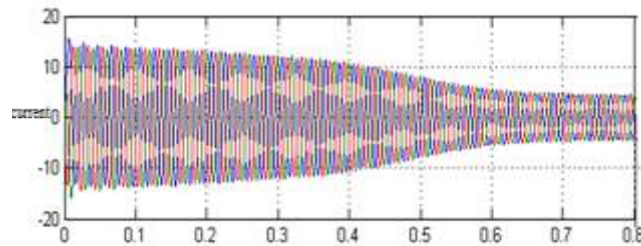

Fig. 10: Output Voltage.

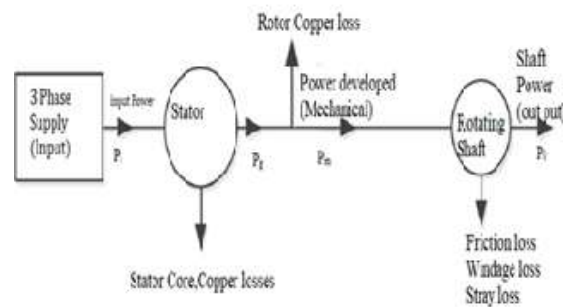

Fig. 11: Power Flow of Induction Motors.

The main loss modules of the induction motor; stator copper losses, rotor copper losses, iron losses, mechanical losses and additional load losses have been presented here as a purpose of the rated power and IE-efficiency classification. IE4 classified motors had the largest share of stator copper loss and rotor copper loss share decreased with increasing effectiveness. The iron loss share increased with the efficiency while the friction and windage and the additional load losses' remained relatively constant. The loss components were determined based on data available in the test reports of the manufacturer. A realistic modern induction motor loss component proportion has been found

CONCLUSION

The main loss components of the induction motors include stator copper losses, rotor copper losses, iron losses, mechanical losses and additional load losses .The above said losses are Explained here as a function of the rated power. Slip value and rotor speeds also included for calculations. The motors having largest share of stator copper loss and rotor copper loss produce less efficiency where the friction and windage and the additional load losses are remains constant. The paper presented MATLAB Simulink results of concerning prototypes of induction motors with die-cast copper rotor cages and premium electrical steel with the aim to verify the actual efficiency improvements

REFERENCES

1. Machines—Part, R. E. (2014). 30-1: Efficiency classes of line operated AC motors (IE code). *IEC Standard*, 60034-30.
2. Machines—Part, R. E. (2014). 30-1: Efficiency classes of line operated AC motors (IE code). *IEC Standard*, 60034-30.
3. Auinger, H. (1999). Determination and designation of the efficiency of electrical machines. *Power Engineering Journal*, 13(1), 15-23.
4. Pyrhonen, J., Jokinen, T., & Hrabovcova, V. (2013). *Design of rotating electrical machines*. John Wiley & Sons.
5. De Almeida, A. T., Ferreira, F. J., Fong, J. A., & Brunner, C. U. (2008, May). Electric motor standards, ecodesign and global market transformation. In *2008 IEEE/IAS Industrial and Commercial Power Systems Technical Conference* (pp. 1-9). IEEE.
6. De Almeida, A. T., Ferreira, F. J., & Fong, J. A. (2010). Standards for efficiency of electric motors. *IEEE Industry Applications Magazine*, 17(1), 12-19.
7. Motors, A. B. B. Generators, "Catalog—Low Voltage Process Performance Motors," Dec. 2017.
8. ABB Motors and Generators, "Test report", *IEC Low voltage motors, multiple documents*, retrieved from ABB Download Center. website:

- '<http://www.abb.com/abblibrary/DownloadCenter/>'
9. International Efficiency Commission. (2007). *Rotating electrical machines—Part 2-1: Standard methods for determining losses and efficiency from tests (excluding machines for traction vehicles)*. IEC 60034-2-1.
 10. Aarniovuori, L., Kolehmainen, J., Kosonen, A., Niemelä, M., & Pyrhönen, J. (2014, September). Uncertainty in motor efficiency measurements. In *2014 International Conference on Electrical Machines (ICEM)* (pp. 323-329). IEEE.