

Keeping LeanSmall solved

Author	Míriam R. García, Karen Bekaert, Winy Messens, Sara Bover-Cid
Report date	Apr 10, 2020 9:13:42 PM

SUMMARY

This model was developed and applied by members of the EFSA Working Group on the transport/storage of fresh fishery products during the preparatory work on the BIOHAZ Scientific Opinion on the use of "tubs" for transporting and storing fresh fishery products (EFSA-Q-2019-00053) (<https://doi.org/10.2903/j.efsa.2020.6091>).

Contents

1. Global Definitions	6
1.1. Parameters.....	6
1.2. Functions.....	9
1.2.1. <i>T outside fridge 1</i>	9
2. Tub	11
2.1. Definitions.....	11
2.1.1. <i>Fish</i>	11
2.1.2. <i>Check outside fish</i>	13
2.1.3. <i>Coordinate Systems</i>	18
2.1.4. <i>Moving Mesh</i>	18
2.2. Geometry 1.....	19
2.2.1. <i>Block TUB (blk1)</i>	19
2.2.2. <i>Block Air (blk5)</i>	20
2.2.3. <i>Block Ice (blk3)</i>	20
2.2.4. <i>Block Fish (blk6)</i>	21
2.2.5. <i>Fish bottom (elp1)</i>	21
2.2.6. <i>Fish middle (elp2)</i>	21
2.3. Materials.....	22
2.3.1. <i>PE (Polyethylene foam)</i>	22
2.3.2. <i>Water, liquid</i>	23
2.3.3. <i>Ice</i>	24
2.3.4. <i>Haddock</i>	25
2.3.5. <i>Air</i>	26
2.4. Heat Transfer in Porous Media.....	27
2.4.1. <i>Interface settings</i>	27
2.4.2. <i>Porous Medium 1</i>	28
2.4.3. <i>Thermal Insulation 1</i>	28
2.4.4. <i>Solid Foam</i>	28
2.4.5. <i>Fluid Air</i>	29
2.4.6. <i>ICE</i>	29
2.4.7. <i>Solid fish</i>	29
2.4.8. <i>Heat Flux 1</i>	29
2.5. Mesh 8.....	30
3. Box	31
3.1. Definitions.....	31
3.1.1. <i>Probes</i>	31
3.1.2. <i>Coordinate Systems</i>	37
3.2. Geometry 2.....	38

3.2.1.	<i>Box (blk1)</i>	38
3.2.2.	<i>IceTop (blk2)</i>	38
3.2.3.	<i>IceBottom (blk3)</i>	39
3.2.4.	<i>Fish/air (blk4)</i>	39
3.2.5.	<i>Fish Corner (elp1)</i>	40
3.2.6.	<i>IceTop 1 (blk5)</i>	40
3.2.7.	<i>Fish middle (elp2)</i>	40
3.3.	Materials.....	41
3.3.1.	<i>Haddock</i>	41
3.3.2.	<i>Air</i>	42
3.3.3.	<i>Ice</i>	43
3.3.4.	<i>Water, liquid</i>	44
3.3.5.	<i>HDPE (skin PE)</i>	44
3.4.	Heat Transfer in Porous Media 2.....	45
3.4.1.	<i>Interface settings</i>	45
3.4.2.	<i>Porous Medium 1</i>	46
3.4.3.	<i>Thermal Insulation 1</i>	46
3.4.4.	<i>Solid Foam</i>	47
3.4.5.	<i>ICE</i>	47
3.4.6.	<i>Solid fish</i>	47
3.4.7.	<i>Heat Flux 1</i>	47
3.5.	Mesh 9.....	48
4.	Study 3	49
4.1.	Time Dependent.....	49
5.	Results	50
5.1.	Data Sets.....	50
5.1.1.	<i>Study 3/Solution 3 (1)</i>	50
5.1.2.	<i>Study 3/Solution 3 (2)</i>	50
5.1.3.	<i>Probe Solution 3</i>	51
5.1.4.	<i>TUB-max surface middle fish</i>	51
5.1.5.	<i>TUB-max surface corner fish</i>	52
5.1.6.	<i>TUB-Max</i>	52
5.1.7.	<i>TUB-Min</i>	52
5.1.8.	<i>Probe Solution 4</i>	53
5.1.9.	<i>BFoam Average</i>	53
5.1.10.	<i>Blce Average</i>	54
5.1.11.	<i>% top ice average</i>	54
5.1.12.	<i>% bottom ice average 1</i>	55
5.1.13.	<i>Air Average</i>	55
5.1.14.	<i>Ice Averte temp</i>	55

5.1.15.	<i>%ice</i>	56
5.1.16.	<i>Water Average</i>	56
5.1.17.	<i>Water Maximum</i>	56
5.1.18.	<i>Foam average</i>	57
5.1.19.	<i>Foam maximum boundary</i>	57
5.1.20.	<i>BFoam Maximum</i>	57
5.1.21.	<i>BOX- max surface middle fish</i>	58
5.1.22.	<i>BOX- max surface corner</i>	58
5.1.23.	<i>BOX-max</i>	58
5.1.24.	<i>Probe Solution 5</i>	59
5.1.25.	<i>BOX-min</i>	59
5.1.26.	<i>Ice temp</i>	60
5.2.	<i>Derived Values</i>	60
5.2.1.	<i>TUB-max surface middle fish</i>	60
5.2.2.	<i>TUB-max surface corner fish</i>	60
5.2.3.	<i>TUB-Max</i>	61
5.2.4.	<i>TUB-Min</i>	61
5.2.5.	<i>%ice</i>	61
5.2.6.	<i>Outside Temp</i>	62
5.2.7.	<i>BOX- max surface middle fish</i>	62
5.2.8.	<i>BOX- max surface corner</i>	62
5.2.9.	<i>BOX-max</i>	63
5.2.10.	<i>BOX-min</i>	63
5.2.11.	<i>% top ice average</i>	63
5.2.12.	<i>% bottom ice average 1</i>	63
5.2.13.	<i>Air Average</i>	64
5.2.14.	<i>Ice Aerate temp</i>	64
5.2.15.	<i>Water Average</i>	64
5.2.16.	<i>Water Maximum</i>	65
5.2.17.	<i>Foam average</i>	65
5.2.18.	<i>Foam maximum boundary</i>	65
5.2.19.	<i>BFoam Average</i>	66
5.2.20.	<i>Blce Average</i>	66
5.2.21.	<i>BFoam Maximum</i>	66
5.2.22.	<i>Ice temp</i>	66
5.3.	<i>Plot Groups</i>	67
5.3.1.	<i>TUB fish</i>	67
5.3.2.	<i>BOX fish</i>	67
5.3.3.	<i>TUB Several</i>	68
5.3.4.	<i>BOX several</i>	68

5.3.5. Comparison TUB-BOX.....69

1 Global Definitions

Date	Apr 10, 2020 8:34:39 AM
------	-------------------------

GLOBAL SETTINGS

Name	Keeping LeanSmall solved.mph
Version	COMSOL Multiphysics 5.4 (Build: 388)

USED PRODUCTS

COMSOL Multiphysics
Heat Transfer Module

1.1 PARAMETERS

GENERAL

Name	Expression	Value	Description
Tfish_0	0 [degC]	273.15 K	Initial temperature fish
W_ice	38 [kg]	38 kg	Tubs-Ice weight
BW_ice	15 [kg]	15 kg	Box-Ice weight
TFoam_0	1.5 [degC]	274.65 K	Initial temperature foam
Twater_0	2.7 [degC]	275.85 K	Initial Water temperature (due to approximation)
fish_w	(29/2) [cm]	0.145 m	Width fish radius
fish_d	(15.5/2) [cm]	0.0775 m	Depth fish radius
fish_h	(0.85/2) [cm]	0.00425 m	Height fish radius
rho_fish	1054 [kg/m^3]	1054 kg/m ³	Fish density
dT	1 [K]	1 K	Transition Interval
T_trans	0 [degC]	273.15 K	Transition temperature
lm	333.5 [kJ/kg]	3.335E5 J/kg	Latent heat of fusion
hh	5 [W/(m^2*K)]	5 W/(m ² *K)	Heat transfer coefficient
BTfishsmall_0	Tfish_0	273.15 K	Box- Initial Temp manipulated fish
TTfishsmall_0	Tfish_0	273.15 K	Tub-Initial Temp manipulated fish
Tice_0	-0.5 [degC]	272.65 K	Initial ice

Name	Expression	Value	Description
			temperature (due to approximation)
Tair_0	2.7 [degC]	275.85 K	Initial temperature air inside box/tub
Bcontent_w	37 [cm]	0.37 m	Box-Content width
Bcontent_d	62 [cm]	0.62 m	Box-Content depth
Bthickness	5 [mm]	0.005 m	Box-material thickness
Bcontent_h	BBlock_h + Bice_h	0.22464 m	Box-Content height should be < 0.23
BW_fish	30 [kg]	30 kg	Box-Fish weight
TubThickness	3.6 [cm]	0.036 m	Tub-Thickness
content_w	93 [cm]	0.93 m	Tub-Content width
content_d	113 [cm]	1.13 m	Tub-Content depth
content_h	61 [cm]	0.61 m	Tub-Content height
W_fish	440 [kg]	440 kg	Tub-Tubs-Fish Weight
V_water	100 [L]	0.1 m ³	Tub-Water liters
theta	$(VT_{fish_wish} - V_{smallfish}) / (VT_{fish_wish} - V_{smallfish} + V_{water_wish})$	0.8066	Volume fraction
box_w	$Bcontent_w + 2*Bthickness$	0.38 m	Box-width (should be < 0.45)
box_d	$Bcontent_d + 2*Bthickness$	0.63 m	Box-depth (should be < 0.8)
box_h	$BBlock_h + Bthickness + Bice_h$	0.22964 m	Box-height (should be < 0.27)
Bdw	Bthickness	0.005 m	Box-Foam thickness width
Bdd	Bthickness	0.005 m	Box-Foam thickness depth
Bdh	Bthickness	0.005 m	Box-Foam thickness height on bottom
BBlock_w	Bcontent_w	0.37 m	Box-Width of block with air and fish

Name	Expression	Value	Description
BBlock_d	Bcontent_d	0.62 m	Box-Depth of block with air and fish
BBlock_h	$(BV_{\text{smallfish}} + (BVT_{\text{fish_wish}} - BV_{\text{smallfish}})/\theta_B)/(BBlock_w * BBlock_d)$	0.15341 m	Box-Height of block with fish and air
BVblock	$(BBlock_w * BBlock_d * BBlock_h)$	0.035192 m ³	Box-Total volume of the block with air and fish
Bice_h	$BV_{\text{ice_Wish}}/(Bcontent_w * Bcontent_d)$	0.071229 m	Box-Ice thickness
BVTfish	$BV_{\text{block}} * \theta_B + BV_{\text{smallfish}}$	0.028786 m ³	Box-Volume block with air and fish
BVTfish_wish	$(BW_{\text{fish}}/\rho_{\text{fish}})$	0.028463 m ³	Box-Wish Volume fish total
BVice	$Bice_h * Bcontent_d * Bcontent_w$	0.01634 m ³	Box-Model ice volume
BVice_Wish	$(BW_{\text{ice}}/918[\text{kg/m}^3])$	0.01634 m ³	Box-Wish Volume ice
TporousBOX_0	$T_{\text{fish}_0} * \theta_B + T_{\text{air}_0} * (1 - \theta_B)$	273.67 K	Box-Initial temperature for block of air and fish
theta_B	theta	0.8066	Box-Effective volume air/fish
BVsmallfish	$2 * (4/3) * \pi * (\text{fish}_h * \text{fish}_d * \text{fish}_w)$	4.0011E-4 m ³	Box-Small fish volume
tub_w	$\text{content}_w + 2 * dw$	1.002 m	Tub-width
tub_d	$\text{content}_d + 2 * dd$	1.202 m	Tub-depth
tub_h	$\text{content}_h + 2 * dh$	0.682 m	Tub-height
dw	TubThickness	0.036 m	Tub-Foam thickness width
dd	TubThickness	0.036 m	Tub-Foam thickness depth
dh	TubThickness	0.036 m	Tub-Foam thickness height
Block_w	content_w	0.93 m	Tub-Block fish/water width
Block_d	content_d	1.13 m	Tub-Block fish/water depth
Block_h	$(VT_{\text{fish_wish}} + V_{\text{water_wish}})/((\text{content}_w) * (\text{content}_d))$	0.49239 m	Tub-Block fish/water height

Name	Expression	Value	Description
Vair	$(\text{content_w} * \text{content_d} * (\text{content_h} - \text{ice_h} - \text{Block_h}))$	0.082197 m ³	Tub-Air volume
air_h	$(\text{Vair}) / (\text{content_d} * \text{content_w})$	0.078216 m	Tub-Air layer height
VTfish	$\text{Vblock} * \text{theta} + \text{Vsmallfish}$	0.41778 m ³	Tub-Model Volume total fish
VTfish_wish	$(\text{W_fish} / \text{rho_fish})$	0.41746 m ³	Tub-Wish Volume fish total
Vice	$\text{ice_h} * \text{content_d} * \text{content_w}$	0.041394 m ³	Tub-Model Volume ice
Vice_Wish	$(\text{W_ice} / 918 [\text{kg}/\text{m}^3])$	0.041394 m ³	Tub-Wish Volume ice
Vwater	$\text{Vblock} * (1 - \text{theta})$	0.10008 m ³	Tub-Model volume water
Vwater_wish	V_water	0.1 m ³	Tub-Wish Volume water
ice_h	$\text{Vice_Wish} / (\text{content_w} * \text{content_d})$	0.039389 m	Tub-Ice thickness
TporousTUB_0	$\text{Tfish}_0 * \text{theta} + \text{Twater}_0 * (1 - \text{theta})$	273.67 K	Tub-Initial temperature for block of water/fish
Vsmallfish	$2 * (4/3) * \pi * (\text{fish_h} * \text{fish_d} * \text{fish_w})$	4.0011E-4 m ³	Tub-Small fish volume
Vblock	$\text{Block_w} * \text{Block_d} * \text{Block_h}$	0.51746 m ³	Tub-Block water/fish volume

1.2 FUNCTIONS

1.2.1 T outside fridge 1

Function names	Tout
Function type	Interpolation

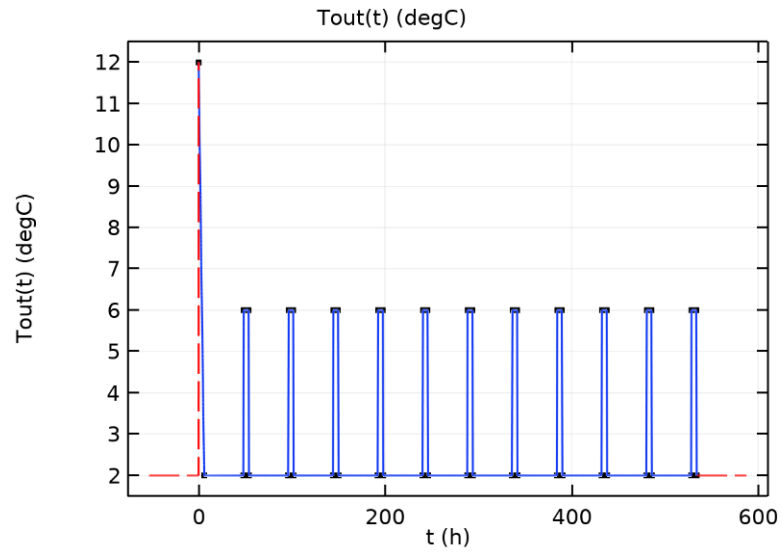

T outside fridge ¹

¹ Simulations are run for 5 days (5*24 hours), but input variables are defined for larger times to avoid problems if final time is changed.

2 Tub

2.1 DEFINITIONS

2.1.1 Fish

2.1.1.1 Probes

2.1.1.1.1 TUB-max surface middle fish

Probe type	Boundary probe
------------	----------------

SELECTION

Geometric entity level	Boundary
Selection	Boundaries 27–34

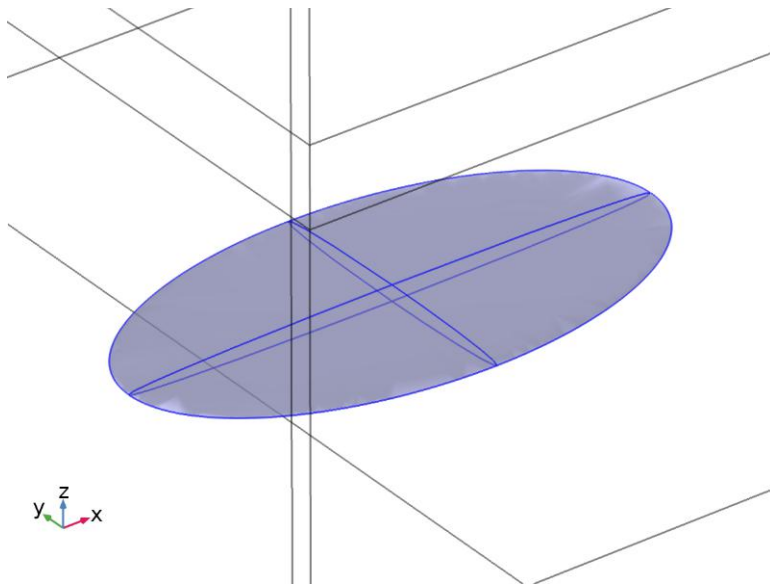

Selection

2.1.1.1.2 TUB-max surface corner fish

Probe type	Boundary probe
------------	----------------

SELECTION

Geometric entity level	Boundary
Selection	Boundaries 19–25

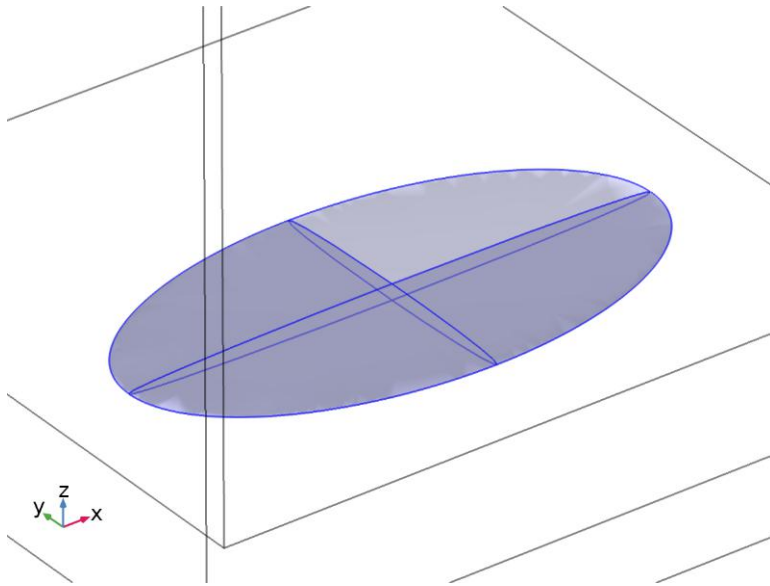

Selection

2.1.1.1.3 TUB-Max

Probe type	Domain probe
------------	--------------

SELECTION

Geometric entity level	Domain
Selection	Domains 2, 5-6

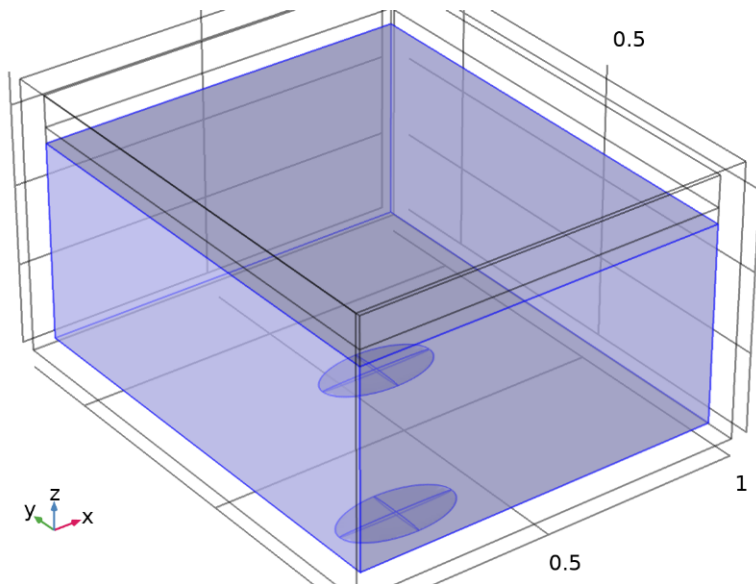

Selection

2.1.1.1.4 TUB-Min

Probe type	Domain probe
------------	--------------

SELECTION

Geometric entity level	Domain
Selection	Domains 2, 5-6

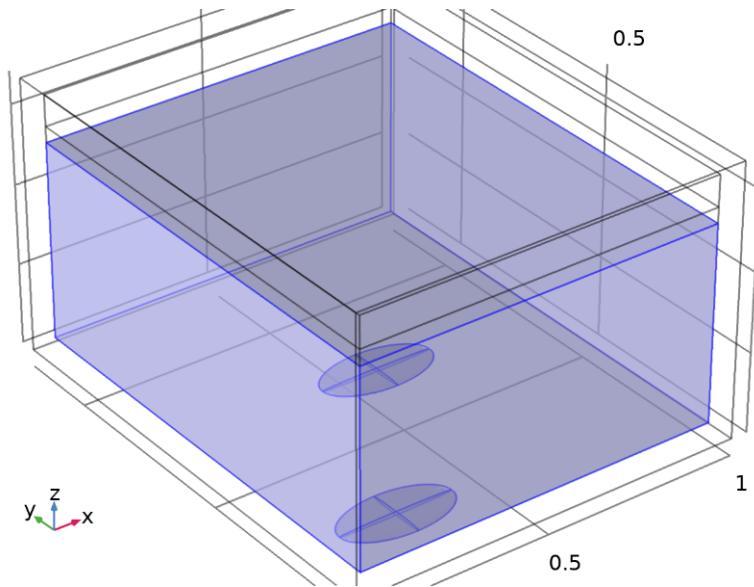

Selection

2.1.2 Check outside fish

2.1.2.1 %ice

Probe type	Domain probe
------------	--------------

SELECTION

Geometric entity level	Domain
Selection	Domain 3

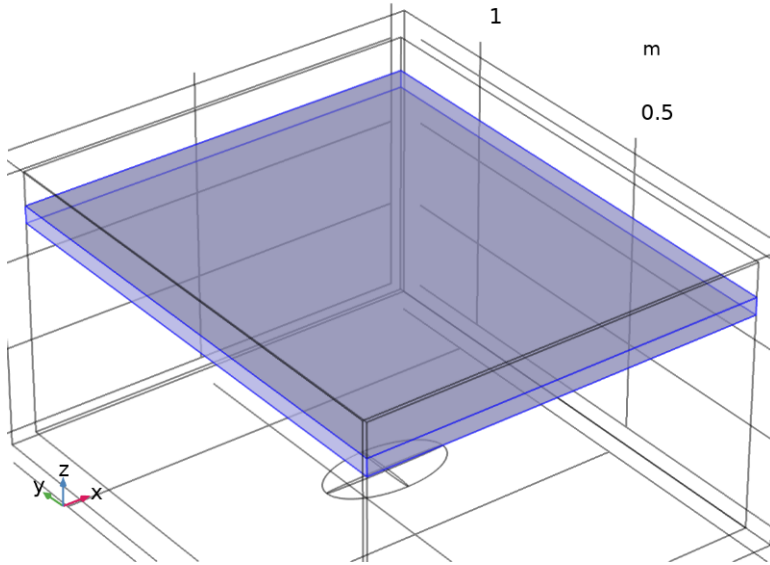

Selection

2.1.2.2 Outside Temp

Probe type Global variable probe

2.1.2.3 Air Average

Probe type Domain probe

SELECTION

Geometric entity level	Domain
Selection	Domain 4

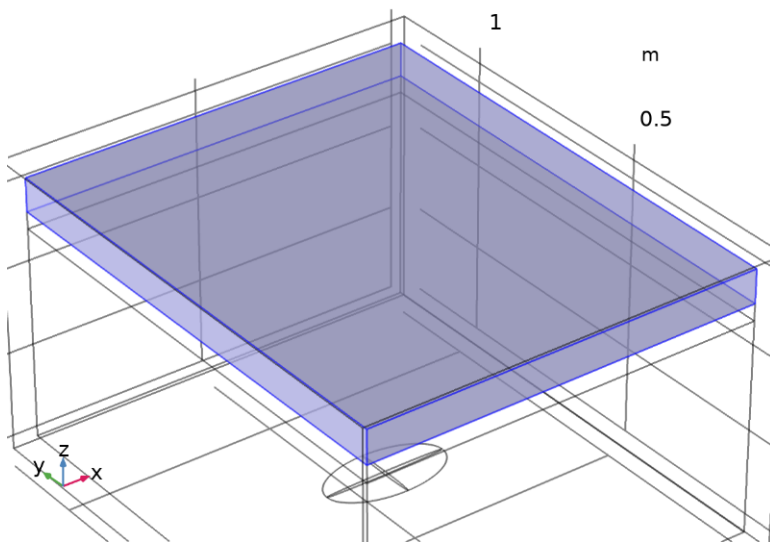

Selection

2.1.2.4 Ice Average temp

Probe type	Domain probe
------------	--------------

SELECTION

Geometric entity level	Domain
Selection	Domain 3

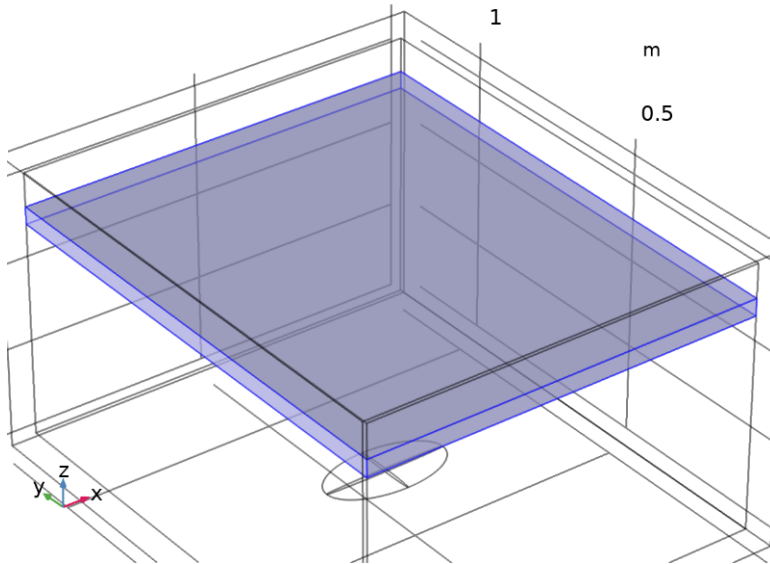

Selection

2.1.2.5 Water Average

Probe type	Domain probe
------------	--------------

SELECTION

Geometric entity level	Domain
Selection	Domain 2

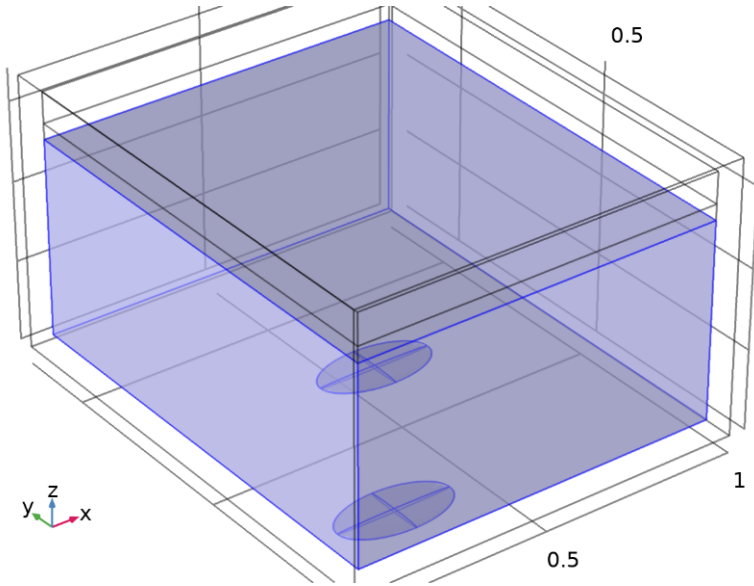

Selection

2.1.2.6 Water Maximum

Probe type Domain probe

SELECTION

Geometric entity level	Domain
Selection	Domain 2

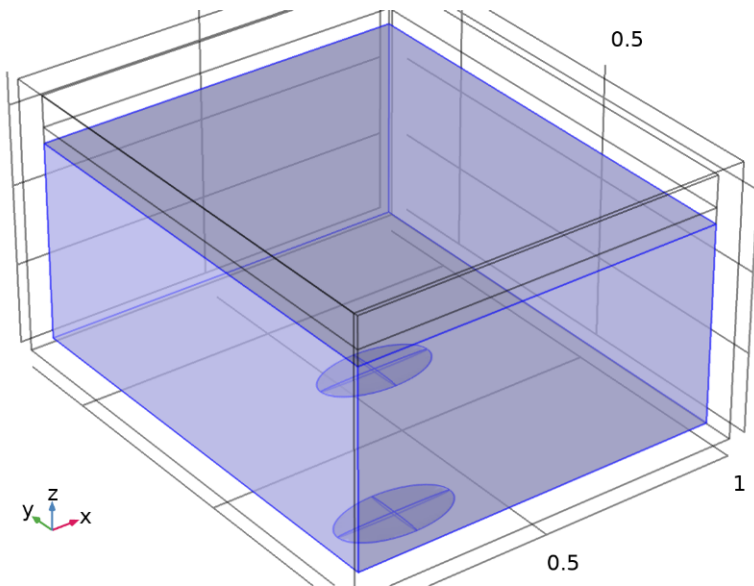

Selection

2.1.2.7 Foam average

Probe type Domain probe

SELECTION

Geometric entity level	Domain
Selection	Domain 1

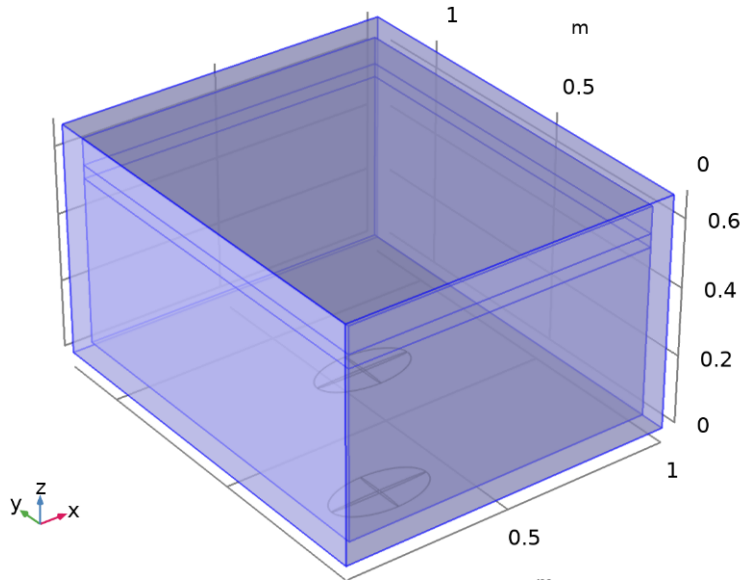

Selection

2.1.2.8 Foam maximum boundary

Probe type	Boundary probe
------------	----------------

SELECTION

Geometric entity level	Boundary
Selection	Boundaries 1-5, 38

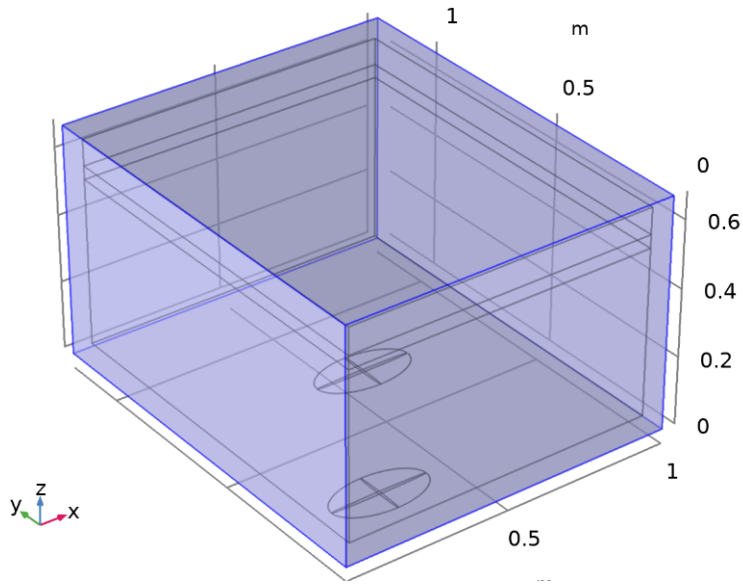

Selection

2.1.3 Coordinate Systems

2.1.3.1 Boundary System 1

Coordinate system type	Boundary system
Tag	sys1

COORDINATE NAMES

First	Second	Third
t1	t2	n

2.1.4 Moving Mesh

2.1.4.1 Rotating Domain 1

Tag	rot1
-----	------

SELECTION

Geometric entity level	Domain
Selection	Domains 1–6

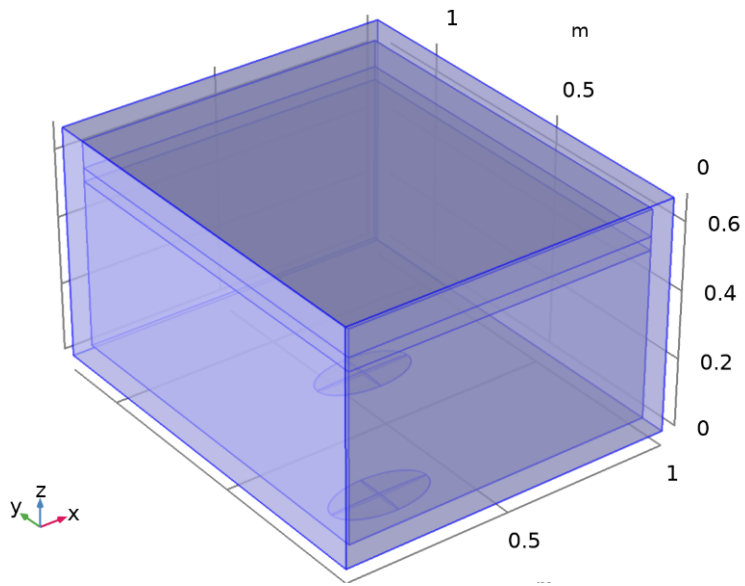

Selection

2.2 GEOMETRY 1

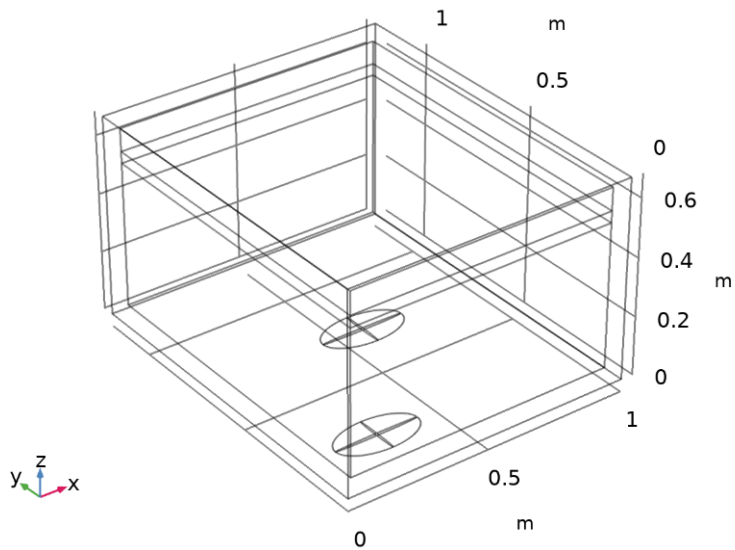

Geometry 1

UNITS

Length unit	m
Angular unit	deg

2.2.1 Block TUB (blk1)

POSITION

Description	Value
-------------	-------

Description	Value
Position	{0, 0, 0}

AXIS

Description	Value
Axis type	z - axis

SIZE AND SHAPE

Description	Value
Width	tub_w
Depth	tub_d
Height	tub_h

2.2.2 Block Air (blk5)

POSITION

Description	Value
Position	{dw, dd, dh + Block_h + ice_h}

AXIS

Description	Value
Axis type	z - axis

SIZE AND SHAPE

Description	Value
Width	content_w
Depth	content_d
Height	air_h

2.2.3 Block Ice (blk3)

POSITION

Description	Value
Position	{dw, dd, dh + Block_h}

AXIS

Description	Value
Axis type	z - axis

SIZE AND SHAPE

Description	Value
-------------	-------

Description	Value
Width	content_w
Depth	content_d
Height	ice_h

2.2.4 Block Fish (blk6)

POSITION

Description	Value
Position	{dw, dd, dh}

AXIS

Description	Value
Axis type	z - axis

SIZE AND SHAPE

Description	Value
Width	Block_w
Depth	Block_d
Height	Block_h

2.2.5 Fish bottom (elp1)

POSITION

Description	Value
Position	{dw + fish_w + 0.02, dd + fish_d + 0.02, dh + fish_h + 0.02}

AXIS

Description	Value
Axis type	z - axis

SIZE

Description	Value
a-semiaxis	fish_w
b-semiaxis	fish_d
c-semiaxis	fish_h

2.2.6 Fish middle (elp2)

POSITION

Description	Value
-------------	-------

Description	Value
Position	{dw + Block_w/2, dd + Block_d/2, dh + fish_h + 0.02}

AXIS

Description	Value
Axis type	z - axis

SIZE

Description	Value
a-semiaxis	fish_w
b-semiaxis	fish_d
c-semiaxis	fish_h

2.3 MATERIALS

2.3.1 PE (Polyethylene foam)

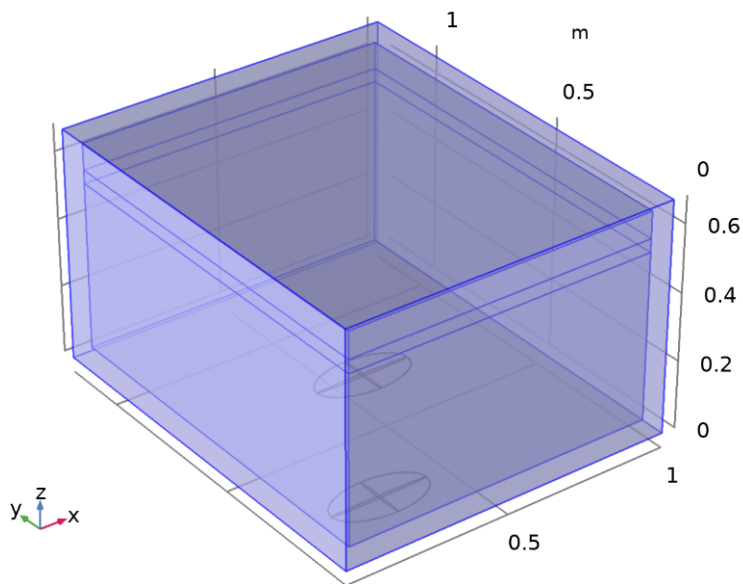

PE (Polyethylene foam)

SELECTION

Geometric entity level	Domain
Selection	Domain 1

MATERIAL PARAMETERS

Name	Value	Unit
Thermal conductivity	0.05	W/(m·K)
Density	70	kg/m ³

Name	Value	Unit
Heat capacity at constant pressure	2.3*1000	J/(kg·K)

2.3.2 Water, liquid

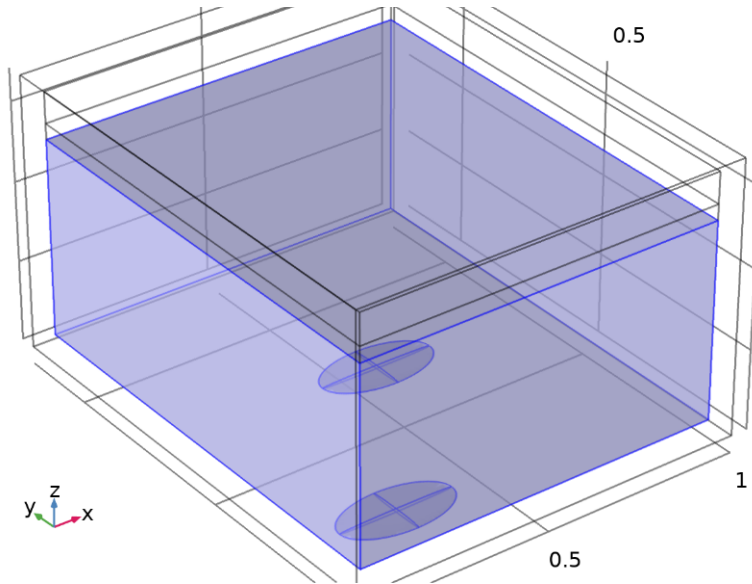

Water, liquid

SELECTION

Geometric entity level	Domain
Selection	Domain 2

MATERIAL PARAMETERS

Name	Value	Unit
Ratio of specific heats	gamma_w(T)	1
Heat capacity at constant pressure	Cp(T)	J/(kg·K)
Density	rho(T)	kg/m ³
Thermal conductivity	k(T)	W/(m·K)

2.3.3 Ice

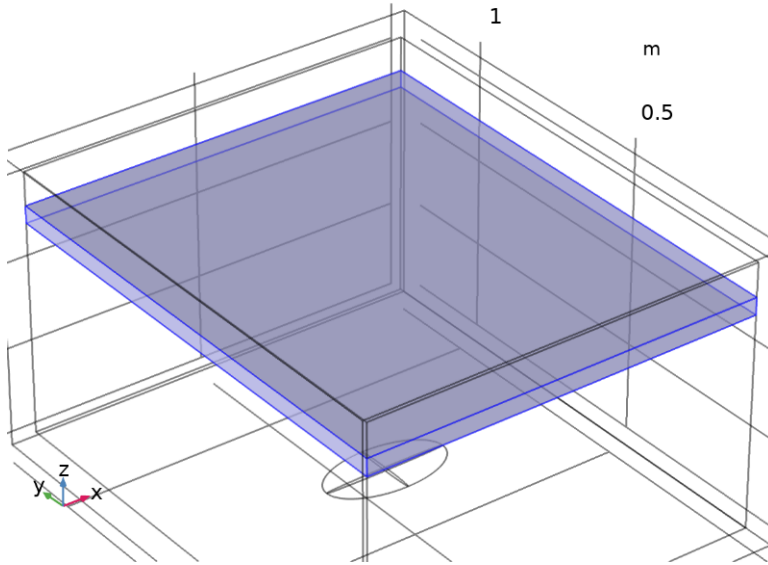

Ice

SELECTION

Geometric entity level	Domain
Selection	Domain 3

MATERIAL PARAMETERS

Name	Value	Unit
Thermal conductivity	2.31	W/(m·K)
Density	918	kg/m ³
Heat capacity at constant pressure	2052	J/(kg·K)

2.3.4 Haddock

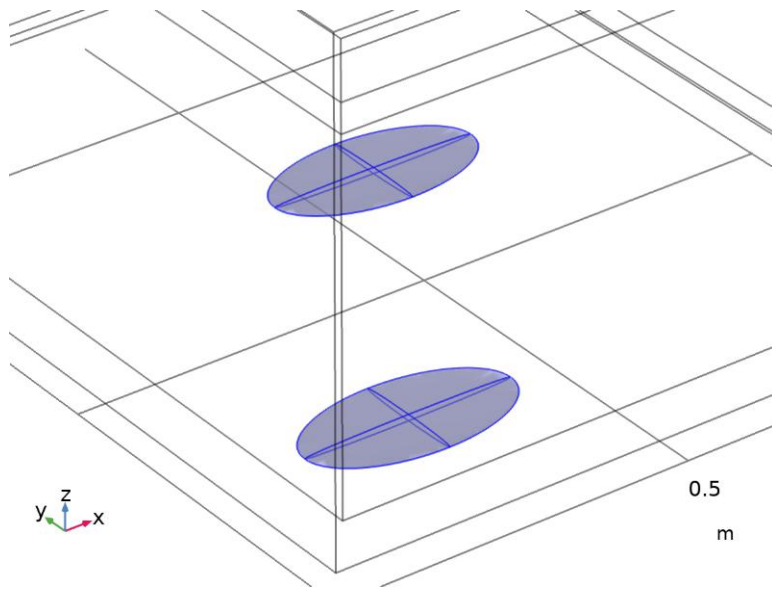

Haddock

SELECTION

Geometric entity level	Domain
Selection	Domains 5-6

MATERIAL PARAMETERS

Name	Value	Unit
Density	1054	kg/m ³
Heat capacity at constant pressure	3.73	J/(kg·K)
Thermal conductivity	0.43	W/(m·K)

2.3.5 Air

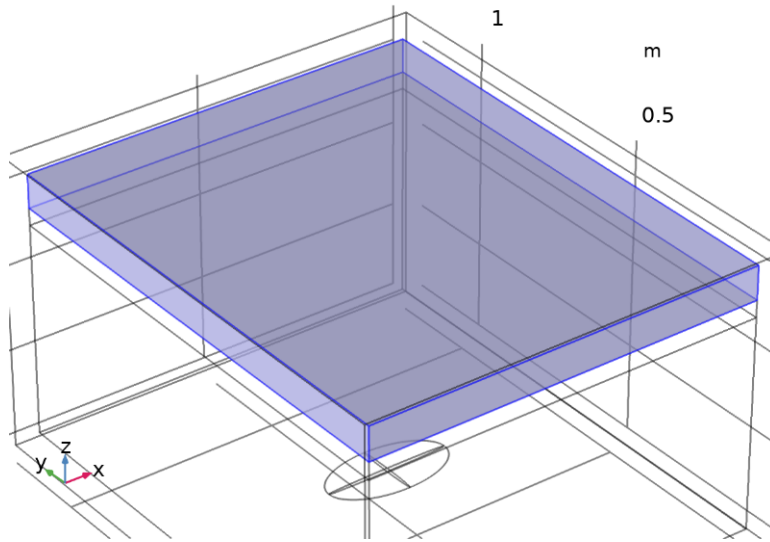

Air

SELECTION

Geometric entity level	Domain
Selection	Domain 4

MATERIAL PARAMETERS

Name	Value	Unit
Ratio of specific heats	1.4	1
Heat capacity at constant pressure	$C_p(T)$	J/(kg·K)
Density	$\rho(p_A, T)$	kg/m ³
Thermal conductivity	$k(T)$	W/(m·K)

2.4 HEAT TRANSFER IN POROUS MEDIA

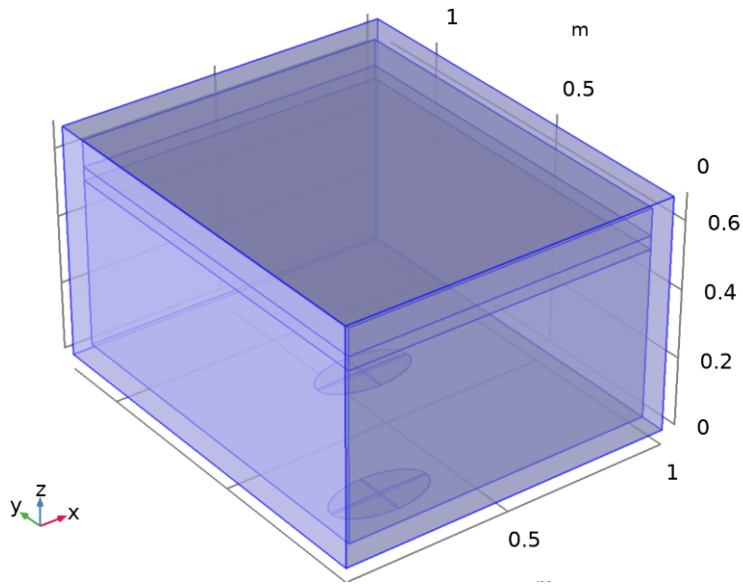

Heat Transfer in Porous Media

SELECTION

Geometric entity level	Domain
Selection	Domains 1–6

EQUATIONS

$$(\rho c_p)_{\text{eff}} \frac{\partial T}{\partial t} + \rho c_p \mathbf{u} \cdot \nabla T + \nabla \cdot \mathbf{q} = Q + Q_{\text{vd}}$$

$$\mathbf{q} = -k_{\text{eff}} \nabla T$$

2.4.1 Interface settings

2.4.1.1 Discretization

SETTINGS

Description	Value
Temperature	Linear

2.4.1.2 Physical model

SETTINGS

Description	Value
Heat transfer in biological tissue	Off
Isothermal domain	Off
Heat transfer in porous media	On
Porous matrix model	Standard

Description	Value
Heat transfer in alloys	Off
Reference temperature	User defined
Reference temperature	3 [degC]

FEATURES

Porous Medium 1
Initial Values 1
Thermal Insulation 1
Solid Foam
Initial Foam
Fluid Air
Initial Air
ICE
Initial Values ICE
Solid fish
Initial Fish
Initial Fish bottom
Initial Fish middle
Heat Flux 1

2.4.2 Porous Medium 1

EQUATIONS

$$(\rho c_p)_{\text{eff}} \frac{\partial T}{\partial t} + \rho c_p \mathbf{u} \cdot \nabla T + \nabla \cdot \mathbf{q} = Q + Q_p + Q_{\text{vd}}$$

$$\mathbf{q} = -k_{\text{eff}} \nabla T$$

$$(\rho c_p)_{\text{eff}} = \theta_p \rho_p c_{p,p} + (1 - \theta_p) \rho c_p$$

$$k_{\text{eff}} = \theta_p k_p + (1 - \theta_p) k + k_{\text{disp}}$$

2.4.3 Thermal Insulation 1

EQUATIONS

$$-\mathbf{n} \cdot \mathbf{q} = 0$$

2.4.4 Solid Foam

EQUATIONS

$$\rho c_p \frac{\partial T}{\partial t} + \rho c_p \mathbf{u} \cdot \nabla T + \nabla \cdot \mathbf{q} = Q + Q_{\text{ted}}$$

$$\mathbf{q} = -k \nabla T$$

2.4.5 Fluid Air

EQUATIONS

$$\rho c_p \frac{\partial T}{\partial t} + \rho c_p \mathbf{u} \cdot \nabla T + \nabla \cdot \mathbf{q} = Q + Q_p + Q_{\text{vd}}$$

$$\mathbf{q} = -k \nabla T$$

2.4.6 ICE

EQUATIONS

$$\rho c_p \frac{\partial T}{\partial t} + \rho c_p \mathbf{u} \cdot \nabla T + \nabla \cdot \mathbf{q} = Q + Q_{\text{ted}}$$

$$\mathbf{q} = -k \nabla T$$

2.4.6.1 Phase Change Material 1

EQUATIONS

$$\rho = \rho_{\text{solid}}$$

$$c_p = \theta_1 c_{p1} + \theta_2 c_{p2} + L_{1 \rightarrow 2} \frac{\partial \alpha_m}{\partial T}$$

$$\alpha_m = \frac{1}{2} \frac{\theta_2 - \theta_1}{\theta_1 + \theta_2}$$

$$k = \theta_1 k_1 + \theta_2 k_2$$

$$\theta_1 + \theta_2 = 1$$

2.4.7 Solid fish

EQUATIONS

$$\rho c_p \frac{\partial T}{\partial t} + \rho c_p \mathbf{u} \cdot \nabla T + \nabla \cdot \mathbf{q} = Q + Q_{\text{ted}}$$

$$\mathbf{q} = -k \nabla T$$

2.4.8 Heat Flux 1

EQUATIONS

$$-\mathbf{n} \cdot \mathbf{q} = q_0$$

$$q_0 = h(T_{\text{ext}} - T)$$

2.5 MESH 8

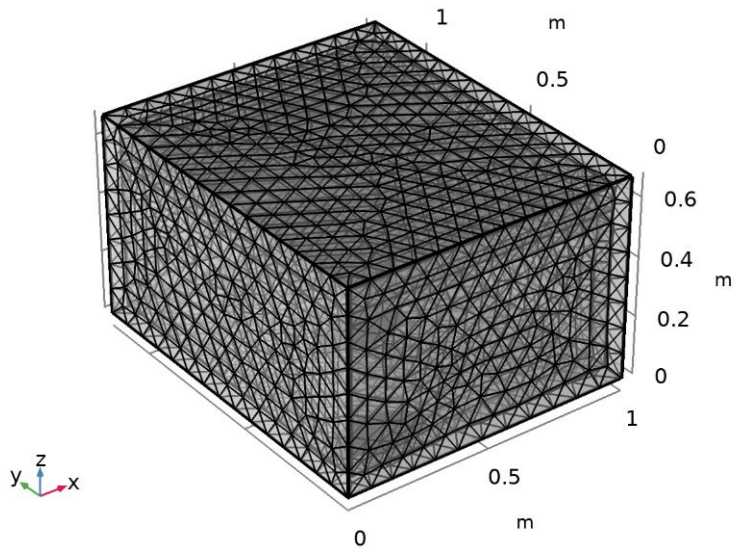

Mesh 8

3 Box

3.1 DEFINITIONS

3.1.1 Probes

3.1.1.1 BOX- max surface middle fish

Probe type	Boundary probe
------------	----------------

SELECTION

Geometric entity level	Boundary
Selection	Boundaries 23–26, 31–34

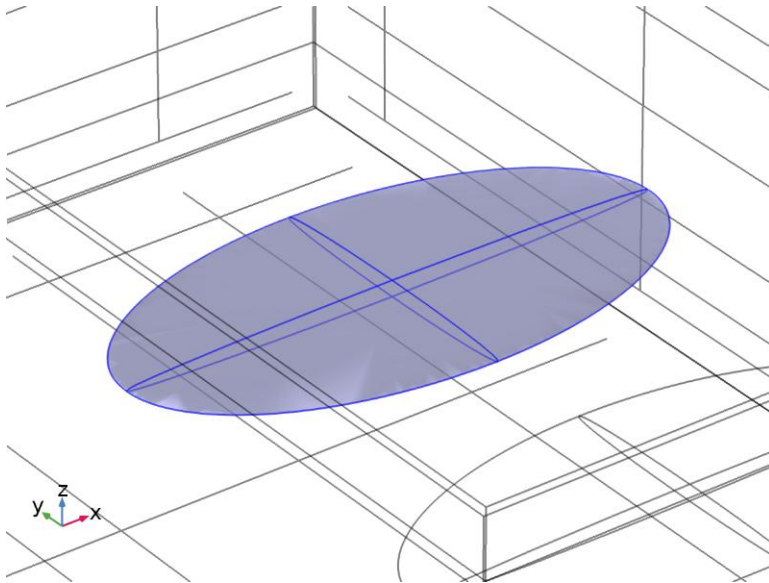

Selection

3.1.1.2 BOX- max surface corner

Probe type	Boundary probe
------------	----------------

SELECTION

Geometric entity level	Boundary
Selection	Boundaries 19–22, 27–30

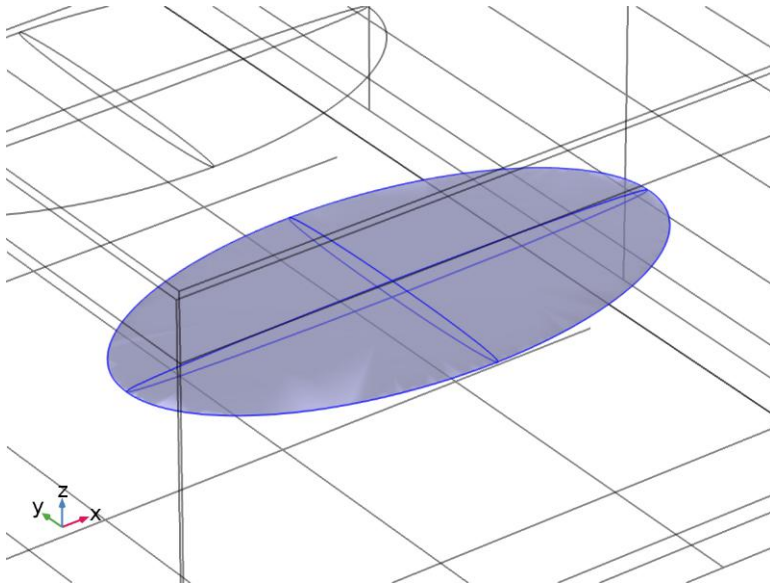

Selection

3.1.1.3 BOX-max

Probe type	Domain probe
------------	--------------

SELECTION

Geometric entity level	Domain
Selection	Domains 3, 5-6

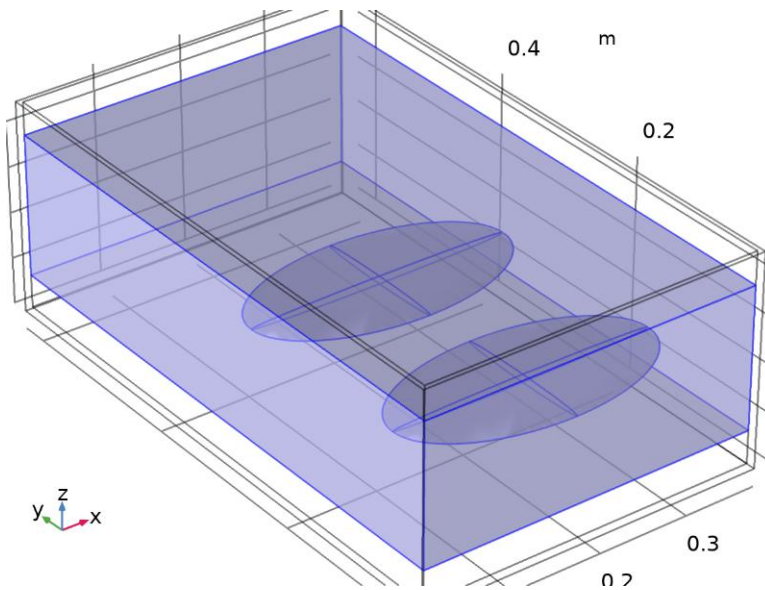

Selection

3.1.1.4 BOX-min

Probe type	Domain probe
------------	--------------

SELECTION

Geometric entity level	Domain
Selection	Domains 3, 5-6

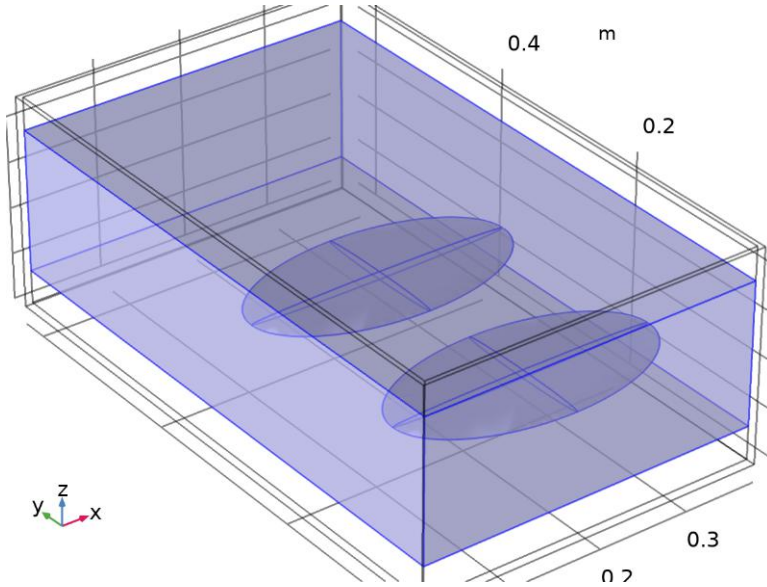

Selection

3.1.1.5 % top ice average

Probe type	Domain probe
------------	--------------

SELECTION

Geometric entity level	Domain
Selection	Domain 4

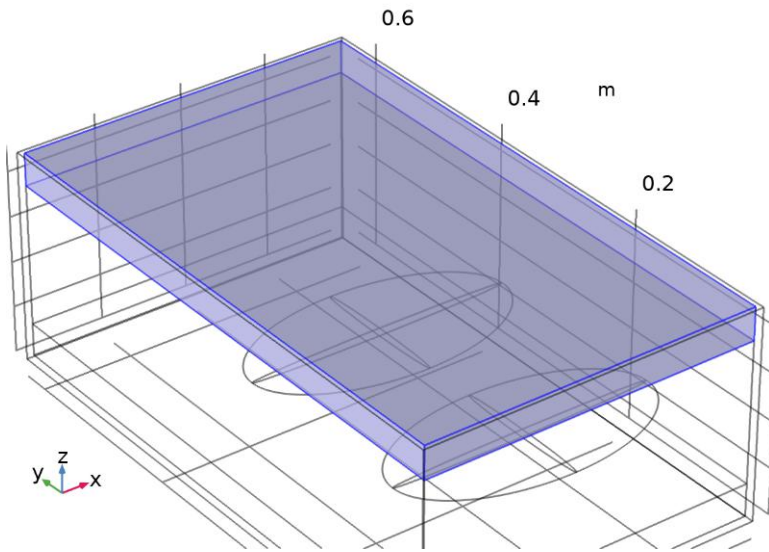

Selection

3.1.1.6 % bottom ice average 1

Probe type Domain probe

SELECTION

Geometric entity level	Domain
Selection	Domain 2

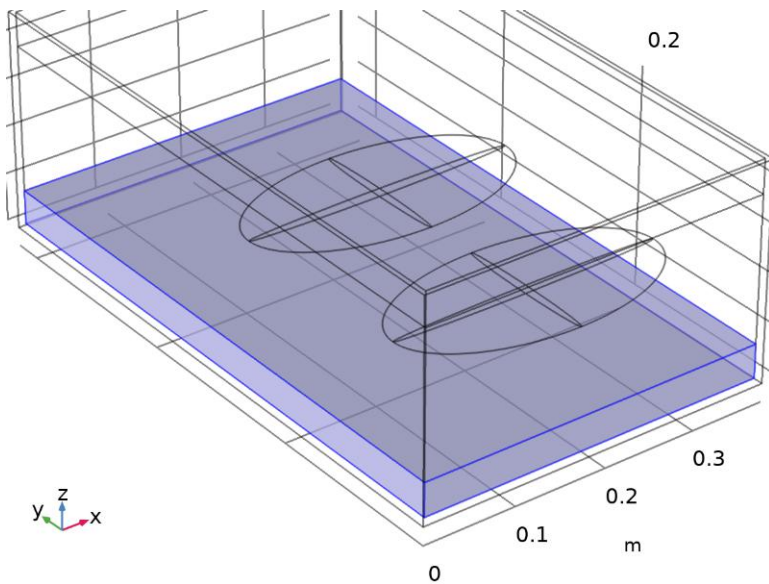

Selection

3.1.1.7 BFoam Average

Probe type Domain probe

SELECTION

Geometric entity level	Domain
Selection	Domain 1

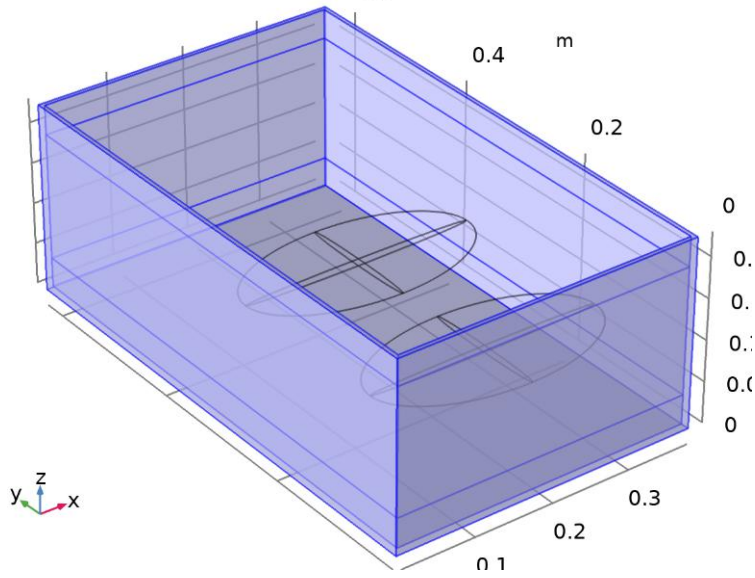

Selection

3.1.1.8 Bice Average

Probe type	Domain probe
------------	--------------

SELECTION

Geometric entity level	Domain
Selection	Domains 2, 4

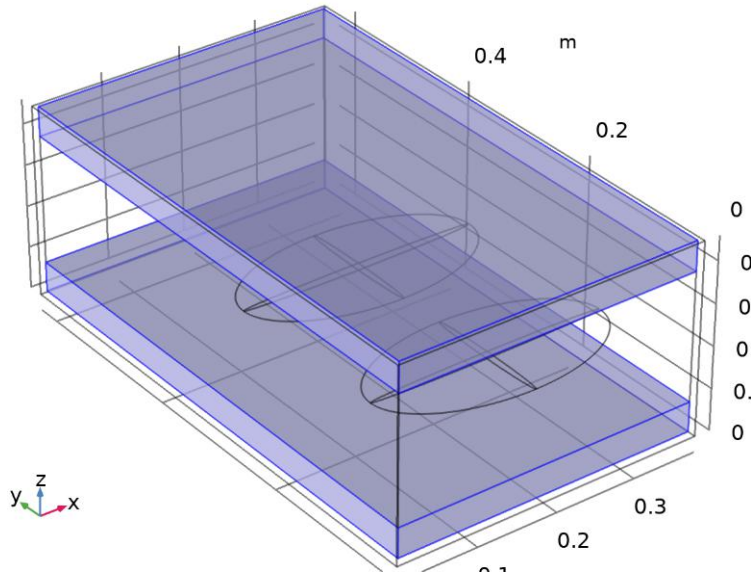

Selection

3.1.1.9 BFoam Maximum

Probe type Domain probe

SELECTION

Geometric entity level	Domain
Selection	Domain 1

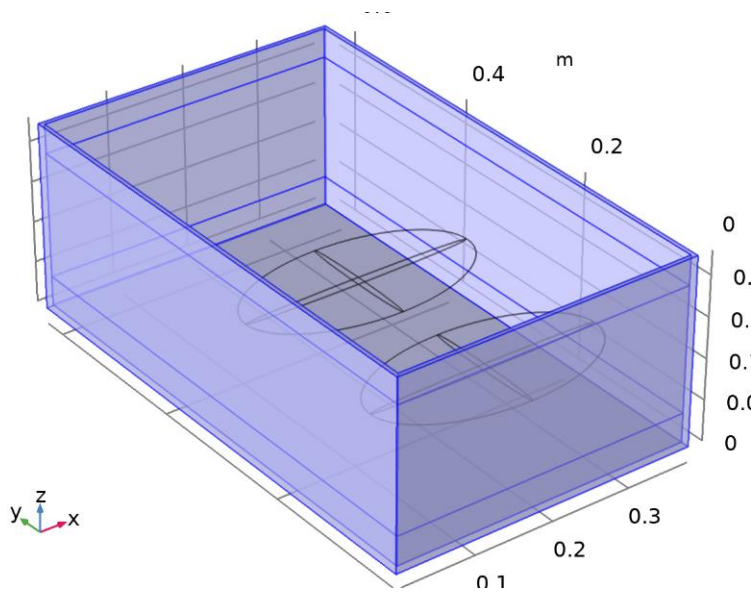

Selection

3.1.1.10 Ice temp

Probe type Domain probe

SELECTION

Geometric entity level	Domain
Selection	Domains 2, 4

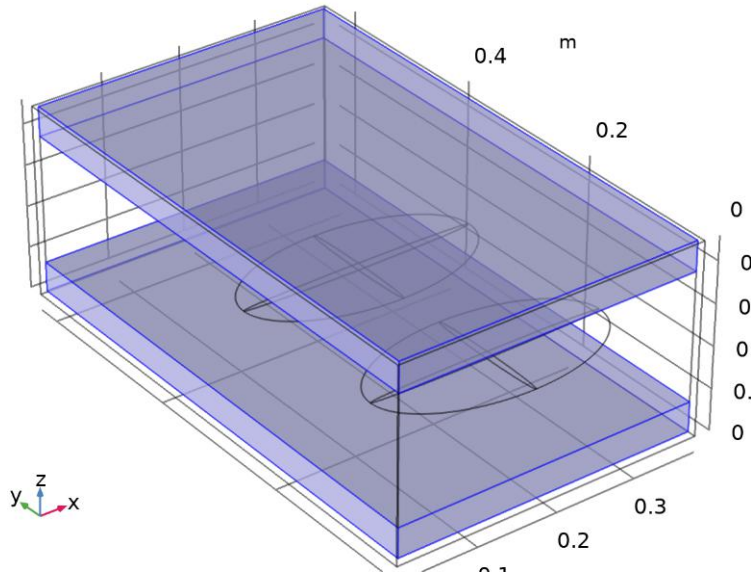

Selection

3.1.2 Coordinate Systems

3.1.2.1 Boundary System 2

Coordinate system type	Boundary system
Tag	sys2

COORDINATE NAMES

First	Second	Third
t1	t2	n

3.2 GEOMETRY 2

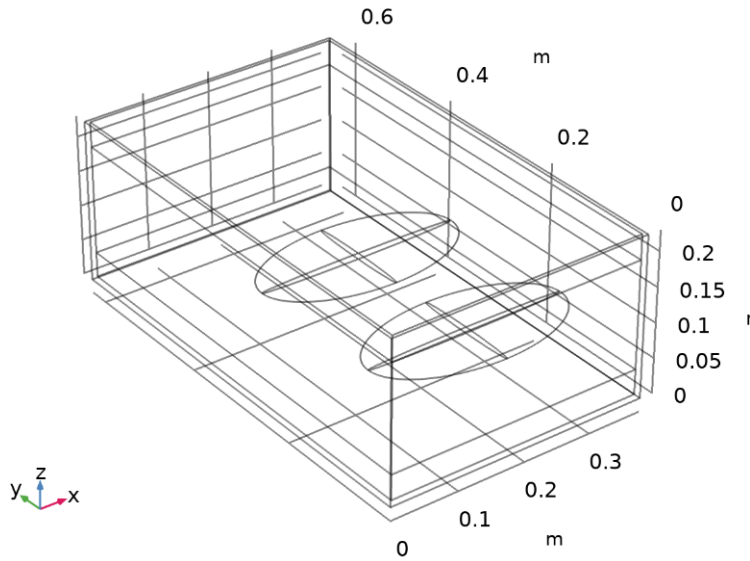

Geometry 2

UNITS

Length unit	m
Angular unit	deg

3.2.1 Box (blk1)

POSITION

Description	Value
Position	{0, 0, 0}

AXIS

Description	Value
Axis type	z - axis

SIZE AND SHAPE

Description	Value
Width	box_w
Depth	box_d
Height	box_h

3.2.2 IceTop (blk2)

POSITION

Description	Value
-------------	-------

Description	Value
Position	{Bdw, Bdd, Bdh + BBlock_h + Bice_h/2}

AXIS

Description	Value
Axis type	z - axis

SIZE AND SHAPE

Description	Value
Width	Bcontent_w
Depth	Bcontent_d
Height	Bice_h/2

3.2.3 IceBottom (blk3)

POSITION

Description	Value
Position	{Bdw, Bdd, Bdh}

AXIS

Description	Value
Axis type	z - axis

SIZE AND SHAPE

Description	Value
Width	Bcontent_w
Depth	Bcontent_d
Height	Bice_h/2

3.2.4 Fish/air (blk4)

POSITION

Description	Value
Position	{Bdw, Bdd, Bdh + Bice_h/2}

AXIS

Description	Value
Axis type	z - axis

SIZE AND SHAPE

Description	Value
-------------	-------

Description	Value
Width	Bcontent_w
Depth	Bcontent_d
Height	BBlock_h

3.2.5 Fish Corner (elp1)

POSITION

Description	Value
Position	{Bdw + BBlock_w/2, Bdd + fish_d + 0.02, Bdh + Bice_h/2 + BBlock_h/2}

AXIS

Description	Value
Axis type	z - axis

SIZE

Description	Value
a-semiaxis	fish_w
b-semiaxis	fish_d
c-semiaxis	fish_h

3.2.6 IceTop 1 (blk5)

POSITION

Description	Value
Position	{Bdw, Bdd, Bdh + BBlock_h + Bice_h/2}

AXIS

Description	Value
Axis type	z - axis

SIZE AND SHAPE

Description	Value
Width	Bcontent_w
Depth	Bcontent_d
Height	Bice_h/2

3.2.7 Fish middle (elp2)

POSITION

Description	Value
-------------	-------

Description	Value
Position	{Bdw + BBlock_w/2, Bdd + BBlock_d/2, Bdh + Bice_h/2 + BBlock_h/2}

AXIS

Description	Value
Axis type	z - axis

SIZE

Description	Value
a-semiaxis	fish_w
b-semiaxis	fish_d
c-semiaxis	fish_h

3.3 MATERIALS

3.3.1 Haddock

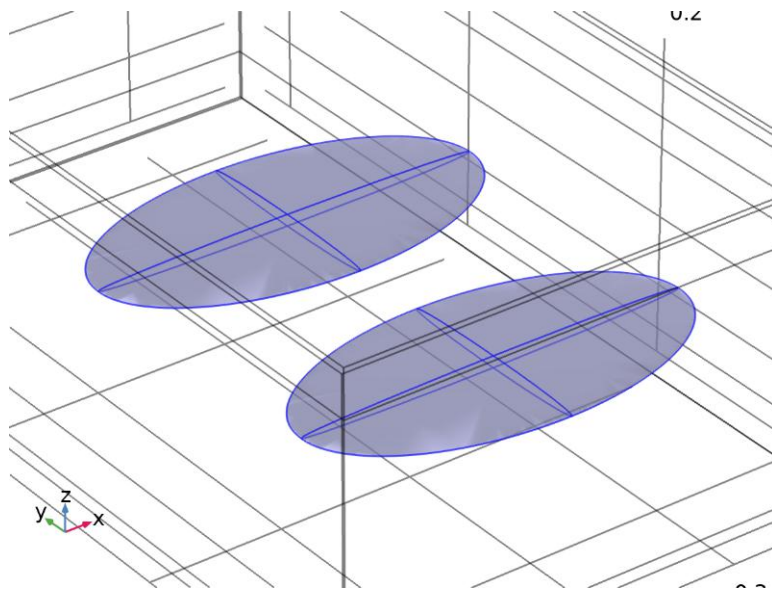

Haddock

SELECTION

Geometric entity level	Domain
Selection	Domains 5–6

MATERIAL PARAMETERS

Name	Value	Unit
Density	1054	kg/m ³
Heat capacity at constant pressure	3.73	J/(kg·K)

Name	Value	Unit
Thermal conductivity	0.43	W/(m·K)

3.3.2 Air

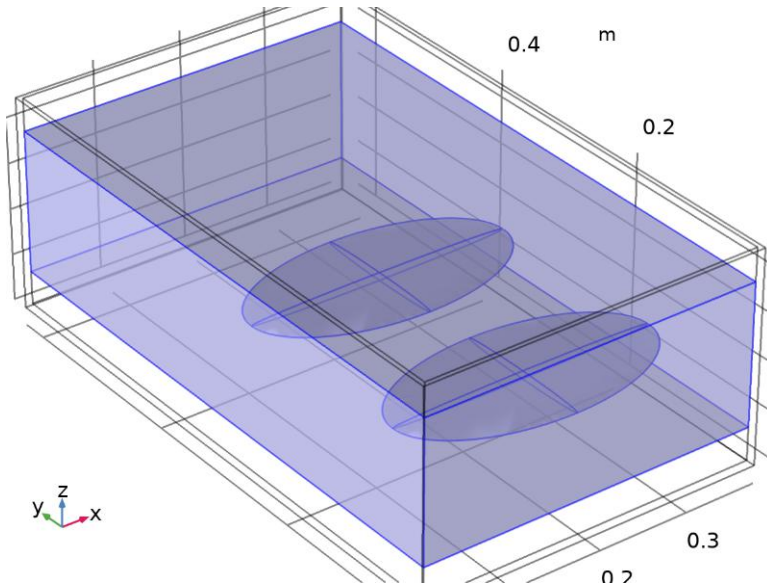

Air

SELECTION

Geometric entity level	Domain
Selection	Domain 3

MATERIAL PARAMETERS

Name	Value	Unit
Ratio of specific heats	1.4	1
Heat capacity at constant pressure	$C_p(T)$	J/(kg·K)
Density	$\rho(p_A, T)$	kg/m ³
Thermal conductivity	$k(T)$	W/(m·K)

3.3.3 Ice

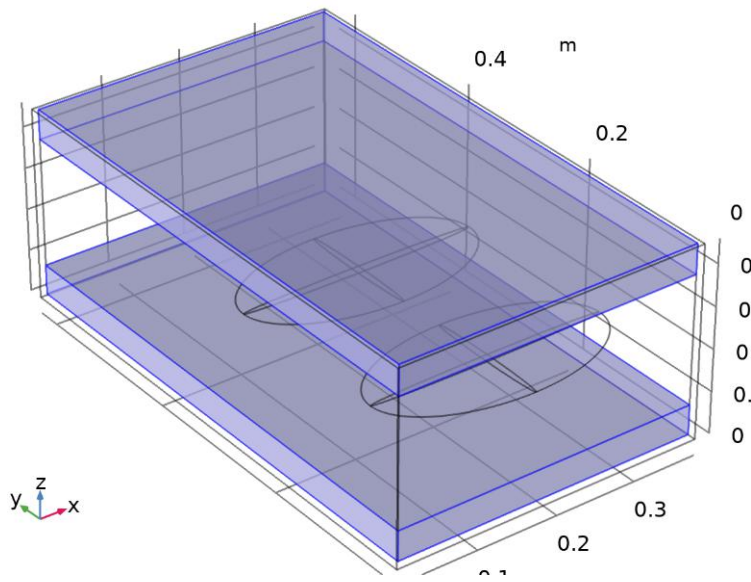

Ice

SELECTION

Geometric entity level	Domain
Selection	Domains 2, 4

MATERIAL PARAMETERS

Name	Value	Unit
Density	1000	kg/m ³

3.3.4 Water, liquid

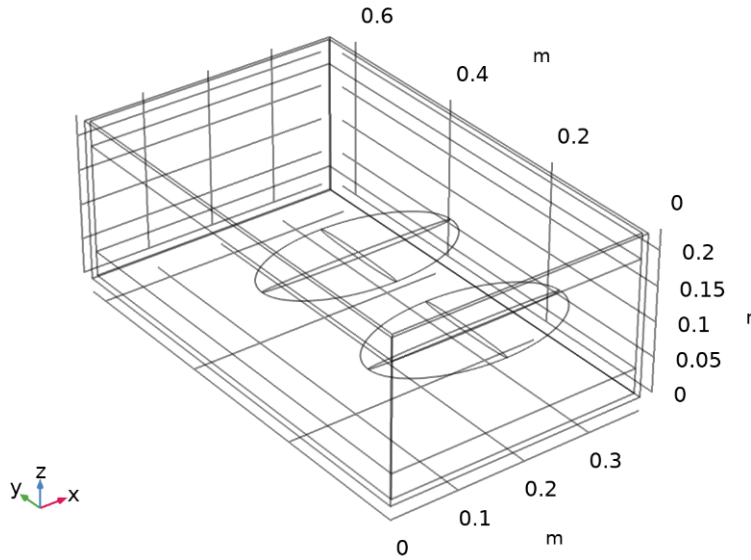

Water, liquid

SELECTION

Geometric entity level	Domain
Selection	No domains

3.3.5 HDPE (skin PE)

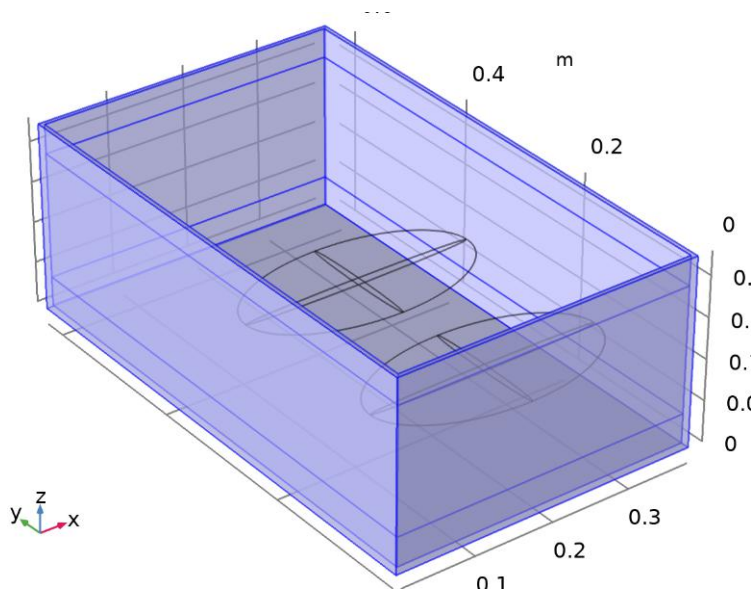

HDPE (skin PE)

SELECTION

Geometric entity level	Domain
------------------------	--------

Selection	Domain 1
-----------	----------

MATERIAL PARAMETERS

Name	Value	Unit
Thermal conductivity	0.44	W/(m·K)
Density	930	kg/m ³
Heat capacity at constant pressure	1.64*1000	J/(kg·K)

3.4 HEAT TRANSFER IN POROUS MEDIA 2

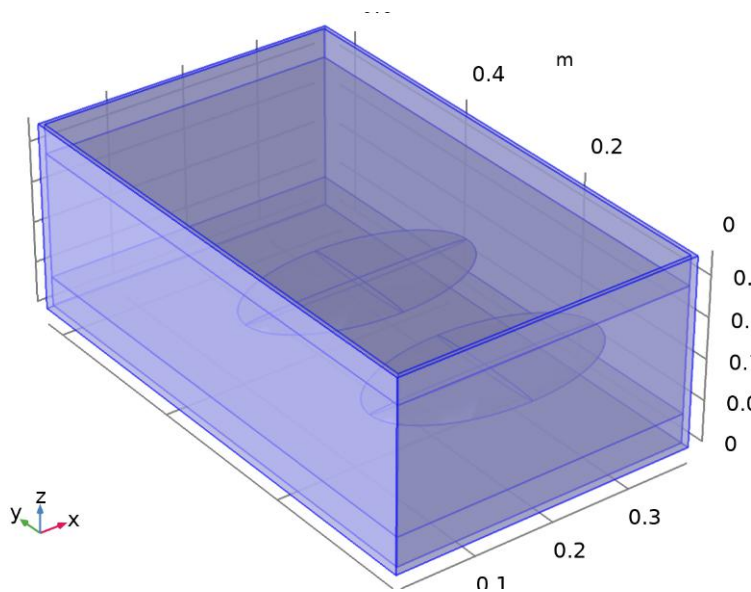

Heat Transfer in Porous Media 2

SELECTION

Geometric entity level	Domain
Selection	Domains 1–6

EQUATIONS

$$(\rho c_p)_{\text{eff}} \frac{\partial T_2}{\partial t} + \rho c_p \mathbf{u} \cdot \nabla T_2 + \nabla \cdot \mathbf{q} = Q + Q_{\text{vd}}$$

$$\mathbf{q} = -k_{\text{eff}} \nabla T_2$$

3.4.1 Interface settings

3.4.1.1 Discretization

SETTINGS

Description	Value
Temperature	Linear

3.4.1.2 Physical model

SETTINGS

Description	Value
Heat transfer in biological tissue	Off
Isothermal domain	Off
Heat transfer in porous media	On
Porous matrix model	Standard
Heat transfer in alloys	Off
Reference temperature	User defined
Reference temperature	293.15[K]

FEATURES

Porous Medium 1
Initial Values 1
Thermal Insulation 1
Solid Foam
Initial Foam
ICE
Initial Values ICE
Solid fish
Initial Fish
Heat Flux 1

3.4.2 Porous Medium 1

EQUATIONS

$$(\rho c_p)_{\text{eff}} \frac{\partial T_2}{\partial t} + \rho c_p \mathbf{u} \cdot \nabla T_2 + \nabla \cdot \mathbf{q} = Q + Q_p + Q_{\text{vd}}$$

$$\mathbf{q} = -k_{\text{eff}} \nabla T_2$$

$$(\rho c_p)_{\text{eff}} = \theta_p \rho_p c_{p,p} + (1 - \theta_p) \rho c_p$$

$$k_{\text{eff}} = \theta_p k_p + (1 - \theta_p) k + k_{\text{disp}}$$

3.4.3 Thermal Insulation 1

EQUATIONS

$$-\mathbf{n} \cdot \mathbf{q} = 0$$

3.4.4 Solid Foam

EQUATIONS

$$\rho c_p \frac{\partial T_2}{\partial t} + \rho c_p \mathbf{u} \cdot \nabla T_2 + \nabla \cdot \mathbf{q} = Q + Q_{\text{ted}}$$

$$\mathbf{q} = -k \nabla T_2$$

3.4.5 ICE

EQUATIONS

$$\rho c_p \frac{\partial T_2}{\partial t} + \rho c_p \mathbf{u} \cdot \nabla T_2 + \nabla \cdot \mathbf{q} = Q + Q_{\text{ted}}$$

$$\mathbf{q} = -k \nabla T_2$$

3.4.5.1 Phase Change Material 1

EQUATIONS

$$\rho = \rho_{\text{solid}}$$

$$c_p = \theta_1 c_{p1} + \theta_2 c_{p2} + L_{1 \rightarrow 2} \frac{\partial \alpha_m}{\partial T}$$

$$\alpha_m = \frac{1}{2} \frac{\theta_2 - \theta_1}{\theta_1 + \theta_2}$$

$$k = \theta_1 k_1 + \theta_2 k_2$$

$$\theta_1 + \theta_2 = 1$$

3.4.6 Solid fish

EQUATIONS

$$\rho c_p \frac{\partial T_2}{\partial t} + \rho c_p \mathbf{u} \cdot \nabla T_2 + \nabla \cdot \mathbf{q} = Q + Q_{\text{ted}}$$

$$\mathbf{q} = -k \nabla T_2$$

3.4.7 Heat Flux 1

EQUATIONS

$$-\mathbf{n} \cdot \mathbf{q} = q_0$$

$$q_0 = h(T_{\text{ext}} - T_2)$$

3.5 MESH 9

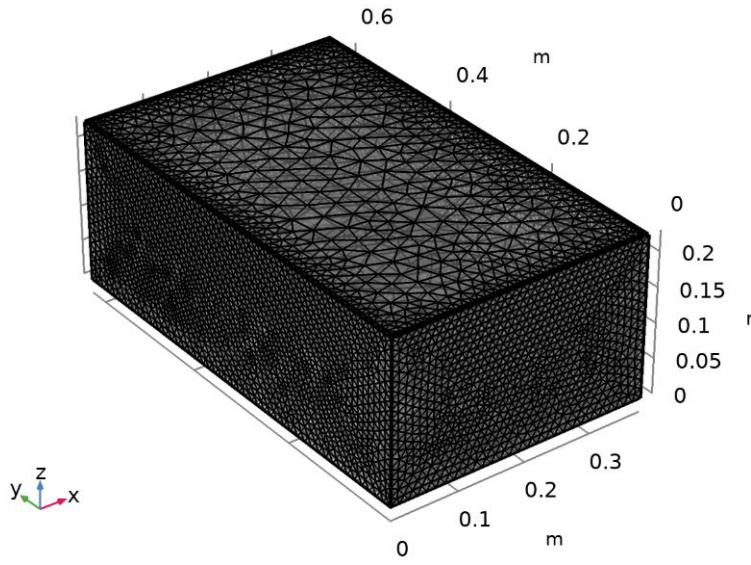

Mesh 9

4 Study 3

COMPUTATION INFORMATION

Computation time	49 min 30 s
CPU	Intel(R) Core(TM) i7-6500U CPU @ 2.50GHz, 2 cores
Operating system	Linux

4.1 TIME DEPENDENT

Times	Unit
range(0,0.5,24*5)	h

STUDY SETTINGS

Description	Value
Include geometric nonlinearity	Off

MESH SELECTION

Geometry	Mesh
mesh8	mesh8
mesh9	mesh9

PHYSICS AND VARIABLES SELECTION

Physics interface	Discretization
Heat Transfer in Porous Media (ht)	physics
Heat Transfer in Porous Media 2 (ht2)	physics

MESH SELECTION

Geometry	Mesh
Geometry 1 (geom1)	mesh8
Geometry 2 (geom2)	mesh9

5 Results

5.1 DATA SETS

5.1.1 Study 3/Solution 3 (1)

SOLUTION

Description	Value
Solution	Solution 3
Component	Save Point Geometry 1

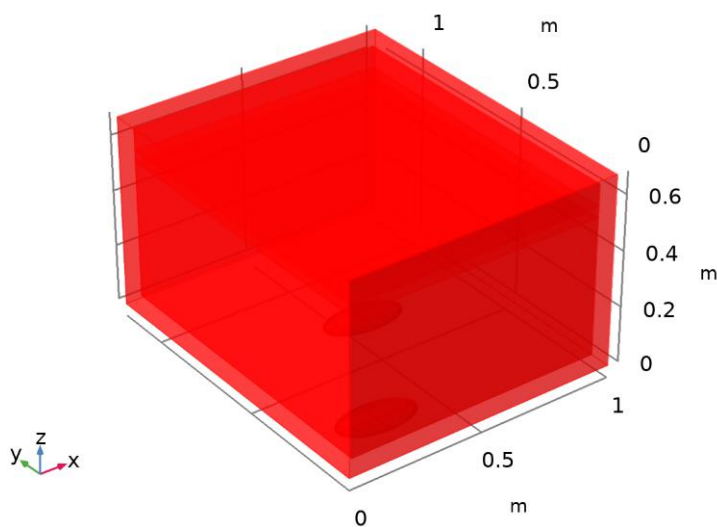

Data set: Study 3/Solution 3 (1)

5.1.2 Study 3/Solution 3 (2)

SOLUTION

Description	Value
Solution	Solution 3
Component	Save Point Geometry 2

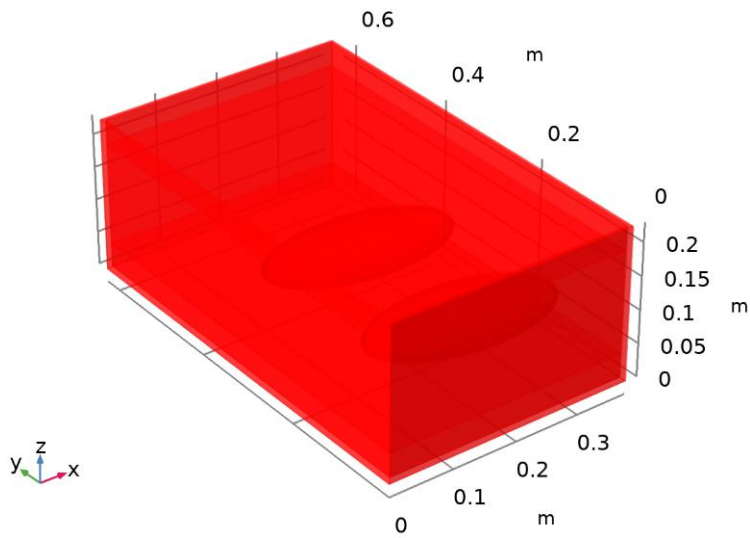

Data set: Study 3/Solution 3 (2)

5.1.3 Probe Solution 3

SOLUTION

Description	Value
Solution	Solution 3
Component	Save Point Geometry 1

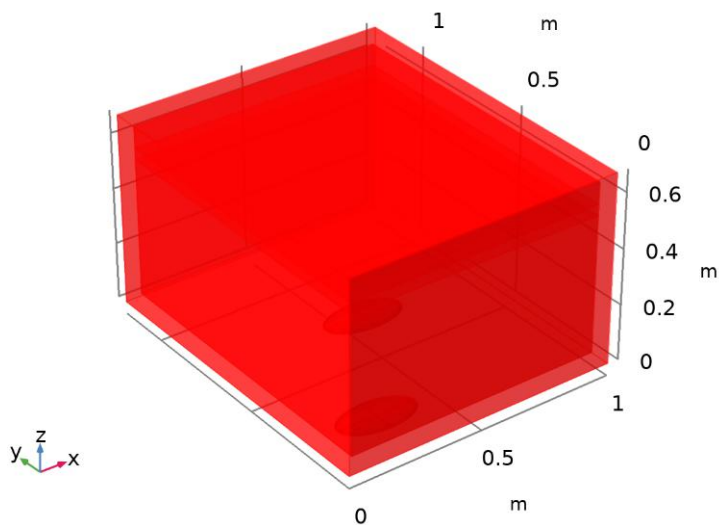

Data set: Probe Solution 3

5.1.4 TUB-max surface middle fish

SELECTION

Geometric entity level	Boundary
Selection	Boundaries 27–34

DATA

Description	Value
Data set	Probe Solution 3

SETTINGS

Description	Value
Element refinement	4

5.1.5 TUB-max surface corner fish

SELECTION

Geometric entity level	Boundary
Selection	Boundaries 19–25

DATA

Description	Value
Data set	Probe Solution 3

SETTINGS

Description	Value
Element refinement	4

5.1.6 TUB-Max

SELECTION

Geometric entity level	Domain
Selection	Domains 2, 5–6

DATA

Description	Value
Data set	Probe Solution 3

SETTINGS

Description	Value
Element refinement	4

5.1.7 TUB-Min

SELECTION

Geometric entity level	Domain
Selection	Domains 2, 5–6

DATA

Description	Value
Data set	Probe Solution 3

SETTINGS

Description	Value
Element refinement	4

5.1.8 Probe Solution 4

SOLUTION

Description	Value
Solution	Solution 3
Component	Save Point Geometry 2

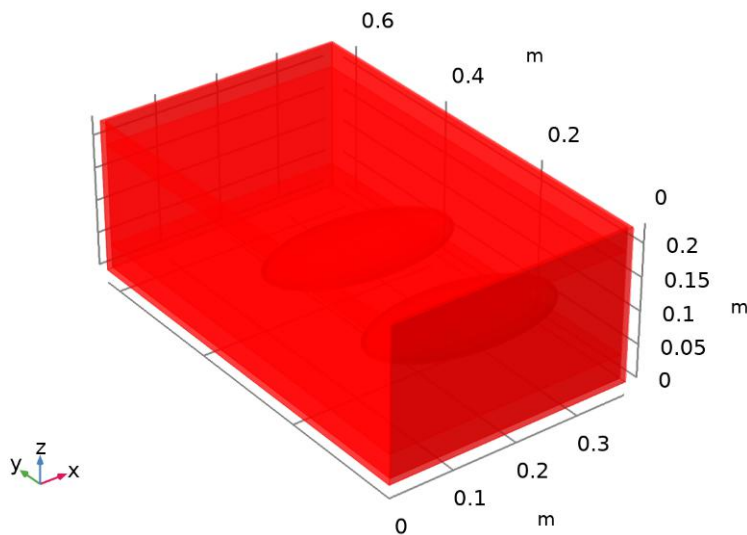

Data set: Probe Solution 4

5.1.9 BFoam Average

SELECTION

Geometric entity level	Domain
Selection	Domain 1

DATA

Description	Value
-------------	-------

Description	Value
Data set	Probe Solution 4

SETTINGS

Description	Value
Method	Integration
Integration order	4
Integration order	On

5.1.10 BIce Average

SELECTION

Geometric entity level	Domain
Selection	Domains 2, 4

DATA

Description	Value
Data set	Probe Solution 4

SETTINGS

Description	Value
Method	Integration
Integration order	4
Integration order	On

5.1.11 % top ice average

SELECTION

Geometric entity level	Domain
Selection	Domain 4

DATA

Description	Value
Data set	Probe Solution 4

SETTINGS

Description	Value
Method	Integration
Integration order	4
Integration order	On

5.1.12 % bottom ice average 1

SELECTION

Geometric entity level	Domain
Selection	Domain 2

DATA

Description	Value
Data set	Probe Solution 4

SETTINGS

Description	Value
Method	Integration
Integration order	4
Integration order	On

5.1.13 Air Average

SELECTION

Geometric entity level	Domain
Selection	Domain 4

DATA

Description	Value
Data set	Probe Solution 3

SETTINGS

Description	Value
Method	Integration
Integration order	4
Integration order	On

5.1.14 Ice Average temp

SELECTION

Geometric entity level	Domain
Selection	Domain 3

DATA

Description	Value
Data set	Probe Solution 3

SETTINGS

Description	Value
Method	Integration
Integration order	4
Integration order	On

5.1.15 %ice

SELECTION

Geometric entity level	Domain
Selection	Domain 3

DATA

Description	Value
Data set	Probe Solution 3

SETTINGS

Description	Value
Method	Integration
Integration order	4
Integration order	On

5.1.16 Water Average

SELECTION

Geometric entity level	Domain
Selection	Domain 2

DATA

Description	Value
Data set	Probe Solution 3

SETTINGS

Description	Value
Method	Integration
Integration order	4
Integration order	On

5.1.17 Water Maximum

SELECTION

Geometric entity level	Domain
------------------------	--------

Selection	Domain 2
-----------	----------

DATA

Description	Value
Data set	Probe Solution 3

SETTINGS

Description	Value
Element refinement	4

5.1.18 Foam average

SELECTION

Geometric entity level	Domain
Selection	Domain 1

DATA

Description	Value
Data set	Probe Solution 3

SETTINGS

Description	Value
Method	Integration
Integration order	4
Integration order	On

5.1.19 Foam maximum boundary

SELECTION

Geometric entity level	Boundary
Selection	Boundaries 1–5, 38

DATA

Description	Value
Data set	Probe Solution 3

SETTINGS

Description	Value
Element refinement	4

5.1.20 BFoam Maximum

SELECTION

Geometric entity level	Domain
Selection	Domain 1

DATA

Description	Value
Data set	Probe Solution 4

SETTINGS

Description	Value
Element refinement	4

5.1.21 BOX- max surface middle fish

SELECTION

Geometric entity level	Boundary
Selection	Boundaries 23–26, 31–34

DATA

Description	Value
Data set	Probe Solution 4

SETTINGS

Description	Value
Element refinement	4

5.1.22 BOX- max surface corner

SELECTION

Geometric entity level	Boundary
Selection	Boundaries 19–22, 27–30

DATA

Description	Value
Data set	Probe Solution 4

SETTINGS

Description	Value
Element refinement	4

5.1.23 BOX-max

SELECTION

Geometric entity level	Domain
Selection	Domains 3, 5–6

DATA

Description	Value
Data set	Probe Solution 4

SETTINGS

Description	Value
Element refinement	4

5.1.24 Probe Solution 5

SOLUTION

Description	Value
Solution	Solution 3
Component	Save Point Geometry 2
Frame	Geometry (Xg, Yg, Zg)

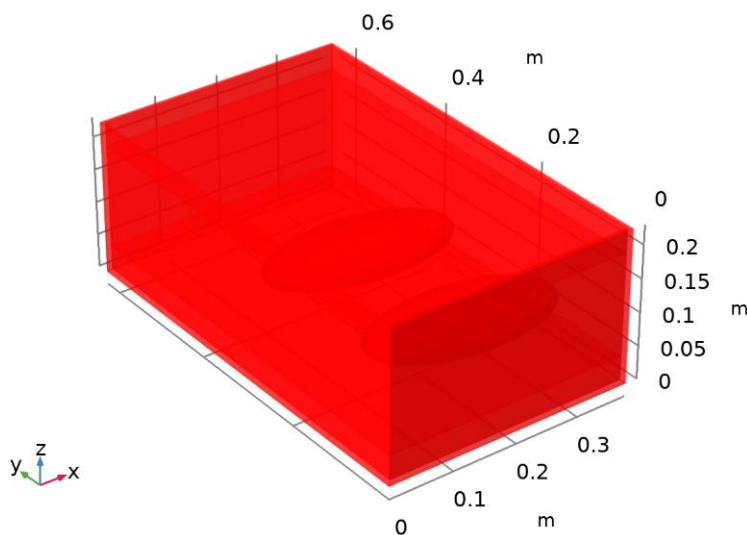

Data set: Probe Solution 5

5.1.25 BOX-min

SELECTION

Geometric entity level	Domain
Selection	Domains 3, 5–6

DATA

Description	Value
Data set	Probe Solution 5

SETTINGS

Description	Value
Element refinement	4

5.1.26 Ice temp

SELECTION

Geometric entity level	Domain
Selection	Domains 2, 4

DATA

Description	Value
Data set	Probe Solution 4

SETTINGS

Description	Value
Element refinement	4

5.2 DERIVED VALUES

5.2.1 TUB-max surface middle fish

OUTPUT

Evaluated in	Probe Table 1
--------------	---------------

DATA

Description	Value
Data set	TUB - max surface middle fish

EXPRESSIONS

Expression	Unit	Description
T	degC	Temperature

5.2.2 TUB-max surface corner fish

OUTPUT

Evaluated in	Probe Table 1
--------------	---------------

DATA

Description	Value
-------------	-------

Description	Value
Data set	TUB - max surface corner fish

EXPRESSIONS

Expression	Unit	Description
T	degC	Temperature

5.2.3 TUB-Max

OUTPUT

Evaluated in	Probe Table 1
--------------	---------------

DATA

Description	Value
Data set	TUB - Max

EXPRESSIONS

Expression	Unit	Description
T	degC	Temperature

5.2.4 TUB-Min

OUTPUT

Evaluated in	Probe Table 1
--------------	---------------

DATA

Description	Value
Data set	TUB - Min

EXPRESSIONS

Expression	Unit	Description
T	degC	Temperature

5.2.5 %ice

OUTPUT

Evaluated in	Probe Table 1
--------------	---------------

DATA

Description	Value
Data set	%ice

EXPRESSIONS

Expression	Unit	Description
ht.theta1	1	Phase indicator, phase 1

5.2.6 Outside Temp

OUTPUT

Evaluated in	Probe Table 1
--------------	---------------

DATA

Description	Value
Data set	Probe Solution 3

EXPRESSIONS

Expression	Unit	Description
Tout(t)	degC	T outside fridge 1

5.2.7 BOX- max surface middle fish

OUTPUT

Evaluated in	Probe Table 1
--------------	---------------

DATA

Description	Value
Data set	BOX - max surface middle fish

EXPRESSIONS

Expression	Unit	Description
T2	degC	Temperature

5.2.8 BOX- max surface corner

OUTPUT

Evaluated in	Probe Table 1
--------------	---------------

DATA

Description	Value
Data set	BOX - max surface corner

EXPRESSIONS

Expression	Unit	Description
T2	degC	Temperature

5.2.9 BOX-max

OUTPUT

Evaluated in	Probe Table 1
--------------	---------------

DATA

Description	Value
Data set	BOX - max

EXPRESSIONS

Expression	Unit	Description
T2	degC	Temperature

5.2.10 BOX-min

OUTPUT

Evaluated in	Probe Table 1
--------------	---------------

DATA

Description	Value
Data set	BOX - min

EXPRESSIONS

Expression	Unit	Description
T2	degC	Temperature

5.2.11 % top ice average

OUTPUT

Evaluated in	Probe Table 1
--------------	---------------

DATA

Description	Value
Data set	% top ice average

EXPRESSIONS

Expression	Unit	Description
ht2.theta1	1	Temperature

5.2.12 % bottom ice average 1

OUTPUT

Evaluated in	Probe Table 1
--------------	---------------

DATA

Description	Value
Data set	% bottom ice average 1

EXPRESSIONS

Expression	Unit	Description
ht2.theta1	1	Temperature

5.2.13 Air Average

OUTPUT

Evaluated in	Probe Table 1
--------------	---------------

DATA

Description	Value
Data set	Air Average

EXPRESSIONS

Expression	Unit	Description
T	degC	Temperature

5.2.14 Ice Average temp

OUTPUT

Evaluated in	Probe Table 1
--------------	---------------

DATA

Description	Value
Data set	Ice Average temp

EXPRESSIONS

Expression	Unit	Description
T	degC	Temperature

5.2.15 Water Average

OUTPUT

Evaluated in	Probe Table 1
--------------	---------------

DATA

Description	Value
Data set	Water Average

EXPRESSIONS

Expression	Unit	Description
T	degC	Temperature

5.2.16 Water Maximum

OUTPUT

Evaluated in	Probe Table 1
--------------	---------------

DATA

Description	Value
Data set	Water Maximum

EXPRESSIONS

Expression	Unit	Description
T	degC	Temperature

5.2.17 Foam average

OUTPUT

Evaluated in	Probe Table 1
--------------	---------------

DATA

Description	Value
Data set	Foam average

EXPRESSIONS

Expression	Unit	Description
T	degC	Temperature

5.2.18 Foam maximum boundary

OUTPUT

Evaluated in	Probe Table 1
--------------	---------------

DATA

Description	Value
Data set	Foam maximum boundary

EXPRESSIONS

Expression	Unit	Description
T	degC	Temperature

5.2.19 BFoam Average

OUTPUT

Evaluated in	Probe Table 1
--------------	---------------

DATA

Description	Value
Data set	BFoam Average

EXPRESSIONS

Expression	Unit	Description
T2	degC	Temperature

5.2.20 BIce Average

OUTPUT

Evaluated in	Probe Table 1
--------------	---------------

DATA

Description	Value
Data set	BIce Average

EXPRESSIONS

Expression	Unit	Description
T2	degC	Temperature

5.2.21 BFoam Maximum

OUTPUT

Evaluated in	Probe Table 1
--------------	---------------

DATA

Description	Value
Data set	BFoam Maximum

EXPRESSIONS

Expression	Unit	Description
T2	degC	Temperature

5.2.22 Ice temp

OUTPUT

Evaluated in	Probe Table 1
--------------	---------------

DATA

Description	Value
Data set	Ice temp

EXPRESSIONS

Expression	Unit	Description
T2	degC	Temperature

5.3 PLOT GROUPS

5.3.1 TUB fish

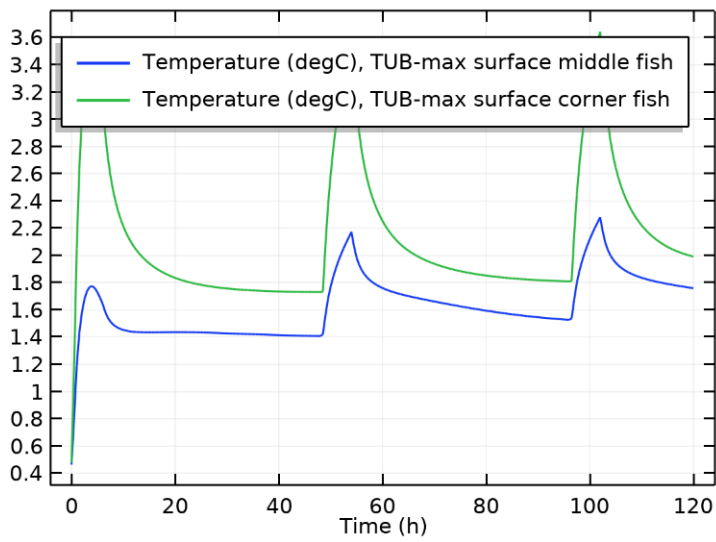

5.3.2 BOX fish

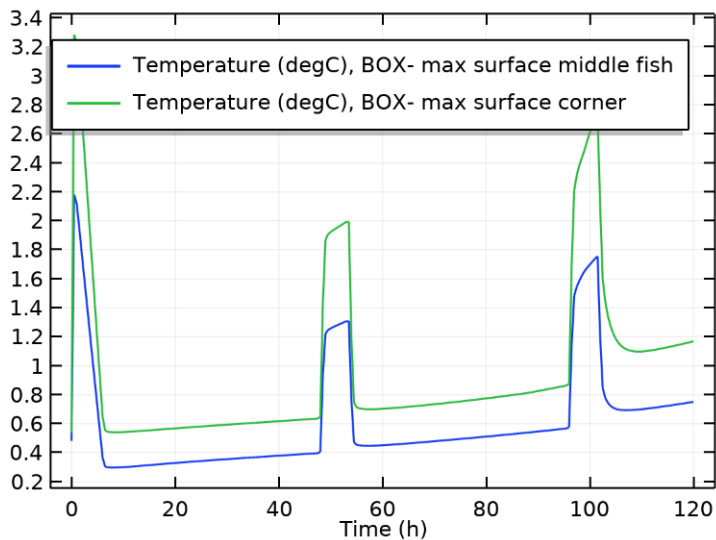

5.3.3 TUB Several

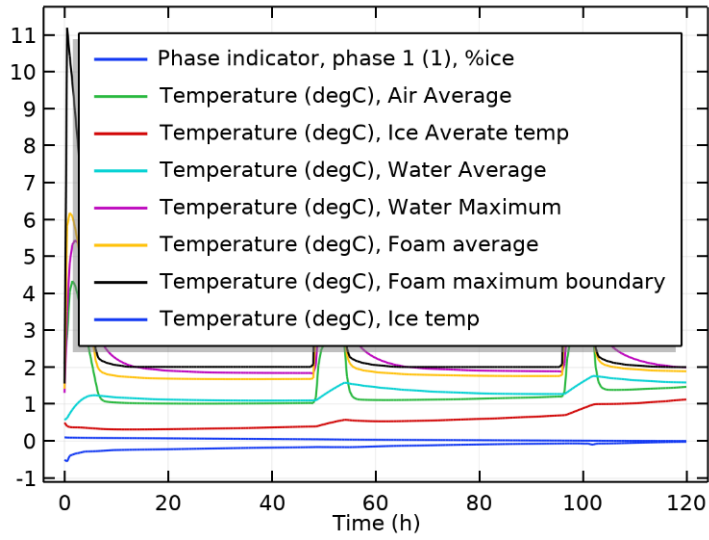

5.3.4 BOX several

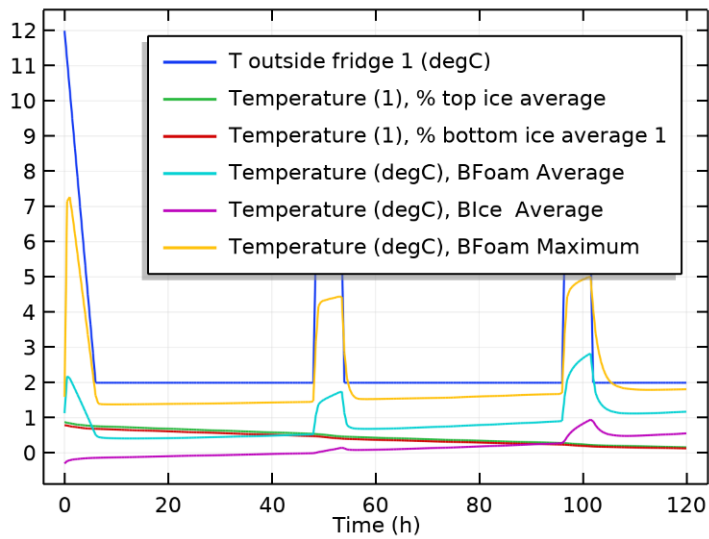

5.3.5 Comparison TUB-BOX

