

Why set up a modelling SME when you are student?

- the economic impact of QuickWave software

Dr. Malgorzata Celuch

President & Senior Scientist,
QWED Sp. z o.o., Poland

electromagnetic modelling as *science* & as *business*



www.qwed.eu

mceluch@qwed.eu



www.mmama.org



Acknowledgements

The present work on QuickWave software applications to material measurements receives funding from the *European Union's Horizon 2020* research and innovation programme (H2020-NMBP-07-2017) under grant agreement *MMAMA n°761036*.
(website: www.mmama.eu)

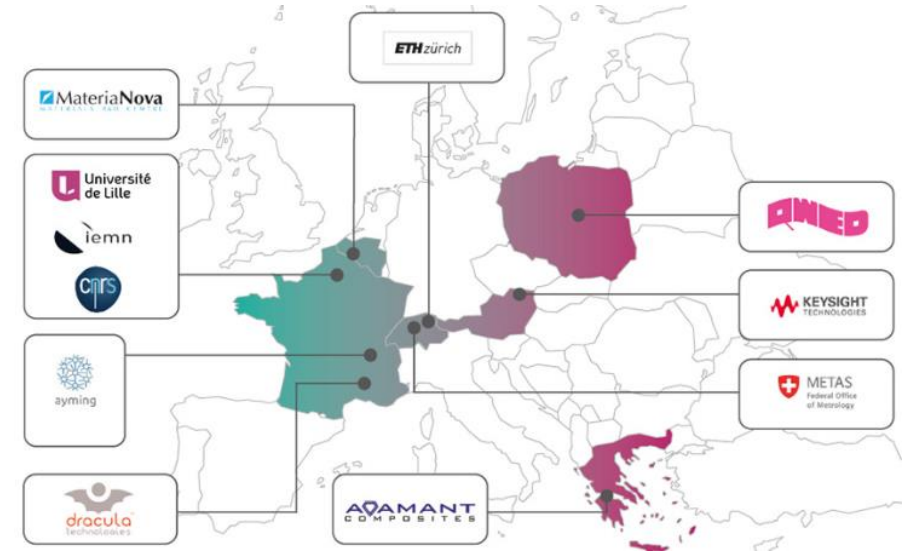

Simulations were conducted with QuickWave EM software, developed & commercialised (since 1997) by QWED.

The original designs of QWED resonators for material measurements were from Prof. Jerzy Krupka, e.g.:

J. Krupka, A. P. Gregory, O. C. Rochard, R. N. Clarke, B. Riddle, and J. Baker-Jarvis, "Uncertainty of complex permittivity measurements by split-post dielectric resonator technique", *J. Eur. Ceramic Soc.*, vol. 21, pp. 2673-2676, 2001.

J. Krupka and J. Mazierska, "Contactless measurements of resistivity of semiconductor wafers employing single-post and split-post dielectric-resonator techniques," *IEEE Trans. Instr. Meas.*, vol. 56, no. 5, pp. 1839-1844, Oct. 2007.

Microwave heating scenarios & concepts by Per O. Risman, Microtrans AB & Malardalen University, Sweden.

Outline

- **Electromagnetic modelling as science**
 - what is EM modelling and how it relates to materials
 - my PhD studies & 3D FDTD "Copernicus version" in 1994-1996
- **Electromagnetic modelling as business**
 - QuickWave by QWED & economic impact on QWED
 - economic impact on QWED customers & partners
- **Modelling workflows in QuickWave that stimulate "transfers of technology"**
 - "*near field imaging*" from MW heating
 - multiphysics modelling of MW heating
 - common CAD interfaces
 - sub-cellular models in FDTD (*hints*)
 - "*near field imaging*" in antenna design
 - material data: between simulations & measurements
- **User stories.. scattered throughout the slides**



Electromagnetic modelling for microwave technology

Microwaves (MW) – EM waves formally of GHz range – here: modelling from below MHz to hundreds of THz

Electromagnetic (EM) modelling =

= solving **Maxwell** equations with **boundary** & **initial** conditions subject to material **constitutive** relations

$$\nabla \times \vec{E} = -\frac{\partial \vec{B}}{\partial t}$$

$$\oint_l \vec{E} \cdot d\vec{l} = -\frac{d}{dt} \iint_s \vec{B} \cdot \vec{n} \, ds$$

$$\nabla \times \vec{H} = \frac{\partial \vec{D}}{\partial t} + \vec{J}$$

$$\oint_l \vec{H} \cdot d\vec{l} = \iint_s \left(\vec{J} + \frac{\partial \vec{D}}{\partial t} \right) \cdot \vec{n} \, ds$$

$$\nabla \cdot \vec{D} = \rho$$

$$\oiint_s \vec{D} \cdot \vec{n} \, ds = \iiint_V \rho \, dv$$

$$\nabla \cdot \vec{B} = 0$$

$$\oiint_s \vec{B} \cdot \vec{n} \, ds = 0$$

$$\nabla \cdot \vec{J} = -\frac{\partial \rho}{\partial t}$$

$$\oiint_s \vec{J} \cdot \vec{n} \, ds = -\iiint_V \frac{\partial \rho}{\partial t} \, dv$$

general:

$$\vec{D}, \vec{B}, \vec{J} = \vec{F}(\vec{E}, \vec{H})$$

typical:

$$\vec{D} = \underline{\underline{\epsilon}} \cdot \vec{E}$$

$$\vec{B} = \underline{\underline{\mu}} \cdot \vec{H}$$

$$\vec{J} = \underline{\underline{\sigma}} \cdot \vec{E}$$



EMMC Turin 2019



Two perspectives of EM modelling (continuum, physics-based)	
EM wave propagation in space (also in-between boundaries)	EM field interaction with materials
1990s: radars, radio & TV, electronic circuits	MW ovens
today: telecommunications (5G), RFID (ski-pass), IoT (wearable sensors)	biomedical (diagnostics – breast cancer, treatment – hyperthermia) MW chemistry, wood drying, plastics curing, rock comminution

"Modelling" for microwave technology: my *personal* view of history

Until 1980s:

- heuristic equations (experimental models; today: data based?)
- lumped circuit approximations (**0-dimensional**: dimensions \ll wavelength)
- **1D** approximations (transmission lines, long lines, telegraphists equations, Smith chart)

In 1980-1990s:

- academic research on solving Maxwell eqs.

dimensionality in space	fields in space	fields in time
2D	modal expansions (method of moment, mode matching...)	monochromatic (frequency-domain approach)
3D	discretisation (FEM , FD, FV, TLM, SpN,..)	arbitrary (time-domain approach)

- commercial software packages implemented in industry

Engineers question in 1990s: will EM software help me?

Engineers question today: can I trust EM software (to fully replace hardware prototyping)?



EMMC Turin 2019



FDTD modelling at the Warsaw University of Technology in 1980-1990s

W.K.Gwarek, "Analysis of an arbitrarily-shaped planar circuit - a time-domain approach", **invited paper**, *IEEE Trans. Microwave Theory Tech.*, vol.33, No.10, Oct.1985.

W.Gwarek, "Computer-aided analysis of arbitrarily-shaped coaxial discontinuities", *IEEE Trans. Microwave Theory Tech.*, vol.36, No.2, Feb.1988.

→ [QuickWave 2D launched onto the market by ArguMens GmbH](#)

M.Celuch-Marcysiak & W.Gwarek, "Formal equivalence and efficiency comparison of the FD-TD, TLM and SN methods in application to microwave CAD programs", *Proc. 21st European Microwave Conf.*, Stuttgart, Sept. 1991.

→ [FDTD and TLM and SN are formally equivalent but FDTD is computationally more efficient \(and opens way to conformal modelling\)](#)

PUBLICATIONS IN ENDLESS REVIEWS → DECISION TO PROVE OUR POINT ON THE MARKET
EC SUPPORT via COPERNICUS PROJECT 1994-1996 INTERRUPTED...

BUSINESS BORN OUT OF OBSTACLES?..

M.Celuch-Marcysiak, "Time-domain approach to microwave circuit modeling: a view of general relations between TLM and FDTD", **invited paper**, *Intl. Journal of Microwave and Millimeter-Wave Computer Aided Engineering*, vol.6, No.1, 1996.

M.Celuch-Marcysiak, W.K.Gwarek, "On the nature of solutions produced by finite difference schemes in time domain", **invited paper**, *Int.Journal of Numerical Modelling*, vol.12, No. 1-2, Jan.-Apr.1999.

M.Celuch-Marcysiak & W.K.Gwarek, "Generalized TLM algorithms with controlled stability margin and their equivalence with finite-difference formulations for **modified** grids", *IEEE Trans. Microwave Theory Tech.*, vol. MTT-43, No.9, Sep.1995.

→ [TLM can be made as good as FDTD](#)

International research context:

K.S.Yee, "Numerical solution of initial boundary-value problems involving Maxwell's equations in isotropic media", *IEEE Trans.Ant.Prop.*, vol.14, No.5, 1966.

A.Taflove, M.E.Bodwin, "Numerical solution of steady state electromagnetic scattering problems using the time dependent Maxwell's equations", *IEEE Trans. Microwave Theory Tech.*, vol.33, No.10, Oct.1985.

A.Taflove, S.Hagness, (with chapters co-authored by M.Celuch & W.Gwarek) "Computational Electrodynamics - The Finite-Difference Time-Domain Method", 3rd Edition, Artech House, Boston-London, 2005.



Why set up a business when you are a PhD student...

Why set up a business? Online at (as of 27 June 2019): <https://www.bbc.com/bitesize/guides/zc3gkqt/revision/1>

"Setting up a business involves **risks** and **reward**.
Profit is the **reward** for risk-taking.
Losses are the **penalty** of business failure."

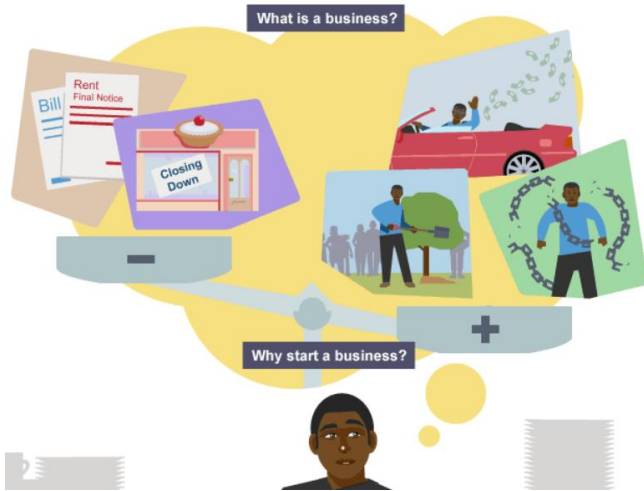

Why set up a business (expected **award)? (*none in my case...*)**

- making a **profit**
- **satisfaction** of being independent
- **satisfaction** of being able to make a difference (e.g. charity)
- ...

My reward (expected & achieved):

satisfaction of being able to prove my research concept
with unexpected "penalty" being... **responsibility!**

How set up a business?

"An entrepreneur knows that setting up in business is a **risk**.
They need a robust **business plan** detailing market research
and **competitor analysis** and a good knowledge of the market."

I knew or did little of the above...



EMMC Turin 2019



"Marketing" of QuickWave was all based on need & trust

1. People trusted us based on our documented research results
2. We trusted our own choices & solutions, and were not afraid of challenges:

"During this early period QWED had a client (..), developing filters. They had problems with the differences between the experimental and modelling results. Andrzej W. worked on that and after some time found out that the discrepancy was a 1 or 2 μm wide air or oxide gap between two connecting metal parts. He solved the whole thing very impressively, and that would not have been possible with a FEM method I think. "

3. We were not afraid to develop new functionalities from scratch
(e.g. ferrite model for crisp plates was provided to a customer in 2 weeks from the first enquiry)
4. Our clients were becoming our marketing force

4. We also trusted what our expert users told us about the market:

"With my knowledge of the weaknesses of FEM and FDTD I was encouraged to arrange a competition, in 1999 I think. This was between four vendors, two FDTD and two FEM (..). One of the scenarios was a rectangular waveguide very near cut-off, which was the most interesting of the examples. – Only QWED solved that correctly, and I remember the US expert of an US vendor calling me in the middle of the night over the "impossibility to solve the damned problem". (..) I presented to outcome of the test at an IMPI symposium. That evidently resulted in QWED getting some new clients."

..and we underestimated that the popular market prefers "easy" to "accurate" ...
..and I underestimated the burden of responsibility (towards users & employees)



EMMC Turin 2019





Polish high-tech SME - 22 years on the world's market

Business branches presented annually at IEEE IMS Show

R&D projects

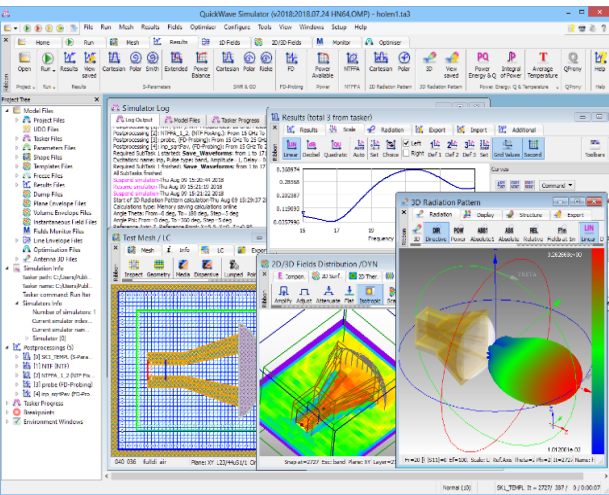

Electromagnetic simulation & design software, 3D & BOR 2D tools

based on 300+ publications by: prof.W.Gwarek, IEEE Fellow, DML, Pioneer Award dr.M.Celuch, President of QWED



PREZES RADY MINISTRÓW
przyznaje III nagrodę
za wybitne krajowe osiągnięcia naukowo-techniczne
zmpolowi Politechniki Warszawskiej w składzie:
dr inż. Małgorzata CELUCH-MARCYSIAK, dr inż. Maciej STPNIIEWSKI,
dr inż. Andrzej WĘCISZCOWSKI
pod kierownictwem: prof. dr hab. inż. Włodzisława GWAREK

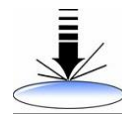

FP6 SOCOT – development and validation of an optimal methodology for overlay control in semiconductor industry, for the 32 nm technology node and beyond.

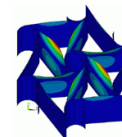

FP6 CHISMACOMB – development, modelling, and applications of chiral materials → EM validation of mixing rules



Eureka E! 2602 MICRODEFROST MODEL – innovative software-based product development tool for simulating and optimising heating and defrosting processes in microwave ovens



FP7 HIRF SE (High Intensity Radiated Field Synthetic Environment) - numerical modelling framework for aeronautic industry



Eureka FOODWASTE – developing new microwave treatment system for high water content waste



ERA-NET MNT NACOPAN – applications and modelling of nano-conductive polymer composites



NGAM2 – designing an industrial device for thermal bonding of bituminous surfaces with the aid of microwave heating



MMAMA (Microwave Microscopy for Advanced and Efficient Materials Analysis and Production) – accelerating the development of high efficiency solar cells through application and enhancement of material measurement techniques

Test-fixtures for precise material measurements based on 300+ publications

by prof.J.Krupka, IEEE Fellow

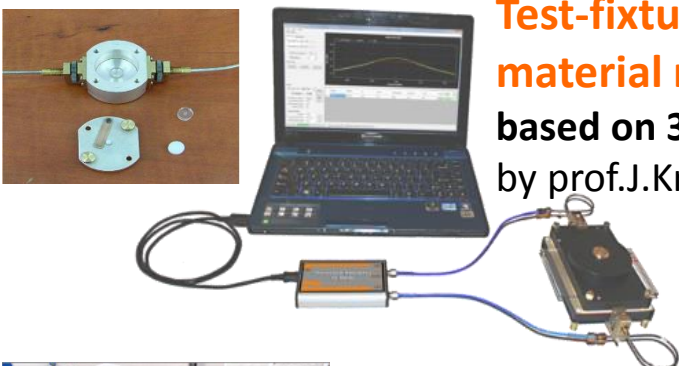

Consultancy & design services based on EM expertise & tools

team of 10+engineers, 4 PhDs, 2 Profs
key areas: MW power appliances, customised resonators, antennas & feeds

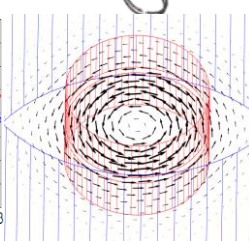
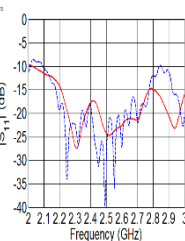

EMED Electromagnetic modelling and design – antennas & feed systems

QuickWave-3D:

world's recognised 3D EM simulation tool

Space research:
 NASA related laboratories:
National Radio Astronomy Observatory (VA US),
Jet Propulsion Laboratory (CA US)
 Universities:
CALTECH (US), Chalmers (S), etc.

Antenna feed systems designed by NRAO

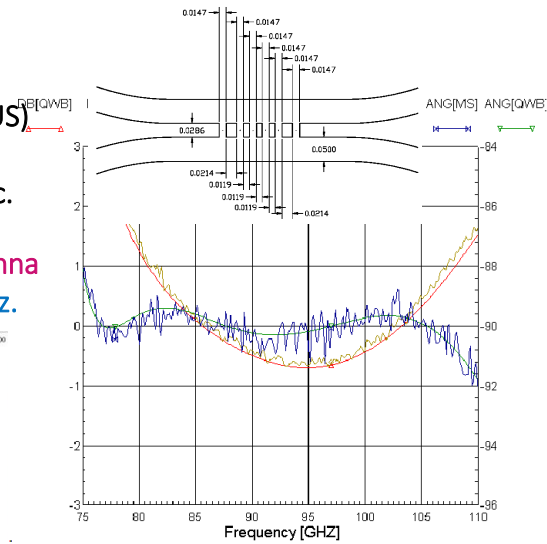

QuickWave 3D results at NRAO, see: **ALMA Memos 381, 343, 325, 278.**

QuickWave BOR:

unique on the market & ultrafast tool for axisymmetrical structures

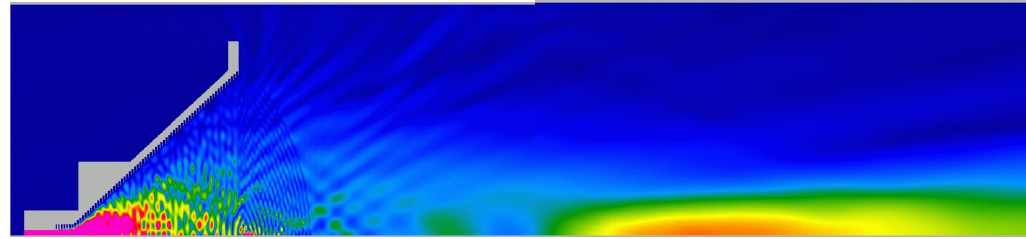

Antennas as large as **2600 λ** in diameter on moderate PC

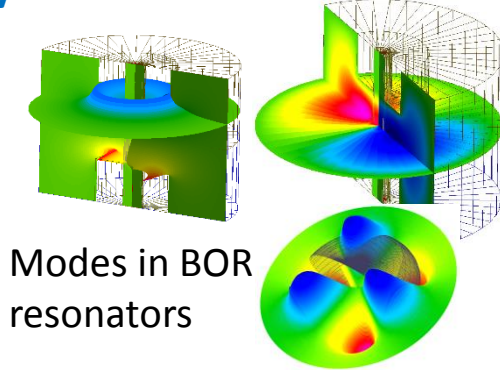

Modes in BOR resonators

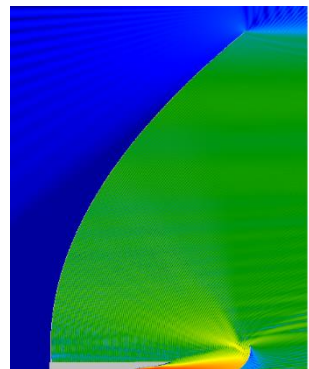

Insight into EM near-field helps explain causes of undesired performance

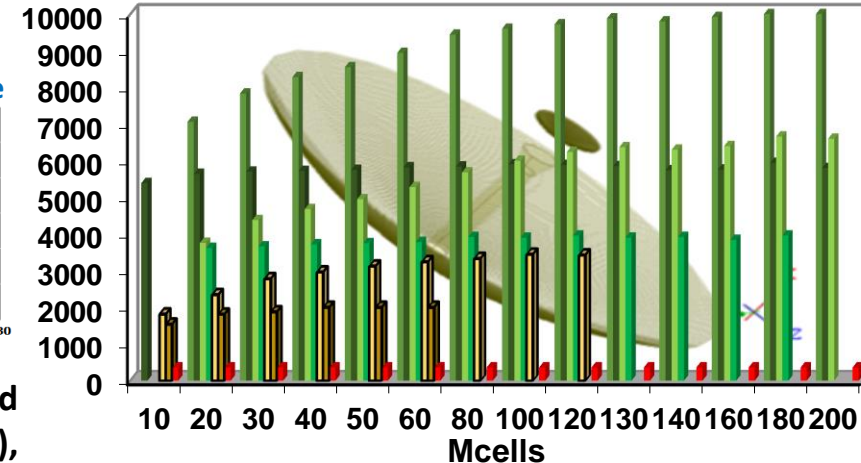
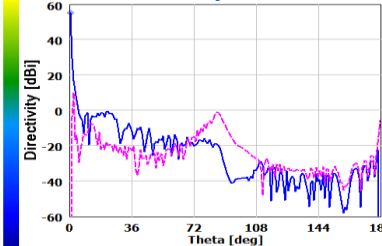

QuickWave is optimised for speed plotted in (Mcells/sec), runs on professional & low-cost video cards:

Pioneering background:

W.Gwarek, *IEEE Trans. MTT*: vol.33 Oct.1985; vol.36 Feb. & Apr. 1988.

Key developments:

M.Celuch & W.Gwarek, *IEEE Trans. MTT*, vol.43 Sep.1995, vol.41 May1993, vol.45 May1997, vol.51 Aug.2003; *EuMC* 1991-1997; *IEEE IMS* 2001-2004.

Reviews: *IEEE Microwave Mag.*, Dec.2008 & Apr.2010; *IJMP* vol.41 2007.

Balanced antipodal Vivaldi antenna & 3D radiation pattern at 10 GHz.

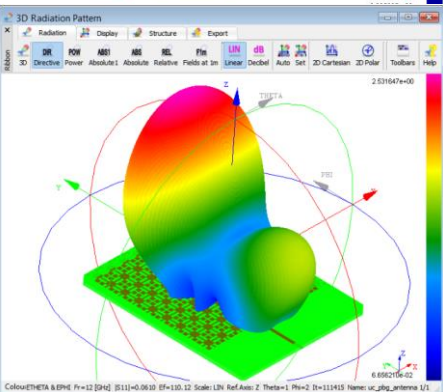
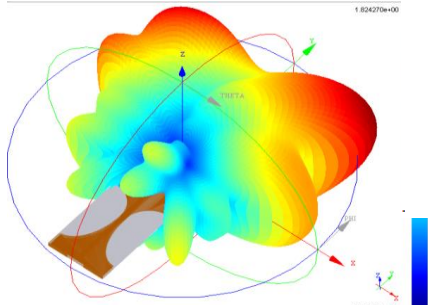

Aperture-coupled patch antenna on uniplanar photonic bandgap substrate & its radiation pattern at 12 GHz.

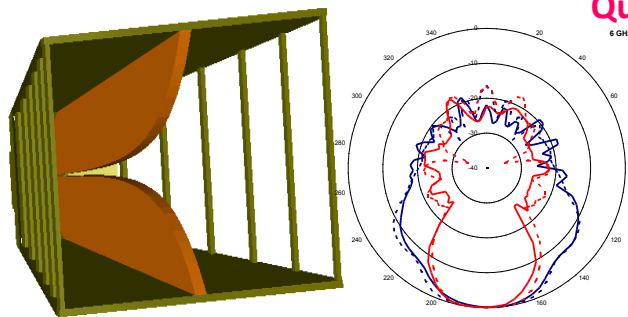

Pyramidal horn antenna for military surveillance measured (courtesy prof.B.Stec) & simulated patterns

QWED Electromagnetic consulting & design – high MW power applications

Modelling of MW heating effects in domestic oven

Full-wave EM simulation & heat transfer & load dynamics
 Load rotation & arbitrary movement during heating
 Source frequency tuning – regime for solid state sources
 Temperature dependence of material parameters

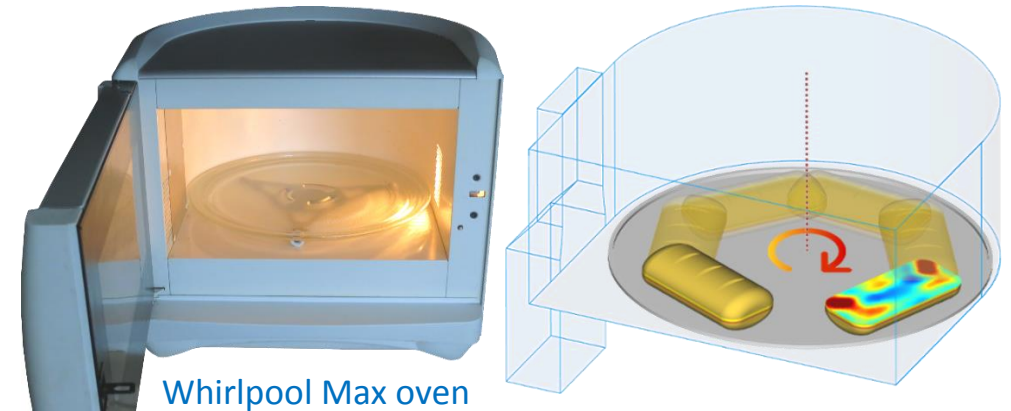

Whirlpool Max oven

Considered by M.Celuch & P.Kopyt in eds. W. Lorence and P. S. Pesheck, *Development of packaging and products for use in microwave ovens*, 1st edition Woodhouse CRC Press 2009, 2nd Ed. Elsevier in print.

QuickWave modelling of heating confirmed by real-life experiments – joint work of QWED and WUT in Eureka E!2602 project

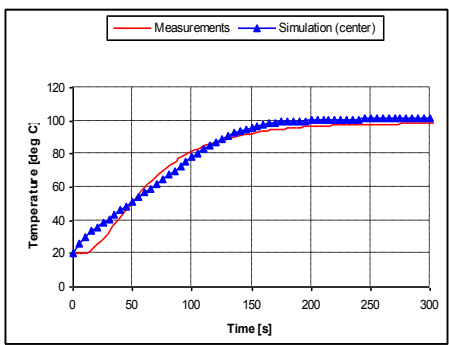
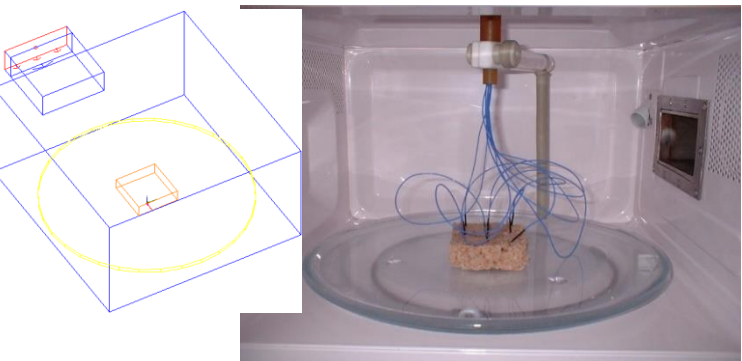

Free-fall waste processing on ships (Eureka FOODWASTE)

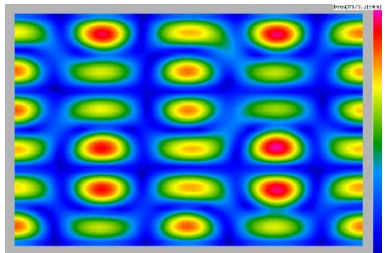

E-field in horizontal & vertical cut

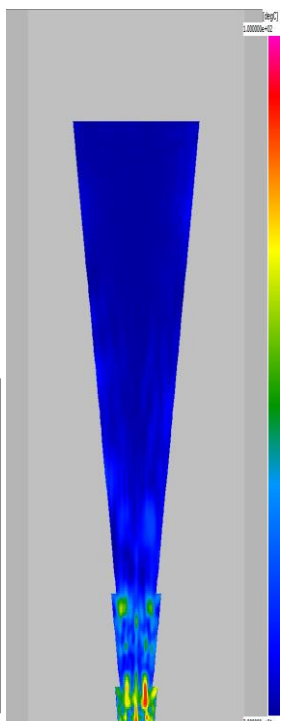

High power applicator for MW treatment of bituminous surfaces (road repair, NGAM project)

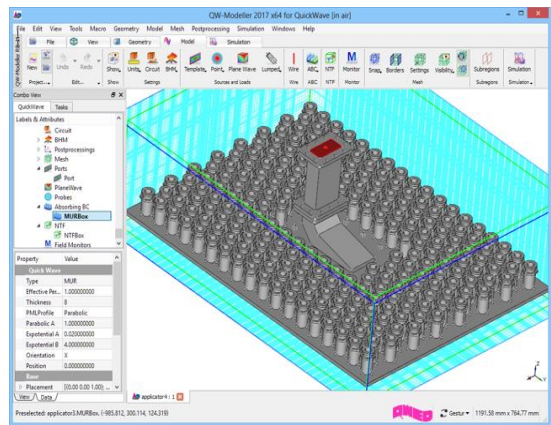

convenient CAD input

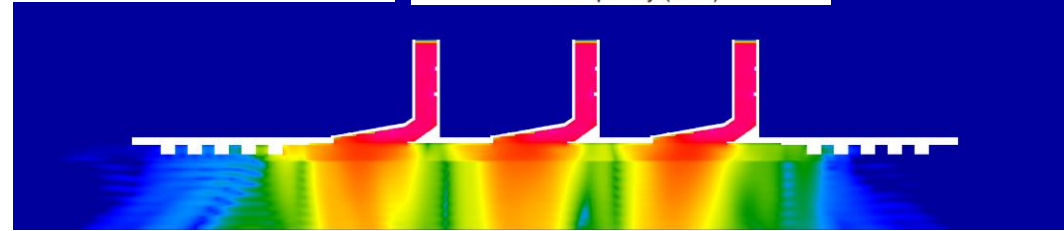
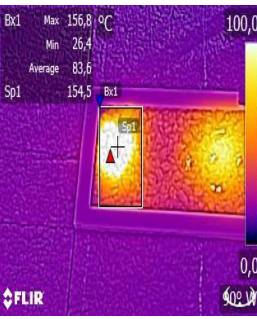
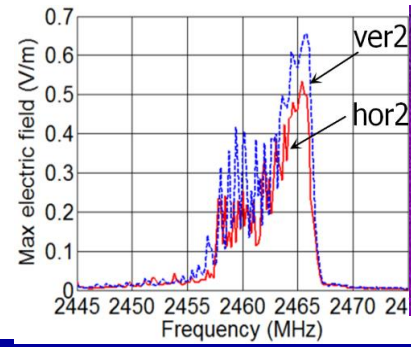
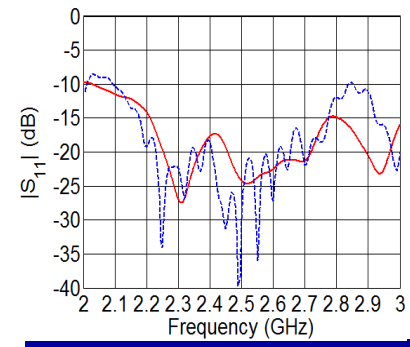

System of three MW power applicators with feeding system and leakage preventing chokes: designed, manufactured, tested

B.Salski et al., *IEEE MTT Trans.*, vol.65, Sep.2017.



Test-fixtures for precise material measurements

Split-post dielectric resonators for low-loss laminar dielectrics
subject of **European Standard IEC 61189-2-721:2015**
endorsed by Keysight Technologies Option 003 N1500A

Other commercially available TE01δ resonators

single-post
for resistive sheets

cavity
for liquides & powders

cavity
for bulk samples

Keysight Technologies
Split Post Dielectric Resonators for
Dielectric Measurements of Substrates

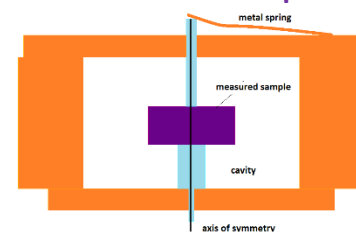
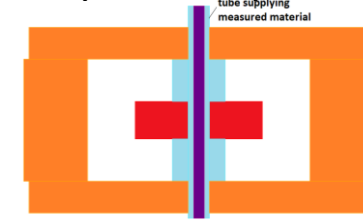
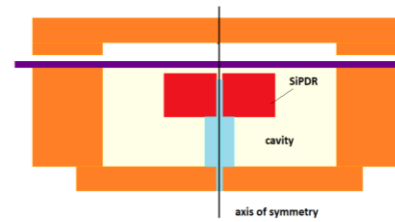
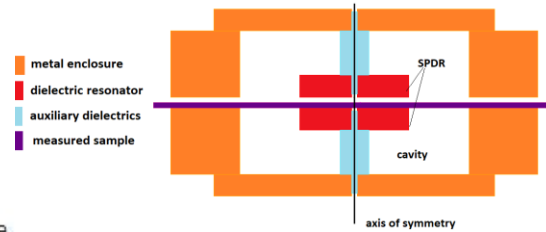

Application Note

Robust, easy-to-use with:

standard
VNA

QWED portable
low-cost Q-Meter

Recent SPDR-based designs for larger surfaces of:

large sheets of glass
manual scan @1.9 GHz

semiconductor wafers
automatic scan @10 GHz

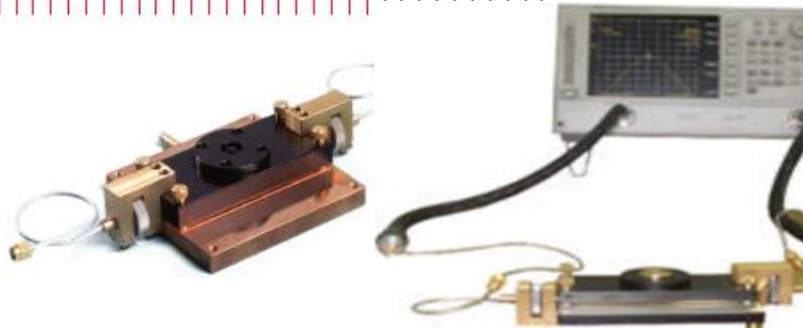

QWED standard SPDRs @ 1.1, 2.45, 5, 10, 15 GHz

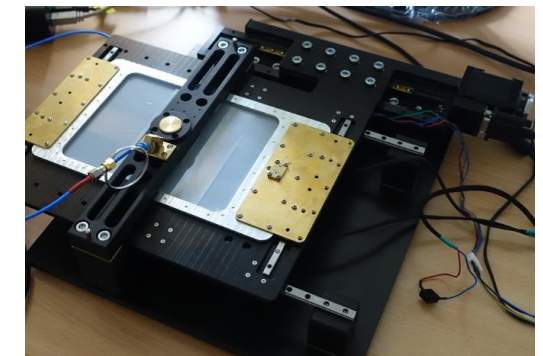
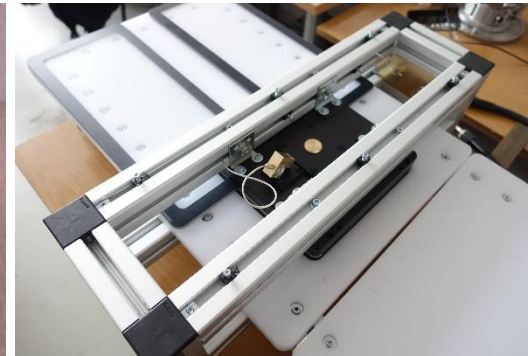
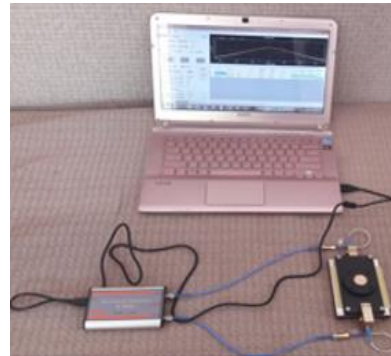

Ref.: www.qwed.eu

J. Krupka et al., *J. Eur. Ceramic Soc.*, vol. 21, pp. 2673-2676, 2001.

J. Krupka & J. Mazierska, *IEEE Trans. Instr. Meas.*, vol. 56, no. 5, 2007.

M. Celuch & al., *IEEE MTT-S IMS*, Boston 2019.

www.mmama.eu recent work under H2020-NMBP-07-2017 grant MMAMA No. 761036



Basic near-field workflow - insight into device performance

Unique, ultra-fast vector 2D Bessel & FDTD hybrid solver for design & analysis of devices with axial symmetry

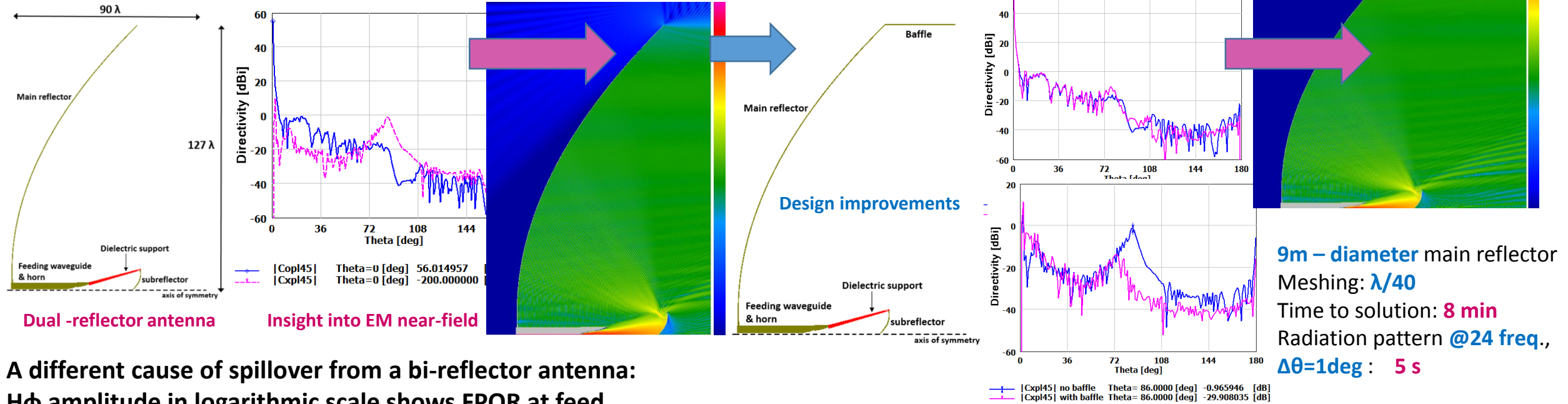

A different cause of spillover from a bi-reflector antenna:
H ϕ amplitude in logarithmic scale shows FPOR at feed
from max (purple) down to -60 dB (blue) at two freqs. within 3 %

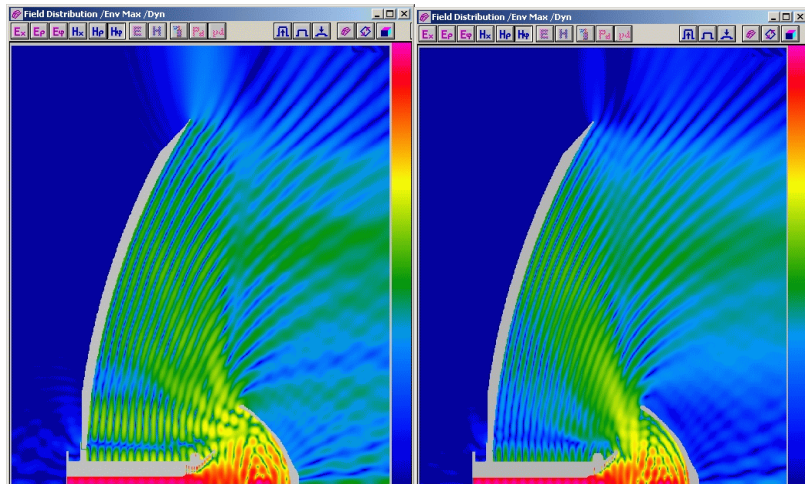

Gaussian beam formation for quasi-free-space material measurements
→ concept used for new Fabry Perot Open Resonator

BOR FDTD

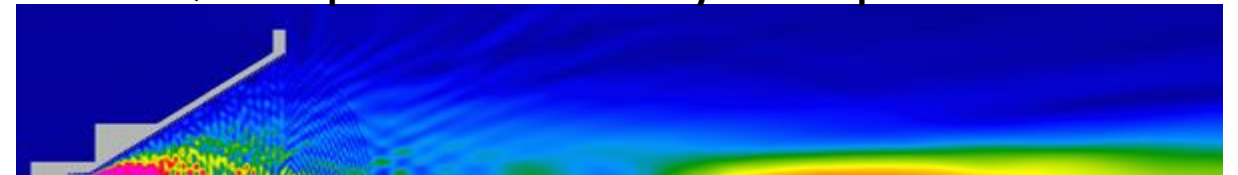

Scenarios modelled full-wave: 250 λ (in each dir.) modelled on average laptop
2500 λ on popular PC
5000 λ on top-shelf PC

Material parameters in EM analysis (1)



Various types of materials modelled by their macroscopic parameters – also frequency-dependent

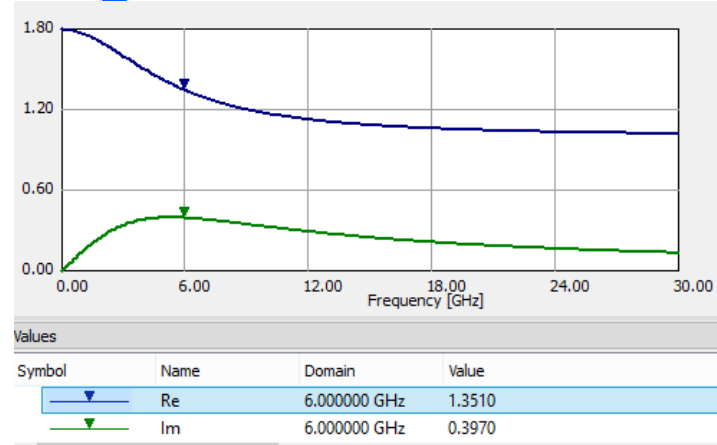
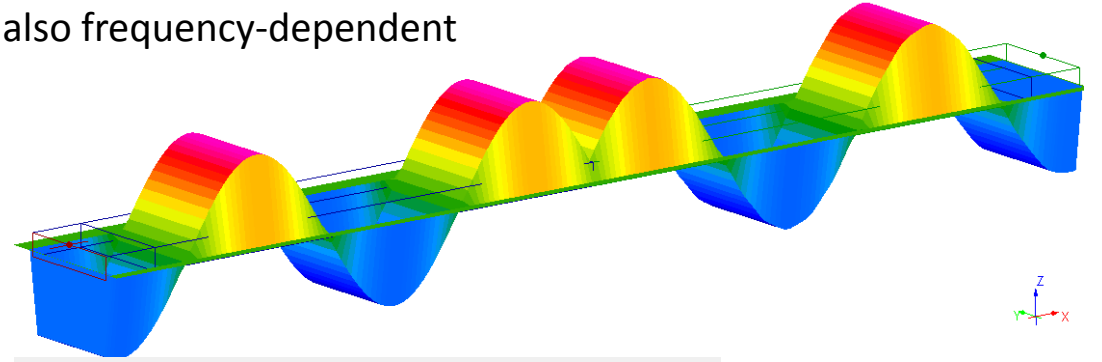
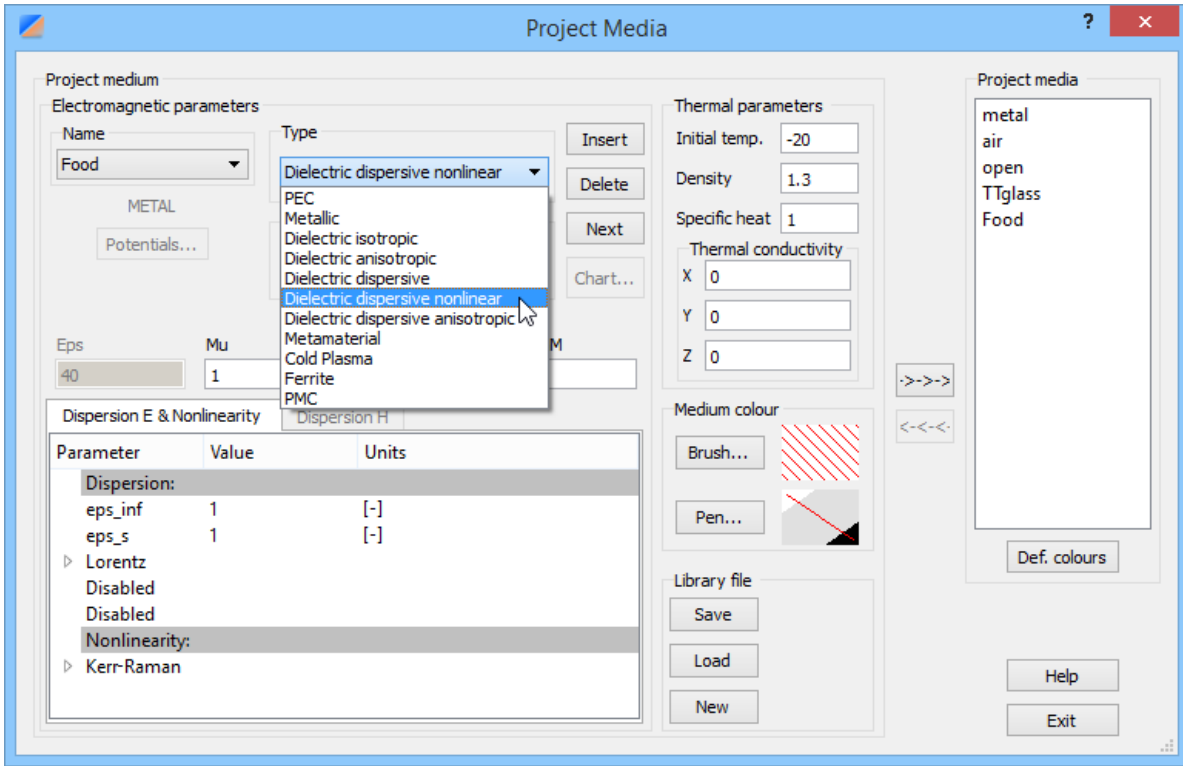

Arbitrary
Debye model
parameters
from QuickWave 3D

Drude:
$$\epsilon_r(\omega) = \epsilon_\infty + \frac{(2\pi f_p)^2}{(j\omega 2\pi v_c - \omega^2)}$$

Debye:
$$\epsilon_r(\omega) = \epsilon_\infty + \frac{\epsilon_s - \epsilon_\infty}{(1 + j\omega\tau)}$$

Lorentz:
$$\epsilon_r(\omega) = \epsilon_\infty + \frac{\epsilon_s - \epsilon_\infty (2\pi f_p)^2}{((2\pi f_p)^2 + j\omega 2\pi v_c - \omega^2)}$$

material parameters
from equations

Water parameters

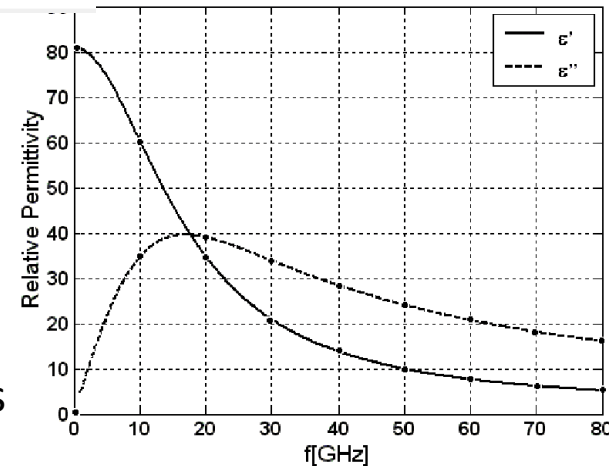

Bilateral coupling of various processes - EM-thermal workflow



material parameters
from user's text files
(private data base)

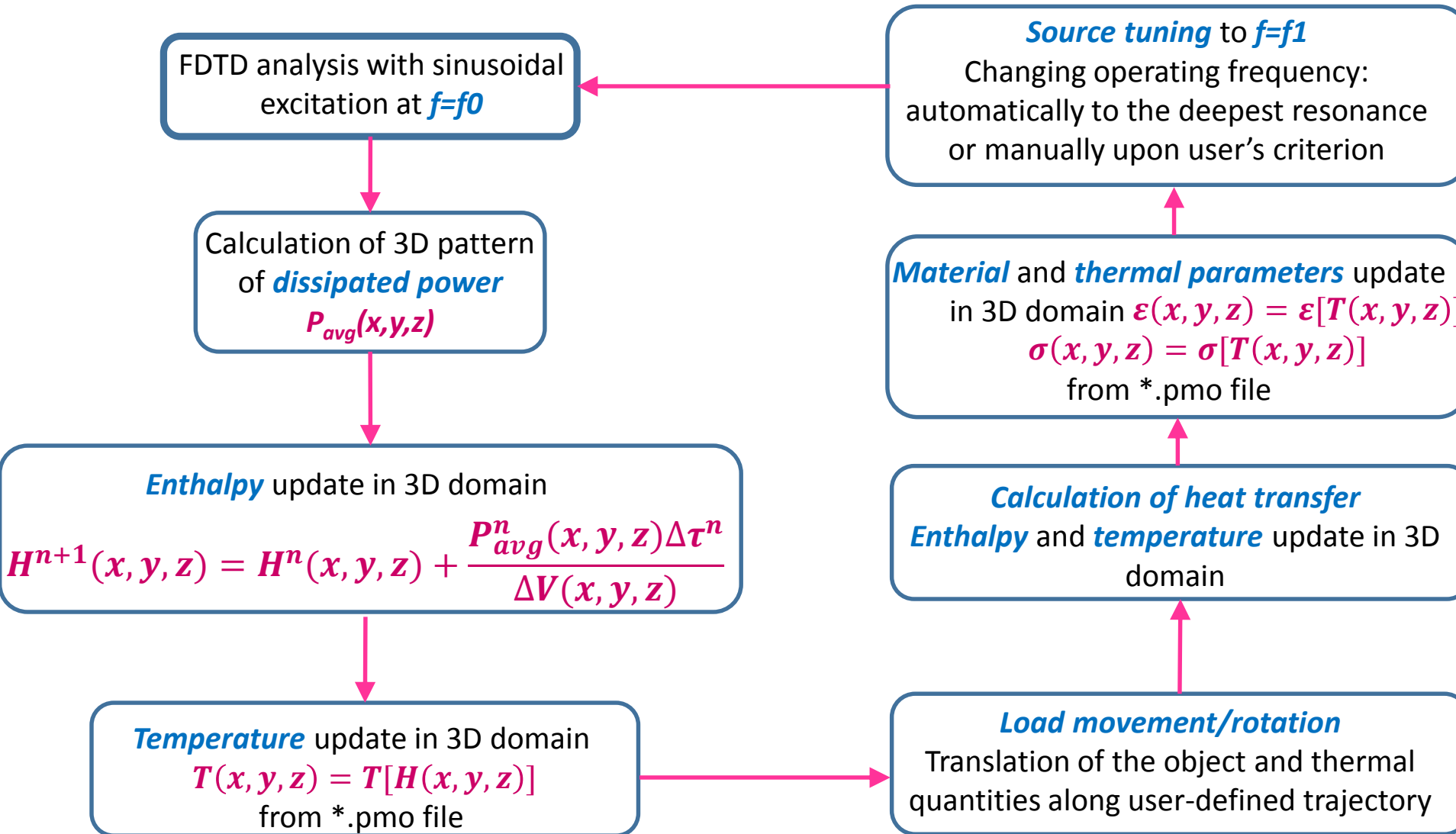

```

#Raw beef draft media file for QW-BHM module (00-09-06 POR)
#Measurements & refinements by Per O Risman, Microtrans AB, Sweden
#Modified by QMED, Poland
# DATA FROM -20 C to +80 C, dH/dV in J/cm3 reversedEnth/Temp column
!Temperature      Enthalpy      EPa      SIGa      SpecHeat Density  Ka
# Data deg C      J/cm3
-20                0                4.9       0.064     2.21     1.06     0.0069
-15               14.0             5.5       0.093     2.21     1.06     0.0069
-10               34.4             6.1       0.153     2.21     1.06     0.0069
-5                71.4            12.3      0.573     2.21     1.06     0.0069
-3               110.4            22.0      1.118     2.21     1.06     0.0069
-2.2             144.4            30         1.636     2.21     1.06     0.0069
-1.6             192.4            42         2.113     2.21     1.06     0.0069
-1.3             240.4            46         2.385     2.21     1.06     0.0069
-1.1             274.4            48.9       2.426     2.21     1.06     0.0069
-1.0             288.4            49.2       2.440     2.21     1.06     0.0069
10               327.9            48.9       2.317     2.21     1.06     0.0069
20               382.9            48.2       2.194     2.21     1.06     0.0069
35               450.4            46.9       2.072     2.21     1.06     0.0069
50               517.9            45.5       1.949     2.21     1.06     0.0069
65               585.4            43.6       1.922     2.21     1.06     0.0069
80               652.9            41.7       1.908     2.21     1.06     0.0069
  
```

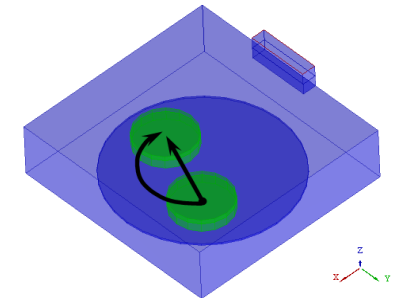

Multiphysics modelling: temperature-dependent materials

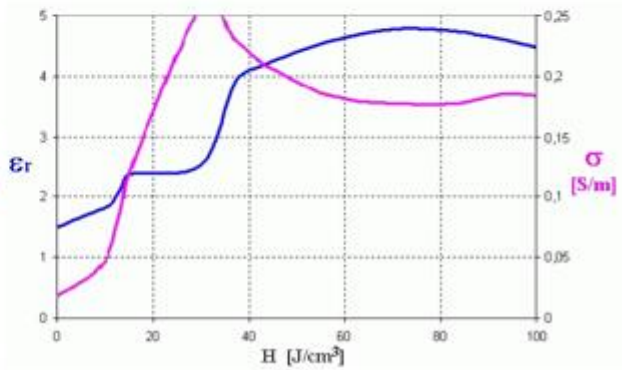
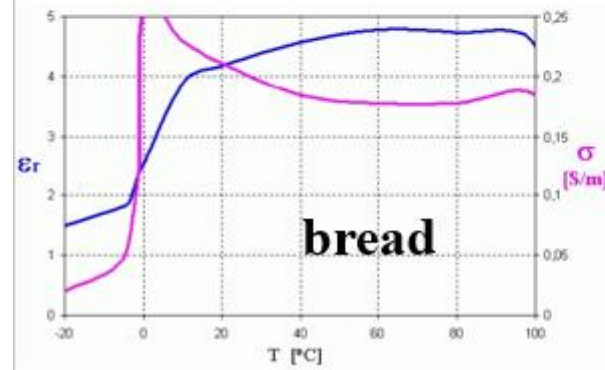
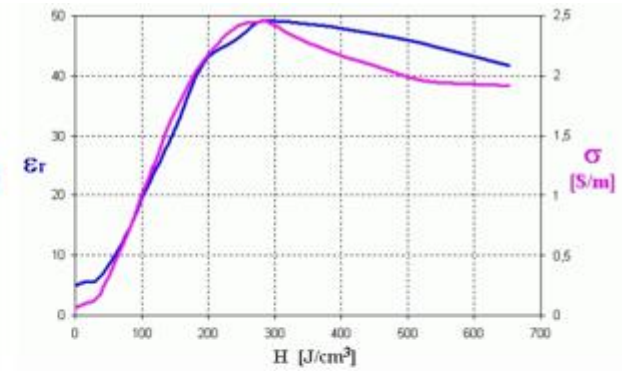
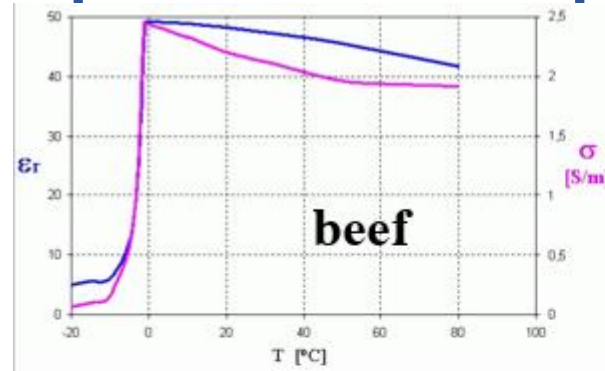
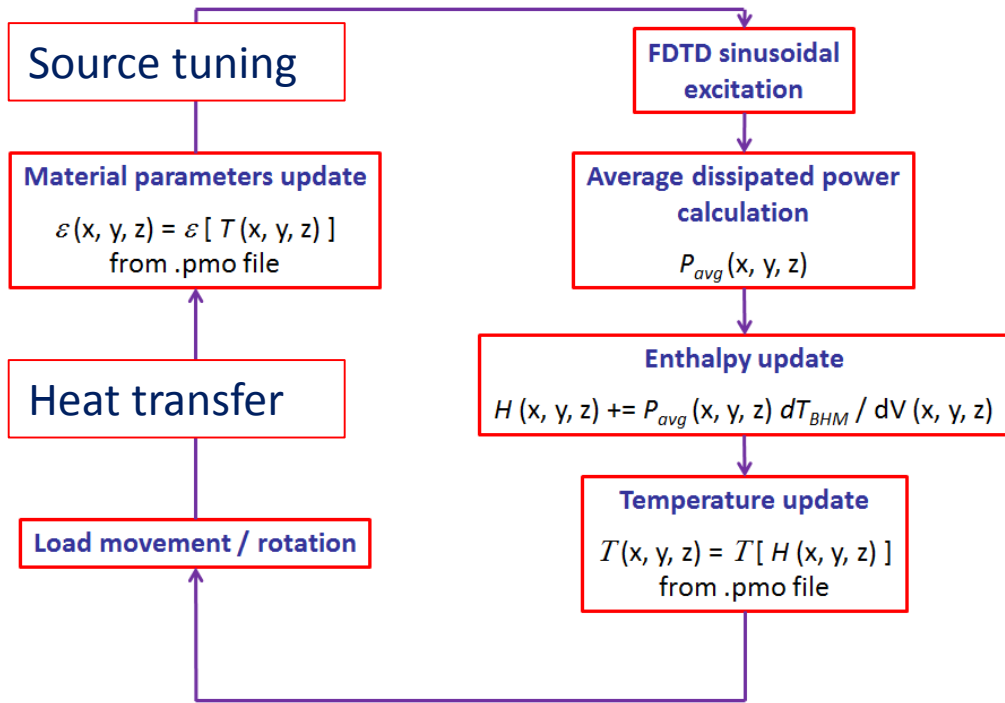

-20 deg.

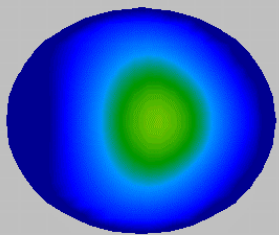

+20 deg.

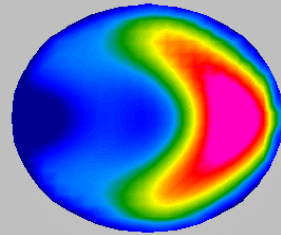

7 thermal steps

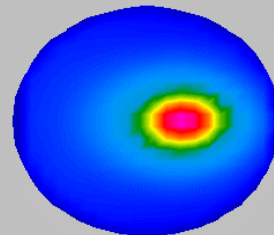

varying materials

- QW-BHM module of QuickWave:**
- **automatic** system
 - each cell heated individually
 - no need to define 1000s of "media"
 - **bilateral** coupling EM - thermal

QW-BHM coupled workflow and its impact on QWED customers

2000 - making users' life easier:

"I no longer need to *define 100 sausage media* to model one sausage!"

"It was and is particularly *helpful in the studies of the progress of defrosting* in microwave ovens, *assisting in the quantification (and experimental verification)* of the influences of the underheating (longitudinal section magnetic, LSM) modes between the cavity bottom and the shelf with food item.

This *has helped a lot in later developments of new oven models at Whirlpool.*

– It is also *helpful in studies of the edge overheating* effect, but then mainly in work with optimisation of geometries of containers and *quantifications of the influence of salt content* of e.g. sauces, then for *development of microwaveable ready meals.*

– Generally speaking, *use of the BHM module did a lot of experimental work obsolete,* and by that *saved both time and money in industry.* "

2019 – providing "freshly baked" functionalities to our users:

"*I attach the fresh paper!* As you can see, we have used both your subtraction option and the Austin man head (..)!"

Basic Heating Module → Block of Hybrid Modules

I believe in **coupling** (hybridisation) but it must be bilateral and...

...implemented with the adequate understanding of the physics!!!

QWED offers flexible interfaces
& seeks collaborations to "couple"

Accurate modelling of coupled electromagnetic-thermal problems

Verification & validation

Simple microwave heating benchmarks
& microwave heating phenomena studies*

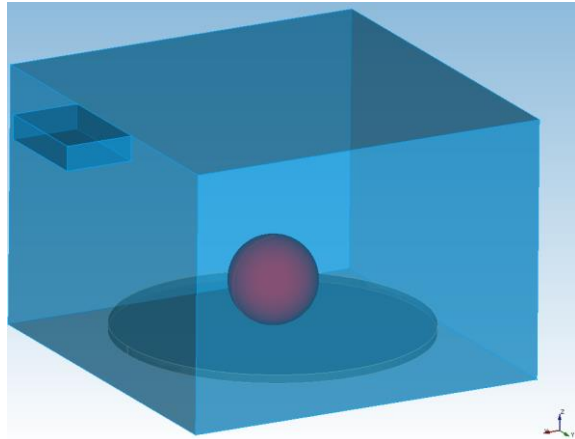

- heat transfer & load dynamics
- Load rotation & arbitrary movement during heating
- Source parameters tuning – regime for solid state sources
- Temperature dependence of material parameters

Freezing to file
the state of the
simulation

De-freezing on
arbitrary computer
& at convenient
time

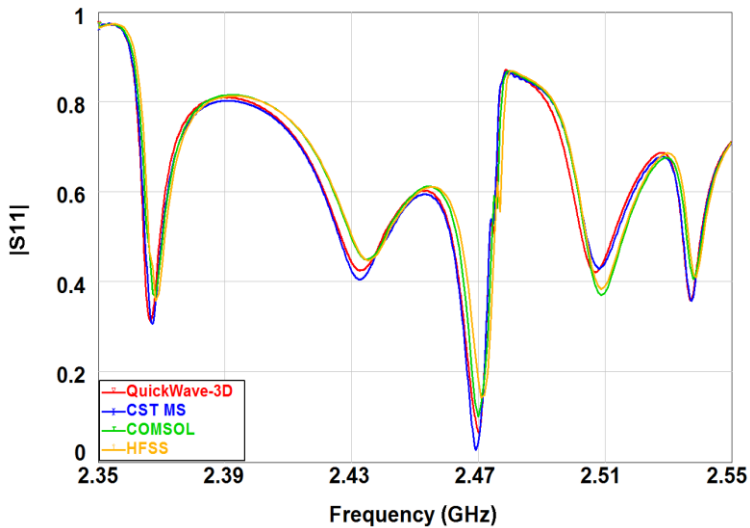

Design & analysis of real-life microwave oven cavities, incl.
complicated cavity shapes and advanced feeding system*

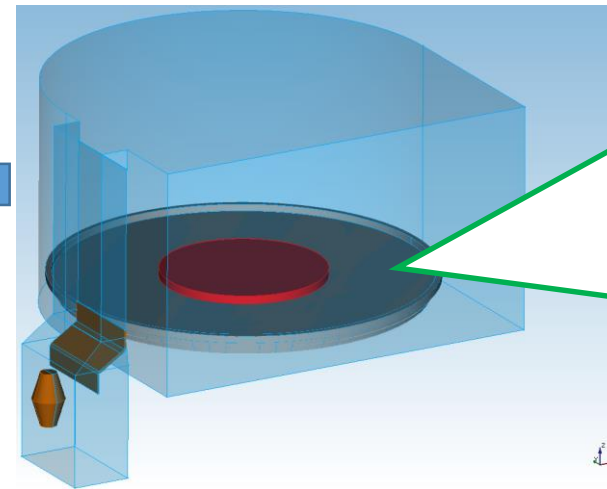

Courtesy of Whirlpool Inc. – Whirlpool MAX oven

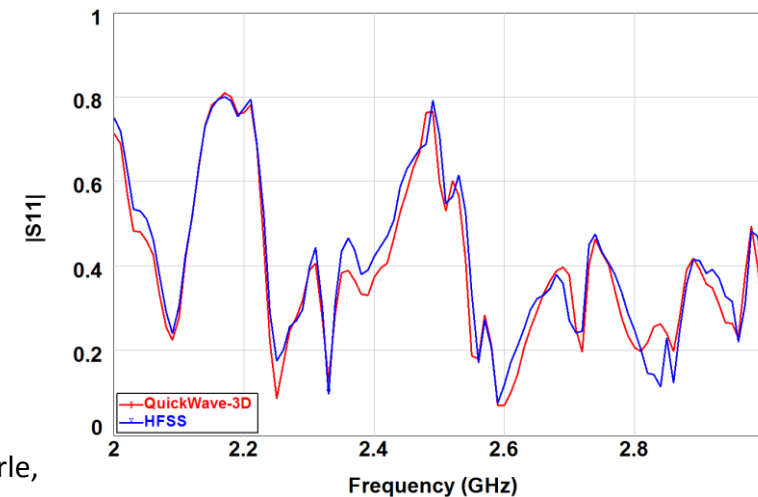
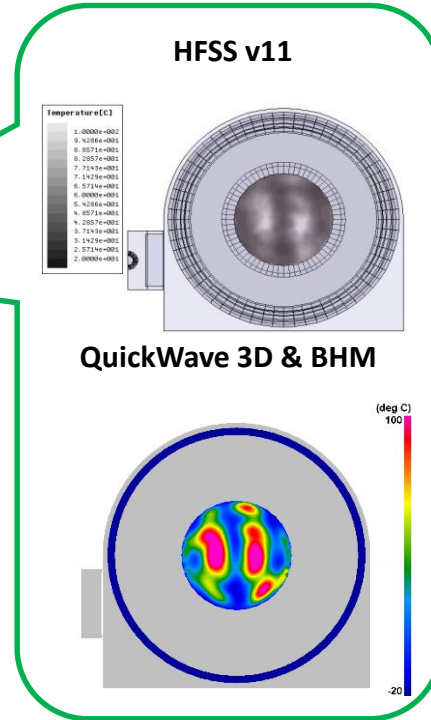

With QuickWave EM
computation as fast as
1 min 18s on a **low-cost
video card** – supporting
all graphic cards **with
OpenCL**

* Considered by M.Celuch, P.Kopyt & M. Olszewska-Placha in eds. M. Lorence, P. S. Pesheck, U. Erle, *Development of packaging and products for use in microwave ovens, 2nd Ed. Elsevier in print.*

Multiphysics modelling: *Collect Data* in *Grid Search* workflow

Collect Data of S11 and dissipated power density in potato heated in MW oven, as text files and GUI

Type	Name	Status
Results	S-Parameters Results	Window
	S-Parameters Cumulative Results	Cumulative Window
Radiation Pattern	Radiation Pattern Results	Window
	3D Radiation Pattern Results	Window
Fields	Fields	Window
	Fields	Window
Monitor	Monitor	Window

Open Windows at first run - suspend simulation at: last iteration

- Add
- Configure...
- Delete
- Clear
- S-Parameters Results
- S-Parameters Cumulative Results
- 2D Radiation Pattern Results
- 3D Radiation Pattern Results
- Fields
- Monitor

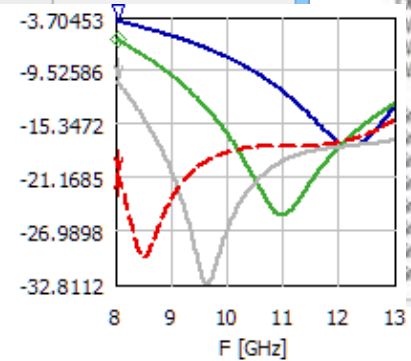

ϵ_r changing from 10 to 80

Grid Search Steps: 8, Iterations per Simulation=40000
 Number of Objectives: 1
 *Objective 1: Collect, WindowsNb=3
 Window 1: Fields, "Fields"
 Window 2: Fields, "Fields"
 Window 3: Fields, "Fields"

Grid Search=1: Variable(s): eps_potato=10-
 Grid Search=2: Variable(s): eps_potato=20
 Grid Search=3: Variable(s): eps_potato=30
 Grid Search=4: Variable(s): eps_potato=40
 Grid Search=5: Variable(s): eps_potato=50
 Grid Search=6: Variable(s): eps_potato=60
 Grid Search=7: Variable(s): eps_potato=70
 Grid Search=8: Variable(s): eps_potato=80+

Note: automatic multiple switching from pulse to sine excitation implemented in QuickWave for matching source to load.



Continuum modelling of thin conductive sheets

Thin conductive sheets in application to MW susceptors for enhancing food processing in domestic MW ovens

Thin conductive sheet



Measurements of Surface resistance

$$R_s = \frac{1}{\sigma h}$$

Simulation model



Single-post dielectric resonator

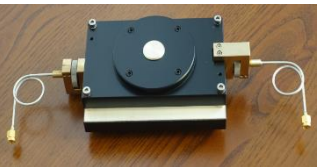

Split-post dielectric resonator

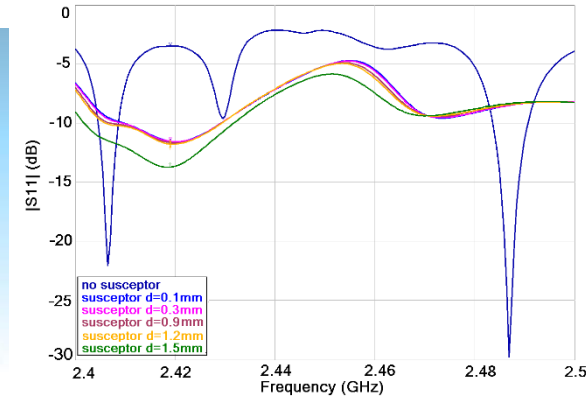
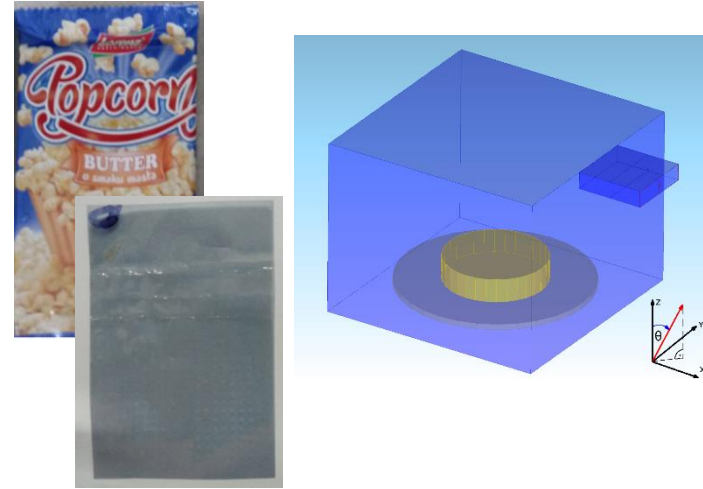

Thin sheets of carbon-based polymer composites described with surface resistance in $[\Omega/\square]$ in application to wideband MW absorbers

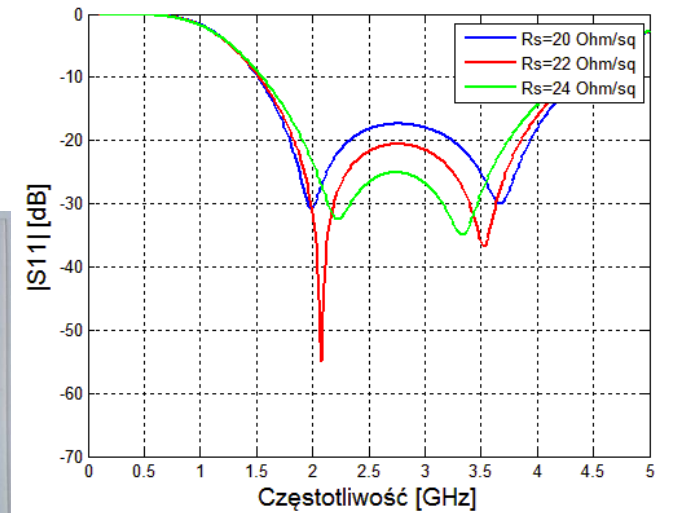
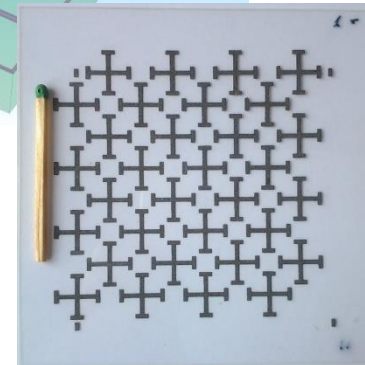
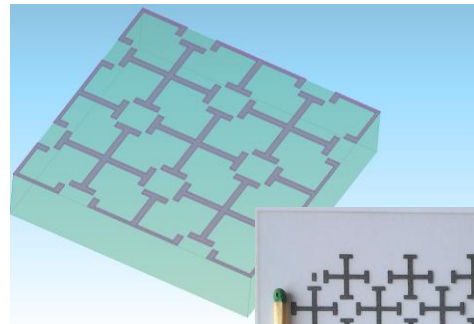

Efficiency of the modelling is enhanced by using pre-measured effective material parameters

Clever material modelling can reduce problem dimensionality!

Reduce 3D axisymmetrical problem (a) to planar 2D (b):

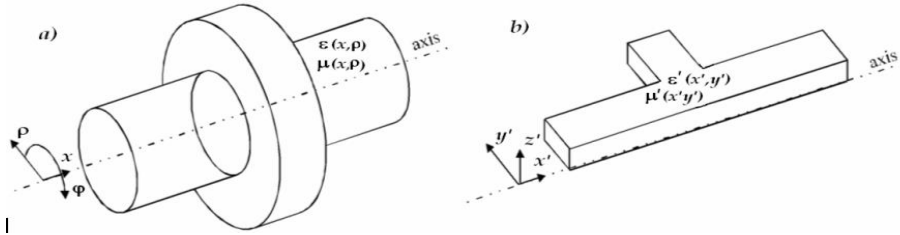

Apply Maxwell equations in cylindrical coordinates:

- numerical FDTD discretisation in 2D plane ($x\rho \rightarrow x'y'$)
 - economies in computer effort by 2-3 orders in magnitude
- angular $\cos(n\varphi) / \sin(n\varphi)$ field dependence enforced **analytically**
 - expected higher accuracy for high-n modes

Perforated coaxial cables

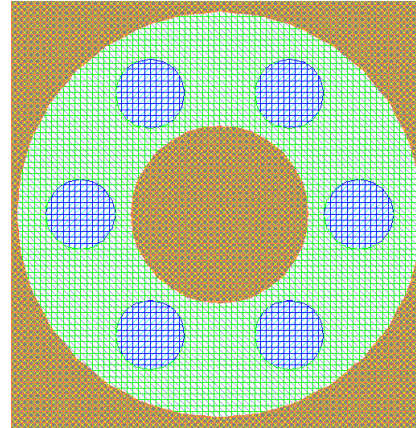

3D problems

- > reduce to 2D (long-section) with effective dielectric whose parameters are obtained by 2D quasistatic modelling of coax cross-section
- > efficiency enhanced by over an order in magnitude

"Since we have developed trust in QuickWave, we do not prototype any longer".

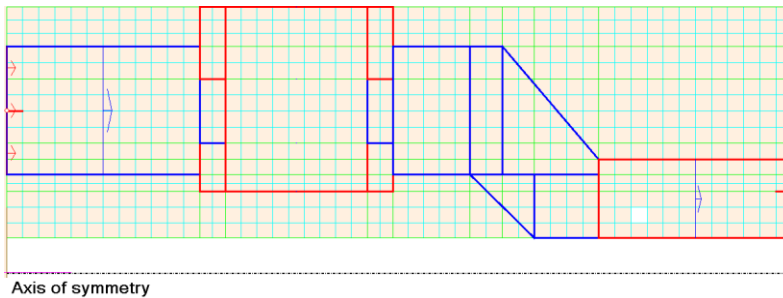
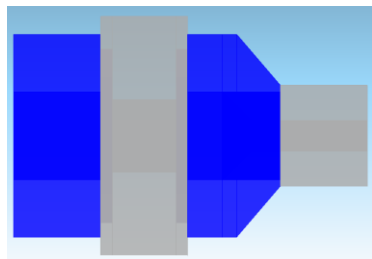
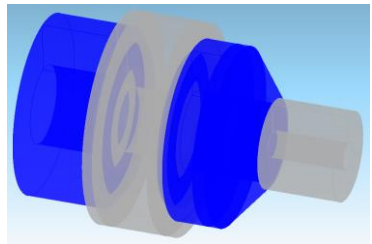

Similar modelling also used to design structural chiral new materials

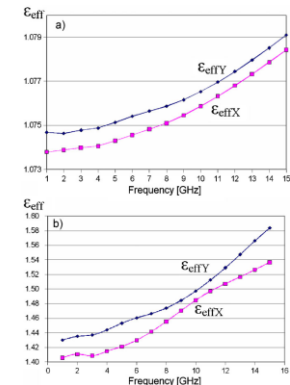
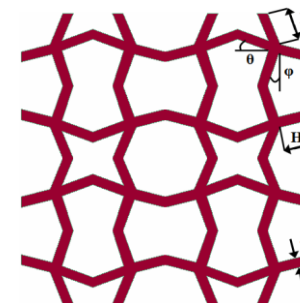

Following hardware breakthroughs

GPU and MultiGPU computations

Using **Open MP** standard to accelerate FDTD calculations and to separate fast FDTD calculations and graphics (simulation results' displays



All QuickWave functionalities included

Challenge: using **the right** programming platform:

CUDA

VS

OpenCL

Expensive professional computation nVidia cards

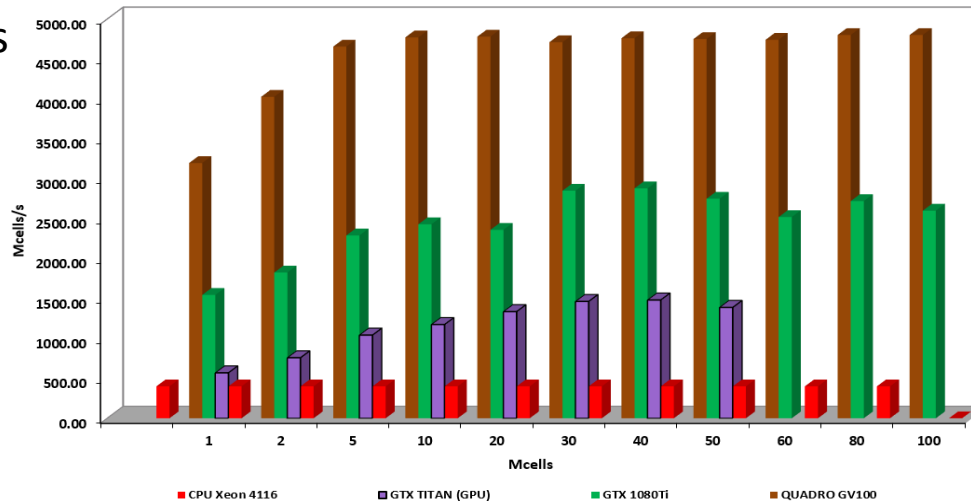

GPU acceleration of QuickWave 3D

Time to solution decreased even **10 times** comparing to powerful CPUs

Also low cost video cards (with good performance parameters) of different manufacturers

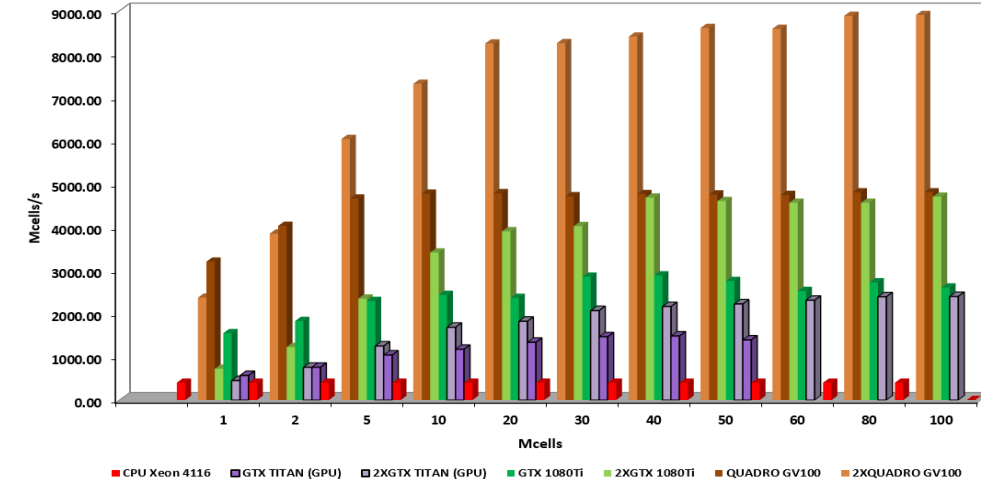

MultiGPU acceleration of QuickWave 3D

Time to solution decreased even **18 times** comparing to powerful CPUs (**..but only 1-2% of users...**)

Modelling **workflow** for validation of SPDR method assumptions

How much is the E-field pattern influenced by SUT?

→ application of "**near field imaging**" in QuickWave

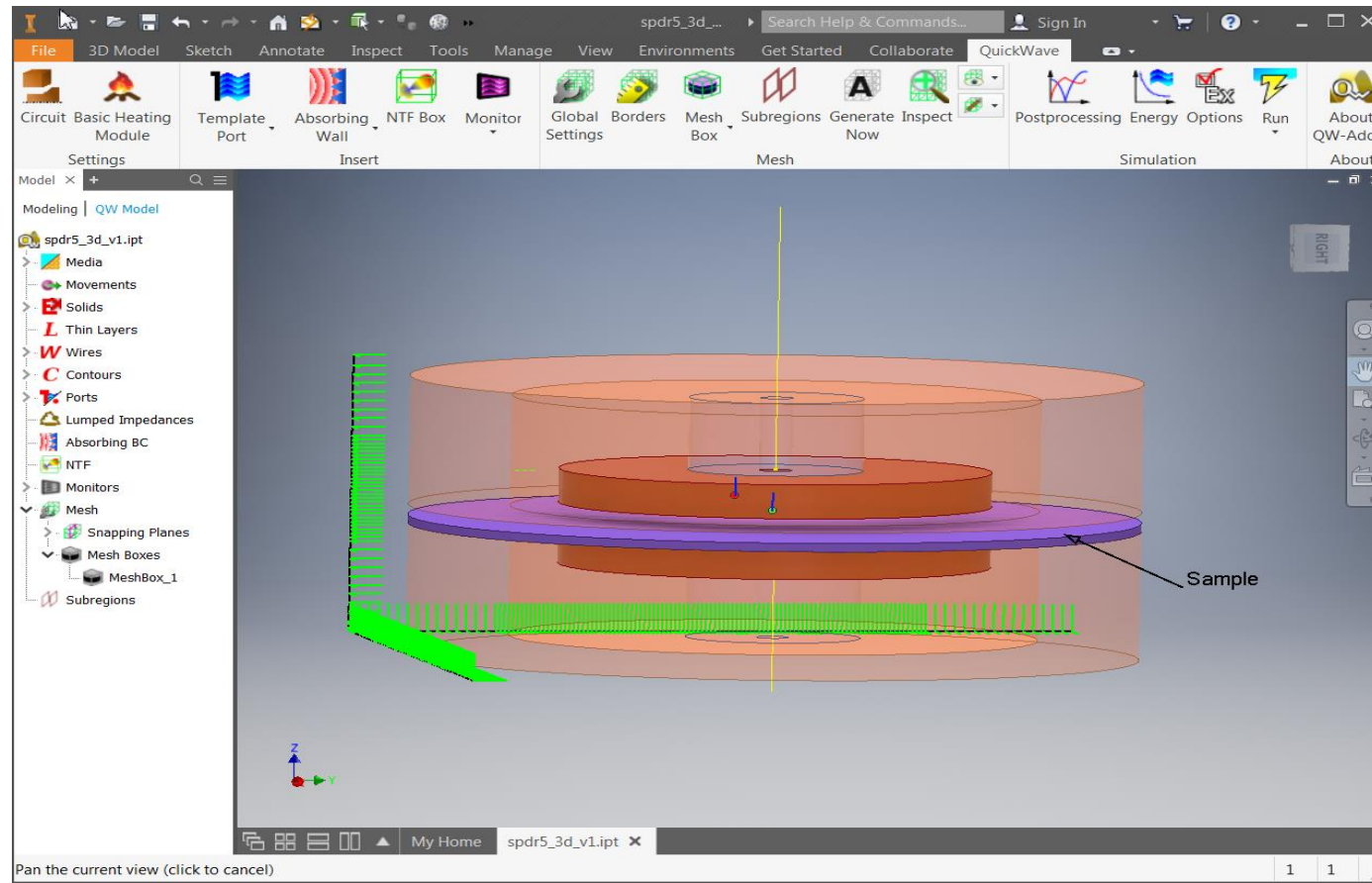

10 GHz SPDR model in **QW-AddIn** for Autodesk® Inventor® Software

Modeling workflow for validation of SPDR method assumptions

How much is the E-field pattern influenced by SUT?

→ application of "*near field imaging*" in QuickWave

empty

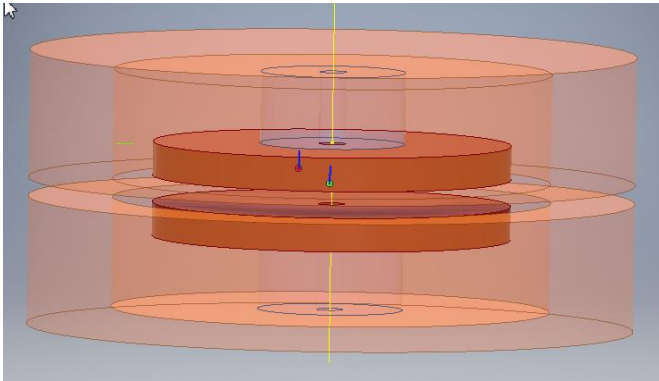

with SUT

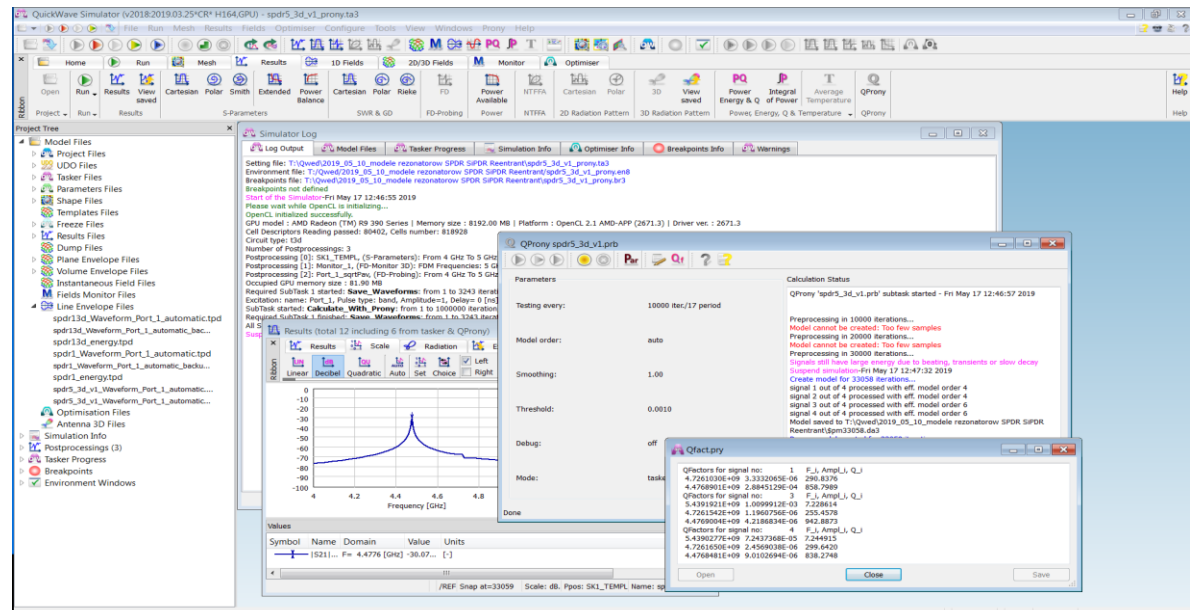
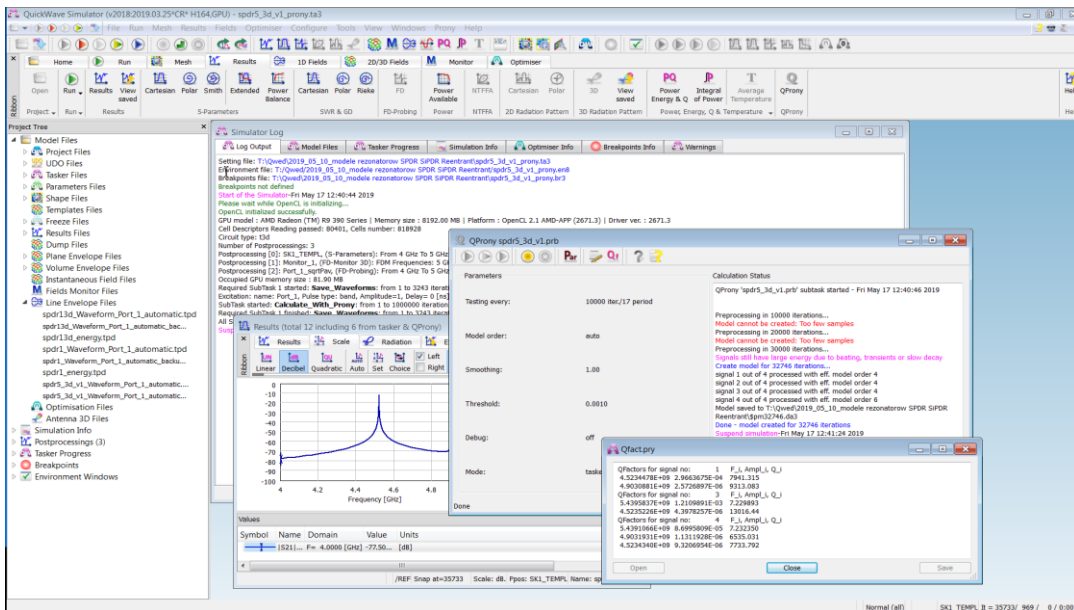
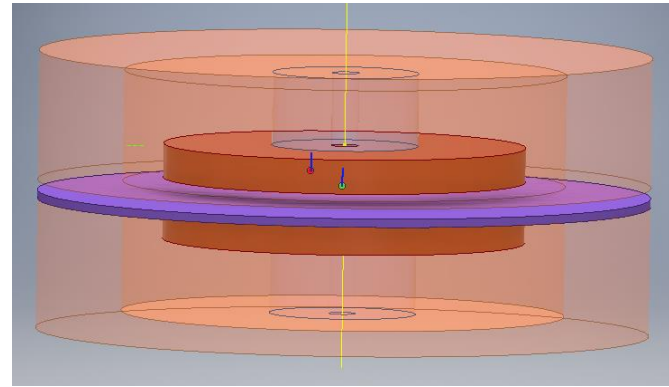

Modelling validation of SPDR method assumptions

How much is the E-field pattern influenced by SUT?

→ application of "*near field imaging*" in QuickWave

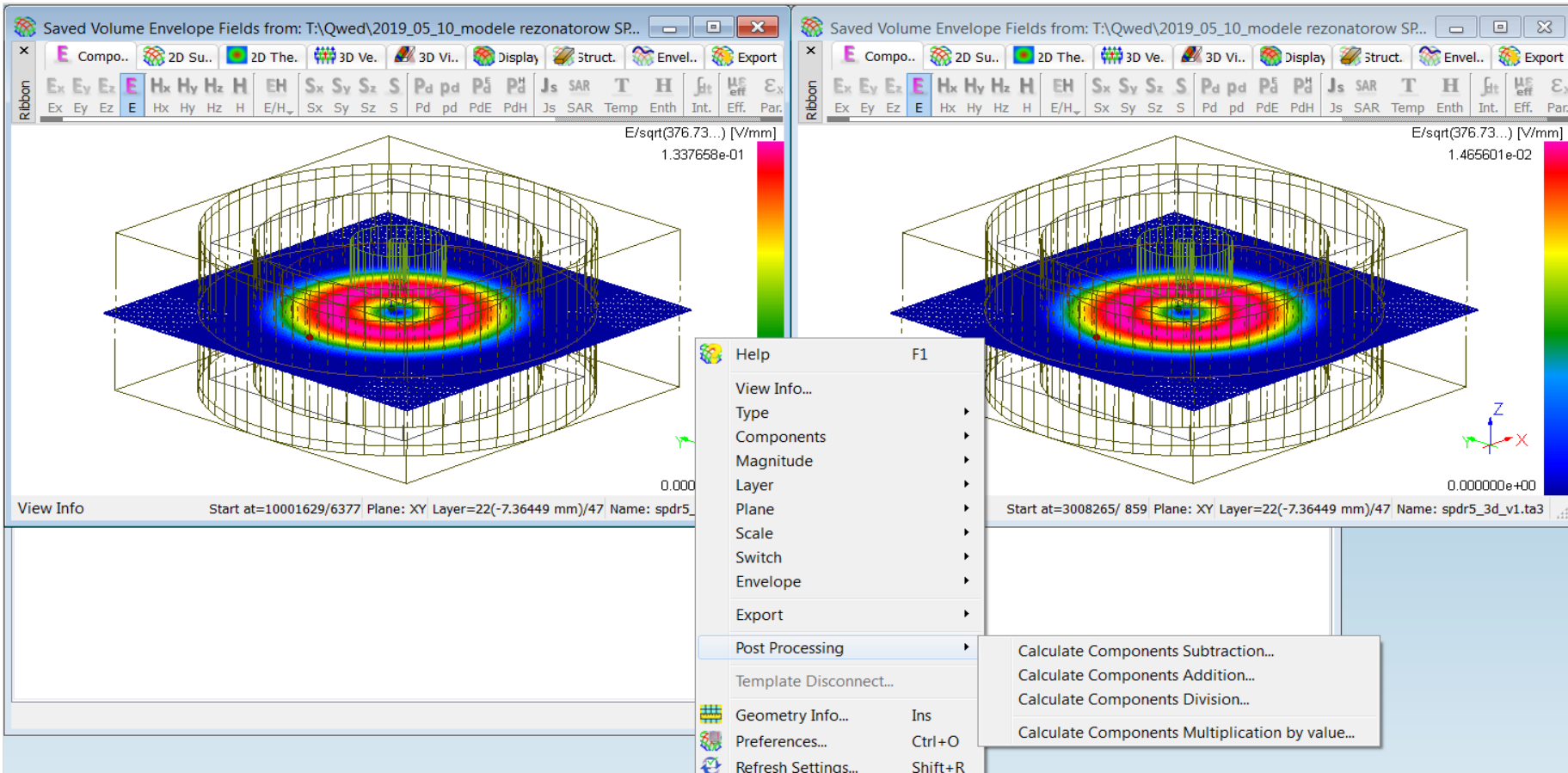

field subtraction
workflow

two linked models

Currently field subtraction performed on saved fields.
Parallel running of 2 scenarios under development.

Modelling validation of SPDR method assumptions

How much is the E-field pattern influenced by SUT?

→ application of "*near field imaging*" in QuickWave

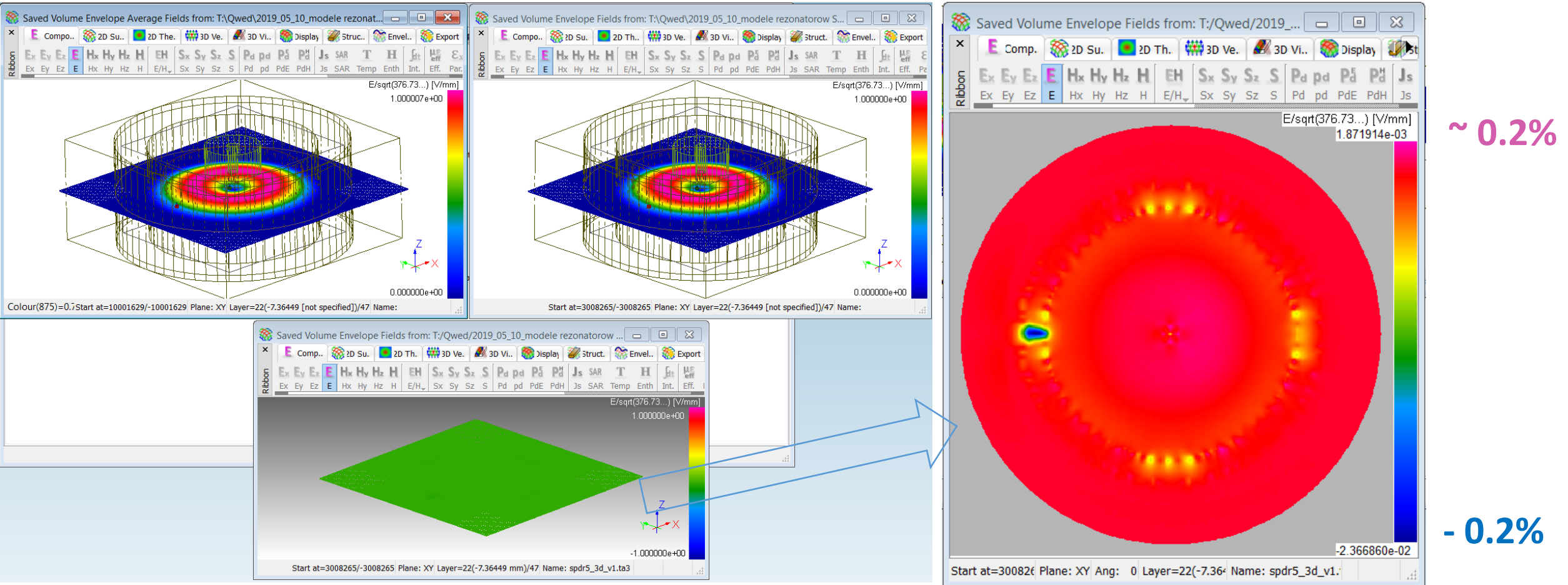

Advanced (linked) near-field imaging workflow

Separation of incident and diffracted fields (*option implemented per request of P.O.Risman, Malardalen Univesity*)

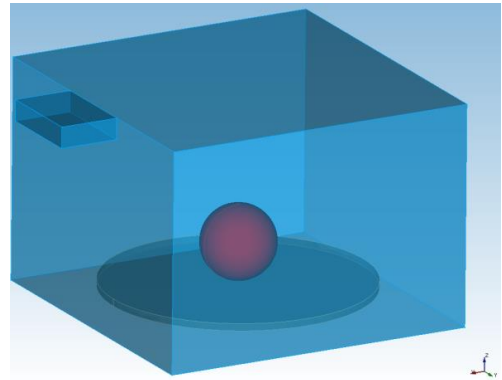

E-field in an empty cavity

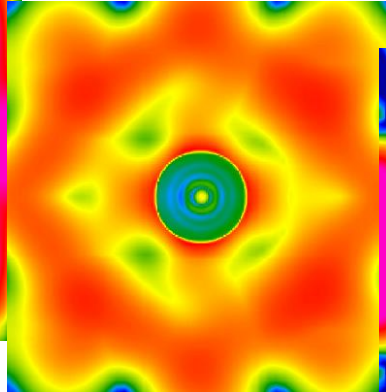
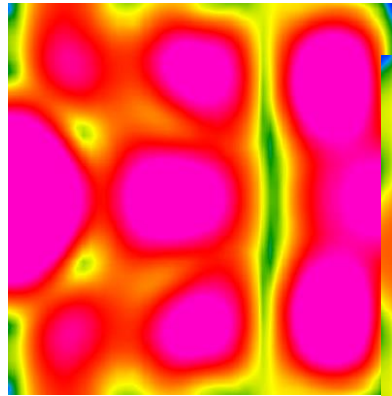

E-field in a loaded cavity

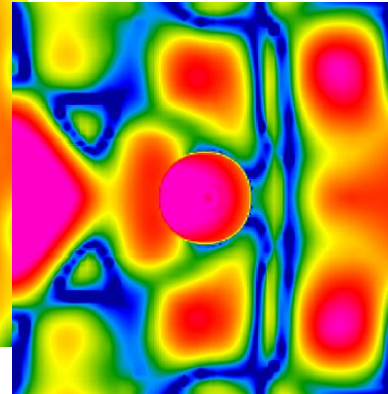

Scattered near-field in cavity

Detection of inhomogenities in tissues

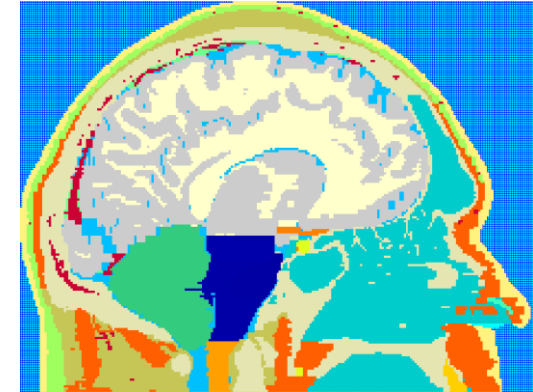

AustinMan model* converted to QuickWave EM software for Mälardalen University, Sweden

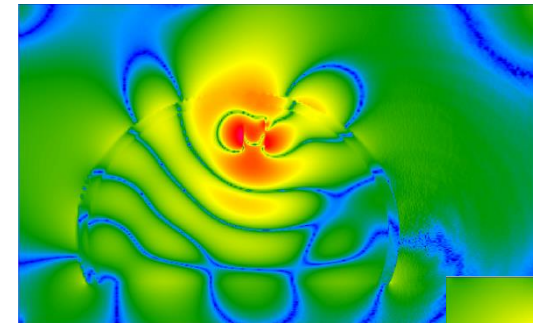

- ✓ **Tumours & haemorrhages detection**
- ✓ **Optimisation of multiantenna tomographic systems**

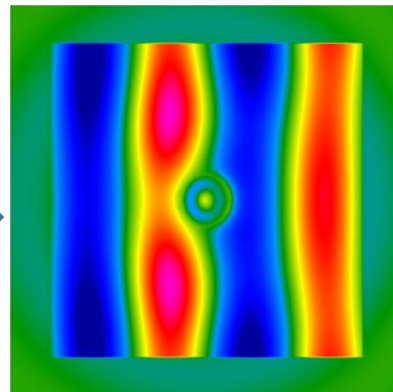
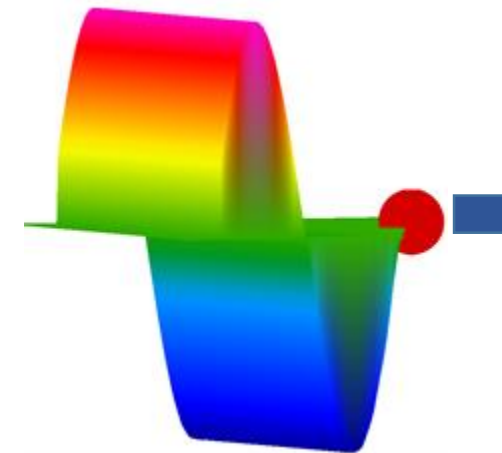
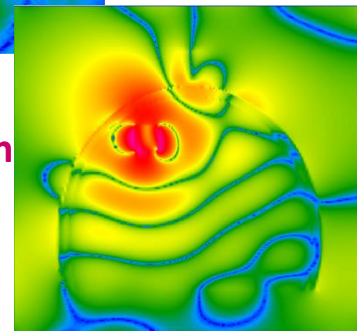

Total field
Focusing by the load
„exploding egg effect”

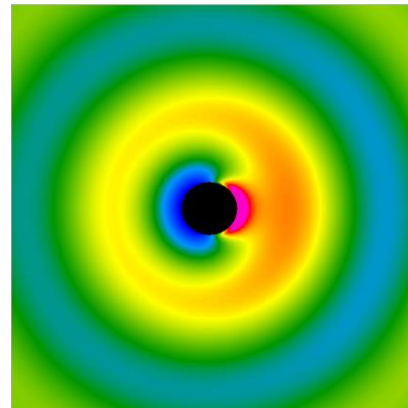

Diffracted field reveals
cause of focusing:
circumferential resonance

EMMC Turin 2019

* <https://sites.utexas.edu/austinmanaustinwomanmodels/>

Dedicated user interfaces for parametrised project creation

QW-Editor

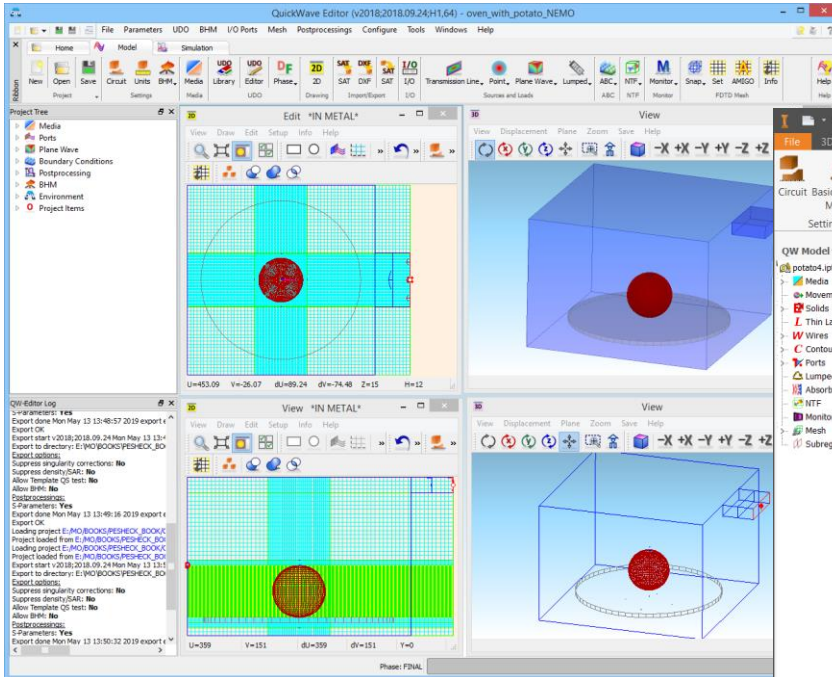

In-house, script based

Import/export to *.sat & *.dxf

QW-AddIn for Autodesk Inventor Software

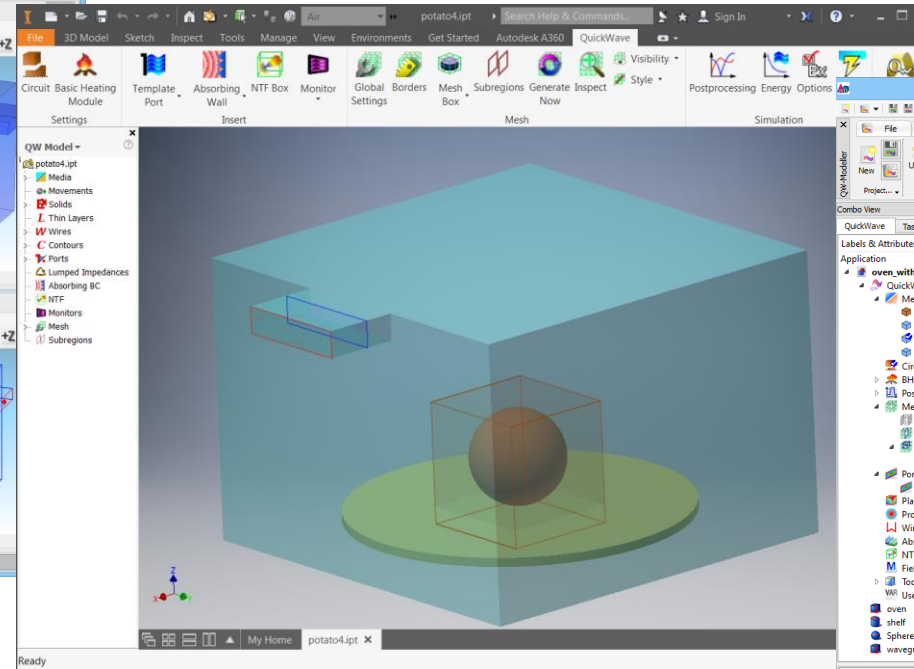

Based on advanced professional CAD tool

Import/export to e.g. *.sat & *.step

QW-Modeller NEW BUSINESS MODEL

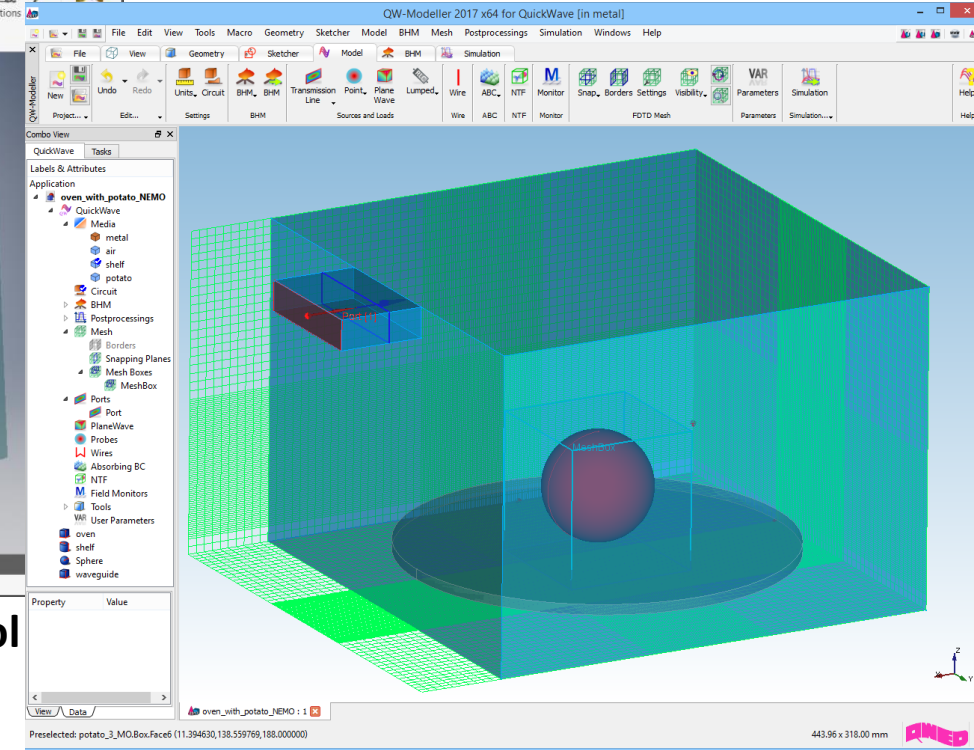

CAD tool - FreeCAD based

Free of charge, No licences, No time restrictions, No project limitations

Import/export to e.g. *.step, *.iges & *.dxf

Curiosity: export of CAD files from "old" QW-Editor for further manufacturing is reported by our user.

Conclusions: on software development & business

- EM modelling is a powerful tool for MW design, also for development of new materials & material measurement methods.
- EM modelling workflows help bridging the gaps between seemingly different technology domains:
 - *near field imaging* explains exploding eggs *but also* helps in material measurements,
 - *Brewster angle* is exploited in telecommunications *but also* in domestic MW ovens.
- Modelling lies at the basis of material measurements,
- ...but modelling itself is only as good as the previously measured material parameters
- ...and modelling use used to design materials.
- Two approaches to commercial software development:
 - *black box* that quickly provides *solutions = numbers*,
 - *virtual laboratory* that provides *physical insight*, but *users' preferences vary...*
- It is possible to set up a business based on a research idea (no initial funding or other forms of support).
- The price to pay for setting up a business is not just financial; it involves change of lifestyle and vast responsibility.
- But a "gem" does not shine forever... QWED business continues with licences/consulting/hardware/R&D projects.
- QW-Modeller & short-term solver licences also form a new business model.
- I believe in coupling but only if well understood in terms of the underlying physics & different scales.
- QWED seeks collaborations & individual enthusiasts.

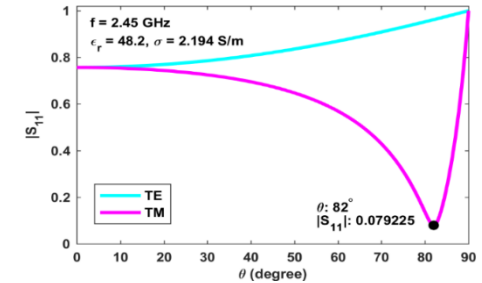

THANK YOU!