

SDN/NFV 5G Fronthaul Networks Integrating Analog/Digital RoF, Optical Beamforming, Power over Fiber and Optical SDM Technologies

Raul Muñoz, Josep M. Fàbrega, R. Vilalta, R. Casellas, L. Nadal, R. Martínez, M. Svaluto Moreolo
 Centre Tecnològic de Telecomunicacions de Catalunya
 (CTTC/CERCA), Castelldefels (Barcelona), Spain
 {raul.munoz, jmfabrega}@cttc.es

Marco Capitani, Giada Landi
 Nextworks
 Via Livornese 1027,
 Pisa, Italy
 {g.land, m.capitani}@nextworks.it

Simon Rommel, Idelfonso Tafur Monroy
 Institute for Photonic Integration
 Eindhoven University of Technology
 5612AE Eindhoven, Netherlands

Gabriel Otero, Juan Dayron López, Carmen Vázquez,
 David Larrabeiti, David Sánchez
 Universidad Carlos III de Madrid (UC3M),
 Madrid, Spain

Evangelos Grivas
 Eulambia Advanced Technologies
 Athens, Greece
 vage@eulambia.com

Abstract—This paper presents the novel SDN/NFV 5G fronthaul network scenarios deployed in the blueSPACE project. blueSPACE envisions the upgrade of the fronthaul network to include optical SDM transmission for further increasing the network capacity. One of the novelties is the introduction of ARoF transceivers to reduce the 5G fronthaul bandwidth requirements, in addition to the DRoF solutions that are used for the 4G fronthaul interface and the 3GPP’s NGFI. Moreover, ARoF transceivers enable to develop optical beamforming technologies for beam steering and multi-beam transmission. Finally, power of fiber solutions to remotely feed small cells are also considered.

Keywords—SDN, NFV, ARoF, DRoF, OBFN, SDM, PoF

I. INTRODUCTION

Spatial Division Multiplexing (SDM) is the key technology to overcome the capacity requirements for the 5G fronthaul transport between the remote radio heads (RRHs) and the base band units (BBUs) [1]. The simplest way to develop SDM is making use of the already deployed bundles of single mode fibers. However, the main target is exploiting the spatial dimension of the multi-core optical fibers.

Radio over fiber (DRoF) transceivers based on Wavelength division multiplexing (WDM) have been used to transport the 4G fronthaul interface (common public radio interface –CPRI), as well as the next generation fronthaul interface (NGFI) defined by the 3GPP to reduce the 5G bandwidth requirements. The blueSPACE project proposes an alternative solution to reduce the bandwidth and latency requirements based on analog radio over fibre (ARoF) transceivers, where the radio waveforms are directly modulated onto light for connecting BBUs and RRHs.

Additionally, ARoF also enable the deployment of an optical beamforming network (OBFN) in combination with SDM technology for parallel propagation within the same fiber, as investigated in blueSPACE. OBFN enables to deploy RRHs with multiple beams that can be dynamically steered. Finally, although power over fiber is at very early development stage, the interest of this technology for 5G is big given the high costs of deployment of base stations in areas where no power supply is easily available. blueSPACE is addressing the usage of multi-core fibers to feed the small cells.

This paper presents four integrated SDN/NFV 5G fronthaul scenarios considered in blueSPACE project for validation and testing, describing the configurable hardware parameters and SDN/NFV control functionalities to provide network services.

II. AROF FRONTHAUL SCENARIO

A. Integrated test scenario

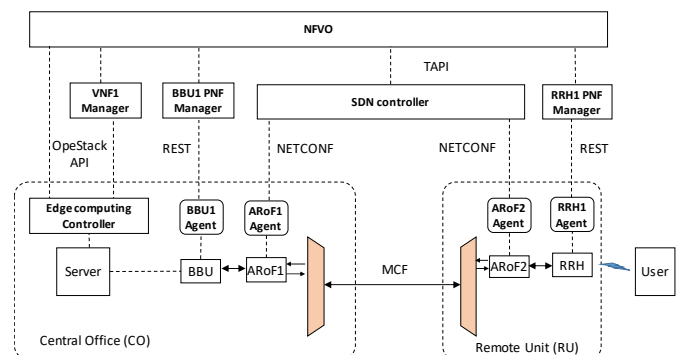

Fig.1: SDN/NFV ARoF fronthaul scenario

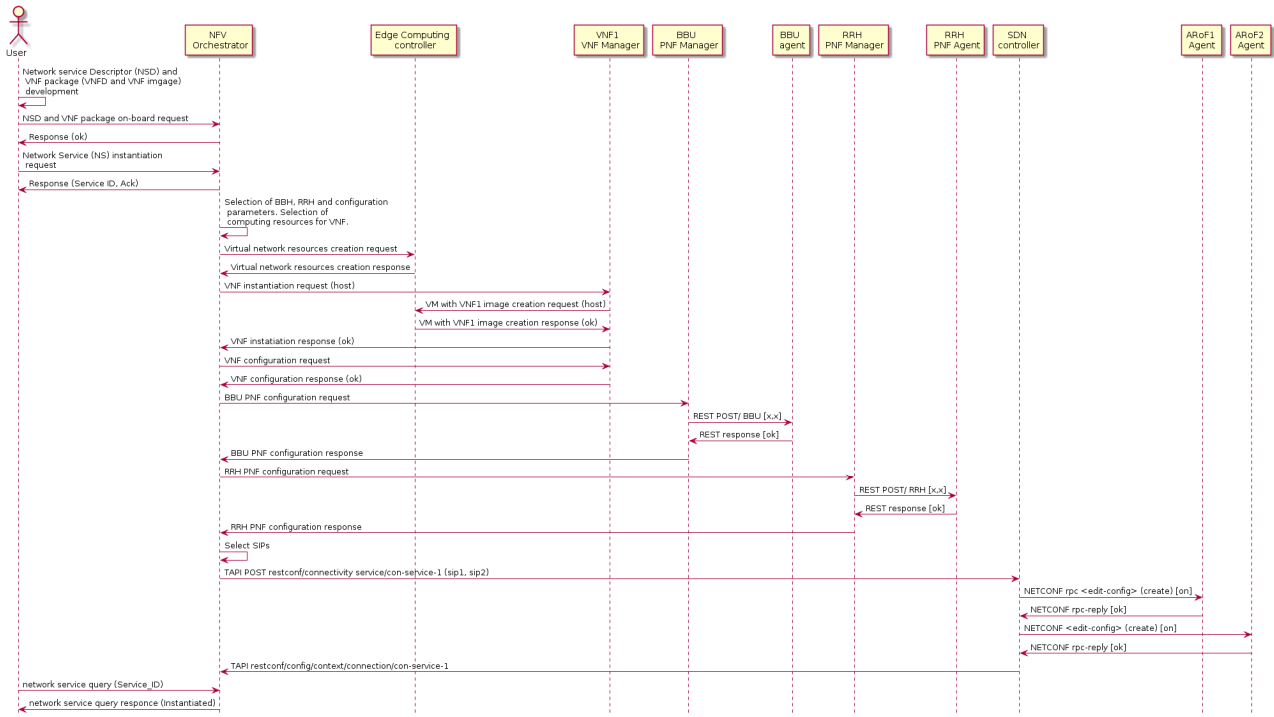

Fig.2: SDN/NFV MANO workflow for service provisioning in the ARoF scenario

ARoF fronthaul (Fig.1) has gained significant interest as an efficient alternative to more traditional digital radio-over-fiber, as it minimizes the use of bandwidth, eliminates the need for digitization of the radio frequency (RF) signal at the remote site and combines maximum centralization of resources with minimum latency [1]. The analog transport of the radio frequency (RF) or an intermediate frequency (IF) signal to the remote site, simplifies the radio remote head (RRH) to only include upconversion (in the case of IF-over-fiber (IFoF) fronthaul), power amplification and radiation elements – with the optional addition of beamforming either in the electronic or optical domain (as further discussed in section III). In the central office (CO) on the other hand, signal processing becomes a little more involved, as not only is the entire processing across all layers centralized, but also conversion of the digitally generated signal to an analog signal and adaptation of this signal optical transport must be handled [1].

In the ARoF fronthaul scenario introduced here, IFoF transport with optical heterodyning at the remote unit (RU) is employed for fronthaul and upconversion to millimeter wave (mm-wave). Thus, in addition to the typical signal generation and processing functions, the ARoF BBU further handles digital to analog conversion and modulation onto an IF carrier for the signal to be sent towards the end users, as well as the opposite process for signals received from the end users. The generated analog IF signal (in the case of blueSPACE at frequencies f_F between 2.25 GHz and 5.5 GHz) is modulated onto one of a pair of optical carriers spaced at $f_{LO} = 22$ GHz generated by the ARoF transceiver. A multi-core fiber (MCF) allows multiplexing of multiple IFoF signals for joint transport to the remote radio head (RRH), where the signal is received by a second ARoF transceiver and the beating of the two optical tones on the optical receiver directly generates the desired mm-wave RF signal at frequencies between 24.25 GHz and 27.5 GHz (i.e., $f_F + f_{LO}$) and

hence in the n258 band assigned for mm-wave 5G NR communications in Europe [2]. After amplification, the signal is radiated to the end user, where it is received, downconverted and processed accordingly. In the opposite direction, the RF signal received from the end user is downconverted electrically to the same IF range and transported back to the CO for processing using the same IFoF fronthaul scheme.

The ARoF fronthaul scenario implements a full NFV/SDN control plane that integrates an NFV service platform, extended with dedicated Virtual Network Function Manager (VNFM) and Physical Network Function (PNF) Managers (PNFMs), with an SDN Controller operating over the optical network. The NFV Service platform is composed of the NFV Orchestrator (NFVO) and the Edge Computing Controller. The NFVO manages the overall lifecycle of the Network Services (NSs). Its prototype implements an internal information model and external REST APIs compliant with the ETSI NFV IFA specification and provides enhanced features for the management of PNFs and the automated setup of optical paths, activated through the SDN controller. The Edge Controller, based on OpenStack, acts as Virtual Infrastructure Manager (VIM), allocating Virtual Machines (VMs) and virtual networks at CO. The NFVO coordinates the configuration of both VNFs and PNFs through the VNFM and PNFM. The interaction with PNF equipment like RRHs and BBUs is mediated through the associated PNF Agents, which translate standard messages from the PNF into hardware-specific protocol messages.

The control of the network interconnecting CO and RU components is delegated to the SDN controller, but still under the global coordination of the NFVO. This approach requires additional logic in the NFVO resource allocation algorithms to jointly perform the optical path computation. Operationally, the

SDN controller setups optical paths, seamlessly re-configuring the ARoF transceivers. The communication between NFVO and SDN controller is based on the transport API (TAPI) specification, with extensions to deal with the specific characteristics of SDM/WDM technologies. As for the PNFs, the configuration of the ARoF elements is performed through the ARoF agent.

B. Configuration and monitoring parameters

A BBU agent attaches an ARoF BBU, which meets and extends 5G NR transmission bandwidth configurations for FR2 [2], to the SDN control plane that indicates the proper configuration, in terms of modulation scheme (QPSK, 16-QAM, 64-QAM, 256-QAM), 5G NR numerology (2, 3, 4), and number of subcarriers (up to 3168 in steps of 4). Such a configuration is a solution to an optimization problem that considers input parameters such as the available RF bandwidth, required bitrate and quality of service. Moreover, the ARoF BBU can change the IF and thus choose a different RF, according to the instructions of the NFVO. Additionally, the ARoF BBU can provide EVM measurements on the receiving data (uplink direction) to the NFVO that can be used for extraction of mobile user distance information. An RRH agent is instantiated per RRH and in this scenario is mainly responsible for powering up the RF electronics and setting the gain of the power amplifiers that drive the antenna elements, as instructed by the NFVO. Finally, the ARoF agent is responsible for passing the proper configuration to the ARoF transceivers, which are used to convert the modulated IF signals from the electrical to the optical domain. In this scenario, the only control parameter supported is turning on and off the laser devices employed in the ARoF transceivers.

C. Service definition and workflow

In the ARoF scenario, the blueSPACE system is used to instantiate services where the mobile User Equipment (UE) interconnect to application components, deployed in the CO, through ARoF paths established across the blueSPACE fronthaul network. The workflow for the instantiation of the service is depicted in Fig.2. First, the network administrator (represented in the picture as the user) creates the NS Descriptor (NSD) and the VNF packages describing the VNFs and the NS to be instantiated, including descriptors for RRH and BBU PNFs. Such VNF Packages and NSD are then onboarded into the NFVO service catalogue. The actual deployment procedure starts with the NS instantiation request. The NFVO generates and returns an ID to uniquely identify the NS instance. The NFVO runs its placement algorithm to compute (a) the allocation of VMs in the CO, (b) which PNFs to use for this service and their required configuration and (c) the endpoints and the characteristics of the optical ARoF path to establish. If a suitable placement solution is found, the NFVO proceeds with the resource allocation process, interacting with the Edge Controller to create and interconnect the required virtual networks and VMs. The following step involves the configuration of all the service elements, i.e. the VNFs and the PNFs, which are configured through VNFM and PNFM respectively. In this phase, for example, BBU and RRH are configured with the settings selected by the placement algorithm. In the final step, the NFVO requests the SDN controller to setup a path between the BBU and RRH. Then, the SDN controller configures the involved ARoF transceivers by enabling/disabling the laser. The service is then instantiated.

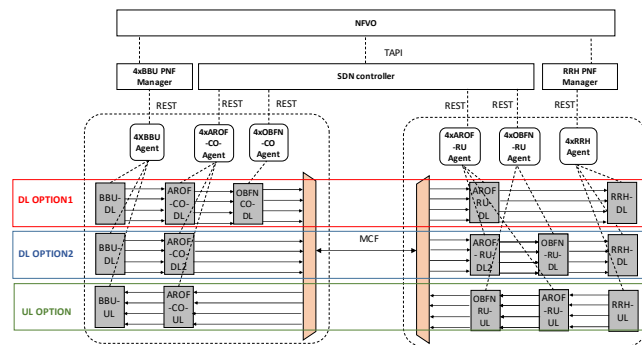

Fig.3: SDN/NFV OBFN fronthaul scenario

III. OBFN FRONTHAUL SCENARIO

A. Integrated test scenario

Beamforming has been identified as a key technology to overcome the increased path loss at mm-wave and to increase the possible rate of frequency reuse by focusing the emitted energy in a confined area. However, electrical beamformers face challenges with regards to energy consumption, footprint and heat dissipation, causing multi-beam transmission with continuous steering of the beam to be highly difficult task [3]. Optical beamforming, on the other hand, allows the compact integration of entire beamforming networks, due to the large wavelength difference between optical and RF signals [3].

The OBFN fronthaul scenario (Fig.3) including an OBFN, is based on the same ARoF with IFoF transmission concept discussed in section II. It is extended by augmenting the RRH with an antenna array for signal radiation and by including the OBFN in the signal transmission path in such a way, that from each of the OBFN inputs the signal gets copied to each OBFN output with progressive differential phase shifts which – after heterodyne upconversion at the RRH – result in an angular deflection of the maximum emission intensity from the antenna array, i.e., result in the beam being steered. By designing the OBFN to allow multiple inputs and hence have at each output an overlay of all input signals with different progressive differential delays, the OBFN allows simultaneous and independent transmission of multiple beams. Two options for placement of the downlink OBFN arise, resulting in different challenges for the fronthaul network. In the first option, the OBFN is placed at the CO, allowing centralization of the beamforming functionality, but imposing major challenges on the network as the signals from to OBFN must remain temporally aligned towards the antenna array. By placing the OBFN at the RU, this challenge is avoided, at the cost of lesser centralization as shown in option two. Finally, two variants of the OBFN exist [4], a coherent variant based on phase shifts and heterodyning of the optical signals, as employed in the two downlink cases, and an incoherent variant based on true time delays, which is employed for uplink in the presented scenario.

At the control level this scenario includes a new element that is the OBFN agent controlled by the SDN controller. It is located both at the CO and RU and is responsible for configuring any of the two variants of the OBFN, both for the downlink and uplink. The NBI of the OBFN agent is based on a REST API. The OBFN requires the provisioning of a spectral channel, composed of multiple optical channels in parallel.

B. Configuration and monitoring parameters

The OBFN agents enable the NFVO to control the beam-steering functionality offered by the OBFN-enabled blueSPACE fronthaul solution. For each beam, information regarding horizontal and vertical offset angles is passed to the OBFN agent, which is in turn translated to a set of parameters π_j , ϕ_j , with j ranging from 1 to the number of antenna elements, so that π_j parameters correspond to the relative power fed to antenna element j , while the ϕ_j parameters correspond to the respective relative phase. The π_j parameters are related to beam broadening and coverage optimization, while the ϕ_j parameters are related to beam focus and direction properties. These sets of parameters are then used to control several tuning elements (108 for a 4x4 OBFN configuration and over 200 for a 4x16 configuration) to introduce phase differences in the respective OBFN optical outputs that lead to the desired beam-steering functionality.

C. Service definition and workflow

The instantiation of the NFV network service is performed in the same way as for the ARoF scenario. The difference is request from the NFVO to the SDN controller to setup a path. In this case, the NFVO requests to setup a OBFN optical path between a pair of SIPs using the TAPI. Additionally, the NFVO specifies the reference wavelength, and an array with the offset angles (X and Y) for each beam. After the reception of the path request, the SDN controller maps the SIPs to the specific ARoF and OBFN devices and starts the configuration through the respective agents. For the ARoF, the SDN controller requests to the agent using the REST API (POST) to enable the lasers of the four involved ARoF transceivers, both at the CO and RU (for bidirectional connections). Then, the SDN controller requests to the agents located in the CO and RU, the configuration of the OBFN devices for the uplink and downlink. Uplink OBFN is always placed in the RU, and the downlink OBFN can be located either in the CO or in the RU, depending on the chosen option. Once the ARoF transceivers and the uplink/downlink OBFN are configured, the SDN sends a TAPI response to the NFVO.

IV. PoF FRONTHAUL SCENARIO

A. Integrated test scenario

Telecommunications operators are currently exploring different kinds of heterogeneous network paradigms to obtain maximum throughput from cellular networks at a minimum cost and energy per bit. Heterogeneous cellular networks include both traditional macro base stations (MBS) overlaid with smaller base stations featuring low power consumption (*femtocells*). Additionally, due to the mobility of users, base stations normally alternate between busy and idle periods. This can be exploited to share powering resources among small cells by means of centralized SDN-based power management. Thus, the target service of this scenario is that of smart remote powering in such a way that any CO laser can be used to feed a given RRH at any time [6] or when a user arrives at a small cell.

The scenario in Fig.4 shows a PoF system integrated in the radio-over-fiber architecture of BlueSPACE. From left to right, the Central Office hosts the BBU, the ARoF module and the PoF system. The PoF system includes a pool of High-Power Laser Diodes (HPLD) followed by an optical switch that allows to select the core(s) of the MCF to be employed to transmit power

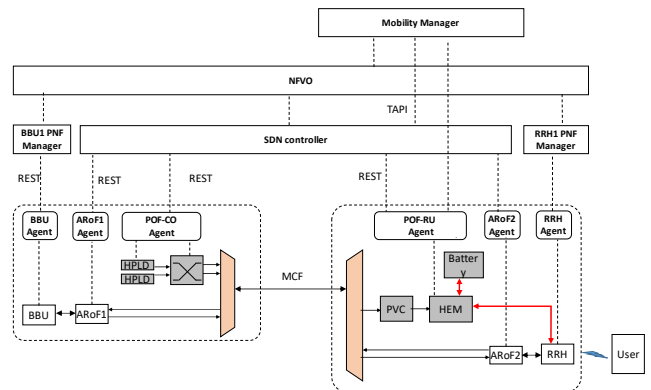

Fig.4: SDN/NFV PoF fronthaul scenario

and the ARoF. This PoF system is controlled by the PoF-CO Agent that deals with the SDN controller. At the RU, the PoF subsystem includes the FIFO, the Photo-Voltaic Converters (PVC), a battery and dedicated electronics –the Hardware Energy Manager (HEM)– to optimize PVC operation, manage the received energy (powering the load or the battery for future use, adapting to the required voltage level ...) depending on the control signals.

From the network service perspective, the scenario is similar to the ARoF one, but the entire service instantiation procedure is activated by an additional component, called Mobility Manager, which operates on top of the NFVO implementing upper layer logic (e.g. at the service level). In particular, the Mobility Manager takes decisions about activation and deactivation of femtocells based on the users' location, coordinating this with the service instantiation procedures.

B. Configuration and monitoring parameters

In order to support centralised smart control of remote power, the PoF system is open to the SDN controller to control the following parameters at the CO and RUs respectively. At the CO Side, we find the following parameters: (1) Power Laser List where a *ChannelID*, *Transmission Window*, *Transmission Power* and *Fiber Core ID* can be configured. At the RU Side, the following parameters are available: (1) Channel List: containing two parameters, *Channel ID* and *Channel Type* (Data|Power); (2) Power Switch: where *State* (ChargingBattery|DirectFeed|Both) and *Output Voltage* can be configured; (3) a Load List containing a *Load ID*, its *State* (ON|OFF) and the *Current Drain*; and (4) Sensor Data that enables the SDN controller to monitor the *Received Power*, *Battery Level* and *Ambient Temperature*.

C. Service definition and workflow

Supplying PoF to the remote site requires a “power channel”, which can be considered as an optical path with specific characteristics. This channel is established at the beginning of the entire process, requested by the Mobility Manager directly to the SDN controller, and it is kept active constantly independently on the specific services established over the infrastructure. Then, when a mobile user is detected close to a femtocell, the Mobility Manager establishes a connectivity service for that cell. First of all, it requests the SDN controller to turn on the cell via the PoF

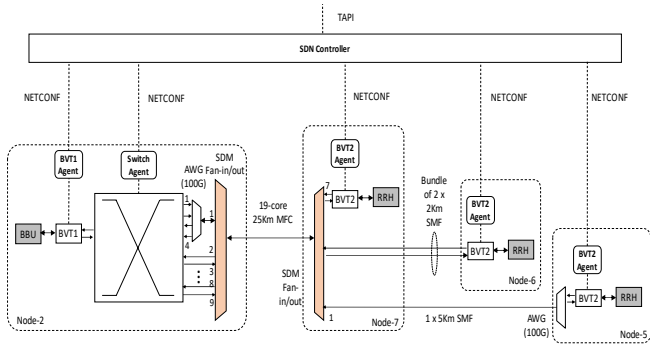

Fig.5 SDN/NFV DRoF fronthaul scenario.

agents. Then, it requests a connectivity service to the NFVO, starting the same workflow as described in the ARoF scenario. After the service is established, the Mobility Manager starts collecting monitoring information from the remote site through the SDN controller and the PoF Agent, in order to know when the user leaves the cell, or the battery level gets too low. When that happens, the Mobility Manager terminates the service and turns off the cell, allowing it to recharge the depleted battery

V. DRoF FRONTHAUL SCENARIO

A. Integrated test scenario

Even ARoF is the main solution of blueSPACE, DRoF in a hybrid WDM/SDM scenario is also covered. The corresponding test scenario is shown in Fig.5. It is composed by a CO that serves a remote node (RN) and different cell sites. The remote node is intended as a main space division demultiplexing point and eventually serving a macro-cell. The cell sites are proposed for a small cell service, using standard SMF or a bundle of them.

At the CO a BBU (and eventually a pool of them) is attached to the corresponding bandwidth/variable transceiver (BVT). This BVT is based on OFDM with 512 subcarriers spaced by 39 MHz featuring adaptive modulation [7]. The inputs/outputs of the BVT are connected to an optical switch in order to perform the appropriate connections to either the fan-in/out for SDM or to an arrayed waveguide grating (for wavelength multiplexing and/or demultiplexing). Therefore, by controlling the switch and the BVT we can establish connections featuring either pure SDM or also include WDM. The CO delivers its data signals to an optical distribution network, whose feeder stage is a 25 km multi-core fiber (MCF) that connects the CO with the RN. At the remote node signals are space demultiplexed by means of a fan-in/out device. After the remote node, different drop stages are envisioned, either featuring 1-core SMF bundles for continuing SDM paradigm or just an SMF with WDM. Finally, the cell sites also contain BVTs and eventual wavelength demultiplexing stages.

The blocks expected to interact with the SDN controller are the optical switch of the CO and the different BVTs. Each of them has an SDN agent that interacts with the SDN controller by means of the NETCONF protocol.

B. Configuration and monitoring parameters

The switch is an off-the-shelf optical switching matrix supporting cross-connection between any pair of input and output ports. The most interesting optical element to control is the BVT,

since they can be configured for an optimal management of the network resources [7]. The parameters able to be configured at the BVT are: status (active, off, standby), nominal central frequency, FEC (hard-decision or soft-decision), equalization (zero-forcing or minimum mean square error), and constellation. Constellation is set in a per subcarrier basis by means of two vectors: one containing the bits per symbol (i.e. for setting the actual constellation: BPSK, 4-QAM up to 256-QAM), and another one with the normalized power per symbol for each subcarrier. Therefore, the capacity can be set by the SDN controller by generating the suitable constellation. Also, the BVT has a couple of monitored parameters; the overall BER, giving a general view of the connection performance, and the SNR per subcarrier, in order to have an idea of the channel profile to enable adaptive modulation of the OFDM subcarriers.

C. Service definition and workflow

The service that is provided in this scenario is a connectivity service involving a pair of BVTs and an optical channel connecting them. It is provided by the SDN controller using the TAPI. The TAPI connectivity service request specifies the end-points, the requested capacity, and the required FEC. First, the SDN controller computes the constellation, equalization, nominal central frequency and the input/output ports required to configure the BVTs and the optical switch. Then, the SDN controller requests the configuration of the optical switch for the computed input/output ports using a REST API. After that, the SDN controller request the configuration of the BVTs (both at the CO and RU) and configures the BVTs in estimation mode. A Yang model for the BVTs has been defined [5], and the protocol between the SDN controller and the agents is NETCONF. The parameters to be configured are the constellation, equalization, nominal central frequency and FEC. Once both BVTs are configured, the SDN controller requests the SNR per subcarrier at reception to the BVT agents. This information is used by the SDN controller to compute again the most optimal constellation and equalization for adaptive modulation. Finally, the SDN controller configure again the BVTs in transmission mode with the new constellation and equalization.

VI. CONCLUSIONS

The introduction of SDM combined with ARoF, DRoF, OBFN and PoF, together with SDN/NFV control systems is key for the development of fronthaul networks for 5G and beyond.

REFERENCES

- [1] S. Rommel et al., "High-capacity 5G fronthaul networks based on optical space division multiplexing," *IEEE Trans. Broadcast.*, 2019.
- [2] 3GPP TS 38.104, "NR: Base Station (BS) radio transmission and reception," no. Rel. 15. 3GPP, Valbonne, France, Mar-2018.
- [3] C. Tsokos et al., "Analysis of a multibeam optical beamforming network based on Blass matrix architecture," *J. Lightw. Technol.*, vol 36, no. 16, pp. 3354-3372, 2018.
- [4] C. Roeloffzen et al., "Enhanced coverage through optical beamforming in fibre wireless networks," in *Proc. ICTON 2017*, p. Th.A2.1.
- [5] R. Muñoz et al., "SDN-enabled Sliceable Multi-dimensional (Spectral and Spatial) Transceiver Controlled with YANG/NETCONF," *OFC 2018*.
- [6] G. Otero, et al. "SDN-based Multi-Core Power-over-Fiber (PoF) System for 5G Fronthaul: Towards PoF Pooling", in *ECOC'18*, Italy, Sept 2018.
- [7] J. M. Fabrega et al., "Hybrid WDM/SDM mobile fronthaul traffic delivery using SDN-enabled sliceable bandwidth/variable transceivers," in *Proc. IEEE Intl. Symposium BMSB*. Jun. 2018